



Technical Data Sheet

RF/Microwave Signal Generators

MG3690C

RF/Microwave Signal Generator, 0.1 Hz to 70 GHz/325 GHz

Introduction

The MG3690C is the “ideal microwave signal generator” because it offers unsurpassed frequency coverage, the lowest phase noise, leveled output power, spectral purity, switching speed, modulation performance, size, upgradeability, reliability, and service. Our signal generators are configurable for a broad range of applications from R&D to manufacturing and depot repair. Anritsu provides you a total solution including proven reliability and standard 3 year warranty plus pre- and post-sale support that is the best in the industry.



The Ideal Signal Generator

Specifications

The specifications in the following pages describe the warranted performance of the generator for $25 \pm 10^\circ\text{C}$. Typical specifications describe expected, but not warranted, performance based on sample testing.

Frequency Coverage

Model/Option No.	Frequency Coverage	Output Type
MG3691C	2 GHz to 10 GHz	K(f)
MG3692C	2 GHz to 20 GHz	K(f)
MG3693C	2 GHz to 31.8 GHz	K(f)
MG3694C	2 GHz to 40 GHz	K(f)
MG3695C	2 GHz to 50 GHz	V(f)
MG3697C	2 GHz to 67 GHz*	V(f)
Option 4	8 MHz to 2.2 GHz**	Model No. Dependent
Option 5	8 MHz to 2 GHz**	Model No. Dependent
Option 22	0.1 Hz to 10 MHz	Model No. Dependent

* Operational to 70 GHz

** All specifications apply ≥ 10 MHz

Options 4 and 5: Frequency extension down to 8 MHz

Two options are available to extend the 2 GHz low end frequency limit of the base models down to 8 MHz. Option 4 uses a digital down-converter (DDC) with successive divide-by-two circuitry. It offers the best phase noise performance of the two choices, at the expense of some analog performance < 500 MHz. In that range, analog sweep mode is not available, and pulse modulation performance is specified as typical. In addition, frequency and phase modulation mod index is scaled by the division ratio of each band of the DDC. Option 5 maintains all analog performance by using a heterodyne mixing down-converter, but does not improve phase noise performance.

Option 22: Frequency extension down to DC

If frequency coverage down to 0.1 Hz is desired, Option 22 can be added with either Option 4 or 5. Option 22 uses Direct Digital Synthesis (DDS) for CW and Step Sweep modes of operation. Modulation and analog sweep are not available in the DDS band. Frequency resolution < 10 MHz is 0.02 Hz. Output power across the complete instrument frequency range is degraded by 2 dB.

CW Mode

Output: Twenty independent, presettable CW frequencies (F0 – F9 and M0 – M9).

Accuracy: Same as internal or external 10 MHz time base.

Internal Time Base Stability:

With Aging: $< 2 \times 10^{-9}/\text{day}$ ($< 5 \times 10^{-10}/\text{day}$ with Option 16)

With Temperature: $< 2 \times 10^{-9}/\text{deg C}$ over 0°C to 55°C ($< 2 \times 10^{-10}/\text{deg C}$ with Option 16)

Resolution: 0.01 Hz

Internal Time Base Calibration: The internal time base can be calibrated via the System Cal menu to match an external reference (10 MHz \pm 50 Hz).

External 10 MHz Reference Input: Accepts external 10 MHz \pm 50 Hz (typical), 0 to +20 dBm time base signal. Automatically disconnects the internal high-stability time-base option, if installed. BNC, rear panel, 50 Ω impedance. Selectable Bandwidth for best phase noise immunity or best phase tracking performance.

10 MHz Reference Output: 1 Vp-p into 50 Ω , AC coupled. Rear panel BNC; 50 Ω impedance.

Phase Offset: Adjustable in 0.1 degree steps.

Electronic Frequency Control (EFC) Input: -4V to $+4\text{V}$ input range; 8×10^{-8} Fout Hz/V sensitivity (typical); ≤ 250 Hz Modulation BW; Rear panel BNC; High Impedance

Phase-Locked Step Sweep Mode

Sweep Width: Independently selected, 0.01 Hz to full range. Every frequency step in sweep range is phase-locked.

Accuracy: Same as internal or external 10 MHz time base.

Resolution (Minimum Step Size): 0.01 Hz

Linear/Log Sweep: User-selectable linear or log sweep.

In log sweep, step size logarithmically increases with frequency.

Steps: User-selectable number of steps or the step size.

Number of Steps: Variable from 1 to 10,000

Step Size: 0.01 Hz to the full frequency range of the instrument. (If the step size does not divide into the selected frequency range, the last step is truncated)

Dwell Time Per Step: Variable from 1 ms to 99 seconds

Fixed Rate Sweep: Allows the user to set the total time of the sweep, including lock time. Variable from 20 ms to 99 seconds.

Analog Sweep Mode (Option 6)

Sweep Width: Independently selected from 1 MHz to full frequency range. With Option 4, Digital Down Converter, Analog sweep is only available ≥ 500 MHz. Analog sweep is not available < 10 MHz with Option 22.

Accuracy: The lesser of ± 30 MHz or (± 2 MHz + 0.25% of sweep width) for Sweep Speeds of ≤ 50 MHz/ms (typical)

Sweep Time Range: 30 ms to 99 seconds

Alternate Sweep Mode

Sweeps alternately in step sweep between any two sweep ranges. Each sweep range may be associated with a power level.

Manual Sweep Mode

Provides stepped, phase-locked adjustment of frequency between sweep limits. User-selectable number of steps or step size.

List Sweep Mode

Under GPIB control or via the front panel, up to 4 tables with 2000 non-sequential frequency/power sets can be stored and then addressed as a phase-locked step sweep. One table of 2000 points is stored in non-volatile memory, all other tables are stored in volatile memory.

Programmable Frequency Agility

Under GPIB control, up to 3202 non-sequential frequency/power sets can be stored and then addressed as a phase-locked step sweep. Data stored in volatile memory.

Markers

Up to 20 independent, settable markers (F0 – F9 and M0 – M9).

Video Markers: +5V or -5V marker output, selectable from system menus. AUX I/O connector, rear panel.

Intensity Markers: Produces an intensity dot on analog display traces, obtained by a momentary dwell in RF sweep, in analog sweeps of < 1 s.

Marker Accuracy: Same as sweep frequency accuracy.

Marker Resolution:

Analog Sweep: 1 MHz or Sweep Width/4096 which ever is greater.

Step Sweep: 0.01 Hz.

Sweep Triggering

Sweep triggering is provided for Analog Frequency Sweep, Step Frequency Sweep, List Frequency Sweep, and CW Power Sweep.

Auto: Triggers sweep automatically.

External: Triggers a sweep on the low to high transition of an external TTL signal. AUX I/O connector, rear panel.

Single: Triggers, aborts, and resets a single sweep. Reset sweep may be selected to be at the top or bottom of the sweep.

General

Stored Setups: Stores front panel settings and nine additional front-panel setups in a non-volatile RAM. A system menu allows saving and recalling of instrument setups. Whenever the instrument is turned on, control settings come on at the same functions and values existing when the instrument was turned off.

Memory Sequencing Input: Accepts a TTL low-level signal to sequence through ten stored setups. AUX I/O connector, rear panel.

Self-Test: Instrument self-test is performed when Self-Test soft-key is selected. If an error is detected, an error message is displayed in a window on the LCD identifying the probable cause and remedy.

Secure Mode: Disables all frequency and power level state displays. Stored setups saved in secure mode remain secured when recalled. Mode selectable from a system menu and via GPIB.

Parameter Entry: Instrument-controlled parameters can be entered in three ways: keypad, rotary data knob, or the \wedge and \vee touch pads of the cursor-control key. The keypad is used to enter new parameter values; the rotary data knob and the cursor-control key are used to edit existing parameter values. The \wedge and \vee touch pads of the cursor-control key move the cursor left and right one digit under the open parameter. The rotary data knob or the \wedge and \vee touch pads will increment or decrement the digit position over the cursor. Controlled parameters are frequency, power level, sweep time, dwell time, and number of steps. Keypad entries are terminated by pressing the appropriate soft key. Edits are terminated by exiting the edit menu.

Reset: Returns all instrument parameters to predefined default states or values. Any pending GPIB I/O is aborted. Selectable from the system menu.

Master/Slave Operation: Allows two output signals to be swept with a user-selected frequency offset. One instrument controls the other via AUX I/O and SERIAL I/O connections. Requires a Master/Slave Interface Cable Set (Part No. ND36329).

User Level Flatness Correction: Allows user to calibrate out path loss due to external switching and cables via entered power table from a GPIB power meter or calculated data. When user level correction is activated, entered power levels are delivered at the point where calibration was performed. Supported power meters are Anritsu ML2437A, ML2438A, ML2480A/B, ML2490A, and ML4803A and HP 437B, 438A, and 70100A. Five user tables are available with up to 801 points/table.

Warm Up Time:

From Standby: 30 minutes.

From Cold Start (0 deg C): 120 hours to achieve specified frequency stability with aging. Instruments disconnected from AC line power for more than 72 hours require 30 days to return to specified frequency stability with aging.

Power: 85 Vac - 264 Vac, 48 Hz - 440 Hz, 250 VA maximum

Standby: With ac line power connected, unit is placed in standby when front panel power switch is released from the OPERATE position.

Weight: 18 kg maximum

Dimensions: 133 H x 429 W x 450 D mm

Warranty: 3 years from ship date

Remote Operation

All instrument functions, settings, and operating modes (except for power on/standby) are controllable using commands sent from an external computer via the GPIB (IEEE-488 interface bus).

GPIB Commands: Native, SCPI

GPIB Address: Selectable from a system menu

IEEE-488 Interface Function Subset:

Source Handshake: SH1

Acceptor Handshake: AH1

Talker: T6

Listener: L4

Service Request: SR1

Remote/Local: RL1

Parallel Poll: PP1

Device Clear: DC1

Device Trigger: DT1

Controller Capability: C0, C1, C2, C3, C28

Tri-State Driver: E2

GPIB Status Annunciators: When the instrument is operating in Remote, the GPIB status annunciators (listed below) will appear in a window on the front panel LCD.

Remote: Operating on the GPIB (all instrument front panel keys except for the SYSTEM key and the RETURN TO LOCAL soft-key will be ignored).

LLO (Local Lockout): Disables the RETURN TO LOCAL soft-key. Instrument can be placed in local mode only via GPIB or by cycling line power.

Emulations: The instrument responds to the published GPIB commands and responses of the Anritsu Models 6600, 6700, and 6XX00-series signal sources. When emulating another signal source, the instrument will be limited to the capabilities, mnemonics, and parameter resolutions of the emulated instrument.

For users who wish to use Ethernet or USB control interfaces, the following adapters available from National Instruments are recommended:

Ethernet: NI GPIB-ENET/1 \emptyset \emptyset

USB: NI GPIB-USB-MS

Environmental (MIL-PRF-28800F, class 3)

Storage Temperature Range: -40 °C to +75 °C

Operating Temperature Range: 0 °C to +50 °C

Relative Humidity: 5% to 95% at 40 °C

Altitude: 4,600 meters, 43.9 cm Hg

EMI: Meets the emission and immunity requirements of

EN61326: 1998

EN55011: 1991/CISPR-11:1990 Group 1 Class A

EN61000-4-2: 1995 - 4 kV CD, 8 kV AD

EN61000-4-3: 1997 - 3 V/m

EN61000-4-4: 1995 - 0.5 kV SL, 1 kV PL

EN61000-4-5: 1995 - 1 kV - 2 kV L-E

EN61000-4-6: 1996

EN61000-4-11: 1994

Vibration: Random, 5 Hz to 500 Hz, 0.015-0.0039g²/Hz PSD
Sinusoidal, 5 Hz to 55 Hz, 0.33 mm displacement

Safety Directive: EN 61010-1: 1993 + A1: 92 + A2: 95

Frequency Switching Time

Definitions

Free Running Mode: (Step or List Sweep)

t_{sw} = Switching Time, Unlocked

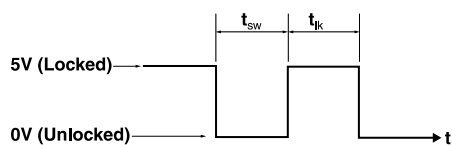

Lock Status Indicator
Rear Panel Aux I/O Connector (Pin 11)
(The lock status indicator goes high, when the output is within 1 kHz of the final frequency.)

$t_{lk} = \text{Locked Time} = 1\text{ms} + t_{dw}$

t_{dw} = Dwell Time, after locking. Selectable, 1 ms minimum

$t_{lk}(\text{min}) = 2\text{ms}$

Single Frequency Trigger Mode: (List, non-sequential, and CFx modes)

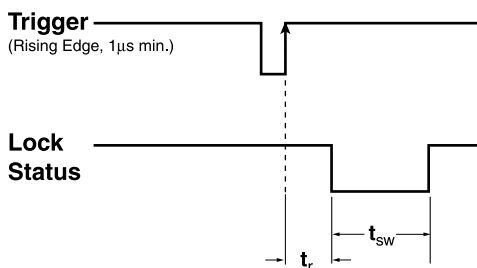

$t_r = \text{Trigger Response Time} = 2\text{ms}$
(applies to both GPIB and External TTL triggers)

Switching Time (t_{sw})

t_{sw}^* (ms)	Condition
5 ms + 1 ms/GHz	step not starting at, or crossing dwell frequencies
7 ms + 1 ms/GHz (typical)	step not starting at, or crossing band switching frequencies
8 ms + 1 ms/GHz (typical)	step starting at, or crossing band switching frequencies

Band Switching Dwell Frequencies: 2 (2.2 w/Opt. 4), 10, 20, 40 GHz

Filter Switching Dwell Frequencies: 3.3, 5.5, 8.4, 13.25, 25, 32 GHz

< 2.2 GHz w/Opt. 4: 12.5, 15.625, 22.5, 31.25, 43.75, 62.5, 87.5, 125, 175, 250, 350, 500, 700, 1050, 1500 MHz

*Not applicable with FM mode active

Spectral Purity

All specifications apply at the lesser of +10 dBm output or maximum specified leveled output power, unless otherwise noted.

Spurious Signals

Harmonic and Harmonically-related:

Frequency Range	Standard
0.1 Hz to 10 MHz (Option 22)	< -30 dBc
10 MHz to \leq 100 MHz (Option 4)	< -40 dBc
> 100 MHz to \leq 2.2 GHz (Option 4)	< -50 dBc
10 MHz to \leq 50 MHz (Option 5)	< -30 dBc
> 50 MHz to < 2 GHz (Option 5)	< -40 dBc
2 GHz (> 2.2 GHz w/Option 4) to \leq 20 GHz	< -60 dBc*
> 20 GHz to \leq 40 GHz	< -40 dBc**
> 40 GHz to \leq 50 GHz (MG3695C)	< -40 dBc*
> 40 GHz to \leq 67 GHz (MG3697C)	< -25 dBc

* -30 dBc typical with high power Option 15

** 20 GHz to 21 GHz and 39 GHz to 40 GHz, -20 dBc typical (Option 15 only)

Non-harmonics:

Frequency Range	Standard
0.1 Hz to 10 MHz (Option 22)	< -30 dBc
10 MHz to \leq 2.2 GHz (Option 4)	< -60 dBc
10 MHz to \leq 2 GHz (Option 5)	< -40 dBc
> 2 GHz (2.2 GHz w/Option 4) to \leq 67 GHz	< -60 dBc

Power Line and Fan Rotation Spurious Emissions (dBc):

Frequency	300 Hz	Offset from Carrier	
		300 Hz to 1 kHz	> 1 kHz
10 MHz to \leq 500 MHz (Option 4)	< -68	< -72	< -72
> 500 MHz to \leq 1050 MHz (Option 4)	< -62	< -72	< -72
> 1050 MHz to \leq 2200 MHz (Option 4)	< -56	< -66	< -66
0.01 GHz to \leq 8.4 GHz	< -50	< -60	< -60
> 8.4 GHz to \leq 20 GHz	< -46	< -56	< -60
> 20 GHz to \leq 40 GHz	< -40	< -50	< -54
> 40 GHz to \leq 67 GHz	< -34	< -44	< -48

Residual FM* (CW and Step Sweep modes, 50 Hz - 15 kHz BW) (typical):

Frequency Range	Residual FM (Hz RMS)	
	Option 3/3X	Standard
\leq 8.4 GHz	< 40	< 120
> 8.4 GHz to 20 GHz	< 40	< 220
> 20 GHz to \leq 40 GHz	< 80	< 440
> 40 GHz to \leq 67 GHz	< 160	< 880

Residual FM* (Analog Sweep and Unlocked FM modes, 50 Hz - 15 kHz BW) (typical):

Frequency Range	Residual FM (kHz RMS)	
	Unlocked Narrow FM mode	Unlocked Wide FM mode or Analog Sweep (typ.)
0.01 GHz to \leq 20 GHz	< 10	< 25
> 20 GHz to \leq 40 GHz	< 20	< 50
> 40 GHz to \leq 67 GHz	< 40	< 100

*Residual FM is not applicable with FM locked mode

AM Noise Floor:

Typically < -145 dBm/Hz at 0 dBm output and offsets > 5 MHz from carrier.

Single-Sideband Phase Noise*

Single-Sideband Phase Noise (dBc/Hz): (Typical)

Frequency Range	Offset from Carrier					
	10 Hz	100 Hz	1 kHz	10 kHz	100 kHz	1 MHz
0.1 Hz to <10 MHz (Option 22)	-80 (-100)	-90 (-110)	-120 (-125)	-130 (-139)	-130 (-141)	-130 (-141)
10 MHz to 15.625 MHz (Option 4)	-102 (-113)	-128 (-133)	-142 (-149)	-145 (-152)	-145 (-153)	-145 (-153)
> 15.625 MHz to 31.25 MHz (Option 4)	-97 (-109)	-125 (-130)	-142 (-147)	-144 (-149)	-144 (-153)	-145 (-155)
> 31.25 MHz to 62.5 MHz (Option 4)	-92 (-104)	-122 (-128)	-140 (-146)	-142 (-146)	-143 (-150)	-145 (-155)
> 62.5 MHz to 125 MHz (Option 4)	-87 (-98)	-114 (-118)	-133 (-139)	-130 (-140)	-130 (-143)	-145 (-155)
> 125 MHz to 250 MHz (Option 4)	-82 (-93)	-108 (-113)	-126 (-134)	-124 (-134)	-124 (-138)	-145 (-153)
> 250 MHz to 500 MHz (Option 4)	-75 (-87)	-102 (-109)	-120 (-128)	-118 (-127)	-118 (-130)	-143 (-149)
> 500 MHz to 1050 MHz (Option 4)	-70 (-80)	-94 (-100)	-115 (-123)	-115 (-122)	-116 (-126)	-138 (-144)
> 1050 MHz to 2200 MHz (Option 4)	-65 (-74)	-86 (-96)	-113 (-117)	-111 (-116)	-114 (-120)	-133 (-139)
10 MHz to < 2000 MHz (Option 5)	-62 (-72)	-85 (-95)	-100 (-104)	-102 (-106)	-102 (-106)	-111 (-114)
2 GHz to 6 GHz	-54 (-64)	-81 (-88)	-102 (-109)	-103 (-110)	-106 (-114)	-128 (-133)
> 6 GHz to 10 GHz	-52 (-62)	-75 (-85)	-98 (-106)	-104 (-109)	-106 (-113)	-126 (-132)
> 10 GHz to 20 GHz	-45 (-55)	-69 (-78)	-92 (-101)	-98 (-103)	-98 (-106)	-124 (-131)
> 20 GHz to 40 GHz	-38 (-48)	-62 (-72)	-86 (-94)	-92 (-100)	-92 (-100)	-118 (-124)
> 40 GHz to 67 GHz	-32 (-42)	-56 (-66)	-80 (-88)	-87 (-94)	-82 (-91)	-112 (-118)

Single-Sideband Phase Noise (dBc/Hz) - Option 3: (Typical)

Frequency Range	Offset from Carrier					
	10 Hz	100 Hz	1 kHz**	10 kHz**	100 kHz	1 MHz
0.1 Hz to < 10 MHz (Option 22)	-80 (-100)	-90 (-110)	-120 (-125)	-130 (-139)	-130 (-141)	-130 (-141)
10 MHz to 15.625 MHz (Option 4)	-102 (-120)	-128 (-140)	-142 (-150)	-145 (-152)	-148 (-153)	-148 (-152)
> 15.625 MHz to 31.25 MHz (Option 4)	-97 (-108)	-125 (-128)	-142 (-149)	-145 (-153)	-148 (-153)	-148 (-155)
> 31.25 MHz to 62.5 MHz (Option 4)	-92 (-109)	-122 (-131)	-140 (-146)	-145 (-153)	-148 (-153)	-148 (-156)
> 62.5 MHz to 125 MHz (Option 4)	-87 (-98)	-114 (-118)	-134 (-139)	-142 (-147)	-143 (-148)	-148 (-155)
> 125 MHz to 250 MHz (Option 4)	-82 (-93)	-108 (-113)	-129 (-134)	-138 (-143)	-137 (-142)	-148 (-153)
> 250 MHz to 500 MHz (Option 4)	-77 (-91)	-102 (-114)	-124 (-130)	-132 (-137)	-128 (-137)	-144 (-153)
> 500 MHz to 1050 MHz (Option 4)	-72 (-83)	-98 (-103)	-119 (-123)	-126 (-132)	-122 (-132)	-139 (-150)
> 1050 MHz to 2200 MHz (Option 4)	-66 (-77)	-92 (-101)	-113 (-119)	-121 (-126)	-117 (-125)	-135 (-146)
10 MHz to < 2000 MHz (Option 5)	-64 (-72)	-85 (-95)	-100 (-104)	-102 (-106)	-102 (-106)	-111 (-114)
2 GHz to 6 GHz	-54 (-77)	-82 (-93)	-106 (-111)	-115 (-119)	-112 (-119)	-138 (-142)
> 6 GHz to 10 GHz	-52 (-73)	-75 (-88)	-102 (-109)	-113 (-119)	-115 (-120)	-134 (-140)
> 10 GHz to 20 GHz	-52 (-66)	-69 (-82)	-100 (-105)	-109 (-115)	-109 (-115)	-130 (-137)
> 20 GHz to 40 GHz	-45 (-59)	-63 (-75)	-94 (-98)	-104 (-108)	-103 (-109)	-122 (-131)
> 40 GHz to 67 GHz	-40 (-51)	-58 (-68)	-89 (-91)	-97 (-103)	-97 (-103)	-118 (-125)

Single-Sideband Phase Noise (dBc/Hz) - Option 3X: (Typical)

Frequency Range	Offset from Carrier						
	1 Hz	10 Hz	100 Hz	1 kHz**	10 kHz**	100 kHz	1 MHz
0.1 Hz to < 10 MHz (Option 22)	-60 (-70)	-80 (-100)	-90 (-110)	-120 (-125)	-130 (-139)	-130 (-141)	-130 (-141)
10 MHz to 15.625 MHz (Option 4)	-94 (-103)	-118 (-128)	-136 (-141)	-142 (-150)	-145 (-152)	-148 (-153)	-148 (-152)
> 15.625 MHz to 31.25 MHz (Option 4)	-88 (-96)	-113 (-123)	-130 (-137)	-142 (-149)	-145 (-153)	-148 (-153)	-148 (-155)
> 31.25 MHz to 62.5 MHz (Option 4)	-83 (-90)	-109 (-118)	-125 (-133)	-140 (-146)	-145 (-153)	-148 (-153)	-148 (-156)
> 62.5 MHz to 125 MHz (Option 4)	-77 (-86)	-103 (-111)	-119 (-127)	-134 (-139)	-142 (-147)	-143 (-148)	-148 (-155)
> 125 MHz to 250 MHz (Option 4)	-71 (-81)	-97 (-104)	-113 (-121)	-129 (-134)	-138 (-143)	-137 (-142)	-148 (-153)
> 250 MHz to 500 MHz (Option 4)	-67 (-76)	-91 (-98)	-107 (-115)	-124 (-130)	-132 (-137)	-128 (-137)	-144 (-153)
> 500 MHz to 1050 MHz (Option 4)	-60 (-69)	-84 (-92)	-101 (-109)	-119 (-123)	-126 (-132)	-122 (-132)	-139 (-150)
> 1050 MHz to 2200 MHz (Option 4)	-53 (-62)	-77 (-87)	-95 (-103)	-113 (-119)	-121 (-126)	-117 (-125)	-135 (-146)
10 MHz to < 2000 MHz (Option 5)	-38 (-45)	-68 (-78)	-85 (-95)	-100 (-104)	-102 (-106)	-102 (-106)	-111 (-114)
2 GHz to 6 GHz	-46 (-52)	-70 (-77)	-86 (-94)	-106 (-111)	-115 (-119)	-112 (-119)	-138 (-142)
> 6 GHz to 10 GHz	-38 (-46)	-68 (-77)	-83 (-91)	-102 (-109)	-113 (-119)	-115 (-120)	-134 (-140)
> 10 GHz to 20 GHz	-35 (-42)	-64 (-72)	-80 (-85)	-100 (-105)	-109 (-115)	-109 (-115)	-130 (-137)
> 20 GHz to 40 GHz	-29 (-36)	-58 (-65)	-74 (-79)	-94 (-98)	-104 (-108)	-103 (-109)	-122 (-131)
> 40 GHz to 67 GHz	-23 (-30)	-53 (-59)	-69 (-73)	-89 (-91)	-97 (-103)	-97 (-103)	-118 (-125)

* Phase noise is specified and guaranteed only with internal reference. In External Reference mode, the phase noise of the external supplied reference, and the selected external reference band width, will dictate the instrument phase noise performance. Phase noise is not degraded when adding high power Option 15.

** When fitted with option 36 and when multiple units are connected for purposes of Ultra-Stable Phase Tracking, phase noise may be degraded by up to 4 dB at 1 kHz and 10 kHz offsets.

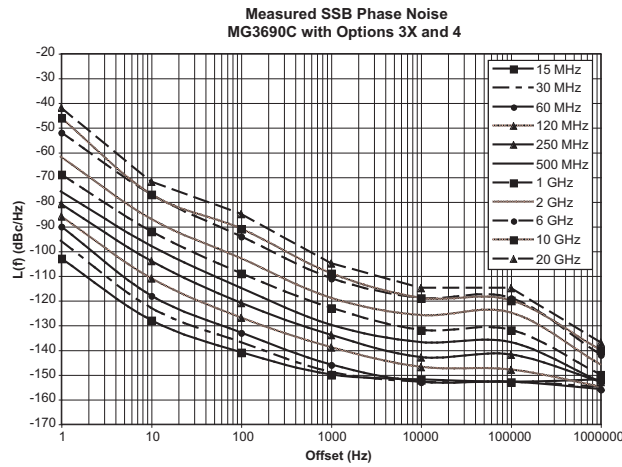
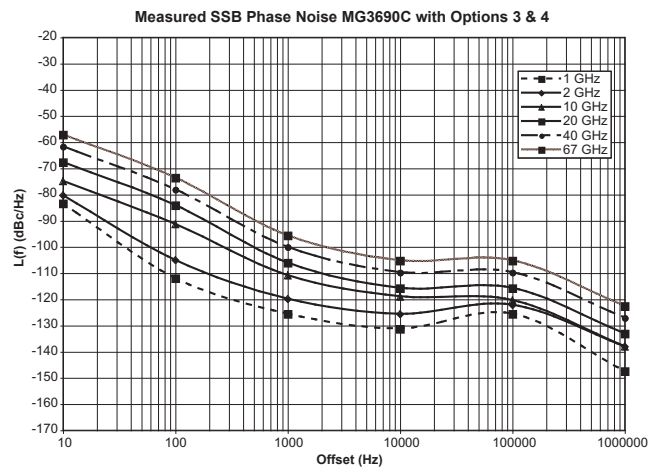
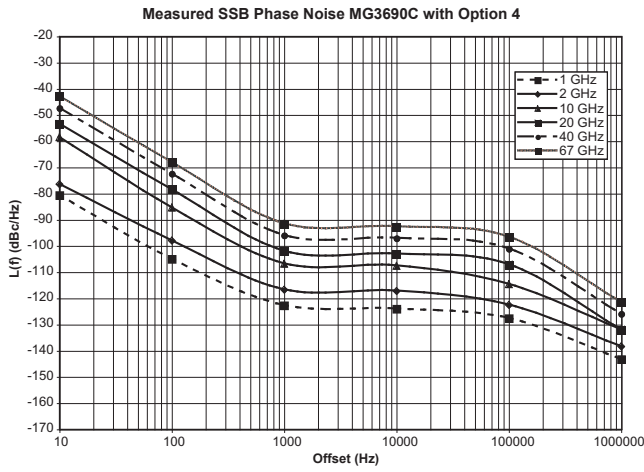

RF Output

Power level specifications apply at 25 ± 10 °C.

Maximum Levelled Output Power*:**

Model Number	Configuration	Frequency Range (GHz)	Output Power (dBm)	Output Power With Step Attenuator (dBm)	Output Power With Electronic Step Attenuator (dBm)
MG3691C	w/opt 4 or 5 STD	< 2 GHz*	+19.0	+18.0	+15.0
		≥ 2 GHz** to ≤ 10 GHz	+19.0	+18.0	+13.0
MG3692C	w/opt 4 or 5 STD STD	< 2 GHz*	+19.0	+18.0	Not Available
		≥ 2 GHz** to ≤ 10 GHz	+19.0	+18.0	
		> 10 GHz to ≤ 20 GHz	+17.0	+15.0	
MG3693C	w/opt 4 or 5 STD STD STD	< 2 GHz*	+15.0	+14.0	Not Available
		≥ 2 GHz** to ≤ 10 GHz	+15.0	+14.0	
		> 10 GHz to ≤ 20 GHz	+12.0	+10.0	
		> 20 GHz to ≤ 31.8 GHz	+9.0	+6.0	
MG3694C	w/opt 4 or 5 STD STD STD	< 2 GHz*	+15.0	+14.0	Not Available
		≥ 2 GHz** to ≤ 10 GHz	+15.0	+14.0	
		> 10 GHz to ≤ 20 GHz	+12.0	+10.0	
		> 20 GHz to ≤ 40 GHz	+9.0	+6.0	
MG3695C	w/opt 4 or 5 STD STD STD	< 2 GHz*	+12.0	+10.0	Not Available
		≥ 2 GHz** to ≤ 20 GHz	+10.0	+8.0	
		> 20 GHz to ≤ 40 GHz	+6.0	+3.0	
		> 40 GHz to ≤ 50 GHz	+3.0	+0.0	
MG3697C	w/opt 4 or 5 STD STD STD	< 2 GHz*	+12.0	+10.0	Not Available
		≥ 2 GHz** to ≤ 20 GHz	+10.0	+8.0	
		> 20 GHz to ≤ 40 GHz	+6.0	+3.0	
		> 40 GHz to ≤ 67 GHz	+3.0	+0.0****	

* ≤ 2.2 GHz with Option 4

** > 2.2 GHz with Option 4

*** For output power with Option 22, 0.1 Hz to 10 MHz coverage, derate all specifications by 2 dB

**** Typical 60 GHz to 67 GHz

Maximum Leveled Output Power With Option 15 (High Power) Installed*:**

Model Number	Configuration	Frequency Range (GHz)	Output Power (dBm)	Output Power With Step Attenuator (dBm)	Output Power With Electronic Step Attenuator (dBm)
MG3691C	w/opt 4 or 5	< 2 GHz* ≥ 2 GHz** to ≤ 10 GHz	+19.0 +25.0	+18.0 +24.0	+15.0 +16.0
	w/o opt 4 or 5	≥ 2 GHz to ≤ 10 GHz	+26.0	+25.0	+16.0
MG3692C	w/opt 4 or 5	< 2 GHz* 2 GHz to 10 GHz > 10 GHz to 16 GHz > 16 GHz to 20 GHz	+19 dBm +25 dBm +22 dBm +21 dBm	+18 dBm +24 dBm +20 dBm +19 dBm	Not Available
	w/o opt 4 or 5	2 GHz to 10 GHz > 10 GHz to 16 GHz > 16 GHz to 20 GHz	+26 dBm +25 dBm +23 dBm	+25 dBm +23 dBm +21 dBm	
MG3693C	w/opt 4 or 5	< 2 GHz* ≥ 2 GHz** to ≤ 20 GHz > 20 GHz to ≤ 31.8 GHz	+17.0 +21.0 +17.0	+16.0 +19.0 +15.0	Not Available
	w/o opt 4 or 5	≥ 2 GHz to ≤ 20 GHz > 20 GHz to ≤ 31.8 GHz	+23.0 +19.0	+21.0 +17.0	
MG3694C	w/opt 4 or 5	< 2 GHz* ≥ 2 GHz** to ≤ 20 GHz > 20 GHz to ≤ 40 GHz	+17.0 +21.0 +17.0	+16.0 +19.0 +15.0	Not Available
	w/o opt 4 or 5	≥ 2 GHz to ≤ 20 GHz > 20 GHz to ≤ 40 GHz	+23.0 +19.0	+21.0 +17.0	
MG3695C	w/opt 4 or 5	< 2 GHz* ≥ 2 GHz** to ≤ 20 GHz > 20 GHz to ≤ 40 GHz > 40 GHz to ≤ 50 GHz	+16 +21 +17 +11	+14 +19 +15 +8	Not Available
	w/o opt 4 or 5	≥ 2 GHz to ≤ 20 GHz > 20 GHz to ≤ 40 GHz > 40 GHz to ≤ 50 GHz	+23 +19 +13	+21 +17 +10	
MG3697C	w/opt 4 or 5	< 2 GHz* ≥ 2 GHz** to ≤ 20 GHz > 20 GHz to ≤ 40 GHz > 40 GHz to ≤ 67 GHz > 67 GHz to ≤ 70 GHz	+16 +19 +16 +9 +3*****	+15 +18 +14 +6**** 0*****	Not Available
	w/o opt 4 or 5	≥ 2 GHz to ≤ 20 GHz > 20 GHz to ≤ 40 GHz > 40 GHz to ≤ 67 GHz > 67 GHz to ≤ 70 GHz	+21 +19 +9 +3*****	+19 +16 +6**** 0*****	

* ≤ 2.2 GHz with Option 4

** > 2.2 GHz with Option 4

*** For output power with Option 22, 0.1 Hz to 10 MHz coverage, derate all specifications by 2 dB

**** Typical 60 GHz to 67 GHz

***** Typical

Minimum Settable Power

Without an Attenuator: -20 dBm

With an Attenuator: -120 dBm

Minimum Leveled Output Power

Without an Attenuator: -15 dBm (-20 dBm, typical)

With an Attenuator: -115 dBm (MG3691C, MG3692C, MG3693C, and MG3694C)
-105 dBm (MG3695C, and MG3697C)

With an Electronic Attenuator: -125 dBm (MG3691C)

Unleveled Output Power Range (typical)

Without an Attenuator: > 40 dB below max power.

With an Attenuator: > 130 dB below max power.

Power Level Switching Time (to within specified accuracy)

Without Change in Step Attenuator: < 3 ms typical

With Change in Step Attenuator: < 20 ms typical

With Change in Electronic Step Attenuator: < 3 ms typical. Power level changes across -70 dB step will result in 20 ms delay.

Step Attenuator (Option 2)

Adds a 10 dB/step attenuator, with 110 dB range on models ≤ 40 GHz, and 90 dB range on models > 40 GHz. Option 2E adds an electronic version with 120 dB range, only available on an MG3691C. Option 2E is not available on units with Option 22, coverage down to 0.1 Hz.

Accuracy and Flatness

Accuracy specifies the total worst case accuracy. Flatness is included within the accuracy specification.

Step Sweep and CW Modes:

Attenuation Below Max Power	Frequency (GHz)			
	≤ 40**	40-50	50-60	60-67
Accuracy:				
0 dB - 25 dB	± 1.0 dB	± 1.5 dB	± 1.5 dB	± 1.5 dB
25 dB - 60 dB	± 1.0 dB	± 1.5 dB	± 3.5 dB*	N/A
60 dB - 100 dB	± 1.0 dB	± 2.5 dB*	± 3.5 dB*	N/A
Flatness:				
0 dB - 25 dB	± 0.8 dB	± 1.1 dB	± 1.1 dB	± 1.1 dB
25 dB - 60 dB	± 0.8 dB	± 1.1 dB	± 3.1 dB*	N/A
60 dB - 100 dB	± 0.8 dB	± 2.1 dB*	± 3.1 dB*	N/A

*Typical

**Accuracy and Flatness with high power Option 15, is ±1.5 dB. It is also ±1.5 dB below 20 MHz, with or without Option 15.

Analog Sweep Mode (typical):

Attenuation Below Max Power	Frequency (GHz)			
	0.01-0.05	0.05-20	20-40	40-67
Accuracy:				
0 dB - 12 dB	± 2.0 dB	± 2.0 dB	± 2.0 dB	± 3.0 dB
12 dB - 30 dB	± 3.5 dB	± 3.5 dB	± 4.6 dB	± 5.6 dB
30 dB - 60 dB	± 4.0 dB	± 4.0 dB	± 5.2 dB	± 6.2 dB
60 dB - 122 dB	± 5.0 dB	± 5.0 dB	± 6.2 dB	± 7.2 dB
Flatness:				
0 dB - 12 dB	± 2.0 dB	± 2.0 dB	± 2.0 dB	± 2.5 dB
12 dB - 30 dB	± 3.5 dB	± 3.5 dB	± 4.1 dB	± 5.1 dB
30 dB - 60 dB	± 4.0 dB	± 4.0 dB	± 4.6 dB	± 5.6 dB
60 dB - 122 dB	± 5.0 dB	± 5.0 dB	± 5.2 dB	± 6.2 dB

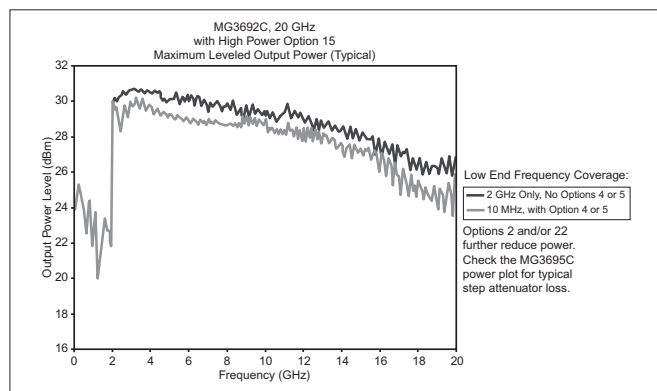

Typical MG3692C maximum available output power

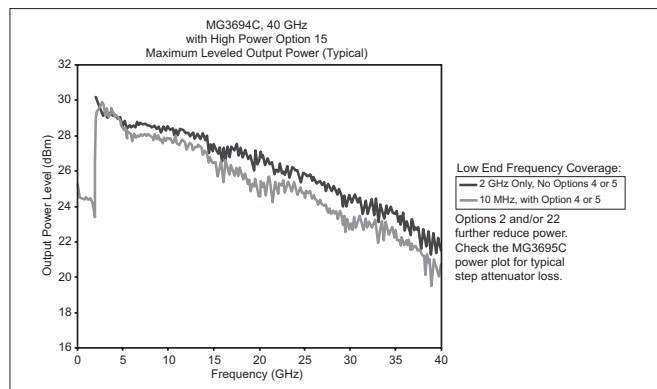

Typical MG3694C maximum available output power

Other Output Power Specifications

Output Units: Output units selectable as either dBm or mV. Selection of mV assumes 50 Ω load. All data entry and display are in the selected units.

Output Power Resolution: 0.01 dB or 0.001 mV

Source Impedance: 50 Ω nominal

Source SWR (Internal Leveling): < 2.0 typical

Power Level Stability with Temperature: 0.04 dB/deg C typical

Level Offset: Offsets the displayed power level to establish a new reference level.

Output On/Off: Toggles the RF output between an Off and On state. During the Off state, the RF oscillator is turned off. The On or Off state is indicated by two LEDs located below the OUTPUT ON/OFF key on the front panel.

RF On/Off Between Frequency Steps: System menu selection of RF On or RF Off during frequency switching in CW, Step Sweep, and List Sweep modes.

RF On/Off During Retrace: System menu selection of RF On or RF Off during retrace.

Internal Leveling: Power is leveled at the output connector in all modes.

External Leveling:

External Detector: Levels output power at a remote detector location. Accepts a positive or negative 0.5 mV to 500 mV input signal from the remote detector. L1 adjusts the input signal range to an optimum value. BNC connector, rear panel.

External Power Meter: Levels output power at a remote power meter location. Accepts a ± 1 V full scale input signal from the remote power meter. L1 adjusts the input signal range to an optimum value. BNC connector, rear panel.

External Leveling Bandwidth: 30 kHz typical in Detector mode. 0.7 Hz typical in Power Meter mode.

User Level Flatness Correction:

Number of points: 2 to 801 points per table

Number of tables: 5 available

Entry modes: GPIB power meter or computed data

CW Power Sweep

Range: Sweeps between any two power levels at a single CW frequency.
Resolution: 0.01 dB/step (Log) or 0.001 mV (Linear)

Accuracy: Same as CW power accuracy.

Log/Linear Sweep: Power sweep selectable as either log or linear. Log sweep is in dB; linear sweep is in mV.

Step Size: User-controlled, 0.01 dB (Log) or 0.001 mV (Linear) to the full power range of the instrument.

Step Dwell Time: Variable from 1 ms to 99 seconds. If the sweep crosses a step attenuator setting, there will be a sweep dwell of approximately 20 ms to allow setting of the step attenuator.

Sweep Frequency/Step Power

A power level step occurs after each frequency sweep. Power level remains constant for the length of time required to complete each sweep.

Internal Power Monitor (Option 8)

Sensors: Compatible with Anritsu 560-7, 5400-71, or 6400-71 series detectors. Rear panel input.

Range: +16 dBm to -35 dBm

Accuracy: ± 1 dBm, (+16 dBm to -10 dBm)
± 2 dBm, (-10 dBm to -35 dBm)

Resolution: 0.1 dBm minimum

Modulation

Frequency/Phase Modulation (Option 12)

Option 12 adds frequency and phase modulation, driven externally via a rear panel BNC connector, 50 Ω. For internal modulation, add Internal LF Generator and Pulse Generator Option 27. Frequency/Phase Modulation is not available <10 MHz with Option 22.

For the most accurate FM and ΦM measurements, Bessel Null methods are used. When verifying FM and ΦM, the use of the "carrier null" technique is recommended. Measured residual FM effects must be subtracted from modulation meter measurements.

Frequency Generator Multiplication/Division Ratios:

Frequency Range	Divide Ratio, n
< 10 MHz (Option 22)	modulation not available
≥ 10 MHz to ≤ 15.625 MHz (Option 4)	256
> 15.625 MHz to ≤ 31.25 MHz (Option 4)	128
> 31.25 MHz to ≤ 62.5 MHz (Option 4)	64
> 62.5 MHz to ≤ 125 MHz (Option 4)	32
> 125 MHz to ≤ 250 MHz (Option 4)	16
> 250 MHz to ≤ 500 MHz (Option 4)	8
> 500 MHz to ≤ 1050 MHz (Option 4)	4
> 1050 MHz to ≤ 2200 MHz (Option 4)	2
> 10 MHz to ≤ 2000 MHz (Option 5)	1
> 2 GHz to ≤ 20 GHz	1
> 20 GHz to ≤ 40 GHz	1/2
> 40 GHz to ≤ 67 GHz	1/4

Frequency Modulation:

Parameter	Modes	Conditions	Specifications	Conditions	Specifications
		for all Frequencies other than < 2.2 GHz with Option 4		for Frequencies < 2.2 GHz with Option 4	
Deviation	Locked	Rate= 1 kHz to 8 MHz	± [Lesser of 10 MHz or 300 * (mod rate)]/n	Rate = 1 kHz to (Lesser of 8 MHz or 0.03 * Fcarrier)	± [Lesser of 10 MHz or 300 * (mod rate)]/n
	Locked Low-noise	Rate= 50 kHz to 8 MHz	± [Lesser of 10 MHz or 3 * (mod rate)]/n	Rate = 50 kHz to (Lesser of 8 MHz or 0.03 * Fcarrier)	± [Lesser of 10 MHz or 3 * (mod rate)]/n
	Unlocked Narrow	Rate= DC to 8 MHz	± 10 MHz/n	Rate = DC to (Lesser of 8 MHz or 0.03 * Fcarrier)	± (10 MHz)/n
	Unlocked Wide	Rate= DC to 100 Hz	± 100 MHz/n	Rate = DC to 100 Hz	± (100 MHz)/n
Bandwidth (3 dB)	Locked		1 kHz to 10 MHz		1 kHz to (Lesser of 10 MHz or 0.03 * Fcarrier)
	Locked Low-noise		30 kHz to 10 MHz		30 kHz to (Lesser of 8 MHz or 0.03 * Fcarrier)
	Unlocked Narrow		DC to 10 MHz		DC to (Lesser of 10 MHz or 0.03 * Fcarrier)
	Unlocked Wide		DC to 100 Hz		DC to 100 Hz
Flatness	Locked	Rate= 10 kHz to 1 MHz	± 1 dB relative to 100 kHz	Rate = 10 kHz to (Lesser of 1 MHz or 0.01 * Fcarrier)	± 1 dB relative to 100 kHz
Accuracy	Locked and Low-noise Unlocked Narrow	Rate= 100 kHz sinewave Int. or 1 Vpk Ext.	10% (5% typical)	Rate= 100 kHz sinewave Int. or 1 Vpk Ext.	10% (5% typical)
Incidental AM	Locked and Low-noise Unlocked Narrow	1 MHz Rate, ± 1 MHz Dev.	< 2% typical	Rate and Dev.= Lesser of 1 MHz or 0.01 * Fcarrier	< 2% typical
Harmonic Distortion	Locked	10 kHz Rate, ± 1 MHz Dev.	< 1%	Rate = 10 kHz, Dev.= ± (1 MHz)/n	< 1%
External Sensitivity	Locked	(± 1V maximum input)	± (10 kHz/V to 20 MHz/V)/n	(± 1 Vpk maximum input)	± (10 kHz/V to 20 MHz/V)/n
	Locked Low-noise		"		"
	Unlocked Narrow		"		"
	Unlocked Wide		± (100 kHz/V to 100 MHz/V)/n		± (100 kHz/V to 100 MHz/V)/n

Phase Modulation:

Parameter	Modes	Conditions	Specifications	Conditions	Specifications
		for all Frequencies other than < 2.2 GHz with Option 4		for Frequencies < 2.2 GHz with Option 4	
Deviation	Narrow	Rate= DC to 8 MHz	± [Lesser of 3 rad or (5 MHz/mod rate)]/n	Rate = DC to (Lesser of 8 MHz or 0.03 * Fcarrier)	± [Lesser of 3 rad or (5 MHz/mod rate)]/n
	Wide	Rate= DC to 1 MHz	± [Lesser of 400 rad or (10 MHz/mod rate)]/n	Rate = DC to (Lesser of 1 MHz or 0.03 * Fcarrier)	± [Lesser of 400 rad or (10 MHz/mod rate)]/n
Bandwidth (3 dB)	Narrow		DC to 10 MHz		DC to (Lesser of 10 MHz or 0.03 * Fcarrier)
	Wide		DC to 1 MHz		DC to (Lesser of 1 MHz or 0.03 * Fcarrier)
Flatness	Narrow	Rate= DC to 1 MHz	± 1 dB relative to 100 kHz	Rate = DC to (Lesser of 1 MHz or 0.01 * Fcarrier)	± 1 dB relative to 100 kHz rate
	Wide	Rate= DC to 500 kHz	± 1 dB relative to 100 kHz	Rate = DC to (Lesser of 500 kHz or 0.01 * Fcarrier)	± 1 dB relative to 100 kHz rate
Accuracy	Narrow and Wide	100 kHz Internal or 1Vpk External, sine	10%	100 kHz Internal or 1 Vpk External, sine	10%
External Sensitivity	Narrow	(± 1 V maximum input)	± (0.0025 rad/V to 5 rad/V)/n	(± 1 Vpk maximum input)	± (0.0025 rad/V to 5 rad/V)/n
	Wide		± (0.25 rad/V to 500 rad/V)/n		± (0.25 rad/V to 500 rad/V)/n

Amplitude Modulation (Option 14)

Option 14 adds amplitude modulation, driven externally via a rear panel BNC connector 50 Ω . For internal modulation, add Internal LF and Pulse Generators Option 27.

All amplitude modulation specifications apply at 50% depth, 1 kHz rate, with RF level set 6 dB below maximum specified leveled output power, unless otherwise noted. Amplitude Modulation is not available < 10 MHz with Option 22.

AM Depth (typical): 0-90% linear; 20 dB log

AM Bandwidth* (3 dB):
DC to 50 kHz minimum
DC to 100 kHz typical

Flatness (DC to 10 kHz rates): ± 0.3 dB

Accuracy: Reading $\pm 5\%$

Distortion: < 5% typical

Incidental Phase Modulation (30% depth, 10 kHz rate):
< 0.2 radians typical

External AM Input: Log AM or Linear AM input, rear-panel BNC, 50 Ω input impedance. For internal modulation, add LF Generator Option 27.

Sensitivity:

Log AM: Continuously variable from 0 dB per volt to 25 dB per volt.
Linear AM: Continuously variable from 0% per volt to 100% per volt.

Maximum Input: ± 1 Vpk

*Typical below 2.2 GHz, when ordered with Options 4 and 15.

Pulse Modulation (Option 26)

Option 26 adds pulse modulation, driven externally via a rear panel BNC connector, TTL. For internal modulation, add Internal LF and Pulse Generators Option 27.

Pulse modulation specifications apply at maximum rated power, unless otherwise noted. Pulse modulation is not available < 10 MHz with Option 22.

On/Off Ratio: > 80 dB (> 70 dB with high power Option 15)

Minimum Leveled Pulse Width:

100 ns, ≥ 1 GHz
1 μ s, < 1 GHz

Minimum Unleveled Pulse Width: < 10 ns

Level Accuracy Relative to CW (100 Hz to 1 MHz PRF):

± 0.5 dB, ≥ 1 μ s pulse width
 ± 1.0 dB, < 1 μ s pulse width

Pulse Delay (typical): 50 ns in External Mode

PRF Range:

DC to 10 MHz, unleveled
100 Hz to 5 MHz, leveled

Frequency Range	Rise and Fall Time (10% to 90%)	Overshoot	Pulse Width Compression	Video Feedthrough
≥ 10 MHz to < 31.25 MHz (Opt. 4)	400 ns*	33%*	40 ns*	± 70 mV*
≥ 31.25 MHz to < 125 MHz (Opt. 4)	90 ns*	22%*	12 ns*	± 130 mV*
≥ 125 MHz to < 500 MHz (Opt. 4)	33 ns*	11%*	12 ns*	± 70 mV*
≥ 500 MHz to < 2200 MHz (Opt. 4)	15 ns*	10%	12 ns*	± 50 mV*
≥ 10 MHz to < 1000 MHz (Opt. 5)	15 ns, 10 ns*	10%	8 ns*	± 30 mV*
≥ 1 GHz to < 2 GHz (Opt. 5)	10 ns, 5 ns*	10%	8 ns*	± 30 mV*
≥ 2 GHz to 67 GHz ^①	10 ns, 5 ns*	10% ^①	8 ns*	± 30 mV*

External Input: Rear-panel BNC. For internal modulation, add Pulse Generator Option 27

Drive Level: TTL compatible input

Input Logic: Positive-true or negative-true, selectable from modulation menu.

Internal LF and Pulse Generators (Option 27)

An internal pulse generator and two internal waveform generators are added, one providing a frequency or phase modulating signal and the other an amplitude modulating signal. This Internal LF and Pulse Generators option can only be ordered in combination with either FM/ Φ M, AM, or Pulse options, 12, 14, and 26 respectively.

Waveforms: Sinusoid, square-wave, triangle, positive ramp, negative ramp, Gaussian noise, uniform noise. (Check Option 10 for User-Defined)

Rate:

0.1 Hz to 10 MHz sinusoidal
0.1 Hz to 1 MHz square-wave, triangle, ramps

Resolution: 0.1 Hz

Accuracy: Same as instrument timebase ± 0.014 Hz

Waveform Outputs: Two BNC connectors on the rear panel, FM/ Φ M OUT and AM OUT

Pulse Modes: Singlet, doublet, triplet, quadruplet

Pulse Triggers: Free-run, triggered, gated, delayed, triggered with delay, swept-delay

Pulse Inputs/Outputs: Video pulse and sync out, rear-panel BNC connectors

Pulse Parameter	Selectable Clock Rate	
	Narrow (100 MHz)	Wide (10 MHz)
Pulse Width	10 ns to 160 ms	100 ns to 1.6 s
Pulse Period ^②	100 ns to 160 ms	600 ns to 1.6 s
Variable Delay		
Singlet	0 ms to 160 ms	0 s to 1.6 s
Doublet	100 ns to 160 ms	300 ns to 1.6 s
Triplet	100 ns to 160 ms	300 ns to 1.6 s
Quadruplet	100 ns to 160 ms	300 ns to 1.6 s
Resolution	10 ns	100 ns
Accuracy	10 ns (5 ns typical)	10 ns (5 ns typical)

Ultra-Stable Phase Tracking (Option 36)

Option 36 enables up to three MG3690C units fitted with option 3, 3X to phase track with a very high degree of stability. Option 36 provides additional rear panel connectors to link internal reference signals together

100 MHz Reference Output: Provides the reference signal to drive up to two other MG3690C. All must have Option 36 and either option 3 or 3x. This signal is only intended for use with other Option 36 instruments.

100 MHz Reference Input: Accepts the 100 MHz reference signal from another MG3690C fitted with Option 36. This input is only intended for use with other Option 36 instruments.

Phase Drift: $< \pm 1^\circ$ over 5 seconds (typical), $< \pm 1.5^\circ$ over 100 seconds (typical), after 24 hours warm-up time.

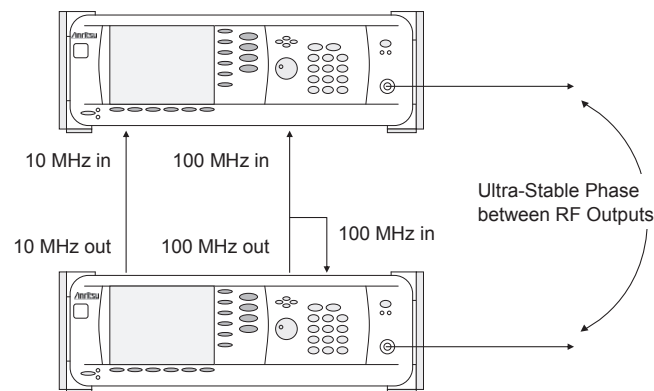

① For 50 GHz and 67 GHz units, overshoot > 40 GHz is 20% typical at rated power.

② Period must be longer than the sum of delay and width by 5 clock cycles minimum.

③ Rise time and Pulse Width Compression, > 20 GHz, degrades by 2 ns, with High Power Option 15.

* Typical

IF Up-Conversion (Option 7)

Option 7 adds an internal mixer that can be used for the generic up-conversion of an IF signal. The mixer's RF, LO, and IF ports are made available at the rear panel of the MG3690C, via three female K-Connectors. The typical application will feed the MG3690C microwave output, which can be moved to the rear panel via option 9K, to the mixer's LO port. An external IF signal will be fed to the mixer's IF port. The new up-converted signal will be available at the mixer's RF port.

Mixer Type	Double Balanced
RF, LO Range	1 GHz to 40 GHz
IF Range	DC to 700 MHz
Conversion Loss	10 dB Typical
Max Power into any Port	23 dBm @ 25 °C
Isolation, RF to LO	30 dB
LO Drive Level (recommended)	+10 dBm to +13 dBm
Input P1 dB	+3 dBm Typical

The IF Up-Conversion option is particularly useful to create a microwave frequency IQ-modulated signal. Lower frequency IQ-modulated RF sources are readily available, such as the Anritsu MG3700A. Option 7's IF input can be used to feed in an IQ-modulated signal from an MG3700A, up-converting it to as high as 40 GHz with an MG3694C. A typical setup is shown below.

User-Defined Modulation Waveform Software (Option 10)

An external software package provides the ability to download user-defined waveforms into the internal LF Generator's (Option 27) memory. The MG3690C provides as standard with the LF Generator sinusoidal, square-wave, triangle, positive ramp, Gaussian noise, and uniform noise waveforms.

Two look-up tables of 65,536 points can be used to generate two pseudo-random waveforms, one for amplitude modulation and the other for frequency or phase modulation. The download files are simple space-delimited text files containing integer numbers between 0 and 4095, where 0 corresponds to the minimum modulation level and 4095 the maximum.

In addition to the capability of downloading custom waveforms, the software offers a virtual instrument modulation panel. Custom modulation setups with user waveforms can be stored for future use. For IFF signal simulation, the internal generators can be synchronized. They can also be disconnected from the internal modulators, making the low frequency waveforms available at the rear panel for external purposes.

Scan Modulation (Option 20)

Option 20 adds a microwave linearly controlled attenuator to provide deep AM capability. This modulator is inserted outside the leveling loop but before the optional step attenuator. It is switched in and out of the RF path. Scan modulation is driven externally only.

One application of this feature is storing an antenna pattern wave form in memory and using it to feed the external input to the scan modulator, Option 20.

Frequency Range	2 GHz to 18 GHz
Attenuation Range	0 dB to 60 dB
Flatness/Accuracy	± 1.5 dB/± 1.5 dB, 0 to 40 dB ± 3 dB/± 2 dB, 40 to 60 dB
Step Response	< 1 µs
Sensitivity	-10 dB/V
Modulation Bandwidth	20 kHz (small signal) 5 kHz (large signal)
Insertion Loss	< 6 dB (when engaged)
Input	Rear Panel BNC connector High Impedance

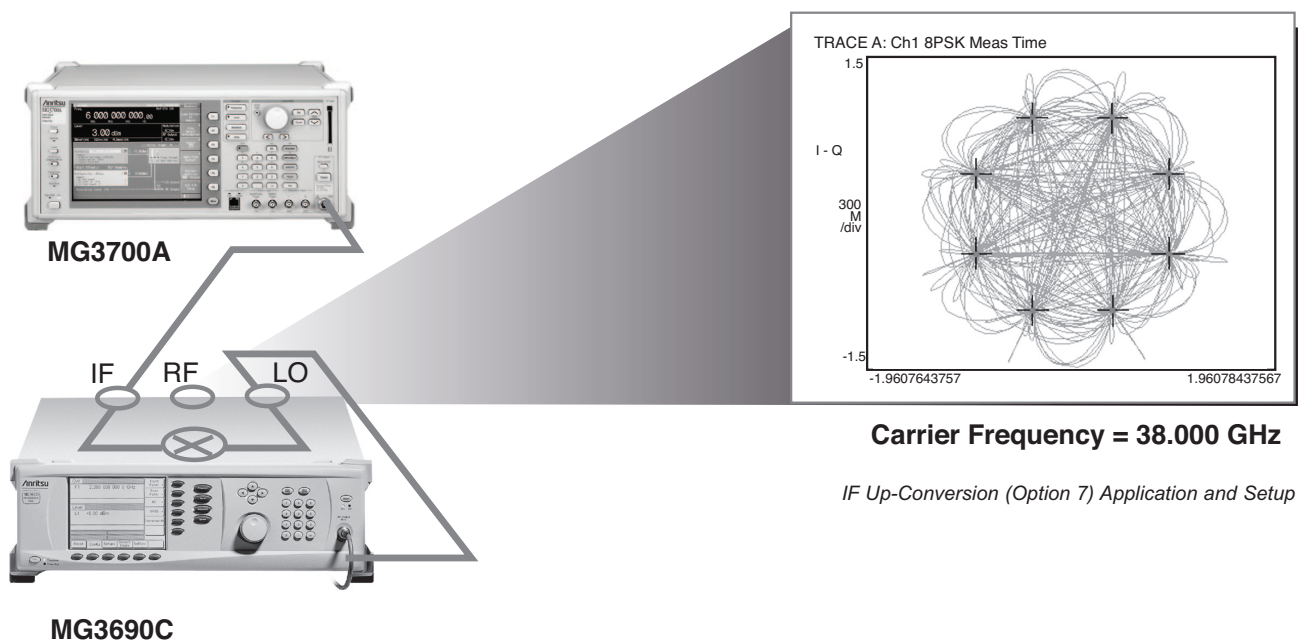

mmW Frequency Coverage

Millimeter Wave Multipliers¹ - 63850 series (Option 18 recommended for DC bias.)

63850 series external, waveguide output, multipliers are available for banded frequency coverage up to 325 GHz.

These external multipliers require at a minimum an MG3692C, with 20 GHz coverage. The output power required to drive the modules is +10 dBm. They can be powered up by an external power supply (+12 Vdc, 1.5A typ.) using the supplied double banana power cord. It is recommended to purchase an MG3690C with option 18, which adds the capability to bias these modules without the need of an additional power supply. Option 18 adds a rear panel Twinax connector that supplies the proper DC bias for these modules, and a cable to power them up. Option 18 is not available with options 7 and 15.

63850 series multipliers have a saturated, unlevelled, output power, yet their inherent flatness is exceptional. Modulating the input drive will indeed modulate the output, except for the case of Amplitude Modulation. Since the output is saturated, Amplitude Modulation is not recommended with these mmW modules. Frequency and Phase Modulation is possible, but the achieved deviation will be multiplied based on the multiplication factor of the module. Pulse modulation is also possible, with even sharper rise and fall times than the input. All modulation performances are not specified.

For ease of operation, the MG3690C allows the user to enter a frequency scaling factor, the module's multiplication factor, which will be used only for purposes of displaying the proper frequency at the output of the mmW module, on the MG3690C front panel display.

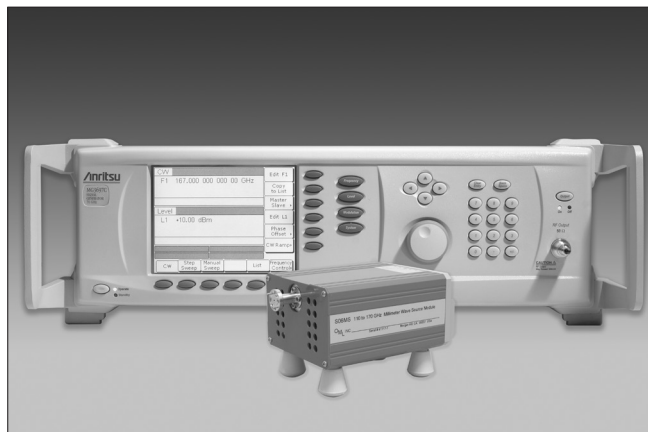

MG3690C with 63850 Series Millimeter Wave Multiplier

Multiplier p/n ¹	63850-15	63850-12	63850-10	63850-08	63850-06	63850-05	63850-03
Frequency	50 GHz - 75 GHz	60 GHz - 90 GHz	75 GHz - 110 GHz	90 GHz - 140 GHz	110 GHz - 170 GHz	140 GHz - 220 GHz	220 GHz - 325 GHz
Waveguide Output	WR-15	WR-12	WR-10	WR-08	WR-06	WR-05	WR-03
Flange ²	(008)	(009)	(010)	(M08)	(M06)	(M05)	(M03)
Output Power (typical)	+8 dBm	+6 dBm	+5 dBm	-5 dBm	-13 dBm	-15 dBm ³	-25 dBm ⁴
Output Flatness (typical) (Unlevelled)	± 2 dB	± 2 dB	± 3 dB	—	—	—	—
Output Match	> 12 dB	> 12 dB	> 12 dB	> 12 dB	> 12 dB	> 12 dB	6 dB (typical)
Multiplication Factor (m)	x4	x6	x6	x8	x12	x12	x18
Input Frequency	12.5 GHz - 18.75 GHz	10.0 GHz - 15.0 GHz	12.5 GHz - 18.4 GHz	11.2 GHz - 17.5 GHz	9.1 GHz - 14.2 GHz	11.6 GHz - 18.4 GHz	12.2 GHz - 18.1 GHz
Frequency Accuracy	(LO Synthesizer's Accuracy x m)						
Frequency Resolution	(LO Synthesizer's Resolution x m)						
Harmonics & Spurious	-15 dBc (typical)						
Input Power Required	+10 dBm						
RF Input Connector	SMA (female)						
DC Power	12 Vdc, 1.5A (double banana power cord included) Option 18 is recommended on the synthesizer, to supply the necessary bias.						
Dimensions	120 mm x 110 mm x 70 mm (not including feet or interfaces)						
Weight	< 1 kg						
Temperature	+20 °C to +30 °C						

¹ These mmW modules are produced by OML Inc. (Oleson Microwave Labs), located in Morgan Hill, CA., with mutual collaborative experiences over many years. For detailed and up-to-date specifications, please call OML, Inc. or visit their website at www.oml-mmw.com.

² Waveguide output flanges are per MIL-F-3922/67B-(xxx)

³ Power rolls off from -15 dBm at 200 GHz, to -25 dBm typical at 220 GHz.

⁴ Output power is estimated.

Inputs and Outputs*

EXT ALC IN	Provides for leveling the RF output signal externally with either a detector or power meter. Signal requirements are shown in the RF Output specifications. BNC type, rear panel.	SERIAL I/O	Provides access to RS-232 terminal ports to support service and calibration functions and master-slave operations. RJ45 type, rear panel.
RF OUTPUT** (Option 9)	Provides for RF output from 50 Ω source impedance. Option 9 moves the RF Output connector from the front to the rear panel. K Connector (female) fmax ≤ 40 GHz V Connector (female) fmax ≥ 40 GHz.	IEEE-488 GPIB	Provides input/output connections for the General Purpose Interface Bus (GPIB). Type 57, rear panel.
10 MHz REF IN	Accepts an external 10 MHz ± 50 Hz, 0 dBm to +20 dBm time-base signal. Automatically disconnects the internal high-stability time-base option, if installed. 50 Ω impedance. BNC type, rear panel.	mmW BIAS** (Option 18)	Provides the bias for the external waveguide multipliers for coverage up to 325 GHz. Twinax, rear panel.
10 MHz REF OUT	Provides a 1 Vp-p, AC coupled, 10 MHz signal derived from the internal frequency standard. 50 Ω impedance. BNC type, rear panel.	RF, LO, IF** (Option 7)	Provides access to an internal IF up-conversion mixer. K Connector (female) 3X, rear panel.
100 MHz REF IN (Option 36)	Accepts the 100 MHz signal from an MG3690C with Option 36 for ultra-stable phase tracking.	PULSE TRIG IN (Option 26)	Accepts an external TTL compatible signal to pulse modulate the RF output signal or to trigger or to gate the optional internal pulse generator. BNC type, rear panel.
100 MHz REF OUT (Option 36)	Provides the 100 MHz signal for an MG3690C with Option 36 ultra-stable phase tracking.	PULSE SYNC OUT (Option 27)	Provides a TTL compatible signal, synchronized to the internal pulse modulation output. BNC type, rear panel.
HORIZ OUT (Horizontal Sweep Output)	Provides 0V at beginning and +10V at end of sweep, regardless of sweep width. In CW mode, the voltage is proportional to frequency between 0V at low end and +10V at the high end of range. In CW mode, if CW RAMP is enabled, a repetitive, 0V to +10V ramp is provided. BNC type, rear panel.	PULSE VIDEO OUT (Option 27)	Provides a video modulating signal from the internal pulse generator. BNC type, rear panel.
EFC IN	Provides the capability to frequency modulate the internal crystal oscillator, allowing phase locking the synthesizer inside an external lock loop. Specifications on page 2. BNC type, rear panel.	AM IN (Option 14)	Accepts an external signal to amplitude modulate the RF output signal, 50 Ω impedance. BNC type, rear panel.
AUX I/O (Auxiliary Input/Output)	Provides for most of the rear panel BNC connections through a single, 25-pin, D type connector. Supports master-slave operation with another synthesizer or allows for a single-cable interface with the Model 56100A Scalar Network Analyzer and other Anritsu instruments (see figure below). 25 pin D-type, rear panel.	FM/ΦM IN (Option 12)	Accepts an external signal to frequency or phase modulate the RF output signal. 50 Ω impedance. BNC type, rear panel.
		AM OUT (Option 27)	Provides the amplitude modulation waveform from the internal LF generator. BNC type, rear panel.
		FM/ΦM OUT (Option 27)	Provides the frequency or phase modulation waveform from the internal LF generator. BNC type, rear panel.
		SCAN MOD IN** (Option 20)	Accepts an external signal to scan modulate the RF output signal. High Impedance. BNC type, rear panel.
		POWER MONITOR IN (Option 8)	Accepts an external detector for power monitoring. Custom type, rear panel.

*Connectors may be available but not active, if option is not ordered.

**Options (7 & 18), (7 & 20), (8 & 9) are mutually exclusive, as they share the same rear panel space.



MG3690C Rear Panel

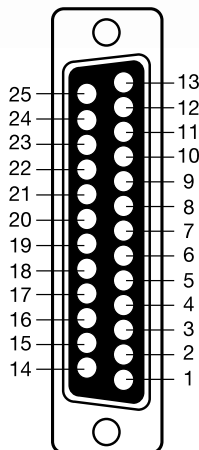

Aux I/O pins:

- | | |
|--------------------------------|-----------------------------------|
| 1. Horizontal Output | 14. V/GHz Output |
| 2. Chassis Ground | 15. End-of-Sweep Input |
| 3. Sequential Sync Output | 16. End-of-Sweep Output |
| 4. Low Alternate Enable Output | 17. - |
| 5. Marker Output | 18. Sweep Dwell Input |
| 6. Retrace Blanking Output | 19. - |
| 7. Low Alternate Sweep Output | 20. Bandswitch Blanking Output |
| 8. Chassis Ground | 21. Master Reset |
| 9. - | 22. Horizontal Sweep Input |
| 10. Sweep Dwell Output | 23. Horizontal Sweep Input Return |
| 11. Lock Status Output | 24. Chassis Ground |
| 12. Penlift | 25. Memory Sequencing Input |
| 13. External Trigger Input | |

Ordering Information

Models

MG3691C	2 GHz to 10 GHz Signal Generator
MG3692C	2 GHz to 20 GHz Signal Generator
MG3693C	2 GHz to 31.8 GHz Signal Generator
MG3694C	2 GHz to 40 GHz Signal Generator
MG3695C	2 GHz to 50 GHz Signal Generator
MG3697C	2 GHz to 67 GHz Signal Generator (operational to 70 GHz)

Standard (included) Accessories

2300-469	<p>Software for MG3690X</p> <ul style="list-style-type: none"> • Operation Manual • Programming Manual • SCPI Programming Manual • IVI Drivers • Technical Datasheet <p>Power Cord with plug-type and rating determined by destination country</p> <p>3 Year Factory Warranty</p>
----------	--

Options and Accessories

MG3690C/1A	Rack Mount with slides – Rack mount kit containing a set of track slides (90 degree tilt capability), mounting ears, and front panel handles to let the instrument be mounted in a standard 19-inch equipment rack.
MG3690C/1B	Rack Mount without slides – Modifies rack mounting hardware to install unit in a console that has mounting shelves. Includes mounting ears and front panel handles.
MG3690C/2A MG3690C/2B MG3690C/2C	Mechanical Step Attenuator – Adds a 10 dB/step attenuator. Rated RF output power is reduced. (This option comes in different versions, based on instrument configuration)
MG3690C/2E	Electronic Step Attenuator – Adds a 10 dB/step electronic attenuator with a 120 dB range for the MG3691C. Rated RF output power is reduced. (Not available with Option 20 or 22)
MG3690C/3	Ultra Low Phase Noise – Adds new modules to significantly reduce SSB phase noise. (Not available with Option 3X)
MG3690C/3X	Premium Phase Noise, improves Option 3 (< 1 kHz offset). (Not available with Option 3)
MG3690C/4	8 MHz to 2.2 GHz RF coverage, Ultra-Low Phase Noise version – Uses a digital down converter to significantly reduce SSB phase noise. All specifications apply \geq 10 MHz.
MG3690C/5	8 MHz to 2 GHz RF coverage – Uses an analog down converter. All specifications apply \geq 10 MHz.
MG3690C/6	Analog Sweep Capability – (limited to \geq 500 MHz when used with Option 4)
MG3690C/7	IF Up-Conversion – Adds an internal 40 GHz mixer for up-converting an IF signal. (Not available with MG3695C, MG3697C, or with Options 18, 20 or 36)
MG3690C/8	Power Monitor – Adds internal power measurement capability. (Not available with Option 9)
MG3690C/9K MG3690C/9V	Rear Panel Output – Moves the RF output connector to the rear panel. (This option comes in different versions, based on instrument configuration) (Not available with Option 8)
MG3690C/10	User-Defined Modulation Waveform Software – External software package provides the ability to download user-defined waveforms into the memory of the internal waveform generator, serially or via GPIB. External PC and an instrument with LF Generator, Option 27, are required.

MG3690C/12	Frequency and Phase Modulation – External, via a rear panel BNC connector. For internal modulation capability, requires additionally LF Generator, Option 27.
MG3690C/14	Amplitude Modulation – External, via a rear panel BNC connector. For internal modulation capability, requires additionally LF Generator, Option 27.
MG3690C/15A MG3690C/15B MG3690C/15C MG3690C/15D	High Power – Adds high-power RF components to the instrument to increase its output power level. (This option comes in different versions, based on instrument configuration)
MG3690C/16	High Stability Time Base – Adds an ovenized, 10 MHz crystal oscillator as a high-stability time base.
MG3690C/17	Delete Front Panel – Deletes the front panel for use in remote control applications where a front panel display and keyboard control are not needed. (Only available with Options 1A or 1B)
MG3690C/18	mmW Bias Output – Adds a rear panel BNC Twinax connector required to bias the 63850 series millimeter wave source modules, sold separately. Includes DC bias cable. (Not available with Option 7 or 15x)
MG3690C/20	Scan Modulation – Adds an internal Scan modulator for simulating high-depth amplitude modulated signals. Requires an external modulating signal input capability. (Not available on models MG3693C, MG3694C, MG3695C, MG3697C, or with Options 2E, 7, 15X, or 22)
MG3690C/22	0.1 Hz to 10 MHz Audio coverage – Uses a DDS for coverage down to approximately DC. When adding Option 22, the output power is derated by 2 dB. The frequency resolution below 10 MHz is 0.02 Hz. No modulation is available in the 0.1 Hz to 10 MHz band. (Not available without Option 4 or 5, or with Option 20 or 2E)
MG3690C/26A MG3690C/26B	Pulse Modulation – External, via a rear panel BNC connector. For internal modulation capability, requires additionally Pulse Generator, Option 27. (This option comes in different versions, based on instrument configuration)
MG3690C/27	Internal LF and Pulse Generators – Provides modulation waveforms for internal AM, FM, Φ M and Pulse. (Not available without Option 12, 14, or 26)
MG3690C/28A MG3690C/28B	Analog Modulation Suite – For ease of ordering and package pricing, this option bundles Options 12, 14, 26 and 27, offering internal and external AM, FM, Φ M, and Pulse Modulation. (This option comes in different versions, based on instrument configuration)
MG3690C/36	Ultra-Stable Phase Tracking - Provides the capability for ultra-stable phase tracking between instruments using the internal 100 MHz reference. (Requires Option 3 or 3x) (Not available with Option 7 or with both Option 18 and 20 together)

Millimeter Wave Accessories (Option 18 recommended for DC bias)

63850-15	50 GHz to 75 GHz V band Multiplier Source Module, WR-15
63850-12	60 GHz to 90 GHz E band Multiplier Source Module, WR-12
63850-10	75 GHz to 110 GHz W band Multiplier Source Module, WR-10
63850-08	90 GHz to 140 GHz F band Multiplier Source Module, WR-08
63850-06	110 GHz to 170 GHz D band Multiplier Source Module, WR-06
63850-05	140 GHz to 220 GHz G band Multiplier Source Module, WR-05
63850-03	220 GHz to 325 GHz H band Multiplier Source Module, WR-03
806-121	SMA male-male flexible cable, 90 cm (3 ft) (could be used to connect the MG3690C output to the module's LO input)

Accessories

34RKNF50	DC to 20 GHz, Ruggedized Type N female adapter for units with a K connector output
ND36329	MASTER/SLAVE interface cable set
63270	Transit case (16 kg, 66 cm x 41 cm x 81 cm, roll-away on four wheels)
2300-469	IVI Driver, includes LabView® driver
806-97	Aux I/O Cable, 25 pin to BNC: Provides BNC access to Aux I/O Data Lines: Sequential Sync, Marker Out, Bandswitch Blanking, Retrace Blanking, Sweep Dwell In, V/GHz, Horizontal Out.

10370-10373	Operation Manual (For MG3690C Models)
10370-10374	Programming Manual (Native) (For MG3690C Models)
10370-10375	Programming Manual (SCPI) (For MG3690C Models)
10370-10376	Maintenance Manual (For MG3690C Models)

Upgrades

Economical upgrades are available to upgrade any model to any higher performing model. Consult Anritsu for details.

MG3690C OPTION CONFIGURATION GUIDE – Important: Please see footnotes where applicable

MODELS	OPTIONS																	
	OPT 1		OPT 2				OPT 3	OPT 3X	OPT 4	OPT 5	OPT 6	OPT 7	OPT 8	OPT 9		OPT 10	OPT 12	OPT 14
	1A	1B	2A	2B	2C	2E								9K	9V			
MG3691C	•	•	•			• _{9,11}	• ₁₃	• ₁₃	• ₁	• ₁	•	• _{2,12,15}	• ₈	• ₈		• ₃	•	•
MG3692C	•	•	•				• ₁₃	• ₁₃	• ₁	• ₁	•	• _{2,12,15}	• ₈	• ₈		• ₃	•	•
MG3693C	•	•		•			• ₁₃	• ₁₃	• ₁	• ₁	•	• _{2,12,15}	• ₈	• ₈		• ₃	•	•
MG3694C	•	•		•			• ₁₃	• ₁₃	• ₁	• ₁	•	• _{2,12,15}	• ₈	• ₈		• ₃	•	•
MG3695C	•	•			•		• ₁₃	• ₁₃	• ₁	• ₁	•		• ₈		• ₈	• ₃	•	•
MG3697C	•	•			•		• ₁₃	• ₁₃	• ₁	• ₁	•		• ₈		• ₈	• ₃	•	•

MODELS	OPTIONS														OPT 36	OPT 98	OPT 99
	OPT 15				OPT 16	OPT 17	OPT 18	OPT 20	OPT 22	OPT 26		OPT 27	OPT 28				
	15A	15B	15C	15D						26A	26B		28A	28B			
MG3691C	• ₁₂				•	• ₁₀	• _{2,12,16}	• _{9,16}	• _{5,11}	•		• ₆	• ₇		• _{14,15,16}	•	•
MG3692C	• ₁₂				•	• ₁₀	• _{2,12,16}	• _{9,16}	• ₅	•		• ₆	• ₇		• _{14,15,16}	•	•
MG3693C		• ₁₂			•	• ₁₀	• _{2,12,16}		• ₅	•		• ₆	• ₇		• _{14,15,16}	•	•
MG3694C		• ₁₂			•	• ₁₀	• _{2,12,16}		• ₅		•	• ₆		• ₇	• _{14,15,16}	•	•
MG3695C			• ₁₂		•	• ₁₀	• _{12,16}		• ₅		•	• ₆		• ₇	• _{14,15,16}	•	•
MG3697C				• ₁₂	•	• ₁₀	• ₁₆		• ₅		•	• ₆		• ₇	• _{14,15,16}	•	•

Footnote 1 Options 4 and 5 CAN NOT be ordered together

Footnote 2 Options 7 and 18 CAN NOT be ordered together
Options 7 and 20 CAN NOT be ordered together

Footnote 3 Option 10 CAN ONLY be ordered with either Options 27 or 28

Footnote 5 Option 22 CAN ONLY be ordered with either Options 4 or 5
Option 22 CAN NOT be ordered with Option 20

Footnote 6 Option 27 CAN ONLY be ordered with either Options 12, 14 or 26
(in any combination)

Footnote 7 Option 28 CAN NOT be ordered along with either Options 12, 14, 26, or 27

Footnote 8 Option 8 CAN NOT be ordered along with Option 9

Footnote 9 Option 20 CAN NOT be ordered with Option 2E, Option 7,
Option 15 or Option 22

Footnote 10 Option 17 CAN ONLY be ordered with either Option 1A or 1B

Footnote 11 Option 2E CAN NOT be ordered with Option 22

Footnote 12 Option 18 CAN NOT be ordered with Option 15 or 7,
Option 15 CAN NOT be ordered with Option 20

Footnote 13 Option 3 CAN NOT be ordered with Option 3X and visa versa.

Footnote 14 Option 36 CAN ONLY be ordered with either Option 3 or 3X

Footnote 15 Option 7 and 36 CAN NOT be ordered together

Footnote 16 Option 36 CAN be ordered with EITHER option 18 or 20,
but CAN NOT be ordered with both

Training at Anritsu

Anritsu has designed courses to help you stay up to date with technologies important to your job.

For available training courses visit: www.anritsu.com/training

Anritsu

Anritsu Corporation

5-1-1 Onna, Atsugi-shi, Kanagawa, 243-8555 Japan
Phone: +81-46-223-1111
Fax: +81-46-296-1238

• U.S.A.

Anritsu Company

1155 East Collins Boulevard, Suite 100,
Richardson, TX, 75081 U.S.A.
Toll Free: 1-800-ANRITSU (267-4878)
Phone: +1-972-644-1777
Fax: +1-972-671-1877

• Canada

Anritsu Electronics Ltda.

700 Silver Seven Road, Suite 120, Kanata,
Ontario K2V 1C3, Canada
Phone: +1-613-591-2003
Fax: +1-613-591-1006

• Brazil

Anritsu Eletrônica Ltda.

Praça Amadeu Amaral, 27 - 1 Andar
01327-010 - Bela Vista - São Paulo - SP - Brasil
Phone: +55-11-3283-2511
Fax: +55-11-3288-6940

• Mexico

Anritsu Company, S.A. de C.V.

Av. Ejército Nacional No. 579 Piso 9, Col. Granada
11520 México, D.F., México
Phone: +52-55-1101-2370
Fax: +52-55-5254-3147

• U.K.

Anritsu EMEA Ltd.

200 Capability Green, Luton, Bedfordshire LU1 3LU, U.K.
Phone: +44-1582-433280
Fax: +44-1582-731303

• France

Anritsu S.A.

12 Avenue du Québec,
Bâtiment Iris 1-Silic 638,
91140 VILLEBON SUR YVETTE, France
Phone: +33-1-60-92-15-50
Fax: +33-1-64-46-10-65

• Germany

Anritsu GmbH

Nemetschek Haus, Konrad-Zuse-Platz 1
81829 München, Germany
Phone: +49 (0) 89 442308-0
Fax: +49 (0) 89 442308-55

• Italy

Anritsu S.p.A.

Via Elio Vittorini, 129, 00144 Roma, Italy
Phone: +39-06-509-9711
Fax: +39-06-502-2425

• Sweden

Anritsu AB

Borgafjordsgatan 13, 164 40 KISTA, Sweden
Phone: +46-8-534-707-00
Fax: +46-8-534-707-30

• Finland

Anritsu AB

Teknobulevardi 3-5, FI-01530 VANTAA, Finland
Phone: +358-20-741-8100
Fax: +358-20-741-8111

• Denmark

Anritsu A/S (for Service Assurance)

Anritsu AB (for Test & Measurement)

Kirkebjerg Allé 90 DK-2605 Brøndby, Denmark
Phone: +45-7211-2200
Fax: +45-7211-2210

• Russia

Anritsu EMEA Ltd.

Representation Office in Russia

Tverskaya str. 16/2, bld. 1, 7th floor.
Russia, 125009, Moscow
Phone: +7-495-363-1694
Fax: +7-495-935-8962

• United Arab Emirates

Anritsu EMEA Ltd.

Dubai Liaison Office

P O Box 500413 - Dubai Internet City
Al Thuraya Building, Tower 1, Suite 701, 7th Floor
Dubai, United Arab Emirates
Phone: +971-4-3670352
Fax: +971-4-3688460

• Singapore

Anritsu Pte. Ltd.

60 Alexandra Terrace, #02-08, The Comtech (Lobby A)
Singapore 118502
Phone: +65-6282-2400
Fax: +65-6282-2533

• India

Anritsu Pte. Ltd.

India Branch Office

3rd Floor, Shri Lakshminarayan Niwas, #2726, 80 ft Road,
HAL 3rd Stage, Bangalore - 560 075, India
Phone: +91-80-4058-1300
Fax: +91-80-4058-1301

• P. R. China (Hong Kong)

Anritsu Company Ltd.

Units 4 & 5, 28th Floor, Greenfield Tower, Concordia Plaza,
No. 1 Science Museum Road, Tsim Sha Tsui East,
Kowloon, Hong Kong, P.R. China
Phone: +852-2301-4980
Fax: +852-2301-3545

• P. R. China (Beijing)

Anritsu Company Ltd.

Beijing Representative Office

Room 2008, Beijing Fortune Building,
No. 5, Dong-San-Huan Bei Road,
Chao-Yang District, Beijing 100004, P.R. China
Phone: +86-10-6590-9230
Fax: +86-10-6590-9235

• Korea

Anritsu Corporation, Ltd.

8F Hyunjuk Bldg, 832-41, Yeoksam-Dong,
Kangnam-ku, Seoul, 135-080, Korea
Phone: +82-2-553-6603
Fax: +82-2-553-6604

• Australia

Anritsu Pty Ltd.

Unit 21/270 Ferntree Gully Road, Notting Hill
Victoria, 3168, Australia
Phone: +61-3-9558-8177
Fax: +61-3-9558-8255

• Taiwan

Anritsu Company Inc.

7F, No. 316, Sec. 1, Neihu Rd., Taipei 114, Taiwan
Phone: +886-2-8751-1816
Fax: +886-2-8751-1817