



Advanced Test Equipment Rentals
www.atecorp.com 800-404-ATEC (2832)

5200A

AC Calibrator

Instruction Manual

P/N 357194
September 1975 Rev. 3 5/85
©1985 John Fluke Mfg. Co., Inc.
All rights reserved. Litho in U.S.A.



CHANGE/ERRATA INFORMATION

ISSUE NO: 4 12/92

This change/errata contains information necessary to ensure the accuracy of the following manual. Enter the corrections in the manual if either one of the following conditions exist:

1. The revision letter stamped on the indicated PCB is equal to or higher than that given with each change.
2. No revision letter is indicated at the beginning of the change/errata.

MANUAL

Title: 5200A
Print Date: September 1975
Rev.- Date: 3, 5/85

C/E PAGE EFFECTIVITY

Page No.	Print Date
1	7/89
2	7/89
3	7/89
4	7/89
5	7/89
6	7/89
7	7/89
8	7/89
9	7/89
10	7/89
11	7/89
12	7/89
13	7/89
14	7/89
15	7/89
16	7/89
17	7/89
18	7/89
19	7/89
20	7/89
21	7/89
22	7/89
23	7/89
24	7/89
25	7/89
26	12/92

ERRATA #3

At the top of page 1-3,

CHANGE: ACCURACY
 (for 90 days, 23 +-5°C, after
 1-hour warmup.)

TO: ACCURACY
 (for 180 days, 23 +-5°C, after
 1-hour warmup.)

ERRATA #5

On page 1-3, replace the following,

FROM:

SHORT TERM AMPLITUDE STABILITY

1-mV to 100V Ranges:

The change in rms value will be less than
 (0.007% of setting + 0.0003% of range)
 p-p for the 1 kHz thru 1 MHz ranges and
 (0.007% of setting + 0.004% of range)
 p-p for the 100 Hz range over a ten
 minute interval.

LONG TERM AMPLITUDE STABILITY

(At Constant Line, Load and Temperature)

±0.005% of setting for 24 hours

±0.01% of setting for 6 months

TO:

Stability:

Voltage Ranges	Frequency Hz	Stability ⁴ (ppm setting + ppm range) ⁵	
		10 Minutes	180 Days
1 mV 10 mV	10 - 30	70 + 40	300 + 60
	30 - 20k	70 + 3	100 + 30
	20k - 100k	70 + 3	130 + 40
100 mV	10 - 30	70 + 40	300 + 60
	30 - 1k	70 + 3	70 + 40
	1k - 20k	70 + 3	100 + 30
	20k - 50k	70 + 3	120 + 50
	50k - 100k	70 + 3	100 + 130
1 V 10 V 100 V	10 - 30	70 + 40	200 + 20
	30 - 20k	35 + 5	45 + 5
	20k - 50k	55 + 5	65 + 5
	50k - 100k	70 + 3	220 + 20
1000 V ⁶	10 - 30	100 + 20	200 + 20
	30 - 100	35 + 5	60 + 10
	100 - 10k	35 + 5	60 + 10
	10k - 20k	35 + 5	70 + 10
	20k - 50k	70 + 5	110 + 10
50k - 100k	70 + 5	350 + 50	

Notes: 4. Output is through 5205A or 5215A amplifier.
 5. Constant line, load, and temperature.
 6. Total peak to peak random change in rms value.

TTL compatible, or contact closures to ground. Connection of the programming control lines to the Remote Control Unit is by means of a card-edge connector accessed through an opening in the rear panel of the 5200A.

1-9. The 5200A may be bench or 19 inch rack mount-

ed. (The overall dimensions of the unit are shown in Figure 1-1.) Input power requirements are 100, 115, 200, or 230V ac ± 10 percent, 50 to 60 Hz, 150VA. A 50-to-400 Hz Input Power Modification (-02 option) is available to permit the unit to operate from 400 Hz, as well as 50- and 60- Hz, power lines.

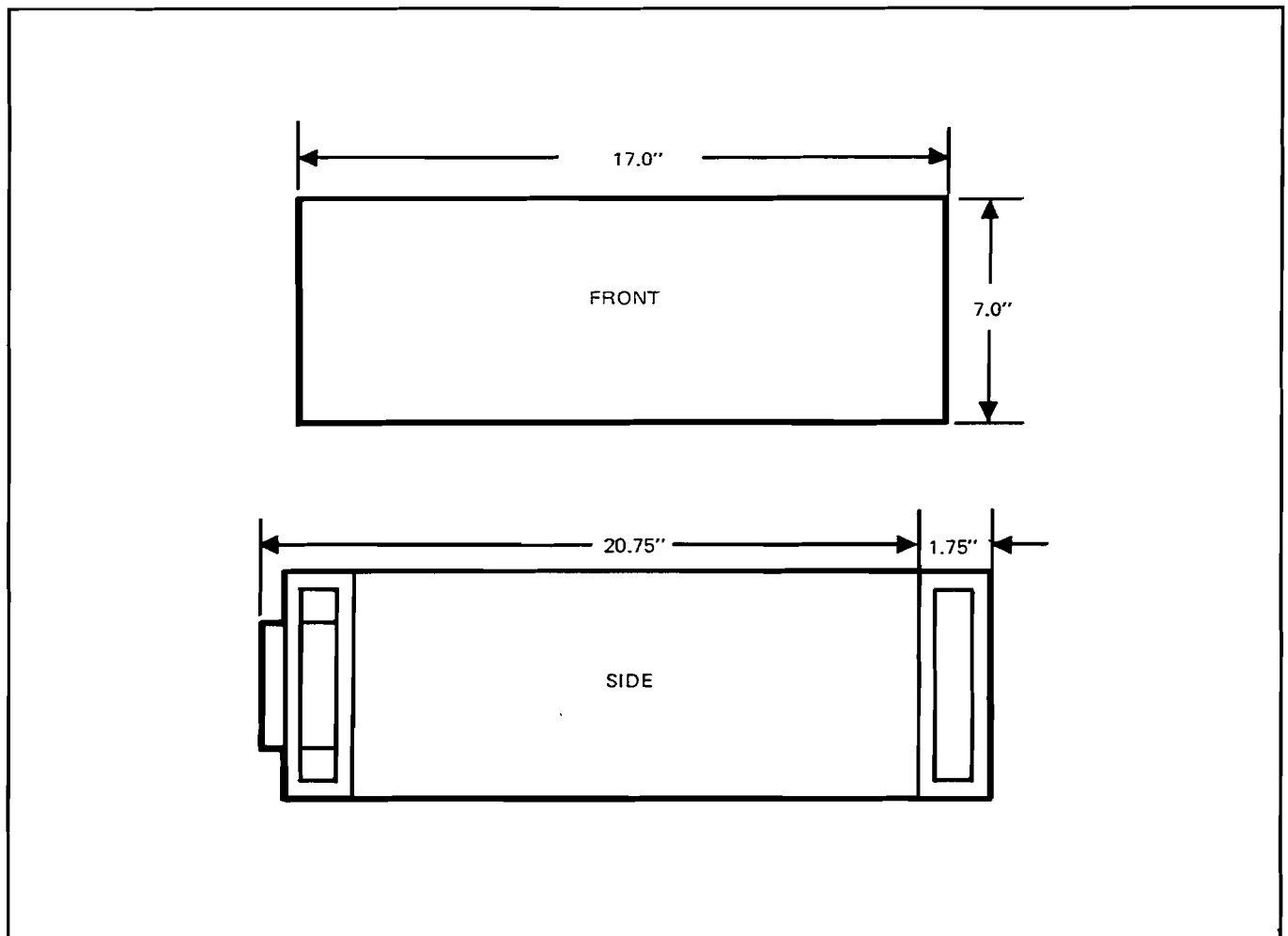

Figure 1-1. EQUIPMENT DIMENSIONS

1-10. SPECIFICATIONS

VOLTAGE RANGES

1 mV, 10 mV, 100 mV, 1V, 10V, 100V
(1000V with 5205A Power Amplifier)

Overrange

20% on all ranges (120V maximum)
(1100V with 5205A Power Amplifier)

Range Limits

10% to 120% (100 μ V and above)

Resolution

0.0001% of Range (1 nV on 1-mV range)

FREQUENCY RANGES

100 Hz, 1 kHz, 10 kHz, 100 kHz, 1 MHz

Overrange

20% on all ranges (1.2 MHz maximum)

Range Limits

10% to 120% (10 Hz and above)

Resolution

0.01% of Range (.01 Hz on 100-Hz Range)

$\pm 0.1\%$ of Range (100 kHz Range)

$\pm 1.0\%$ of Range (1MHz Range)

ACCURACY

(for 90 days, 23 ±5°C, after 1-hour warmup.)

Amplitude

10 Hz to 30 Hz

± (0.1% of setting +0.005% of range)
1, 10, 100 volt ranges.

± (0.1% of setting +10 μV)
1, 10, 100 millivolt ranges.

30 Hz to 20 kHz

± (0.02% of setting +0.002% of range)
1, 10, 100 volt ranges.

± (0.02% of setting +10 μV)
1, 10, 100 millivolt ranges.

20 kHz to 100 kHz

± (0.05% of setting +0.005% of range)
1, 10, 100 volt ranges

± (0.05% of setting +20 μV)
1, 10, 100 millivolt ranges.

0.1 MHz to 1 MHz¹

± (0.33% of setting +0.03% of range)
1, 10, 100 volt ranges.

± (0.33% of setting +30 μV)
1, 10, 100 millivolt ranges.

Frequency

100-Hz to 100-kHz Ranges ±(1% of setting
+0.1% of range)

1-MHz Range ±(3% of setting
+0.3% of range)

SHORT TERM AMPLITUDE STABILITY

1-mV to 100V Ranges:

The change in rms value will be less than (0.007% of setting + 0.0003% of range) p-p for the 1 kHz thru 1 MHz ranges and (0.007% of setting + 0.004% of range) p-p for the 100 Hz range over a ten minute interval.

LONG TERM AMPLITUDE STABILITY
(At Constant Line, Load and Temperature)

±0.005% of setting for 24 hours

±0.01% of setting for 6 months

FREQUENCY STABILITY

±0.05% for 24 hours

±0.1% for 6 months

¹ NOTE: on 1mV range, at output frequencies above 100 kHz, specifications apply for measuring instruments with bandwidths less than 2 MHz.

AMPLITUDE LIMITS WITH TEMPERATURE

(0° to 18°C and 28°C to 50°C)

Add ±(0.025 x accuracy) per °C to stated accuracy limits

FREQUENCY LIMITS WITH TEMPERATURE

(0° to 18°C and 28°C to 50°C)

Add ±(0.025 of setting) per °C to stated accuracy limits

MAXIMUM OUTPUT CURRENT (For Rated Accuracy)

50 mA rms from 10% to 120% of range

NOTE: Min. Load impedance for specified accuracy:

1-, 10-, 100-mV Ranges	6kΩ
1V Range	50Ω above .1 MHz

CURRENT LIMIT

The output is protected against overloads and short circuits by a current limiter.* Upon removal of the overload, the output will recover automatically.

*NOTE: See MAX. INDUCTIVE LOAD.

MAXIMUM CAPACITIVE LOAD

1000 pF

MAXIMUM INDUCTIVE LOAD

Maximum inductive current allowed is shown below.

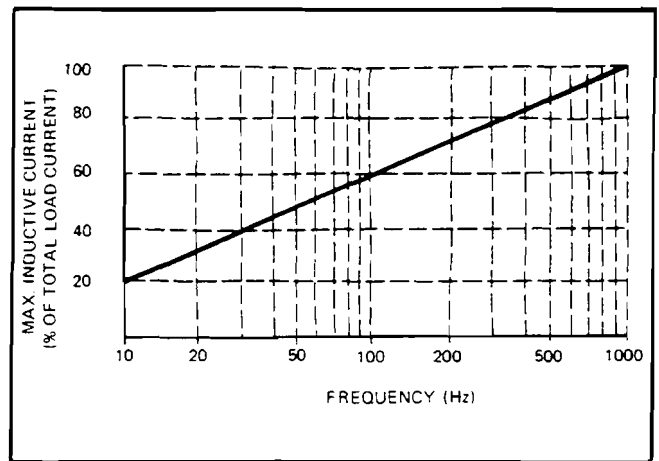

The above limit does not restrict the use of precision inductive dividers that have a maximum voltage limit of (0.35 x frequency) or higher.

MAXIMUM OUTPUT VOLTAGE

120V rms, up to 83.33 kHz. Beyond that, maximum output voltage decreases as frequency increases. At highest frequency (1.2 MHz), maximum output voltage is 8.33V rms. Maximum volt-hertz product is 1.0×10^7 or $1.0 \times 10^7 \times (\text{Voltage Range}/10)$, whichever is less (See graph below).

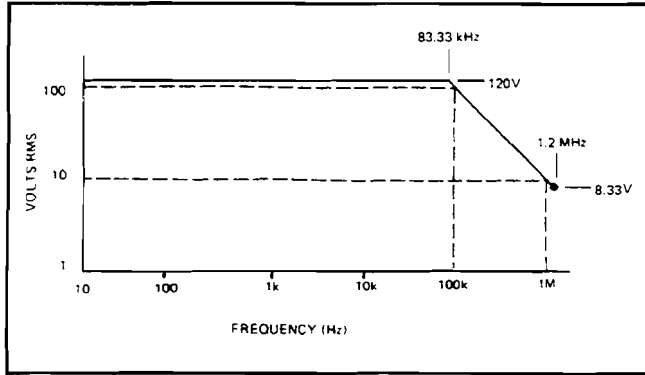

RESPONSE TIME

For any programmed amplitude, the output voltage and frequency will settle to within 0.01% of change as follows:

10 Hz - 30 Hz	4 to 15 seconds
30 Hz - 100 Hz	4 seconds
100 Hz - 400 Hz	2 seconds
400 Hz - 1 MHz	1 second*

The output will recover from short circuits and overload conditions within the specified settling time.

*Typically below 0.5 seconds from 400 Hz to 1.2 MHz except for frequency range changes.

TOTAL HARMONIC DISTORTION AND LINE RELATED NOISE

(Bandwidth 10 Hz to 10 MHz) Effects of broadband noise included in accuracy specification for both RMS and average responding instruments.

10 Hz to 100 kHz . . .	0.04% of setting +10 μ V rms *†
100 kHz to 500 kHz . . .	0.3% of setting +30 μ V rms
500 kHz to 1 MHz . . .	1% of setting +30 μ V rms

*For output currents exceeding 15 mA, see below:

†The specification on the 1-Volt range between 10 Hz and 15 Hz is 0.08% of setting + 10uV rms.

20 kHz to 100 kHz

$$\left[0.04 + \left(\frac{0.3}{V} \right) \left(\frac{F}{100} \right) \left(\frac{I}{50} \right)^2 \right] \%$$

V = volts, F = kHz, I = mA

LOAD REGULATION (EXT. SENSE MODE)

0.005% of selected range, no load to full load, up to 10 kHz. Beyond that, regulation is a function of both range and frequency selected (See following graph).

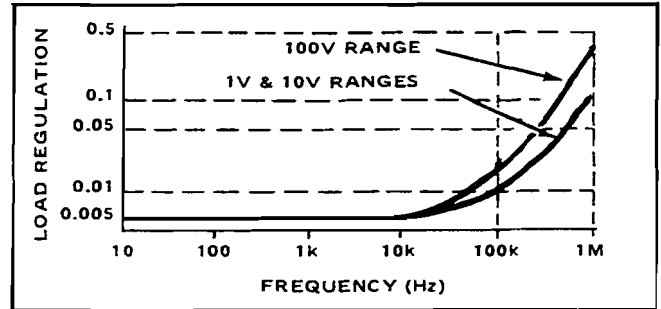

NOTE: Output impedance on the 1-mV through 100-mV ranges in less than 1.5 Ω in series with 1.5 μ H.

LINE REGULATION

$\pm 0.001\%$ of setting for a 10% change in line voltage.

EXTERNAL FREQUENCY PHASE LOCK INPUT

The oscillator of the 5200A has the capability of being phased locked to an external signal. Phase lock accuracy is $\pm 3^\circ$ below 30 Hz, and $\pm (1^\circ + 0.05^\circ \text{ per kHz})$ over a $\pm 2\%$ band around the center frequency, (BNC connector on rear panel). Input is 1 volt to 10 volts rms (useable down to 100mV rms).

QUADRATURE OUTPUT

(Minimum Load Z = 3 k Ω)

Amplitude

10V rms $\pm 10\%$ when 100% of range is selected. Quadrature amplitude is proportional to the dialed output voltage from 10% to 100% of Range. (BNC connector on rear panel.)

Phase

$90^\circ \pm (1^\circ + 0.03^\circ \text{ per kHz})$, 40 Hz to 1.2 MHz.

$90^\circ \pm 3^\circ$, 10 Hz to 40 Hz

COUNTER OUTPUT

Auxiliary frequency counter output (BNC Connector) on rear panel; 3V pulse, short circuit protected.

EXTERNAL SENSE

A two position switch is provided to control Internal or External Sensing on the 1V, 10V, and 100V ranges. When in Remote Sense (1, 10 and 100V ranges) and the sense leads are accidentally disconnected, the output voltage will not exceed the programmed setting by more than 2.0 volts.

VOLTAGE ERROR MEASUREMENT

0 to $\pm 0.3\%$ with 0.001% resolution

0 to $\pm 3\%$ with 0.01% resolution

An "OFF" error switch position is provided to easily lock out the error measurement function which is automatically disabled in program mode.

OUTPUT TERMINALS

High, Low, High Sense, Low Sense, Guard, and Ground terminals on front and rear panels. Front panel terminals are five-way binding post. Rear panel terminals are pins of a pcb card-edge connector, with mating connector supplied (P/N 337675).

LOCAL/REMOTE OPERATION

Two-position CONTROL switch, interlocked with the optional remote programming function. In the LOCAL position, all control is implemented from the front panel switches. In the REM position, control is obtained via the programming lines through a rear panel connector. When the REMOTE function is called on the programming line, the 5200A will be locked in the Remote condition (regardless of the position of the CONTROL switch), disabling the error measurement control and all other front panel controls except the POWER switch. When the LOCAL function is called on the programming line, the 5200A may be operated in either the Local or the Remote condition, at the operator's discretion.

SAFETY FEATURES

When the ac power is turned on, the instrument is automatically set to the Standby condition. When in Remote Sense and the sense leads are accidentally disconnected, the output voltage will not exceed 2.0 volts above the programmed setting on the 1V thru 100V ranges. The 1 mV thru 100 mV ranges are not affected.

CALIBRATION REQUIREMENTS

The 5200A is calibrated at the factory by instrumentation traceable to the National Bureau of Standards. Periodic calibration of the 1V, 10V, and 100V ranges may be accom-

plished through the use of a thermal transfer standard and a precision dc source, such as the Fluke Models 540B and 332D. The accuracy on the 1-, 10-, and 100 mV ranges depends on precision inductive dividers which are tested at the factory with special verification equipment, and do not require periodic adjustment. All other adjustments can be made with general purpose laboratory equipment.

GENERAL

Input Power

100, 115, 200, 230V ac $\pm 10\%$ (switch selectable), 50 to 60 Hz (50-to-400-Hz Option available, 150 VA).

Maximum Isolation Voltages

500V dc or peak ac, "Guard" to "Chassis"

100V dc or peak ac, "Lo" to "Guard"

Dimensions

7" (178 mm) x 17" (432 mm) x 21.75" (533 mm)

Weight

53 pounds (24 kg)

ENVIRONMENTAL

Cooling

Forced air cooled. Air intake through re-useable filter on rear panel. Air exit along both sides.

Temperature

0°C to 50°C, operating
-40°C to +75°C, storage

Relative Humidity

0 to 80 percent (0°C to +40°C)
0 to 70 percent (+40°C to +50°C)

Shock

15G, 11-ms half-sine wave

Vibration

3.1G, 10 Hz to 55 Hz

Altitude

0 to 10,000 feet, operating
50,000 feet, non-operating

Protection Class 1 (relates solely to insulation and grounding properties further defined in IEC 348.)