

Vaisala HMP230 series humidity transmitters

Output quantities:	Relative humidity (%), temperature (C°/F°) dewpoint temperature (°C/°F), mixing ratio (g/kg) / (gr/lb), absolute humidity (g/m ³) / (gr/ft ³), wet bulb temperature (°C/°F), enthalpy (kJ/kg) / (Btu/lb)
Operating voltage:	24 VDC/VAC, with optional power supply module 230/115 VAC
Two analog outputs: (channels 1 & 2)	0...20 mA / 4...20 mA / 0...1 V / 0...5 V / 0...10 V
Serial connections:	RS232C interface, RS485/422 module, current loop module
Screw terminals:	0.5 mm ² ...1.5 mm ² wires (AWG 20...16)

Wiring diagram

MAIN BOARD

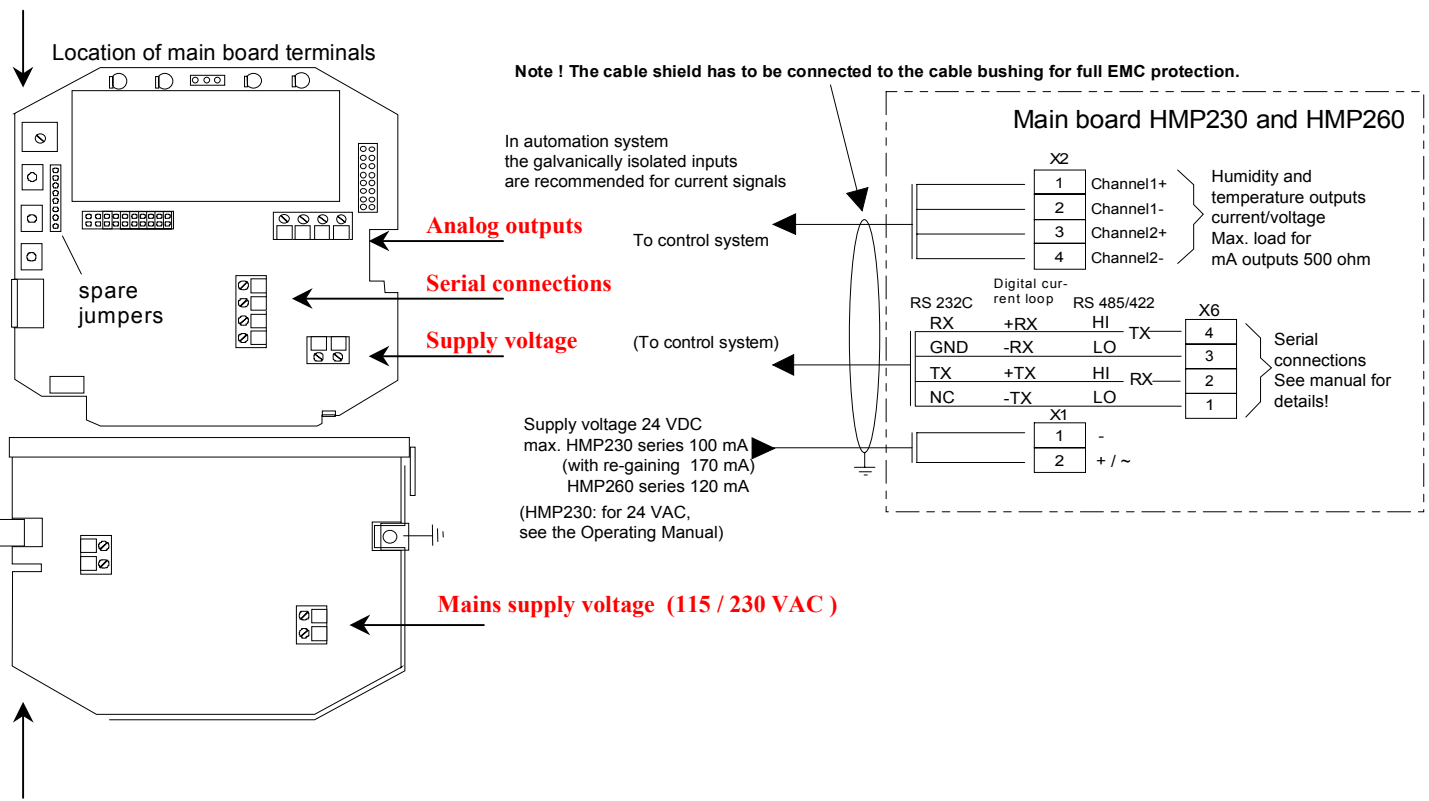

POWER SUPPLY MODULE (optional)