



Advanced Test Equipment Rentals
www.atecorp.com 800-404-ATEC (2832)



**TERMALINE[®] SEMICONDUCTOR
LOAD RESISTOR
SERIES 8860S**

SAFETY PRECAUTIONS

The following are general safety precautions that are not necessarily related to any specific part or procedure, and do not necessarily appear elsewhere in this publication. These precautions must be thoroughly understood and apply to all phases of operation and maintenance.

WARNING

Keep Away From Live Circuits

Operating Personnel must at all times observe general safety precautions. Do not replace components or make adjustments to the inside of the test equipment with the high voltage supply turned on. To avoid casualties, always remove power.

WARNING

Shock Hazard

Do not attempt to remove the RF transmission line while RF power is present.

WARNING

Do Not Service Or Adjust Alone

Under no circumstances should any person reach into an enclosure for the purpose of service or adjustment of equipment except in the presence of someone who is capable of rendering aid.

WARNING

Safety Earth Ground

An uninterruptible earth safety ground must be supplied from the main power source to test instruments. Grounding one conductor of a two conductor power cable is not sufficient protection. Serious injury or death can occur if this grounding is not properly supplied.

WARNING

Resuscitation

Personnel working with or near high voltages should be familiar with modern methods of resuscitation.

WARNING

Remove Power

Observe general safety precautions. Do not open the instrument with the power on.

SAFETY SYMBOLS

WARNING

Warning notes call attention to a procedure, which if not correctly performed, could result in personal injury.

CAUTION

Caution notes call attention to a procedure, which if not correctly performed, could result in damage to the instrument.



This symbol indicates that a shock hazard exists if the precautions in the instruction manual are not followed.



The caution symbol appears on the equipment indicating there is important information in the instruction manual regarding that particular area.



This symbol indicates that the unit radiates heat and should not be touched while hot.

Note: *Calls attention to supplemental information.*

WARNING STATEMENTS

The following safety warnings appear in the text where there is danger to operating and maintenance personnel, and are repeated here for emphasis.

WARNING

The vent plug must be used at all times when the unit is operating or cooling. Failure to do so could result in an explosion or severe burns.

On page 5 and 6.

WARNING

Never attempt to connect or disconnect RF equipment from the transmission line while RF power is being applied. Leaking RF energy is a potential health hazard.

On page 7, 9, 11 and 12.

WARNING

Disconnect the unit from all power sources before servicing. The unit may be energized from multiple sources. The potential for electric shock exists.

On page 11 and 13.

CAUTION STATEMENTS

The following equipment cautions appear in the text and are repeated here for emphasis.

CAUTION
This load is designed for operation in a horizontal position only, with the vent plug up. Do not use in any other manner.

On page 5.

CAUTION
Do not contaminate the coolant with pipe sealant.

On page 6.

CAUTION
If installed, connect optional interlock before applying RF power.

On page 6.

CAUTION
Use only Bird coolant, P/N 5-1070, to prevent damage to the load.

On page 13.

SAFETY STATEMENTS

USAGE

ANY USE OF THIS INSTRUMENT IN A MANNER NOT SPECIFIED BY THE MANUFACTURER MAY IMPAIR THE INSTRUMENT'S SAFETY PROTECTION.

USO

EL USO DE ESTE INSTRUMENTO DE MANERA NO ESPECIFICADA POR EL FABRICANTE, PUEDE ANULAR LA PROTECCIÓN DE SEGURIDAD DEL INSTRUMENTO.

BENUTZUNG

WIRD DAS GERÄT AUF ANDERE WEISE VERWENDET ALS VOM HERSTELLER BESCHRIEBEN, KANN DIE GERÄTESICHERHEIT BEEINTRÄCHTIGT WERDEN.

UTILISATION

TOUTE UTILISATION DE CET INSTRUMENT QUI N'EST PAS EXPLICITEMENT PRÉVUE PAR LE FABRICANT PEUT ENDOMMAGER LE DISPOSITIF DE PROTECTION DE L'INSTRUMENT.

IMPIEGO

QUALORA QUESTO STRUMENTO VENISSE UTILIZZATO IN MODO DIVERSO DA COME SPECIFICATO DAL PRODUTTORE LA PROIZIONE DI SICUREZZA POTREBBE VENIRNE COMPROMESSA.

SERVICE

SERVICING INSTRUCTIONS ARE FOR USE BY SERVICE - TRAINED PERSONNEL ONLY. TO AVOID DANGEROUS ELECTRIC SHOCK, DO NOT PERFORM ANY SERVICING UNLESS QUALIFIED TO DO SO.

SERVICIO

LAS INSTRUCCIONES DE SERVICIO SON PARA USO EXCLUSIVO DEL PERSONAL DE SERVICIO CAPACITADO. PARA EVITAR EL PELIGRO DE DESCARGAS ELÉCTRICAS, NO REALICE NINGÚN SERVICIO A MENOS QUE ESTÉ CAPACITADO PARA HACERLO.

WARTUNG

ANWEISUNGEN FÜR DIE WARTUNG DES GERÄTES GELTEN NUR FÜR GESCHULTES FACHPERSONAL.

ZUR VERMEIDUNG GEFÄHRLICHER, ELEKTRISCHER SCHOCKS, SIND WARTUNGSARBEITEN AUSSCHLIEßLICH VON QUALIFIZIERTEM SERVICEPERSONAL DURCHZUFÜHREN.

ENTRETIEN

L'EMPLOI DES INSTRUCTIONS D'ENTRETIEN DOIT ÊTRE RÉSERVÉ AU PERSONNEL FORMÉ AUX OPÉRATIONS D'ENTRETIEN. POUR PRÉVENIR UN CHOC ÉLECTRIQUE DANGEREUX, NE PAS EFFECTUER D'ENTRETIEN SI L'ON N'A PAS ÉTÉ QUALIFIÉ POUR CE FAIRE.

ASSISTENZA TECNICA

LE ISTRUZIONI RELATIVE ALL'ASSISTENZA SONO PREVISTE ESCLUSIVAMENTE PER IL PERSONALE OPPORTUNAMENTE ADDESTRATO. PER EVITARE PERICOLOSE SCOSSE ELETTRICHE NON EFFETTUARE ALCUNA RIPARAZIONE A MENO CHE QUALIFICATI A FARLA.

CONNECT INTERLOCK TO TRANSMITTER BEFORE OPERATING.

BRANCHER LE VERROUILLAGE À L'ÉMETTEUR AVANT EMPLOI.

CONECTE EL INTERBLOQUEO AL TRANSMISOR ANTES DE LA OPERACION.

VOR INBETRIEBNAHME VERRIEGELUNG AM SENDER ANSCHLIESSEN.

**PRIMA DI METTERE IN FUNZIONE L'APPARECCHIO, COLLEGARE IL
DISPOSITIVO DI BLOCCO AL TRASMETTITORE.**

ABOUT THIS MANUAL

This manual covers the operating and maintenance instructions for the following models:

8865SC13

CHANGES TO THIS MANUAL

We have made every effort to ensure this manual is accurate. If you discover any errors, or if you have suggestions for improving this manual, please send your comments to our Solon, Ohio factory. This manual may be periodically updated. When inquiring about updates to this manual refer to the part number and revision on the title page.

CHAPTER LAYOUT

Introduction - Describes the features of the Bird Termaline, Semiconductor, RF Load Resistor lists equipment supplied and optional equipment, and provides power-up instructions.

Theory of Operation - Describes how the Termaline, Semiconductor, RF Load Resistor works and its functions.

Installation - Describes the how to install the Termaline, Semiconductor, RF Load Resistor.

Operation with Blower - Describes procedures require for operating the load resistor equipped with a blower unit.

Maintenance — Lists routine maintenance tasks as well as troubleshooting for common problems. Specifications and parts information are also included.

TABLE OF CONTENTS

Safety Precautions	i
Safety Symbols	i
Warning Statements	ii
Caution Statements	iii
Safety Statements	iv
About This Manual	vii
Changes to this Manual	vii
Chapter Layout	vii
Chapter 1 Introduction	1
Items Supplied	1
Items Required but not Supplied	1
Optional Accessories	1
Chapter 2 Theory of Operation	3
Load Resistor	3
Coolant	3
Thermal Interlock	3
Chapter 3 Installation	5
Unpacking and Inspection	5
Setup	5
Mounting	5
Installing Thermoswitch	6
Interlock Connection	6
Connecting RF Power	7
“QC” Connector Coupling	7
Chapter 4 Operating Instructions	9
Normal Operation	9
Operation Under Abnormal Conditions	9
Shutdown	9
Emergency Shutdown	9
Chapter 5 Maintenance	11
Troubleshooting	11
Maintenance	12
Cleaning	12
Inspection	12
DC Resistance	12
Coolant Level	13
Inspecting the Coolant	13
Repair	13
Replacing the RF Connector	13
Replacing the Load Resistor	14
Storage and Shipment	14
Storing the Load Resistor	14
Shipping the Load Resistor	14
Customer Service	15
Specifications	16
Replacement Parts	16
Available “QC” Type Connectors	17
Limited Warranty	18

Bird 8860 Series Semiconductor Loads are portable 50 ohm coaxial RF transmission line terminations. They are designed for frequency ranges of DC – 28 MHz, specially calibrated for greater stability at 13.56 MHz. They provide accurate, dependable, and low reflection line terminations. Up to 1000 watts of RF power can be dissipated.

The load has a coolant chamber surrounded by radiator fins. The front and rear fins form mounting flanges which can be used as supports for freestanding use or as brackets for fixed mounting. A vent plug at the top of the unit relieves internal pressure from coolant expansion. The load's simple and rugged design minimizes maintenance requirements.

Items Supplied

- Load Resistor: Pre-filled with coolant at the factory
- Shipping Plug
- Vent Plug
- Instruction Manual

Items Required but not Supplied

- **Coupling Kit:** Connects the load to the RF line

Optional Accessories

- **Interlock Thermoswitch:** Automatically shuts off the generator to prevent overheating of the load

Figure 1 Bird 8860 Series Outline Drawing

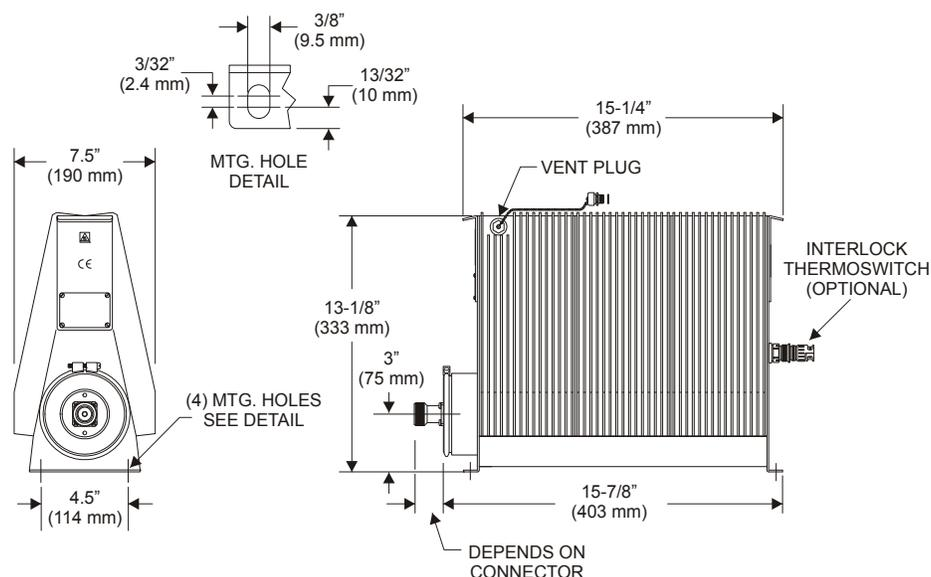

Load Resistor

Bird 8860 series loads consist of a thin-film-on-ceramic resistor immersed in a dielectric coolant. The resistor, individually selected for its accuracy, is enclosed in a special housing. When surrounded by the coolant, this produces a uniform, practically reflectionless line termination over the specified frequencies.

Coolant

The load is cooled by natural fluid and air convection currents. The coolant, chosen for its dielectric and thermal characteristics, carries heat from the resistor to the walls of the cooling tank, where radiator fins surrounding the tank transfer the heat to the air.

When the coolant is heated, thermal expansion causes an increase in the internal pressure. The vent plug relieves this pressure while protecting the opening from dirt or other contaminants.

Thermal Interlock

Loads can be supplied with an optional passive over-temperature thermostick. Normally closed, it opens at the maximum safe load temperature of 236 °C (457 °F), turning off power to the RF generator. The interlock system will not permit reoperation of the generator until the load has reached a lower, safe temperature.

Figure 2 Shipping Plug

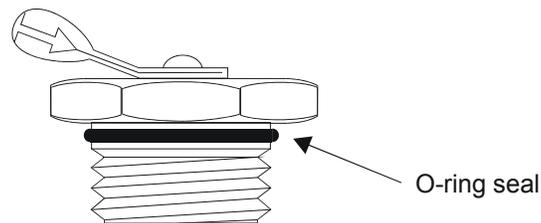
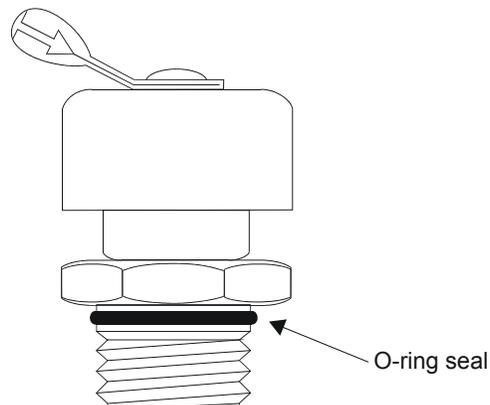

Figure 3 Vent Plug



This chapter provides information for on-site requirements, unpacking, inspection, and preparing the load for use.

Unpacking and Inspection

1. Carefully inspect shipping container for signs of damage.
2. Do one of the following:
 - If the shipping container is damaged, do not unpack the unit. Immediately notify the shipping carrier and Bird Electronic Corporation.
 - If the shipping container is not damaged, unpack the unit. Save shipping materials for repackaging.
3. Inspect unit for visual signs of damage.

Note: *If there is damage, immediately notify the shipping carrier and Bird Electronic Corporation.*

Setup

Note: *Before first using the load, get a resistance baseline for future maintenance. Refer to "DC Resistance" on page 12 for details.*

1. Remove the shipping plug from the load.
2. Replace the shipping plug with the vent plug. Refer to Figure 1 and Figure 2 for pictures of the plugs.

WARNING

The vent plug must be used at all times when the unit is operating or cooling. Failure to do so could result in an explosion or severe burns.

Mounting

Place the load in a dry, dust and vibration free environment. Do not use outdoors or in areas of condensing humidity. Allow at least 12" (30 cm) of clearance on all sides of the load.

CAUTION

This load is designed for operation in a horizontal position only, with the vent plug up. Do not use in any other manner.

These loads are equipped for either portable use or fixed installation. The mounting brackets on the front and rear faces have four mounting slots arranged in a $4\frac{1}{2}$ " x $14\frac{7}{32}$ " rectangle (114.3 x 361.2 mm). Use a screw with a $\frac{3}{8}$ " (9.53 mm) diameter max.

Installing Thermoswitch

Bird 8860 series loads can be equipped with an optional interlock thermoswitch, P/N 8890-008. It is normally closed, opening at 236 °C (457 °F), with a rating of 10A @ 120Vac and 5A @ 230Vac.

WARNING

The vent plug must be used at all times when the unit is operating or cooling. Failure to do so could result in an explosion or severe burns.

1. Remove the vent plug.
2. Install the shipping plug.
3. Stand the unit on its front, supporting it so that the connector is not damaged.

Note: *In this position there is no danger of the coolant pouring out through the socket plug hole.*

4. Remove the socket plug just above the connector assembly, using a $\frac{9}{16}$ " hex wrench.
5. Replace the plug with the thermoswitch.
6. Apply pipe sealing compound to the external threads of the thermoswitch sparingly, ONLY.

CAUTION

Do not contaminate the coolant with pipe sealant.

7. Check for coolant leaks upon completion.

Interlock Connection

CAUTION

If installed, connect optional interlock before applying RF power.

1. Unscrew the large knurled ring-nut (A) at the lower end of the coupling jack assembly.
2. Pull the large knurled ring-nut off the thermoswitch jack (B).
3. Unscrew the small knurled cover fitting from the base plug (D) of the connector to release the base.
4. Thread the control switch wires through the clamp (E) with the washers (F) inside and with its threaded fitting in place.
5. Service the control switch wire with short tips and put spaghetti sleeves over the wire ends if necessary.
6. Securely solder the control switch leads to the lugs (G) of the connector base.

Note: *The ring-nut (A) must be in place over the base plug (D) with the knurled end facing out.*

7. Screw on the cover ring, then fasten the cable clamp (E) in place and tighten both yoke screws (H).
8. Put the plug back on the thermoswitch and tighten the nut (A).

Figure 4 Thermoswitch Assembly

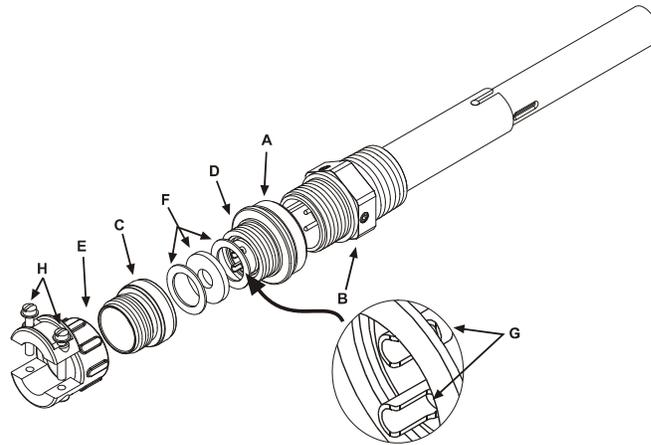

Connecting RF Power

After installing the load, the RF transmission line can be attached using standard coaxial line coupling kits.

WARNING

Never attempt to connect or disconnect RF equipment from the transmission line while RF power is being applied. Leaking RF energy is a potential health hazard.

“QC” Connector Coupling

Use 50 ohm coaxial cable such as RG-218/U or -220/U (-17A or -19A), appropriate for the frequency and power level of operation.

Use a cable connector which will mate with the one on the load.

Normal Operation

Bird 8860 series loads have no indicators or operating controls. They require no special operating procedures or surveillance when their performance limits are not exceeded. Follow the instructions for the specific generator equipment.

Operation Under Abnormal Conditions

The load can be subjected to moderate overloads for short periods. If this is likely, make sure the interlock is properly connected to prevent damage to the load.

Shutdown

These loads are passive devices, so have no way of being turned off. Turn off RF power at the source.

WARNING

Never attempt to connect or disconnect RF equipment from the transmission line while RF power is being applied. Leaking RF energy is a potential health hazard.

Emergency Shutdown

Turn off RF power at the source.

If the interlock thermoswitch is properly connected, RF power will be automatically turned off when the coolant temperature reaches an unsafe level.

This chapter covers cleaning, inspection, trouble-shooting, and specifications for the Bird 8860 series loads.

WARNING

Never attempt to connect or disconnect RF equipment from the transmission line while RF power is being applied. Leaking RF energy is a potential health hazard.

WARNING

Disconnect the unit from all power sources before servicing. The unit may be energized from multiple sources. The potential for electric shock exists.

Troubleshooting

The table below contains troubleshooting information for problems which can occur during normal operation. This manual cannot list all malfunctions that may occur, or their corrective actions. If a problem is not listed or is not corrected by the listed actions, notify a qualified service center.

PROBLEM	POSSIBLE CAUSE	CORRECTION
Overheating radiator	RF power too high	Lower RF power (See "Specifications" on page 16 for maximum RF power)
	Coolant level too low	Check the coolant level. Add coolant if necessary (See "Coolant Level" on page 13)
	Coolant degraded	Replace the coolant (See "Coolant Level" on page 13)
	Faulty resistor	Replace the resistor (See "Replacing the Load Resistor" on page 14)
Leaking coolant	Loose clamping band	Tighten the clamping band
	Defective or improperly installed O-ring	Replace the O-ring (See "Replacing the Load Resistor" on page 14)
High or low DC resistance	Loose RF input connector	Tighten connector
	Faulty RF input connector	Replace connector (See "Replacing the RF Connector" on page 13)
	Faulty resistor	Replace the resistor (See "Replacing the Load Resistor" on page 14)

Maintenance

Cleaning

- Wipe the load free of dust and dirt when necessary.

Note: *Excessive dust on the cooling fins will interfere with heat dissipation.*

- Clean the RF connector, both metallic and insulating surfaces, with a dry, non-residue forming solvent.

Inspection

- Inspect the unit every six months.
- Check for coolant leakage around the clamping band and the thermoswitch.
- Check for corrosion.

DC Resistance

Measuring the DC resistance between the inner and outer conductors of the RF connector shows changes in the load over time, a good check of the load resistor's condition. Under normal operating conditions, the resistor should provide at least 5,000 hours of operation before requiring any additional service. DC resistance tracking must start before the load is put into service, and should be measured annually.

Perform the following steps and record the value for future comparison. Make sure that you have an ohmmeter with an accuracy of $\pm 1\%$ at 50 ohms and that the load temperature is between 20 and 25 °C (68 to 77 °F) before starting.

Figure 5 Measuring Resistance

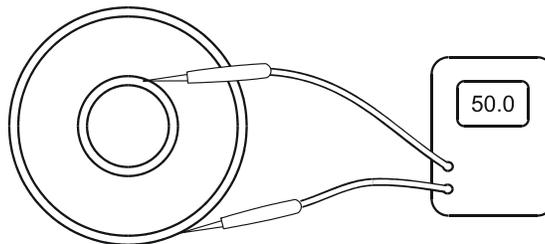

WARNING

Never attempt to connect or disconnect RF equipment from the transmission line while RF power is being applied. Leaking RF energy is a potential health hazard.

1. Turn off the RF power and interlock circuitry.
2. Disconnect the RF line.
3. Connect the multimeter test leads to the center and outer conductor of the load resistor (see Figure 5).
4. Compare the measured value with the previous measurement and with the baseline resistance, measured when the load was put into service.

Note: *If the new value differs from either of these by more than 1 ohm this could indicate a failing resistor.*

Coolant Level

Coolant lifetime will vary greatly depending on the operating temperature. For heavy use (full RF power for long times, high ambient temperature), check the coolant every 500 hours. If the load has only had light duty (fraction of full power, low temperature), then inspection may only be necessary every 2,000 hours.

WARNING

Disconnect the unit from all power sources before servicing. The unit may be energized from multiple sources. The potential for electric shock exists.

Note: *Correct any coolant leakage before inspection. (See "Troubleshooting" on page 11).*

Inspecting the Coolant

1. Remove the load resistor.
2. Inspect the coolant.
 - The coolant should be clear, with a faint yellow tinge, and have a slightly sweet smell. If it is black with a burnt or acrid smell, drain it and add about 2.9 gal (11 L) of coolant.
 - With the load still on end, the coolant level should be $3\frac{5}{8}$ " (92 mm) below the top surface of the resistor assembly mounting ring, at ambient temperature.
3. Add coolant if necessary.

CAUTION

Use only Bird coolant, P/N 5-1070, to prevent damage to the load.

Repair

WARNING

Disconnect the unit from all power sources before servicing. The unit may be energized from multiple sources. The potential for electric shock exists.

Replacing the RF Connector

The 8865SC13 has a Bird "QC" connector which allows easy changing of the RF connector. This does not disturb the coolant seal or affect the electrical continuity of the load. To change the connector:

1. Remove the four screws at the corners of the RF connector.
2. Pull the connector straight out.
3. Push the new connector in.

Note: *Make sure that the center pin on the connector is properly seated in the mating socket on the load.*

4. Replace the screws.

Note: *If not using the LC connector normally supplied, the frequency and power must be limited to the capabilities of the connector.*

Replacing the Load Resistor

1. Remove the vent plug and install the shipping plug.
2. Supporting the unit to prevent damage to the interlock, stand it on its back with the connector end up.

Note: *In this position there is no danger of the coolant pouring out through the resistor hole.*

3. Unscrew and remove the clamping band.
4. Lift the load resistor assembly out of the tank and allow any coolant to drip back into the tank.
5. The O-Ring should be free of twists and positioned evenly around the flange of the resistor housing.
Note: *If the O-ring shows signs of deterioration (e.g. is no longer pliable or has surface cracks) replace it.*
6. Replace the entire load resistor assembly.
Note: *It cannot be further disassembled.*
7. Put the clamping band in place and tighten it.
8. Remove the shipping plug and install the vent plug.

Storage and Shipment

Storing the Load Resistor

- Cover Bird 8890 Loads before storing to keep out dust and dirt.
- It is not necessary to install the shipping plug.
- Store in a dry, dust-free environment where the ambient temperature will remain between -40 and $+45$ °C (-40 to $+113$ °F).

Shipping the Load Resistor

1. Remove the vent plug.
2. Install the shipping plug.
3. Wrap the vent plug with padding and tape it to the side of the load for protection.
Note: *With the shipping plug installed, it is not necessary to empty out the coolant.*
4. Wrap the connector in padding.
5. Pack and brace the load in a sturdy wooden crate for shipment.

Customer Service

Any maintenance or service procedure beyond the scope of those in this chapter should be referred to a qualified service center.

If you need to return the unit for any reason, request an RMA through the Bird Technologies website (link shown below). All instruments returned must be shipped prepaid and to the attention of the RMA number.

Bird Service Center

30303 Aurora Road
Cleveland (Solon), Ohio 44139-2794
Fax: (440) 248-5426
E-mail: bsc@bird-technologies.com

For the location of the Sales Office nearest you, visit our website at:

<http://www.bird-technologies.com>

Specifications

Frequency Range	DC – 28 MHz
Power Rating	1000 W continuous duty
Impedance, Nominal	50 ohms
VSWR*	1.1 max
VSWR Stability	< 0.1 dB, from 0 to 100% rated power at stability frequency
Stability Frequency	13.56 MHz ± 10 kHz
Connector	“QC” Type, Female LC normally supplied
Interlock Thermoswitch (Optional)	Normally closed. Opens at 236 °C (457 °F)
Thermoswitch Rating 115 VAC 230 VAC	10 A 5 A
Temperature, Operating	+5 to +40 °C (+41 to +104 °F)
Temperature, Storage	–40 to +45 °C (–40 to +113 °F)
Altitude†	1520 m (5000 ft.)
Humidity	95% noncondensing max
Cooling method	Oil dielectric and convection currents
Dimensions	17.5" L x 7.5" W x 13 ¹ / ₈ " H (445 x 190 x 334 mm)
Weight, Nominal	27.8 lb. (12.6 kg)
Finish	Black Epoxy Resin

* VSWR measured using a female N connector.

† Derate RF power by 250 W for every 305m (1,000 ft.) above 1,520m (5,000 ft.)

Replacement Parts

Description	Qty	Part Number
RF Load Resistor	1	8890A060
Resistor O-Ring	1	5-230
Clamping Band Assembly	1	2430-055
Plug Vent Shipping	1	2450-094 2450-049
Overtemp Thermoswitch	1	8890-008
Coolant, 1.5 gal (5.7 liter)	1	5-1070-3
Radiator Assembly	1	8860-002-2
Access Plug 3/4"-14 Hex Socket	1	5020-103

Available “QC” Type Connectors

Connector	Part Number
BNC-Female	4240-125
BNC-Male	4240-132
C-Female	4240-100
C-Male	4240-110
HN-Female	4240-268
HN-Male	4240-278
LC-Female*	4240-031
LC-Male	4240-025
Open Term.# 10-32 Nut	4240-080
Mini UHF-Female	4240-346
UHF-Female	4240-050
UHF-Male	4240-179
1-5/8" EIA Fixed	4240-096
1-5/8" EIA Swivel	4240-208
7/8" EIA	4240-002
TNC-Female	4240-156
TNC-Male	4240-160
LT-Female	4240-018
LT-Male	4240-012
N-Female	4240-062
N-Male	4240-063
SC-Female	4240-090
SMA-Female	4240-336
SMA-Male	4240-334
7/16 Jack, IEC, Type 169-4	4240-344
7/16 Plug, IEC, Type 169-4	4240-363

* Normally supplied

LIMITED WARRANTY

All products manufactured by Seller are warranted to be free from defects in material and workmanship for a period of one year, unless otherwise specified, from date of shipment and to conform to applicable specifications, drawings, blueprints and/or samples. Seller's sole obligation under these warranties shall be to issue credit, repair or replace any item or part thereof which is proved to be other than as warranted; no allowance shall be made for any labor charges of Buyer for replacement of parts, adjustment or repairs, or any other work, unless such charges are authorized in advance by Seller.

If Seller's products are claimed to be defective in material or workmanship or not to conform to specifications, drawings, blueprints and/or samples, Seller shall, upon prompt notice thereof, either examine the products where they are located or issue shipping instructions for return to Seller (transportation-charges prepaid by Buyer). In the event any of our products are proved to be other than as warranted, transportation costs (cheapest way) to and from Seller's plant, will be borne by Seller and reimbursement or credit will be made for amounts so expended by Buyer. Every such claim for breach of these warranties shall be deemed to be waived by Buyer unless made in writing within ten (10) days from the date of discovery of the defect.

The above warranties shall not extend to any products or parts thereof which have been subjected to any misuse or neglect, damaged by accident, rendered defective by reason of improper installation or by the performance of repairs or alterations outside of our plant, and shall not apply to any goods or parts thereof furnished by Buyer or acquired from others at Buyer's request and/or to Buyer's specifications. Routine (regularly required) calibration is not covered under this limited warranty. In addition, Seller's warranties do not extend to the failure of tubes, transistors, fuses and batteries, or to other equipment and parts manufactured by others except to the extent of the original manufacturer's warranty to Seller.

The obligations under the foregoing warranties are limited to the precise terms thereof. These warranties provide exclusive remedies, expressly in lieu of all other remedies including claims for special or consequential damages. SELLER NEITHER MAKES NOR ASSUMES ANY OTHER WARRANTY WHATSOEVER, WHETHER EXPRESS, STATUTORY, OR IMPLIED, INCLUDING WARRANTIES OF MERCHANTABILITY AND FITNESS, AND NO PERSON IS AUTHORIZED TO ASSUME FOR SELLER ANY OBLIGATION OR LIABILITY NOT STRICTLY IN ACCORDANCE WITH THE FOREGOING.

