



Advanced Test Equipment Corp.

www.atecorp.com 800-404-ATEC (2832)



## Agilent PSG Signal Generators

### Aerospace and defense

- Radar and electronic warfare
- Secure communications
- Satellite communications

### Commercial communications

- Broadband wireless access
- Point-to-point/multipoint digital microwave radio
- Mobile communications

### General purpose

- Component analysis
- LO and clock substitution
- Interference generation



**Agilent Technologies**

## Setting a Higher Standard

*High-performance signal generation solutions ranging from CW-only to advanced signal simulation*



### Higher frequency, higher power, and higher performance

Agilent PSG signal generators provide the microwave signal generation technology for your expanding test needs. Featuring the industry's first analog signal generator with frequency ranges up to 67 GHz (operational to 70 GHz), first signal generator to break the 1 Watt output barrier, and first vector signal generator up to 44 GHz, the PSG is poised to accelerate innovation for your high-frequency designs in the aerospace, defense, and communications industries. PSG signal generators maintain worldwide leadership in microwave signal generation by offering the frequency coverage, feature set, and performance you need to be successful in today's increasingly technical test environment.

When performing functional and parametric tests on advanced RF and microwave radio systems, analyzing the components that comprise them, or simply substituting a continuous-wave (CW) signal for a local oscillator, the PSG delivers high-quality signals to test your state-of-the-art designs. Generate pulsed signals for radar test, vector-modulated signals for receiver bit error rate (BER) analysis, and even play back simulated waveforms for advanced system-level verification—with PSG signal generators, the possibilities are endless. Choose from three PSG models to meet your signal generation requirements: the E8257D PSG microwave analog, the E8663D PSG RF analog, and the E8267D PSG microwave vector.

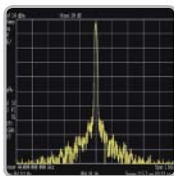

*Continuous wave*

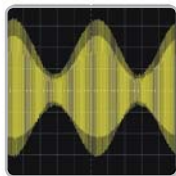

*Analog modulation*

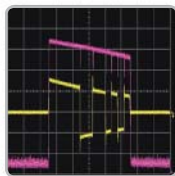

*Pulse modulation*

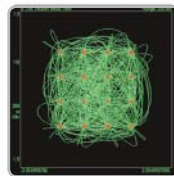

*Digital modulation*

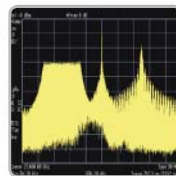

*Signal simulation*

# E8257D PSG Analog Signal Generator

ANALOG  
Foundation of  
Performance

*Delivering unmatched performance and versatility*



## Benchmark signal quality

An industry-leading combination of phase noise and output power performance, together with precision analog and pulse modulators, have made the PSG the instrument of choice for RF and microwave design engineers worldwide. The E8257D PSG analog signal generator offers excellent output power and level accuracy up to 70 GHz, exceptional close-to-carrier phase noise, wider deviation for FM and  $\Phi$ M, and frequency extensions up to 500 GHz using Oleson Microwave Labs (OML) mm-wave source modules. With this capability and performance, the PSG continues to be the worldwide leader in microwave signal generation.

## Modular platform

PSG signal generators feature a modular platform with room to grow—serving your test needs now and in the future. The highly flexible option structure enables you to configure the PSG to accommodate your specific test applications as well as your budget requirements. Choose from multiple options to tailor the performance of the PSG, such as frequency range, output power, phase noise, types of modulation, and more. And, since many options can be retrofitted yourself or at an Agilent Service Center, you can select the performance you need today, knowing you can quickly and easily upgrade later.

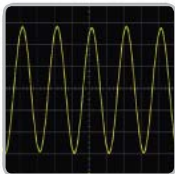

CW

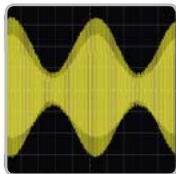

AM

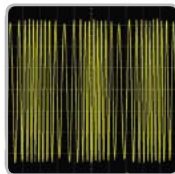

FM

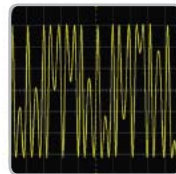

$\Phi$ M

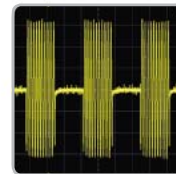

Pulse

## CW signal generation

- 250 kHz to 20, 31.8, 40, 50, or 70 GHz
- Industry leading output power—up to 1 Watt
- Precision level accuracy
- Lowest phase noise
- Swept frequency and power
- Frequency extensions to 500 GHz using OML mm-wave source modules

## Plus optional analog and pulse modulation

- Two internal LF function generators with sine, square, triangular, ramp, and noise waveforms
- Deep log and linear AM
- Scan modulation
- Wideband DC-synthesized FM and  $\Phi$ M
- Narrow pulse modulation

1. Code compatibility available for the Agilent 834xB, 837xx, 836xx, E824x/E825xA, and E82x7C microwave signal generators and Agilent 8662A, 8663A, 8643A, 8644B, E443xB, and E44x8C RF signal generators.

# E8257D PSG Analog Signal Generator

ANALOG  
Foundation of  
Performance

Designed for your test applications

## Ideal for LO substitution and low jitter clock replacement

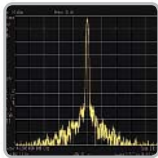

Boasting the widest frequency range, exceptional spectral purity, and high output power, the PSG analog is ideal for LO substitution and low jitter clock replacement. The PSG's industry-leading phase noise and spurious performance minimizes distortion that would normally be translated directly to mixer products. This results in less stringent filter requirements at the mixer output and improved signal quality for minimum test uncertainty. With clearly specified low-jitter characteristics, the PSG offers superior system clock performance. If your application only requires CW signals, the PSG's modular architecture allows a lower acquisition cost, since analog and pulse modulators are optional.

## Unrivaled for component analysis



Accuracy, repeatability, and speed are essential to meet your test throughput goals. For component analysis and stimulus/response applications, the PSG offers high output power, outstanding level accuracy, low harmonics and spurious distortion, and fast analog and digital sweep of frequency and power. Analog (AM, FM, and FM) and pulse modulators can also be applied during sweep operation. Using a high-performance microwave signal generator in combination with a scalar network analyzer or spectrum analyzer for swept analysis applications, you will realize the benefits of economy, convenience, and extended dynamic range in one measurement system.

## Use as a tracking generator with the PSA spectrum analyzers



PSG

PSA equipped with Option 215

## Use as a swept source for scalar network analysis

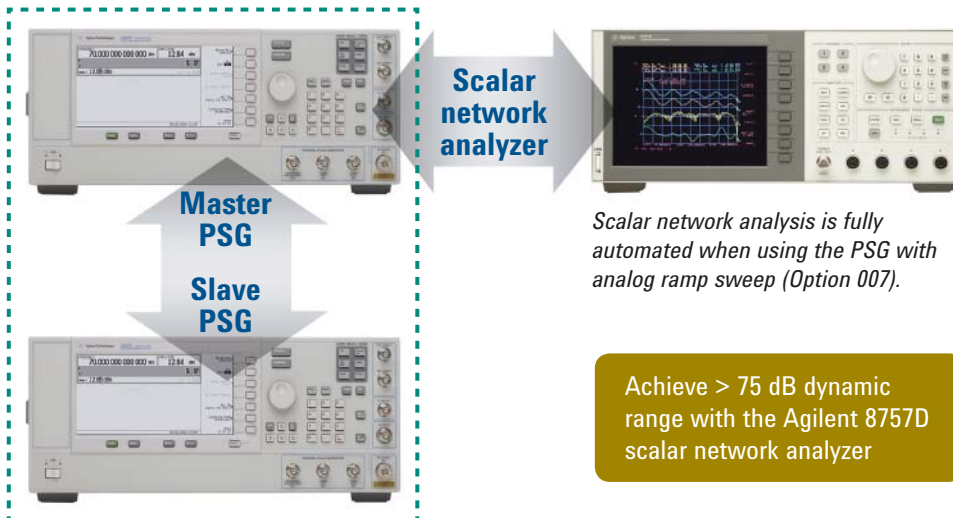

Scalar network analysis is fully automated when using the PSG with analog ramp sweep (Option 007).

Achieve > 75 dB dynamic range with the Agilent 8757D scalar network analyzer

Supports master/slave operation for swept two-tone signal generation.

Delivering power, spectral purity, and wideband analog modulation

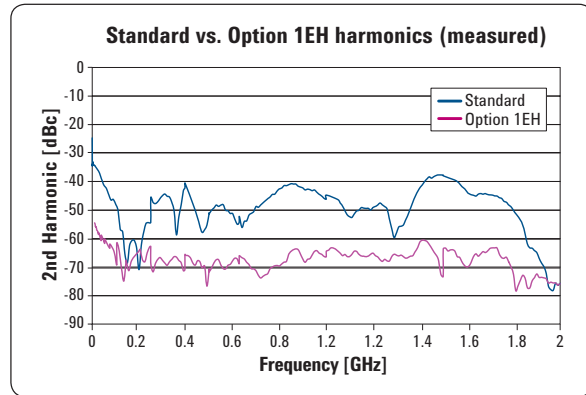
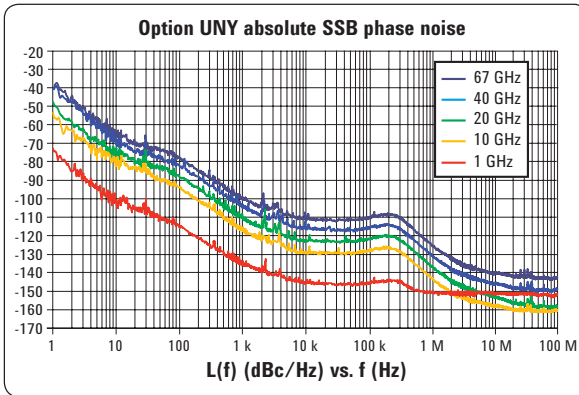
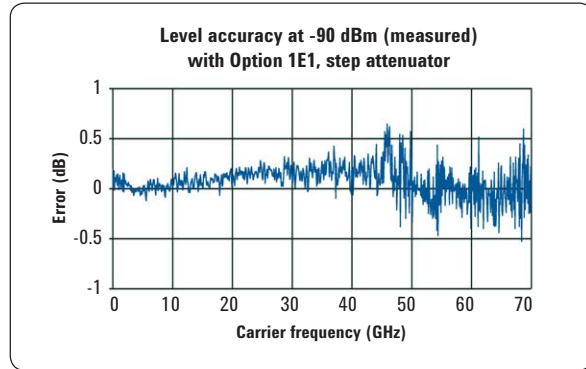
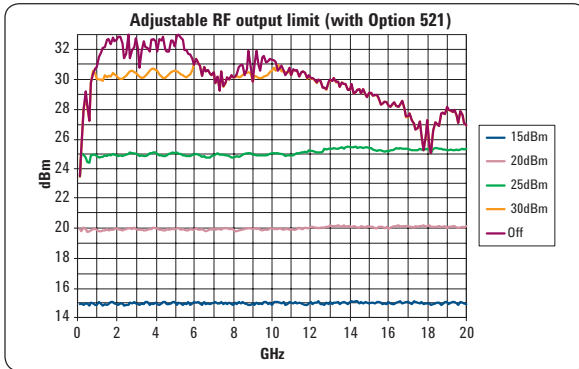

## Specification summary<sup>1,2</sup>

Ultra-low phase noise (Option UNY)	
$f_c = 10$ GHz	
(100 Hz offset)	-91 dBc/Hz
(1 kHz offset)	-107 dBc/Hz
(10 kHz offset)	-126 dBc/Hz
(100 kHz offset)	-125 dBc/Hz
High output power (Option 1EU)	
at 20 GHz	+ 23 dBm
at 30 GHz	+ 19 dBm
at 40 GHz	+ 17 dBm
at 50 GHz	+ 14 dBm
at 67 GHz	+ 14 dBm
67 to 70 GHz	+ 8 dBm
Level accuracy	
(CW level = -10 to 0 dBm)	
$f_c = 2$ to 20 GHz	± .8 dB
$f_c = 20$ to 40 GHz	± .9 dB
$f_c = 40$ to 50 GHz	± .9 dB
$f_c = 50$ to 67 GHz	± 1.0 dB

Switching speed	
(list mode)	< 5 ms
Analog modulation (Option UNT)	
AM	
Bandwidth	100 kHz
Depth	
Linear	> 95%
Exponential	> 40 dB
FM	
Bandwidth	dc to 10 MHz
Maximum deviation	
20 GHz < $f_c$ ≤ 40 GHz	64 MHz
40 GHz < $f_c$ ≤ 67 GHz	128 MHz
ΦM	
Bandwidth	dc to 1 MHz
Maximum deviation	
20 GHz < $f_c$ ≤ 40 GHz	64 radians
40 GHz < $f_c$ ≤ 67 GHz	1280 radians
Narrow pulse modulation (Option UNW)	
Rise/fall time	6 ns
Minimum pulse width	20 ns
On/off ratio	80 dB

1. Numbers in italics indicate typical performance.  
 2. Specifications subject to change without notice.

Delivering the highest RF signal generation performance up to 9 GHz

### The ideal reference source for phase noise test systems

A phase noise test system is only as good as the reference source used for device under test (DUT) comparison. The E8663D's outstanding close-in phase noise makes it an excellent choice for use with the Agilent E5500 phase noise test system. Order Option UNY for the lowest possible close-in and pedestal phase noise.

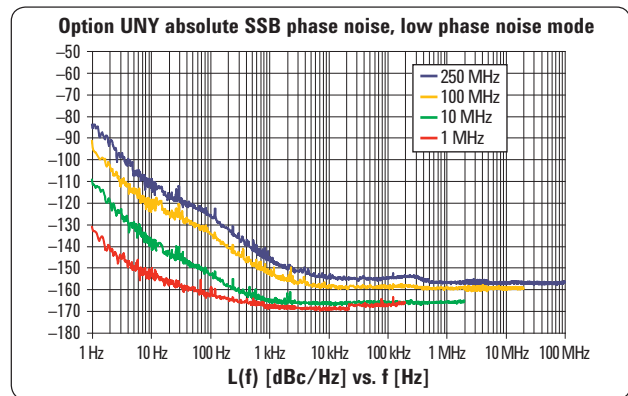
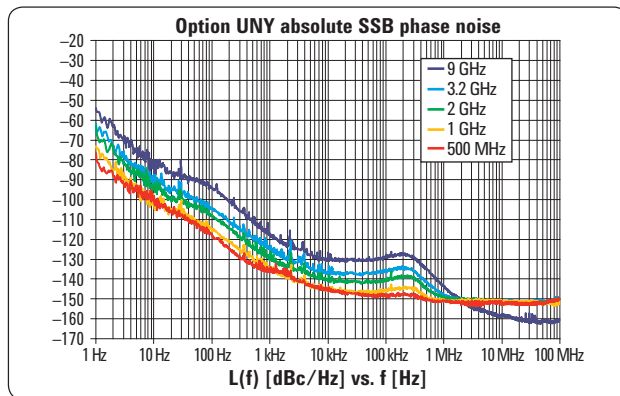
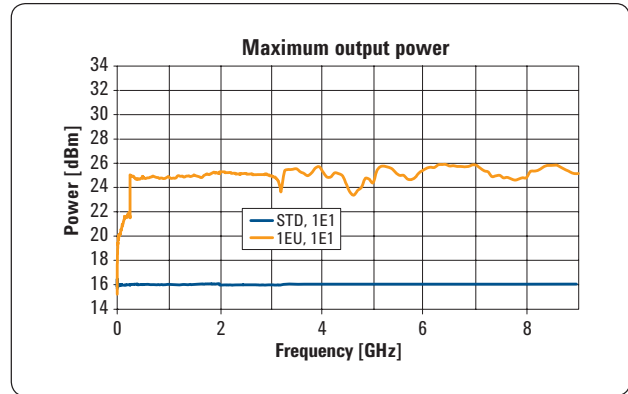

### Specification summary<sup>1,2</sup>

Enhanced ultra-low phase noise (Option UNY)	
$f_c = 1 \text{ GHz}$	
(100 Hz offset)	-111 dBc/Hz
(1 kHz offset)	-128 dBc/Hz
(10 kHz offset)	-143 dBc/Hz
(100 kHz offset)	-144 dBc/Hz
High output power (Option 1EU)	
at 3.2 GHz	+ 23 dBm
at 9.0 GHz	+ 23 dBm
Level accuracy	
(CW level = -10 to +16 dBm)	
250 kHz to 2 GHz	± 0.6 dB
> 2 to 9 GHz	± 0.8 dB
Narrow pulse modulation (Option UNW)	
Rise/fall time	6 ns
Minimum pulse width	20 ns
On/off ratio	80 dB

Switching speed	
(list mode)	
Frequency	11 ms
Amplitude	6 ms
Analog modulation (Option UNT)	
AM	
Bandwidth	100 kHz
Depth	
Linear	> 95%
Exponential	> 40 dB
FM	
Bandwidth	dc to 10 MHz
Maximum deviation	
> 2 to 3.2 GHz	8 MHz
> 3.2 to 9 GHz	16 MHz
ΦM	
Bandwidth	dc to 1 MHz
Maximum deviation	
> 2 to 3.2 GHz	80 radians
> 3.2 to 9 GHz	160 radians

1. Numbers in italics indicate typical performance.  
 2. Specifications subject to change without notice.

# E8267D PSG Vector Signal Generator

VECTOR

Accelerating  
Innovation

*Leading the industry in vector signal generation*

## Step up to integrated vector technology

An industry first—vector signal generation at microwave frequencies—and now the industry standard, the E8267D PSG offers an outstanding feature set that drastically simplifies the generation of complex vector modulated signals for designing and manufacturing test applications in radar, satellite communications, and broadband communications. With frequency ranges up to 44 GHz, the PSG vector

provides groundbreaking functionality that includes a built-in wideband I/Q modulator with up to 2 GHz RF modulation bandwidth (BW) and an advanced wideband (80 MHz BW) internal baseband generator capable of flexible arbitrary waveform playback and sophisticated real-time signal generation.

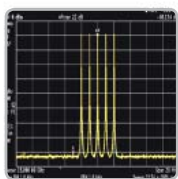

Multitone

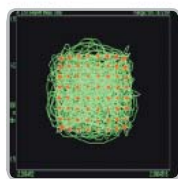

Digital modulation

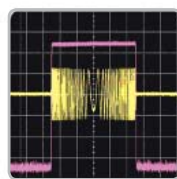

FM chirp pulse

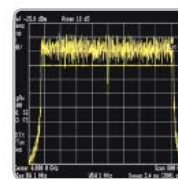

Wideband modulation

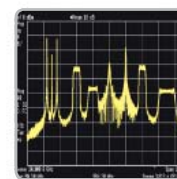

Signal simulation



### Built on the foundation of analog performance

- Industry-leading phase noise
- High output power
- Precision level accuracy

## Integrated vector solution

- 250 kHz to 20, 31.8, or 44 GHz
- Integrated wideband I/Q modulator
- External I/Q inputs (up to 2 GHz BW)
- Internal baseband generator (up to 80 MHz BW)
  - Arbitrary waveform playback with sequencing
  - Real-time I/Q symbol generation
  - Digital modulation: FSK, PSK, MSK, QAM, custom I/Q
  - Single and multicarrier (up to 100 carriers)
  - 16-bit upsampling DACs running at 400 MHz
  - Up to 64 MSa waveform playback memory
  - Up to 8 GB waveform storage
- Signal Studio software for signal creation

## Optional analog capability

- Two internal LF function generators with sine, square, triangular, ramp, and noise waveforms
- Deep log/linear AM and scan modulation
- Wideband DC-synthesized FM, and FM
- Narrow pulse modulation
- Swept frequency and power
- Frequency extensions to 500 GHz using OML mm-wave source modules<sup>1</sup>
- Tracking capability with PSA Series spectrum analyzers
- Code compatibility to ease automation during test system upgrades<sup>2</sup>

1. Frequency extensions with OML mm-wave source modules do not support vector modulation.

2. Code compatibility available for the Agilent 834xB, 837xx, 836xx, E824x/E825xA, and E82x7C microwave signal generators and Agilent 8662A, 8663A, 8643A, 8644B, E443xB, and E44x8C RF signal generators.

# E8267D PSG Vector Signal Generator

VECTOR

Accelerating Innovation

## Eliminate upconversion

If you've spent time building a custom upconversion solution to generate vector-modulated signals at microwave frequencies, then you know the challenges surrounding conversion loss, filtering, repeatability, calibration, and support. Agilent's E8267D PSG is the world's first commercial off-the-shelf signal generator to address these issues with an integrated solution for vector modulation at microwave frequencies up to 44 GHz.

## Modern microwave test

Built on the PSG analog's proven foundation of performance, the PSG vector signal generator is equipped with signal creation tools, advanced baseband generation, and integrated wideband I/Q modulation, to simplify signal simulation. It provides a repeatable calibrated test stimulus with unprecedented flexibility, output power, and signal quality for your test applications—and it's all backed by Agilent support.

The PSG can be configured to address very specific test applications and still provide general-purpose signal generation capabilities, making it the most versatile signal generator in the world. This breakthrough in technology is transforming microwave test from a custom approach to a systematic method that streamlines integration, improves throughput, and drives interoperability. Modernizing your test systems with the PSG vector signal generator will help get your products to market faster by accelerating test and improving yield.

## Solutions for vector modulation at microwave frequencies

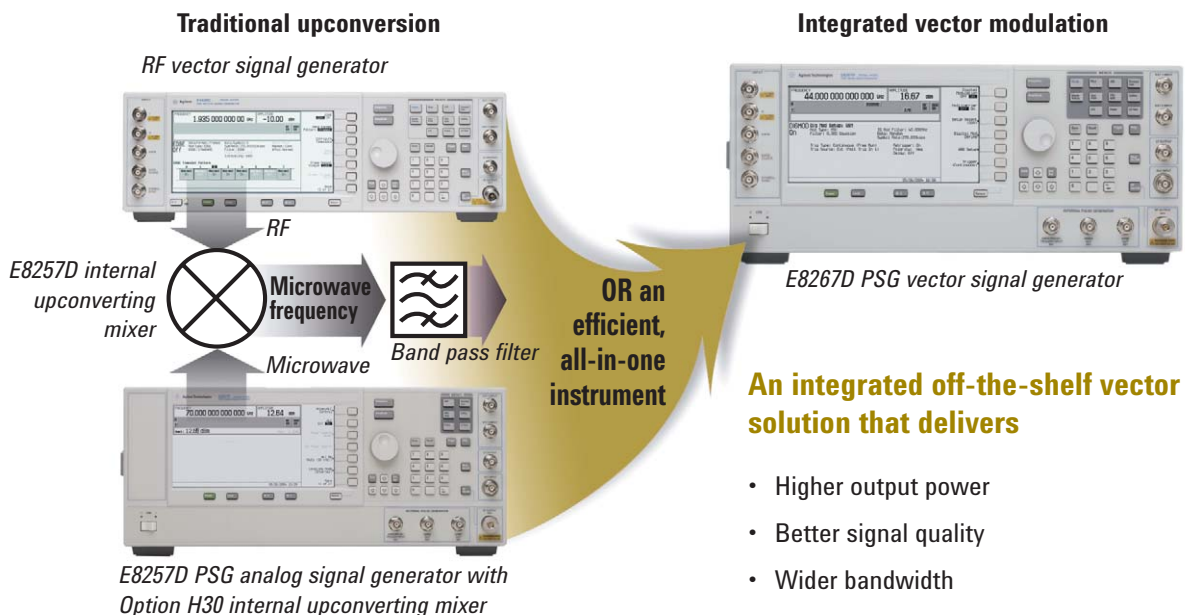

## An integrated off-the-shelf vector solution that delivers

- Higher output power
- Better signal quality
- Wider bandwidth
- Efficient signal modification
- Lower calibration and support costs
- Smaller footprint



## Realistic signal simulations

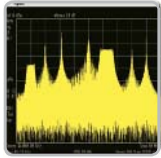

Vector modulation opens up signal simulation possibilities that are unattainable with analog modulation. With the PSG vector signal generator, it is easier to create realistic signal simulations to test radar and electronic warfare, satellite, and broadband wireless communications systems. Whether performing parametric tests on components and devices, or functional tests on subsystems and systems, testing with realistic signal simulations allows you to identify and address issues early in the design process and gain confidence that, when deployed, your designs will be successful.

Featuring an internal baseband generator capable of arbitrary waveform playback and real-time I/Q signal generation, plus support for external arbitrary waveform generators with RF modulation bandwidths up to 2 GHz, you now have convenient access to advanced signal simulation technology for generating real-world test signals up to 44 GHz.

With integrated, calibrated, wideband vector signal generation at your fingertips, the signal simulation possibilities are endless. Easily add a variety of signal impairments, simulate interference conditions, and even generate phase coherent signals to test direction finding and other multi-receiver systems.

The PSG is the perfect complement to your RF and microwave signal simulation and analysis lab. When combined with Agilent Advanced Design System software (ADS), PXA signal analyzers, 89600 Series vector signal analysis software, and Infiniium oscilloscopes, you have the bandwidth and dynamic range to successfully develop your high-performance radio designs, and the flexibility to ensure you've exercised all possible operating conditions.

## Designed for your test applications

### Radar

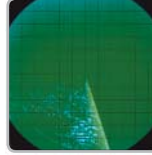

The PSG vector signal generator utilizes deep waveform playback memory, flexible waveform sequencing, and wideband I/Q modulation to generate complex pulse patterns for radar receiver tests.

Using the PSG's vector-modulated arbitrary waveforms improves repeatability and eliminates many of the synchronization issues associated with pulsing modulated signals using traditional analog techniques. Simply define arbitrary waveforms representing pulsed radar signals using Agilent Signal Studio for pulse building, ADS or other popular waveform creation tools, such as MATLAB, and download them to the PSG for playback. With full control over pulse frequency, phase, amplitude, and modulation characteristics on a pulse-by-pulse basis, you can generate the long non-repetitive pulse patterns you need to fully test your advanced radar systems.

### Satellite



Due to the high risk and cost associated with launching a satellite, extensive testing is required while designing and developing the navigation, control, and communications systems.

Investing in a single, integrated instrument, that features flexible signal generation and guaranteed calibrated performance, can save you valuable time in your current test processes, increase the accuracy of your test results, and enable new test possibilities. With a single PSG vector signal generator, you can easily produce digitally modulated signals, custom pulse patterns, multitone distortion, and noise power ratio (NPR) test signals.

### Broadband communications

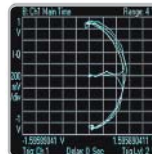

Modern commercial and military communications systems, such as WLAN, WiMAX™, and UWB, as well as secure tactical radio systems, continue to employ wider and wider bandwidths to

increase data rates and counteract frequency selective fading.

Using the PSG, you can easily generate reference signals to perform bit-error-rate (BER), packet-error-rate (PER), and frame-error-rate (FER) analysis on your receiver designs.

# E8267D PSG Vector Signal Generator

VECTOR

Accelerating  
Innovation

## Flexible signal generation

The PSG integrates the three fundamental components of vector signal generation with the utmost flexibility: I/Q signal creation, I/Q baseband generation, and I/Q modulated RF and microwave signal generation. Using a combination of embedded signal creation software and PC-based Signal Studio software, the PSG simplifies complex signal simulation and enables you to quickly realize your desired test stimulus.

The PSG supports both internal and external baseband generators, such as the N6030A/N8241A arbitrary waveform generators, and is compatible with the N5102A digital signal interface module for advanced baseband capability. All this, combined with calibrated I/Q modulation up to 44 GHz, gives you the most complete set of test signals for advanced radio design.

## Simplify signal creation

Further expand E8267D PSG signal generation capabilities with the addition of application-specific, easy-to-use signal creation software products. Signal Studio, a suite of PC-based software, and software embedded in the E8267D allow you to set various signal parameters for flexible and simple I/Q waveform creation. Agilent signal creation software reduces the time you spend on custom signal simulation at microwave frequencies while enabling you to better characterize, evaluate, and optimize your designs.

Download Signal Studio to a PC to review the user interface and investigate the signal creation capabilities of the software prior to purchase.

[www.agilent.com/find/signalstudio](http://www.agilent.com/find/signalstudio)

### General microwave

- Multitone
- NPR
- Jitter injection
- AWGN
- Toolkit

### Wireless connectivity

- WiMAX
- WLAN
- UWB
- Digital video

### Detection, tracking, positioning and navigation

- Pulse building
- GPS

### Mobile communication

- GSM/EDGE
- Bluetooth®
- W-CDMA
- cdma2000
- TDMA

## Create two-tone and multitone signals for distortion test

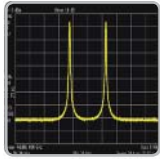

Signal Studio for multitone distortion optimizes the intermodulation distortion performance of two-tone and multitone test stimuli to accurately characterize non-linear distortion performance of your DUT.

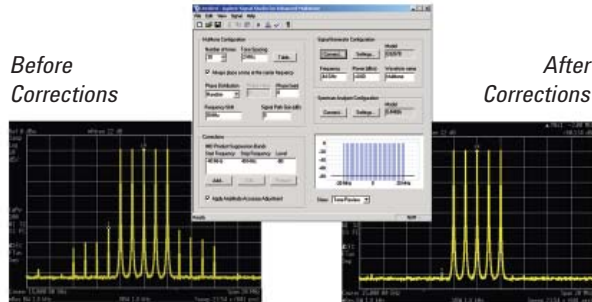

## Create noise signals to measure noise power ratio

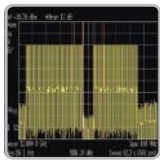

Signal Studio for multitone distortion also offers the ability to measure NPR. It creates a test stimulus with over 60 dBc notch depth, without using sensitive bandpass filters. Accurately measure distortion performance of your DUT, and easily configure a wideband noise signal with a user-defined notch width positioned within the noise bandwidth.

## Inject calibrated jitter for tolerance measurements



Signal Studio for jitter injection precisely creates periodic jitter and/or random jitter on CW signals sourced from the PSG vector signal generator. These test signals can be used to verify your high-speed digital transmission system clock recovery and regeneration circuit tolerance to unwanted jitter.

## Create pulse patterns for radar receiver test

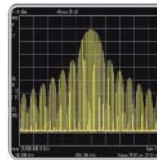

Signal Studio for pulse building enables flexible generation of complex pulse patterns. It provides a simple interface to construct and import custom pulse envelopes and apply various modulation types including Barker-coding and FM chirp.

## AWGN

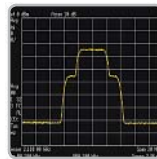

Transform the PSG into a flexible additive white Gaussian noise (AWGN) source with calibrated noise software embedded on the PSG. Option 403 provides uncorrelated noise with a bandwidth that can be continuously varied up to 80 MHz. Also, add calibrated noise to signals created with select Signal Studio software and precisely adjust signal-to-noise power directly from the software interface.

## GPS

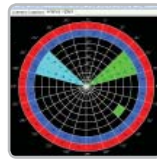

Easily create a multi-satellite GPS signal with real-world scenarios. Option 409 GPS personality provides GPS simulation of up to eight GPS satellites. Each satellite signal provides individual Doppler shifts and real GPS navigation messages for the scenario selected. For even more capability, add the Option 422 scenario generator to easily create GPS scenario files for a desired location, date, and time.

# E8267D PSG Vector Signal Generator

VECTOR

Accelerating  
Innovation

## Options for advanced baseband generation

### Internal baseband generator

The PSG vector signal generator equipped with the optional internal baseband generator (Option 602) integrates advanced baseband capability with a state-of-the-art vector signal generator to facilitate complex I/Q modulation at microwave frequencies. The high-performance dual-mode baseband generator combines arbitrary waveform generation (ARB mode) with sophisticated real-time I/Q symbol generation (real-time mode) to provide a complete baseband solution.



### Extend your test capability by adding digital I/O

The N5102A Baseband Studio digital signal interface module provides flexible digital inputs and outputs for your PSG. In the input mode, the interface module ports your digital input to the PSG baseband system, providing a quick and easy method for converting to calibrated analog I/Q, and upconverting to calibrated analog IF, RF, or MW frequencies. In output mode, the interface module delivers realistic, complex-modulated signals, such as communications signals and custom pulses, sourced from the PSG internal baseband generator directly to your digital subsystems and devices. In both operating modes, the interface module adapts to your device with the logic type, data format, clock features, and signaling types you require. With its three-meter extension cable and a selection of connector types, the interface module connects easily to your device, in most cases eliminating the need for custom fixtures.



### Wideband arbitrary waveform generator

For complex wideband signal generation at microwave frequencies, Agilent N6030/31A and N8241/42A arbitrary waveform generators (AWGs), combined with the PSG vector signal generator, deliver unprecedented performance. High sampling rate and bit resolution enable designers to create ideal waveforms for accurate testing of radar, satellite, and frequency-agile systems. Each channel of the N603xA/N824xA provides up to 500 MHz of modulation bandwidth and up to 65 dBc dynamic range. When the N603xA/N824xA AWGs are used with the PSG's wideband I/Q modulator, you can realize authentic signal simulations with RF modulation bandwidth of up to 1 GHz for IF and RF subsystem test.

For applications that require an extremely wide bandwidth, the 81180A arbitrary waveform generator provides up to 2 GHz I/Q modulation bandwidth (1 GHz/channel) and a variable sample rate of 10 MS/s to 4.2 GS/s. With 12 bits of vertical resolution, the Agilent 81180A provides a high level of spurious-free dynamic range. The advanced sequencing capabilities define stepping, looping, and conditional jumps of waveforms or waveform sequences, to make the most of the 64 MSA waveform memory. For even greater flexibility, use the 8-bit external input for dynamic control of segments and sequences.



## Wideband vector modulation

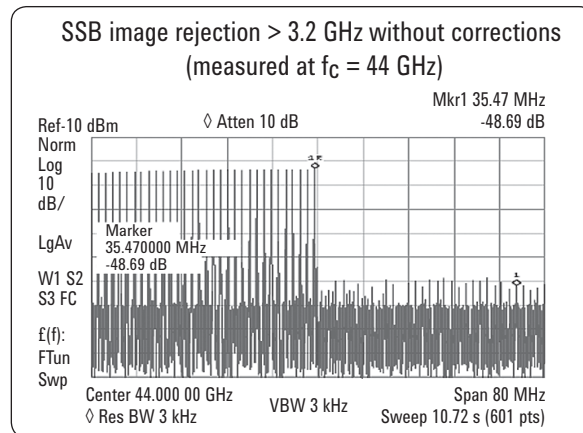
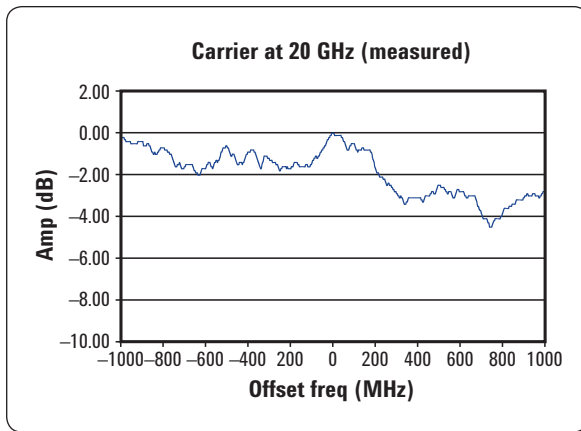

## Specification summary<sup>1,2</sup>

Enhanced ultra-low phase noise (Option UNY)	
$f_c = 1$ GHz	
(100 Hz offset)	-91 dBc/Hz
(1 kHz offset)	-107 dBc/Hz
(10 kHz offset)	-126 dBc/Hz
(100 kHz offset)	-125 dBc/Hz
High output power	
at $f_c = 20$ GHz	+ 22 dBm
at $f_c = 40$ GHz	+ 18 dBm
Level accuracy	
(CW level = -10 to +10 dBm)	
$f_c > 2$ to 20 GHz	± 0.8 dB
$f_c > 20$ to 32 GHz	± 0.9 dB
$f_c > 32$ to 40 GHz	± 0.9 dB
Switching speed	
(list mode)	< 9 ms
Analog modulation (Option UNT)	
AM	
Bandwidth	100 kHz
Modes	
Linear	> 95%
Exponential	> 40 dB
FM	
Bandwidth	dc to 10 MHz
Maximum deviation	
10 GHz < $f_c$ to 20 GHz	32 MHz
20 GHz < $f_c$ to 28.5 GHz	48 MHz
28.5 GHz < $f_c$ to 44 GHz	80 MHz

ΦM	
Bandwidth	dc to 1 MHz
Maximum deviation	
10 GHz < $f_c$ 20 GHz	320 radians
20 GHz < $f_c$ 28.5 GHz	480 radians
28.5 GHz < $f_c$ 44 GHz	800 radians
Pulse modulation (Option UNW)	
Rise/fall time	6 ns
Minimum pulse width	20 ns
On/off ratio	80 dB
RF modulation bandwidth	
External I/Q inputs	Up to 160 MHz
Wideband external I/Q inputs	Up to 2 GHz
Internal baseband generator	
RF modulation bandwidth	Up to 80 MHz
Waveform playback memory	64 MSa
Waveform storage memory	1.2 GSa
Sample rate	Up to 100 MSa/s
Symbol rate	Up to 50 Msym/s
DAC resolution	16-bit
Modulation formats	
PSK:	BPSK, QPSK, OQPSK, π/4DQPSK, 8PSK, D8PSK, 16PSK
MSK:	User-defined phase offset from 0 to 100 °
QAM:	4, 16, 32, 64, 128, 256
FSK:	2, 4, 8, 16 level
Custom I/Q:	Custom map of 256 unique I/Q symbols
Multicarrier	
Number of carriers	Up to 100
Frequency offset	-40 MHz to +40 MHz
Power offset	0 to -40 dB
Multitone	
Number of tones	2 to 64 tones
Phase (per tone)	Fixed or random
Power offset (per tone)	0 to -40 dB

1. Numbers in italics indicate typical performance.  
 2. Specifications subject to change without notice.

# A Closer Look at the PSG

1. I and Q inputs
2. DATA input
3. DATA CLOCK input
4. SYMBOL SYNC input
5. TRIGGER key
6. EXT 1 INPUT for AM, FM, and FM
7. EXT 2 INPUT for AM, FM, and FM
8. LF OUTPUT for the low-frequency source function generator
9. ALC INPUT for external detector leveling
10. INTERNAL PULSE GENERATOR:
  - GATE/PULSE TRIGGER INPUT
  - VIDEO OUT
  - SYNC OUT

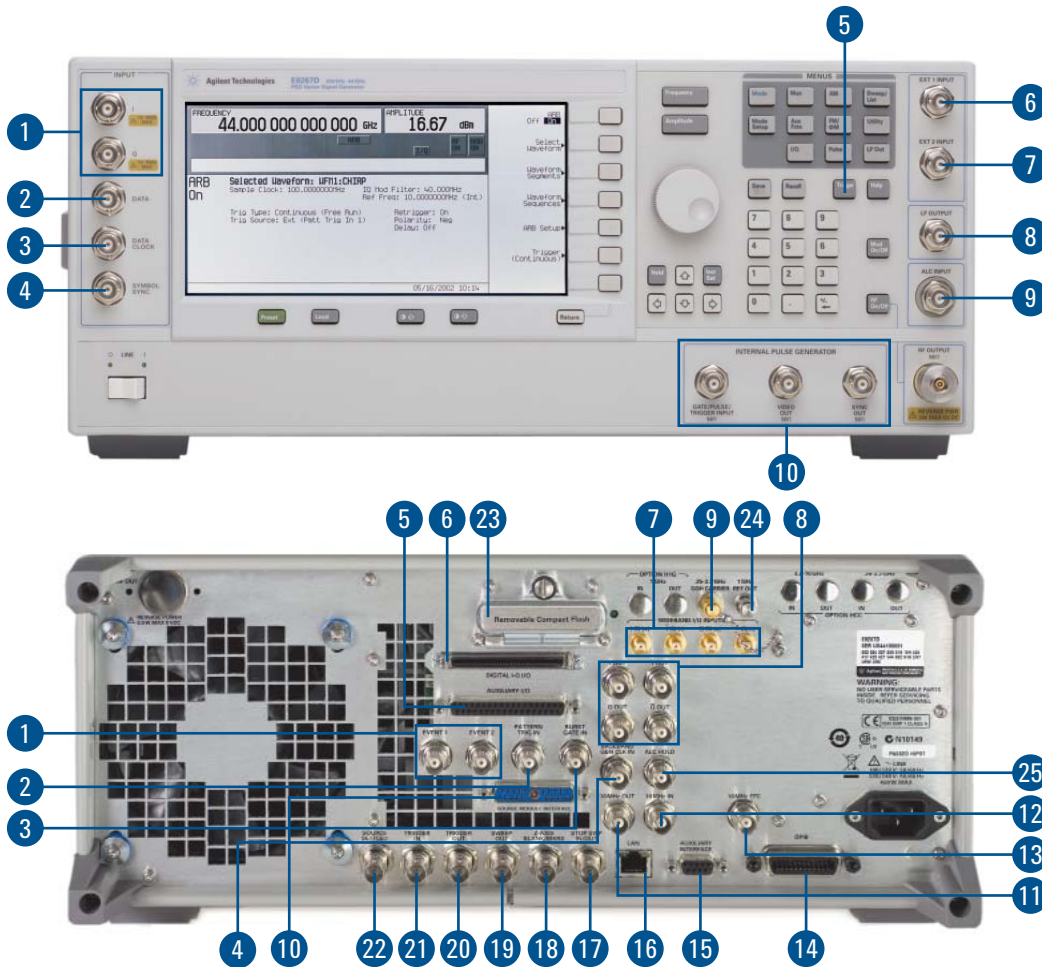

1. EVENT 1 and EVENT 2 outputs marker signals from the baseband generator
2. PATTERN TRIG IN triggers an internal pattern or frame to initiate an output
3. BURST GATE IN for gating bursted power
4. BASEBAND GEN CLK IN
5. AUXILIARY I/O provides access to various inputs and outputs
6. DIGITAL BUS used with Agilent Baseband Studio products
7. WIDEBAND I and Q inputs drive the PSG's wideband (2 GHz) I/Q modulator for custom vector modulation
8. Single-ended and differential I/Q outputs
9. COH (COHERENT CARRIER OUTPUT)
10. SMI (SOURCE MODULE INTERFACE) enables frequency generation up to 500 GHz with Agilent mm-wave source modules
11. 10 MHz Reference OUT
12. 10 MHz Reference IN
13. 10 MHz EFC INPUT
14. GPIB
15. AUXILIARY INTERFACE RS-232 port
16. LAN
17. STOP SWEEP IN/OUT
18. Z-AXIS BLANK/MKRS
19. SWEEP OUT
20. TRIGGER OUT
21. TRIGGER IN
22. SOURCE SETTLED output
23. Removable Compact Flash Access
24. 1 GHz REF OUT
25. ALC Hold

Note: available connectors vary depending on the PSG model and option structure configuration

## Options for Customized Test Needs

Agilent offers a variety of standard and special options to meet your customized test needs. If you require custom capability or performance, please contact your sales representative to determine if a unique option is available, or if one can be created to meet your unique needs.

### Lock up to 16 PSG vector signal generators to achieve phase coherency with special Option HCC

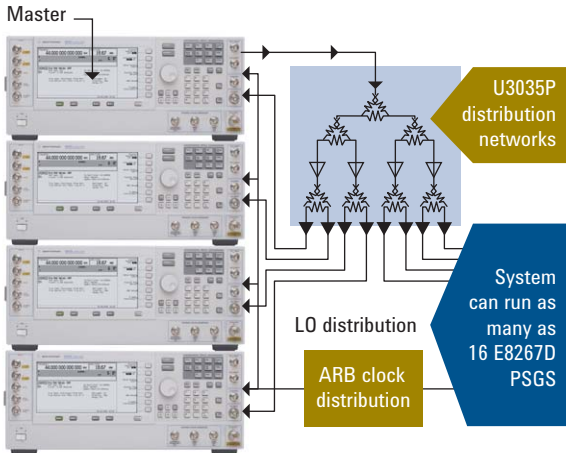

### Generate up to 16 phase-coherent signals

Testing multi-receiver systems used in phased-array radar, communications networks, and synthetic aperture radar has traditionally been difficult and expensive. Field testing, while perhaps necessary for final system verification, is an expensive method for the design phase. The phase-coherent simulation system, which consists of up to 16 E8267D PSGs and some special options, provides a more repeatable, configurable alternative for the laboratory or the flight line. As shown above, one PSG is the master, delivering the fundamental LO signal to the distribution network. The distribution network routes this signal back to the master and all the slaves as a common LO. An additional RF signal generator is used as the source to drive the external clock inputs of each PSG internal baseband generator. The system provides the full-phase coherency that is mandatory for testing multi-receiver systems, as well as full control over time, phase, amplitude, and frequency.

### Vector modulated signals up to 65 GHz

Generate vector modulated signals at frequencies up to 65 GHz using an E8257D equipped with special option H60 or H65 upconverting mixers in conjunction with an MXG, ESG, or PSG vector signal generator. In addition, an external filter is needed to eliminate unwanted mixing products for these special options.

### Wideband external inputs on the E8267D

The E8267D equipped with Option 016 enables external differential I/Q inputs to directly drive the PSG's leading-edge internal I/Q modulator with an external arbitrary waveform generator. For satellite and broadband communications applications, easily achieve up to 2 GHz RF modulation bandwidth (for carriers > 3.2 GHz) using optional wideband external analog I/Q inputs. Option 016 provides the bandwidth needed for high symbol rate custom modulation and wideband frequency hopping signals. Special Option H18, when added to Option 016, provides wide modulation bandwidth for carriers < 3.2 GHz.

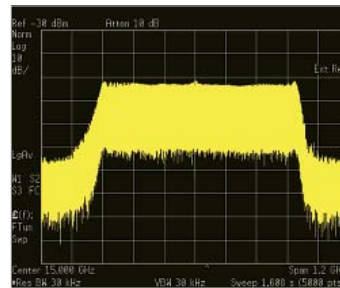

Realize up to 2 GHz modulation bandwidth with external inputs Option 016

### Scan modulation

Option 1SM adds scan modulation capability to the E8663D or E8257D (available with Option 520 only) to simulate a moving radar antenna beam. Realize up to 60 dB of modulation depth and more dynamic range for power sweep applications.

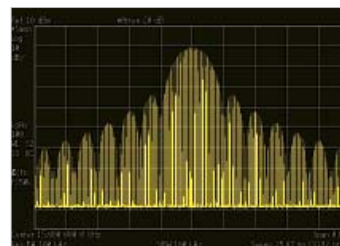

Add deep AM to the PSG for radar antenna test with scan modulation option 1SM

## Additional Resources

### Product literature

Agilent E8257D PSG Analog Signal Generator, Data Sheet, Literature number 5989-0698EN

Agilent E8257D PSG Analog Signal Generator, Configuration Guide, Literature number 5989-1325EN

Agilent E8267D PSG Vector Signal Generator, Data Sheet, Literature number 5989-0697EN

Agilent E8267D PSG Vector Signal Generator, Configuration Guide, Literature number 5989-1326EN

Agilent E8663D PSG RF Analog Signal Generator, Data Sheet, Literature Number 5990-4136EN

Agilent E8663D PSG RF Analog Signal Generator, Configuration Guide, Literature Number 5990-4137EN

### Web

For more information or to view product literature online, please visit:

[www.agilent.com/find/psg](http://www.agilent.com/find/psg)  
[www.agilent.com/find/signalstudio](http://www.agilent.com/find/signalstudio)

Learn more about microwave accessories, visit:  
[www.agilent.com/find/accessories](http://www.agilent.com/find/accessories)

WiMAX™ is a trademark of the WiMAX Forum®. Bluetooth® and the Bluetooth logos are trademarks owned by Bluetooth SIG, Inc, U.S.A. and licensed to Agilent Technologies, Inc.



Agilent Advantage Services is committed to your success throughout your equipment's lifetime. We share measurement and service expertise to help you create the products that change our world. To keep you competitive, we continually invest in tools and processes that speed up calibration and repair, reduce your cost of ownership, and move us ahead of your development curve.

[www.agilent.com/find/advantageservices](http://www.agilent.com/find/advantageservices)



[www.agilent.com/quality](http://www.agilent.com/quality)



### Agilent Email Updates

[www.agilent.com/find/emailupdates](http://www.agilent.com/find/emailupdates)  
Get the latest information on the products and applications you select.



[www.lxistandard.org](http://www.lxistandard.org)  
LXI is the LAN-based successor to GPIB, providing faster, more efficient connectivity. Agilent is a founding member of the LXI consortium.

### Agilent Channel Partners

[www.agilent.com/find/channelpartners](http://www.agilent.com/find/channelpartners)  
Get the best of both worlds: Agilent's measurement expertise and product breadth, combined with channel partner convenience.

## [www.agilent.com](http://www.agilent.com)

For more information on Agilent Technologies' products, applications or services, please contact your local Agilent office. The complete list is available at:

[www.agilent.com/find/contactus](http://www.agilent.com/find/contactus)

### Americas

Canada	(877) 894 4414
Brazil	(11) 4197 3500
Latin America	305 269 7500
Mexico	01800 5064 800
United States	(800) 829 4444

### Asia Pacific

Australia	1 800 629 485
China	800 810 0189
Hong Kong	800 938 693
India	1 800 112 929
Japan	0120 (421) 345
Korea	080 769 0800
Malaysia	1 800 888 848
Singapore	1 800 375 8100
Taiwan	0800 047 866
Thailand	1 800 226 008

### Europe & Middle East

Austria	43 (0) 1 360 277 1571
Belgium	32 (0) 2 404 93 40
Denmark	45 70 13 15 15
Finland	358 (0) 10 855 2100
France	0825 010 700* *0.125 €/minute
Germany	49 (0) 7031 464 6333
Ireland	1890 924 204
Israel	972-3-9288-504/544
Italy	39 02 92 60 8484
Netherlands	31 (0) 20 547 2111
Spain	34 (91) 631 3300
Sweden	0200-88 22 55
Switzerland	0800 80 53 53
United Kingdom	44 (0) 118 9276201

Other European Countries:

[www.agilent.com/find/contactus](http://www.agilent.com/find/contactus)

Revised: July 8, 2010

Product specifications and descriptions in this document subject to change without notice.

© Agilent Technologies, Inc. 2011  
Printed in USA, January 13, 2011  
5989-1324EN



**Agilent Technologies**