



STS100  
PORTABLE SECONDARY INJECTION TEST SET  
FOR THE FB600E

---

INSTRUCTION MANUAL

Rev.A2 17/10/96

# **1.0 INTRODUCTION**

---

## **1.1 Product Description**

The STS100 is a portable Secondary Injection Test Set used to test the FB600E Trip Device. The STS100 has a built in timer, ammeter and current source, an output for an actuator to control a breaker and protective circuitry to guarantee that internal components are not damaged by heating. The entire package can be carried by hand as it weighs 13 kg (28 lbs) and can be connected directly to the FB600E without the need for an interface module or isolation transformer. All of the functions are available at the push of a button and the digital time and digital current displays provide accurate and easy to read test results.

## **1.2 Features**

The STS100 provides the following output ranges selected with **RANGE** button:

1. 0 - 2 Amps continuous
2. 0 - 8 Amps for 24 seconds on, 120 seconds off
3. 0 - 10 Amps for 12 seconds on, 60 seconds off
4. 0 - 12 Amps for 0.6 seconds on, 3 seconds off

These 4 output ranges will allow testing of **all** FB600E functions including Long Time, Short Time, Instantaneous and Ground Fault overload. For standard testing, Long Time can be tested using Range 1 or 2, Short Time using Range 2 or 3, Instantaneous using Range 3 or 4 and Ground Fault using Range 1 or 2.

The current level is adjusted using the **CURRENT ADJUST** dial and is displayed on the digital ammeter. The **PHASE SELECT** button selects the phase to be tested, the **ON** and **OFF** buttons enable and disable the signal current output, the **START** button initiates a test and the **RESET** button readies the STS100 for the next test. When the **CONTINUOUS CURRENT** switch is **ON** the phase power output current is on continuously. This switch should remain **ON** when testing the FB600E so there is always power supplied to it. If another trip device other than the FB600E is used which is powered from the signal inputs (as opposed to having a separate power input), then this switch can be turned **OFF**. The STS100 is essentially a current source with a timer and an ammeter. As long as the output levels and time ranges are adequate, any relay or trip device can be tested with it.

See **3.0 Principles of Operation** for a detailed description of the testing procedures.

## 2.0 SETUP

---

### 2.1 Connections

The STS100 can be plugged into any standard 120 Volt outlet. Cables are provided to make the connections between the FB600E and the STS100 (See Table 2.1 and Figure 2.1).

CONNECTIONS		
STS100	FB600E	External Actuator
<i>PHASE CURRENT</i>		
A	1	
B	2	
C	3	
G	4	
COM	5	
<i>PHASE POWER OUTPUT</i>		
A	6	
B	7	
C	8	
G	9	
GND	10	
A+ (Act. Signal)	11	Red
A- (Act. Signal)	12	White

Table 2.1

The actuator is connected in parallel with the wires from the FB600E to the STS100, but does not need to be connected for the STS100 timer to function.

## 2.0 SETUP

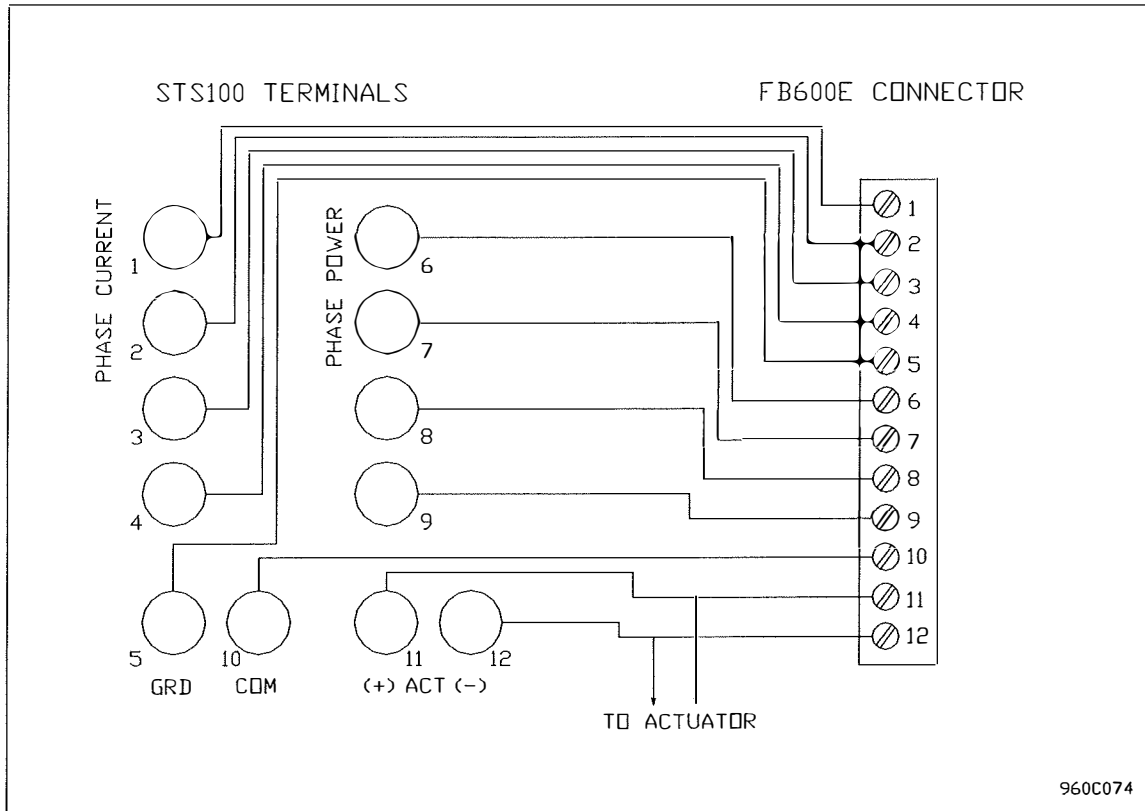

Figure 2.1 Connection Diagram

## **3.0 PRINCIPLES OF OPERATION**

---

### **3.1 Instructions**

1. After powering up the STS100, select the phase to be tested using the **PHASE SELECT** button.
2. Select the desired output range from section **1.2 Features** using the **RANGE SELECT** button
3. Adjust current using **CURRENT ADJUST** dial.
4. Press the **ON** button. If range 1 is selected the output is continuous and starts immediately. If any of the other three ranges are selected, the **START** button must be pressed (see #5). If testing the FB600E, make sure the **CONTINUOUS CURRENT** switch is ON so power is supplied to the trip device.
5. Perform the test by pressing the **START** button. If there is a trip signal, the **TRIP** light will come on. To perform the next test push the **RESET** button to reset both the timer and the trip signal indicator. If there is no trip signal during the test period, the **RESET** button must still be pushed to reset the timer for the next test.
6. When the **READY LED** is ON, the STS100 is ready to perform a test. If it is not, then wait for the appropriate cooling period (mentioned in **1.2 Features**) until it does come on and the unit will be ready to proceed. If another test is desired repeat steps 2 to step 6. If testing is complete, power down the STS100.

## 4.0 SPECIFICATIONS

---

### 4.1 Input

Nominal Input Voltage: 120 Vac (Custom Input Voltages Available)  
Nominal Input Frequency: 60 Hz  
Maximum Input Current: 2.5 Amps

### 4.2 Output

Current (Amps rms)	Time On (seconds)	Cooling Time (seconds)
0 - 2.0	Continuous	-
0 - 8.0	24.0	120
0 - 10.0	12.0	60
0 - 12.0	0.600	3

Current (Amps rms)	Maximum Voltage (Volts rms)
0 - 2.0	8.0
2.0 - 8.0	7.0
8.0 - 12.0	6.0

Nominal Output Frequency: 60 Hz  
Accuracy (time):  $\pm 1\%$   
Accuracy (current):  $\pm 1\%$

### 4.3 Functions

1. 0 - 2 Amps: Long Time and Ground Fault Response
2. 0 - 8 Amps: Long Time, Short Time and Ground Fault Response
3. 0 - 10 Amps: Long Time, Short Time and Instantaneous Response
4. 0 - 12 Amps: Instantaneous Response

### 4.4 Operating Environment

41 °F to 104 °F (5 °C to 40 °C)

### 4.5 Physical Dimensions

Size: 9¼ X 12 X 7½ inches (23.5 X 30.5 X 19 cm)  
Weight: 28 lbs. (13 kg)

## **4.0 SPECIFICATIONS**

---

### **4.6 Warranty**

The STS100 is warranted to be free of defects in material and workmanship for two years. The warranty is limited to repair or replacement of parts and does not apply to damages due to shipment or to damages occurring from misuse of the equipment.

### **4.7 Technical Support**



**Mailing Address:** Carriere Technical Industries  
5621 Finch Ave East  
Scarborough, Ontario, Canada  
M1B 2T9

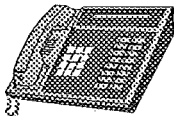

**Phone:** 1-800-263-2045

**E-Mail:** [custserv@carriere.com](mailto:custserv@carriere.com)