

METRIC

MIL-STD-1275E

22 MARCH 2013

SUPERSEDING

MIL-STD-1275D

29 August 2006

**DEPARTMENT OF DEFENSE
INTERFACE STANDARD**

**CHARACTERISTICS OF
28 VOLT DC INPUT POWER TO
UTILIZATION EQUIPMENT IN
MILITARY VEHICLES**



MIL-STD-1275E

FOREWORD

1. This standard is approved for use by all departments and agencies of the Department of Defense (DOD).
2. The intent of this document is to describe the nominal 28 VDC voltage characteristics, common across military ground vehicles, at the input power terminal of the utilizing electrical and electronic assemblies directly connected to the distribution network. This lays the groundwork for commonality across vehicle platforms. The vehicle's design authority is responsible to ensure that the 28 VDC delivered to the input power terminal of the utilization equipment meets these requirements.
3. This is neither a power source nor a power system standard. This standard focuses on utilization equipment and the conditions under which it is expected to operate.
4. Comments, suggestions, or questions on this document should be addressed to U.S. Army Tank automotive and Armaments Command, ATTN: RDTA-EN/STND/TRANS, MS# 268, 6501 E. 11 Mile Road, Warren, MI 48397 5000 or emailed to usarmy.detroit.rdecom.mbx.tardec-standardization@mail.mil. Since contact information can change, you may want to verify the currency of this address information using the ASSIST Online database at <https://assist.dla.mil>.

MIL-STD-1275E

Table of Contents

1	SCOPE	1
1.1	Scope	1
2	APPLICABLE DOCUMENTS	1
2.1	General	1
2.2	Government documents.....	1
2.2.1	Specifications, standards, and handbooks.....	1
2.3	Non-Government documents.	1
2.4	Order of precedence.	2
3	DEFINITIONS.....	2
3.1	Utilization equipment.....	2
3.2	Equipment under test.....	2
3.3	Operations.	2
3.3.1	Starting operation.....	2
3.3.2	Normal operation.	2
3.4	Operational voltage range.	2
3.5	Transient waveform characteristics.....	2
3.5.1	Rise time.	2
3.5.2	Fall time.	3
3.5.3	Recovery time.	3
3.5.4	Ripple.....	3
3.6	Types of transient waveforms.	3
3.6.1	Starting disturbance.	3
3.6.2	Voltage spike.	4
3.6.3	Voltage surge.	5
3.6.4	Intermittent contact.	6
3.7	Reverse polarity.....	6
4	GENERAL REQUIREMENTS	6
4.1	Reverse polarity.....	6
4.2	Electromagnetic compatibility.	7
4.3	Electrostatic discharge.....	7
5	DETAILED REQUIREMENTS	7
5.1	Voltage compatibility requirements.	7
5.1.1	Steady state operation.	7
5.1.2	Starting operation.....	7
5.1.3	Transient disturbances.	8
5.2	Voltage compatibility verification setup.	9
5.2.1	Environmental conditions.	9
5.2.2	Calibration of test equipment.....	10
5.2.3	Nominal voltage.....	10
5.2.4	Measurement tolerance.	10
5.2.5	Measurement reference point.....	11
5.2.6	Power return.....	11
5.2.7	Loads.....	11

MIL-STD-1275E

5.2.8	Power supply.....	11
5.3	Voltage compatibility verification method.	11
5.3.1	Steady state operation.	11
5.3.2	Starting operation.	12
5.3.3	Transient disturbances.	12
5.3.4	Reverse polarity.	15
5.3.5	Electromagnetic compatibility.....	15
5.3.6	Electrostatic discharge.	15
6	NOTES.....	15
6.1	Intended use.....	15
6.2	Acronyms.	15
6.3	International interest.....	16
6.4	Changes from previous issue.....	16
6.5	Subject term (key word) listing.....	16

Table of Figures

Figure 1.	Recovery time.....	3
Figure 2.	Sample starting disturbance waveform.	4
Figure 3.	Voltage spike.....	4
Figure 4.	Sample alternator load dump waveform.....	5
Figure 5.	Sample intermittent contact waveform.....	6
Figure 6.	Starting disturbance limits on 28VDC systems.....	8
Figure 7.	Envelope of spikes for 28VDC systems.....	9
Figure 8.	Envelope of surges for 28VDC systems.....	10
Figure 9.	Sample test setup for immunity to injected voltage spikes.	12
Figure 10.	Sample test setup for exported voltage spikes and surges.....	13
Figure 11.	Sample test circuit for immunity to injected voltage surges.	14

Table of Tables

Table I.	Positive voltage surge test parameters.....	14
----------	---	----

MIL-STD-1275E

1 SCOPE

1.1 Scope.

This standard defines the operating voltage limits and transient voltage characteristics of the 28 VDC electrical power at the input power terminals to the utilization equipment connected to the electrical power distribution system on military ground vehicle platforms.

2 APPLICABLE DOCUMENTS

2.1 General.

The documents listed in this section are cited in sections 3, 4 and 5 of this document. This section does not include documents cited in other sections of this standard or recommended for additional information or as examples. While every effort has been made to ensure the completeness of this list, the users of this standard are cautioned that they must meet all requirements of documents cited in sections 3, 4 and 5 of this standard, whether or not they are listed in this section.

2.2 Government documents.

2.2.1 Specifications, standards, and handbooks.

The following specifications, standards, and handbooks form a part of this document to the extent specified herein. Unless otherwise specified, the issues of these documents are those cited in the solicitation or contract.

DEPARTMENT OF DEFENSE

MIL-STD-461 - Requirements for the Control of Electromagnetic Interference Characteristics of Subsystems and Equipment

(Copies of these documents are available from <https://assist.dla.mil/quicksearch/> or from the Standardization Document Order Desk, 700 Robbins Avenue, Building 4D, Philadelphia, PA 19111-5094.)

2.3 Non-Government documents.

The following documents form a part of this document to the extent specified herein. Unless otherwise specified, the issues of documents are those cited in the solicitation or contract.

SAE INTERNATIONAL

SAE J1113-42 - Electromagnetic Compatibility—Component Test Procedure—Part 42—Conducted Transient Emissions

(Copies of these documents are available from www.sae.org or SAE Customer Service, 400 Commonwealth Drive, Warrendale, PA 15096-0001.)

MIL-STD-1275E

2.4 Order of precedence.

In the event of a conflict between the text of this document and the references cited herein, the text of this document takes precedence. Nothing in this document, however, supersedes applicable laws and regulations unless a specific exemption is obtained in writing from the applicable authority.

3 DEFINITIONS

3.1 Utilization equipment.

Utilization equipment is defined as the electronic device, equipment, or system subjected to the voltage range(s) indicated in this specification.

3.2 Equipment under test.

The Equipment Under Test (EUT) is defined as the electronic device, equipment, or system undergoing validation and/or verification testing or evaluation.

3.3 Operations.

3.3.1 Starting operation.

Electrical power during an engine starting event is sufficient for utilization equipment to provide the level of performance specified in the utilization equipment's detailed specification.

3.3.2 Normal operation.

Electrical power is sufficient for utilization equipment to provide the level of performance specified in the utilization equipment's detailed specification.

3.4 Operational voltage range.

Voltage characteristics representative of the nominal operating voltage within a pre-defined tolerance or limit. Some variation in voltage is reasonable and expected; however, this variation remains within pre-defined limits of operation.

3.5 Transient waveform characteristics.

A transient waveform represents a time-varying electrical signal defined by characteristics such as rise/fall time, period, frequency of oscillation, pulse width, etc. Transients typically exceed pre-defined steady-state limits, return to and remain within the steady-state limits within a specified time. The transient may have positive or negative polarity and/or be of short or long duration. Transient voltage levels may also exceed the system battery voltage by several hundred volts depending on the source of the transient.

3.5.1 Rise time.

The rise time is the difference between when the rising edge of a voltage or current transient crosses a pre-defined low threshold to when the transient crosses a pre-defined high threshold. As defined in this standard, the low threshold is defined to be the time at when the amplitude of the rising edge is equal to ten percent (10%) of the maximum value of the transient. The high

MIL-STD-1275E

threshold is defined to be the time when the amplitude is equal to ninety percent (90%) of the maximum value of the transient.

3.5.2 Fall time.

The fall time is the difference between when the falling edge of a voltage or current transient crosses a pre-defined high threshold to when the transient crosses a pre-defined low threshold. As defined in this standard, the high threshold is defined to be the time at when the amplitude of the falling edge is equal to ninety percent (90%) of the maximum value of the transient. The low threshold is defined to be the time when the amplitude is equal to ten percent (10%) of the maximum value of the transient.

3.5.3 Recovery time.

The interval between the time a characteristic deviates from the steady-state limits and the time it returns and remains within the same range. Refer to Figure 1.

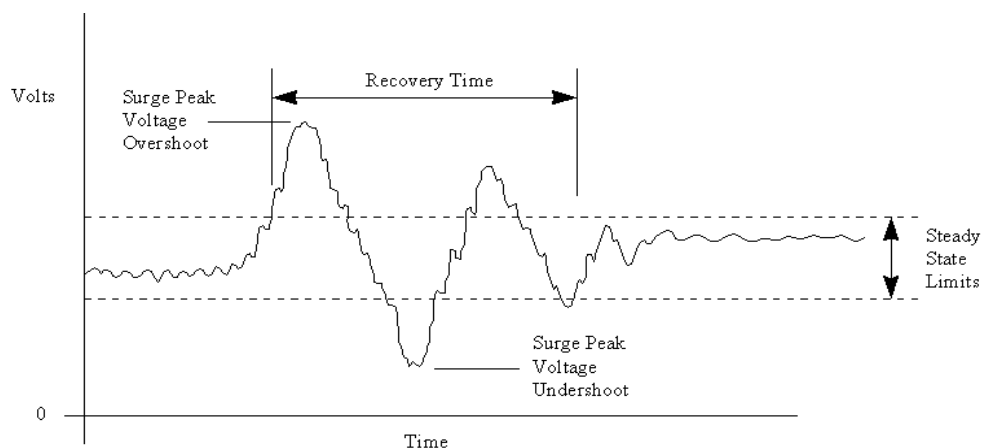

Figure 1. Recovery time.

3.5.4 Ripple.

The regular and/or irregular variations of voltage about a fixed DC voltage level during normal operation of a DC system.

3.6 Types of transient waveforms.

There are several different types of transient waveforms associated with the vehicle's power supply system.

3.6.1 Starting disturbance.

A starting disturbance is the variation in system voltage from the normal operating voltage range caused by the initial engagement of the engine starter and subsequent engine cranking. The duration of the Initial Engagement Surge (IES) is measured from the time at which it departs from the normal operating voltage to the time at which it reaches and remains at the cranking

MIL-STD-1275E

voltage. An example showing “Initial Engagement Surge” (IES) and “Cranking”; i.e., voltage level during active engine cranking is shown in Figure 2.

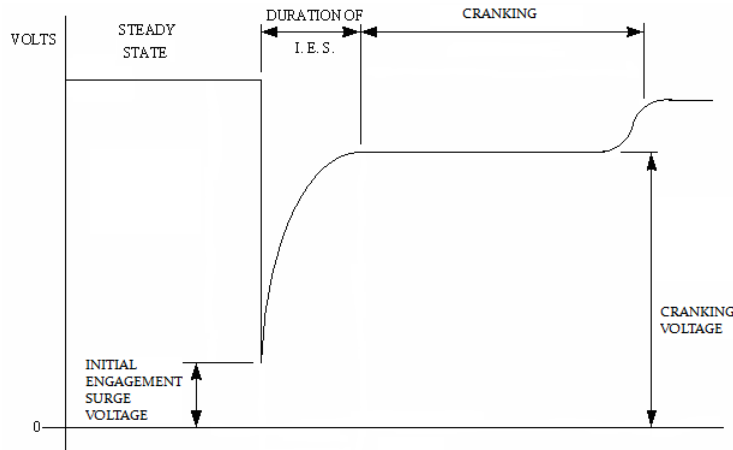

Figure 2. Sample starting disturbance waveform.

3.6.2 Voltage spike.

A voltage spike is an energy-limited transient waveform having a duration less than or equal to 1 ms. These typically result from the interaction of the power delivery system wiring and switching of reactive loads or a mismatch in impedance between the wiring harness and equipment. Figure 3 shows an example of a spike waveform.

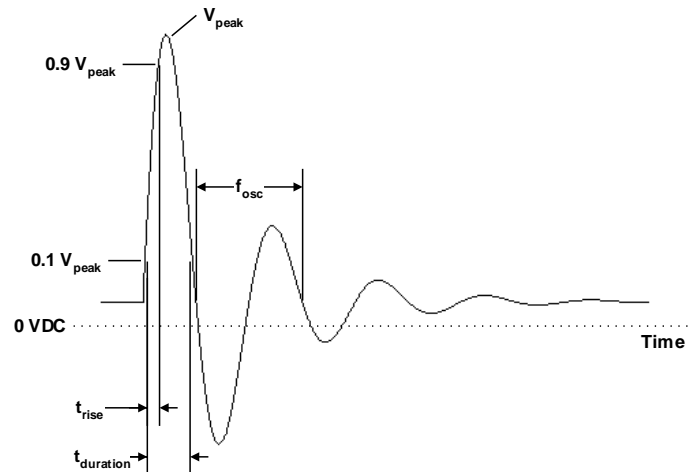

Figure 3. Voltage spike.

MIL-STD-1275E

3.6.3 Voltage surge.

A surge is a transient waveform having a duration greater than 1 ms and a specific wave shape, typically a rising/falling edge and a slow exponential decay for the falling edge. Surges result from the switching of reactive loads containing a significant level of stored energy or sudden disconnection of a constant load. Surges may also occur due to the application of high-demand loads.

3.6.3.1 Positive voltage surge.

A positive voltage surge is a positive-going transient, which exceeds the nominal supplied voltage. This may occur when a high current or inductive load is suddenly disconnected. The most common occurrence of a positive voltage surge, or “alternator load dump,” occurs when the alternator is working to charge a partially or fully discharged set of batteries and the connection to the battery positive terminal is suddenly disconnected. The alternator cannot immediately decrease its output to compensate for the sudden loss of load so the energy delivered during this settling period is distributed to the vehicle’s electrical system. A positive surge (V_{PEAK}) with a short rise time (t_{RISE}) and long exponential decay is generated above the nominal battery voltage of the system (V_{NOM}) and last for a given time (t_{WIDTH}). Figure 4 shows an example of an alternator load dump waveform.

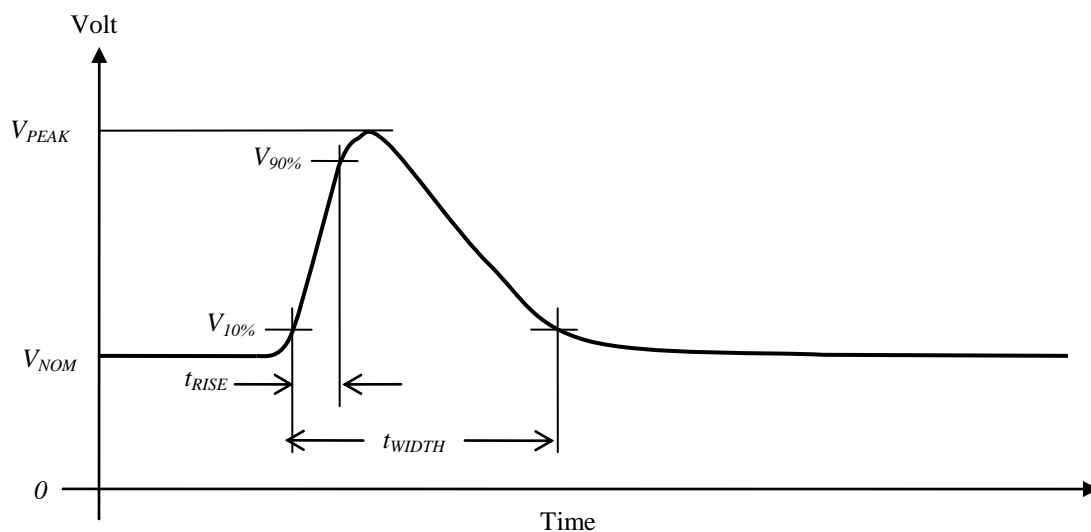

Figure 4. Sample alternator load dump waveform.

3.6.3.2 Negative voltage surge.

This event is similar to an alternator load dump as specified in Section 3.6.3.1 except it represents the negative-going transient generated when a sudden load is placed on the alternator. The alternator cannot immediately change its output so the system voltage decreases until the alternator can compensate for the sudden increase in load.

MIL-STD-1275E

3.6.4 Intermittent contact.

Intermittent contact occurs when electrical contacts in a switch or relay change state. A common way of describing intermittent contacts is the use of the terms “contact bounce” or “chattering relay.” Mechanical vibration may also affect the operation of mechanical contacts and cause this to occur. The settling period and pulse widths associated may vary depending on the construction of the contacts. Figure 5 shows an example of an intermittent contact waveform.

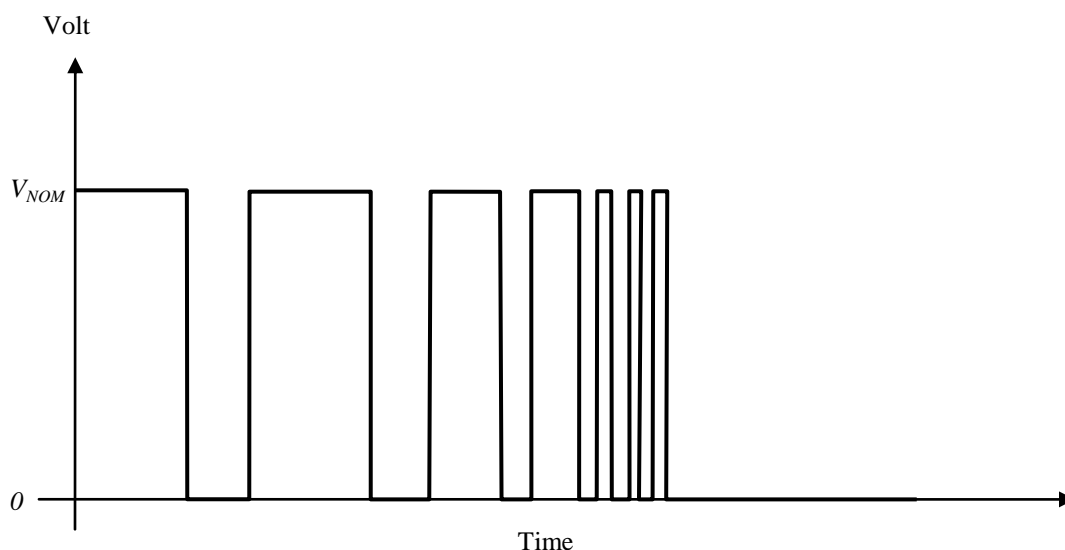

Figure 5. Sample intermittent contact waveform.

Intermittent contact may affect operation of equipment in one of two ways. First, equipment power feed(s) controlled by the relay/switch may be directly affected with resets, dropouts, etc. Second, the electrical noise generated by the intermittent contact on a directly connected wire may be coupled to nearby wires in the wiring harness through electric/magnetic field coupling.

3.7 Reverse polarity.

Reverse polarity is defined as the inverted connection of the EUT’s power terminal(s) to the vehicle’s power system. The positive (+) terminal of the EUT is connected to the negative (-) or “ground” terminal of the vehicle’s power supply system. The negative (-) terminal of the EUT is connected to the positive (+) terminal of the vehicle’s power supply system.

4 GENERAL REQUIREMENTS

4.1 Reverse polarity.

Utilization equipment shall protect itself against damage due to input power with reverse polarity. With reverse polarity voltage applied to the input power terminals of the utilization equipment, the magnitude of the reverse polarity input current shall be equal to or less than the magnitude of the utilization equipment normal operating current.

MIL-STD-1275E

4.2 Electromagnetic compatibility.

Utilization equipment shall be compatible with the applicable performance specification requirements for control of electromagnetic interference and voltage spikes induced by lightning, electromagnetic pulses, and power switching. Electromagnetic interference is not covered by this standard.

4.3 Electrostatic discharge.

Utilization equipment shall be compatible with the applicable performance specification requirements for immunity to electrostatic discharge. Electrostatic discharge is not covered by this standard.

5 DETAILED REQUIREMENTS

5.1 Voltage compatibility requirements.

This section contains detailed requirements regarding the voltage conditions under which the utilization equipment is expected to operate. Verification of compliance shall be in accordance with Sections 5.2 and 5.3 of this document.

5.1.1 Steady state operation.

This section describes the steady state voltage range, which excludes engine starting disturbances, and applies to all utilization equipment. Utilization equipment shall operate without degradation or damage when subjected to the operational voltage range specified in this section.

5.1.1.1 Operational voltage range.

The utilization equipment voltage operating range is between 20 VDC and 33 VDC, including ripple.

5.1.1.2 Voltage ripple.

The maximum peak-to-peak ripple voltage limits are specified in MIL-STD-461 CS101 with the same values used at 150 kHz extended to 250 kHz, as shown in Figure CS101-1.

5.1.2 Starting operation.

This section applies to utilization equipment operating while subjected to engine starting disturbances. Utilization equipment shall operate without degradation or damage when subjected to engine starting disturbances within the limits shown in Figure 6.

5.1.2.1 Initial engagement surge (IES).

The minimum voltage supplied to utilization equipment during an IES is 12 VDC. The maximum duration of the IES is one (1) second. Consecutive IES events are a minimum of one (1) second apart.

5.1.2.2 Cranking surges.

The minimum voltage supplied to utilization equipment during cranking surges is 16 VDC. The maximum duration of cranking surges is thirty (30) seconds.

MIL-STD-1275E

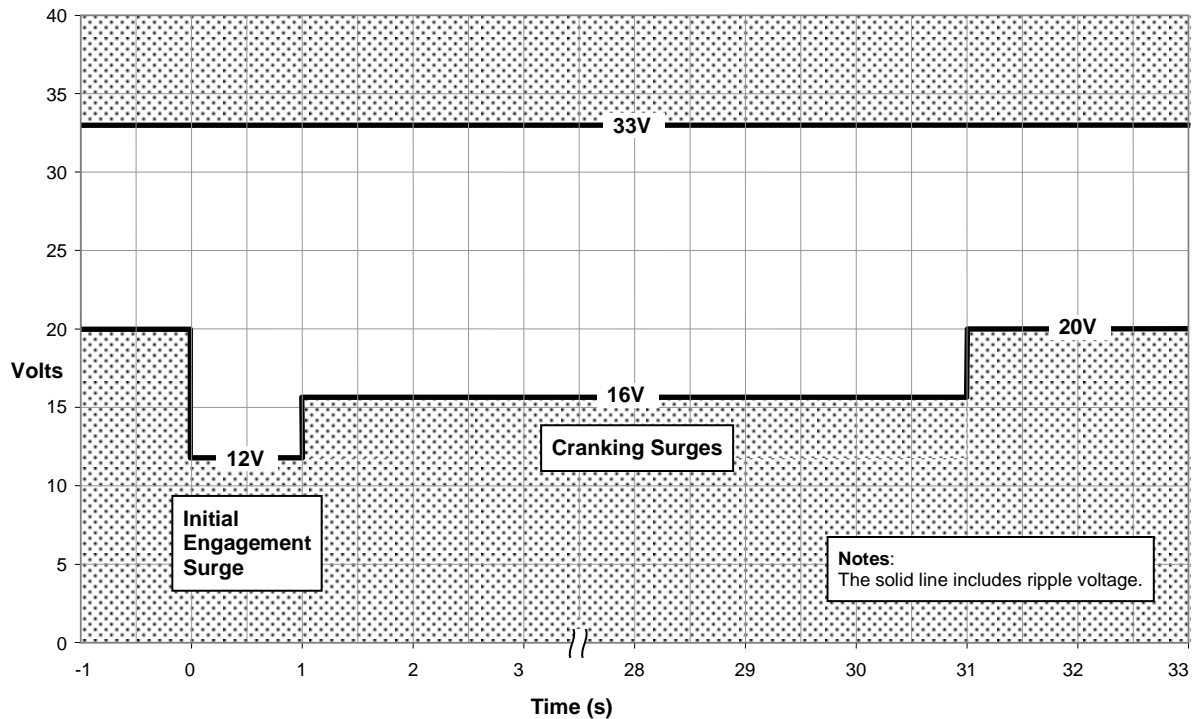

Figure 6. Starting disturbance limits on 28VDC systems.

5.1.3 Transient disturbances.

This section describes transient waveforms and applies to all utilization equipment.

5.1.3.1 Voltage spikes.

5.1.3.1.1 Injected voltage spikes.

Utilization equipment shall operate without degradation or damage when subjected to voltage spikes within the limits shown in Figure 7. The maximum rise time (t_{RISE}) of the injected spikes is 50 nanoseconds, and the maximum total energy content of a single spike is 2 Joules.

5.1.3.1.2 Emitted voltage spikes.

Emitted voltage spikes from utilization equipment shall be within the limits shown in Figure 7. The maximum total energy content of a single emitted spike is 125 millijoules (mJ).

5.1.3.2 Voltage surges.

5.1.3.2.1 Injected voltage surges.

Utilization equipment shall operate without degradation or damage when subjected to voltage surges within the limits shown in Figure 8. The maximum total energy content of a single surge is 60 Joules (J).

MIL-STD-1275E

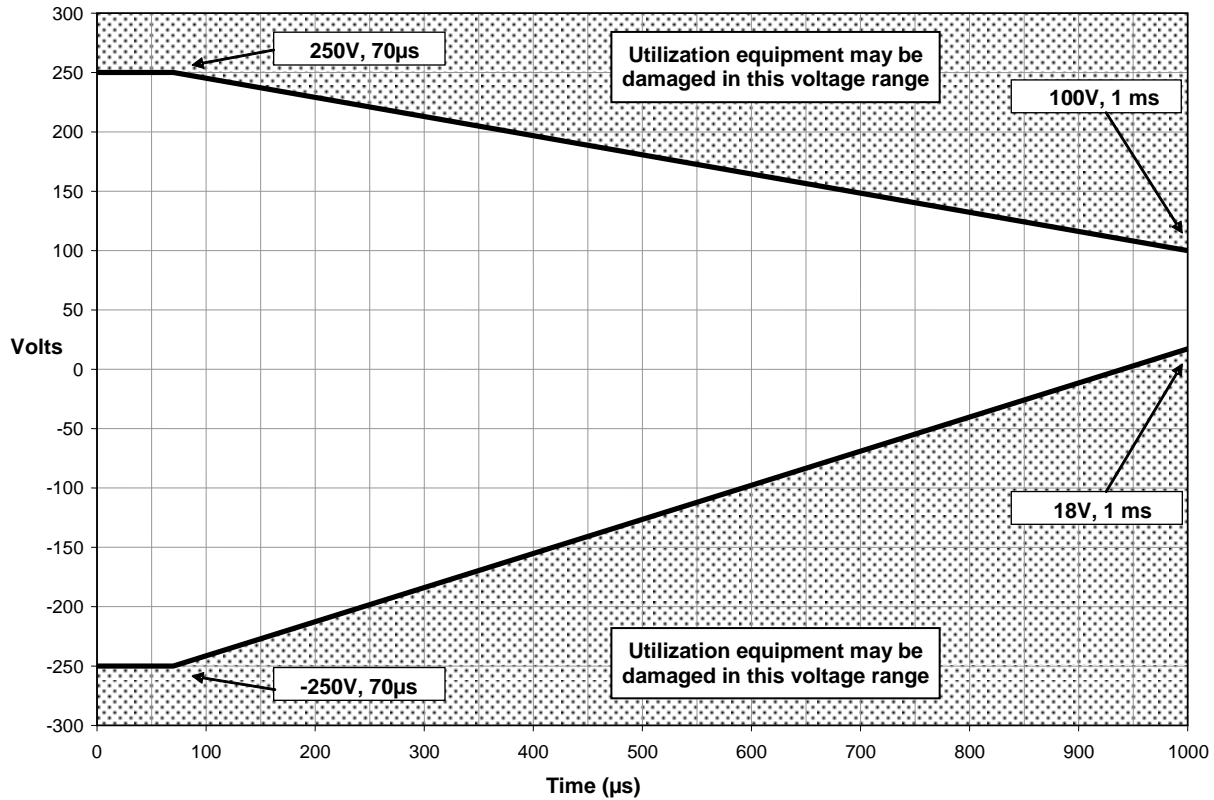

Figure 7. Envelope of spikes for 28VDC systems.

5.1.3.2.2 Emitted voltage surges.

Emitted voltage surges from utilization equipment shall be within the limits shown in Figure 8.

5.2 Voltage compatibility verification setup.

5.2.1 Environmental conditions.

Testing of the EUT according to this standard shall be performed under the following environmental conditions:

Temperature:	+23°C ± 5°C (+73°F ± 9°F)
Relative Humidity:	0% to 90% humidity
Atmospheric Pressure:	80kPa to 102kPa (23.62 inHg to 30.12 inHg)

Testing under different environmental conditions (e.g., extremes of operating temperature) shall be conducted at the discretion of the appropriate authority.

The electromagnetic environment (e.g., background noise) shall not interfere with the measurement instrumentation setup.

MIL-STD-1275E

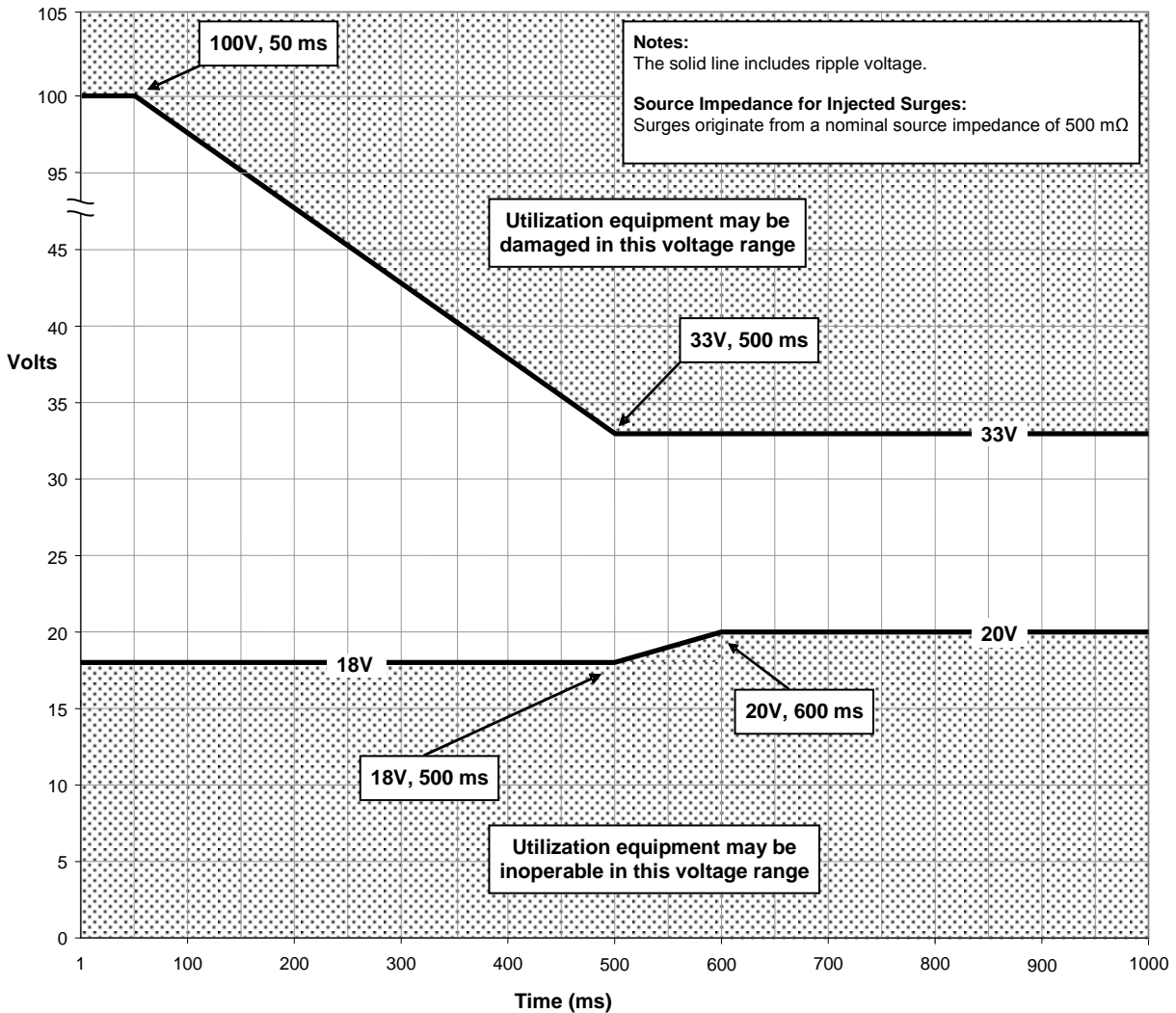

Figure 8. Envelope of surges for 28VDC systems.

5.2.2 Calibration of test equipment.

Test equipment used to verify parameters such as current, voltage, rise/fall time, etc. of the test setup shall have traceable calibration to a national standards body, such as NIST, and within the calibration period at the time of the test.

5.2.3 Nominal voltage.

For purposes of verification, the term “nominal” when used to describe voltage shall mean the stated voltage $\pm 1\%$, unless otherwise stated.

5.2.4 Measurement tolerance.

The default measurement tolerance shall be $\pm 1\%$ unless otherwise stated.

MIL-STD-1275E

5.2.5 Measurement reference point.

The measurement reference point for EUTs shall be the power input terminals of the EUT. EUTs having multiple power input terminals shall be individually and simultaneously monitored during the test(s). All transient voltage waveforms applied to EUTs shall be verified open circuit; i.e., no load.

5.2.6 Power return.

The test setup shall use a power return for the EUT as required by the applicable performance specification.

If a power return is not specified, the EUT power return conductor shall be equivalent to the EUT power source conductor.

In cases where the EUT uses the vehicle structure as the power return, a ground plane in accordance with (IAW) MIL-STD-461 shall be used to simulate the vehicle's metal structure as the return current path. The negative (-) terminal of the EUT as well as the negative (-) terminal of the power source shall be bonded to the ground plane.

5.2.7 Loads.

Loads representative of the actual installation on vehicle shall be used to test the EUT if the EUT is not a standalone device.

5.2.8 Power supply.

Power supplies shall maintain $\pm 1\%$ of specified voltage during testing, as measured at their output.

5.3 Voltage compatibility verification method.

5.3.1 Steady state operation.

5.3.1.1 Operational voltage range.

The EUT shall be tested to operate as specified while subjected to the voltages/durations at both the lower and higher limits of the voltage envelope shown in Figure 8. Any deviation from normal operation shall be recognized as a failure of the EUT.

5.3.1.2 Voltage ripple.

Unless otherwise specified in the applicable performance specification, the test method and limits for voltage ripple specified in MIL-STD-461 CS101 shall be used at nominal voltages of 23 VDC and 30 VDC with the same values used at 150 kHz extended to 250 kHz, as shown in Figures CS101-1 and CS101-2.

Verify the EUT operates as specified while subjected to the ripple. Any deviation from normal operation shall be recognized as a failure of the EUT.

MIL-STD-1275E

5.3.2 Starting operation.

When applicable, the EUT shall be tested to operate as specified while subjected to the voltages/durations of the lower limit of the voltage envelope shown in Figure 6. Any deviation from normal operation shall be recognized as a failure of the EUT.

5.3.3 Transient disturbances.5.3.3.1 Voltage spikes.5.3.3.1.1 Injected voltage spikes.

The EUT shall be supplied power by a voltage source set to the nominal 28 VDC operating voltage through a Line Impedance Stabilization Network (LISN). The test operator shall inject voltage spikes into the EUT using a test setup similar to Figure 9.

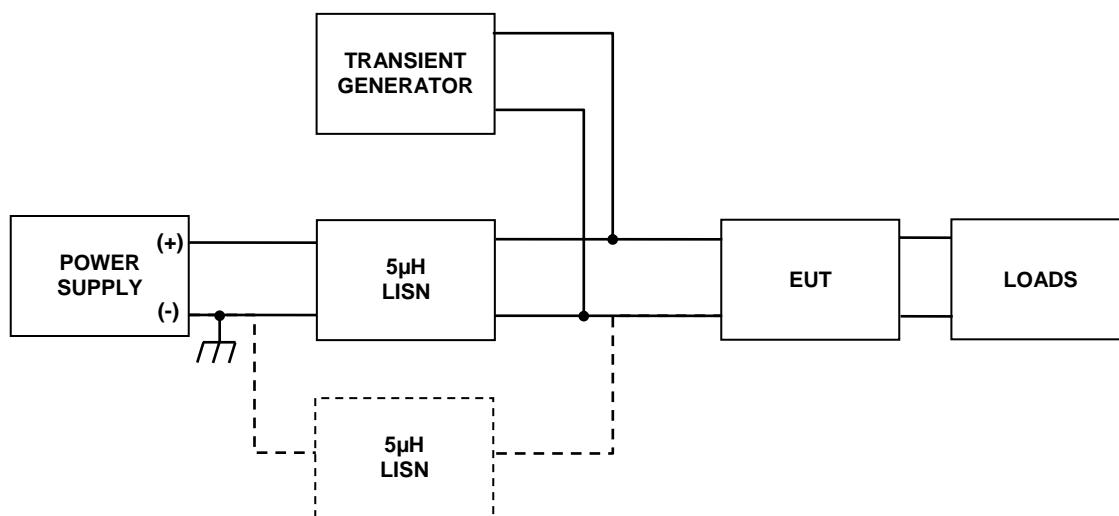

Figure 9. Sample test setup for immunity to injected voltage spikes.

One LISN shall be used when the power return is the vehicle chassis; in this case the ground plane provides the power return current path. Two LISNs shall be used when the EUT has a dedicated power return conductor, such as wires, buss bar, etc. This simulates the additional vehicle wiring harness present in the vehicle.

Both positive and negative voltage spikes shall be applied to the EUT. A minimum of fifty (50) 250V spikes of each polarity shall be applied at one (1) second intervals. Each test spike shall have a peak amplitude of 250V, a risetime not exceeding 50 ns, a frequency of oscillation greater than 100 kHz and less than 500 kHz, and a maximum energy content of 2 Joules.

Verify the EUT operates as specified while subjected to the voltage spikes. Any deviation from normal operation shall be recognized as a failure of the EUT.

MIL-STD-1275E

5.3.3.1.2 Emitted spikes.

The EUT shall be supplied power by a source set to the nominal 28 VDC operating voltage. Unless otherwise specified in the applicable performance specification, use the conducted transient emissions test method specified in SAE J1113-42 to measure the spikes emitted by the EUT using a test setup similar to Figure .

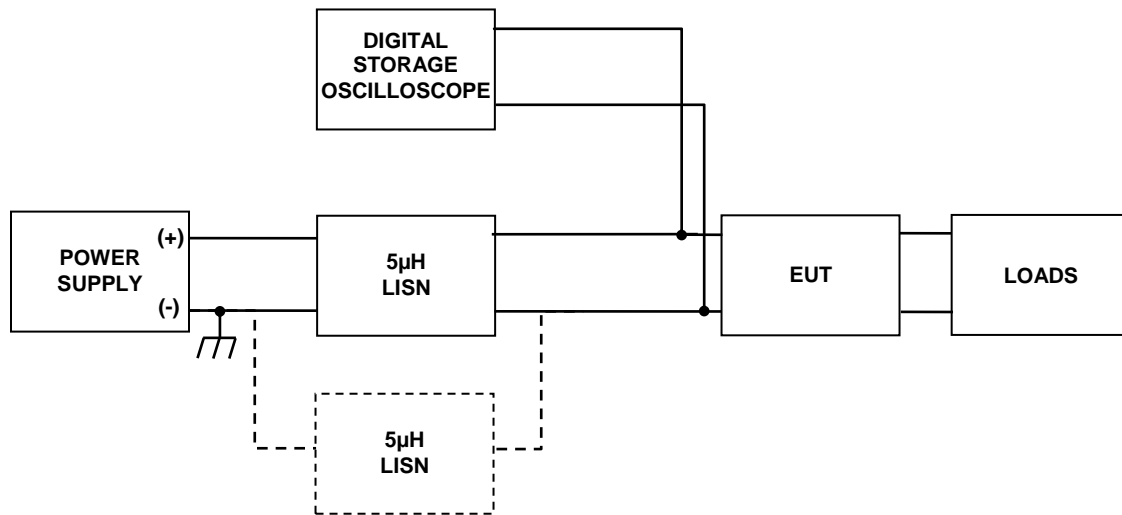

Figure 10. Sample test setup for exported voltage spikes and surges.

One LISN shall be used when the power return is the vehicle chassis; in this case the ground plane provides the power return current path. Two LISNs shall be used when the EUT has a dedicated power return conductor, such as wires, buss bar, etc. This simulates the additional vehicle wiring harness present in the vehicle.

The test operator shall exercise switching function(s) of the EUT capable of producing spikes, (e.g., the switching of any inductive loads controlled by the EUT). If the power source to the EUT is controlled by means of a vehicle mounted switch or relay, the test shall be performed using this switch or relay. Each switching function shall be exercised a minimum of thirty-two (32) times in order to give a reasonable probability that the maximum spike voltage is recorded. The test operator shall monitor the operation of the EUT. Voltage spikes emitted by the EUT shall be within the limits shown in Figure 7. Any voltage spike or combination of voltage spikes emitted from a single event shall have an energy content less than 125 mJ.

5.3.3.2 Voltage surges.5.3.3.2.1 Injected voltage surges.

The test operator shall inject voltage surges into the EUT using a test setup similar to Figure 11.

MIL-STD-1275E

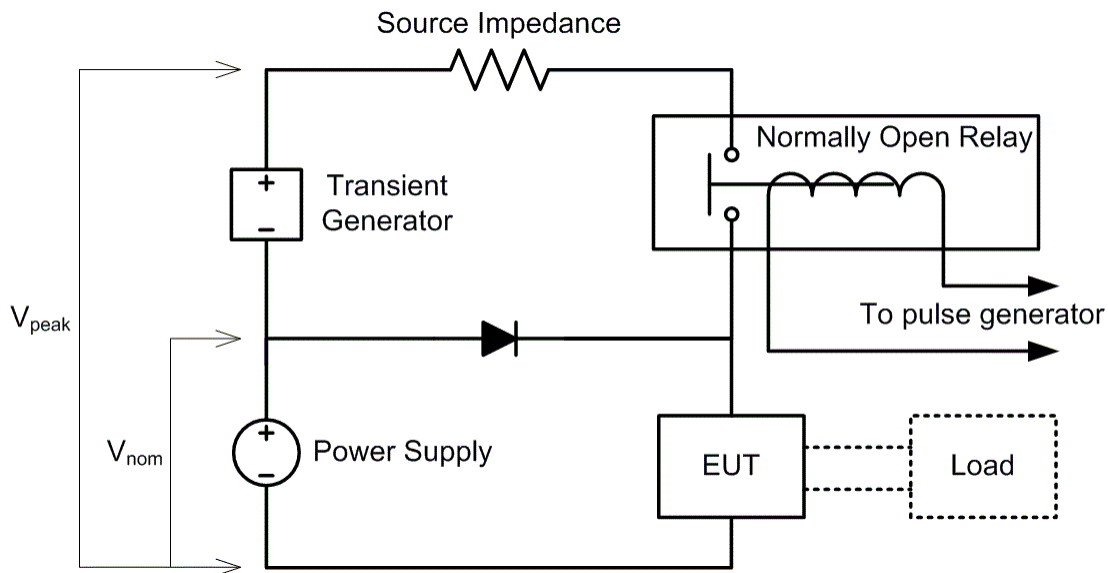

Figure 11. Sample test circuit for immunity to injected voltage surges.

The voltage waveform injected on the power line(s) of the EUT shall simulate the voltage surge shown in Figure 4. The voltage surge parameters are shown in Table I. Energy emitted from the transient surge generator shall be limited to 60 Joules.

Table I. Positive voltage surge test parameters.

Operating Voltage (V_{nom})	Amplitude (V_{peak})	Rise Time (ms)	Duration (ms)	Source Impedance ($m\Omega$)	Number of Pulses	Time Between Pulses (s)
30 -0/+1	100 -0/+10	$1 < t < 10$	50 -0/+5	500 -25/+0	5	5

Prior to connection of the EUT, the test operator shall verify the amplitude and duration of the voltage surge specified in Table I with a non-inductive load whose resistance is matched to the source impedance of the transient generator.

Verify the EUT operates as specified while subjected to the voltage surges. Any deviation from normal operation shall be recognized as a failure of the EUT.

5.3.3.2.2 Emitted voltage surges.

The EUT shall be supplied power by a source set to the nominal 28 VDC operating voltage. The test operator shall measure voltage surges emitted by the EUT using a test setup similar to Figure 10. The test operator shall exercise function(s) of the EUT capable of producing surges. Each surge-producing function shall be exercised a minimum of thirty-two (32) times in order to give a reasonable probability that the maximum surge voltage is recorded.

MIL-STD-1275E

The test operator shall monitor the operation of the EUT. Voltage surges emitted by the EUT shall be within the limits shown in Figure 8.

5.3.4 Reverse polarity.

Connect the positive (+) terminal of the EUT to the negative (-) terminal of the power supply system. Connect the negative (-) terminal of the EUT to the positive (+) terminal of the power supply system. Set the voltage on the power supply to 33 VDC and leave connected for five (5) minutes. Connect EUT input terminals to power with the correct polarity and verify device operates as specified. Any deviation from normal operation shall be recognized as a failure of the EUT.

5.3.5 Electromagnetic compatibility.

The EUT shall demonstrate compliance with the applicable performance specification requirements for control of electromagnetic interference and voltage spikes induced by lightning, electromagnetic pulses, and power switching prior to MIL-STD-1275 testing. Electromagnetic interference testing is not covered by this standard.

5.3.6 Electrostatic discharge.

The EUT shall demonstrate compliance with the applicable performance specification requirements for immunity to electrostatic discharge prior to MIL-STD-1275 testing. Electrostatic discharge testing is not covered by this standard.

6 NOTES

(This section contains information of a general or explanatory nature, which may be helpful, but is not mandatory.)

6.1 Intended use.

The intent of this document is to describe the nominal 28 VDC voltage characteristics, common across military ground vehicles, at the input power terminal of the utilizing electrical and electronic assemblies directly connected to the distribution network. This lays the groundwork for commonality across vehicle platforms. The vehicle's design authority is responsible to ensure that the 28 VDC delivered to the input power terminal of the utilization equipment meets these requirements.

6.2 Acronyms.

Acronym	Definition
EUT	Equipment Under Test
IAW	In Accordance With
IES	Initial Engagement Surge
LISN	Line Impedance Stabilization Network
NIST	National Institute of Standards and Technology
SAE	Society of Automotive Engineers

MIL-STD-1275E

6.3 International interest.

Certain provisions of this standard are the subject of international standardization agreement NATO STANAG 2601. When a change notice, revision, or cancellation of this standard is proposed which will modify the international agreement concerned, the preparing activity will take appropriate action through international standardization channels, including departmental standardization offices, to change the agreement or make other appropriate accommodations.

6.4 Changes from previous issue.

Marginal notations are not used in this revision to identify changes with respect to the previous issue due to the extent of the changes.

6.5 Subject term (key word) listing.

- Polarity
- Recovery time
- Ripple
- Rise time
- Spike
- Starting disturbance
- Surge
- Voltage

Custodian:
Army – AT

Preparing Activity:
Army - AT

Review Activities:
Army - CR, MI, TE
DLA - CC

Project 2920-2013-001

NOTE: The activities listed above were interested in this document as of the date of this document. Since organizations and responsibilities can change, you should verify the currency of the information above using the ASSIST Online, database at <https://assist.dla.mil>.