



Errata

Title & Document Type: 4193A Vector Impedance Meter Operation and Service Manual

Manual Part Number: 04193-90000

Revision Date: August 1, 1983

HP References in this Manual

This manual may contain references to HP or Hewlett-Packard. Please note that Hewlett-Packard's former test and measurement, semiconductor products and chemical analysis businesses are now part of Agilent Technologies. We have made no changes to this manual copy. The HP XXXX referred to in this document is now the Agilent XXXX. For example, model number HP8648A is now model number Agilent 8648A.

About this Manual

We've added this manual to the Agilent website in an effort to help you support your product. This manual provides the best information we could find. It may be incomplete or contain dated information, and the scan quality may not be ideal. If we find a better copy in the future, we will add it to the Agilent website.

Support for Your Product

Agilent no longer sells or supports this product. You will find any other available product information on the Agilent Test & Measurement website:

www.tm.agilent.com

Search for the model number of this product, and the resulting product page will guide you to any available information. Our service centers may be able to perform calibration if no repair parts are needed, but no other support from Agilent is available.



OPERATION AND SERVICE MANUAL

MODEL 4193A

VECTOR IMPEDANCE METER

SERIAL NUMBERS

This manual applies directly to instruments with serial numbers prefixed 2206J.

With changes described in Section VII, this manual also applies to instruments with serial numbers prefixed 2136J.

For additional important information about serial numbers, see **INSTRUMENTS COVERED BY MANUAL** in Section I.

© COPYRIGHT: YOKOGAWA-HEWLETT-PACKARD, LTD., 1983
9-1, TAKAKURA-CHO, HACHIOJI-SHI, TOKYO, JAPAN

Table of Contents

TABLE OF CONTENTS

Section	Title	Page	Section	Title	Page
I	GENERAL INFORMATION		3-36.	Use of Furnished Probe Adapters	3-13
1-1.	Introduction	1-1	3-39.	Probe	3-13
1-4.	Description	1-1	3-41.	Probe and Test Fixture Residuals	3-14
1-10.	Specifications	1-2	3-45.	External Oscillator	3-15
1-12.	Safety Considerations	1-2	3-47.	X-Y Recorder Output	3-15
1-15.	Instruments Covered by Manual	1-2	3-49.	Analog Magnitude Output ...	3-15
1-20.	Options	1-3	3-51.	Analog Phase Output	3-15
1-22.	Accessories Supplied	1-3	3-53.	Analog Frequency Output ...	3-15
1-24.	Accessories Available	1-3	3-55.	HP-IB Compatibility	3-20
			3-57.	HP-IB Interface Capabilities	3-20
II	INSTALLATION		3-59.	Connection to HP-IB	3-20
2-1.	Introduction	2-1	3-61.	HP-IB Control Switch	3-20
2-3.	Initial Inspection	2-1	3-63.	Addressable Mode	3-20
2-5.	Preparation for Use	2-1	3-65.	Talk Only Mode	3-21
2-6.	Power Requirements	2-1	3-67.	HP-IB Status Indicators ...	3-22
2-8.	Line Voltage and Fuse Selection	2-1	3-69.	Local Key	3-22
2-10.	Power Cable	2-1	3-71.	Data Output	3-22
2-14.	Operating Environment	2-2	3-73.	Output Data Format	3-23
2-17.	Installation Instructions	2-2	3-75.	Programming Guide for the 4193A	3-23
2-19.	Installation of Options 907, 908 and 909	2-2	3-77.	Service Request Status Byte	3-23
2-21.	Storage and Shipment	2-2	3-79.	Parameter Setting	3-24
2-22.	Environment	2-2			
2-24.	Packaging	2-4	IV	PERFORMANCE TESTS	
III	OPERATION		4-1.	Introduction	4-1
3-1.	Introduction	3-1	4-3.	Equipment Required	4-1
3-3.	Operating Instructions	3-1	4-5.	Test Record	4-1
3-5.	Panel Features	3-1	4-7.	Calibration Cycle	4-1
3-7.	Self Test	3-1	4-9.	Initial Operation Check ...	4-2
3-9.	Initial Control Settings	3-7	4-10.	Test Frequency Accuracy Test	4-3
3-11.	Measurement Range	3-7	4-11.	Test Signal Level Test	4-4
3-13.	Test Signal Level	3-7	4-12.	Impedance Accuracy Test ...	4-5
3-15.	Test Frequency	3-7	4-13.	External Oscillator Usage Check	4-7
3-17.	Swept Frequency Measurements	3-7	4-14.	Recorder Output Voltage Accuracy Test	4-8
3-19.	Partial Sweep Measurement	3-7	4-15.	HP-IB Interface Test	4-9
3-21.	Full Sweep Measurement	3-7	V	ADJUSTMENTS	
3-23.	Displays	3-11	5-1.	Introduction	5-1
3-28.	Error-Codes and Over-range Annunciations	3-11	5-3.	Safety Requirements	5-1
3-30.	Initial Display Test	3-11	5-7.	Equipment Required	5-1
3-32.	External Triggering	3-13	5-9.	Factory Selected Components	5-1
3-34.	Measurement Time	3-13			

TABLE OF CONTENTS

Section	Title	Page	Section	Title	Page
5-11.	Adjustment Relationships	5-2	VII	MANUAL CHANGES	
5-13.	Adjustment Locations	5-2	7-1.	Introduction	7-1
5-15.	Initial Operating Procedure	5-2	7-3.	Manual Changes	7-1
5-17.	Extrusion Board Removal ...	5-2	VIII	SERVICE	
5-19.	Board Extension	5-2	8-1.	Introduction	8-1
5-21.	100MHz Reference Frequency Adjustment (A8)	5-4	8-3.	Safety Considerations	8-1
5-22.	300MHz BPF Adjustment (A8)	5-4	8-5.	Theory of Operation	8-1
5-23.	300MHz Output Level Adjustment (A8)	5-6	8-7.	Recommended Test Equipment	8-1
5-24.	Integrator Offset Adjustment (A11)	5-7	8-9.	Troubleshooting	8-1
5-25.	VCXO Adjustment (A6)	5-8	8-11.	Repair	8-1
5-26.	BPF Output Level Adjustment (A6)	5-9	8-13.	Basic Theory	8-2
5-27.	A2 Output Amplifier Bias Adjustment (A2)	5-10	8-15.	Analog Section Block Diagram Discussion	8-4
5-28.	Sampling Pulse Height Adjustment (A1)	5-11	8-17.	Signal Source Block	8-4
5-29.	ALC Reference Voltage Adjustment (A13)	5-15	8-19.	A2 ALC Amplifier	8-4
5-30.	IF BPF Gain/Phase Adjustment (A12)	5-16	8-21.	A7 Divider	8-4
5-31.	I Channel Sampling Diode Bias Adjustment (A4) ...	5-17	8-23.	A8 Crystal Oscillator	8-4
5-32.	Test Signal Level Adjustment (A4)	5-18	8-25.	A9 Mixer	8-4
5-33.	V Channel Sampling Diode Bias Adjustment (A3) ...	5-18	8-27.	A10 Voltage Controlled Oscillator	8-4
5-34.	Magnitude and Phase Accuracy Adjustment (A3/A4/A41)	5-19	8-29.	A11 Integrator	8-5
5-35.	Recorder Output Voltage Adjustment (A15)	5-20	8-31.	Sampling Block	8-8
VI	REPLACEABLE PARTS		8-34.	A1 Samplig Pulse Generator	8-8
6-1.	Introduction	6-1	8-36.	A51 Probe I-Channel	8-8
6-3.	Abbreviations	6-1	8-38.	A52 Probe V-Channel	8-8
6-5.	Replaceable Parts List	6-1	8-40.	A5 Mixer/Divider	8-8
6-7.	Ordering Information	6-2	8-42.	A6 Voltage Controlled Crystal Oscillator	8-9
6-10.	Spare Parts Kit	6-2	8-44.	Detection Block	8-12
6-12.	Direct Mail Order System	6-2	8-46.	A3 IF V-Channel Amplifier .	8-12
			8-48.	A4 IF I-Channel Amplifier .	8-12
			8-50.	A12 IF BPF	8-12
			8-52.	A13 Detector	8-12
			8-54.	A14 ADC	8-13
			8-56.	Digital Section Block Diagram Discussion	8-14
			8-58.	A15 Analog Output	8-14
			8-60.	A16 HP-IB	8-14
			8-62.	A17 Control Logic	8-14
			8-64.	A18 Display/Key Control ...	8-15
			8-66.	Overall Measurement Sequence	8-16
			8-76.	Timing Diagram Discussion ..	8-17
			8-81.	Probe Repair	8-18
			8-86.	Probe Assembly	8-19
			8-88.	Adjustment Related to Probe Replacement and Repair .	8-19
			8-90.	Frequency Characteristics Adjustment	8-19

List of Tables

LIST OF TABLES

Number	Title	Page	Number	Title	Page
1-1.	Specifications	1-4	6-1.	List of Reference Designators and Abbreviations	6-1
1-2.	General Information	1-9	6-2.	Manufacturers Code Lists	6-2
1-3.	Probe Kit for 4193A	1-10	6-3.	Replaceable Parts	6-3
1-4.	Accessories Available	1-11	6-4.	Parts Identification	6-42
3-1.	Measurement Range and Test Signal Level	3-7	6-5.	Cables on Extrusion Boards ...	6-47
3-2.	Test Frequency Range	3-7	7-1.	Manual Changes by Serial Number	7-1
3-3.	Operational Error-codes	3-11	8-1.	I/O Group Functions	8-16
3-4.	Annunciations	3-12	8-2.	Address Assignments	8-16
3-5.	SELF TEST Error-codes	3-12	8-3.	Mnemonic Information	8-22
3-6.	External Trigger Pulse	3-13			
3-7.	Furnished Probe Adapters	3-13			
3-8.	Typical Residuals at 100MHz ..	3-14			
3-9.	HP-IB Interface Capabilities .	3-20			
3-10.	Functions of Bit Switches ① through ⑥	3-21			
3-11.	Output Data Format	3-23			
3-12.	REMOTE PROGRAM CODE	3-25			
4-1.	Recommended Test Equipment ...	4-0			
4-2.	Test Frequency Accuracy Test Limits	4-3			
4-3.	Test Signal Level Test Limits	4-4			
4-4.	Impedance Accuracy Test Limits for 10Ω	4-5			
4-5.	Impedance Accuracy Test Limits for 100Ω	4-6			
4-6.	Impedance Accuracy Test Limits for 1kΩ	4-6			
4-7.	Impedance Accuracy Test Limits for 10kΩ	4-6			
4-8.	Impedance Accuracy Test Limits for 5pF	4-6			
4-9.	Recorder-output Voltage Limits	4-8			
4-10.	Controller Instructions and Operator Responses for Test Program 1	4-11			
4-11.	Controller Instructions and Operator Responses for Test Program 2	4-13			
4-12.	Controller Instructions and Operator Responses for Test Program 3	4-15			
5-1.	Adjustable Components	5-0			
5-2.	Factory Selected Components ..	5-3			
5-3.	Adjustment Requirements	5-3			

LIST OF ILLUSTRATIONS

Number	Title	Page	Number	Title	Page
1-1.	Model 4193A and Accessories ..	1-1	5-5.	Integrator Offset Adjustment Setup	5-7
1-2.	Serial Number Plate	1-2	5-6.	VCXO Adjustment Setup	5-8
2-1.	Voltage and Fuse Selection ...	2-2	5-7.	BPF Output Level Adjustment Setup	5-9
2-2.	Power Cables Supplied	2-3	5-8.	A2 Output Amplifier Bias Adjustment Setup	5-10
2-3.	Rack Mount Kit	2-4	5-9.	Sampling Pulse Height Adjustment Setup	5-11
3-1.	Front Panel Features	3-2	5-10.	Scope Displays	5-13
3-2.	Rear Panel Features	3-6	5-11.	ALC Reference Voltage Adjustment Setup	5-15
3-3.	Spot Frequency Setting Procedure	3-8	5-12.	IF BPF GAIN/PHASE Adjustment Setup	5-16
3-4.	PARTIAL Sweep Measurement	3-9	5-13.	I Channel Sampling Diode DC Bias Adjustment Setup	5-17
3-5.	FULL Sweep Measurement	3-10	5-14.	Drive Current Level Adjustment Setup	5-18
3-6.	External Trigger Pulse	3-13	5-15.	V Channel Sampling Diode DC Bias Adjustment Setup	5-18
3-7.	Probe Socket Usage	3-13	5-16.	Magnitude and Phase Accuracy Adjustment Setup	5-19
3-8.	Equivalent Circuit	3-14	5-17.	Recorder Output Voltage Adjustment Setup	5-20
3-9.	Residuals Compensation	3-14	6-1.	Exploded View of Probe Assembly	6-45
3-10.	In-circuit Impedance Measurement Procedure	3-16	6-2.	Top View of Extrusion Boards ..	6-46
3-11.	General Component Measurement Procedure	3-17	8-1.	Basic Block Diagram	8-2
3-12.	External Oscillator Usage Procedure	3-18	8-2.	Relation between Z , V_v , and V_1 ..	8-3
3-13.	X-Y Recorder Usage Procedure ..	3-19	8-3.	Measurement Cycle	8-3
3-14.	HP-IB Control Switch	3-20	8-4.	Signal Source Block Diagram ..	8-5
3-15.	ADDRESSABLE Mode	3-20	8-5.	Signal Source Operation	8-6
3-16.	TALK ONLY Mode	3-21	8-6.	Sampling Block Diagram	8-9
3-17.	Status Byte	3-24	8-7.	Sampling Pulse Generation	8-10
3-18.	HP-IB Connector	3-26	8-8.	Sampling Pulses	8-11
3-19.	Sample Program 1	3-27	8-9.	Detection Block Diagram	8-13
3-20.	Sample Program 2	3-28	8-10.	Analog Section Block Diagram ..	8-13
4-1.	Initial Operation Check Setup	4-2	8-11.	Digital Section Block Diagram ..	8-15
4-2.	Test Frequency Accuracy Test Setup	4-3	8-12.	Measurement Sequence Flow Diagram	8-16
4-3.	Test Signal Level Test Setup ..	4-4	8-13.	I/OG Lines	8-16
4-4.	Impedance Accuracy Test Setup	4-5	8-14.	Integrator Output	8-17
4-5.	External Oscillator Usage Check Setup	4-7	8-15.	Timing Diagram	8-17
4-6.	Recorder-output Voltage Accuracy Test Setup	4-8	8-16.	Probe	8-18
4-7.	HP-IB Interface Test Setup ...	4-9	8-17.	Probe Assembly	8-18
5-1.	100MHz Reference Frequency Adjustment Setup	5-4	8-18.	Frequency Characteristics Adjustment	8-20
5-2.	300MHz BPF Adjustment Setup ..	5-5	8-19.	Assembly Locations	8-24
5-3.	300MHz Level	5-6			
5-4.	300MHz Level	5-6			

LIST OF ILLUSTRATIONS

Number	Title	Page	Number	Title	Page
8-20.	Schematic Diagram Notes	8-25	8-45.	A7 Divider Board Assembly Schematic Diagram	8-75
8-21.	Board Isolation Flow Chart ...	8-27	8-46.	A8 Crystal Oscillator Board Assembly Component Locations	8-77
8-22.	Signal Source Not Ready Flow Chart	8-31	8-47.	A8 Crystal Oscillator Board Assembly Schematic Diagram	8-77
8-23.	ALC Not Ready Flow Chart	8-35	8-48.	A9 Mixer Board Assembly Component Locations	8-81
8-24.	A1 Board Troubleshooting Flow Chart	8-39	8-49.	A9 Mixer Board Assembly Schematic Diagram	8-81
8-25.	A1 Sampling Pulse Generator Board Assembly Component Locations	8-41	8-50.	A10 Voltage Controlled Oscillator Board Assembly Component Locations	8-85
8-26.	A1 Sampling Pulse Generator/ A41 Delay Board Assembly Schematic Diagram	8-41	8-51.	A10 Voltage Controlled Oscillator Board Assembly Schematic Diagram	8-85
8-27.	A2 Board Troubleshooting Flow Chart	8-45	8-52.	A11 Integrator Amplifier Board Assembly Component Locations	8-89
8-28.	A2 ALC Amplifier Board Assembly Component Locations	8-47	8-53.	A11 Integrator Amplifier Board Assembly Schematic Diagram	8-89
8-29.	A2 ALC Amplifier Board Assembly Schematic Diagram	8-47	8-54.	A12 Board Troubleshooting Flow Chart	8-93
8-30.	A3 Board Troubleshooting Flow Chart	8-51	8-55.	A12 IF BPF Board Assembly Component Locations	8-95
8-31.	A3 V-Channel Amplifier Board Assembly Component Locations	8-53	8-56.	A12 IF BPF Board Assembly Schematic Diagram	8-95
8-32.	A52 Probe V-Channel Board Assembly Component Locations	8-53	8-57.	A13 Board Troubleshooting Flow Chart	8-99
8-33.	A3 V-Channel Amplifier/A52 Probe V-Channel Board Assembly Schematic Diagram	8-53	8-58.	A13 Detector Board Assembly Component Locations	8-101
8-34.	A4 Board Troubleshooting Flow Chart	8-57	8-59.	A13 Detector Board Assembly Schematic Diagram	8-101
8-35.	A4 I-Channel Amplifier Board Assembly Component Locations	8-59	8-60.	A14 Board Troubleshooting Flow Chart	8-105
8-36.	A51 Probe I-Channel Board Assembly Component Locations	8-59	8-61.	A14 ADC Board Assembly Component Locations	8-107
8-37.	A4 I-Channel Amplifier/A51 Probe I-Channel Board Assembly Schematic Diagram	8-59	8-62.	A14 ADC Board Assembly Schematic Diagram	8-107
8-38.	A5 Board Troubleshooting Flow Chart	8-63	8-63.	A15 Board Troubleshooting Flow Chart	8-113
8-39.	A5 Mixer and Divider Board Assembly Component Locations	8-65	8-64.	A15 Analog Output Board Assembly Component Locations	8-115
8-40.	A5 Mixer and Divider Board Assembly Schematic Diagram	8-65	8-65.	A15 Analog Output Board Assembly Schematic Diagram	8-115
8-41.	A6 Board Troubleshooting Flow Chart	8-67	8-66.	A16 Board Troubleshooting Flow Chart	8-117
8-42.	A6 Voltage Controlled Crystal Oscillator Board Assembly Component Locations	8-69	8-67.	A16 HP-IB Board Assembly Component Locations	8-119
8-43.	A6 Voltage Controlled Crystal Oscillator Board Assembly Schematic Diagram	8-69	8-68.	A16 HP-IB Board Assembly Schematic Diagram	8-119
8-44.	A7 Divider Board Assembly Component Locations	8-75	8-69.	A17 Board Troubleshooting Flow Chart	8-121

LIST OF ILLUSTRATIONS

Number	Title	Page
8-70.	A17 Control Logic Board Assembly Component Locations	8-123
8-71.	A17 Control Logic Board Assembly Schematic Diagram	8-123
8-72.	A18 Board Troubleshooting Flow Chart	8-127
8-73.	A18 Display Board Assembly Component Locations	8-129
8-74.	A18 Display Board Assembly Schematic Diagram	8-129
8-75.	A20 Power Supply Board Assembly Component Locations	8-131
8-76.	A20 Power Supply Board Assembly Schematic Diagram	8-131

SECTION I GENERAL INFORMATION

1-1. INTRODUCTION

1-2. This operation and service manual contains the information required to install, operate, test, adjust, and service the Hewlett-Packard Model 4193A Vector Impedance Meter. Figure 1-1 shows the instrument and supplied accessories. This section covers specifications, instrument identification, description, options, accessories, and other basic information.

1-3. Listed on the title page of this manual is a microfiche part number that can be used to order 4 x 6 inch microfilm transparencies of the manual. Each microfiche contains up to 60 photo-duplicates of the manual pages. The microfiche package also includes the latest manual changes supplement as well as all pertinent service notes. To order an additional manual, use the part number listed on the title page of this manual.

1-4. DESCRIPTION

1-5. The HP Model 4193A Vector Impedance Meter is a probe-type, fully automatic microprocessor-based test instrument designed for laboratory and production line applications. It measures and digitally displays impedance magnitude, $|Z|$, and phase angle, θ , of active or passive circuits, in-circuit components, discrete components at test frequencies from 400kHz to 110MHz with 10m Ω (impedance) and 0.1 $^\circ$ (phase) resolution. Frequency and measured impedance and phase are displayed on the front-panel with 4-digit and 3 1/2-digit resolution, respectively. Two measurement speeds are provided: NORMAL and HIGH SPEED. In NORMAL mode operation, the 4193A performs one measurement per second; in HIGH SPEED mode operation, it performs approximately seven measurements per second.

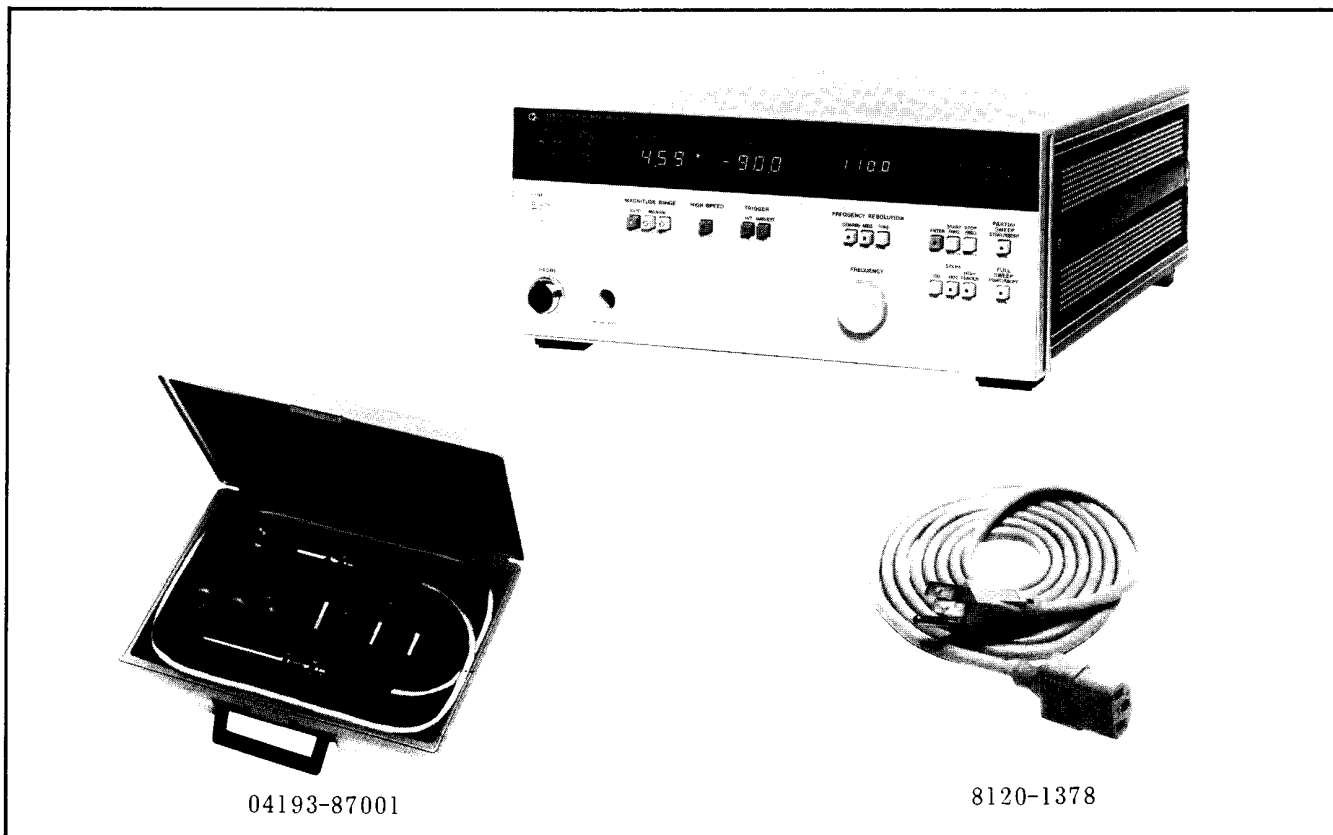

Figure 1-1. Model 4193A and Accessories.

SECTION I

1-6. The 4193A's built-in test signal synthesizer can be set with kHz (maximum) resolution to any frequency within the range of 400kHz to 110MHz for SPOT measurements, or it can be automatically or manually swept in one of two sweep modes: FULL and PARTIAL. In FULL SWEEP mode, frequency is logarithmically swept from 400kHz to 110MHz, and measurement is made at 43 frequency points. In PARTIAL SWEEP mode, frequency is swept from the selected START frequency to the selected STOP frequency. The number of measurement points is selectable at 100, 1000, or HIGH RESOLUTION. Frequency resolution is kHz, 10kHz, or 100kHz, depending on the selected frequency range. For measurements requiring higher frequency resolution, an external frequency synthesizer can be connected. Using this technique, 100Hz frequency resolution can be obtained over the 4193A's full frequency range, 400kHz to 110MHz.

1-7. Test frequency, auto-ranging, frequency sweep, introspective testing (SELF TEST), display, triggering, analog and HP-IB outputs, calculations, and all other instrument functions are microprocessor controlled. This microprocessor-based hardware design makes operation and measurement set-up simple.

1-8. The 4193A is equipped with complete HP-IB capabilities for remote control of all front-panel controls. This feature makes it possible to integrate the 4193A into a cost-efficient measurement system which increases DUT throughput, and improves circuit design efficiency. The 4193A is also equipped with X-Y Recorder outputs and pen lift control. Clear and accurate hard copies of the DUT's impedance-frequency or phase-frequency characteristics can be easily obtained with this capability, without an external controller.

1-9. To maximize the versatility of the 4193A, a wide selection of probe adapters and test fixtures is available. Thus, components of virtually any shape or size can be measured.

1-10. SPECIFICATIONS

1-11. Complete specifications of the Model 4193A Vector Impedance Meter are given in Table 1-1. These specifications are the performance standards or limits against which the instrument is tested. The test procedures for the specifications are covered in Section IV, Performance Tests. Table 1-2 lists supplemental performance characteristics. Supplemental performance characteristics are not specifications but are typical characteristics included as additional information for the

operator. When the 4193A Vector Impedance Meter is shipped from the factory, it meets the specifications listed in Table 1-1.

1-12. SAFETY CONSIDERATIONS

1-13. The Model 4193A Vector Impedance Meter has been designed to conform to the safety requirements of an IEC (International Electromechanical Committee) Safety Class I instrument and is shipped from the factory in a safe condition.

1-14. This operation and service manual contains information, cautions, and warnings which must be followed by the user to ensure safe operation and to maintain the instrument in a safe condition.

1-15. INSTRUMENTS COVERED BY MANUAL

1-16. Hewlett-Packard uses a two-section nine character serial number which is stamped on the serial number plate (Figure 1-2) attached to the instrument's rear-panel. The first four digits and the letter are the serial prefix and the last five digits are the suffix. The letter placed between the two sections identifies the country where the instrument was manufactured. The prefix is the same for all identical instruments; it changes only when a change is made to the instrument. The suffix, however, is assigned sequentially and is different for each instrument. The contents of this manual apply to instruments with the serial number prefix(es) listed under SERIAL NUMBERS on the title page.

1-17. An instrument manufactured after the printing of this manual may have a serial number prefix that is not listed on the title page. This unlisted serial number prefix indicates the instrument is different from those described in this manual. The manual for this new instrument may be accompanied by a yellow Manual Changes supplement or have a different manual part number. This supplement contains "change information" that explains how to adapt the manual to the newer instrument.

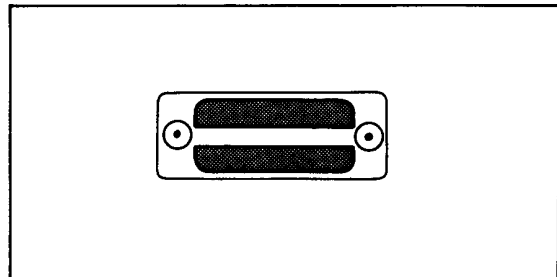

Figure 1-2. Serial Number Plate.

1-18. In addition to change information, the supplement may contain information for correcting errors (called Errata) in the manual. To keep this manual as current and accurate as possible, Hewlett-Packard recommends that you periodically request the latest Manual Changes supplement. The supplement for this manual is identified with this manual's print date and part number, both of which appear on the manual's title page. Complimentary copies of the supplement are available from Hewlett-Packard. If the serial prefix or number of an instrument is lower than that on the title page of this manual, see Section VII, Manual Changes.

1-19. For information concerning a serial number prefix that is not listed on the title page or in the Manual Change supplement, contact the nearest Hewlett-Packard office.

1-20. OPTIONS

1-21. Options are modifications to the standard instrument that implement the user's special requirements for minor functional changes. The 4193A has four options:

- Option 907: Front Handle Kit.
Furnishes Carrying handles for both ends of front-panel.
- Option 908: Rack Frange Kit.
Furnishes flanges for rack mounting for both ends of front-panel.

Option 909: Rack Flange and Front Handle Kit. Furnishes both front handles and rack flanges for instrument.

Option 910: An extra copy of the Operation and Service Manual.

Installation procedures for these options are given in Section II.

1-22. ACCESSORIES SUPPLIED

1-23. The Model 4193A VECTOR IMPEDANCE METER, along with its furnished accessories, is shown in Figure 1-1. The furnished accessories are also listed below:

Probe Kit.....	HP Part No. 04193-87001
Power Cable	HP Part No. 8120-1378
Fuse	HP Part No. 2110-0304

Probe kit contents are listed in Table 1-3.

1-24. ACCESSORIES AVAILABLE

1-25. A test fixture adapter and three test fixtures are available to facilitate measurement on a wide range of discrete components. Also available is a calibration-standard set for calibration of the 4193A or similar probe-type instruments. A brief description of each available accessory is given in Table 1-4.

Table 1-1. Specifications. (Sheet 1 of 5)

SPECIFICATIONS

IMPEDANCE MAGNITUDE MEASUREMENT :

Range, Display, and Resolution :

MAGNITUDE RANGE	DISPLAY RANGE	DISPLAY (digit)	RESOLUTION
10Ω	00.00Ω to 19.99Ω	3 1/2	10mΩ
100Ω	000.0Ω to 199.9Ω	3 1/2	100mΩ
1kΩ	0.000kΩ to 1.999kΩ	3 1/2	1Ω
10kΩ	00.00kΩ to 19.99kΩ	3 1/2	10Ω
100kΩ	000.kΩ to 120.kΩ	2 1/2	1kΩ

Accuracy : See Table A.

Range Mode : Auto and manual (up-down).

IMPEDANCE PHASE MEASUREMENT :

Range and Resolution :

MAGNITUDE RANGE	DISPLAY RANGE	RESOLUTION
10Ω	180.0° to -180.0°	0.1°
100Ω	180.0° to -180.0°	0.1°
1kΩ	180.0° to -180.0°	0.1°
10kΩ	180.0° to -180.0°	0.1°
100kΩ	180.° to -180.°	1°

Accuracy : See Table A.

Table A. Accuracies

MAGNITUDE RANGE	Test Frequency (MHz)			
	0.4 to 1	1 to 10	10 to 40	40 to 110
100.	Z ±[(5.7+ $\frac{0.56}{Z}$); of reading +9 counts]	±[6.3; of reading +6 counts]	±[(4.5+0.18f); of reading +4 counts]	±[(4.5+0.18); of reading +4 counts]
	θ ±(1.7+ $\frac{1.8}{f}+\frac{35}{Z}$) degrees	±(3.3+0.20f+ $\frac{35}{Z}$) degrees	±(3.3+0.20f+ $\frac{35}{Z}$) degrees	±(3.3+0.20f+ $\frac{35}{Z}$) degrees
100.	Z ±[(2.4+ $\frac{0.56}{Z}$) of reading +4 counts]	±[3.0; of reading +4 counts]	±[(2.6+0.037f); of reading +4 counts]	±[(2.6+0.037f); of reading +4 counts]
	θ ±(1.5+ $\frac{1.9}{f}+\frac{35}{Z}$) degrees	±(3.3+0.035f+ $\frac{35}{Z}$) degrees	±(3.3+0.035f+ $\frac{35}{Z}$) degrees	±(3.3+0.035f+ $\frac{35}{Z}$) degrees
1k..	Z ±[(3.2+ $\frac{0.56}{Z}$) of reading +4 counts]	±[3.7; of reading +4 counts]	±[(2.7+0.11f); of reading +4 counts]	±[(2.7+0.11f); of reading +4 counts]
	θ ±(1.6+ $\frac{1.8}{f}+\frac{35}{Z}$) degrees	±(3.3+0.11f+ $\frac{35}{Z}$) degrees	±(3.3+0.11f+ $\frac{35}{Z}$) degrees	±(3.3+0.11f+ $\frac{35}{Z}$) degrees
10k..	Z ±[(2.9+ $\frac{0.56}{Z}$); of reading +4 counts]	±[(3.2+0.29f); of reading +4 counts]	±[(0.74+0.53f); of reading +4 counts]	
	θ ±(1.8+ $\frac{1.9}{f}+\frac{35}{Z}$) degrees	±(3.1+0.53f+ $\frac{35}{Z}$) degrees	±(8.3+0.01f+ $\frac{35}{Z}$) degrees	
100k..*	Z ±[(3.3+ $\frac{0.56}{Z}$) of reading +4 counts]			
	θ ±(3.0 + $\frac{1.9}{f} + \frac{35}{Z}$) degrees			

Where, f is test frequency in MHz, and Z is number of MAGNITUDE display counts. On the 100k.. range, the small zero "0" is not counted in Z.

*: Measurement accuracy is not specified above 100k..

Table 1-1. Specifications (Sheet 2 of 5)

TEST FREQUENCY :

Range and Resolution :

TEST FREQUENCY RANGE	RESOLUTION
0.400 to 9.999MHz	1kHz
10.00 to 99.99MHz	10kHz
100.0 to 110.0MHz	100kHz

Accuracy : $\pm 0.01\%$ of settingStability : ± 100 ppm (at 0 °C to 55 °C)

Full Frequency Sweep :

Test frequency is automatically and logarithmically swept from 400kHz to 110MHz. Measurement is made at the following 43 frequency points.

400kHz, 455kHz, 500kHz, 600kHz, 700kHz, 800kHz, 900kHz, 1MHz, 1.2MHz, 1.4MHz, 1.6MHz, 1.8MHz, 2MHz, 2.333MHz, 2.666MHz, 3MHz, 3.5MHz, 4MHz, 4.5MHz, 5MHz, 6MHz, 7MHz, 8MHz, 9MHz, 10MHz, 12MHz, 14MHz, 16MHz, 18MHz, 20MHz, 23.33MHz, 26.66MHz, 30MHz, 35MHz, 40MHz, 45MHz, 50MHz, 60MHz, 70MHz, 80MHz, 90MHz, 100MHz, 110MHz.

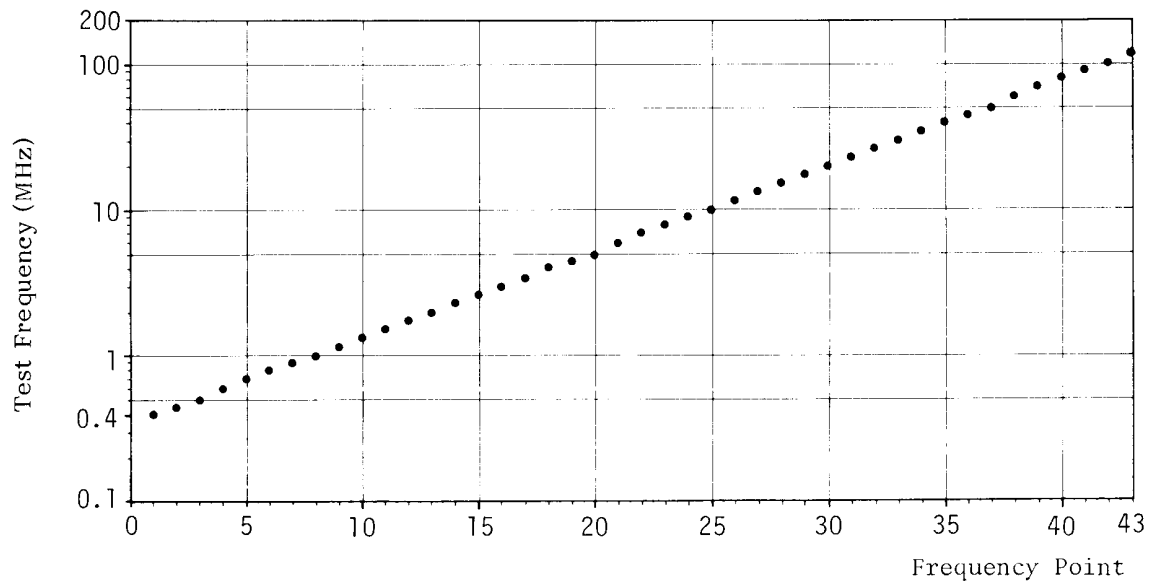

Figure A. Full-Sweep Frequency Points.

Table 1-1. Specifications (Sheet 3 of 5)

Partial Frequency Sweep :

Test frequency is automatically and linearly swept from the selected START FREQ. to the selected STOP FREQ. Number of measurement points is selectable with the STEPS keys--100, 1000, HIGH RESOLN.

100 : One hundred measurement points.

1000: One thousand measurement points.

HIGH RESOLN : Maximum step resolution for the selected sweep frequency range (START to STOP) is automatically selected.

MEASUREMENT TERMINAL : Two-terminal low-grounded probe, connected to instrument with a coaxial cable.

REFERENCE PLANE : Probe tip without probe pin.

RECORDER OUTPUTS : DC voltage outputs proportional to displayed values.

Magnitude Output : 0 to 1 Vdc proportional to displayed MAGNITUDE value
max 1 Vdc (at 2000 counts).

Phase Output : -1 Vdc to +1 Vdc proportional to displayed PHASE value
max ± 1 Vdc (at ± 1800 counts).

Frequency Output : 0 to 1 Vdc proportional to test frequency, as follows:

$$V_F = \frac{F_{STOP} - F_{START}}{F_{STOP} - F_{START}} \quad \text{for manual and Partial Sweep}$$

$$V_F = \frac{\log (F_{STOP} / F_{START})}{\log (F_{STOP} / F_{START})} \quad \text{for Full Sweep}$$

where, V_F is the analog output voltage.

0 Vdc and 1 Vdc for START frequency and STOP frequency, respectively.

PEN LIFT : TTL level signal. Goes LOW (PEN DOWN) at start of frequency sweep; goes HIGH (PEN UP) at completion of frequency sweep.

TRIGGER : Internal, external, or manual.

EXTERNAL TEST SIGNAL : External oscillator can be connected to obtain higher test frequency resolution.

Frequency : 400kHz to 110MHz.

Input Level : 0dBm to +5dBm.

Input Terminal : BNC connector.

Table 1-1. Specifications (Sheet 4 of 5)

SELF TEST: Checks the 4193A's basic operation and displays the test results. Initiated each time the instrument is turned on or when the SELF TEST mode is set by the SELF TEST key or via the HP-IB. Refer to paragraph 3-7.

HP-IB INTERFACE: Remote control and data output via the HP-IB (based on IEEE-Std-488 and ANSI-MCI).

Interface Capability : SHI, AHI, T5, L4, SRI, RLI, DCI, DTI, EI

Remote Control Function : All front-panel functions except LINE ON/OFF switch

Data Output : Measured impedance magnitude and phase values, test frequency value, and measurement setting information.

WARM-UP TIME: ≥ 60 minutes

AMBIENT TEMPERATURE: $23^{\circ}\text{C} \pm 5^{\circ}\text{C}$ (error limits double in magnitude and phase accuracies for 0°C to 55°C temperature range).

GENERAL

Operating Temperature : 0°C to $+55^{\circ}\text{C}$

Storage Temperature : -40°C to $+75^{\circ}\text{C}$

Humidity : $\leq 95\%$ at 40°C

Power Requirements : 100, 120, 220V $\pm 10\%$; 240V $+5\%$ -10% ;
48 to 66Hz; power consumption 150VA, maximum

Probe Cable Length : Approximately 150cm, measured from the front-panel to the probe tip.

Dimensions : 426mm (W) x 177mm (H) x 513mm (D) (16.77" x 7" x 20")

Weight : Approximately 18 kg.

OPTIONS

Option 907 : Front handle kit (P/N 5061-0090)

Option 908 : Rack flange kit (P/N 5061-0078)

Option 909 : Rack flange and handle kit (P/N 5061-0084)

Option 910 : Extra Manual

Table 1-1. Specifications (Sheet 5 of 5)

ACCESSORIES

Accessories Supplied :

Part Number	Accessory Name	Q'ty
04193-61151	Probe	1
04193-61152	Probe Adapter	1
04193-61153	Component Adapter	1
04193-61154	Ground Adapter	1
04193-61629	Ground Lead	1
04193-21008	Probe Socket	1
0360-2065	Spare Clips	3
04193-21023	Spare N-type Pins	5
16095-29005	Spare Pins	10
04193-60152	Probe Kit Case	1
1540-0692	Pin Case	3

Accessories Available :

16099A TEST FIXTURE ADAPTER: Connects Probe to one of three test fixtures, Model 16092A/16093A/16093B, for component measurement.

16345A PROBE TYPE CALIBRATION BOX: Contains 10 standards, SHORT/OPEN/10 Ω /50 Ω /100 Ω /180 Ω /1k Ω /1.8k Ω /10k Ω /5pF, for calibration of probe-type instruments.

16092A SPRING CLIP FIXTURE: Mounts atop the 16099A TEST FIXTURE ADAPTER. Used for discrete component measurements.

16093A BINDING POST FIXTURE: Mounts atop the 16099A TEST FIXTURE ADAPTER. Used for discrete component measurements.

16093B BINDING POST FIXTURE: Mounts atop the 16099A TEST FIXTURE ADAPTER. Used for discrete component measurements.

Table 1-2. General Information

SUPPLEMENTAL PERFORMANCE CHARACTERISTICS

MEASUREMENT TIME

Normal Mode : Approximately 1 sec. (typical)
 High Speed Mode : Approximately 150 msec. (typical)

FREQUENCY SETTling TIME

Approximately 5ms to 400ms

RANGING TIME

Approximately 1.2s

PROBE WITHSTAND VOLTAGE

DC : 50V maximum
 AC : 5Vrms maximum

OUTPUT IMPEDANCE

Approximately 25Ω with 0.2μF series capacitance

RESIDUALS

Resistance in series with DUT (R_s) : $\leq 0.55\Omega$

Inductance in series with DUT (L_s) : $\leq (4.9 + \frac{10}{f})\text{nH}$ *2

Capacitance in parallel with DUT (C_p) : $\leq 0.1\text{pF}$

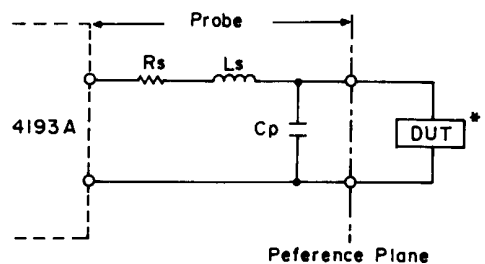

Note

*1 : DUT includes the probe pin.

*2 : f is test frequency in MHz.

TEST SIGNAL LEVEL :

MAGNITUDE RANGE	CURRENT Thru DUT (μArms)
10Ω	100
100Ω	100
1kΩ	100
10kΩ	50
100kΩ	10

Note : Current through the DUT is constant for each magnitude range.

Accuracy : $\pm 20\%$

RESIDUAL FM

100Hz_{F-P} for 1 thru 110MHz at 100Hz BW.

SKIP ERROR

10 counts maximum at 2.5MHz, 5MHz, and 10MHz.

SECTION I

Table I-3. Probe Kit for 4193A

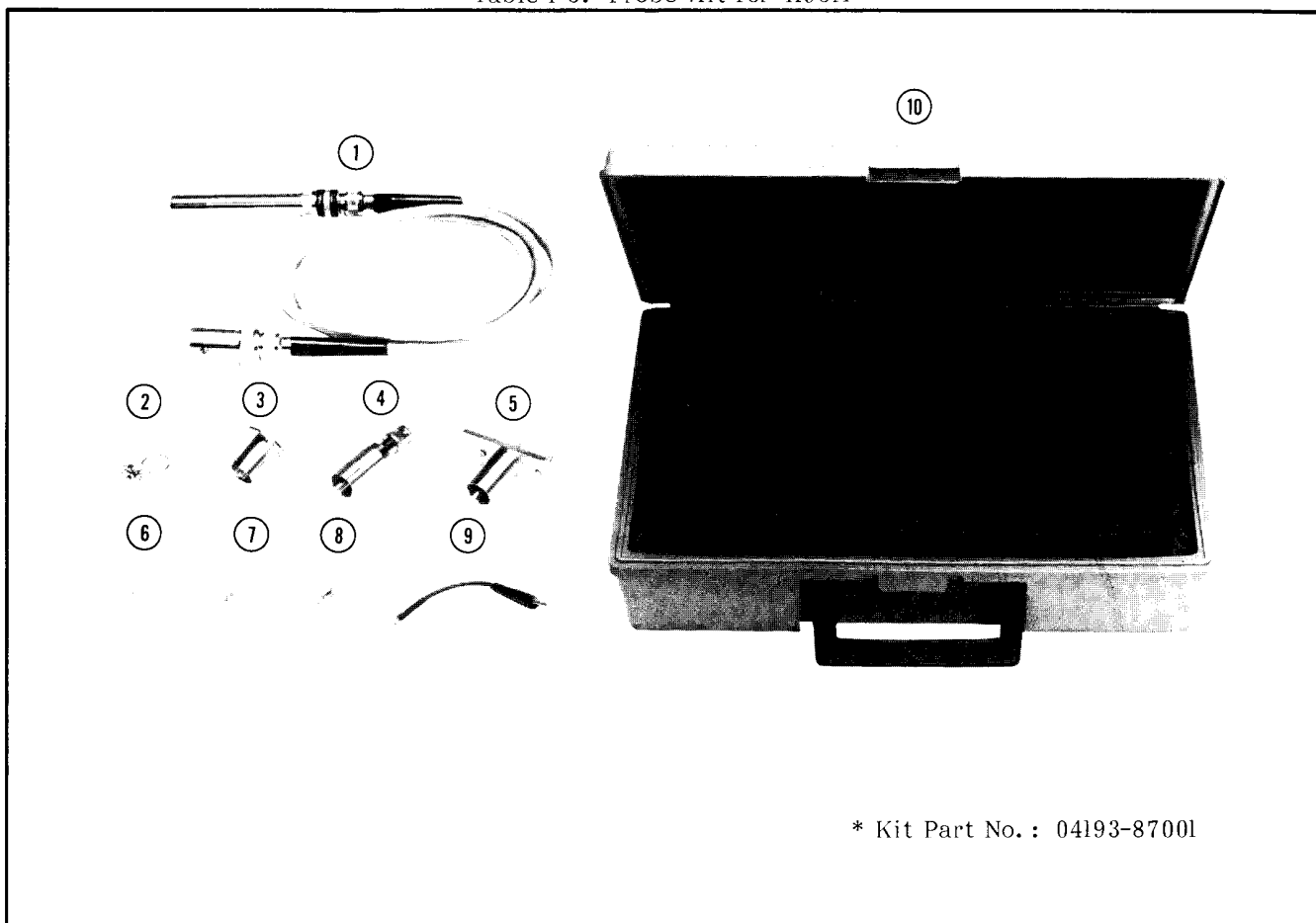

* Kit Part No. : 04193-87001

Reference	HP Part Number	Qty	Description
①	04193-61151	1	PROBE
②	04193-61154	1	GROUND ADAPTER
③	04193-21008	1	PROBE SOCKET
④	04193-61152	1	BNC ADAPTER
⑤	04193-61153	1	COMPONENT ADAPTER
⑥	04193-60153	1	SPARE N-TYPE PIN SET Contains five spare N-type pins (HP Part No.: 04193-21023)
⑦	16095-60012	1	SPARE PIN SET Contains ten spare N-type pins (HP Part No.: 16095-29005)
⑧	04193-60151	1	SPARE CLIP SET Contains three spare clips (HP Part No.: 0360-2065)
⑨	04193-61629	1	GROUND LEAD
⑩	04193-60152	1	PROBE KIT CASE

Table I-4. Accessories Available (Sheet I of 3)

Model	Description
<p data-bbox="224 380 591 407">HP16092A Spring Clip Fixture</p> 	<p data-bbox="865 380 1393 548">Test Fixture (direct attachment type) for measurement of both axial and radial lead components and lead-less chip elements. Spring clip contacts are capable of holding samples of dimensions given below :</p>  <p data-bbox="865 894 1393 1062">A combined slide gauge provides direct readouts of the physical length of the sample tested. Usable frequency range is DC to 500MHz. The 16099A Test Fixture Adapter is necessary to connect the 4193A Probe.</p>
<p data-bbox="224 1213 610 1241">HP16093A Binding Post Fixture</p> 	<p data-bbox="865 1213 1393 1381">Test Fixture (direct attachment type) for measurement of both axial and radial lead miniature components. Two binding post terminals at an interval of 7mm on the terminal deck ensure optimum contact of terminals and sample leads.</p>  <p data-bbox="865 1812 1393 1927">Usable frequency range is DC to 250MHz. The 16099A Test Fixture Adapter is necessary to connect the 4193A Probe.</p>

Table 1-4. Accessories Available (sheet 2 of 3)

Model	Description
<p data-bbox="201 373 586 401">HP16093B Binding Post Fixture</p> 	<p data-bbox="846 369 1370 510">Test Fixture (direct attachment type) for general measurement of both axial and radial lead components. Three binding post terminals are located on the terminal deck as shown below :</p>  <p data-bbox="846 999 1370 1115">Usable frequency range is DC to 125MHz. The 16099A Test Fixture Adapter is necessary to connect the 4193A Probe.</p>
<p data-bbox="201 1178 607 1205">HP 16099A Test Fixture Adapter</p> 	<p data-bbox="846 1173 1370 1289">Test Fixture Adapter for connecting the 4193A probe to one of the three available test fixtures—16092A, 16093A, and 16093B.</p> <p data-bbox="846 1314 1370 1398">Note: The 16099A and each of the available test fixtures must be ordered separately.</p> <ul style="list-style-type: none"> <li data-bbox="899 1556 1370 1583">① :HP16092A SPRING CLIP FIXTURE <li data-bbox="899 1598 1370 1625">② :HP16093A BINDING POST FIXTURE <li data-bbox="899 1640 1370 1667">③ :HP16093B BINDING POST FIXTURE

Table I-4. Accessories Available (sheet 3 of 3)

Model	Description
<p data-bbox="228 373 703 401">HP16345A Probe Type Calibration Box</p> 	<p data-bbox="870 373 1398 596">Calibration standard for performance testing and adjustment of the 4193A. Includes ten probe-insertable standards : OPEN, SHORT, 10Ω, 50Ω, 100Ω, 180Ω, 1kΩ, 1.8kΩ, 10kΩ, and 5pF. If a standard is damaged or fails to perform properly, contact your nearest Hewlett-Packard Sales and Service Office.</p> <p data-bbox="870 630 1398 657">Dimensions : 310(W)x80(H)x205(D) [mm]</p> <p data-bbox="870 716 1292 743">Weight : Approximately 2.1kg</p>

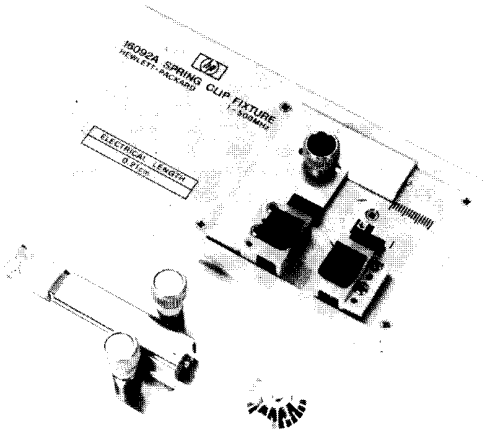
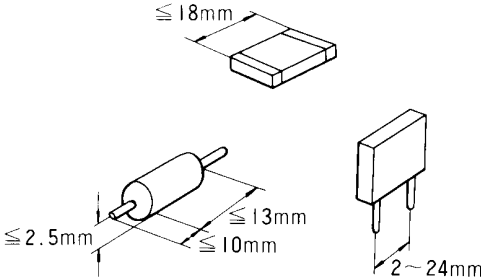
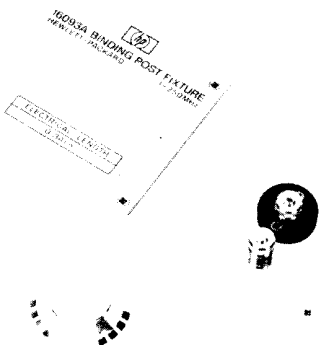
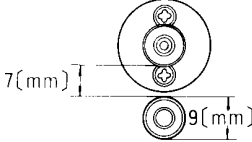
SECTION II INSTALLATION

2-1. INTRODUCTION

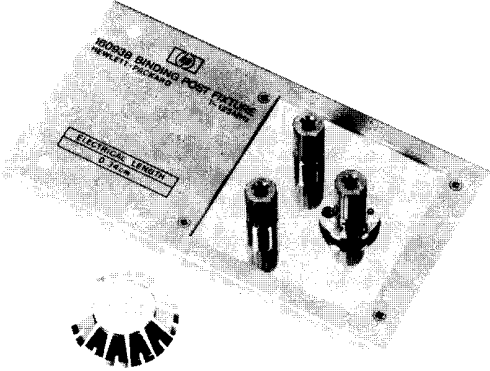
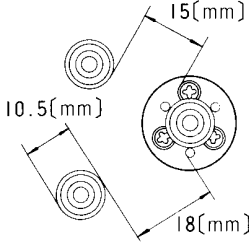
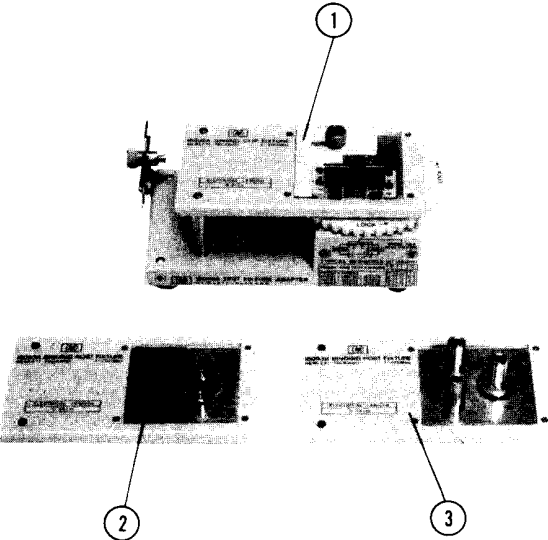
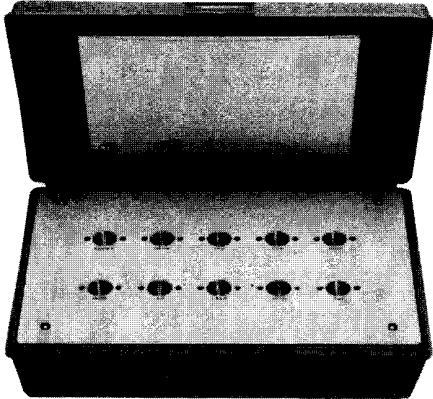
2-2. This section provides installation instructions for the Model 4193A Vector Impedance Meter. This section also includes information on initial inspection and damage claims, preparation for using the 4193A, packaging, storage, and shipment.

2-3. INITIAL INSPECTION

2-4. The 4193A Vector Impedance Meter, as shipped from the factory, meets all the specifications listed in Table 1-1. On receipt, inspect the shipping container for damage. If the shipping container or cushioning material is damaged, notify the carrier as well as the nearest Hewlett-Packard office and be sure to keep the shipping materials for carrier's inspection until the contents of the shipment have been checked for completeness and the instrument has been checked mechanically and electrically. The contents of the shipment should be as shown in Figure 1-1. The procedures for checking the general electrical operation are given in Section III (Paragraph 3-7 SELF TEST) and the procedures for checking the 4193A Vector Impedance Meter against its specifications are given in Section IV. First, do the self test. If the 4193A Vector Impedance Meter is electrically questionable, then do the Performance Tests to determine whether the 4193A has failed or not.

If the contents are incomplete, if there is mechanical damage or defects (scratches, dents, broken switches, etc.), or if the performance does not meet the self test or performance tests, notify the nearest Hewlett-Packard office (see list at back of this manual). The HP office will arrange for repair or replacement without waiting for claim settlement.

2-5. PREPARATION FOR USE

2-6. POWER REQUIREMENTS

2-7. The 4193A requires a power source of 100, 120, 220Volts ac +10%, or 240Volts ac +5%-10%, 48 to 66Hz single phase; power consumption is 150VA maximum.

WARNING

IF THE INSTRUMENT IS TO BE ENERGIZED VIA AN EXTERNAL AUTOTRANSFORMER FOR VOLTAGE REDUCTION, BE SURE THAT THE COMMON TERMINAL IS CONNECTED TO THE NEUTRAL POLE OF THE POWER SUPPLY.

2-8. Line Voltage and Fuse Selection

CAUTION

BEFORE TURNING THE 4193A LINE SWITCH TO ON, VERIFY THAT THE INSTRUMENT IS SET TO THE VOLTAGE OF THE POWER TO BE SUPPLIED.

2-9. Figure 2-1 provides instructions for line voltage and fuse selection. The line voltage selection switch and the proper fuse are factory installed for 100 or 120 volts ac operation.

CAUTION

USE PROPER FUSE FOR LINE VOLTAGE SELECTED.

CAUTION

MAKE SURE THAT ONLY FUSES FOR THE REQUIRED RATED CURRENT AND OF THE SPECIFIED TYPE ARE USED FOR REPLACEMENT. THE USE OF MENDED FUSES AND THE SHORT-CIRCUITING OF FUSE-HOLDERS MUST BE AVOIDED.

2-10. POWER CABLE

2-11. To protect operating personnel, the National Electrical Manufacturer's Association (NEMA) recommends that the instrument panel and cabinet be grounded. The Model 4193A is equipped with a three-conductor power cable which, when plugged into an appropriate receptacle, grounds the instrument. The offset pin on the power cable is the ground wire.

SECTION II

2-12. To preserve the protection feature when operating the instrument from a two contact outlet, use a three prong to two prong adapter (HP Part No. 1251-0048) and connect the green pigtail on the adapter to power line ground.

CAUTION

THE MAINS PLUG MUST ONLY BE INSERTED IN A SOCKET OUTLET PROVIDED WITH A PROTECTIVE EARTH CONTACT. THE PROTECTIVE ACTION MUST NOT BE NEGATED BY THE USE OF AN EXTENSION CORD (POWER CABLE) WITHOUT PROTECTIVE CONDUCTOR (GROUNDING).

2-13. Figure 2-2 shows the available power cords, which may be used in various countries including the standard power cord furnished with the instrument. HP Part number, applicable standards for power plug, power cord color, electrical characteristics and countries using each power cord are listed in the figure. If assistance is needed for selecting the correct power cable, contact the nearest Hewlett-Packard office.

2-14. OPERATING ENVIRONMENT

2-15. Temperature. The instrument may be operated in temperatures from 0°C to +55°C.

2-16. Humidity. The instrument may be operated in environments with relative

humidities to 90% at 40°C. However, the instrument should be protected from temperature extremes which cause condensation within the instrument.

2-17. INSTALLATION INSTRUCTIONS

2-18. The HP Model 4193A can be operated on the bench or in a rack mount. The 4193A is ready for bench operation as shipped from the factory. For bench operation a two-leg instrument stand is used. For use, the instrument stands are designed to be pulled towards the front of instrument.

2-19. Installation of Options 907, 908 and 909

2-20. The 4193A can be installed in a rack and be operated as a component of a measurement system. Rack mounting information for the 4193A is presented in Figure 2-3.

2-21. STORAGE AND SHIPMENT

2-22. ENVIRONMENT

2-23. The instrument may be stored or shipped in environments within the following limits:

Temperature -40 °C to +75 °C
 Humidity to 95% at 40 °C

The instrument should be protected from temperature extremes which cause condensation inside the instrument.

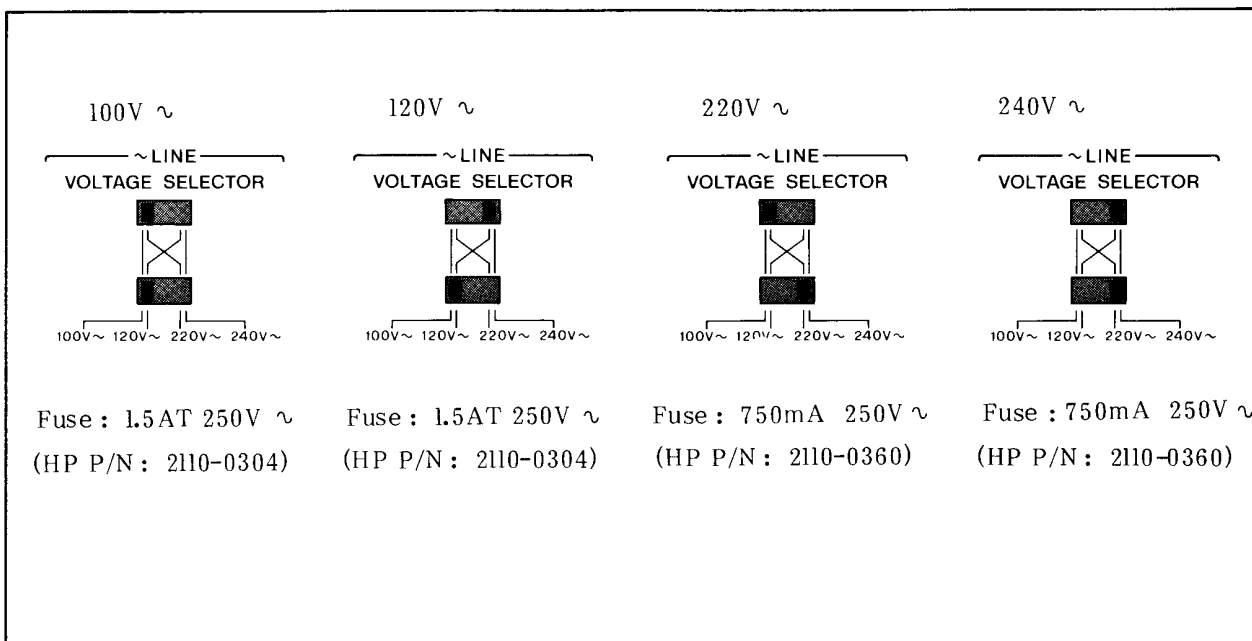

Figure 2-1. Voltage and Fuse Selection.

<p>OPTION 900</p> <p>United Kingdom</p>  <p>Earth Neutral Line</p> <p>Plug : BS 1363A, 250V Cable : HP 8120-1351</p>	<p>OPTION 901</p> <p>Australia/New Zealand</p>  <p>Earth Neutral Line</p> <p>Plug : NZSS 198/AS C112, 250V Cable : HP 8120-1369</p>
<p>OPTION 902</p> <p>European Continent</p>  <p>Earth Line Neutral Earth</p> <p>Plug : CEE-VII, 250V Cable : HP 8120-1689</p>	<p>OPTION 903</p> <p>U.S./Canada</p>  <p>Earth Neutral Line</p> <p>Plug : NEMA 5-15P, 125V, 15A Cable : HP 8120-1378</p>
<p>OPTION 905*</p> <p>Any country</p>  <p>Line Neutral Earth</p> <p>Plug : CEE 22-VI, 250V Cable : HP 8120-1396</p>	<p>OPTION 906</p> <p>Switzerland</p>  <p>Neutral Line Earth</p> <p>Plug : SEV 1011.1959-24507 Type 12, 250V Cable : HP 8120-2104</p>
<p>OPTION 912</p> <p>Denmark</p>  <p>Line Neutral Earth</p> <p>Plug : DHCR 107, 220V Cable : HP 8120-2956</p>	<p>* Plug option 905 is frequently used for interconnecting system components and peripherals.</p> <p>NOTE: Each option number includes a 'family' of cords and connectors of various materials and plug body configurations (straight, 90° etc.)</p>

Figure 2-2. Power Cables Supplied.

SECTION II

2-24. PACKAGING

2-25. Original Packaging. Containers and materials identical to those used in factory packaging are available from Hewlett-Packard. If the instrument is being returned to Hewlett-Packard for servicing, attach a tag indicating the type of service required, return address, model number, and full serial number. Also mark the container FRAGILE to assure careful handling. In any correspondence, refer to the instrument by model number and full serial number.

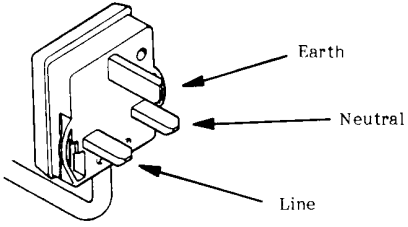
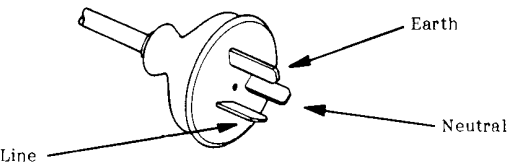
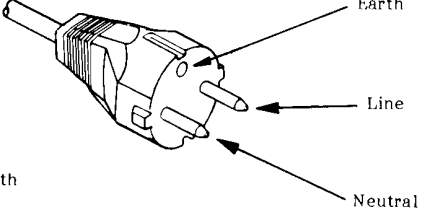
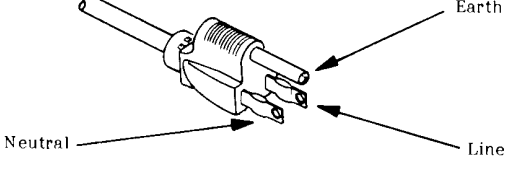
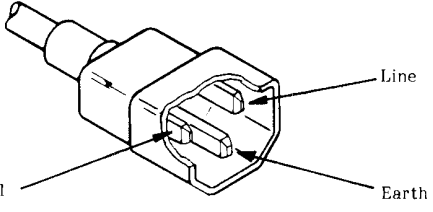
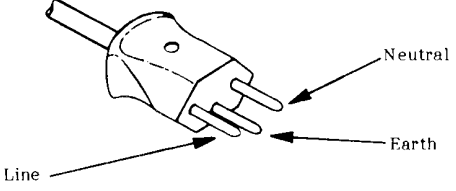
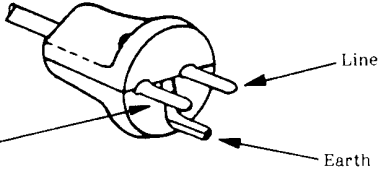
2-26. Other Packaging. The following general instructions should be used for re-packing with commercially available materials:

- a. Wrap instrument in heavy paper or plastic. If shipping to Hewlett-Packard office or service center, attach tag indicating type of service required, return address, model number, and full serial number.

- b. Use strong shipping container. A double-wall carton made of 350 pound test material is adequate.
- c. Use enough shock absorbing material (3 to 4 inch layer) around all sides of instrument to provide firm cushion and prevent movement inside container. Protect control panel with cardboard.
- d. Seal shipping container securely.
- e. Mark shipping container FRAGILE to ensure careful handling.
- f. In any correspondence, refer to instrument by model number and full serial number.

Option	Kit Part Number	Parts Included	Part Number	Q'ty	Remarks
907	Handle Kit 5061-0090	Front Handle Trim Strip X8-32 x 3/8 Screw	③ 5060-9900 ④ 5020-8897 2510-0195	2 2 6	9.525mm
908	Rack Flange Kit 5061-0078	Rack Mount Flange X8-32 x 3/8 Screw	② 5020-8863 2510-0193	2 6	9.525mm
909	Rack Flange & Handle Kit 5061-0084	Front handle Rack Mount Flange X8-32 x 3/8 Screw	③ 5060-9900 ⑤ 5020-8875 2510-0194	2 2 6	15.875mm

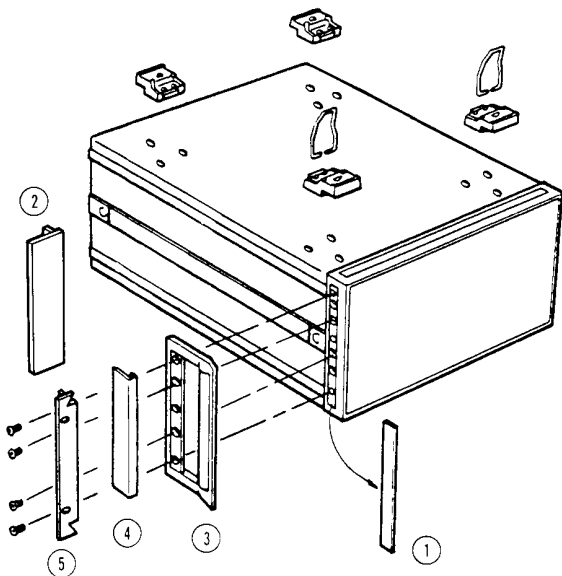

1. Remove adhesive-backed trim strips ① from side at right and left front of instrument.
2. HANDLE INSTALLATION : Attach front handle ③ to sides at right and left front of instrument with screws provided and attach trim ④ to handle.
3. RACK MOUNTING : Attach rack mount flange ② to sides at right and left front of instrument with screws provided.
4. HANDLE AND RACK MOUNTING : Attach front handle ③ and rack mount flange ⑤ together to sides at right and left front of instrument with screws provided.
5. When rack mounting (3 and 4 above), remove all four feet (lift bar at inner side of foot, and slide foot toward the bar).

Figure 2-3. Rack Mount Kit.

SECTION III OPERATION

3-1. INTRODUCTION

3-2. This section provides all the information necessary to operate the Model 4193A Vector Impedance Meter. Included are descriptions of the front- and rear-panels, displays, lamps and connectors; discussions on operating procedures and measuring techniques for various applications; and instructions on the instrument's SELF TEST function. Warnings, Cautions, and Notes are given throughout; they should be observed to insure the safety of the operator and the serviceability of the instrument.

WARNING

BEFORE THE INSTRUMENT IS SWITCHED ON, ALL PROTECTIVE EARTH TERMINALS, EXTENSION CORDS, AUTO-TRANSFORMERS AND DEVICES CONNECTED TO IT SHOULD BE CONNECTED TO A PROTECTIVE EARTH GROUNDED SOCKET. ANY INTERRUPTION OF THE PROTECTIVE EARTH GROUNDING WILL CAUSE A POTENTIAL SHOCK HAZARD THAT COULD RESULT IN SERIOUS PERSONAL INJURY.

ONLY FUSES WITH THE REQUIRED RATED CURRENT AND OF THE SPECIFIED TYPE SHOULD BE USED. DO NOT USE REPAIRED FUSES OR SHORTED FUSEHOLDERS. TO DO SO COULD CAUSE A SHOCK OR FIRE HAZARD.

CAUTION

BEFORE THE INSTRUMENT IS SWITCHED ON, IT MUST BE SET TO THE VOLTAGE OF THE POWER SOURCE (MAINS), OR DAMAGE TO THE INSTRUMENT MAY RESULT.

3-3. OPERATING INSTRUCTIONS

3-4. Operating instructions for the instrument's basic capabilities are given in paragraphs 3-5 through 3-44. Operating instructions for the instrument's extended capabilities (remote operation via the HP-IB, X-Y Recorder Outputs, and External Oscillator) are covered in paragraphs 3-45 through 3-80.

3-5. PANEL FEATURES

3-6. Front- and rear-panel features for the 4193A are described in Figure 3-1 and Figure 3-2, respectively. More detailed information on the panel displays and controls is given in paragraph 3-7 and below.

3-7. SELF TEST

3-8. The 4193A is equipped with an automatic self-diagnostic function that can be initiated at any time to confirm normal operation of the instrument's basic functions. SELF TEST can be initiated from the front-panel by pressing the SELF TEST key or via HP-IB remote control (program code S1). When SELF TEST is initiated (key indicator lamp is on), eight tests of the instrument's digital section are performed and the results (pass code or one of the error codes listed in Table 3-5) are displayed on the FREQUENCY display. If no errors are detected, pass codes P1 through P7, P40, and PASS will be sequentially displayed on the FREQUENCY display and the instrument will then return to normal measurement mode (SELF TEST key indicator lamp off). If an error is detected, the corresponding error code--listed in Table 3-5--will be displayed on the FREQUENCY display and SELF TEST will stop. Error code E-61 is not an instrument failure. Refer to Table 3-3 for the cause and remedy. If the instrument fails SELF TEST (an error code other than E-61 is displayed), contact the nearest Hewlett-Packard Service Office. A list of addresses is provided at the back of this manual.

Note

An abbreviated SELF TEST is automatically performed each time the instrument is turned on. Only error codes--if an error is detected--PASS or FAIL, and the instrument's HP-IB address are displayed at the end of this SELF TEST.

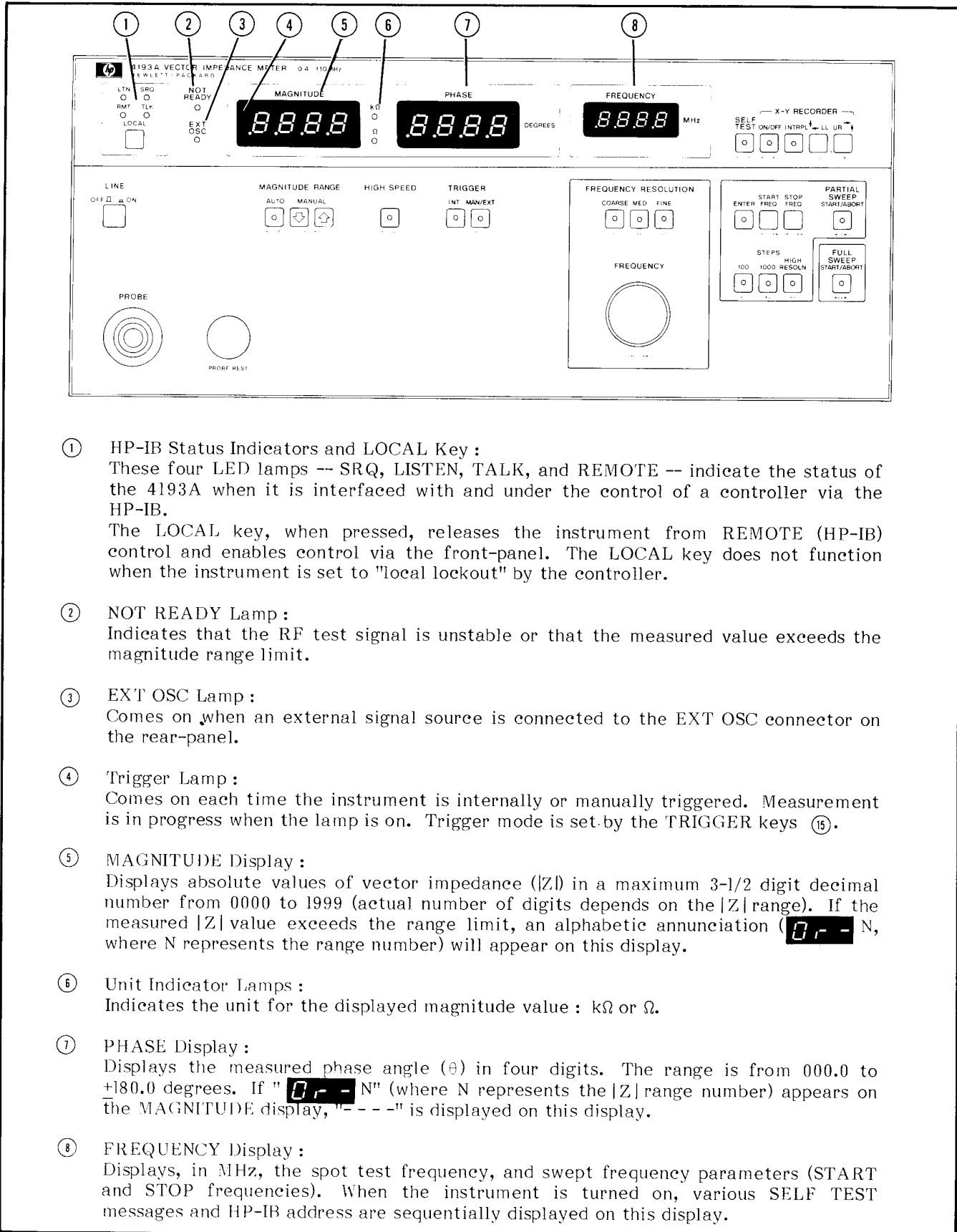

- ① **HP-IB Status Indicators and LOCAL Key :**
These four LED lamps -- SRQ, LISTEN, TALK, and REMOTE -- indicate the status of the 4193A when it is interfaced with and under the control of a controller via the HP-IB.
The LOCAL key, when pressed, releases the instrument from REMOTE (HP-IB) control and enables control via the front-panel. The LOCAL key does not function when the instrument is set to "local lockout" by the controller.
- ② **NOT READY Lamp :**
Indicates that the RF test signal is unstable or that the measured value exceeds the magnitude range limit.
- ③ **EXT OSC Lamp :**
Comes on when an external signal source is connected to the EXT OSC connector on the rear-panel.
- ④ **Trigger Lamp :**
Comes on each time the instrument is internally or manually triggered. Measurement is in progress when the lamp is on. Trigger mode is set by the TRIGGER keys ⑤.
- ⑤ **MAGNITUDE Display :**
Displays absolute values of vector impedance ($|Z|$) in a maximum 3-1/2 digit decimal number from 0000 to 1999 (actual number of digits depends on the $|Z|$ range). If the measured $|Z|$ value exceeds the range limit, an alphabetic annunciation (**0r-N**, where N represents the range number) will appear on this display.
- ⑥ **Unit Indicator Lamps :**
Indicates the unit for the displayed magnitude value : k Ω or Ω .
- ⑦ **PHASE Display :**
Displays the measured phase angle (θ) in four digits. The range is from 000.0 to +180.0 degrees. If **0r-N** (where N represents the $|Z|$ range number) appears on the MAGNITUDE display, "r-N" is displayed on this display.
- ⑧ **FREQUENCY Display :**
Displays, in MHz, the spot test frequency, and swept frequency parameters (START and STOP frequencies). When the instrument is turned on, various SELF TEST messages and HP-IB address are sequentially displayed on this display.

Figure 3-1. Front Panel Features (Sheet 1 of 4).

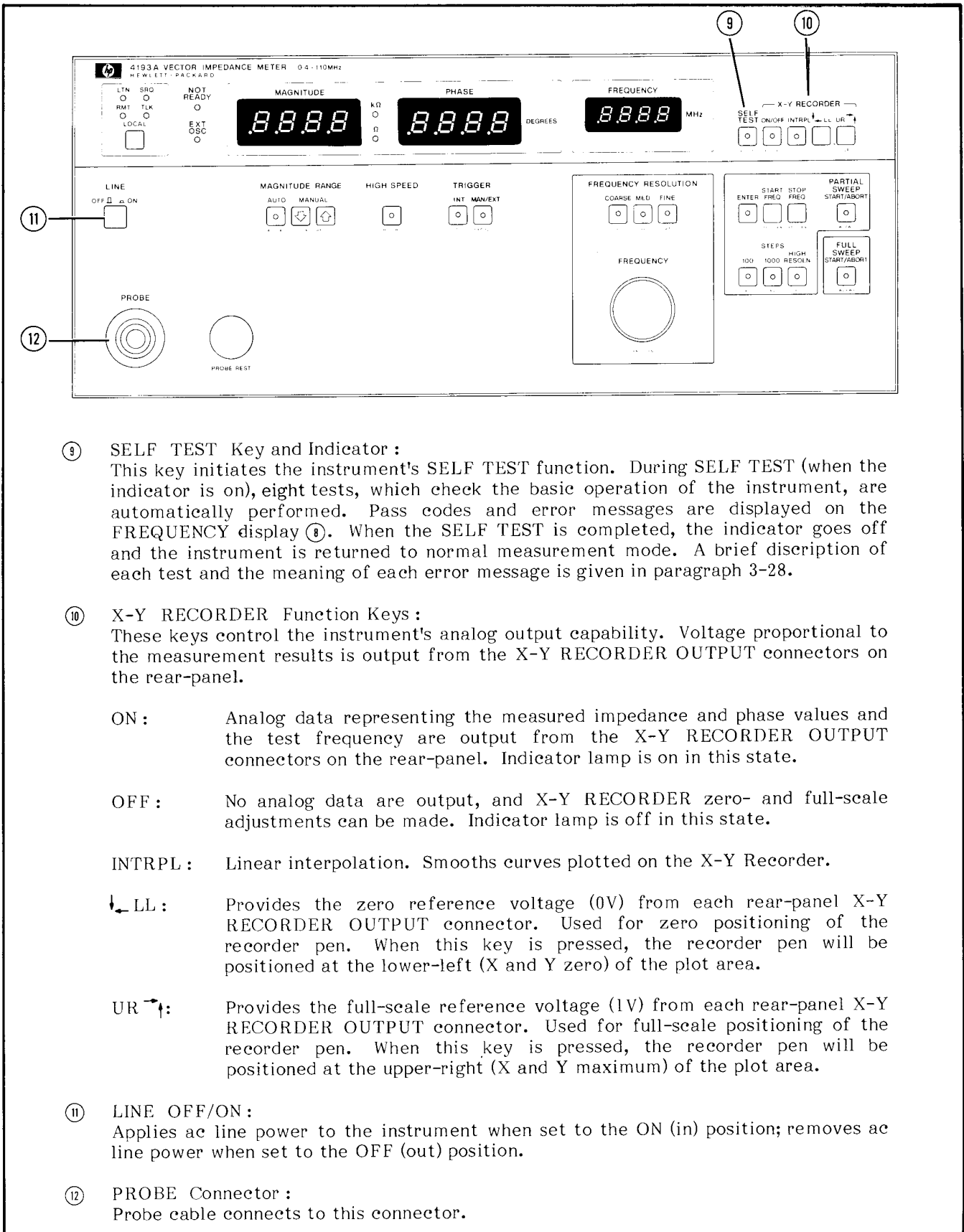

⑨ SELF TEST Key and Indicator :

This key initiates the instrument's SELF TEST function. During SELF TEST (when the indicator is on), eight tests, which check the basic operation of the instrument, are automatically performed. Pass codes and error messages are displayed on the FREQUENCY display ⑧. When the SELF TEST is completed, the indicator goes off and the instrument is returned to normal measurement mode. A brief description of each test and the meaning of each error message is given in paragraph 3-28.

⑩ X-Y RECORDER Function Keys :

These keys control the instrument's analog output capability. Voltage proportional to the measurement results is output from the X-Y RECORDER OUTPUT connectors on the rear-panel.

ON: Analog data representing the measured impedance and phase values and the test frequency are output from the X-Y RECORDER OUTPUT connectors on the rear-panel. Indicator lamp is on in this state.

OFF: No analog data are output, and X-Y RECORDER zero- and full-scale adjustments can be made. Indicator lamp is off in this state.

INTRPL: Linear interpolation. Smooths curves plotted on the X-Y Recorder.

LL: Provides the zero reference voltage (0V) from each rear-panel X-Y RECORDER OUTPUT connector. Used for zero positioning of the recorder pen. When this key is pressed, the recorder pen will be positioned at the lower-left (X and Y zero) of the plot area.

UR: Provides the full-scale reference voltage (1V) from each rear-panel X-Y RECORDER OUTPUT connector. Used for full-scale positioning of the recorder pen. When this key is pressed, the recorder pen will be positioned at the upper-right (X and Y maximum) of the plot area.

⑪ LINE OFF/ON :

Applies ac line power to the instrument when set to the ON (in) position; removes ac line power when set to the OFF (out) position.

⑫ PROBE Connector :

Probe cable connects to this connector.

Figure 3-1. Front Panel Features (Sheet 2 of 4).

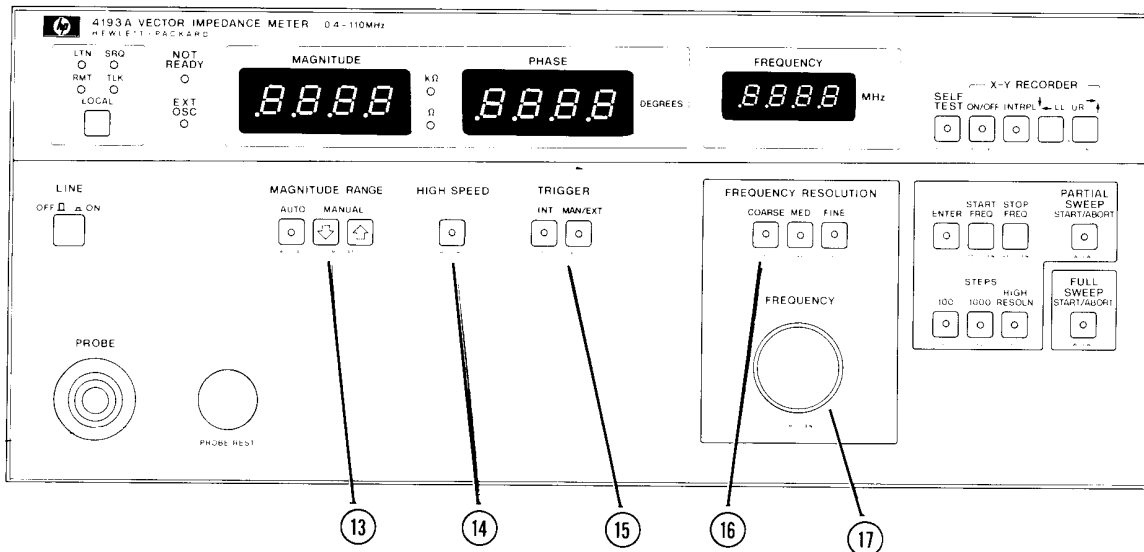

⑬ **MAGNITUDE RANGE Keys :**

These keys are used to select the measurement range.

AUTO: When indicator lamp is on, optimum range for the DUT's impedance is automatically selected.

MANUAL: When the AUTO indicator lamp is off, these keys are used to select the measurement range. Once selected, the range will not change even if the sample is changed. Manual ranging is done by pressing the DOWN (⏴) key or the UP (⏵) key.

⑭ **HIGH SPEED MODE Key:**

Shortens the measurement time and increases the measurement cycle speed.

⑮ **TRIGGER Keys :**

These keys select the trigger mode.

INT: Measurement is triggered by the instrument's internal trigger signal.

MAN/EXT: Measurement is triggered each time this key is pressed, and measurement data are held until the next time the key is pressed. Or the 4193A is triggered by an external trigger.

Note

An external trigger signal can be applied from the rear panel connector. External triggering is performed at the trailing edge of the applied TTL pulse. See paragraph 3-32.

⑯ **FREQ. RESOLUTION Keys :**

Sets the incremental/decremental value for frequency changes made with the Test Frequency Control Dial ⑰. Incremental/decremental value for COARSE, MED, and FINE is 100 counts, 10 counts, and 1 count, respectively.

⑰ **Test Frequency Control Dial :**

Changes the test frequency. Rotating the dial clockwise increases the frequency; rotating it counterclockwise decreases the frequency.

Figure 3-1. Front Panel Features (Sheet 3 of 4).

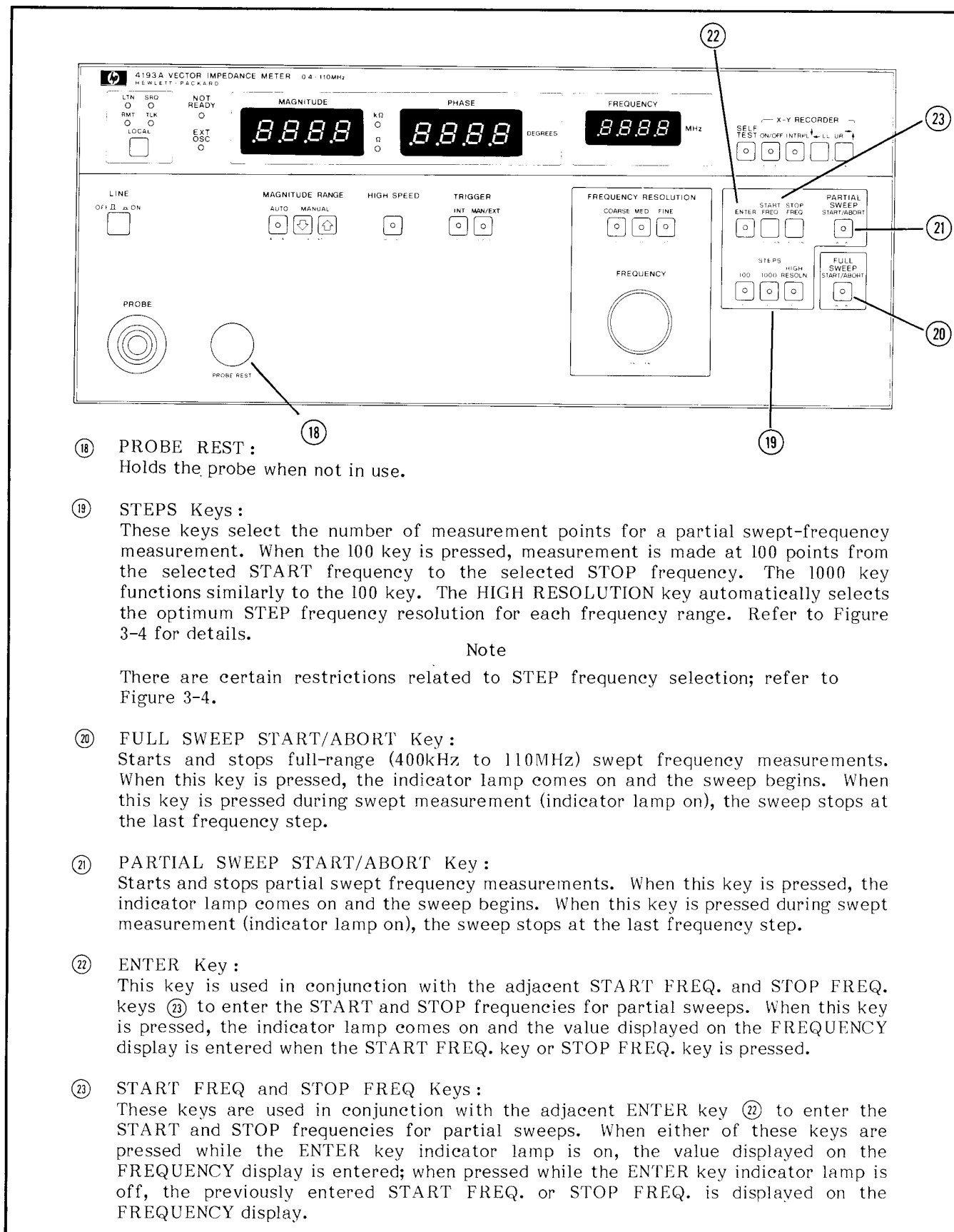

⑱ PROBE REST :
Holds the probe when not in use.

⑲ STEPS Keys :
These keys select the number of measurement points for a partial swept-frequency measurement. When the 100 key is pressed, measurement is made at 100 points from the selected START frequency to the selected STOP frequency. The 1000 key functions similarly to the 100 key. The HIGH RESOLUTION key automatically selects the optimum STEP frequency resolution for each frequency range. Refer to Figure 3-4 for details.

Note

There are certain restrictions related to STEP frequency selection; refer to Figure 3-4.

⑳ FULL SWEEP START/ABORT Key :
Starts and stops full-range (400kHz to 110MHz) swept frequency measurements. When this key is pressed, the indicator lamp comes on and the sweep begins. When this key is pressed during swept measurement (indicator lamp on), the sweep stops at the last frequency step.

㉑ PARTIAL SWEEP START/ABORT Key :
Starts and stops partial swept frequency measurements. When this key is pressed, the indicator lamp comes on and the sweep begins. When this key is pressed during swept measurement (indicator lamp on), the sweep stops at the last frequency step.

㉒ ENTER Key :
This key is used in conjunction with the adjacent START FREQ. and STOP FREQ. keys ㉓ to enter the START and STOP frequencies for partial sweeps. When this key is pressed, the indicator lamp comes on and the value displayed on the FREQUENCY display is entered when the START FREQ. key or STOP FREQ. key is pressed.

㉓ START FREQ and STOP FREQ Keys :
These keys are used in conjunction with the adjacent ENTER key ㉒ to enter the START and STOP frequencies for partial sweeps. When either of these keys are pressed while the ENTER key indicator lamp is on, the value displayed on the FREQUENCY display is entered; when pressed while the ENTER key indicator lamp is off, the previously entered START FREQ. or STOP FREQ. is displayed on the FREQUENCY display.

Figure 3-1. Front Panel Features (Sheet 4 of 4).

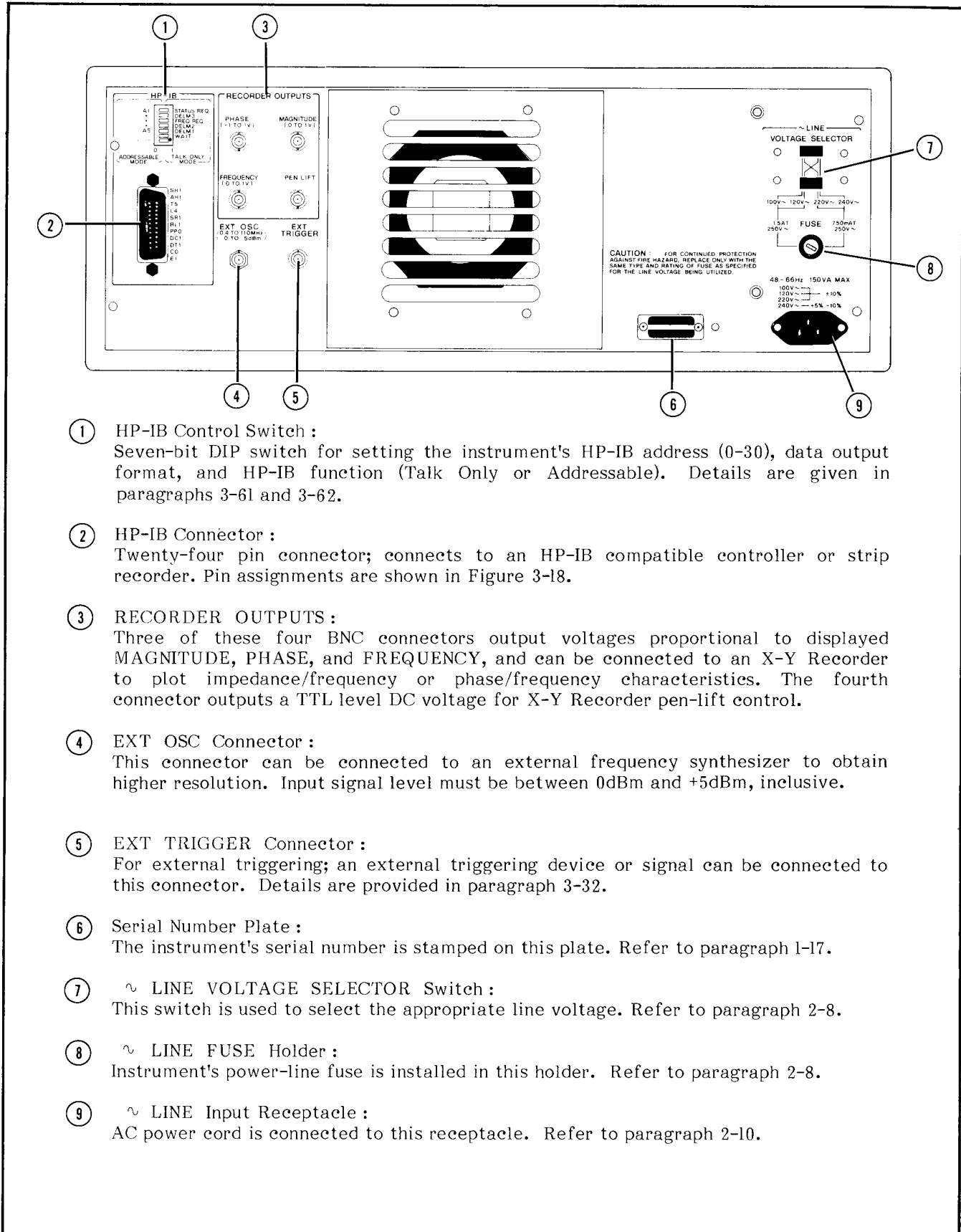

Figure 3-2. Rear Panel Features.

3-9. INITIAL CONTROL SETTINGS

3-10. To facilitate operation, the instrument is automatically set to the following initial control settings each time it is turned on :

Panel Controls :

MAGNITUDE RANGE AUTO
 HIGH SPEED OFF
 TRIGGER INT
 FREQUENCY RESOLUTION .. FINE
 ENTER OFF
 STEPS 100
 PARTIAL SWEEP OFF
 FULL SWEEP OFF
 SELF TEST OFF
 X-Y RECORDER ON/OFF ... OFF
 INTERPOLATION OFF

Test Parameters :

SPOT FREQ. 10MHz
 START FREQ4MHz
 STOP FREQ 110MHz
 RECORDER OUTPUTS0V

3-11. MEASUREMENT RANGE

3-12. As given in Table 3-1, the 4193A has five impedance magnitude ranges. When the MAGNITUDE RANGE is set to AUTO, the 4193A will automatically select the appropriate range. On the other hand, when the MAGNITUDE RANGE is set to MANUAL, the range will be fixed. If the magnitude value for the DUT exceeds the range limit, " **Or** - N" (N is 1, 2, 3, 4, or 5 corresponding to the range number) will be displayed on the MAGNITUDE display.

3-13. TEST SIGNAL LEVEL

3-14. The test signal current through the DUT is constant for the selected measurement range. Refer to Table 3-1. Accordingly, the voltage across the DUT depends on the DUT impedance.

3-15. TEST FREQUENCY

3-16. There are three test frequency ranges, as listed in Table 3-2. Frequency accuracy is 0.01% of the value displayed on the FREQUENCY display. Refer to Figure 3-3 for the frequency setting procedure.

Table 3-1. Measurement Range and Test Signal Level

Magnitude Range	Full-scale Counts	Resolution	Test Signal Level
(1) 10 Ω	19.99 Ω	10m Ω	100 μ Arms
(2) 100 Ω	199.9 Ω	100m Ω	100 μ Arms
(3) 1k Ω	1.999k Ω	1 Ω	100 μ Arms
(4) 10k Ω	19.99k Ω	10 Ω	50 μ Arms
(5) 100k Ω	119. k Ω	1k Ω	10 μ Arms

3-17. SWEPT FREQUENCY MEASUREMENTS

3-18. The 4193A is capable of two types of frequency sweeps : PARTIAL, from the selected START frequency to the selected STOP frequency; and FULL, from 400kHz to 110MHz.

3-19. PARTIAL SWEEP MEASUREMENT

3-20. PARTIAL sweep measurements are used to determine the impedance/phase versus frequency characteristics of a sample over a preselected frequency range. For example, the pass band of a band-pass filter. The test frequency is linearly swept from the selected START frequency to the selected STOP frequency and measurement is made at the number of steps selected by the STEPS keys--100, 1000, or HIGH RES. When HIGH RES is selected, the test frequency is swept (incremented) in accordance with the selected FREQUENCY RESOLUTION key--COARSE, MED, or FINE. The HIGH RES key provides higher step frequency resolution than is possible with the 100 or 1000 STEPS key. For example, if the START frequency is 5MHz, the STOP frequency is 10MHz, and the 1000 STEPS key is selected, measurement is made at 1000 frequency points, which corresponds to a step frequency of 5kHz. But if HIGH RES is used and the FINE key is selected, measurement is made at 5000 frequency points, corresponding to a step frequency of 1kHz. With HIGH RES on, FINE is automatically selected when the PARTIAL SWEEP START/ABORT key is pressed. COARSE or MED can be selected during the sweep. When 100 or 1000 STEPS is selected, the FREQUENCY RESOLUTION keys do not function. The procedure for making a PARTIAL sweep measurement is given in Figure 3-4.

3-21. FULL SWEEP MEASUREMENT

3-22. In FULL sweep measurements the test frequency is logarithmically swept over the 4193A's full frequency range and measurement is made at 43 frequency points. Refer to Figure 3-5 for the frequency of each measurement point. A FULL sweep takes approximately 50 seconds in NORMAL speed mode and 15 seconds in HIGH SPEED mode. The procedure for making a FULL sweep measurement is given in Figure 3-5.

Table 3-2. Test Frequency Range

Test Frequency Range	Resolution
.400 to 9.999MHz	1kHz
10.00 to 99.99MHz	10kHz
100.0 to 110.0MHz	100kHz

SPOT FREQUENCY SETTING PROCEDURE

To manually change the spot frequency, use the procedure given below :

PROCEDURE :

1. Press the FREQUENCY RESOLUTION key labelled COARSE. The indicator lamp in the center of the key will come on.
2. Rotate the FREQUENCY dial (clockwise to increase the frequency, counterclockwise to decrease the frequency) until the two left-most digits of the displayed frequency are at the desired setting.
3. Press the MED key. The indicator lamp in the center of the key will come on.
4. Rotate the FREQUENCY dial until the second digit from the right is at the desired setting.
5. Press the FINE key. The indicator lamp in the center of the key will come on.
6. Rotate the FREQUENCY dial until the right-most digit is at the desired setting.

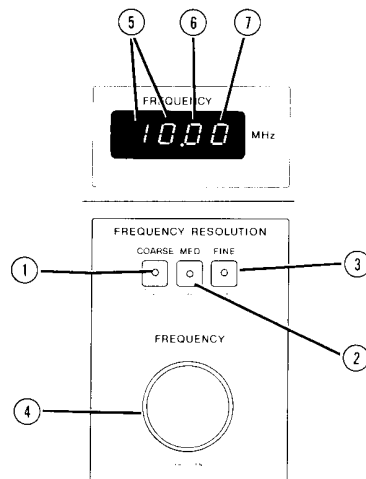

EXAMPLE

Refer to the figure. The desired spot frequency is 55.55MHz.

1. Press the COARSE key ①.
2. Rotate the FREQUENCY dial ④ clockwise until the two left-most digits ⑤ of the displayed frequency are 55.
3. Press the MED key ②.
4. Rotate the FREQUENCY dial ④ clockwise until the second digit from the right ⑥ is 5.
5. Press the FINE key ③.
6. Rotate the FREQUENCY dial ④ clockwise until the right-most digit ⑦ is 5.

Figure 3-3. Spot Frequency Setting Procedure.

PARTIAL SWEEP MEASUREMENT

To make a PARTIAL sweep measurement, use the procedure given below :

PROCEDURE :

1. Connect the probe to the sample.
2. Select the desired START frequency. Refer to Figure 3-3 for the procedure.
3. Press the ENTER key. The indicator lamp in the center of the key will come on.
4. Press the START FREQ. key. The ENTER key indicator lamp will go off.
5. Select the desired STOP frequency. Refer to Figure 3-3 for the procedure.
6. Press the ENTER key. The indicator lamp in the center of the key will come on.
7. Press the STOP FREQ. key. The ENTER key indicator lamp will go off.
8. Press the 100, 1000, or HIGH RES STEPS key to select the number of measurement points. Refer to paragraph 3-19.
9. Press the PARTIAL SWEEP START/ABORT key to start the sweep. The indicator lamp in the center of the key will come on. To stop the sweep, press the PARTIAL SWEEP START/ABORT key. The indicator lamp will go off and the sweep will stop immediately.

Note

If the STOP frequency is lower than the START frequency, E-80 will be displayed on the FREQUENCY display when the PARTIAL SWEEP START/ABORT key is pressed.

Note

If the step frequency is too low for the selected frequency range, the 4193A automatically selects an acceptable step frequency. If, for example, the START frequency is 500kHz, the STOP frequency is 600kHz, and 1000 STEPS is selected, the 4193A automatically selects 100 steps. The 1000 STEPS indicator lamp remains on, however. This automatic adjustment can also occur during a sweep when the frequency is swept over a frequency resolution change point; that is, 10MHz and 100MHz.

Note

Manual PARTIAL sweep can be performed by pressing the MANUAL TRIGGER key.

Figure 3-4. PARTIAL Sweep Measurement.

FULL SWEEP MEASUREMENT

To make a FULL sweep measurement, use the procedure given below :

PROCEDURE :

1. Connect the probe to the sample.
2. Press the FULL SWEEP START/ABORT key. The indicator lamp in the center of the key will come on and the sweep will begin. To stop the sweep, press the FULL SWEEP START/ABORT key. The indicator lamp will go off and the sweep will stop immediately.

The FULL sweep measurement points are listed below :

400kHz, 455kHz, 500kHz, 600kHz, 700kHz, 800kHz, 900kHz, 1MHz, 1.2MHz, 1.4MHz, 1.6MHz, 1.8MHz, 2MHz, 2.333MHz, 2.666MHz, 3MHz, 3.5MHz, 4MHz, 4.5MHz, 5MHz, 6MHz, 7MHz, 8MHz, 9MHz, 10MHz, 12MHz, 14MHz, 16MHz, 18MHz, 20MHz, 23.33MHz, 26.66MHz, 30MHz, 35MHz, 40MHz, 45MHz, 50MHz, 60MHz, 70MHz, 80MHz, 90MHz, 100MHz, 110MHz.

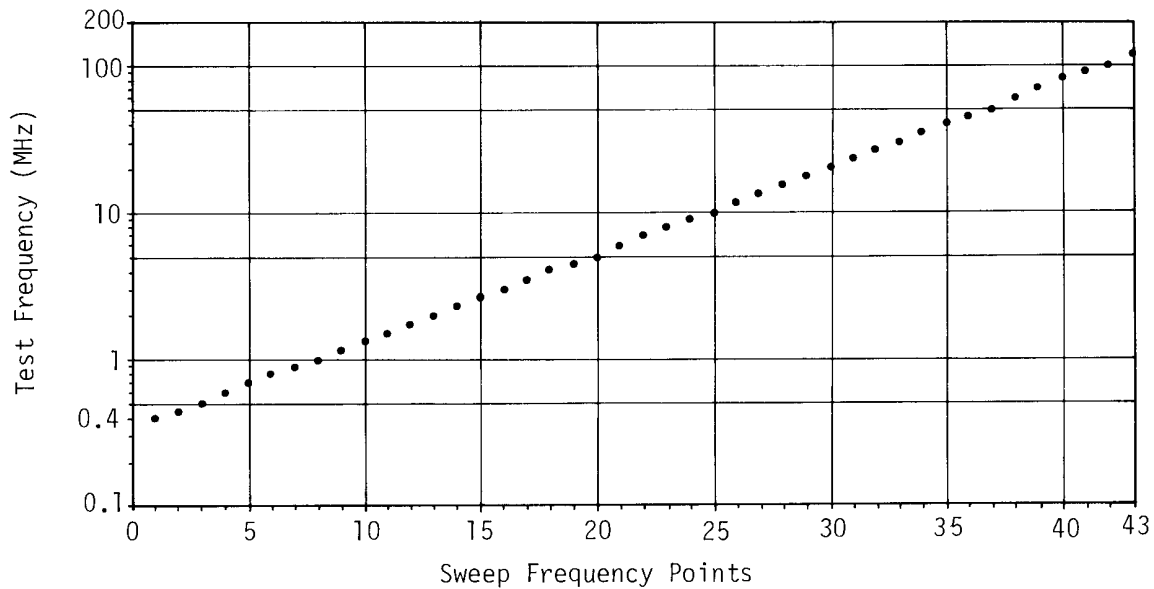

Note

Manual FULL sweep can be performed by pressing the MANUAL TRIGGER key.

Figure 3-5. FULL Sweep Measurement.

3-23. DISPLAYS

3-24. The 4193A has three display sections : MAGNITUDE, PHASE, and FREQUENCY. They are described in paragraphs 3-25 through 3-27, respectively.

3-25. The MAGNITUDE display provides direct readout of measured impedance magnitude with 3 1/2-digit display resolution. The actual number of display digits depends on the measurement range. Maximum number of counts on the 10 Ω , 100 Ω , 1k Ω , and 10k Ω ranges is 1999, and 120 on the 100k Ω range. The least significant digit on the 100k Ω range may be displayed as "  " indicating that the least significant digit is meaningless. Five over-range annunciations are also displayed on this display. Refer to Table 3-4.

3-26. The PHASE display provides direct readout of measured phase angle with 3 1/2-digit display resolution. Maximum number of counts is 1800. When measurement is made on the 100k Ω range, the least significant digit of measured phase values may be displayed as "  " indicating that the least significant digit is meaningless. Also, when an over-range occurs on the MAGNITUDE display or when the measured magnitude is less than 20 counts, " - - - - " will be displayed on the PHASE display.

3-27. The FREQUENCY display provides direct readout of SPOT, START, and STOP frequencies with 4-digit display resolution. Error-codes related to mis-operation and instrument failure are also displayed here. Refer to paragraph 3-28.

3-28. Error-Code and Over-range Annunciations

3-29. Error-codes related to mis-operation and over-range annunciations are listed, along with a brief description, in Tables 3-3 and 3-4, respectively. Error codes related to SELF TEST and instrument failure are listed in Table 3-5. If an error listed in Table 3-5 should occur, contact the nearest Hewlett-Packard Sales/Service Office.

3-30. INITIAL DISPLAY TEST

3-31. All display segments and indicator lamps are lit for approximately one second each time the instrument is turned on. If a display segment or indicator lamp fails to light or does not light properly, it must be replaced.

Table 3-3. Operational Error-codes





Error-code	Meaning
	Lower-left key () or upper-right key () was pressed or selected via the HP-IB with the X-Y RECORDER function set to ON and TRIGGER set to INT.
	The HP-IB Address Control Switch is set to address 31 (11111). Only addresses 0 (00000) through 30 (11110) are allowed.
	STOP FREQ. is lower than the START FREQ. in PARTIAL SWEEP operation.

Table 3-4. Annunciations

MAGNITUDE Display	PHASE Display	Meaning	Treatment
0r 1	----	Measured impedance magnitude value exceeds the upper limit of 10 Ω range (Range 1).	Change the MAGNITUDE range to range 2.
0r 2	----	Measured impedance magnitude value exceeds the upper limit of 100 Ω range (Range 2).	Change the MAGNITUDE range to 3.
0r 3	----	Measured impedance magnitude value exceeds the upper limit of 1k Ω range (Range 3).	Change the MAGNITUDE range to 4.
0r 4	----	Measured impedance magnitude value exceeds the upper limit of 10k Ω range (Range 4).	Change the MAGNITUDE range to 5.
0r 5	----	Measured impedance magnitude value exceeds the upper limit of 100k Ω range (Range 5).	

Table 3-5. SELF TEST Error-codes

Code	Description
E-01	A17U1 (RAM) is faulty.
E-02	A17U2 (RAM) is faulty.
E-03	A17U3 (ROM) is faulty.
E-04	A17U4 (ROM) is faulty.
E-05	A17U5 (ROM) is faulty.
E-06	A17U6 (ROM) is faulty.
E-07	A17U7 (ROM) is faulty.
E-30	A13 Detection board is not functioning properly.
E-40	A14 ADC board is not functioning properly.
E-41	A17 Control Logic board is not functioning properly.
E-60	A16 HP-IB board is not functioning properly.
E-70	A17 Control Logic board is not functioning properly.
E-71	A17 Control Logic board is not functioning properly.

3-32. EXTERNAL TRIGGERING

3-33. The 4193A can be externally triggered by connecting a trigger device to the EXT TRIGGER connector on the rear-panel. The instrument is triggered (measurement is made) each time a low-going TTL level pulse is applied to this connector or each time the center conductor is shorted and opened to ground. The instrument must be set to the MAN/EXT trigger mode for external trigger operation.

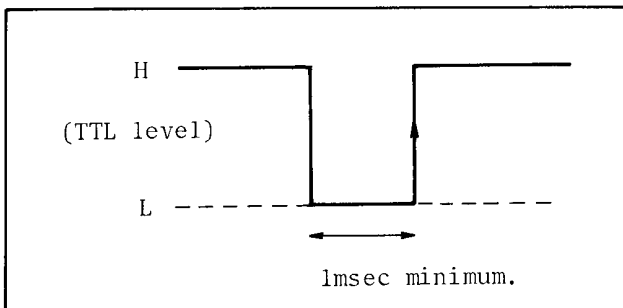

Figure 3-6. External Trigger Pulse.

3-34. MEASUREMENT TIME

3-35. Measurement time for a given DUT is approximately 1s in normal speed mode and 150ms in high speed mode, with the X-Y RECORDER off and the test frequency constant. Additional time is required when the test frequency is changed, the DUT is changed, or the measurement range is changed. Refer to Table 3-6 for typical values.

Table 3-6. Additional Measurement Times

	Typical Time	Remarks
Freq. Settling Time	100ms (5ms to 400ms)	Changing frequency.
Wait Time	200ms	Changing DUT.
Ranging Time	1.2s	Ranging up or down one range.

3-36. USE OF FURNISHED PROBE ADAPTERS

3-37. Four probe adapters are furnished to facilitate connection to a wide range of DUT types. Each probe adapter is listed in Table 3-7.

Table 3-7. Furnished Probe Adapters

Adapter	HP Part No.
BNC Adapter	04193-61152
Component Adapter	04193-61153
Ground Adapter	04193-61154
Probe Socket	04193-21008

3-38. The BNC Adapter is provided for input and output impedance measurements on circuits equipped with BNC female connectors. The Component Mounting Adapter is used for measurements on discrete axial- or radial-lead component. The Probe Socket is for user-fabricated test fixtures, as shown in Figure 3-7. It is available for supporting the probe, which is attached to the user-built fixture and is connected to ground.

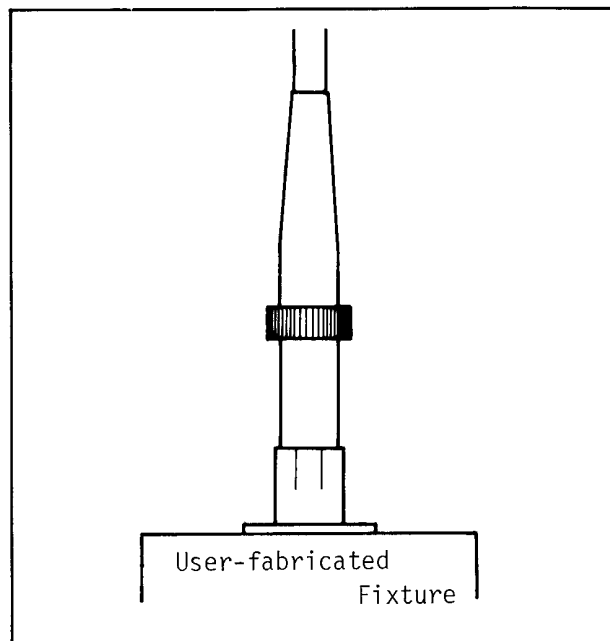

Figure 3-7. Probe Socket Usage.

3-39. PROBE

3-40. The instrument is adjusted to meet the specifications listed in Table 1-1, with the furnished probe connected. If the probe (HP P/N 04193-61151) is replaced or repaired, the adjustments described in Section VIII must be performed. For information on probe replacement or repair, contact the nearest Hewlett-Packard Sales/Service Office.

CAUTION

DO NOT CONNECT THE PROBE TO A COMPONENT OR CIRCUIT THAT HAS A DC BIAS EXCEEDING 50V OR AN AC VOLTAGE EXCEEDING 5V RMS. TO DO SO MAY DAMAGE THE INSTRUMENT.

Note

To ensure measurement accuracy, make sure that the coupling nuts, probe barrel, and probe tip are firmly tightened.

SECTION III

3-41. Probe and Test Fixture Residuals

3-42. The equivalent circuit of the 4193A's measurement port is shown in Figure 3-8. All measured values displayed on the MAGNITUDE and PHASE displays include the residuals of the probe and the test fixture. Typical values of each residual are listed in Table 3-8.

3-43. The conductive component of the open-circuit admittance of the equivalent circuit shown in Figure 3-8 is sufficiently larger than the susceptive component, c , at the frequencies below 110MHz to be negligible.

3-44. Residuals compensation can be made using the following procedure :

- (1). Connect nothing to the test fixture (or probe) and note the value displayed as Z_o .
- (2) Short the test fixture (or probe) and note the value displayed as Z_s .
- (3) Calculate the DUT's actual impedance using the equation given in Figure 3-9.

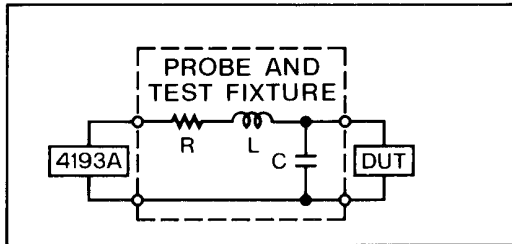

Figure 3-8. Equivalent Circuit.

Table 3-8. Typical Residuals at 100MHz

PROBE AND TEST FIXTURE	R (Ω)	L (nH)	C (pF)
PROBE + 16099A	0.5	10	2.4
PROBE + 16099A + 16092A	0.5	11	3.5
PROBE + 16099A + 16093A	0.5	12	4.2
PROBE + 16099A + 16093B	0.5	12	7.9

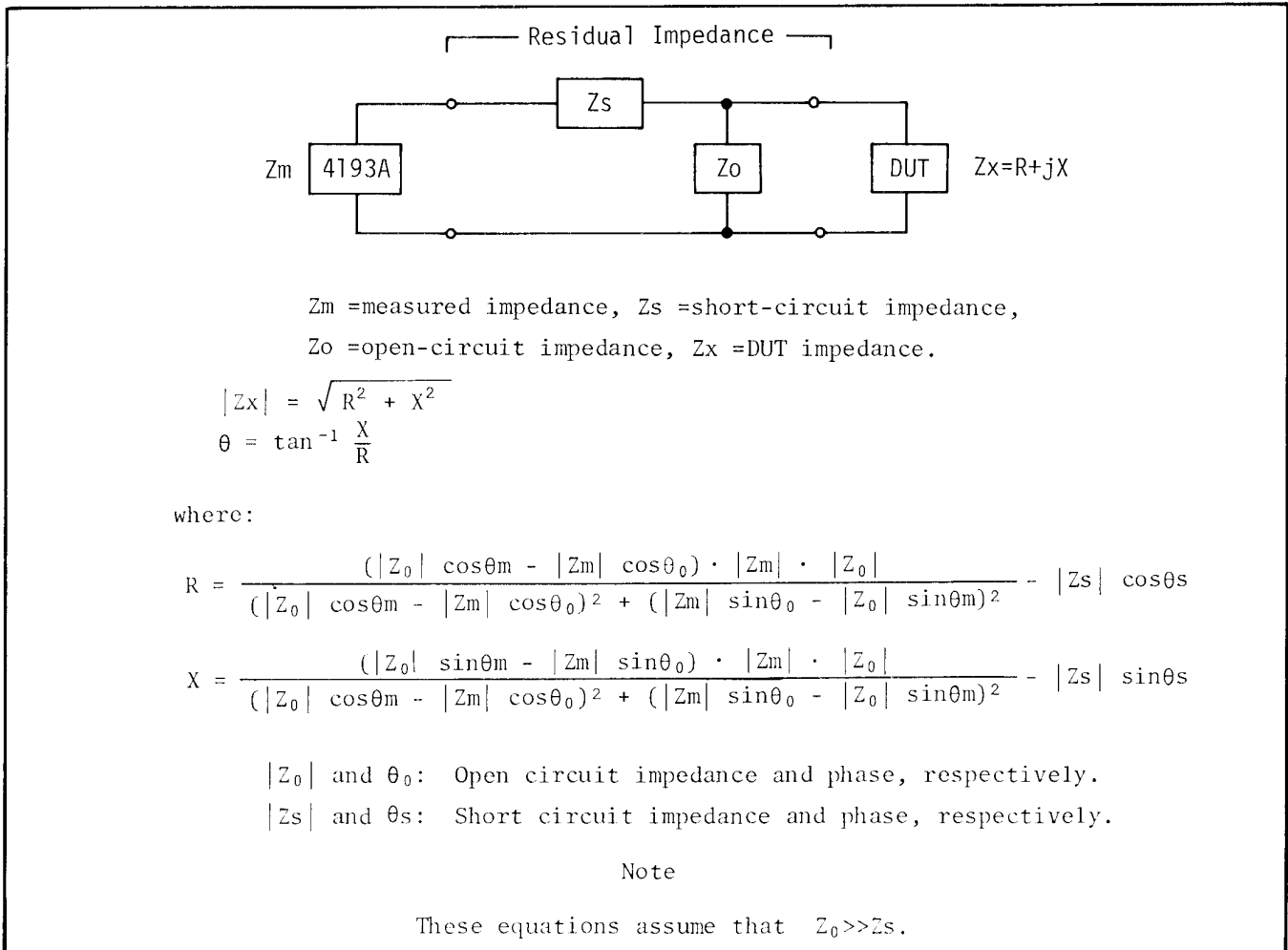

Figure 3-9. Residuals Compensation.

SECTION III

3-45. EXTERNAL OSCILLATOR

3-46. An external signal source (output impedance: $50\Omega \pm 10\%$) can be connected to the EXT. OSC. connector on the rear-panel to obtain higher test signal resolution than is possible with the 4193A's internal signal source. This feature makes it possible to measure high-Q devices such as crystals. A maximum test signal resolution of 100Hz is possible when an external signal source is used. The external oscillator controls frequency only; the 4193A controls the level of the test signal applied to the DUT. The level of the external signal must be from 0 to 5dB. When the external signal source is connected to the 4193A, the EXT. OSC. indicator lamp on the front-panel comes on automatically. The difference between the 4193A's test signal frequency setting and that of the external signal source's should not exceed 10MHz. For best results the 4193A's test signal frequency should be set as close as possible to that of the external signal source.

3-47. X-Y RECORDER OUTPUT

3-48. The 4193A is equipped with three analog output connectors on the rear-panel (MAGNITUDE, PHASE, FREQUENCY) which output DC voltages proportional to the displayed magnitude, phase, and frequency values. These connectors can be connected to an X-Y Recorder to plot the impedance/frequency or phase/frequency characteristics of the sample impedance. A PEN LIFT connector is also provided for use with X-Y Recorders equipped with remote pen-lift control.

3-49. ANALOG MAGNITUDE OUTPUT

3-50. DC voltage output from the MAGNITUDE connector is proportional to the number of counts displayed on the MAGNITUDE display. Output voltage is calculated as:

$$V_M = \frac{C_M}{2000} \text{ (Volts)}$$

where V_M is the analog output voltage and C_M is the number of counts displayed on the MAGNITUDE display. When C_M is 2000 counts (full-scale), for example, V_M is +1 volt. MAGNITUDE output voltage range is 0 to 1 volt.

Note

If the sample's impedance is higher than the full-scale limit of the selected range, **0 r -** N (N represents the magnitude range: 1 = 10Ω range, 2 = 100Ω range, 3 = $1k\Omega$ range, 4 = $10k\Omega$ range, 5 =

$100k\Omega$ range) will be displayed on the MAGNITUDE display and the analog output voltage will be 1 volt.

3-51. ANALOG PHASE OUTPUT

3-52. DC voltage output from the PHASE connector is proportional to the number of counts displayed on the PHASE display. Output voltage is calculated as:

$$V_p = \frac{C_p}{1800} \text{ (Volts)}$$

where V_p is the analog output voltage and C_p is the number of counts (with sign) displayed on the PHASE display. When C_p is 1800 counts (full-scale positive), for example, V_p is +1 volt; conversely, when C_p is -1800 counts (full-scale negative), V_p is -1 volt. PHASE output voltage range is 0 to ± 1 volt.

Note

The above equation is valid even when " - - - " is displayed on the PHASE display. The last valid phase value is used for C_p in this case.

3-53. ANALOG FREQUENCY OUTPUT

3-54. DC voltage output from the FREQUENCY connector is proportional to the displayed frequency, but is different for each sweep mode. Output voltage is calculated as:

For PARTIAL SWEEP:

$$V_F = \frac{f_{SPOT} - f_{START}}{f_{STOP} - f_{START}} \text{ (Volts)}$$

For FULL SWEEP:

$$V_F = \frac{\log(f_{SPOT}/f_{START})}{\log(f_{STOP}/f_{START})} \text{ (Volts)}$$

where V_F is the analog output voltage and f_{SPOT} , f_{START} , and f_{STOP} are, respectively, the test frequency displayed the FREQUENCY display, the sweep START frequency, and the sweep STOP frequency. All frequencies are in MHz.

Note

When neither sweep mode is selected (SPOT Measurement), the output voltage is calculated using the PARTIAL SWEEP equation.

IN-CIRCUIT IMPEDANCE MEASUREMENT

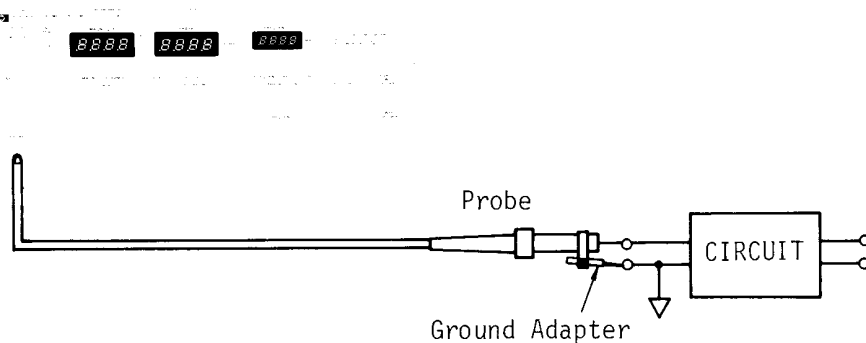

SETUP :

Attach the furnished slide-on ground adapter (HP Part No. : 04193-61154) to the probe barrel, as shown in the figure.

PROCEDURE :

1. Turn on the instrument and verify that it passes the initial display test and that "PASS" is displayed on the FREQUENCY display at the completion of the SELF TEST.
2. Set the desired test frequency by rotating the Frequency Control Dial, as described in Figure 3-3.
3. Connect the probe center pin and the ground pin to the sample circuit terminals as shown above. If the ground pin is too short to reach the sample circuit's ground terminal, use the furnished ground lead (HP Part No. : 04193-61629), as shown below :

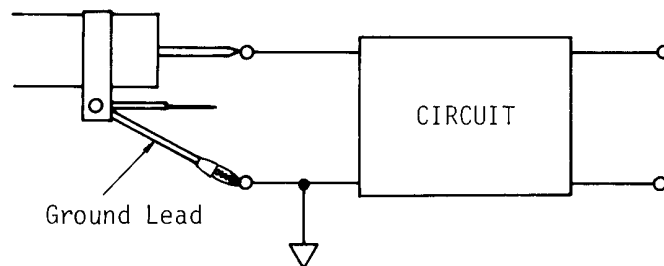

CAUTION

DO NOT CONNECT THE PROBE TO A CIRCUIT THAT HAS A DC BIAS EXCEEDING 50V OR AN AC VOLTAGE EXCEEDING 5V RMS. TO DO SO MAY DAMAGE THE INSTRUMENT.

Note

The circuit terminal distance should be as short as possible.

Note

The residual impedance of the ground adapter is less than that of the ground lead.

Note

The probe pin (HP Part No. : 16095-60012) and the ground pin (HP Part No. : 0360-2066) are replaceable.

Figure 3-10. In-circuit Impedance Measurement Procedure.

GENERAL COMPONENT MEASUREMENT

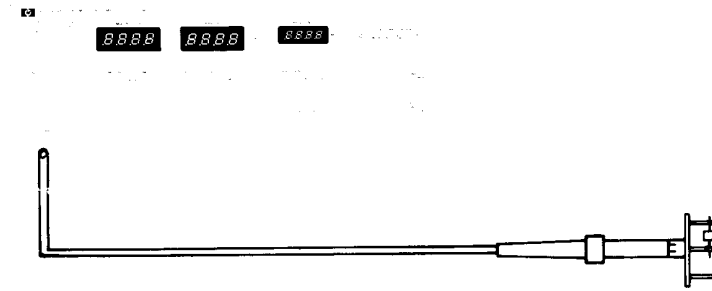

SETUP :

Attach the furnished component adapter (HP Part No. : 04193-61153) to the end of the probe, as shown in the figure.

PROCEDURE :

1. Turn on the instrument and verify that it passes the initial display test and that "PASS" is displayed on the FREQUENCY display at the completion of the SELF TEST.
2. Set the desired test frequency by rotating the Frequency Control Dial, as described in Figure 3-3.
3. Connect the DUT between the center terminal and one of the outer terminals of the component adapter, as shown in the figure.
4. Read the measured impedance and phase displayed on the MAGNITUDE and PHASE displays, respectively.

CAUTION

DO NOT CONNECT THE PROBE TO A COMPONENT THAT HAS A DC BIAS EXCEEDING 50V OR AN AC VOLTAGE EXCEEDING 5V RMS. TO DO SO MAY DAMAGE THE INSTRUMENT.

Note

The component adapter dimensions are shown below. The terminals (HP Part No. : 04193-60151) are replaceable.

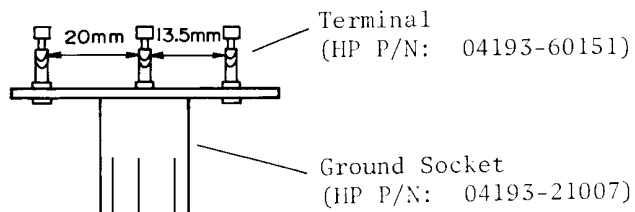

Note

For measurement of components that cannot be connected to the component adapter, the 16092A/16093A/16093B test fixtures are available. Refer to Table 1-4.

Figure 3-11. General Component Measurement Procedure.

EXTERNAL OSCILLATOR USAGE

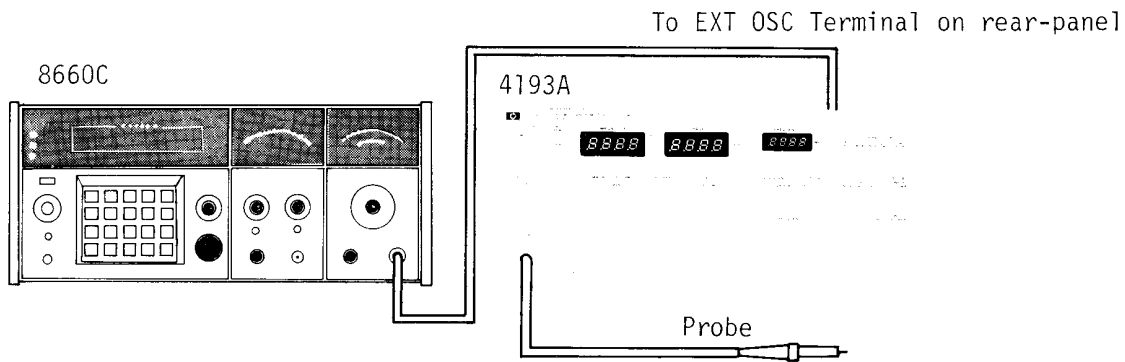

EQUIPMENT :

- Synthesized Signal Generator Generator with 86633B and 86601B
 TYPE N (male)-BNC (female) Adapter HP P/N :1250-1535
 BNC (male)-BNC (male) Cable HP 10503A

PROCEDURE :

1. Turn off both instruments.
2. Connect the synthesizer's RF section to the 4193A's EXT. OSC. connector, as shown in the figure.
3. Set the synthesizer's output level to 0dBm.

Note

DO NOT allow the synthesizer's output level to exceed +5dBm. To do so may damage the 4193A.

4. Turn on both instruments.
5. Confirm that the EXT. OSC. indicator lamp on the 4193A's front-panel comes on after completion of the initial SELF TEST.
6. Connect the probe to the device or circuit under test and set the instruments' controls as appropriate for the measurement. For best results, set the 4193A's test frequency as close as possible to the synthesizer's frequency.

Note

The maximum allowable difference between the 4193A's test frequency setting and the external synthesizer's setting is 10MHz.

Note

Maximum obtainable frequency resolution for measurements using an external frequency synthesizer is approximately 100Hz over the 4193A's full frequency range, 400kHz to 110MHz.

Figure 3-12. External Oscillator Usage Procedure.

X-Y RECORDER SETUP

EQUIPMENT :

X-Y RECORDER HP 7046A
 BNC (male)-Dual Banana Plug Cable HP11001A (4 ea.)

PROCEDURE

1. Turn off the 4193A's X-Y RECORDER function--X-Y RECORDER ON/OFF indicator lamp should be off.
2. Locate the 4193A's X-Y RECORDER OUTPUTS on the rear-panel (see Figure 3-2) and connect FREQUENCY to the recorder's X-axis, MAGNITUDE to the Y1-axis, PHASE to the Y2-axis, and PEN LIFT to the recorder's REMOTE PEN jack (rear-panel).
3. Place the chart paper on the recording platen and set the CHART switch to the HOLD Position. PEN switch should be set to LIFT.
4. Press the \downarrow LL key on the 4193A and, referring to Figure A, position pen 1 at the black dot (•) and pen 2 at the cross (x).
5. Press the UR \rightarrow key on the 4193A and, referring to Figure A again, position both pens at the circle (o).

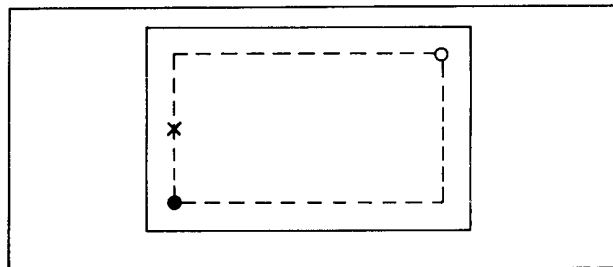

Figure A. Plot Area of RECORDER OUTPUTS.

Note

On some X-Y Recorders, zero and full-scale adjustments may be interactive. Repeat steps 4 and 5, if necessary.

6. Connect the probe to the device or circuit under test and set the 4193A's controls as appropriate for the measurement.
7. Perform one swept measurement with the X-Y RECORDER function set to OFF and note the measurement range at which the DUT's impedance is highest.
8. Using the MANUAL MEASUREMENT RANGE keys, \square and \square , set the 4193A's measurement range to the range noted in step 7.
9. Press the X-Y RECORDER ON/OFF key--indicator lamp will come on--and press the PARTIAL SWEEP or FULL SWEEP key to start the plot.

Note

The above procedure is for 2-pen recorders equipped with remote pen-lift control. For single-pen recorders and recorders not equipped with remote pen-lift control, the above procedure must be modified slightly.

Figure 3-13. X-Y Recorder Usage Procedure.

SECTION III

3-55. HP-IB COMPATIBILITY

3-56. The 4193A can be remotely controlled via the HP-IB, a carefully defined instrument interface which simplifies integration of instruments and a calculator or computer into a system.

Note

HP-IB is Hewlett-Packard's implementation of IEEE Std. 488, Standard Digital Interface for Programmable Instrumentation.

3-57. HP-IB INTERFACE CAPABILITIES

3-58. The 4193A has eight HP-IB interface functions, as listed in Table 3-9.

3-59. CONNECTION TO HP-IB

3-60. The 4193A can be connected into an HP-IB bus configuration with or without a controller (i.e., with or without an HP calculator). In an HP-IB system without a controller, the instrument functions as a "talk only" device.

3-61. HP-IB CONTROL SWITCH

3-62. The HP-IB Control Switch, located on the rear panel, has seven bit switches as shown in Figure 3-14. Each bit switch has two settings: logical 0 (left position) and logical 1 (right position). Bit switch 7 determines whether the instrument will be addressable by the controller

in a multi-device system, or will function as a "talk only" device to output measurement data and/or instructions to an external "listener," e.g., printer or plotter.

When bit switch 7 is set to 0, the instrument is in ADDRESSABLE mode and bit switches 1 through 5 determine the instrument address; when this switch is set to 1, the instrument is in TALK ONLY mode.

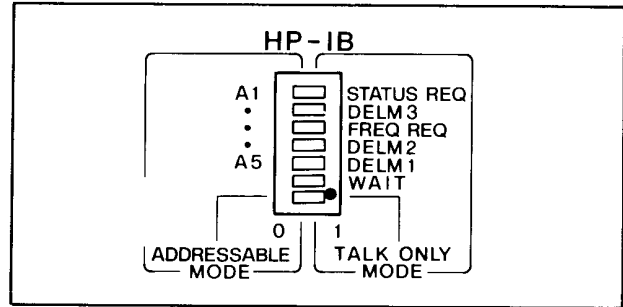

Figure 3-14. HP-IB Control Switch.

3-63. ADDRESSABLE MODE

3-64. When bit switch 7 is set to ADDRESSABLE (i.e., set to 0), bit switches 1 through 5 represent the HP-IB address of the instrument, in binary. These switches are set to 10001 (decimal 17) when the instrument leaves the factory but can be set to any desired address between 0 and 30. Bit switch 6 has no meaning in this mode. The HP-IB Control Switch, set to the ADDRESSABLE mode and with the factory address setting, is shown in Figure 3-15.

Table 3-9. HP-IB Interface Capabilities

Code	Interface Function* (HP-IB Capabilities)
SHI**	Source Handshake
AHl	Acceptor Handshake
T5	Talker (basic talker, serial poll, talk only mode, unaddress to talk if addressed to listen)
L4	Listener (basic listener, unaddress to listen if addressed to talk)
SRl	Service Request
RLl	Remote/Local (with local lockout)
DCl	Device Clear
DTl	Device Trigger

* Interface functions provide the means for a device to receive, process, and transmit messages over the bus.

** The suffix number of the interface code indicates the limitation of the function capability as defined in Appendix C of IEEE STD. 488.

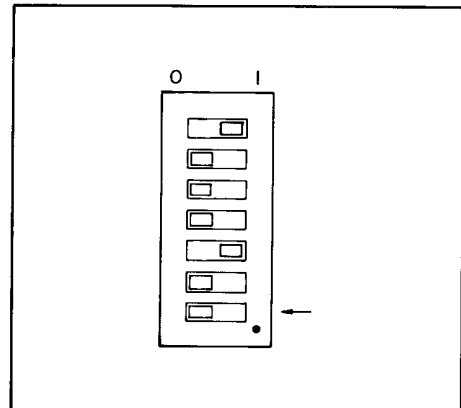
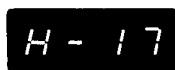

Figure 3-15. ADDRESSABLE Mode.

Note

When the instrument is turned on, the address is displayed on FREQUENCY display after the SELF TEST. If the address switches are set to 10001, the display is as shown below :

FREQUENCY



3-65. TALK ONLY MODE

3-66. When bit switch 7 is set to TALK ONLY (i.e., set to 1) as shown in Figure 3-16, the other bit switches, 1 through 6, function as described in Table 3-10.

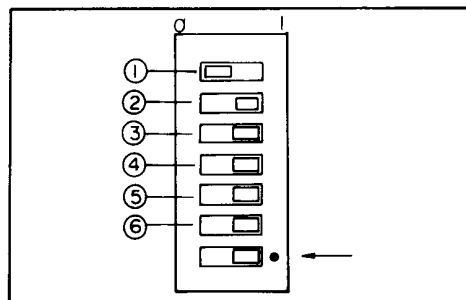

Figure 3-16. TALK ONLY Mode.

Table 3-10. Functions of Bit Switches ① through ⑥

Bit Switch	Name	Function When Set to 1	Function When Set to 0
⑥	WAIT	After a measurement, the 4193A waits until all measurement data has been received by the listener before proceeding to the next measurement, even in internal trigger mode.	After a measurement, the 4193A proceeds to the next measurement regardless of whether the listener has received all the measurement data or not.
⑤	DELM1	Selects (CR) (LF) as the Delimiter for the magnitude field.* When a printer is connected to the 4193A, this delimiter causes the printer to perform a carriage return and a line feed.	Selects the comma "," as the delimiter for the magnitude field.* The printer does not perform a carriage return or line feed.
④	DELM2	Selects (CR) (LF) as the delimiter for the phase field.* This delimiter causes the printer to perform a carriage return and a line feed.	Selects the comma "," as the delimiter for the phase field.* The printer does not perform a carriage return or line feed.
③	FREQ REQ	Specifies that frequency data be output along with magnitude and phase data.	Frequency data is not output.
②	DELM3	Selects (CR) (LF) as the delimiter for the frequency field.* This delimiter causes the printer to perform a carriage return and a line feed.	Selects the comma "," as the delimiter for the frequency field.* The printer does not perform a carriage return or line feed.
①	STATUS REQ	Specifies that status data be output along with magnitude and phase data.	Status data is not output.

* Refer to para. 3-71, Data Output.

SECTION III

3-67. HP-IB STATUS INDICATORS

3-68. The HP-IB Status Indicators are four LED lamps located on the front panel. When lit, these lamps show the existing status of the 4193A in the HP-IB system as follows :

- SRQ : SRQ signal from the 4193A to the controller is on the HP-IB line. Refer to paragraph 3-77.
- LISTEN : The 4193A is set to listener.
- TALK : The 4193A is set to talker.
- REMOTE : The 4193A is remotely controlled.

3-69. LOCAL KEY

3-70. The LOCAL key releases the 4193A from HP-IB remote control and allows measurement conditions to be set from the front panel. The REMOTE lamp will go off when this key is pressed. LOCAL control is not available when the 4193A is set to "local lockout" status by the controller.

3-71. DATA OUTPUT

3-72. Measurement and status data are output to external devices in bit parallel, byte serial format via the eight DIO signal lines of the HP-IB. These data consist of impedance magnitude and phase data, test frequency data, and key status data. Magnitude and phase data are always output, but output of test frequency data and key status data depends on the program (ADDRESSABLE), or the setting of the HP-IB Control Switch on the rear panel, refer to Table 3-10. All characters are coded in accordance with ASCII coding conventions.

[1] Impedance Magnitude Data Field

This field contains READY/NOT READY information and the value of the measured impedance.

$$\frac{Y_x^*, S_x, ZM_{xxxxx} E_x}{(1) (2) (3) (4) (5)}$$

* x represents single digit, variable numeric data.

- (1) Status of measurement : Y0 = NOT READY, Y1 = READY.
- (2) Status of magnitude data : S0 = less than 18 counts, S1 = less than 180 counts, S2 = 180 to 2000 counts, S3 = over range, S4 = Er - 40 or Er - 41, S5 = Er - 30, S6 = Er - 30 and Er - 40.
- (3) Magnitude display counts.
- (4) Unit : E0 = Ω, E3 = kΩ
- (5) Delimiter: comma in ADDRESSABLE mode. In TALK ONLY mode, (CR) (LF) or a comma depending on the setting of bit switch 5 on the HP-IB Control Switch. Refer to Table 3-10.

[2] Impedance Phase Data Field

This field contains the phase of the measured impedance.

$$\frac{ZPs^*xxx.x}{(1) (2)}$$

* s represents the sign (+ or -).

- (1) Sign and magnitude with decimal point of the measured phase.
- (2) Delimeter : See [1].

[3] Frequency Field

This field contains test frequency information.

$$\frac{W_x, B_x, FR_{xxxxx} E_x, P_x, Q_x}{(1) (2) (3) (4) (5) (6) (7)}$$

- (1) Sweep mode : W1 = partial sweep, W2 = full sweep, W3 = last frequency in sweep measurement, W4 = spot measurement.
- (2) Oscillator : B0 = Internal oscillator, B1 = External oscillator.
- (3) Frequency display counts.
- (4) Unit : E6 = MHz
- (5) Partial sweep step : P1 = 100, P2 = 1000, P3 = HIGH RESOLN.

(6) Frequency resolution : Q1 = COARSE, Q2 = MED, Q3 = FINE.

(7) Delimiter : See [1].

[4] Status Field

This field contains key status data (front panel control settings).

$\frac{A_x, R_x, H_x, T_x, X_x, I_x, G_x, D_x}{(1) (2) (3) (4) (5) (6) (7) (8)}$

- (1) Magnitude range mode : A0 = HOLD, A1 = AUTO.
- (2) Magnitude range : R1 = 10 Ω , R2 = 100 Ω , R3 = 1k Ω , R4 = 10k Ω , R5 = 100k Ω .
- (3) High speed mode : H0 = OFF, H1 = ON.
- (4) Trigger mode : T1 = INT, T2 = HOLD.
- (5) X-Y Recorder ON/OFF : X0 = OFF, X1 = ON.
- (6) Interpolation : I0 = OFF, I1 = ON.
- (7) External trigger : G0 = Disable, G1 = Enable.
- (8) Data ready : D0 = SRQ OFF, D1 = SRQ ON.

3-73. OUTPUT DATA FORMAT

3-74. There are four output data formats available on the 4193A, as listed in the table below. The format is determined by the HP-IB program (ADDRESSABLE mode). For TALK ONLY mode, see Table 3-10.

3-75. Programming Guide for the 4193A

3-76. Sample programs that can be run on the Model 9825A or HP-85 Desktop Computer are given in Figures 3-19 and 3-20.

Note

Specific information on HP-IB programming with the 9825A and HP-85 can be found in the programming manual of each computer.

Following equipment are required to run the sample programs :

- (1) 4193A Vector Impedance Meter
- (2) 98034A/B HP-IB Interface Card
- (3) 9825A Desktop Computer with 98210A String-Advanced Programming ROM and 98213A General I/O-Extended I/O ROM, or 9825B/T.

or

- (2) 82937A HP-IB INTERFACE
- (3) HP-85 Personal Computer with 00085-15003 INPUT/OUTPUT ROM.

3-77. SERVICE REQUEST STATUS BYTE

3-78. The 4193A outputs an RQS (Request Service) signal whenever it is set to one of the six possible service request states. Figure 3-17 shows the contents of the Status Byte.

Bit 7 (RQS) indicates whether or not a service request exists. Bit 8 is always zero (0). Bits 1 through 6 identify the type of service request. Following are the service request states of the 4193A.

Table 3-11. Output Data Format

Format	Fields Output			
	Magnitude	Phase	Freq.	Status
FMT1	Yes	Yes	No	No
FMT2	Yes	Yes	Yes	No
FMT3	Yes	Yes	No	Yes
FMT4	Yes	Yes	Yes	Yes

SECTION III

(1) Bit 6 : Set when no syntax error but program is inoperative as follows :

(1) During PARTIAL/FULL SWEEP:

Changing SPOT FREQ. (FR x EN)

Executing LL, UR when X-Y RECORDER OUTPUT is ON

Executing SELF TEST (S1)

(2) During PARTIAL SWEEP :

Changing STEPS (P1, P2, P3)

(3) When X-Y RECORDER OUTPUT is OFF:

Executing INTRPL (I0, I1)

(4) When X-Y RECORDER OUTPUT is ON and TRIGGER is INT:

Executing Lower Left (LL) or Upper Right (UR)

(2) Bit 5 : Indicates the result of the SELF TEST; 0 = FAIL, 1 = PASS.

(3) Bit 4 : Set when the 4193A is externally triggered before data has been completely output in REMOTE state.

(4) Bit 3 : Set when SELF TEST is completed.

(5) Bit 2 : Set when the remote program contains a syntax error.

(6) Bit 1 : Set when measured data is valid, independent of "D0" or "D1" setting.

3-79. PARAMETER SETTING

3-80. SPOT FREQUENCY and PARTIAL SWEEP START and STOP frequencies are set via remote programming, as follows :

SPOT FREQUENCY : $\frac{FR}{(1)} \times \frac{EN}{(2)(3)}$

PARTIAL SWEEP

START FREQUENCY : $\frac{TF}{(1)} \times \frac{EN}{(2)(3)}$

STOP FREQUENCY : $\frac{PF}{(1)} \times \frac{EN}{(2)(3)}$

(1) Parameter program code

(2) Four digit (max.) number between 0.400 and 110.0; the unit is MHz.

(3) Parameter terminator

8 MSB	7	6	5	4	3	2	1 LSB
	SRQ	Prog. logic error	Self test result	Trig. too fast	Self test end	Syntax error	Data ready

Figure 3-17. Status Byte.

Table 3-12. REMOTE PROGRAM CODE

FUNCTION	CONTROL	CODE	DESCRIPTION
FREQUENCY RESOLUTION	COARSE MED FINE	Q1 Q2 Q3*	
AUTO MAGNITUDE RANGE	OFF ON	A0 A1*	
MAGNITUDE RANGE	10 Ω range 100 Ω range 1k Ω range 10k Ω range 100k Ω range	R1 R2 R3 R4 R5	00.00 - 19.99 Ω 000.0 - 199.9 Ω 0.000 - 1.999k Ω 00.00 - 19.99k Ω 000. - 120. k Ω
HIGH SPEED MODE	OFF ON	H0* H1	>1 measurement/second =3 - 10 measurement/second
SWEEP STEP	100 steps 1000 seeps HIGH RESOLUTION	P1* P2 P3	Sweep the least significant digit by 1 count.
AUTO SWEEP	PARTIAL SWEEP START FULL SWEEP START SWEEP ABORT	W1 W2 W3	For both PARTIAL and FULL sweep.
TRIGGER	INTERNAL MAN/EXT	T1* T2	Specifies MAN/EXT trigger mode.
EXECUTE		EX	Triggers the 4193A.
EXTERNAL TRIGGER	OFF ON	G0 G1*	Disables external trigger. Enables external trigger.
RECORDER OUTPUT	OFF ON LOWER LEFT UPPER RIGHT	X0* X1 LL UR	
INTERPOLATION	OFF ON	I0* I1	
SELF TEST	OFF ON	S0* S1	
DATA READY SRQ	OFF ON	D0* D1	Outputs SRQ when data is measured.
OUTPUT DATA FORMAT		FMT1* FMT2 FMT3 FMT4	STANDARD FIELD* output only. STANDARD + FREQUENCY FIELD* output. STANDARD + STATUS FIELD* output. STANDARD + FREQUENCY + STATUS FIELD output.
CANCEL DATA		CL	

*: Default code.

*: See para. 3-71 Output Data.

SECTION III

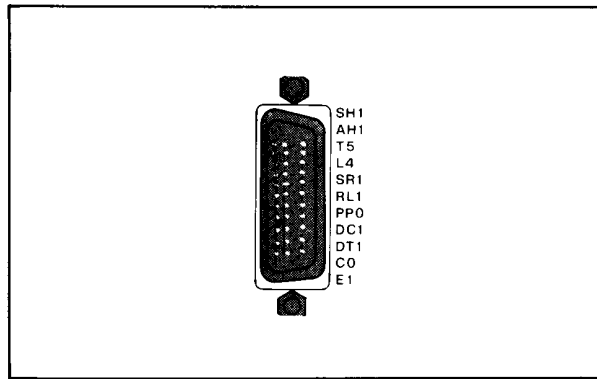

Figure 3-18. HP-IB Connector.

Sample Program 1

PURPOSE :

This program is a remote control, data output program for spot frequency measurement via the HP-IB.

9825A Program :

```

0: flt 3
1: clr 717
2: wrt 717,"FMT2T2"
3: wrt 717,"FR1EN"
4: wrt 717,"EX"
5: red 717,R,B,C,D,E,F,G
6: dsp C,D,G
7: prt C,D,G
8: end
*1785

```

HP-85 Program :

```

10 CLEAR 717
20 OUTPUT 717 "FMT2T2"
30 OUTPUT 717 "FR1EN"
40 OUTPUT 717 "EX"
50 ENTER 717 ; R,B,C,D,E,F,G
60 DISP C,D,G
70 PRINT C,D,G
80 END

```

Line		Description
9825A	HP 85	
1	10	Sets all 4193A's controls to Initial Control Settings.
2	20	Selects the data output format and the trigger mode. See para. 3-73.
3	30	Sets test frequency to 1MHz.
4	40	Triggers the 4193A.
5	50	Reads the output data from the 4193A.
6	60	Displays the magnitude, phase, and test frequency values on the controller's display.
7	70	Prints out the measurement data on the controller's printer.

To store the complete output data, the following program can be used :

9825A Program :

```

0: dim A$[100]
1: clr 717
2: wrt 717,"FMT4T2"
3: wrt 717,"FR1EN"
4: wrt 717,"EX"
5: red 717,A$
6: prt A$
7: end
*21373

```

HP-85 Program :

```

10 DIM A$[100]
20 CLEAR 717
30 OUTPUT 717 "FMT4T2"
40 OUTPUT 717 "FR1EN"
50 OUTPUT 717 "EX"
60 ENTER 717 ; A$
70 PRINT A$
80 END

```

Figure 3-19. Sample Program 1.

SECTION III

Sample Program 2

PURPOSE :

This program is a remote control, data output program for swept frequency measurement via the HP-IB.

9825A Program :

HP-85 Program :

```

0: flt 3
1: clr 717
2: wrt 717,"FMT2T2"
3: wrt 717,"TF10ENPF2OENW1"
4: wrt 717,"EX"
5: red 717,A,B,C,D,E,F,G
6: prt C,D,G
7: if E=3;jmp 2
8: gto 4
9: end
*5830
10 CLEAR 717
20 OUTPUT 717 "FMT2T2"
30 OUTPUT 717 "TF10ENPF2OENW1"
40 OUTPUT 717 "EX"
50 ENTER 717 ; A,B,C,D,E,F,G
60 PRINT C,D,G
70 IF E=3 THEN 90
80 GOTO 40
90 END
    
```

Line		Description
9825A	HP 85	
1	10	Sets all 4193A's controls to Initial Control Settings.
2	20	Selects the data output format and the trigger mode. See para. 3-73.
3	30	Sets the START frequency and STOP frequency for a PARTIAL sweep to 10MHz and 20MHz, respectively.
4	40	Triggers the 4193A.
5	50	Reads the output data from the 4193A.
6	60	Prints out the magnitude, phase, and test frequency data on the controller's printer.
7	70	When the test frequency reaches the STOP frequency, E changes from 1 to 3. See para. 3-72.

For FULL sweep measurement, the following program can be used :

9825A Program :

HP-85 Program :

```

0: flt 3
1: clr 717
2: wrt 717,"FMT2T2W2"
3: wrt 717,"EX"
4: red 717,A,B,C,D,E,F,G
5: prt C,D,G
6: if E=3;jmp 2
7: gto 3
8: end
*12992
10 CLEAR 717
20 OUTPUT 717 "FMT2T2W2"
30 OUTPUT 717 "EX"
40 ENTER 717 ; A,B,C,D,E,F,G
50 PRINT C,D,G
60 IF E=3 THEN 80
70 GOTO 30
80 END
    
```

Figure 3-20. Sample Program 2.

Table 4-1. Recommended Test Equipment (Sheet 1 of 2)

Equipment	Critical Specifications	Recommended Model	Use*
Probe Type Standards	10 Ω \pm .1 Ω at dc	HP 16345A	P
	50 Ω \pm .5 Ω at dc		P
	100 Ω \pm 1 Ω at dc		P,A,T
	180 Ω \pm 1.8 Ω at dc		P
	1k Ω \pm 10 Ω at dc		P
	1.8k Ω \pm 18 Ω at dc		P
	10k Ω \pm 100 Ω at dc		P
	5pF \pm 1pF Ω at 1MHz		P
Frequency Counter	Frequency Band: 400kHz thru 110MHz Resolution: .1Hz maximum Display: 8 digits Accuracy: \leq 2.5ppm of reading	HP 5382A	P,A,T
	Frequency Band: 300MHz maximum Reactivity: 30mVrms	HP 5340A	A,T
Digital Voltmeter	DC Voltage Range: 10V Resolution: 10mV Display: 4 digits	HP 3465B	P,A,T
RF Voltmeter	Frequency Range: 400kHz to 110MHz AC Voltage Range: 10mVrms Resolution: 0.1mVrms Accuracy: \leq 5%	HP 3406A	P,A,T
Test Oscillator	Frequency Range: Up to 10MHz Output Level: \geq 0dBm	HP 651B	P,A,T
Power Supply	Voltage Range: 0 to 10Volts	HP 6214A	A,T
Pulse Generator	Pulse Width: 10nsec.	8012B	A,T
Oscilloscope	Frequency Range: 5MHz Deflection Factor: 50mV/DIV Dual-channel	HP1740A	A,T
Sampling Scope	Time-base: .5nsec.	HP 180C/1811A	A,T
Sampling Head	Bandwidth: 2GHz	HP 1430C	A,T
Spectrum Analyzer	Frequency Range: 50MHz to 550MHz	HP141T/8552B/8554B	A,T
Calculator		HP 9825A	P
A12 BPF ADJ Board		HP P/N 04193-66564	A,T
20dB Attenuator	Type N (2EA)	HP 8491A	A,T

* USE: P = Performance Test, A = Adjustment, T = Troubleshooting

SECTION IV

Table 4-1. Recommended Test Equipment (Sheet 2 of 2)

Equipment	Critical Specifications	Recommended Model	Use*
Adapters	50 Ω T Adapter	HP 11063A	A
	BNC (female)-GR874 Adapter	HP P/N 1250-0850	A
	BNC Probe Adapter	HP P/N 04193-61152	A
	BNC T Adapter (2EA)	HP P/N 1250-0781	A,T
	BNC(female)-SMB(female)Adapter(4EA)	HP P/N 1250-1236	A,T
	BNC(female)-TYPE N(female) Adapter	HP P/N 1250-1476	A,T
	BNC(female)-TYPE N(male) Adapter(2EA)	HP P/N 1250-1535	A,T
	BNC(female)-BNC(female) Adapter	HP P/N 1250-0080	A,T
Extender Boards	12 pin dual in-line	HP P/N 04193-66561	A,T
	12 pin dual in-line	HP P/N 04193-66562	A,T
	24 pin dual in-line	HP P/N 04193-66563	A,T
Extender Cable	SMB (male)-SMB (female) cable (3EA)	HP P/N 04193-61630	T
Vise Ass'y		HP P/N 04193-69500	T
Termination	GR 874 50 Ω Termination	HP P/N 0950-0090	A
Phase Reference Board		HP P/N 04193-66565	T

* USE: P = Performance Test, A = Adjustment, T = Troubleshooting

SECTION IV

PERFORMANCE TESTS

4-1. INTRODUCTION

4-2. This section provides the tests and procedures used to verify the 4193A specifications listed in Table 1-1. All tests can be performed without access to the interior of the instrument. The performance tests can be used when performing incoming inspection of the instrument and when verifying that the instrument meets specified performance after troubleshooting and/or adjustment. If the performance tests indicate that the instrument is operating outside specified limits, check that the controls on the instruments used in the test and the test setup itself are correct and then proceed with adjustments and/or troubleshooting.

Note

To ensure proper test results and instrument operation, Hewlett-Packard suggests a 60 minute warm-up and stabilization period before performing any of the performance tests.

4-3. EQUIPMENT REQUIRED

4-4. Equipment required to perform all of the performance tests is listed in Table 4-1. Any equipment that satisfies or exceeds the critical specifications listed in the table may be used as a substitute for the recommended models. Accuracy checks described in this section use the HP Model 16345A Probe Type Calibration Box. The characteristics of the equipment satisfy the performance requirements for the accuracy checks and are especially suited for use as the 4193A's accuracy test standards.

Note

Components used as standards should be calibrated by an instrument whose accuracy is traceable to NBS or an equivalent standards group; or calibrated directly by an authorized calibration organization such as NBS. The calibration cycle should be in accordance with the stability specifications of each component.

4-5. TEST RECORD

4-6. Performance test results can be recorded on the Test Record at the completion of the test. The Test Record is at the end of this section and it lists all the tested specifications and their acceptable limits. Test results recorded at incoming inspection can be used for comparison in periodic maintenance, troubleshooting, and after repair or adjustment.

4-7. CALIBRATION CYCLE

4-8. This instrument requires periodic verification of performance. Depending on the conditions under which the instrument is used, e.g., environmental conditions or frequency of use, the instrument should be checked, with the performance tests described here, at least once a year. To keep instrument down-time minimum and to insure optimum operation, preventive maintenance should be performed at least twice a year.

PERFORMANCE TESTS

4-9. INITIAL OPERATION CHECK

PURPOSE : This check verifies that the logic section and display section are functioning properly.



Figure 4-1. Initial Operation Check Setup.

EQUIPMENT :

None.

PROCEDURE :

1. Insert the probe into the PROBE REST as shown in Figure 4-1.
2. Turn the instrument on.

[DISPLAY TEST]

3. Confirm that all front-panel indicator lamps and display segments light for about three seconds.

[SELF TEST]

4. Confirm that the following SELF TEST codes are sequentially displayed on the FREQUENCY display :

---- : Indicates that the SELF TEST program is in progress.

PASS : Indicates that the instrument has passed the SELF TEST.

H-17 : HP-IB address. Seventeen (17) is the factory-set address.

Note : If "**FAIL**" appears on the FREQUENCY display, the instrument needs service. Refer to Section VIII.

[INITIAL CONTROL SETTINGS]

5. Confirm that the instrument is set to the Initial Control Settings listed below.

Panel Controls :	Test Parameters :		
MAGNITUDE RANGE	AUTO	SPOT FREQ	10MHz
HIGH SPEED	OFF	START FREQ4MHz
TRIGGER	INT	STOP FREQ	110MHz
FREQUENCY RESOLUTION	FINE	RECORDER OUTPUTS0V
ENTER	OFF		
STEPS	100		
PARTIAL SWEEP	OFF		
FULL SWEEP	OFF		
SELF TEST	OFF		
X-Y RECORDER ON/OFF	OFF		
INTERPOLATION	OFF		

PERFORMANCE TESTS

4-10. TEST FREQUENCY ACCURACY TEST

PURPOSE: This test verifies that the test frequency is within specifications.

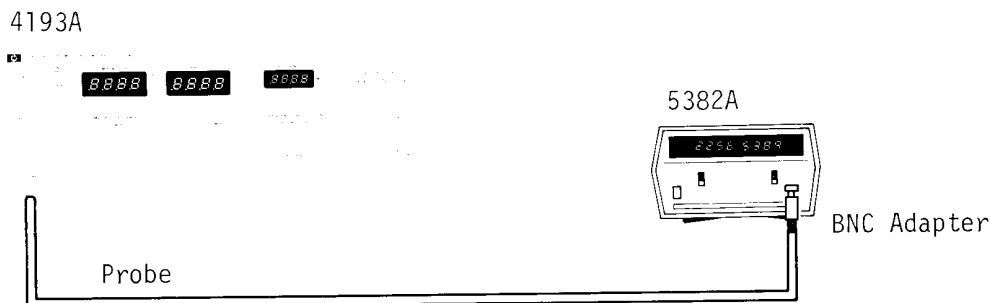

Figure 4-2. Test Frequency Accuracy Test Setup.

EQUIPMENT:

Frequency Counter HP 5382A
 BNC Adapter HP P/N 04193-61152

PROCEDURE:

1. Connect the 4193A's probe to the 5382A's input as shown in Figure 4-2. Use the furnished BNC adapter (HP Part No. : 04193-61152).
2. Set the 4193A and 5382A to the following control settings :
 - 4193A : Test Frequency 41.93MHz
 - Other Controls Initial Settings
 - 5382A : GATE TIME1S
 - ATTENUATOR x10
3. Press the SELF TEST key and confirm that the MAGNITUDE and PHASE displays are as shown below.

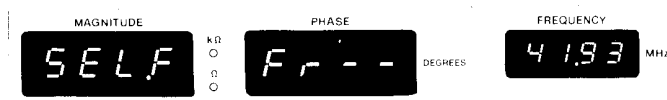

4. Change the test frequency from 41.93MHz to 0.4MHz, and confirm that the 5382A displays .40000MHz \pm 40Hz.
5. Successively change the test frequency to 9.999MHz, 10.00MHz, 39.99MHz, 40.00MHz, 69.99MHz, 70.00MHz, and 110.0MHz, and confirm that the frequency readings on the 5382A are within the test limits listed in Table 4-2.

Table 4-2. Test Frequency Accuracy Test Limits

Test Frequency (MHz)	Table Limits (MHz)
0.400	0.399960 to 0.400040
9.999	9.99800 to 9.99999
10.00	9.99900 to 10.0010
39.99	39.9860 to 39.9939
40.00	39.9960 to 40.0040
69.99	69.9830 to 69.9969
70.00	69.9930 to 70.0070
110.0	109.989 to 110.011

PERFORMANCE TESTS

PERFORMANCE TESTS

4-12. IMPEDANCE ACCURACY TEST

PURPOSE: This test verifies that the accuracy of impedance measurements is within specifications.

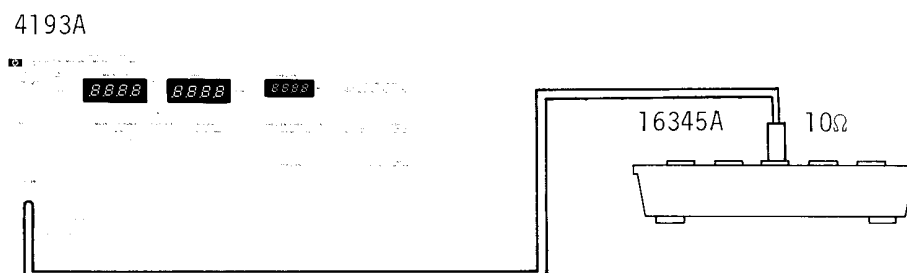

Figure 4-4. Impedance Accuracy Test Setup.

EQUIPMENT:

Probe Type Cal. Box HP 16345A

PROCEDURE:

1. Turn on the instrument to establish Initial Control Settings.
2. Connect the probe to the 10Ω standard of the 16345A.
3. Read measured values displayed on the MAGNITUDE and PHASE displays when test frequency is set to 0.4MHz, 1MHz, 10MHz, 40MHz, and 110MHz, respectively.
4. Confirm that each value is within the test limits listed in Table 4-4.
5. Perform step 3 for each of the 100Ω, 1kΩ, 10kΩ, and 5pF standards, and confirm that each value is within the test limits listed in Tables 4-5 through 4-8.

Table 4-4. Impedance Accuracy Test Limits for 10Ω

Test Frequency	Test Limits	
	Magnitude	Phase
0.4MHz	C.V.* ±84 counts	C.V.* ±62 counts
1MHz	C.V. ±72 counts	C.V. ±35 counts
10MHz	C.V. ±72 counts	C.V. ±53 counts
40MHz	C.V. ±133 counts	C.V. ±113 counts
110MHz	C.V. ±329 counts	C.V. ±253 counts

*: Reference value listed in the data sheet of the 16345A

PERFORMANCE TESTS

Table 4-5. Impedance Accuracy Test Limits for 100 Ω

Test Frequency	Test Limits	
	Magnitude	Phase
0.4MHz	C.V.* ± 42 counts	C.V.* ± 62 counts
1MHz	C.V. ± 34 counts	C.V. ± 34 counts
10MHz	C.V. ± 34 counts	C.V. ± 36 counts
40MHz	C.V. ± 44 counts	C.V. ± 47 counts
110MHz	C.V. ± 71 counts	C.V. ± 71 counts

Table 4-6. Impedance Accuracy Test Limits for 1k Ω

Test Frequency	Test Limits	
	Magnitude	Phase
0.4MHz	C.V.* ± 50 counts	C.V.* ± 61 counts
1MHz	C.V. ± 41 counts	C.V. ± 34 counts
10MHz	C.V. ± 41 counts	C.V. ± 44 counts
40MHz	C.V. ± 72 counts	C.V. ± 77 counts
110MHz	C.V. ± 122 counts	C.V. ± 154 counts

Table 4-7. Impedance Accuracy Test Limits for 10k Ω

Test Frequency	Test Limits	
	Magnitude	Phase
0.4MHz	C.V.* ± 47 counts	C.V.* ± 65 counts
1MHz	C.V. ± 38 counts	C.V. ± 36 counts
10MHz	C.V. ± 46 counts	C.V. ± 84 counts
40MHz	C.V. ± 77 counts	C.V. ± 87 counts

Table 4-8. Impedance Accuracy Test Limits for 5pF

Test Frequency	Test Limits	
	Magnitude	Phase
0.4MHz	C.V.* ± 7 counts	C.V.* ± 8 counts
1MHz	C.V. ± 5 counts	C.V. ± 6 counts

* : Reference value listed in the data sheet of the l6345A

PERFORMANCE TESTS

4-13. EXTERNAL OSCILLATOR USAGE CHECK

PURPOSE: This test verifies the useability of an external signal source.

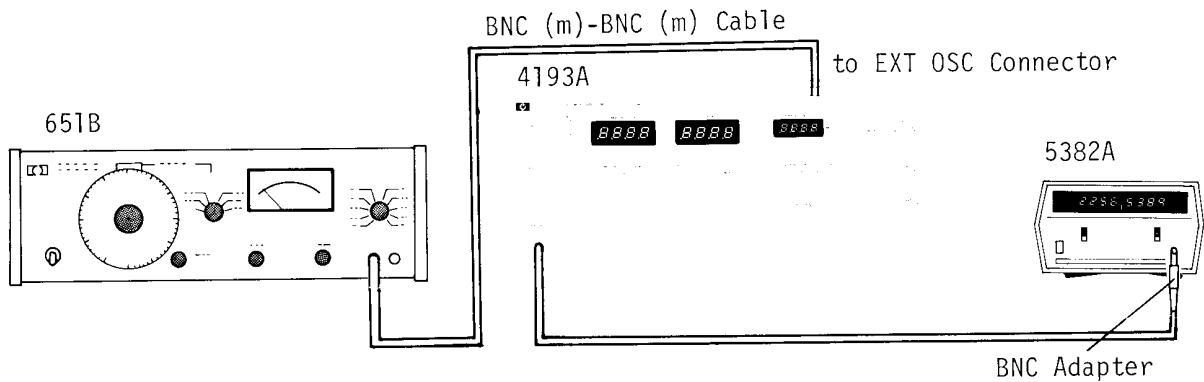

Figure 4-5. External Oscillator Usage Check Setup.

EQUIPMENT:

Test Oscillator	HP 651B
Frequency Counter	HP 5382A
BNC Adapter	HP P/N 04193-61152

PROCEDURE:

1. Connect the probe to the 5382A's input with the furnished BNC adapter (HP Part No. : 04193-61152), and connect the 651B 50Ω output to the 4193A's EXT OSC terminal on the rear-panel as shown in Figure 4-5.
2. Set the instruments' controls as follows :

4193A :	Test Frequency	41.93MHz
	Other Controls	Initial Settings
651B :	FREQUENCY	10MHz
	OUTPUT ATTENUATOR	-70dBm
	OUTPUT AMPLITUDE	0dBm
5382A :	GATE TIME1S
	ATTENUATOR	x10
3. Press the 4193A's SELF TEST key and confirm that the MAGNITUDE and PHASE displays are as shown below :

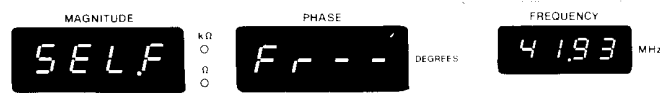

4. Set the 4193A's test frequency to 10.00MHz.
5. Confirm that the 5382A displays 10.000MHz ±1kHz.
6. Set the 651B's OUTPUT ATTENUATOR switch to 0dBm.
7. Confirm that the 4193A's EXT OSC lamp on the front-panel turns on, and that the 5382A displays the 651B's test frequency, approximately 10MHz.

PERFORMANCE TESTS

4-14. RECORDER OUTPUT VOLTAGE ACCURACY TEST

PURPOSE: This test verifies that the RECORDER OUTPUT voltages are within specifications.

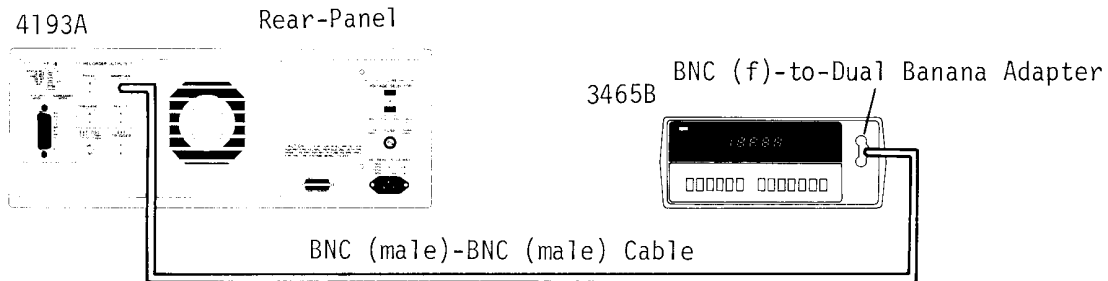

Figure 4-6. Recorder-output Voltage Accuracy Test Setup.

EQUIPMENT:

- DVM HP 3465B
- BNC (female)-Dual Banana Adapter HP P/N 1251-2277

PROCEDURE:

1. Connect the INPUT of the 3465B to the MAGNITUDE RECORDER OUTPUT terminal on the rear-panel of the 4193A. Refer to Figure 4-6.
2. Set the instruments' controls as follows.
 - 3465B: FUNCTION $\overline{=}$ V
 - RANGE 2
 - 4193A: Initial Settings
3. Press the ^{LL} key on the 4193A. The readout on the 3465B should be $0V \pm 20mV$.
4. Press the ^{UR} key on the 4193A. The readout on the 3465B should be $1V \pm 30mV$.
5. Repeat steps 3 and 4 for the PHASE and FREQUENCY RECORDER OUTPUTS.

Table 4-9. Recorder-output Voltage Limits

	Minimum	Actual Value	Maximum
MAGNITUDE output:			
Lower Left (LL):	- 20mV	V _{LL} : _____	+ 20mV
Upper Right (UR):	+ 970mV	_____	+ 1030mV
PHASE output:			
Lower Left (LL):	- 20mV	V _{LL} : _____	+ 20mV
Upper Right (UR):	+ 970mV	_____	+ 1030mV
FREQUENCY output:			
Lower Left (LL):	-20mV	V _{LL} : _____	+ 20mV
Upper Right (UR):	+ 970mV	_____	+ 1030mV

Skip

PERFORMANCE TESTS

4-15. HP-IB INTERFACE TEST

PURPOSE : This test verifies the instrument's HP-IB capabilities.

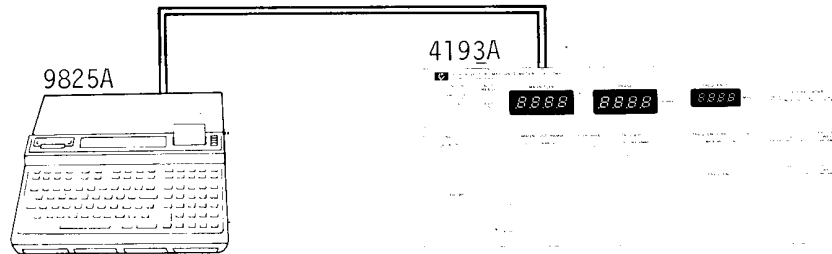

Figure 4-7. HP-IB Interface Test Setup.

EQUIPMENT :

Calculator	HP9825A (9825B)
I/O ROM's	HP98210A, 98213A
Interface Cable	HP98034A (98034B)
100Ω Standard	HP16345A

PROCEDURE :

- a. Turn both the 4193A and the 9825A off.
- b. Connect the 98034A between the 9825A and 4193A as shown in Figure 4-7, and install the I/O ROM's in the ROM slots.
- c. Set the 4193A's HP-IB control switch, located on the rear panel, as follows :
 - bits 1 - 5 : 10001 (17₁₀)
 - bit 6 : 0
 - bit 7 : 0
- d. Turn the 4193A and the 9825A on.
- e. Load one of the three test programs into the calculator. Test programs are listed on pages 4-10, 4-12, and 4-14.
- f. Execute the program and follow the prompts and instructions that are output by the 9825A. Details on the controller's (calculator) instructions and the appropriate operator response are given in Tables 4-10 through 4-12.

PERFORMANCE TESTS

TEST PROGRAM 1

PURPOSE :

This test verifies that the 4193A has the following HP-IB capabilities :

- (1) Remote/Local Capability
- (2) Local Lockout
- (3) Talk Disable
- (4) Listen Disable

PROGRAM LISTING:

```

0: "REMOTE/LOCAL TEST":
1: dim A$(1)
2: O>N
3: rds(717)>S
4: prt "REMOTE/LOCAL TEST";spc 3
5: rem ?
6: wrt 717,"T1";ent "LISTEN=1,TALK=0,REMOTE=1",A$
7: if A$="n";1>N
8: cli ?;ent "LISTEN=0,TALK=0,REMOTE=1",A$
9: if A$="n";1>N
10: lcl ?;ent "LISTEN=0,TALK=0,REMOTE=0",A$
11: if A$="n";1>N
12: rem 717;ent "LISTEN=1,TALK=0,REMOTE=1",A$
13: if A$="n";1>N
14: llo ?
15: lcl 717;ent "LISTEN=1,TALK=0,REMOTE=0",A$
16: if A$="n";1>N
17: rem 717;wrt 717,"T1";ent "LISTEN=1,TALK=0,REMOTE=1",A$
18: if A$="n";1>N
19: if N=1;prt "REMOTE/LOCAL TEST FAIL";spc 3;jmp 2
20: prt "REMOTE/LOCAL TEST PASS";spc 3
21: O>N
22: prt "LISTEN/TALK TEST";spc 3
23: red 717,A;ent "LISTEN=0,TALK=1,REMOTE=1",A$
24: if A$="n";1>N
25: wrt 717,"T1";ent "LISTEN=1,TALK=0,REMOTE=1",A$
26: if A$="n";1>N
27: if N=1;prt "LISTEN/TALK TEST FAIL";spc 3;jmp 2
28: prt "LISTEN/TALK TEST PASS";spc 3
29: prt "END";spc 3
30: cli ?
31: lcl ?
32: end
*14058

```

PERFORMANCE TESTS

Table 4-10. Controller Instructions and Operator Responses for Test Program 1

Controller Instructions		Operator Response
Status Indicators	Printout	
	REMOTE/LOCAL TEST	
LISTEN = 1*, TALK = 0, REMOTE = 1		If the 4193A HP-IB Status Indicators and Controller Display are the same, press <input type="radio"/> Y , and <input type="button" value="CONTINUE"/> . If not, press <input type="radio"/> N and <input type="button" value="CONTINUE"/> .
LISTEN = 0, TALK = 0, REMOTE = 1		
LISTEN = 0, TALK = 0, REMOTE = 0		
LISTEN = 1, TALK = 0, REMOTE = 1		
LISTEN = 1, TALK = 0, REMOTE = 0		
LISTEN = 1, TALK = 0, REMOTE = 1		
	REMOTE/LOCAL TEST PASS	If all steps are correct, this message is output.
	REMOTE/TALK TEST FAIL	If any step fails, this message is output.
	LISTEN/TALK TEST	
LISTEN = 0, TALK = 1, REMOTE = 1		If the 4193A HP-IB Status Indicators and Controller Display are the same, press <input type="radio"/> Y , and <input type="button" value="CONTINUE"/> . If not, press <input type="radio"/> N and <input type="button" value="CONTINUE"/> .
LISTEN = 1, TALK = 0, REMOTE = 1		
	LISTEN/TALK TEST PASS	If both steps are correct, this message is output.
	LISTEN/TALK TEST FAIL	If any step fails, this message is output.
	END	

*1 indicates ON; 0 indicates OFF.

PERFORMANCE TESTS

TEST PROGRAM 2

PURPOSE :

This test verifies that the 4193A has the following HP-IB capabilities :

- (1) Talker
- (2) Device Trigger

PROGRAMMING :

```

0: "TALKER TEST":
1: prt "TALKER TEST";spc 3
2: dsp "Insert probe to 100ohm";stp
3: prt "DATA OUTPUT TEST";spc 3
4: dim A$(100),B$(1)
5: rds(717)>S
6: rem ?
7: cli ?
8: clr 717
9: wrt 717,"H1T2FMT2"
10: ent "Test frequency in MHz?",F
11: wrt 717,"FR",F,"EN"
12: trg 717
13: red 717,A,B,C,D,E,F,G
14: prt C,D,G;spc 2
15: ent "Is output data correct?(y or n)",B$
16: if B$="n";prt "DATA OUTPUT TEST FAIL";spc 3;jmp 2
17: prt "DATA OUTPUT TEST PASS";spc 3
18: prt "COMPLETE DATA OUTPUT TEST";spc 2
19: wrt 717,"H1T2FMT4"
20: trg 717
21: red 717,A$
22: prt A$;spc 2
23: ent "Is output data correct?(y or n)",B$
24: if B$="n";prt "COMPLETE DATA OUTPUT TEST FAIL";spc 3;jmp 2
25: prt "COMPLETE DATA OUTPUT TEST PASS";spc 3
26: end
*5970

```

PERFORMANCE TESTS

Table 4-11. Controller Instructions and Operator Responses for Test Program 2

Controller Instructions		Operator Response
Displays	Printout	
	TALKER TEST	
Insert probe to 100ohm.		Insert the probe to 100Ω standard in the 16345A. Then press <input type="button" value="CONTINUE"/> .
Test Frequency in MHz?	DATA OUTPUT TEST	Type the desired test frequency value, from 0.4 to 110, and press <input type="button" value="CONTINUE"/> .
Is output data correct? (y or n)	[Magnitude] [Phase] [Test Frequency]	If the output data is the same as the values displayed on each 4193A display, press <input type="button" value="Y"/> and <input type="button" value="CONTINUE"/> . If not, press <input type="button" value="N"/> and <input type="button" value="CONTINUE"/> .
	DATA OUTPUT TEST PASS	DATA OUTPUT TEST result.
	DATA OUTPUT TEST FAIL	
	COMPLETE DATA OUTPUT TEST	
Is output data correct? (y or n)	Y1, S2, ZM [Magnitude], ZP [Phase], W4, B0, FR [Test Frequency], P1, Q3, A1, R2, H1, T2, X0, I0, G1, D0	If the output data is the same as the left values, press <input type="button" value="Y"/> and <input type="button" value="CONTINUE"/> . If not, press <input type="button" value="N"/> and <input type="button" value="CONTINUE"/> .
	COMPLETE DATA OUTPUT TEST PASS	COMPLETE DATA OUTPUT TEST result.
	COMPLETE DATA OUTPUT TEST FAIL	

PERFORMANCE TESTS

TEST PROGRAM 3

PURPOSE:

This test program verifies that the 4193A has the following HP-IB capabilities:

- (1) Service Request
- (2) Serial Poll

PROGRAM LISTING:

```

0: "SRQ TEST":
1: prt "SRQ TEST";spc 3
2: fxd 0
3: oni 7,"SRQ"
4: rem 7
5: cli 7
6: clr 717
7: wrt 717,"GO"
8: 0>S;prt "DATA READY";wrt 717,"D1T2";trg 717;gsb "LOOP"
9: 0>S;prt "SYNTAX ERROR";wrt 717,"D0W4CL";gsb "LOOP"
10: 0>S;prt "SELF TEST END";wrt 717,"S1";dsp "SELF TEST in progress"
11: gsb "LOOP"
12: 0>S;prt "TRG. TOO FAST";dsp "Connect EXT TRG pin to ground";gsb "LOOP1"
13: gsb "LOOP"
14: 0>S;prt "INEFFECTIVE PROGRAM";wrt 717,"W1S1CL";gsb "LOOP"
15: prt "SRQ TEST END";spc 2
16: clr 717
17: cli 7
18: lcl 7
19: end
20: "LOOP":eir 7,128
21: if S>0;prt S;spc 1;ret
22: gto "LOOP"
23: "SRQ":nds(717)>S
24: if bit(6,S)=1;jmp 2
25: prt "OTHER DEVICE SRQ";spc 3
26: "IRET":eir 7,128
27: iret
28: "LOOP1":wrt 717,"FMT1G1CL"
29: trg 717
30: red 717,A,B,C,D
31: if S=0;gto "LOOP1"
32: wrt 717,"GO"
33: ret
*19486

```

PERFORMANCE TESTS

Table 4-12. Controller Instructions and Operator Responses for Test Program 3

Controller Instructions		Operator Response
Displays	Printout	
	SRQ TEST	
	DATA READY 65	SRQ Status Byte data should be 65 (= 01000001).
	SYNTAX ERROR 66	SRQ Status Byte data should be 66 (= 01000010).
SELF TEST in progress	SELF TEST END 84	SRQ Status Byte data should be 84 (= 01010100). If the instrument fails SELF TEST, it should be 68 (= 01000100).
Connect EXT TRG pin to ground	TRG. TOO FAST 72	Connect the EXT TRG pin on the rear-panel to ground. SRQ Status Byte data should be 72 (= 01001000).
	INEFFECTIVE PROGRAM 96	SRQ Status Byte data should be 96 (= 01100000).
	SRQ TEST END	

SECTION V

Table 5-1. Adjustable Components

Reference Designation	Name of Control	Purpose
A1C3 (Para. 5-28)	Vp ADJ	Equalizes the height of the V-Channel and I-Channel sampling pulses in order to maximize sampling efficiency in both channels.
A2R58 (Para. 5-27)	BIAS ADJ	Eliminates test signal harmonics in order to minimize measurement error.
A3R9 (Para. 5-33)	VB	Adjusts the dc bias voltage applied to sampling diodes.
A3R6 (Para. 5-34)	MAG ADJ	Adjusts the V channel gain in order to adjust the amplitude of the magnitude signal.
A4R10 (Para. 5-31)	IB	Adjusts the dc bias voltage applied to sampling diodes.
A4R30 (Para. 5-32)	GAIN	Adjusts the I channel gain in order to adjust the current level through the DUT.
A4R6 (Para. 5-34)	PHASE ADJ	Eliminates the phase shift in the medium frequency range.
A6C8 (Para. 5-25)	VCXO ADJ	Adjusts the VCXO frequency range.
A6C7 (Para. 5-26)	BPF ADJ	Adjusts the center frequency of the BPF to 299.99MHz.
A8C28 (Para. 5-21)	100MHz ADJ	Adjusts the reference frequency of the Crystal Oscillator to 100MHz.
A8C3 (Para. 5-22)	BPF ADJ	Adjusts the center frequency of the BPF to 300MHz.
A8R1 (Para. 5-23)	LEVEL ADJ	Controls the output signal level to the MIXER on the A9 board.
A11R5 (Para. 5-24)	OFFSET	Eliminate any dc offset voltage in the Integrator Circuit on the A11 board in order to maximize measurement accuracy.
A12R11 (Para. 5-30)	GAIN I	Adjusts the gain of the IF BPF in the I channel.
A12R12 (Para. 5-30)	PHASE I	Adjusts the center frequency of the IF BPF in the I channel.
A12R3 (Para. 5-30)	GAIN V/I	Adjusts the gain of the IF BPF in the V/I channel.
A12R4 (Para. 5-30)	PHASE V/I	Adjusts the center frequency of the IF BPF in V/I channel.
A13R1 (Para. 5-29)	ALC BIAS	Adjusts ALC reference voltage in the Integrator Circuit.
A15R1 (Para. 5-35)	F FS ADJ	Adjusts the full-scale output voltage for frequency analog output.
A15R2 (Para. 5-35)	M FS ADJ	Adjusts the full-scale output voltage for magnitude analog output.
A15R3 (Para. 5-35)	P FS ADJ	Adjusts the full-scale output voltage for phase analog output.
A41 (Para. 5-54)	LENGTH ADJ	Eliminate the phase difference between V and I channels in the high frequency range.

SECTION V ADJUSTMENT

5-1. INTRODUCTION

5-2. This section describes the adjustments and checks required to return the 4193A to the specifications listed in Table 1-1 after repairs have been made. These adjustments and checks can also be performed along with periodic maintenance to keep the instrument in optimum operating condition. The recommended adjustment cycle for the 4193A is twice a year. All adjustable components referred to in the adjustment procedures are listed in Table 5-1. If proper performance cannot be achieved after adjustment, refer to the troubleshooting procedures described in Section VIII.

Note

To ensure proper results and instrument operation, Hewlett-Packard suggests a 60 minute warm-up and stabilization period before performing any of the adjustments described here.

5-3. SAFETY REQUIREMENTS

5-4. Although the 4193A was designed in accordance with international safety standards, this manual contains information, cautions, and warnings which must be followed to ensure operator safety and to keep the instrument in a safe and serviceable condition. Adjustments described in this section should be performed by qualified service personnel only.

WARNING

ANY INTERRUPTION OF THE PROTECTIVE (GROUNDED) CONDUCTOR (INSIDE OR OUTSIDE THE INSTRUMENT) OR DISCONNECTION OF THE PROTECTIVE EARTH TERMINAL IS LIKELY TO MAKE THE INSTRUMENT DANGEROUS. INTENTIONAL INTERRUPTION, FOR ANY REASON, IS PROHIBITED.

5-5. The removal or opening of covers for removal or adjustment of parts, other than those which are accessible by hand, will expose live parts.

5-6. Capacitors in the instrument may still be charged even if the instrument has been disconnected from the power source (AC line) for an extended period of time.

WARNING

ADJUSTMENTS DESCRIBED IN THIS SECTION ARE PERFORMED WITH POWER SUPPLIED AND PROTECTIVE COVERS REMOVED. ENERGY EXISTING AT MANY POINTS MAY, IF CONTACTED, RESULT IN SERIOUS PERSONAL INJURY.

5-7. EQUIPMENT REQUIRED

5-8. All the equipment required to perform the adjustments described in this section are listed in Table 4-1 on page 4-0. Each piece of equipment listed in Table 4-1 should be calibrated to satisfy its own specifications, as well as those of the required characteristics. If the recommended model is not available, any instrument whose specifications equal or surpass those of the recommended model may be used instead.

5-9. FACTORY SELECTED COMPONENTS

5-10. Factory selected components are identifiable by an asterisk (*) adjacent to the reference designator on the schematic diagrams in Section VIII (only nominal values are given). Table 5-2 lists the reference designators of all factory selected components. Also listed in Table 5-2 are the nominal value range of each component and a brief description of how each component affects instrument performance.

Adjustable components, with reference designators, are listed in Table 5-1. This table also lists the name of the adjustment and its purpose.

SECTION V

5-11. ADJUSTMENT RELATIONSHIPS

5-12. The adjustment procedures described in this section, beginning with paragraph 5-21, are interactive and therefore should be performed in the sequence given. Ignoring or changing the order of the procedures may make it impossible to obtain optimum instrument performance. Table 5-3 lists the necessary adjustment procedures to follow after the instrument has been repaired.

5-13. ADJUSTMENT LOCATIONS

5-14. To help locate the appropriate adjustment points, the locations of the components to be adjusted are illustrated throughout the adjustment procedures. The locations of factory selected components, connectors, and other components related to the adjustments are shown in the individual board assembly-component illustrations (fold-out service sheets) in Section VIII.

5-15. INITIAL OPERATING PROCEDURE

5-16. Before proceeding with the adjustments described starting in paragraph 5-21, perform the following three preliminary procedures. These procedures provide access to the various adjustment points and facilitate a thoroughgoing adjustment. Initial Control Settings, described in paragraph 3-9, must be used for each adjustment. Exceptions to these settings will be noted as they occur. After completing an adjustment, return the 4193A's controls to the initial control settings.

[BASIC OPERATING CHECK]

Check that the instrument's line voltage selector switches, located on the rear panel, are set to the positions appropriate for the local line voltage. This should be performed before proceeding with any of the adjustments.

After the recommended 60 minute warm-up period, the instrument should pass the SELF TEST (no error message should appear), and the initial control settings listed in paragraph 3-9 should be automatically set in preparation for measurements. If the instrument displays an error message or does not have the correct initial control settings, refer to the troubleshooting procedures given in Section VIII.

[TOP COVER REMOVAL]

- a. Fully loosen the top-cover retaining screw located at the rear of the top cover.
- b. Slide the top cover towards the rear and lift off.

WARNING

DC VOLTAGES, $\pm 15V$ AND $\pm 5V$, ARE PRESENT AT EXPOSED TERMINALS ON THE EXTRUSION BOARDS. DO NOT TOUCH THESE TERMINALS. AS A SAFETY PRECAUTION AGAINST POSSIBLE ELECTRICAL SHOCK HAZARDS AND RESULTANT INJURY, USE INSULATED TOOLS FOR ALL ADJUSTMENTS.

5-17. EXTRUSION BOARD REMOVAL

5-18. To prepare for a thoroughgoing adjustment, remove all screws securing the A1, A2, A3, A4, A6, and A8 extrusion boards. These boards will require removal at least once during adjustment.

5-19. BOARD EXTENSION

5-20. The extrusion boards are interconnected with SMB (female)-to-SMB (female) cables of various lengths, some of which are not long enough for connection to an extended board. When this situation occurs during adjustment or troubleshooting, use an extension cable, HP P/N: 04193-61630.

Note

The yellow cable between A1P2 and A4P2 has a precise electrical length matching that of the probe cable. DO NOT use a blue cable to connect A1P2 and A4P2.

Table 5-2. Factory Selected Components

Component	Nominal Value Range	Effect on Performance
A8C29	2.4pF (HP P/N: 0160-2242) • 2.7pF (HP P/N: 0160-2243) 3.0pF (HP P/N: 0160-2244)	Sets the Crystal Oscillator frequency close to 100MHz.
A1P2-A4P2 Cable	10cm (HP P/N: 04193-61615, red) • 15cm (HP P/N: 04193-61616, yellow) 20cm (HP P/N: 04193-61617, blue)	Minimizes phase shift error at high frequencies caused by the cable length difference between V and I channels.
A10C69	3.9pF (HP P/N: 0160-4518) • 4.7pF (HP P/N: 0160-3873) 5.6pF (HP P/N: 0160-4498)	Sets the VCO frequency range.
A11R1	min: 0 Ω • 9.09k (HP P/N: 0757-0288) max: 17.8k Ω	Narrows the INTEGRATOR offset adjustable range to facilitate the offset adjustment.
A11R2	min: 0 Ω • 9.09k Ω (HP P/N: 0757-0288) max: 17.8k Ω	

• : typical value

Table 5-3. Adjustment Requirements

Assembly Repaired or Replaced	Required Adjustments
A1 Sampling Pulse Generator (SPG) (P/N 04193-66501)	para. 5-28 thru 5-35.
A2 Automatic Level Control Amplifier (ALC AMP) (P/N 04193-66502)	para. 5-27 thru 5-35.
A3 V Channel Amplifier (V CHAN AMP) (P/N 04193-66503)	para. 5-33 thru 5-35.
A4 I Channel Amplifier (I CHAN AMP) (P/N 04193-66504)	para. 5-31 thru 5-35.
A5 Mixer and Divider (MXR & DIVR) (P/N 04193-66505)	para. 5-28 thru 5-35.
A6 Voltage Controlled Crystal Oscillator (VCXO) (P/N 04193-66506)	para. 5-25 thru 5-35.
A7 Divider (DIVIDER) (P/N 04193-66507)	None.
A8 Crystal Oscillator (XTAL OSC) (P/N 04193-66508)	para. 5-21 thru 5-35.
A9 Mixer (MIXER) (P/N 04193-66509)	None.
A10 Voltage Controlled Oscillator (VCO) (P/N 04193-66510)	None.
A11 Integrator (P/N 04193-66511)	para. 5-24 thru 5-35.
A12 IF BPF (P/N 04193-66512)	para. 5-30 thru 5-35.
A13 Detector (P/N 04193-66513)	para. 5-29 thru 5-35.
A14 Analog-to-Digital Converter (P/N 04193-66514)	None.
A15 Analog Output (P/N 04193-66515)	para. 5-35 only.
A16 HP-IB (P/N 04193-66516)	None.
A17 Control Logic (P/N 04193-66517)	None.
A18 Display (P/N 04193-66518)	None.
A20 POWER SUPPLY (P/N 04193-66520)	para. 5-21 thru 5-35.
A41 Delay (P/N 04193-66541)	para. 5-28 and 5-35.
A51 Probe I Channel (P/N 04193-66551)	para. 5-31 thru 5-35.
A52 Probe V Channel (P/N 04193-66552)	para. 5-33 thru 5-35.

ADJUSTMENTS

5-21. 100MHz REFERENCE FREQUENCY ADJUSTMENT (A8)

PURPOSE: This adjustment sets the frequency of the 100MHz Crystal Oscillator to an accurate 100MHz.

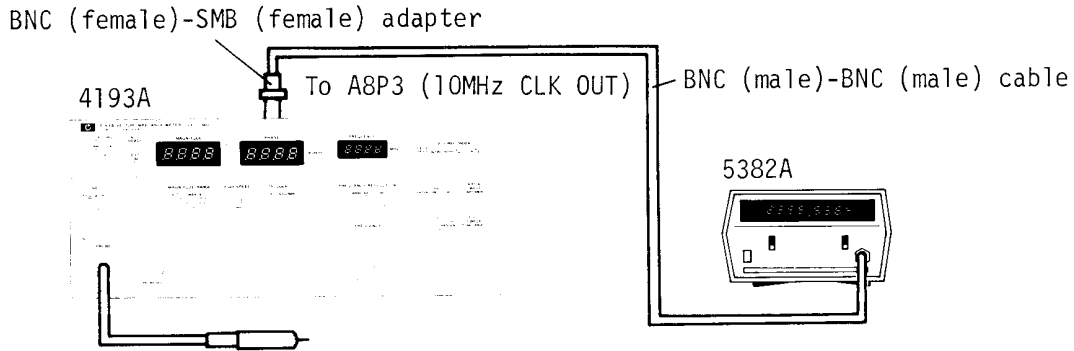

Figure 5-1. 100MHz Reference Frequency Adjustment Setup.

EQUIPMENT:

Frequency Counter HP5382A
 BNC (female)-SMB (female) Adapter HPP/N 1250-1236

PROCEDURE:

1. Disconnect the cable from A8P3 (10MHz CLK OUT).
2. Connect the INPUT terminal of the 5382A to A8P3 (10MHz CLK OUT) as shown in Figure 5-1.
3. Set the 5382A's controls as follows :
 - GATE TIME1S
 - ATTENUATOR xl0
4. Adjust A8C28 (100MHz ADJ) until the reading on the 5382A is 10MHz±10Hz.
5. Reconnect the cable that was disconnected in step 1, and turn the 4193A off and on to return to normal operation.

5-22. 300MHz BPF ADJUSTMENT (A8)

PURPOSE: This adjustment maximizes the level of the 300MHz signal output from the 300MHz BPF on the A8 board by setting the center frequency of the 300MHz BPF to 300MHz.

ADJUSTMENTS

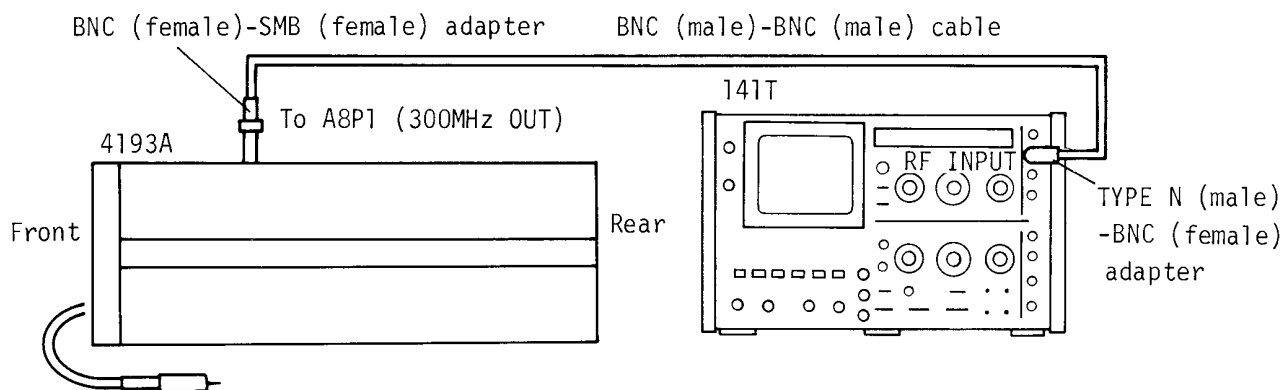

Figure 5-2. 300MHz BPF Adjustment Setup.

EQUIPMENT :

Spectrum Analyzer HP 141T with 8552B and 8554B Plug-ins.
 Type N (male)-BNC (female) Adapter HP P/N 1250-1476
 BNC (female)-SMB (female) Adapter HP P/N 1250-1236
 BNC(male)-BNC(male) Cable HP 11170C

PROCEDURE :

1. Disconnect the cable from A8P1 (300MHz OUT).
2. Connect the RF INPUT terminal of the spectrum analyzer to A8P1 (300MHz OUT) as shown in Figure 5-2.
3. Set the spectrum analyzer's controls as follows :

141T:	PERSISTANCE	NORMAL
	WRITING RATE	NORMAL
8554B:	CENTER FREQUENCY	300MHz
	BANDWIDTH	300kHz
	SCAN WIDTH	50MHz, PER DIVISION
	INPUT ATTENUATION	20dB
8552B:	SCAN TIME	5ms
	LOG REF LEVEL	0dBm
	LOG REF LEVEL SWITCH	10dB LOG
	LINEAR SENSITIVITY	0
	VIDEO FILTER	OFF
	SCAN MODE	INT
	SCAN TRIGGER	AUTO
4. Adjust A8C3 (BPF ADJ) until the level of the 300MHz spectral display on the 141T CRT is maximum. Refer to Figure 5-3.

Note

Leave all connections and control settings as they are, and proceed to paragraph 5-23.

ADJUSTMENTS

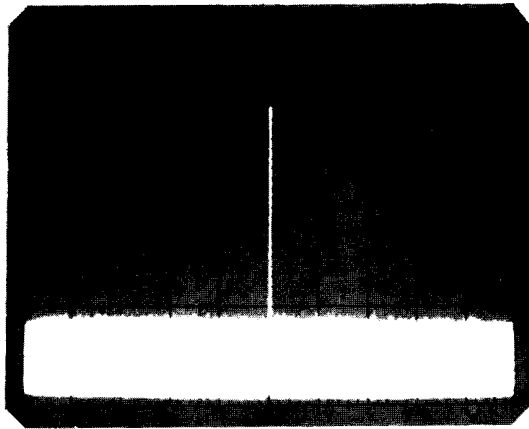

Figure 5-3. 300MHz Level.

ADJUSTMENTS

5-23. 300MHz OUTPUT LEVEL ADJUSTMENT (A8)

PURPOSE: This adjustment sets the level of the 300MHz signal (output from the A8 BPF) supplied to the mixer on the A9 board.

Note

The adjustment described in paragraph 5-22 must be performed before this adjustment.

PROCEDURE:

1. Use the same connections and control settings as those used in paragraph 5-22.
2. Adjust A8R1 (LEVEL ADJ) until the level of the 300MHz spectral display on the 141T CRT is -22dBm. Refer to Figure 5-4.

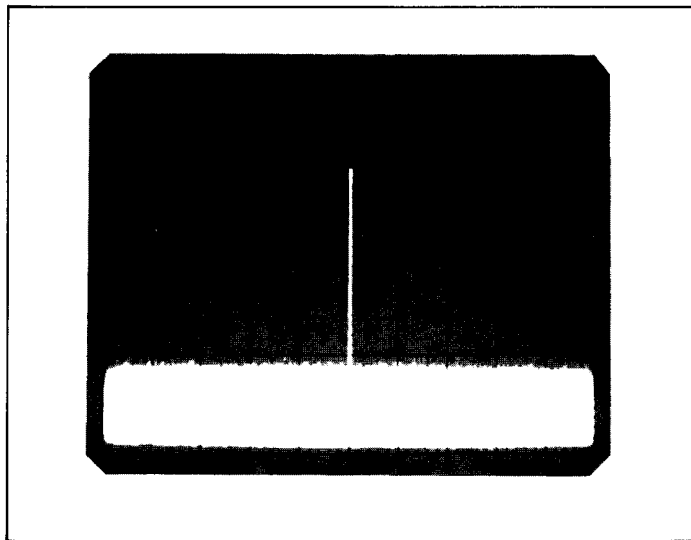

Figure 5-4. 300MHz Level.

ADJUSTMENTS

5-24. INTEGRATOR OFFSET ADJUSTMENT (A11)

PURPOSE: This adjustment provides appropriate offset compensation for the integrator on the All board.

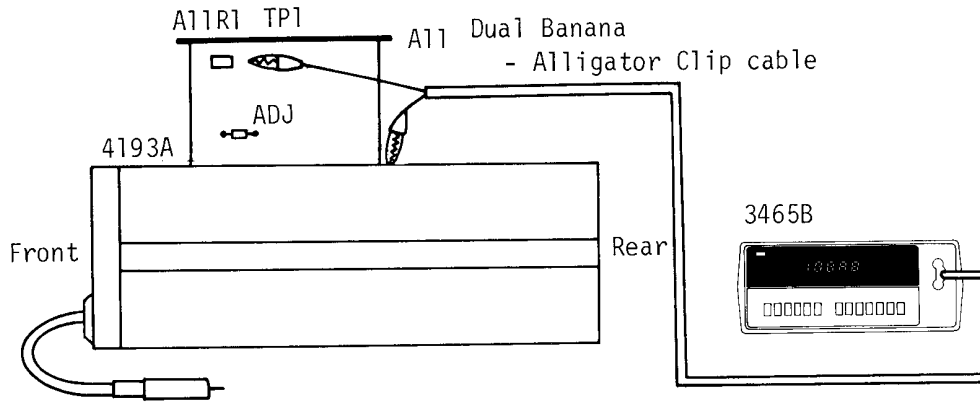

Figure 5-5. Integrator Offset Adjustment Setup.

EQUIPMENT:

Digital Voltmeter HP 3465B
 Extender Board HP P/N 04193-66561
 Dual Banana Plug to Alligator Clip Cable HP 11002A

PROCEDURE:

1. Turn off the 4193A.
2. Extend the All board with an extender board.
3. Turn on the 4193A.
4. Move the jumpers A11J1 and J2 from OPE to ADJ.
5. Connect the INPUT terminal of the 3465B to A11TP1 and chassis, as shown in Figure 5-5.
6. Set the 3465B's controls as follows:

3465B:	FUNCTION	DC V
	RANGE	200mV
7. Adjust A11R3 (OFFSET) until the reading on the 3465B is $-2\text{mV} \pm 0.2\text{mV}$.

Note

If correct adjustment cannot be obtained in step 7, A11R1 and A11R2 must be changed. Measure the voltage at A11TP1 with A11R3 (OFFSET) set fully CCW and then fully CW. The reading on the 3465B at each setting should be lower than (more negative) 0mV and higher than (more positive) -3mV, respectively. If either reading is incorrect, replace A11R1 and A11R2 as described in Table A and Table B. Then repeat step 7.

8. Replace A11J1 and A11J2 to their normal positions, OPE.

ADJUSTMENTS

Table A

Reading on the 3465B When A11R3 is Fully CCW	A11R1		A11R2	
	Resistance	HP Part No.	Resistance	HP Part No.
0mV to -5mV	10.0k Ω	0757-0442	7.50k Ω	0757-0440
-5mV to -15mV	11.0k Ω	0757-0443	6.81k Ω	0757-0439
-15mV to -25mV	12.1k Ω	0757-0444	5.62k Ω	0757-0200
-25mV to -35mV	13.3k Ω	0757-0289	4.64k Ω	0698-3155
-35mV to -45mV	14.7k Ω	0698-3156	3.83k Ω	0698-3153
-45mV to -55mV	14.7k Ω	0698-3156	2.87k Ω	0698-3151
-55mV to -65mV	16.2k Ω	0757-0447	1.78k Ω	0757-0278
-65mV to -75mV	16.2k Ω	0757-0447	825 Ω	0757-0421
-75mV to -85mV	17.8k Ω	0698-3136	0 Ω	8159-0005

Table B

Reading on the 3465B When A11R3 is Fully CW	A11R1		A11R2	
	Resistance	HP Part No.	Resistance	HP Part No.
-3mV to +5mV	7.50k Ω	0757-0440	10.0k Ω	0757-0442
+5mV to +15mV	6.81k Ω	0757-0439	11.0k Ω	0757-0443
+15mV to +25mV	5.62k Ω	0757-0200	12.1k Ω	0757-0444
+25mV to +35mV	4.64k Ω	0698-3155	13.3k Ω	0757-0289
+35mV to +45mV	3.83k Ω	0698-3153	14.7k Ω	0698-3156
+45mV to +55mV	2.87k Ω	0698-3151	16.2k Ω	0698-3156
+55mV to +65mV	1.78k Ω	0757-0278	16.2k Ω	0757-0447
+65mV to +75mV	825 Ω	0757-0421	16.2k Ω	0757-0447
+75mV to +85mV	0 Ω	8159-0005	17.8k Ω	0698-3136

ADJUSTMENTS

5-25. VCXO ADJUSTMENT (A6)

PURPOSE: This adjustment sets the control voltage for the VCXO so as to set the center frequency of the VCXO to 100MHz.

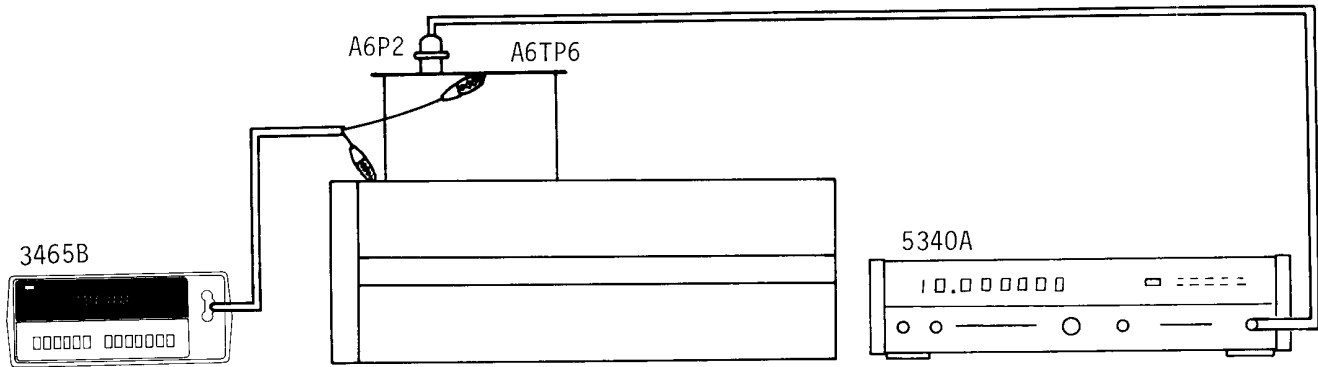

Figure 5-6. VCXO Adjustment Setup.

EQUIPMENT:

Frequency Counter	HP 5340A
DVM	HP 3465B
BNC (female)-SMB (female) adapter	HP P/N 1250-1236
Extender Board	HP P/N 04193-66561
Dual Banana Plug to Alligator Clip Cable	HP 11002A

PROCEDURE:

1. Turn off the 4193A.
2. Disconnect the cables from A6P1 (100MHz REF) and P2 (299.99MHz).
3. Extend the A6 board with an extender board.
4. Connect A6U5 pin 2 to ground.
5. Turn on the 4193A.
6. Connect the DVM input to A6TP6, and the 5340A input to A6P2. Refer to Figure 5-6.
7. Confirm that the dc voltage at A6TP6 is $3.5V \pm 0.35V$.
8. Adjust A6C8 (VCXO ADJ) until the 5340A displays $300MHz \pm 300Hz$.
9. Remove the jumper from between A6U5 pin 2 and ground and confirm that the 5340A displays $299.960MHz \pm 15kHz$. If the displayed frequency is out of range, adjust A6C8 until the 5340A displays $299.960MHz \pm 15kHz$ and then return to step 8.
10. Reinstall the A6 board to its normal position and reconnect the cables (step 2) to A6P1 and P2, respectively.

ADJUSTMENTS

5-26. **BPF OUTPUT LEVEL ADJUSTMENT (A6)**

PURPOSE: This adjustment maximizes the level of the center frequency (299.990MHz) of the BPF on the A6 board which is supplied to the Mixer on the A5 board.

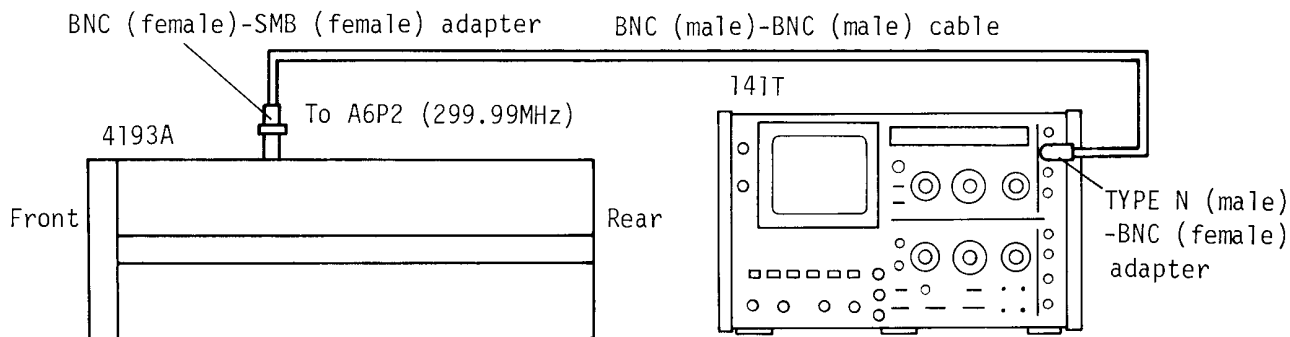

Figure 5-7. BPF Output Level Adjustment Setup.

EQUIPMENT :

Spectrum Analyzer HP 141T with 8552B and 8554B Plug-ins
 TYPE N (male)-BNC (female) Adapter .. HP P/N 1250-1476
 BNC (female)-SMB (female) Adapter HP P/N 1250-1236
 BNC(male) - BNC(male) Cable..... HP 11170C

PROCEDURE :

1. Disconnect the cable from A6P2 (299.99MHz).
2. Connect the RF INPUT terminal of the spectrum analyzer to A6P2 (299.99MHz) as shown in Figure 5-7.
3. Set the spectrum analyzer's controls as described in paragraph 5-22.
4. Adjust A6C7 (BPF ADJ) until the level of the 299.99MHz spectral display on the 141TCRT is maximum.

ADJUSTMENTS

5-27. A2 OUTPUT AMPLIFIER BIAS ADJUSTMENT (A2)

PURPOSE: This adjustment sets the bias voltage for the output amplifier in order to minimize test signal distortion.

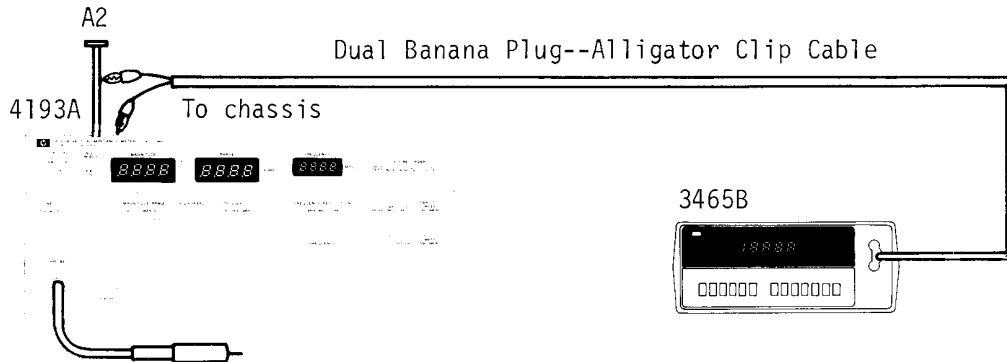

Figure 5-8. A2 Output Amplifier Bias Adjustment Setup.

EQUIPMENT:

Digital Voltmeter HP 3465B
 Extender Board HP P/N 04193-66561
 Dual Banana Plug to Alligator Clip Cable HP 11002A

PROCEDURE:

1. Turn off the 4193A.
2. Extend the A2 board with the extender board.
SMB connector cables need not to be connected to A2P1 and P2.
3. Connect the INPUT terminal of the 3465B to A2TP2 as shown in Figure 5-8.
4. Turn on the 4193A.
5. Set the 3465B's controls as follows :

FUNCTION	== V
RANGE	20V
6. Adjust A2R58 (BIAS ADJ) until the reading on the 3465B is $3V \pm 0.03V$.

ADJUSTMENTS

5-28. SAMPLING PULSE HEIGHT ADJUSTMENT (A1)

PURPOSE: This adjustment sets the height of the V CHANNEL sampling pulse to that of the I CHANNEL sampling pulse in order to equalize sampling efficiency in both channels.

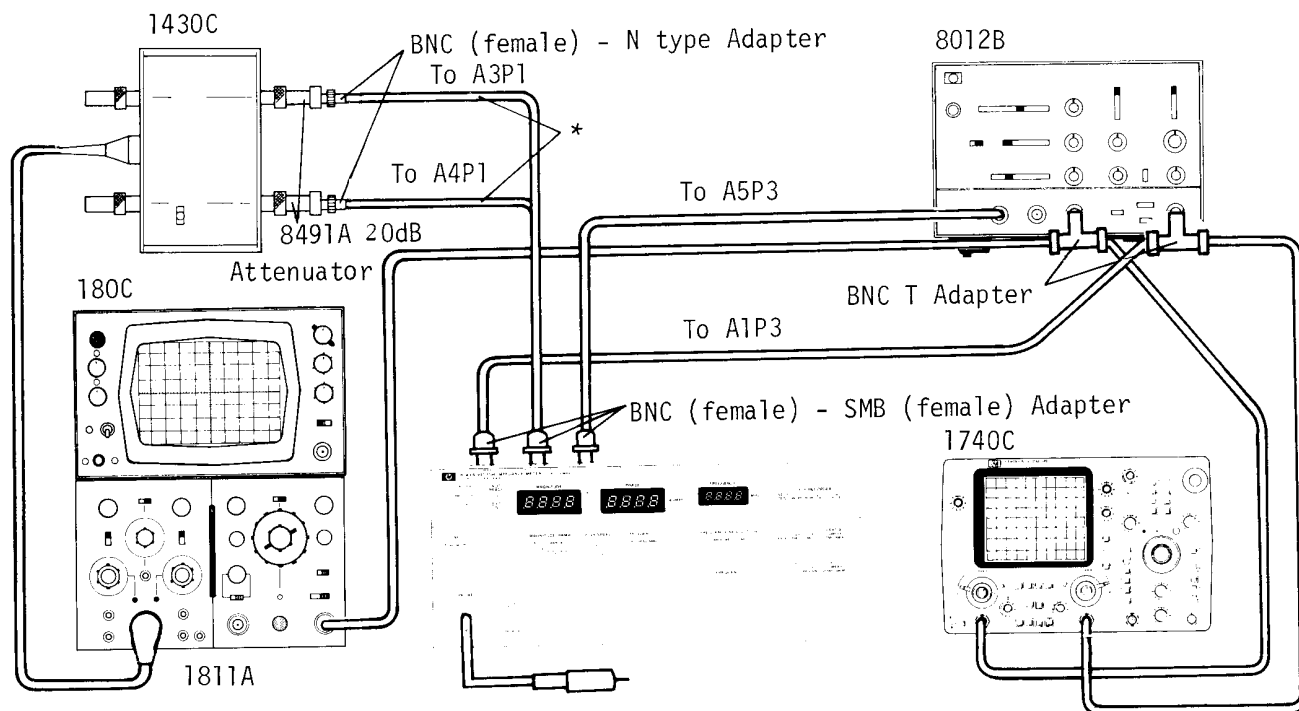

* These cables should be of the same length and less than 30cm long.

Figure 5-9. Sampling Pulse Height Adjustment Setup.

EQUIPMENT:

Sampling Oscilloscope System	HP 180C/1811A	
Sampling Head	HP 1430C	
Pulse Generator	HP 8012B	
Oscilloscope	HP 1740A	
20dB Attenuator (TYPE N)	HP 8491A	2ea.
BNC (female)-TYPE N (male) Adapter	HP P/N 1250-1535	2ea.
BNC (female)-SMB (female) Adapter	HP P/N 1250-1236	4ea.
BNC T Adapter	HP P/N 1250-0781	2ea.
BNC(male) - BNC(male) Cable	HP 11170C,7ea	

ADJUSTMENTS

PROCEDURE

1. Connect all instruments as shown in Figure 5-9.
2. Set the instruments' controls as follows :

4193A :	Trigger	MAN/EXT
	Other Controls	Initial Settings
8012B :	PULSE PERIOD(s)	EXT
	PULSE	NORMAL
	PULSE DELAY(s)	35n - 1 μ
	PULSE WIDTH	10n - 1 μ
	TRANSITION TIME(s)	5n - 0.5 μ
	AMPLITUDE (V)	5.0 - 2.0
	OFFSET (V)	OFF
	POLARITY	-
	SYM/NORM/COMPL	SYM
	INT LOAD	OUT
	All VERNIER Controls	Fully CCW
180C :	MAGNIFIER	x1
	DISPLAY	INT
1811A :	DISPLAY	FILTERED
	MODE	ALT
	POLARITY (Both Channels)	+UP
	mV/DIV (Both Channels)	200
	EXPANDED/DIRECT	DIRECT
	TIME/DIV05 μ sec
	EXPANDED TIME/DIV5nsec
	TRIGGER	AUTO
	MANUAL/SWEEP	SWEEP
	CW SLOPE	+
1740A :	DISPLAY	ALT
	TRIGGER	A
	CHAN A	2V/DIV (DC)
	CHAN B	2V/DIV (DC)
	TIME/DIV	0.2 μ sec
	COUPLING	GND
3. Set the ground reference for CHAN A and CHAN B of the 1740A and the 180C as shown in ① and ②, respectively, of Figure 5-10.
4. Set the 8012B's AMPLITUDE VERNIER to $3V_{P-P}$.
5. Set the 1740A's coupling selectors to DC and confirm that the waveforms displayed on the 1740A and 180C are as shown in ③ and ④, respectively, of Figure 5-10.
6. Adjust the 8012B's PULSE WIDTH VERNIER until the duty cycle of the CHAN B waveform is 50%, as shown in ⑤ of Figure 5-10. The 180C should be as shown in ⑥.
7. Adjust the 8012B's PULSE DELAY VERNIER until the time difference between the peak of the CHAN A waveform and the trailing edge of the CHAN B pulse is 300ns, as shown in ⑦ of Figure 5-10.
8. Rotate the 180C's INTENSITY control knob CCW until the sampling pulses and the marker are displayed on the 180C, as shown in ⑧ of Figure 5-10.
9. Using the 1811A's POSITION control knob, position the marker at the sampling pulses, as shown in ⑩ of Figure 5-10. The 1740A's display should be as shown in ⑨ of Figure 5-10.

ADJUSTMENTS

10. Set the 1811A's TIME/DIV switch to EXPANDED, and adjust the POSITION control knob until the I CHANNEL and V CHANNEL sampling pulses are displayed on the 180C as shown in ① of Figure 5-10.
11. Adjust AIC3(Vp ADJ) until the height of the V CHANNEL sampling pulse is equal to the I CHANNEL sampling pulse height.
12. Confirm that both pulse heights are more than 6.8V.

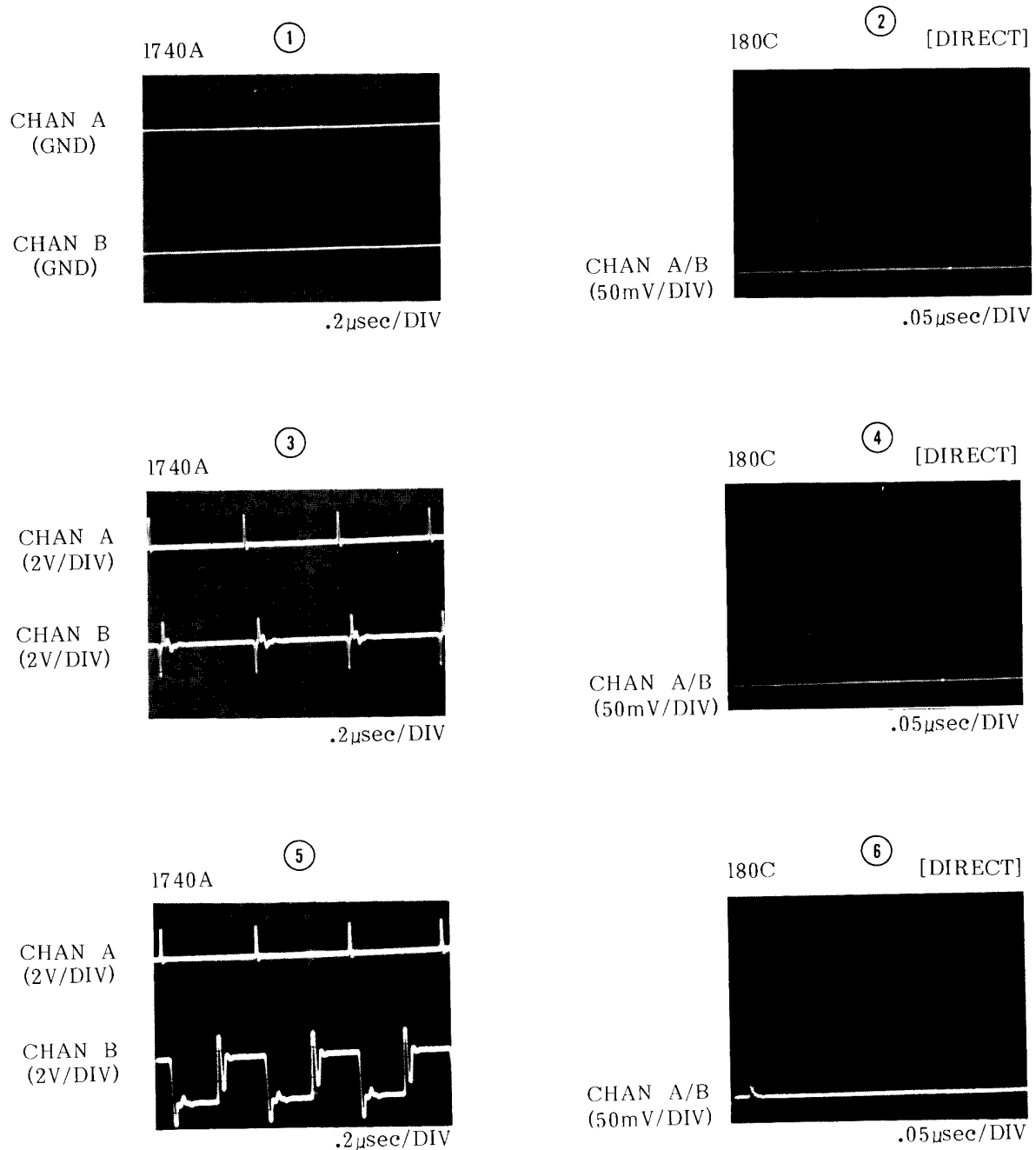

Figure 5-10. Scope Displays (Sheet 1 of 2).

SECTION V

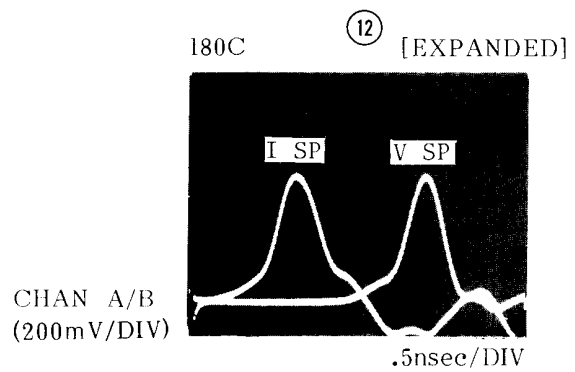
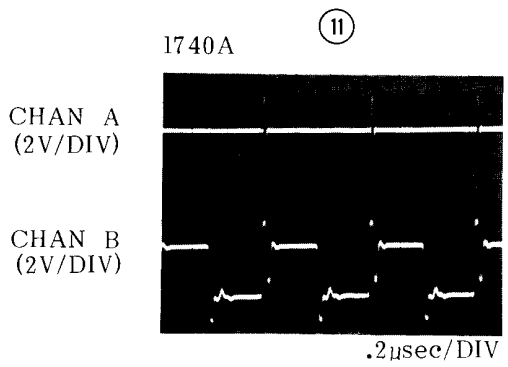
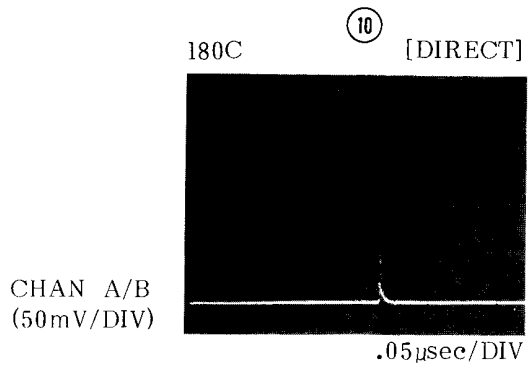
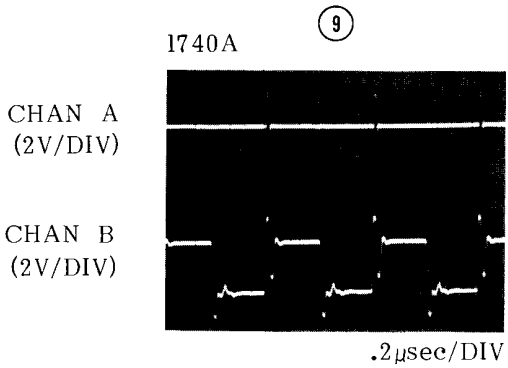
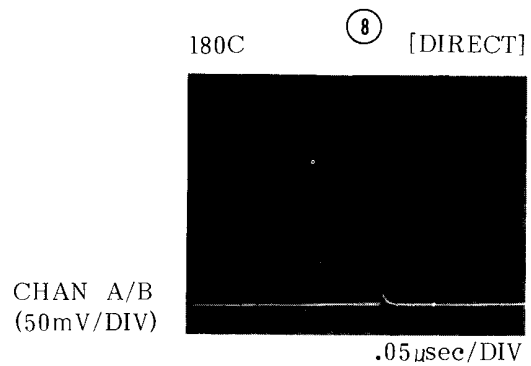
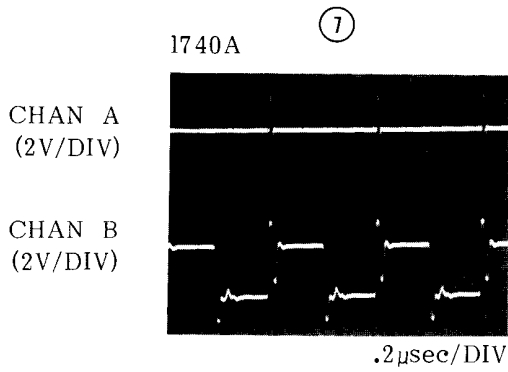

Figure 5-10. Scope Displays (Sheet 2 of 2).

ADJUSTMENTS

5-29. ALC REFERENCE VOLTAGE ADJUSTMENT (A13)

PURPOSE: This adjustment sets the ALC reference voltage so as to supply a precise current level to the DUT.

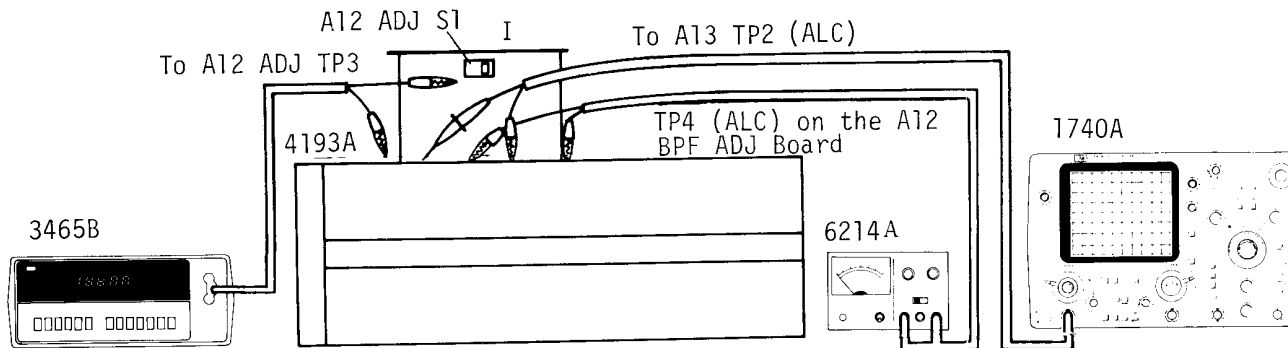

Figure 5-11. ALC Reference Voltage Adjustment Setup.

EQUIPMENT:

DC Power Supply	HP 6214A
Digital Voltmeter	HP 3465B
Oscilloscope	HP 1740A
A12 BPF ADJ Board	HP P/N 04193-66564
Extender Board	HP P/N 04193-66561
Dual Banana Plug to Alligator Clip Cable	HP 11002A,2ea

PROCEDURE:

1. Turn off the 4193A.
2. Remove the A12 and A13 boards.
3. Set the switch on the A12 BPF ADJ board to the I position.
4. Set A13J1 to the T position as shown below :

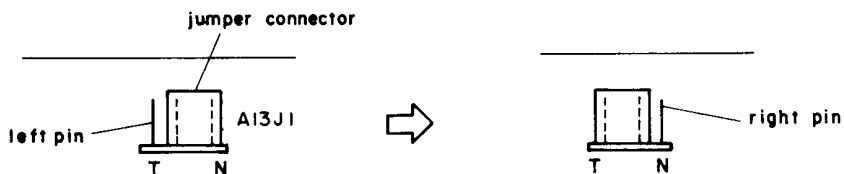

5. Insert the A13 board into the A13 slot.
6. Insert the extender board into the A12 slot and insert the A12 BPF ADJ board into the extender.
7. Connect the 6214A to TP4 on the A12 BPF ADJ Board as shown in the figure

ADJUSTMENTS

8. Connect Channel A of the 1740A to A13TP2, and connect the 3465B to TP3 of A12 BPF ADJ Board as shown in Figure 5-11.
9. Turn on all the instruments and set their controls as follows :
 - 4193A : TRIGGER MAN/EXT
Other Controls Initial Settings
 - 6214A : METER SELECTION VOLTS
 - 3465B : FUNCTION \approx AC
RANGE 2V
 - 1740A : DISPLAY A (DC Coupling)
TRIGGER A
VOLTS/DIV 50mV
TIME/DIV 1ms
10. Adjust the 6214A until the reading on the 3465B is $0.707V_{rms} \pm 1mV_{rms}$.
11. Adjust A13R1 (ALC BIAS) until the trace on the 1740A is $0V \pm 100mV$.

Note

If the IF BPF GAIN/PHASE ADJUSTMENT is to be performed immediately after this adjustment, do not reset A13J1 to the N position.

5-30. IF BPF GAIN/PHASE ADJUSTMENT (A12)

PURPOSE: This adjustment sets the gain and the center frequency of BPF's in the I and V/I channels on the A12 board.

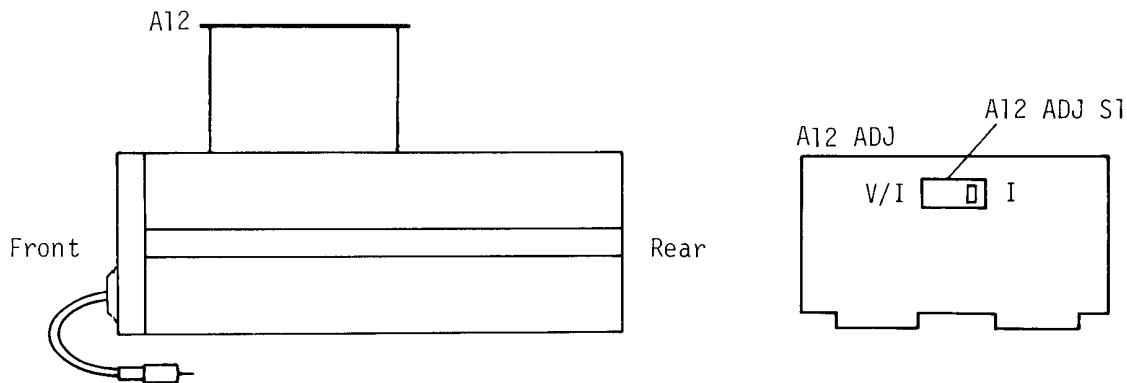

Figure 5-12. IF BPF GAIN/PHASE Adjustment Setup.

EQUIPMENT :

A12 BPF ADJ Board HP P/N 04193-66564

PROCEDURE :

1. Turn off the 4193A.
2. Extend the A12 board with the A12 BPF ADJ board.
Set A13J1 to the T position.
3. Turn on the 4193A.

ADJUSTMENTS

[I channel GAIN and PHASE Adjustment]

4. Set A12 BPF ADJ S1 to the I position.
5. Adjust A12R12 (PHASE I) until the displayed phase is $-7.2 \text{ degrees} \pm 2 \text{ counts}$.
6. Adjust A12R11 (GAIN I) until the displayed magnitude is $100.0\Omega \pm 3 \text{ counts}$.

[V/I Channel GAIN and PHASE Adjustment]

7. Set A12 BPF ADJ S1 to the V/I position.
8. Adjust A12R4 (PHASE V/I) until the displayed phase is $-7.2 \text{ degrees} \pm 2 \text{ counts}$.
9. Adjust A12R3 (GAIN V/I) until the displayed magnitude is $100.0\Omega \pm 3 \text{ counts}$.
Reset A13J1 to the N position.

5-31. I CHANNEL SAMPLING DIODE BIAS ADJUSTMENT (A4)

PURPOSE: This adjustment sets the dc bias voltage applied to the I CHANNEL sampling diodes on the A51 board.

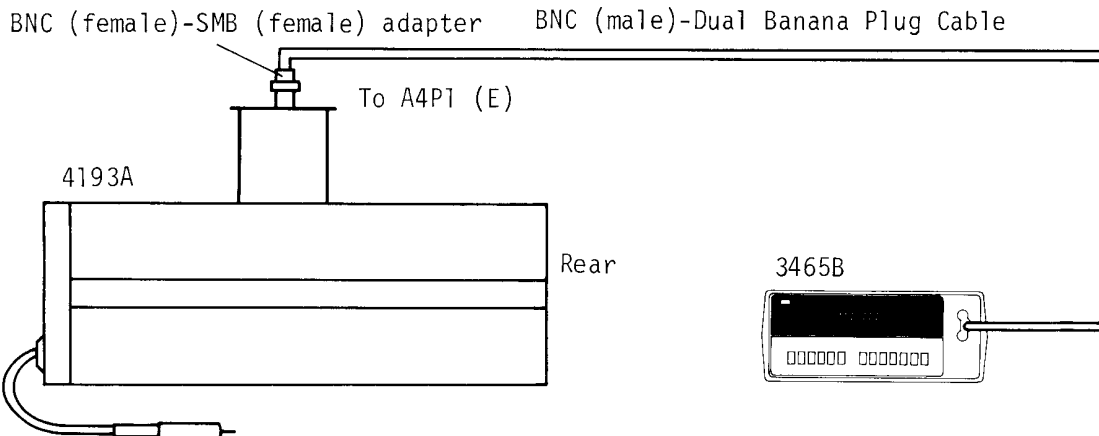

Figure 5-13. I Channel Sampling Diode DC Bias Adjustment Setup.

EQUIPMENT :

Digital Voltmeter	HP3465B
BNC (female)-SMB (female) Adapter	HP P/N 1250-1236
Extender Board	HP P/N 04193-66562
BNC to Dual Banana Plug Cable	HP 11001A

PROCEDURE :

1. Turn off the 4193A.
2. Disconnect the cables from A4P1 (E), A4P2 (I SP IN), and A4P3 (F).
3. Extend the A4 board with the extender board.
4. Connect the INPUT terminal of the 3465B to A4P1 (E) as shown in Figure 5-13.
5. Set the 3465B's controls as follows :

FUNCTION	== V
RANGE	20V
6. Turn on the 4193A : Before turning on, check that the cables are not touching the DC supply terminal.
7. Adjust A4R10 (IB) until the reading on the 3465B is $-3.8V \pm 20mV$.
8. Check that the voltage at A4P3 (F) is $+3.8V \pm 50mV$.

ADJUSTMENTS

5-32. TEST SIGNAL LEVEL ADJUSTMENT (A4)

PURPOSE: This adjustment is made on the ALC so as to supply the specified current to DUT.

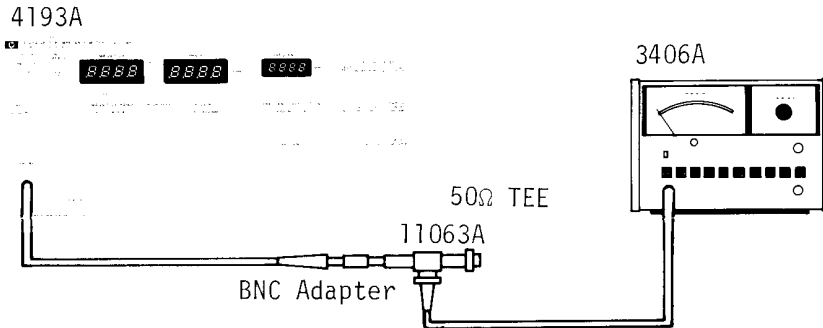

Figure 5-14. Drive Current Level Adjustment Setup.

EQUIPMENT:

RF Voltmeter	HP 3406A
50Ω TEE Adapter	HP 11063A
50Ω Termination (GR 874)	HP P/N 0950-0090
BNC Adapter for 4193A	HP P/N 04193-61152
BNC (female)-GR 874 Adapter	HP P/N 1250-0850

PROCEDURE:

1. Connect the 3406A's probe to the 4193A's probe. Disconnect the cable from A1P1 (V SP). Extend the A4 board.
2. Set the instruments' controls as follows:
 - 4193A: Initial Settings
 - 3406A: Range01V
3. Adjust A4R30 (GAIN) until the reading on the 3406A is $5mV \pm .1mV$.
4. Confirm that the readings on the 3406A are $5mV \pm .5mV$ in the frequency range from .4MHz to 110MHz.

5-33. V CHANNEL SAMPLING DIODE BIAS ADJUSTMENT (A3)

PURPOSE: This adjustment sets the dc bias voltage applied to the V CHANNEL sampling diodes on the A52 board.

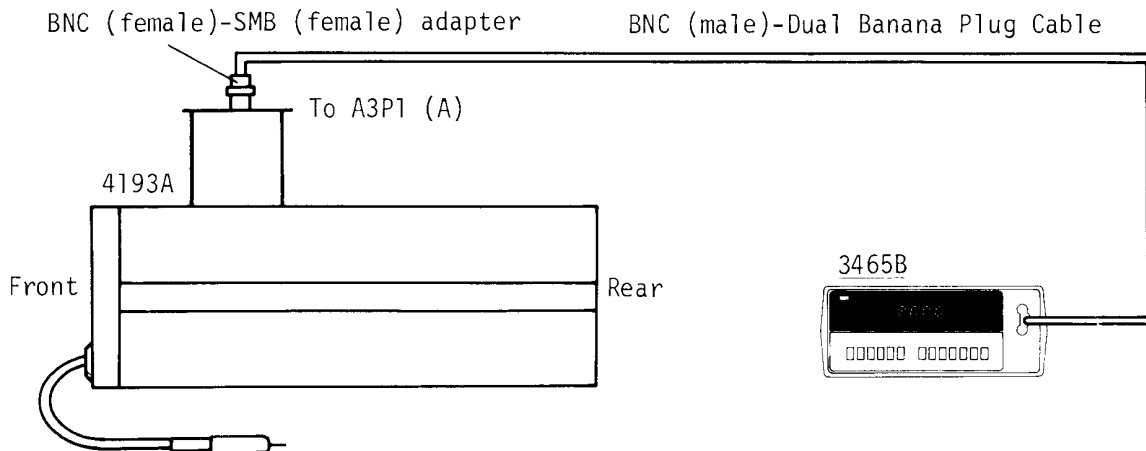

Figure 5-15. V Channel Sampling Diode DC Bias Adjustment Setup.

ADJUSTMENTS

EQUIPMENT :

Digital Voltmeter HP3465B
 BNC (female)-SMB (female) Adapter HP P/N 1250-1236
 Extender Board HP P/N 04193-66562
 BNC(male) - Dual Banana Plug Cable HP 11001A

PROCEDURE :

1. Turn off the 4193A.
2. Disconnect the cables from A3P1 (A), A3P2 (V SP IN) and A3P3 (B).
3. Extend the A3 board with the extender board.
4. Connect the INPUT terminal of the 3465B to A3P1 (A) as shown in Figure 5-15.
5. Set the 3465B's controls as follows :

FUNCTION $\overline{=}$ V
 RANGE 20V

6. Turn on the 4193A.
7. Adjust A3R9 (VB) until the reading on the 3465B is $-3.8V \pm 20mV$.
8. Check that the voltage at A3P3 (B) is $+3.8V \pm 50mV$.

5-34. **MAGNITUDE AND PHASE ACCURACY ADJUSTMENT (A3/A4/A41)**

PURPOSE: This adjustment minimizes MAGNITUDE/PHASE measurement errors. Electrical length is also adjusted.

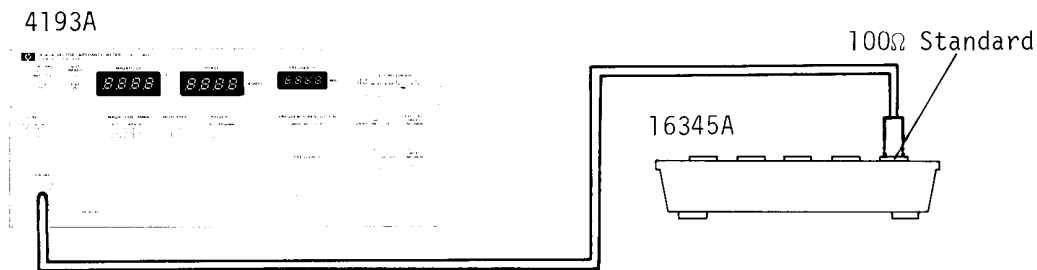

Figure 5-16. Magnitude and Phase Accuracy Adjustment Setup.

EQUIPMENT :

Calibration Standard HP16345A

PROCEDURE :

1. Insert the probe into the 100Ω standard of the 16345A.
2. Set the test frequency to 10MHz.
3. Adjust A3R6 (MAG ADJ) until the value displayed on the MAGNITUDE display is $100.5\Omega \pm 1$ count.
4. Adjust A4R6 (PHASE ADJ) until the value displayed on the PHASE display is 0.0 degrees ± 1 count.

ADJUSTMENTS

Note

The displayed MAGNITUDE value may drift slightly out of the range specified in step 3 when the PHASE adjustment (step 4) is being performed. This is normal, and can be ignored for now. MAGNITUDE accuracy is readjusted in step 8.

5. Set the test frequency to 100MHz, and insert the probe into the OPEN standard of the 16345A.
6. Adjust A4I Delay Line (LENGTH ADJ) until the value displayed on the PHASE display is -90.0 degrees ± 1 count.
7. Reperform steps 1, 2, 4, 5, and 6.
8. Reperform steps 1, 2 and 3.

Note

If a 0.0° (step 4) or -90.0° (step 6) phase display cannot be obtained by adjusting PHASE ADJ, replace the cable between A1P2 and A4P2 with one of the cables listed below, and re-perform this adjustment :

HP Part No.	Cable Length	Remarks
04193-61615	10cm	Increases phase
04193-61616	15cm	Standard cable
04193-61617	20cm	Decreases phase

5-35. RECORDER OUTPUT VOLTAGE ADJUSTMENT (A15)

PURPOSE: This adjustment sets the recorder output voltages for MAGNITUDE, PHASE, and FREQUENCY.

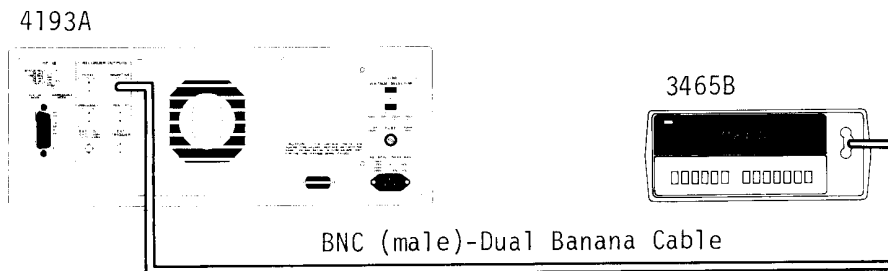

Figure 5-17. Recorder Output Voltage Adjustment Setup.

EQUIPMENT :





- Digital Voltmeter HP3465B
- BNC(male) - Dual Banana Plug Cable HP 11001A

PROCEDURE :

1. Set the 3465B's controls as follows :

FUNCTION \equiv V
 RANGE 2 V

ADJUSTMENTS

2. Connect the INPUT terminal of the 3465B to the MAGNITUDE RECORDER OUTPUT terminal of the 4193A (located on the rear panel).
3. The value displayed on the 3465B should be within $\pm 20\text{mV}$.
4. Press the  key on the 4193A.
5. Adjust A15R2 (M F.S. ADJ) until the reading on the 3465B is + 1V.
6. Connect the INPUT terminal of the 3465B to the PHASE RECORDER OUTPUT terminal.
7. Press the  key.
8. The value displayed on the 3465B should be within $\pm 20\text{mV}$.
9. Press the  key.
10. Adjust A15R3 (P F.S. ADJ) until the reading on the 3465B is + 1V.
11. Connect the INPUT terminal of the 3465B to the FREQUENCY RECORDER OUTPUT terminal.
12. Press the  key.
13. The value displayed on the 3465B should be within $\pm 20\text{mV}$.
14. Press the  key.
15. Adjust A15R1 (F F.S. ADJ) until the reading on the 3465B is + 1V.

SECTION VI

The total quantity for each part is given only once--at the first appearance of the part number in the list.

Part numbers for the shield cases, screws, cable clamps, and cables (except for wiring on a board) on each board assembly, are not listed in Table 6-3. If required these parts must be ordered separately when ordering a complete board assembly. They are listed in Table 6-4 and 6-5 as Board Mounted Hardware and Cable Assemblies respectively.

6-7. ORDERING INFORMATION

6-8. To order a part listed in the replaceable parts table, give the Hewlett-Packard part number, indicate the quantity required, and address the order to the nearest Hewlett-Packard office.

6-9. To order a part that is not listed in the replaceable parts table, state the full instrument model and serial number, and description and function of the part, and the number of parts required. Address your order to the nearest Hewlett-Packard office.

6-10. SPARE PARTS KIT

6-11. Stocking spare parts for an instrument is often done to insure quick return to service after a malfunction occurs. Hewlett-Packard has a Spare Parts Kit available for this purpose. The

kit consists of selected replaceable assemblies and components for this instrument. The contents of the kit and the Recommended Spares List are based on failure reports and repair data, and parts support for one year. A complimentary Recommended Spares List for this instrument may be obtained on request and the Spare Parts Kit may be ordered through your nearest Hewlett-Packard office.

6-12. DIRECT MAIL ORDER SYSTEM

6-13. Within the USA, Hewlett-Packard can supply parts through a direct mail order system. Advantages of using the system are :

- a. Direct ordering and shipment from the HP Parts Center in Mountain View, California.
- b. No maximum or minimum on any mail order (there is a minimum order amount for parts ordered through a local HP Office when the orders require billing and invoicing).
- c. Prepaid transportation (there is a small handling charge for each order).
- d. No invoices--to provide these advantages, a check or money order must accompany each order.

6-14. Mail order forms and specific ordering information are available through your local HP Office. Addresses and phone numbers are located at the back of this manual.

Table 6-2. Manufacturers Code Lists

MFR NO.	MANUFACTURER NAME	ADDRESS	ZIP CODE
00000	ANY SATISFACTORY SUPPLIER		
01121	ALLEN-BRADLEY CO	MILWAUKEE WI	53204
01295	TEXAS INSTR INC SEMICOND CMPNT DIV	DALLAS TX	75222
0192B	RCA CORP SOLID STATE DIV	SOMERVILLE NJ	08876
02111	SPECTROL ELECTRONICS CORP	CITY OF IND CA	91745
02114	FERROXCUBE CORP	SAUGERTIES NY	12477
02768	ILLINOIS TOOL WORKS INC FASTEX DIV	DES PLAINES IL	60016
03888	KDI PYROFILM CORP	WHIPPANY NJ	07981
04713	MOTOROLA SEMICONDUCTOR PRODUCTS	PHOENIX AZ	85062
06383	PANDUIT CORP	TINLEY PARK IL	60477
06665	PRECISION MONOLITHICS INC	SANTA CLARA CA	95050
07716	TRW INC BURLINGTON DIV	BURLINGTON IA	52601
19701	MEPCO/ELECTRA CORP	MINERAL WFLS TX	76067
24046	TRANSITRON ELECTRONIC CORP	WAKEFIELD MA	01880
24355	ANALOG DEVICES INC	NORWOOD MA	02062
24546	CORNING GLASS WORKS (BRADFORD)	BRADFORD PA	16701
26654	VARADYNE INC	SANTA MONICA CA	90404
27014	NATIONAL SEMICONDUCTOR CORP	SANTA CLARA CA	95051
27167	CORNING GLASS WORKS (WILMINGTON)	WILMINGTON NC	28401
28480	HEWLETT-PACKARD CO CORPORATE HQ	PALO ALTO CA	94304
51642	CENTRE ENGINEERING INC	STATE COLLEGE PA	16801
56289	SPRAGUE ELECTRIC CO	NORTH ADAMS MA	01247
72136	ELECTRO MOTIVE CORP SUB IEC	WILLIMANTIC CT	06226
72982	ERIE TECHNOLOGICAL PRODUCTS INC	ERIE PA	16512
74970	JOHNSON E F CO	WASECA MN	56093
75915	LITTELFUSE INC	DES PLAINES IL	60016
8E175	BURR BROWN CO	HUNTSVILLE AL	35801
98291	SEAELECTRO CORP	MAMARONECK NY	10544

Table 6-3. Replaceable Parts

Reference Designation	HP Part Number	C D	Qty	Description	Mfr Code	Mfr Part Number
A1						
A1	34193-66501	0	1	SAMPLING PULSE GENERATOR BOARD ASSEMBLY	28480	34193-66501
A1C1	0160-2437	1	2	CAPACITOR-FDTHRU 5000PF 400 ±2% 200V	28480	0160-2437
A1C2	0160-2437	1	2	CAPACITOR-FDTHRU 5000PF 400 ±2% 200V	28480	0160-2437
A1C3	0121-0453	5	1	CAPACITOR-V TRMR AIR 1.3 5.4PF 125V	74274	187-0303 125
A1C4	0160-4791	4	1	CAPACITOR-FXD 100F ±5% 100VDC CER 31 330	28480	0160-4791
A1C5	0180-0116	1	2	CAPACITOR-FXD 6.8UF±10% 35VDC TA	56237	150665X903502
A1C6	0180-0116	1	2	CAPACITOR-FXD 6.8UF±10% 35VDC TA	56237	150665X903502
A1C7	0160-4793	7	1	CAPACITOR-FXD 5.4PF ±1.5% 160VDC CER	28480	0160-4794
A1C8	0160-0127	2	6	CAPACITOR-FXD 10F ±20% 25VDC CER	28480	3160-0127
A1C9	0160-0174	9	4	CAPACITOR-FXD .47UF 400 20% 25VDC CER	28480	0160-0174
A1C10	0160-0174	9	4	CAPACITOR-FXD .47UF 400 20% 25VDC CER	28480	0160-0174
A1C11	0160-0174	9	4	CAPACITOR-FXD .47UF 400 20% 25VDC CER	28480	0160-0174
A1C12	0180-0994	4	1	CAPACITOR-FXD 1000PF±5-15% 25VDC AL	56237	390137C025002
A1C13	0180-1061	7	2	CAPACITOR-FXD 220 UF 16VDC AL	28480	0180-1061
A1C14	0160-0127	2	2	CAPACITOR-FXD 10F ±20% 25VDC CER	28480	0160-0127
A1C15	0160-0127	2	2	CAPACITOR-FXD 10F ±20% 25VDC CER	28480	0160-0127
A1C16	0160-0174	9	4	CAPACITOR-FXD .47UF 400 20% 25VDC CER	28480	0160-0174
A1C17	0160-0127	2	2	CAPACITOR-FXD 10F ±20% 25VDC CER	28480	0160-0127
A1C18	0160-0127	2	2	CAPACITOR-FXD 10F ±20% 25VDC CER	28480	0160-0127
A1C19	0180-2981	7	2	CAPACITOR-FXD 220 UF 16VDC AL	28480	0180-1061
A1C20	0160-4835	7	2	CAPACITOR-FXD .1UF ±10% 50VDC CER	28480	0160-4835
A1C21	0160-0127	2	2	CAPACITOR-FXD 10F ±20% 25VDC CER	28480	0160-0127
A1C22	0160-4801	7	1	CAPACITOR-FXD 100PF ±5% 100VDC CER	28480	0160-4801
A1C23	0160-4835	7	2	CAPACITOR-FXD .1UF ±10% 50VDC CER	28480	0160-4835
A1CR1	1901-0179	7	2	DIODE-SWITCHING 15V 55MA 750PS DO-7	28480	1901-0179
A1CR2	1901-0179	7	2	DIODE-SWITCHING 15V 55MA 750PS DO-7	28480	1901-0179
A1CR3	1901-0441	6	1	DIODE-STEP RECOVERY	28480	1901-0441
A1CR4	1901-0648	1	1	DIODE-SWITCHING 36V 50MA PWS DO-35	28480	1901-0648
A1L1	9140-3114	4	1	INDUCTOR RF CH-PCD 100H 1% .1660X .3551G	28480	9140-3114
A1L2	9100-3139	5	1	INDUCTOR 750H 1% .50X .875 G	28480	9100-3139
A1Q1	1854-0247	9	6	TRANSISTOR NPN SI TO-39 PB=1W FT=0.09MHZ	28480	1854-0247
A1Q2	1854-0247	9	6	TRANSISTOR NPN SI TO-39 PB=1W FT=0.09MHZ	28480	1854-0247
A1Q3	1854-0319	3	1	TRANSISTOR NPN SI TO-18 PB=360mW	28480	1854-0319
A1Q4	1854-0247	9	6	TRANSISTOR NPN SI TO-39 PB=1W FT=0.09MHZ	28480	1854-0247
A1Q5	1853-0010	2	2	TRANSISTOR PNP SI TO-18 PB=360mW	28480	1853-0010
A1Q6	1853-0010	2	2	TRANSISTOR PNP SI TO-18 PB=360mW	28480	1853-0010
A1Q7	1854-0247	9	6	TRANSISTOR NPN SI TO-39 PB=1W FT=0.09MHZ	28480	1854-0247
A1Q8	1854-0247	9	6	TRANSISTOR NPN SI TO-39 PB=1W FT=0.09MHZ	28480	1854-0247
A1Q9	1854-0247	9	6	TRANSISTOR NPN SI TO-39 PB=1W FT=0.09MHZ	28480	1854-0247
A1Q10	1853-0015	7	1	TRANSISTOR PNP SI PB=200mW FT=500KHZ	28480	1853-0015
A1R1	0693-4725	2	2	RESISTOR 4.7K 5% .25W FC TC=400/±700	01121	064725
A1R2	0693-6815	5	2	RESISTOR 680 5% .25W FC TC=400/±500	01121	066815
A1R3	0693-4725	2	2	RESISTOR 4.7K 5% .25W FC TC=400/±700	01121	064725
A1R4	0693-5665	9	7	RESISTOR 56 5% .25W FC TC=400/±500	01121	065665
A1R5	0757-0420	3	1	RESISTOR 750 1% .125W F TC=0±100	24546	04 1/8 TO-251 F
A1R6	0757-0442	9	1	RESISTOR 10K 1% .125W F TC=0±100	24546	04 1/8 TO-251 F
A1R7	0693-5665	9	7	RESISTOR 56 5% .25W FC TC=400/±500	01121	065665
A1R8	0693-5665	9	7	RESISTOR 56 5% .25W FC TC=400/±500	01121	065665
A1R9	0693-5665	9	7	RESISTOR 56 5% .25W FC TC=400/±500	01121	065665
A1R10	0693-5665	9	7	RESISTOR 56 5% .25W FC TC=400/±500	01121	065665
A1R11	0757-0280	3	2	RESISTOR 1K 1% .125W F TC=0±100	24546	04 1/8 TO-1811 F
A1R12	0757-0401	0	1	RESISTOR 100 1% .125W F TC=0±100	24546	04 1/8 TO-1811 F
A1R13	0693-3153	9	1	RESISTOR 3.15K 1% .125W F TC=0±100	24546	04 1/8 TO-3601 F
A1R14	0693-5665	9	7	RESISTOR 56 5% .25W FC TC=400/±500	01121	065665
A1R15	0757-0277	0	1	RESISTOR 49.9 1% .125W F TC=0±100	24546	04 1/8 TO-4502 F
A1R16	0757-0417	0	1	RESISTOR 500 1% .125W F TC=0±100	24546	04 1/8 TO-5012 F
A1R17	0693-2705	4	2	RESISTOR 27 5% .25W FC TC=400/±500	01121	062705
A1R18	0757-0346	2	2	RESISTOR 16 1% .125W F TC=0±100	24546	04 1/8 TO-1000 F
A1R19	0693-2705	4	2	RESISTOR 27 5% .25W FC TC=400/±500	01121	062705
A1R20	0757-0346	2	2	RESISTOR 16 1% .125W F TC=0±100	24546	04 1/8 TO-1000 F

See introduction to this section for ordering information.
*Indicates factory selected value

Table 6-3. Replaceable Parts

Reference Designation	HP Part Number	C D	Qty	Description	Mfr Code	Mfr Part Number
A1R21	0693-6815	5		RESISTOR 480 5% .125W FC TC=+400/+600	01121	CB6815
A1R22	0757-0280	3		RESISTOR 1K 1% .125W F TC=0+-100	24546	C4-1/8-T0-1001-F
A1R23	0693-6695	9		RESISTOR 56 5% .125W FC TC=+400/+500	01121	CB5695
A1R24	0698-3613	6	2	RESISTOR 32 5% 2W KO TC=0+-200	27167	FP42-2-T00-39R0-J
A1R25	0698-3613	6		RESISTOR 32 5% 2W KO TC=0+-200	27167	FP42-2-T00-39R0-J
	04193-26501	0	1	PCBD BLANK	28480	04193-26501
				MISCELLANEOUS PARTS		
	9170-0029	3	6	CORE-SHIELDING BEAD	28480	9170-0029
	1205-0050	7	2	HEAT SINK T0-5/T0-39-CS	28480	1205-0050
	04193-60001	3	1	COVER	28480	04193-60001
	04193-61623	7	1	CABLE ASSEMBLY	28480	04193-61623
	04193-66541	8	1	PCB ASSEMBLY-DELAY	28480	04193-66541
A1R26	2100-3212		1	RESISTOR -TRMR 200 10%		
A1R27	0757-0442		1	RESISTOR 10K 1% .125W		

See introduction to this section for ordering information
 *Indicates factory selected value

Table 6-3. Replaceable Parts

Reference Designation	HP Part Number	C D	Qty	Description	Mfr Code	Mfr Part Number
A2						
A2	04193-66502	1	1	ALC AMPLIFIER BOARD ASSEMBLY	28480	04193-66502
A2C1	0160-2437	1	2	CAPACITOR-FDTHRU 5000PF +80 -20% 200V	28480	0160-2437
A2C2	0160-2437	1	2	CAPACITOR-FDTHRU 5000PF +80 -20% 200V	28480	0160-2437
A2C3	0160-4387	4	2	CAPACITOR-FXD 47PF +-5% 200VDC CER 0+-30	28480	0160-4387
A2C4	0160-4832	4	7	CAPACITOR-FXD .01UF +-10% 100VDC CER	28480	0160-4832
A2C5	0160-4835	7	23	CAPACITOR-FXD .1UF +-10% 50VDC CER	28480	0160-4835
A2C6	0160-4387	4	2	CAPACITOR-FXD 47PF +-5% 200VDC CER 0+-30	28480	0160-4387
A2C7	0160-4835	7	2	CAPACITOR-FXD .1UF +-10% 50VDC CER	28480	0160-4835
A2C8	0160-0263	7	2	CAPACITOR-FXD .22UF +-20% 50VDC CER	28480	0160-0263
A2C9	0160-4835	7	2	CAPACITOR-FXD .1UF +-10% 50VDC CER	28480	0160-4835
A2C10	0160-4835	7	2	CAPACITOR-FXD .1UF +-10% 50VDC CER	28480	0160-4835
A2C11	0160-4835	7	2	CAPACITOR-FXD .1UF +-10% 50VDC CER	28480	0160-4835
A2C12	0160-4835	7	2	CAPACITOR-FXD .1UF +-10% 50VDC CER	28480	0160-4835
A2C13	0160-4835	7	2	CAPACITOR-FXD .1UF +-10% 50VDC CER	28480	0160-4835
A2C14	0160-4832	4	2	CAPACITOR-FXD .01UF +-10% 100VDC CER	28480	0160-4832
A2C15	0160-4835	7	2	CAPACITOR-FXD .1UF +-10% 50VDC CER	28480	0160-4835
A2C16	0160-0263	7	2	CAPACITOR-FXD .22UF +-20% 50VDC CER	28480	0160-0263
A2C17	0160-4835	7	2	CAPACITOR-FXD .1UF +-10% 50VDC CER	28480	0160-4835
A2C18	0160-4835	7	2	CAPACITOR-FXD .1UF +-10% 50VDC CER	28480	0160-4835
A2C19	0160-4835	7	2	CAPACITOR-FXD .1UF +-10% 50VDC CER	28480	0160-4835
A2C20	0160-4835	7	2	CAPACITOR-FXD .1UF +-10% 50VDC CER	28480	0160-4835
A2C21	0160-4832	4	2	CAPACITOR-FXD .01UF +-10% 100VDC CER	28480	0160-4832
A2C22	0160-4835	7	2	CAPACITOR-FXD .1UF +-10% 50VDC CER	28480	0160-4835
A2C23	0160-4835	7	2	CAPACITOR-FXD .1UF +-10% 50VDC CER	28480	0160-4835
A2C24	0160-4832	4	2	CAPACITOR-FXD .01UF +-10% 100VDC CER	28480	0160-4832
A2C25	0160-4835	7	2	CAPACITOR-FXD .1UF +-10% 50VDC CER	28480	0160-4835
A2C26	0160-4835	7	2	CAPACITOR-FXD .1UF +-10% 50VDC CER	28480	0160-4835
A2C27	0160-4835	7	2	CAPACITOR-FXD .1UF +-10% 50VDC CER	28480	0160-4835
A2C28	0160-4835	7	2	CAPACITOR-FXD .1UF +-10% 50VDC CER	28480	0160-4835
A2C29	0160-4787	7	2	CAPACITOR-FXD 22PF	28480	0160-4787
A2C30	0160-4835	7	2	CAPACITOR-FXD .1UF +-10% 50VDC CER	28480	0160-4835
A2C31	0160-4835	7	2	CAPACITOR-FXD .1UF +-10% 50VDC CER	28480	0160-4835
A2C32	0160-4832	4	2	CAPACITOR-FXD .01UF +-10% 100VDC CER	28480	0160-4832
A2C33	0160-4835	7	2	CAPACITOR-FXD .1UF +-10% 50VDC CER	28480	0160-4835
A2C34	0180-0116	1	2	CAPACITOR-FXD 6.8UF+-10% 35VDC	56289	150D68X9035B2
A2C35	0160-4792	5	2	CAPACITOR-FXD 8.2PF +-1.5PF 100VDC CER	28480	0160-4792
A2C36	0160-4835	7	2	CAPACITOR-FXD .1UF +-10% 50VDC CER	28480	0160-4835
A2C37	0180-1083	3	2	CAPACITOR-FXD 33UF 25VDC AL	28480	0180-1083
A2C38	0180-0197	8	1	CAPACITOR-FXD 2.2UF+-10% 20VDC TA	56289	150D22X9020A2
A2C39	0160-4835	7	2	CAPACITOR-FXD .1UF +-10% 50VDC CER	28480	0160-4835
A2C40	0160-4832	4	2	CAPACITOR-FXD .01UF +-10% 100VDC CER	28480	0160-4832
A2C41	0160-4832	4	2	CAPACITOR-FXD .01UF +-10% 100VDC CER	28480	0160-4832
A2C42	0180-1083	3	2	CAPACITOR-FXD 33UF 25VDC AL	28480	0180-1083
A2CR1	1901-0639	4	8	DIODE-PIN	28480	5082-3080
A2CR2	1901-0639	4	8	DIODE-PIN	28480	5082-3080
A2CR3	1901-0639	4	8	DIODE-PIN	28480	5082-3080
A2CR4	1901-0639	4	8	DIODE-PIN	28480	5082-3080
A2CR5	1901-0639	4	8	DIODE-PIN	28480	5082-3080
A2CR6	1901-0639	4	8	DIODE-PIN	28480	5082-3080
A2CR7	1901-0639	4	8	DIODE-PIN	28480	5082-3080
A2CR8	1901-0639	4	8	DIODE-PIN	28480	5082-3080
A2CR9	1901-0040	1	3	DIODE-SWITCHING 30V 50MA 2NS DO-35	28480	1901-0040
A2CR10	1901-0040	1	3	DIODE-SWITCHING 30V 50MA 2NS DO-35	28480	1901-0040
A2CR11	1901-0040	1	3	DIODE-SWITCHING 30V 50MA 2NS DO-35	28480	1901-0040
A2CR12	1902-3005	6	1	DIODE-ZNR 2.43V 5% DO-7 PD= 4W TD= .026Z	28480	1902-3005
A2J1	1251-5862	6	1	CONNECTOR 4 PIN M METRIC POST TYPE	28480	1251-5862
A2K1	0490-1269	4	2	RELAY 1C 12VDC-COIL .66A 30VDC	28480	0490-1269
A2K2	0490-1269	4	2	RELAY 1C 12VDC-COIL .66A 30VDC	28480	0490-1269
A2L1	9100-1615	8	4	INDUCTOR RE-CH MFD 1.20H 10Z	28480	9100-1615
A2L2	9100-1615	8	4	INDUCTOR RE-CH MFD 1.20H 10Z	28480	9100-1615
A2L3	9100-1615	8	4	INDUCTOR RE-CH MFD 1.20H 10Z	28480	9100-1615
A2L4	9100-1615	8	4	INDUCTOR RE-CH MFD 1.20H 10Z	28480	9100-1615
A2L6	9100-1618	1	2	INDUCTOR RE-CH MFD 5.60H 10Z	28480	9100-1618
A2L7	9100-1618	1	2	INDUCTOR RE-CH MFD 5.60H 10Z	28480	9100-1618
A2L8	9100-2249	6	2	INDUCTOR RE-CH MFD 1500H 10Z .105DX.261C	28480	9100-2249
A2M1	1854-0345	8	6	TRANSISTOR NPN 2N5179 SI 10 7Z PD=200MW	04713	2N5179
A2M2	1854-0310	2	2	TRANSISTOR NPN SI PD=625MW FT=200MHZ	28480	1854-0310
A2M3	1854-0345	8	6	TRANSISTOR NPN 2N5179 SI 10 7Z PD=200MW	04713	2N5179
A2M4	1854-0310	2	2	TRANSISTOR NPN SI PD=625MW FT=200MHZ	28480	1854-0310
A2M5	1854-0345	8	6	TRANSISTOR NPN 2N5179 SI 10 7Z PD=200MW	04713	2N5179

See introduction to this section for ordering information
 *Indicates factory selected value

Table 6-3. Replaceable Parts

Reference Designation	HP Part Number	C D	Qty	Description	Mfr Code	Mfr Part Number
A206	1854-0345	8		TRANSISTOR NPN 2N5179 SI TO-72 PD=200mW	04213	2N5179
A207	1854-0345	8		TRANSISTOR NPN 2N5179 SI TO-72 PD=200mW	04213	2N5179
A208	1854-0247	8		TRANSISTOR NPN		
A209	1854-0597	2	2	TRANSISTOR NPN 2N5943 SI TO-39 PD=1W	04213	2N5943
A210	1854-0597	2		TRANSISTOR NPN 2N5943 SI TO-39 PD=1W	04213	2N5943
A2R1	0683-4705	8	5	RESISTOR 47 5% .25W FC TC=-400/+500	01121	CR4705
A2R2	0683-5605	9	1	RESISTOR 56 5% .25W FC TC=-400/+500	01121	CR5605
A2R3	0698-3152	8	2	RESISTOR 3.48K 1% .125W F TC=0+-100	24546	C4-1/8-T0-3481-F
A2R4	0757-0428	1	2	RESISTOR 1.62K 1% .125W F TC=0+-100	24546	C4-1/8-T0-1621-F
A2R5	0683-6815	5	3	RESISTOR 680 5% .25W FC TC=-400/+600	01121	CR6815
A2R6	0683-2215	1	5	RESISTOR 220 5% .25W FC TC=-400/+600	01121	CR2215
A2R7	0683-2215	1		RESISTOR 220 5% .25W FC TC=-400/+600	01121	CR2215
A2R8	0698-4037	0	1	RESISTOR 46.4 1% .125W F TC=0+-100	24546	C4-1/8-T0-46R4-F
A2R9	0698-3152	8		RESISTOR 3.48K 1% .125W F TC=0+-100	24546	C4-1/8-T0-3481-F
A2R10	0757-0428	1		RESISTOR 1.62K 1% .125W F TC=0+-100	24546	C4-1/8-T0-1621-F
A2R11	0757-0394	0	3	RESISTOR 51.1 1% .125W F TC=0+-100	24546	C4-1/8-T0-51R1-F
A2R12	0698-3155	1	4	RESISTOR 4.64K 1% .125W F TC=0+-100	24546	C4-1/8-T0-4641-F
A2R13	0698-3155	1		RESISTOR 4.64K 1% .125W F TC=0+-100	24546	C4-1/8-T0-4641-F
A2R14	0683-4705	8		RESISTOR 47 5% .25W FC TC=-400/+500	01121	CR4705
A2R15	0683-2215	1		RESISTOR 220 5% .25W FC TC=-400/+600	01121	CR2215
A2R16	0683-6815	5		RESISTOR 680 5% .25W FC TC=-400/+600	01121	CR6815
A2R17	0698-4386	2	1	RESISTOR 59 1% .125W F TC=0+-100	24546	C4-1/8-T0-59R0-F
A2R18	0683-2215	1		RESISTOR 220 5% .25W FC TC=-400/+600	01121	CR2215
A2R19	0757-0394	0		RESISTOR 51.1 1% .125W F TC=0+-100	24546	C4-1/8-T0-51R1-F
A2R20	0698-3155	1		RESISTOR 4.64K 1% .125W F TC=0+-100	24546	C4-1/8-T0-4641-F
A2R21	0698-3155	1		RESISTOR 4.64K 1% .125W F TC=0+-100	24546	C4-1/8-T0-4641-F
A2R22	0757-0417	8	1	RESISTOR 562 1% .125W F TC=0+-100	24546	C4-1/8-T0-562R-F
A2R23	0757-0280	3	1	RESISTOR 1K 1% .125W F TC=0+-100	24546	C4-1/8-T0-1001-F
A2R24	0698-4442	1	3	RESISTOR 4.42K 1% .125W F TC=0+-100	24546	C4-1/8-T0-4421-F
A2R25	0698-4014	3	1	RESISTOR 787 1% .125W F TC=0+-100	24546	C4-1/8-T0-787R-F
A2R26	0698-4469	2	2	RESISTOR 1.15K 1% .125W F TC=0+-100	24546	C4-1/8-T0-1151-F
A2R27	0698-4442	1		RESISTOR 4.42K 1% .125W F TC=0+-100	24546	C4-1/8-T0-4421-F
A2R28	0757-0422	5	1	RESISTOR 909 1% .125W F TC=0+-100	24546	C4-1/8-T0-909R-F
A2R29	0698-4442	1		RESISTOR 4.42K 1% .125W F TC=0+-100	24546	C4-1/8-T0-4421-F
A2R30	0683-4705	8		RESISTOR 47 5% .25W FC TC=-400/+500	01121	CR4705
A2R31	0683-2215	1		RESISTOR 220 5% .25W FC TC=-400/+600	01121	CR2215
A2R32	0698-3432	7	1	RESISTOR 26.1 1% .125W F TC=0+-100	03308	PM55-1/8-T0-26R1-F
A2R33	0757-0412	3	1	RESISTOR 365 1% .125W F TC=0+-100	24546	C4-1/8-T0-365R-F
A2R34	0757-0409	8	1	RESISTOR 274 1% .125W F TC=0+-100	24546	C4-1/8-T0-274R-F
A2R35	0683-1005	5	1	RESISTOR 10 5% .25W FC TC=-400/+500	01121	CR1005
A2R36	0698-4469	2		RESISTOR 1.15K 1% .125W F TC=0+-100	24546	C4-1/8-T0-1151-F
A2R37	0698-3443	0	1	RESISTOR 287 1% .125W F TC=0+-100	24546	C4-1/8-T0-287R-F
A2R38	0683-1015	0	1	RESISTOR 100		
A2R39	0698-3444	1	1	RESISTOR 316 1% .125W F TC=0+-100	24546	C4-1/8-T0-316R-F
A2R41	0683-5615	5		RESISTOR 560		
A2R42	0683-4705	8		RESISTOR 47 5% .25W FC TC=-400/+500	01121	CR4705
A2R43	0698-3402	1	2	RESISTOR 316 1% .15W F TC=0+-100	28480	0698-3402
A2R44	0698-3402	1		RESISTOR 316 1% .15W F TC=0+-100	28480	0698-3402
A2R45	0683-1055	5	1	RESISTOR 10 5% .25W FC TC=-300/+900	01121	CR1055
A2R46	0698-4413	6	2	RESISTOR 154 1% .125W F TC=0+-100	24546	C4-1/8-T0-154R-F
A2R47	0698-4413	6		RESISTOR 154 1% .125W F TC=0+-100	24546	C4-1/8-T0-154R-F
A2R48	0683-4705	8		RESISTOR 47 5% .25W FC TC=-400/+500	01121	CR4705
A2R49	0698-3437	2	4	RESISTOR 133 1% .125W F TC=0+-100	24546	C4-1/8-T0-133R-F
A2R50	0698-3437	2		RESISTOR 133 1% .125W F TC=0+-100	24546	C4-1/8-T0-133R-F
A2R51	0698-3437	2		RESISTOR 133 1% .125W F TC=0+-100	24546	C4-1/8-T0-133R-F
A2R52	0598-3437	2		RESISTOR 133 1% .125W F TC=0+-100	24546	C4-1/8-T0-133R-F
A2R53	0683-1215	0		RESISTOR 120 5% .25W FC TC=-400/+600	01121	CR1215
A2R54	0757-0394	0		RESISTOR 51.1 1% .125W F TC=0+-100	24546	C4-1/8-T0-51R1-F
A2R55	0683-3315	4	1	RESISTOR 330 5% .25W FC TC=-400/+600	01121	CR3315
A2R56	0698-4460	3	1	RESISTOR 649 1% .125W F TC=0+-100	24546	C4-1/8-T0-649R-F
A2R57	0698-4467	0	1	RESISTOR 1.05K 1% .125W F TC=0+-100	24546	C4-1/8-T0-1051-F
A2R58	2100-0562	0	1	RESISTOR-100R 5% 10% C THP-ADJ 1-100	20480	2100-0562
A2U1	1020-1144	6	1	IC GATE TTL LS NOR QUAD 2-IMP	01295	SN74LS02N
A2U2	1020-0471	0	1	IC INV TTL HEX 1-IMP	01295	SN7404N
	1205-0050	7	2	HEAT SINK TO-5/TO-39-CS	28480	1205-0050
	5001-0176	7	2	STRAP-GROUND	20480	5001-0176
	04193-60002	4	1	COVER	20480	04193-60002
	04193-26502	0	1	PCBD BLANK	28480	04193-26502
A2W1	8159-0005		1	JUMPLER		

See introduction to this section for ordering information
 *Indicates factory selected value

Table 6-3. Replaceable Parts

Reference Designation	HP Part Number	C D	Qty	Description	Mfr Code	Mfr Part Number
A3						
A3	04193-66503	2	1	V-CHANNEL AMPLIFIER BOARD ASSEMBLY	20480	04193-66503
A3C1	0160-0570	2	2	CAPACITOR-FXD 220PF +/-20% 100VDC CER	20480	0160-0570
A3C2	0160-3877	5	2	CAPACITOR-FXD 100PF +/-20% 100VDC CER	20480	0160-3877
A3C3	0160-0570	2	2	CAPACITOR-FXD 220PF +/-20% 100VDC CER	20480	0160-0570
A3C4	0160-3877	5	2	CAPACITOR-FXD 100PF +/-20% 100VDC CER	20480	0160-3877
A3C5	0160-3878	6	1	CAPACITOR-FXD 1000PF +/-20% 100VDC CER	20480	0160-3878
A3C6	0160-4835	7	6	CAPACITOR-FXD .1UF +/-10% 50VDC CER	20480	0160-4835
A3C7	0160-0127	2	3	CAPACITOR-FXD .1UF +/-20% 25VDC CER	20480	0160-0127
A3C8	0160-0127	2	3	CAPACITOR-FXD .1UF +/-20% 25VDC CER	20480	0160-0127
A3C9	0180-1083	3	5	CAPACITOR-FXD .33UF 25VDC AL	20480	0180-1083
A3C10	0160-4386	3	1	CAPACITOR-FXD .33PF +/-5% 200VDC CER 0+-30	51642	200-200-NP8-330F
A3C11	0180-1083	3	3	CAPACITOR-FXD .33UF 25VDC AL	20480	0180-1083
A3C12	0180-1083	3	3	CAPACITOR-FXD .33UF 25VDC AL	20480	0180-1083
A3C13	0160-0127	2	2	CAPACITOR-FXD .1UF +/-20% 25VDC CER	20480	0160-0127
A3C14	0160-4832	4	1	CAPACITOR-FXD .018UF +/-10% 100VDC CER	20480	0160-4832
A3C15	0180-0373	1	1	CAPACITOR-FXD .68UF +/-10% 35VDC TA	56289	150D684X9035A2
A3C16	0180-0291	3	1	CAPACITOR-FXD .1UF +/-10% 35VDC TA	56289	150D105X9035A2
A3C17	0180-3153	1	1	CAPACITOR-FXD .10UF +/-20% 25VDC TA		
A3C18	0160-4835	7	7	CAPACITOR-FXD .1UF +/-10% 50VDC CER	20480	0160-4835
A3C19	0160-4835	7	7	CAPACITOR-FXD .1UF +/-10% 50VDC CER	20480	0160-4835
A3C20	0160-4835	7	7	CAPACITOR-FXD .1UF +/-10% 50VDC CER	20480	0160-4835
A3C21	0160-4835	7	7	CAPACITOR-FXD .1UF +/-10% 50VDC CER	20480	0160-4835
A3C22	0160-4835	7	7	CAPACITOR-FXD .1UF +/-10% 50VDC CER	20480	0160-4835
A3C23	0180-1083	3	3	CAPACITOR-FXD .33UF 25VDC AL	20480	0180-1083
A3C24	0180-1083	3	3	CAPACITOR-FXD .33UF 25VDC AL	20480	0180-1083
A3CR1	1901-0179	7	1	DIODE-SWITCHING 15V 50MA 250PS D0-7	20480	1901-0179
A3J1	1251-5862	6	1	CONNECTOR 4-PIN M METRIC POST TYPE	20480	1251-5862
A3J2	1251-6527	2	1	CONNECTOR 6-PIN M METRIC POST TYPE	20480	1251-6527
A3L1	9140-0114	4	4	INDUCTOR RF-CH-MLD 10UH 10% .166DX.385LC	20480	9140-0114
A3L2	9140-0114	4	4	INDUCTOR RF-CH-MLD 10UH 10% .166DX.385LC	20480	9140-0114
A3L3	9140-0114	4	4	INDUCTOR RF-CH-MLD 10UH 10% .166DX.385LC	20480	9140-0114
A3L4	9140-0114	4	4	INDUCTOR RF-CH-MLD 10UH 10% .166DX.385LC	20480	9140-0114
A3Q1	1054-0129	6	1	TRANSISTOR-NPN 2SC1636	20480	1054-0129
A3Q2	1054-0477	7	1	TRANSISTOR NPN 2N2222A SI TO-18 PB=500MW	04713	2N2222A
A3Q3	1053-0281	9	1	TRANSISTOR PNP 2N2907A SI TO-18 PB=400MW	04713	2N2907A
A3R1	0698-3155			RESISTOR 4.7K 1% .25W FC TC=-400/+600	01121	
A3R2	0698-7205			RESISTOR 51 .25W FC TC=-400/+500	01121	
A3R3	0683-4715	0	1	RESISTOR 470 5% .25W FC TC=-400/+600	01121	CR4715
A3R4	0698-7205			RESISTOR 51 .25W FC TC=-400/+500	01121	
A3R5	0698-3155	2	1	RESISTOR 4.7 .25W FC TC=-400/+600	01121	
A3R6	2100-3109		1	RESISTOR-TMR 2K 10% C SIDE-ADJ 1-TRN	20480	2100-3109
A3R7	0683-5105	4		RESISTOR 51 5% .25W FC TC=-400/+500	01121	CR5105
A3R8	0683-5105	4		RESISTOR 51 5% .25W FC TC=-400/+500	01121	CR5105
A3R9	2100-3352	7	1	RESISTOR-TMR 1K 10% C SIDE-ADJ 1-TRN	20480	2100-3352
A3R10	0698-4158	6	2	RESISTOR 100K .1% .125W F TC=0+-50	20480	0698-4158
A3R11	0698-4158	6		RESISTOR 100K .1% .125W F TC=0+-50	20480	0698-4158
A3R12	0683-1025	9	1	RESISTOR 1K 5% .25W FC TC=-400/+600	01121	CR1025
A3R13	0698-3152	8	1	RESISTOR 3.48K 1% .125W F TC=0+-100	24546	C4-1/8-10-3481-F
A3R14	0757-0421	4	1	RESISTOR 825 1% .125W F TC=0+-100	24546	C4-1/8-10-825-F
A3R15	0757-0465	6	1	RESISTOR 100K 1% .125W F TC=0+-100	24546	C4-1/8-10-100-F
A3R16	0757-0317	7	1	RESISTOR 1.33K 1% .125W F TC=0+-100	24546	C4-1/8-10-1331-F
A3R17	0698-3153	9	1	RESISTOR 3.03K 1% .125W F TC=0+-100	24546	C4-1/8-10-3031-F
A3R18	0683-4725	2		RESISTOR 4.7K 5% .25W FC TC=-400/+200	01121	CR4725
A3R19	0683-4725	2		RESISTOR 4.7K 5% .25W FC TC=-400/+200	01121	CR4725
A3R20	0683-2225	3	2	RESISTOR 2.2K 5% .25W FC TC=-400/+200	01121	CR2225
A3R21	0683-2225	3		RESISTOR 2.2K 5% .25W FC TC=-400/+200	01121	CR2225
A3R22	0683-1055	5	1	RESISTOR 1M 5% .25W FC TC=-400/+900	01121	CR1055
A3R23	0699-0277	0	2	RESISTOR 10K .02 .1W F TC=0+-15	20480	0699-0277
A3R24	0699-0277	4	1	RESISTOR 10K .025% .1W F TC=0+-15	20480	0699-0277
A3R25	0683-4725	2		RESISTOR 4.7K 5% .25W FC TC=-400/+200	01121	CR4725
A3R26	0698-0474	7	1	RESISTOR 800 .1% .1W F TC=0+-5	20480	0698-0474
A3R27	0699-0287	6	3	RESISTOR 100 .1% .1W F TC=0+-15	20480	0699-0287
A3R28	0699-0287	6	3	RESISTOR 100 .1% .1W F TC=0+-15	20480	0699-0287
A3R29	0698-3628	3	2	RESISTOR 220 5% 2W MO TC=0+-200	20480	0698-3628
A3R30	0698-3628	3	2	RESISTOR 220 5% 2W MO TC=0+-200	20480	0698-3628
A3R31	0699-0057	8		RESISTOR 2K .1% .1W F TC=0+-5	20480	0699-0057
A3R32	0698-2207	2	1	RESISTOR-FXD 900 0HM 0.05% 1/8W MF	20480	0698-2207
A3R33	0699-0287	6	6	RESISTOR 100 .1% .1W F TC=0+-15	20480	0699-0287
A3R34	0698-3150	6	2	RESISTOR 2.32K 1% .125W F TC=0+-100	24546	C4-1/8-10-2321-F
A3R35	0698-0885	0	2	RESISTOR 2.61K 1% .125W F TC=0+-100	24546	C4-1/8-10-2611-F

See introduction to this section for ordering information.
*Indicates factory selected value

Table 6-3. Replaceable Parts

Reference Designation	HP Part Number	C D	Qty	Description	Mfr Code	Mfr Part Number
A3R36	0698-0085	0		RESISTOR 2.61K 1% .125W F TC=0+-100	24546	C4-1/8-T0-2611-F
A3R37	0698-3150	6		RESISTOR 2.37K 1% .125W F TC=0+-100	24546	C4-1/8-T0-2371-F
A3R38	1810-0205	7	1	NETWORK-RES B SIP4.7K OHM X 7	01121	208A472
A3R39	0683-1825	7	1	RESISTOR 1.8K 5% .25W FC TC=-400/+700	01121	CR1825
A3R40*	0757-0464			90.9K 1%		
A3T1	04193-61501	0	1	BALUN	28480	04193-61501
A3U1	1826-0712	4	1	IC OP AMP LOW-BIAS-H-IMPD DUAL 8-DIP-P	27014	LF353N
A3U2	1826-0319	7	2	IC OP AMP LOW-BIAS-H-IMPD TO-99 PKG	04713	LF356G
A3U3	1820-1958	0	3	IC SWITCH ANLG QUAD 14-DIP-P PKG	0192B	CD4016BE
A3U4	1820-1958	0		IC SWITCH ANLG QUAD 14-DIP-P PKG	0192B	CD4016BE
A3U5	1826-0319	7		IC OP AMP LOW-BIAS-H-IMPD TO-99 PKG	04713	LF356G
A3U6	1820-1958	0		IC SWITCH ANLG QUAD 14-DIP-P PKG	0192B	CD4016BE
A3U7	1826-0138	8	1	IC COMPARTOR GP QUAD 14-DIP-P PKG	01295	LM339N
A3U8	1820-1745	3	1	IC GATE CMOS NOR QUAD 2-INP	04713	MC14001BCP
	04193-60003	5	1	COVER	28480	04193-60003
	04193-26503	0	1	PCBD BLANK	28480	04193-26503

See introduction to this section for ordering information
 *Indicates factory selected value

Table 6-3. Replaceable Parts

Reference Designation	HP Part Number	C D	Qty	Description	Mfr Code	Mfr Part Number
A4						
A4	04193-66504	3	1	I CHANNEL AMPLIFIER BOARD ASSEMBLY	20400	04193-66504
A4C1	0160-0570	2	2	CAPACITOR-FXD 220PF +-20% 100VDC CER	20400	0160-0570
A4C2	0160-3877	5	2	CAPACITOR-FXD 100PF +-20% 100VDC CER	20400	0160-3877
A4C3	0160-0570	2	2	CAPACITOR-FXD 220PF +-20% 100VDC CER	20400	0160-0570
A4C4	0160-3877	5	2	CAPACITOR-FXD 100PF +-20% 100VDC CER	20400	0160-3877
A4C5	0160-3878	6	1	CAPACITOR-FXD 1000PF +-20% 100VDC CER	20400	0160-3878
A4C6	0160-4835	7	8	CAPACITOR-FXD .10UF +-10% 50VDC CER	20400	0160-4835
A4C7	0160-0127	2	3	CAPACITOR-FXD .10UF +-20% 25VDC CER	20400	0160-0127
A4C9	0160-0127	2	2	CAPACITOR-FXD .10UF +-20% 25VDC CER	20400	0160-0127
A4C9	0160-4306	3	1	CAPACITOR-FXD 33PF +-5% 200VDC CER 0+-30	51642	200-200-NP 0-330J
A4C10	0160-4832	4	1	CAPACITOR-FXD .010UF +-10% 100VDC CER	20400	0160-4832
A4C11	0180-1083	3	5	CAPACITOR-FXD 330UF 25VDC AL	20400	0180-1083
A4C12	0180-1083	3	5	CAPACITOR-FXD 330UF 25VDC AL	20400	0180-1083
A4C13	0160-0127	2	2	CAPACITOR-FXD .10UF +-20% 25VDC CER	20400	0160-0127
A4C14	0160-4835	7	2	CAPACITOR-FXD .10UF +-10% 50VDC CER	20400	0160-4835
A4C15	0160-4835	7	2	CAPACITOR-FXD .10UF +-10% 50VDC CER	20400	0160-4835
A4C16	0180-0291	3	1	CAPACITOR-FXD .10UF +-10% 35VDC TA	56289	150D105X9035A2
A4C17	0180-0374	3	1	CAPACITOR-FXD .10UF +-10% 20VDC TA	56289	150D106X9020B2
A4C18	0180-0116	1	1	CAPACITOR-FXD 6.8UF+-10% 35VDC TA	56289	150D68X9035B2
A4C19	0160-2206	2	1	CAPACITOR-FXD 160PF +-5% 300VDC MICA	20400	0160-2206
A4C20	0160-1083	3	3	CAPACITOR-FXD 330UF 25VDC AL	20400	0180-1083
A4C21	0180-1083	3	3	CAPACITOR-FXD 330UF 25VDC AL	20400	0180-1083
A4C22	0180-1083	3	3	CAPACITOR-FXD 330UF 25VDC AL	20400	0180-1083
A4C23	0160-4835	7	2	CAPACITOR-FXD .10UF +-10% 50VDC CER	20400	0160-4835
A4C24	0160-4835	7	2	CAPACITOR-FXD .10UF +-10% 50VDC CER	20400	0160-4835
A4C25	0160-4835	7	2	CAPACITOR-FXD .10UF +-10% 50VDC CER	20400	0160-4835
A4C26	0160-4835	7	2	CAPACITOR-FXD .10UF +-10% 50VDC CER	20400	0160-4835
A4C27	0160-4835	7	2	CAPACITOR-FXD .10UF +-10% 50VDC CER	20400	0160-4835
A4CR1	1901-0179	7	1	DIODE-SWITCHING 15V 50MA 750PS D0-7	20400	1901-0179
A4J1	1251-5862	6	2	CONNECTOR 4 PIN M METRIC POST TYPE	20400	1251-5862
A4J2	1251-5862	6	2	CONNECTOR 4 PIN M METRIC POST TYPE	20400	1251-5862
A4L1	9140-0114	4	4	INDUCTOR RF-CH-MLD 100H 10% .166DX.385LG	20400	9140-0114
A4L2	9140-0114	4	4	INDUCTOR RF-CH-MLD 100H 10% .166DX.385LG	20400	9140-0114
A4L3	9140-0114	4	4	INDUCTOR RF-CH-MLD 100H 10% .166DX.385LG	20400	9140-0114
A4L4	9140-0114	4	4	INDUCTOR RF-CH-MLD 100H 10% .166DX.385LG	20400	9140-0114
A4Q1	1054-0129	6	1	TRANSISTOR-NPN 2SC1636	20400	1054-0129
A4R1	0698-3155	2	5	RESISTOR 4.7K 1% .25W FC TC=-400/+600	01121	
A4R2	0698-7205	4	4	RESISTOR 51 .25W FC TC=-400/+500	01121	
A4R3	0683-4725	0	1	RESISTOR 470 5% .25W FC TC=-400/+600	01121	CB4725
A4R4	0698-7205	4	4	RESISTOR 51 .25W FC TC=-400/+500	01121	
A4R5	0698-3155	2	2	RESISTOR 4.7K .25W FC TC=-400/+600	01121	
A4R6	2100-3103	1	1	RESISTOR-TRMR 10K 10% C SIDE-ADJ 1-TRN	20400	2100-3103
A4R7	0683-5105	4	4	RESISTOR 51 5% .25W FC TC=-400/+500	01121	CB5105
A4R8	0683-1025	9	1	RESISTOR 1K 5% .25W FC TC=-400/+600	01121	CB1025
A4R9	0683-5105	4	4	RESISTOR 51 5% .25W FC TC=-400/+500	01121	CB5105
A4R10	2100-3352	7	1	RESISTOR-TRMR 1K 10% C SIDE-ADJ 1-TRN	20400	2100-3352
A4R11	0698-4158	6	2	RESISTOR 100K .1% .125W F TC=0+-50	20400	0698-4158
A4R12	0698-4158	6	2	RESISTOR 100K .1% .125W F TC=0+-50	20400	0698-4158
A4R13	0683-4725	2	3	RESISTOR 4.7K 5% .25W FC TC=-400/+700	01121	CB4725
A4R14	0683-4725	2	2	RESISTOR 4.7K 5% .25W FC TC=-400/+700	01121	CB4725
A4R15	0683-2225	3	2	RESISTOR 2.2K 5% .25W FC TC=-400/+700	01121	CB2225
A4R16	0683-2225	3	2	RESISTOR 2.2K 5% .25W FC TC=-400/+700	01121	CB2225
A4R17	0683-1055	5	1	RESISTOR 10 5% .25W FC TC=-300/+900	01121	CB1055
A4R18	0698-3152	8	1	RESISTOR 3.48K 1% .125W F TC=0+-100	24546	C4-1/8-T0-3481-F
A4R19	0757-0421	4	1	RESISTOR 025 1% .125W F TC=0+-100	24546	C4-1/8-T0-025R-F
A4R20	0757-0465	6	1	RESISTOR 100K 1% .125W F TC=0+-100	24546	C4-1/8-T0-1003-F
A4R21	0757-0317	7	1	RESISTOR 1.33K 1% .125W F TC=0+-100	24546	C4-1/8-T0-1331-F
A4R22	0698-3153	9	1	RESISTOR 3.83K 1% .125W F TC=0+-100	24546	C4-1/8-T0-3831-F
A4R23	0698-8474	7	1	RESISTOR 800 .1% .1W F TC=0+-5	20400	0698-8474
A4R24	0699-0287	6	2	RESISTOR 100 .1% .1W F TC=0+-15	20400	0699-0287
A4R25	0699-0287	6	2	RESISTOR 100 .1% .1W F TC=0+-15	20400	0699-0287
A4R26	0698-2199	1	1	RESISTOR MET FILM 40K OHM 0.1% 1/8W	20400	0698-2199
A4R27 *	0757-0482	7	2	RESISTOR 511K 1% .125W F TC=0+-100	20400	0757-0482
A4R28	0698-6414	1	1	RESISTOR 1K .1% .1W F TC=0+-5	20400	0698-6414
A4R29	0683-4725	2	1	RESISTOR 4.7K 5% .25W FC TC=-400/+700	01121	CB4725
A4R30	2100-3252	6	1	RESISTOR-TRMR 5K 10% C TOP ADJ 1-TRN	20400	2100-3252
A4R31	0757-0442	9	4	RESISTOR 10K 1% .125W F TC=0+-100	24546	C4-1/8-T0-1002-F
A4R32	0757-0442	9	4	RESISTOR 10K 1% .125W F TC=0+-100	24546	C4-1/8-T0-1002-F
A4R33	0757-0442	9	4	RESISTOR 10K 1% .125W F TC=0+-100	24546	C4-1/8-T0-1002-F
A4R34	0757-0482	7	2	RESISTOR 511K 1% .125W F TC=0+-100	20400	0757-0482
A4R35	0757-0442	9	4	RESISTOR 10K 1% .125W F TC=0+-100	24546	C4-1/8-T0-1002-F

See introduction to this section for ordering information
 *Indicates factory selected value

Table 6-3. Replaceable Parts

Reference Designation	HP Part Number	C D	Qty	Description	Mfr Code	Mfr Part Number
A4R36	0757-0401	0	1	RESISTOR 100 1% .125W F TC=0+-100	24546	C4 1/8-10-101 F
A4R37	1810-0205	7	1	NETWORK-RES 8-SIP4.7K OHM X 7	01121	208A472
A4R38	0683-1825	7	1	RESISTOR 1.0K 5% .25W FC TC= 400/+700	01121	CR1825
A4T1	04193-61501	0	1	BALUN	28480	04193-61501
A4U1	1826-0271	0	1	IC OP AMP GP 8-DIP-P PKG	01295	SN22741P
A4U2	1826-0081	0	1	IC OP AMP WR TO-99 PKG	27014	LM318H
A4U3	1826-0712	4	1	IC OP AMP LOW-BIAS-H-IMPD DUAL 8-DIP-P	27014	LF353N
A4U4	1820-1958	0	1	IC SWITCH ANLG QUAD 14-DIP-P PKG	01228	CP4016BT
A4U5	1826-0319	7	1	IC OP AMP LOW-BIAS-H-IMPD TO-99 PKG	04713	LF356C
A4U6	1826-0138	8	1	IC COMPARATOR GP QUAD 14-DIP-P PKG	01295	LM339N
	5001-0176	7	1	STRAP-GROUND	28480	5001-0173
	04193-60004	6	1	COVER	28480	04193-60004
	04193-26504	0	1	PCBD BLANK	28480	04193-26504

See introduction to this section for ordering information
 *Indicates factory selected value

Table 6-3. Replaceable Parts

Reference Designation	HP Part Number	C D	Qty	Description	Mfr Code	Mfr Part Number
A5						
A5	04193-66505	4	1	MIXER & DIVIDER BOARD ASSEMBLY	28480	04193-66505
A5C1	0160-2437	1	2	CAPACITOR-FDTHRU 5000PF +80 -20% 200V	28480	0160-2437
A5C2	0160-2437	1		CAPACITOR-FDTHRU 5000PF +80 -20% 200V	28480	0160-2437
A5C3	0180-0228	6	3	CAPACITOR-FXD 22UF+-10% 50VDC TA	56289	150D226X9015B2
A5C4	0160-4835	7	9	CAPACITOR-FXD .1UF +-10% 50VDC CER	28480	0160-4835
A5C5	0160-4835	7		CAPACITOR-FXD .1UF +-10% 50VDC CER	28480	0160-4835
A5C6	0160-4835	7		CAPACITOR-FXD .1UF +-10% 50VDC CER	28480	0160-4835
A5C7	0160-4386	3	4	CAPACITOR-FXD 33PF +-5% 200VDC CER 0+-30	51642	200-200-NP0-330J
A5C8	0160-4801	7	1	CAPACITOR-FXD 100PF +-5% 100VDC CER	28480	0160-4801
A5C9	0180-0228	6		CAPACITOR-FXD 22UF+-10% 50VDC TA	56289	150D226X9015B2
A5C10	0160-4835	7		CAPACITOR-FXD .1UF +-10% 50VDC CER	28480	0160-4835
A5C11	0160-4386	3		CAPACITOR-FXD 33PF +-5% 200VDC CER 0+-30	51642	200-200-NP0-330J
A5C12	0160-4386	3		CAPACITOR-FXD 33PF +-5% 200VDC CER 0+-30	51642	200-200-NP0-330J
A5C13	0160-4386	3		CAPACITOR-FXD 33PF +-5% 200VDC CER 0+-30	51642	200-200-NP0-330J
A5C14	0160-4835	7		CAPACITOR-FXD .1UF +-10% 50VDC CER	28480	0160-4835
A5C15	0160-4832	4	4	CAPACITOR-FXD .01UF +-10% 100VDC CER	28480	0160-4832
A5C16	0160-4832	4		CAPACITOR-FXD .01UF +-10% 100VDC CER	28480	0160-4832
A5C17	0160-4835	7		CAPACITOR-FXD .1UF +-10% 50VDC CER	28480	0160-4835
A5C18	0180-0228	6		CAPACITOR-FXD 22UF+-10% 50VDC TA	56289	150D226X9015B2
A5C19	0180-0374	3	1	CAPACITOR-FXD 100PF +-10% 20VDC TA	56289	150D106X9020B2
A5C20	0160-4835	7		CAPACITOR-FXD .1UF +-10% 50VDC CER	28480	0160-4835
A5C21	0160-4832	4		CAPACITOR-FXD .01UF +-10% 100VDC CER	28480	0160-4832
A5C22	0160-4832	4		CAPACITOR-FXD .01UF +-10% 100VDC CER	28480	0160-4832
A5C23	0160-4574	1	8	CAPACITOR-FXD 1000PF +-10% 100VDC CER	28480	0160-4574
A5C24	0160-4574	1		CAPACITOR-FXD 1000PF +-10% 100VDC CER	28480	0160-4574
A5C25	0160-4574	1		CAPACITOR-FXD 1000PF +-10% 100VDC CER	28480	0160-4574
A5C26	0160-4835	7		CAPACITOR-FXD .1UF +-10% 50VDC CER	28480	0160-4835
A5C27	0160-4574	1		CAPACITOR-FXD 1000PF +-10% 100VDC CER	28480	0160-4574
A5C28	0160-4574	1		CAPACITOR-FXD 1000PF +-10% 100VDC CER	28480	0160-4574
A5C29	0180-1083	3	1	CAPACITOR-FXD 33UF 25VDC AL	28480	0180-1083
A5C30	0160-4835	7		CAPACITOR-FXD .1UF +-10% 50VDC CER	28480	0160-4835
A5C31	0160-4574	1		CAPACITOR-FXD 1000PF +-10% 100VDC CER	28480	0160-4574
A5C32	0160-4574	1		CAPACITOR-FXD 1000PF +-10% 100VDC CER	28480	0160-4574
A5C33	0160-4574	1		CAPACITOR-FXD 1000PF +-10% 100VDC CER	28480	0160-4574
A5CR1	1901-0040	1	1	DIODE-SWITCHING 30V 50MA 2NS DO-35	28480	1901-0040
A5E1	1906-0235	6	1	DIODE-DOUBLE BALANCED MIXER	28480	1906-0235
A5L1	9100-2817	4	2	INDUCTOR RF-CO-MLD 100NH 5% .105DX.26LG	28480	9100-2817
A5L2	9100-2251	0	1	INDUCTOR RF-CO-MLD 220NH 10% .105DX.26LG	28480	9100-2251
A5L3	9100-2249	6	2	INDUCTOR RF-CO-MLD 150NH 10% .105DX.26LG	28480	9100-2249
A5L4	9100-2817	4		INDUCTOR RF-CO-MLD 100NH 5% .105DX.26LG	28480	9100-2817
A5L5	9100-2249	6		INDUCTOR RF-CO-MLD 150NH 10% .105DX.26LG	28480	9100-2249
A5Q1	1854-0247	9	1	TRANSISTOR NPN SI T0-39 PD=1W FT=000MHZ	28480	1854-0247
A5Q2	1854-0345	8	2	TRANSISTOR NPN 2N5179 SI T0-72 PD=200MW	04713	2N5179
A5Q3	1854-0345	8		TRANSISTOR NPN 2N5179 SI T0-72 PD=200MW	04713	2N5179
A5R1	0683-4715	0	3	RESISTOR 470 5% .25W FC TC=-400/+600	01121	CR4715
A5R2	0683-4715	0		RESISTOR 470 5% .25W FC TC=-400/+600	01121	CR4715
A5R3	0683-4715	0		RESISTOR 470 5% .25W FC TC=-400/+600	01121	CR4715
A5R4	0683-1005	5	1	RESISTOR 10 5% .25W FC TC=-400/+500	01121	CR1005
A5R5	0757-0279	0	8	RESISTOR 3.16K 1% .125W F TC=0+-100	24546	C4-1/8-T0-3161-F
A5R6	0698-0084	9	0	RESISTOR 2.15K 1% .125W F TC=0+-100	24546	C4-1/8-T0-2151-F
A5R7	0757-0279	0		RESISTOR 3.16K 1% .125W F TC=0+-100	24546	C4-1/8-T0-3161-F
A5R8	0698-0084	9		RESISTOR 2.15K 1% .125W F TC=0+-100	24546	C4-1/8-T0-2151-F
A5R9	0757-0279	0		RESISTOR 3.16K 1% .125W F TC=0+-100	24546	C4-1/8-T0-3161-F
A5R10	0698-0084	9		RESISTOR 2.15K 1% .125W F TC=0+-100	24546	C4-1/8-T0-2151-F
A5R11	0698-3441	8	1	RESISTOR 215 1% .125W F TC=0+-100	24546	C4-1/8-T0-215R-F
A5R12	0757-0394	0	1	RESISTOR 51.1 1% .125W F TC=0+-100	24546	C4-1/8-T0-51R1-F
A5R13	0698-3440	7	1	RESISTOR 196 1% .125W F TC=0+-100	24546	C4-1/8-T0-196R-F
A5R14	0757-0401	0	1	RESISTOR 100 1% .125W F TC=0+-100	24546	C4-1/8-T0-101 F
A5R15	0683-2705	4	1	RESISTOR 27 5% .25W FC TC=-400/+500	01121	CR2705
A5R16	0683-6005	3	1	RESISTOR 60 5% .25W FC TC=-400/+500	01121	CR6005
A5R17	0698-0085	0	1	RESISTOR 2.61K 1% .125W F TC=0+-100	24546	C4-1/8-T0-2611-F
A5R18	0683-1815	5	2	RESISTOR 180 5% .25W FC TC=-400/+600	01121	CR1815
A5R19	0698-0082	7	1	RESISTOR 464 1% .125W F TC=0+-100	24546	C4-1/8-T0-4640-F
A5R20	0683-1815	5		RESISTOR 180 5% .25W FC TC=-400/+600	01121	CR1815
A5R21	0698-0084	9		RESISTOR 2.15K 1% .125W F TC=0+-100	24546	C4-1/8-T0-2151-F
A5R22	0757-0279	0		RESISTOR 3.16K 1% .125W F TC=0+-100	24546	C4-1/8-T0-3161-F
A5R23	0683-4725	2	1	RESISTOR 4.7K 5% .25W FC TC=-400/+700	01121	CR4725
A5R24	0698-0084	9		RESISTOR 2.15K 1% .125W F TC=0+-100	24546	C4-1/8-T0-2151-F
A5R25	0757-0279	0		RESISTOR 3.16K 1% .125W F TC=0+-100	24546	C4-1/8-T0-3161-F

See introduction to this section for ordering information
 *Indicates factory selected value

Table 6-3. Replaceable Parts

Reference Designation	HP Part Number	C D	Qty	Description	Mfr Code	Mfr Part Number
ASR26	0683-5615	1	17	RESISTOR 560 5% .25W FC TC=-400/+600	01121	CB5615
ASR27	0683-5615	1		RESISTOR 560 5% .25W FC TC=-400/+600	01121	CB5615
ASR28	0683-5615	1		RESISTOR 560 5% .25W FC TC=-400/+600	01121	CB5615
ASR29	0683-5615	1		RESISTOR 560 5% .25W FC TC=-400/+600	01121	CB5615
ASR30	0683-5615	1		RESISTOR 560 5% .25W FC TC=-400/+600	01121	CB5615
ASR31	0683-5615	1		RESISTOR 560 5% .25W FC TC=-400/+600	01121	CB5615
ASR32	0683-5615	1		RESISTOR 560 5% .25W FC TC=-400/+600	01121	CB5615
ASR33	0683-5615	1		RESISTOR 560 5% .25W FC TC=-400/+600	01121	CB5615
ASR34	0683-5615	1		RESISTOR 560 5% .25W FC TC=-400/+600	01121	CB5615
ASR35	0698-0004	9		RESISTOR 2.15K 1% .125W F TC=0+/-100	24546	C4-1/8-T0-2151-F
ASR36	0757-0279	0		RESISTOR 3.16K 1% .125W F TC=0+/-100	24546	C4-1/8-T0-3161-F
ASR37	0698-0004	9		RESISTOR 2.15K 1% .125W F TC=0+/-100	24546	C4-1/8-T0-2151-F
ASR38	0757-0279	0		RESISTOR 3.16K 1% .125W F TC=0+/-100	24546	C4-1/8-T0-3161-F
ASR39	0698-0004	9		RESISTOR 2.15K 1% .125W F TC=0+/-100	24546	C4-1/8-T0-2151-F
ASR40	0757-0279	0		RESISTOR 3.16K 1% .125W F TC=0+/-100	24546	C4-1/8-T0-3161-F
ASR41	0683-2215	1	1	RESISTOR 220 5% .25W FC TC=-400/+600	01121	CB2215
ASR42	0683-3315	4	1	RESISTOR 330 5% .25W FC TC=-400/+600	01121	CB3315
ASR43	0683-5615	1		RESISTOR 560 5% .25W FC TC=-400/+600	01121	CB5615
ASR44	0683-5615	1		RESISTOR 560 5% .25W FC TC=-400/+600	01121	CB5615
ASR45	0683-5615	1		RESISTOR 560 5% .25W FC TC=-400/+600	01121	CB5615
ASR46	0683-5615	1		RESISTOR 560 5% .25W FC TC=-400/+600	01121	CB5615
ASR47	0683-5615	1		RESISTOR 560 5% .25W FC TC=-400/+600	01121	CB5615
ASR48	0683-5615	1		RESISTOR 560 5% .25W FC TC=-400/+600	01121	CB5615
ASR49	0683-5615	1		RESISTOR 560 5% .25W FC TC=-400/+600	01121	CB5615
ASR50	0683-5615	1		RESISTOR 560 5% .25W FC TC=-400/+600	01121	CB5615
ASU1	1820-1200	5	1	IC INV TTL LS HEX	01295	SN74LS05N
ASU2	1820-0817	8	2	IC FF ECL D-M/S DUAL	04713	MC10131P
ASU3	1820-1198	0	1	IC GATE TTL LS NAND QUAD 2-INP	01295	SN74LS03N
ASU4	1820-1224	3	1	IC RCVR ECL LINE RCVR TPL 2-INP	04713	MC10216P
ASU5	1820-0817	8		IC FF ECL D-M/S DUAL	04713	MC10131P
ASU6	1820-0804	3	1	IC GATE ECL NOR TPL	04713	MC10106P
ASU7	1820-0821	4	1	IC CNTR ECL BIN UP/DOWN SYNCHRD	04713	MC10136L
	1205-0011	0	1	HEAT SINK T0-5/T0-39-CS	28480	1205-0011
	5001-0173	7	2	STRAP-GROUND	28480	5001-0173
	04193-60005	7	1	COVER	28480	04193-60005
	04193-26505	0	1	PCBD BLANK	28480	04193-26505

See introduction to this section for ordering information
 *Indicates factory selected value

Table 6-3. Replaceable Parts

Reference Designation	HP Part Number	C D	Qty	Description	Mfr Code	Mfr Part Number
A6						
A6	04193-66506	5	1	UCXD BOARD ASSEMBLY	28480	04193-66506
A6C1	0160-2437	1	3	CAPACITOR-FDTHRU 5000PF +80 -20% 200V	28480	0160-2437
A6C2	0160-2437	1		CAPACITOR-FDTHRU 5000PF +80 -20% 200V	28480	0160-2437
A6C3	0160-2437	1		CAPACITOR-FDTHRU 5000PF +80 -20% 200V	28480	0160-2437
A6C4	0160-5495	3	5	CAPACITOR-FXD 3.9PF +-1.5PF 200VDC CER		
A6C5	0160-5620	2	3	CAPACITOR-FXD 15PF +-5% 200VDC CER 0+-30	51642	200-200-NP6-156J
A6C6	0160-5495	3		CAPACITOR-FXD 3.9PF +-1.5PF 200VDC CER		
A6C7	0121-0453	5	2	CAPACITOR-V TRMR-AIR 1.3-5.4PF 175V	74970	187-0303-125
A6C8	0121-0453	5		CAPACITOR-V TRMR-AIR 1.3-5.4PF 175V	74970	187-0303-125
A6C9	0160-5617	3		CAPACITOR-FXD 3PF +-1.5PF 200VDC CER		
A6C10	0160-4103	2	2	CAPACITOR-FXD 220PF +-5% 100VDC CER	72982	0121-M100 C06-221J
A6C11	0160-4103	2		CAPACITOR-FXD 220PF +-5% 100VDC CER	72982	0121-M100 C06-221J
A6C12	0160-4832	2	2	CAPACITOR-FXD 1000PF +-5% 100VDC CER	28480	0160-4832
A6C13	0160-4832	4	8	CAPACITOR-FXD .01UF +-10% 100VDC CER	28480	0160-4832
A6C14	0160-4832	4		CAPACITOR-FXD .01UF +-10% 100VDC CER	28480	0160-4832
A6C15	0160-3872	0	1	CAPACITOR-FXD 2.2PF +-1.25PF 200VDC CER	28480	0160-3872
A6C16	0160-3879	7	8	CAPACITOR-FXD .01UF +-20% 100VDC CER	28480	0160-3879
A6C17	0160-3879	7		CAPACITOR-FXD .01UF +-20% 100VDC CER	28480	0160-3879
A6C18	0160-3879	7		CAPACITOR-FXD .01UF +-20% 100VDC CER	28480	0160-3879
A6C19	0160-3879	7		CAPACITOR-FXD .01UF +-20% 100VDC CER	28480	0160-3879
A6C20	0160-3879	7		CAPACITOR-FXD .01UF +-20% 100VDC CER	28480	0160-3879
A6C21	0160-4835	7	10	CAPACITOR-FXD .1UF +-10% 50VDC CER	28480	0160-4835
A6C22	0160-4832	4		CAPACITOR-FXD .01UF +-10% 100VDC CER	28480	0160-4832
A6C23	0160-4832	4		CAPACITOR-FXD .01UF +-10% 100VDC CER	28480	0160-4832
A6C24	0160-4832	4		CAPACITOR-FXD .01UF +-10% 100VDC CER	28480	0160-4832
A6C25	0160-4835	7		CAPACITOR-FXD .1UF +-10% 50VDC CER	28480	0160-4835
A6C26	0160-5620	2		CAPACITOR-FXD 15PF +-5% 200VDC CER 0+-30	51642	200-200-NP6-156J
A6C27	0160-5621	3	1	CAPACITOR-FXD 22PF +-5% 200VDC CER 0+-30	28480	0160-5625
A6C28	0160-3879	7		CAPACITOR-FXD .01UF +-20% 100VDC CER	28480	0160-3879
A6C29	0160-3879	7		CAPACITOR-FXD .01UF +-20% 100VDC CER	28480	0160-3879
A6C30	0160-4832	2		CAPACITOR-FXD 1000PF +-5% 100VDC CER	28480	0160-4832
A6C31	0160-4832	4		CAPACITOR-FXD .01UF +-10% 100VDC CER	28480	0160-4832
A6C32	0180-0374	3	1	CAPACITOR-FXD 10UF+-10% 20VDC TA	56289	150D106X9020B2
A6C33	0160-5620	2		CAPACITOR-FXD 15PF +-5% 200VDC CER 0+-30	51642	200-200-NP0-150J
A6C34	0160-5495	3		CAPACITOR-FXD 3.9PF +-1.5PF 200VDC CER	51642	200-200-NP0-399D
A6C35	0160-5495	3		CAPACITOR-FXD 3.9PF +-1.5PF 200VDC CER	51642	200-200-NP0-399D
A6C36	0160-3879	7		CAPACITOR-FXD .01UF +-20% 100VDC CER	28480	0160-3879
A6C37	0160-3877	5	1	CAPACITOR-FXD 100PF +-20% 200VDC CER	28480	0160-3877
A6C38	0160-4801	7	1	CAPACITOR-FXD 100PF +-5% 100VDC CER	28480	0160-4801
A6C39	0160-4832	4		CAPACITOR-FXD .01UF +-10% 100VDC CER	28480	0160-4832
A6C40	0160-4832	4		CAPACITOR-FXD .01UF +-10% 100VDC CER	28480	0160-4832
A6C41	0160-4835	4		CAPACITOR-FXD .1UF +-10% 50VDC CER	28480	0160-4835
A6C42	0160-0161	4	2	CAPACITOR-FXD .01UF +-10% 200VDC POLYE	28480	0160-0161
A6C43	0160-2201	7	1	CAPACITOR-FXD 51PF +-5% 300VDC MICA	28480	0160-2201
A6C44	0180-1083	3	6	CAPACITOR-FXD 330F 25VDC AL	28480	0180-1083
A6C45	0160-4835	7		CAPACITOR-FXD .1UF +-10% 50VDC CER	28480	0160-4835
A6C46	0160-4835	7		CAPACITOR-FXD .1UF +-10% 50VDC CER	28480	0160-4835
A6C47	0160-2204	0	1	CAPACITOR-FXD 100PF +-5% 300VDC MICA	28480	0160-2204
A6C48	0180-0197	8	2	CAPACITOR-FXD 2.2UF +-10% 28VDC TA	56289	150D225X9020A2
A6C49	0180-0197	8		CAPACITOR-FXD 2.2UF +-10% 28VDC TA	56289	150D225X9020A2
A6C50	0160-4835	7		CAPACITOR-FXD .1UF +-10% 50VDC CER	28480	0160-4835
A6C51	0180-1083	3		CAPACITOR-FXD 330F 25VDC AL	28480	0180-1083
A6C52	0180-1083	3		CAPACITOR-FXD 330F 25VDC AL	28480	0180-1083
A6C53	0160-4835	7		CAPACITOR-FXD .1UF +-10% 50VDC CER	28480	0160-4835
A6C54	0160-4835	7		CAPACITOR-FXD .1UF +-10% 50VDC CER	28480	0160-4835
A6C55	0160-4835	7		CAPACITOR-FXD .1UF +-10% 50VDC CER	28480	0160-4835
A6C56	0160-0362	7	1	CAPACITOR-FXD 510PF +-5% 300VDC MICA	28480	0160-0362
A6C57	0160-0161	4		CAPACITOR-FXD .01UF +-10% 200VDC POLYE	28480	0160-0161
A6C58	0160-0127	2	2	CAPACITOR-FXD 1UF +-20% 25VDC CER	28480	0160-0127
A6C59	0180-1083	3		CAPACITOR-FXD 330F 25VDC AL	28480	0180-1083
A6C60	0180-1083	3		CAPACITOR-FXD 330F 25VDC AL	28480	0180-1083
A6C61	0160-4835	7		CAPACITOR-FXD .1UF +-10% 50VDC CER	28480	0160-4835
A6C62	0180-1083	3		CAPACITOR-FXD 330F 25VDC AL	28480	0180-1083
A6C63	0160-0127	2		CAPACITOR-FXD 1UF +-20% 25VDC CER	28480	0160-0127
A6E1	1906-0235	6	1	DIODE-DOUBLE BALANCED MIXER	28480	1906-0235
A6CR1	0122-0072	6	1	DIODE-VVC 2.2PF 5% C3/C25 RIN=4.5	04713	001050
A6CR2	1901-0040	1	5	DIODE-SWITCHING 30V 50MA 2NS DO-35	28480	1901-0040
A6CR3	1901-0040	1		DIODE-SWITCHING 30V 50MA 2NS DO-35	28480	1901-0040
A6CR4	1901-0040	1		DIODE-SWITCHING 30V 50MA 2NS DO-35	28480	1901-0040
A6CR5	1901-0040	1		DIODE-SWITCHING 30V 50MA 2NS DO-35	28480	1901-0040
A6CR6	1901-0040	1		DIODE-SWITCHING 30V 50MA 2NS DO-35	28480	1901-0040
A6CR7	1902-0206	4	1	DIODE-ZNR 1N937 9V 5% DO 7 PD=.5W	24046	1N937
A6CR8	1902-3636	3	4	DIODE-ZNR 3.16V 5% DO 7 PD=.4W TC=-.064%	28480	1902-3636
A6CR9	1902-3097	6	1	DIODE-ZNR 5.25V 2% DO-35 PD=.4W	28480	1902-3097

See introduction to this section for ordering information
 *Indicates factory selected value

Table 6-3. Replaceable Parts

Reference Designation	HP Part Number	C D	Qty	Description	Mfr Code	Mfr Part Number
A6CR10	1902-3149	9	1	DIODE-ZNR 9.09V 5% DO-35 PD=.4W	28480	1902-3149
A6CR11	1902-3036	3		DIODE-ZNR 3.16V 5% DO-7 PD=.4W TC=-.064%	28480	1902-3036
A6CR12	1902-3036	3		DIODE-ZNR 3.16V 5% DO-7 PD=.4W TC=-.064%	28480	1902-3036
A6CR13	1902-3036	3		DIODE-ZNR 3.16V 5% DO-7 PD=.4W TC=-.064%	28480	1902-3036
A6J1	1250-0257	1	1	CONNECTOR-RF SMB M PG 50-OHM	28480	1250-0257
A6J2	1251-4822	6	1	CONNECTOR 3-PIN M POST TYPE	28480	1251-4822
A6J3	1258-0141	8	1	JUMPER-REM	28480	1258-0141
A6L1	9100-2251	0	5	INDUCTOR RF-CH-MLD 220NH 10% .105DX.26LG	28480	9100-2251
A6L2	9100-2247	4	1	INDUCTOR RF-CH-MLD 100NH 10% .105DX.26LG	28480	9100-2247
A6L3	9100-2250	9	1	INDUCTOR RF-CH-MLD 100NH 10% .105DX.26LG	28480	9100-2250
A6L4	9100-2891	4	2	INDUCTOR RF-CH-MLD 50NH 10% .105DX.26LG	28480	9100-2891
A6L5	9100-2891	4	4	INDUCTOR RF-CH-MLD 50NH 10% .105DX.26LG	28480	9100-2891
A6L6	9140-0641	8	1	RF TRANSFORMER	28480	9140-0641
A6L7	9140-0141	7	1	INDUCTOR RF-CH-MLD 680NH 10% .105DX.26LG	28480	9140-0141
A6L8	9100-0358	6	1	INDUCTOR RF-CH-MLD 330NH 10% .105DX.26LG	28480	9100-0358
A6L9	9100-2249	6	3	INDUCTOR RF-CH-MLD 150NH 10% .105DX.26LG	28480	9100-2249
A6L10	9100-2251	8		INDUCTOR RF-CH-MLD 220NH 10% .105DX.26LG	28480	9100-2251
A6L11	9100-2251	0		INDUCTOR RF-CH-MLD 220NH 10% .105DX.26LG	28480	9100-2251
A6L12	9100-2249	6		INDUCTOR RF-CH-MLD 150NH 10% .105DX.26LG	28480	9100-2249
A6L13	9100-2248	5	2	INDUCTOR RF-CH-MLD 120NH 10% .105DX.26LG	28480	9100-2248
A6L14	9100-2251	0		INDUCTOR RF-CH-MLD 220NH 10% .105DX.26LG	28480	9100-2251
A6L15	9100-2251	0		INDUCTOR RF-CH-MLD 220NH 10% .105DX.26LG	28480	9100-2251
A6L16	9100-2248	5		INDUCTOR RF-CH-MLD 120NH 10% .105DX.26LG	28480	9100-2248
A6L17	9100-2249	6		INDUCTOR RF-CH-MLD 150NH 10% .105DX.26LG	28480	9100-2249
A6Q1	1854-0345	8	7	TRANSISTOR NPN 2N5179 SI TO-72 PD=200MW	04713	2N5179
A6Q2	1854-0345	8		TRANSISTOR NPN 2N5179 SI TO-72 PD=200MW	04713	2N5179
A6Q3	1854-0345	8		TRANSISTOR NPN 2N5179 SI TO-72 PD=200MW	04713	2N5179
A6Q4	1854-0345	8		TRANSISTOR NPN 2N5179 SI TO-72 PD=200MW	04713	2N5179
A6Q5	1854-0345	8		TRANSISTOR NPN 2N5179 SI TO-72 PD=200MW	04713	2N5179
A6Q6	1854-0345	8		TRANSISTOR NPN 2N5179 SI TO-72 PD=200MW	04713	2N5179
A6Q7	1854-0345	8		TRANSISTOR NPN 2N5179 SI TO-72 PD=200MW	04713	2N5179
A6R1	0683-1015	7	1	RESISTOR 100 5% .25W FC TC=-400/+500	01121	CR1015
A6R2	0683-6815	5	1	RESISTOR 680 5% .25W FC TC=-400/+600	01121	CR6815
A6R3	0683-2225	3	5	RESISTOR 2.2K 5% .25W FC TC=-400/+700	01121	CR2225
A6R4	0757-0439	4	3	RESISTOR 6.81K 1% .125W F TC=0+/-100	24546	C4-1/8-T0-6811-F
A6R5	0698-3155	1	2	RESISTOR 4.64K 1% .125W F TC=0+/-100	24546	C4-1/8-T0-4641-F
A6R6	0698-3132	4	1	RESISTOR 261 1% .125W F TC=0+/-100	24546	C4-1/8-T0-2610-F
A6R7	0698-3155	1	1	RESISTOR 4.64K 1% .125W F TC=0+/-100	24546	C4-1/8-T0-4641-F
A6R8	0757-0439	4	4	RESISTOR 6.81K 1% .125W F TC=0+/-100	24546	C4-1/8-T0-6811-F
A6R9	0757-0421	4	1	RESISTOR 825 1% .125W F TC=0+/-100	24546	C4-1/8-T0-825R-F
A6R10	0698-3444	1	1	RESISTOR 316 1% .125W F TC=0+/-100	24546	C4-1/8-T0-316R-F
A6R11	0757-0274	5	2	RESISTOR 1.21K 1% .125W F TC=0+/-100	24546	C4-1/8-T0-1211-F
A6R12	0757-0439	4	4	RESISTOR 6.81K 1% .125W F TC=0+/-100	24546	C4-1/8-T0-6811-F
A6R13	0683-6805	3	3	RESISTOR 68 5% .25W FC TC=-400/+500	01121	CR6805
A6R14	0757-0419	0	1	RESISTOR 681 1% .125W F TC=0+/-100	24546	C4-1/8-T0-681R-F
A6R15	0757-0428	1	1	RESISTOR 1.62K 1% .125W F TC=0+/-100	24546	C4-1/8-T0-1621-F
A6R16	0757-0290	5	1	RESISTOR 6.19K 1% .125W F TC=0+/-100	19701	MF4C1/8-T0-6191-F
A6R17	0683-6805	3		RESISTOR 68 5% .25W FC TC=-400/+500	01121	CR6805
A6R18	0683-4715	0	2	RESISTOR 470 5% .25W FC TC=-400/+600	01121	CR4715
A6R19	0698-3441	8	2	RESISTOR 215 1% .125W F TC=0+/-100	24546	C4-1/8-T0-215R-F
A6R20	0757-1094	9	1	RESISTOR 1.47K 1% .125W F TC=0+/-100	24546	C4-1/8-T0-1471-F
A6R21	0757-0200	7	2	RESISTOR 5.62K 1% .125W F TC=0+/-100	24546	C4-1/8-T0-5621-F
A6R22	0683-2205	9	1	RESISTOR 22 5% .25W FC TC=-400/+500	01121	CR2205
A6R23	0698-3441	8		RESISTOR 215 1% .125W F TC=0+/-100	24546	C4-1/8-T0-215R-F
A6R24	0757-0417	8	1	RESISTOR 562 1% .125W F TC=0+/-100	24546	C4-1/8-T0-562R-F
A6R25	0683-1045	3	2	RESISTOR 100K 5% .25W FC TC=-400/+800	01121	CR1045
A6R26	0757-0279	0	1	RESISTOR 3.16K 1% .125W F TC=0+/-100	24546	C4-1/8-T0-3161-F
A6R27	0683-5605	9	1	RESISTOR 56 5% .25W FC TC=-400/+500	01121	CR5605
A6R28	0683-6805	3		RESISTOR 68 5% .25W FC TC=-400/+500	01121	CR6805
A6R29	0683-4705	8	1	RESISTOR 47 5% .25W FC TC=-400/+500	01121	CR4705
A6R30	0683-3305	2	5	RESISTOR 33 5% .25W FC TC=-400/+500	01121	CR3305
A6R31	0683-3305	2		RESISTOR 33 5% .25W FC TC=-400/+500	01121	CR3305
A6R32	0683-4715	0		RESISTOR 470 5% .25W FC TC=-400/+600	01121	CR4715
A6R33	0683-2215	1	1	RESISTOR 220 5% .25W FC TC=-400/+600	01121	CR2215
A6R34	0757-0442	9	2	RESISTOR 10K 1% .125W F TC=0+/-100	24546	C4-1/8-T0-1002-F
A6R35	0698-3157	3	1	RESISTOR 19.6K 1% .125W F TC=0+/-100	24546	C4-1/8-T0-1962-F
A6R36	0683-3305	2		RESISTOR 33 5% .25W FC TC=-400/+500	01121	CR3305
A6R37	0683-2225	3		RESISTOR 2.2K 5% .25W FC TC=-400/+700	01121	CR2225
A6R38	0683-1045	3		RESISTOR 100K 5% .25W FC TC=-400/+800	01121	CR1045
A6R39	0683-4725	2	1	RESISTOR 4.7K 5% .25W FC TC=-400/+700	01121	CR4725
A6R40	0683-1025	7	2	RESISTOR 1.0K 5% .25W FC TC=-400/+700	01121	CR1025
A6R41	0683-1025	7		RESISTOR 1.0K 5% .25W FC TC=-400/+700	01121	CR1025
A6R42	0683-1225	1	1	RESISTOR 1.2K 5% .25W FC TC=-400/+700	01121	CR1225
A6R43	0683-2225	3		RESISTOR 2.2K 5% .25W FC TC=-400/+700	01121	CR2225
A6R44	0683-1235	3	1	RESISTOR 12K 5% .25W FC TC=-400/+800	01121	CR1235
A6R45	0683-6825	7	1	RESISTOR 6.8K 5% .25W FC TC=-400/+700	01121	CR6825

See introduction to this section for ordering information
 *Indicates factory selected value

Table 6-3. Replaceable Parts

Reference Designation	HP Part Number	C D	Qty	Description	Mfr Code	Mfr Part Number
A6R46	0757-0200	7		RESISTOR 5.62K 1% .125W F TC=0+-100	24546	C4-1/8-T0-5621-F
A6R47	0757-0440	7	1	RESISTOR 7.5K 1% .125W F TC=0+-100	24546	C4-1/8-T0-7501-F
A6R48	0757-0274	5		RESISTOR 1.21K 1% .125W F TC=0+-100	24546	C4-1/8-T0-1211-F
A6R49	0683-2225	3		RESISTOR 2.7K 5% .25W FC TC=-400/+700	01121	CB2225
A6R50	0683-3305	2		RESISTOR 33 5% .25W FC TC=-400/+500	01121	CB3305
A6R51	0683-3305	2		RESISTOR 33 5% .25W FC TC=-400/+500	01121	CB3305
A6R52	0757-0442	9		RESISTOR 10K 1% .125W F TC=0+-100	24546	C4-1/8-T0-1002-F
A6R53	0690-3153	9	1	RESISTOR 3.03K 1% .125W F TC=0+-100	24546	C4-1/8-T0-3031-F
A6R54	0683-2225	3		RESISTOR 2.7K 5% .25W FC TC=-400/+700	01121	CB2225
A6R55	0683-1525	4	1	RESISTOR 1.5K 5% .25W FC TC=-400/+700	01121	CB1525
A6U1	1826-0139	9	1	IC OP AMP GP DUAL 8-DIP-P PKG	01928	CA1458G
A6U2	1826-0065	0	1	IC COMPARATOR PRCN 8-DIP-P PKG	01295	SN72311P
A6U3	1820-1443	1	1	IC CNTR TTL LS 4-BIT BINARY ASYNCHRO	01295	SN57204
A6U4	1820-0630	3	1	IC MISC TTL	04713	MC4044P
A6U5	1826-0319	7	1	IC OP AMP LOW BIAS H-TMPD TO-99 PKG	04713	LF356G
A6Y1	0410-1379	9	1	CRYSTAL-QUARTZ 99.99K	28480	0410-1379
	1400-0249	0	1	CABLE TIE .062-.625-DIA .021-WD NYL	06383	PLT1M-8
	5001-0176	7	2	STRAP-GROUND	28480	5001-0173
	9170-0029	3	3	CORE-SHIELDING BEAD	28480	9170-0029
	04193-00604	6	3	SHIELD-BOX	28480	04193-00604
	04193-00607	9	3	SHIELD-BOX	28480	04193-00607
	64193-60006	8	1	COVER	28480	04193-60006
	04193-26506	0	1	PCBD BLANK	28480	04193-26506

See introduction to this section for ordering information
 *Indicates factory selected value

Table 6-3. Replaceable Parts

Reference Designation	HP Part Number	C D	Qty	Description	Mfr Code	Mfr Part Number
A7						
A7	04193-66507	6	1	DIVIDER BOARD ASSEMBLY	28480	04193-66507
A7C1	0160-2437	1	1	CAPACITOR-FXD 5000PF +80 -20% 200V	28480	0160-2437
A7C2	0160-4832	4	5	CAPACITOR-FXD .01UF +-10% 100VDC CER	28480	0160-4832
A7C3	0160-4835	7	3	CAPACITOR-FXD .1UF +-10% 50VDC CER	28480	0160-4835
A7C4	0160-4835	7	3	CAPACITOR-FXD .1UF +-10% 50VDC CER	28480	0160-4835
A7C5	0160-4832	4	5	CAPACITOR-FXD .01UF +-10% 100VDC CER	28480	0160-4832
A7C6	0180-0228	6	3	CAPACITOR-FXD 22UF+-10% 15VDC TA	56289	150D226X9015B2
A7C7	0180-0228	6	3	CAPACITOR-FXD 22UF+-10% 15VDC TA	56289	150D226X9015B2
A7C8	0180-0291	3	3	CAPACITOR-FXD 1UF+-10% 35VDC TA	56289	150D105X9035A2
A7C9	0180-0291	3	3	CAPACITOR-FXD 1UF+-10% 35VDC TA	56289	150D105X9035A2
A7C10	0180-0291	3	3	CAPACITOR-FXD 1UF+-10% 35VDC TA	56289	150D105X9035A2
A7C11	0160-4832	4	5	CAPACITOR-FXD .01UF +-10% 100VDC CER	28480	0160-4832
A7C12	0160-4574	1	3	CAPACITOR-FXD 1000PF +-10% 100VDC CER	28480	0160-4574
A7C13	0160-4832	4	5	CAPACITOR-FXD .01UF +-10% 100VDC CER	28480	0160-4832
A7C14	0160-4574	1	3	CAPACITOR-FXD 1000PF +-10% 100VDC CER	28480	0160-4574
A7C15	0160-4574	1	3	CAPACITOR-FXD 1000PF +-10% 100VDC CER	28480	0160-4574
A7C16	0160-4835	7	3	CAPACITOR-FXD .1UF +-10% 50VDC CER	28480	0160-4835
A7C17	0180-0228	6	3	CAPACITOR-FXD 22UF+-10% 15VDC TA	56289	150D226X9015B2
A7C18	0160-4832	4	5	CAPACITOR-FXD .01UF +-10% 100VDC CER	28480	0160-4832
A7L1	9140-0114	4	2	INDUCTOR RF-CH-MID 10UH 10% .166DX.355LG	28480	9140-0114
A7L2	9100-1618	1	2	INDUCTOR RF-CH-MID 5.6UH 10%	28480	9100-1618
A7L3	9100-1618	1	2	INDUCTOR RF-CH-MID 5.6UH 10%	28480	9100-1618
A7L4	9140-0114	4	2	INDUCTOR RF-CH-MID 10UH 10% .166DX.395LG	28480	9140-0114
A7R1	0683-1025	9	1	RESISTOR 1K 5% .25W FC TC=-400/+600	01121	CB1025
A7R2	0683-2245	7	2	RESISTOR 220K 5% .25W FC TC=-800/+900	01121	CB2245
A7R3	0683-2245	7	2	RESISTOR 220K 5% .25W FC TC=-800/+900	01121	CB2245
A7R4	0683-1845	1	1	RESISTOR 180K 5% .25W FC TC=-800/+900	01121	CB1845
A7R5	0757-0277	3	1	RESISTOR 49.9 1% .125W F TC=0+-100	24546	C4-1/B-T0-4992-F
A7R6	0683-2245	2	1	RESISTOR 220K 5% .25W FC TC=-800/+900	01121	CB2245
A7R7	0683-2215	6	2	RESISTOR 220 5% .25W FC TC=-400/+600	01121	CB2215
A7R8	0683-2215	6	2	RESISTOR 220 5% .25W FC TC=-400/+600	01121	CB2215
A7R9	1910-0204	5	1	NETWORK-RES B-STP1.0K OHM X 7	01121	208A192
A7U1	1820-1430	3	1	IC CNTR TTL LS BIN SYNCHRD POS-EDGE-TRIG	01295	SN74LS161AN
A7U2	1820-1423	4	2	IC MV TTL LS MONOSTBL RETRIG DUAL	01295	SN74LS123N
A7U3	1820-1112	8	4	IC FF TTL LS D-TYPE POS-EDGE-TRIG	01295	SN74LS74AN
A7U4	1820-1194	6	2	IC CNTR TTL LS BIN UP/DOWN SYNCHRD	01295	SN74LS193N
A7U5	1820-1888	5	1	IC PRESCR ECL	04713	MC17813L
A7U6	1820-1429	0	8	IC CNTR TTL LS DECD SYNCHRD	01295	SN74LS160AN
A7U7	1820-1144	6	1	IC GATE TTL LS NOR QUAD 2-INP	01295	SN74LS02N
A7U8	1820-1423	4	2	IC MV TTL LS MONOSTBL RETRIG DUAL	01295	SN74LS123N
A7U9	1820-1197	9	1	IC GATE TTL LS NAND QUAD 2-INP	01295	SN74LS00N
A7U10	1820-1206	1	1	IC GATE TTL LS NOR TPL 3-INP	01295	SN74LS27N
A7U11	1820-1194	6	2	IC CNTR TTL LS BIN UP/DOWN SYNCHRD	01295	SN74LS193N
A7U12	1820-0630	3	1	IC MISC TTL	04713	MC4044P
A7U13	1820-1202	7	1	IC GATE TTL LS NAND TPL 3-INP	01295	SN74LS10N
A7U14	1820-1429	0	8	IC CNTR TTL LS DECD SYNCHRD	01295	SN74LS160AN
A7U15	1820-1429	0	8	IC CNTR TTL LS DECD SYNCHRD	01295	SN74LS160AN
A7U16	1820-1204	9	1	IC GATE TTL LS NAND DUAL 4-INP	01295	SN74LS20N
A7U17	1820-1112	8	4	IC FF TTL LS D-TYPE POS-EDGE-TRIG	01295	SN74LS74AN
A7U18	1820-1199	1	2	IC INV TTL LS HEX 1-INP	01295	SN74LS04N
A7U19	1820-1416	5	1	IC SCHMITT-TRIG TTL LS INV HEX 1-INP	01295	SN74LS14N
A7U20	1820-1470	1	1	IC MIXR/DATA-SEL TTL LS 2-TO-1-LINE QUAD	01295	SN74LS157N
A7U21	1820-1244	7	1	IC MIXR/DATA-SEL TTL LS 4-TO-1-LINE DUAL	01295	SN74LS153N
A7U22	1820-1429	0	8	IC CNTR TTL LS DECD SYNCHRD	01295	SN74LS160AN
A7U23	1820-1429	0	8	IC CNTR TTL LS DECD SYNCHRD	01295	SN74LS160AN
A7U24	1820-1429	0	8	IC CNTR TTL LS DECD SYNCHRD	01295	SN74LS160AN
A7U25	1820-1429	0	8	IC CNTR TTL LS DECD SYNCHRD	01295	SN74LS160AN
A7U26	1820-1429	0	8	IC CNTR TTL LS DECD SYNCHRD	01295	SN74LS160AN
A7U27	1820-1112	8	4	IC FF TTL LS D-TYPE POS-EDGE-TRIG	01295	SN74LS74AN
A7U28	1820-1112	8	4	IC FF TTL LS D-TYPE POS-EDGE-TRIG	01295	SN74LS74AN
A7U29	1820-1199	1	2	IC INV TTL LS HEX 1-INP	01295	SN74LS04N
A7U30	1820-1251	6	1	IC CNTR TTL LS DECD ASYNCHRD	01295	SN74LS196N
	5001-0176	7	2	STRAP-GROUND	28480	5001-0176
	04193-60007	9	1	COVER	28480	04193-60007
	04193-26507	0	1	PCBD BLANK	28480	04193-26507

See introduction to this section for ordering information
 *Indicates factory selected value

Table 6-3. Replaceable Parts

Reference Designation	HP Part Number	C D	Qty	Description	Mfr Code	Mfr Part Number
A8						
AB	04123-66500	7	1	CRYSTAL OSCILLATOR BOARD ASSEMBLY	20400	04123-66500
ABC1	0160-2437	1	2	CAPACITOR-FDTHRU 5000PF +80 -20% 200V	20400	0160-2437
ABC2	0160-2437	1	2	CAPACITOR-FDTHRU 5000PF +80 -20% 200V	20400	0160-2437
ABC3	0121-0453	5	2	CAPACITOR-V TRMR-ATR 1.3-5.4PF 175V	74970	187-0303-125
ABC4	0160-4385	2	3	CAPACITOR-FXD 15PF +-5% 200VDC CER 0+-30	51642	200-200-NP0-150J
ABC5	0160-5495	3	7	CAPACITOR-FXD 3.9PF +-1.5PF 200VDC CER		
ABC6	0160-3879	7	20	CAPACITOR-FXD .01UF +-20% 100VDC CER	20400	0160-3879
ABC7	0160-5495	3		CAPACITOR-FXD 3.9PF +-1.5PF 200VDC CER		
ABC8	0160-3879	7		CAPACITOR-FXD .01UF +-20% 100VDC CER	20400	0160-3879
ABC9	0160-3879	7		CAPACITOR-FXD .01UF +-20% 100VDC CER	20400	0160-3879
ABC10	0160-3879	7		CAPACITOR-FXD .01UF +-20% 100VDC CER	20400	0160-3879
ABC11	0160-3879	6	3	CAPACITOR-FXD 1000PF +-20% 100VDC CER	20400	0160-3879
ABC12	0160-3879	7		CAPACITOR-FXD .01UF +-20% 100VDC CER	20400	0160-3879
ABC13	0160-4385	2		CAPACITOR-FXD 15PF +-5% 200VDC CER 0+-30	51642	200-200-NP0-150J
ABC14	0160-5495	3		CAPACITOR-FXD 3.9PF +-1.5PF 200VDC CER		
ABC15	0160-5495	3		CAPACITOR-FXD 3.9PF +-1.5PF 200VDC CER		
ABC16	0160-3879	7		CAPACITOR-FXD .01UF +-20% 100VDC CER	20400	0160-3879
ABC17	0160-3879	7		CAPACITOR-FXD .01UF +-20% 100VDC CER	20400	0160-3879
ABC18	0160-3879	7		CAPACITOR-FXD .01UF +-20% 100VDC CER	20400	0160-3879
ABC19	0160-4385	2		CAPACITOR-FXD 15PF +-5% 200VDC CER 0+-30	51642	200-200-NP0-150J
ABC20	0160-5495	3		CAPACITOR-FXD 3.9PF +-1.5PF 200VDC CER		
ABC21	0160-5495	3		CAPACITOR-FXD 3.9PF +-1.5PF 200VDC CER		
ABC22	0160-5495	3		CAPACITOR-FXD 3.9PF +-1.5PF 200VDC CER		
ABC23	0160-3879	7		CAPACITOR-FXD .01UF +-20% 100VDC CER	20400	0160-3879
ABC24	0160-3879	7		CAPACITOR-FXD .01UF +-20% 100VDC CER	20400	0160-3879
ABC25	0160-3879	7		CAPACITOR-FXD .01UF +-20% 100VDC CER	20400	0160-3879
ABC26	0160-4835	7	9	CAPACITOR-FXD .1UF +-10% 50VDC CER	20400	0160-4835
ABC27	0160-3879	7		CAPACITOR-FXD .01UF +-20% 100VDC CER	20400	0160-3879
ABC28	0121-0453	5		CAPACITOR-V TRMR-ATR 1.3-5.4PF 175V	74970	187-0303-125
ABC29 *	0160-5617	7	1	CAPACITOR-FXD 3PF +-1.25PF 500VDC CER	20400	0160-2243
ABC30	0160-5619	7	1	CAPACITOR-FXD 8PF +-1.25PF 500VDC CER		
ABC31	0160-5618	1	1	CAPACITOR-FXD 5PF +-1.25PF 500VDC CER		
ABC32	0160-3879	7		CAPACITOR-FXD .01UF +-20% 100VDC CER	20400	0160-3879
ABC33	0160-3879	7		CAPACITOR-FXD .01UF +-20% 100VDC CER	20400	0160-3879
ABC34	0160-3879	7		CAPACITOR-FXD .01UF +-20% 100VDC CER	20400	0160-3879
ABC35	0180-1083	3	3	CAPACITOR-FXD 330UF 25VDC AL	20400	0180-1083
ABC36	0160-3879	7		CAPACITOR-FXD .01UF +-20% 100VDC CER	20400	0160-3879
ABC37	0180-0229	7	3	CAPACITOR-FXD 330UF +-10% 10VDC TA	56207	150D336X9010E2
ABC38	0160-3879	7		CAPACITOR-FXD .01UF +-20% 100VDC CER	20400	0160-3879
ABC39	0160-3879	7		CAPACITOR-FXD .01UF +-20% 100VDC CER	20400	0160-3879
ABC40	0160-3879	7		CAPACITOR-FXD .01UF +-20% 100VDC CER	20400	0160-3879
ABC41	0180-0229	7		CAPACITOR-FXD 330UF +-10% 10VDC TA	56207	150D336X9010E2
ABC42	0180-2979	8	1	CAPACITOR-FXD 220UF +-20% 16VDC AL	20400	0180-2979
ABC43	0180-1746	5	1	CAPACITOR-FXD 150UF +-10% 28VDC TA	56207	150D156X9020E2
ABC44	0160-3879	7		CAPACITOR-FXD .01UF +-20% 100VDC CER	20400	0160-3879
ABC45	0160-3879	7		CAPACITOR-FXD .01UF +-20% 100VDC CER	20400	0160-3879
ABC46	0160-4835	7		CAPACITOR-FXD .1UF +-10% 50VDC CER	20400	0160-4835
ABC47	0160-4835	7		CAPACITOR-FXD .1UF +-10% 50VDC CER	20400	0160-4835
ABC48	0160-4835	7		CAPACITOR-FXD .1UF +-10% 50VDC CER	20400	0160-4835
ABC49	0160-4835	7		CAPACITOR-FXD .1UF +-10% 50VDC CER	20400	0160-4835
ABC50	0160-3879	7		CAPACITOR-FXD .01UF +-20% 100VDC CER	20400	0160-3879
ABC51	0160-4835	7		CAPACITOR-FXD .1UF +-10% 50VDC CER	20400	0160-4835
ABC52	0160-4835	7		CAPACITOR-FXD .1UF +-10% 50VDC CER	20400	0160-4835
ABC53	0180-1083	3		CAPACITOR-FXD 330UF 25VDC AL	20400	0180-1083
ABC54	0180-1083	3		CAPACITOR-FXD 330UF 25VDC AL	20400	0180-1083
ABC55	0160-3879	7		CAPACITOR-FXD .01UF +-20% 100VDC CER	20400	0160-3879
ABC56	0160-4835	7		CAPACITOR-FXD .1UF +-10% 50VDC CER	20400	0160-4835
ABC57	0160-3878	6		CAPACITOR-FXD 1000PF +-20% 100VDC CER	20400	0160-3878
ABC58	0160-3878	6		CAPACITOR-FXD 1000PF +-20% 100VDC CER	20400	0160-3878
ABC59	0160-3879	7		CAPACITOR-FXD .01UF +-20% 100VDC CER	20400	0160-3879
ABC60	0160-3879	7		CAPACITOR-FXD .01UF +-20% 100VDC CER	20400	0160-3879
ABC61	0160-3879	7		CAPACITOR-FXD .01UF +-20% 100VDC CER	20400	0160-3879
ABC62	0180-0229	7		CAPACITOR-FXD 330UF +-10% 10VDC TA	56207	150D336X9010E2
ABC63	0160-3879	7		CAPACITOR-FXD .01UF +-20% 100VDC CER	20400	0160-3879
ABC64	0160-4835	7		CAPACITOR-FXD .1UF +-10% 50VDC CER	20400	0160-4835
ABC65	0160-3879	7		CAPACITOR-FXD .01UF +-20% 100VDC CER	20400	0160-3879
ABDR1	1902-3171	7	1	DIODE-ZNR 11V 5% DO-35 PD=.4W TC=+.362%	20400	1902-3171
ABL1	9100-2247	4	2	INDUCTOR RF-CH-MED 100NH 10% .105DX.26LG	20400	9100-2247
ABL2	9100-2250	9	1	INDUCTOR RF-CH-MED 100NH 10% .105DX.26LG	20400	9100-2250
ABL3	9100-2891	4	3	INDUCTOR RF-CH-MED 50NH 10% .105DX.26LG	20400	9100-2891
ABL4	9100-2891	4		INDUCTOR RF-CH-MED 50NH 10% .105DX.26LG	20400	9100-2891
ABL5	9100-2251	0	1	INDUCTOR RF-CH-MED 220NH 10% .105DX.26LG	20400	9100-2251

See introduction to this section for ordering information
 *Indicates factory selected value

Table 6-3. Replaceable Parts

Reference Designation	HP Part Number	C D	Qty	Description	Mfr Code	Mfr Part Number
ABL6	9100-2248	5	4	INDUCTOR RF-CH-MLD 120MH 10% .1050X.26LG	28480	9100-2248
ABL7	9100-2249	6	4	INDUCTOR RF-CH-MLD 150MH 10% .1050X.26LG	28488	9100-2249
ABL8	9100-2248	5		INDUCTOR RF-CH-MLD 120MH 10% .1050X.26LG	28480	9100-2248
ABL9	9100-2249	6		INDUCTOR RF-CH-MLD 150MH 10% .1050X.26LG	28488	9100-2249
ABL10	9100-2248	5		INDUCTOR RF-CH-MLD 120MH 10% .1050X.26LG	28480	9100-2248
ABL11	9100-2249	6		INDUCTOR RF-CH-MLD 150MH 10% .1050X.26LG	28488	9100-2249
ABL12	9100-2248	5		INDUCTOR RF-CH-MLD 120MH 10% .1050X.26LG	28480	9100-2248
ABL13	9100-2249	6		INDUCTOR RF-CH-MLD 150MH 10% .1050X.26LG	28488	9100-2249
ABL14	9100-2621	4		INDUCTOR RF-CH-MLD 50MH 10% .1050X.26LG	28480	9100-2621
ABL15	9140-0158	6	5	INDUCTOR RF-CH-MLD 100 10% .1050X.26LG	28488	9140-0158
ABL16	9100-2247	4		INDUCTOR RF-CH-MLD 100MH 10% .1050X.26LG	28480	9100-2247
ABL17	9140-0158	6		INDUCTOR RF-CH-MLD 100 10% .1050X.26LG	28488	9140-0158
ABL18	9140-0158	6		INDUCTOR RF-CH-MLD 100 10% .1050X.26LG	28488	9140-0158
ABL19	9140-0114	4	3	INDUCTOR RF-CH-MLD 100H 10% .1660X.385LG	28480	9140-0114
ABL20	9140-0114	4		INDUCTOR RF-CH-MLD 100H 10% .1660X.385LG	28488	9140-0114
ABL21	9140-0158	6		INDUCTOR RF-CH-MLD 100 10% .1050X.26LG	28488	9140-0158
ABL22	9140-0158	6		INDUCTOR RF-CH-MLD 100 10% .1050X.26LG	28488	9140-0158
ABL23	9140-0114	4		INDUCTOR RF-CH-MLD 100H 10% .1660X.385LG	28488	9140-0114
ABQ1	1854-0345	8	7	TRANSISTOR NPN 2N5179 SI T0-72 PD=200MW	04713	2N5179
ABQ2	1854-0345	8		TRANSISTOR NPN 2N5179 SI T0-72 PD=200MW	04713	2N5179
ABQ3	1854-0345	8		TRANSISTOR NPN 2N5179 SI T0-72 PD=200MW	04713	2N5179
ABQ4	1854-0345	8		TRANSISTOR NPN 2N5179 SI T0-72 PD=200MW	04713	2N5179
ABQ5	1854-0345	8		TRANSISTOR NPN 2N5179 SI T0-72 PD=200MW	04713	2N5179
ABQ6	1854-0810	2	1	TRANSISTOR NPN S1 PD=625MW FT=200MHZ	28488	1854-0810
ABQ7	1854-0345	8		TRANSISTOR NPN 2N5179 SI T0-72 PD=200MW	04713	2N5179
ABQ8	1854-0345	8		TRANSISTOR NPN 2N5179 SI T0-72 PD=200MW	04713	2N5179
ABR1	2100-3349	2	1	RESISTOR TRMR 100 10% C SIDE-ADJ 1-TRN	28480	2100-3349
ABR2	0757-0316	6	1	RESISTOR 42.2 1% .125W F TC=0+-100	24546	C4-1/8-T0-4222-F
ABR3	0757-0439	4	3	RESISTOR 6.81K 1% .125W F TC=0+-100	24546	C4-1/8-T0-6811-F
ABR4	0698-3155	1	2	RESISTOR 4.64K 1% .125W F TC=0+-100	24546	C4-1/8-T0-4641-F
ABR5	0683-3305	2	1	RESISTOR 33 5% .25W FC TC=-400/+500	01121	CB3305
ABR6	0757-0439	4		RESISTOR 6.81K 1% .125W F TC=0+-100	24546	C4-1/8-T0-6811-F
ABR7	0698-3155	1		RESISTOR 4.64K 1% .125W F TC=0+-100	24546	C4-1/8-T0-4641-F
ABR8	0698-3132	4	1	RESISTOR 261 1% .125W F TC=0+-100	24546	C4-1/8-T0-2610-F
ABR9	0757-0327	3	1	RESISTOR 68.1 1% .125W F TC=0+-100	24546	C4-1/8-T0-6811-F
ABR10	0683-4705	8	3	RESISTOR 47 5% .25W FC TC=-400/+500	01121	CB4705
ABR11	0683-6805	3	2	RESISTOR 68 5% .25W FC TC=-400/+500	01121	CB6805
ABR12	0757-0419	1	1	RESISTOR 681 1% .125W F TC=0+-100	24546	0757-0419
ABR13	0698-3153	9	2	RESISTOR 3.83K 1% .125W F TC=0+-100	24546	C4-1/8-T0-3831-F
ABR14	0698-0085	0	1	RESISTOR 2.61K 1% .125W F TC=0+-100	24546	C4-1/8-T0-2611-F
ABR15	0683-3315	4	4	RESISTOR 330 5% .25W FC TC=-400/+500	01121	CB3315
ABR16	0683-3315	4		RESISTOR 330 5% .25W FC TC=-400/+500	01121	CB3315
ABR17	0757-0412	3	1	RESISTOR 345 1% .125W F TC=0+-100	24546	C4-1/8-T0-345R-F
ABR18	0683-5615	1	5	RESISTOR 560 5% .25W FC TC=-400/+500	01121	CB5615
ABR19	0757-0280	3	1	RESISTOR 1K 1% .125W F TC=0+-100	24546	C4-1/8-T0-1001-F
ABR20	0698-3153	9		RESISTOR 3.83K 1% .125W F TC=0+-100	24546	C4-1/8-T0-3831-F
ABR21	0757-0439	4		RESISTOR 6.81K 1% .125W F TC=0+-100	24546	C4-1/8-T0-6811-F
ABR22	0698-3435	9	1	RESISTOR 38.3 5% .25W FC TC=-400/+500	01121	CB3835
ABR23	0683-5615	1		RESISTOR 560 5% .25W FC TC=-400/+500	01121	CB5615
ABR24	0683-1025	9	1	RESISTOR 1K 5% .25W FC TC=-400/+500	01121	CB1025
ABR25	0683-5615	1		RESISTOR 560 5% .25W FC TC=-400/+500	01121	CB5615
ABR26	0757-0277	8	1	RESISTOR 49.9 1% .125W F TC=0+-100	24546	C4-1/8-T0-4922-F
ABR27	0683-5615	1		RESISTOR 560 5% .25W FC TC=-400/+500	01121	CB5615
ABR28	0683-3915	0	1	RESISTOR 390 5% .25W FC TC=-400/+500	01121	CB3915
ABR29	0683-3315	4		RESISTOR 330 5% .25W FC TC=-400/+500	01121	CB3315
ABR30	0683-4705	8		RESISTOR 47 5% .25W FC TC=-400/+500	01121	CB4705
ABR31	0698-3447	4	1	RESISTOR 422 1% .125W F TC=0+-100	24546	C4-1/8-T0-422R-F
ABR32	0757-0398	4	1	RESISTOR 75 1% .125W F TC=0+-100	24546	C4-1/8-T0-75R-F
ABR33	0698-3432	7	1	RESISTOR 26.1 1% .125W F TC=0+-100	03688	DB55-1/8-T0-2611-F
ABR34	0698-3434	4	1	RESISTOR 34.8 1% .125W F TC=0+-100	24546	C4-1/8-T0-348R-F
ABR35	0683-4705	8		RESISTOR 47 5% .25W FC TC=-400/+500	01121	CB4705
ABR36	0698-0082	7	1	RESISTOR 464 1% .125W F TC=0+-100	24546	C4-1/8-T0-464R-F
ABR37	0757-0200	7	1	RESISTOR 5.62K 1% .125W F TC=0+-100	24546	C4-1/8-T0-5621-F
ABR38	0757-0428	1	1	RESISTOR 1.62K 1% .125W F TC=0+-100	24546	C4-1/8-T0-1621-F
ABR39	0698-0084	9	1	RESISTOR 2.15K 1% .125W F TC=0+-100	24546	C4-1/8-T0-2151-F
ABR40	0698-3152	8	1	RESISTOR 3.48K 1% .125W F TC=0+-100	24546	C4-1/8-T0-3481-F
ABR41	0683-3315	4		RESISTOR 330 5% .25W FC TC=-400/+500	01121	CB3315
ABR42	0698-3446	3	1	RESISTOR 393 1% .125W F TC=0+-100	24546	C4-1/8-T0-393R-F
ABR43	0683-6805	3		RESISTOR 68 5% .25W FC TC=-400/+500	01121	CB6805
ABR44	0683-2715	6	1	RESISTOR 276 5% .25W FC TC=-400/+500	01121	CB2715
ABR45	0683-4715	0	1	RESISTOR 470 5% .25W FC TC=-400/+500	01121	CB4715
ABR46	0683-5615	1		RESISTOR 560 5% .25W FC TC=-400/+500	01121	CB5615
ABT1	9140-0641	0	1	RF TRANSFORMER	28480	9140-0641

See introduction to this section for ordering information
 *Indicates factory selected value

Table 6-3. Replaceable Parts

Reference Designation	HP Part Number	C D	Qty	Description	Mfr Code	Mfr Part Number
ABU1	1820-1888	5	1	IC PRESCR ECL	04713	MC12013L
ABU2	1820-0869	8	2	IC RCVR ECL LINE RCVR QUAD 2-INP	04713	MC10115P
ABU3	1820-0809	8		IC RCVR ECL LINE RCVR QUAD 2-INP	04713	MC10115P
ABY1	0410-1338	4	1	CRYSTAL-QUARTZ 100MHZ	28486	0410-1338
	5001-0173	7	2	STRAP-GROUND	28480	5001-0173
	04193-00604	6	2	SHIELD BOX	28480	04193-00604
	04193-00606	8	1	SHIELD BOX	28480	04193-00606
	04193-00607	9	3	SHIELD BOX	28480	04193-00607
	04193-60008	0	1	COVER	28480	04193-60008
	9170-0029	3	2	CORE-SHIELDING BEAD	28480	9170-0029
	04193-26508	0	1	PCBD BLANK	28480	04193-26508

See introduction to this section for ordering information
 *Indicates factory selected value

Table 6-3. Replaceable Parts

Reference Designation	HP Part Number	C D	Qty	Description	Mfr Code	Mfr Part Number
A9						
A9	94193-66509	B	1	MIXER BOARD ASSEMBLY	28480	94193-66509
A9C1	0160-2437	1	2	CAPACITOR-FDTHRU 5000PF +80 -20% 200V	28480	0160-2437
A9C2	0160-2437	1	1	CAPACITOR-FDTHRU 5000PF +80 -20% 200V	28480	0160-2437
A9C3	0160-3875	3	3	CAPACITOR-FXD 22PF +-5% 200VDC CER 0+-30	28480	0160-3875
A9C4	0160-3875	3	3	CAPACITOR-FXD 22PF +-5% 200VDC CER 0+-30	28480	0160-3875
A9C5	0160-3875	3	3	CAPACITOR-FXD 22PF +-5% 200VDC CER 0+-30	28480	0160-3875
A9C6	0160-0263	7	5	CAPACITOR-FXD .22UF +-20% 50VDC CER	28480	0160-0263
A9C7	0160-3879	7	8	CAPACITOR-FXD .01UF +-20% 100VDC CER	28480	0160-3879
A9C8	0160-3879	7	7	CAPACITOR-FXD .01UF +-20% 100VDC CER	28480	0160-3879
A9C9	0160-4835	7	15	CAPACITOR-FXD .1UF +-10% 50VDC CER	28480	0160-4835
A9C10	0160-0263	7	7	CAPACITOR-FXD .22UF +-20% 50VDC CER	28480	0160-0263
A9C11	0160-2246	8	1	CAPACITOR-FXD 3.6PF +--.25PF 500VDC CER	28480	0160-2246
A9C12	0160-4835	7	1	CAPACITOR-FXD .1UF +-10% 50VDC CER	28480	0160-4835
A9C13	0160-2265	3	1	CAPACITOR-FXD 22PF +-5% 500VDC CER 0+-30	28480	0160-2265
A9C14	0160-3879	7	7	CAPACITOR-FXD .01UF +-20% 100VDC CER	28480	0160-3879
A9C15	0160-3879	7	7	CAPACITOR-FXD .01UF +-20% 100VDC CER	28480	0160-3879
A9C16	0160-4835	7	7	CAPACITOR-FXD .1UF +-10% 50VDC CER	28480	0160-4835
A9C17	0160-4835	7	7	CAPACITOR-FXD .1UF +-10% 50VDC CER	28480	0160-4835
A9C18	0160-4835	7	7	CAPACITOR-FXD .1UF +-10% 50VDC CER	28480	0160-4835
A9C19	0160-2250	6	2	CAPACITOR-FXD 5.1PF +--.25PF 500VDC CER	28480	0160-2250
A9C20	0160-4835	7	7	CAPACITOR-FXD .1UF +-10% 50VDC CER	28480	0160-4835
A9C21	0160-4835	7	7	CAPACITOR-FXD .1UF +-10% 50VDC CER	28480	0160-4835
A9C22	0160-3879	7	7	CAPACITOR-FXD .01UF +-20% 100VDC CER	28480	0160-3879
A9C23	0160-4386	5	1	CAPACITOR-FXD 33PF +-5% 300VDC MICA	28480	0160-4386
A9C24	0160-4832	4	2	CAPACITOR-FXD .01UF +-10% 100VDC CER	28480	0160-4832
A9C25	0160-3877	5	2	CAPACITOR-FXD 100PF +-20% 200VDC CER	28480	0160-3877
A9C26	0160-0263	7	7	CAPACITOR-FXD .22UF +-20% 50VDC CER	28480	0160-0263
A9C27	0180-0229	7	3	CAPACITOR-FXD 330UF+-10% 10VDC TA	56289	150D336X9010R2
A9C28	0160-4835	7	7	CAPACITOR-FXD .1UF +-10% 50VDC CER	28480	0160-4835
A9C29	0160-4835	7	7	CAPACITOR-FXD .1UF +-10% 50VDC CER	28480	0160-4835
A9C30	0160-4835	7	7	CAPACITOR-FXD .1UF +-10% 50VDC CER	28480	0160-4835
A9C31	0160-3879	7	7	CAPACITOR-FXD .01UF +-20% 100VDC CER	28480	0160-3879
A9C32	0160-4835	7	7	CAPACITOR-FXD .1UF +-10% 50VDC CER	28480	0160-4835
A9C33	0160-2250	6	6	CAPACITOR-FXD 5.1PF +--.25PF 500VDC CER	28480	0160-2250
A9C34	0160-2264	2	2	CAPACITOR-FXD 20PF +-5% 500VDC CER 0+-30	28480	0160-2264
A9C35	0160-3335	0	1	CAPACITOR-FXD 420PF +-10% 100VDC CER	28480	0160-3335
A9C36	0160-0263	7	7	CAPACITOR-FXD .22UF +-20% 50VDC CER	28480	0160-0263
A9C37	0160-3879	7	7	CAPACITOR-FXD .01UF +-20% 100VDC CER	28480	0160-3879
A9C38	0160-3877	5	7	CAPACITOR-FXD 100PF +-20% 200VDC CER	28480	0160-3877
A9C39	0160-4835	7	7	CAPACITOR-FXD .1UF +-10% 50VDC CER	28480	0160-4835
A9C40	0160-4835	7	7	CAPACITOR-FXD .1UF +-10% 50VDC CER	28480	0160-4835
A9C41	0160-4835	7	7	CAPACITOR-FXD .1UF +-10% 50VDC CER	28480	0160-4835
A9C42	0160-4835	7	7	CAPACITOR-FXD .1UF +-10% 50VDC CER	28480	0160-4835
A9C43	0160-0263	7	7	CAPACITOR-FXD .22UF +-20% 50VDC CER	28480	0160-0263
A9C44	0160-2264	2	2	CAPACITOR-FXD 20PF +-5% 500VDC CER 0+-30	28480	0160-2264
A9C45	0160-4832	4	4	CAPACITOR-FXD .01UF +-10% 100VDC CER	28480	0160-4832
A9C46	0160-3879	7	7	CAPACITOR-FXD .01UF +-20% 100VDC CER	28480	0160-3879
A9C47	0180-0229	7	7	CAPACITOR-FXD 330UF+-10% 10VDC TA	56289	150D336X9010R2
A9C48	0180-0229	7	7	CAPACITOR-FXD 330UF+-10% 10VDC TA	56289	150D336X9010R2
A9C49	0180-1746	5	4	CAPACITOR-FXD 150UF+-10% 20VDC TA	56289	150D156X9020R2
A9C50	0180-1746	5	5	CAPACITOR-FXD 150UF+-10% 20VDC TA	56289	150D156X9020R2
A9C51	0180-1746	5	5	CAPACITOR-FXD 150UF+-10% 20VDC TA	56289	150D156X9020R2
A9C52	0180-1746	5	5	CAPACITOR-FXD 150UF+-10% 20VDC TA	56289	150D156X9020R2
A9CR1	1901-0050	1	2	DIODE SWITCHING 80V 200MA 2NS DO-35	28480	1901-0050
A9CR2	1901-0050	1	1	DIODE SWITCHING 80V 200MA 2NS DO-35	28480	1901-0050
A9D1	1966-0235	6	1	DIODE-DOUBLE BALANCED MIXER	28480	1966-0235
A9L1	9100-2247	4	5	INDUCTOR RF-CH-M-D 100NH 10% .105DX.26LG	28480	9100-2247
A9L2	9100-2249	6	2	INDUCTOR RF-CH-M-D 150NH 10% .165DX.26LG	28480	9100-2249
A9L3	9100-2249	6	6	INDUCTOR RF-CH-M-D 150NH 10% .105DX.26LG	28480	9100-2249
A9L4	9100-2247	4	4	INDUCTOR RF-CH-M-D 100NH 10% .165DX.26LG	28480	9100-2247
A9L5	9140-0158	4	3	INDUCTOR RF-CH-M-D 10UH 10% .105DX.26LG	28480	9140-0158
A9L6	9140-0158	6	6	INDUCTOR RF-CH-M-D 10UH 10% .165DX.26LG	28480	9140-0158
A9L7	9100-2247	4	4	INDUCTOR RF-CH-M-D 100NH 10% .105DX.26LG	28480	9100-2247
A9L8	9140-0114	4	4	INDUCTOR RF-CH-M-D 10UH 10% .166DX.335LG	28480	9140-0114
A9L9	9100-2247	4	4	INDUCTOR RF-CH-M-D 100NH 10% .105DX.26LG	28480	9100-2247
A9L10	9100-2247	4	4	INDUCTOR RF-CH-M-D 100NH 10% .105DX.26LG	28480	9100-2247
A9L11	9140-0114	4	4	INDUCTOR RF-CH-M-D 10UH 10% .166DX.335LG	28480	9140-0114
A9L12	9140-0158	6	6	INDUCTOR RF-CH-M-D 10UH 10% .165DX.26LG	28480	9140-0158
A9L13	9140-0114	4	4	INDUCTOR RF-CH-M-D 10UH 10% .166DX.335LG	28480	9140-0114
A9L14	9140-0114	4	4	INDUCTOR RF-CH-M-D 10UH 10% .166DX.335LG	28480	9140-0114

See introduction to this section for ordering information
 *Indicates factory selected value

Table 6-3. Replaceable Parts

Reference Designation	HP Part Number	C D	Qty	Description	Mfr Code	Mfr Part Number
A9Q1	1854-0247	9	1	TRANSISTOR NPN SI TO-39 PD=1W FT=000MHZ	28480	1854-0247
A9Q2	1853-0018	0	4	TRANSISTOR PNP SI TO-72 PD=200MW FT=1GHZ	28480	1853-0018
A9Q3	1854-0345	0	3	TRANSISTOR NPN 2N5179 SI TO-72 PD=200MW	04713	2N5179
A9Q4	1853-0018	0	0	TRANSISTOR PNP SI TO-72 PD=200MW FT=1GHZ	28480	1853-0018
A9Q5	1854-0345	0	0	TRANSISTOR NPN 2N5179 SI TO-72 PD=200MW	04713	2N5179
A9Q6	1853-0018	0	0	TRANSISTOR PNP SI TO-72 PD=200MW FT=1GHZ	28480	1853-0018
A9Q7	1854-0345	0	0	TRANSISTOR NPN 2N5179 SI TO-72 PD=200MW	04713	2N5179
A9Q8	1853-0018	0	0	TRANSISTOR PNP SI TO-72 PD=200MW FT=1GHZ	28480	1853-0018
A9R1	0757-0277	0	5	RESISTOR 49.9 1% .125W F TC=0+-100	24546	C4-1/8-T0-4992-F
A9R2	0757-0398	4	1	RESISTOR 75 1% .125W F TC=0+-100	24546	C4-1/8-T0-75R0-F
A9R3	0757-0277	0	0	RESISTOR 49.9 1% .125W F TC=0+-100	24546	C4-1/8-T0-4992-F
A9R4	0757-0180	2	2	RESISTOR 31.6 1% .125W F TC=0+-100	28480	0757-0180
A9R5	0757-0180	2	2	RESISTOR 31.6 1% .125W F TC=0+-100	28480	0757-0180
A9R6	0757-0401	0	0	RESISTOR 100 1% .125W F TC=0+-100	24546	C4-1/8-T0-101-F
A9R7	0757-0274	5	4	RESISTOR 1.21K 1% .125W F TC=0+-100	24546	C4-1/8-T0-1211-F
A9R8	0698-3153	9	4	RESISTOR 3.83K 1% .125W F TC=0+-100	24546	C4-1/8-T0-3831-F
A9R9	0757-0441	0	0	RESISTOR 100 1% .125W F TC=0+-100	24546	C4-1/8-T0-101-F
A9R10	0698-3446	3	3	RESISTOR 393 1% .125W F TC=0+-100	24546	C4-1/8-T0-393R-F
A9R11	0757-0405	4	3	RESISTOR 162 1% .125W F TC=0+-100	24546	C4-1/8-T0-162R-F
A9R12	0698-3446	7	5	RESISTOR 196 1% .125W F TC=0+-100	24546	C4-1/8-T0-196R-F
A9R13	0698-3439	4	2	RESISTOR 178 1% .125W F TC=0+-100	24546	C4-1/8-T0-178R-F
A9R14	0757-0274	5	9	RESISTOR 1.21K 1% .125W F TC=0+-100	24546	C4-1/8-T0-1211-F
A9R15	0698-3153	9	5	RESISTOR 3.83K 1% .125W F TC=0+-100	24546	C4-1/8-T0-3831-F
A9R16	0757-0316	6	3	RESISTOR 42.2 1% .125W F TC=0+-100	24546	C4-1/8-T0-42R2-F
A9R17	0698-3446	3	3	RESISTOR 393 1% .125W F TC=0+-100	24546	C4-1/8-T0-393R-F
A9R18	0757-0401	0	0	RESISTOR 100 1% .125W F TC=0+-100	24546	C4-1/8-T0-101-F
A9R19	0757-0417	0	3	RESISTOR 562 1% .125W F TC=0+-100	24546	C4-1/8-T0-562R-F
A9R20	0757-0401	0	0	RESISTOR 100 1% .125W F TC=0+-100	24546	C4-1/8-T0-101-F
A9R21	0683-3315	4	2	RESISTOR 330 5% .25W FC TC=-400/+600	01121	C83315
A9R22	0683-2215	1	2	RESISTOR 220 5% .25W FC TC=-400/+600	01121	C82215
A9R23	1810-0203	5	2	NETWORK RES 8-SIP470.0 OHM X 7	01121	208A471
A9R24	0698-3440	7	0	RESISTOR 196 1% .125W F TC=0+-100	24546	C4-1/8-T0-196R-F
A9R25	0757-0401	0	0	RESISTOR 100 1% .125W F TC=0+-100	24546	C4-1/8-T0-101-F
A9R26	0757-0277	0	8	RESISTOR 49.9 1% .125W F TC=0+-100	24546	C4-1/8-T0-4992-F
A9R27	0698-3153	8	0	RESISTOR 3.83K 1% .125W F TC=0+-100	24546	C4-1/8-T0-3831-F
A9R28	0757-0274	5	0	RESISTOR 1.21K 1% .125W F TC=0+-100	24546	C4-1/8-T0-1211-F
A9R29	0757-0316	6	0	RESISTOR 42.2 1% .125W F TC=0+-100	24546	C4-1/8-T0-42R2-F
A9R30	0698-3440	7	0	RESISTOR 196 1% .125W F TC=0+-100	24546	C4-1/8-T0-196R-F
A9R31	0757-0405	4	0	RESISTOR 162 1% .125W F TC=0+-100	24546	C4-1/8-T0-162R-F
A9R32	0698-3446	3	0	RESISTOR 393 1% .125W F TC=0+-100	24546	C4-1/8-T0-393R-F
A9R33	0698-3439	4	0	RESISTOR 178 1% .125W F TC=0+-100	24546	C4-1/8-T0-178R-F
A9R34	0757-0417	0	8	RESISTOR 562 1% .125W F TC=0+-100	24546	C4-1/8-T0-562R-F
A9R35	0757-0401	0	0	RESISTOR 100 1% .125W F TC=0+-100	24546	C4-1/8-T0-101-F
A9R36	0683-4715	0	1	RESISTOR 470 5% .25W FC TC=-400/+600	01121	C84715
A9R37	0683-3315	4	0	RESISTOR 330 5% .25W FC TC=-400/+600	01121	C83315
A9R38	0683-2215	1	0	RESISTOR 220 5% .25W FC TC=-400/+600	01121	C82215
A9R39	1810-0203	5	0	NETWORK RES 8-SIP470.0 OHM X 7	01121	208A471
A9R40	0757-0401	0	0	RESISTOR 100 1% .125W F TC=0+-100	24546	C4-1/8-T0-101-F
A9R41	0698-3440	7	0	RESISTOR 196 1% .125W F TC=0+-100	24546	C4-1/8-T0-196R-F
A9R42	0757-0277	0	8	RESISTOR 49.9 1% .125W F TC=0+-100	24546	C4-1/8-T0-4992-F
A9R43	0698-3440	7	0	RESISTOR 196 1% .125W F TC=0+-100	24546	C4-1/8-T0-196R-F
A9R44	0698-3447	4	1	RESISTOR 422 1% .125W F TC=0+-100	24546	C4-1/8-T0-42R2-F
A9R45	0698-3153	9	0	RESISTOR 3.83K 1% .125W F TC=0+-100	24546	C4-1/8-T0-3831-F
A9R46	0757-0274	5	0	RESISTOR 1.21K 1% .125W F TC=0+-100	24546	C4-1/8-T0-1211-F
A9R47	0757-0316	6	0	RESISTOR 42.2 1% .125W F TC=0+-100	24546	C4-1/8-T0-42R2-F
A9R48	0757-0405	4	0	RESISTOR 162 1% .125W F TC=0+-100	24546	C4-1/8-T0-162R-F
A9R49	0757-0277	0	8	RESISTOR 49.9 1% .125W F TC=0+-100	24546	C4-1/8-T0-4992-F
A9R50	0757-0346	2	1	RESISTOR 10 1% .125W F TC=0+-100	24546	C4-1/8-T0-10R0-F
A9R51	0757-0401	0	0	RESISTOR 100 1% .125W F TC=0+-100	24546	C4-1/8-T0-101-F
A9R52	0757-0417	0	8	RESISTOR 562 1% .125W F TC=0+-100	24546	C4-1/8-T0-562R-F
A9U1	1820-0810	1	2	IC DLVR ECL LINE RCVR TPL 2-INP	04713	MC10116P
A9U2	1820-1888	5	1	IC PRESOR ECL	04713	MC12013L
A9U3	1820-0310	1	1	IC RCVR ECL LINE RCVR TPL 2-INP	04713	MC10116P
	5001-0176	7	2	STRAP-GROUND	28480	5001-0176
	04191-00614	6	1	SHIELD	28480	04191-00614
	04193-00604	6	2	SHIELD BOX	28480	04193-00604
	04193-00607	9	1	SHIELD IOX	28480	04193-00607
	04193-00608	0	2	SHIELD BOX	28480	04193-00608
	04193-60309	1	1	COVER	28480	04193-60309
	04193-26509	0	1	PCBD BLANK	28480	04193-26509

See introduction to this section for ordering information
 *Indicates factory selected value

Table 6-3. Replaceable Parts

Reference Designation	HP Part Number	C D	Qty	Description	Mfr Code	Mfr Part Number
A10						
A10	04193-66516	1	1	VOLTAGE CONTROLLED OSCILLATOR DEL. ASSY	28480	64193-66516
A10C1	0160-2437	1	3	CAPACITOR-FDTHRU 5000PF +30% -20% 260V	28480	0160-2437
A10C2	0160-2437	1		CAPACITOR-FDTHRU 5000PF +30% -20% 230V	28480	0160-2437
A10C3	0160-2437	1		CAPACITOR-FDTHRU 5000PF +30% -20% 260V	28480	0160-2437
A10C4	0160-3879	7	47	CAPACITOR-FXD .01UF +20% 100VDC CER	28480	0160-3879
A10C5	0160-3879	7		CAPACITOR-FXD .01UF +20% 100VDC CER	28480	0160-3879
A10C6	0160-3878	6	12	CAPACITOR-FXD 1000PF +-20 100VDC CER	28480	0160-3878
A10C7	0160-3879	7		CAPACITOR-FXD .01UF +20% 100VDC CER	28480	0160-3879
A10C8	0160-3879	7		CAPACITOR-FXD .01UF +20% 100VDC CER	28480	0160-3879
A10C9	0160-3878	6		CAPACITOR-FXD 1000PF +-20% 100VDC CER	28480	0160-3878
A10C10	0160-3879	7		CAPACITOR-FXD .01UF +20% 100VDC CER	28480	0160-3879
A10C11	0160-3879	7		CAPACITOR-FXD .01UF +20% 100VDC CER	28480	0160-3879
A10C12	0160-3879	7		CAPACITOR-FXD .01UF +20% 100VDC CER	28480	0160-3879
A10C13	0160-3878	6		CAPACITOR-FXD 1000PF +-20% 100VDC CER	28480	0160-3878
A10C14	0160-3879	7		CAPACITOR-FXD .01UF +20% 100VDC CER	28480	0160-3879
A10C15	0160-3879	7		CAPACITOR-FXD .01UF +20% 100VDC CER	28480	0160-3879
A10C16	0160-3878	6		CAPACITOR-FXD 1000PF +-20% 100VDC CER	28480	0160-3878
A10C17	0160-3879	7		CAPACITOR-FXD .01UF +20% 100VDC CER	28480	0160-3879
A10C18	0160-3879	7		CAPACITOR-FXD .01UF +20% 100VDC CER	28480	0160-3879
A10C19	0160-3879	7		CAPACITOR-FXD .01UF +20% 100VDC CER	28480	0160-3879
A10C20	0160-3879	7		CAPACITOR-FXD .01UF +20% 100VDC CER	28480	0160-3879
A10C21	0160-3879	7		CAPACITOR-FXD .01UF +20% 100VDC CER	28480	0160-3879
A10C22	0160-3879	7		CAPACITOR-FXD .01UF +20% 100VDC CER	28480	0160-3879
A10C23	0160-3877	5	5	CAPACITOR-FXD 100PF +-20% 200VDC CER	28480	0160-3877
A10C24	0160-3878	6		CAPACITOR-FXD 1000PF +-20% 100VDC CER	28480	0160-3878
A10C25	0160-3879	7		CAPACITOR-FXD .01UF +20% 100VDC CER	28480	0160-3879
A10C26	0160-3878	6		CAPACITOR-FXD 1000PF +-20% 100VDC CER	28480	0160-3878
A10C27	0160-3879	7		CAPACITOR-FXD .01UF +20% 100VDC CER	28480	0160-3879
A10C28	0160-3879	7		CAPACITOR-FXD .01UF +20% 100VDC CER	28480	0160-3879
A10C29	0160-3879	7		CAPACITOR-FXD .01UF +20% 100VDC CER	28480	0160-3879
A10C30	0160-3879	7		CAPACITOR-FXD .01UF +20% 100VDC CER	28480	0160-3879
A10C31	0160-5495	2	2	CAPACITOR-FXD 3.9PF +- .5PF 200VDC CER	28480	0160-3879
A10C32	0160-3879	7		CAPACITOR-FXD .01UF +20% 100VDC CER	28480	0160-3879
A10C33	0160-3879	7		CAPACITOR-FXD .01UF +20% 100VDC CER	28480	0160-3879
A10C34	0160-3878	6		CAPACITOR-FXD 1000PF +-20% 100VDC CER	28480	0160-3878
A10C35	0160-3879	7		CAPACITOR-FXD .01UF +20% 100VDC CER	28480	0160-3879
A10C36	0160-3879	7		CAPACITOR-FXD .01UF +20% 100VDC CER	28480	0160-3879
A10C37	0160-3878	6		CAPACITOR-FXD 1000PF +-20% 100VDC CER	28480	0160-3878
A10C38	0160-3879	7		CAPACITOR-FXD .01UF +20% 100VDC CER	28480	0160-3879
A10C39	0180-1083	3	1	CAPACITOR-FXD 3.9PF 250VDC AL	28480	0180-1083
A10C40	0160-3879	7		CAPACITOR-FXD .01UF +20% 100VDC CER	28480	0160-3879
A10C41	0160-3879	7		CAPACITOR-FXD .01UF +20% 100VDC CER	28480	0160-3879
A10C42	0160-3879	7		CAPACITOR-FXD .01UF +20% 100VDC CER	28480	0160-3879
A10C43	0160-3879	7		CAPACITOR-FXD .01UF +20% 100VDC CER	28480	0160-3879
A10C44	0160-5495	2		CAPACITOR-FXD 3.9PF +- .5PF 200VDC CER	28480	0160-3879
A10C45	0160-3877	5		CAPACITOR-FXD 100PF +-20% 200VDC CER	28480	0160-3877
A10C46	0160-3879	7		CAPACITOR-FXD .01UF +20% 100VDC CER	28480	0160-3879
A10C47	0160-3879	7		CAPACITOR-FXD .01UF +20% 100VDC CER	28480	0160-3879
A10C48	0160-3879	7		CAPACITOR-FXD .01UF +20% 100VDC CER	28480	0160-3879
A10C49	0160-3879	7		CAPACITOR-FXD .01UF +20% 100VDC CER	28480	0160-3879
A10C50	0160-3879	7		CAPACITOR-FXD .01UF +20% 100VDC CER	28480	0160-3879
A10C51	0160-3879	7		CAPACITOR-FXD .01UF +20% 100VDC CER	28480	0160-3879
A10C52	0160-3879	7		CAPACITOR-FXD .01UF +20% 100VDC CER	28480	0160-3879
A10C53	0180-2979	8	2	CAPACITOR-FXD 2200PF +-20% 16VDC AL	28480	0180-2979
A10C54	0180-2979	8		CAPACITOR-FXD 2200PF +-20% 16VDC AL	28480	0180-2979
A10C55	0160-3879	7		CAPACITOR-FXD .01UF +20% 100VDC CER	28480	0160-3879
A10C56	0160-3879	7		CAPACITOR-FXD .01UF +20% 100VDC CER	28480	0160-3879
A10C57	0160-3877	5		CAPACITOR-FXD 100PF +-20% 200VDC CER	28480	0160-3877
A10C58	0160-3877	5		CAPACITOR-FXD 100PF +-20% 200VDC CER	28480	0160-3877
A10C59	0160-3879	7		CAPACITOR-FXD .01UF +20% 100VDC CER	28480	0160-3879
A10C60	0160-3878	6		CAPACITOR-FXD 1000PF +-20% 100VDC CER	28480	0160-3878
A10C61	0160-3878	6		CAPACITOR-FXD 1000PF +-20% 100VDC CER	28480	0160-3878
A10C62	0160-3878	6		CAPACITOR-FXD 1000PF +-20% 100VDC CER	28480	0160-3878
A10C63	0160-3879	7		CAPACITOR-FXD .01UF +20% 100VDC CER	28480	0160-3879
A10C64	0160-3879	7		CAPACITOR-FXD .01UF +20% 100VDC CER	28480	0160-3879
A10C65	0160-3879	7		CAPACITOR-FXD .01UF +20% 100VDC CER	28480	0160-3879
A10C66	0160-2055	9	4	CAPACITOR-FXD .01UF +30% 20% 100VDC CER	28480	0160-2055
A10C67	0160-2055	9		CAPACITOR-FXD .01UF +30% 20% 100VDC CER	28480	0160-2055
A10C68	0160-2055	9		CAPACITOR-FXD .01UF +30% 20% 100VDC CER	28480	0160-2055
A10C69 *	0160-3873	1	1	CAPACITOR-FXD 4.70PF +- .5PF 200VDC CER	28480	0160-3873
A10C70	0160-4385	2	1	CAPACITOR-FXD 15PF +-5 200VDC CER 0+-30	51642	200-200-NP0-150J
A10C71	0160-2055	9		CAPACITOR-FXD .01UF +30% 20% 100VDC CER	28480	0160-2055
A10C72	0160-3690	4	1	CAPACITOR-FXD 1PF +- .5PF 100VDC CER	28480	0160-3690
A10C73	0160-3872	0	1	CAPACITOR-FXD 2.20PF +- .25PF 200VDC CER	28480	0160-3872
A10C74	0160-3878	6		CAPACITOR-FXD 1000PF +-20% 100VDC CER	28480	0160-3878

See introduction to this section for ordering information
 *Indicates factory selected value

PERFORMANCE TEST RECORD

Hewlett-Packard Model 4193A Vector Impedance Meter Serial No. _____		Tested by _____ Date _____																																																																																																																											
Paragraph Number	Test	Minimum	Actual Results	Maximum																																																																																																																									
4-9	INITIAL OPERATION CHECK DISPLAY TEST result (Pass/Fail) _____ SELF TEST result (Pass/Fail) _____ INITIAL CONTROL SETTINGS result (Pass/Fail) _____																																																																																																																												
4-10	TEST FREQUENCY ACCURACY CHECK Frequency Setting: <table style="margin-left: 20px; border: none;"> <tr><td>.400 MHz</td><td>0.399960 MHz</td><td>_____</td><td>0.400040 MHz</td></tr> <tr><td>9.999 MHz</td><td>9.99800 MHz</td><td>_____</td><td>9.99999 MHz</td></tr> <tr><td>10.00 MHz</td><td>9.99900 MHz</td><td>_____</td><td>10.0010 MHz</td></tr> <tr><td>39.99 MHz</td><td>39.9860 MHz</td><td>_____</td><td>39.9939 MHz</td></tr> <tr><td>40.00 MHz</td><td>39.9960 MHz</td><td>_____</td><td>40.0040 MHz</td></tr> <tr><td>69.99 MHz</td><td>69.9830 MHz</td><td>_____</td><td>69.9969 MHz</td></tr> <tr><td>70.00 MHz</td><td>69.9930 MHz</td><td>_____</td><td>70.0070 MHz</td></tr> <tr><td>110.0 MHz</td><td>109.989 MHz</td><td>_____</td><td>110.011 MHz</td></tr> </table>	.400 MHz	0.399960 MHz	_____	0.400040 MHz	9.999 MHz	9.99800 MHz	_____	9.99999 MHz	10.00 MHz	9.99900 MHz	_____	10.0010 MHz	39.99 MHz	39.9860 MHz	_____	39.9939 MHz	40.00 MHz	39.9960 MHz	_____	40.0040 MHz	69.99 MHz	69.9830 MHz	_____	69.9969 MHz	70.00 MHz	69.9930 MHz	_____	70.0070 MHz	110.0 MHz	109.989 MHz	_____	110.011 MHz																																																																																												
.400 MHz	0.399960 MHz	_____	0.400040 MHz																																																																																																																										
9.999 MHz	9.99800 MHz	_____	9.99999 MHz																																																																																																																										
10.00 MHz	9.99900 MHz	_____	10.0010 MHz																																																																																																																										
39.99 MHz	39.9860 MHz	_____	39.9939 MHz																																																																																																																										
40.00 MHz	39.9960 MHz	_____	40.0040 MHz																																																																																																																										
69.99 MHz	69.9830 MHz	_____	69.9969 MHz																																																																																																																										
70.00 MHz	69.9930 MHz	_____	70.0070 MHz																																																																																																																										
110.0 MHz	109.989 MHz	_____	110.011 MHz																																																																																																																										
4-11																																																																																																																													
4-12	IMPEDANCE ACCURACY TEST 10Ω range: 10Ω standard (____Ω, ____mH) Frequency Setting: <table style="margin-left: 20px; border: none;"> <tr><td>0.4MHz</td><td>Magnitude</td><td>_____ Ω</td><td>C.V. -84 counts</td><td>_____ Ω</td><td>C.V. +84 counts</td></tr> <tr><td></td><td>Phase</td><td>_____ °</td><td>C.V. -62 counts</td><td>_____ °</td><td>C.V. +62 counts</td></tr> <tr><td>1 MHz</td><td>Magnitude</td><td>_____ Ω</td><td>C.V. -72 counts</td><td>_____ Ω</td><td>C.V. +72 counts</td></tr> <tr><td></td><td>Phase</td><td>_____ °</td><td>C.V. -35 counts</td><td>_____ °</td><td>C.V. +35 counts</td></tr> <tr><td>10 MHz</td><td>Magnitude</td><td>_____ Ω</td><td>C.V. -72 counts</td><td>_____ Ω</td><td>C.V. +72 counts</td></tr> <tr><td></td><td>Phase</td><td>_____ °</td><td>C.V. -53 counts</td><td>_____ °</td><td>C.V. +53 counts</td></tr> <tr><td>40 MHz</td><td>Magnitude</td><td>_____ Ω</td><td>C.V. 138 counts</td><td>_____ Ω</td><td>C.V. +138 counts</td></tr> <tr><td></td><td>Phase</td><td>_____ °</td><td>C.V. -133 counts</td><td>_____ °</td><td>C.V. +133 counts</td></tr> <tr><td>110 MHz</td><td>Magnitude</td><td>_____ Ω</td><td>C.V. -329 counts</td><td>_____ Ω</td><td>C.V. +329 counts</td></tr> <tr><td></td><td>Phase</td><td>_____ °</td><td>C.V. -253 counts</td><td>_____ °</td><td>C.V. +253 counts</td></tr> </table> 100Ω range: 100Ω standard (____Ω, ____pF) Frequency Setting: <table style="margin-left: 20px; border: none;"> <tr><td>0.4MHz</td><td>Magnitude</td><td>_____ Ω</td><td>C.V. -42 counts</td><td>_____ Ω</td><td>C.V. +42 counts</td></tr> <tr><td></td><td>Phase</td><td>_____ °</td><td>C.V. -62 counts</td><td>_____ °</td><td>C.V. +62 counts</td></tr> <tr><td>1 MHz</td><td>Magnitude</td><td>_____ Ω</td><td>C.V. -34 counts</td><td>_____ Ω</td><td>C.V. +34 counts</td></tr> <tr><td></td><td>Phase</td><td>_____ °</td><td>C.V. -34 counts</td><td>_____ °</td><td>C.V. +34 counts</td></tr> <tr><td>10 MHz</td><td>Magnitude</td><td>_____ Ω</td><td>C.V. -34 counts</td><td>_____ Ω</td><td>C.V. +34 counts</td></tr> <tr><td></td><td>Phase</td><td>_____ °</td><td>C.V. -36 counts</td><td>_____ °</td><td>C.V. +36 counts</td></tr> <tr><td>40 MHz</td><td>Magnitude</td><td>_____ Ω</td><td>C.V. -44 counts</td><td>_____ Ω</td><td>C.V. +44 counts</td></tr> <tr><td></td><td>Phase</td><td>_____ °</td><td>C.V. -47 counts</td><td>_____ °</td><td>C.V. +47 counts</td></tr> <tr><td>110 MHz</td><td>Magnitude</td><td>_____ Ω</td><td>C.V. -71 counts</td><td>_____ Ω</td><td>C.V. +71 counts</td></tr> <tr><td></td><td>Phase</td><td>_____ °</td><td>C.V. -71 counts</td><td>_____ °</td><td>C.V. +71 counts</td></tr> </table>	0.4MHz	Magnitude	_____ Ω	C.V. -84 counts	_____ Ω	C.V. +84 counts		Phase	_____ °	C.V. -62 counts	_____ °	C.V. +62 counts	1 MHz	Magnitude	_____ Ω	C.V. -72 counts	_____ Ω	C.V. +72 counts		Phase	_____ °	C.V. -35 counts	_____ °	C.V. +35 counts	10 MHz	Magnitude	_____ Ω	C.V. -72 counts	_____ Ω	C.V. +72 counts		Phase	_____ °	C.V. -53 counts	_____ °	C.V. +53 counts	40 MHz	Magnitude	_____ Ω	C.V. 138 counts	_____ Ω	C.V. +138 counts		Phase	_____ °	C.V. -133 counts	_____ °	C.V. +133 counts	110 MHz	Magnitude	_____ Ω	C.V. -329 counts	_____ Ω	C.V. +329 counts		Phase	_____ °	C.V. -253 counts	_____ °	C.V. +253 counts	0.4MHz	Magnitude	_____ Ω	C.V. -42 counts	_____ Ω	C.V. +42 counts		Phase	_____ °	C.V. -62 counts	_____ °	C.V. +62 counts	1 MHz	Magnitude	_____ Ω	C.V. -34 counts	_____ Ω	C.V. +34 counts		Phase	_____ °	C.V. -34 counts	_____ °	C.V. +34 counts	10 MHz	Magnitude	_____ Ω	C.V. -34 counts	_____ Ω	C.V. +34 counts		Phase	_____ °	C.V. -36 counts	_____ °	C.V. +36 counts	40 MHz	Magnitude	_____ Ω	C.V. -44 counts	_____ Ω	C.V. +44 counts		Phase	_____ °	C.V. -47 counts	_____ °	C.V. +47 counts	110 MHz	Magnitude	_____ Ω	C.V. -71 counts	_____ Ω	C.V. +71 counts		Phase	_____ °	C.V. -71 counts	_____ °	C.V. +71 counts	Calibrated Value	Minimum	Actual Results	Maximum
0.4MHz	Magnitude	_____ Ω	C.V. -84 counts	_____ Ω	C.V. +84 counts																																																																																																																								
	Phase	_____ °	C.V. -62 counts	_____ °	C.V. +62 counts																																																																																																																								
1 MHz	Magnitude	_____ Ω	C.V. -72 counts	_____ Ω	C.V. +72 counts																																																																																																																								
	Phase	_____ °	C.V. -35 counts	_____ °	C.V. +35 counts																																																																																																																								
10 MHz	Magnitude	_____ Ω	C.V. -72 counts	_____ Ω	C.V. +72 counts																																																																																																																								
	Phase	_____ °	C.V. -53 counts	_____ °	C.V. +53 counts																																																																																																																								
40 MHz	Magnitude	_____ Ω	C.V. 138 counts	_____ Ω	C.V. +138 counts																																																																																																																								
	Phase	_____ °	C.V. -133 counts	_____ °	C.V. +133 counts																																																																																																																								
110 MHz	Magnitude	_____ Ω	C.V. -329 counts	_____ Ω	C.V. +329 counts																																																																																																																								
	Phase	_____ °	C.V. -253 counts	_____ °	C.V. +253 counts																																																																																																																								
0.4MHz	Magnitude	_____ Ω	C.V. -42 counts	_____ Ω	C.V. +42 counts																																																																																																																								
	Phase	_____ °	C.V. -62 counts	_____ °	C.V. +62 counts																																																																																																																								
1 MHz	Magnitude	_____ Ω	C.V. -34 counts	_____ Ω	C.V. +34 counts																																																																																																																								
	Phase	_____ °	C.V. -34 counts	_____ °	C.V. +34 counts																																																																																																																								
10 MHz	Magnitude	_____ Ω	C.V. -34 counts	_____ Ω	C.V. +34 counts																																																																																																																								
	Phase	_____ °	C.V. -36 counts	_____ °	C.V. +36 counts																																																																																																																								
40 MHz	Magnitude	_____ Ω	C.V. -44 counts	_____ Ω	C.V. +44 counts																																																																																																																								
	Phase	_____ °	C.V. -47 counts	_____ °	C.V. +47 counts																																																																																																																								
110 MHz	Magnitude	_____ Ω	C.V. -71 counts	_____ Ω	C.V. +71 counts																																																																																																																								
	Phase	_____ °	C.V. -71 counts	_____ °	C.V. +71 counts																																																																																																																								

PERFORMANCE TEST RECORD

Paragraph Number	Test	Calibrated Value	Minimum	Actual Results	Maximum
	<p>1kΩ range: 1kΩ standard (____ Ω, ____ pF)</p> <p>Frequency Setting:</p> <p>0.4MHz Magnitude _____ Ω C.V. -50 counts _____ Ω C.V. +50 counts</p> <p>Phase _____ ° C.V. -61 counts _____ ° C.V. +61 counts</p> <p>1 MHz Magnitude _____ Ω C.V. -41 counts _____ Ω C.V. +41 counts</p> <p>Phase _____ ° C.V. -34 counts _____ ° C.V. +34 counts</p> <p>10 MHz Magnitude _____ Ω C.V. -41 counts _____ Ω C.V. +41 counts</p> <p>Phase _____ ° C.V. -44 counts _____ ° C.V. +44 counts</p> <p>40 MHz Magnitude _____ Ω C.V. -72 counts _____ Ω C.V. +72 counts</p> <p>Phase _____ ° C.V. -77 counts _____ ° C.V. +77 counts</p> <p>110 MHz Magnitude _____ Ω C.V. -122 counts _____ Ω C.V. +122 counts</p> <p>Phase _____ ° C.V. -154 counts _____ ° C.V. +154 counts</p> <p>10kΩ range: 10kΩ standard (____ Ω, ____ pF)</p> <p>Frequency Setting:</p> <p>0.4MHz Magnitude _____ Ω C.V. -47 counts _____ Ω C.V. +47 counts</p> <p>Phase _____ ° C.V. -65 counts _____ ° C.V. +65 counts</p> <p>1 MHz Magnitude _____ Ω C.V. -38 counts _____ Ω C.V. +38 counts</p> <p>Phase _____ ° C.V. -36 counts _____ ° C.V. +36 counts</p> <p>10 MHz Magnitude _____ Ω C.V. -46 counts _____ Ω C.V. +46 counts</p> <p>Phase _____ ° C.V. -84 counts _____ ° C.V. +84 counts</p> <p>40 MHz Magnitude _____ Ω C.V. -77 counts _____ Ω C.V. +77 counts</p> <p>Phase _____ ° C.V. -87 counts _____ ° C.V. +87 counts</p> <p>100kΩ range: 5pF standard (____ pF)</p> <p>Frequency Setting:</p> <p>0.4MHz Magnitude _____ Ω C.V. -7 counts _____ Ω C.V. +7 counts</p> <p>Phase _____ ° C.V. -3 counts _____ ° C.V. +3 counts</p> <p>1 MHz Magnitude _____ Ω C.V. -5 counts _____ Ω C.V. +5 counts</p> <p>Phase _____ ° C.V. -4 counts _____ ° C.V. +4 counts</p>				
4-13	EXTERNAL OSCILLATOR USAGE CHECK				
	Test result (Pass/Fail)			_____	
4-14	RECORDER-OUTPUT VOLTAGE ACCURACY TEST				
	MAGNITUDE RECORDER-OUTPUT				
	Lower Left (↓ LL)		-20mV	_____	+20mV
	Upper Right (UR →)		+970mV	_____	+1030mV
	PHASE RECORDER-OUTPUT				
	Lower Left (↓ LL)		-20mV	_____	+20mV
	Upper Right (UR →)		+970mV	_____	+1030mV
	FREQUENCY RECORDER-OUTPUT				
	Lower Left (↓ LL)		-20mV	_____	+20mV
	Upper Right (UR →)		+970mV	_____	+1030mV
4-15	HP-IB INTERFACE TEST				
	REMOTE/LOCAL TEST result (Pass/Fail)			_____	
	LISTEN/TALK TEST result (Pass/Fail)			_____	
	DATA OUTPUT TEST result (Pass/Fail)			_____	
	COMPLETE DATA OUTPUT TEST result (Pass/Fail)			_____	
	SRQ TEST result (Pass/Fail)			_____	

PERFORMANCE TEST RECORD

Graph ber	Test	Calibrated Value	Minimum	Actual Results	Maximum
	<p>1kΩ range: 1kΩ standard (____ Ω, ____ pF)</p> <p>Frequency Setting:</p> <p>0.4MHz Magnitude Phase</p> <p>1 MHz Magnitude Phase</p> <p>10 MHz Magnitude Phase</p> <p>40 MHz Magnitude Phase</p> <p>110 MHz Magnitude Phase</p>	<p>_____ Ω</p> <p>_____ \circ</p> <p>_____ Ω</p> <p>_____ \circ</p> <p>_____ Ω</p> <p>_____ \circ</p> <p>_____ Ω</p> <p>_____ \circ</p> <p>_____ Ω</p> <p>_____ \circ</p>	<p>C.V. -50 counts</p> <p>C.V. -61 counts</p> <p>C.V. -41 counts</p> <p>C.V. -34 counts</p> <p>C.V. -41 counts</p> <p>C.V. -44 counts</p> <p>C.V. -72 counts</p> <p>C.V. -77 counts</p> <p>C.V. -122 counts</p> <p>C.V. -154 counts</p>	<p><u>7111</u> Ω</p> <p><u>-2.5</u> \circ</p> <p><u>748</u> Ω</p> <p><u>-1.7</u> \circ</p> <p><u>1077</u> Ω</p> <p><u>11.0</u> \circ</p> <p><u>95.0</u> Ω</p> <p><u>-24.0</u> \circ</p> <p><u>74.5</u> Ω</p> <p><u>-2.3</u> \circ</p>	<p>C.V. +50 counts</p> <p>C.V. +61 counts</p> <p>C.V. +41 counts</p> <p>C.V. +34 counts</p> <p>C.V. +41 counts</p> <p>C.V. +44 counts</p> <p>C.V. +72 counts</p> <p>C.V. +77 counts</p> <p>C.V. +122 counts</p> <p>C.V. +154 counts</p>
	<p>10kΩ range: 10kΩ standard (____ Ω, ____ pF)</p> <p>Frequency Setting:</p> <p>0.4MHz Magnitude Phase</p> <p>1 MHz Magnitude Phase</p> <p>10 MHz Magnitude Phase</p> <p>40 MHz Magnitude Phase</p>	<p>_____ Ω</p> <p>_____ \circ</p> <p>_____ Ω</p> <p>_____ \circ</p> <p>_____ Ω</p> <p>_____ \circ</p> <p>_____ Ω</p> <p>_____ \circ</p>	<p>C.V. -47 counts</p> <p>C.V. -65 counts</p> <p>C.V. -38 counts</p> <p>C.V. -36 counts</p> <p>C.V. -46 counts</p> <p>C.V. -84 counts</p> <p>C.V. -77 counts</p> <p>C.V. -87 counts</p>	<p><u>1.50 k</u> Ω</p> <p><u>-1.1</u> \circ</p> <p><u>6.91</u> Ω</p> <p><u>-2.0</u> \circ</p> <p><u>5.83</u> Ω</p> <p><u>-4.8</u> \circ</p> <p><u>37.9</u> Ω</p> <p><u>-1.17</u> \circ</p>	<p>C.V. +47 counts</p> <p>C.V. +65 counts</p> <p>C.V. +38 counts</p> <p>C.V. +36 counts</p> <p>C.V. +46 counts</p> <p>C.V. +84 counts</p> <p>C.V. +77 counts</p> <p>C.V. +87 counts</p>
	<p>100kΩ range: 5pF standard (____ pF)</p> <p>Frequency Setting:</p> <p>0.4MHz Magnitude Phase</p> <p>1 MHz Magnitude Phase</p>	<p>_____ Ω</p> <p>_____ \circ</p> <p>_____ Ω</p> <p>_____ \circ</p>	<p>C.V. -7 counts</p> <p>C.V. -3 counts</p> <p>C.V. -5 counts</p> <p>C.V. -4 counts</p>	<p><u>35.0 k</u> Ω</p> <p><u>-80.0</u> \circ</p> <p><u>23.5</u> Ω</p> <p><u>-90.0</u> \circ</p>	<p>C.V. +7 counts</p> <p>C.V. +3 counts</p> <p>C.V. +5 counts</p> <p>C.V. +4 counts</p>
5	EXTERNAL OSCILLATOR USAGE CHECK				
	Test result (Pass/Fail)			_____	
4	RECORDER-OUTPUT VOLTAGE ACCURACY TEST				
	MAGNITUDE RECORDER-OUTPUT				
	Lower Left (\downarrow LL)		-20mV	_____	+20mV
	Upper Right (UR \rightarrow)		+970mV	_____	+1030mV
	PHASE RECORDER-OUTPUT				
	Lower Left (\downarrow LL)		-20mV	_____	+20mV
	Upper Right (UR \rightarrow)		+970mV	_____	+1030mV
	FREQUENCY RECORDER-OUTPUT				
	Lower Left (\downarrow LL)		-20mV	_____	+20mV
	Upper Right (UR \rightarrow)		+970mV	_____	+1030mV
5	HP-IB INTERFACE TEST				
	REMOTE/LOCAL TEST result (Pass/Fail)			_____	
	LISTEN/TALK TEST result (Pass/Fail)			_____	
	DATA OUTPUT TEST result (Pass/Fail)			_____	
	COMPLETE DATA OUTPUT TEST result (Pass/Fail)			_____	
	SRQ TEST result (Pass/Fail)			_____	

PERFORMANCE TEST RECORD

Hewlett-Packard
Model 4193A
Vector Impedance Meter
Serial No. _____

Tested by _____
Date _____

Paragraph Number	Test	Minimum	Actual Results	Maximum	
4-9	INITIAL OPERATION CHECK DISPLAY TEST result (Pass/Fail) SELF TEST result (Pass/Fail) INITIAL CONTROL SETTINGS result (Pass/Fail)		_____ _____ _____		
4-10	TEST FREQUENCY ACCURACY CHECK Frequency Setting: .400 MHz 9.999 MHz 10.00 MHz 39.99 MHz 40.00 MHz 69.99 MHz 70.00 MHz 110.0 MHz	0.399960 MHz 9.99800 MHz 9.99900 MHz 39.9860 MHz 39.9960 MHz 69.9830 MHz 69.9930 MHz 109.989 MHz	_____ _____ _____ _____ _____ _____ _____ _____	0.400040 MHz 9.99999 MHz 10.0010 MHz 39.9939 MHz 40.0040 MHz 69.9969 MHz 70.0070 MHz 110.011 MHz	
4-11					
4-12	IMPEDANCE ACCURACY TEST 10Ω range: 10Ω standard (____Ω, ____mH) Frequency Setting: 0.4MHz Magnitude Phase 1 MHz Magnitude Phase 10 MHz Magnitude Phase 40 MHz Magnitude Phase 110 MHz Magnitude Phase 100Ω range: 100Ω standard (____Ω, ____pF) Frequency Setting: 0.4MHz Magnitude Phase 1 MHz Magnitude Phase 10 MHz Magnitude Phase 40 MHz Magnitude Phase 110 MHz Magnitude Phase	Calibrated Value ____Ω ____° ____Ω ____° ____Ω ____° ____Ω ____° ____Ω ____° ____Ω ____° ____Ω ____° ____Ω ____° ____Ω ____° ____Ω ____°	Minimum C.V. -84 counts C.V. -62 counts C.V. -72 counts C.V. -35 counts C.V. -72 counts C.V. -53 counts C.V. 138 counts C.V. -133 counts C.V. -329 counts C.V. -253 counts C.V. -42 counts C.V. -62 counts C.V. -34 counts C.V. -34 counts C.V. -34 counts C.V. -36 counts C.V. -44 counts C.V. -47 counts C.V. -71 counts C.V. -71 counts	Actual Results 2.78 Ω -2.1 ° 7.22 Ω 7.2 ° 7.15 Ω 25.4 ° 1.05 Ω -50.0 ° 8.77 Ω 9.12 ° 74.8 Ω -5.5 ° 75.2 Ω 1.3 ° 48.2 Ω 20.9 ° 1.73 Ω 128.6 ° 5.25 Ω 58.4 °	Maximum C.V. +84 counts C.V. +62 counts C.V. +72 counts C.V. +35 counts C.V. +72 counts C.V. +53 counts C.V. +138 counts C.V. +133 counts C.V. +329 counts C.V. +253 counts C.V. +42 counts C.V. +62 counts C.V. +34 counts C.V. +34 counts C.V. +34 counts C.V. +36 counts C.V. +44 counts C.V. +47 counts C.V. +71 counts C.V. +71 counts

Table 6-3. Replaceable Parts

Reference Designation	HP Part Number	C D	Qty	Description	Mfr Code	Mfr Part Number
A10C75	0160-3879	7		CAPACITOR-FXD .010UF +-20% 100VDC CER	28480	0160-3879
A10C76	0160-3877	5		CAPACITOR-FXD 100PF +-20% 200VDC CER	28480	0160-3877
A10C77	0160-3879	7		CAPACITOR-FXD .010UF +-20% 100VDC CER	28480	0160-3879
A10C78	0160-3879	7		CAPACITOR-FXD .010UF +-20% 100VDC CER	28480	0160-3879
A10C79	0160-3879	7		CAPACITOR-FXD .010UF +-20% 100VDC CER	28480	0160-3879
A10C80	0160-3879	7		CAPACITOR-FXD .010UF +-20% 100VDC CER	28480	0160-3879
A10CR1	1902-3171	7	1	DIODE ZNR 11V 5% DO-35 PD=1.4W TC=+0.062%	28480	1902-3171
A10CR2	1901-0948	8	3	DIODE-1S2222	28480	1901-0948
A10CR3	1901-0948	8		DIODE-1S2222	28480	1901-0948
A10CR4	1901-0948	8		DIODE-1S2222	28480	1901-0948
A10CR5	6122-0169	0	1	DIODE-VVC	28480	0122-0169
A10CR6	1901-0040	1	1	DIODE-SWITCHING 30V 50MA 2NS DO 35	28480	1901-0040
A10Q1	1054-0345	8	5	TRANSISTOR NPN 2N5179 SI TO-72 PD=200MW	04713	2N5179
A10Q2	1054-0345	8		TRANSISTOR NPN 2N5179 SI TO-72 PD=200MW	04713	2N5179
A10Q3	1054-0345	8		TRANSISTOR NPN 2N5179 SI TO-72 PD=200MW	04713	2N5179
A10Q4	1053-0459	3	1	TRANSISTOR PNP SI PD=625MW FT=200MHZ	28480	1053-0459
A10Q5	1054-0247	9	1	TRANSISTOR NPN SI TO-39 PD=1W FT=800MHZ	28480	1054-0247
A10Q6	1054-0345	8		TRANSISTOR NPN 2N5179 SI TO-72 PD=200MW	04713	2N5179
A10Q7	1054-0130	9	1	TRANSISTOR NPN 2SC1988	28480	1054-0130
A10Q8	1055-0124	3	1	TRANSISTOR-FET 3SK48	28480	1055-0124
A10Q9	1054-0345	8		TRANSISTOR NPN 2N5179 SI TO-72 PD=200MW	04713	2N5179
A10R1	0693-4715	0	1	RESISTOR 470 5% .25W FC TC=-400/+600	01121	CB4715
A10R2	0693-1025	9	0	RESISTOR 1K 5% .25W FC TC=-400/+600	01121	CB1025
A10R3	0757-0346	2	3	RESISTOR 10 1% .125W F TC=0+-100	24546	C4-1/8-T0-10R0-F
A10R4	0693-3437	2	1	RESISTOR 133 1% .125W F TC=0+-100	24546	C4-1/8-T0-133R-F
A10R5	0693-2215	1	1	RESISTOR 220 5% .25W FC TC=-400/+600	01121	CB2215
A10R6	0757-0277	8	4	RESISTOR 49.9 1% .125W F TC=0+-100	24546	C4-1/8-T0-4992-F
A10R7	0693-1625	9		RESISTOR 1K 5% .25W FC TC=-400/+600	01121	CB1625
A10R8	0757-0346	2		RESISTOR 10 1% .125W F TC=0+-100	24546	C4-1/8-T0-10R0-F
A10R9	0698-7205	0	4	RESISTOR 51.1 1% .05W F TC=0+-100	24546	C3-1/8-T00-51R1-G
A10R10	0757-0401	0	4	RESISTOR 100 1% .125W F TC=0+-100	24546	C4-1/8-T0-101-F
A10R11	0757-0401	0		RESISTOR 100 1% .125W F TC=0+-100	24546	C4-1/8-T0-101-F
A10R12	0757-0277	8		RESISTOR 49.9 1% .125W F TC=0+-100	24546	C4-1/8-T0-4992-F
A10R13	0693-1025	9		RESISTOR 1K 5% .25W FC TC=-400/+600	01121	CB1025
A10R14	0757-0346	2		RESISTOR 10 1% .125W F TC=0+-100	24546	C4-1/8-T0-10R0-F
A10R15	0757-0401	0		RESISTOR 100 1% .125W F TC=0+-100	24546	C4-1/8-T0-101-F
A10R16	0698-7205	0		RESISTOR 51.1 1% .05W F TC=0+-100	24546	C3-1/8-T00-51R1-G
A10R17	0757-0401	0		RESISTOR 100 1% .125W F TC=0+-100	24546	C4-1/8-T0-101-F
A10R18	0757-0277	8		RESISTOR 49.9 1% .125W F TC=0+-100	24546	C4-1/8-T0-4992-F
A10R19	0693-1025	9		RESISTOR 1K 5% .25W FC TC=-400/+600	01121	CB1025
A10R20	0693-3915	0	1	RESISTOR 390 5% .25W FC TC=-400/+600	01121	CB3915
A10R21	0693-3315	4	1	RESISTOR 330 5% .25W FC TC=-400/+600	01121	CB3315
A10R22	0693-4705	8	1	RESISTOR 47 5% .25W FC TC=-400/+500	01121	CB4705
A10R23	0757-0403	2	2	RESISTOR 121 1% .125W F TC=0+-100	24546	C4-1/8-T0-121R-F
A10R24	0757-0403	2		RESISTOR 121 1% .125W F TC=0+-100	24546	C4-1/8-T0-121R-F
A10R25	0693-0002	7	1	RESISTOR 464 1% .125W F TC=0+-100	24546	C4-1/8-T0-4646-F
A10R26	0757-0290	7	2	RESISTOR 5.62K 1% .125W F TC=0+-100	24546	C4-1/8-T0-5621-F
A10R27	0757-0428	1	2	RESISTOR 1.62K 1% .125W F TC=0+-100	24546	C4-1/8-T0-1621-F
A10R28	0698-7205	0		RESISTOR 51.1 1% .05W F TC=0+-100	24546	C3-1/8-T00-51R1-G
A10R29	0757-0416	7	1	RESISTOR 511 1% .125W F TC=0+-100	24546	C4-1/8-T0-511R-F
A10R30	0693-1025	9		RESISTOR 1K 5% .25W FC TC=-400/+600	01121	CB1025
A10R31	0693-1025	9		RESISTOR 1K 5% .25W FC TC=-400/+600	01121	CB1025
A10R32	0693-1025	9		RESISTOR 1K 5% .25W FC TC=-400/+600	01121	CB1025
A10R33	0693-1025	9		RESISTOR 1K 5% .25W FC TC=-400/+600	01121	CB1025
A10R34	0698-7205	0		RESISTOR 51.1 1% .05W F TC=0+-100	24546	C3-1/8-T00-51R1-G
A10R35	0757-1094	9	1	RESISTOR 1.47K 1% .125W F TC=0+-100	24546	C4-1/8-T0-1471-F
A10R36	0698-3154	0	1	RESISTOR 4.22K 1% .125W F TC=0+-100	24546	C4-1/8-T0-4221-F
A10R37	0693-0085	0	1	RESISTOR 2.61K 1% .125W F TC=0+-100	24546	C4-1/8-T0-2611-F
A10R38	0698-3155	1	1	RESISTOR 4.64K 1% .125W F TC=0+-100	24546	C4-1/8-T0-4641-F
A10R39	0757-0200	3	1	RESISTOR 1K 1% .125W F TC=0+-100	24546	C4-1/8-T0-1001-F
A10R40	0693-3305	2	1	RESISTOR 33 5% .25W FC TC=-400/+500	01121	CB3305
A10R41	0757-0277	8		RESISTOR 49.9 1% .125W F TC=0+-100	24546	C4-1/8-T0-4992-F
A10R42	0757-0417	8	1	RESISTOR 562 1% .125W F TC=0+-100	24546	C4-1/8-T0-562R-F
A10R43	0757-0420	1		RESISTOR 1.62K 1% .125W F TC=0+-100	24546	C4-1/8-T0-1621-F
A10R44	0757-0290	7		RESISTOR 5.62K 1% .125W F TC=0+-100	24546	C4-1/8-T0-5621-F
A10U1	1026-0693	8	1	IC FT TL S-P-TYPE POS-EDGE-TRIG	01295	SN74S74N
A10U2	1026-0004	5	1	IC PREFER FCL	04713	MC12013L
A10U3	1026-0372	2	3	IC 5GHZ TRANSISTOR PAIR	28480	1026-0372
A10U4	1026-0372	2		IC 5GHZ TRANSISTOR PAIR	28480	1026-0372
A10U5	1026-0372	2		IC 5GHZ TRANSISTOR PAIR	28480	1026-0372
	0300-1007	5	11	STANDARD RIVET ON	00000	ORDER BY DESCRIPTION
	5001-0176	7	2	STRAP CRD-IND	28480	5001-0173
	04191-00601	1	1	SHIELD BOX	28480	04191-00601
	04193-00604	6	3	SHIELD BOX	28480	04193-00604
	04193-00607	9	2	SHIELD BOX	28480	04193-00607

See introduction to this section for ordering information
 *Indicates factory selected value

Table 6-3. Replaceable Parts

Reference Designation	HP Part Number	C D	Qty	Description	Mfr Code	Mfr Part Number
	04193-20006	4	1	SHIELD-BOX	28480	04193-20006
	04193-60010	4	1	COVER	28480	04193-60010
	04193-26510	0	1	PCBD BLANK	28480	04193-26510

See introduction to this section for ordering information
 *Indicates factory selected value

Table 6-3. Replaceable Parts

Reference Designation	HP Part Number	C D	Qty	Description	Mfr Code	Mfr Part Number
A11						
A11	04193-66511	2	1	INTEGRATOR AMPLIFIER BOARD ASSEM	28480	04193-66511
A11C1	0180-1083	3	6	CAPACITOR-FXD 33UF 25VDC AL	28480	0180-1083
A11C2	0160-4832	4	5	CAPACITOR-FXD .01UF +-10% 100VDC CER	28480	0160-4832
A11C3	0180-1083	3	3	CAPACITOR-FXD 33UF 25VDC AL	28480	0180-1083
A11C4	0160-4835	7	9	CAPACITOR-FXD .1UF +-10% 50VDC CER	28480	0160-4835
A11C5	0160-4835	7	7	CAPACITOR-FXD .1UF +-10% 50VDC CER	28480	0160-4835
A11C6	0180-0228	6	2	CAPACITOR-FXD 22UF+-10% 15VDC TA	56289	150D226X9015B2
A11C7	0160-4835	7	4	CAPACITOR-FXD .1UF +-10% 50VDC CER	28480	0160-4835
A11C8	0160-4832	4	4	CAPACITOR-FXD .01UF +-10% 100VDC CER	28480	0160-4832
A11C9	0180-0116	1	3	CAPACITOR-FXD 6.8UF+-10% 35VDC TA	56289	150D68X9035B2
A11C10	0180-0228	6	6	CAPACITOR-FXD 22UF+-10% 15VDC TA	56289	150D226X9015B2
A11C11	0160-4835	7	7	CAPACITOR-FXD .1UF +-10% 50VDC CER	28480	0160-4835
A11C12	0160-4835	7	7	CAPACITOR-FXD .1UF +-10% 50VDC CER	28480	0160-4835
A11C13	0180-0116	1	1	CAPACITOR-FXD 6.8UF+-10% 35VDC TA	56289	150D68X9035B2
A11C14	0160-4835	7	7	CAPACITOR-FXD .1UF +-10% 50VDC CER	28480	0160-4835
A11C15	0180-0116	1	1	CAPACITOR-FXD 6.8UF+-10% 35VDC TA	56289	150D68X9035B2
A11C16	0160-4835	7	7	CAPACITOR-FXD .1UF +-10% 50VDC CER	28480	0160-4835
A11C17	0160-4835	7	7	CAPACITOR-FXD .1UF +-10% 50VDC CER	28480	0160-4835
A11C18	0160-3501	2	1	CAPACITOR-FXD 4UF +-10% 50VDC MET-POLYC	28480	0160-3501
A11C19	0180-1083	3	3	CAPACITOR-FXD 33UF 25VDC AL	28480	0180-1083
A11C20	0160-4832	4	4	CAPACITOR-FXD .01UF +-10% 100VDC CER	28480	0160-4832
A11C21	0160-4832	4	4	CAPACITOR-FXD .01UF +-10% 100VDC CER	28480	0160-4832
A11C22	0160-4832	4	4	CAPACITOR-FXD .01UF +-10% 100VDC CER	28480	0160-4832
A11C23	0180-1083	3	3	CAPACITOR-FXD 33UF 25VDC AL	28480	0180-1083
A11C24	0180-1083	3	3	CAPACITOR-FXD 33UF 25VDC AL	28480	0180-1083
A11C25	0180-1083	3	3	CAPACITOR-FXD 33UF 25VDC AL	28480	0180-1083
A11C26	0160-4835	7	7	CAPACITOR-FXD .1UF +-10% 50VDC CER	28480	0160-4835
A11CR1	1901-0040	1	6	DIODE-SWITCHING 30V 50MA 2NS DO-35	28480	1901-0040
A11CR2	1902-3165	9	1	DIODE-ZNR 10.5V 5% DO-35 PD=.4W	28480	1902-3165
A11CR3	1901-0040	1	1	DIODE-SWITCHING 30V 50MA 2NS DO-35	28480	1901-0040
A11CR4	1901-0040	1	1	DIODE-SWITCHING 30V 50MA 2NS DO-35	28480	1901-0040
A11CR5	1901-0040	1	1	DIODE-SWITCHING 30V 50MA 2NS DO-35	28480	1901-0040
A11CR6	1902-3263	8	1	DIODE-ZNR 24.9V 2% DO-35 PD=.4W	28480	1902-3263
A11CR7	1901-0040	1	1	DIODE-SWITCHING 30V 50MA 2NS DO-35	28480	1901-0040
A11CR8	1901-0040	1	1	DIODE-SWITCHING 30V 50MA 2NS DO-35	28480	1901-0040
A11J1	1251-4822	6	2	CONNECTOR 3-PIN M POST TYPE	28480	1251-4822
A11J2	1251-4822	6	6	CONNECTOR 3-PIN M POST TYPE	28480	1251-4822
A11L1	9140-0216	1	2	INDUCTOR RF-CHEMLD 100UH 5% .166DX.385LG	28480	9140-0216
A11L2	9140-0210	1	1	INDUCTOR RF-CHEMLD 100UH 5% .166DX.385LG	28480	9140-0210
A11L3	9140-0114	4	1	INDUCTOR RF-CHEMLD 10UH 10% .166DX.385LG	28480	9140-0114
A11Q1	1854-0810	2	5	TRANSISTOR NPN SI PD=625MW FT=200MHZ	28480	1854-0810
A11Q2	1854-0810	2	2	TRANSISTOR NPN SI PD=625MW FT=200MHZ	28480	1854-0810
A11Q3	1855-0111	8	2	TRANSISTOR FET 25K43SD	28480	1855-0111
A11Q4	1855-0111	8	8	TRANSISTOR FET 25K43SD	28480	1855-0111
A11Q5	1853-0459	3	5	TRANSISTOR PNP SI PD=625MW FT=200MHZ	28480	1853-0459
A11Q6	1853-0459	3	3	TRANSISTOR PNP SI PD=625MW FT=200MHZ	28480	1853-0459
A11Q7	1853-0459	3	3	TRANSISTOR PNP SI PD=625MW FT=200MHZ	28480	1853-0459
A11Q8	1853-0459	3	3	TRANSISTOR PNP SI PD=625MW FT=200MHZ	28480	1853-0459
A11Q9	1854-0810	2	2	TRANSISTOR NPN SI PD=625MW FT=200MHZ	28480	1854-0810
A11Q10	1854-0810	2	2	TRANSISTOR NPN SI PD=625MW FT=200MHZ	28480	1854-0810
A11Q11	1854-0810	2	2	TRANSISTOR NPN SI PD=625MW FT=200MHZ	28480	1854-0810
A11Q12	1853-0459	3	3	TRANSISTOR PNP SI PD=625MW FT=200MHZ	28480	1853-0459
A11R1*	0757-0288	1	2	RESISTOR 9.09K 1% .125W F TC=0+-100	19701	MF4C1/8-T0-9091-F
A11R2*	0757-0288	1	1	RESISTOR 9.09K 1% .125W F TC=0+-100	19701	MF4C1/8-T0-9091-F
A11R3	2100-3273	1	1	RESISTOR-TMR 2K 10% C 510E-ADJ 1-TRN	28480	2100-3273
A11R4	0698-3558	8	2	RESISTOR 4.02K 1% .125W F TC=0+-100	24546	C4-1/8-T0-4021-F
A11R5	0698-3459	6	2	RESISTOR 40.2K 1% .125W F TC=0+-100	24546	C4-1/8-T0-4022-F
A11R6	0693-1025	9	6	RESISTOR 1K 5% .25W FC TC=-400/+600	01121	CR1025
A11R7	0683-1025	9	9	RESISTOR 1K 5% .25W FC TC=-400/+600	01121	CR1025
A11R8	0693-1015	7	2	RESISTOR 100 5% .25W FC TC=-400/+500	01121	CR1015
A11R9	0698-3153	9	3	RESISTOR 3.83K 1% .125W F TC=0+-100	24546	C4-1/8-T0-3831-F
A11R10	0683-3305	2	3	RESISTOR 33 5% .25W FC TC=-400/+500	01121	CR3305
A11R11	0698-3447	4	1	RESISTOR 422 1% .125W F TC=0+-100	24546	C4-1/8-T0-422R-F
A11R12	0683-2225	3	2	RESISTOR 2.2K 5% .25W FC TC=-400/+700	01121	CR2225
A11R13	0683-2225	3	3	RESISTOR 2.2K 5% .25W FC TC=-400/+700	01121	CR2225
A11R14	0757-0288	3	3	RESISTOR 1K 1% .125W F TC=0+-100	24546	C4-1/8-T0-1001-F
A11R15	0683-3305	2	3	RESISTOR 33 5% .25W FC TC=-400/+500	01121	CR3305
A11R16	0698-0083	8	1	RESISTOR 1.96K 1% .125W F TC=0+-100	24546	C4-1/8-T0-1961-F
A11R17	0693-4725	2	9	RESISTOR 4.7K 5% .25W FC TC=-400/+700	01121	CR4725
A11R18	0683-4725	2	2	RESISTOR 4.7K 5% .25W FC TC=-400/+700	01121	CR4725
A11R19	0683-4725	2	2	RESISTOR 4.7K 5% .25W FC TC=-400/+700	01121	CR4725
A11R20	0693-1025	9	9	RESISTOR 1K 5% .25W FC TC=-400/+600	01121	CR1025

See introduction to this section for ordering information
 *Indicates factory selected value

Table 6-3. Replaceable Parts

Reference Designation	HP Part Number	C D	Qty	Description	Mfr Code	Mfr Part Number
A11R21	0683-1025	9		RESISTOR 1K 5% .25W FC TC=-400/+500	01121	CB1025
A11R22	0683-4705	8	1	RESISTOR 47 5% .25W FC TC=-400/+500	01121	CB4705
A11R23	0690-3550	8		RESISTOR 4.02K 1% .125W F TC=0+-100	24546	C4-1/8-T0-4021-F
A11R24	0757-0277	8	1	RESISTOR 49.9 1% .125W F TC=0+-100	24546	C4-1/8-T0-4922-F
A11R25	0683-1055	5	2	RESISTOR 10 5% .25W FC TC= 800/+250	01121	CB1055
A11R26	0683-1015	7		RESISTOR 100 5% .25W FC TC= 400/+500	01121	CB1015
A11R27	0690-3153	9		RESISTOR 3.03K 1% .125W F TC=0+-100	24546	C4-1/8-T0-3031-F
A11R28	0683-3305	2		RESISTOR 33 5% .25W FC TC=-400/+500	01121	CB3305
A11R29	0683-4725	2		RESISTOR 4.7K 5% .25W FC TC=-400/+200	01121	CB4725
A11R30	0683-4725	2		RESISTOR 4.7K 5% .25W FC TC=-400/+200	01121	CB4725
A11R31	0683-4725	2		RESISTOR 4.7K 5% .25W FC TC=-400/+200	01121	CB4725
A11R32	0683-1025	9		RESISTOR 1K 5% .25W FC TC=-400/+500	01121	CB1025
A11R33	0690-3444	1	1	RESISTOR 316 1% .125W F TC=0+-100	24546	C4-1/8-T0-316R-F
A11R34	0757-0280	3		RESISTOR 1K 1% .125W F TC=0+-100	24546	C4-1/8-T0-1001-F
A11R35	0690-3499	6		RESISTOR 40.2K 1% .125W F TC=0+-100	24546	C4-1/8-T0-4022-F
A11R36	0683-1025	9		RESISTOR 1K 5% .25W FC TC=-400/+500	01121	CB1025
A11R37	0757-0280	3		RESISTOR 1K 1% .125W F TC=0+-100	24546	C4-1/8-T0-1001-F
A11R38	0683-5625	3	8	RESISTOR 5.6K 5% .25W FC TC=-400/+200	01121	CB5625
A11R39	0683-5625	3		RESISTOR 5.6K 5% .25W FC TC=-400/+200	01121	CB5625
A11R40	0683-5625	3		RESISTOR 5.6K 5% .25W FC TC=-400/+200	01121	CB5625
A11R41	0683-5625	3		RESISTOR 5.6K 5% .25W FC TC=-400/+200	01121	CB5625
A11R42	0683-5625	3		RESISTOR 5.6K 5% .25W FC TC=-400/+200	01121	CB5625
A11R43	0683-5625	3		RESISTOR 5.6K 5% .25W FC TC=-400/+200	01121	CB5625
A11R44	0683-4725	2		RESISTOR 4.7K 5% .25W FC TC=-400/+200	01121	CB4725
A11R45	0683-4725	2		RESISTOR 4.7K 5% .25W FC TC=-400/+200	01121	CB4725
A11R46	0683-4725	2		RESISTOR 4.7K 5% .25W FC TC=-400/+200	01121	CB4725
A11R47	0690-3153	9		RESISTOR 3.03K 1% .125W F TC=0+-100	24546	C4-1/8-T0-3031-F
A11R48	0757-0274	5	1	RESISTOR 1.21K 1% .125W F TC=0+-100	24546	C4-1/8-T0-1211-F
A11R49	0683-1825	7	1	RESISTOR 1.8K 5% .25W FC TC= 400/+200	01121	CB1825
A11R50	0683-1035	1	2	RESISTOR 10K 5% .25W FC TC=-400/+200	01121	CB1035
A11R51	0683-1055	5		RESISTOR 10 5% .25W FC TC= 800/+250	01121	CB1055
A11R52	0683-5625	3		RESISTOR 5.6K 5% .25W FC TC=-400/+200	01121	CB5625
A11R53	0683-1835	1		RESISTOR 18K 5% .25W FC TC=-400/+200	01121	CB1835
A11R54	0683-5625	3		RESISTOR 5.6K 5% .25W FC TC=-400/+200	01121	CB5625
A11R55	0683-6805	3	1	RESISTOR 68 5% .25W FC TC= 400/+500	01121	CB6805
			1			
A11U1	1826-0266	3	1	IC OP AMP LOW-BRIFT 10-59 PKG	06665	OP-05EJ
A11U2	1820-1950	0	1	IC SWITCH AN/C QJAD 14-DIP-P PKG	01220	CG401600
A11U3	1826-0138	8	2	IC COMPARATOR CP QUAD 14-DIP-P PKG	01295	1M335N
A11U4	1820-1197	9	2	IC GATE TTL 1S NAND QJAD 2-IMP	01225	SN74LS00N
A11U5	1820-1418	7	1	IC OPER TTL 1S DED-TO-BED 4-10-10-119E	01295	SN74LS42N
A11U6	1826-0138	8		IC COMPARATOR CP QUAD 14-DIP-P PKG	01295	1M335N
A11U7	1820-1201	6	1	IC GATE TTL 1S AND QUAD 2-IMP	01295	SN74LS08N
A11U8	1820-1197	9		IC GATE TTL 1S NAND QUAD 2-IMP	01225	SN74LS00N
A11U9	1820-0630	3	1	IC MISC TTL	04713	PC404AP
A11U10	1820-1144	6	1	IC GATE TTL 1S NOR QUAD 2-IMP	01225	SN74LS02N
A11U11	1820-1238	3	1	IC GATE TTL 1S OR QUAD 2-IMP	01295	SN74LS32N
A11W1	8159-0005	8	4	WIRE 22W	28480	
A11W2	8159-0005	8		WIRE 22W	28480	
A11W3	8159-0005	8		WIRE 22W	28480	
A11W4	8159-0005	0		WIRE 22W	28480	
	1258-0141		2	JUMPER-REMOVABLE		
	0340-0060		4	TERMINAL STUD SPCL F01160 PRESS RIG	94291	011-6809 000 209
	04193-26511	0	1	PCBD BLANK	28480	04193-26511

See introduction to this section for ordering information.
 *Indicates factory selected value

Table 6-3. Replaceable Parts

Reference Designation	HP Part Number	C D	Qty	Description	Mfr Code	Mfr Part Number
A12						
A12	04193-66512	3	1	1F 8PF BOARD ASSEMBLY	20480	04193-66512
A12C1	0160-3766	1	4	CAPACITOR-FXD 1000PF +-1% 100VDC MICA	20480	0160-3766
A12C2	0160-2454	2	4	CAPACITOR-FXD 620PF +-1% 300VDC MICA	20480	0160-2454
A12C3	0160-3766	1	1	CAPACITOR-FXD 1000PF +-1% 100VDC MICA	20480	0160-3766
A12C4	0160-2454	2	2	CAPACITOR-FXD 620PF +-1% 300VDC MICA	20480	0160-2454
A12C5	0160-3766	1	1	CAPACITOR-FXD 1000PF +-1% 100VDC MICA	20480	0160-3766
A12C6	0160-2454	2	2	CAPACITOR-FXD 620PF +-1% 300VDC MICA	20480	0160-2454
A12C7	0160-3766	1	1	CAPACITOR-FXD 1000PF +-1% 100VDC MICA	20480	0160-3766
A12C8	0160-2454	2	2	CAPACITOR-FXD 620PF +-1% 300VDC MICA	20480	0160-2454
A12C9	0160-4835	7	14	CAPACITOR-FXD .10UF +-10% 50VDC CER	20480	0160-4835
A12C10	0160-4835	7	7	CAPACITOR-FXD .10UF +-10% 50VDC CER	20480	0160-4835
A12C11	0160-4835	7	7	CAPACITOR-FXD .10UF +-10% 50VDC CER	20480	0160-4835
A12C12	0160-4835	7	7	CAPACITOR-FXD .10UF +-10% 50VDC CER	20480	0160-4835
A12C13	0160-4835	7	7	CAPACITOR-FXD .10UF +-10% 50VDC CER	20480	0160-4835
A12C14	0160-4835	7	7	CAPACITOR-FXD .10UF +-10% 50VDC CER	20480	0160-4835
A12C15	0160-4835	7	7	CAPACITOR-FXD .10UF +-10% 50VDC CER	20480	0160-4835
A12C16	0160-4835	7	7	CAPACITOR-FXD .10UF +-10% 50VDC CER	20480	0160-4835
A12C17	0180-0291	3	2	CAPACITOR-FXD 1UF+-10% 35VDC TA	56289	1500105X9035A2
A12C18	0180-0291	3	3	CAPACITOR-FXD 1UF+-10% 35VDC TA	56259	1500105X9035A2
A12C19	0180-1083	3	4	CAPACITOR-FXD 33UF 25VDC AL	20480	0180-1083
A12C20	0180-1083	3	3	CAPACITOR-FXD 33UF 25VDC AL	20480	0180-1083
A12C21	0160-4831	3	4	CAPACITOR-FXD 4700PF +-10% 100VDC CER	20480	0160-4831
A12C22	0160-4831	3	4	CAPACITOR-FXD 4700PF +-10% 100VDC CER	20480	0160-4831
A12C23	0160-4831	3	3	CAPACITOR-FXD 4700PF +-10% 100VDC CER	20480	0160-4831
A12C24	0180-1083	3	3	CAPACITOR-FXD 33UF 25VDC AL	20480	0180-1083
A12C25	0180-1083	3	3	CAPACITOR-FXD 33UF 25VDC AL	20480	0180-1083
A12C26	0160-4831	3	3	CAPACITOR-FXD 4700PF +-10% 100VDC CER	20480	0160-4831
A12C27	0160-4835	7	7	CAPACITOR-FXD .10UF +-10% 50VDC CER	20480	0160-4835
A12C28	0160-4835	7	7	CAPACITOR-FXD .10UF +-10% 50VDC CER	20480	0160-4835
A12C29	0160-4835	7	7	CAPACITOR-FXD .10UF +-10% 50VDC CER	20480	0160-4835
A12C30	0160-4835	7	7	CAPACITOR-FXD .10UF +-10% 50VDC CER	20480	0160-4835
A12C31	0160-4835	7	7	CAPACITOR-FXD .10UF +-10% 50VDC CER	20480	0160-4835
A12C32	0160-4835	7	7	CAPACITOR-FXD .10UF +-10% 50VDC CER	20480	0160-4835
A12C33	0180-2951	6	2	CAPACITOR-FXD 330PF+-20% 16VDC AL	20480	0180-2951
A12C34	0180-2951	6	6	CAPACITOR-FXD 330PF+-20% 16VDC AL	20480	0180-2951
A12L1	9140-0129	1	4	INDUCTOR RF-CH-M/D 220UH 5% .166DX.385LG	20480	9140-0129
A12L2	9140-0129	1	1	INDUCTOR RF-CH-M/D 220UH 5% .166DX.385LG	20480	9140-0129
A12L3	9100-2259	8	4	INDUCTOR RF-CH-M/D 1.5UH 10% .1050X.26LG	20480	9100-2259
A12L4	9100-2259	8	8	INDUCTOR RF-CH-M/D 1.5UH 10% .1050X.26LG	20480	9100-2259
A12L5	9100-2259	8	8	INDUCTOR RF-CH-M/D 1.5UH 10% .1050X.26LG	20480	9100-2259
A12L6	9140-0129	1	1	INDUCTOR RF-CH-M/D 220UH 5% .166DX.385LG	20480	9140-0129
A12L7	9140-0129	1	1	INDUCTOR RF-CH-M/D 220UH 5% .166DX.385LG	20480	9140-0129
A12L8	9100-2259	8	8	INDUCTOR RF-CH-M/D 1.5UH 10% .1050X.26LG	20480	9100-2259
A12Q1	1853-0314	9	1	TRANSISTOR PNP 2N2905A SI TO-18 PD=600MW	04713	2N2905A
A12Q2	1853-0201	9	1	TRANSISTOR PNP 2N2907A SI TO-18 PD=400MW	04713	2N2907A
A12Q3	1854-0637	1	1	TRANSISTOR NPN 2N2219A SI TO-5 PD=800MW	01295	2N2219A
A12Q4	1854-0477	7	1	TRANSISTOR NPN 2N2222A SI TO-18 PD=500MW	04713	2N2222A
A12R1	0698-8833	8	2	RESISTOR 17.0K 1% .125W F TC=0+-100	24546	C4 1/8-T0-1702-F
A12R2	0698-8833	9	2	RESISTOR 200K 1% .1W F TC=0+-15	07216	PAR 1/10-T10-2003-B
A12R3	2100-3207	1	2	RESISTOR-TRMR 5% 10% C SIDE-ADJ 1-TRN	20480	2100 3207
A12R4	2100-3123	0	2	RESISTOR-TRMR 5% 10% C SIDE-ADJ 17 TRN	02111	43P501
A12R5	0698-8833	2	8	RESISTOR-FXD 10K 0.0% 0.1%	20480	0698-8833
A12R6	0698-3460	1	2	RESISTOR 422K 1% .125W F TC=0+-100	20480	0698-3460
A12R7	0698-8833	2	2	RESISTOR-FXD 10K 0.0% 0.1%	20480	0698-8833
A12R8	0693-2215	1	2	RESISTOR 220 5% .25W FC TC=400/+600	01121	062215
A12R9	0698-3136	8	8	RESISTOR 17.0K 1% .125W F TC=0+-100	24546	C4 1/8-T0-1702-F
A12R10	0698-8833	9	9	RESISTOR 200K 1% .1W F TC=0+-15	07216	PAR-1/10-T10-2003-B
A12R11	2100-3207	1	1	RESISTOR-TRMR 5% 10% C SIDE-ADJ 1-TRN	20480	2100 3207
A12R12	2100-3123	0	0	RESISTOR-TRMR 5% 10% C SIDE-ADJ 17 TRN	02111	43P501
A12R13	0698-8833	2	2	RESISTOR-FXD 10K 0.0% 0.1%	20480	0698-8833
A12R14	0698-3460	1	1	RESISTOR 422K 1% .125W F TC=0+-100	20480	0698-3460
A12R15	0698-8833	2	2	RESISTOR-FXD 10K 0.0% 0.1%	20480	0698-8833
A12R16	0693-2215	1	1	RESISTOR 220 5% .25W FC TC=400/+600	01121	062215
A12R17	0698-8833	2	2	RESISTOR-FXD 10K 0.0% 0.1%	20480	0698-8833
A12R18	0698-8833	2	2	RESISTOR-FXD 10K 0.0% 0.1%	20480	0698-8833
A12R19	0698-8833	2	2	RESISTOR-FXD 10K 0.0% 0.1%	20480	0698-8833
A12R20	0698-8833	2	2	RESISTOR-FXD 10K 0.0% 0.1%	20480	0698-8833
A12R21	0757-0280	3	4	RESISTOR 1K 1% .125W F TC=0+-100	24546	C4 1/8-T0-1001-F
A12R22	0757-0430	3	4	RESISTOR 5.11K 1% .125W F TC=0+-100	24546	C4 1/8-T0-5111-F
A12R23	0757-0430	3	3	RESISTOR 5.11K 1% .125W F TC=0+-100	24546	C4 1/8-T0 5111 F
A12R24	0757-0280	3	3	RESISTOR 1K 1% .125W F TC=0+-100	24546	C4 1/8-T0 1001 F
A12R25	0757-0280	3	3	RESISTOR 1K 1% .125W F TC=0+-100	24546	C4 1/8-T0 1001 F

See introduction to this section for ordering information
 *Indicates factory selected value

Table 6-3. Replaceable Parts

Reference Designation	HP Part Number	C D	Qty	Description	Mfr Code	Mfr Part Number
A12R26	0757-0438	3		RESISTOR 5.11K 1% .125W F TC=0+-100	24546	C4-1/8-T0-5111-F
A12R27	0757-0438	3		RESISTOR 5.11K 1% .125W F TC=0+-100	24546	C4-1/8-T0-5111-F
A12R28	0757-0280	3		RESISTOR 1K 1% .125W F TC=0+-100	24546	C4-1/8-T0-1001-F
A12R29	0683-1035	1	2	RESISTOR 10K 5% .25W FC TC=-400/+700	01121	CB1035
A12R30	0683-1035	1		RESISTOR 10K 5% .25W FC TC=-400/+700	01121	CB1035
A12R31	0698-3620	5	2	RESISTOR 100 5% 2W MO TC=0+-200	28480	0698-3620
A12R32	0698-3226	7	2	RESISTOR 6.49K 1% .125W F TC=0+-100	24546	C4-1/8-T0-6491-F
A12R33	3698-3498	5	2	RESISTOR 8.66K 1% .125W F TC=0+-100	24546	C4-1/8-T0-866R-F
A12R34	0698-3498	5		RESISTOR 8.66K 1% .125W F TC=0+-100	24546	C4-1/8-T0-866R-F
A12R35	0698-3226	7		RESISTOR 6.49K 1% .125W F TC=0+-100	24546	C4-1/8-T0-6491-F
A12R36	0698-3620	5		RESISTOR 100 5% 2W MO TC=0+-200	28480	0698-3620
A12U1	1826-0081	0	6	IC OP AMP WB T0-99 PKG	27014	LM318H
A12U2	1826-0081	0		IC OP AMP WB T0-99 PKG	27014	LM318H
A12U3	1826-0081	0		IC OP AMP WB T0-99 PKG	27014	LM318H
A12U4	1826-0081	0		IC OP AMP WB T0-99 PKG	27014	LM318H
A12U5	1826-0081	0		IC OP AMP WB T0-99 PKG	27014	LM318H
A12U6	1826-0081	0		IC OP AMP WB T0-99 PKG	27014	LM318H
A12U7	1826-0521	3	2	IC OP AMP DUAL 8-DIP-P PKG	01295	TL072CP
A12U8	1820-1958	0	2	IC SWITCH ANLG QUAD 14-DIP-P PKG	0192B	CD4016BE
A12U9	1820-1958	0		IC SWITCH ANLG QUAD 14-DIP-P PKG	0192B	CD4016BE
A12U10	1826-0521	3		IC OP AMP DUAL 8-DIP-P PKG	01295	TL072CP
	1205-0050	7	2	HEAT SINK T0-5/T0-39-CS	28480	1205-0050
	04193-26512	0	1	PCBD BLANK	28480	04193-26512

See introduction to this section for ordering information
 *Indicates factory selected value

Table 6-3. Replaceable Parts

Reference Designation	HP Part Number	C D	Qty	Description	Mfr Code	Mfr Part Number
A13						
A13	04193-66513	4	1	DETECTOR BOARD ASSEMBLY	28480	04193-66513
A13C1	0160-0116	1	1	CAPACITOR-FXD .001UF +-10% 35VDC TA	56289	150D685X9035BP
A13C2	0160-4835	7	20	CAPACITOR-FXD .1UF +-10% 50VDC CER	28480	0160-4835
A13C3	0160-2208	4	2	CAPACITOR-FXD 330PF +-5% 300VDC MICA	28480	0160-2208
A13C4	0160-2208	4		CAPACITOR-FXD 330PF +-5% 300VDC MICA	28480	0160-2208
A13C5	0160-4835	7		CAPACITOR-FXD .1UF +-10% 50VDC CER	28480	0160-4835
A13C6	0160-4835	7		CAPACITOR-FXD .1UF +-10% 50VDC CER	28480	0160-4835
A13C7	0160-4835	7		CAPACITOR-FXD .1UF +-10% 50VDC CER	28480	0160-4835
A13C8	0160-4835	7		CAPACITOR-FXD .1UF +-10% 50VDC CER	28480	0160-4835
A13C9	0180-2951	6	7	CAPACITOR-FXD 33UF +-20% 16VDC AL	28480	0180-2951
A13C10	0180-2951	6	6	CAPACITOR-FXD 33UF +-20% 16VDC AL	28480	0180-2951
A13C11	0160-4833	5	1	CAPACITOR-FXD .022UF +-10% 100VDC CER	28480	0160-4833
A13C12	0160-4535	4	5	CAPACITOR-FXD .1UF +-10% 50VDC CER	28480	0160-4535
A13C13	0160-2201	7	1	CAPACITOR-FXD 51PF +-5% 300VDC MICA	28480	0160-2201
A13C14	0180-1083	3	2	CAPACITOR-FXD 33UF 25VDC AL	28480	0180-1083
A13C15	0180-1083	3		CAPACITOR-FXD 33UF 25VDC AL	28480	0180-1083
A13C16	0160-4535	4		CAPACITOR-FXD .1UF +-10% 50VDC CER	28480	0160-4535
A13C17	0160-4835	7		CAPACITOR-FXD .1UF +-10% 50VDC CER	28480	0160-4835
A13C18	0160-4835	7		CAPACITOR-FXD .1UF +-10% 50VDC CER	28480	0160-4835
A13C19	0160-4535	4		CAPACITOR-FXD .1UF +-10% 50VDC CER	28480	0160-4535
A13C20	0160-4835	7		CAPACITOR-FXD .1UF +-10% 50VDC CER	28480	0160-4835
A13C21	0160-4835	7		CAPACITOR-FXD .1UF +-10% 50VDC CER	28480	0160-4835
A13C22	0160-4835	7		CAPACITOR-FXD .1UF +-10% 50VDC CER	28480	0160-4835
A13C23	0160-4835	7		CAPACITOR-FXD .1UF +-10% 50VDC CER	28480	0160-4835
A13C24	0180-2951	6		CAPACITOR-FXD 33UF +-20% 16VDC AL	28480	0180-2951
A13C25	0160-4835	7		CAPACITOR-FXD .1UF +-10% 50VDC CER	28480	0160-4835
A13C26	0160-4835	7		CAPACITOR-FXD .1UF +-10% 50VDC CER	28480	0160-4835
A13C27	0160-4835	7		CAPACITOR-FXD .1UF +-10% 50VDC CER	28480	0160-4835
A13C28	0160-4835	7		CAPACITOR-FXD .1UF +-10% 50VDC CER	28480	0160-4835
A13C29	0160-4834	6	4	CAPACITOR-FXD .047UF +-10% 100VDC CER	28480	0160-4834
A13C30	0160-4834	6		CAPACITOR-FXD .047UF +-10% 100VDC CER	28480	0160-4834
A13C31	0180-2951	6		CAPACITOR-FXD 33UF +-20% 16VDC AL	28480	0180-2951
A13C32	0180-2951	6		CAPACITOR-FXD 33UF +-20% 16VDC AL	28480	0180-2951
A13C33	0180-2951	6		CAPACITOR-FXD 33UF +-20% 16VDC AL	28480	0180-2951
A13C34	0180-2951	6		CAPACITOR-FXD 33UF +-20% 16VDC AL	28480	0180-2951
A13C35	0140-0129	1	1	CAPACITOR-FXD 560PF +-2% 300VDC MICA	72135	DN15F56100300WJ1CR
A13C36	0160-4535	4		CAPACITOR-FXD .1UF +-10% 50VDC CER	28480	0160-4535
A13C37	0160-4535	4		CAPACITOR-FXD .1UF +-10% 50VDC CER	28480	0160-4535
A13C38	0160-4835	7		CAPACITOR-FXD .1UF +-10% 50VDC CER	28480	0160-4835
A13C39	0160-4834	6		CAPACITOR-FXD .047UF +-10% 100VDC CER	28480	0160-4834
A13C40	0160-4834	6		CAPACITOR-FXD .047UF +-10% 100VDC CER	28480	0160-4834
A13C41	0160-4835	7		CAPACITOR-FXD .1UF +-10% 50VDC CER	28480	0160-4835
A13C42	0160-4835	7		CAPACITOR-FXD .1UF +-10% 50VDC CER	28480	0160-4835
A13C43	0160-4835	7		CAPACITOR-FXD .1UF +-10% 50VDC CER	28480	0160-4835
A13C44	0160-4835	7		CAPACITOR-FXD .1UF +-10% 50VDC CER	28480	0160-4835
A13CR1	1901-0040	1	9	DIODE-SWITCHING 30V 50MA 2NS DO-35	28480	1901-0040
A13CR2	1901-0040	1		DIODE-SWITCHING 30V 50MA 2NS DO-35	28480	1901-0040
A13CR3	1902-0064	1	3	DIODE-ZNR 7.5V 5% DO-35 PD=.4W TC=+.05%	28480	1902-0064
A13CR4	1901-0040	1		DIODE-SWITCHING 30V 50MA 2NS DO-35	28480	1901-0040
A13CR5	1902-0049	2	1	DIODE-ZNR 6.19V 5% DO-35 PD=.4W	28480	1902-0049
A13CR6	1901-0040	1		DIODE-SWITCHING 30V 50MA 2NS DO-35	28480	1901-0040
A13CR7	1901-0040	1		DIODE-SWITCHING 30V 50MA 2NS DO-35	28480	1901-0040
A13CR8	1902-0064	1		DIODE-ZNR 7.5V 5% DO-35 PD=.4W TC=+.05%	28480	1902-0064
A13CR9	1902-0064	1		DIODE-ZNR 7.5V 5% DO-35 PD=.4W TC=+.05%	28480	1902-0064
A13CR10	1901-0040	1		DIODE-SWITCHING 30V 50MA 2NS DO-35	28480	1901-0040
A13CR11	1901-0040	1		DIODE-SWITCHING 30V 50MA 2NS DO-35	28480	1901-0040
A13CR12	1901-0040	1		DIODE-SWITCHING 30V 50MA 2NS DO-35	28480	1901-0040
A13CR13	1901-0040	1		DIODE-SWITCHING 30V 50MA 2NS DO-35	28480	1901-0040
A13J1	1251-4822	6	1	CONNECTOR 3-PIN H POST TYPE	28480	1251-4822
A13L1	9140-0114	4	2	INDUCTOR RF-CH-M/D 10UH 10% .166DX .385LG	28480	9140-0114
A13L2	9140-0114	4		INDUCTOR RF-CH-M/D 10UH 10% .166DX .385LG	28480	9140-0114
A13L3	9140-0129	1	6	INDUCTOR RF-CH-M/D 220UH 5% .166DX .385LG	28480	9140-0129
A13L4	9140-0129	1		INDUCTOR RF-CH-M/D 220UH 5% .166DX .385LG	28480	9140-0129
A13L5	9140-0129	1		INDUCTOR RF-CH-M/D 220UH 5% .166DX .385LG	28480	9140-0129
A13L6	9140-0129	1		INDUCTOR RF-CH-M/D 220UH 5% .166DX .385LG	28480	9140-0129
A13L7	9140-0129	1		INDUCTOR RF-CH-M/D 220UH 5% .166DX .385LG	28480	9140-0129
A13L8	9140-0129	1		INDUCTOR RF-CH-M/D 220UH 5% .166DX .385LG	28480	9140-0129
A13R1	2100-3352	7	1	RESISTOR-TMR 1K 10% C SIDE-ADJ 1-TRN	28480	2100-3352
A13R2	0757-0442	2	8	RESISTOR 19K 1% .125W F TC=0+-100	24546	C4-1/8-T0-1002-F
A13R3	0757-0279	0	2	RESISTOR 3.16K 1% .125W F TC=0+-100	24546	C4-1/8-T0-3162-F
A13R4	0698-3160	8	2	RESISTOR 31.6K 1% .125W F TC=0+-100	24546	C4-1/8-T0-3162-F
A13R5	0698-3160	8		RESISTOR 31.6K 1% .125W F TC=0+-100	24546	C4-1/8-T0-3162-F

See introduction to this section for ordering information
 *Indicates factory selected value

Table 6-3. Replaceable Parts

Reference Designation	HP Part Number	C D	Qty	Description	Mfr Code	Mfr Part Number
A13R6	6698-3279	6	1	RESISTOR 4.99K 1% .125W F TC=0+-100	24546	C4-1/8-T0-4971-F
A13R7	0757-0424	7	2	RESISTOR 1.1K 1% .125W F TC=0+-100	24546	C4-1/8-T0-1101-F
A13R8	0757-0424	7		RESISTOR 1.1K 1% .125W F TC=0+-100	24546	C4-1/8-T0-1101-F
A13R9	0698-3155	1	5	RESISTOR 4.64K 1% .125W F TC=0+-100	24546	C4-1/8-T0-4641-F
A13R10	0757-0442	9		RESISTOR 10K 1% .125W F TC=0+-100	24546	C4-1/8-T0-1001-F
A13R11	0698-0063	8	1	RESISTOR 1.96K 1% .125W F TC=0+-100	24546	C4-1/8-T0-1961-F
A13R12	0757-0445	6	1	RESISTOR 100K 1% .125W F TC=0+-100	24546	C4-1/8-T0-1003-F
A13R13	0683-1035	6	1	RESISTOR 10K 5% .25W FC TC=-400/+600	01121	CB1035
A13R14	0698-3155	1		RESISTOR 4.64K 1% .125W F TC=0+-100	24546	C4-1/8-T0-4641-F
A13R15	0698-3359	7	1	RESISTOR 12.7K 1% .125W F TC=0+-100	24546	C4-1/8-T0-1272-F
A13R16	0698-3155	1		RESISTOR 4.64K 1% .125W F TC=0+-100	24546	C4-1/8-T0-4641-F
A13R17	0698-3162	0	3	RESISTOR 46.4K 1% .125W F TC=0+-100	24546	C4-1/8-T0-4642-F
A13R18	0683-1035	1	4	RESISTOR 10K 5% .25W FC TC=-400/+600	01121	CB1035
A13R19	1010-0205	7	3	NETWORK-RES 0-51P4.7K OHM X 7	01121	208A472
A13R20	0698-3162	0		RESISTOR 46.4K 1% .125W F TC=0+-100	24546	C4-1/8-T0-4642-F
A13R21	0757-0279	0		RESISTOR 3.16K 1% .125W F TC=0+-100	24546	C4-1/8-T0-3161-F
A13R22	0698-3162	0		RESISTOR 46.4K 1% .125W F TC=0+-100	24546	C4-1/8-T0-4642-F
A13R23	1010-0205	7		NETWORK-RES 0-51P4.7K OHM X 7	01121	208A472
A13R24	0683-6815	5	4	RESISTOR 680 5% .25W FC TC=-400/+600	01121	CB6815
A13R25	0683-6815	5		RESISTOR 680 5% .25W FC TC=-400/+600	01121	CB6815
A13R26	0683-6815	5		RESISTOR 680 5% .25W FC TC=-400/+600	01121	CB6815
A13R27	0683-6815	5		RESISTOR 680 5% .25W FC TC=-400/+600	01121	CB6815
A13R28	0683-1035	1		RESISTOR 10K 5% .25W FC TC=-400/+600	01121	CB1035
A13R29	0683-1025	9	9	RESISTOR 1K 5% .25W FC TC=-400/+600	01121	CB1025
A13R30	0683-1025	9		RESISTOR 1K 5% .25W FC TC=-400/+600	01121	CB1025
A13R31	0683-1045	3	2	RESISTOR 100K 5% .25W FC TC=-400/+800	01121	CB1045
A13R32	0683-1025	9		RESISTOR 1K 5% .25W FC TC=-400/+600	01121	CB1025
A13R33	0683-1025	9		RESISTOR 1K 5% .25W FC TC=-400/+600	01121	CB1025
A13R34	0757-0442	9		RESISTOR 10K 1% .125W F TC=0+-100	24546	C4-1/8-T0-1002-F
A13R35	0698-4431	8	2	RESISTOR 2.05K 1% .125W F TC=0+-100	24546	C4-1/8-T0-2051-F
A13R36	0698-4431	8		RESISTOR 2.05K 1% .125W F TC=0+-100	24546	C4-1/8-T0-2051-F
A13R37	0683-1045	3		RESISTOR 100K 5% .25W FC TC=-400/+800	01121	CB1045
A13R38	0683-1025	9		RESISTOR 1K 5% .25W FC TC=-400/+600	01121	CB1025
A13R39	0683-1025	9		RESISTOR 1K 5% .25W FC TC=-400/+600	01121	CB1025
A13R40	0683-1025	9		RESISTOR 1K 5% .25W FC TC=-400/+600	01121	CB1025
A13R41	0757-0280	3	2	RESISTOR 1K 1% .125W F TC=0+-100	24546	C4-1/8-T0-1001-F
A13R42	0698-3155	1		RESISTOR 4.64K 1% .125W F TC=0+-100	24546	C4-1/8-T0-4641-F
A13R43	0683-1035	1		RESISTOR 10K 5% .25W FC TC=-400/+600	01121	CB1035
A13R44	1010-0205	7		NETWORK-RES 0-51P4.7K OHM X 7	01121	208A472
A13R45	0683-1025	7	1	RESISTOR 1.0K 5% .25W FC TC=-400/+600	01121	CB1025
A13R46	0757-0280	3		RESISTOR 1K 1% .125W F TC=0+-100	24546	C4-1/8-T0-1001-F
A13R47	0698-3155	1		RESISTOR 4.64K 1% .125W F TC=0+-100	24546	C4-1/8-T0-4641-F
A13R48	0757-0442	9		RESISTOR 10K 1% .125W F TC=0+-100	24546	C4-1/8-T0-1002-F
A13R49	0757-0442	9		RESISTOR 10K 1% .125W F TC=0+-100	24546	C4-1/8-T0-1002-F
A13R50	0757-0442	9		RESISTOR 10K 1% .125W F TC=0+-100	24546	C4-1/8-T0-1002-F
A13R51	0757-0298	5	1	RESISTOR 6.15K 1% .125W F TC=0+-100	19731	MF401/8-T0-6191-F
A13R52	0683-1025	9		RESISTOR 1K 5% .25W FC TC=-400/+600	01121	CB1025
A13R53	0683-1025	9		RESISTOR 1K 5% .25W FC TC=-400/+600	01121	CB1025
A13R54	0683-1035	1		RESISTOR 10K 5% .25W FC TC=-400/+600	01121	CB1035
A13R55	0757-0442	9		RESISTOR 10K 1% .125W F TC=0+-100	24546	C4-1/8-T0-1002-F
A13R56	0757-0442	9		RESISTOR 10K 1% .125W F TC=0+-100	24546	C4-1/8-T0-1002-F
A13U1	1026-0521	3	2	IC OP AMP DUAL 8-DIP-P PKG	01295	TL072CP
A13U2	1026-0693	0	3	IC OP AMP LOW-BIAS HI-IMPD TO-99 PKG	27614	LF351H
A13U3	1026-0139	8	2	IC COMPARATOR GP QUAD 14-DIP-P PKG	01295	LM339N
A13U4	1026-1355	2	1	IC NJ CMOS NONINVERTING RETRIC/RESET DUAL	04713	MC14528BCP
A13U5	1026-0139	8		IC COMPARATOR GP QUAD 14-DIP-P PKG	01295	LM339N
A13U6	1026-0229	8	1	IC OP AMP LOW-DRIFT TO-99 PKG	06665	OP-05CJ
A13U7	1026-0693	0		IC OP AMP LOW-BIAS HI-IMPD TO-99 PKG	27614	LF351H
A13U8	1026-0521	3		IC OP AMP DUAL 8-DIP-P PKG	01295	TL072CP
A13U9	1026-0175	3	1	IC COMPARATOR GP DUAL 14-DIP-P PKG	27614	LM319N
A13U10	1026-1747	5	1	IC GATE CMOS NAND QUAD 2-IMP	04713	MC14011LCP
A13U11	1026-1601	0	1	IC GATE CMOS EXOR-OR QUAD 2-IMP	01298	CM4870BC
A13U12	1026-0693	0		IC OP AMP LOW-BIAS HI-IMPD TO-99 PKG	27614	LF351H
A13U13	1026-0081	6	1	IC OP AMP WB TO-99 PKG	27614	LM318H
A13U14	1026-0592	0	3	IC SWITCH ANLG QUAD 14-DIP-P PKG	04713	MC14066LCP
A13U15	1026-0592	0	6	IC SWITCH ANLG QUAD 14-DIP-P PKG	04713	MC14066LCP
A13U16	1026-0592	0		IC SWITCH ANLG QUAD 14-DIP-P PKG	04713	MC14066LCP
	1258-0141		1	JUMPER-REMOVABLE		
	1205-0050	7	1	HEAT SINK T0-5/T0-39-CS	28480	1205-0050
	04193-26513	0	1	PCBD BLANK	28480	04193-26513

See introduction to this section for ordering information.
*Indicates factory selected value

Table 6-3. Replaceable Parts

Reference Designation	HP Part Number	C D	Qty	Description	Mfr Code	Mfr Part Number
A14						
A14	04193-66514	5	1	ADC BOARD ASSEMBLY	28480	04193-66514
A14C1	0160-0127	2	2	CAPACITOR-FXD 1UF +-20% 25VDC CER	28480	0160-0127
A14C2	0160-0127	2	2	CAPACITOR-FXD 1UF +-20% 25VDC CER	28480	0160-0127
A14C3	0180-1083	3	1	CAPACITOR-FXD .33UF 25VDC AL	28480	0180-1083
A14C4	0160-0889	3	2	CAPACITOR-FXD .33UF +-10% 80VDC POLYE	28480	0160-0889
A14C5	0160-0303	6	2	CAPACITOR-FXD .15UF +-10% 200VDC POLYE	28480	0160-0303
A14C6	0160-0303	6	2	CAPACITOR-FXD .15UF +-10% 200VDC POLYE	28480	0160-0303
A14C7	0160-0889	3	2	CAPACITOR-FXD .33UF +-10% 80VDC POLYE	28480	0160-0889
A14C8	0160-4822	2	2	CAPACITOR-FXD 1000PF +-5% 100VDC CER	28480	0160-4822
A14C9	0160-4822	2	2	CAPACITOR-FXD 1000PF +-5% 100VDC CER	28480	0160-4822
A14C10	0160-3901	6	2	CAPACITOR-FXD 2.2UF +-20% 25VDC CER	28480	0160-3901
A14C11	0160-3901	6	2	CAPACITOR-FXD 2.2UF +-20% 25VDC CER	28480	0160-3901
A14C12	0160-4835	7	1	CAPACITOR-FXD .1UF +-10% 50VDC CER	28480	0160-4835
A14J1	1200-0654	7	2	SOCKET-IC 40-CONT DIP DIP-SLDR	28480	1200-0654
A14J2	1200-0654	7	2	SOCKET-IC 40-CONT DIP DIP-SLDR	28480	1200-0654
A14Q1	1854-0477	7	1	TRANSISTOR NPN 2N2222A SI TO-18 PD=500MW	04713	2N2222A
A14R1	0683-1045	3	2	RESISTOR 100K 5% .25W FC TC=-400/+800	01121	CR1045
A14R2	0683-1045	3	2	RESISTOR 100K 5% .25W FC TC=-400/+800	01121	CR1045
A14R3	0683-2225	3	1	RESISTOR 2.2K 5% .25W FC TC=-400/+700	01121	CR2225
A14R4	0757-0274	5	1	RESISTOR 1.21K 1% .125W F TC=0+-100	24546	C4-1/8-T0-1211-F
A14R5	0757-0280	3	1	RESISTOR 1K 1% .125W F TC=0+-100	24546	C4-1/8-T0-1001-F
A14R6	0683-4715	0	2	RESISTOR 470 5% .25W FC TC=-400/+600	01121	CR4715
A14R7	0683-4715	0	2	RESISTOR 470 5% .25W FC TC=-400/+600	01121	CR4715
A14R8	0683-4725	2	1	RESISTOR 4.7K 5% .25W FC TC=-400/+700	01121	CR4725
A14R9	0683-3315	4	1	RESISTOR 330 5% .25W FC TC=-400/+600	01121	CR3315
A14U1	1820-1197	9	1	IC GATE TTL LS NAND QUAD 2-INP	01295	SN74LS00N
A14U2	1820-1112	8	3	IC FF TTL LS D-TYPE POS-EDGE-TRIG	01295	SN74LS74AN
A14U3	1826-0746	2	2	IC A/D CONVERTER CMOS 40-DIP-P PKG	28480	1826-0746
A14U4	1826-0746	2	2	IC A/D CONVERTER CMOS 40-DIP-P PKG	28480	1826-0746
A14U5	1820-1199	1	1	IC INV TTL LS HEX 1-INP	01295	SN74LS04N
A14U6	1820-2024	3	1	IC DRV R TTL LS LINE DRV OCTL	01295	SN74LS244N
A14U7	1820-1216	3	1	IC DCDR TTL LS 3-TO-8-LINE 3-INP	01295	SN74LS139N
A14U8	1820-1204	9	1	IC GATE TTL LS NAND DUAL 4-INP	01295	SN74LS20N
A14U9	1820-1112	8	3	IC FF TTL LS D-TYPE POS-EDGE-TRIG	01295	SN74LS74AN
A14U10	1820-1112	8	3	IC FF TTL LS D-TYPE POS-EDGE-TRIG	01295	SN74LS74AN
A14U11	1820-1432	5	2	IC CNTR TTL LS BIN SYNCHRD POS-EDGE-TRIG	01295	SN74LS163AN
A14U12	1820-1432	5	2	IC CNTR TTL LS BIN SYNCHRD POS-EDGE-TRIG	01295	SN74LS163AN
	04193-26514	0	1	PCBD BLANK	28480	04193-26514

See introduction to this section for ordering information
 *Indicates factory selected value

Table 6-3. Replaceable Parts

Reference Designation	HP Part Number	C D	Qty	Description	Mfr Code	Mfr Part Number
A15						
A15	34193-66515	6	1	ANALOG OUTPUT BOARD ASSEMBLY	28480	34193-66515
A15C1	0140-0208	8	6	CAPACITOR-FXD 680PF +-5% 300VDC MICA	28480	0140-0208
A15C2	0140-0208	8		CAPACITOR-FXD 680PF +-5% 300VDC MICA	28480	0140-0208
A15C3	0140-0208	8		CAPACITOR-FXD 680PF +-5% 300VDC MICA	72136	DM15F681J0300WV1CR
A15C4	0140-0208	8		CAPACITOR-FXD 680PF +-5% 300VDC MICA	72136	DM15F681J0300WV1CR
A15C5	0140-0208	8		CAPACITOR-FXD 680PF +-5% 300VDC MICA	28480	0140-0208
A15C6	0140-0208	8		CAPACITOR-FXD 680PF +-5% 300VDC MICA	28480	0140-0208
A15C7	0160-0127	2	6	CAPACITOR-FXD 10UF +-20% 25VDC CER	28480	0160-0127
A15C8	0160-0127	2		CAPACITOR-FXD 10UF +-20% 25VDC CER	28480	0160-0127
A15C9	0160-0127	2		CAPACITOR-FXD 10UF +-20% 25VDC CER	28480	0160-0127
A15C10	0160-4835	7	3	CAPACITOR-FXD .10UF +-10% 50VDC CER	28480	0160-4835
A15C11	0160-4835	7		CAPACITOR-FXD .10UF +-10% 50VDC CER	28480	0160-4835
A15C12	0160-4835	7		CAPACITOR-FXD .10UF +-10% 50VDC CER	28480	0160-4835
A15C13	0180-1083	3	5	CAPACITOR-FXD 330UF 25VDC AL	28480	0180-1083
A15C14	0160-0127	2		CAPACITOR-FXD 10UF +-20% 25VDC CER	28480	0160-0127
A15C15	0180-1083	3		CAPACITOR-FXD 330UF 25VDC AL	28480	0180-1083
A15C16	0180-1083	3		CAPACITOR-FXD 330UF 25VDC AL	28480	0180-1083
A15C17	0160-0127	2		CAPACITOR-FXD 10UF +-20% 25VDC CER	28480	0160-0127
A15C18	0180-1083	3		CAPACITOR-FXD 330UF 25VDC AL	28480	0180-1083
A15C19	0160-0127	2		CAPACITOR-FXD 10UF +-20% 25VDC CER	28480	0160-0127
A15C20	0180-1083	3		CAPACITOR-FXD 330UF 25VDC AL	28480	0180-1083
A15L1	9140-0210	1	2	INDUCTOR RF-CH-MLD 100UH 5% .166DX.385LG	28480	9140-0210
A15L2	9140-0210	1		INDUCTOR RF-CH-MLD 100UH 5% .166DX.385LG	28480	9140-0210
A15R1	2100-3273	1	3	RESISTOR-TRMR 2K 10% C SIDE-ADJ 1-TRN	28480	2100-3273
A15R2	2100-3273	1		RESISTOR-TRMR 2K 10% C SIDE-ADJ 1-TRN	28480	2100-3273
A15R3	2100-3273	1		RESISTOR-TRMR 2K 10% C SIDE-ADJ 1-TRN	28480	2100-3273
A15R4	0683-4725	2	3	RESISTOR 4.7K 5% .25W FC TC=-400/+700	01121	CB4725
A15R5	0683-1025	9	6	RESISTOR 1K 5% .25W FC TC=-400/+600	01121	CB1025
A15R6	0683-2235	5	3	RESISTOR 22K 5% .25W FC TC=-400/+800	01121	CB2235
A15R7	0683-1025	9		RESISTOR 1K 5% .25W FC TC=-400/+600	01121	CB1025
A15R8	0683-2235	5		RESISTOR 22K 5% .25W FC TC=-400/+800	01121	CB2235
A15R9	0683-1025	9		RESISTOR 1K 5% .25W FC TC=-400/+600	01121	CB1025
A15R10	0683-2235	5		RESISTOR 22K 5% .25W FC TC=-400/+800	01121	CB2235
A15R11	0683-4725	2		RESISTOR 4.7K 5% .25W FC TC=-400/+700	01121	CB4725
A15R12	0683-2735	0	2	RESISTOR 27K 5% .25W FC TC=-400/+800	01121	CB2735
A15R13	0683-2735	0		RESISTOR 27K 5% .25W FC TC=-400/+800	01121	CB2735
A15R14	0683-4725	2		RESISTOR 4.7K 5% .25W FC TC=-400/+700	01121	CB4725
A15R15	1810-0279	5	2	NETWORK-RES 10-SIP4.7K OHM X 9	01121	210A472
A15R16	1810-0279	5		NETWORK-RES 10-SIP4.7K OHM X 9	01121	210A472
A15R17	0683-1025	9		RESISTOR 1K 5% .25W FC TC=-400/+600	01121	CB1025
A15R18	0683-1025	9		RESISTOR 1K 5% .25W FC TC=-400/+600	01121	CB1025
A15R19	0683-1025	9		RESISTOR 1K 5% .25W FC TC=-400/+600	01121	CB1025
A15U1	1820-1278	7	2	IC CNTR TTL LS BIN UP/DOWN SYNCHRO	01295	SN74LS191N
A15U2	1820-1278	7		IC CNTR TTL LS BIN UP/DOWN SYNCHRO	01295	SN74LS191N
A15U3	1820-1199	1	2	IC INV TTL LS HEX 1-INP	01295	SN74LS04N
A15U4	1820-1204	9	2	IC GATE TTL LS NAND DUAL 4-INP	01295	SN74LS26N
A15U5	1820-1112	8	1	IC FF TTL LS D-TYPE POS-EDGE-TRIG	01295	SN74LS74AN
A15U6	1820-1204	9		IC GATE TTL LS NAND DUAL 4-INP	01295	SN74LS26N
A15U7	1820-1423	4	1	IC RV TTL LS MONOSTBL RETRTG DUAL	01295	SN74LS123N
A15U8	1820-1197	9	1	IC GATE TTL LS NAND QUAD 2-INP	01295	SN74LS00N
A15U9	1820-1216	3	1	IC BCDR TTL LS 3-TO-8 LINE 3-INP	01295	SN74LS138N
A15U10	1820-1144	6	1	IC GATE TTL LS NOR QUAD 2-INP	01295	SN74LS02N
A15U11	1813-0105	2	1	IC D/A CONVERTER 24-DIP-CER PKG	8E175	DAC00-CBT-V
A15U12	1820-1374	4	1	IC SWITCH ANLG QUAD 16-DIP-P PKG	24355	AD7510DIJN
A15U13	1820-1199	1		IC INV TTL LS HEX 1-INP	01295	SN74LS04N
A15U14	1820-2024	3	1	IC DRVR TTL LS LINE DRVR OCTL	01295	SN74LS244N
A15U15	1820-1436	9	3	IC TTL LS 16-BIT RAM STAT 45-NS 0-C	01295	SN74LS170N
A15U16	1820-1436	9		IC TTL LS 16-BIT RAM STAT 45-NS 0-C	01295	SN74LS170N
A15U17	1820-1436	9		IC TTL LS 16-BIT RAM STAT 45-NS 0-C	01295	SN74LS170N
A15U18	1826-0410	9	2	IC OP AMP LOW-BIAS-H-IMPD QUAD 14-DIP-P	01295	TL084CN
A15U19	1826-0410	9		IC OP AMP LOW-BIAS-H-IMPD QUAD 14-DIP-P	01295	TL084CN
A15J1	1200-0541	1	1	SOCKET-IC 24-CONT DIP DIP-SDDR	28480	1200-0541
	04193-26515	0	1	PCBD BLANK	28480	04193-26515

See introduction to this section for ordering information
 *Indicates factory selected value

Table 6-3. Replaceable Parts

Reference Designation	HP Part Number	C D	Qty	Description	Mfr Code	Mfr Part Number
A16						
A16	94193-66516	7	1	HP-IB BOARD ASSEMBLY	28480	94193-66516
A16C1	0160-0127	2	1	CAPACITOR-FXD 1UF +/-20% 25VDC CER	28480	0160-0127
A16C2	0180-1883	3	1	CAPACITOR-FXD 32UF 25VDC AL	28480	0180-1883
A16J1	1200-0654	7	1	SOCKET-IC 40-CONT DIP DIP-SLDR	28480	1200-0654
A16R1	1810-0279	5	1	NETWORK-RES 10-SIP4.7K OHM X 9	01121	219A472
A16R2	0693-4725	2	1	RESISTOR 4.7K 5% .25W FC TC=-460/+700	01121	CR4725
A16U1	1820-2024	3	1	IC DRV R TTL LS LINE DRV OCTL	01295	SN74LS244N
A16U2	1820-2549	7	1	IC-8291A P HP IB	28480	1820-2549
A16U3	1820-2058	3	4	IC MISC TTL S QUAD	28480	1820-2058
A16U4	1820-2058	3		IC MISC TTL S QUAD	28480	1820-2058
A16U5	1820-1197	1	1	IC INV TTL LS HEX 1-INP	01295	SN74LS04N
A16U6	1820-2058	3		IC MISC TTL S QUAD	28480	1820-2058
A16U7	1820-2058	3		IC MISC TTL S QUAD	28480	1820-2058
A16U8	1820-1197	9	1	IC GATE TTL LS NAND QUAD 2-INP	01295	SN74LS00N
	04193-26516	0	1	PCBD BLANK	28480	04193-26516

See introduction to this section for ordering information
 *Indicates factory selected value

Table 6-3. Replaceable Parts

Reference Designation	HP Part Number	C D	Qty	Description	Mfr Code	Mfr Part Number
A17						
A17	04193-66517	0	1	CONTROL LOGIC BOARD ASSEMBLY	20400	04193-66517
A17C1	0100-1083	3	4	CAPACITOR-FXD 330F 25VDC AL	20400	0100-1083
A17C2	0160-0127	2	3	CAPACITOR-FXD 10F +-20% 25VDC CER	20400	0160-0127
A17C3	0160-0127	2	2	CAPACITOR-FXD 10F +-20% 25VDC CER	20400	0160-0127
A17C4	0160-4035	7	2	CAPACITOR-FXD .10F +-10% 50VDC CER	20400	0160-4035
A17C5	0160-2266	4	2	CAPACITOR-FXD 24PF +-5% 50VDC CER 0+-30	20400	0160-2266
A17C6	0160-2009	4	7	CAPACITOR-FXD 820PF +-5% 50VDC CER 0+-30	20400	
A17C7	0160-4035	7	4	CAPACITOR-FXD .10F +-10% 50VDC CER	20400	0160-4035
A17C8	0100-1083	3	3	CAPACITOR-FXD 330F 25VDC AL	20400	0100-1083
A17C9	0160-0127	2	2	CAPACITOR-FXD 10F +-20% 25VDC CER	20400	0160-0127
A17C10	0100-1083	3	3	CAPACITOR-FXD 330F 25VDC AL	20400	0100-1083
A17C11	0100-1083	3	3	CAPACITOR-FXD 330F 25VDC AL	20400	0100-1083
A17C12	0100-0229	7	2	CAPACITOR-FXD 330F+-10% 15VDC TA	56259	150D336X901352
A17C13	0100-0229	7	2	CAPACITOR-FXD 330F+-10% 15VDC TA	56209	150D336X901607
A17CR1	1901-0040	1	3	DIODE-SWITCHING 30V 50MA PMS DO-35	20400	1901-0040
A17CR2	1901-0510	0	2	DIODE-SM STD SCHOTTKY	20400	1901-0510
A17CR3	1901-0510	0	2	DIODE-SM STD SCHOTTKY	20400	1901-0510
A17CR4	1901-0040	1	1	DIODE-SWITCHING 30V 50MA PMS DO-35	20400	1901-0040
A17CR5	1901-0040	1	1	DIODE-SWITCHING 30V 50MA PMS DO-35	20400	1901-0040
A17CR6	1902-0041	4	1	DIODE-ZNR 5.11V 5Z DO-35 PD=.4W	20400	1902-0041
A17J1	1200-0541	1	5	SOCKET-IC 24 CONT DIP DIP-SLDR	20400	1200-0541
A17J2	1200-0541	1	1	SOCKET-IC 24 CONT DIP DIP-SLDR	20400	1200-0541
A17J3	1200-0541	1	1	SOCKET-IC 24 CONT DIP DIP-SLDR	20400	1200-0541
A17J4	1200-0541	1	1	SOCKET-IC 24 CONT DIP DIP-SLDR	20400	1200-0541
A17J5	1200-0541	1	1	SOCKET-IC 24 CONT DIP DIP-SLDR	20400	1200-0541
A17J6	1200-0607	0	1	SOCKET-IC 16 CONT DIP DIP-SLDR	20400	1200-0607
A17J7	1200-0654	7	1	SOCKET-IC 40 CONT DIP DIP-SLDR	20400	1200-0654
A17L1	9100-3139	5	1	INDUCTOR 75UH 15% .50X.075LG	20400	9100-3139
A17Q1	1053-0015	7	2	TRANSISTOR PNP SI PD=200MW FT=500MHZ	20400	1053-0015
A17Q2	1053-0015	7	2	TRANSISTOR PNP SI PD=200MW FT=500MHZ	20400	1053-0015
A17R1	0683-0279	5	3	NETWORK-RES 10-51P4.7K OHM X 9	01121	210A472
A17R2	0683-2245	7	1	RESISTOR 220K 5% .25W FC TC=-400/+500	01121	068245
A17R3	0683-4725	2	4	RESISTOR 4.7K 5% .25W FC TC=-400/+500	01121	068475
A17R4	0683-5645	7	1	RESISTOR 560K 5% .25W FC TC=-400/+500	01121	068545
A17R5	0683-1515	2	2	RESISTOR 150 5% .25W FC TC=-400/+500	01121	068155
A17R6	0683-0715	6	2	RESISTOR 270 5% .25W FC TC=-400/+500	01121	068215
A17R7	0683-1205	7	2	RESISTOR 12 5% .25W FC TC=-400/+500	01121	068125
A17R8	0683-2205	9	2	RESISTOR 22 5% .25W FC TC=-400/+500	01121	068205
A17R9	0683-1515	2	2	RESISTOR 150 5% .25W FC TC=-400/+500	01121	068155
A17R10	0683-0715	6	2	RESISTOR 270 5% .25W FC TC=-400/+500	01121	068215
A17R11	0683-1205	7	2	RESISTOR 12 5% .25W FC TC=-400/+500	01121	068125
A17R12	0683-2205	9	2	RESISTOR 22 5% .25W FC TC=-400/+500	01121	068205
A17R13	0683-3315	4	2	RESISTOR 330 5% .25W FC TC=-400/+500	01121	068315
A17R14	0683-3315	4	2	RESISTOR 330 5% .25W FC TC=-400/+500	01121	068315
A17R15	0683-4725	2	2	RESISTOR 4.7K 5% .25W FC TC=-400/+500	01121	068475
A17R16	0683-4725	2	2	RESISTOR 4.7K 5% .25W FC TC=-400/+500	01121	068475
A17R17	1010-0279	5	1	NETWORK-RES 10-51P4.7K OHM X 9	01121	210A472
A17R18	0683-4725	2	2	RESISTOR 4.7K 5% .25W FC TC=-400/+500	01121	068475
A17R19	1010-0279	5	1	NETWORK-RES 10-51P4.7K OHM X 9	01121	210A472
A17S1	3101-1056	5	1	SWITCH-SLIDE B-1A	20400	3101-1056
A17S2	3101-0060	9	1	SWITCH-SLIDE DPDT-NS	20400	3101-0060
A17U1	1010-0430	4	2	IC NMOS 4096 (4K) RAM STAT 450-NS 3-0	01295	1002114-450N
A17U2	1010-0430	4	2	IC NMOS 4096 (4K) RAM STAT 450-NS 3-5	01295	1002114-450N
A17U3	04193-05001	5	1	IC-PROGRAMMED (PRGM)	20400	04193-05001
A17U4	04193-05002	6	1	IC-PROGRAMMED (PRGM)	20400	04193-05002
A17U5	04193-05003	7	1	IC-PROGRAMMED (PRGM)	20400	04193-05003
A17U6	04193-05004	0	1	IC-PROGRAMMED (PRGM)	20400	04193-05004
A17U7	04193-05005	9	1	IC-PROGRAMMED (PRGM)	20400	04193-05005
A17U8	1020-1216	3	4	IC DCDR TTL LS 3-TO-8-LINE 3-IMP	01295	SN741 S130N
A17U9	1020-1199	1	2	IC INV TTL LS HEX 1-IMP	01295	SN741 S04N
A17U10	1020-1216	3	3	IC DCDR TTL LS 3-TO-8-LINE 3-IMP	01295	SN741 S130N
A17U11	1020-1197	9	1	IC GATE TTL LS NAND QUAD 2-IMP	01295	SN741 S02N
A17U12	1020-0100	0	1	IC TIMER TTL MONO/ASTBL	01295	NE555P
A17U13	1020-1144	6	1	IC GATE TTL LS NOR QUAD 2-IMP	01295	SN741 S02N
A17U14	1020-1199	1	1	IC INV TTL LS HEX 1-IMP	01295	SN741 S04N
A17U15	1020-1216	3	3	IC DCDR TTL LS 3-TO-8-LINE 3-IMP	01295	SN741 S130N
A17U16	1020-1112	0	1	IC FF TTL LS D-TYPE POS-EDGE TRIG	01295	SN741 S74AN
A17U17	1020-1204	9	1	IC GATE TTL LS NAND DUAL 4-IMP	01295	SN741 S02N
A17U18	1020-2025	4	1	IC MISC TTL LS	01295	SN741 S245N
A17U19	1020-1400	3	1	IC MICROPROC NMRG 0-BIT	04713	MP4000L
A17U20	1020-2024	3	6	IC DRVR TTL LS LINE DRVR OCTL	01295	SN741 S244N

See introduction to this section for ordering information
 *Indicates factory selected value

Table 6-3. Replaceable Parts

Reference Designation	HP Part Number	C D	Qty	Description	Mfr Code	Mfr Part Number
A17U21	1820-1196	8	3	IC FF TTL LS D-TYPE POS-EDGE-TRIG COM	01295	SN74LS174N
A17U22	1820-1196	8		IC FF TTL LS D-TYPE POS-EDGE-TRIG COM	01295	SN74LS174N
A17U23	1820-1196	8		IC FF TTL LS D-TYPE POS-EDGE-TRIG COM	01295	SN74LS174N
A17U24	1820-1730	6	2	IC FF TTL LS D-TYPE POS-EDGE-TRIG COM	01295	SN74LS273N
A17U25	1820-1730	6		IC FF TTL LS D-TYPE POS-EDGE-TRIG COM	01295	SN74LS273N
A17U26	1820-2024	3		IC DRVR TTL LS LINE DRVR OCTL	01295	SN74LS244N
A17U27	1820-2024	3		IC DRVR TTL LS LINE DRVR OCTL	01295	SN74LS244N
A17U28	1820-1416	5	1	IC SCHMITT-TRIG TTL LS INV HEX 1-INP	01295	SN74LS14N
A17U29	1820-1216	3		IC DCDR TTL LS 3-TO-8-LINE 3-INP	01295	SN74LS138N
A17U30	1820-2024	3		IC DRVR TTL LS LINE DRVR OCTL	01295	SN74LS244N
A17U31	1820-2024	3		IC DRVR TTL LS LINE DRVR OCTL	01295	SN74LS244N
A17U32	1820-2024	3		IC DRVR TTL LS LINE DRVR OCTL	01295	SN74LS244N
A17W1	1251-4787	2	1	SHORT-DIP 8-POSITION	28480	1251-4787
	04193-26517	0	1	PCBD BLANK	28480	04193-26517

See introduction to this section for ordering information
 *Indicates factory selected value

Table 6-3. Replaceable Parts

Reference Designation	HP Part Number	C D	Qty	Description	Mfr Code	Mfr Part Number
A18						
A18	04193-66518	9	1	DISPLAY BOARD ASSEMBLY	28480	04193-66518
A18C1	0160-4835	7	1	CAPACITOR-FXD .10UF +-10% 50VDC CER	28480	0160-4835
A18C2	0160-0162	5	1	CAPACITOR-FXD .022UF +-10% 200VDC POLYE	28480	0160-0162
A18C3	0160-4801	7	1	CAPACITOR-FXD 100PF +-5% 100VDC CER	28480	0160-4801
A18C4	0160-4810	8	1	CAPACITOR-FXD 330PF +-5% 100VDC CER	28480	0160-4810
A18C5	0180-1083	3	7	CAPACITOR-FXD 33UF 25VDC AL	28480	0180-1083
A18C6	0180-1083	3		CAPACITOR-FXD 33UF 25VDC AL	28480	0180-1083
A18C7	0180-1083	3		CAPACITOR-FXD 33UF 25VDC AL	28480	0180-1083
A18C8	0180-1083	3		CAPACITOR-FXD 33UF 25VDC AL	28480	0180-1083
A18C9	0180-1083	3		CAPACITOR-FXD 33UF 25VDC AL	28480	0180-1083
A18C10	0180-1083	3		CAPACITOR-FXD 33UF 25VDC AL	28480	0180-1083
A18C11	0180-1083	3		CAPACITOR-FXD 33UF 25VDC AL	28480	0180-1083
A18C12	0160-4822	2	1	CAPACITOR-FXD 1000PF +-5% 100VDC CER	28480	0160-4822
A18C13	0180-0229	7	2	CAPACITOR-FXD 33UF+-10% 15VDC TA	56269	150D336X9010B2
A18C14	0180-0229	7		CAPACITOR-FXD 33UF+-10% 10VDC TA	56289	150D336X9010B2
A18C15	0180-2207	5	1	CAPACITOR-FXD 100UF+-10% 10VDC TA	56259	150D107X9010R2
A18C16	0160-4830	2	1	CAPACITOR-FXD 2200PF +-10% 100VDC CER	28480	0160-4830
A18CR1	1901-0040	1	2	DIODE-SWITCHING 30V 50MA 2NS DO-35	28480	1901-0040
A18CR2	1901-0040	1		DIODE-SWITCHING 30V 50MA 2NS DO-35	28480	1901-0040
A18DS1	1990-0486	6	9	LED-LAMP LUM-INT=1MCD IF=20MA-MAX BUR=5V	28480	5082-4684
A18DS2	1990-0486	6		LED-LAMP LUM-INT=1MCD IF=20MA-MAX BUR=5V	28480	5082-4684
A18DS3	1990-0486	6		LED-LAMP LUM-INT=1MCD IF=20MA-MAX BUR=5V	28480	5082-4684
A18DS4	1990-0486	6		LED-LAMP LUM-INT=1MCD IF=20MA-MAX BUR=5V	28480	5082-4684
A18DS5	1990-0486	6		LED-LAMP LUM-INT=1MCD IF=20MA-MAX BUR=5V	28480	5082-4684
A18DS6	1990-0486	6		LED-LAMP LUM-INT=1MCD IF=20MA-MAX BUR=5V	28480	5082-4684
A18DS7	1990-0486	6		LED-LAMP LUM-INT=1MCD IF=20MA-MAX BUR=5V	28480	5082-4684
A18DS8	1990-0540	3	8	DISPLAY-NUM-SEG 1-CHAR .43-H	28480	5082-7650
A18DS9	1990-0540	3		DISPLAY-NUM-SEG 1-CHAR .43-H	28480	5082-7650
A18DS10	1990-0540	3		DISPLAY-NUM-SEG 1-CHAR .43-H	28480	5082-7650
A18DS11	1990-0540	3		DISPLAY-NUM-SEG 1-CHAR .43-H	28480	5082-7650
A18DS12	1990-0486	6		LED-LAMP LUM-INT=1MCD IF=20MA-MAX BUR=5V	28480	5082-4684
A18DS13	1990-0486	6		LED-LAMP LUM-INT=1MCD IF=20MA-MAX BUR=5V	28480	5082-4684
A18DS14	1990-0540	3		DISPLAY-NUM-SEG 1-CHAR .43-H	28480	5082-7650
A18DS15	1990-0540	3		DISPLAY-NUM-SEG 1-CHAR .43-H	28480	5082-7650
A18DS16	1990-0540	3		DISPLAY-NUM-SEG 1-CHAR .43-H	28480	5082-7650
A18DS17	1990-0540	3		DISPLAY-NUM-SEG 1-CHAR .43-H	28480	5082-7650
A18DS18	1990-0531	2	4	DISPLAY-NUM-SEG 1-CHAR .3-H	28480	5082-7610
A18DS19	1990-0531	2		DISPLAY-NUM-SEG 1-CHAR .3-H	28480	5082-7610
A18DS20	1990-0531	2		DISPLAY-NUM-SEG 1-CHAR .3-H	28480	5082-7610
A18DS21	1990-0531	2		DISPLAY-NUM-SEG 1-CHAR .3-H	28480	5082-7610
A18DS22	1990-0665	3	16	LED-LAMP LUM-INT=1MCD IF=20MA-MAX BUR=5V	28480	1990-0665
A18DS23	1990-0665	3		LED-LAMP LUM-INT=1MCD IF=20MA-MAX BUR=5V	28480	1990-0665
A18DS24	1990-0665	3		LED-LAMP LUM-INT=1MCD IF=20MA-MAX BUR=5V	28480	1990-0665
A18DS25	1990-0665	3		LED-LAMP LUM-INT=1MCD IF=20MA-MAX BUR=5V	28480	1990-0665
A18DS26	1990-0665	3		LED-LAMP LUM-INT=1MCD IF=20MA-MAX BUR=5V	28480	1990-0665
A18DS27	1990-0665	3		LED-LAMP LUM-INT=1MCD IF=20MA-MAX BUR=5V	28480	1990-0665
A18DS28	1990-0665	3		LED-LAMP LUM-INT=1MCD IF=20MA-MAX BUR=5V	28480	1990-0665
A18DS29	1990-0665	3		LED-LAMP LUM-INT=1MCD IF=20MA-MAX BUR=5V	28480	1990-0665
A18DS30	1990-0665	3		LED-LAMP LUM-INT=1MCD IF=20MA-MAX BUR=5V	28480	1990-0665
A18DS31	1990-0665	3		LED-LAMP LUM-INT=1MCD IF=20MA-MAX BUR=5V	28480	1990-0665
A18DS32	1990-0665	3		LED-LAMP LUM-INT=1MCD IF=20MA-MAX BUR=5V	28480	1990-0665
A18DS33	1990-0665	3		LED-LAMP LUM-INT=1MCD IF=20MA-MAX BUR=5V	28480	1990-0665
A18DS34	1990-0665	3		LED-LAMP LUM-INT=1MCD IF=20MA-MAX BUR=5V	28480	1990-0665
A18DS35	1990-0665	3		LED-LAMP LUM-INT=1MCD IF=20MA-MAX BUR=5V	28480	1990-0665
A18DS36	1990-0665	3		LED-LAMP LUM-INT=1MCD IF=20MA-MAX BUR=5V	28480	1990-0665
A18DS37	1990-0665	3		LED-LAMP LUM-INT=1MCD IF=20MA-MAX BUR=5V	28480	1990-0665
A18J1	1200-0638	6	1	CABLE-TRANSITION	28480	0760-1901
A18J2	1200-0638	7	12	SOCKET-IC 14-CONT DIP DIP-SLDR	28480	1200-0638
A18J3	1200-0638	7		SOCKET-IC 14-CONT DIP DIP-SLDR	28480	1200-0638
A18J4	1200-0638	7		SOCKET-IC 14-CONT DIP DIP-SLDR	28480	1200-0638
A18J5	1200-0638	7		SOCKET-IC 14-CONT DIP DIP-SLDR	28480	1200-0638
A18J6	1200-0638	7		SOCKET-IC 14-CONT DIP DIP-SLDR	28480	1200-0638
A18J7	1200-0638	7		SOCKET-IC 14-CONT DIP DIP-SLDR	28480	1200-0638
A18J8	1200-0638	7		SOCKET-IC 14-CONT DIP DIP-SLDR	28480	1200-0638
A18J9	1200-0638	7		SOCKET-IC 14-CONT DIP DIP-SLDR	28480	1200-0638
A18J10	1200-0638	7		SOCKET-IC 14-CONT DIP DIP-SLDR	28480	1200-0638
A18J11	1200-0638	7		SOCKET-IC 14-CONT DIP DIP-SLDR	28480	1200-0638
A18J12	1200-0638	7		SOCKET-IC 14-CONT DIP DIP-SLDR	28480	1200-0638
A18J13	1200-0638	7		SOCKET-IC 14-CONT DIP DIP-SLDR	28480	1200-0638
A18L1	9100-3139	5	1	COIL 75UH 15Z	28480	9100-3139
A18Q1	1853-0318	3	15	TRANSISTOR PNP SI PD=500MW FT=60MHZ	04713	MP56562
A18Q2	1853-0318	3		TRANSISTOR PNP SI PD=500MW FT=60MHZ	04713	MP56562
A18Q3	1853-0318	3		TRANSISTOR PNP SI PD=500MW FT=60MHZ	04713	MP56562
A18Q4	1853-0318	3		TRANSISTOR PNP SI PD=500MW FT=60MHZ	04713	MP56562
A18Q5	1853-0318	3		TRANSISTOR PNP SI PD=500MW FT=60MHZ	04713	MP56562
A18Q6	1853-0318	3		TRANSISTOR PNP SI PD=500MW FT=60MHZ	04713	MP56562
A18Q7	1853-0318	3		TRANSISTOR PNP SI PD=500MW FT=60MHZ	04713	MP56562
A18Q8	1853-0318	3		TRANSISTOR PNP SI PD=500MW FT=60MHZ	04713	MP56562
A18Q9	1853-0318	3		TRANSISTOR PNP SI PD=500MW FT=60MHZ	04713	MP56562
A18Q10	1853-0318	3		TRANSISTOR PNP SI PD=500MW FT=60MHZ	04713	MP56562

See introduction to this section for ordering information
 *Indicates factory selected value

Table 6-3. Replaceable Parts

Reference Designation	HP Part Number	C D	Qty	Description	Mfr Code	Mfr Part Number
A18Q11	1853-0318	3		TRANSISTOR PNP SI PD=500MW FT=60MHZ	04713	MPS6562
A18Q12	1853-0318	3		TRANSISTOR PNP SI PD=500MW FT=60MHZ	04713	MPS6562
A18Q13	1853-0318	3		TRANSISTOR PNP SI PD=500MW FT=60MHZ	04713	MPS6562
A18Q14	1853-0318	3		TRANSISTOR PNP SI PD=500MW FT=60MHZ	04713	MPS6562
A18Q15	1853-0318	3		TRANSISTOR PNP SI PD=500MW FT=60MHZ	04713	MPS6562
A18Q16	1854-0071	7	8	TRANSISTOR NPN SI PD=300MW FT=200MHZ	28480	1854-0071
A18Q17	1854-0071	7		TRANSISTOR NPN SI PD=300MW FT=200MHZ	28480	1854-0071
A18Q18	1854-0071	7		TRANSISTOR NPN SI PD=300MW FT=200MHZ	28480	1854-0071
A18Q19	1854-0071	7		TRANSISTOR NPN SI PD=300MW FT=200MHZ	28480	1854-0071
A18Q20	1854-0071	7		TRANSISTOR NPN SI PD=300MW FT=200MHZ	28480	1854-0071
A18Q21	1854-0071	7		TRANSISTOR NPN SI PD=300MW FT=200MHZ	28480	1854-0071
A18Q22	1854-0071	7		TRANSISTOR NPN SI PD=300MW FT=200MHZ	28480	1854-0071
A18Q23	1854-0071	7		TRANSISTOR NPN SI PD=300MW FT=200MHZ	28480	1854-0071
A18R1	0683-3315	4	7	RESISTOR 330 5% .25W FC TC=-400/+600	01121	CB3315
A18R2	0683-3315	4		RESISTOR 330 5% .25W FC TC=-400/+600	01121	CB3315
A18R3	0683-3315	4		RESISTOR 330 5% .25W FC TC=-400/+600	01121	CB3315
A18R4	0683-3315	4		RESISTOR 330 5% .25W FC TC=-400/+600	01121	CB3315
A18R5	0683-3315	4		RESISTOR 330 5% .25W FC TC=-400/+600	01121	CB3315
A18R6	0683-3315	4		RESISTOR 330 5% .25W FC TC=-400/+600	01121	CB3315
A18R7	0683-3315	4		RESISTOR 330 5% .25W FC TC=-400/+600	01121	CB3315
A18R8	0683-1025	9	2	RESISTOR 1K 5% .25W FC TC=-400/+600	01121	CB1025
A18R9	0683-1025	9	3	RESISTOR 1K 5% .25W FC TC=-400/+600	01121	CB1025
A18R10	0683-4715	0	4	RESISTOR 470 5% .25W FC TC=-400/+600	01121	CB4715
A18R11	0683-3305	2	8	RESISTOR 33 5% .25W FC TC=-400/+500	01121	CB3305
A18R12	0683-3305	2		RESISTOR 33 5% .25W FC TC=-400/+500	01121	CB3305
A18R13	0683-3305	2		RESISTOR 33 5% .25W FC TC=-400/+500	01121	CB3305
A18R14	0683-3305	2		RESISTOR 33 5% .25W FC TC=-400/+500	01121	CB3305
A18R15	0683-3305	2		RESISTOR 33 5% .25W FC TC=-400/+500	01121	CB3305
A18R16	0683-3305	2		RESISTOR 33 5% .25W FC TC=-400/+500	01121	CB3305
A18R17	0683-3305	2		RESISTOR 33 5% .25W FC TC=-400/+500	01121	CB3305
A18R18	0683-3305	2		RESISTOR 33 5% .25W FC TC=-400/+500	01121	CB3305
A18R19	1810-0275	1	3	NETWORK-RES 18-SIP1.0K OHM X 9	01121	210A102
A18R20	1810-0275	1		NETWORK-RES 18-SIP1.0K OHM X 9	01121	210A102
A18R21	1810-0283	1	2	NETWORK-RES 16-DIP270.0 OHM X 8	28480	1810-0283
A18R22	0683-2235	5	1	RESISTOR 22K 5% .25W FC TC=-400/+600	01121	CB2235
A18R23	0683-1045	3	1	RESISTOR 100K 5% .25W FC TC=-400/+600	01121	CB1045
A18R24	1810-0275	1		NETWORK-RES 18-SIP1.0K OHM X 9	01121	210A102
A18R25	1810-0283	1		NETWORK-RES 16-DIP270.0 OHM X 8	28480	1810-0283
A18R26	1810-0279	5	3	NETWORK-RES 18-SIP4.7K OHM X 9	01121	210A472
A18R27	1810-0279	5		NETWORK-RES 18-SIP4.7K OHM X 9	01121	210A472
A18R28	1810-0279	5		NETWORK-RES 18-SIP4.7K OHM X 9	01121	210A472
A18R29	0683-1515	7	1	RESISTOR 150 5% .25W FC TC=-400/+500	01121	CB1515
A18R30	0683-1515	2	1	RESISTOR 150 5% .25W FC TC=-400/+500	01121	CB1515
A18R31	0683-4715	0		RESISTOR 470 5% .25W FC TC=-400/+600	01121	CB4715
A18R32	0683-4715	0		RESISTOR 470 5% .25W FC TC=-400/+600	01121	CB4715
A18R33	0683-4715	0		RESISTOR 470 5% .25W FC TC=-400/+600	01121	CB4715
A18S1	5060-9436	7	23	PUSHBUTTON SWITCH P.C. MOUNT	28480	5060-9436
A18S2	5060-9436	7		PUSHBUTTON SWITCH P.C. MOUNT	28480	5060-9436
A18S3	5060-9436	7		PUSHBUTTON SWITCH P.C. MOUNT	28480	5060-9436
A18S4	5060-9436	7		PUSHBUTTON SWITCH P.C. MOUNT	28480	5060-9436
A18S5	5060-9436	7		PUSHBUTTON SWITCH P.C. MOUNT	28480	5060-9436
A18S6	5060-9436	7		PUSHBUTTON SWITCH P.C. MOUNT	28480	5060-9436
A18S7	5060-9436	7		PUSHBUTTON SWITCH P.C. MOUNT	28480	5060-9436
A18S8	5060-9436	7		PUSHBUTTON SWITCH P.C. MOUNT	28480	5060-9436
A18S9	5060-9436	7		PUSHBUTTON SWITCH P.C. MOUNT	28480	5060-9436
A18S10	5060-9436	7		PUSHBUTTON SWITCH P.C. MOUNT	28480	5060-9436
A18S11	5060-9436	7		PUSHBUTTON SWITCH P.C. MOUNT	28480	5060-9436
A18S12	5060-9436	7		PUSHBUTTON SWITCH P.C. MOUNT	28480	5060-9436
A18S13	5060-9436	7		PUSHBUTTON SWITCH P.C. MOUNT	28480	5060-9436
A18S14	5060-9436	7		PUSHBUTTON SWITCH P.C. MOUNT	28480	5060-9436
A18S15	5060-9436	7		PUSHBUTTON SWITCH P.C. MOUNT	28480	5060-9436
A18S16	5060-9436	7		PUSHBUTTON SWITCH P.C. MOUNT	28480	5060-9436
A18S17	5060-9436	7		PUSHBUTTON SWITCH P.C. MOUNT	28480	5060-9436
A18S18	5060-9436	7		PUSHBUTTON SWITCH P.C. MOUNT	28480	5060-9436
A18S19	5060-9436	7		PUSHBUTTON SWITCH P.C. MOUNT	28480	5060-9436
A18S20	5060-9436	7		PUSHBUTTON SWITCH P.C. MOUNT	28480	5060-9436
A18S21	5060-9436	7		PUSHBUTTON SWITCH P.C. MOUNT	28480	5060-9436
A18S22	5060-9436	7		PUSHBUTTON SWITCH P.C. MOUNT	28480	5060-9436
A18S23	5060-9436	7		PUSHBUTTON SWITCH P.C. MOUNT	28480	5060-9436
A18U1	1826-0180	0	1	IC TIMER TTL MONO/ASTBL	01295	NE555P
A18U2	1820-0495	8	1	IC DCOR TTL 4-10-16-LINE 4-INP	01295	SN74154N
A18U3	1820-1423	4	1	IC MV TTL LS MONOSTBL RETRIC DUAL	01295	SN7415123N
A18U4	1820-1197	9	1	IC GATE TTL LS NAND QUAD 2-INP	01295	SN74LS00N
A18U5	1820-1851	2	3	IC ENCOD TTL LS	01295	SN7415148N

See introduction to this section for ordering information
 *Indicates factory selected value

Table 6-3. Replaceable Parts

Reference Designation	HP Part Number	C D	Qty	Description	Mfr Code	Mfr Part Number
A18U6	1820-1851	2		IC ENCDR TTL LS	01295	SN74LS148N
A18U7	1820-1851	2		IC ENCDR TTL LS	01295	SN74LS149N
A18U8	1820-1278	7	1	IC CNTR TTL LS BDN UP/DOWN SYNCHRO	01295	SN74LS191N
A18U9	1820-0628	9	2	IC TTL 64-BIT RAM STAT 60-INS 0-C	01295	SN7489N
A18U10	1820-0628	9		IC TTL 64-BIT RAM STAT 60-INS 0-C	01295	SN7489N
A18U11	1820-1425	6	2	IC SCHMITT-TRIG TTL LS NAND QUAD 2-IMP	01295	SN74LS132N
A18U12	1820-1204	9	1	IC GATE TTL LS NAND DUAL 4-IMP	01295	SN74LS20N
A18U13	1820-1199	1	1	IC INV TTL LS HEX 1-IMP	01295	SN74LS04N
A18U14	1820-1202	7	2	IC GATE TTL LS NAND TPL 3-IMP	01295	SN74LS10N
A18U15	1820-1203	8	1	IC GATE TTL LS AND TPL 3-IMP	01295	SN74LS11N
A18U16	1820-1202	7		IC GATE TTL LS NAND TPL 3-IMP	01295	SN74LS10N
A18U17	1820-1206	5	1	IC INV TTL LS HEX	01295	SN74LS05N
A18U18	1820-1997	7	1	IC FF TTL LS D-TYPE POS-EDGE-TRIG PRL-IN	01295	SN74LS374N
A18U19	1820-1730	6	1	IC FF TTL LS D-TYPE POS-EDGE-TRIG CON	01295	SN74LS273N
A18U20	1820-1425	6		IC SCHMITT-TRIG TTL LS NAND QUAD 2-IMP	01295	SN74LS132N
A18U21	1820-1112	8	3	IC FF TTL LS D-TYPE POS-EDGE-TRIG	01295	SN74LS74AN
A18U22	1820-1112	8		IC FF TTL LS D-TYPE POS-EDGE-TRIG	01295	SN74LS74AN
A18U23	1820-1112	8		IC FF TTL LS D-TYPE POS-EDGE-TRIG	01295	SN74LS74AN
A18W1	04193-61601	1	1	CABLE ASSEMBLY-FLAT	28480	04193-61601
	1460-0249	0	1	CABLE TIE .062-.625-DIA .091-WD NYL	06393	PL11M-8
	5040-3322	6	8	INSULATOR	28480	5040-3322
	5041-0276	5	2	KEY CAP-PEARL GRAY	28480	5041-0276
	5041-0265	6	8	KEY CAP-QUARTER LIGHT GRAY	28480	5041-0265
	5041-0318	6	4	KEY CAP	28480	5041-0318
	5041-0375	5	2	KEY CAP-QUARTER SMK	28480	5041-0375
	5041-0384	6	3	KEY CAP-QUARTER SMOKE GRAY	28480	5041-0384
	5041-0408	5	1	KEY CAP	28480	5041-0408
	5041-0450	7	1	KEY CAP	28480	5041-0450
	5041-0922	8	2	KEY CAP-QUARTER EBY-PRL	28480	5041-0922
	5060-9444	7	1	ROTARY PULSE GENERATOR	28480	5060-9444
	04193-26518		1	PCBD BLANK	28480	04193-26518

See introduction to this section for ordering information
 *Indicates factory selected value

Table 6-3. Replaceable Parts

Reference Designation	HP Part Number	C D	Qty	Description	Mfr Code	Mfr Part Number
A20						
A20	04193-66520	3	1	POWER SUPPLY BOARD ASSEMBLY	28490	04193-66520
A20C1	0180-3180	4	2	CAPACITOR-FXD 1000UF 16VDC	28480	0180-3180
A20C2	0180-3180	4	4	CAPACITOR-FXD 1000UF 16VDC	28480	0180-3180
A20C3	0180-3181	5	1	CAPACITOR-FXD 6800UF 35VDC	28480	0180-3181
A20C4	0180-1075	3	1	CAPACITOR-FXD 2200 UF 16VDC AL	28480	0180-1075
A20C5	0180-3183	7	2	CAPACITOR-FXD 470UF 50VDC	28480	0180-3183
A20C6	0180-2205	3	1	CAPACITOR-FXD .33UF+-10% 35VDC TA	56269	1500134X9035A2
A20C7	0180-0374	3	6	CAPACITOR-FXD 100UF+-10% 20VDC TA	56269	1501166X9020R2
A20C8	0180-0374	3	3	CAPACITOR-FXD 100UF+-10% 20VDC TA	56269	1500106X9023A2
A20C9	0180-0374	3	3	CAPACITOR-FXD 100UF+-10% 20VDC TA	56269	1501166X9020R2
A20C10	0180-0374	3	3	CAPACITOR-FXD 100UF+-10% 20VDC TA	56269	1500106X9020R2
A20C11	0180-0374	3	3	CAPACITOR-FXD 100UF+-10% 20VDC TA	56269	1501166X9020R2
A20C12	0180-0374	3	3	CAPACITOR-FXD 100UF+-10% 20VDC TA	56269	1501166X9020R2
A20C13	0160-4835	7	2	CAPACITOR-FXD .1UF+-10% 50VDC CER	28480	0160-4835
A20C14	0180-3182	6	1	CAPACITOR-FXD 2200UF 35VDC	28480	0180-3182
A20C15	0180-0291	3	1	CAPACITOR-FXD 1UF+-10% 35VDC TA	56269	1501165X9035A0
A20C16	0180-3183	7	7	CAPACITOR-FXD 420UF 50VDC	28480	0180-3183
A20C17	0180-2141	6	1	CAPACITOR-FXD 3.3UF+-10% 50VDC TA	56269	1501165X9035A0
A20C18	0160-4835	7	1	CAPACITOR-FXD .1UF+-10% 50VDC CER	28480	0160-4835
A20C19	0180-0291	3	2	CAPACITOR-FXD 1UF 35VDC TA		
A20C20	0180-0291	3	2	CAPACITOR-FXD 1UF 35VDC TA		
A20CR3	1901-0731	7	2	DIODE-PWR RECT 400V 1A	28480	1901-0731
A20CR4	1901-0731	7	2	DIODE-PWR RECT 400V 1A	28480	1901-0731
A20CR5	1901-0237	8	1	DIODE-SI, RECTIFIER BRIDGE, 200V	28480	1901-0237
A20CR6	1902-3086	3	1	DIODE-ZNR 4.75V 2% DO-35 PD=.4W	28480	1902-3086
A20CR7	1901-0646	1	2	DIODE-SWITCHING 30V 50MA 2NS DO-35	28480	1901-0646
A20CR8	1901-0940	1	1	DIODE-SWITCHING 30V 50MA 2NS DO-35	28480	1901-0940
A20CR9	1906-0096	7	1	DIODE-PW BRDG 200V 2A	04713	1906-0096
A20CR10	1902-3048	1	1	DIODE-ZNR 6.01V 5% DO-35 PD=.4W	28480	1902-3048
A20CR11	1902-1217	8	1	DIODE-ZNR 6.2V 5% DO-4 PD=10W TC=+.035%	28480	1902-1217
A20F1	2110-0007	4	2	FUSE 1A 250V TD 1.25X.25 UL	75915	313001
A20F2	2110-0061	0	1	FUSE .25A 250V TD 1.25X.25 UL	75915	313.250
A20F3	2110-0015	6	1	FUSE 2.5A 250V TD 1.25X.25	28480	2110-0015
A20F4	2110-0003	1	1	FUSE 3A 250V TD 1.25X.25	28480	2110-0003
A20F5	2110-0303	3	1	FUSE 2A 250V TD 1.25X.25 UL	28480	2110-0303
A20F6	2110-0007	4	4	FUSE 1A 250V TD 1.25X.25 UL	75915	313001
A20J1	1251-5862	6	8	CONNECTOR 4-PIN M METRIC POST TYPE	28480	1251-5862
A20J2	1251-5862	6	6	CONNECTOR 4-PIN M METRIC POST TYPE	28480	1251-5862
A20J5	1251-5862	6	6	CONNECTOR 4-PIN M METRIC POST TYPE	28480	1251-5862
A20J6	1251-5862	6	6	CONNECTOR 4-PIN M METRIC POST TYPE	28480	1251-5862
A20J7	1251-5862	6	6	CONNECTOR 4-PIN M METRIC POST TYPE	28480	1251-5862
A20J8	1251-5862	6	6	CONNECTOR 4-PIN M METRIC POST TYPE	28480	1251-5862
A20J9	1251-5862	6	6	CONNECTOR 4-PIN M METRIC POST TYPE	28480	1251-5862
A20J10	1251-5862	6	6	CONNECTOR 4-PIN M METRIC POST TYPE	28480	1251-5862
A20J11	1251-3198	7	1	CONNECTOR 15-PIN M POST TYPE	28480	1251-3198
A20J12	1251-3197	6	1	CONNECTOR 12-PIN M POST TYPE	28480	1251-3197
A20R1	0683-6825	7	4	RESISTOR 6.8K 5% .25W FC TC=+400/+700	01121	068825
A20R2	0698-7457	7	4	RESISTOR 18 2% 2W		
A20R3	0698-7457	7	4	RESISTOR 18 2% 2W		
A20R6	0698-3444	1	2	RESISTOR 316 1% .125W F TC=0+-100	24546	C4 1/8-T0-316R-F
A20R7	0683-3685	5	2	RESISTOR 6.8 5% .25W FC TC=+400/+500	01121	068825
A20R8	0698-3444	1	1	RESISTOR 316 1% .125W F TC=0+-100	24546	C4 1/8-T0-316R-F
A20R9	0683-3685	5	5	RESISTOR 6.8 5% .25W FC TC=+400/+500	01121	068825
A20R10	0757-0401	0	1	RESISTOR 100 1% .125W F TC=0+-100	24546	C4 1/8-T0-100R-F
A20R11	0757-0274	5	1	RESISTOR 1.21K 1% .125W F TC=0+-100	24546	C4 1/8-T0-1211 F
A20R12	0683-1025	5	1	RESISTOR 1K 1% .25W F TC=0+-100	03388	PH 55-1/8-T0-2185-F
A20R13	0683-4705	8	1	RESISTOR 47 5% .25W FC TC=+400/+500	01121	068825
A20R14	0683-6825	7	7	RESISTOR 6.8K 5% .25W FC TC=+400/+700	01121	068825
A20R15	0683-6825	7	7	RESISTOR 6.8K 5% .25W FC TC=+400/+700	01121	068825
A20R16	0683-1025	9	2	RESISTOR 1K 5% .25W FC TC=+400/+600	01121	068825
A20R17	0683-1535	6	1	RESISTOR 15K 5% .25W FC TC=+400/+900	01121	068825
A20R18	0683-2215	1	1	RESISTOR 220 5% .25W FC TC=+400/+600	01121	068825
A20R19	0683-6825	7	7	RESISTOR 6.8K 5% .25W FC TC=+400/+700	01121	068825
A20R20	0757-0398	4	1	RESISTOR 25 1% .125W F TC=0+-100	24546	C4 1/8-T0-2500-F
A20R21	0757-0277	8	1	RESISTOR 49.9 1% .125W F TC=0+-100	24546	C4 1/8-T0-4992 F
A20R22	0698-0624	7	1	RESISTOR 2.61K 1% .5W F TC=0+-100	28480	0698-0624
A20R23	0683-2225	3	1	RESISTOR 2.2K 5% .25W FC TC=+400/+700	01121	068825
A20R24	2100-3210	6	1	RESISTOR-TRMR 10K 10% C TO-ADJ 1 TRN	28480	2100-3210
A20R25	0757-0442	9	1	RESISTOR 15K 1% .125W F TC=0+-100	24546	C4 1/8-T0-1500 F
A20R26	0683-1825	9	9	RESISTOR 1.8K 5% .25W FC TC=+400/+600		
A20R27	0683-1825	9	9	RESISTOR 1.8K 5% .25W FC TC=+400/+600		

See introduction to this section for ordering information
 *Indicates factory selected value

Table 6-3. Replaceable Parts

Reference Designation	HP Part Number	C D	Qty	Description	Mfr Code	Mfr Part Number
A2001	1826-0215	2	1	IC V RGLTR TC-220	34713	MC7905.2CT
A2002	1826-0493	6	1	IC OP AMP GP 8-DIP-P PKG	27014	LM307N
A2003	1826-0527	9	1	TC 337 V RGLTR TC-220	27014	LM337T
A2004	1826-0065	0	1	IC COMPARTOR PRON 8-DIP-P PKG	01295	SN72311P
A2005	1826-0106		1	IC V RGLTR 7815		
	2110-0269	0	12	FUSEHOLDER-CLIP TYPE.25D-FUSE	28480	2110-0269
A20W3	8159-0005		1	JUMPER WIRE		
	04193-26520	0	1	PCBD BLANK	28480	04193-26520

See introduction to this section for ordering information
 *Indicates factory selected value

Table 6-3. Replaceable Parts

Reference Designation	HP Part Number	C D	Qty	Description	Mfr Code	Mfr Part Number
A41 A51 A52						
A41	04193-66541	8	1	DELAY BOARD ASSEMBLY	28480	04193-66541
	04193-26541	0	1	PCBD BLANK	28480	04193-26541
A51	04193-66551	0	1	PROBE I CHANNEL BOARD ASSEMBLY	28480	04193-66551
A51C1	9160-4249	7	2	CAPACITOR-FXD 4.7PF +-1.5% 50VDC CER	26654	36N650S4R7D(D)
A51CR1	5080-3829	8	8	DIODE-SM SIG SCHOTTKY	28480	5080-3829
A51CR2	5080-3829	8		DIODE-SM SIG SCHOTTKY	28480	5080-3829
A51CR3	5080-3829	8		DIODE-SM SIG SCHOTTKY	28480	5080-3829
A51CR4	5080-3829	8		DIODE-SM SIG SCHOTTKY	28480	5080-3829
A51Q1	1855-0465		4	TRANSISTOR-FET N-CHANNEL		
A51R1	0699-0920			RESISTOR-FXD 50 OHM 1% 1/16W		
A51T1	04193-61552	1	2	BALUN	28480	04193-61552
	04193-26551	0	1	PCBD BLANK	28480	04193-26551
A52	04193-66552	1	1	PROBE V CHANNEL BOARD ASSEMBLY	28480	04193-66552
A52C1	0160-4249	7		CAPACITOR-FXD 4.7PF +-1.5% 50VDC CER	26654	36N650S4R7D(D)
A52C2	0160-5427	3	1	CAPACITOR-FXD 0.1UF +-10% 100VDC	28480	0160-5427
A52CR1	5080-3829	8		DIODE-SM SIG SCHOTTKY	28480	5080-3829
A52CR2	5080-3829	8		DIODE-SM SIG SCHOTTKY	28480	5080-3829
A52CR3	5080-3829	8		DIODE-SM SIG SCHOTTKY	28480	5080-3829
A52CR4	5080-3829	8		DIODE-SM SIG SCHOTTKY	28480	5080-3829
A52Q1	1855-0465			TRANSISTOR-FET N-CHANNEL		
A52R1	0699-0920			RESISTOR-50 OHM 1% 1/16W		
A52T1	04193-61552	1		BALUN	28480	04193-61552
	04193-26552	0	1	PCBD BLANK	28480	04193-26552

See introduction to this section for ordering information
 *Indicates factory selected value

Table 6-4. Parts Identification

Reference Designation	HP Part Number	Qty	Description	Mfr Code	Mfr Part Number
1	0370-3033	1	KNOB		
2	04193-00201	1	FRONT PANEL (HP)		
	04193-00202	1	FRONT PANEL (YHP)		
3	04262-40002	1	WINDOW		
4	04140-25001	1	WINDOW		
5	7120-1254	1	TRADE MARK (HP)		
	7120-0478	1	TRADE MARK (YHP)		
6	04193-40001	1	PROBE HOLDER		
7	04191-40001	1	GUIDE		
8	04193-24002	1	NUT		
9	04193-24001	1	NUT		
10	04193-21001	1	BODY RECEPTACLE		
11	5041-0564	1	KEY CAP		
12	5040-7201	4	FOOT		
13	5060-9847	1	BOTTOM COVER		
14	1460-1345	2	STAND		
15	04193-25101	1	ROD		
16	2510-0192	16	SCREW		
17	2360-0115	15	SCREW		
18	5040-7219	2	FRONT CAP		
19	2680-0172	4	SCREW		
20	5060-9804	2	HANDLE		
21	5060-9942	2	SIDE COVER		
22	2360-0115	4	SCREW		
23	2110-0569	1	NUT		
24	04192-40002	1	COUPLER		
25	3101-2216	1	POWER SWITCH		
26	3050-0235	2	WASHER (F)		
	2190-0225	2	WASHER (S)		
27	0515-0150	2	SCREW		
28	5040-7220	2	REAR CAP		
29	3160-0390	1	FAN		
30	9100-4176	1	TRANSFORMER		
31	2110-0564	1	FUSE HOLDER		
32	2110-0304	1	FUSE		
33	2110-0565	1	CAP		
34	5020-8806	1	REAR FRAME		
35	2510-0045	4	SCREW		
36	3050-0139	4	WASHER		
37	2360-0117	4	SCREW		
38	2420-0006	4	NUT		
39	04193-04001	1	COVER		
40	2360-0113	8	SCREW		
41	2740-0003	2	NUT		
42	3050-0226	2	WASHER		
43	1200-0080	4	INSULATOR		
44	0624-0260	10	SCREW		
45	2190-0008	10	WASHER		
46	5000-4207	1	SHORT BAR		
47	2190-0057	2	WASHER		
48	1901-0496	2	DIODE		
49	1250-0118	5	BNC CONNECTOR (FEMALE)		
50	2950-0035	1	NUT		
51	04271-50024	1	INSULATOR		
52	04193-60101	1	REAR PANEL		
53	2360-0113	8	SCREW		
54	04262-66503	1	HP-IB CONNECTOR		
55	2190-0016	8	WASHER		
56	2950-0001	5	NUT		
57	1250-0252	1	BNC CONNECTOR (FEMALE)		
58	04271-50025	1	INSULATOR		
59	04193-01204	1	ANGLE		
60	04193-00605	1	PLATE		
61	2360-0113	2	SCREW		
62	04193-01205	1	SUPPORT		
63	04193-01203	1	ANGLE		
64	2360-0113	3	SCREW		
65	5060-9835	1	TOP COVER		
66	2360-0333	6	SCREW		
67	5020-8805	1	FRONT FRAME		
68	04193-00203	1	SUB PANEL		
69	1826-0203	1	TRANSISTOR (U4)		
70	1826-0169	1	TRANSISTOR (U3)		
71	1820-0430	2	TRANSISTOR (U1 and U2)		
72	1854-0611	1	TRANSISTOR (Q1)		

See introduction to this section for ordering information

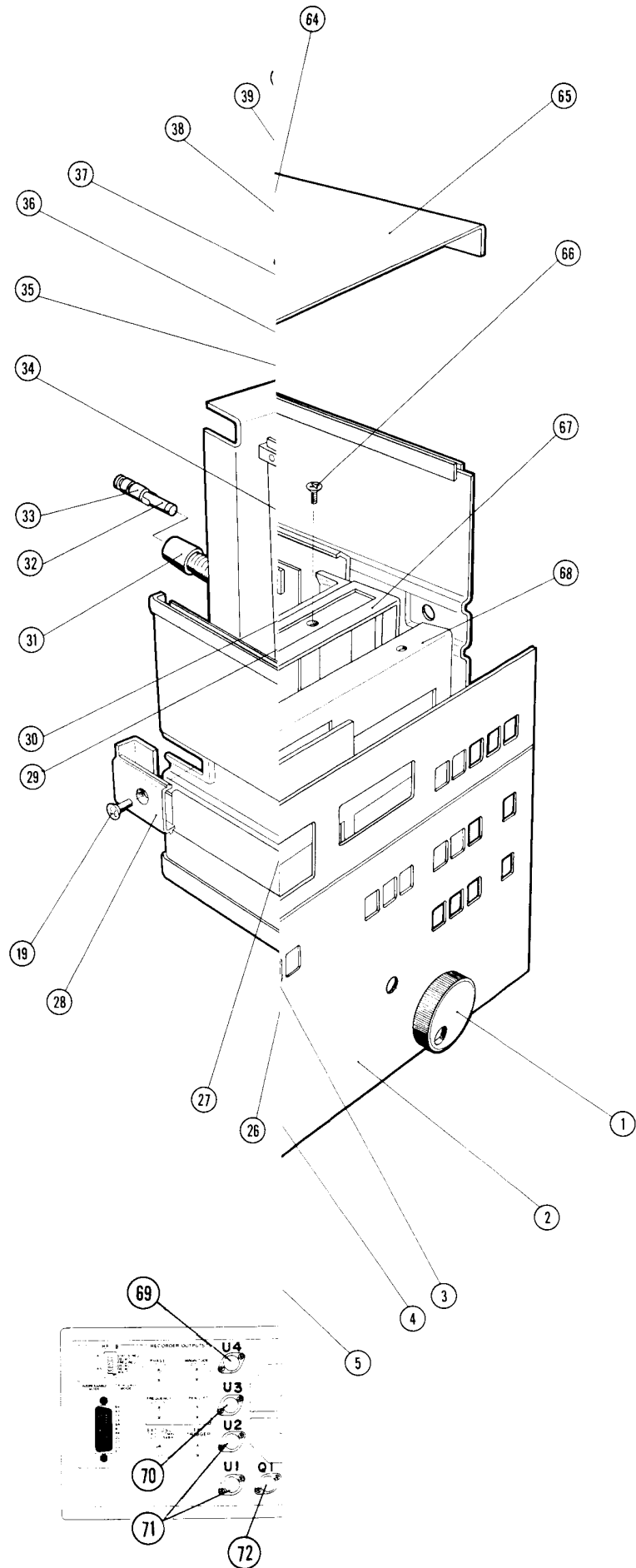

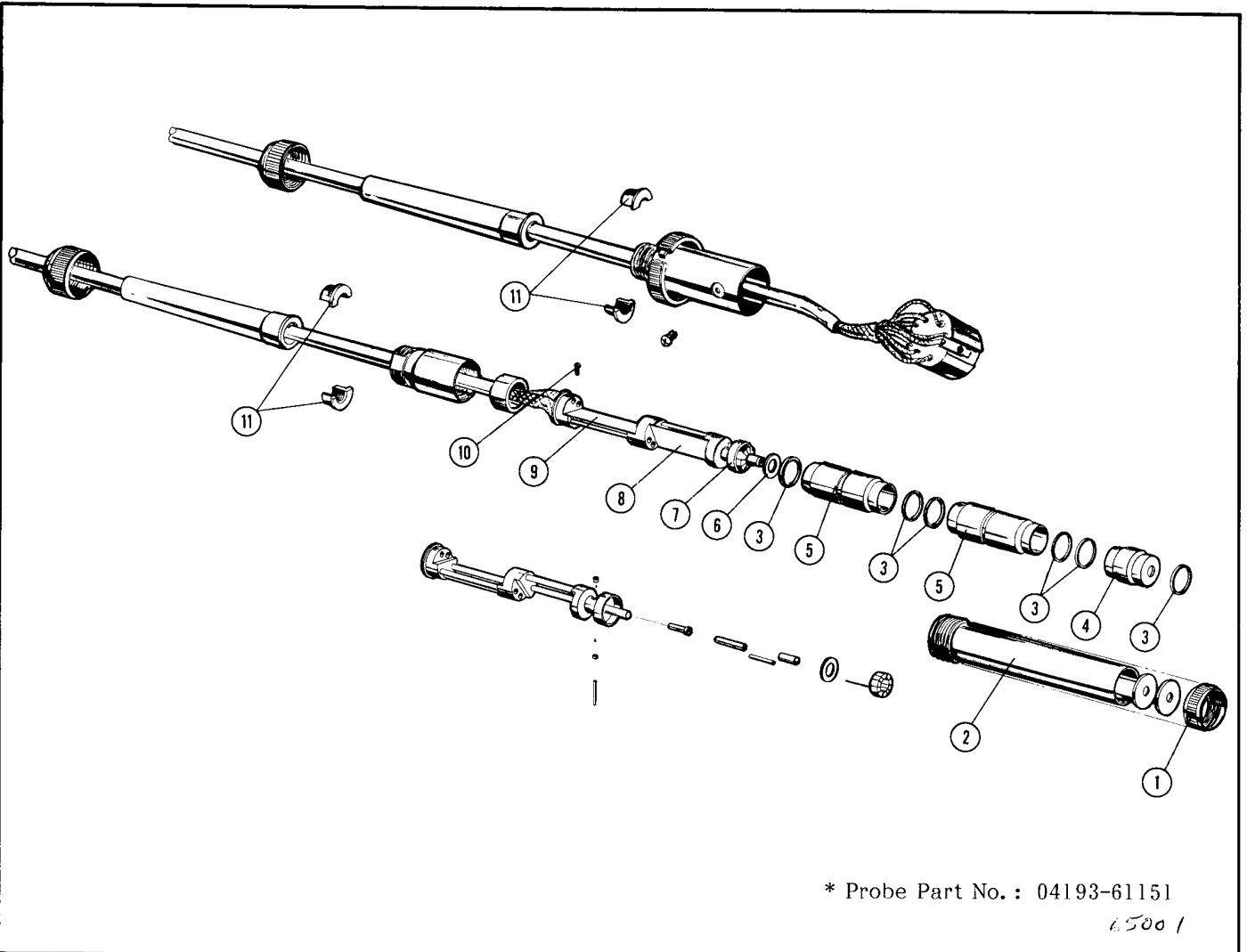

Reference	HP Part No.	Qty	Description
1	04193-24012	1	NUT
2	04193-21018	1	PROBE HOUSING
3	04193-21016	6	RING
4	04193-21014	1	INNER SHELL (TOP)
5	04193-21015	2	INNER SHELL
6	3050-1080	1	WASHER
7	04193-61551	1	CURRENT TRANSFORMER
8	04193-66551	1	A51 BOARD ASS'Y
9	04193-66552	1	A52 BOARD ASS'Y
10	0516-0003	4	SCREW
11	04193-40012	4	CABLE COLLAR

Figure 6-1. Exploded View of Probe Assembly.

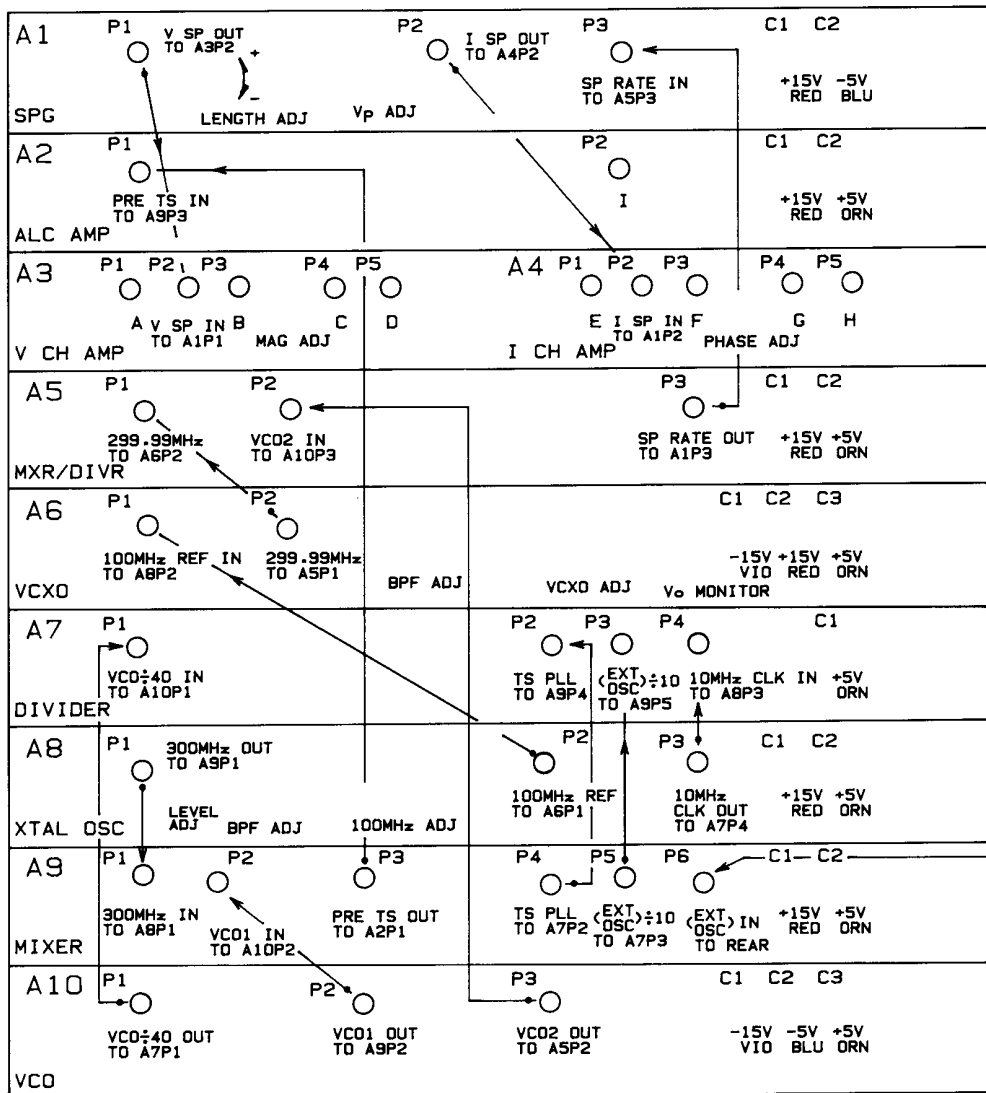

Figure 6-2. Top View of Extrusion Boards.

Table 6-5. Cables on Extrusion Boards.

Terminals	Cable Part No.	Cable Length	Color	
			Cable	Heat shrink
A1P1 — A3P2	04193-61631	380 mm	blue	black
A1P2 — A4P2*	04193-61615	100 mm	yellow	red
	04193-61616	150 mm		yellow
	04193-61617	200 mm		blue
A1P3 — A5P3	04193-61619	180 mm	blue	yellow
A2P1 — A9P3	04193-61620	220 mm	blue	blue
A2P2 — Probe (I)	———— 61614	————	blue	blue
A3P1 — Probe (A)	———— 61613	————	blue	blue
A3P3 — Probe (B)	———— 61612	————	blue	blue
A3P4 — Probe (C)	———— 61611	————	blue	blue
A3P5 — Probe (D)	———— 61610	————	blue	blue
A4P1 — Probe (E)	———— 61609	————	blue	blue
A4P3 — Probe (F)	———— 61608	————	blue	blue
A4P4 — Probe (G)	———— 61607	————	blue	blue
A4P5 — Probe (H)	———— 61606	————	blue	blue
A5P1 — A6P2	04193-61618	70 mm	blue	red
A5P2 — A10P3	04193-61620	220 mm	blue	blue
A6P1 — A8P2	04193-61619	180 mm	blue	yellow
A7P1 — A10P1	04193-61619	180 mm	blue	yellow
A7P2 — A9P4	04193-61618	70 mm	blue	red
A7P3 — A9P5	04193-61618	70 mm	blue	red
A7P4 — A8P3	04193-61618	70 mm	blue	red
A8P1 — A9P1	04193-61618	70 mm	blue	red
A9P2 — A10P2	04193-61618	70 mm	blue	red
A9P6 — EXT OSC	04193-61603	600 mm	blue	blue

* : cables for adjustment

A1

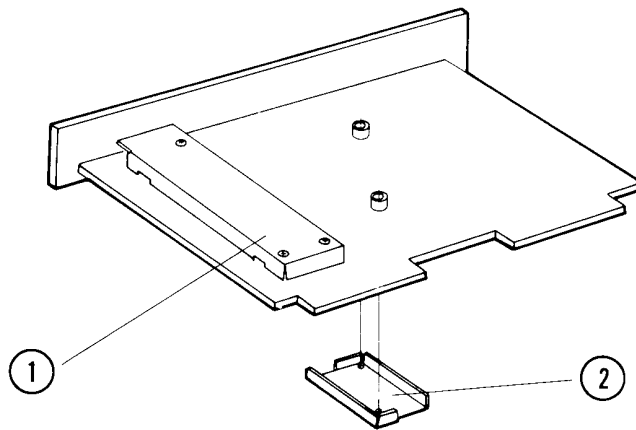

Reference	HP Part No.	Qty	Description
1	04193-00606	1	SHIELD BOX 40x120x12.3
2	04193-00607	1	SHIELD BOX 36x55x4

A6

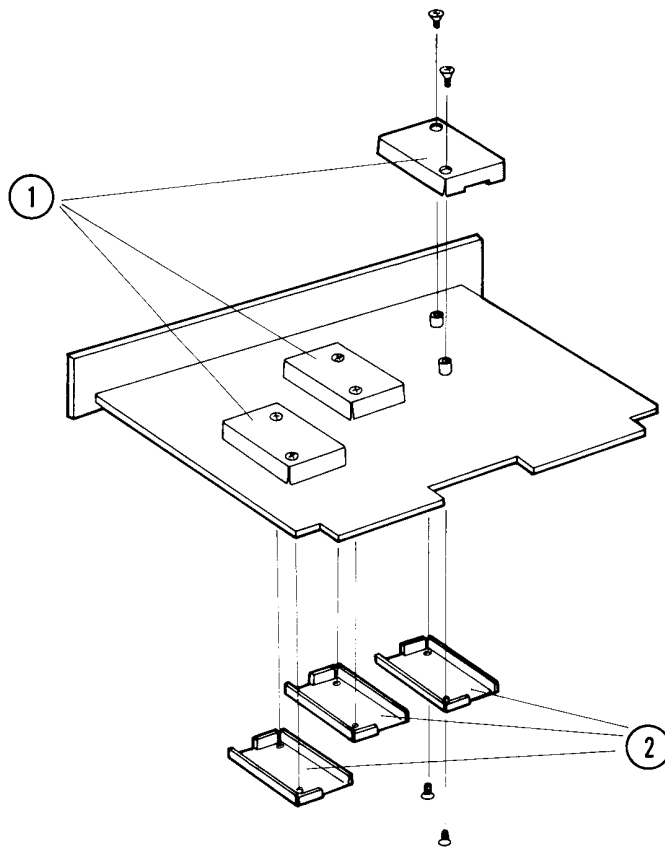

Reference	HP Part No.	Qty	Description
1	04193-00604	3	SHIELD BOX 36x55x12.3
2	04193-00607	3	SHIELD BOX 36x55x4

Figure 6-3. Shield Box (Sheet 1 of 3).

A8

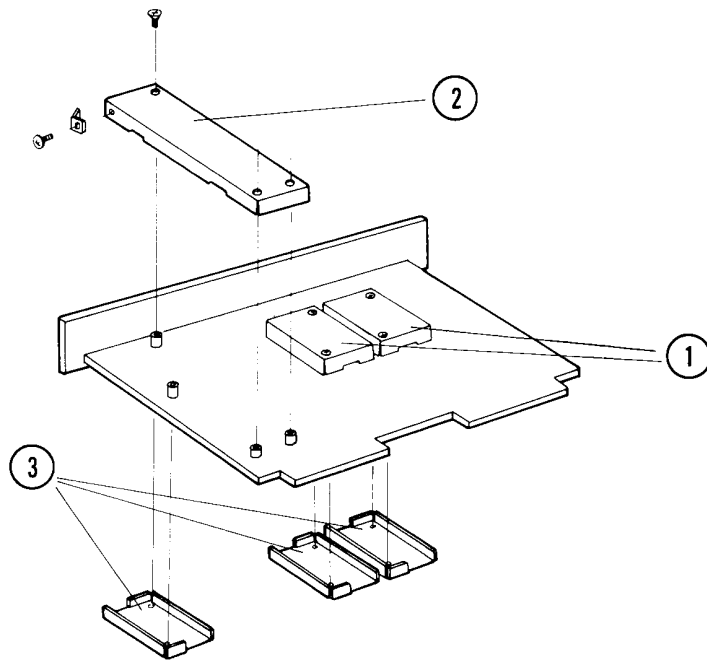

Reference	HP Part No.	Qty	Description
1	04193-00604	2	SHIELD BOX 36x55x12.3
2	04193-00606	1	SHIELD BOX 40x120x12.3
3	04193-00607	3	SHIELD BOX 36x55x4

A9

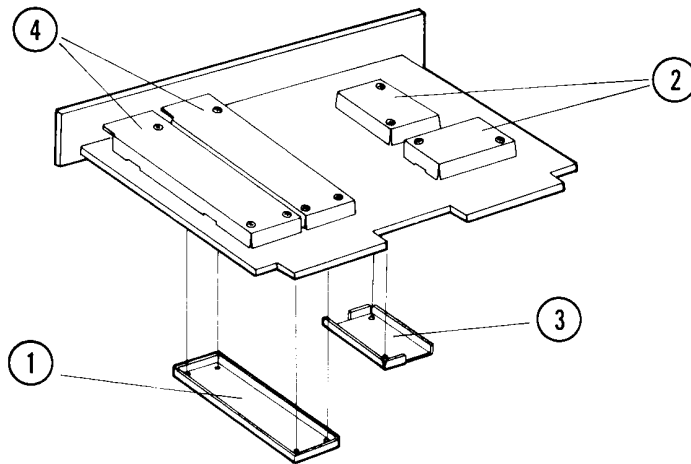

Reference	HP Part No.	Qty	Description
1	04191-00614	1	SHIELD BOX 36x97x4
2	04193-00604	2	SHIELD BOX 36x55x12.3
3	04193-00607	1	SHIELD BOX 36x55x4
4	04193-00608	2	SHIELD BOX 36x110.5x12.3

Figure 6-3. Shield Box (Sheet 2 of 3).

A10

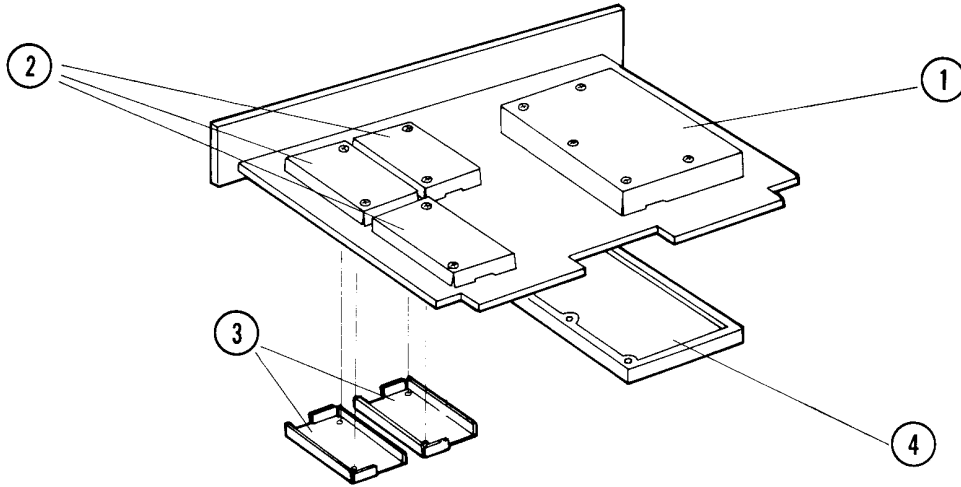

Reference	HP Part No.	Qty	Description
1	04191-00601	1	SHIELD BOX 56x91x12.3
2	04193-00604	3	SHIELD BOX 36x55x12.3
3	04193-00607	2	SHIELD BOX 36x55x4
4	04193-20006	1	SHIELD BOX 46.5x91x4

Figure 6-3. Shield Box (Sheet 3 of 3).

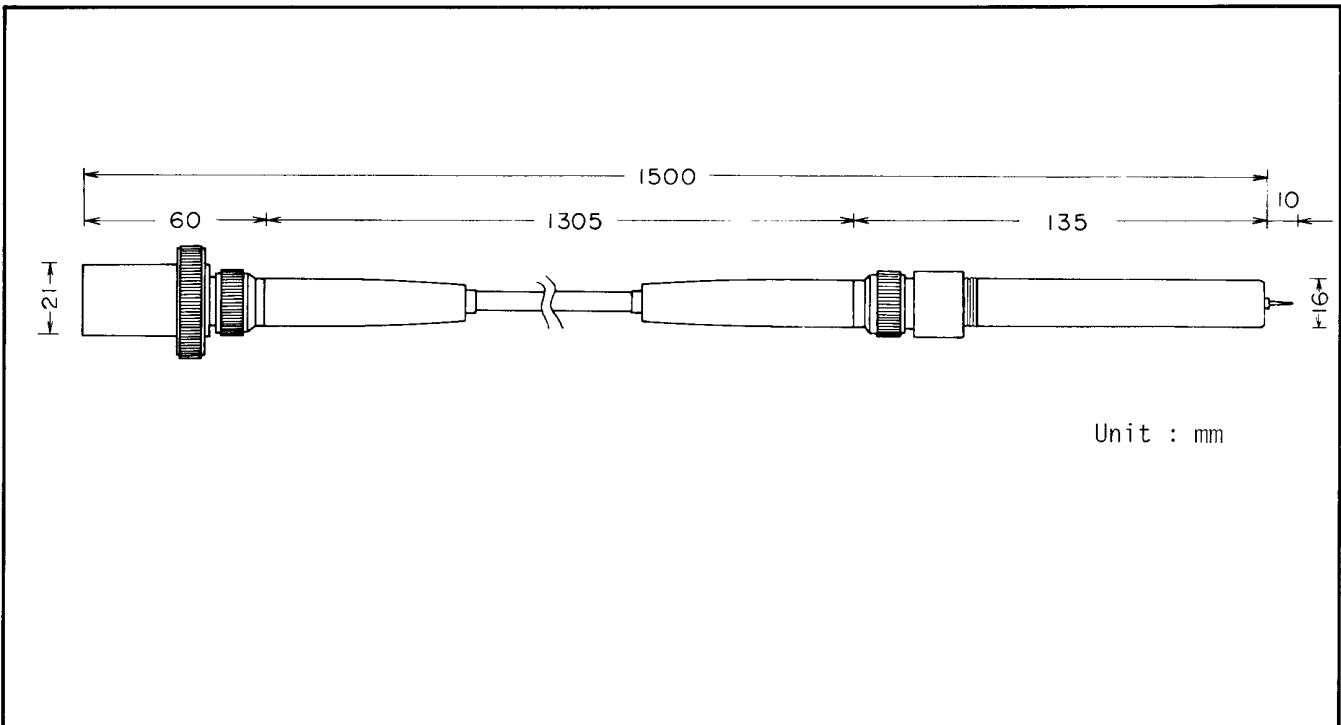

Figure 6-4. Probe Dimensions.

SECTION VII MANUAL CHANGES

7-1. INTRODUCTION

7-2. This section contains information for adapting this manual to instruments to which the contents do not directly apply. The following paragraphs explain how to adapt this manual to apply to older instruments with a lower serial prefix.

7-3. MANUAL CHANGES

7-4. To adapt this manual to your particular instrument, refer to Table 7-1 and make all of the manual changes listed opposite your instrument serial number. Perform these changes in the summary by assembly.

7-5. If your instrument serial number is not listed on the title page of this manual or in Table 7-1 to the right, it may be documented in a yellow MANUAL CHANGES supplement. For additional information about serial number coverage, refer to INSTRUMENT COVERED BY MANUAL in Section I.

Table 7-1. Manual Changes by Serial Number

Serial Prefix or Number	Make Manual Changes
2136J00106 and below	1
2136J00124 and below	2
2022J00144 and below	3
2022J00264 and below	4

SECTION VII

CHANGE 1

Page 3-6, Figure 3-2 :
Partially change the figure as follows :

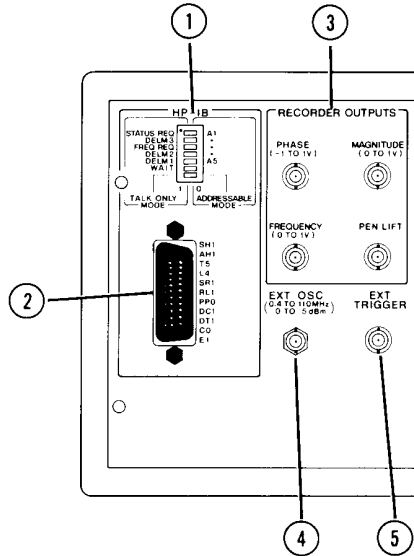

Page 3-20, para. 3-62, line 4 :
Change the line as follows :

logical 0 (right position) and logical 1 (left)

Page 3-20, Figure 3-14 :
Change the figure as follows :

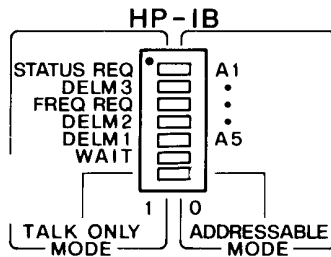

Figure 3-14. HP-IB Control Switch.

Page 3-20, Figure 3-15 :
Change the figure as follows :

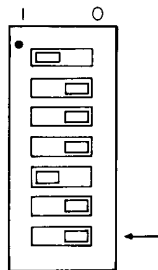

Figure 3-15. ADDRESSABLE Mode.

Page 3-21, Figure 3-16 :
Change the figure as follows :

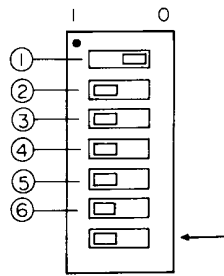
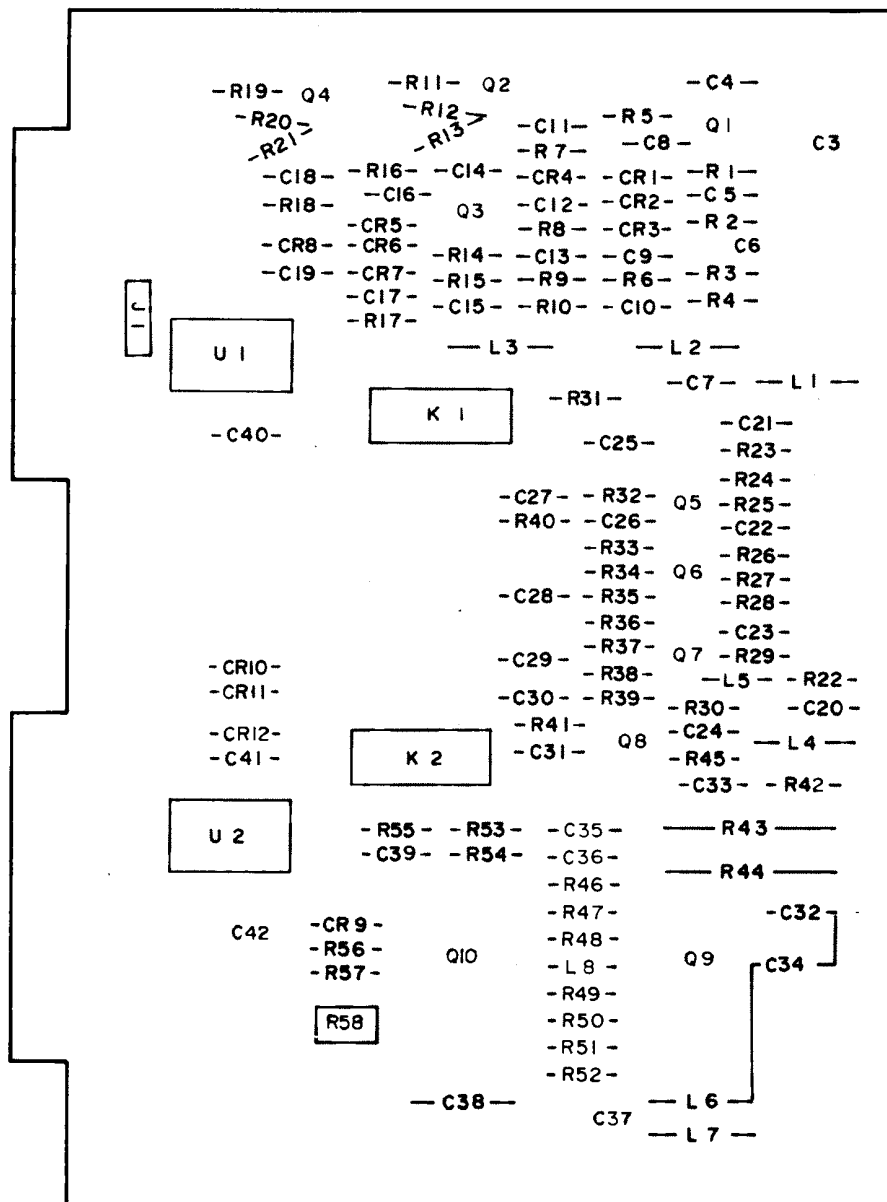

Figure 3-16. TALK ONLY Mode.

Page 8-47, Figure 8-28. A2 ALC Amplifier Board Assembly Component Locations:
Partially change the figure as follows:



SECTION VII

Page 8-47, Figure 8-29. A2 ALC Amplifier Board Assembly Schematic Diagram:
Partially change the diagram as follows:

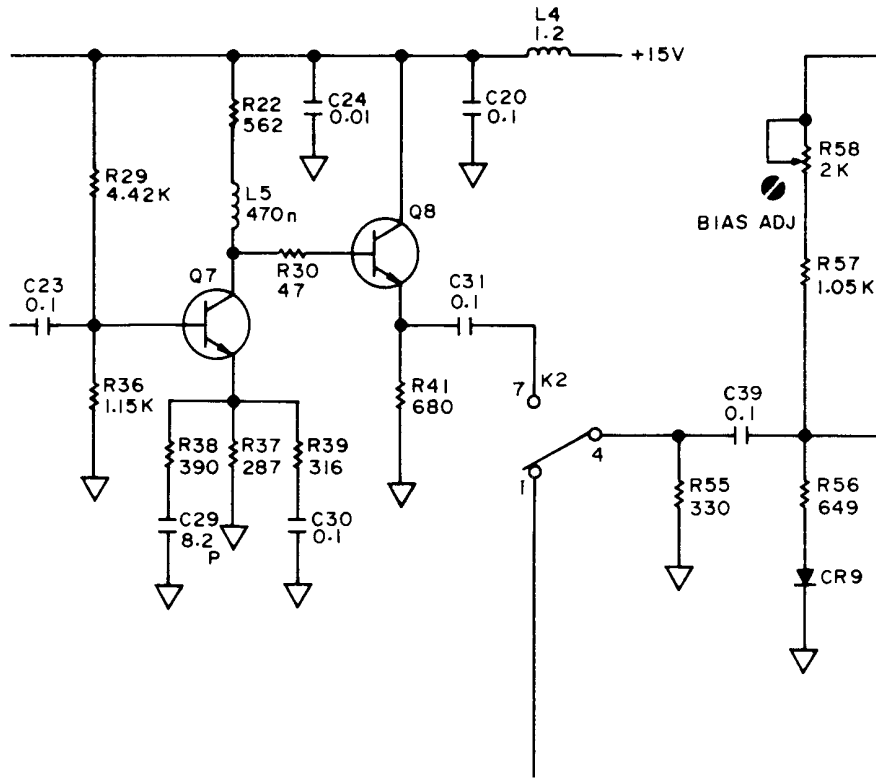

SECTION VII

Page 8-131, Figure 8-76. A20 Power Supply Board Assembly Schematic Diagram:
Partially change the diagram as follows:

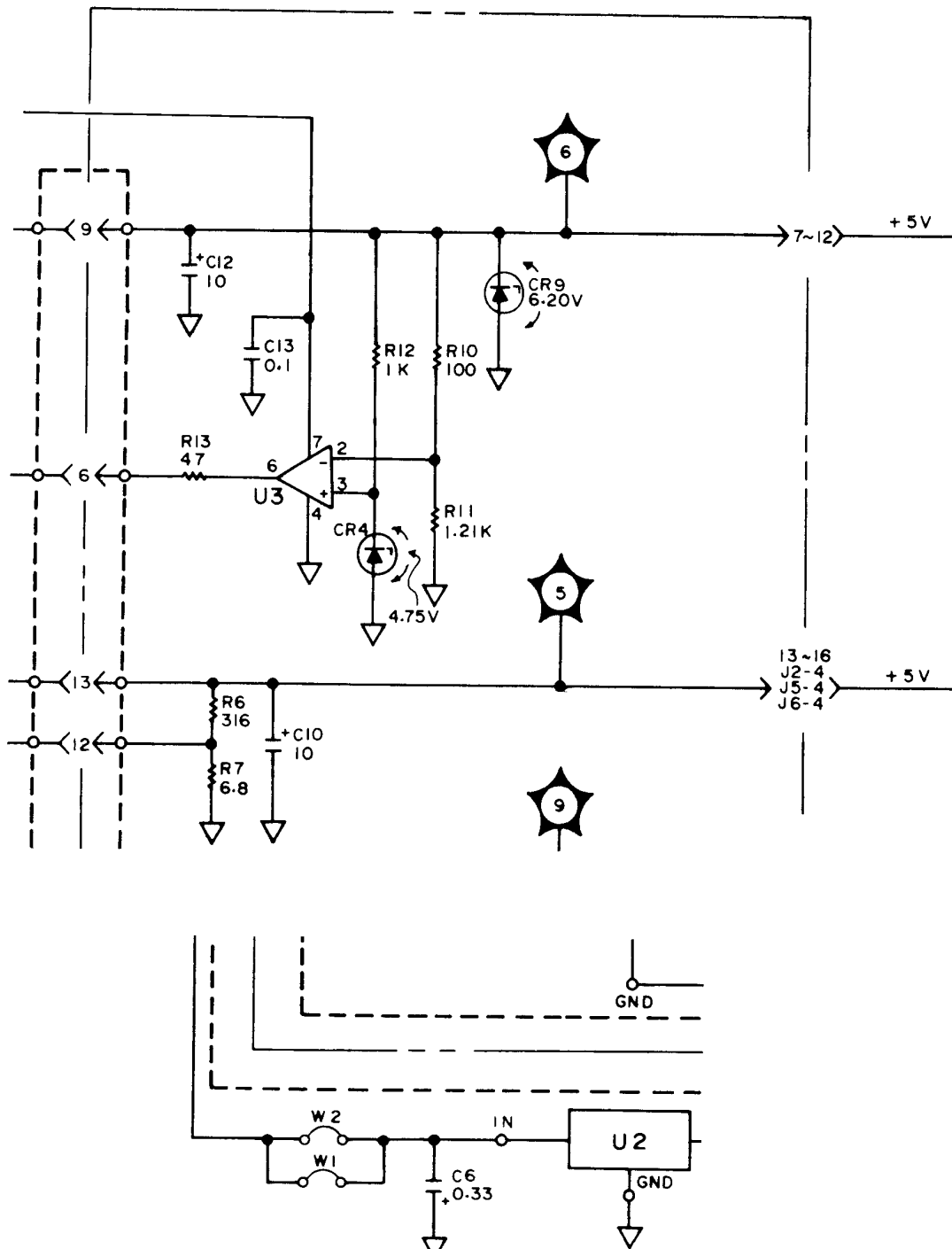
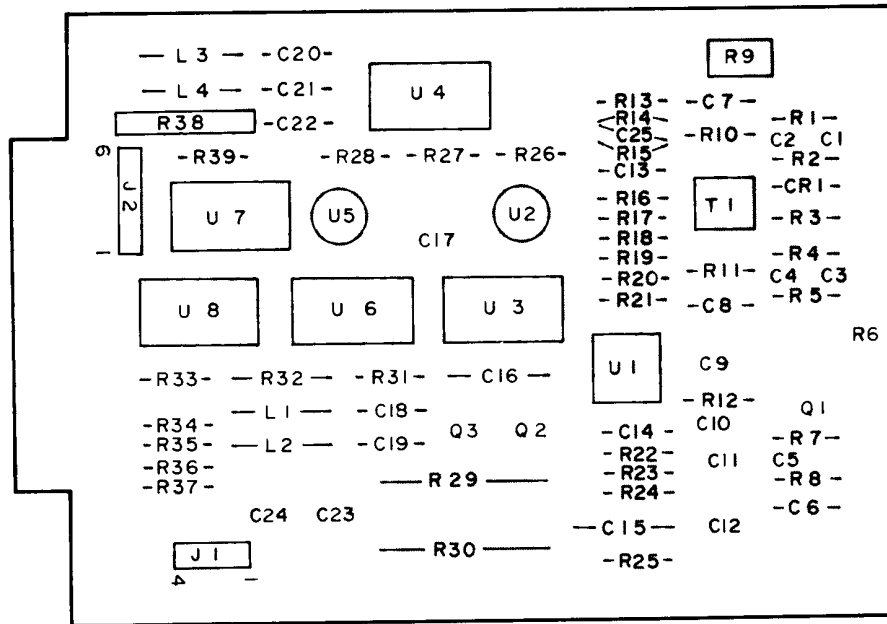

Table 6-3. Replaceable Parts:
See Table 7-2.

CHANGE 2

Page 8-53, Figure 8-31. V-Channel Amplifier Board Assembly Component Locations:
Partially change the diagram as follows:



Page 8-53, Figure 8-33. V-Channel Amplifier/A52 Probe V-Channel Board Assembly Schematic Diagram:
Delete A3R40.

Page 8-59, Figure 8-37. A4 I-Channel Amplifier/A51 Probe I-Channel Board Assembly Schematic Diagram:
Partially change the diagram as follows:

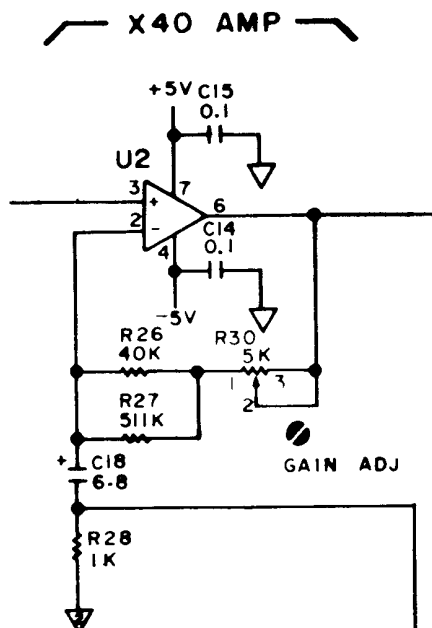
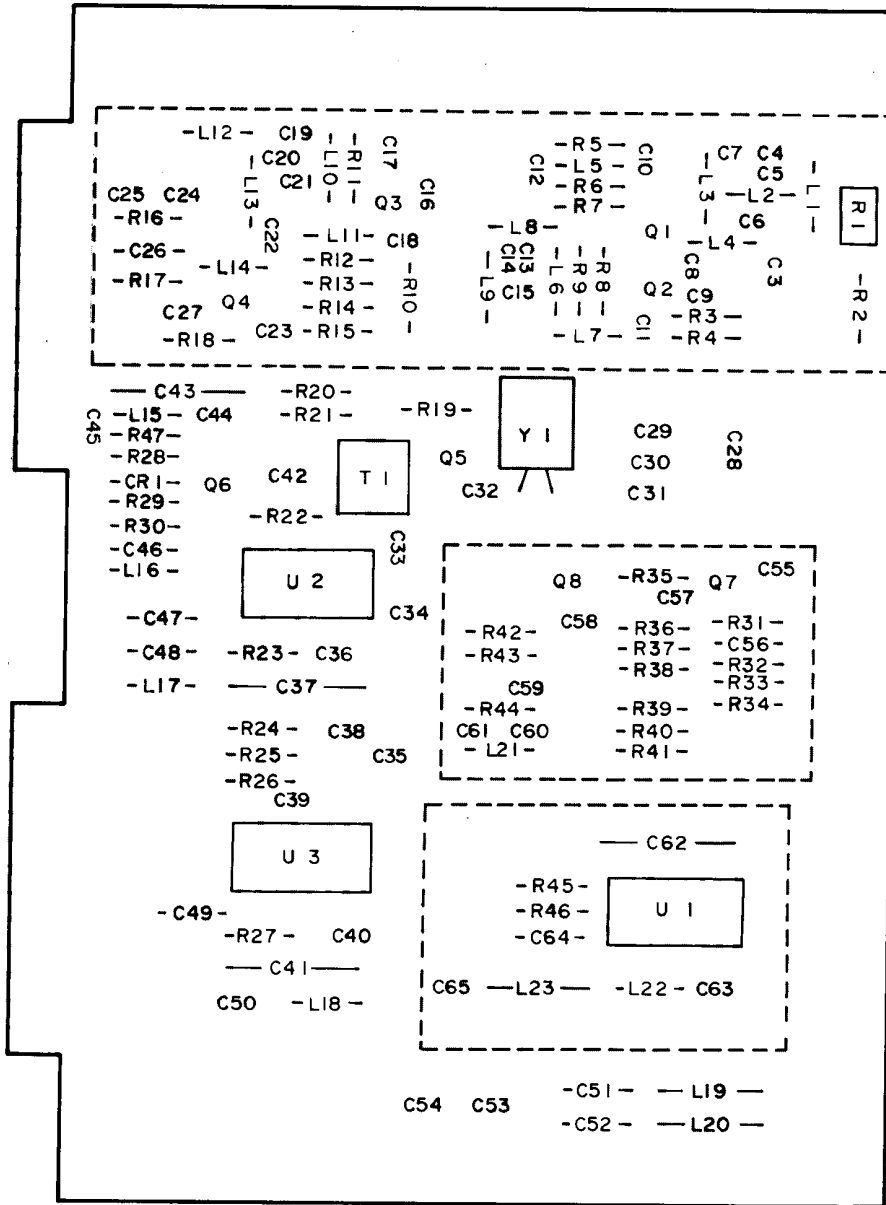

Table 6-3. Replaceable Parts:
See Table 7-2.

SECTION VII

CHANGE 3

Page 8-77, Figure 8-46. A8 Crystal Oscillator Board Assembly Component Locations:
Partially change the diagram as follows:



Page 8-77, Figure 8-47. A8 Crystal Oscillator Board Assembly Schematic Diagram:
Partially change the diagram as follows:

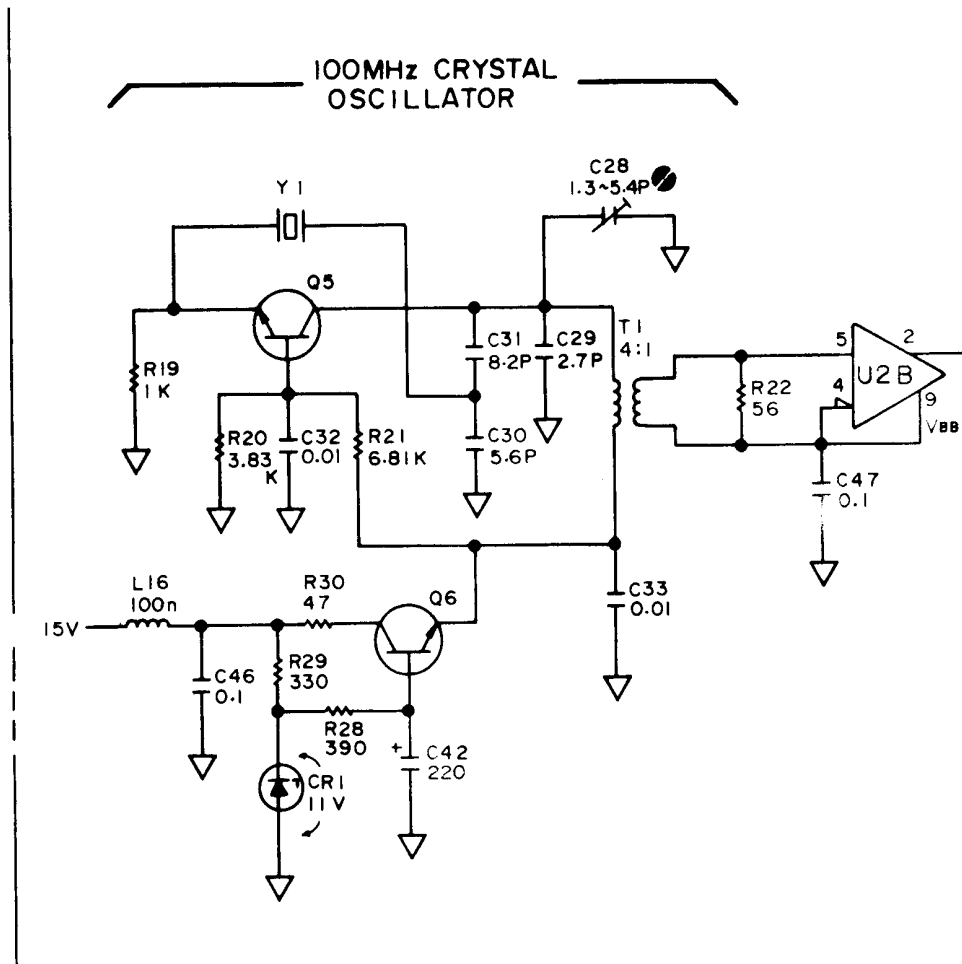

SECTION VII

Page 8-85, Figure 8-50. A10 Voltage Controlled Oscillator Board Assembly
Component Locations:

Partially change the diagram as follows:

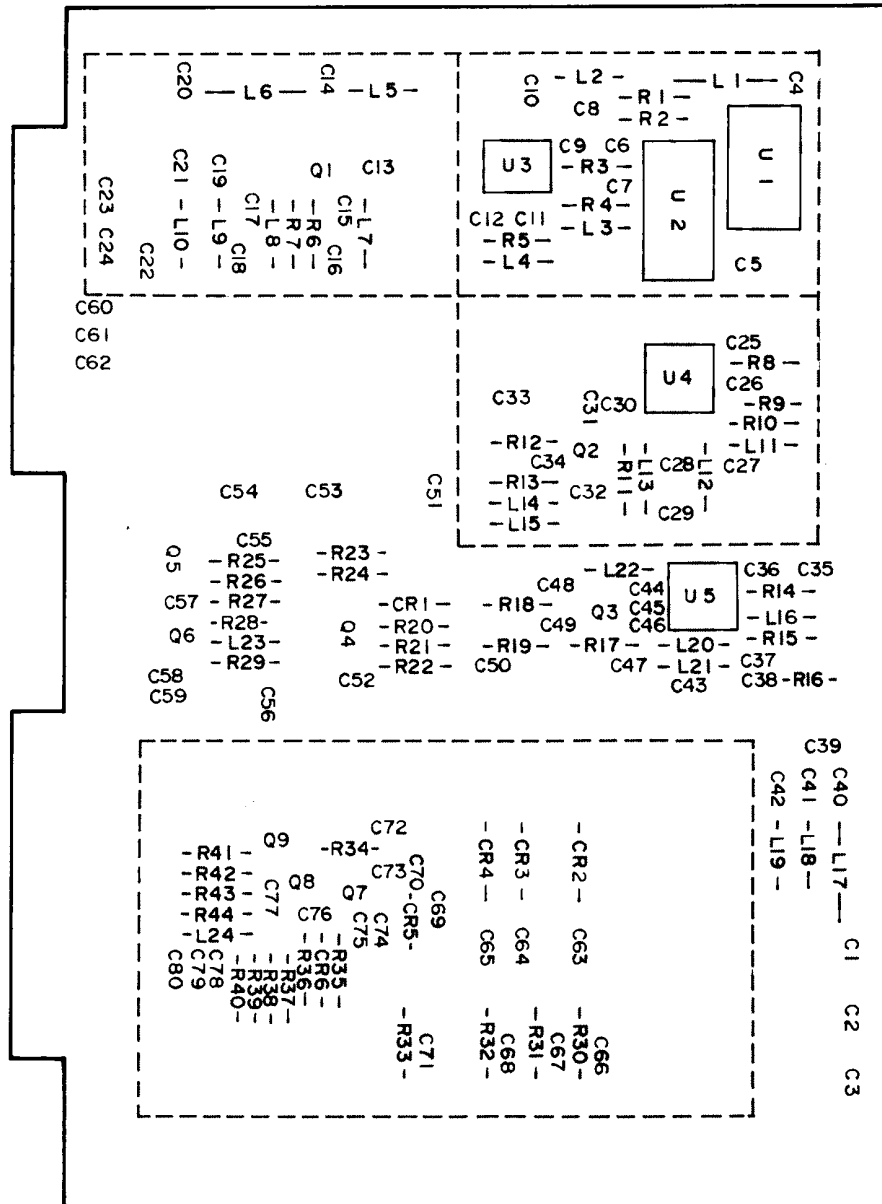
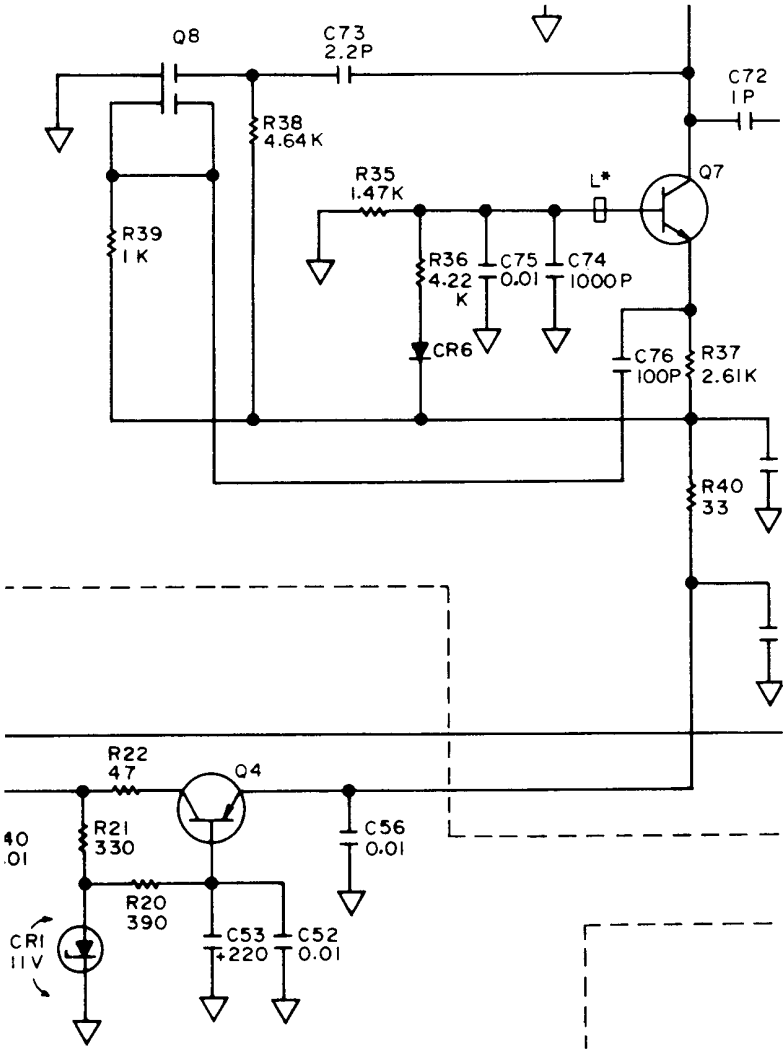

Table 6-3. Replaceable Parts:
See Table 7-2.

Page 8-85, Figure 8-51. A10 Voltage Controlled Oscillator Board Assembly Schematic Diagram:

Partially change the diagram as follows:



Page 8-131, Figure 8-75. A20 Power Supply Board Assembly Component Locations: Delete A20R27.

Page 8-131, Figure 8-76. A20 Power Supply Board Assembly Component Locations: Delete A20R27.

SECTION VII

CHANGE 4

Page 8-41, Figure 8-25. A1 Sampling Pulse Generator Board Assembly Component Locations:

Partially change the diagram as follows:

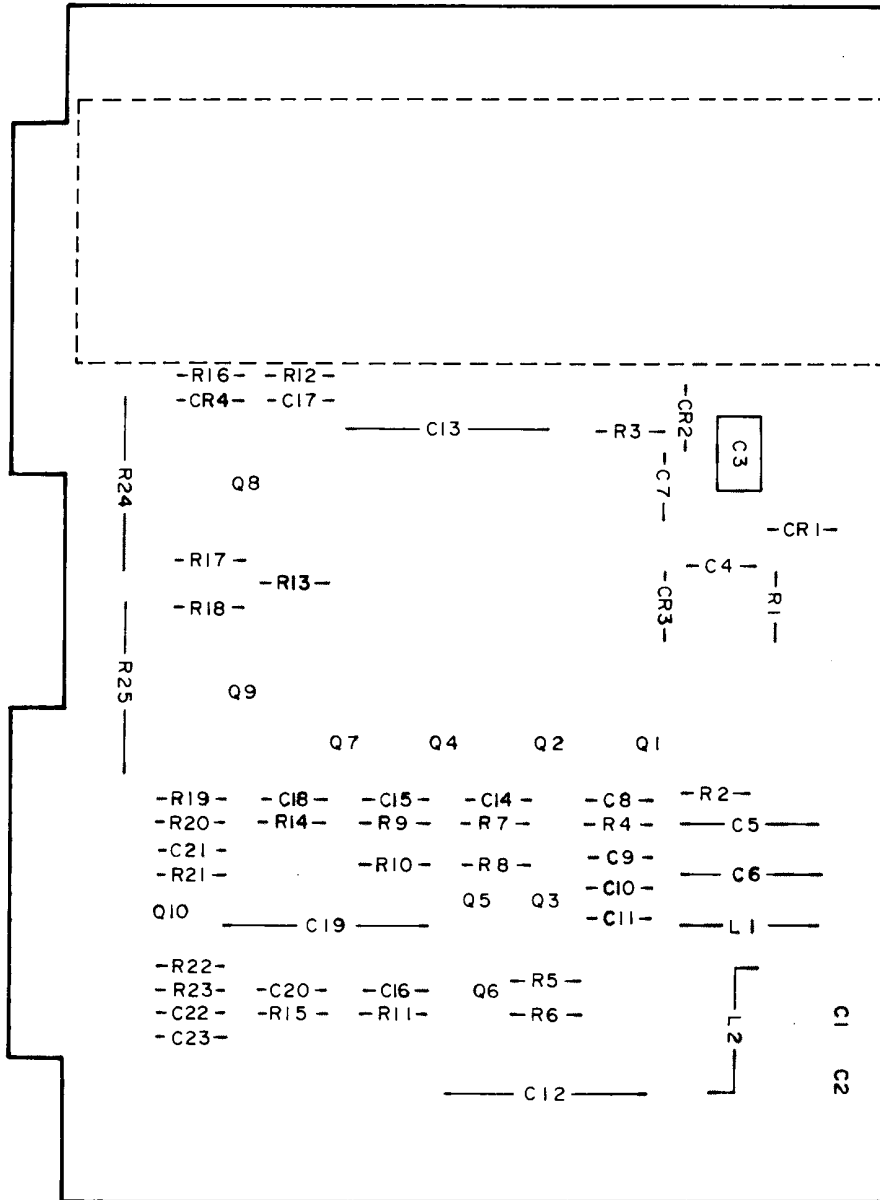

SECTION VII

Page 8-131, Figure 8-75. A20 Power Supply Board Assembly Component Locations:
Partially change the diagram as follows:

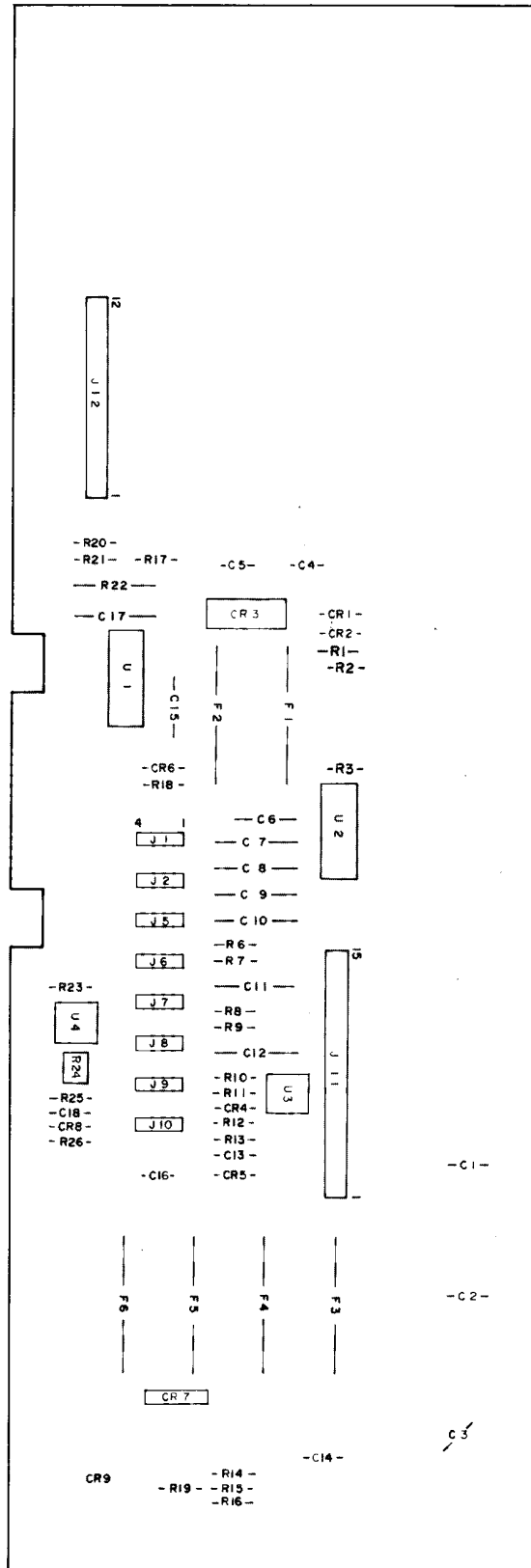

Page 8-131, Figure 8-76. A20 Power Supply Board Assembly Schematic Diagram :
Partially change the diagram as follows:

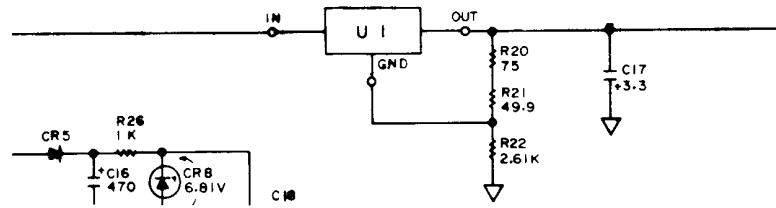
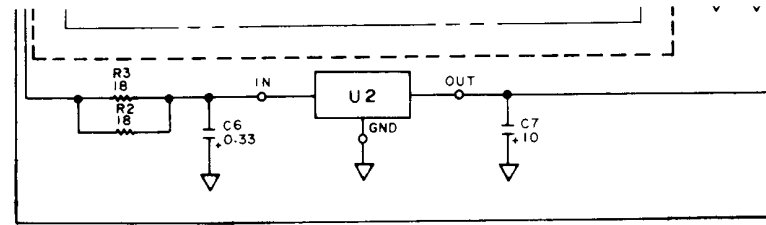

SECTION VII

Table 7-2

Change	Page	Note	Reference Designation	HP Part Number	Description
1	6-5	C	A2C29	0160-4792	CAPACITOR-FXD 8.2PF +/- .5pF 100VDC CER
		A	A2L5	9100-2255	INDUCTOR 470NH 10%
	6-6	C	A2Q8	1854-0345	TRANSISTOR NPN 2N5179 SI TO-72
		C	A2R38	0683-3915	RESISTOR 390 5% .25W
		C	A2R41	0683-6815	RESISTOR 680 5% .25W
		D	A2W1	8159-0005	JUMPER
	6-7	C	A3R1	0683-4725	RESISTOR 4.7K 5% .25W
		C	A3R5	0683-4725	RESISTOR 4.7K 5% .25W
	6-18	C	A8R12	0757-0816	RESISTOR 681 1% .5W
	6-26	A	A11S1	3101-4341	SWITCH SLIDE SPDT-NG
	6-39	D	A20R2	0698-7457	RESISTOR 18 2% 2W
		D	A20R3	0698-7457	RESISTOR 18 2% 2W
	6-40	A	A20W1	8159-0005	JUMPER WIRE
A		A20W2	8159-0005	JUMPER WIRR	
6-42	C	54	04193-66600	HP-IB CONNECTOR	
2	6-7	C	A3R2	0683-5105	RESISTOR 51 5% .25W
		C	A3R4	0683-5105	RESISTOR 51 5% .25W
		C	A3R23	0699-0057	RESISTOR 9K .1% .1W
	6-8	D	A3R40*	0757-0464	RESISTOR 90.9K 1%
	6-9	C	A4R1	0683-4275	RESISTOR 4.7K 5% .25W
		C	A4R2	0683-5105	RESISTOR 51 5% .25W
		C	A4R4	0683-5105	RESISTOR 51 5% .25W
		C	A4R5	0683-4275	RESISTOR 4.7K 5% .25W
		C	A4R27	No change	No change
	3	6-39	C	A20R26	0683-1025
D			A20R27	0683-1825	RESISTOR 1.8K 5% .25W
4	6-4	D	A1R26	2100-3212	RESISTOR
		C	A1R27	0757-0442	RESISTOR
	6-17	C	A6C29	0160-2243	CAPACITOR-FXD 2.7PF +/- .25PF 500VDC CER
		C	A6C30	0160-2255	CAPACITOR-FXD 8.2PF +/- .25PF 500VDC CER
		C	A6C31	0160-2251	CAPACITOR-FXD 5.6PF +/- .25PF 500VDC CER
	6-39	D	A20C19	0180-0291	CAPACITOR-FXD 1UF 35VDC TA
		D	A20C20	0180-0291	CAPACITOR-FXD 1UF 35VDC TA
	6-40	D	A20U5	1826-0106	IC V RGLTR 7815
		D	A20W3	8159-0005	JUMPER WIRE

A: Added D: Changed D: Deleted

SECTION VIII

SERVICE

8-1. INTRODUCTION

8-2. This section provides the information and instructions required to service the Model 4193A Vector Impedance Meter. Included are the Theory of Operation and Circuit Schematics. The Theory of Operation describes fundamental principles and circuit operating theory of the 4193A with block diagrams. Circuit schematics, locator illustrations, board level block diagrams and other technical data necessary for repairs are integrated into the service sheet foldouts. An illustration of the instrument interior is shown in Figure 8-19.

8-3. SAFETY CONSIDERATIONS

8-4. This section contains warnings and cautions that must be followed for your protection and to avoid damage to the instrument.

WARNING

MAINTENANCE DESCRIBED HEREIN IS PERFORMED WITH POWER SUPPLIED TO THE INSTRUMENT AND PROTECTIVE COVERS REMOVED. SUCH MAINTENANCE SHOULD BE PERFORMED ONLY BY SERVICE-TRAINED PERSONNEL AWARE OF THE HAZARDS INVOLVED (FOR EXAMPLE, FIRE AND ELECTRICAL SHOCK). WHERE MAINTENANCE CAN BE PERFORMED WITHOUT POWER APPLIED, THE POWER SHOULD BE REMOVED. BEFORE ANY REPAIR IS COMPLETED, ENSURE THAT ALL SAFETY FEATURES ARE INTACT AND FUNCTIONING AND THAT ALL NECESSARY PARTS ARE CONNECTED TO THEIR MEANS OF PROTECTIVE GROUNDING.

8-5. THEORY OF OPERATION

8-6. The theory of operation discussion is organized into two sections : basic theory and block diagram discussion. The basic theory, beginning with paragraph 8-13, explains the concepts and fundamental theory of the 4193A instrument technique adapted for accurately measuring the DUT and for fully achieving automated measurement performance. The block diagram discussion describes the overall circuit operating theory of the 4193A with block-to-block signal flow. Included are block and timing diagrams.

8-7. RECOMMENDED TEST EQUIPMENT

8-8. The test equipment required to perform operations outlined in this section is listed in Table 4-1. The table includes type of instrument required, critical specifications, use, and recommended model. If the recommended model is not available, equipment which meets or exceeds the critical specifications listed may be substituted.

8-9. TROUBLESHOOTING

8-10. The troubleshooting guide provides instructions and information for locating a faulty circuit component. All instructions consider the safety of service personnel performing the procedures. The diagnostic guides are in the form flow diagrams. The board level troubleshooting diagrams are used to isolate failures to an individual malfunctioning circuit board assembly. The guides for locating a defective component are given on the individual board service sheets and integrate service support data-- test point locations, waveform illustrations, voltage data, timing diagrams, and other technical information in addition to providing schematic diagrams for each board. To facilitate troubleshooting of the 4276A Digital Section, the troubleshooting guide for the logic circuits uses signature analysis.

Note

To facilitate troubleshooting, remove all screws from the extrusion boards.

8-11. REPAIR

8-12. Repair explanations tell how to replace defective circuit components. The recommended replacement procedures for components and parts which require special repair, replacement tools, or test equipment should be observed. Correct disassembly and the exchange procedures for such special parts are outlined in paragraphs 8-81 through 8-91. To prevent damage resulting from improper repair procedure, refer to the appropriate manual section before proceeding with repair.

SECTION VIII

8-13. BASIC THEORY

8-14. The HP Model 4193A Vector Impedance Meter applies a constant test current to the DUT and measures two vector voltages, \dot{V}_I and \dot{V}_V , to obtain the DUT impedance, \dot{Z} . \dot{V}_I is the voltage drop across known resistance R_0 , and \dot{V}_V is the voltage drop across the DUT. Refer to Figure 8-1. The vector current \dot{I} through R_0 is proportional to the vector current \dot{I} through the DUT. Therefore, the vector impedance \dot{Z} of the DUT is given by the vector voltage ratio \dot{V}_V / \dot{V}_I as follows :

$$\dot{Z} = \frac{\dot{V}_V}{\dot{I}} \propto \frac{\dot{V}_V}{\dot{I}} = \frac{\dot{V}_V}{\dot{V}_I/R_0} = R_0 \cdot \frac{\dot{V}_V}{\dot{V}_I}$$

$$\therefore \dot{Z} \propto \frac{\dot{V}_V}{\dot{V}_I}$$

In the actual circuit, both the magnitude and the phase of each vector voltage are detected to calculate the magnitude ratio and the phase difference between \dot{V}_V and \dot{V}_I . The impedance and the phase of \dot{Z} are given below :

$$|\dot{Z}| = k \cdot \frac{|\dot{V}_V|}{|\dot{V}_I|} \quad (k: \text{constant})$$

$$\angle \dot{Z} = \angle \dot{V}_V - \angle \dot{V}_I$$

Figure 8-2 shows the relation between \dot{Z} , \dot{V}_V , and \dot{V}_I .

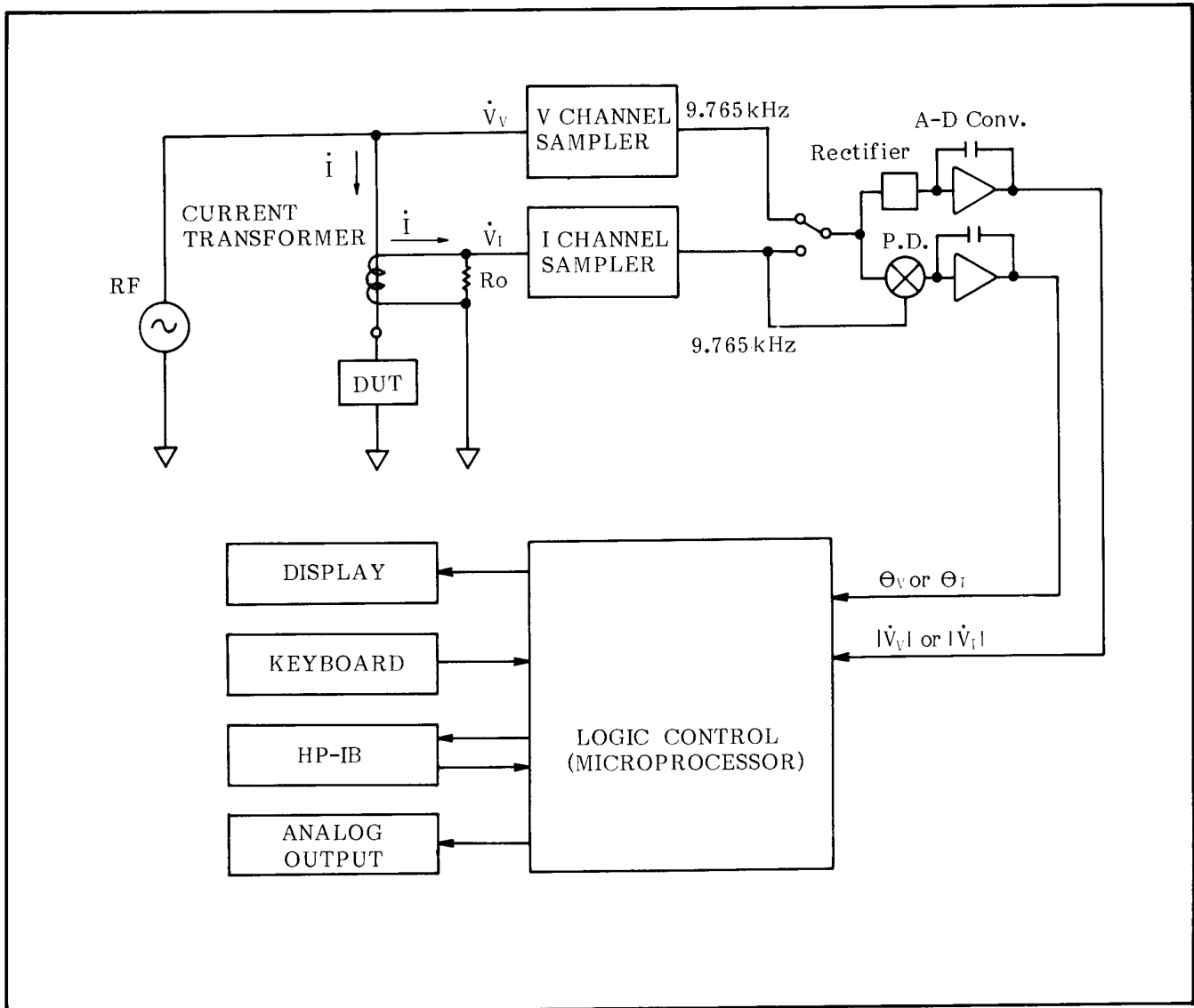

Figure 8-1. Basic Block Diagram.

The test frequency, RF, is a radio frequency between 0.4 to 110MHz. Therefore, sampling is performed in the \dot{V}_I and \dot{V}_V detecting stage to facilitate accurate detection of the vector voltage ratio. The 4193A uses a unique sampling method called synchronized mixed-down sampling pulse generation. It enables the 4193A to perform stable sampling operation to convert the RF measurement signals into two 9.765625kHz IF signals, even when the RF test frequency is changed. The relationship between the magnitudes of \dot{V}_I and \dot{V}_V and the phase differences between \dot{V}_I and \dot{V}_V remain unchanged, even after sampling.

\dot{V}_I and \dot{V}_V are alternately measured to provide magnitude and phase information. Either \dot{V}_I or \dot{V}_V is selected and channeled into two paths; one to a magnitude-ADC through a full-wave rectifier and the other to a phase-ADC through

the phase detector. The reference signal of the phase detector is \dot{V}_I and the input signal is alternately \dot{V}_V and \dot{V}_I . This means that \dot{V}_I is phase detected in reference to itself in order to provide compensation for any phase offset error introduced by the detection circuits. In each of the two ADCs, dual-slope (type) analog to digital conversion is executed 17 times per measurement for \dot{V}_V and 12 times per measurement for \dot{V}_I in normal speed mode. See Figure 8-3.

The 4193A contains a 6800 microprocessor that controls the frequencies, range selection, measurement sequence, data manipulation, and other functions. It also performs introspective testing of the 4193A.

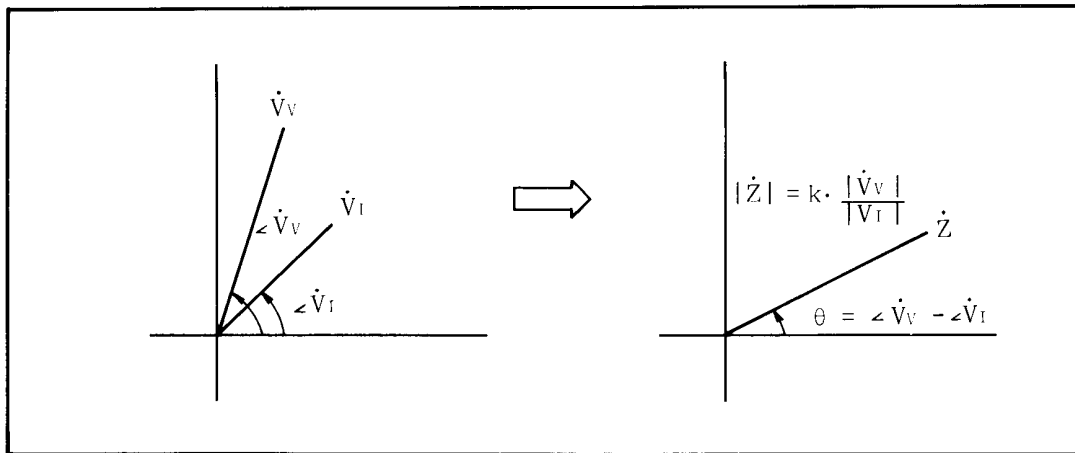

Figure 8-2. Relation between \dot{Z} , \dot{V}_V , and \dot{V}_I .

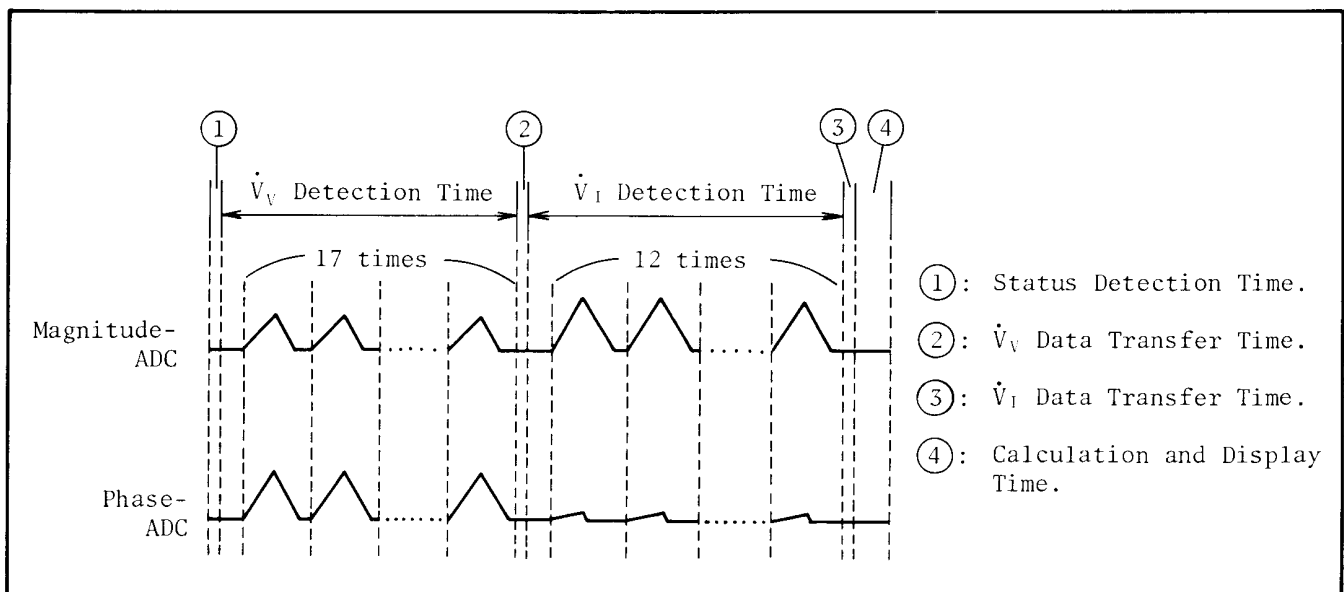

Figure 8-3. Measurement Cycle.

SECTION VIII

8-15. Analog Section Block Diagram Discussion

8-16. The following paragraphs describe the structure and functions of the 4193A's Analog Section. The Analog Section consists of the Signal Source, Sampling Block, and Detection Block. The block diagram of the Analog Section is shown in Figure 8-10.

8-17. SIGNAL SOURCE BLOCK

8-18. Figure 8-4 is the block diagram of the Signal Source, consisting of the A8 Crystal Oscillator, A10 Voltage Controlled Oscillator, A9 Mixer, A2 ALC Amplifier, A7 Divider, and A11 Integrator. The A8 Crystal Oscillator generates an accurate 100MHz signal which is used as the reference on the A6 board. The A8 board also outputs a 10MHz signal to the A7 Divider and a 300MHz signal to the A9 Mixer. The A10 Voltage Controlled Oscillator outputs a 300MHz+RF signal to the A9 Mixer and the A5 Mixer/Divider. The VCO on the A10 board is controlled by the A11 Integrator, which phase-detects a reference signal from the A7 board and the RF test signal fed back from the A9 board. The A7 Divider has several functions. It divides down the RF test signal fed back from the A9 board for phase-detection on the A11 board, provides the reference signal for the phase-detector on the A11 board, provides PLL control, and provides a 2MHz clock signal and a 2.5MHz clock signal for various operations throughout the instrument. The A9 Mixer mixes the 300MHz+RF signal from the A10 board with the 300MHz signal from the A8 board to provide the RF test signal. The A2 ALC Amplifier provides ranging and level control of the RF signal in order to maintain a constant RF current through the DUT.

8-19. A2 ALC AMPLIFIER

8-20. A2 board maintains the test signal current constant for each magnitude range. The PIN diode attenuator is controlled by the ALC voltage fed from the A13 board and attenuates the RF test signal to a level appropriate for input to the amplifier stage. Depending on the magnitude range, the amplifier stage provides 10dB or 40dB amplification of the attenuated signal. When the magnitude range is 1k Ω , 10k Ω , or 100k Ω , the RF test signal is fed to a 30dB amplifier through two relays and then amplified by a 10dB output amplifier. For the lower magnitude ranges, the 30dB amplifier is bypassed and only the 10dB output amplifier is used. The two relays that feed the RF signal to the 30dB amplifier are controlled by the A17 board.

8-21. A7 DIVIDER

8-22. The A7 board divides down the RF signal fed back from the A9 Mixer to provide a 1kHz, 10kHz, or 100kHz signal, FV, for the phase detector on the A11 board. The N divisor is controlled by the microprocessor and is selected so that FV will be 1kHz when the RF is less than 10MHz, 10kHz when the RF is 10MHz to 99.99MHz, and 100kHz when the RF is 100MHz or higher. A second signal, FR, which is used as the reference for the phase detector on the A11 board, is generated from the 10MHz signal from the A8 board or from an external oscillator. Like FV, FR is 1kHz, 10kHz, or 100kHz depending on the RF frequency. To shorten the time required for the PLL to settle in response to large test frequency changes, two signals, \overline{FU} and \overline{FD} , are provided. \overline{FU} also prevents the 300MHz+RF signal from dropping below 300.4MHz. The A7 board also provides a 2MHz clock signal for the A17 board and a 2.5MHz clock signal for the A14 board, signal source ready signal (SSRDY), and external oscillator monitor signal (EXTOSC).

8-23. A8 CRYSTAL OSCILLATOR

8-24. The A8 board provides 10MHz, 100MHz, and 300MHz outputs which are used as reference signals in various mixing and phase-detection operations in the Signal Source and Sampling Circuit. All three signals are generated from the same 100MHz crystal oscillator. The 300MHz signal is derived from the third harmonic of the 100MHz signal. The 10MHz signal is produced by dividing down the 100MHz signal.

8-25. A9 MIXER

8-26. The A9 board has three functions : (1) mix the 300MHz+RF from the A10 board with the 300MHz reference from the A8 board to provide the RF signal for the A2 board, (2) feedback the RF signal to the A7 board, and (3) divide down the external oscillator signal (if present) before it is output to the A7 board.

8-27. A10 Voltage Controlled Oscillator

8-28. The A10 board outputs a 300MHz+RF signal generated from a voltage-controlled oscillator. Control voltage for the oscillator is fed from the integrator on the A11 board. There are three frequency ranges : 300.4MHz to 309.999MHz, 310MHz to 399.99MHz, and 400MHz to 410MHz. The frequency range is determined by the FS1, FS2, and FS3 frequency select lines (from the A11 board), which are the result of decoding the 2-bit frequency range data from the A17 board.

8-29. All INTEGRATOR

8-30. The All board provides two control signals, VCS and frequency range select (FS1, FS2, FS3), for the voltage-controlled oscillator on the A10 board. VCS is the control voltage for the VCO, and is produced by a phase-detector and an integrator in response to differences between the phase-detector's reference signal, FR, and input signal, FV. The reference, FR, is 1kHz, 10kHz, or 100kHz depending on the frequency range, and is derived from the 10MHz signal output from the A8 board to the A7 board, where it is divided down to the appropriate frequency. The phase-detector's input signal, FV, is also 1kHz, 10kHz, or 100kHz depending on the frequency range, and is derived from the RF signal fed back from the A2 board to the A7 board, where it is divided down to the appropriate frequency. When the FREQUENCY CONTROL DIAL on the front-panel is rotated, the microprocessor detects this and changes the value of the divisor used to divide down the RF

signal on the A7 board. This causes the frequency of FV to be higher or lower (depending on which direction the dial is rotated) than that of FR. The phase-detector detects this difference and closes one of two analog switches, allowing the integrator to charge (or discharge) from a +5v (-5V) voltage source. The output voltage from the integrator is the control voltage, VCS, for the voltage-controlled oscillator on the A10 board. When a large frequency change is detected, the \overline{FU} (frequency up) or \overline{FD} (frequency down) signal goes LOW, closing two FET switches. With these switches closed, the integrator charges (discharges) more rapidly, shortening the time required to settle the signal source at the new frequency. FB0 and FB1 are sent from the A17 board and control the frequency range of the voltage-controlled oscillator on the A11 board. FB0 and FB1 are decoded into three signals—FS1, FS2, and FS3--and then output to the A11 board.

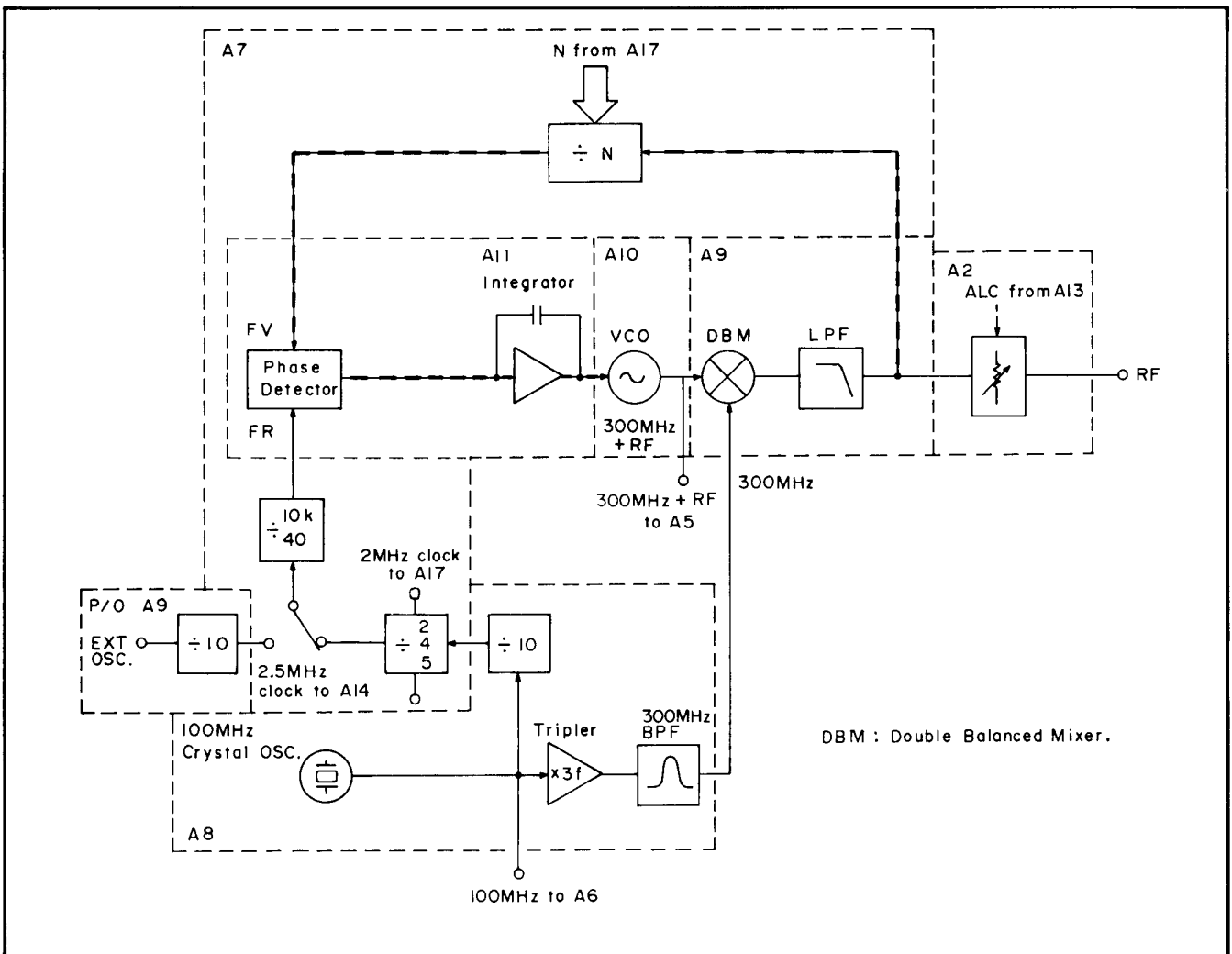

Figure 8-4. Signal Source Block Diagram.

Signal Source Operation

The frequency of the RF signal output from the 4193A's signal source is controlled by the $\div N$ circuit on the A7 board. This circuit consists of a two-modulus prescaler and four programmable counters. Refer to the block diagram in Figure A.

When the signal source is locked (NOT READY lamp off) at the frequency displayed on the front-panel, the N circuit outputs a stable 1kHz, 10kHz, or 100kHz signal, F_v , which is fed to the input of the phase detector on the A11 board. Since the phase detector's reference signal, F_R , is also 1kHz, 10kHz, or 100kHz, the phase detector outputs a constant VCO control voltage; thus, the RF signal stays at the selected test frequency. If the RF should drift, even slightly, from the selected test frequency, F_v will change, causing the phase detector to increase or decrease the VCO control voltage until the RF returns to the selected frequency. The frequency of the phase detector's reference signal, F_R depends on the range of the selected test frequency.

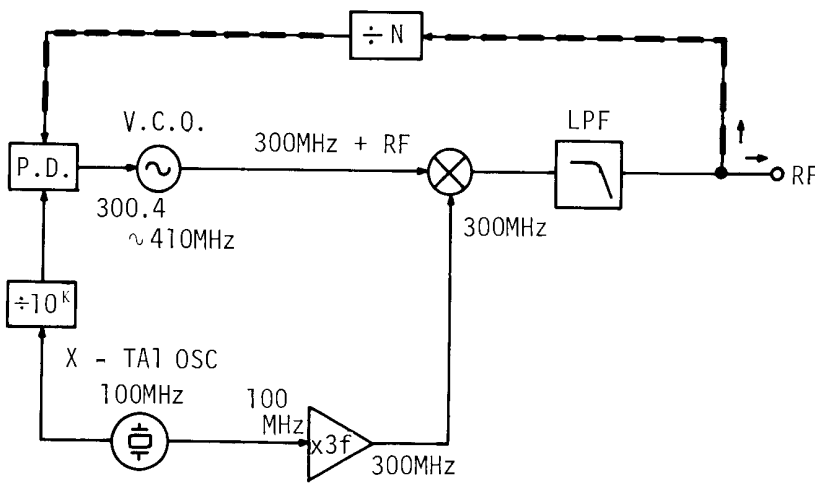

Table A. Test Freq. vs F_R

Test Freq. (MHz)	F_R
.400 to 9.999	1kHz
10.00 to 99.99	10kHz
100.0 to 110.0	100kHz

Figure A. Signal Source Simple Block Diagram.

When the FREQUENCY DIAL on the front-panel is rotated, the microprocessor changes the value of the N divisor. Consequently, F_v changes, causing the phase detector to increase or decrease the VCO control voltage until the signal source settles at the new frequency.

As an example, let's assume that the signal source is stable at a selected test frequency of 400kHz. F_R , then, is 1kHz and the N divisor must be 400 to obtain the requisite 1kHz F_v ($400k/400 = 1k$). Now, if the test frequency is changed to, say, 40kHz by rotating the FREQUENCY DIAL, the microprocessor will change the N divisor to 401. Since the test signal at this time is still 400kHz, F_v will be $400kHz/401$, or 997.51Hz. There is now a difference of 2.49Hz between F_v and F_R . The phase detector detects this difference and adjusts the VCO control voltage until the test signal is 40kHz, at which time F_v will return to 1kHz ($40k/401 = 1k$).

Figure 8-5. Signal Source Operation (Sheet 1 of 2).

÷ N Circuit

The ÷N circuit (see Figure B) functions as a programmable 4x4-bit BCD decade up-counter. The count starts at the value of N and continues until the maximum count of the counter, 9999, is reached, at which time one count cycle is completed and one pulse is output. N is the four-digit 9's complement of the number of counts on the FREQUENCY display. For example, if the test frequency is set to 400kHz, the number of counts on the FREQUENCY display is 400. The four-digit 9's complement of this number is calculated as

$$9999 - 400 = 9599 \begin{array}{l} \text{--- D} \\ \text{--- C} \\ \text{--- B} \\ \text{--- A} \end{array}$$

Some frequencies, 1MHz, 10MHz, and 100MHz, for example, have the same N divisors. This means that FV will be 1kHz, 10kHz, and 100kHz, respectively, as will FR (see Table A). This is true for all test frequencies that have the same number of display counts.

Two-Modulus Prescaler

The prescaler in the ÷N circuit operates in one of two modes, ÷10 or ÷11, depending on the state of the Scaler Control Line. When the line is HIGH, the prescaler operates in the ÷10 mode; and when the line is LOW, in the ÷11 mode. Initially, the Scaler Control Line is LOW, setting the prescaler to the ÷11 mode and enabling the D counter. When the D counter reaches maximum count, 9, the Scaler Control Line goes HIGH, setting the prescaler to the ÷10 mode and disabling (stopping) the D counter. The content of the ABC counter at this time is $100A + 10B + C - D$. The total number of input pulses required to output one pulse from the ÷N circuit is calculated as

$$9999 - (11D + 10(100A + 10B + C - D)) = 9999 - 1000A - 100A - 10C - D$$

where A, B, and C are the three most significant digits of the N divisor and D is the least significant digit.

At the end of one cycle the output pulse is fed back to the counters and the prescaler to reset the entire circuit.

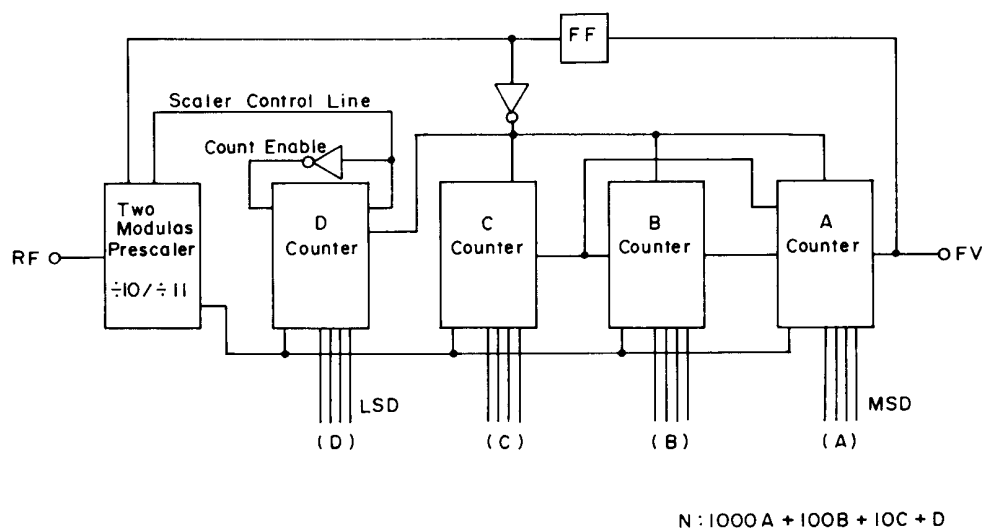

Figure B. ÷N Circuit.

SECTION VIII

8-31. SAMPLING BLOCK

8-32. The Sampling Circuit consists of the A1 Sampling Pulse Generator, A5 Mixer/Divider, A6 Voltage Controlled Oscillator, A51 Probe I-channel, and A52 Probe V-Channel. Overall Sampling Circuit operation will be discussed first, followed by simplified board level discussions.

8-33. Refer to the Sampling Circuit block diagram in Figure 8-6. Two RF signals, V_{DUT} (RF) and I_{DUT} (RF), which represent the voltage across and the current through the DUT are each converted into a 9.765625kHz IF to facilitate measurement. RF-to-IF conversion is performed in the A51 Probe I-Channel and the A52 Probe V-Channel by sampling the injected RF signal at different points of the waveform. This produces two waveforms, V_{DUT} (IF) and I_{DUT} (IF), whose relative amplitudes and relative phase are identical to those of the original RF signals, but at a frequency more convenient for measurement.

A 100MHz reference from the A8 board and a 2IF (19.53125kHz) from the A14 board are input to the phase-locked loop on the A6 board which outputs an accurate 300MHz-IF (299.990MHz) signal. This 300MHz-IF is output to the A5 board where it is mixed with a 300MHz + RF from the A10 board. The mixer output is filtered, leaving only an RF + IF signal, and then amplified, clipped, and divided down to provide the appropriate RF + IF/N sampling frequency. The output from the A5 board is sent to the A1 Sampling Pulse Generator where it is amplified to drive a step-recovery-diode, and then input to two differentiators to provide the required pulse height and width. The I-Channel and V-Channel Sampling pulses are identical except that the V-Channel sampling pulse is slightly delayed in reference to the I-Channel sampling pulse. The A3 and A4 boards each provide two complementary sampling pulses for their respective channel.

8-34. A1 SAMPLING PULSE GENERATOR

8-35. The A1 board outputs the sampling pulses required for the sampling operations in the I and V channels. For maximum sampling efficiency, the pulses must have an extremely short rise time. To accomplish this, the A1 board has a step recovery diode (SRD), strip-inductor, forward current source, SRD driver, and two differentiators. The forward current source turns on the SRD and stores a charge in the SRD. The SRD driver circuit reverse biases the SRD with a periodic square wave whose frequency is $(RF+IF)/N$. The SRD allows reverse

bias current to momentarily flow and it snaps off as soon as the stored charge is lost. The waveform across the SRD is, thus, a square wave with very sharp leading edge. This signal is then applied to two differentiators which provide the sampling pulses for the I channel and V channel respectively.

8-36. A51 PROBE I-CHANNEL

8-37. The RF current through the DUT is detected by a toroid current transformer shunted by a 50Ω resistor. The resulting voltage drop across the shunt resistor is applied to a four-diode sampling gate which is controlled (opened and closed) by two complementary sampling pulses. When the diodes are forward biased by the sampling pulses, the gate is open for approximately 700ps. During this time, the instantaneous voltage across the 50Ω shunt resistor charges a capacitor, where it is held until the next sample is taken. Because the sampling pulses are so short, the capacitor can only charge to approximately 70%. To improve sampling efficiency to between 90% and 100%, IF feedback is used.

8-38. A52 PROBE V-CHANNEL

8-39. The RF voltage across the DUT is applied to a four-diode sampling gate which is controlled (opened and closed) by two complementary sampling pulses. When the diodes are forward-biased by the sampling pulses, the gate is open for approximately 700ps. During this time, the instantaneous RF voltage across the DUT charges a capacitor, where it is held until the next sample is taken. Because the sampling pulses are so short, the capacitor can only charge to approximately 70%. To improve sampling efficiency to between 90% and 100%, IF feedback is used.

8-40. A5 MIXER/DIVIDER

8-41. The A5 board has two functions : (1) mix the 300MHz-IF from the A6 board with the 300MHz+RF from the A10 board to produce an RF+IF signal and (2) divide the RF+IF by N_s . The double-balanced mixer heterodynes the two input signals, producing a 300MHz-IF, 300MHz+RF, 600MHz+RF-IF, and RF+IF. The three higher-frequencies are blocked by a 120MHz low-pass filter, leaving only the RF+IF, which is then amplified and squared for input to the N_s divider. The N_s divisor is selected by the microprocessor, and, depending on the frequency of the test signal (RF), will have a value from 1 to 44. After division, the sampling signal, $(RF+IF)/N_s$, is input to a transfer buffer for output to the A1 Sampling Pulse Generator.

8-42. A6 Voltage Controlled Crystal Oscillator

8-43. The A6 board is the initial stage of the Sampling Circuit. It produces the requisite 300MHz-IF reference signal for the mixer on the A5 board. The phase-locked loop on the A6 board outputs a precise 100MHz-IF/3 signal which is converted into the 300MHz-IF signal by a tripler and a 300MHz BPF.

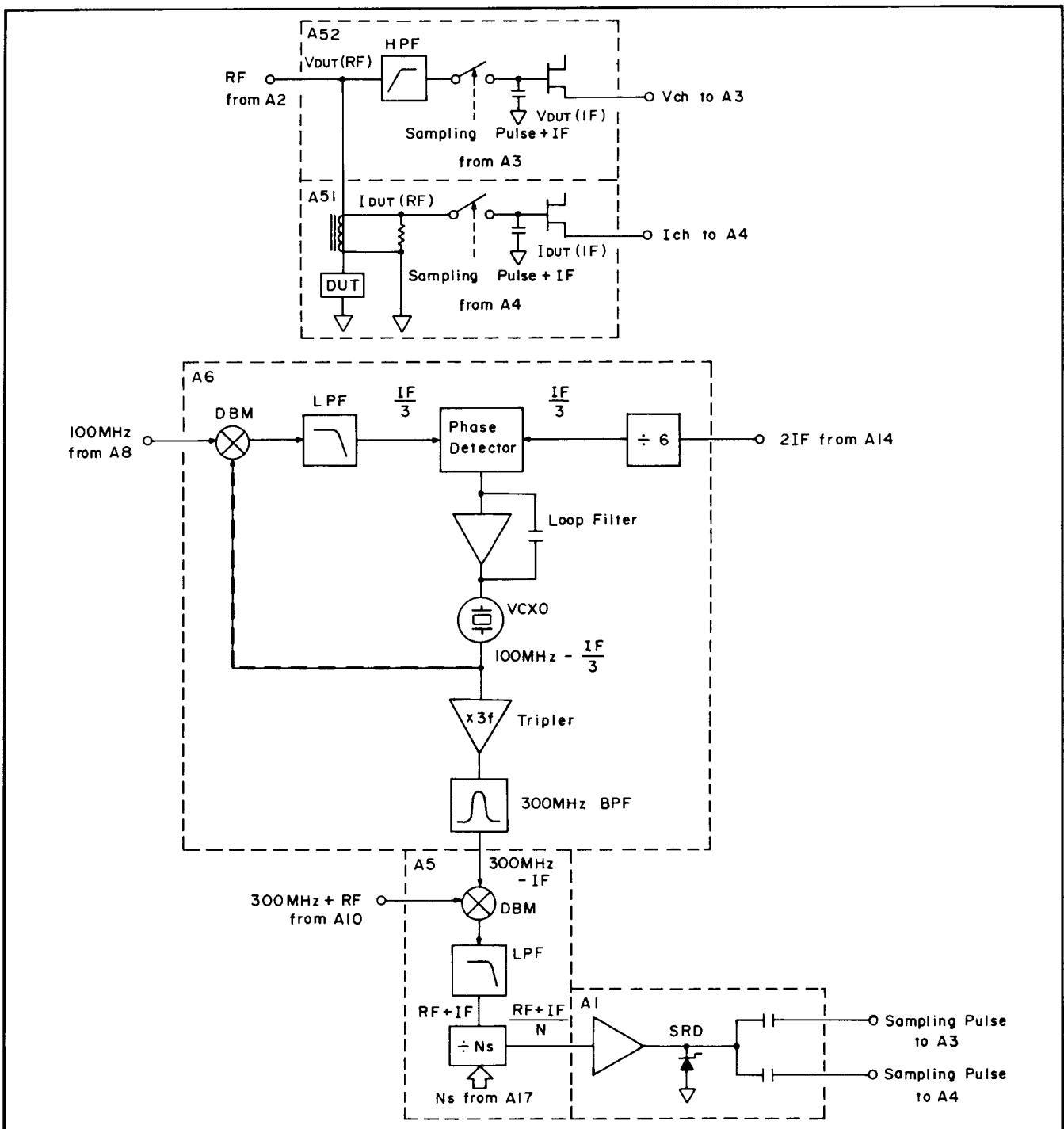

Figure 8-6. Sampling Block Diagram.

Synchronized Mixed Down Sampling Pulse Generation

In conventional sampling circuits, a phase locked loop is usually used to generate a sampling signal whose frequency must be $(RF+IF)/N$, where N is a positive integer, as shown in Figure A. It takes time to lock the PLL when the test frequency is changed. In the 4193A, however, a mixing down method using no feedback loop and no presampling is used to generate the sampling pulses as shown in Figure B. Two signals, a $300\text{MHz} + RF$ and a $300\text{MHz}-IF$, are used to generate the sampling signal. They are mixed to produce an $RF+IF$ signal and converted to $RF+IF/N$ by a frequency divider, the denominator N is determined by the logic control board. Therefore, the sampling pulse frequency is fixed at $RF+IF/N$ even if the test frequency is changed, which is the determinant of stable sampling in RF test frequency changes. This feature enables the 4193A to sweep the RF test frequency in the wide frequency range from 0.4 to 110MHz.

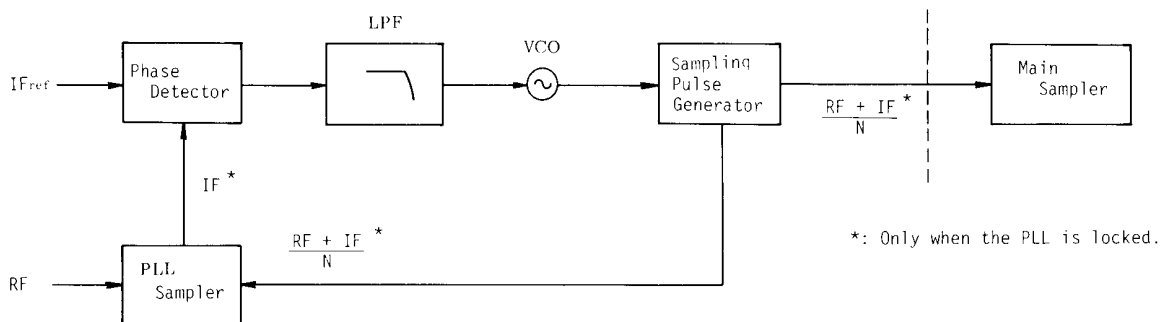

Figure A. Phase Locked Loop Method.

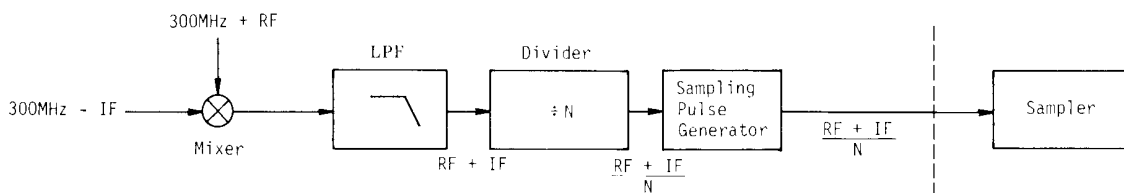

Figure B. Mixing Down Method.

Figure 8-7. Sampling Pulse Generation.

Sampling Pulses

Figure A shows the sampling pulses applied to the V-Channel and I-Channel samplers. Normally, the sampling diodes are reverse biased by 3.8 volts. To turn the sampling diodes fully on and, thus, maximize sampling efficiency, the height of the sampling pulses is 4.5 volts (in reference to the reverse bias voltage). Sampler on-time, when all diodes are conducting, is approximately 700 picoseconds. Sampling pulse height at the output of the A1 SPG is approximately 24 volts, which is attenuated to the requisite 4.5 volts by the transmission paths.

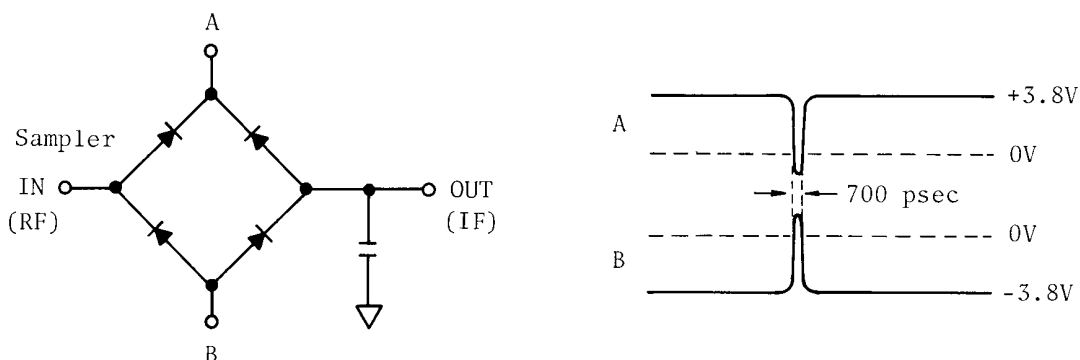

Figure A. Sampling Pulses.

To eliminate inter-channel interference, sampling in the V-Channel is delayed 2.2 nanoseconds in reference to sampling in the I-Channel. The phase error caused by this delay is compensated for by the logic section. Delay is introduced by the A41 Delay Line (on the A1 board) and the cable between A1P1 and A3P2. The delay line causes a 1.2 nanosecond delay and the cable causes a 1 nanosecond delay.

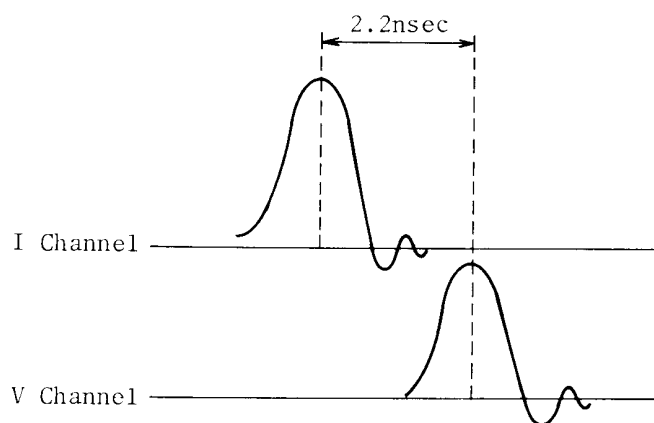

Figure B. Sampling Delay Time (at Samplers).

Figure 8-8. Sampling Pulses.

SECTION VIII

8-44. DETECTION BLOCK

8-45. The Detection Block consists of the A3 V-Channel, A4 I-Channel, A12 IF BPF, A13 Detector, and A14 ADC. Overall operation is as follows.

Two IF signals, one representing DUT current (I_{ch}) and one representing DUT voltage (V_{ch}), are fed from the probe to the A3 and A4 boards where they are amplified and attenuated in accordance with the magnitude range information provided by the A17 board. The A12 board is divided into two channels: I channel and V/I channel. The I channel continuously outputs the I_{ch} signal to the control circuit on the A13 board where it is used for ALC feedback, and range control. The V/I channel is identical to the I channel except that it contains an analog switch. This switch is controlled by a signal from the A14 board and it alternately selects the incoming I_{ch} and V_{ch} signals for output to the magnitude and phase detection circuits on the A13 board. Since the I_{ch} and V_{ch} signals are both fed through the V/I channel to the detection circuits, no measurement error results. Also, any error introduced by the I channel is detected during phase detection (the I_{ch} signal is phase detected in reference to itself) and compensated by the microprocessor.

On the A13 board, the I_{ch} signal fed from the I channel on the A12 board is rectified and squared for use as the reference in the phase detector. The rectified I_{ch} signal is also applied to an integrator whose output is used for automatic level control and magnitude range control. The V/I signal (this signal is either I_{ch} and V_{ch}) fed from the A12 board is input to the magnitude detector and the phase detector. Detected magnitude and phase are then output to the A14 board.

The A14 board contains two AD converters, one for magnitude and one for phase. The integrator outputs-- V_V magnitude, V_I magnitude, V_V phase, and V_I phase--are sent to the A17 board.

8-46. A3 IF V-CHANNEL AMPLIFIER

8-47. The A3 board has three functions. One is to convert the sampling pulse fed from the A1 board into two complementary sampling pulses. The second is to provide IF feedback and reverse DC bias to the V-Channel sampling diodes in the probe. IF feedback stabilizes the sampling operation and raises sampling efficiency. The third is to attenuate the IF signal by 1, 10, 100, 500, or 1000. The amount of attenuation is determined by the selected magnitude range.

8-48. A4 IF I-CHANNEL AMPLIFIER

8-49. The A4 board has three functions. One is to convert the sampling pulse fed from the A1 board into two complementary sampling pulses. The second is to provide IF feedback and reverse DC bias to the I-Channel sampling diodes in the probe. IF feedback stabilizes the sampling operation and raises sampling efficiency. The third is to amplify the IF signal by 4, 8, or 40. The amount of amplification is determined by the selected magnitude range. This board also contains a phase-shifter which prevents synchronization error between the I-Channel and V-Channel.

8-50. A12 IF BPF

8-51. The A12 board is the first IF detection stage, and it has two functions. The first is to amplify and filter the I-Channel IF signal from the A4 board. This signal is then output to the A13 board, where it is converted into the ALC signal, RANGE UP signal, and RANGE DOWN signal. The second function is to alternately select the I-Channel and V-Channel signals, amplify and filter them, and then output them to the A13 board, where they are phase detected and rectified for measurement. Selection is made by two analog switches which are controlled by the I_{meas} and V_{meas} signals from the A14 board. The amplifiers used in both functions are identical, as are the bi-quad type filters.

8-52. A13 DETECTOR

8-53. The A13 board is the second IF detection stage and has two main functions: phase detect the V_{ch} signal in reference to the I_{ch} signal and rectify and output the V_{ch} and I_{ch} signals to the A14 board for measurement. The I_{ch} and V/I signals fed from the A12 board are each squared and input to one half of a dual one-shot multivibrator. The duty cycles of the multivibrator's outputs are identical and determined by two RC networks connected to the multivibrator. The multivibrator outputs are connected to the inputs of an RS flip-flop that outputs a pulse whose width is proportional to the phase difference between the two inputs. This pulse controls an analog switch which provides the PHASE+ and PHASE- signals to the phase A/D converter on the A14 board. The V/I signal is actually two signals, I_{ch} and V_{ch} , alternately selected on the A12 board for output to the A13 board. This I_{ch} signal is identical to the I_{ch} signal used as the reference in the phase detector. When the V/I signal is the I_{ch} signal, it is phase detected in reference to the other I_{ch} signal in order to measure any phase offset error

MANUAL CHANGES

4193A

VECTOR IMPEDANCE METER

MANUAL IDENTIFICATION

Model Number: 4193A

Date Printed: AUG. 1983

Part Number: 04193-90000

This supplement contains important information for correcting manual errors and for adapting the manual to instruments containing improvements made after the printing of the manual.

To use this supplement:

Make all ERRATA corrections.

Make all appropriate serial number related changes indicated in the tables below.

SERIAL PREFIX OR NUMBER	MAKE MANUAL CHANGES	SERIAL PREFIX OR NUMBER	MAKE MANUAL CHANGES
ALL	1	2516J01115 and above	5
2206J00470 and above	2	2516J01228 and above	6
2206J00838 and above	3	2516J01294 and above	7
2516J00975 and above	4	2516J01319 and above	8

► NEW ITEM

ERRATA

Page 8-5, Paragraph 8-30

Partially change line 16 to read:

signal fed back from the A9 board to the A7

Page 8-6, Figure 8-5. Signal Source Operation

Partially change line 5 to read:

the front-panel, the ±N circuit outputs a stable 1KHZ,
10KHZ,

NOTE

Manual change supplements are revised as often as necessary to keep manuals as current and accurate as possible. Hewlett-Packard recommends that you periodically request the latest edition of this supplement. Free copies are available from all HP offices. When requesting copies quote the manual identification information from your supplement, or the model number and print date from the title page of the manual.

Date/Div: Dec. 17, 1986/33

Page 1 of 6



► CHANGE 8

Page 8-77, Figure 8-47 A8 Crystal Oscillator Assembly Schematic Diagram,
Change R22 56 Ω to R22* 38.3 Ω .

Change	Page	Note	Reference Designation	HP part Number	Description
3	6-14	C	A6CR10	1902-0064	DIODE-ZNR 7.5V 5%
5	6-42	C	37	2190-0586	WSHR-LK-HLCL
		C	38	0515-1509	HEX-SHC-SCR M4
		C	52	04193-00205	REAR PANEL
6	6-4	C		1205-0095	HEAT SINK
	6-6	C		1205-0095	HEAT SINK
	6-28	C		1205-0095	HEAT SINK
	6-30	C		1205-0095	HEAT SINK
7	6-39	C	A20J12	1252-0943	CONNECTOR 6PIN x 2ea.
8	6-18	► D	A8R22	0698-3435	RES 38.3 5% .25W
		► A	A8R22*	0698-3435	RES 38.3 1% .125W

► : CHANGE

MANUAL CHANGES

HP 4193A

Vector Impedance Meter

MANUAL IDENTIFICATION

Model Number: HP 4193A
Date Printed: Not Specified
Part Number: 04193-90000

This supplement contains information for correcting manual errors and for adapting the manual to newer instruments that contain improvements or modifications not documented in the existing manual.

To use this supplement

1. Make all ERRATA corrections
2. Make all appropriate serial-number-related changes listed below

SERIAL PREFIX OR NUMBER MAKE MANUAL CHANGES

SERIAL PREFIX OR NUMBER	MAKE MANUAL CHANGES
All	1

SERIAL PREFIX OR NUMBER MAKE MANUAL CHANGES

SERIAL PREFIX OR NUMBER	MAKE MANUAL CHANGES

► **New Item**

- Some LCR components used in the HP 4193A have been standardized to decrease the number of similar components. For example, if a unit uses both 6.8k Ω 5% and 6.81k Ω 1% resistors, the standard resistor will now be 6.81k Ω 1%.

Change the part numbers in the Replaceable Parts List of Section 6 as given in the table on the next page.

NOTE

Manual change supplements are revised as often as necessary to keep manuals as current and accurate as possible. Hewlett-Packard recommends that you periodically request the latest edition of this supplement. Free copies are available from all HP offices. When requesting copies, quote the manual identification information from your supplement, or the model number and print date from the title page of the manual.

Table 1. Parts Standardization Change

Old Part		New Part	
Part Number	Description	Part Number	Description
0160-4574	Capacitor 1000pF 20%	0160-4822	Capacitor 1000pF 5%
0683-1005	Resistor 10Ω 5%	0757-0346	Resistor 10Ω 1%
0683-1015	Resistor 100Ω 5%	0757-0401	Resistor 100Ω 1%
0683-1025	Resistor 1kΩ 5%	0757-0280	Resistor 1kΩ 1%
0683-1035	Resistor 10kΩ 5%	0757-0442	Resistor 10kΩ 1%
0683-1045	Resistor 100kΩ 5%	0757-0465	Resistor 100kΩ 1%
0683-1055	Resistor 1MΩ 5%	0698-8827	Resistor 1MΩ 1%
0683-1205	Resistor 12Ω 5%	0757-0379	Resistor 12.1Ω 1%
0683-1215	Resistor 120Ω 5%	0757-0403	Resistor 121Ω 1%
0683-1225	Resistor 1.2kΩ 5%	0757-0274	Resistor 1.21kΩ 1%
0683-1235	Resistor 12kΩ 5%	0757-0444	Resistor 12.1kΩ 1%
0683-1515	Resistor 150Ω 5%	0698-3438	Resistor 147Ω 1%
0683-1525	Resistor 1.5kΩ 5%	0757-1094	Resistor 1.47kΩ 1%
0683-1535	Resistor 15kΩ 5%	0698-3156	Resistor 14.7kΩ 1%
0683-1815	Resistor 180Ω 5%	0698-3439	Resistor 178Ω 1%
0683-1825	Resistor 1.8kΩ 5%	0757-0278	Resistor 1.78kΩ 1%
0683-1845	Resistor 180kΩ 5%	0698-3243	Resistor 178kΩ 1%
0683-2205	Resistor 22Ω 5%	0698-3430	Resistor 21.5Ω 1%
0683-2215	Resistor 220Ω 5%	0698-3441	Resistor 215Ω 1%
0683-2225	Resistor 2.2kΩ 5%	0698-0084	Resistor 2.15kΩ 1%
0683-2235	Resistor 22kΩ 5%	0757-0199	Resistor 21.5kΩ 1%
0683-2245	Resistor 220kΩ 5%	0698-3454	Resistor 215kΩ 1%
0683-2705	Resistor 27Ω 5%	0698-3432	Resistor 26.1Ω 1%
0683-2715	Resistor 270Ω 5%	0698-3132	Resistor 261Ω 1%
0683-2735	Resistor 27kΩ 5%	0698-3159	Resistor 26.1kΩ 1%
0683-2745	Resistor 270kΩ 5%	0698-3455	Resistor 261kΩ 1%
0683-3305	Resistor 33Ω 5%	0757-0180	Resistor 31.6Ω 1%
0683-3315	Resistor 330Ω 5%	0698-3444	Resistor 316Ω 1%
0683-3915	Resistor 390Ω 5%	0698-3446	Resistor 383Ω 1%
0683-4705	Resistor 47Ω 5%	0698-4037	Resistor 46.4Ω 1%
0683-4715	Resistor 470Ω 5%	0698-0082	Resistor 464Ω 1%
0683-4725	Resistor 4.7kΩ 5%	0698-3155	Resistor 4.64kΩ 1%
0683-5105	Resistor 51Ω 5%	0757-0394	Resistor 51.1Ω 1%
0683-5605	Resistor 56Ω 5%	0757-0395	Resistor 56.2Ω 1%
0683-5615	Resistor 560Ω 5%	0757-0417	Resistor 562Ω 1%
0683-5625	Resistor 5.6kΩ 5%	0757-0200	Resistor 5.62kΩ 1%
0683-5645	Resistor 560kΩ 5%	0698-8824	Resistor 562kΩ 1%
0683-6805	Resistor 68Ω 5%	0757-0397	Resistor 68.1Ω 1%
0683-6815	Resistor 680Ω 5%	0757-0419	Resistor 681Ω 1%
0683-6825	Resistor 6.8kΩ 5%	0757-0439	Resistor 6.81kΩ 1%