

Part No. Z1-004-512, IA004471

Apr. 2009



Marked Products

## **OPERATION MANUAL**

Regulated DC Power Supply  
PAN-A Series

175W MODEL    **PAN 16-10A**  
                  **PAN 35-5A**  
                  **PAN 60-3A**

350W MODEL    **PAN 16-18A**  
                  **PAN 35-10A**  
                  **PAN 60-6A**

700W MODEL    **PAN 16-30A**  
                  **PAN 35-20A**  
                  **PAN 60-10A**

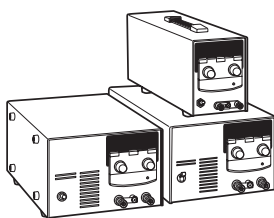

## About This Manual

If you find any incorrectly arranged or missing pages in this manual, they will be replaced. If the manual gets lost or soiled, a new copy can be provided for a fee. In either case, please contact Kikusui agent/distributor, and provide the "Part No." given on cover.

This manual has been prepared with the utmost care; however, if you have any questions, or note any errors or omissions, please contact Kikusui agent/distributor.

All or any parts of this manual may not be reproduced in any forms, without express written permission of Kikusui Electronics Corporation.











The contents of this manual are subject to change without notice.

© 2009 Copyright Kikusui Electronics Corporation.

All rights reserved.

## Safety Symbols

For the safe use and safe maintenance of this product, the following symbols are used throughout this manual and on the product. Understand the meanings of the symbols and observe the instructions they indicate (the choice of symbols used depends on the products).

 or 	Indicates that a high voltage (over 1 000 V) is used here. Touching the part causes a possibly fatal electric shock. If physical contact is required by your work, start work only after you make sure that no voltage is output here.
<b>DANGER</b>	Indicates an imminently hazardous situation which, if ignored, will result in death or serious injury.
 <b>WARNING</b>	Indicates a potentially hazardous situation which, if ignored, could result in death or serious injury.
 <b>CAUTION</b>	Indicates a potentially hazardous situation which, if ignored, may result in damage to the product and other property.
	Shows that the act indicated is prohibited.
	Indicates a general danger, warning, or caution. When this symbol is marked on the product, see the relevant sections in this manual.
	Protective conductor terminal.
 or 	Chassis (frame) terminal.
	On (supply)
○	Off (supply)
	In position of a bi-stable push control
	Out position of a bi-stable push control

## **Safety Precautions**

The following safety precautions must be observed to avoid fire hazard, electrical shock, accidents, and other failures. Keep them in mind and make sure that all of them are observed properly.

Using the product in a manner that is not specified in this manual may impair the protection functions provided by the product.



### Users

- This product must be used only by qualified personnel who understand the contents of this operation manual.
- If it is handled by disqualified personnel, personal injury may result. Be sure to handle it under supervision of qualified personnel (those who have electrical knowledge.)
- This product is not designed or produced for home-use or use by general consumers.



### Purposes of use

- Do not use the product for purposes other than those described in the operation manual.

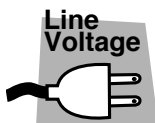

### Input power

- Use the product with the specified input power voltage.
- For applying power, use the AC power cord provided. For details, see the relevant page of this operation manual.



### Fuse

- With products with a fuse holder on the exterior surface, the fuse can be replaced with a new one. When replacing a fuse, use the one which has appropriate shape, ratings, and specifications.



### **Cover**

- There are parts inside the product which may cause physical hazards. Do not remove the external cover.

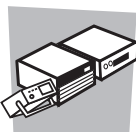

### **Installation**

- When installing products be sure to observe "1.3 Precautions for installation" described in this manual.
- To avoid electrical shock, connect the protective ground terminal to electrical ground (safety ground).



### **Relocation**

- Turn off the power switch and then disconnect all cables when relocating the product.
- Use two or more persons when relocating the product which weights more than 20 kg. The weight of the products can be found on the rear panel of the product and/or in this operation manual.
- Use extra precautions such as using more people when relocating into or out of present locations including inclines or steps. Also handle carefully when relocating tall products as they can fall over easily.
- Be sure the operation manual be included when the product is relocated.



### **Operation**

- Check that the AC input voltage setting and the fuse rating are satisfied and that there is no abnormality on the surface of the power cord. Be sure to unplug the power cord.
- If any abnormality or failure is detected in the products, stop using it immediately. Unplug the power cord. Be careful not to allow the product to be used before it is completely repaired.
- For output wiring or load cables, use connection cables with larger current capacity.
- Do not disassemble or modify the product. If it must be modified, contact Kikusui distributor/agent.



### **Maintenance and checking**

- To avoid electrical shock, be absolutely sure to unplug the power cord before performing maintenance or checking.
- Do not remove the cover when performing maintenance or checking.
- To maintain performance and safe operation of the product, it is recommended that periodic maintenance, checking, cleaning, and calibration be performed.



### **Service**

- Internal service is to be done by Kikusui service engineers. If the product must be adjusted or repaired, contact Kikusui distributor/agent.

# Arrangement of this manual

This Operation Manual is made up of the following sections.

## **Preface**

Describes all the models covered by this manual, as well as outlines the features of each model.

## **Chapter 1 "Setup"**

This chapter describes the necessary procedure from unpacking to preparation before use. Since details on installation location and power supply are provided, be sure to read this chapter before using the unit for the first time.

## **Chapter 2 "Before Using the Unit"**

Before using the power supply, users are requested to thoroughly understand the following units.

## **Chapter 3 "Basic Operation"**

Describes the unit's start-up function, protection circuit, and the basic operations managed from the front panel of the unit.

## **Chapter 4 "Applied Operation"**

Explains the remote control of the unit, and use of multiple number of power supply in combination to increase output capacity.

## **Chapter 5 "Names and Functions of Controls"**

Provides an outline of the switches and terminals on the panels, including their names and functions.

Read this chapter to learn the meanings of the  caution marks indicated on the panels of the unit.

## **Chapter 6 "Maintenance"**

Describes the daily inspection procedures and the adjustment conducted when necessary. To remote-control the unit, such adjustment is necessary. Follow the adjustment procedures detailed in this chapter. The chapter also describes some symptoms of possible problems encountered during use of the unit, along with appropriate remedies.

# Chapter 7 "Specifications"

Describes the electrical, mechanical and general specifications of the unit.



# CONTENTS

Safety Symbols- - - - -	I
Safety Precautions - - - - -	II
Arrangement of this manual - - - - -	V
Preface - - - - -	P-1
Chapter 1 Setup - - - - -	1-1
1.1 Checks during unpacking - - - - -	1-1
1.2 Precautions for moving - - - - -	1-4
1.3 Precautions for installation - - - - -	1-5
1.4 Checking the input fuse- - - - -	1-7
1.5 Connecting the AC power code - - - - -	1-8
1.6 Grounding- - - - -	1-10
Chapter 2 Before Using the Unit - - - - -	2-1
2.1 Inrush current - - - - -	2-1
2.2 Negative voltage - - - - -	2-1
2.3 Output terminals on the front panel - - - - -	2-2
2.4 Load - - - - -	2-2
2.4.1 When load current has peaks or is pulse-shaped- - - - -	2-2
2.4.2 When a load generates a reverse current to the power supply - - - - -	2-3
2.4.3 In case of load with accumulated energy, such as batteries - - - - -	2-4
2.5 CV power supply and CC power supply- - - - -	2-5
2.6 Output Terminal Isolation - - - - -	2-8
Chapter 3 Basic Operation - - - - -	3-1
3.1 Turning on the power - - - - -	3-1
3.2 Basic operation - - - - -	3-4
3.2.1 OVP(Over Voltage Protection) trip point presetting - - - - -	3-4
3.2.2 Using as a constant voltage power supply- - - - -	3-6
3.2.3 Using as a constant current power supply - - - - -	3-7
3.3 Connecting load- - - - -	3-8
3.4 Mounting the auxiliary output terminal cover - - - - -	3-13
3.5 Fixing output presetting - - - - -	3-14
Chapter 4 Applied Operation - - - - -	4-1
4.1 CONTROL terminal board - - - - -	4-1
4.2 Remote sensing - - - - -	4-5

4.3	Analog remote control	4-8
4.3.1	Controlling output voltage with external resistor	4-10
4.3.2	Controlling output voltage with external voltage	4-12
4.3.3	Controlling output current with external resistor	4-16
4.3.4	Controlling output current with external voltage	4-18
4.3.5	Output ON/OFF control	4-22
4.4	Master-slave-control parallel operation	4-24
4.5	Master-slave-control series operation	4-30
Chapter 5	Names and Functions of Controls	5-1
5.1	Front panel	5-1
5.2	Rear panel	5-6
Chapter 6	Maintenance	6-1
6.1	Cleaning	6-1
6.2	Inspection	6-1
6.3	Adjustment	6-2
6.3.1	Test equipment required	6-2
6.3.2	Adjustment procedure	6-2
6.4	Malfunctions and Causes	6-9
Chapter 7	Specifications	7-1
INDEX		-1-1

# Preface

## Outline of the manual

The PAN-A series is classified depending on output capacity. This Operation Manual describes the PAN-A series, including the specific types named below.



### MODEL 175W

PAN16-10A  
PAN35-5A  
PAN60-3A

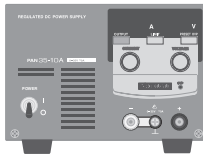

### MODEL 350W

PAN16-18A  
PAN35-10A  
PAN60-6A

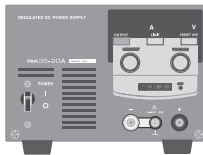

### MODEL 700W

PAN16-30A  
PAN35-20A  
PAN60-10A

Fig.P-1 Models and types covered by this manual

## Introduction of the products

The PAN-A series is an automatic constant voltage/constant current shifting regulated DC power supply equipped with the phase control pre-regulator. A series regulator system is used to assure low-noise and stable output.

The PAN-A series are featured with the following points.

- The two distinctly visible LED display units on the front panel display output voltage, output current and various preset data.
- The output control potentiometer (for voltage and current presetting) is of a 10-turns wire-wound design, and allows precise setting.
- For both the front and rear panels, the output terminals can be equipped with a cover for safety.
- Using external voltage or external resistor, output voltage and current can be remote-controlled.  
For remote-control operations using an external voltage, you can also perform adjustments output using the knob on the front panel.
- The remote control and remote sensing terminals use screwless terminal boards, which facilitates wiring.
- Using the Kikusui power supply controller with the control board allows you to construct an automatic tester and other systems.
- The PAN-A series uses a choke input smoothing circuit in the phase control pre-regulator; input apparent power is less than for capacitor input smoothing circuits, improving the power factor at low outputs.
- High-speed transient response of  $50\mu\text{s}$  allows it to follow a sudden load change.
- Carefully selected parts, improved circuit, and forced air cooling heat dissipation combine to produce an excellent low temperature drift of  $100\text{ ppm}/^\circ\text{C}$  (TYP value).

- To protect a load from unexpectedly excessive voltage, the unit includes a built-in OVP (over-voltage protection) circuit capable of handling voltages 10 % - 110 % of the rated output voltage. The OVP (over-voltage protection) circuit has a preset feature, allowing you to check the OVP set voltage even when the unit is being used.

With the above-mentioned features, PAN-A series units offers a wide range of applications to laboratory experimental equipment, test equipment for mass-production lines, power supply for aging, etc.

- 
- NOTE** • Since this unit uses a phase control circuit for the pre-regulator, output is superimposed with pulsive noise. Although the noise level is kept a few tens of mV, it may still cause some problem with certain types of applications. Please study this issue carefully before choosing which unit to use.
- 

## Option

The following optional accessories are available for rack mounting.

- Rack mount frame RMF4M (Metric rack conforming to JIS standards)  
RMF4 (Inch rack conforming to EIA standards)
- Blank panel BP2, BP4
- Bracket B22, B42

- 
- CAUTION** • The unit is furnished with air intake ports for forced air cooling. For rack mounts, therefore, we request that you mount a blank panel of at least one panel wide\*<sup>1</sup> on the rack.
- 

For details on optional accessories, contact your Kikusui agent.

---

\*1. One panel wide; JIS standard: 50 mm, EIA standard: 44.45 mm

# MODEL 175W

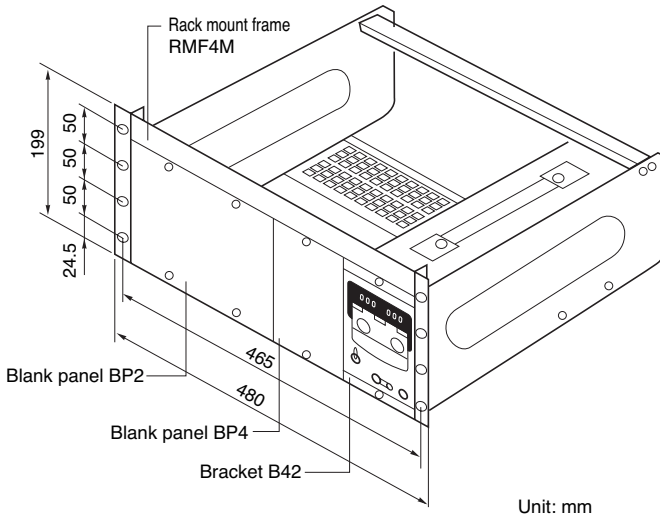
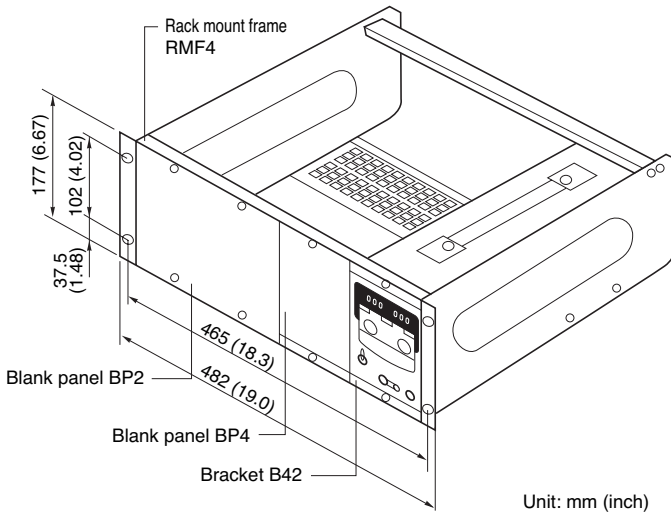

Fig.P-2 Model 175W mounted into RMF4M/RMF4

MODEL 350W/700W

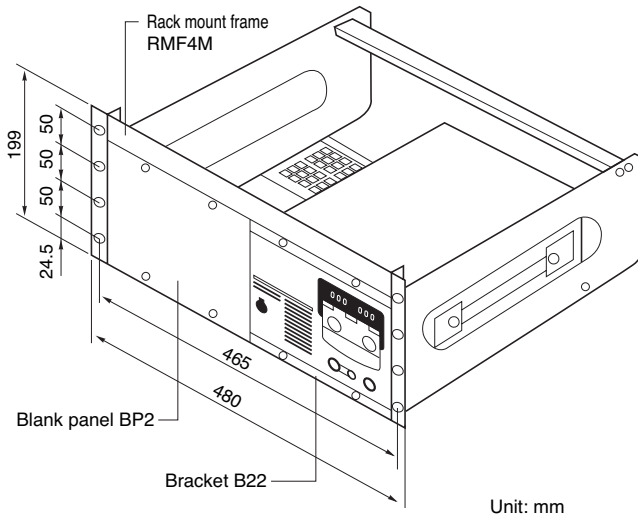
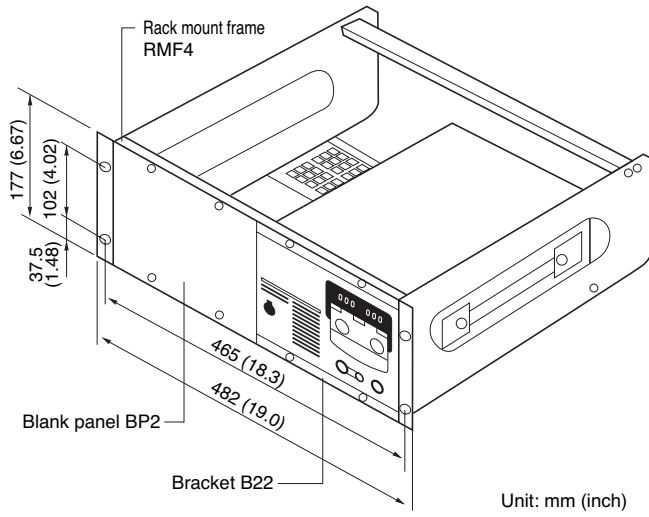

Fig.P-3 Model 350W/700W mounted into RMF4M/  
RMF4





## 1.1 Checks during unpacking

When you unpack the product, make sure that you have all the parts and that none have been damaged during transportation. If any parts is damaged or missing, contact your Kikusui agent/distributor.

Accessories vary depending on the model.

### MODEL 175W

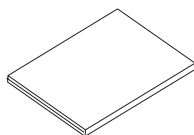

Operation manual  
[Z1-004-512]



Guard cap 2 pcs.  
GP01-PMC  
[83130]

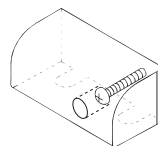

Auxiliary output  
terminal cover  
Cover:[P1-000-048]  
Screw:[M3-112-019]

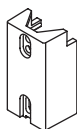

Rear output terminal  
cover  
(Mount on the unit.)  
[Q5-000-160]

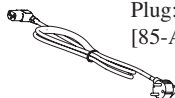

Plug: CEE7/7  
[85-AA-0005]

AC power cable

Fig.1-1 Accessories (model 175W)

---

**NOTE** • We recommend that all packing materials be saved, in case the product needs to be transported at a later date.

---

# MODEL 350W

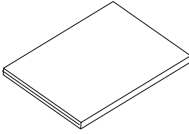

Operation manual  
[Z1-004-512]



Guard cap 2 pcs.  
GP01-PMC  
[83130]

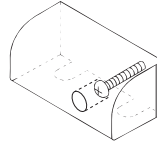

Auxiliary output terminal  
cover  
Cover:[P1-000-047]  
Screw:[M3-112-019]

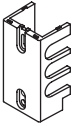

Rear output terminal cover  
(Mount on the unit.)  
[Q5-000-170]



Fuse  
[99-02-1002]

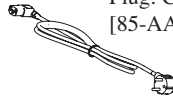

Plug: CEE7/7  
[85-AA-0005]

AC power cable

Fig.1-2 Accessories (model 350W)

---

**NOTE**

- We recommend that all packing materials be saved, in case the product needs to be transported at a later date.
-

## MODEL 700W

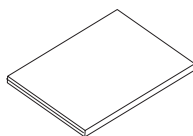

Operation manual  
[Z1-004-512]



Guard cap 2pcs.  
GP01-PMC  
[83130]

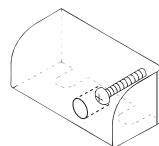

Auxiliary output  
terminal cover  
Cover:[P1-000-047]  
Screw:[M3-112-019]

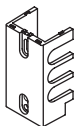

Rear output terminal cover  
(Mount on the unit.)  
[Q5-000-170]



Fuse  
[99-02-1003]  
(PAN35-20A:[99-02-1400])

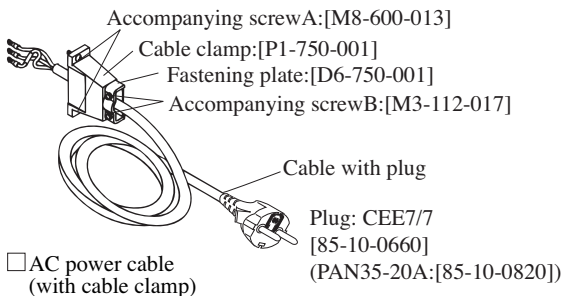

Fig.1-3 Accessories (model 700W)

---

**NOTE** • We recommend that all packing materials be saved, in case the product needs to be transported at a later date.

---

## 1.2 Precautions for moving

To carry the unit, hold the handle as shown below. When moving the unit for a short distance, to the next room, for example, carry it on a wagon whenever available.

- 
- ⚠ WARNING** • For safety, check that the power switch is turned off.
- ⚠ CAUTION** • When transporting the product, be sure to use the original packing materials.
- When packing the product, remove the power cable and all other connection cables.
- 

### MODEL 175W

In the case of the model 175W, hold the handle located on the top.

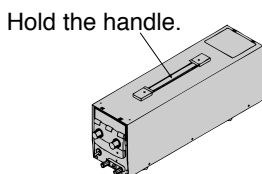

Fig.1-4 Precaution for moving (model 175W)

### MODEL 350W

In the case of the model 350W, the power transformer is located on the left seen from the front, and the center of gravity of the unit is deviated to the left. For carrying the unit, position the left side to be bottom first as shown in Fig.1-5, and carry it with the handle.

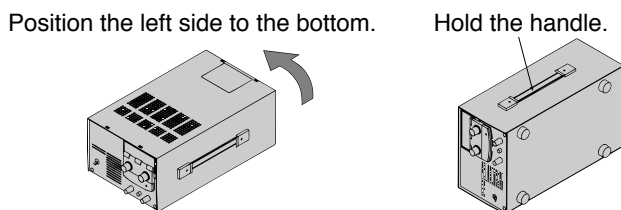

Fig.1-5 Precaution for moving (model 350W)

## MODEL 700W

In the case of the model 700W, the power transformer is located on the left seen from the front, and the center of gravity of the unit is deviated to the left. For carrying the unit, take sufficient care.

---

**⚠ WARNING** • The weight of the model 700W exceeds 20 kg. To prevent any danger, never carry the unit by one person.

---

When moving the unit, two persons should hold the two locations at the rear and front of the unit, respectively, as shown in Fig.1-6.

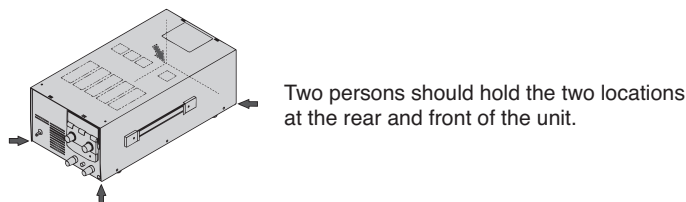

Fig.1-6 Precaution for moving (model 700W)

## 1.3 Precautions for installation

Be sure to observe the following precautions when installing the unit.

■ **Do not use the unit in a flammable atmosphere.**

To prevent explosion or fire, do not use the unit near alcohol or thinner, or in an atmosphere containing such vapors.

■ **Avoid locations where the unit is exposed to high temperature or direct sunshine.**

Do not locate the unit near a heater or in areas subject to drastic temperature changes.

Operation temperature range: 0 °C to 40 °C

Storage temperature range: -10 °C to 60 °C

■ **Avoid locations of high humidity.**

Do not locate the unit in high-humidity locations, i.e., near a boiler, humidifier, water supply, etc.

Operation humidity range: 10 % to 90 % RH

Storage humidity range: 0 % to 90 % RH

Dew condensation may take place even in the operation humidity range. In such a case, do not use the unit until the dew dries up completely.

■ **Do not place the unit in a corrosive atmosphere.**

Do not install the unit in a corrosive atmosphere or one containing sulfuric acid mist, etc. This may cause corrosion of various conductors and imperfect contact with connectors, malfunction and failure, or in the worst case, a fire.

Modification may allow the unit to cope with such an atmosphere. If the unit is to be used in such an atmosphere, contact your Kikusui agent.

■ **Do not locate the unit in a dusty location.**

Otherwise, this may result in electrical shock or fire.

■ **Do not use the unit where ventilation is poor.**

The unit employs a forced air cooling system. Air is taken in from intake ports located on the unit's sides and front, and is exhausted from the rear. Prepare sufficient space around the unit so that the intake ports and exhaust port are always completely unobstructed.

Do not install the unit with its front panel positioned upward or downward.

■ **Do not install the unit along a tilted section of floor or in a location subject to vibrations.**

If placed on a non-level surface or in a location subject to vibration, the unit may fall, resulting in damage and injury.

■ **Do not use the unit in locations affected by strong magnetic and/or electric fields.**

Operation in a location subject to magnetic or electric fields may cause the unit to malfunction resulting in electrical shock or fire.

## 1.4 Checking the input fuse

### MODEL 350W/700W

Use an input fuse element suitable for the AC power source. A seal is attached to the rear panel indicating suitable fuse ratings. See Fig.1-7.

- 
- ⚠ WARNING** • To avoid electric shock, always disconnect the AC power cord or turn off the switch on the switchboard.
- ⚠ CAUTION** • Select a fuse element of external design, rating and characteristics suitable for the unit. Use of a fuse of different rating or a short circuit of the fuse holder may damage the unit.
- 

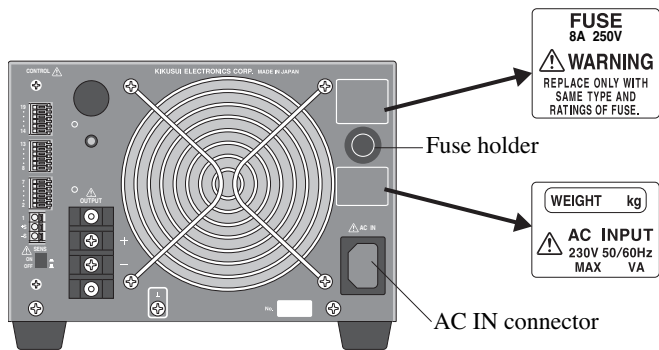

Fig.1-7 Rear panel (model 350W)

### MODEL 175W

The input fuses of the model 175W are located inside, and users are not able to check or replace them.

- 
- ⚠ WARNING** • Users are requested to never remove the cover and check or replace the fuse.
-

## 1.5 Connecting the AC power code

Connect the AC power code to an AC power source specified for the unit. A seal is attached to the rear panel indicating the rated input. See Fig.1-7.

This product is an equipment of IEC Overvoltage Category II (energy-consuming equipment supplied from the fixed installation).

- 
- NOTE**
- Do not use the AC power code provided with the product as a AC power code for other instruments.
  - In an emergency, the AC power cord with a plug may be used to disconnect the product from the AC line in an emergency. Connect the plug to an easily accessible outlet so that the plug can be removed from the outlet at any time. Be sure to allow enough space around the outlet.
- 

### Connecting procedure of PAN-A series side

MODEL 175W/350W

1. Insert the supplied AC power code into the AC IN connector on the rear panel.

MODEL 700W

- 
- ⚠ WARNING** • To avoid electric shock, first connect the cable to the AC IN terminal board before connecting it to the power source.
- ⚠ CAUTION** • Inside the unit, protective circuits including input fuses are connected in order to meet the input terminal rating. Confirm that the wires of the specified color are connected to the corresponding terminals (L, N, and ⊕ (GND)).
- 

1. Connect the supplied AC power code to the terminal board as shown in Fig.1-8.



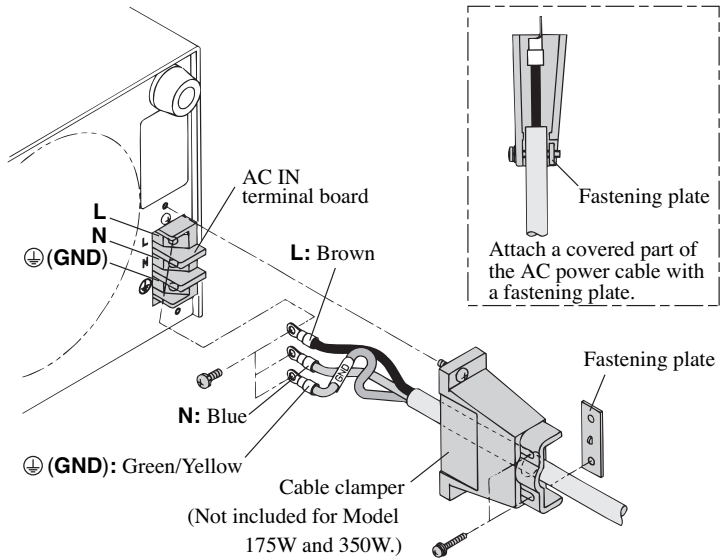



Fig.1-8 Connection of AC power code

### Connecting procedure of AC power source side

1. Insert the plug of the AC power code into an outlet.

## 1.6 Grounding

- 
-  **WARNING** • Improper or no grounding may cause electrical shock.
- Connect the ground terminal to electrical ground (safety ground).
- 

Connect the AC power code to a grounded 3-pin outlet.

# Chapter 2 Before Using the Unit

Before using the unit, users are requested to thoroughly understand the following matters.

## 2.1 Inrush current

An inrush current may flow when the POWER switch is turned on. See Table 2-1. If you are planning to use several sets of the unit in a system, and to turn on the POWER switches at the same time, check that the AC power source or the switchboard is of sufficient capacity. Keep 3 seconds or longer interval between ON and OFF of the POWER switch. Repeated ON/OFF at a shorter interval may cause inrush current and shorten the service lives of the input fuse and power switch.

Table 2-1 Inrush current of each model

	Model 175W	Model 350W	Model 700W
Peak current range	100 A to 150 A	140 A to 200 A	300 A to 400 A
Half-amplitude level	5 ms	5 ms	5 ms

## 2.2 Negative voltage

When the OUTPUT switch's OFF or the OUTPUT switch turn ON as the CURRENT control is turned fully counter-clockwise, a negative voltage of approx. 0.6 V is generated.

Affected by this negative voltage, approx. 10 mA reverse current flows to the load. In cases where the load will be affected by such a reverse current, carefully check the suitability of the application.

After altering the output voltage offset by an external remote control or other means, always make readjustments according to the instructions provided in "6.3 Adjustment".

## 2.3 Output terminals on the front panel

The output terminals on the front panel are auxiliary output terminals. These terminals, however, may not satisfy the given specifications of the unit.

## 2.4 Load

Note that the output may become unstable when one of the following loads is connected.

### 2.4.1 When load current has peaks or is pulse-shaped

The current meter on the unit indicates only mean values. Even when the indicated value is less than the preset current value, therefore, a peak may exceed the preset current value. In such a case, the unit is instantaneously put into constant-current operation mode, and the output voltage drops accordingly. If you look carefully, you will see the constant current (CC) indicator light up dimly.

For such a load, a larger value should be preset for the constant current, or the current capacity should be increased.

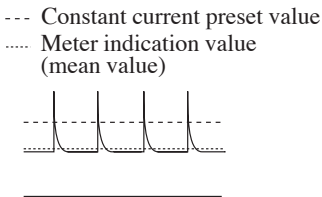

Fig.2-1 Load current with peak value

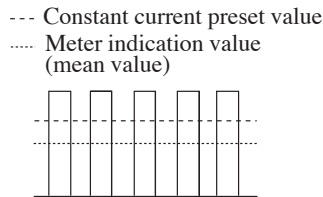

Fig.2-2 Pulse-shaped load current

## 2.4.2 When a load generates a reverse current to the power supply

The unit cannot absorb a reverse current from a regenerative load such as an inverter, converter or transformer that supplies current to a power supply. Consequently, the output voltage will increase and the output will fluctuate.

As a remedy, connect a resistor  $R_D$  as shown in Fig.2-3 to bypass the reverse current. However, the amount of current to the load decreases by  $I_{rp}$ .

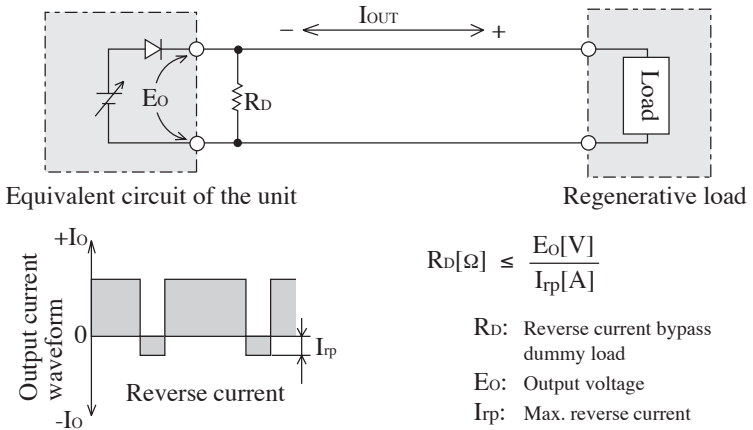

Fig.2-3 Remedy for regenerative load

**⚠ CAUTION** • For the resistor  $R_D$ , select a resistor of the rated power (allowing sufficient margin). If a resistor of insufficient rated power is used in the circuit, it may burn out.

### 2.4.3 In case of load with accumulated energy, such as batteries

Connecting a load with accumulated energy, such as a battery, to the output of the unit may cause a large current to flow from the load through the internal output control circuit protection diode to the internal capacitor. Such currents may damage the internal components of the unit, and reduce the life of the load.

As a remedy, connect a reverse-current-prevention diode D between the unit and the load as shown in Fig.2-4. In this case, however, the unit cannot be used in combination with remote sensing units.

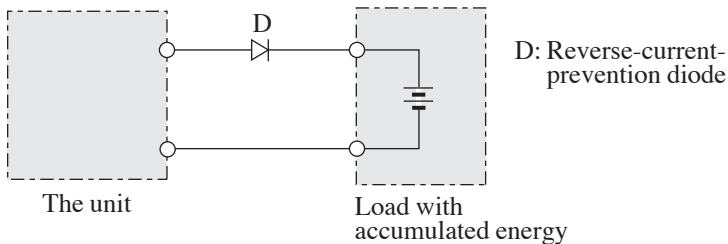

Fig.2-4 Measures against load with accumulated energy

- 
- ⚠ CAUTION** • To protect the unit and the load, select the reverse-current-prevention diode D according to the following standard.
1. Reverse voltage withstand capacity: Minimum of twice the rated output voltage of the unit.
  2. Forward current capacity: Three to ten times the rated output current of the unit.
  3. A diode with small loss
- Be sure to take account of heat generation from the diode D. The diode may burn unless adequately dissipated.
-

## 2.5 CV power supply and CC power supply

The unit is capable of both constant voltage and constant current operation. This section describes these operations.

The ideal constant voltage power supply has zero output impedance at all frequencies and maintains a definite constant output voltage with respect to variations in load current. The ideal constant current power supply has infinite output impedance at all frequencies and compensates for load resistance variation by changing the voltage to maintain a constant output current.

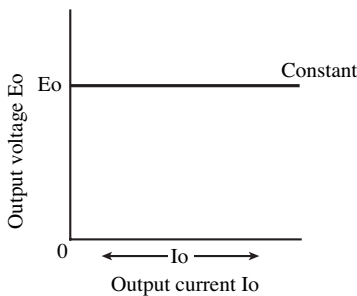

Fig.2-5 Ideal Constant Voltage Power Supply

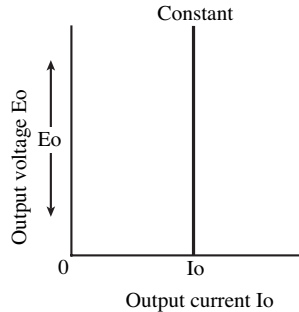

Fig.2-6 Ideal Constant Current Power Supply

However, the output impedance of an actual constant voltage or constant current power supply is neither zero nor infinite, and they have a definite frequency response. In addition, maximum voltage or maximum current constraints on output are a factor, leaving these power supplies unable to maintain constant voltage or current with respect to all changes in load current or load resistance.

### Basic operations of the constant voltage (CV) and constant current (CC) modes

The following describes the relationship between the basic operations in constant voltage (CV) and constant current (CC) modes and limit setting of the unit.

The following description assumes a power supply with a DC output of 60 V and 10 A (maximum rated output voltage of 60 V, maximum rated output current of 10 A) as a model.

## ■ Connecting a 6 Ω resistive load

A resistive load of 6 Ω is connected to the output terminals of the power supply and the output current limit is set to 5 A. In this condition, output voltage is raised gradually from 0 V.

In this case, the power supply operates in the constant voltage (CV) mode. The output current increases as the output voltage increases, and when the output voltage reaches 30 V (that is, the output current has reached 5 A), the output voltage no longer increases beyond 30 V even if you attempt to raise it. This is because the output current is limited to the 5 A set at the beginning of operations, causing the power supply to switch to the constant current (CC) operation mode.

In this way, the power supply automatically moves from the constant-voltage to constant current operation to prevent an overcurrent from flowing. (The point at which the operation modes switch is called the "crossover point"). If the current limit is raised in this condition, the power supply returns to the previous constant voltage operation, allowing you to increase the output voltage further. If the current limit is increased from 5A to 9A in Fig.2-7, a voltage of up to 54V can be output.

## ■ Connecting a 2 Ω resistive load

Let's assume a case in which a load resistance of 2 Ω is used. The output current limit is regarded as the rated maximum output current.

When you increase the output voltage from 0 V, the output current reaches the power supply's maximum current rating when the output voltage reaches 20 V; the power supply cannot output a voltage above 20V with the maximum current flowing. This is its limit, even though the power supply is not yet generating half its output capacity in terms of power.

If you wish to increase the output voltage further, another power supply needs to be connected in parallel to the relevant unit, or the initial unit needs to be replaced by a model having larger current capacity. Particularly for loads into which a transient peak current flows, the current must be set such that its peak does not reach (or exceed) the current limit. If the unit enters constant current operation mode even when the current is set within the rated output current, the current capacity needs to be raised.



■ Connecting a 15 Ω resistive load

We consider a case of using a load resistance of 15 Ω. In this case, when the output current limit is set to 4 A or more, the power supply is capable of outputting voltages from 0 V to the rated maximum output voltage while in constant voltage operation mode. In this load condition, the output voltage limit is the rated maximum output voltage (for these conditions) and the output current is gradually increased from 0 A. At this time, the power supply is operating in the constant current (CC) operation mode. The power supply increases the output voltage in order to source the current setting. When the output voltage reaches the supply's maximum rated output of 60 V, no more current can be sourced to this load, regardless of the current setting.

If you wish to increase the current flow further in this condition, the unit needs to be replaced by a model having higher output voltage. Particularly for loads where a transient surge voltage is generated, the voltage must be set so that the surge voltage does not reach (or exceed) the voltage limit.

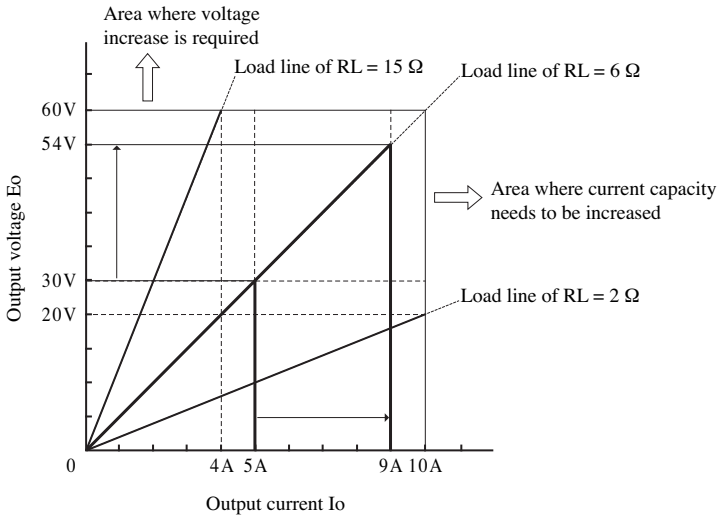

Fig.2-7 Constant Voltage Operation and Constant Current Operation

## 2.6 Output Terminal Isolation

---

- ⚠ WARNING** • Be sure to securely connect the output terminal to the chassis terminal using the short bar provided. Possible electric shock may lead to death or injury.
  - ⚠ CAUTION** • For safety reasons, even if the output terminal is grounded, make sure the insulation capacity of the output terminal (including the sensing terminal) is greater than the isolation voltage of the unit.  
If you cannot obtain a cable with sufficient rated voltage, secure adequate withstand voltage such as by passing the cable through an insulation tube with a withstand voltage greater than the isolation voltage of the unit.  
If adequate insulation measures are not taken against the isolation voltage of the unit, electric shock may occur when grounding is poor.
  - If the unit is to be remotely controlled through an external voltage source (Vext), do not ground the Vext output (leave it floating). If the Vext output is grounded in the example shown in Fig.2-9, the output is short-circuited (which can cause accidents).
- 

### ■ The output terminal is insulated

The output terminal of the power supply is insulated from the chassis. By connecting the GND wire of the power cord to the ground terminal of the switchboard, the chassis of the power supply is set to ground potential as shown in Fig.2-8.

■ When the output terminal is not grounded

The cable and load that are connected to the output terminal (including the sensor terminal) must have an insulation capacity that is greater than the isolation voltage<sup>\*1</sup> of the power supply with respect to the chassis.

In addition, cables and devices that are connected to the following pins must also have an insulation capacity that is greater than the isolation voltage of the power supply.

- Pins 1 to 19 on the control terminal board on the rear panel. This is because the above pins are at approximately the same electrical potential as the positive output terminal of the power supply.

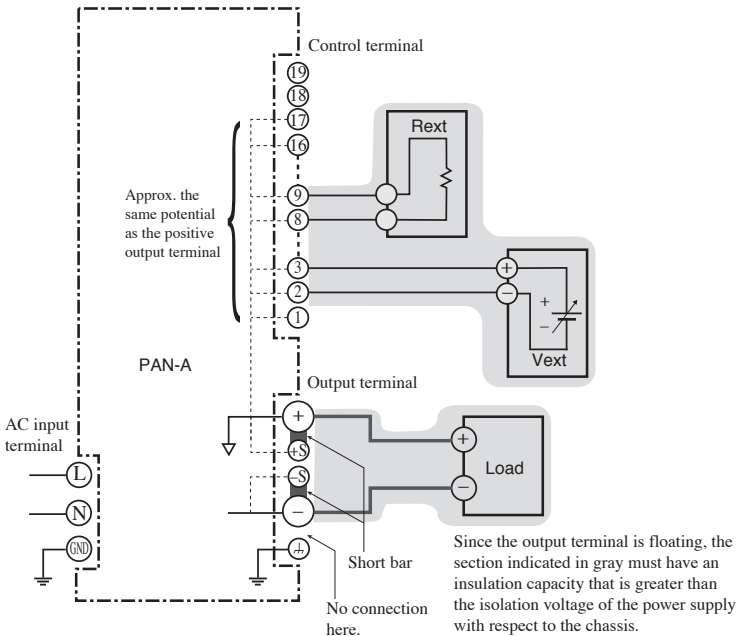

Fig.2-8 When the output terminal is not grounded

\*1. Maximum allowed voltage that appears across the output terminal of the power supply unit and the protective conductor terminal (chassis terminal).

For details on the isolation voltage of each model, see Chapter 7 "Specifications".

### ■ When the negative output terminal is connected to the chassis terminal

As shown in Fig.2-9, the negative output terminal will be at ground potential. Consequently, the cable and load that are connected to the output terminal (including the sensor terminal) must have an insulation capacity that is greater than the maximum output voltage of the power supply with respect to the chassis.

In addition, cables and devices that are connected to the following pins must also have an insulation capacity that is greater than the maximum output voltage of the power supply.

- Pins 1 to 19 on the control terminal board on the rear panel.

### ■ When the positive output terminal is connected to the chassis terminal

Since the positive output terminal will be at ground potential, the output will be negative with respect to the chassis. Cables and load that are connected to the output terminal must have an insulation capacity that is greater than the maximum output voltage of the power supply with respect to the chassis.

In addition, cables and devices that are connected to the following pins must also have an insulation capacity that is greater than the maximum output voltage of the power supply with respect to the negative output terminal.

- Pins 1 to 19 on the control terminal board on the rear panel.

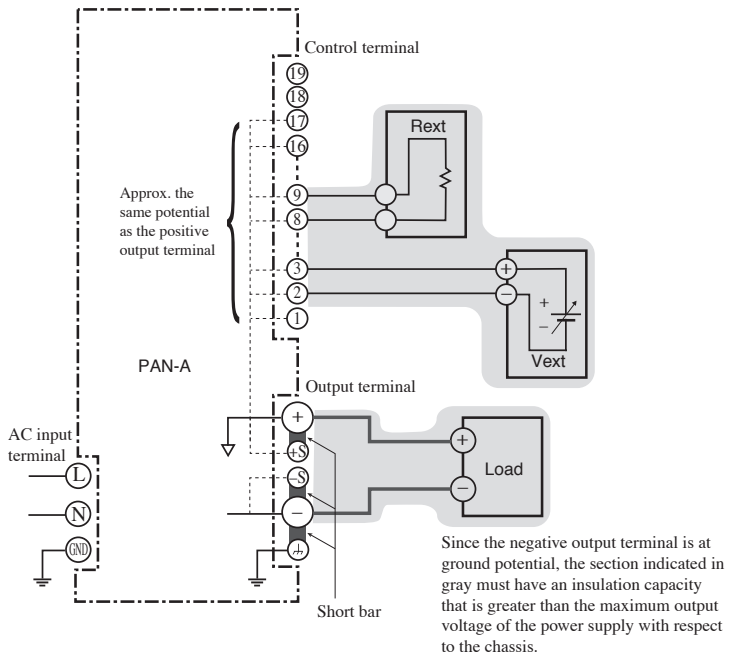

Fig.2-9 When the negative output terminal is grounded

In summary, connect either output terminal to the chassis terminal for safety reasons unless your application requires the output terminal to be floating. Moreover, the output ripple may become large if the output terminal is not connected to the chassis terminal. The specifications of the power supply assume that the negative output terminal is connected to the chassis terminal.



This chapter describes the basic operations that you can perform from the front panel.

## 3.1 Turning on the power

Before turning on the POWER switch, always check the status of the OUTPUT switch. Push in the OUTPUT switch to turn it on, and release it to turn it off.

---

**⚠ CAUTION** • If the POWER switch is turned on while the OUTPUT switch remains on, a preset voltage or current is supplied to the load.

---

**NOTE** • If the POWER switch is turned on while the OUTPUT switch remains on, AC ripple components may be superimposed at startup depending on the operation speed of the phase control circuit and the status of the load. Even when the OUTPUT switch is turned on after a power input, AC ripple components may be superimposed on the waveform at startup. This may occur if the input line has an excessively high impedance or if the input voltage is too low.

- When the remote sensing function is not being used, be sure to turn off the SENS switch. Turning on the SENS switch can cause difference between output voltage and display.

---

## Turning on the power procedure

1. Check that the POWER switch is turned off.
2. Check that the OUTPUT switch is turned off.
3. Open the front sub-panel cover of the control panel to confirm that all control switches (S1 to S5) are off.
4. Check that the SENS switch on the rear panel is off.
5. Check that the AC power code is correctly connected.
6. Turn on the switch on the switchboard which supplies power to the unit, or connect the AC power code plug to a outlet.
7. Turn on the POWER switch.  
The LED on the control panel lights up.
8. While pressing the LIMIT switch, and turn the VOLTAGE control knob; check that the output voltage can be preset in a range from zero to the rated output voltage value.
9. While pressing the LIMIT switch, and turn the CURRENT control knob; check that the output current can be preset in a range from zero to the rated output current value.

Now, the unit is ready for use.



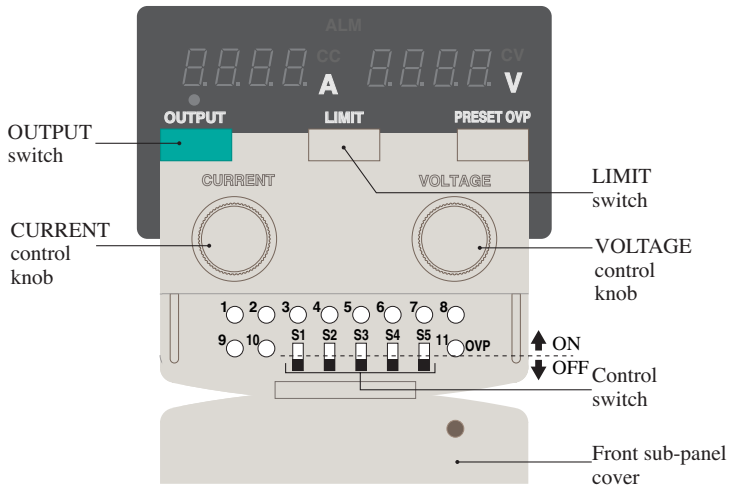

Hold the right and left edges of the sub-panel between your fingers and open the front sub-panel cover towards you.

Fig.3-1 Control panel

## 3.2 Basic operation

There are two different modes for the unit: constant voltage (CV) mode, and the constant current (CC) mode. Before starting to use the unit, determine which mode is to be employed, and select the procedure suitable for the selected operation mode.

---

**⚠ CAUTION** • To protect the load, preset the OVP trip point for either operation mode.

---

### 3.2.1 OVP(Over Voltage Protection) trip point presetting

The overvoltage protection (OVP) function protects a load from unexpectedly high voltage. If the OVP function is activated, the "ALM" (alarm) LED on the control panel lights up, and output is shut down. To release the alarm, turn off the OUTPUT switch and turn on the POWER switch again. In this case, lower the output voltage preset value. Otherwise, the OVP function is re-activated when the OUTPUT switch is turned on.

---

**⚠ CAUTION** • The OVP trip point is factory-preset to approx. 110 % of the rated output voltage of the unit. When using the unit, preset to an OVP trip point suitable for the load.

---

---

**NOTE** • To turn on the POWER switch again after OVP has been activated, wait for at least 3 seconds after cutting off the output, then turn on the POWER switch. Otherwise, the output cut-off circuit may remain latched, disabling the output.

- If the OVP function is activated, the 700W models turn off the POWER switch when output is shut down.

---

## Presetting the OVP trip point

---

**⚠ CAUTION** • After presetting the OVP trip point, be sure to check that the OVP function works at the preset voltage (Procedure 4 to 6). For checking, it is necessary to output an actual voltage. Therefore, first check that no load is connected, and proceed with the following procedure.

---

1. Turn off the OUTPUT switch.
2. Turn on the POWER switch.
3. While presetting the PRESET OVP switch, turn the OVP variable resistor with a Phillips-head screwdriver, and preset to the over voltage against which the load is to be protected.
4. Turn the VOLTAGE control knob fully counter-clockwise.
5. Turn on the OUTPUT switch.
6. Gradually turn the VOLTAGE control knob clockwise, and check that the "ALM" (alarm) LED lights up and the output is shut down when the output voltage has reached the preset OVP voltage.
7. Turn the VOLTAGE control knob fully counter-clockwise again.
8. Turn off the OUTPUT switch.
9. Turn off the POWER switch. (175W, 350W only)

Now, the OVP trip point presetting is completed.

### 3.2.2 Using as a constant voltage power supply

---

**⚠ WARNING** • For safety, turn off the POWER switch when connecting the load.

---

1. Check that the OUTPUT switch is turned off.
2. Turn on the POWER switch.
3. While pressing the LIMIT switch, preset the requested current by turning the CURRENT control knob.

---

**NOTE** • The LIMIT switch simply displays the present voltage and current settings. It has no memory feature.

---

4. While pressing the LIMIT switch, preset the requested voltage by turning the VOLTAGE control knob.
5. Turn on the OUTPUT switch.

The "CV" LED lights up on the control panel to indicate that the unit is in constant voltage mode.

---

**⚠ CAUTION** • For the loads listed below in which sudden voltage application is undesirable, follow procedure 1 to 3 above, then follow procedure 4 to 6 below.

- a. Loads of unknown resistance
- b. Loads whose resistance varies over a wide range
- c. Loads of large inductance

---

4. Turn the VOLTAGE control knob fully counter-clockwise.
5. Turn on the OUTPUT switch.
6. Turn the VOLTAGE control knob slowly to raise voltage gradually.

The "CV" LED lights up on the control panel to indicate that the unit is in constant voltage mode.

### 3.2.3 Using as a constant current power supply

---

**⚠ WARNING** • For safety, turn off the POWER switch when connecting the load.

---

1. Check that the OUTPUT switch is turned off.
2. Turn on the POWER switch.
3. While pressing the LIMIT switch, preset the requested voltage by turning the VOLTAGE control knob.

---

**NOTE** • The LIMIT switch simply displays the present voltage and current settings. It has no memory feature.

---

4. While pressing the LIMIT switch, preset the requested current by turning the CURRENT control knob.
5. Turn on the OUTPUT switch.

If a load is connected, the "CC" LED lights up on the control panel showing that the unit is in constant current mode.

---

**NOTE** • If no load is connected, or if the load current level is too low, the unit shifts to constant voltage mode, the "CV" LED lights up. For more information, see "2.5 CV power supply and CC power supply".

---

---

**⚠ CAUTION** • For the loads listed below in which sudden current application is undesirable, follow procedure 1 to 3 above, then follow procedure 4 to 6 below.

- a. Loads of unknown resistance
- b. Loads whose resistance varies over a wide range
- c. Loads of large inductance

---

4. Turn the CURRENT control knob fully counter-clockwise.
5. Turn on the OUTPUT switch.
6. Turn the CURRENT control knob slowly to increase current gradually.

The "CC" LED lights up on the control panel to indicate that the unit is in constant current mode.

### 3.3 Connecting load

---

**NOTE**

- The output terminals of this unit are found in two locations, on the rear panel and the front panel. The terminals on the front panel, however, are for auxiliary purposes and may not satisfy the specified performance.
  - Usually, connect the chassis ground terminal ( $\perp$ ) on the front panel to a - (neg.) output terminal or + (pos.) output terminal using the shorting bar.
- 

#### Current capacity of load cables

Load cables must be rated to carry the maximum rated output current of the unit. If their current rating exceeds the maximum rated output current, they will carry the maximum current even if a load is short circuited. The allowable current of a wire is determined by the maximum allowable temperature of the cable insulation, which in turn is governed by a current-caused resistance loss, ambient temperature, and thermal resistance to the outside. The allowable currents in Table 3-1 show the capacity of current flowing through a heat-resistant PVC wire (single wire) having a maximum allowable temperature of 60 °C when the wire is stretched horizontally in the air at an ambient temperature of 30 °C. If the condition is such that PVC wires with lower heat-resistant temperature are used, ambient temperature reaches more than 30 °C, or the wires are bundled, resulting in low heat radiation, the current capacity needs to be reduced.

Based on this consideration, it is better to make heat radiation as great as possible to let a larger current flow, as long as wires having the same heat-resistant temperature are used. For measures against noise in the load cables, installing the + (pos.) and - (neg.) output lines side by side or bundling them together is more effective against unnecessary noise. The Kikusui-recommended currents shown in Table 3-1 are allowable current values that have been reduced in consideration of potential bundling of load cables. Use these values as a guideline when installing load wires.

Because wires have resistance, voltage drop in wires becomes greater as the wire becomes longer or the current becomes larger. This causes the voltage applied at the load end to be smaller.

The PAN-A series power supplies have a sensing function that compensates for this voltage drop. Compensation of up to approximately

0.6 V is available for a single line. If voltage drop exceeds this level, wires having a greater sectional area should be used.

Table 3-1 Nominal Cross-sectional Areas of Cables and Allowable Currents

Nominal cross-sectional area [mm <sup>2</sup> ]	AWG	(Reference cross-sectional area) [mm <sup>2</sup> ]	Allowable current*1 [A] (Ta = 30 °C)	Current recommended by Kikusui [A]
0.9	18	(0.82)	17	4
1.25	16	(1.31)	19	6
2	14	(2.08)	27	10
3.5	12	(3.31)	37	-
5.5	10	(5.26)	49	20
8	8	(8.37)	61	30
14	5	(13.3)	88	50
22	3	(21.15)	115	80
30	2	(33.62)	139	-
38	1	(42.41)	162	100
50	1/0	(53.49)	190	-
60	2/0	(67.43)	217	-
80	3/0	(85.01)	257	200
100	4/0	(107.2)	298	-
125	-	-	344	-
150	-	-	395	300
200	-	-	469	-

\*1. Excerpts from Japanese laws related electrical equipment

### Withstand voltage of load cables

For load cables, use cable with a higher voltage rating than the isolation voltage of a PAN-A series power supply. In particular, if the rated voltage of load cables is lower than the isolation voltage of the power supply having a rated output voltage of 40 V or more, electric shock may be caused.

When using the unit as a floating power supply with the isolation voltage exceeding 70 V, use the double insulation type of load cable concerning damage to the covering material of cable or any possible condition of failure, and securely attach the output terminal cover on the output terminals.

## Using the auxiliary output terminals on the front panel

- 
- ⚠ WARNING** • For safety, turn off the POWER switch when connecting the load.
- After connecting the load cable, mount the auxiliary output terminal cover. To mount the auxiliary output terminal cover, see "3.4 Mounting the auxiliary output terminal cover".
- ⚠ CAUTION** • To assure a good connection of the load cable to the output terminals, use crimped terminals.
- 

When the length of load cable connected between the power supply and the load becomes longer, an external noise may be affected easily. In such cases, use the shielded type of load cable as well as for the sensing cable. As for the load cable and the sensing cable, connect the shielded conductor portion of the cable to the chassis ground terminal on the front panel, and for the remote control cable, connect the shielded conductor portion of the cable to the Protective conductor terminal on the rear panel.

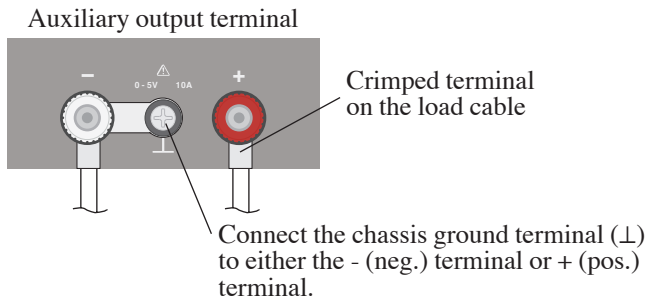

Fig.3-2 Connection to the auxiliary output terminals on the front panel



## Using the OUTPUT terminal board on the rear panel

- ⚠ WARNING** • For safety, turn off the POWER switch when connecting the load.
- After connecting the load cable, mount the rear output terminal cover.
- ⚠ CAUTION** • To assure a good connection of the load cable to the output terminals, use crimped terminals.

When the length of load cable connected between the power supply and the load becomes longer, an external noise may be affected easily. In such cases, use the shielded type of load cable as well as for the sensing cable. As for the load cable and the sensing cable, connect the shielded conductor portion of the cable to the chassis ground terminal on the front panel, and for the remote control cable, connect the shielded conductor portion of the cable to the Protective conductor terminal on the rear panel.

For the model 175W user, see Fig.3-3.

For the model 350W, or 700W user, see Fig.3-4.

### MODEL 175W

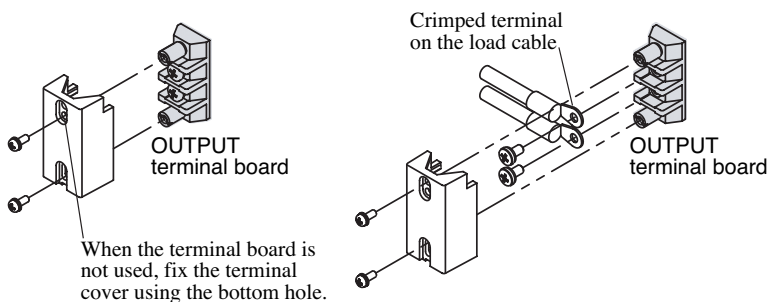

Fig.3-3 Connection to the OUTPUT terminal board on the rear panel (model 175W)

As shown in Fig.3-3, lay load cables at the left of the OUTPUT terminal board, as seen from the rear panel.

## MODEL 350W/700W

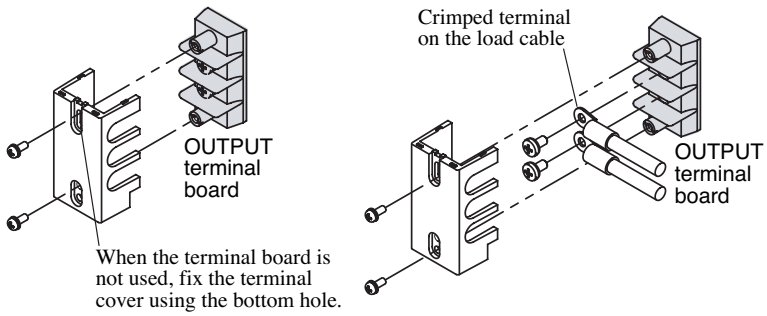

Fig.3-4 Connection to the OUTPUT terminal board on the rear panel (model 350W/700W)

As shown in Fig.3-4, lay load cables at the right of the OUTPUT terminal board, as seen from the rear panel.

### 3.4 Mounting the auxiliary output terminal cover

The unit is provided with a front auxiliary output terminal cover. Mount the cover when the unit is to be used.

---

**⚠ WARNING** • The output electrode on the auxiliary output terminal is uncovered. To prevent electric shock, always install an auxiliary output terminal cover on the terminal, even if the terminal is not in use.

**⚠ CAUTION** • To mount the cover, be sure to use the screws supplied. Other screws, if of an incorrect length, may contact some internal part of the unit.

---

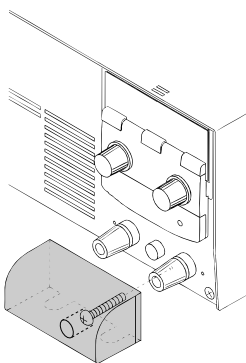

Fig.3-5 Mounting the auxiliary output terminal cover

## 3.5 Fixing output presetting

The unit includes VOLTAGE and CURRENT control knobs; in order to make them mechanically fixed or semi-fixed, guard caps are supplied with the unit. Use them if output presetting is seldom necessary.

### Using the guard caps

1. Check that the OUTPUT switch is turned off.
2. Turn on the POWER switch.
3. While pressing the LIMIT switch, preset the output level (voltage and/or current) to a desired value. Here, a rough presetting is acceptable.
4. Pull out the VOLTAGE and/or CURRENT control knob(s) without turning it.
5. While pressing the LIMIT switch, use a flat-head screwdriver, and preset the output to a desired value.

#### ■ To fix presetting

6. Push in the guard cap, instead of the removed knob.
7. Press the LIMIT switch again to confirm the presetting is not changed.

#### ■ To semi-fix presetting

6. As shown in Fig.3-6, pierce the guard cap top with a Phillips-head screwdriver.
7. Push in the guard cap, instead of the removed knob.  
Since the guard cap is pierced, the output level may be readjusted using a flat-head screwdriver.

---

**NOTE**

- If you intend to re-install the knob, keep it in a safe place. There is a metal fitting inside the knob's bushing that engages with the axis of a variable resistor (see Fig.3-7). Even when you remove a knob, this metal fitting does not usually come off the knob. However, if it does come off, place it inside the knob's bushing.
-

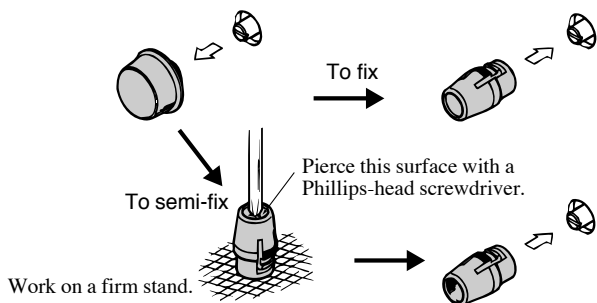

Fig.3-6 Mounting the guard cap

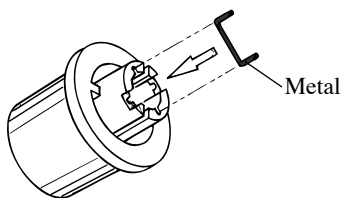

Fig.3-7 Metal Fitting inside the Bushing

## Re-mounting the control knob

There is a slot on the end of the shaft of the output preset variable resistor. Mount the knob so that it engages the slot to prevent the knob from turning freely. Follow the procedure described below.

1. Check that there is a metal fitting inside the knob's bushing.
2. Remove the guard cap pressing the two locking mechanisms.
3. Press in the knob till it softly touches the shaft of the variable resistor.
4. Using gentle force, turn the knob fully counter-clockwise.
5. Pressing the knob, turn it further counter-clockwise until it settles in deeply, and the knob and shaft are engaged.

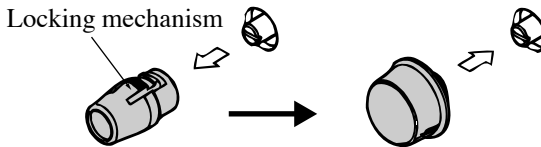

Fig.3-8 Removing the guard cap

Use of the CONTROL terminal board on the rear panel allows the unit to perform remote sensing, external output control, parallel operation, and series operation.

**WARNING**

- To avoid electric shock, for remote sensing lines and control lines, use wires with a rated voltage higher than the isolation voltage of the unit. If you cannot obtain such wires, protect the wires by using insulation tubes with a withstand voltage higher than the isolation voltage of the unit.
- When using the unit as a floating power supply with the isolation voltage exceeding 70 V, use the double insulation type of load cable concerning damage to the covering material of cable or any possible condition of failure, and securely attach the output terminal cover on the output terminals.

## 4.1 CONTROL terminal board

This section describes the procedure for connecting wires, and precautions when using the CONTROL terminal board.

### ■ Wires and tools required for connection

#### 1. Wires

As shown in Fig.4-1, the CONTROL terminal board has two types of terminals, which use different wires.

Group A (No. 2 to 19 terminals)

Single wire:  $\phi 0.32$  to  $\phi 0.65$  (AWG28 to AWG22)

Twisted wire:  $0.08 \text{ mm}^2$  to  $0.32 \text{ mm}^2$  (AWG28 to AWG22)

Group B (-S, +S, and No. 1 terminal)

Single wire:  $\phi 0.4$  to  $\phi 1.2$  (AWG26 to AWG16)

Twisted wire:  $0.3 \text{ mm}^2$  to  $1.25 \text{ mm}^2$  (AWG22 to AWG16)  
(Bare wire diameter:  $\phi 0.18$  or more)

## 2.Screwdriver











Axis diameter:  $\phi 3$

End width: 2.6 mm

## 3. Wire stripper

One suitable for the wires described above

Table 4-1 Alignment on CONTROL terminal board

Expression on the		Signal name	Description	Expression on the CAUTION label
No.	panel			
19	19	NC	No connection	19 NC
18	•	NC	No connection	18 NC
17	•	MASTER OUT	Master unit output for master-slave control parallel connection	17 MASTER OUT
16	•	MASTER COM	Master unit common line for master-slave control parallel connection	16 MASTER COM
15	•	SLAVE IN 1	Slave unit input for master-slave control parallel connection	15 SLAVE 1
14	14	SLAVE COM 1	Slave unit common line for master-slave control parallel connection	14 COM (SLAVE 1)
13	13	SLAVE IN 2	Slave unit output for master-slave control parallel connection	13 SLAVE 2
12	•	SLAVE COM 2	Slave unit common line for master-slave control parallel connection	12 COM (SLAVE 2)
11	•	OUTPUT ON/OFF	Output ON/OFF control	11  OUT ON/OFF
10	•	A COM <sup>*1</sup>	Common line for internal control circuit	10 
9	•	CC R CONT IN	Input for output current control using external resistor	9  CC-R
8	8	CC R CONT OUT	Output for output current control using external resistor	8  CC-R
7	7	CC V CONT	Input for output current control using external voltage	7  CC-V
6	•	A COM <sup>*1</sup>	Common line for internal control circuit	6  CC-V
5	•	CV R CONT IN	Input for output voltage control using external resistor	5  CV-R
4	•	CV R CONT OUT	Output for output voltage control using external resistor	4  CV-R
3	•	CV V CONT	Input for output voltage control using external voltage	3  CV-V
2	2	A COM <sup>*1</sup>	Common line for internal control circuit	2  CV-V



1	1	SERIES SIG OUT	Signal output for master-slave control series connection	1 SERIES SIG
+S	+S	SENSING +	Positive input for remote sensing	—
-S	-S	SENSING -	Negative input for remote sensing	—

\*1. A COM is connected to the + (pos.) terminal inside.

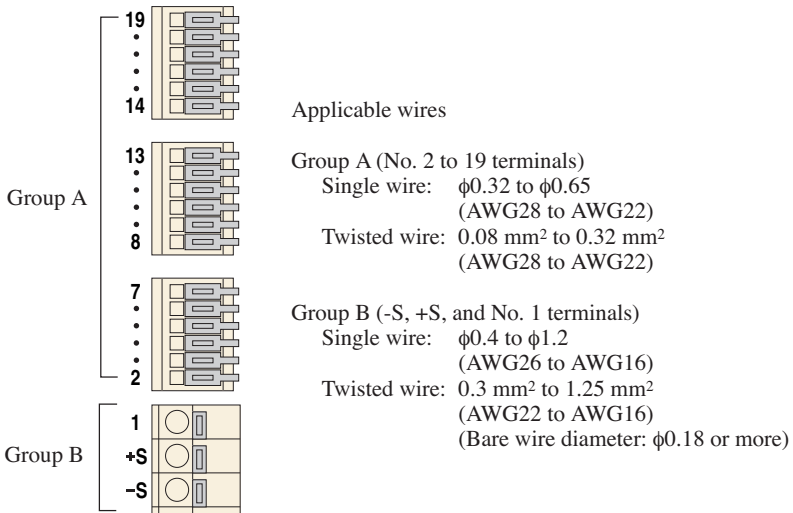

Fig.4-1 CONTROL terminal board

## Connecting procedure



**WARNING** • Never attempt to connect wires to the control terminals while the POWER switch turned on. This may result in electric shock or damage to the internal circuitry.

1. Turn off the OUTPUT switch.
2. Turn off the POWER switch.
3. Use a wire stripper to remove the covering from wires.

Remove the covering from each wire over a distance of 7 mm to 10 mm (9 mm is recommended). Use of the strip gauge on the top or rear panel of the unit, or that shown in Fig.4-2, allows you to remove the required amount of covering from a wire.

4. Insert wires into control terminals as shown in Fig.4-2

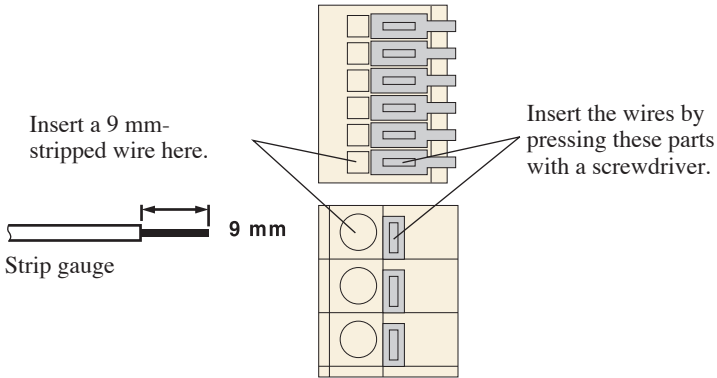

Fig.4-2 Connection to the control terminals



**WARNING** • The potential of the control terminals is nearly the same as that of the + (pos.) output terminals of the unit. If part of the wire extending off a control terminal makes contact with the chassis, electric shock or internal circuit breakage may be caused. Insert wires into the terminals in such a way that bare parts are not exposed.



Fig.4-3 Connecting precautions

5. Remove the screwdriver from the terminal, and pull the wire gently to ensure that it is securely inserted.

## 4.2 Remote sensing

The remote sensing function is intended to reduce the influence of voltage drops affected by the load cable resistance, to keep the output voltage stable at the load terminal. To perform remote sensing, an electrolytic capacitor that has good frequency characteristics is needed at the sensing point (load terminal).

- 
- NOTE** • The maximum output voltage of the 16 V line models is 16.8 V. Thus, meeting the compensation voltage of the remote sensing (0.6 V for a single line) causes the unit not to secure the rated voltage. In this case, use load cables having a larger sectional area to limit the voltage drop (up to the load end) to 0.4 V or less for a single line.
- 

### Connecting procedure

- 
- WARNING** • Never attempt to connect wires to the control terminals while the POWER switch turned on. This may result in electric shock or damage to the internal circuitry.
- 

1. Turn off the OUTPUT switch.
2. Turn off the POWER switch.
3. As shown in Fig.4-4, connect the +S terminal and the + (pos.) terminal of the load, and connect the -S terminal and the - (neg.) terminal of the load.

- 
- NOTE** • To decrease output ripple voltages resulting from inductive effects, use a shielded wire or a twisted-pair wire. Make sure the shielded wire has a withstand voltage of 120 % or more of the unit's rated output voltage.
- Connect the shield to the chassis ground terminal.
-

**⚠ WARNING**

• For sensing wires, use wires with a higher voltage rating than the isolation voltage of the unit. For details, see "2.6 Output Terminal Isolation".

**⚠ CAUTION**

• To turn on/off the power supplied to a load using a mechanical switch, provide additional switches between the sensing wires as shown in Fig.4-5; turn on/off the power and remote sensing function simultaneously. In addition, make sure the OUTPUT switch or POWER switch turned off when turning on/off the mechanical switch.

• If the sensing wires come loose, the output voltage across the load cannot be stabilized and may cause excessive voltage to be applied to the load. Securely connect the sensing wires.

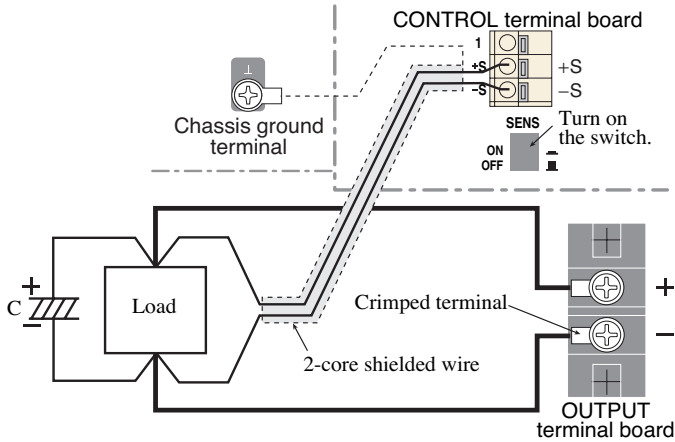

Fig.4-4 Remote sensing connection

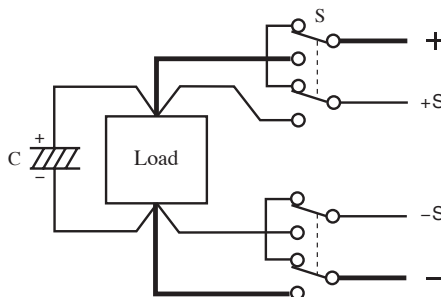

Fig.4-5 Power ON/OFF using mechanical switches

4. Connect an electrolytic capacitor (C) with a capacity of a few thousands of  $\mu\text{F}$  to a few tens of thousands of  $\mu\text{F}$  across the load terminals.

---

**⚠ CAUTION** • Use a capacitor (C) whose withstand voltage is 120 % or more of the unit's rated voltage.

---

- NOTE**
- If the length of wiring to a load extends to 3 m or more, the phase shift caused by the inductance and capacitance of the wiring becomes non-negligible, thereby causing oscillation. In such cases, the capacitor (C) prevents oscillation.
  - If the load current changes suddenly to pulse form, the output voltage may increase due to effects from the inductance components of the wiring. In such cases, the capacitor (C) also prevents variations in output.
  - In addition, twisting the load wires reduces the inductance component, thereby stabilizing the output.
- 

5. Check again that all the cables and wires are connected correctly.
6. Turn on the sensing switch.

To turn the sensing switch (SENS) ON/OFF, push the switch to the inside than the panel surface with a not sharp pointed stick such as a flat-blade screwdriver.

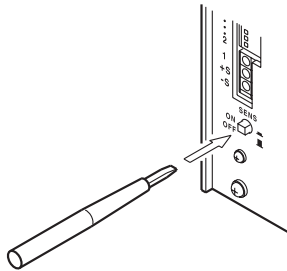

Fig.4-6 Changing the sensing switch (SENS)

- 
- ⚠ CAUTION** • After using the remote sensing, remove the sensing wire, and be sure to turn off the SENS switch.
- Do not turn on/off the SENS switch while the POWER switch is on.
-

## 4.3 Analog remote control

It is possible to remotely control the unit's output voltage and current using analog signals. Output ON/OFF operation by means of external contact points is also possible.

The above-mentioned remote of controls can be used in combination, but note the following exceptions.

- Combination of output voltage control using external resistor and output voltage control using external voltage.
- Combination of output current control using external resistor and output current control using external voltage.



**WARNING** • Incorrect handling of the CONTROL terminal board may cause electric shock or accidents due to short circuit of the output. When using remote control, always follow the procedures for each corresponding control method.

- The common line for the internal control circuit of the unit is connected to the + (pos.) output terminal inside. Therefore, the potential of the common terminal of the CONTROL terminal board, resistors, voltage source and switch to be connected to the CONTROL terminal board are nearly the same as that of the + (pos.) output terminal.

These parts should be protected using insulation materials with a withstand voltage higher than the isolation voltage of the unit, to prevent electric shock.

---

## ■ Before performing analog remote control

The unit is factory-adjusted for control from the front panel (i.e., local control). Before using remote control (excluding output ON/OFF using external contact points), re-adjustment is necessary. Re-adjustment is also necessary when changing from remote control back to local control. For details on calibration, see section "6.3 Adjustment".

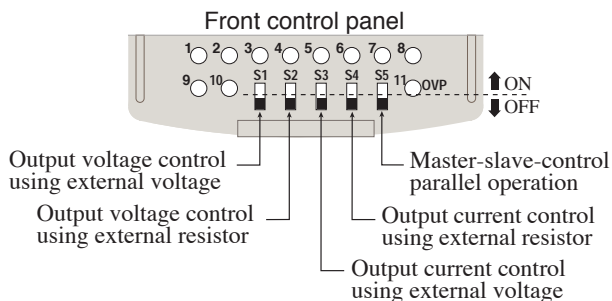

Fig.4-7 Alignment of control switches

### 4.3.1 Controlling output voltage with external resistor

This method is used to control output voltage using a  $0 \Omega$  to approx.  $10 \text{ k}\Omega$  external resistor.

- 
- ⚠ WARNING**
- The insulation of the external resistance ( $R_{ext}$ ) and the cable connecting to it should be greater than the isolation voltage of the unit. For details on the isolation voltage of each model, see Chapter 7 "Specifications".
  - Never attempt to carry out wiring to the control terminals with the POWER switch turned ON. Otherwise, electric shock or failure of the internal circuit may be caused.
- 

#### Connection and setup procedure

1. Turn off the OUTPUT switch.
2. Turn off the POWER switch.
3. Set the control switches S1 and S2 as shown in Fig.4-8.
4. Connect an external resistor across the control terminals [4] and [5] as shown in Fig.4-8.

- 
- ⚠ CAUTION**
- If  $R_{ext}$  is disconnected, excessive voltage may be applied to a load. Connect the  $R_{ext}$  to the control terminals firmly.
  - To use  $R_{ext}$  which consists of a multiple number of fixed resistors and a switch, and select one of them for control, use a short circuit type or continuous type switch.
-



**NOTE**

- To minimize the influence of noise on the output, use a 2-core shielded wire or a twisted-pair wire to connect the control terminals and Rext. If using a shielded wire, connect the shield to the chassis ground terminal.
- Approx. 1 mA of current always flows in Rext. For Rext, use a 1/2 W or larger metal film or wire-wound type resistor with a good temperature coefficient and small aging effect.

5. Re-check that the connections on the terminal board and the switch settings are correct.

Before controlling output voltage using the external resistor, re-adjust the voltage system of the unit. For the adjustment procedure, see "6.3 Adjustment".

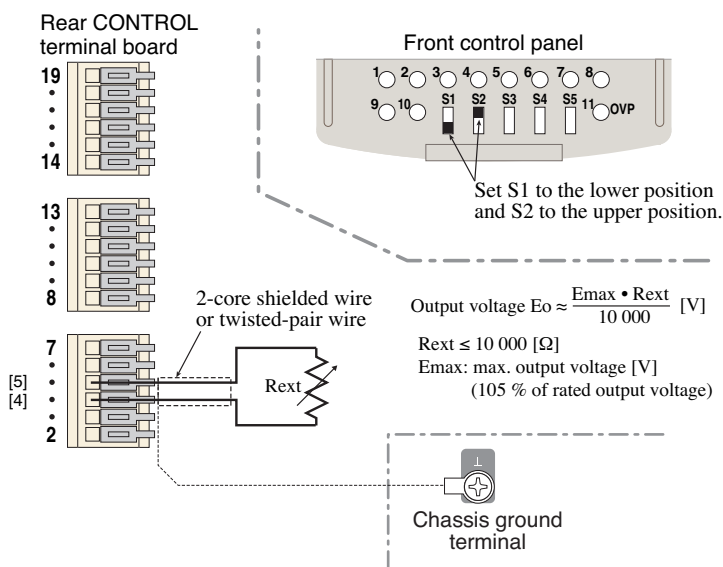

Fig.4-8 Connection and setup for output voltage control using external resistor

### 4.3.2 Controlling output voltage with external voltage

This method is used to control output voltage using 0 V to approx. 10 V.

---

**⚠ WARNING**

- The insulation of the external voltage source (Vext) and the cable connecting to it should be greater than the isolation voltage of the unit. For details on the isolation voltage of each model, see Chapter 7 "Specifications". In addition, leave the output of the external voltage source (Vext) floating. For details, see "2.6 Output Terminal Isolation".
  - Never attempt to carry out wiring to the control terminals with the POWER switch turned ON. Otherwise, electric shock or failure of the internal circuit may be caused, and may result in improper operations.
- 

---

**NOTE**

- When controlling the unit using an external voltage source which has a quick rising time relative to the capacitive load, the phase control circuit of the unit cannot respond to the external voltage, which may cause AC components to be superimposed on the rising waveform.
- 

#### Connection and setup procedure

1. Turn off the OUTPUT switch.
  2. Turn off the POWER switch.
  3. Turn the VOLTAGE control knob fully clockwise.
- 

**NOTE**

- For output voltage control with an external voltage, you can use the VOLTAGE control knob to adjust the ratio of the output voltage to the input voltage from the external voltage source (Vext). (See Fig.4-9.)  
Therefore, keep the control knob turned fully clockwise so that output voltage can be remotely controlled, up to the rated output voltage. If output preset on the panel needs to be fixed, use the supplied guard cap.
-

4. Set the control switches S1 and S2 to the position shown in Fig.4-9.
5. Connect the voltage source across the control terminals [2] and [3] as shown in Fig.4-9.

---

**⚠ CAUTION** • Watch the polarity of Vext. Connection at incorrect polarity may damage the unit.

- If Vext is disconnected, an unexpected voltage may be supplied by external noise. Connect the Vext to the control terminals firmly.
- Do not apply a voltage of 10.5 V or more, or reverse the voltage between control terminals [2] and [3]. Otherwise, the unit may be damaged.

---

**NOTE** • To minimize the influence of noise on the output, use a 2-core shielded wire or a twisted-pair wire to connect the control terminals and Vext. If using a shielded wire, connect the shield to the chassis ground terminal.

- The input impedance across the control terminals [2] and [3] is approx. 10 k $\Omega$ .
- For Vext, use a voltage source of low noise and good stability. Noise in Vext is multiplied by the amplification degree of the unit and appears in the unit's output. Thus, output ripple noise may not meet the unit's specifications.

---

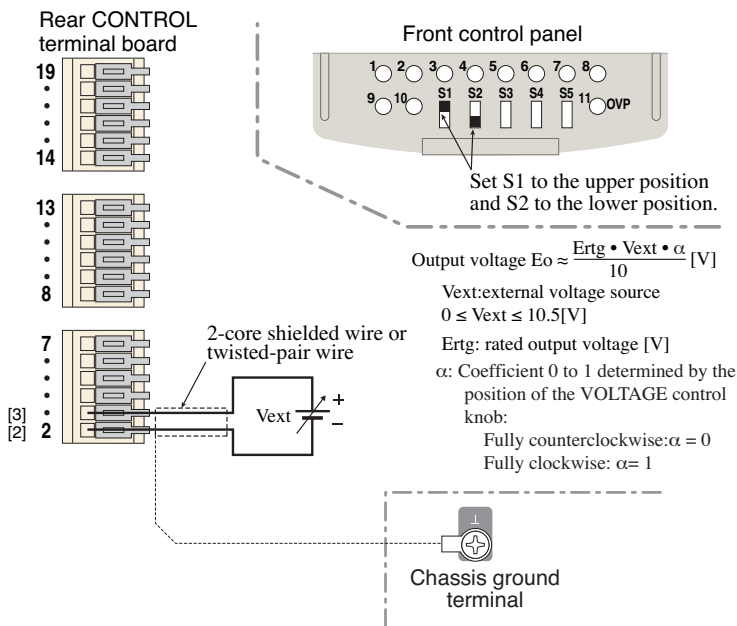

Fig.4-9 Connection and setup for output voltage control using external voltage

6. Re-check that the connections on the terminal board and the switch settings are correct.

Before controlling output voltage using the external voltage, re-adjust the voltage system of the unit. For the adjustment procedure, see "6.3 Adjustment".

## ■ When you wish to connect the shield to Vext

When using shielded wires, some external voltage sources may require that the shield be connected to the external voltage source. In such cases, the grounding method used for the external voltage source (Vext) and the unit creates a condition where the output is short-circuited, as shown in Fig.4-10. Thus, do not connect the shield to the chassis ground terminal of the unit.

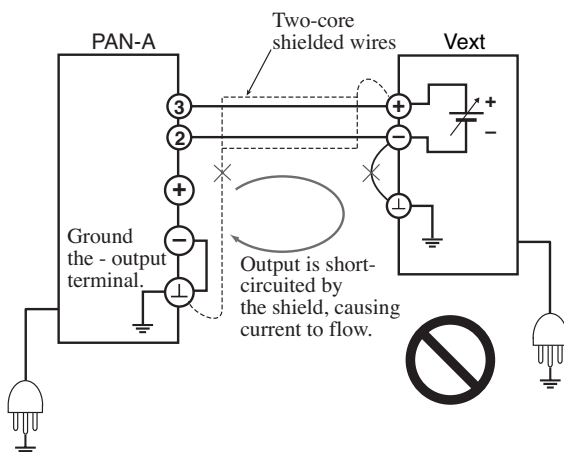

Fig.4-10 A connection where output is short-circuited by the shield

**⚠ WARNING** • Do not ground the output of the external voltage source (Vext) — float it instead. The potential of control terminals [2] and [3] are nearly the same as that of the unit's + (pos.) output terminal, and short-circuit currents are provided to the signal line without a shield.

### 4.3.3 Controlling output current with external resistor

This method is used to control output current using a 0  $\Omega$  to approx. 10 k $\Omega$  external resistor.

- 
- ⚠ WARNING**
- The insulation of the external resistance ( $R_{ext}$ ) and the cable connecting to it should be greater than the isolation voltage of the unit. For details on the isolation voltage of each model, see Chapter 7 "Specifications".
  - Never attempt to carry out wiring to the control terminals with the POWER switch turned ON. Otherwise, electric shock or failure of the internal circuit may be caused, and may result in improper operations.
- 

#### Connection and setup procedure

1. Turn off the OUTPUT switch.
2. Turn off the POWER switch.
3. Set the control switches S3 and S4 to the position as shown in Fig.4-11.
4. Connect an external resistor across the control terminals [8] and [9] as shown in Fig.4-11.

- 
- ⚠ CAUTION**
- If  $R_{ext}$  is disconnected, the internal overcurrent-protection circuit will be activated, causing the "ALM" LED to light up. However, current exceeding the rating will be output until this circuit functions. Thus, connect  $R_{ext}$  to the control terminals securely.
  - To use  $R_{ext}$  which consists of a multiple number of fixed resistors and a switch, and select one of them for control, use a short circuit type or continuous type switch.
-

**NOTE**

- To minimize the influence of noise on the output, use a 2-core shielded wire or a twisted-pair wire to connect the control terminals and Rext. If using a shielded wire, connect the shield to the chassis ground terminal.
- Approx. 0.4 mA of current always flows in Rext. For Rext, use a 1/2 W or larger metal film or wire-wound type resistor with a good temperature coefficient and small aging effect.

5. Re-check that the connections on the terminal board and the switch settings are correct.

Before controlling output current using the external resistor, re-adjust the current system of the unit. For the adjustment procedure, see "6.3 Adjustment".

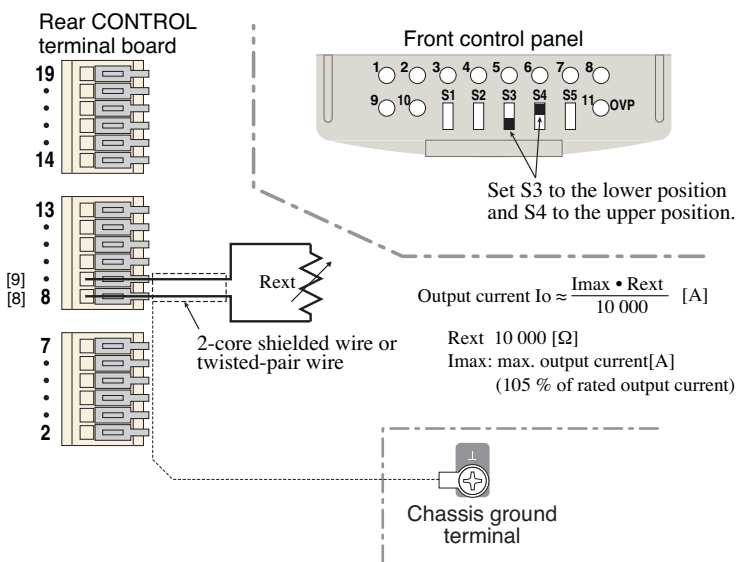

Fig.4-11 Connection and setup for output current control using external resistor

### 4.3.4 Controlling output current with external voltage

This method is used to control output current using 0 V to approx. 10 V external voltage.

---

**⚠ WARNING** • The insulation of the external voltage source ( $V_{ext}$ ) and the cable connecting it should be greater than the isolation voltage of the unit. For details on the isolation voltage of each model, see Chapter 7 "Specifications".

In addition, leave the output of the external voltage source ( $V_{ext}$ ) floating. For details, see "2.6 Output Terminal Isolation".

- Never attempt to carry out wiring to the control terminals with the POWER switch turned ON. Otherwise, electric shock or failure of the internal circuit may be caused, and may result in improper operations.

---

**NOTE** • When controlling the unit using an external voltage source which has a quick rising time relative to the capacitive load, the phase control circuit of the unit cannot respond to the external voltage, which may cause AC components to be superimposed on the rising waveform.

---

#### Connection and setup procedure

1. Turn off the OUTPUT switch.
2. Turn off the POWER switch.
3. Turn the CURRENT control knob fully clockwise.

---

**NOTE** • For output current control with an external voltage, you can use the current CURRENT control knob to adjust the ratio of the output current to the input voltage from the external voltage source ( $V_{ext}$ ). (See Fig.4-12.)

Therefore, keep the control knob turned fully clockwise so that output current can be remotely controlled, up to the rated output current. If the output preset on the panel needs to be fixed, use the supplied guard cap.

---



4. Set the control switches S3 and S4 to the position as shown in Fig.4-12.
5. Connect the voltage source across the control terminals [6] and [7] as shown in Fig.4-12.

---

**⚠ CAUTION** • Watch the polarity of the external voltage source (Vext). Connection at an incorrect polarity may damage the unit.

- If Vext is disconnected, an unexpected voltage may be supplied by external noise. Connect the Vext to the control terminals firmly.
- Do not apply a voltage of 10.5 V or more, or reverse the voltage between control terminals [6] and [7]. Otherwise, the unit may be damaged.

---

**NOTE** • To minimize the influence of noise on the output, use a 2-core shielded wire or a twisted-pair wire to connect the control terminals and Vext. If using a shielded wire, connect the shield to the chassis ground terminal.

- The input impedance across the control terminals [6] and [7] is approx. 25 k $\Omega$ .
- For Vext, use a voltage source of low noise and good stability. Noise in Vext is multiplied by the amplification degree of the unit and appears in the unit's output. Thus, output ripple noise may not meet the unit's specifications.

---

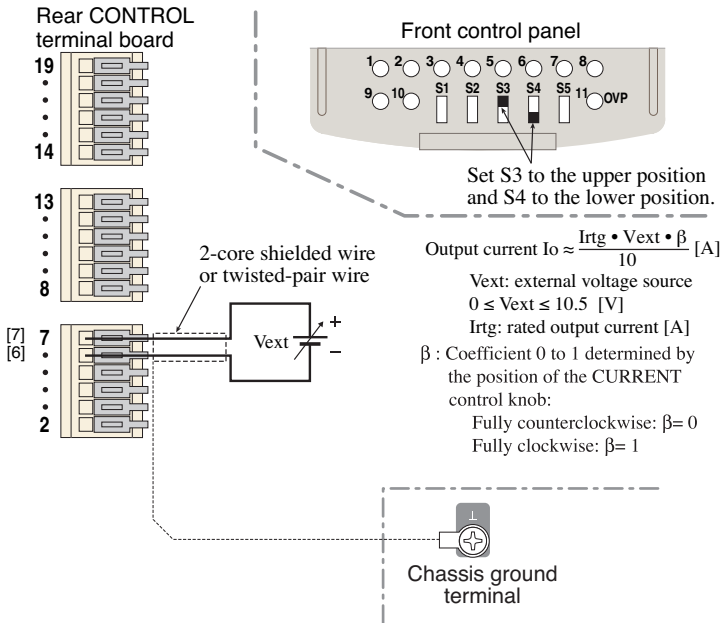

Fig.4-12 Connection and setup for output current control using external voltage

6. Re-check that the connections on the terminal board and the switch settings are correct.

Before controlling output current using the external voltage, re-adjust the current system of the unit. For the adjustment procedure, see "6.3 Adjustment".

## ■ When you wish to connect the shield to Vext

When using shielded wires, some external voltage sources may require that the shield be connected to the external voltage source. In such cases, the grounding method used for the external voltage source (Vext) and the unit creates a condition where the output is short-circuited, as shown in Fig.4-13. Thus, do not connect the shield to the chassis ground terminal of the unit.

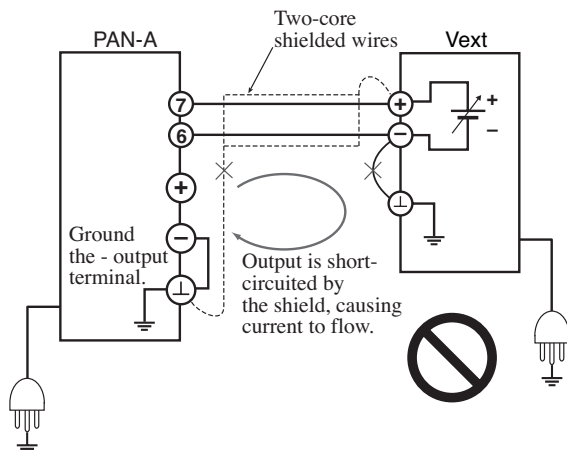

Fig.4-13 A connection where output is short-circuited by the shield



**WARNING** • Leave the output of the external voltage source (Vext) floating. The potential of control terminals [6] and [7] are nearly the same as that of the unit's + (pos.) output terminal, and short-circuit currents are provided to the signal line without a shield.

### 4.3.5 Output ON/OFF control

This method is used to control the output's ON/OFF status using external contact points. Output is turned off when the external contact points are closed.

---

**⚠ WARNING** • The insulation of the external contact (S) and the cable connecting it should be greater than the isolation voltage of the unit. For details on the isolation voltage of each model, see Chapter 7 "Specifications".

- Never attempt to carry out wiring to the control terminals with the POWER switch turned ON. Otherwise, electric shock or failure of the internal circuit may be caused, and may result in improper operations.

**⚠ CAUTION** • A negative voltage of approx. 0.6 V is generated when the output is turned off, and a reverse current of a few tens of mA may flow.

---

**NOTE** • In output of ON/OFF, "OFF" has higher priority. Therefore, always set the OUTPUT switch to ON so that ON/OFF control using external contact points can be performed.

---

#### Connection and setup procedure

1. Turn off the OUTPUT switch.
2. Turn off the POWER switch.
3. Connect the contact points S (switch) across the control terminals [10] and [11] as shown in Fig.4-14.

**NOTE**

- To minimize the influence of noise on the output, use a 2-core shielded wire or a twisted-pair wire to connect the control terminals and the external contact points. If using a shielded wire, connect the shield to the chassis ground terminal.
- The control terminal [10] is "common" for the control circuit. It is internally connected to +S on the unit.
- The release voltage across the control terminals [10] and [11] is approx. 5 V, and the short circuit current is approx. 1.5 mA.
- Use external contact points of rated 10 VDC min. and 10 mA min.
- For long-distance wiring, use a small relay and extend the coil side of that relay.

4. Re-check that the connections on the terminal board and the switch settings are correct.

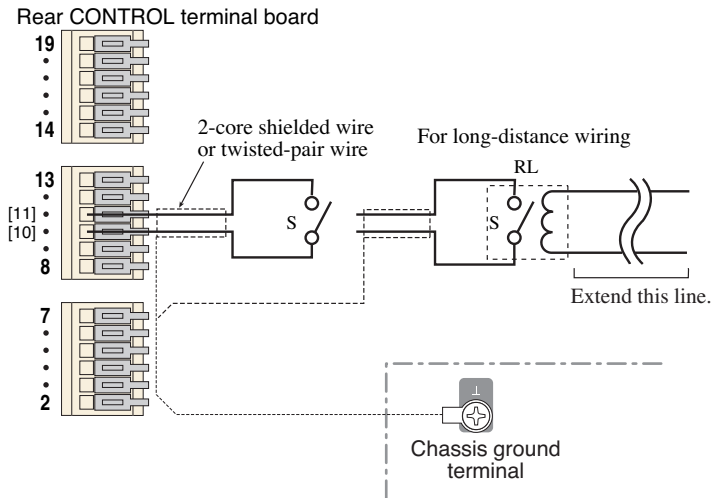

Fig.4-14 Output ON/OFF control connection

## 4.4 Master-slave-control parallel operation

It is possible to increase the current capacity by connecting a maximum two slave units in parallel to one master unit. In a master-slave-control parallel operation system, the output preset for all the units connected in parallel can be provided only on the master unit.

To perform such master-slave-control parallel operation, an electrolytic capacitor should be connected to the load terminals.

---

**⚠ WARNING** • Never attempt to connect wires to the control terminals while the POWER switch turned on. This may result in electric shock or damage to the internal circuitry.

**⚠ CAUTION** • Parallel connection is possible only for the PAN-A series power supplies that have the same rated output voltage and rated output current. Connecting power supplies of different rated outputs in parallel may cause malfunction.

- Perform parallel operation only when using the master-slave-control parallel operation system. Parallel connection of output alone may cause unit failure.

---

### ■ Presetting of OVP trip points in parallel operation

When carrying out parallel operation, OVP (overvoltage protection) trip points should be preset for both the master unit and for all slave units. For example, if the master unit becomes unable to control the slave units - because, for example, its POWER switch is inadvertently turned off during parallel operation - the slave units may output their maximum output voltage. If an appropriate OVP trip point has been preset for these units, however, the load can still be protected.

In parallel operation, the OVP trip points for slave units should be set to slightly higher values than that used for the master unit. However, do not preset them to a value exceeding 105 % of the rated voltage.

If the OVP trip points for the slave units are preset to a value below that of the master unit, their overvoltage protection will function first, turning off output from the slaves but not from the master unit.

## Connection and setup procedure

1. Turn off the OUTPUT switch of each unit.
2. Turn off the POWER switch of each unit.
3. Determine the master unit.
4. Preset the OVP (overvoltage protection) trip points for the master and slave units.

---

**NOTE** • Preset the OVP trip points for the slave units to a value slightly higher than that used for the master unit. However, do not preset them to a value exceeding 105 % of the rated voltage.

---

5. Set the control switch S5 of the master unit and slave units to the positions shown in Fig.4-15.

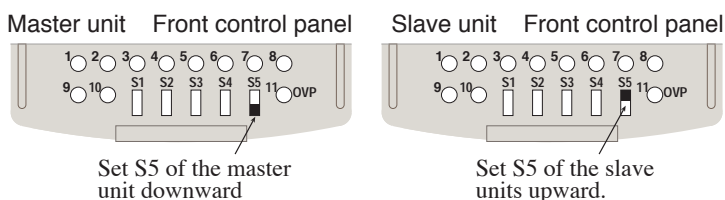

Fig.4-15 Control switch presetting for master-slave-control parallel operation

6. Connect the master unit and slave unit as shown in Fig.4-16. Fig.4-16 shows an example of how the rear output terminals are connected in parallel for two slave units

---

**WARNING** • Use a load cable of sufficient current capacity to cover the rated value.

- After parallel connection, mount the output terminal cover (on the front or rear panel). To mount the front auxiliary output terminal cover, see "3.4 Mounting the auxiliary output terminal cover".

**CAUTION** • Use wires of the same length and size for connecting the load and each unit. Use of varying lengths and size may cause different output current from each unit.

- To assure good connection of load cables, use crimped terminals.
  - Position each unit with sufficient space around it. Do not stack units a top one another.
- 

- NOTE**
- To minimize the influence of noise on the output, use a 2-core shielded wire or a twisted-pair wire to connect across the control terminals.
  - When using shielded wires, connect the shield between the master and slave units to the chassis ground terminal of the master unit. Connect the shield between the slave units to the shield between the master and slave units.
  - When performing remote sensing in master-slave-control parallel operation, prepare the sensing wiring only for the master unit. For information on connection, see "4.2 Remote sensing".
- 

7. Connect an electrolytic capacitor (C) with a capacity of a few hundreds of  $\mu\text{F}$  to a few tens of thousands of  $\mu\text{F}$  to the load terminals as necessary.
- 

- CAUTION** • Use a capacitor (C) whose withstand voltage is 120 % or more of the unit's rated voltage.
- 

- NOTE**
- If the length of wiring to a load extends to 3 m or more, the phase shift caused by the inductance and capacitance of the wiring becomes non-negligible, thereby causing oscillation. In such cases, the capacitor (C) prevents oscillation.
- 

8. Re-check that the connections and the switch settings are correct.



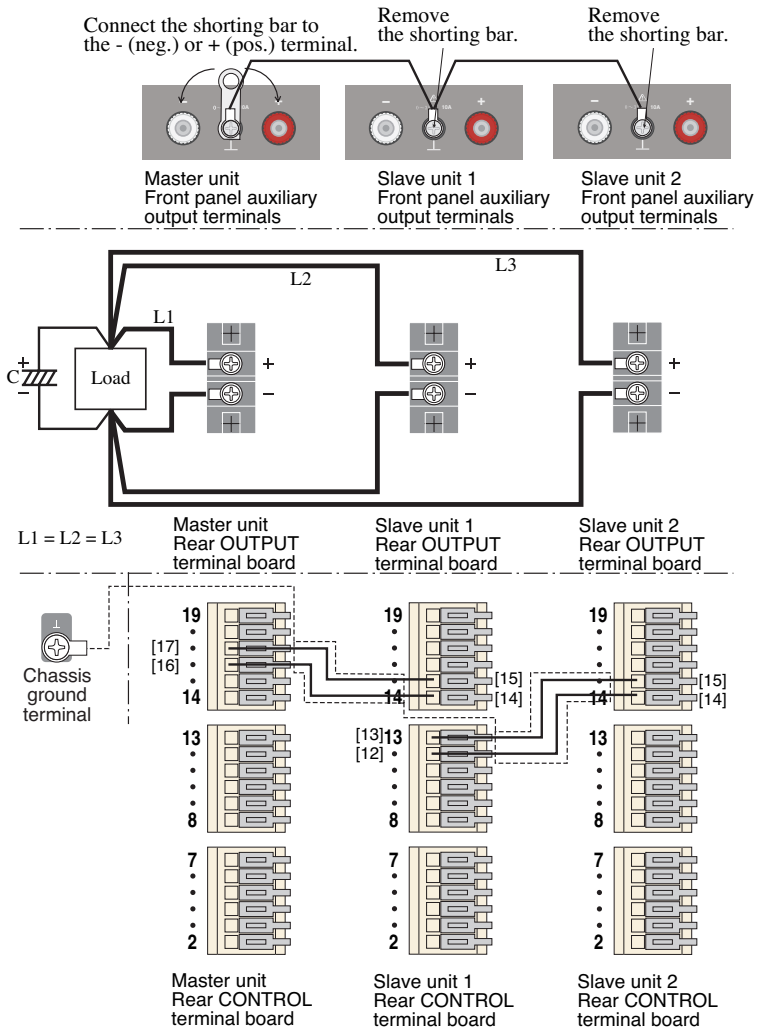

Fig.4-16 Connection for master-slave-control parallel operation

## Starting master-slave-control parallel operation

---

- ⚠ CAUTION** • To start master-slave-control parallel operation, always follow the procedure below. Because the slave units are under control of the master unit, if the procedure is incorrectly observed, the slave units may output their maximum output voltage.
- 

1. Check that the OUTPUT switch of each unit is turned off.
  2. Turn on the POWER switch of the master unit.
  3. Turn on the POWER switch of each slave unit.
  4. Turn the VOLTAGE control knob and the CURRENT control knob of each slave unit fully clockwise.
- 

- NOTE** • Preset the output of each slave unit to the maximum level, so that it can follow the preset output of the master unit.
- 

5. While presetting the LIMIT switch of the master unit, preset the output voltage and current.
- 

- NOTE** • The total output current setup value can be found by multiplying the preset value of the master unit by the number of units used for the parallel operation.
- If the limit switch of the slave unit is pressed, the current display changes to a display not related to the output current.
- 

6. Turn on the OUTPUT switch of each slave unit.  
"CC" lights up on the control panel of each slave unit, indicating that the unit is in constant current operation mode.
7. Turn on the OUTPUT switch of the master unit.  
"CV" lights up on the master unit control panel, indicating that the unit is in constant voltage operation mode.  
The same output voltage and current displayed on the master unit are also displayed on all the slave units. This means that the total current of all the units is applied to the load.

## Finishing the master-slave-control parallel operation

---

**⚠ CAUTION** • To finish master-slave-control parallel operation, always observe the following procedure. If the POWER switch of the master unit is turned off while parallel operations are still being carried out, the slave units may output their maximum output voltage.

---

1. Turn off the OUTPUT switch of the master unit.
2. Turn off the OUTPUT switch of each slave unit.
3. Turn off the POWER switch of each slave unit.
4. Turn off the POWER switch of the master unit.

## 4.5 Master-slave-control series operation

It is possible to increase the output voltage by connecting several slave units in series to one master unit. In a master-slave-control series operation system, a preset output for all the units connected in series can be designated only from the master unit.

### Number of units connectable in series:

The number of slave units to be connected in series is determined by the rated output voltage and isolation voltage of each unit.

Taking the PAN35-10A as an example for series connection:

Since the rated output voltage is 35 V, and the isolation voltage is  $\pm 250$  V,  $250/35 = 7.1$ , i.e., up to 7 units including the master unit can be connected in series.

The rated output voltage and the isolation voltage are described in Chapter 7 "Specifications".

---

**⚠ WARNING**

• Be sure to observe the limitation on the maximum number of units that can be connected in series. If the maximum output voltage exceeds the isolation voltage, it may create a danger of electric shock.

**⚠ CAUTION**

- Series connection is possible only for the PAN-A series power supplies that have the same rated output voltage and rated output current. Connecting power supplies of different rated outputs in series may cause malfunction.
- Perform series operation only when using the master-slave-control series operation system. Series connection of output alone may cause unit failure.
- In case of master-slave-control series operation, the master unit, slave unit 1, and slave unit 2 are started in this order. Thus, the rise in output will be delayed in comparison with single-unit operation. This may cause AC ripple components to be superimposed on the output voltage. If rise waveform becomes a problem, use a single high-output-voltage unit.

---

**NOTE**

- For output lines connecting the power supplies, select the shortest and heaviest gauge wires. A large voltage drop in the

output lines results in a large potential difference between the power supplies or large load variations.

### ■ Presetting of OVP trip points in series operation

When carrying out series operation, OVP (overvoltage protection) trip points should be preset for both the master unit and for all slave units.

In series operation, the OVP trip points for slave units should be set to slightly higher values than that used for the master unit.

If the OVP trip points for the slave units are preset to a value below that of the master unit, their overvoltage protection will function first, turning off output from the slaves but not from the master unit.

#### Connection and setup procedure

1. Turn off the OUTPUT switch of each unit.
2. Turn off the POWER switch of each unit.
3. Determine the master unit.
4. Preset the OVP (overvoltage protection) trip points for the master and slave units.

**NOTE** • Preset the OVP trip points for the slave units to a value slightly higher than that used for the master unit.

5. Set the control switch S1 of the master unit and slave units to the positions shown in Fig.4-17.

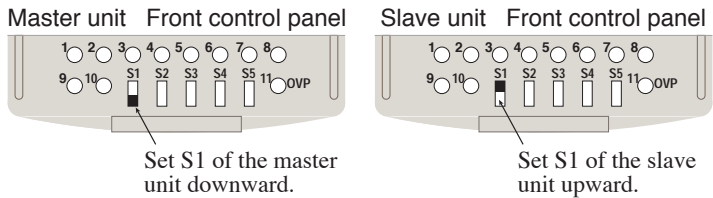

Fig.4-17 Presetting of control switches for master-slave-control series operation

6. Connect the master unit and slave units shown in Fig.4-18. Fig.4-18 shows an example of how the rear output terminals are connected in series for two slave units. When performing remote sensing in master-slave-control series operation, see Fig.4-19.

---

**⚠ WARNING** • Use a load cable of sufficient current capacity to cover the rated value.

- After series connection, mount the output terminal cover (on the front or rear panel). To mount the front auxiliary output terminal cover, see "3.4 Mounting the auxiliary output terminal cover".

**⚠ CAUTION** • To assure good connection of load cables and control wires, use crimped terminals.

- Position each unit with sufficient space around it. Do not stack units a top one another.
- Connect any one of the + (pos.) and - (neg.) output terminals to the ⊥ (chassis ground) terminal, using a shorting bar.

---

7. Re-check that the connections and the switch settings are correct.

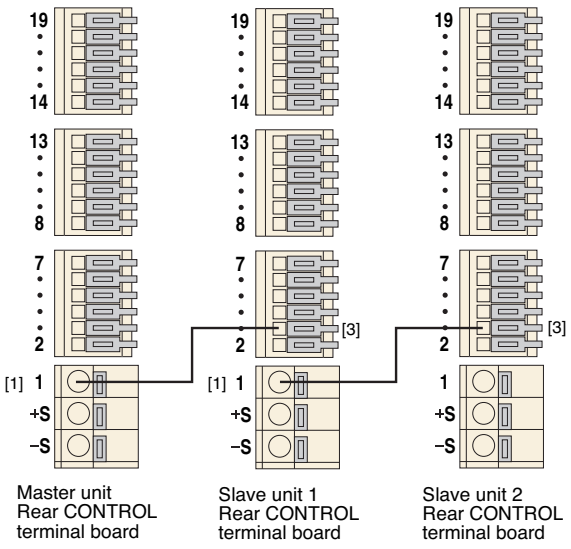
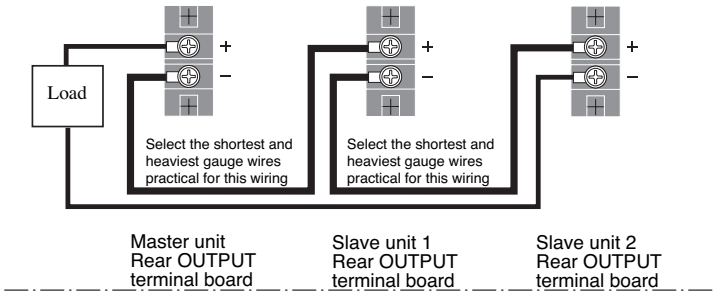
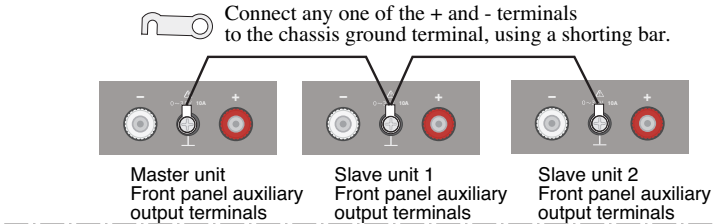

Fig.4-18 Connection for master-slave-control series operation

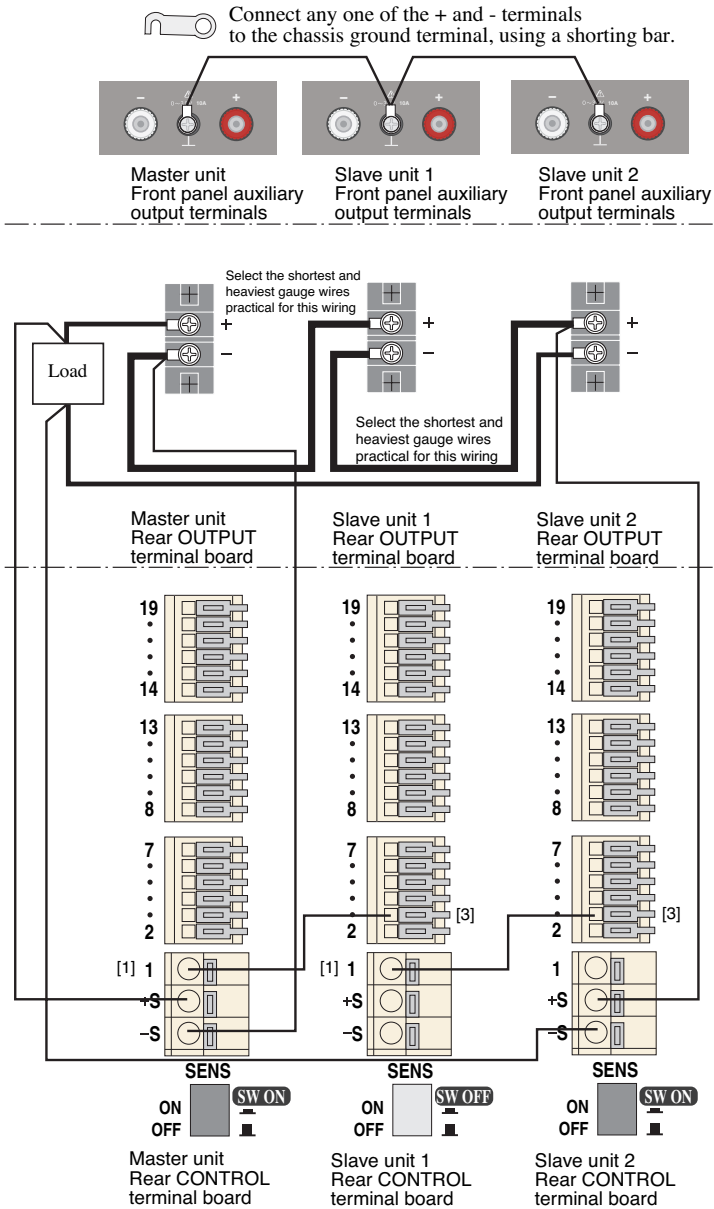

Fig.4-19 Connection for master-slave-control series operation using sensing



- 
- NOTE** • For external resistor (R<sub>ext</sub>), use a 1 W or larger metal film or wire-wound type resistor with a good temperature coefficient and small aging effect.
- 

## Starting master-slave-control series operation

- 
- CAUTION** • To start master-slave-control series operation, always follow the procedure below. The slave units are under control of the master unit, so do not turn on the POWER switches of the slave units first.
- 

1. Check that the OUTPUT switch of each unit is turned off.
2. Turn on the POWER switch of the master unit.
3. Turn on the POWER switch of each slave unit.
4. Turn the VOLTAGE control knob and the CURRENT control knob of each slave unit fully clockwise.

- 
- NOTE** • Preset the output of each slave unit to the maximum level, so that it can follow the preset output of the master unit.
- 

5. While pressing the LIMIT switch of the master unit, preset the output voltage and current.

- 
- NOTE** • The total output voltage setup value can be found by multiplying the preset value of the master unit by the number of units used for the series operation.
- 

6. Turn on the OUTPUT switch of the slave unit.  
"CV" lights up on the slave unit control panel, indicating that the unit is in constant voltage operation mode.
7. Turn on the OUTPUT switch of the master unit.  
"CV" lights up on the control panel of the master unit, indicating that the unit is in constant voltage operation mode.

The same output voltage and current displayed on the master unit are also displayed on each slave unit. This means that the total voltage of all the units is applied to the load.

## Finishing the master-slave-control series operation

---

 **CAUTION** • To finish master-slave-control series operation, always follow the procedure below. If the POWER switch of the master unit is turned off while series operations are still being carried out, the slave units may malfunction.

---

1. Turn off the OUTPUT switch of the master unit.
2. Turn off the OUTPUT switch of each slave unit.
3. Turn off the POWER switch of each slave unit.
4. Turn off the POWER switch of the master unit.

## 5.1 Front panel

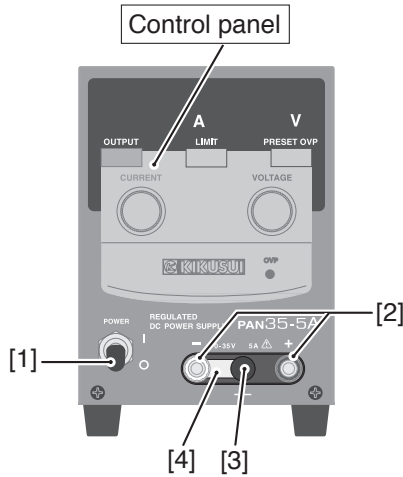

Fig.5-1 Front panel of PAN-A series model 175W

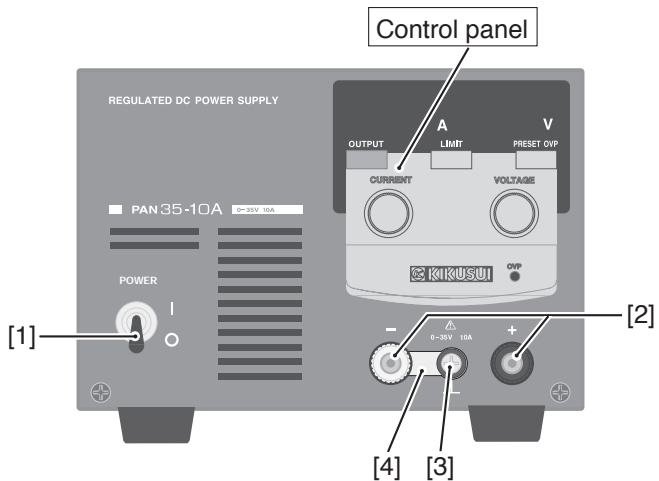

Fig.5-2 Front panel of PAN-A series model 350W

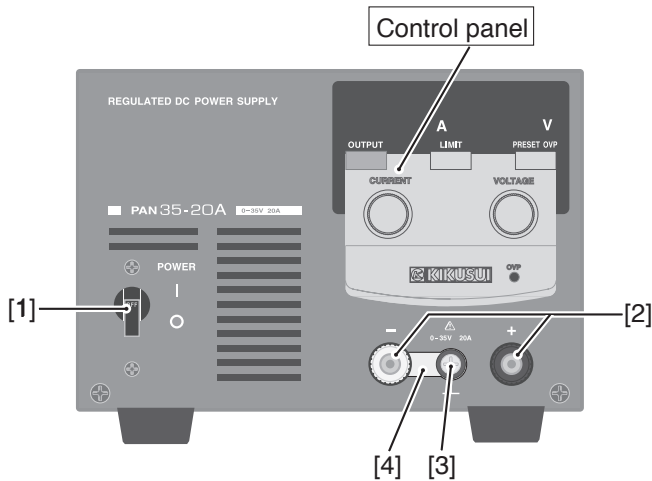

Fig.5-3 Front panel of PAN-A series model 700W

## [1] POWER

Turns the power of the unit on and off. Flip up the lever to turn the power ON (|), and flip it down to turn the power OFF (○).

## [2] +, - (auxiliary output terminals) ⚠

These terminals are designed for handy use in supplying output from the unit. Output from these terminals, however, may not satisfy the specifications of the unit.

---

**⚠ WARNING** • To avoid electric shock, always turn off the POWER switch whenever it is necessary to touch the terminals.

---

## [3] ⊥ (chassis ground terminal)

This terminal is connected to the chassis of the unit. This terminal and the auxiliary output + (pos.) or - (neg.) terminal should usually be connected using the shorting bar.

## [4] Shorting bar for grounding chassis

This is used to connect the auxiliary output + (pos.) or - (neg.) terminal to the chassis ground terminal (⊥).

## Control Panel

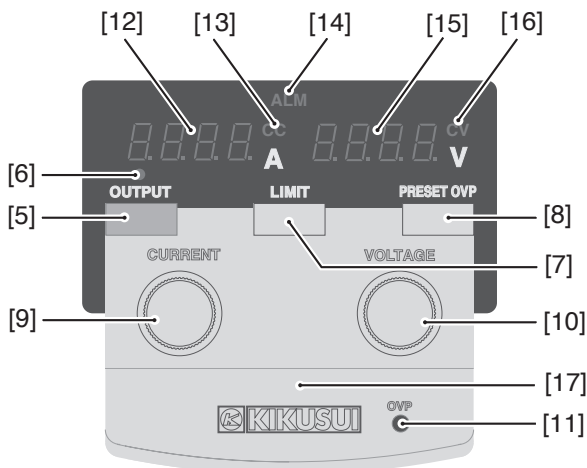

Fig.5-4 PAN-A series control panel

### [5] OUTPUT

Turns the output on and off. It is turned on at pushed.

When the output is turned off, the output circuit is set into a state of high impedance (several  $k\Omega$ ).

### [6] OUTPUT ON indication

This LED lights up when the output is turned on.

### [7] LIMIT

This is used to preset or check the output voltage and the output current. While pressing this switch, the currently preset voltage and current are displayed.

### [8] PRESET OVP

This is used to preset or check the OVP (overvoltage protection) voltage. While this switch is held down, the currently preset OVP voltage is displayed.

### [9] CURRENT

This is used to set output current for constant current operation mode. (10 turns)

## **[10] VOLTAGE**

This is used to set output voltage for constant voltage operation mode. (10 turns)

## **[11] OVP**

This is the OVP (overvoltage protection) control variable resistor, and used to preset the trip point of the OVP circuit.

## **[12] Ammeter**

Indicates the output current when the OUTPUT switch is turned on. Indicates the output current limit when the LIMIT switch is pressed.

## **[13] CC**

"CC" (Constant Current) LED is displayed when the unit is in its constant current operation mode.

## **[14] ALM**

"ALM" (alarm) LED lights up if any one of the following protection circuits is activated.

- 1) Overvoltage protection circuit (OVP)
- 2) Overheat protection circuit (protects the semiconductor cooler from becoming overheated)
- 3) Voltage detection circuit (protects smoothing capacitors in the phase control circuit from overvoltage)
- 4) Overcurrent protection circuit (protects the internal circuit from overcurrent caused by erroneous operation of external controls)

Circuits other than the overvoltage protection circuit are intended to protect the internal circuit of the unit; a trip point cannot be set for them. The overcurrent protection's trip point is set to approx. 110 % of the rated output current.

In the case of the model 700W, the POWER switch is shut down as soon as the ALM lamp lights up, and all displays on the panel go off. Except an alarm by the overcurrent protection circuit.

## **[15] Voltmeter**

Indicates output voltage when the OUTPUT switch is turned on. Indicates the output voltage limit when the LIMIT switch is pressed. Indicates the OVP trip voltage when the PRESET OVP switch is pressed.

## **[16] CV**

"CV" (Constant Voltage) LED is displayed when the unit is in its constant voltage operation mode.

## **[17] Front sub-panel cover**

This is used to cover the switches and variable resistors that are seldom used. To open it, press both sides of the cover and pull it forward. Beneath the cover are the remote control switches and variable resistors for calibration.

## 5.2 Rear panel

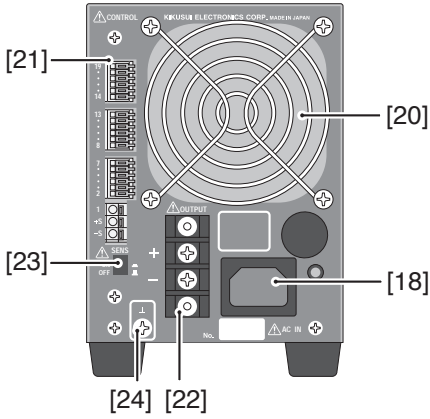

Fig.5-5 Rear panel of PAN-A series model 175W

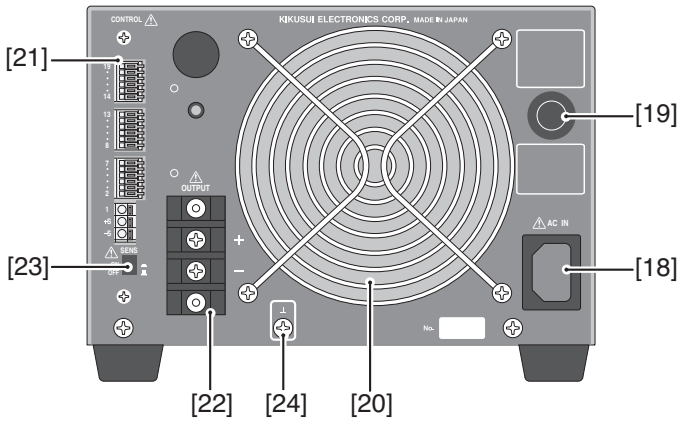

Fig.5-6 Rear panel of PAN-A series model 350W



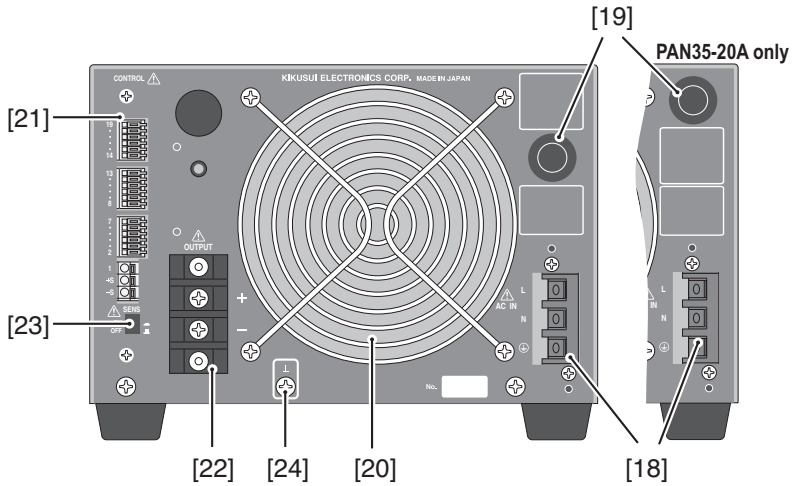

Fig.5-7 Rear panel of PAN-A series model 700W

### [18] AC IN ⚠

AC input terminals. Connect the supplied AC power code.

- 
- ⚠ WARNING**
- Incorrect handling may cause electric shock. Always follow the instructions in section "1.5 Connecting the AC power code".
  - Make sure that the ground terminal ⊕ is securely grounded. For details, see "1.6 Grounding"
- 

### [19] FUSE ⚠

Fuse holder. A AC input fuse element is put in this.

- 
- ⚠ WARNING**
- Incorrect handling may cause electric shock. Always follow the instructions in "1.4 Checking the input fuse".
- 

- 
- NOTE**
- The input fuses of the model 175W are located inside, and no fuse holder is found on the rear panel.
-

## [20] Exhaust port

This port uses a fan to exhaust heated air from inside. Keep sufficient space around the unit for good ventilation.

## [21] CONTROL ⚠

This is the terminal board used for applied operations such as remote control.

---

**⚠ WARNING** • Incorrect handling may cause electric shock. For details, see Chapter 4 "Applied Operation".

---

## [22] OUTPUT ⚠

This is the output terminal board.

---

**⚠ WARNING** • To avoid electric shock, always turn off the POWER switch whenever it is necessary to touch the terminals.

---

## [23] SENS ⚠

Turn this switch on when using the sensing function. It is turned on at pushed.

---

**⚠ CAUTION** • Do not turn on/off the SENS switch while the POWER switch is on. For details, see "4.2 Remote sensing".

---

## [24] ⊥

Chassis ground terminal.

To maintain the unit's original performance as long as possible, conduct periodic checks and maintenance.

## 6.1 Cleaning

When the panel gets soiled, wet a piece of soft cloth with a water-diluted neutral detergent, and wipe the panel softly.

The air intake port on the front panel is equipped with an air filter inside. Suck out any dust with a vacuum cleaner.

- 
-  **CAUTION** • For maintenance work, always turn off the POWER switch, and either disconnect the AC power code.
- Do not use volatile solvents such as thinner and benzine. They may discolor the unit surface coating, erase printed characters, or make face of display opaque.
- 

## 6.2 Inspection

### Power code

Check that there is no damage on the insulation coating, and that the plug is firmly attached and free from cracks.

- 
-  **WARNING** • Breaks in the insulation coating may cause electric shock. If a break is found, immediately stop using the unit.
- 

To purchase accessories, contact your Kikusui agent/distributor.

## 6.3 Adjustment

The unit is factory-adjusted based on control from the front panel (i.e., local control). However, when using the remote control function (except when turning outputs ON/OFF using an external contact), or when switching operation from remote control to local control, re-adjustment of following output voltage and output current are necessary.

In the course of long use of the unit, however, other items may also need adjustment due to the effect of age. For all such adjustments, contact your Kikusui agent/distributor.

### 6.3.1 Test equipment required

For adjustment, the following equipment is necessary.

- DC voltmeter (DVM) with measuring accuracy of 0.02 % max.
- Shunt resistor with accuracy of 0.1 % max.

### 6.3.2 Adjustment procedure

Adjustment items can be roughly classified into two areas: the voltage system and the current system. These items may change depending on what is to be controlled by remote control. It is not necessary, however, to adjust remote control for the output ON/OFF.

If remote control is used for the output current by means of external voltage, adjustment of the current system is necessary.

Adjustment is conducted by using the adjusting variable resistors "2" and "4" - "8", located under the front panel cover.

---

**NOTE**

- Never touch the variable resistors "1", "3", "9" and "10", as they are not involved in the user adjustment process. If you have moved any of them by mistake, re-adjustment is necessary. In such cases, contact your Kikusui agent/distributor.
-

## Voltage system adjustment procedure

The voltage system includes the following three items. Since all the items are related to one another, adjust them all in the following procedure.

- Output voltage offset
- Output voltage in full scale
- Output voltage display in full scale

### ■ Connection of equipment

---

**⚠ WARNING** • To avoid electric shock, turn off the unit POWER switch before making device connections.

---

1. Turn off the OUTPUT switch.
2. Turn off the POWER switch.
3. Check that the SENS switch is turned off.  
If the SENS switch is turned on, it is impossible to adjust correctly.
4. Connect a DVM as shown in Fig.6-1.
5. Connect the - (neg.) terminal and the chassis ground terminal (⊥) with the shorting bar.

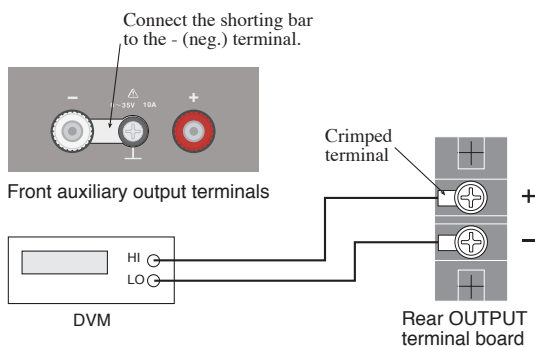

Fig.6-1 Connection for voltage system adjustment

6. Turn on the POWER switch.

## ■ Warming-up

- 
- NOTE** • To minimize adjustment error affected by initial drift, warm up the unit at least 30 minutes before starting adjustment.
- 

7. Set the output voltage to the rated output voltage.  
For local control, turn the VOLTAGE control knob fully clockwise. For remote control, set the control signal to 10 V or 9.5 k $\Omega$ .
8. Turn on the OUTPUT switch.
9. Turn off the OUTPUT switch 30 minutes or more later.

### Output voltage offset

10. Set the output voltage to 0 V.  
For local control, turn the VOLTAGE control knob fully counter-clockwise. For remote control, set the control signal to 0 V or 0  $\Omega$ .
11. Turn on the OUTPUT switch.
12. Turn the CURRENT control knob clockwise until the unit enters constant voltage operation. (Offset adjustments must always be conducted in constant voltage operation.)  
When the current is remote-controlled externally and the current setting is 0 A, the unit may operate at a constant current, depending on the offset balance. To avoid this problem, turn the current control knob so that a current equal to about 10 % of the rated value can be provided at any time.
13. Using variable resistor "2", adjust the output voltage to 0 V.

### Output voltage in full scale

14. Set the output voltage to the maximum.  
For local control, turn the VOLTAGE control knob fully clockwise. For remote control, set the control signal to 10.5 V or 10 k $\Omega$ .
15. Using variable resistor "4", adjust the output voltage to 105 % of the rated output voltage.

- 
- CAUTION** • The maximum output voltage of the unit is specified at 105 % of the rated output voltage. It is possible to adjust to a level higher than 105 % using variable resistor "4", but this may damage the unit.
-

- 
- NOTE** • For remote control using external voltage, a 10 V control signal may be selected and adjusted to 100 % of the rated output voltage of the unit.
- 

### Output voltage display in full scale

16. Adjust with variable resistor "5" so that the output voltage indication of the unit equals the indication on the external digital voltmeter (DVM) in a rated-voltage output condition.

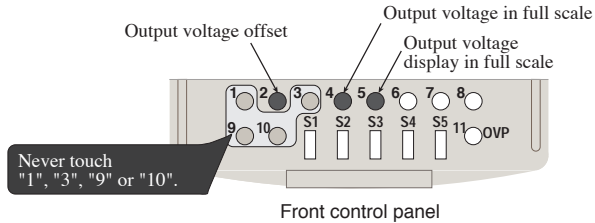

Fig.6-2 Voltage system adjustment variable resistor

## Current system adjustment procedure

The current system includes the following three items. Since all the items are related to one another, adjust them all in the following procedure.

- Output current offset
- Output current in full scale
- Output current display in full scale

### ■ Connection of equipment

1. Turn off the OUTPUT switch.
2. Turn off the POWER switch.
3. Check that the SENS switch is turned off.

If the SENS switch is turned on, it is impossible to adjust correctly.

4. Connect a shunt resistor and DVM as shown in Fig.6-3.
5. Connect the - (neg.) terminal and the chassis ground terminal ( $\perp$ ) with the shorting bar.

---

**WARNING** • Use load cables of sufficient current capacity to cover the rated current.

---

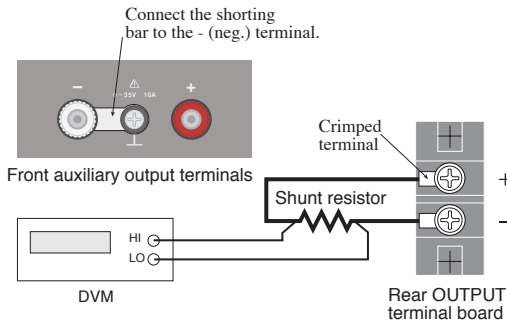

Fig.6-3 Connection for current system adjustment

6. Turn on the POWER switch.



## ■ Warming-up

---

**NOTE** • To minimize adjustment error affected by initial drift, warm up the unit at least 30 minutes before starting adjustment.

---

7. Set the output current to the rated output current.  
For local control, turn the CURRENT control knob fully clockwise. For remote control, set the control signal to 10 V or 9.5 k $\Omega$ .
8. Turn on the OUTPUT switch.
9. Turn off the OUTPUT switch 30 minutes or more later.

### Output current offset

10. Set the output current to 0 A.  
For local control, turn the CURRENT control knob fully counter-clockwise. For analog remote control, set the control signal to 0 V or 0  $\Omega$ .
11. Turn on the OUTPUT switch.
12. Turn the VOLTAGE control knob clockwise until the unit enters constant current operation. (Offset adjustments must always be conducted in constant current operation.)  
When the voltage is remote-controlled externally and the voltage setting is 0 V, the unit may operate at a constant voltage, depending on the offset balance. To avoid this problem, turn the voltage control knob so that a voltage equal to about 10 % of the rated value can be provided at any time.
13. Using variable resistor "6", adjust the output current to 0 A.

### Output current in full scale

14. Set the output current to the rated output current.  
For local control, turn the CURRENT control knob fully clockwise. For remote control, set the control signal to 10.5 V or 10 k $\Omega$ .
15. Using variable resistor "7", adjust the output current to 105 % of the rated output current.

---

**CAUTION** • The maximum output current of the unit is specified as 105 % of the rated output current. It is possible to adjust to a level higher than 105 % using variable resistor "7", but this may damage the unit.

---

**NOTE**

- For remote control using external voltage, a 10 V control signal may be selected and adjusted to 100 % of the rated output current of the unit.

**Output current display in full scale**

16. Adjust with variable resistor "8" so that the output current indication of the unit equals the current value obtained from the indication on the external digital voltmeter (DVM) and shunt resistor, in a rated-current output condition.

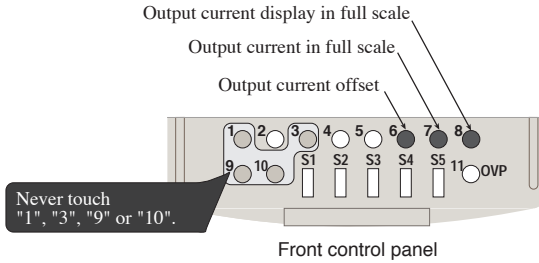

Fig.6-4 Current system adjustment variable resistor

## 6.4 Malfunctions and Causes

This section describes some symptoms of possible malfunctions encountered during use of the unit, along with appropriate remedies.

Here, we provide seven typical symptoms and possible check items for each; you simply find the relevant item. Ideally, you will be able to cure these symptoms without difficulty.

When you find a relevant item, follow the corresponding remedy. If this does not solve or improve the problem, or if no relevant item can be located, please contact your Kikusui agent/distributor.

### ■ Symptom 1: The control panel displays nothing.

Check item	Cause and remedy
<input type="checkbox"/> Check that the wires to the AC input terminals are connected correctly.	<ul style="list-style-type: none"><li>• Wiring to the L, N, and GND terminals is wrong. Connect the wires to these terminals correctly by referring to "1.5 Connecting the AC power code".</li></ul>
<input type="checkbox"/> Check that the AC power cord is plugged into a power socket securely.	<ul style="list-style-type: none"><li>• Plug the AC power cord into the socket securely.</li></ul>
<input type="checkbox"/> Check that the AC Power code contains no broken wires.	<ul style="list-style-type: none"><li>• Replace the power code with a new AC power code.</li></ul>
<input type="checkbox"/> Check that the input fuse is not blown. (For models 350W or 700W only)	<ul style="list-style-type: none"><li>• Input voltage is high, exceeding the input voltage range. Supply a voltage within the input voltage range. Replace the fuse by referring to "1.4 Checking the input fuse".</li><li>• The fuse appears to have suffered long-term damage from inrush currents. Replace it by referring to "1.4 Checking the input fuse".</li></ul>

**■ Symptom 2: When you turn on the POWER switch, it is turned off or the "ALM" LED lights up.**

Check item	Cause and remedy
<input type="checkbox"/> Check that switch S4 on the control panel has not been set to on (upper position).	<ul style="list-style-type: none"> <li>The overcurrent protection circuit has been activated. Switch S4 should be off (lower position) when output current control using an external resistor is not carried out.</li> </ul>
<input type="checkbox"/> Check that control wires are secure in controlling output with external resistor.	<ul style="list-style-type: none"> <li>The overcurrent protection circuit has been activated. Connect the control wires correctly by referring to "4.3.3 Controlling output current with external resistor"</li> </ul>
<input type="checkbox"/> Check that a switch used for switching the resistor is not open during switching in external resistor-based control.	<ul style="list-style-type: none"> <li>The overcurrent protection circuit has been activated. Replace the switch with a shorting-type or continuous-type switch. See the CAUTION note in "4.3.3 Controlling output current with external resistor"</li> </ul>
<input type="checkbox"/> Check that input voltage is not distorted into a square waveform.	<ul style="list-style-type: none"> <li>The voltage detection circuit of the phase control circuit has been activated. If the crest factor of input voltage is 1.2 or less, the phase control circuit may malfunction. In this case, use a regulated AC power supply as an input source. The capacity of the regulated AC power supply requires at least twice the power consumption (VA) of the unit.</li> </ul>

**■ Symptom 3: When you turn on the OUTPUT switch, the POWER switch is turned off or the "ALM" LED lights up.**

Check item	Cause and remedy
<input type="checkbox"/> Check that the OVP trip point is not preset to a level below output voltage.	<ul style="list-style-type: none"> <li>The overvoltage protection circuit has been activated. Preset the OVP trip point to a level above the output voltage. See "3.2.1 OVP(Over Voltage Protection) trip point pre-setting".</li> </ul>
<input type="checkbox"/> Check that the actual output voltage is not higher than voltage displayed on the panel.	<ul style="list-style-type: none"> <li>The overvoltage protection circuit has been activated. The voltage system requires calibration. Re-calibrate the unit by referring to "6.3.2 Adjustment procedure".</li> </ul>
<input type="checkbox"/> Check that the SENS switch is not on.	<ul style="list-style-type: none"> <li>The overvoltage protection circuit has been activated. The SENS switch should be off when the remote sensing function is not used.</li> </ul>
<input type="checkbox"/> Check that no special load is connected.	<ul style="list-style-type: none"> <li>The overvoltage protection circuit has been activated. See the item "Load" in "2.4 Load".</li> </ul>
<input type="checkbox"/> Check that control wires are secure in controlling output with external resistor.	<ul style="list-style-type: none"> <li>The overvoltage protection circuit or overcurrent protection circuit has been activated. Connect the control wires correctly by referring to Sections "4.3.1 Controlling output voltage with external resistor" or "4.3.3 Controlling output current with external resistor".</li> </ul>
<input type="checkbox"/> Check that control wires are secure and that external voltage is not excessive in controlling output with external voltage.	<ul style="list-style-type: none"> <li>The overvoltage protection circuit or overcurrent protection circuit has been activated. Connect the control wires correctly by referring to Sections "4.3.2 Controlling output voltage with external voltage" or "4.3.4 Controlling output current with external voltage".</li> </ul>
<input type="checkbox"/> Check to see if the fan runs normally.	<ul style="list-style-type: none"> <li>The overheat protection circuit has been activated. Ambient temperature has exceeded the operating ambient temperature or the fan has possibly failed. If the fan does not run when the unit is used in the range of 0 °C to 40 °C.</li> </ul>

**■ Symptom 4: No output is generated even when the OUTPUT switch is turned on.**

Check item	Cause and remedy
<input type="checkbox"/> Check to see if both the "CV" and "CC" LEDs are off.	<ul style="list-style-type: none"> <li>• The VOLTAGE and CURRENT control knobs have been turned fully counterclockwise. Both LEDs may not light up, depending on the offset setting conditions. This is not a form of equipment failure. Set the required output using the VOLTAGE and CURRENT control knobs.</li> </ul>
<input type="checkbox"/> Check that the VOLTAGE or CURRENT control knob has not been turned fully counterclockwise.	<ul style="list-style-type: none"> <li>• Set the required output using the VOLTAGE or CURRENT control knob.</li> </ul>
<input type="checkbox"/> Check to see if the "OUTPUT ON" LED is off.	<ul style="list-style-type: none"> <li>• The external contact points have been closed in output ON/OFF control using external contact points. See "4.3.5 Output ON/OFF control".</li> </ul>
<input type="checkbox"/> Check that the switches S1, S3, and S5 on the control panel have not been set to on (upper position).	<ul style="list-style-type: none"> <li>• For control from the front panel, control switches S1, S3, and S5 should all be set to off (lower position). See "4.3 Analog remote control".</li> </ul>

■ **Symptom 5: No output is generated or the output is unstable even when the OUTPUT switch is turned on.**

Check item	Cause and remedy
<input type="checkbox"/> Check to see if the operation mode changes from CV to CC or CC to CV.	<ul style="list-style-type: none"> <li>• Turn the control knob (VOLTAGE or CURRENT) that has been clamped, in the clockwise direction. If the knob has already been turned fully clockwise, it is necessary to use a power supply with greater capacity.</li> </ul>
<input type="checkbox"/> Check that the SENS switch is not on.	<ul style="list-style-type: none"> <li>• The SENS switch should be off when the remote sensing function is not used.</li> </ul>
<input type="checkbox"/> Check to see if it has been more than 30 minutes since a power-on.	<ul style="list-style-type: none"> <li>• The output is unstable due to initial drift. Carry out a warm-up (power application) for at least 30 minutes.</li> </ul>
<input type="checkbox"/> Check to see if both the "CV" and "CC" LEDs are lit.	<ul style="list-style-type: none"> <li>• Input voltage is low, i.e., below the input voltage range. Supply voltage within the input voltage range.</li> <li>• Ambient temperature is less than the operating ambient temperature. Use the unit within a range of 0 °C to 40 °C.</li> <li>• If remote sensing and master-slave-control parallel operations are carried out, causing oscillation, add a capacitor to the load end. See "4.2 Remote sensing" and "4.4 Master-slave-control parallel operation".</li> <li>• The internal circuit may be faulty. If a load such as battery is connected to the output terminals directly, the internal circuit may break or the output fuse may blow. See the item "Load" in "2.4 Load". Stop using the unit immediately and contact us for repair service.</li> </ul>
<input type="checkbox"/> Check to see if current flows even though no load is connected.	<ul style="list-style-type: none"> <li>• The internal circuit may be broken. If a capacitor of large capacity or a battery is connected in reverse polarity, a diode for preventing reverse connection will break. Stop using the unit immediately and contact us for repair service.</li> </ul>
<input type="checkbox"/> Check to see if output is generated even though the OUTPUT switch is turned off.	<ul style="list-style-type: none"> <li>• The internal circuit may be broken. Application of voltage higher than the rating of the unit to the output terminals will cause the bleeder circuit to break. If a load such as a battery is connected to the output terminals directly, the power transistors will break. Stop using the unit immediately and contact us for repair service.</li> </ul>

### ■ Symptom 6: Large output ripple

Check item	Cause and remedy
<input type="checkbox"/> Check that the input voltage is not below the correct range.	• Supply a voltage within the input voltage range.
<input type="checkbox"/> Check that the output terminals and chassis ground terminal are not floated.	• Being subjected to induction of input power frequency (50/60 Hz). If possible, connect the output terminals to the ground using a capacitor of 0.1 $\mu$ F or more.
<input type="checkbox"/> Check that there is no intense magnetic or electric field generating source nearby.	• Being subjected to electromagnetic induction. Take measures such as locating the unit away from such generating sources and using twisted cables.
<input type="checkbox"/> Check that external voltage is not noisy in controlling output with external voltage.	• Take measures against noise by referring to Sections "4.3.2 Controlling output voltage with external voltage" or "4.3.4 Controlling output current with external voltage".
<input type="checkbox"/> Check that the SENS switch is not on.	• The SENS switch should be off when the remote sensing function is not used.

### ■ Symptom 7: Display value does not indicate output value

Check item	Cause and remedy
<input type="checkbox"/> Check that the SENS switch is not on.	• The SENS switch should be off when the remote sensing function is not used.
<input type="checkbox"/> Check that sensing wires or load cables are broken wires or have poor contact when the remote sensing function is used.	• Check that all cables and wires are connected correctly after turning off the POWER switch
<input type="checkbox"/> Check that the load current has peaks or is pulse-shaped.	• See 'Load' in "2.4 Load".
<input type="checkbox"/> Check that the variable resistor '1' on the control panel was moved.	• Internal reference voltage has been changed. Because re-adjustment is necessary, contact your Kikusui agent/distributor.



Unless otherwise specified, the specifications of the unit are based on the following conditions.

- The load is a pure resistance.
- The - (neg.) output terminal is connected to the ( $\perp$ ) chassis ground terminal with the supplied shorting bar.
- The unit should be used after 30 minutes warming-up time (with current flowing).

TYP value, standard value and theoretical value do not guarantee performance. They should be referred to as target values only.

## Common Specifications

Common Specifications	
Input	
Input voltage and frequency	230 V (217 V to 250V), 50/60 Hz, 1-phase, Crest factor: 1.2 to 1.41
Constant voltage operation indication	C.V, green LED indication
Constant current operation indication	C.C, red LED indication
Range of operation temperature and humidity	0 °C to 40 °C/10 % to 90 % RH (no dew condensation allowed)
Range of storage temperature and humidity	-10 °C to 60 °C/0 % to 90 % RH max. (no dew condensation allowed)
Cooling system	Forced air cooling with fan
Output polarity	Positive or negative grounding possible
Withstanding voltage	
Across input terminals and output terminals	Should withstand 1 500 V AC, 1 min. with no abnormalities
Across input terminals and chassis	
Remote sensing	Possible (compensation one way approx. 0.6 V max.)
Master-slave-control parallel operation	Possible
Electromagnetic Compatibility	Complies with the requirements of the following directive and standards EMC Directive 2004/108/EC EN 61326-1
Safety	Complies with the requirements of the following directive and standards Low Voltage Directive 2006/95/EC EN 61010-1, Class I, Pollution Degree 2

## Specifications of PAN-A Series Model 175W

Model 175W		PAN16-10A	PAN35-5A	PAN60-3A
<b>Input</b>				
	Power consumption, rated load	MAX 480 VA	MAX 480 VA	MAX 420 VA
<b>Output</b>				
Voltage	Rated voltage	16 V	35 V	60 V
	Variable range	0 V to 16V	0 V to 35V	0 V to 60V
	Resolution (theoretical value) *1	3 mV	7 mV	11 mV
	Number of turns of control knob	10 turns		
Current	Rated current	10 A	5 A	3 A
	Variable range	0 A to 10 A	0 A to 5 A	0 A to 3 A
	Resolution (theoretical value) *1	1.8 mA	0.9 mA	0.6 mA
	Number of turns of control knob	10 turns		
<b>Constant voltage characteristics</b>				
	Ripple and noise (5 Hz to 1 MHz) RMS	0.5 mV		
	Source effect (to $\pm 10$ % of AC input voltage)	0.005 % +1 mV		
	Load effect (to 0 % to 100 % of output current) *2	0.005 % +1 mV		
	Transient response (standard value) *2, *3	50 $\mu$ s		
	Temperature coefficient	100 ppm/ $^{\circ}$ C (TYP value)		

\*1 The value is calculated from the number of turns of the wire-wound potentiometer. In practice, use 3-5 times each value as a target.

\*2 Measured at the OUTPUT terminal board on the rear panel using the remote sensing function.

\*3 Time necessary for output voltage to return to  $\pm(0.05\%+10\text{ mV})$  max. of rated value at 5 % to 100 % changes of output current.

Model 175W		PAN16-10A	PAN35-5A	PAN60-3A
Constant current characteristics				
Ripple and noise (5 Hz to 1 M Hz) RMS		2 mA	1 mA	1 mA
Source effect (to $\pm 10$ % of AC input voltage)		1 mA		
Load effect (to approx. 1 V to 100 % of output voltage)		3 mA	2 mA	2 mA
Temperature coefficient		300 ppm/ $^{\circ}$ C (TYP value)		
Isolation		$\pm 250$ V		
Insulation resistance				
Across chassis and input terminals		500 VDC, 30 M $\Omega$ min. (measured at ambient humidity 70 % RH max.)		
Across chassis and output terminals		500 VDC, 20 M $\Omega$ min. (measured at ambient humidity 70 % RH max.)		
Meter display				
Output voltage	Max. figure displayed (fixed range)	19.99	199.9	199.9
	Display error	$\pm(0.5$ % of rdg <sup>*4</sup> +2 digits) at 23 $^{\circ}$ C $\pm 5$ $^{\circ}$ C		
	Temperature coefficient	300 ppm/ $^{\circ}$ C (TYP value)		
Output current	Max. figure displayed (fixed range)	19.99		
	Display error	$\pm(1$ % of rdg <sup>*4</sup> +5 digits) at 23 $^{\circ}$ C $\pm 5$ $^{\circ}$ C		
	Temperature coefficient	400 ppm/ $^{\circ}$ C (TYP value)		
Remote control				
Output voltage/ control voltage ratio		16 V/ approx. 10 V	35 V/ approx. 10 V	60 V/ approx. 10 V
Output voltage/ control resistance ratio		16 V/ approx. 10 k $\Omega$	35 V/ approx. 10 k $\Omega$	60 V/ approx. 10 k $\Omega$
Output current/ control voltage ratio		10 A/ approx. 10 V	5 A/ approx. 10 V	3 A/ approx. 10 V
Output current/ control resistance ratio		10 A/ approx. 10 k $\Omega$	5 A/ approx. 10 k $\Omega$	3 A/ approx. 10 k $\Omega$

\*4 rdg: Reading value of output voltage or output current.

Model 175W	PAN16-10A	PAN35-5A	PAN60-3A
Master-slave-control series operation	Possible		
Protective circuit			
Over-voltage protection (OVP) for output	Preset range: Approx. 10 % to 110 % of rated output voltage		
	ALM LED lights up, control transistor cut off and rectification circuit shut down when OVP tripped.		
Input fuse	5 A, 250 VAC		
Output fuse standard pre-arcing time-current type	15 A	7 A	4 A
Thermal fuse	Incorporated in transformer		
Weight	Approx.11 kg (24.3 lb)		
Dimensions	See outline drawing.		
Accessory			
Operation manual	1 copy		
Power cable	1 pc.		
Protection cover	Guard cap 2 pcs. Rear output terminal cover 1 pc. Front auxiliary output terminal cover 1 pc. (Mounting screw(M3 x 20) 1 pc.)		

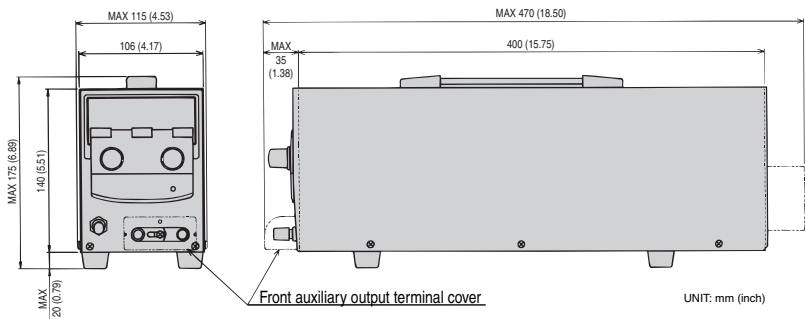

Fig.7-1 PAN-A Series Model 175W Outline Drawing

## Specifications of PAN-A Series Model 350W

Model 350W		PAN16-18A	PAN35-10A	PAN60-6A
<b>Input</b>				
Power consumption, rated load		MAX 900 VA	MAX 900 VA	MAX 800 VA
<b>Output</b>				
Voltage	Rated voltage	16 V	35 V	60 V
	Variable range	0 V to 16V	0 V to 35V	0 V to 60V
	Resolution (theoretical value) *5	3 mV	7 mV	11 mV
	Number of turns of control knob	10 turns		
Current	Rated current	18 A	10 A	6 A
	Variable range	0 A to 18 A	0 A to 10 A	0 A to 6 A
	Resolution (theoretical value) *5	3.3 mA	1.8 mA	1.1 mA
	Number of turns of control knob	10 turns		
<b>Constant voltage characteristics</b>				
Ripple and noise (5 Hz to 1 MHz) RMS		0.5 mV		
Source effect (to $\pm 10$ % of AC input voltage)		0.005 % + 1 mV		
Load effect (to 0 % to 100 % of output current) *6		0.005 % + 1 mV		
Transient response (standard value) *6, *7		50 $\mu$ s		
Temperature coefficient		100 ppm/ $^{\circ}$ C (TYP value)		

\*5 The value is calculated from the number of turns of the wire-wound potentiometer. In practice, use 3-5 times each value as a target.

\*6 Measured at the OUTPUT terminal board on the rear panel using the remote sensing function.

\*7 Time necessary for output voltage to return to  $\pm(0.05\% + 10\text{ mV})$  max. of rated value at 5 % to 100 % changes of output current.

Model 350W		PAN16-18A	PAN35-10A	PAN60-6A
Constant current characteristics				
Ripple and noise (5 Hz to 1 MHz) RMS		5 mA	2 mA	2 mA
Source effect (to $\pm 10$ % of AC input voltage)		1 mA		
Load effect (to approx. 1 V to 100 % of output voltage)		3 mA		
Temperature coefficient		300 ppm/ $^{\circ}$ C (TYP value)		
Isolation		$\pm 250$ V		
Insulation resistance				
Across chassis and input terminals		500 VDC, 30 M $\Omega$ min. (measured at ambient humidity 70 % RH max.)		
Across chassis and output terminals		500 VDC, 20 M $\Omega$ min. (measured at ambient humidity 70 % RH max.)		
Meter display				
Output voltage	Max. figure displayed (fixed range)	19.99	199.9	199.9
	Display error	$\pm(0.5$ % of rdg <sup>*8</sup> +2 digits) at 23 $^{\circ}$ C $\pm 5$ $^{\circ}$ C		
	Temperature coefficient	300 ppm/ $^{\circ}$ C (TYP value)		
Output current	Max. figure displayed (fixed range)	19.99		
	Display error	$\pm(1$ % of rdg <sup>*8</sup> +5 digits) at 23 $^{\circ}$ C $\pm 5$ $^{\circ}$ C		
	Temperature coefficient	400 ppm/ $^{\circ}$ C (TYP value)		
Remote control				
Output voltage/ control voltage ratio		16 V/ approx. 10 V	35 V/ approx. 10 V	60 V/ approx. 10 V
Output voltage/ control resistance ratio		16 V/ approx. 10 k $\Omega$	35 V/ approx. 10 k $\Omega$	60 V/ approx. 10 k $\Omega$
Output current/ control voltage ratio		18 A/ approx. 10 V	10 A/ approx. 10 V	6 A/ approx. 10 V
Output current/ control resistance ratio		18 A/ approx. 10 k $\Omega$	10 A/ approx. 10 k $\Omega$	6 A/ approx. 10 k $\Omega$

\*8 rdg: Reading value of output voltage or output current.

Model 350W	PAN16-18A	PAN35-10A	PAN60-6A
Master-slave-control series operation	Possible		
Protective circuit			
Over-voltage protection (OVP) for output	Preset range:    Approx. 10 % to 110 % of rated output voltage		
	ALM LED lights up, control transistor cut off and rectification circuit shut down when OVP tripped.		
Input fuse	8 A, 250 VAC		
Output fuse standard pre-arcing time-current type	30 A	15 A	10 A
Thermal fuse	Incorporated in transformer		
Weight	Approx.17 kg (37.5 lb)		
Dimensions	See outline drawing.		
Accessory			
Operation manual	1 copy		
Power cable	1 pc.		
Input fuse	1 pc.		
Protection cover	Guard cap 2 pcs. Rear output terminal cover 1 pc. Front auxiliary output terminal cover 1 pc. (Mounting screw(M3 x 20) 1 pc.)		

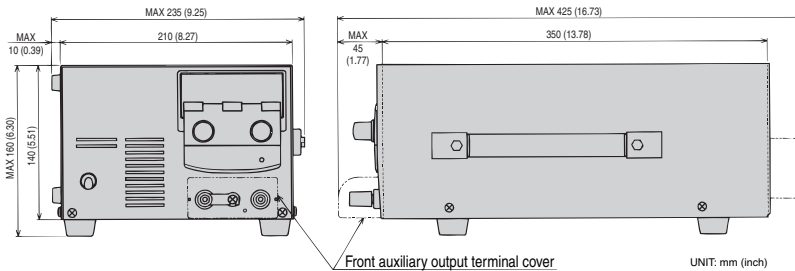

Fig.7-2 PAN-A Series Model 350W Outline Drawing



## Specifications of PAN-A Series Model 700W

Model 700W		PAN16-30A	PAN35-20A	PAN60-10A
<b>Input</b>				
	Power consumption, rated load	MAX 1300 VA	MAX 1650 VA	MAX 1300 VA
<b>Output</b>				
Voltage	Rated voltage	16 V	35 V	60 V
	Variable range	0 V to 16V	0 V to 35V	0 V to 60V
	Resolution (theoretical value) *9	3 mV	7 mV	11 mV
	Number of turns of control knob	10 turns		
Current	Rated current	30 A	20 A	10 A
	Variable range	0 A to 30 A	0 A to 20 A	0 A to 10 A
	Resolution (theoretical value) *9	5.4 mA	3.6 mA	1.8 mA
	Number of turns of control knob	10 turns		
<b>Constant voltage characteristics</b>				
	Ripple and noise (5 Hz to 1 MHz) RMS	0.5 mV		
	Source effect (to $\pm 10$ % of AC input voltage)	0.005 % +1 mV		
	Load effect (to 0 % to 100 % of output current) *10	0.005 % +2 mV		
	Transient response (standard value) *10, *11	50 $\mu$ s		
	Temperature coefficient	100 ppm/ $^{\circ}$ C (TYP value)		

\*9 The value is calculated from the number of turns of the wire-wound potentiometer. In practice, use 3-5 times each value as a target.

\*10 Measured at the OUTPUT terminal board on the rear panel using the remote sensing function.

\*11 Time necessary for output voltage to return to  $\pm(0.05\%+10\text{ mV})$  max. of rated value at 5 % to 100 % changes of output current.

Model 700W		PAN16-30A	PAN35-20A	PAN60-10A
Constant current characteristics				
Ripple and noise (5 Hz to 1 M Hz) RMS		5 mA	3 mA	3 mA
Source effect (to $\pm 10$ % of AC input voltage)		3 mA		
Load effect (to approx. 1 V to 100 % of output voltage)		3 mA		
Temperature coefficient		300 ppm/ $^{\circ}$ C (TYP value)		
Isolation		$\pm 250$ V		
Insulation resistance				
Across chassis and input terminals		500 VDC, 30 M $\Omega$ min. (measured at ambient humidity 70 % RH max.)		
Across chassis and output terminals		500 VDC, 20 M $\Omega$ min. (measured at ambient humidity 70 % RH max.)		
Meter display				
Output voltage	Max. figure displayed (fixed range)	19.99	199.9	199.9
	Display error	$\pm(0.5$ % of rdg* <sup>12</sup> +2 digits) at 23 $^{\circ}$ C $\pm 5$ $^{\circ}$ C		
	Temperature coefficient	300 ppm/ $^{\circ}$ C (TYP value)		
Output current	Max. figure displayed (fixed range)	199.9	199.9	19.99
	Display error	$\pm(1$ % of rdg* <sup>12</sup> +5 digits) at 23 $^{\circ}$ C $\pm 5$ $^{\circ}$ C		
	Temperature coefficient	400 ppm/ $^{\circ}$ C (TYP value)		
Remote control				
Output voltage/ control voltage ratio		16 V/ approx. 10 V	35 V/ approx. 10 V	60 V/ approx. 10 V
Output voltage/ control resistance ratio		16 V/ approx. 10 k $\Omega$	35 V/ approx. 10 k $\Omega$	60 V/ approx. 10 k $\Omega$
Output current/ control voltage ratio		30 A/ approx. 10 V	20 A/ approx. 10 V	10 A/ approx. 10 V
Output current/ control resistance ratio		30 A/ approx. 10 k $\Omega$	20 A/ approx. 10 k $\Omega$	10 A/ approx. 10 k $\Omega$

\*12 rdg: Reading value of output voltage or output current.

Model 700W	PAN16-30A	PAN35-20A	PAN60-10A
Master-slave-control series operation	Possible		
Protective circuit			
Over-voltage protection (OVP) for output	Preset range: Approx. 10 % to 110 % of rated output voltage		
	ALM LED lights up, control transistor cut off and rectification circuit shut down when OVP tripped.		
Input fuse	10 A, 250 VAC	15 A, 250 VAC	10 A, 250 VAC
Output fuse standard pre-arcing time-current type	30 A	30 A	15 A
Thermal fuse	Incorporated in transformer		
Weight	Approx.23 kg (50.7 lb)	Approx..23 kg (50.7 lb)	Approx.22 kg (48.5 lb)
Dimensions	See outline drawing.		
Accessory			
Operation manual	1 copy		
Power cable	1 pc.		
Input fuse	1 pc.		
Protection cover	Guard cap 2 pcs. Rear output terminal cover 1 pc. Front auxiliary output terminal cover 1 pc. (Mounting screw(M3 x 20) 1 pc.)		
Cable clamp	1 pc.		

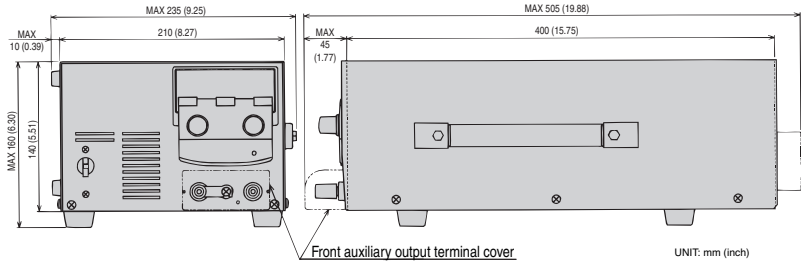

Fig.7-3 PAN-A Series Model 700W Outline Drawing



# INDEX

## Symbols

- - - - - 5-2  
+ - - - - 5-2

## A

AC IN - - - - - 5-7  
AC power code - - - - - 1-8  
Adjustment - - - - - 6-2  
ALM - - - - - 5-4  
Ammeter - - - - - 5-4  
Analog remote control - - - - - 4-8  
Auxiliary output terminals 2-2, 3-10,  
- - - - - 5-2

## C

CC - - - - - 3-7, 5-4  
CC power supply - - - - - 2-5  
Chassis ground terminal - - 5-2, 5-8  
Cleaning - - - - - 6-1  
Constant current power supply - 3-7  
Constant voltage power supply - 3-6  
CONTROL - - - - - 5-8  
CONTROL terminal board - - - - 4-1  
Cover - - - - - 3-13  
CURRENT - - - - - 5-3  
CV - - - - - 3-6, 5-5  
CV power supply - - - - - 2-5

## E

Exhaust port - - - - - 5-7  
External contact points - - - - - 4-22  
External resistor - - - - - 4-10, 4-16  
External voltage - - - - - 4-12, 4-18

## F

Front sub-panel cover - - - - - 5-5  
FUSE - - - - - 5-7  
Fuse - - - - - 1-7

## G

Grounding - - - - - 1-10  
Guard caps - - - - - 3-14

## I

Inrush current - - - - - 2-1  
Inspection - - - - - 6-1

## L

LIMIT - - - - - 5-3  
Load - - - - - 2-2, 3-8

## M

Malfunction - - - - - 6-9  
Master-slave-control  
    Parallel operation - - - - - 4-24  
    series operation - - - - - 4-30

## N

Negative voltage - - - - - 2-1

## O

OUTPUT - - - - - 5-3, 5-8  
OUTPUT terminal board - - - - - 3-11  
Over Voltage Protection - - - - - 3-4  
OVP - - - - - 5-4  
OVP trip point - - - - - 3-4

## P

Packing -----1-4  
POWER -----5-2  
POWER switch -----3-2  
PRESET OVP -----5-3

## R

Rack mounting -----P-3  
Remote control -----4-8  
Remote sensing -----4-5

## S

SENS -----5-8  
Shorting bar -----5-2

## T

Turning on the power -----3-1

## V

Voltmeter -----5-4



**KIKUSUI ELECTRONICS CORPORATION**

1-1-3, HIGASHIYAMATA, TSUZUKI-KU, YOKOHAMA, 224-0023, JAPAN  
TEL: (045) 593-7570, FAX: (045) 593-7571

APP No. : ECE58004

TD No. : CE-0097

## Declaration of Conformity

Equipment name: PAN16-10A, PAN35-5A, PAN60-3A, PAN16-18A, PAN35-10A, PAN60-6A  
PAN16-30A, PAN35-20A, PAN60-10A

Description of Equipment: Regulated DC Power Supply

Manufacturer: Kikusui Electronics Corporation

Manufacturer's address: 1-1-3 Higashiyamata, Tsuzuki-ku, Yokohama, 224-0023, Japan

### Applicable Standards

Including level & class where appropriate:

Safety: EN61010-1:2001

EMC: EN61326-1:2006

Emission: Class A

Immunity: Basic immunity test requirements

We certify that equipment identified above conforms to the requirements of Council Directive 2006/95/EC and 2004/108/EC.

The last two digit of the year in which the CE marking was affixed for Low Voltage Directive 2006/95/EC, is 09

Manufacturer:

Authorized Representative:

Signed: M. Magome

Signed: R.V. Lovell

M. Magome  
Executive Officer

R.V. Lovell  
Managing Director

Date: 16. Mar 2009

Date: 24th March 2009

For and on behalf of  
Kikusui Electronics Corporation

For and on behalf of  
Telonic Instruments Limited  
Toutley Industrial Estate, Toutley Road,  
Wokingham, Berkshire, RG41 1QN,  
United Kingdom

\* CE marked products for the PAN-A series are specified on the cover page of this operation manual.

