

**High Performance DC Power Supplies** speed and accuracy for test optimization

## Single-Output 200 W GPIB

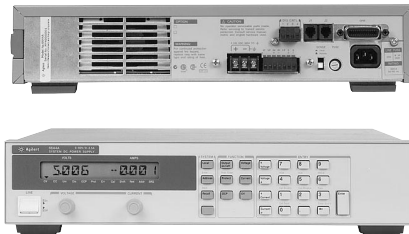

6641A - 6645A

- Fast, low-noise outputs
- Analog control of output voltage and current
- Fan-speed control to minimize acoustic noise
- Parallel and series connections of multiple units
- Built-in measurements and advanced programmable features
- Protection features to ensure DUT safety

### Specifications

(at 0° to 55° C unless otherwise specified)

	6641A	6642A	6643A	6644A	6645A
<b>Number of outputs</b>	1	1	1	1	1
<b>GPIB</b>	Yes	Yes	Yes	Yes	Yes
<b>Output ratings</b>					
Output voltage	0 to 8 V	0 to 20 V	0 to 35 V	0 to 60 V	0 to 120 V
Output current (40° C)	0 to 20 A	0 to 10 A	0 to 6 A	0 to 3.5 A	0 to 1.5 A
Maximum current (50° C/55° C)	18 A/17 A	9 A/8.5 A	5.4 A/5.1 A	3.2 A/3 A	1.4 A/1.3 A
<b>Programming accuracy at 25°C ±5°C</b>					
Voltage	0.06% + 5 mV	10 mV	15 mV	26 mV	51 mV
Current	0.15% + 26 mA	13 mA	6.7 mA	4.1 mA	1.7 mA
<b>Ripple and noise from 20 Hz to 20 MHz</b>					
Voltage	rms 300 µV	300 µV	400 µV	500 µV	700 µV
	peak-peak 3 mV	3 mV	4 mV	5 mV	7 mV
Current	rms 10 mA	5 mA	3 mA	1.5 mA	1 mA
<b>Readback accuracy at 25°C ±5°C (percent of reading plus fixed)</b>					
Voltage	0.07% + 6 mV	15 mV	25 mV	40 mV	80 mV
+Current	0.15% + 18 mA	9.1 mA	5 mA	3 mA	1.3 mA
-Current	0.35% + 40 mA	20 mA	12 mA	6.8 mA	2.9 mA
<b>Load regulation</b>					
Voltage	1 mV	2 mV	3 mV	4 mV	5 mV
Current	1 mA	0.5 mA	0.25 mA	0.25 mA	0.25 mA
<b>Line regulation</b>					
Voltage	0.5 mV	0.5 mV	1 mV	1 mV	2 mV
Current	1 mA	0.5 mA	0.25 mA	0.25 mA	0.25 mA
<b>Transient response time</b> Less than 100 µs for the output voltage to recover to its previous level (within 0.1% of the voltage rating of the supply or 20 mV, whichever is greater) following any step change in load current of up to 50% of rated current					
<b>Supplemental Characteristics</b> (Non-warranted characteristics determined by design and useful in applying the product)					
<b>Average resolution</b>					
Voltage	2 mV	5 mV	10 mV	15 mV	30 mV
Current	6 mA	3 mA	2 mA	1.2 mA	0.5 mA
OVP	13 mV	30 mV	54 mV	93 mV	190 mV
<b>OVP accuracy</b>	160 mV	400 mV	700 mV	1.2 V	2.4 V

This series of 200 W linear-regulated DC power supplies is designed to maximize the throughput of DUTs through the manufacturing test process with fast up and down programming time.

Valuable assemblies can be destroyed by a minor component failure that can allow a surge of voltage or current to flow to the DUT. Fast protection features, including fast crowbar, mode crossover protection, and the ability to connect the protection circuitry of multiple power supplies can increase production yield.

Programming of the DC output and the protection features can be done either from the front panel or using industry standard SCPI commands, via the GPIB. Using the serial link, up to 16 power supplies can be connected through one GPIB address. Test system integration can be further simplified by using the VXIPlug&Play drivers. The output voltage and current can also be controlled with analog signals. This is helpful for certain types of noisy environments, and also immediate reactions to process changes.

Lab bench use is enhanced by the fan speed control, which helps to minimize the acoustic noise.

## Single-Output: 200 W GPIB (Continued)

**Application Notes:**

**10 Practical Tips You Need to Know About Your Power Products**  
5965-8239E

**10 Hints for Using Your Power Supply to Decrease Test Time**  
5968-6359E

**Understanding Linear Power Supply Operation (AN1554)**  
5989-2291EN

**Modern Connectivity - Using USB and LAN I/O Converters (AN 1475-1)**  
5989-0123EN

**Supplemental Characteristics for all model numbers**

**DC Floating Voltage:** Output terminals can be floated up to ±240 Vdc from chassis ground

**Remote Sensing:** Up to half the rated output voltage can be dropped in each load lead. The drop in the load leads subtracts from the voltage available for the load.

**Command Processing Time:** Average time required for the output voltage to begin to change following receipt of digital data is 20 ms for the power supplies connected directly to the GPIB

**Output Programming Response Time:** The rise and fall time (10/90% and 90/10%) of the output voltage is less than 15 ms. The output voltage change settles within 1 LSB (0.025% x rated voltage) of final value in less than 60 ms.

**Down Programming:** An active down programmer sinks approximately 20% of the rated output current

**Modulation:** (Analog programming of output voltage and current)  
Input Signal: 0 to -5 V  
Input Impedance: 10 k Ohm nominal

Specifications (at 0° to 55° C unless otherwise specified)	6641A-J04 Special Order Option	6643A-J11 Special Order Option	6644A-J09 Special Order Option	6645A-J05 Special Order Option	6645A-J06 Special Order Option
<b>Number of Outputs</b>	1	1	1	1	1
<b>GPIB</b>	Yes	Yes	Yes	Yes	Yes
<b>Output ratings</b>					
Output voltage	13 V	40 V	70 V	150 V	170 V
Output current (40°C)	15.3 A	5 A	3 A	1.2 A	1 A
Maximum current (50°C/55°C)	13.77 A/13 A	4.5 A/4.25 A	2.7 A/2.55 A	1.08 A/1.02 A	0.9 A/0.85 A
<b>Programming accuracy at 25°C ±5°C</b>					
Voltage	0.06% +	8.5 mV	17.5 mV	31 mV	65 mV
Current	0.15% +	21 mA	6.7 mA	4.1 mA	1.7 mA
<b>Ripple and noise</b>					
from 20 Hz to 20 MHz					
Voltage	rms	300 µV	450 µV	600 µV	900 µV
	peak-peak	3 mV	3.5 mV	6 mV	9 mV
	Current rms	8 mA	3 mA	1.5 mA	1 mA
<b>Readback accuracy at 25°C ±5°C (percent of reading plus fixed)</b>					
Voltage	0.07% +	10 mV	30 mV	47 mV	100 mV
+Current	0.15% +	15 mA	5 mA	3 mA	1.3 mA
-Current	0.35% +	40 mA	12 mA	6.8 mA	2.9 mA
<b>Load regulation</b>					
Voltage		1 mV	3 mV	4.5 mV	7 mV
Current		1 mA	0.25 mA	0.25 mA	0.25 mA
<b>Line regulation</b>					
Voltage		0.5 mV	1 mV	1.5 mV	2.5 mV
Current		1 mA	0.25 mA	0.25 mA	0.25 mA
<b>Transient response time</b> Less than 100 µs for the output voltage to recover to its previous level (within 0.1% of the voltage rating of the supply or 20 mV, whichever is greater) following any step change in load current of up to 50% of rated current					
<b>Supplemental Characteristics</b> (Non-warranted characteristics determined by design and useful in applying the product)					
<b>Average resolution</b>					
Voltage		3.5 mV	12 mV	1.4 mV	37.5 mV
Current		5 mA	2 mA	1.2 mA	0.5 mA
OVP		23 mV	62 mV	110 mV	250 mV
<b>OVP accuracy</b>		260 mV	800 mV	1.5 mV	3 V

## Single-Output: 200 W GPIB (Continued)

**AC Input:** (AC input frequency 47 to 63 Hz)

**Voltage** 100 Vac 120 Vac 220 Vac 240 Vac  
**Current** 4.4 A 3.8 A 2.2 A 2.0 A

**Input Power** 480 VA, 400 W at full load;  
 60 W at no load

**GPIB Interface Capabilities** SH1, AH1, T6, L4, SR1, RL1, PP0, DC1, DT1, E1, and C0. IEEE-488.2 and SCPI-compatible command set

**Software Driver:**

- IVI-COM
- VXIPlug&Play

**Regulatory Compliance:** Complies with UL 3111-1, IEC 61010-1.

**Size:** 425.5 mm W x 88.1 mm H x 439 mm D (16.75 in x 3.5 in x 17.3 in)

**Weight:** Net, 14.2 kg (31.4 lb); shipping, 16.3 kg (36 lb)

**Warranty Period:** One year

### Ordering Information

- Opt 100** 87 to 106 Vac, 47 to 63 Hz
  - Opt 120** 104 to 127 Vac, 47 to 63 Hz
  - Opt 220** 191 to 233 Vac, 47 to 63 Hz
  - Opt 240** 209 to 250 Vac, 47 to 63 Hz
  - \* **Opt 908** Rack-mount Kit (p/n 5063-9212)
  - \* **Opt 909** Rack-mount Kit w/ Handles (p/n 5063-9219)
  - \* **Opt 1CP** Rack-mount Kit with Handles, p/n 5063-9219
  - Opt 0L1** Full documentation on CD-ROM, and printed standard documentation package
  - Opt 0L2** Extra copy of standard printed documentation package
  - Opt 0B0** Full documentation on CD-ROM only
  - Opt 0B3** Service Manual
- \* Support rails required

### Accessories

- p/n **1494-0060** Accessory Slide Kit
- p/n **1252-3698** 7-pin Analog Plug
- p/n **1252-1488** 4-pin Digital Plug
- p/n **5080-2148** Serial Link Cable 2 m (6.6 ft)
- E3663AC** Support rails for Agilent rack cabinets

**Agilent Models: 6641A, 6642A, 6643A, 6644A, 6645A**

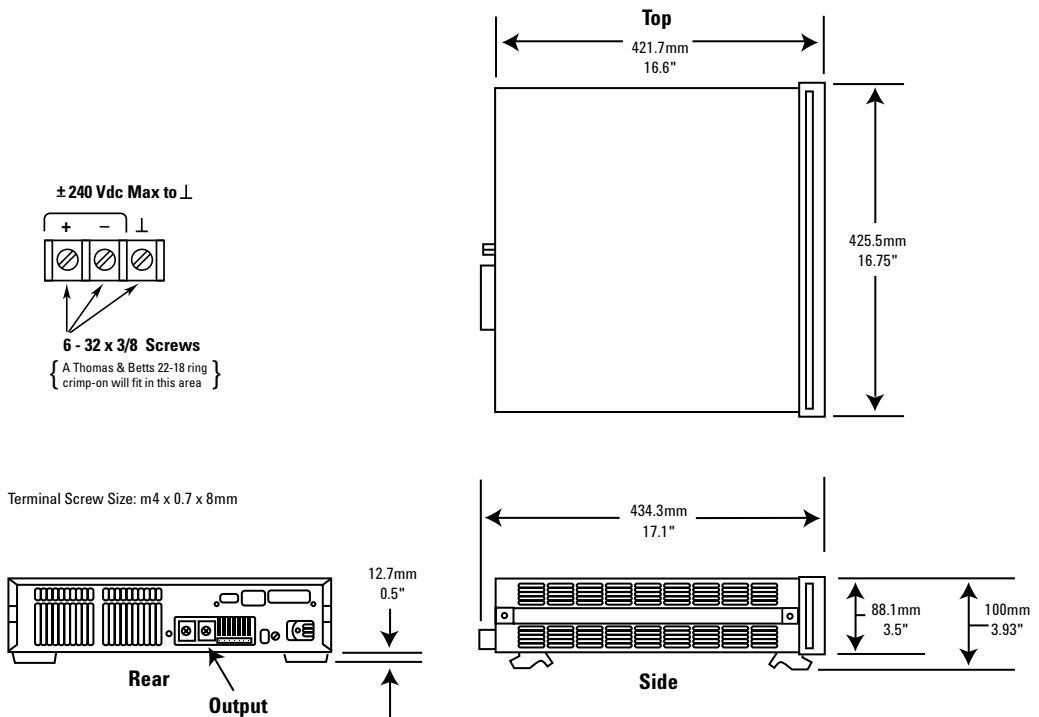

More detailed specifications at [www.agilent.com/find/6640](http://www.agilent.com/find/6640)

**Your Requested Excerpt from the  
Agilent System and Bench Instruments Catalog 2006**

The preceding page(s) are an excerpt from the 2006 System and Bench Instruments Catalog. We hope that these pages supply the information that you currently need. If you would like to have further information about the extensive selection of Agilent DC power supplies, please visit [www.agilent.com/find/power](http://www.agilent.com/find/power) to print a copy of the complete catalog, or to request that a copy be sent to you. You will also find a lot of other useful information on this Web site.

In the full System and Bench Instruments Catalog, you will find that Agilent offers much more than DC power supplies. This catalog contains detailed technical and application information on digital multimeters, DC power supplies, arbitrary waveform generators, and many more instruments. If you need basic, clean, power for your lab bench, it's there. In each power product category we have also integrated the capabilities you need for a complete power solution, including extensive measurement and analysis capabilities.

Please give us a call at your local Agilent Technologies sales office, or call a regional office listed, for assistance in choosing or using Agilent power products.

**Keep up to date with Agilent's Test and Measurement Email Updates**

As an Email Update subscriber, you will receive periodic customized email updates that match the areas of interest that you have specified. Your update will include products and services, applications and support information, events and promotions. Sign up today at [www.agilent.com/find/emailupdates](http://www.agilent.com/find/emailupdates). Check off DC power supplies, AC power sources or electronic loads on your registration form, and we will promptly let you know what's new in power products. Our Privacy Statement at [www.agilent.com/go/privacy](http://www.agilent.com/go/privacy) describes our commitment to you regarding your privacy.

**[www.agilent.com](http://www.agilent.com)**

**For more information on Agilent Technologies' products, applications or services, please contact your local Agilent office. The complete list is available at:**

[www.agilent.com/find/contactus](http://www.agilent.com/find/contactus)

**Phone or Fax**

**United States:**

(tel) 800 829 4444  
(fax) 800 829 4433

**Canada:**

(tel) 877 894 4414  
(fax) 800 746 4866

**China:**

(tel) 800 810 0189  
(fax) 800 820 2816

**Europe:**

(tel) 31 20 547 2111

**Japan:**

(tel) (81) 426 56 7832  
(fax) (81) 426 56 7840

**Korea:**

(tel) (080) 769 0800  
(fax) (080) 769 0900

**Latin America:**

(tel) (305) 269 7500

**Taiwan:**

(tel) 0800 047 866  
(fax) 0800 286 331

**Other Asia Pacific Countries:**

(tel) (65) 6375 8100  
(fax) (65) 6755 0042  
Email: [tm\\_ap@agilent.com](mailto:tm_ap@agilent.com)  
Contacts revised: 09/26/05

Product specifications and descriptions in this document subject to change without notice.

© Agilent Technologies, Inc. 2006  
Printed in the USA, February 8, 2006