



**Advanced Test Equipment Rentals**  
**www.atecorp.com 800-404-ATEC (2832)**



**Sorensen**  
**ASD Series**  
**Programmable**  
**Precision High Power**  
**DC Power Supply**

DAVINCI POWER™ ENABLED

*Operation, Programming and  
Maintenance Manual*







## **About AMETEK**

AMETEK Programmable Power, Inc., a Division of AMETEK, Inc., is a global leader in the design and manufacture of precision, programmable power supplies for R&D, test and measurement, process control, power bus simulation and power conditioning applications across diverse industrial segments. From bench top supplies to rack-mounted industrial power subsystems, AMETEK Programmable Power is the proud manufacturer of Elgar, Sorensen, California Instruments and Power Ten brand power supplies.

AMETEK, Inc. is a leading global manufacturer of electronic instruments and electromechanical devices with annualized sales of \$2.5 billion. The Company has over 11,000 colleagues working at more than 80 manufacturing facilities and more than 80 sales and service centers in the United States and around the world.

## **Trademarks**

AMETEK is a registered trademark of AMETEK, Inc.

Other trademarks, registered trademarks, and product names are the property of their respective owners and are used herein for identification purposes only.

## **Notice of Copyright**

*ASD Series Programmable Precision High Power DC Power Supply Operation, Programming and Maintenance Manual* © 2012 AMETEK Programmable Power, Inc. All rights reserved.

## **Exclusion for Documentation**

UNLESS SPECIFICALLY AGREED TO IN WRITING, AMETEK PROGRAMMABLE POWER, INC. ("AMETEK"):

- (a) MAKES NO WARRANTY AS TO THE ACCURACY, SUFFICIENCY OR SUITABILITY OF ANY TECHNICAL OR OTHER INFORMATION PROVIDED IN ITS MANUALS OR OTHER DOCUMENTATION.
- (b) ASSUMES NO RESPONSIBILITY OR LIABILITY FOR LOSSES, DAMAGES, COSTS OR EXPENSES, WHETHER SPECIAL, DIRECT, INDIRECT, CONSEQUENTIAL OR INCIDENTAL, WHICH MIGHT ARISE OUT OF THE USE OF SUCH INFORMATION. THE USE OF ANY SUCH INFORMATION WILL BE ENTIRELY AT THE USER'S RISK, AND
- (c) REMINDS YOU THAT IF THIS MANUAL IS IN ANY LANGUAGE OTHER THAN ENGLISH, ALTHOUGH STEPS HAVE BEEN TAKEN TO MAINTAIN THE ACCURACY OF THE TRANSLATION, THE ACCURACY CANNOT BE GUARANTEED. APPROVED AMETEK CONTENT IS CONTAINED WITH THE ENGLISH LANGUAGE VERSION, WHICH IS POSTED AT [WWW.PROGRAMMABLEPOWER.COM](http://WWW.PROGRAMMABLEPOWER.COM).

## **Date and Revision**

June 2012 Revision 01

## **Part Number**

M551177-01



## **Contact Information**

Telephone: 800 733 5427 (toll free in North America)  
858 450 0085 (direct)  
Fax: 858 458 0267  
Email: [sales@programmablepower.com](mailto:sales@programmablepower.com)  
[service@programmablepower.com](mailto:service@programmablepower.com)  
Web: [www.programmablepower.com](http://www.programmablepower.com)

This page intentionally left blank.

# IMPORTANT SAFETY INSTRUCTIONS

Before applying power to the system, verify that your product is configured properly for your particular application.

 <b>WARNING</b>	Hazardous voltages may be present when covers are removed. Qualified personnel must use extreme caution when servicing this equipment. Circuit boards, test points, and output voltages also may be floating above (below) chassis ground.
 <b>WARNING</b>	The equipment used contains ESD sensitive ports. When installing equipment, follow ESD Safety Procedures. Electrostatic discharges might cause damage to the equipment.

Only *qualified personnel* who deal with attendant hazards in power supplies, are allowed to perform installation and servicing.

Ensure that the AC power line ground is connected properly to the Power Rack input connector or chassis. Similarly, other power ground lines including those to application and maintenance equipment *must* be grounded properly for both personnel and equipment safety.

Always ensure that facility AC input power is de-energized prior to connecting or disconnecting any cable.

In normal operation, the operator does not have access to hazardous voltages within the chassis. However, depending on the user's application configuration, **HIGH VOLTAGES HAZARDOUS TO HUMAN SAFETY** may be normally generated on the output terminals. The customer/user must ensure that the output power lines are labeled properly as to the safety hazards and that any inadvertent contact with hazardous voltages is eliminated.

Guard against risks of electrical shock during open cover checks by not touching any portion of the electrical circuits. Even when power is off, capacitors may retain an electrical charge. Use safety glasses during open cover checks to avoid personal injury by any sudden component failure.

Neither AMETEK Programmable Power Inc., San Diego, California, USA, nor any of the subsidiary sales organizations can accept any responsibility for personnel, material or inconsequential injury, loss or damage that results from improper use of the equipment and accessories.

## SAFETY SYMBOLS



**WARNING:** Electrical Shock Hazard



**HAZARD:** Strong oxidizer



**GENERAL WARNING/CAUTION:** Read the accompanying message for specific information.



**BURN HAZARD:** Hot Surface Warning. Allow to cool before servicing.



**Do Not Touch:** Touching some parts of the instrument without protection or proper tools could result in damage to the part(s) and/or the instrument.



**Technician Symbol:** All operations marked with this symbol are to be performed by qualified maintenance personnel only.



**Electrical Ground:** This symbol inside the instrument marks the central safety grounding point for the instrument.

This page intentionally left blank.



## Product Family: ASD Series Programmable Precision High Power DC Power Supply

**Warranty Period:** Two (2) years

### WARRANTY TERMS

AMETEK Programmable Power, Inc. (“AMETEK”), provides this written warranty covering the Product stated above, and if the Buyer discovers and notifies AMETEK in writing of any defect in material or workmanship within the applicable warranty period stated above, then AMETEK may, at its option: repair or replace the Product; or issue a credit note for the defective Product; or provide the Buyer with replacement parts for the Product.

The Buyer will, at its expense, return the defective Product or parts thereof to AMETEK in accordance with the return procedure specified below. AMETEK will, at its expense, deliver the repaired or replaced Product or parts to the Buyer. Any warranty of AMETEK will not apply if the Buyer is in default under the Purchase Order Agreement or where the Product or any part thereof:

- is damaged by misuse, accident, negligence or failure to maintain the same as specified or required by AMETEK;
- is damaged by modifications, alterations or attachments thereto which are not authorized by AMETEK;
- is installed or operated contrary to the instructions of AMETEK;
- is opened, modified or disassembled in any way without AMETEK’s consent; or
- is used in combination with items, articles or materials not authorized by AMETEK.

The Buyer may not assert any claim that the Products are not in conformity with any warranty until the Buyer has made all payments to AMETEK provided for in the Purchase Order Agreement.

### PRODUCT RETURN PROCEDURE

Request a Return Material Authorization (RMA) number from the repair facility (**must be done in the country in which it was purchased**):

- **In the USA**, contact the AMETEK Repair Department prior to the return of the product to AMETEK for repair, or submit your request on our website, [www.programmablepower.com](http://www.programmablepower.com) and click Support>RMAs.

Telephone: 800-733-5427, ext. 2295 or ext. 2463 (toll free North America)  
858-450-0085, ext. 2295 or ext. 2463 (direct)

- **Outside the United States**, contact the nearest Authorized Service Center (ASC). A full listing can be found either through your local distributor or our website, [www.programmablepower.com](http://www.programmablepower.com), by clicking Support and going to the Service Centers tab.

When requesting an RMA, have the following information ready:

- Model number
- Serial number
- Description of the problem

**NOTE:** Unauthorized returns will not be accepted and will be returned at the shipper’s expense.

**NOTE:** A returned product found upon inspection by AMETEK, to be in specification is subject to an evaluation fee and applicable freight charges.

This page intentionally left blank.

## **FCC NOTICE**

This equipment has been tested and found to comply with the limits for a Class A digital device, pursuant to part 15 of the FCC Rules. These limits are designed to provide reasonable protection against harmful interference when the equipment is operated in a commercial environment. This equipment generates, uses, and can radiate radio frequency energy and, if not installed and used in accordance with the instruction manual, may cause harmful interference to radio communications. Operation of this equipment in a residential area is likely to cause harmful interference in which case the user will be required to correct the interference at his own expense.

## ABOUT THIS MANUAL

This manual has been written expressly for the Sorensen ASD Series of power supplies that have been designed and certified to meet the Low Voltage and Electromagnetic Compatibility Directive Requirements of the European Community.

These models have been designed and tested to meet the Electromagnetic Compatibility directive (European Council directive 2004/108/EC; generally referred to as the EMC directive) and to the requirements of the Low Voltage directive (European Council directive 2006/95/EC, 93/68/EEC, dated 22 July 1993). In addition these models have been found compliant with FCC 47 CFR Part 15, Subpart B 107(e) Class A, 109(g) Class A.

Since the Low Voltage Directive is to ensure the safety of the equipment operator, universal graphic symbols have been used both on the unit itself and in this manual to warn the operator of potentially hazardous situations (see Safety Notice page).

# CONTENTS

## **SECTION 1 OVERVIEW ..... 1-21**

1.1	General Description.....	1-21
1.2	Specifications .....	1-22
1.2.1	Environmental Characteristics .....	1-22
1.2.2	Electrical Characteristics .....	1-23
1.2.3	Physical Characteristics.....	1-24

## **SECTION 2 INSTALLATION ..... 2-25**

2.1	Inspection.....	2-25
2.2	Contents of Shipment.....	2-25
2.3	Location and Mounting .....	2-26
2.3.1	Rack.....	2-26
2.3.2	Chassis Removal from Rack .....	2-27
2.4	Coolant Connections .....	2-27
2.4.1	Water Quality .....	2-27
2.5	Input/Output Electrical Connections.....	2-28
2.5.1	Isolated Analog Interface Connections .....	2-29
2.5.2	External Switches .....	2-31
2.6	Wire selection.....	2-33
2.6.1	Wire Size.....	2-33
2.7	Load Considerations .....	2-35
2.7.1	Inductive Loads.....	2-35
2.8	Outline Drawings .....	2-36
2.9	Installation Drawings .....	2-38

## **SECTION 3 OPERATION..... 3-1**

3.1	Introduction .....	3-1
3.2	Front Panel.....	3-1

3.3	Digital Operation .....	3-2
3.3.1	Floating and Polarized Output.....	3-2
3.3.2	Initial Setup.....	3-2
3.3.3	Voltage Mode Operation .....	3-3
3.3.4	Current Mode Operation .....	3-4
3.3.5	Analog Control Connector (J1).....	3-5
3.4	Remote Current Programming .....	3-6
3.4.1	Remote Current Programming Using a 4-20mA current source .....	3-6
3.4.2	Remote Current Programming Using a 0-10 VDC Voltage Source .....	3-7
3.5	Remote Voltage Programming.....	3-9
3.5.1	External Voltage Programming Using a 4-20mA current source .....	3-9
3.5.2	External Voltage Programming Using a 0-10 VDC Voltage Source .....	3-11
3.6	Remote power programming .....	3-13
3.6.1	External power Programming Using a 4-20mA current source .....	3-13
3.6.2	External POWER Programming Using a 0-10 VDC Voltage Source .....	3-14
3.7	Remote Sensing .....	3-14
3.8	Remote Output ON/OFF Control .....	3-15
3.8.1	Remote Output ON/OFF by Contact Closure .....	3-15
3.9	Parallel and Series Operation .....	3-17
3.9.1	Parallel Operation.....	3-17
3.9.2	Parallel Operation with an ASD Unit and an SGA Unit .....	3-18
3.9.3	Series Operation .....	3-20

## **SECTION 4 PROGRAMMING: DIGITAL INTERFACE CONTROL.....4-1**

4.1	Introduction.....	4-1
4.1.1	Features .....	4-1
4.1.2	Functions.....	4-1
4.2	Command Registers .....	4-2
4.2.1	Read/Write Registers .....	4-2
4.2.2	Read Only Registers .....	4-3
4.2.3	Command Write Registers .....	4-3
4.3	Advanced Digital Control Features .....	4-5
4.3.1	Setpoints .....	4-5
4.3.2	Remote Voltage Sensing .....	4-5
4.3.3	Load Impedance Monitor .....	4-5
4.3.4	Default Register Saving .....	4-6
4.3.5	Modbus Timeout.....	4-6
4.3.6	Flight Data Recorder (FDR) .....	4-7
4.3.7	Programmable Fault Behavior .....	4-9
4.3.8	External Process Control .....	4-9
4.3.9	Programmable Full-Scale Setting .....	4-10

4.3.10	Querying Module Information .....	4-10
4.3.11	Programmable Slew-Rate Limit .....	4-11
4.3.12	Programmable Low-Pass-Filters .....	4-11
4.3.13	Expected Number of Modules Feature .....	4-12
4.4	List of Registers.....	4-12
4.5	MODBUS Communications .....	4-20
4.5.1	Ethernet – Modbus-TCP .....	4-21
4.5.2	Serial – Modbus-RTU .....	4-21
4.5.3	Ethernet/IP Interface .....	4-22
4.5.4	EtherCAT Interface .....	4-23
4.5.5	Supervisory fault codes .....	4-26
4.6	MODBUS Control User Interface.....	4-28
4.6.1	Making a Connection .....	4-28
4.6.2	Ending a Connection .....	4-33
4.6.3	Settings Menu .....	4-34
4.6.4	View Menu .....	4-36
4.6.5	Master Controls Page .....	4-47
4.6.6	Configuration Page .....	4-51
4.6.7	Advanced Settings Page .....	4-53

## **SECTION 5 MAINTENANCE ..... 5-1**

5.1	Introduction .....	5-1
5.2	Preventive Maintenance .....	5-1
5.3	Fuses .....	5-3

## **LIST OF TABLES**

Table 2-1.	Analog Interface Signals. Standard ASD Pin-out (DB25) .....	2-29
Table 2-2.	Analog Interface Signals. SG-compatible Pin-out (DB25).....	2-30
Table 2-3.	Pin-out of the Reduced Analog Interface Connector (DB9) .....	2-30
Table 2-4.	Input/Output Connectors .....	2-32
Table 2-5.	Input Connections .....	2-32
Table 2-6.	Output Connections .....	2-32
Table 2-8.	Minimum Wire Size .....	2-33
Table 2-9.	Wire Resistance and Voltage Drop .....	2-34
Table 2-10.	Recommended Lugs .....	2-35
Table 2-12.	Recommended Sense Connector Tools.....	2-35
Table 4-1.	Master Controller FDR Data.....	4-7
Table 4-2.	Module Controller FDR Data .....	4-8
Table 4-3.	Module Data Query Commands.....	4-11
Table 4-4.	Write Registers .....	4-13
Table 4-5.	Command Register Bits .....	4-15

Table 4-6. FDR\_Period Register Bits ..... 4-16

Table 4-7. Process\_Config Register Bits ..... 4-16

Table 4-8. EtherCAT\_Config Register Bit ..... 4-16

Table 4-9. Read Registers ..... 4-17

Table 4-10. Status Register Bits ..... 4-19

Table 4-11. Fault\_Bits Register ..... 4-19

Table 4-12. Module\_Information Register Bits ..... 4-20

Table 4-13. Pin-out of the RJ45 Serial Port ..... 4-21

Table 4-14. Registers Available at the EtherCAT Interface ..... 4-23

Table 4-15. Commands Bits Required for EtherCAT Operation ..... 4-24

Table 4-16. EtherCAT PDOs and Variables ..... 4-25

Table 4-17. Master Supervisory Fault Codes ..... 4-26

Table 4-18. Module Supervisory Fault Codes ..... 4-27

Table 4-19. Settings Menu Selections ..... 4-34

Table 5-1. Recommended Annual Inspection ..... 5-2

**LIST OF FIGURES**

Figure 1-1. Model Number Decoding ..... 1-21

Figure 2-1. Rear Panel Coolant Connectors ..... 2-27

Figure 2-2. Rear Panel Connections: Analog Interface ..... 2-28

Figure 2-3. Rear Panel Connections: EtherCAT Interface ..... 2-28

Figure 2-4. Diode Connection ..... 2-36

Figure 2-5. ASD Dimensions, Front View ..... 2-36

Figure 2-6. ASD Dimensions, Top View ..... 2-37

Figure 2-7. Slide Rack Mounting Holes ..... 2-38

Figure 2-8. Rear Panel AC Connectors ..... 2-38

Figure 2-9. Rear Panel Bus Bar Connectors ..... 2-39

Figure 3-1. Status LEDs ..... 3-1

Figure 3-2. ANALOG CONTROL Connector (J1) Pin-out ..... 3-5

Figure 3-3. Remote Current Programming Using Current Source (Digital Option Board) ..... 3-6

Figure 3-4. Remote Current Programming Using Current Source (SG compatible Option Board) ..... 3-7

Figure 3-5. Remote Current Programming Using Current Source (EtherCAT Option Board) ..... 3-7

Figure 3-6. Remote Current Programming Using 0-10 VDC Voltage Source (Digital Option Board) ..... 3-8

Figure 3-7. Remote Current Programming Using 0-10 VDC Voltage Source (SG compatible Option Board) ..... 3-8

Figure 3-8. Remote Current Programming Using 0-10 VDC Voltage Source (EtherCAT Option Board) ..... 3-8



Figure 3-9. Remote Voltage Programming Using Current Source (Digital Option Board) .....	3-9
Figure 3-10. Remote Voltage Programming Using Current Source (SG compatible Option Board) .....	3-10
Figure 3-11. Remote Voltage Programming Using Current Source (EtherCAT Option Board).....	3-10
Figure 3-12. Remote Voltage Programming Using 0-10 VDC Voltage Source (Digital Option Board) .....	3-11
Figure 3-13. Remote Voltage Programming Using 0-10 VDC Voltage Source (SG compatible Option Board) .....	3-11
Figure 3-14. Remote Voltage Programming Using 0-10 VDC Voltage Source (EtherCAT Option Board) .....	3-12
Figure 3-15. Remote Power Programming Using Current Source (Digital Option Board only).....	3-13
Figure 3-16. Remote Power Programming Using 0-10 VDC Voltage Source (Digital Option Board only).....	3-14
Figure 3-17. Remote Sensing Operation at the Load .....	3-15
Figure 3-18. Remote Output ON/OFF Control by Contact Closure (Digital Option Board) .....	3-15
Figure 3-19. Remote Output ON/OFF Control by Contact Closure (SG compatible Option Board) .....	3-16
Figure 3-20. Remote Output ON/OFF Control by Contact Closure (EtherCAT Option Board).....	3-16
Figure 3-21. Parallel and Remote/Local Sense Connections .....	3-18
Figure 3-22. Parallel and Remote Sense Connection of ASD as Master and SG as Slave .....	3-19
Figure 4-1. Block Diagram, External Process Control Feature .....	4-10

This page intentionally left blank.

# SECTION 1 OVERVIEW

## 1.1 GENERAL DESCRIPTION

The Sorensen ASD Series with DaVinci Power technology offers the highest power density available at 30kW in 3U, for precision programmable AC – DC power conversion. This water-cooled power supply allows for use in environments that typically exclude air-cooled power supplies and is designed for industry leading load transient response with outstanding output ripple and noise characteristics.

The ASD advanced digital architecture and its graphical user interface allow real-time digital control and monitoring, with a flight data recorder feature to facilitate diagnosis and maintenance activities.

Figure 1-1 decodes the ASD Series model number.

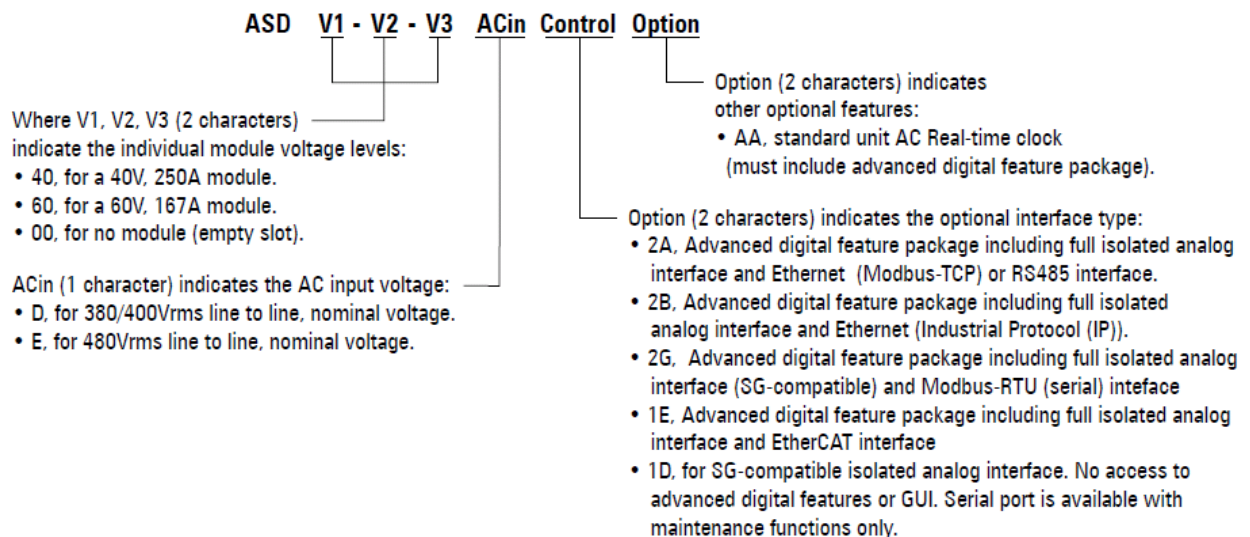

**Figure 1-1. Model Number Decoding**

## 1.2 SPECIFICATIONS

The following subsections provide environmental, electrical, and physical characteristics for the ASD Series power supplies.

**Note:** Specifications are subject to change without notice.

**Note:** The ASD Series power supplies are intended for indoor use only. Please refer to Section 2.3 for use/location requirements.

### 1.2.1 ENVIRONMENTAL CHARACTERISTICS

Parameter	Specification	
Temperature Coefficient	0.02%/°C of maximum output voltage rating for voltage set point. 0.03%/°C of maximum output current rating for current set point.	
Ambient Temperature		
Operating	0 to 50°C	
Storage	-25° to 65°C	
Cooling, by water	Flow (gpm)	1.5 nominal, 1.25 minimum, 1.75 maximum NOTE: Internal condensation must be prevented by ensuring that the coolant is sufficiently high compared with the ambient air dew point.
	Temperature	25°C nominal, 20°C minimum, 30°C maximum
	Pressure	80 PSI maximum
	Pressure drop	Typical 12 PSI @ 1.5gpm per chassis
Humidity	Relative humidity up to 95% maximum, non-condensing	
Altitude	Operating full power available up to 5,000 feet (1,524m), derate 10% of full power for every 1,000 feet higher non-operating to 40,000 feet (12,192m)	
Agency Approvals	NRTL certified to UL/CSA 61010 and IEC/EN 61010-1, CE Compliant, LVD Categories: Installation Category II: Pollution Degree 2; Class II Equipment: for Indoor Use Only. Rack mount equipment requires proper enclosure provided in end use. EMC Directive, EN 661326:1998	

## 1.2.2 ELECTRICAL CHARACTERISTICS

The voltage accuracy specifications are valid only with remote sense connected.

Parameter	Specification			
<b>Input</b>				
Voltage Ranges	342 VAC to 440 VAC (model D). Nominal rating is 380/400 VAC 432 VAC to 528 VAC (model E). Nominal rating is 480 VAC			
Frequency	Rated 47 through 63 Hz			
Efficiency	>91% (typical), nominal line, full load.			
Phases	3-phase, 3-wire plus ground. Not phase rotation sensitive. Neutral not used.			
Max Current, per phase, low line		400/380 VAC	480 VAC	
	10kW unit (1 module)	21 Arms	17 Arms	
	20kW unit (2 modules)	42 Arms	33 Arms	
	30kW unit (3 modules)	63 Arms	50 Arms	
Current Inrush	200A Typical			
Power Factor	>0.9 @ Full Load and at nominal line			
Brownout Provisions	Designed to meet SEMI F47-0706, S3, S8, S14 at nominal input voltages			
<b>Output</b>				
Voltage Output	Noise (pk-pk)* 10kW and 20kW units	Noise (RMS)** 10kW and 20kW units	Noise (pk-pk)* 30kW unit	Noise (RMS)** 30kW unit
40Vdc	300mV	80mV	150mV	40mV
60Vdc	300mV	80mV	150mV	40mV
* Measured at the output terminals, with 1uF in parallel with supply operating at full load and nominal input line voltage.				
** RMS noise is measured directly across the output terminal with supply operating at full load and nominal input line voltage.				
<b>Sense</b>	To compensate load cables voltage drop, units can generate 2% additional voltage at full scale of output voltage.			
<b>Load Regulation</b> (Specified at no load to full load change, nominal AC input)				
Voltage	0.1% of maximum output voltage / current			
Current	0.1% of maximum output voltage / current			
<b>Line Regulation</b> (Specified $\pm 10\%$ of nominal AC input, constant load)				
Voltage	0.05% of maximum output voltage / current			
Current	0.05% of maximum output voltage / current			
Transient Response	A 50% step load will recover to within 0.75% of original value within 1 ms.			
Stability	$\pm 0.05\%$ of set point over 8 hours at fixed line, load, and temperature, after 30-minute warm-up			

Parameter	Specification
<b>Analog Remote Programming</b>	
Voltage Accuracy	0.5% of full-scale
Current Accuracy	1% of full-scale
Power Accuracy	1.5% of full-scale
Voltage Monitoring	0.5% of full-scale
Current Monitoring	1% of full scale
Power Monitoring	1.5% of full-scale
Programming Range	0-10Vdc, 4-20mA
<b>Output Float</b>	Units may be put in series with the float limit of output terminals must be within $\pm 150V$ of chassis potential
<b>Parallel</b>	Multiple units can be paralleled to form higher power systems. Chassis control loops are tied together so that resulting higher power systems have the same transient response as a 30kW system. Control commands are only required to be sent to a "master" supply. Parallel supplies require a shielded CAT 5 cable (STP) and appropriate output wiring connections by the user.
<b>Calibration</b>	End user calibration is supported. All standard and digital calibration can be performed without removing covers.
<b>Digital Control (Optional)</b>	<ol style="list-style-type: none"> <li>1) Ethernet TCP/IP with Modbus-TCP protocol, or</li> <li>2) RS-485 half-duplex with Modbus-RTU protocol, or</li> <li>3) Ethernet/IP, or</li> <li>4) EtherCAT</li> </ol>
<b>Analog Control</b>	All control signals are isolated from the outputs.

### 1.2.3 PHYSICAL CHARACTERISTICS

Dimension	30kW	20kW	10kW
Width	19.00 in (48.3 cm)	19.00 in (48.3 cm)	19.00 in (48.3 cm)
Depth	30.00 in (76.2 cm)	30.00 in (76.2 cm)	30.00 in (76.2 cm)
Height	5.22 in (13.25 cm) rack mount	5.22 in (13.25 cm) rack mount	5.22 in (13.25 cm) rack mount
Weight	$\leq 125$ lbs (56.69 kg)		

# SECTION 2 INSTALLATION

## 2.1 INSPECTION

Inspect the shipping carton for possible damage before unpacking the unit. Carefully unpack the equipment. Save all packing materials until inspection is complete. Verify that all items listed on the packing slips have been received. Visually inspect all exterior surfaces for broken knobs, connectors, or meters. Inspect for dented or damaged exterior surfaces. External damage may be an indication of internal damage. If any damage is evident, immediately contact the carrier that delivered the unit and submit a damage report. Failure to do so could invalidate future claims. Direct repair issues to Customer Service at 858-458-0223 (local) or 1-800-733-5427(toll free).

## 2.2 CONTENTS OF SHIPMENT







Depending on the model, configuration, and options available for your ASD Series power supply, the ship kit may include additional parts and accessories. At a minimum, the ship kit that accompanies your ASD Series power supply includes the following items:

- ASD Series DC Power Supplies Operation and programming Manual (Part No. M551177-01)
- Sense mating connector (Molex P/N 39-01-4031) with loose contacts (Molex P/N 39-00-0182)
- J1 mating connector (Cinch P/N DB25P or equivalent) normally shipped attached to rear panel J1
- Back shell for J1 (DB25) mating connector (Amphenol P/N 17E17262 and CINCH P/N DB19678-7)
- Modular terminator (Ametek P/N 5551009-01)
- Water pipe plugs (Caplug P/N P-38B)
- Bolt, lock washer, and nut for output power connections:
- If bus bars installed in unit, four each: 3/8-16 x 1.00" brass screw, 3/8 flat brass washer, and 3/8 split lock brass washer.

- For every module output without bus bar installed, two 3/8-16 x 1.00" brass screws, four 3/8 flat brass washer, two 3/8 split lock brass washer, and two 3/8-16 brass nuts.
- Black screw, 10-32UNC-2B x 1/2", front panel rack fastener:
- 10-30 kW: 4 ea

**Note:** If any of these parts are missing, please contact Customer Service at 858-458-0223 (local) or 1-800-733-5427 (toll free).

## 2.3 LOCATION AND MOUNTING

	<b>WARNING!</b> To reduce the risk of fire or electrical shock, install the ASD Series unit in a temperature and humidity controlled indoor area, free of conductive contaminants.
	<b>CAUTION!</b> The unit should not be installed in a raised ambient temperature greater than 50°C.
	<b>CAUTION!</b> This unit is intended for installation in a protected environment. No user serviceable parts inside. Service to be performed by qualified personnel only.
	<b>CAUTION!</b> Ensure that the concentration of ozone is limited to a safe value. The recommended long-term exposure limit for ozone is 0.1 PPM (0.2 mg/m <sup>3</sup> ).
	<b>BURN HAZARD!</b> Hot Surface Warning. Allow to cool before servicing.
	<b>CAUTION!</b> A minimum three-person lift is required for the ASD Series unit, which weighs up to 125 lbs (57kg) depending on the model.

Please refer to sections 2.8 and 2.9 for dimensional and installation drawings, respectively.

### 2.3.1 RACK

The ASD Series models are designed for mounting in a standard 19-inch equipment rack. If additional instrumentation is mounted in the rack, no additional clearance is required above or below units in the ASD Series.

1. Support the unit using rack mount slides or appropriate L brackets  
Suggested rack mount slide kit: Jonathan P/N 370EZ-28
2. Secure the unit in place using the screws provided.



### 2.3.2 CHASSIS REMOVAL FROM RACK

The slides have a Front Disconnect Feature and lock at full extension.

To return the chassis back into the rack from full extension, depress the flat steel spring inward (located on the slides) and push the chassis back.

To disconnect and remove the chassis from the rack, depress the flat steel spring inward (located on the slides) and pull the chassis forward.

When the chassis is at full extension, the flat springs are located approximately one (1) inch behind the front EIA RETMA rails. Access the springs with a flat blade screwdriver or similar device to release from lock-out or to remove the chassis from the rack.

The slides can be mounted to the chassis with this spring oriented on the top or the bottom of the slide.

## 2.4 COOLANT CONNECTIONS



### WARNING!

Avoid risk of electrical shock. Ensure no electrical connections are made until connections to the fluid fittings are secure and dry. Ensure that no moisture comes into contact with electrical components or connections.

Do not remove cover. Refer to qualified service personnel.

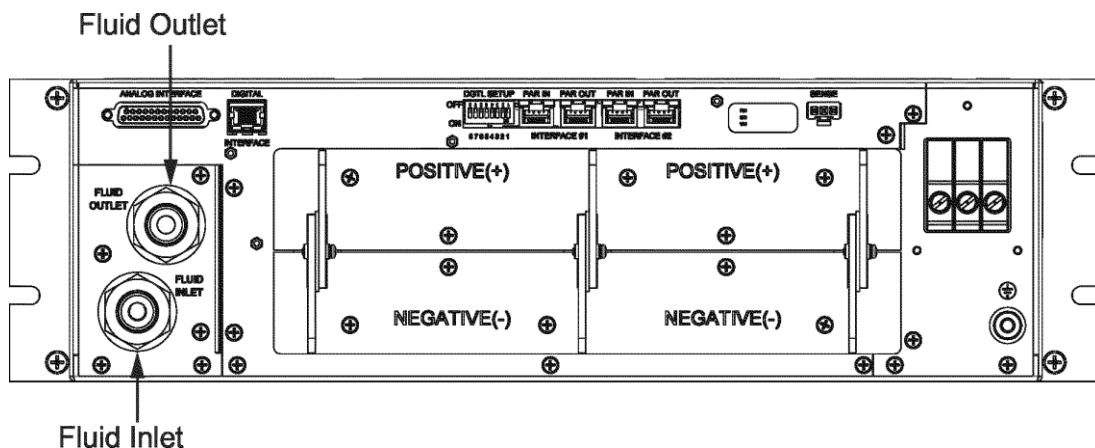

Figure 2-1. Rear Panel Coolant Connectors

### 2.4.1 WATER QUALITY

DO NOT use de-ionized water or distilled water.

The quality of the supplied facility cooling water must have the following specifications:

- **Particulate:** Supply filtered to 10 microns.
- **Hardness:** 60 ppm maximum (calcium & magnesium carbonates)

- **Silica:** 60 ppm maximum
- **TDS( Total Dissolved Solids):** 800 ppm maximum
- **pH value:** maintain slightly alkaline solution 7-8 pH
- **Conductivity:** Less than 2000 micro-ohms/cm
- **Biocides:** Use non-chloride based biocidal additives (bactericide, algaecide) to kill microorganisms and prevent their growth.
- **Corrosion:** Use corrosion inhibitors to minimize the negative effects of corrosion. ( Nitrite borate or Sodium nitride).

## 2.5 INPUT/OUTPUT ELECTRICAL CONNECTIONS



**WARNING!**

High voltage present! Risk of electrical shock.

Ensure all areas are dry and that there is no leakage around the fluid inlet or outlet.

Do not remove cover. Refer to qualified service personnel.

For permanently connected equipment, incorporate a readily accessible disconnect device in the fixed wiring. For pluggable equipment, install the socket outlet near the equipment and in an easily accessible location.



**CAUTION!**

Proper connection to the mains requires a circuit breaker or fuse with a rating of 25% over the maximum input line currents listed in Section 1.2.2.



**WARNING!**

Under no condition should the negative output terminal exceed 150V to earth ground.

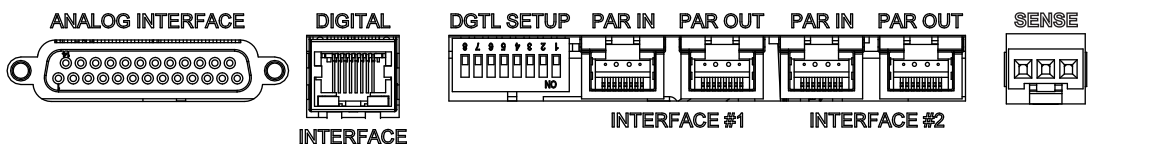

Figure 2-2. Rear Panel Connections: Analog Interface

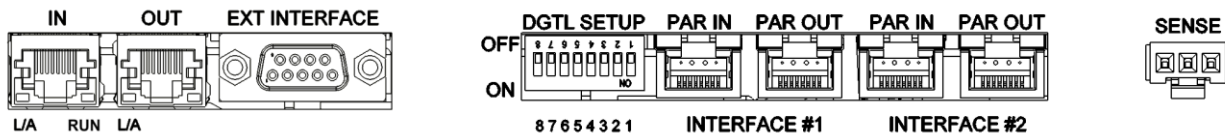

Figure 2-3. Rear Panel Connections: EtherCAT Interface

## 2.5.1 ISOLATED ANALOG INTERFACE CONNECTIONS

Table 2-1 and Table 2-2 describe the available input and output signals at the DB25 connectors for standard ASD units and the SG compatible interface. Table 2-3 describes the available input and output signals at the DB9 connector for ASD units with the EtherCAT interface option. Section 2.9 provides a drawing of the rear panel input/output connector locations.

**Table 2-1. Analog Interface Signals. Standard ASD Pin-out (DB25)**

PIN #	PIN NAME	IN/OUT	DESCRIPTION
1	I_MON	A/OUT	a 0-10 VDC monitor signal (or 4-20 mA DC) that indicates zero to full scale output current
2	V_MON	A/OUT	a 0-10 VDC monitor signal (or 4-20 mA DC) that indicates zero to full scale output voltage
3	P_MON	A/OUT	a 0-10 VDC monitor signal (or 4-20 mA DC) that indicates zero to full scale output power
4	V_MODE	D/OUT (*)	LO indicates the unit is not in voltage mode, HI indicates the unit is in voltage mode if I_MODE is low. If both I_MODE and V_MODE are HI, it means power mode.
5	I_MODE	D/OUT (*)	LO indicates the unit is not in current mode, HI indicates the unit is in current mode if V_MODE is low. If both I_MODE and V_MODE are HI, it means power mode.
6	STATUS	D/OUT (*)	LO indicates output disabled, HI indicates the output is enabled.
7	FAULT	D/OUT (*)	LO indicates normal operation, HI indicates a fault.
8	DOUT_REF	IN	Used to define the output high level of the digital outputs. If not connected, the output high is 12V. If connected to 24Vdc, the output high is 24V.
9	GND	common	Same as pin 16
10	+24Vdc	OUT	+24VDC, same as pin 17
11	I_PROG	A/IN	a 0-10 VDC analog input signal (or 4-20 mA DC) that programs zero to full scale output current
12	V_PROG	A/IN	a 0-10 VDC analog input signal (or 4-20 mA DC) that programs zero to full scale output voltage
13	P_PROG	A/IN	a 0-10 VDC analog input signal (or 4-20 mA DC) that programs zero to full scale output power
14	START/STOP	D/IN (**)	LO disables output, HI enables output.
15	RESET	D/IN (**)	LO to HI transition clears faults and warnings.
16	GND	common	Same as pin 9
17	+24Vdc	OUT	+24VDC, same as pin 10
18	GND	common	Same as pin 9
19	GND	common	Same as pin 9
20	Not used		
21	Not used		
22	RS-485 enable	D/IN	A high level will disable the Ethernet Interface to be able to use Modbus over RS-485
23	RS-485 A	D/IO	Modbus interface over RS-485
24	RS-485 B	D/IO	Modbus interface over RS-485
25	RS-485 GND	common	Ground for serial interface (it is not isolated from the common ground)

Digital signal levels:

(\*) Digital output low is 0V (<0.5V), output high is either 12V or 24V (+/-1V), depending on pin 8.

(\*\*) Digital input low is 0.5V or lower, input high is 8V or higher.

**Table 2-2. Analog Interface Signals. SG-compatible Pin-out (DB25)**

PIN #	PIN NAME	IN/OUT	DESCRIPTION
1	Not used.		
2	Not used.		
3	Not used.		
4	GND	common	
5	ON/OFF	D/IN	LO = 0 VDC enables output, HI > 8 VDC disables output.
6	GND	common	
7	I_MON	A/OUT	a 0-10 VDC monitor signal (or 4-20 mADC) that indicates zero to full scale output current. (Zout ~ 10 ohms for voltage signal)
8	Not used.		
9	Not used.		
10	Not used.		
11	Not used.		
12	Not used.		
13	Not used.		
14	Not used.		
15	V_PROG	A/IN	a 0-10 VDC analog input signal (or 4-20 mADC) that programs zero to full scale output voltage. (Zin ~ 200 Kohms for voltage signal)
16	I_PROG	A/IN	a 0-10 VDC analog input signal (or 4-20 mADC) that programs zero to full scale output current. (Zin ~ 200 Kohms for voltage signal)
17	FAULT	D/OUT	LO = 0 VDC indicates normal operation, HI = 12 VDC indicates a fault. See Table 4-11 for a list of faults and their description.
18	Not used.		
19	V_MON	A/OUT	a 0-10 VDC monitor signal (or 4-20 mADC) that indicates zero to full scale output voltage. (Zout ~ 10 ohms for voltage signal)
20	GND	common	
21	Not used.		
22	Not used.		
23	GND	common	
24	GND	common	
25	GND	common	

**Table 2-3. Pin-out of the Reduced Analog Interface Connector (DB9)**

PIN #	PIN NAME	IN/OUT	DESCRIPTION
1	RS-485 A	D/IO	Modbus-RTU interface
2	START/STOP	D/IN (**)	LO disables output, HI enables output.
3	+24Vdc	OUT	+24VDC output, 100mA max
4	I_PROG	A/IN	a 0-10 VDC analog input signal (or 4-20 mADC) that programs zero to full scale output current
5	GND	-	ground
6	RS-485 B	D/IO	Modbus-RTU interface
7	STATUS	D/OUT	LO indicates output disabled, HI indicates the output is enabled.
8	V_MODE	D/OUT	LO indicates the unit is not in voltage mode, HI indicates the unit is in voltage mode.
9	V_PROG	A/IN	a 0-10 VDC analog input signal (or 4-20 mADC) that programs zero to full scale output voltage

## 2.5.2 EXTERNAL SWITCHES

The eight position DIP switch labeled DGTL SETUP is used for power supply configuration. The following table lists each position and its function:

Switch number	Description
1	DOWN (on) = 0 – 10 VDC monitor signals and analog programming references  UP (off) = 4 – 20 mADC monitor signals and analog programming references. If the input current is lower than 2 mA, the unit will generate a fault.
2	DOWN (on) = remote voltage sense disabled.  UP (off) = remote voltage sense enabled.
3	DOWN (on) = master enabled (sets the master as active).  UP (off) = master disabled (the modules in the chassis will operate with an external master).
4 to 7	Unit address or expected number of modules, depending on switch 8. Use these switches to define a binary number from 0 to 15 (1111 in binary), switch 4 is the least significant bit and switch 7 the most significant.  DOWN (on) is a binary ZERO  UP (off) is a binary ONE  The unit address or expected number of modules will be the binary value plus one (giving a range of 1 to 16).
8	DOWN (on) = switches 4-7 are used to set the unit address, necessary for the digital interface.  UP (off) = switches 4-7 are used to indicate the power supply how many modules it should expect to discover. For more details please see the description of the expected number of modules feature.

**Table 2-4. Input/Output Connectors**

Connector	Function	Connects To
FL1 – AC FL1 – AC FL1 – AC Chassis - GND	Prime AC Power Input See Table 2-5. Not phase rotation sensitive. Neutral not used.	380/400 VAC (Option) 440/480 VAC (Option) 47-63 Hz, 400 Hz
Pos. Bus Bar Neg. Bus Bar	Output Power: (see Table 2-6)	User load(s)
ANALOG CONTROL Connector (J1)	Control Interface	See 3.3.5 for description
Sense Connector	Used for remote sense	Refer to Section 3.7
Parallel In-Out	Used for parallel operation	Refer to Section 3.9

**Table 2-5. Input Connections**

Connection	Description
Input AC connector	Feed through high current terminal block

**Table 2-6. Output Connections**

Connection	Description
Bus Bar	Bus Bar with two holes for each potential terminal 3/8".
Module terminals	Output terminals with holes for 3/8" bolts (40V-60V)

**CAUTION!**

Prevent damage to the unit: follow torque specifications, use correct size wire ferrule (if used), and proper size ferrule crimping tool.

**TORQUE SPECIFICATIONS**

- The unit's Phoenix Connectors require 18 in-lb to 20 in-lb (2 Nm to 2.3 Nm) torque.
- Wire ferrules are recommended; their size must match the wire gauge.
- Crimp tool size must be appropriate to the ferrule size.
- Wire insulation should be stripped back no more than 5/8 inch for the ferrule.

For more information on this AC input connector, please look up Phoenix Contact part number HDFKV 16 at [www.phoenixcontact.com](http://www.phoenixcontact.com).

## 2.6 WIRE SELECTION

Care must be taken to properly size all conductors for the input and output of the power supply. This section provides guidance in the selection of wire size. Note that cables with Class B or C stranding should be used. Fine stranded cables should not be used unless crimp-on lugs or ferrules are used that are approved for fine stranded cables.

### 2.6.1 WIRE SIZE

The tables below will assist in determining the appropriate wire size for both the input and output connections Table 2-7 below gives *minimum* recommended wire size. This table is derived from the National Electrical Code; it is for reference only. Local laws and conditions may have different requirements. Note that these recommendations are for copper wire only. For higher ratings, wires can be paralleled; refer to the National Electrical Code.

**Table 2-7. Minimum Wire Size**

Size	Temperature Rating of Copper Conductor			
	60°C	75°C	85°C	90°C
AWG MCM	Types: RUW, T, TW, UF	Types: FEPW, RHW, RH, RUH, THW, THWN, XHHW, USE, ZW	Types: V, MI	Types: TA, TBS, SA, AVB, SIS, FEP, FEPB, RHH, THHN, XHHW
	<b>Current Rating</b>			
14	20	20	25	25
12	25	25	30	30
10	30	35	40	40
8	40	50	55	55
6	55	65	70	75
4	70	85	95	95
3	85	100	110	110
2	95	115	125	130
1	110	130	145	150
0	125	150	165	170
00	145	175	190	195
000	165	200	215	225
0000	195	230	250	260

When determining the optimum cable specification for your power applications, the same engineering rules apply whether going into or out of an electrical device. Thus, this guide applies equally to the input cable and output cable for this Sorensen instrument and application loads.

Power cables must be able to safely carry maximum load current without overheating or causing insulation destruction. It is important to everyday performance to minimize IR (voltage drop) loss within the cable. These losses have a direct effect on the quality of power delivered to and from instruments and corresponding loads.

When specifying wire gauge, consider the operating temperature. Wire gauge current capability and insulation performance drops with the increased temperature developed within a cable bundle and with increased environmental temperature. Thus, short cables with generously derated gauge and insulation properties are recommended for power source applications.

Be careful when using published commercial utility wiring codes. These codes are designed for the internal wiring of homes and buildings and accommodate the safety factors of wiring loss, heat, breakdown insulation, aging, etc. However, these codes consider that up to 5% voltage drop is acceptable.

Such a loss directly detracts from the quality performance specifications of this Sorensen instrument. Also, consider how the wiring codes apply to bundles of wire within a cable arrangement.

In high performance applications requiring high inrush/ transient currents, additional consideration is required. The cable wire gauge must consider peak voltages and currents, which may be up to ten times the average values. An underrated wire gauge adds losses, which alter the inrush characteristics of the application and thus the expected performance.

Table 2-8 presents wire resistance and resulting cable voltage drop at maximum rated current.

**Table 2-8. Wire Resistance and Voltage Drop**

<b>Column 1</b>	<b>Column 2</b>	<b>Column 3</b>	<b>Column 4</b>
<b>Size</b>	<b>Amperes</b>	<b>Ohms/100 Feet</b>	<b>Voltage Drop/100 Feet</b>
14	20	0.257	5.14
12	25	0.162	4.05
10	30	0.102	3.06
8	40	0.064	2.56
6	55	0.043	2.36
4	70	0.025	1.75
2	95	0.015	1.42
1/0	125	0.010	1.25
3/0	165	0.006	1.04

Refer to Section 1.2.2 for AC input and output current requirements.



Refer to Table 2-9 for input/output lug recommendations.

**Table 2-9. Recommended Lugs**

Lug Manufacturer	Input/Output
Panduit	"PN" Series or equivalent "LCAN" Series for higher current
<b>Note:</b> Contact lug manufacturer for recommended crimping tool.	

The recommended tools for crimping and extraction of the sense connector pins are listed below in Table 2-10.

**Table 2-10. Recommended Sense Connector Tools**

Tool	Manufacturer	Manufacturer P/N
Crimping	Molex	11-01-0197
Extracting	Molex	11-03-0044

## 2.7 LOAD CONSIDERATIONS

This section provides guidelines for using properly rated diodes to protect the power supply from damage while driving inductive loads.

### 2.7.1 INDUCTIVE LOADS

To prevent damage to the power supply from inductive kickback, connect a diode (rated at greater than the supply's output voltage and current) across the output. Connect the cathode to the positive output and the anode to return. Where positive load transients such as back EMF from a motor may occur, a second diode in series with the output is recommended to protect the power supply.

#### BLOCKING AND FREE WHEELING DIODES

The Peak Reverse Voltage ratings should be a minimum of 2-3 times the Power Supply maximum output voltage. The Continuous Forward Current ratings should be a minimum of 1.5 times the Power Supply maximum output current. Heatsink may be required. There also may be a need for higher voltage rated parts, dependent on load circuit design and inductor values.

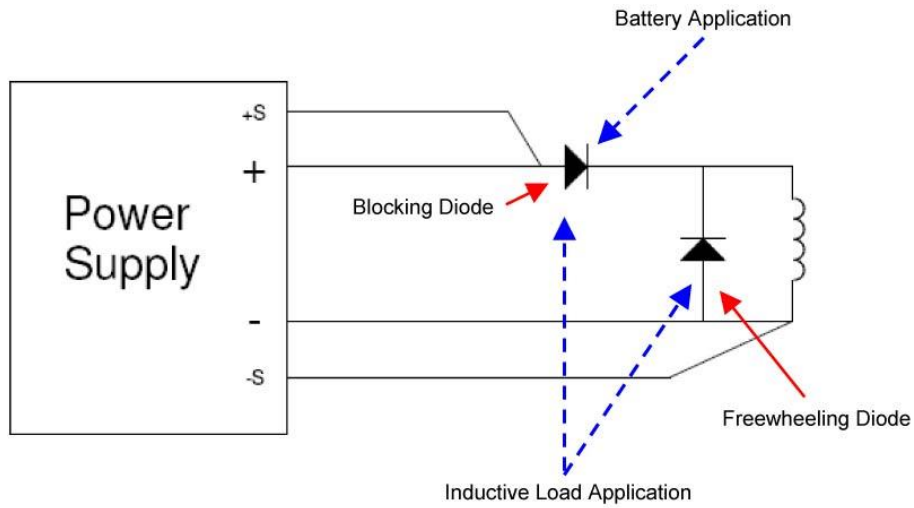

Figure 2-4. Diode Connection

## 2.8 OUTLINE DRAWINGS

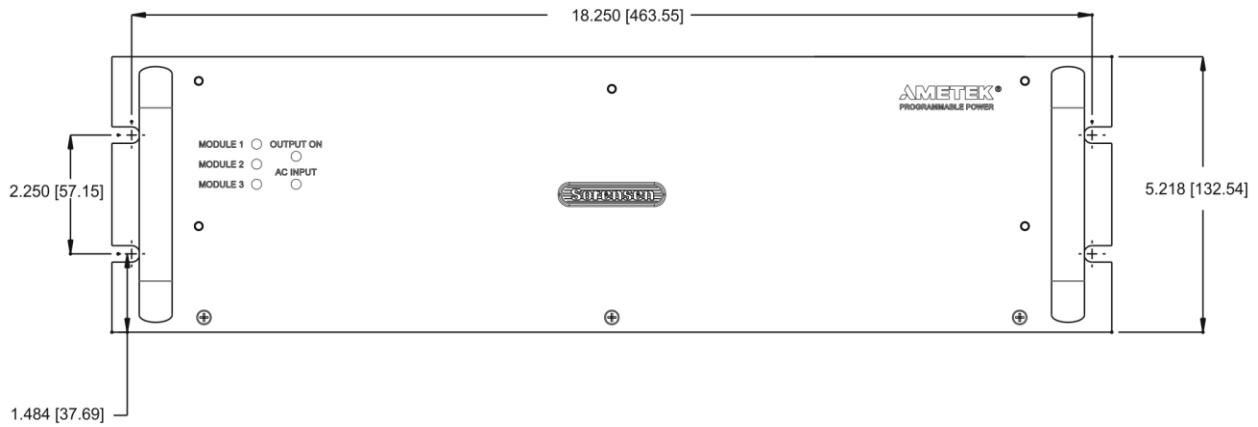

Figure 2-5. ASD Dimensions, Front View

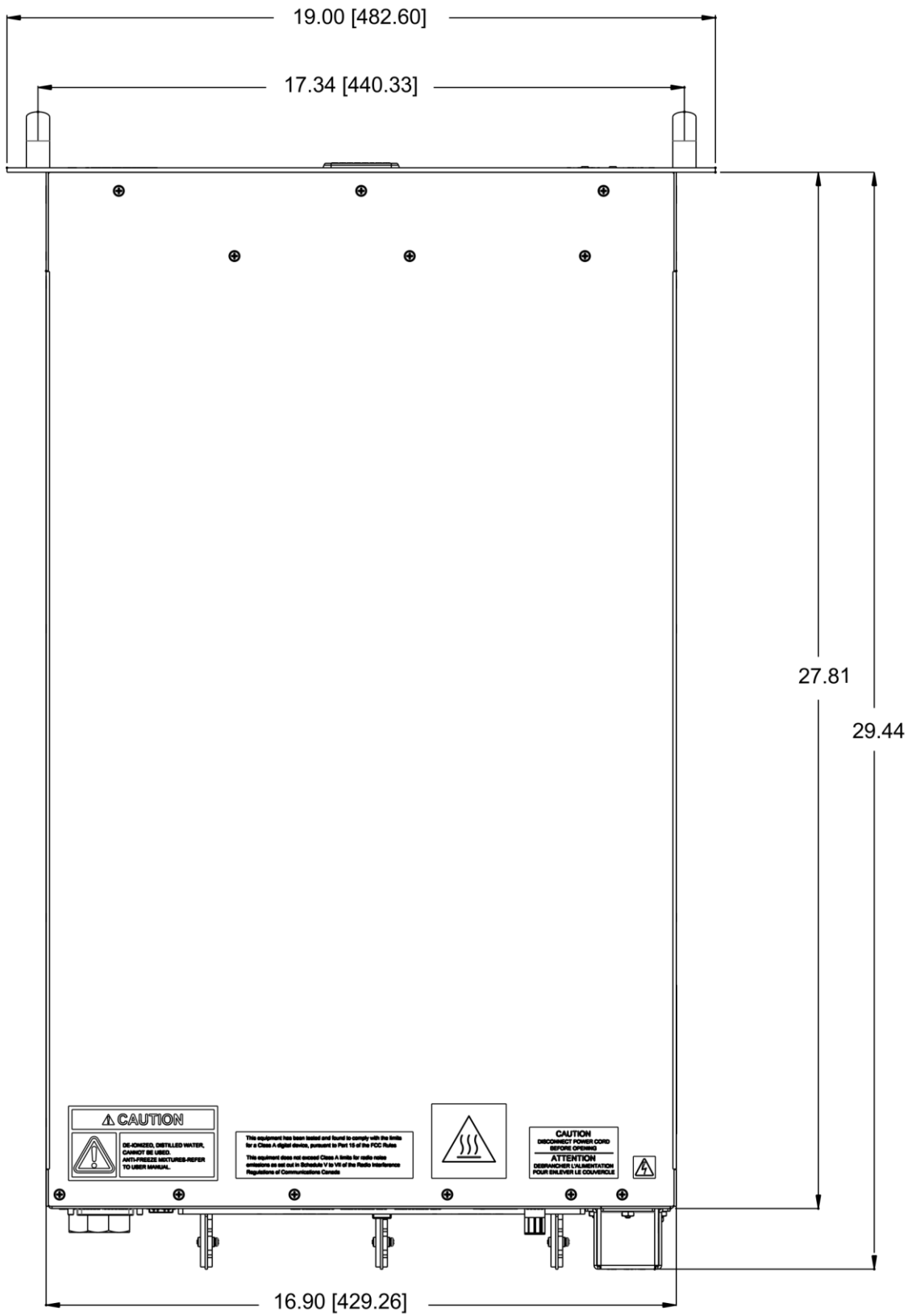

Figure 2-6. ASD Dimensions, Top View

## 2.9 INSTALLATION DRAWINGS

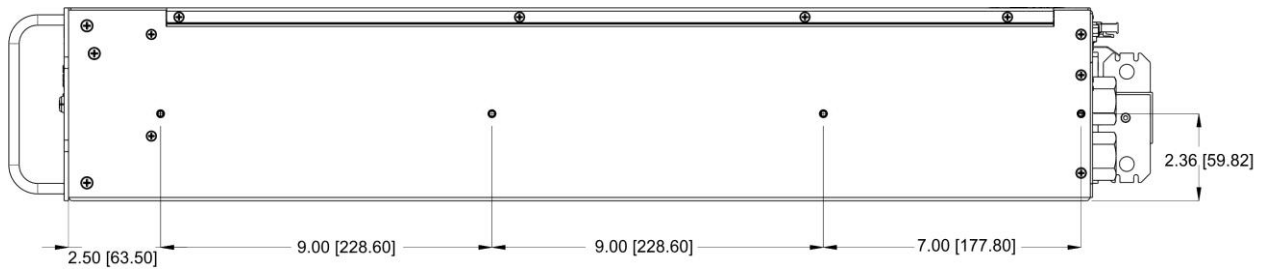

Figure 2-7. Slide Rack Mounting Holes

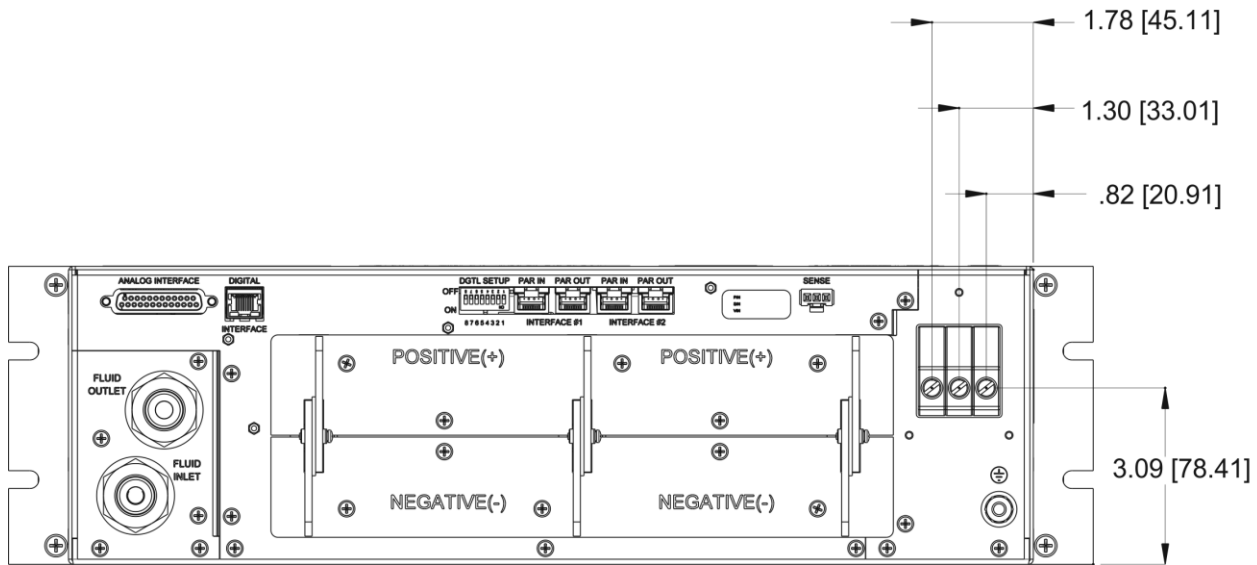
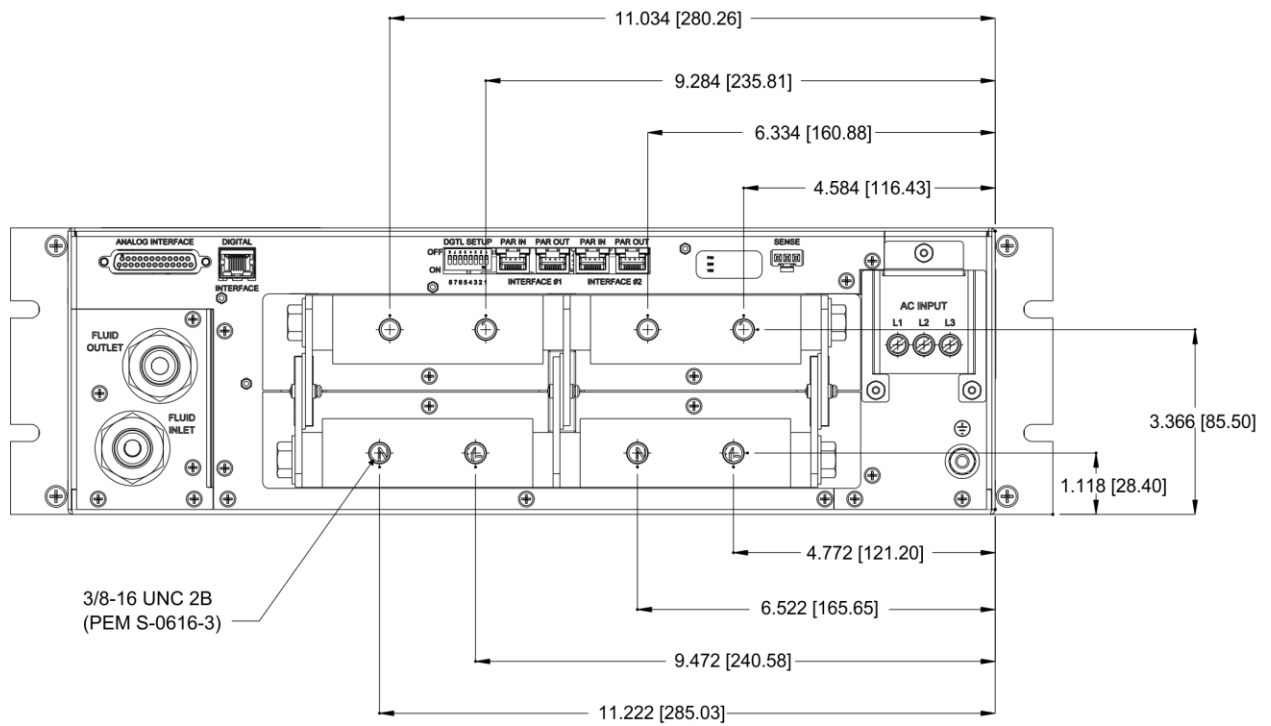

Figure 2-8. Rear Panel AC Connectors



**Figure 2-9. Rear Panel Bus Bar Connectors**

This page intentionally left blank.

## SECTION 3 OPERATION

### 3.1 INTRODUCTION

This section begins with a description of the ASD power supply front and rear panels and then presents the user interface for operating the power supply.



**WARNING!**

The power-up factory default state is output enabled.

### 3.2 FRONT PANEL

The ASD front panel has LEDs to indicate the status of the power supply and of the modules.

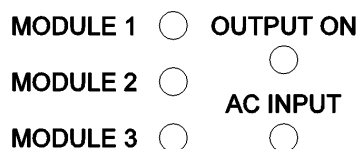

*Figure 3-1. Status LEDs*

The MODULE LEDs represent the modules inside the unit by location: from the view of the front panel, MODULE 1 is located at the left side of the unit; MODULE 2 is in the center; MODULE 3 is located at the right.

The LED labeled “AC INPUT” indicates that the unit is powered and also shows the unit and master controller condition based on the color code.

The LED color codes for the MODULE and AC INPUT are as follows:

- Green = normal condition of the module or unit.
- Yellow = abnormal condition (warning or not severe fault).
- Red = severe fault that shuts down the module or unit.

The LED labeled “OUTPUT ON” is green when the power supply has set the output to active mode. If it is off it means that the internal power stages are not active.

### 3.3 DIGITAL OPERATION

The ASD Series power supply is shipped from the factory configured for local voltage/current control and local voltage sensing. The ANALOG CONTROL connector is supplied with a mating connector with remote output ON/OFF jumper for ON (terminal 5 shorted to terminal 6 on unit with SG compatible option board, terminal 14 shorted to terminal 17 on unit with digital option board, or terminal 2 shorted to terminal 3 on unit with EtherCAT option board).

**WARNING!**

The power-up factory default state is output enabled.

#### 3.3.1 FLOATING AND POLARIZED OUTPUT

The ASD Series supply can be set up for a Positive or Negative supply, as well as standard operation as a floating output supply.

##### FLOATING OUTPUT

The output terminals are normally floating from chassis ground. No extra steps or connections are required for a floating output.

##### POSITIVE SUPPLY SETUP

Attach the negative output terminal to the supply chassis. The output reference is now chassis ground. When the output voltage is set or programmed, the supply will output a positive potential from chassis ground.

##### NEGATIVE SUPPLY SETUP

Attach the Positive output terminal to the supply chassis. The output reference is now chassis ground. When the output voltage is set or programmed, the supply will output a negative potential from chassis ground.

#### 3.3.2 INITIAL SETUP

1. Check the ANALOG CONTROL (J1) mating connector on the rear panel to verify that the appropriate pins are shorted together to enable the output of the supply (see Section 3.8). This is the default configuration installed from the factory. (Terminal 5 shorted to terminal 6 on unit with SG compatible option board, terminal 14 shorted to terminal 17 on unit with digital option board, or terminal 2 shorted to terminal 3 on unit with EtherCAT Option Board).
2. Apply power to the AC mains input.



### 3.3.3 VOLTAGE MODE OPERATION

When the supply is in the Voltage mode, the output voltage of the supply is controlled by the digital Voltage setpoint on the MODBUS control interface GUI or by the remote voltage input. See Section 3.5. The digital Current setpoint (or remote current input) operates as a current limit. The output voltage is regulated at the selected value while the output current varies with the load requirements. To verify operation in Voltage mode, follow the steps below:

1. Connect a digital voltmeter (DVM) across the rear panel positive and negative output terminals, observing the correct polarity. Make sure the DVM is in the dc voltage mode and the range is adequate to handle the full-scale voltage of the power supply.
2. Apply input voltage to power supply
3. Once the MODBUS control interface is connected to power supply (See 4.6.1), Set the Current and power setpoint sliders above 0 Amps and 0 watts. Slowly increase the Voltage setpoint slider and observe both the unit readback on Master controls tab and the output of the DVM. The minimum range should be from 0V to the maximum rated voltage output of the supply. The unit readback and DVM readings should track within the accuracies of the meter and the readback.
4. Check that in unit readings, Vmode box is black meaning that unit is in voltage mode. Turn the Voltage setpoint and Current setpoint fully to zero.
5. Turn power supply input voltage off.

If Voltage mode operation did not function as indicated above, recheck your setup and perform the check again. If the function continues to fail, contact the factory for assistance.

### 3.3.4 CURRENT MODE OPERATION

When the supply is in the Current Mode, the output current of the supply is controlled by the Current setpoint slider on the master controls tab on GUI or by the remote current input (see Section 3.4). The Voltage setpoint slider (or remote voltage input) operates as a voltage limit. To verify operation in current mode, follow the steps below:

1. Connect a high current DC ammeter across the rear panel positive and negative output terminals, observing the correct polarity.
2. Select wire leads of sufficient current carrying capacity and an ammeter range compatible with the unit's maximum rated output current.

**Note:** If a high current ammeter is not available, you may simply short the output terminals together. This will not harm the supply.

3. Turn the input voltage to the power supply on.
4. Once the MODBUS control interface is connected to power supply (See Section 4.6.1), set the Voltage and power setpoint sliders above zero volts and zero watts (this sets the Voltage limit at a nominal setting above 0 Volts and forces the supply into current mode).
5. Slowly increase the Current slider and observe both the unit readback and the output of the ammeter.

The minimum range should be from 0A to the maximum rated current output of the supply.

The GUI unit readback and ammeter readings should track within the accuracies of the meter and the GUI unit readbacks

6. Check that in Master controls tab and unit readbacks, the lmode box is black.
7. Decrease the Voltage slider and Current slider fully to zero.
8. Turn the input voltage to the power supply off.
9. Disconnect the ammeter or short from the output terminals.

If Current Mode operation did not function as indicated above, recheck your setup and perform the check again. If the function continues to fail, contact the factory for assistance.

### 3.3.5 ANALOG CONTROL CONNECTOR (J1)

The ANALOG CONTROL connector on the rear panel allows the unit to be configured for different operating configurations: digital and analog current programming, digital and analog voltage programming, current and voltage output monitoring, output enable/disable, etc. The setup and operating requirements of each configuration are provided in Sections 3.4 through 3.9.

#### ISOLATED ANALOG CONTROL

The Isolated Analog Control uses the Analog Control connector (J1). This option fully isolates remote control signals and allows control of units not connected to a common ground. Control ground is isolated from power ground, which protects against potential damage from systems with high electrical noise or large ground loop currents. The isolated analog control is standard on digital option board, SG compatible board, and EtherCAT option.



#### CAUTION!

This option is not intended to allow operation of the power supply at excessive voltages. Refer to Section 2 INSTALLATION for maximum terminal voltages.

Figure 3-2 shows the J1 connector's pin-out diagram. Refer to Table 2-1, Table 2-2 and Table 2-3 for the ANALOG CONTROL connector designations and functions:

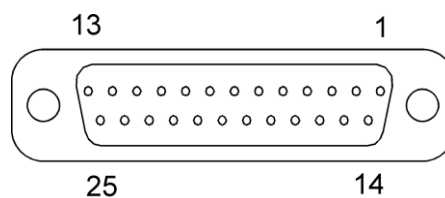

**Figure 3-2. ANALOG CONTROL Connector (J1) Pin-out**

### 3.4 REMOTE CURRENT PROGRAMMING

Remote current programming is used for applications that require the output current be programmed (controlled) from a remote source. An external voltage source may be used as a programming device.

When using remote current programming, a shielded, twisted-pair, hookup wire is recommended to prevent noise interference with programming signals.

#### 3.4.1 REMOTE CURRENT PROGRAMMING USING A 4-20mA CURRENT SOURCE

The current source coefficient for remote current programming is 16mA/100% rated output with respect to AGND (terminal 9 on digital option board, terminal 20 on SG compatible option board, or terminal 5 on EtherCAT Option Board). The programming current from I\_PROG (terminal 11 on digital option board, terminal 16 on SG compatible option board, or terminal 4 on EtherCAT Option Board) it should be from 4mA to 20mA. This yields a coefficient of 1.0% of rated output current for each 0.16mA. See Figure 3-3 through Figure 3-5 for connection requirements.

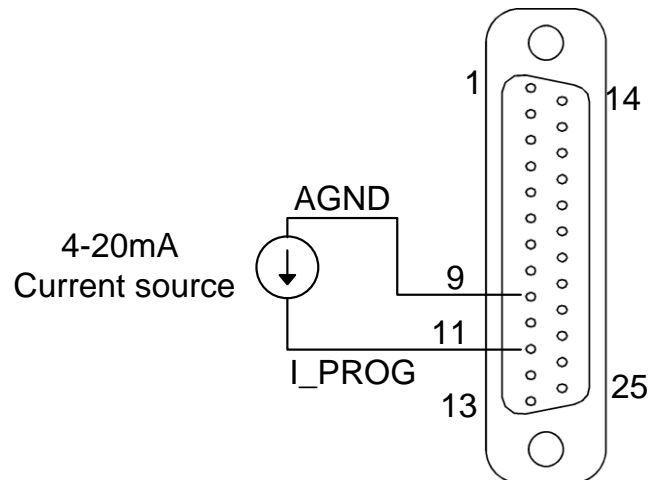

**Figure 3-3. Remote Current Programming Using Current Source (Digital Option Board)**

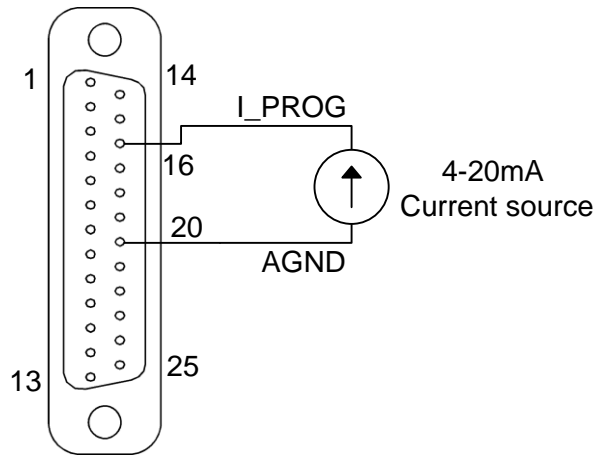

**Figure 3-4. Remote Current Programming Using Current Source (SG compatible Option Board)**

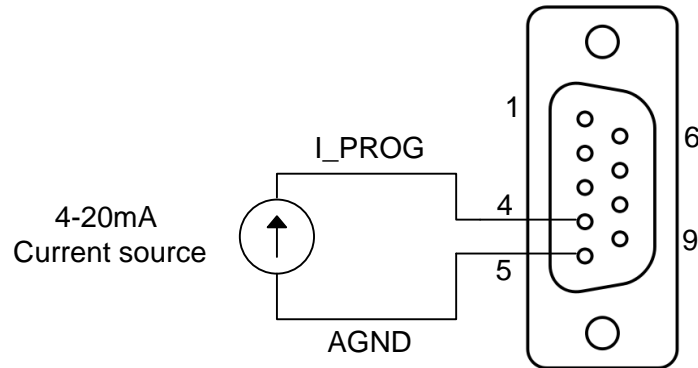
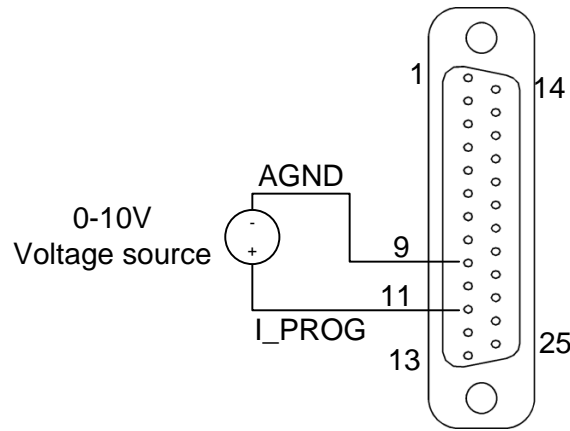

**Figure 3-5. Remote Current Programming Using Current Source (EtherCAT Option Board)**

### 3.4.2 REMOTE CURRENT PROGRAMMING USING A 0-10 VDC VOLTAGE SOURCE

A DC voltage source for remote current programming is connected between I\_PROG (terminal 11 on digital option board, terminal 16 on SG compatible option board, or terminal 4 on EtherCAT Option Board) and the return terminal AGND (terminal 9 on digital option board, terminal 20 on SG compatible option board, or terminal 5 on EtherCAT Option Board).

The voltage coefficient for 10V remote current programming is 100 millivolts = 1% of rated output, i.e., for a 500 amp model, each 100 millivolts of programming voltage equals 5 amps of output current. See Figure 3-6 to Figure 3-8 for connection requirements.



**Figure 3-6. Remote Current Programming Using 0-10 VDC Voltage Source (Digital Option Board)**

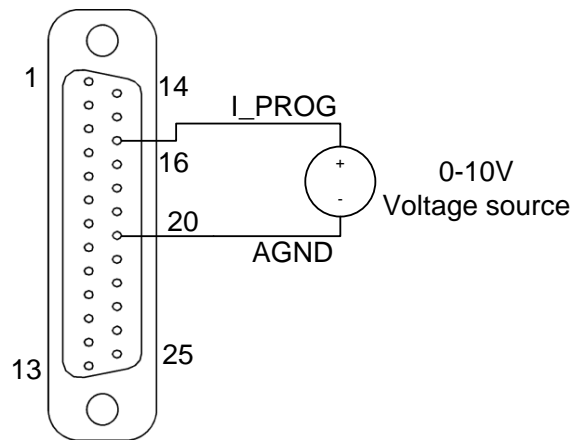

**Figure 3-7. Remote Current Programming Using 0-10 VDC Voltage Source (SG compatible Option Board)**

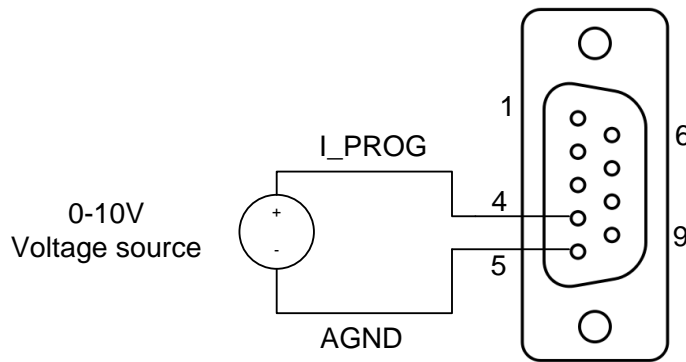

**Figure 3-8. Remote Current Programming Using 0-10 VDC Voltage Source (EtherCAT Option Board)**

## 3.5 REMOTE VOLTAGE PROGRAMMING

Remote voltage programming configuration is used for applications that require the output voltage be programmed (controlled) from a remote source. An external 4-20mA current source or external voltage source may be used as a programming device. When using remote voltage programming, a shielded, twisted-pair, hookup wire is recommended to prevent noise interference with programming signals.

### 3.5.1 EXTERNAL VOLTAGE PROGRAMMING USING A 4-20mA CURRENT SOURCE

The current source coefficient for remote voltage programming is 16mA/100% of rated output voltage with respect AGND (terminal 9 on digital option board, terminal 20 on SG compatible option board, or terminal 5 on EtherCAT Option Board). The programming current from terminal V\_PROG (terminal 12 on digital option board, terminal 15 on SG compatible option board, or terminal 9 on EtherCAT Option Board) should be a 4-20mA current source. This yields a coefficient of 1.0% of rated output voltage for each 0.16mA.

See Figure 3-9 to Figure 3-11 for connection requirements.

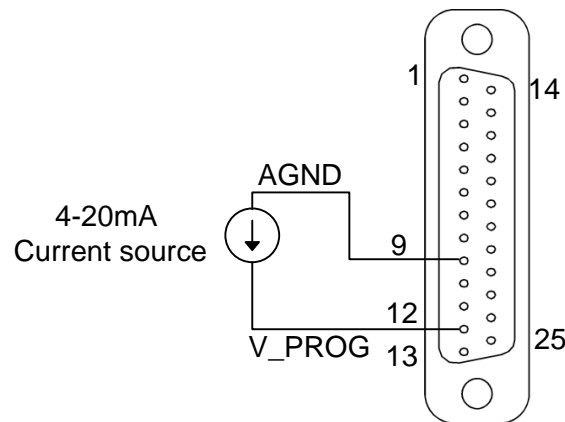

**Figure 3-9. Remote Voltage Programming Using Current Source (Digital Option Board)**

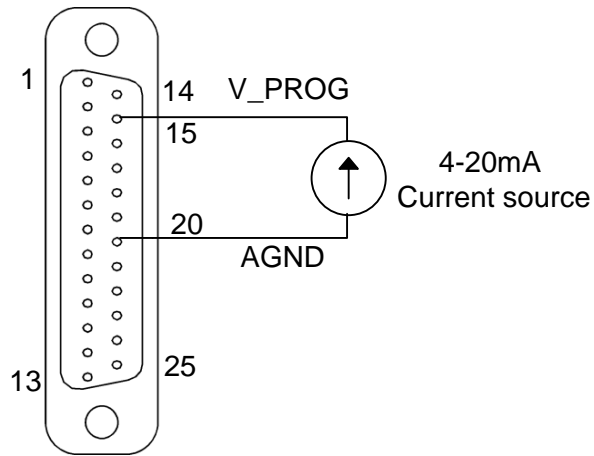

**Figure 3-10. Remote Voltage Programming Using Current Source (SG compatible Option Board)**

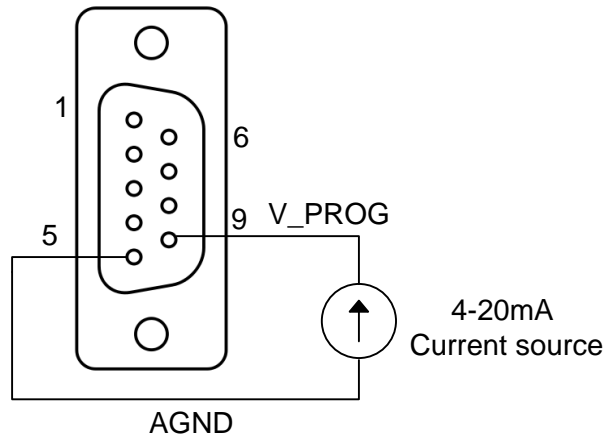

**Figure 3-11. Remote Voltage Programming Using Current Source (EtherCAT Option Board)**



### 3.5.2 EXTERNAL VOLTAGE PROGRAMMING USING A 0-10 VDC VOLTAGE SOURCE

A DC voltage source for remote voltage programming is connected between V\_PROG (terminal 12 on digital option board, terminal 15 on SG compatible option board, or terminal 9 on EtherCAT Option Board) and the return terminal AGND (terminal 9 on digital option board, terminal 20 on SG compatible option board, or terminal 5 on EtherCAT Option Board).

The voltage coefficient for 10V remote voltage programming is 10 volts = 100% of rated output voltage. See Figure 3-12 to Figure 3-14 for connection requirements.

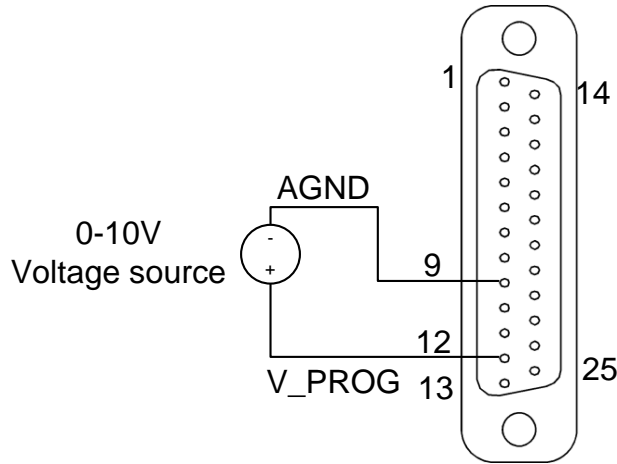

**Figure 3-12. Remote Voltage Programming Using 0-10 VDC Voltage Source (Digital Option Board)**

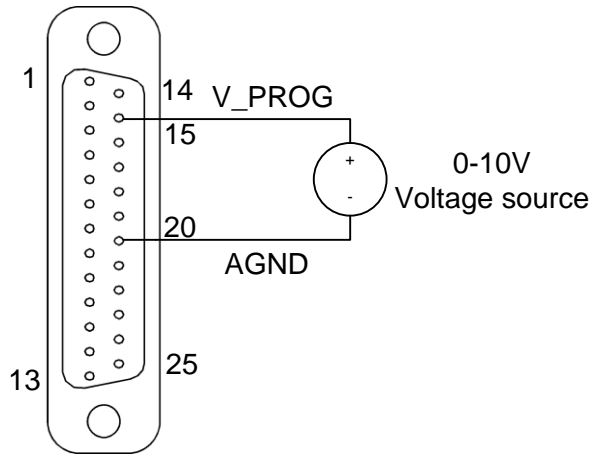

**Figure 3-13. Remote Voltage Programming Using 0-10 VDC Voltage Source (SG compatible Option Board)**

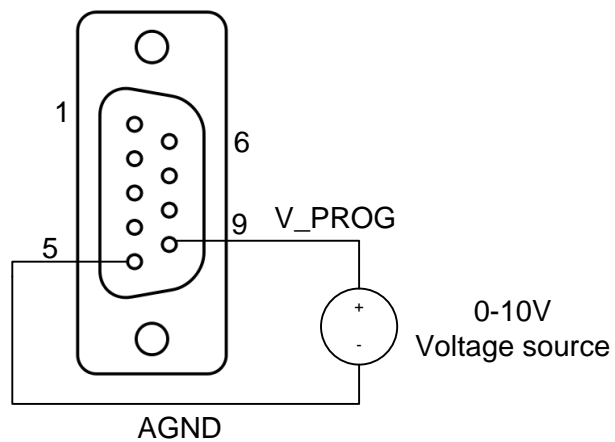

**Figure 3-14. Remote Voltage Programming Using 0-10 VDC Voltage Source (EtherCAT Option Board)**

## 3.6 REMOTE POWER PROGRAMMING

Remote power programming configuration is used for applications that require the output power be programmed (controlled) from a remote source. An external 4-20mA current source or external voltage source may be used as a programming device. When using remote power programming, a shielded, twisted-pair, hookup wire is recommended to prevent noise interference with programming signals.

### 3.6.1 EXTERNAL POWER PROGRAMMING USING A 4-20MA CURRENT SOURCE

The current source coefficient for remote power programming is 16mA/100% of rated output power with respect to GND, J1-9. The programming current from terminal J1-13 (P\_PROG) should be a 4-20mA current source. This yields a coefficient of 1.0% of rated output power for each 0.16mA. See Figure 3-15 for connection requirements.

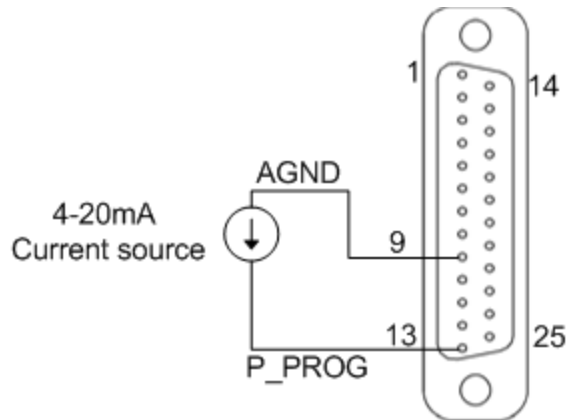

**Figure 3-15. Remote Power Programming Using Current Source (Digital Option Board only)**

### 3.6.2 EXTERNAL POWER PROGRAMMING USING A 0-10 VDC VOLTAGE SOURCE

A DC voltage source for remote power programming is connected between J1-13 (P\_PROG) and return terminal J1-9 (GND). The voltage coefficient for 10V remote power programming is 10 volts = 100% of rated output power. See Figure 3-16 for connection requirements.

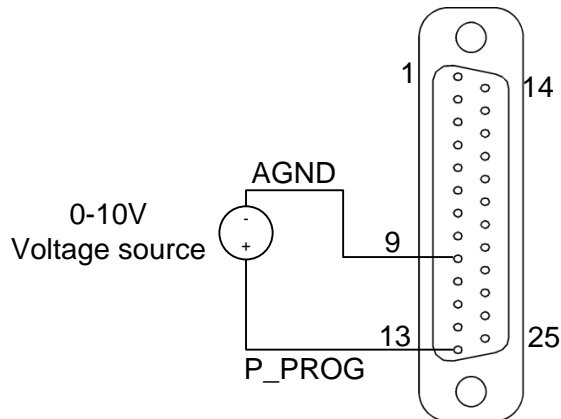

**Figure 3-16. Remote Power Programming Using 0-10 VDC Voltage Source (Digital Option Board only)**

## 3.7 REMOTE SENSING

Remote voltage sensing is recommended at all times, whether you connect sensing leads to the load or directly to the output terminals. Remote sensing at the load provides the best load regulation.

In applications where the load is located some distance from the power supply, or the voltage drop of the power output leads significantly interferes with load regulation, remote voltage sensing should definitely be used.

The voltage accuracy specifications are valid only with remote sense connected. Disconnecting the remote sense leads will introduce an error, with the output voltage increasing.

To use remote voltage sensing, connect the power supply as described below. See Figure 3-17 for connection requirements.

Connect sensing leads from the load positive to J3-1 and the load negative to J3-3. A shielded, twisted-pair, hookup wire is recommended to avoid potential noise interference.

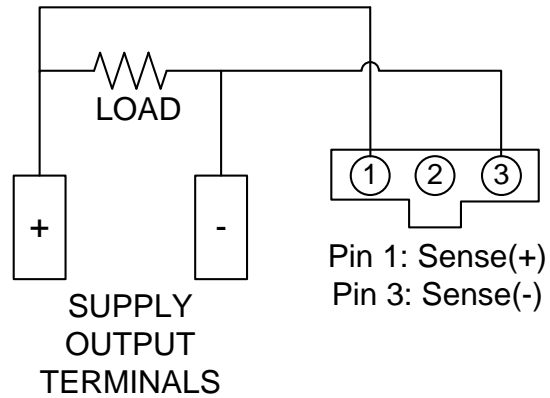

**Figure 3-17. Remote Sensing Operation at the Load**

### 3.8 REMOTE OUTPUT ON/OFF CONTROL

Remote output on/off control may be accomplished by contact closure or by an isolated external DC voltage source.

#### 3.8.1 REMOTE OUTPUT ON/OFF BY CONTACT CLOSURE

Output is on when contacts are closed. Connection requirements are as follows:

Terminals 14 and 17 on unit with digital option board (Figure 3-18)

Terminals 5 and 6 on unit with SG compatible option board (Figure 3-19)

Terminal 2 and 3 on unit with EtherCAT option board (Figure 3-20)

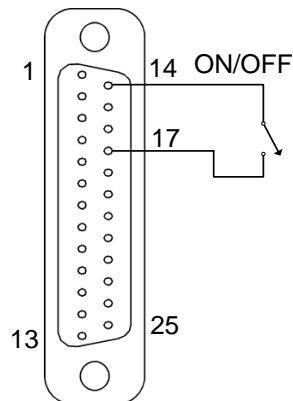

**Figure 3-18. Remote Output ON/OFF Control by Contact Closure (Digital Option Board)**

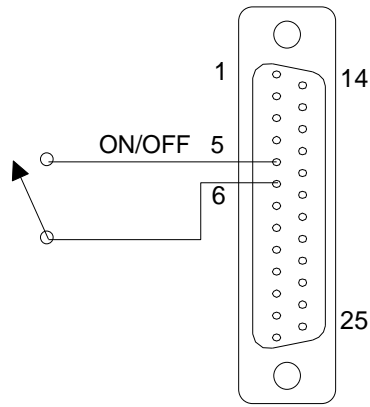

**Figure 3-19. Remote Output ON/OFF Control by Contact Closure (SG compatible Option Board)**

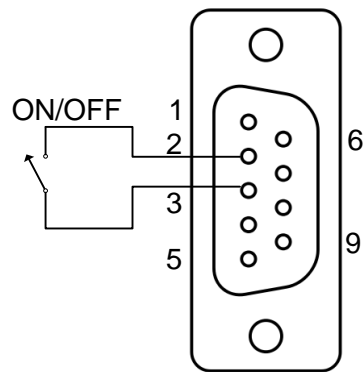

**Figure 3-20. Remote Output ON/OFF Control by Contact Closure (EtherCAT Option Board)**

## 3.9 PARALLEL AND SERIES OPERATION

The following modes of operation are used for applications requiring more current or voltage than is available from a single power supply. To meet the requirements for greater output voltage or current, two supplies may be connected in series (Section 3.9.3), or up to ten power supplies can be connected in parallel (Section 3.9.1).

Another option may be to connect an ASD unit with an SGA unit in parallel when requiring greater output current than a single power supply can provide (Section 3.9.2).

### 3.9.1 PARALLEL OPERATION

In order to connect up to ten power supplies in parallel, use a daisy-chain wiring configuration as follows (refer to Figure 3-21):

(Note that there are two separate RJ-45 connectors on the upper left rear panel of each power supply, marked INTERFACE #1 “PAR OUT” and “PAR IN”).

1. Beginning with the power supply designated (by you) to have the active master controller, use an interface cable (Shielded CAT 5 cable) to connect the PAR OUT connector on the designated active master controller to the PAR IN connector on the second power supply (unit 2).
2. On the second power supply (unit 2), use another interface cable to connect the PAR OUT connector to the third power supply's (unit 3) PAR IN connector. Continue these interconnections up to a maximum of 10 power supplies.
3. Install the bus termination on both ends of the group, the first and last unit, which are provided with the units. On the first unit install on “PAR IN” and on the last unit install on “PAR OUT” of INTERFACE #1.
4. Connect the Positive output terminals of all the power supplies and the Load.
5. Connect the Negative output terminals of all the power supplies and the load.
6. Confirm that there are no shorts between the Positive and Negative output terminals.
7. Referring to Figure 3-21, connect twisted pair cables as follows:

For **Remote** Sense, the active master controller shall have a twisted pair from its own SENSE terminals to the Load's output terminals.

For **Local** Sense, the active master controller shall have a twisted pair from its own SENSE terminals to its own output terminals.

Ensure that all twisted pair cables are as short as possible.

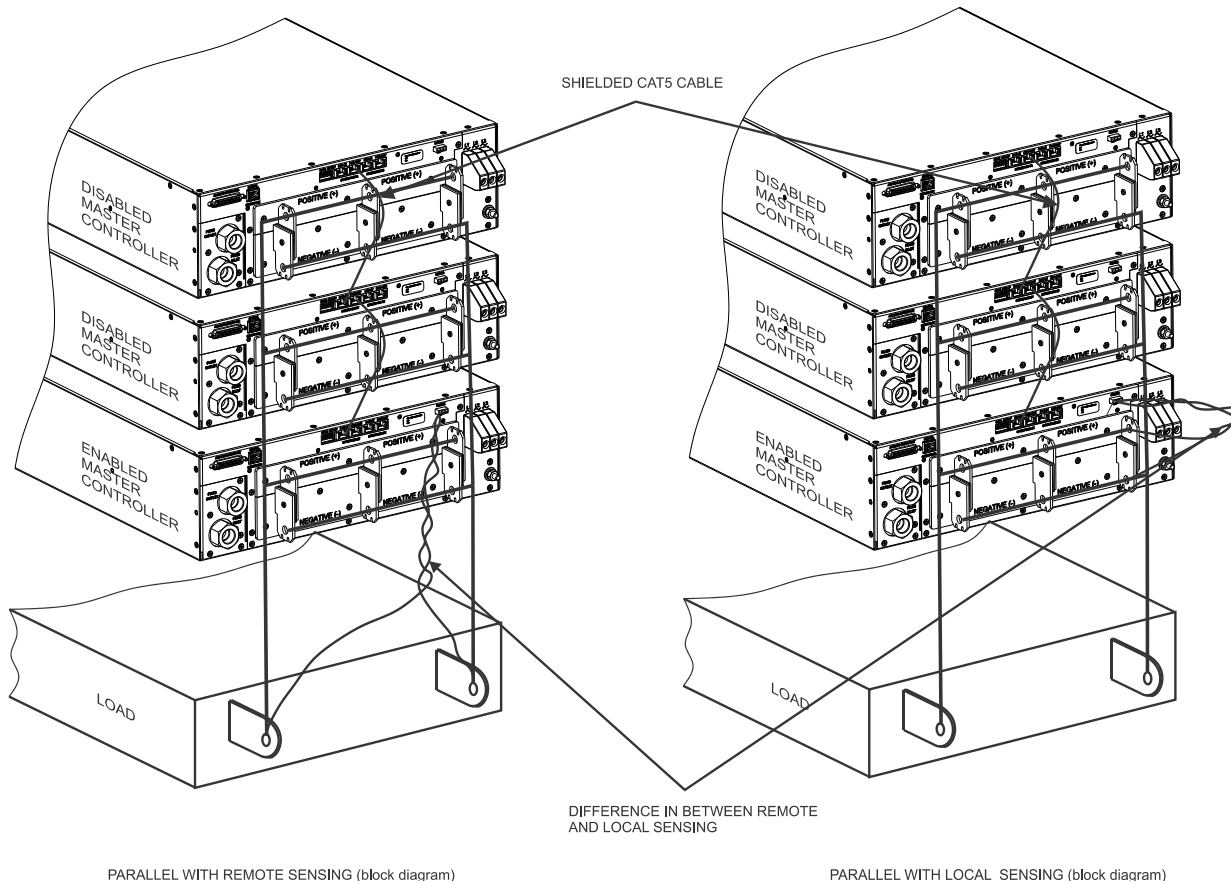

**Figure 3-21. Parallel and Remote/Local Sense Connections**

**Note:** The OVP circuit remains active for all units in parallel operation.

### 3.9.2 PARALLEL OPERATION WITH AN ASD UNIT AND AN SGA UNIT

The following modes of operation are used for applications requiring more current than is available from a single power supply. To meet the requirements for greater output current, two supplies may be connected in parallel.

In order to connect two power supplies in parallel, use a “Master/Slave” wiring configuration as follows (refer to Figure 3-22):

(Note that in ASD unit there is a 25-pin connector and on SG unit there are two separate 9-pin connectors on the upper left rear panel of each power supply, marked “ANALOG INTERFACE” and “PAR OUT” and “PAR IN” respectively).



1. Beginning with the ASD power supply designated as the Master power supply, use an interface cable (P/N 5551189-01) to connect the ANALOG INTERFACE connector on the ASD power supply to the PAR IN and PAR OUT connectors on the second power supply (Slave).
2. Connect the Positive output terminals of all the power supplies and the Load.
3. Connect the Negative output terminals of all the power supplies and the load.
4. Confirm that there are no shorts between the Positive and Negative output terminals.
5. Connect twisted pair cables as follows:

The **slave** unit shall have twisted pair from its SENSE terminals to its output terminals, as appropriate.

For **Remote Sense**, the master unit shall have a twisted pair from its own SENSE terminals to the Load's output terminals.

For **Local Sense**, the master unit shall have a twisted pair from its own SENSE terminals to its own output terminals.

Ensure that all twisted pair cables are as short as possible.

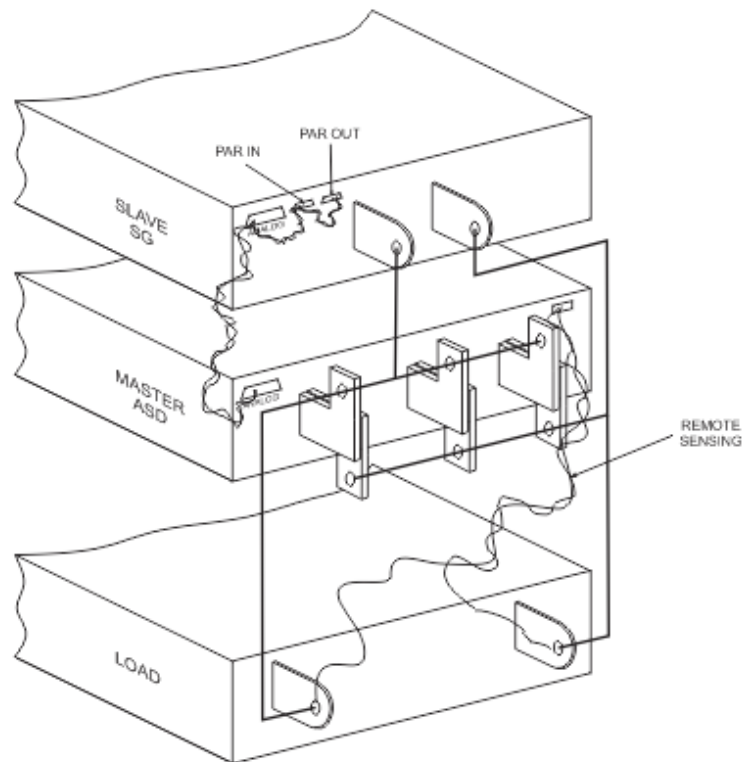

**Figure 3-22. Parallel and Remote Sense Connection of ASD as Master and SG as Slave**

**Note:** The OVP circuit remains active for all units in parallel operation. For ease of use, adjust the OVP level for the slave to maximum and adjust the master OVP level to the desired setting.

### 3.9.3 SERIES OPERATION

Series operation is used to obtain a higher voltage single output supply using two units. To set up series operation:

Connect the negative terminal (–) of one supply to the positive terminal (+) of the next supply of the same model. The total voltage available is the sum of the maximum voltages of each supply (add voltmeter readings).

**Notes:**

- Under no condition should the negative (–) output terminal of any power supply exceed 150V to Earth ground. This is limited by the creepage/clearance distances internal to the construction. If a higher output voltage range is required, contact the Sales Department or Customer Service for availability.
- The maximum allowable current for a series string of power supplies is the rated output current of a single supply in the string.
- Remote sensing should *not* be used during series operation.
- A free-wheeling diode (power diode capable of the maximum current of the series set connected in parallel, but reverse biased) is recommended to protect against sinking current into a supply should one supply be “ON” while the other is “OFF.” (See Section 2.7.1).

# **SECTION 4 PROGRAMMING: DIGITAL INTERFACE CONTROL**

## **4.1 INTRODUCTION**

This section covers the set up and remote operation of the ASD DC power supply, including a description of the digital interface, the registers, the communications interfaces, and the graphical user interface.

### **4.1.1 FEATURES**

The ASD advanced digital architecture includes:

- Real-time digital control
- Graphical display of signals, internal variable, and device status
- Advanced Diagnostics And Maintenance (ADAM)
- Choice of communications interface options:
- Ethernet TCP/IP with MODBUS-TCP protocol
- RS-485 half-duplex with MODBUS-RTU protocol
- Ethernet/IP
- EtherCAT

### **4.1.2 FUNCTIONS**

General functions of the digital interface include:

- Readback of:
- Outputs
- Status
- Warnings
- Faults
- Inputs for
- Enabling output

- Controlling setpoints
- Programming system shutdowns through selectable faults
- Monitoring load protection
- Controlling external processes

## 4.2 COMMAND REGISTERS

The power supply has two sets of registers, one for writing setpoints and configuration (read/write registers) and the other for reading unit and module status and measurements (read only registers). Each register is 16 bits wide.

### 4.2.1 READ/WRITE REGISTERS

Operating the power supply through the digital interface involves reading and writing data to a few important registers.

In the Command write register (address 0x0), enabling of the power supply's output is controlled by bit 1 (COMMAND\_BIT\_ON). Writing a "1" to this bit enables the output and writing a "0" disables the output.

In the Voltage, Current and Power write registers (addresses 0x1 – 0x6) setpoints are controlled and encoded in either 32-bit floating point when Command bit 7 is "1" or IQ15 fractional notation when Command bit 7 is "0". (IQ fractional notation of integer data: IQ15 means that the desired real value is multiplied by  $2^{15}$ , e.g., 0.5 = 16384 in IQ15).

#### HI REGISTER AND LO REGISTER

The voltage, current and power setpoints are 32-bit values and each uses two registers: HI and LO, where the most significant 16-bits are written to the HI register, and the least significant 16-bits are written to the LO register.

Voltage setpoint is programmed by writing data to the Vsetpoint\_HI/LO (addresses 0x1 – 0x2) write registers. In IQ15 this value is normalized so that 1.0 corresponds to a setpoint of full-scale voltage (60V / 40V). In floating point no normalization is required when writing the desired voltage value.

Current setpoint is programmed by writing data to the Isetpoint\_HI/LO write registers (addresses 0x3 – 0x4). In IQ this value normalized so 1.0 corresponds to the full-scale current of one module 167A / 250A. In floating point no normalization is required when writing the desired current value.

Power setpoint is programmed by writing data to the Psetpoint\_HI/LO write registers (addresses 0x5 – 0x6) will change the power setpoint. In IQ this value is normalized so that 1.0 corresponds to the full scale power of

one module 10020W / 10000W. In floating point no normalization is required when writing the desired power value.

## 4.2.2 READ ONLY REGISTERS

Read registers 0x0 and 0x3 - 0x8 are used to monitor the output and status of the power supply.

### READ OUTPUT REGISTERS

The voltage output is read using the Vout\_HI/LO read registers (0x3 – 0x4) and the encoding is the same as the Vsetpoint\_HI/LO write registers.

The current output of the power supply is read using the Ishunt\_HI/LO registers (0x5 – 0x6, same encoding as the Isetpoint HI/LO write registers).

The power output is read using the Pout\_HI/LO read registers (0x7 – 0x8, same encoding as Psetpoint\_HI/LO write registers).

### READ STATUS REGISTER

Reading the Status read register (0x0) returns the status of the power supply; it contains the output state, fault status and regulation mode of the power supply.

## 4.2.3 COMMAND WRITE REGISTERS

The command register has 12 bits that work independently with different functionality, described as follows (refer to Table 4-4):

Bit	Function
ON	Enables the output of the unit. Only when the output of the unit is enabled the power stages are active, otherwise they are totally off.
RESET FAULT	Clears all previous fault history when it is changed from a “0” to a “1”. After the faults are reset, the bit value will automatically change to “0”.
REMOTE SNS DISABLE	Disables remote sensing for the voltage loops, and also the monitors related to remote sensing (such as load cable impedance monitor).
ANALOG CURRENT	Defines analog inputs and outputs to Current or Voltage. When set to “1”, defines all analog input and outputs to current mode (4-20mA). If it equals “0”, the analog inputs and outputs are in voltage mode (0-10V).
IMPEDANCE MONITOR	Enables/disables the impedance monitor feature. When set to “1”, it enables the impedance monitor feature, which generates system faults when the output impedance or load cable impedance do not meet certain requirements. (Section 4.3.3)
MODBUS TIMEOUT	Monitors MODBUS activity. When set to “1”, the master controller monitors periodic Modbus activity, with a pre-defined maximum period of inactivity. If there is no activity after that period, a fault is generated to indicate a possible issue with the MODBUS interface or the

Bit	Function
	controller. (Section 4.3.5).
FLOATING POINT ENABLED	Controls whether 32-bit numbers are floating point or integer. When set to “1”, all 32-bit numbers are floating point numbers (IEEE single precision standard). When set to “0”, all 32-bit numbers are integer numbers with a scale given specified in the register list of this document.
FDR ENABLED	Activates the flight data recorder option. When set to “1”, the master controller and modules controllers periodically save certain information to internal non-volatile memory for later diagnostics. (Section 4.3.6).
RESET ENERGY METER	Causes the cumulative energy meter to restart at zero. When changed from “0” to “1”, the energy meter accumulator is reset.
ANALOG VOLTAGE OVERRIDE	Only applicable in analog programming mode when unit is to be operated in current and/or power mode only, use this bit to ignore analog voltage programming input. When set to “1”, the analog voltage programming input is ignored and the voltage setpoint is set to maximum.
ANALOG CURRENT OVERRIDE	Only applicable in analog programming mode when unit is to be operated in current and/or power mode only, use this bit to ignore analog current programming input. When set to “1”, the analog current programming input is ignored and the current setpoint is set to maximum.
ANALOG POWER OVERRIDE	Only applicable in analog programming mode when unit is to be operated in current and/or voltage mode only, use this bit to ignore analog power programming input. When set to “1”, the analog power programming input is ignored and the power setpoint is set to maximum.
DIGITAL PROGRAMMING MODE	Tells the unit to receive setpoints from the digital interface or from the analog interface. When set to “1”, the unit will receive setpoints from the digital interface (digital programming mode*). If set to “0”, the setpoints are taken from analog interface (analog programming mode). *In digital programming mode, the output enable signal at the analog interface must be set to high in order for the unit to turn on without a fault.
PROCESS CONTROL MODE	Controls an external process. When set to “1”, the unit is set to control an external process, using the power programming analog input as the feedback. (Section 4.3.8).
DISABLE ANALOG SATURATION	Only applicable in analog programming mode, when set to “1” and any of the 3 ANALOG OVERRIDE bits is used, the setpoint used for that variable is not saturated to maximum; but is taken from the digital interface setpoint (e.g. register).

## **4.3 ADVANCED DIGITAL CONTROL FEATURES**

### **4.3.1 SETPOINTS**

ASD power supplies series have 3 modes of operation: voltage, current and power mode. There are 3 analog inputs called programming inputs that define the setpoints when analog programming mode is used. There are 3 registers that define the setpoints when digital programming is used (see DIGITAL PROGRAMMING MODE bit in the command register).

In analog programming mode, the setpoint registers are automatically updated with the values of the analog inputs. Writing to them has no effect.

If a value beyond the limits is written to the setpoint registers, the actual written value is saturated to the maximum limit. For example, if a 100V setpoint is written to a 60V unit, the actual written value will be 60V.

### **4.3.2 REMOTE VOLTAGE SENSING**

ASD units have both local and remote voltage sensing capabilities. Remote sensing allows closing the voltage loop right at the load terminals, compensating for load cable voltage drops. The maximum remote sensing compensation is 50% of full scale voltage, giving up to 2% extra voltage (on top of the nominal voltage rating) in case it is needed. Having local and remote sensing allows also monitoring load cable voltage drop and impedance, in order to detect load cable or connection issues.

Maximum accuracy of the voltage measurement is obtained by using remote sensing.

### **4.3.3 LOAD IMPEDANCE MONITOR**

The load impedance monitor feature performs a calculation in real time of the load impedance, based on the output voltage and current measurements. If the output impedance monitor is enabled ("IMPEDANCE MONITOR" bit in the command register), the load impedance calculation is continuously compared to programmable maximum and minimum values. If the output impedance falls outside this window, a "FAULT\_OUTPUT\_IMPEDANCE" fault will be generated, which can shut down the unit if desired (see Programmable Fault Behavior).

ASD units also monitor how the load impedance changes with time, which is called impedance "rate-of-change" (ROC). This is intended to show sudden changes in impedance caused by failures, as opposed to the typically slow changes in impedance caused by temperature changes of the load. There is also a maximum limit and a minimum limit for this variable, specified in percent of change per second. If the rate of change is outside this window, the master controller will generate a fault.

#### **4.3.4 DEFAULT REGISTER SAVING**

By using the “Save\_Defaults” register, all the contents of the Write registers are saved to non-volatile memory. Every time the unit powers on, these saved registers are loaded.

In case the original factory values are required, a different command code can be used to recall them.

The command codes are the following:

- 0x1234: stores current state as default.
- 0x5678: restores saved default.
- 0x9ABC: restores factory defaults.

After writing a command to the “Save\_Defaults” register, this same register should read 0x1111 to confirm that the previous command was successfully executed.

#### **4.3.5 MODBUS TIMEOUT**

In order to prevent the unit from working in open loop in case of failure of the process controller or analog/digital communications link, the ASD master controller can monitor the Modbus activity.

If there is no activity for a given (programmable) time, the unit will generate a fault and automatically shut down if desired.

To activate this feature, bit “MODBUS TIMEOUT” in the command register has to be set to “1”. The timeout time is set by the “Modbus\_timeout\_period” register.



### 4.3.6 FLIGHT DATA RECORDER (FDR)

All ASD controllers (master controller and individual module controllers) have a local non-volatile memory that allows the microprocessor to save relevant operating variables after certain events and/or at a programmable period controlled by the active master controller.

The data stored in the Flight Data Recorder (FDR) of the master controller are shown in Table 4-1, the module data are shown in Table 4-2.

**Table 4-1. Master Controller FDR Data**

Word size (bits)	Variable
16	header
24	date/time
16	command_register
8	status
8	existing_modules
32	fault_bits
32	supervisory_warning
32	supervisory_fault
32	Vsetpoint
32	Isetpoint
32	Vmonitor
32	Imonitor
32	Vsns_drop
32	Zout_ROC_max
32	energy_meter
32	modules_active
32	modules_warning
32	modules_fault

**Table 4-2. Module Controller FDR Data**

<b>Word size (bits)</b>	<b>Variable</b>
16	header
24	date/time
16	time_increment
16	module_status
32	supervisory_warning
32	supervisory_fault
16	Vsetpoint
16	Isetpoint
16	Vout
16	Ishunt
16	Vout_max
16	Ishunt_max
16	Vdcbus
16	Vin_peak
16	controller
16	CT_LS
16	Vbias
16	Ibias
16	Tamb
16	Tshunt
16	Tmosfets
16	Tdiodes
16	Txfmr
16	Vhotwire
16	fan_speed
16	spare_time

**PERIODIC DATA RECORDING**

A snapshot of the data is saved periodically at a period programmed by the register “FDR\_Period”, and also when a local warning or fault is generated. The master controller has a real time clock (optional) that keeps track of the date and time, so every entry is logged with this time information. If the “FDR\_ENABLED” is set to “1”, the master controller sends a periodic request to all to modules to save their local data to their FDR memories. If any module has a local fault, it will immediately save it to its local FDR with the last time information received from the master plus a “time\_increment”, specified in seconds.

Contact Customer Service for the necessary AMETEK software to download the stored FDR information.

### 4.3.7 PROGRAMMABLE FAULT BEHAVIOR

Fault behavior can be programmed to either report a specific fault and shut down the power supply output, or report the fault and continue running the power supply output. A 32-bit register called “Fault\_Shutdown\_Config\_HI/LO” defines this behavior. See Table 4-11 for bit descriptions of the Fault Bits Register.

If a given bit is set to “1”, this means that the particular fault described in the “Fault\_Bits register bit description” will produce a unit shut down.

Some faults are not editable and will always produce a unit shut down (writing zeros does not change their behavior), because they are related to hard faults that may affect the integrity of the system.

### 4.3.8 EXTERNAL PROCESS CONTROL

ASD power supplies have the capability of controlling external variables, such as temperature or pressure, by using an internal PID compensator and an analog input for the feedback. Figure 4-1 shows a block diagram of an ASD unit controlling an external process. The main parts are:

- |                    |  |
|--------------------|--|
| <b>Feedback</b>    | The feedback of the controlled variable comes from the external process and is fed to the ASD controller by using one of the analog inputs (the power programming input). With the right transducer, any external variable can be controlled by the power supply, such as temperature, pressure, current, voltage, position, etc. The only requirement is that the transducer has to produce an analog signal compatible with the analog inputs of the ASD interface (0-10V or 4-20mA).  |
| <b>Setpoint</b>    | The setpoint of the process controller can be taken from the digital interface (Psetpoint register) or from the analog interface (Vprog input), depending on the configuration in the “Process_config” register. See Table 4-7 for more details.   |
| <b>Compensator</b> | The calculated error between the setpoint and the feedback feeds a compensator, which is implemented as a discrete 2-pole 2-zero stage. The most common way to calculate these coefficient is starting from a PID (proportional-integral-derivative) stage, and calculating the 2-pole 2-zero coefficients based on it. The five coefficients (Process_coef_0 thru 4) can be programmed by using write registers 51 to 60 (see Table 4-4). The compensator is executed by the master controller at a sampling rate of 125Hz. The feedback and setpoint variables have a range of 0 to 1.0. |
| <b>Command</b>     | The compensator generates a command that can be configured to control the output voltage or current of the power supply. This is configured by a bit in the “Process_config” register. See Table 4-7 for more details.   |

**Process Limit**  
(only in analog programming mode)

If desired, the maximum output (current or voltage) generated by the process control loop can be limited by an analog input (Iprog input). This is configured by a bit in the “Process\_config” register. See Table 4-7 for more details. If the unit is in digital programming mode, the maximum voltage and current outputs are controlled by the Vsetpoint and Isetpoint registers.

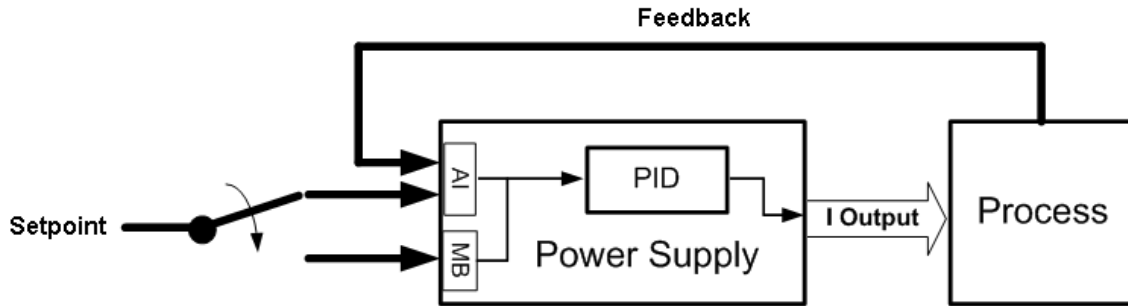

**Figure 4-1. Block Diagram, External Process Control Feature**

### 4.3.9 PROGRAMMABLE FULL-SCALE SETTING

There are two registers called “Ilimit” and “Vlimit” to artificially define the “full-scale” range and scale of the power supply setpoints. These registers can be programmed with values lower or higher than the actual power supply full-scale current and voltage. The registers have two effects:

- Analog ports scale (programming inputs and monitor outputs): 0 to 10V (or 4 to 20mA) represents 0 to Ilimit (or 0 to Vlimit) instead of 0 to full-scale values.
- Saturation limit of digital programming: the master controller will saturate the programmed setpoints to the values in Ilimit and Vlimit.

If this feature is not used (default), a value of 0 has to be programmed.

For example, a 60V power supply can have Vlimit = 50V and 0-10V means 0-50V output. If Vlimit is higher than 60V, the power supply will generate a COMMAND\_ERROR fault (see Table 14) if it is actually programmed with a value higher than 60V.

### 4.3.10 QUERYING MODULE INFORMATION

Certain module information can be accessed through the master controller digital interface by using the module query register.

The write register “Query\_Module” has to be written with the module address number in the most significant 8 bits, and with a command number in the least significant 8 bits. Table 6 shows the possible data that

can be accessed by using different command numbers. After the “Query\_Module” register is written with the 2 number, the master controller will communicate with the module to obtain the data and will make it available at the read register “Module\_Query\_Info\_HI/LO”.

Read registers at addresses 100 to 131 have the discovered module bus addresses required to query the module, they are sorted from lower address to higher.

To summarize, the sequence to read module information is:

1. Find the module bus address in registers 100 to 131.
2. Write the “Query\_Module” register with the module address and the desired command number.
3. After a few milliseconds, read the data from the “Module\_Query\_Info\_HI/LO” register.

**Table 4-3. Module Data Query Commands**

Command number	Module data
0	Module ID
1	Firmware version
2	Serial number
3	Module status
4	Supervisory fault
5	Supervisory warning

#### **4.3.11 PROGRAMMABLE SLEW-RATE LIMIT**

The slew-rate of the output voltage and/or current can be controlled when the setpoints change. There are two 32bit registers, “Vsetpoint\_SRL\_HI/LO” and “Isetpoint\_SRL\_HI/LO”, that limit in V/ms and A/ms the speed of change of the voltage and current setpoints. If sudden changes in the setpoints are applied through analog or digital interface, the master controller limits the slew-rate to the programmed limits.

#### **4.3.12 PROGRAMMABLE LOW-PASS-FILTERS**

The master controller applies a low pass filter (LPF) to the monitor signals before making them available at the analog port and the read registers. This LPF can be programmed to respond slower in case the load is not constant and the average variables want to be monitored.

The digital low pass filters implemented in the master controller are single-pole, and can be programmed with the alpha ( $\alpha$ ) coefficient, given by:

$$\alpha = 1/(f_c * 2\pi) / (1/(f_c * 2\pi) + 1/f_s)$$

Where  $f_c$  is the desired cut off frequency, and  $f_s$  is the sampling rate of the digital filter, which is 125Hz for the master controller.

The two low pass filters that can be programmed in the ASD unit are monitor signals and impedance calculation.

- Monitor signals (“monitor\_alpha\_HI/LO” register) is used for Vmonitor, Imonitor and Pmonitor.
- Impedance calculation (“Z\_alpha\_HI/LO” register) is used for output impedance calculations.

### **4.3.13 EXPECTED NUMBER OF MODULES FEATURE**

When this feature is enabled (switch #8 UP or from the digital interface) the master will expect to discover a predefined number of modules. If the number of modules is lower than the expected, the unit will generate a fault indicating that there may be a problem with one or more modules. This feature also fixes the analog interface scale based on the expected number of modules, making it independent from the actual number of modules that were discovered.

For example, if in a 60V unit the predefined number of modules is 6 (switches 6 and 4 UP), the total available output current with 6 modules would be 1000A, so the analog interface full scale (10V or 20mA) would be 1000A regardless of the actual number of connected modules. If there are 3 discovered modules because the 2nd chassis was not powered-up, the analog interface scale will be fixed based on the EXPECTED number of modules, and the master will generate a fault because there were too few discovered modules.

If this feature is not used, the actual number of modules discovered by the master will define the analog interface scale. For example, three 60 V modules give 500 A full scale, or six 60 V modules give 1000 A.

## **4.4 LIST OF REGISTERS**

This section presents the following tables of registers:

- Write Registers, Table 4-4
- Command Register Bits, Table 4-5
- FDR\_Period Register Bits, Table 4-6
- Process\_Config Register Bits, Table 4-7
- EtherCAT\_Config Register Bit, Table 4-8
- Read Registers, Table 4-9
- Status Register Bits, Table 4-10
- Fault\_Bits Register, Table 4-11
- Module\_Information Register Bits, Table 4-12

**Table 4-4. Write Registers**

Address	Name	IQ	Content	Notes
0	Command	binary	See Command description below.	
1, 2	Vsetpoint_HI/LO	IQ15 / FP	Output voltage setpoint. 1.0 = nominal voltage (60V / 40V).	2, 3
3, 4	Isetpoint_HI/LO	IQ15 / FP	Output current setpoint. 1.0 = nominal current of one module (167A / 250A).	2, 3
5, 6	Psetpoint_HI/LO	IQ15 / FP	Output power (or process) setpoint. 1.0 = nominal power of one module (10020W / 10000W).	2, 3
7, 8	Module_Vout_peak_HI/LO	IQ15 / FP	Overvoltage protection threshold. 1.0 = nominal voltage (60V / 40V).	2, 3
9, 10	Zoutput_Max_HI/LO	IQ24 / FP	Output impedance max limit. 1.0 = (nominal voltage / nominal current) of one module (0.3593Ω / 0.1600Ω).	2, 3
11, 12	Zoutput_Min_HI/LO	IQ24 / FP	Output impedance min limit. 1.0 = (nominal voltage / nominal current) of one module (0.3593Ω / 0.1600Ω).	2, 3
13, 14	Zoutput_ROC_Pos_HI/LO	IQ20 / FP	Output impedance rate-of-change max limit. Percent of change per second.	2, 3
15, 16	Zoutput_ROC_Neg_HI/LO	IQ20 / FP	Output impedance rate-of-change min limit. Percent of change per second.	2, 3
17, 18	Fault_Shutdown_Config_HI/LO	binary	All bits that are "1" will cause the corresponding fault bit to generate a shutdown the unit.	3, 4
19, 20	Zcable_Max_HI/LO	IQ24 / FP	Cable impedance max limit. 1.0 = (nominal voltage / nominal current) of one module (0.3593Ω / 0.1600Ω).	2, 3
21, 22	Vdrop_Cable_Max_HI/LO	IQ15 / FP	Cable voltage drop max limit. 1.0 = nominal voltage (60V / 40V).	2, 3
23, 24	Zmonitor_Imin_HI/LO	IQ15 / FP	Impedance monitor minimum required current. 1.0 = (nominal voltage / nominal current) of one module (0.3593Ω / 0.1600Ω).	3
25, 26	Zalpha_HI/LO	IQ24 / FP	Alpha coefficient of the low pass filter for all impedance calculations. Normalized (0 to 0.9999).	3
27	Save_Defaults	binary	0x1234 stores current state as default, 0x5678 restores saved default, 0x9ABC restores factory defaults.	
28	Query_Module	binary	Used to query module data, in combination with Read registers 29, 30 (Query_Module_Info).	
29	Expected_Modules	Int16	If non-zero a fault will be generated when existing modules does not match this value. See user guide for more details.	
30	FDR_Period	Int16	See FDR_Period description below for more information.	
31, 32	Vsetpoint_SRL_HI/LO	IQ15 / FP	Voltage setpoint slew-rate-limit. 1.0 = nominal voltage (60V / 40V) per ms voltage setpoint rate-of-change limit.	2, 3
33, 34	Isetpoint_SRL_HI/LO	IQ15 / FP	Current setpoint slew-rate-limit. 1.0 = nominal current of one module (167A / 250A) per ms current setpoint rate-of-change limit.	2, 3
35, 36	monitor_alpha_HI/LO	IQ24 / FP	Alpha coefficient of the low pass filter for the monitor readbacks. Normalized (0 to 0.9999).	2, 3
37, 37	max_delta_setpoint_HI/LO	IQ15 / FP	Used for impedance calculation. If setpoints change more than this value the impedance measurement is considered not valid. Percent per ms.	2, 3
39	Z_delay	Int16	Used for impedance calculation. Time delay after the impedance calculation is considered valid again. 1 is equivalent to 8 ms of delay	
40	Modbus_timeout_period	Int16	Used with Modbus timeout feature. 1 is equivalent to 8 ms of delay	
41, 42	activation_code_HI/LO	Int32	Code to unlock the digital interface. A value of all ones ( 4294967295) will lock it. The correct unlock code is based on an encryption algorithm and the Master Controller serial number.	3

Address	Name	IQ	Description	Notes
43, 44	Vlimit_HI/LO	IQ15 / FP	Artificial limit of voltage setpoint. Changing this value will change the scaling of the analog inputs and outputs. 1.0 = nominal voltage (60V / 40V).	
45, 46	Ilimit_HI/LO	IQ15 / FP	Artificial limit of current setpoint. Changing this value will change the scaling of the analog inputs and outputs. 1.0 = nominal current of one module (167A / 250A).	
47	Time_hi	Int16	Real time clock time in BCD	
48	Time_md	Int16	Real time clock time in BCD	
49	Time_lo	Int16	Real time clock time in BCD	3
50	Process_config	binary	Used to configure process control feature	
51, 52	Process_coef_0	FP	Coefficient B2 of 2P/2Z compensator for process control	
53, 54	Process_coef_1	FP	Coefficient B1 of 2P/2Z compensator for process control	
55, 56	Process_coef_2	FP	Coefficient B0 of 2P/2Z compensator for process control	3
57, 58	Process_coef_3	FP	Coefficient A2 of 2P/2Z compensator for process control	
59, 60	Process_coef_4	FP	Coefficient A1 of 2P/2Z compensator for process control	
61	Ethercat_config	binary	Used to configure EtherCAT interface (disable)	

**Notes:**

1. All the registers have integer data. IQ means fractional notation:
  - o IQ15 means that the desired real value has to be multiplied by  $2^{15}$ , for example 0.5 equals to 16384 in IQ15.
  - o IQ10 means that the desired real value has to be multiplied by  $2^{10}$ .
2. 32-bit registers are composed of two 16-bit registers, HI (16 MSB) and LO (16 LSB)
3. See Fault\_Bits for the bit codes and descriptions.

For a 3-module unit, the maximum voltage is 1.0, the maximum current is 3.0 and the maximum power is 3.0.



**Table 4-5. Command Register Bits**

Bit	Field	Value	Description
1	ON	0 1	Turns off the unit. Turns on the unit.
2	RESET_FAULT	0 1	No action. Resets any faults.
3	REMOTE_SNS_DISABLE	0 1	Enables remote voltage sensing. Disables remote voltage sensing.
4	ANALOG_CURRENT	0 1	Analog voltage programming mode. Analog current programming mode.
5	IMPEDANCE_MONITOR	0 1	Disables output impedance monitoring. Enables output impedance monitoring.
6	MODBUS_TIMEOUT	0 1	Disables monitoring of Modbus activity. Enables monitoring of Modbus activity.
7	FOATING_POINT_ENABLED	0 1	Fractional register values use 32-bit IQ fractional encoding. Fractional register values use 32-bit floating point encoding.
8	FDR_ENABLED	0 1	Flight Data Recorder periodic update disabled. Flight Data Recorder periodic update enabled.
9	RESET_ENERGY_METER	0 1	No action. Resets the energy meter to zero.
10	ANALOG_VOLTAGE_OVERRIDE	0 1	Analog Interface voltage set via external current or voltage signal. Analog Interface voltage input disabled.
11	ANALOG_CURRENT_OVERRIDE	0 1	Analog Interface current set via external current or voltage signal. Analog interface voltage input disabled.
12	ANALOG_POWER_OVERRIDE	0 1	Analog Interface power set via external current or voltage signal. Analog Interface power input disabled.
13	DIGITAL PROGRAMMING MODE	0 1	Setpoints are taken from analog programming inputs. Setpoints are taken from digital interface.
14	PROCESS CONTROL MODE	0 1	Standard modes: voltage/current/power. Process control is active, modes: voltage/current/process.
15	DISABLE ANALOG SATURATION	0 1	Disabled analog inputs (bits 10, 11, 12) saturate to max setpoint. Disabled analog inputs take setpoint from digital programming.
16	Not used		

**Table 4-6. FDR\_Period Register Bits**

Bit	Field	Description
1-12	FDR_Update_Period	Integer number of seconds between FDR periodic updates when the unit's output is enabled.
13 - 16	FDR_Decimation	Module Vin scope capture decimation (scope frequency = 100,000 Hz / 2 ^ FDR_Decimation).

**Table 4-7. Process\_Config Register Bits**

Bit	Field	Description
1	Setpoint_Select	Process loop setpoint source: digital setpoint=1, analog setpoint=0
2	Output_Select	Process output command parameter: voltage=1, current=0
3	Limit_Active	If equal to "1", the process limit signal using analog_lsetpoint is active

**Table 4-8. EtherCAT\_Config Register Bit**

Bit	Field	Description
1	EtherCAT_Write_Disable	If equal to "1", the controller ignores any EtherCAT modification to write registers

**Table 4-9. Read Registers**

Address	Name	IQ	Description	Notes
0	Status	n/a	Describes the status of the unit (output enabled, faults, mode, etc). See register description below	
1, 2	Fault_Bits_HI/LO	binary	Ssystem fault bits, each bit of the number means a different fault. See fault bits description.	3
3, 4	Vmonitor_HI/LO	IQ15 / FP	Output voltage monitor. 1.0 = nominal current of one module (167A / 250A)	1, 2
5, 6	Imonitor_HI/LO	IQ15 / FP	Output current monitor. 1.0 = nominal voltage (60V / 40V)	1
7, 8	Pmonitor_HI/LO	IQ15 / FP	Output power/process monitor. 1.0 = nominal power of one module (10020W / 10000W)	1, 2
9	Existing_Modules_Qty	Int16	Number of modules that are recognized by the unit. Depends on the number of modules that were discovered by the master controller.	
10	Active_Modules_Qty	Int16	Number of modules recognized by the master as active (functional).	
11, 12	Modules_Active_HI/LO	binary	Bits in "1" indicate that the corresponding modules are active	2
13, 14	Modules_Fault_HI/LO	binary	Bits in "1" indicate that the corresponding modules have faults	2
15, 16	Modules_Warning_HI/LO	binary	Bits in "1" indicate that the corresponding modules have warnings	2
17, 18	Zoutput_HI/LO	IQ24 / FP	Load impedance monitor. 1.0 = (nominal voltage / nominal current) of one module (0.3593Ω / 0.1600Ω)	1, 2
19, 20	Zoutput_ROC_HI/LO	IQ20 / FP	Load impedance rate-of-change monitor. Percent change per second.	1, 2
21, 22	Master_ID_HI/LO	binary	Hardware configuration of the master controller, used to identify the unit type.	2
23, 24	Serial_Number_HI/LO	Int32	Serial number of the master controller.	2
25, 26	ZCable_HI/LO	IQ15 / FP	Load cable impedance monitor. Only valid if remote sensing is enabled. 1.0 = (nominal voltage / nominal current) of one module (0.3593Ω / 0.1600Ω)	1, 2
27, 28	VDrop_Cable_HI/LO	IQ15 / FP	Load cable voltage drop monitor. Only valid if remote sensing is enabled. 1.0 = nominal voltage (60V / 40V)	1, 2
29, 30	Module_Query_Info_HI/LO	binary	Used to read module data, in combination with Write register 28 (Query_Module).	2
31, 32	Energy_Meter_HI/LO	Int32	Cumulative counter of energy supplied by the unit (1 = kW • s).	2, 5
33	Firmware_Version	binary	Indicates the current firmware version of the master controller.	
34	Modbus_status	binary	Indicates the status history of the Modbus communication. Used for debugging Modbus communication.	
35, 36	Unit_Serial_Number_HI/LO	Int32	Serial number of the unit.	
37, 38	Master_Supervisory_Faults_HI/LO	binary	Master controller supervisory fault bits, each bit of the number means a different fault. See fault bits description.	
39, 40	Master_Supervisory_Warnings_HI/LO	binary	Master controller supervisory warning bits, each bit of the number means a different warning. See fault bits description.	
100 - 131	Module_Info	binary	Used to obtain information on connected modules, see register description below.	4
500 - 510	Unit_PN	char	Stores a string with the part number of the unit.	

Notes:

4. All the registers have integer data. IQ means fractional notation:
  - IQ15 means that the desired real value has to be multiplied by  $2^{15}$ , for example 0.5 equals to 16384 in IQ15.
  - IQ10 means that the desired real value has to be multiplied by  $2^{10}$ .
5. 32-bit registers are composed of two 16-bit registers, HI (16 MSB) and LO (16 LSB)
6. See Fault\_Bits for the bit codes and descriptions.
7. See Module\_Information for description of the bits used.
8. Energy meter can be reset using Command register bit 9.

**Table 4-10. Status Register Bits**

Bit	Field	Value	Description
1	STATUS_BIT_ON	0 1	The unit is off. The unit is on.
2	STATUS_BIT_FAULT	0 1	No faults. There is a fault.
3	STATUS_BIT_ANALOG_PROG	0 1	The unit is not enabled through analog programming. The unit is enabled through analog programming.
4	STATUS_BIT_MODBUS_PROG	0 1	The unit is not enabled through Modbus programming. The unit is enabled through Modbus programming.
5	STATUS_BIT_IMODE	0 1	The unit is not in current mode. The unit is in current mode.
6	STATUS_BIT_VMODE	0 1	The unit is not in current mode. The unit is in voltage mode.
7-16	Not used		

**Notes:**

1. If both voltage and current mode signals are "1" this indicates that the unit is in power/process mode.
2. The fault bit will stay high until the Command register COMMAND\_BIT\_RESET\_FAULT bit is set to "1".
3. In case of a fault, the Fault\_Bits will show the reason of the fault with an error code. Each fault is indicated by one bit so that multiple faults can be indicated simultaneously. Use the Fault\_Bits descriptions below to decode which fault(s) are being annunciated.

**Table 4-11. Fault\_Bits Register**

Code	Name	Description
0x1	FAULT_MODULE_FAULT	One or more modules have reported a fault.
0x2	FAULT_OUTPUT_IMPEDANCE	The output impedance has exceeded the maximum or is below of minimum limit.
0x4	FAULT_COMMAND_ERROR	The unit reports that it cannot accomplish with the programmed current, voltage and power.
0x8	FAULT_MASTER_HARD_FAULT	The master board has detected a hardware fault.
0x10	FAULT_MASTER_SUPERVISORY	The master board has detected a fault in the variables of supervision.
0x20	FAULT_ANALOG_PSETPOINT	When using 4-20mA analog programming, this signal indicates that the input current is below 2mA. This may indicate an external problem with the 4-20mA loop.
0x40	FAULT_ANALOG_ISETPOINT	
0x80	FAULT_ANALOG_VSETPOINT	
0x100	FAULT_REMOTE_SNS_ERROR	There is too much measurement error in remote sensor. This may indicate an external problem with the remote sensing cable.
0x200	FAULT_MODBUS_TIMEOUT	No Modbus communication activity has been detected. This may indicate an external problem with the master Modbus device.
0x400	FAULT_MASTER_WARNING	The master board has detected a warning in the variables of supervision.
0x800	FAULT_NO_RESPONSE_MODULE	One or more modules did not respond to the internal communication.
0x1000	FAULT_REPEATED_MODULE_ID	The master has more than one module connected with the same ID value.
0x2000	FAULT_TOO_MANY_MODULES	The master is connected to more than the maximum of 32 modules. This may indicate that too many power supplies are connected in parallel.

Code	Name	Description
0x4000	FAULT_REPEATED_MODULE_SERIAL	The master has more than one module ID with the same serial number.
0x8000	FAULT_OUTPUT_IMPEDANCE_ROC	The output impedance rate of change has exceeded the maximum limit.
0x10000	FAULT_LOAD_CABLE_IMPEDANCE	The load cable impedance has exceeded the maximum limit.
0x20000	FAULT_TOO_FEW_MODULES	The master is connected to less than the expected number of modules. See user guide for more details.
0x40000	FAULT_MISSING_PHASE	There is a phase missing from the AC input to the unit.
0x80000	FAULT_ANALOG_SHUTDOWN	Output enable pin at the analog port is not enabled and the unit was enabled through digital interface.
0x100000	FAULT_ANALOG_PRG_IN_OVERLOAD	One of the analog programming inputs was overloaded with too high current or voltage.

**Table 4-12. Module Information Register Bits**

Bit	Field	Description
1 - 12	MODULE_BUS_ADDRESS	Contains the unique module bus address used for communications with that module
13 - 16	Not used	

## 4.5 MODBUS COMMUNICATIONS

The Modbus protocol specification can be downloaded from [www.modbus.org](http://www.modbus.org). The following is a brief description of Modbus protocol taken from the same website:

“Modbus is an application-layer messaging protocol, positioned at level 7 of the OSI model. It provides client/server communication between devices connected on different types of buses or networks.

The de facto industrial serial standard since 1979, Modbus continues to enable millions of automation devices to communicate. Today, support for the simple and elegant structure of Modbus continues to grow. The Internet community can access Modbus at a reserved system port 502 on the TCP/IP stack.

Modbus is a request/reply protocol and offers services specified by function codes. Modbus function codes are elements of Modbus request/reply PDUs. This protocol specification document describes the function codes used within the framework of Modbus transactions.”

### 4.5.1 ETHERNET – MODBUS-TCP

The Ethernet port is configurable for either Modbus TCP (default) or Modbus RTU which is transmitted and received using an internal Lantronix XPort-04 Ethernet TCP/IP server. For more details on the XPort-04 see the XPort User Guide at the manufacturer's website.

The Ethernet digital interface is shipped DHCP-enabled using port 502 for Modbus communications. There is a label on the back of each unit with the XPort MAC Address for acquiring the IP Address of the unit. Information for reconfiguring the XPort-04 Ethernet settings can be found in the XPort User Guide found at the above link to the manufacturer's website. Do not modify the XPort-04 serial settings because this may cause an internal loss of digital communications.

### 4.5.2 SERIAL – MODBUS-RTU

The serial interface uses RS-485 half-duplex serial communications with the following configuration for carrying the Modbus RTU data:

- Baud rate: 230,400 bps
- Flow control: none
- Data bits: 8
- Parity: none
- Stop bits: 2

The RJ-45 connector for the Serial Interface uses the Modbus Interface standard pin-out ([www.modbus.org](http://www.modbus.org)). This is shown in Table 4-13

**Table 4-13. Pin-out of the RJ45 Serial Port**

Pin	Signal
1-3	n/u
4	RS485_B
5	RS485_A
6	n/u
7	24V
8	Ground
Shield	Chassis Ground

### 4.5.3 ETHERNET/IP INTERFACE

EtherNet/IP (Ethernet Industrial Protocol) is a communications protocol developed by Rockwell Automation, managed by the Open DeviceNet Vendors Association (ODVA) and designed for use in process control and other industrial automation applications.

ASD power supplies internally use an Ethernet/IP device called NET485-EIP-MB. This device converts Ethernet/IP protocol to Modbus protocol, which is described in previous sections of this manual.

The interface expects a BOOTP server to get the IP address at power up, but a fixed IP address can be configured remotely by using a software capable of sending Ethernet/IP explicit packets, such as EIP Scan Test Tool, from Pyramid Solutions.

For real time control of the power supply, the Ethernet/IP interface has an input assembly object (class 0x04, instance 0x65) and an output assembly object (class 0x04, instance 0x66), with similar functionality to the Mosbus registers.

#### INPUT

The input (Target to Originator) assembly object has the following read registers:

- Input assembly status word (16bit), not used.
- Status (16bit)
- Fault bits (32bit)
- Voltage monitor (32bit)
- Current monitor (32bit)
- Power/Process monitor (32bit)
- Existing modules (16bit)
- Active modules (16bit)

Total of 24 bytes.

#### OUTPUT

The output (Originator to Target) assembly object has the first 4 write registers:

- Output assembly configuration word (16bit), includes the Run/Idle bit.
- Command (16bit)
- Voltage setpoint (32bit)
- Current setpoint (32bit)
- Power/Process setpoint (32bit)

Total of 16bytes.



For more information about the configuration of the Ethernet/IP interface, please refer to the NET485-EIP-MB user manual at Gridconnect website.

#### 4.5.4 ETHERCAT INTERFACE

EtherCAT (Ethernet for Control Automation Technology) is an open high performance Ethernet-based fieldbus system. The development goal of EtherCAT was to apply Ethernet to automation applications which require short data update times (also called cycle times) with low communication jitter (for synchronization purposes) and low hardware costs.

ASD power supplies have an optional EtherCAT interface that allows accessing most of the read and writing registers. The registers that are available are the following:

These write and read registers are linked to EtherCAT PDOs (Process Data Objects), which allow real time control of the power supply. Available PDOs are shown in Table 4-14

**Table 4-14. Registers Available at the EtherCAT Interface**

Write Registers	Read Registers
Command	Status
Vsetpoint	Fault_Bits
Isetpoint	Vmonitor
Psetpoint	Imonitor
	Pmonitor
	Existing_Modules
	Active_Modules
	Module_Status
	Module_Faults
	Module_Warnings
	Z_Output
	Z_Cable
	Vdrop_Cable
	Energy_Meter

In units with an EtherCAT interface, an auxiliary Modbus-RTU (over RS-485) interface is available at the DB9 port, which supports the full functionality and features are available at the other Modbus interfaces. This auxiliary interface can be used together with EtherCAT for non “real-time control” tasks, such as configuration, register saving, module query and firmware update. If both interfaces are used at the same time, the EtherCAT interface has more priority to write registers.

In case the power supply will be controlled over serial Modbus interface (with EtherCAT interface only for monitoring), the write register “Ethercat\_config” allows to disable the write actions coming from EtherCAT. See Table 4-8.

Table 4-15 shows the command registers that must be set in order to operate the power supply from EtherCAT.

**Table 4-15. Commands Bits Required for EtherCAT Operation**

Bit	Value	Description
ON	1	To enable output.
FLOATING_POINT_ENABLED	1	Because the variable type of the PDOs is set to floating point numbers.
DIGITAL PROGRAMMING MODE	1	To enable digital programming.

EtherCAT Process Data Objects (PDOs) and variables are presented in Table 4-16. The variables in red (accompanied by down arrow) are Write Only. The variables in yellow (accompanied by up arrow) are Read only.

**Table 4-16. EtherCAT PDOs and Variables**

EtherCAT PDO Tree	EtherCat PDO variables	
<ul style="list-style-type: none"> <li>Box 1 (ASD)                             <ul style="list-style-type: none"> <li>Unit Status                                     <ul style="list-style-type: none"> <li>Output Enabled</li> <li>Fault</li> <li>Analog Prog</li> <li>Digital Prog</li> <li>I Mode</li> <li>V Mode</li> </ul> </li> <li>System Faults                                     <ul style="list-style-type: none"> <li>Fault Bits</li> </ul> </li> <li>Monitors                                     <ul style="list-style-type: none"> <li>Voltage</li> <li>Current</li> <li>Power</li> </ul> </li> <li>Module count                                     <ul style="list-style-type: none"> <li>Existing Modules</li> <li>Active Modules</li> </ul> </li> <li>Module status bits                                     <ul style="list-style-type: none"> <li>Active</li> <li>Fault</li> <li>Warning</li> </ul> </li> <li>Advanced Monitors                                     <ul style="list-style-type: none"> <li>OutputImpedance</li> <li>CableImpedance</li> <li>CableVoltage</li> <li>Energy</li> </ul> </li> <li>Control Command                                     <ul style="list-style-type: none"> <li>Output Enable</li> <li>Reset Fault</li> <li>Remote Sense disable</li> <li>Analog 4-20mA mode</li> <li>Impedance Monitor enable</li> <li>Modbus Timeout enable</li> <li>Floating Point mode</li> <li>FDR enable</li> <li>Reset energy meter</li> <li>Analog Vprog disable</li> <li>Analog Iprog disable</li> <li>Analog Pprog disable</li> <li>Digital programming mode</li> <li>Process control mode</li> <li>Analog Saturation disable</li> </ul> </li> <li>Setpoints                                     <ul style="list-style-type: none"> <li>Voltage</li> <li>Current</li> <li>Power</li> </ul> </li> <li>WcState</li> <li>InfoData</li> </ul> </li> </ul>	<ul style="list-style-type: none"> <li>Output Enabled      BOOL</li> <li>Fault                BOOL</li> <li>Analog Prog        BOOL</li> <li>Digital Prog        BOOL</li> <li>I Mode                BOOL</li> <li>V Mode                BOOL</li> <li>Fault Bits            DINT</li> <li>Voltage                REAL</li> <li>Current                REAL</li> <li>Power                 REAL</li> <li>Existing Modules    INT</li> <li>Active Modules      INT</li> <li>Active                DINT</li> <li>Fault                 DINT</li> <li>Warning               DINT</li> <li>OutputImpedance    REAL</li> <li>CableImpedance     REAL</li> <li>CableVoltage        REAL</li> <li>Energy                DINT</li> <li>WcState                BOOL</li> <li>State                 UINT</li> <li>AdsAddr              AMSADDRESS</li> <li>Output Enable        BOOL</li> <li>Reset Fault            BOOL</li> <li>Remote Sense di...    BOOL</li> <li>Analog 4-20mA m...    BOOL</li> <li>Impedance Monit...    BOOL</li> <li>Modbus Timeout ...    BOOL</li> <li>Floating Point mode    BOOL</li> <li>FDR enable            BOOL</li> <li>Reset energy meter    BOOL</li> <li>Analog Vprog dis...    BOOL</li> <li>Analog Iprog disa...    BOOL</li> <li>Analog Pprog dis...    BOOL</li> <li>Digital programmi...    BOOL</li> <li>Process control m...    BOOL</li> <li>Analog Saturatio...    BOOL</li> <li>Voltage                REAL</li> <li>Current                REAL</li> <li>Power                 REAL</li> </ul>	

## 4.5.5 SUPERVISORY FAULT CODES

Table 4-17 presents the supervisory fault codes for the Master controller, and Table 4-18 presents the supervisory fault codes the Modules.

**Table 4-17. Master Supervisory Fault Codes**

Code	Name	Description
0x1	SUPERVISORY_I_BIAS	Internal circuits OCP
0x10	SUPERVISORY_CAN	Issue with internal/external communication bus
0x80	SUPERVISORY_LIN	Issue with internal communication bus
0x100	SUPERVISORY_MODBUS_BUFFER_FULL	The received Modbus packet is too big
0x200	SUPERVISORY_MODBUS_ERROR	Issue with Modbus communication, usually because got to many packets
0x400	SUPERVISORY_SPI_ADC_BUSY	Communication issue with analog interface ADC.
0x800	SUPERVISORY_ADC_CONFIGURATION	Analog interface ADC was not properly configured.
0x1000	SUPERVISORY_MB_MODULE_QUERY_ERROR	Issue with the module query Modbus command.
0x2000	SUPERVISORY_FAULT_WATCHDOG	Microprocessor watchdog.
0x4000	SUPERVISORY_FLASH_WRITE_ERROR	There was an error writing internal Flash memory.
0x8000	SUPERVISORY_COMMAND_ERROR	not used
0x10000	SUPERVISORY_FW_UPDATE_NOT_COMPLETE	The firmware update process was not successfully completed.
0x20000	SUPERVISORY_MASTER_NOT_CALIBRATED	The controller was not calibrated or does not have the calibration coefficients loaded. It will use default values.
0x40000	SUPERVISORY_FLASH_CSM	Problem writing Flash memory because it is locked.
0x80000	SUPERVISORY_REDUNDANT_OUTPUT_ON	One of the redundant output enable circuits may have a failure.
0x100000	SUPERVISORY_INCORRECT_HARDWARE_VERSION	The hardware version configured in the firmware is not correct.
0x200000	SUPERVISORY_SPI_ADC_TIMEOUT	The external ADC for the analog interface has not responded.
0x400000	SUPERVISORY_V_BIAS_5V	The 5V internal supply does not meet the requirements.
0x800000	SUPERVISORY_V_BIAS_24V	The 24V internal supply does not meet the requirements.
0x1000000	SUPERVISORY_SWITCH_READ_PROBLEM	the controller reading of the configuration switches is not reliable
0x2000000	SUPERVISORY_ETHERCAT_FAILED_INIT	Only EtherCAT board
0x4000000	SUPERVISORY_WRONG_MASTER_ID	The master ID that was assigned is not compatible with that firmware or hardware

**Table 4-18. Module Supervisory Fault Codes**

Code	Name	Description
0x1	SUPERVISORY_THERMISTOR1	MOSFETs OTP
0x2	SUPERVISORY_THERMISTOR2	output diodes OTP
0x4	SUPERVISORY_HOTWIRE	internal airflow sensing detected low or too hot airflow
0x8	SUPERVISORY_FAN_SPEED	fan speed is below the minimum limit
0x10	SUPERVISORY_CAN	issue with internal/external communication bus
0x20	SUPERVISORY_TSHUNT	output shunt OTP
0x40	SUPERVISORY_AMBIENT	internal ambient OTP
0x80	SUPERVISORY_TDSP	microprocessor internal OTP
0x100	SUPERVISORY_ISHUNT_PEAK	output current OCP
0x200	SUPERVISORY_NO_MASTER	lost communication with master, didn't get any packet from the master for a certain time
0x400	SUPERVISORY_LOW_VDC	input DC bus UVP, went below the absolute minimum
0x800	SUPERVISORY_COMMAND_ERROR	module could not achieve any of the requested setpoints
0x1000	SUPERVISORY_WRONG_LIN_ID	issue with the internal jumper that sets the module address
0x2000	SUPERVISORY_HW_OTP	redundant hardware OTP (MOSFETs or diodes)
0x4000	SUPERVISORY_LOW_LINE	input DC bus UVP, went to a value below the minimum, faults after a certain time
0x8000	SUPERVISORY_VLINE_PEAK	input voltage high speed peak detection
0x10000	SUPERVISORY_VLINE_HIGH	input voltage high line detection
0x20000	SUPERVISORY_CT_PEAK	power converter primary circuit OCP
0x40000	SUPERVISORY_BIAS_PEAK	internal circuits OCP
0x80000	SUPERVISORY_HW_OCP_PEAK	output current redundant hardware OCP
0x100000	SUPERVISORY_OVP	output OVP
0x200000	SUPERVISORY_LIN	internal communication bus issue
0x400000	SUPERVISORY_DISCOVERY_ERROR	the module was not discovered
0x800000	SUPERVISORY_AC_FAULT_FROM_MASTER	AC input missing phase or low line fault
0x1000000	SUPERVISORY_WRONG_SERIAL_NUMBER	the module serial number of the module does not match the backup one
0x2000000	SUPERVISORY_BIAS_FAULT	local bias UVP
0x4000000	SUPERVISORY_FAULT_WATCHDOG	microprocessor watchdog

## 4.6 MODBUS CONTROL USER INTERFACE

The Sorensen ASD Water Cooled power supply supports Modbus communications through Ethernet or Serial communications depending on the power supply model. Presented here is a description of the control interface, beginning with quick-reference instructions for starting and ending communications with the power supply, then proceeding with a description of the menus and pages of the ASD MODBUS Control Interface.

### 4.6.1 MAKING A CONNECTION

1. At the bottom right in the Control interface window use the Interface dropdown button to select the mode of Modbus communication: Ethernet (default) or Serial.

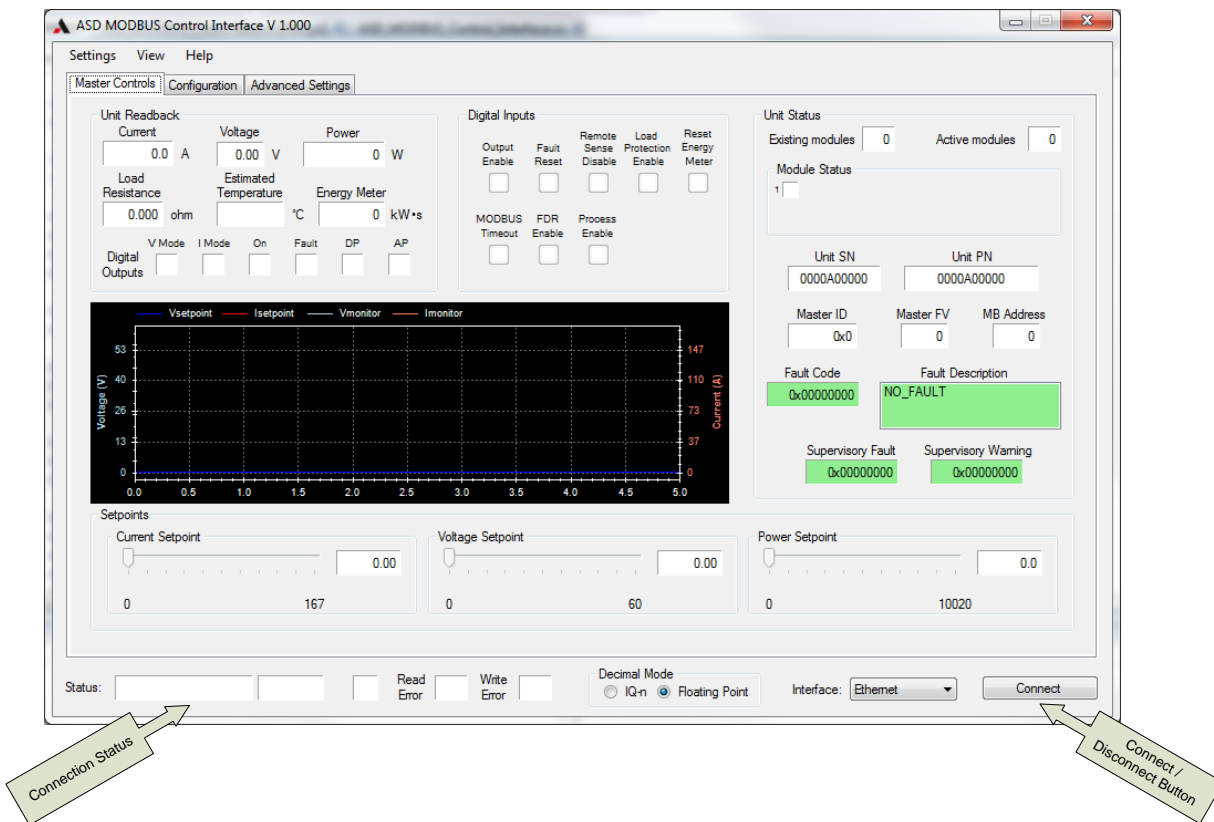

- Click the **Settings** drop-down menu in the upper left of the control interface window, and select the mode of MODBUS communication to be configured, either Ethernet Settings (the Ethernet Settings window appears; go to Step 3) or Serial Settings (the Serial Port Properties window appears; skip to Step 4).

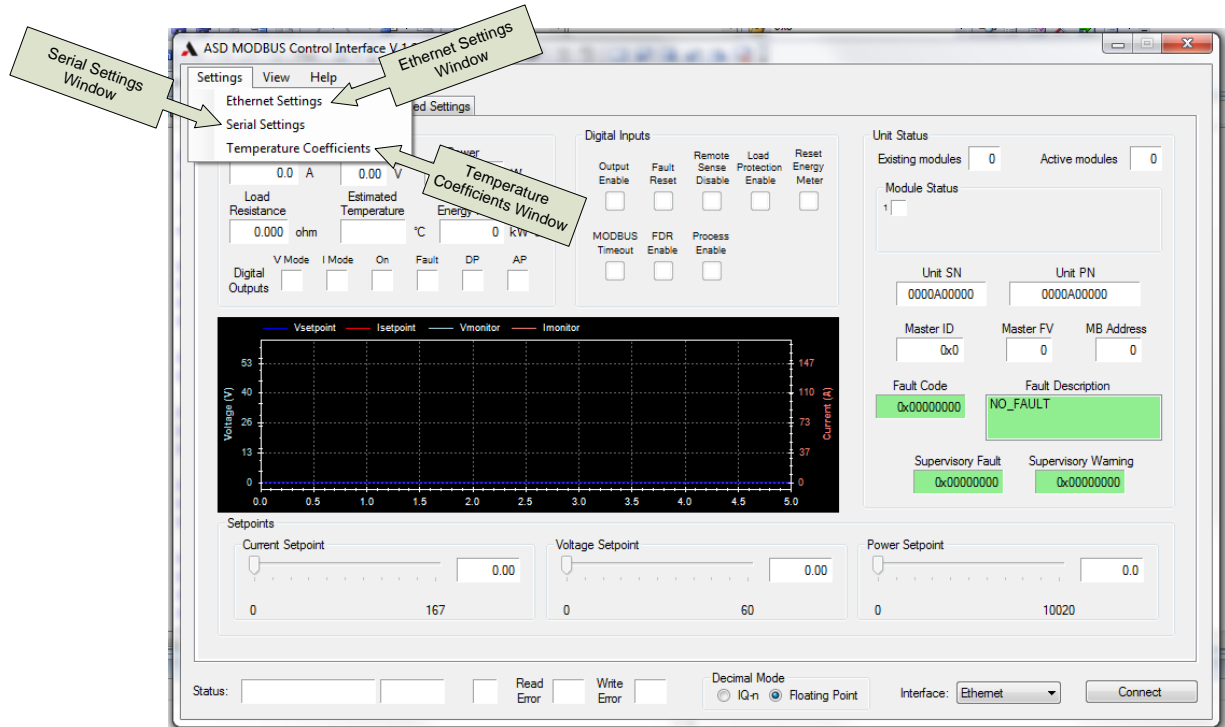

To configure the Ethernet settings:

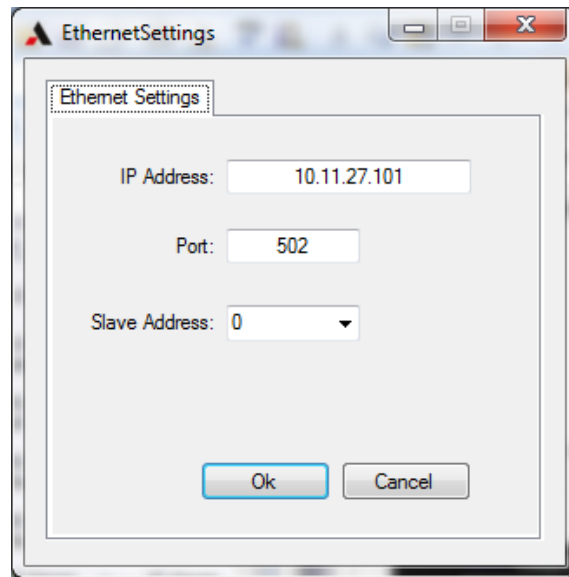

**3. Edit the available fields described as follows:**

- **IP Address:** Input the IP Address of the power supply.
  - **Port:** Should always be set to 502, which is the standard port for Modbus communications.
  - **Slave Address:** Either leave the value at 0 for an automated search by the application to find the slave address used by the power supply, or use the dropdown arrow to set a specific Modbus slave address for communication with the power supply.
- a. Either:
- Click **Ok** to accept the settings and return to the previous window
  - or**
  - Click **Cancel** to return to the previous page without implementing any changes to the settings
- b. Skip to Step 5.



## 4. To configure the Serial Port Properties:

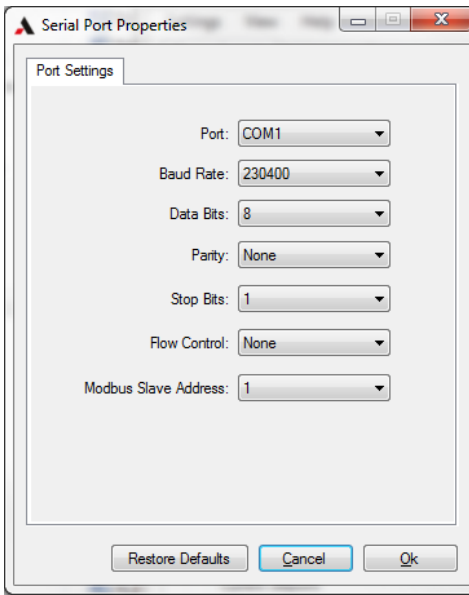

- a. Select the appropriate choices from the drop-down buttons, described as follows:

<b>Port:</b>	Specify the computer COM port to make the serial socket connection.
<b>Baud Rate:</b>	Should always be set to 230400 bits / sec for Modbus serial communications with the power supply.
<b>Data Bits:</b>	Should always be set to 8 bits for Modbus serial communications with the power supply.
<b>Parity:</b>	Should always be set to None for Modbus serial communications with the power supply.
<b>Stop Bits:</b>	Should always be set to 1 for serial communications with the power supply.
<b>Flow Control:</b>	Should always be set to None for serial communications with the power supply.
<b>Modbus Slave Address:</b>	Specify the Modbus slave address used by the power supply.

*Note: Because several power supplies can be connected to one serial Modbus connection the slave address must match that of the power supply.*

- b. Choose to click any of the three buttons at the bottom as follows:
- Click **Restore Defaults** to return the serial port properties to their default settings.
  - Click **Ok** to accept the settings shown and return to the previous window
  - Click **Cancel** to return to the previous page without implementing any changes to the settings.

- c. Continue to Step 5.

**5. Click the Connect button in the bottom right corner of the Master Controls page.**

At this point the program will attempt to make a communications connection using the selected interface (Ethernet or Series).

- If the communications connection is successful, the label on the Connect button will change to **Disconnect** while the program begins cyclic communications with the power supply.
- The **Status** bar at the bottom of the interface window will provide information as described next.

**STATUS BAR**

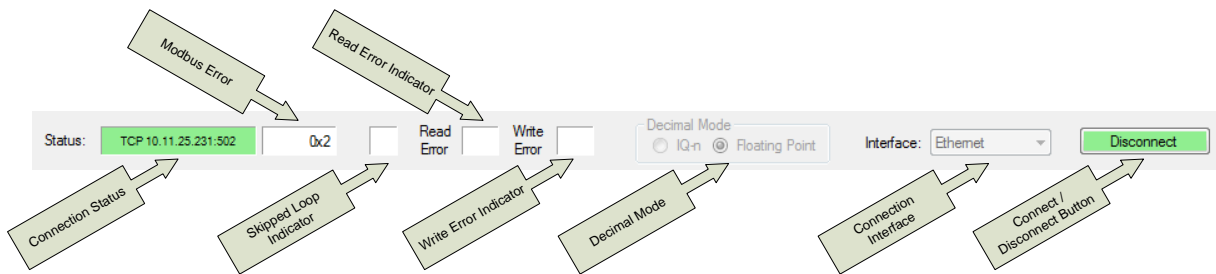

The Status Bar indicates the status of the communications connection to the power supply. It also allows configuration of whether an Ethernet or Serial connection is made to the power supply and the decimal mode used when communicating with the power supply.

<b>Status:</b>	Indicates the type of Modbus connection to the power supply (TCP / RTU) and also the IP address if an Ethernet connection is used or the COM port if a serial connection is used for communications with the power supply
<b>[Modbus Error] field:</b>	Displays the power supply Modbus error register
<b>[Skipped Loop] indicator:</b>	Color changes to red if a communications looped is skipped due to the program being busy.
<b>Read Error:</b>	Color changes to red and displays a hexadecimal error code if a Modbus read error occurs; Reset by clicking in the field.
<b>Write Error:</b>	Color changes to red and displays a hexadecimal error code if a Modbus write error occurs; Reset by clicking in the field.
<b>Decimal Mode:</b>	These radio buttons change the mode which the program uses to send decimal values to the power supply, this setting has little or no effect on the accuracy of setpoint and readback values
<b>Interface:</b>	Drop-down button to select a communication mode connection to the power supply using an Ethernet connection or a serial connection using one of the computer's COM ports
<b>[Connect] / Disconnect:</b>	Click to connect or disconnect from the power supply's digital communications interface.

## 4.6.2 ENDING A CONNECTION

Click the Disconnect button at the bottom right corner of the control interface window. The communications connection will be closed and the Disconnect button label will change to Connect, ready for another connection to be made.

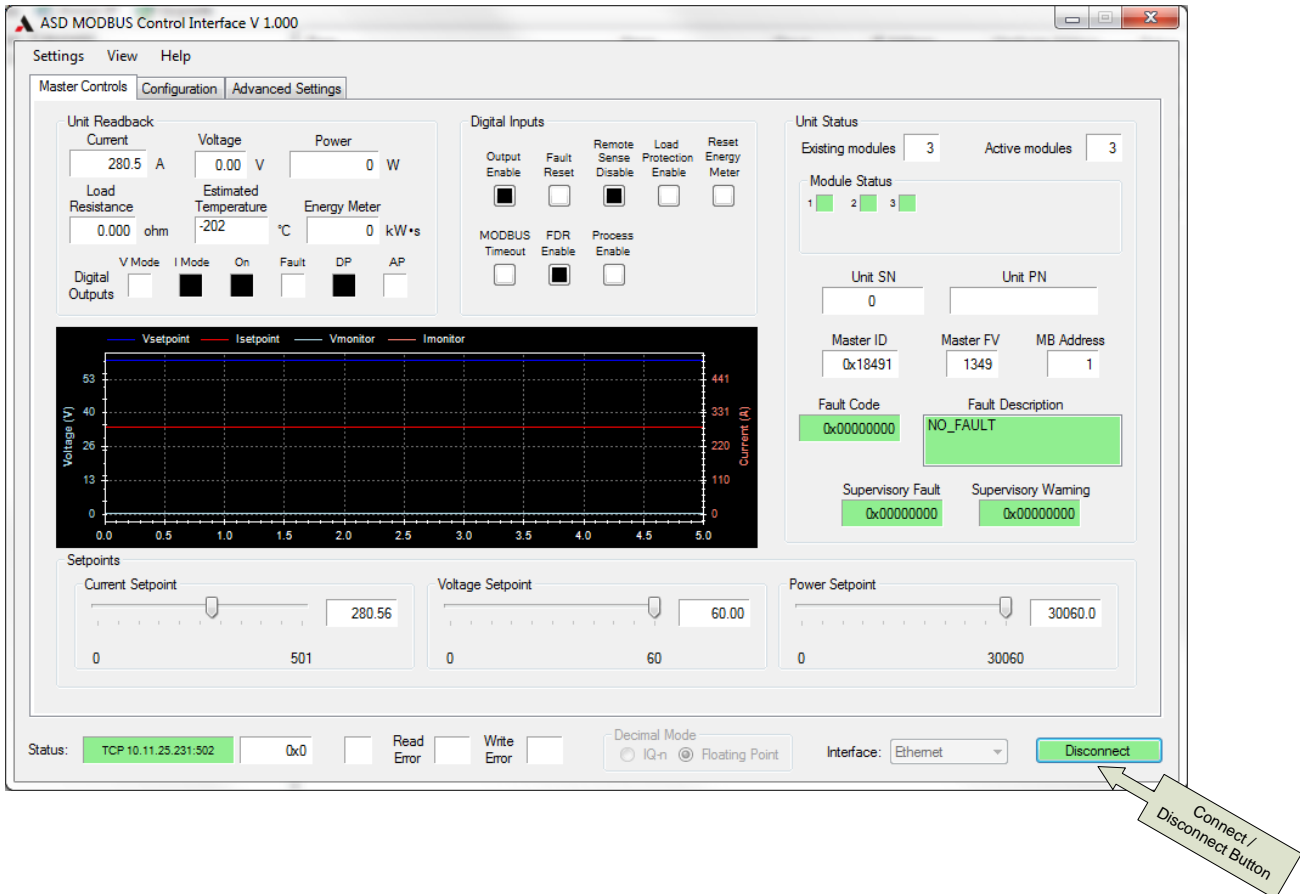

The preceding quick-reference provided instructions for starting and ending communications with the power supply. The remainder of this section describes the menus and pages of the ASD MODBUS Control Interface.

### 4.6.3 SETTINGS MENU

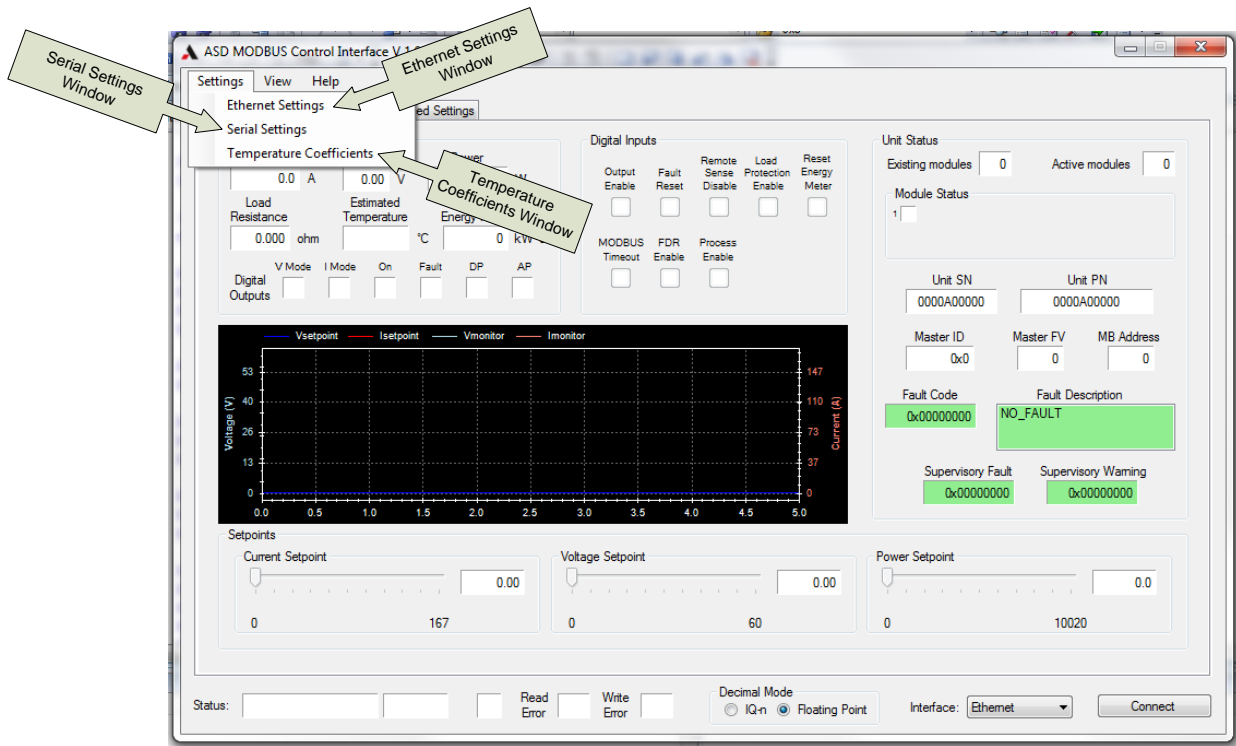

The Settings Menu allows the user to open windows for configuration of communications and temperature coefficient settings used by the program.

**Table 4-19. Settings Menu Selections**

Window	Description
<b>Ethernet Settings</b>	configure the parameters for connecting to a power supply using Modbus over Ethernet communications
<b>Serial Settings</b>	configure the parameters for connecting to a power supply using Modbus over Serial communications
<b>Temperature Coefficients</b>	configure temperature coefficients for estimating temperature based on physical characteristics of the load connected to the power supply

The **Ethernet Settings** window and the **Serial Port Settings** were described in the preceding instructions for Making a Connection.

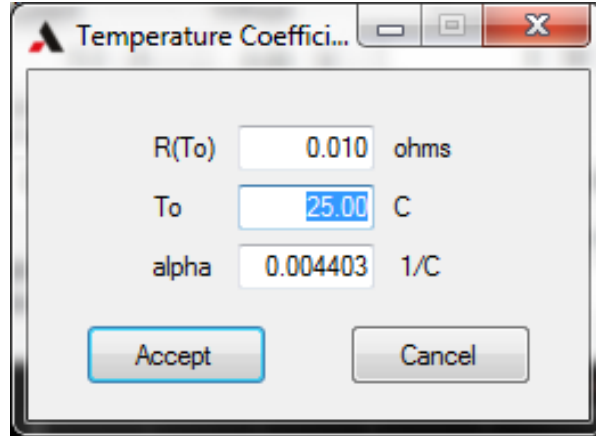
**TEMPERATURE COEFFICIENTS WINDOW**

The Temperature Coefficient window is used for configuring calculated temperature readings based on the output resistance readback of the power supply. The calculated temperature readback is also used for load temperature fault generation. The following equation is used by the program for calculating the estimated temperature:

$$\text{Estimated Temperature} = \frac{\frac{R}{R(T_0)} - 1}{\text{alpha}} + T_0$$

PARAMETER	DESCRIPTION
<b>R(T<sub>0</sub>)</b>	The load resistance at reference temperature T <sub>0</sub>
<b>T<sub>0</sub></b>	The reference temperature
<b>Alpha</b>	The linear temperature coefficient

### 4.6.4 VIEW MENU

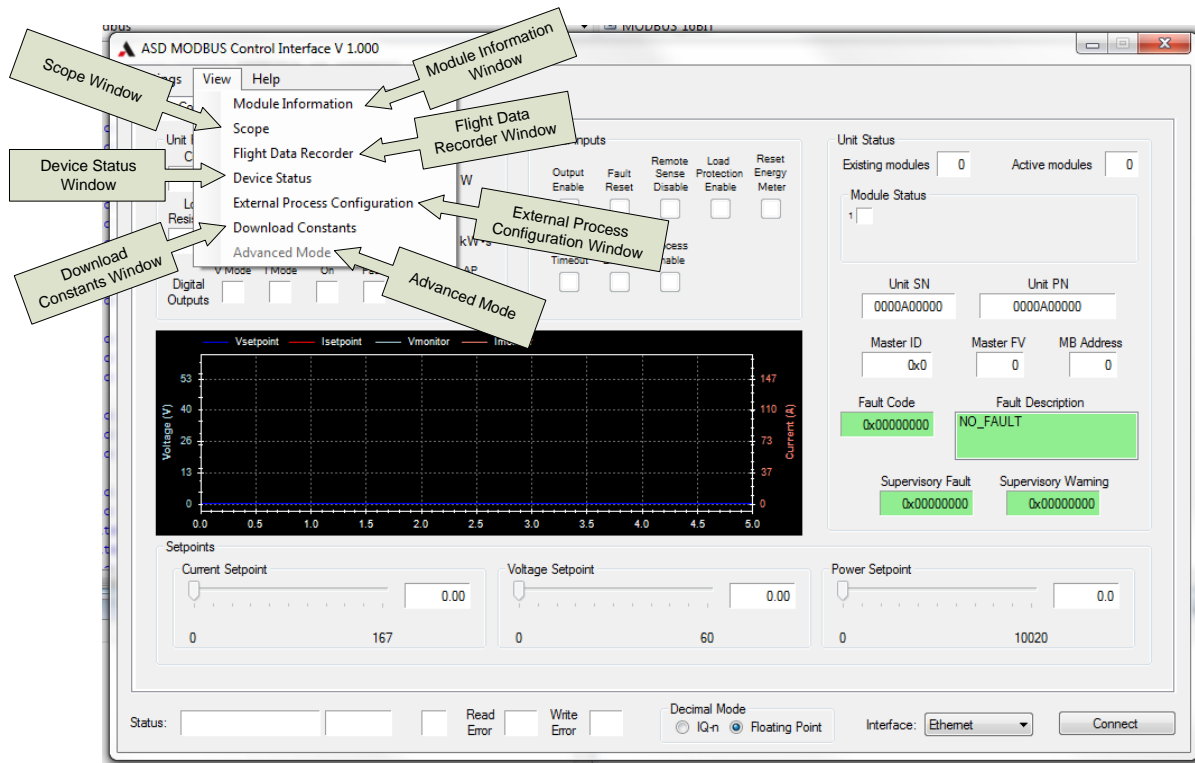

The View Menu leads to other windows to access additional functionality.

WINDOW	DESCRIPTION
<b>Module Information</b>	Reads information from modules discovered by the master.
<b>Scope</b>	Graphically displays signals from the power supply similarly to signals displayed by an oscilloscope.
<b>Flight Data Recorder</b>	Reads data and allows configuration of the master controller and module flight data recorders.
<b>Device Status Window</b>	Reads the status of all devices connected to the power supply master controller including undiscovered modules and disabled master controllers.
<b>External Process Configuration Window</b>	Allows configuration and compensation of logic that allows the power supply to control an external process such as temperature or pressure.
<b>Download Constants Window</b>	Provides interface to download constant values from the master controller and modules to a file that can be sent to AMETEK Programmable Power for technical support.
<b>Advanced Mode</b>	Changes the behavior of some of the sliders and controls on the main form so setpoints can be sent through Modbus even when the power supply is being controlled through the analog interface. <b>Note:</b> <i>this has no effect on the behavior of the power supply.</i>

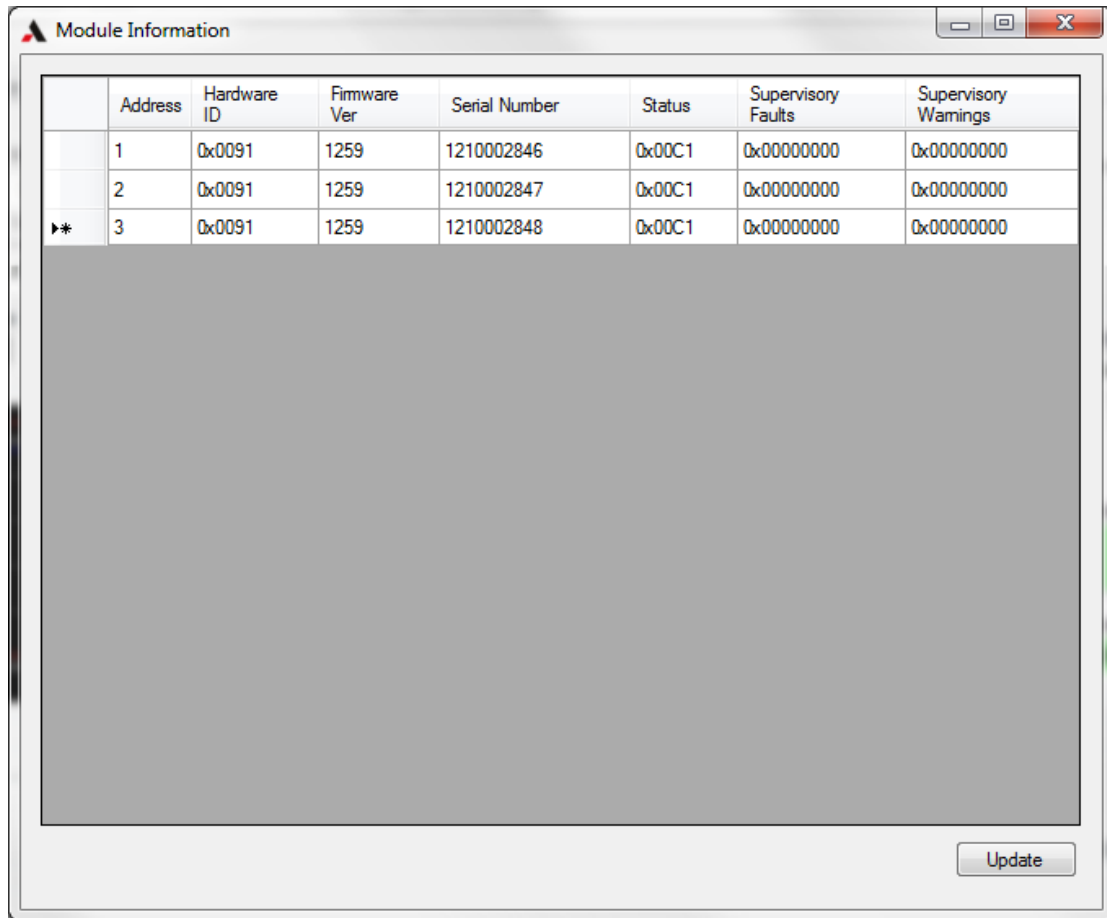
**MODULE INFORMATION WINDOW**

The Module Information window reads information from all of the modules connected to and discovered by the power supply's master controller.

**Note:** if the cursor is held over the *Hardware ID*, *Status*, *Supervisory Faults* and *Supervisory Warnings* fields a tool tip will appear giving descriptions of the bits in that field

**Update** button Stops the program's normal communications with the power supply and the power supply will read information from its discovered modules one field at a time

### SCOPE WINDOW

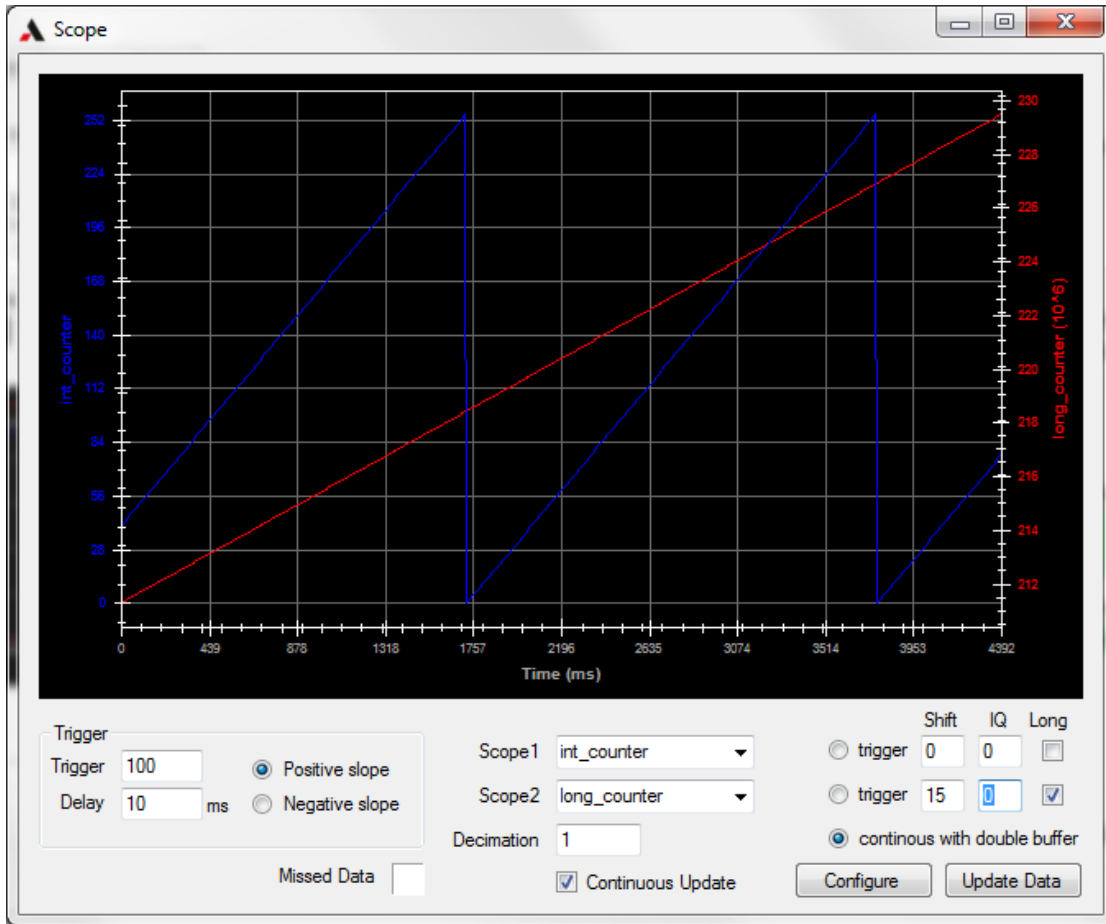

The display in the Scope window emulates an oscilloscope and allows the operator to read some of the power supply internal variables and to display them graphically. All scope values are normalized values and the scaling used by the power supply must be known to get reasonable values. The scope automatically sizes the X and Y axis to fit all of the data in the scope window

**Note:** when the scope is reading data from the power supply the normal read and write communications between the program and power supply are interrupted

**Note:** the scope only reads 16-bits samples, if a 32-bit variable is being read then the Shift configuration must be set so the most significant bits of data are not lost



Parameter	Description
<b>Trigger group</b>	
Trigger	Configures the trigger threshold.
Delay	Sets the delay from the beginning of the sample to the trigger point.
Positive slope	Causes the trigger event to occur on a positive transition through the trigger threshold.
Negative slope	Causes the trigger event to occur on a negative transition through the trigger threshold.
<b>Other controls</b>	
Scope1	Allows the operator to select a predefined signal from the power supply for Channel 1 of the scope and configures the other parameters for this signal.
Scope2	Allows the operator to select a predefined signal from the power supply for Channel 2 of the scope and configures the other parameters for this signal.
Decimation	Configures the sampling rate of the scope. 1 = 125 Hz; 2 = 62.5 Hz; 3 = 61.25...
Missed Data	This box turns red when there is scope data from the power supply that has been missed by the program
Continuous Update	When this control is checked, the scope continues to sample and append data to the scope window until the scope is stopped; when unchecked the scope takes one sample and stops.
trigger and continuous with double buffer	radio buttons to select whether the scope triggers on Channel 1, triggers on Channel 2 or takes continuous samples with no trigger.
Shift	Configures how many bits to shift that channel's data to the right.
IQ	Configures the IQ used by the data on a channel. (converts IQ-formatted decimal numbers to floating point).
Long	Checked indicates that the scope variable is a 32-bit variable. Unchecked indicates that the scope variable is a 16-bit variable.
Configure	Sends the current settings to the power supply so it can configure its internal scope.
Update Data [Stop Update]	Begins reading scope data from the power supply or to stop reading data from the power supply in Continuous Update mode

### FLIGHT DATA RECORDER WINDOW

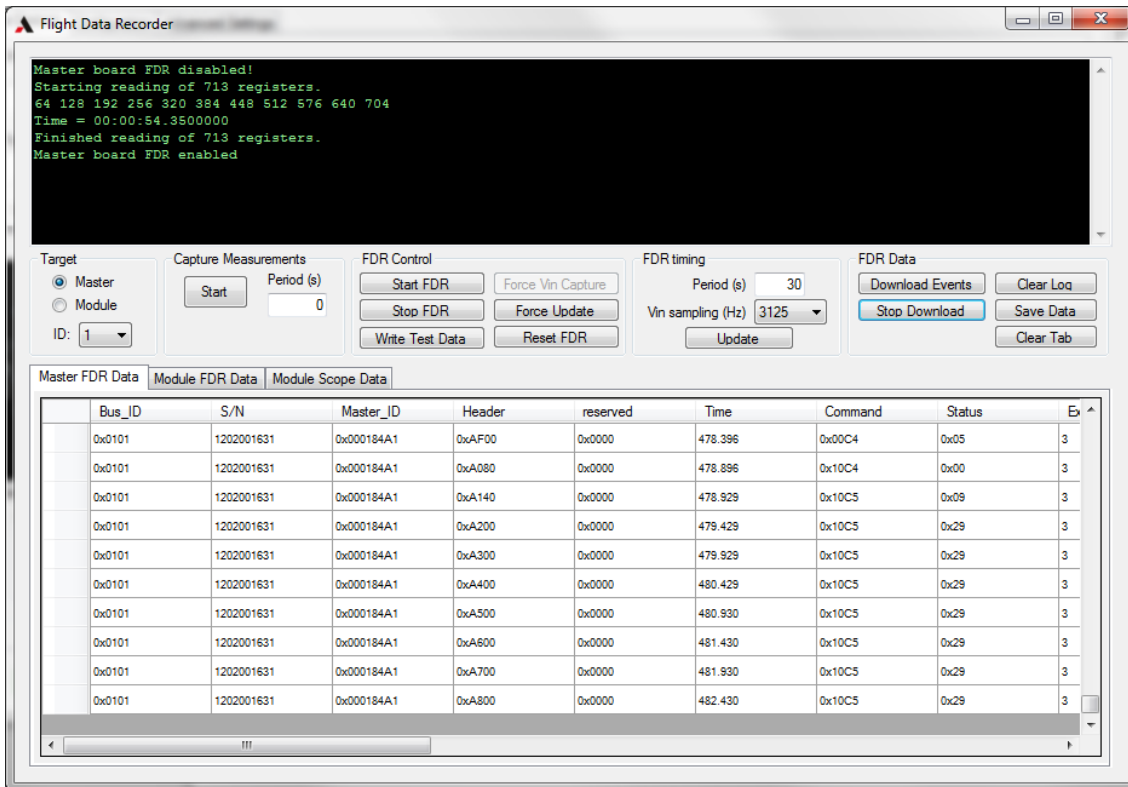

The Flight Data Recorder (FDR) in the power supply’s master controllers and modules takes periodic status snapshots of these devices and also records information when master faults occur on these devices. The FDR displays these data, and also allows configuration and management of the Flight Data Recorders.

**Note:** when data is being downloaded from the FDR this program’s normal communications are interrupted

**Note:** downloading FDR data with the power supply output enabled is not recommended

Parameter	Description
Display window	Log that displays the progress of FDR downloads, the success of configuring and sending commands to the FDR, and any communication error.
<b>Target group</b>	
Master / Module	Radio buttons to set whether the selected device is a module or master flight data recorder
ID	Drop-down menu to select the id of the device made available per the Master or Module radio button.
Start	Begins capture of the current measurements of all module and master devices.
Period (s)	Sets the interval (in seconds) between measurement captures. If zero (0) then only one capture will be taken.

Parameter	Description
<b>FDR Control buttons</b>	
Start FDR	Starts the selected FDR so it periodically captures FDR data while the power supply output is enabled.
Stop FDR	Stops the selected FDR so it does not periodically capture FDR data.
Write Test Data	Writes a test data entry to the selected FDR.
Force Vin Capture	Causes the selected module FDR to capture input voltage waveforms. Note: this control is disabled when Master FDR radio button is selected.
Force Update	Causes the selected FDR to make a data entry of its current state.
Reset FDR	Resets the selected FDR, clearing all FDR entries from the FDR, and starts recording again.
FDR Timing group	Note: FDR timing applies to power supply master controllers, if a module is selected these controls will be disabled.
Period (s)	Configures the interval (in seconds) between periodic FDR updates when the output of the power supply is enabled.
Vin sampling (Hz)	Configures the sampling rate of module FDR input voltage scope captures.
Update	Updates the timings of the power supply master control (applies the interval input in the Period(s) field and the sampling rate selected in the Vin sampling menu).
<b>FDR Data buttons</b>	
Download Events	Starts downloading FDR data from the selected FDR to the tabbed pages in the lower half of this window, i.e., Master FDR Data, Module FDR Data, Module Scope Data.
Stop Download	Stops a download that is in progress.
Clear Log	Clears all text from the log display at the top of the FDR window
Save Data	Saves the FDR data to .csv files for analysis in Excel. Note: the data from each tabbed page will be saved in a separate file, three dialog boxes will allow the user to select where this data is saved and to name the files.
Clear Tab	Deletes all of the data from the tabbed page that's active
<b>Tabbed pages</b>	
Master FDR Data	Populated with the FDR data downloaded from master controllers.
Module FDR Data	Populated with the FDR data downloaded from module controllers.
Module Scope Data	Populated with the FDR scope data downloaded from module controllers.

### CONNECTED DEVICE STATUS WINDOW

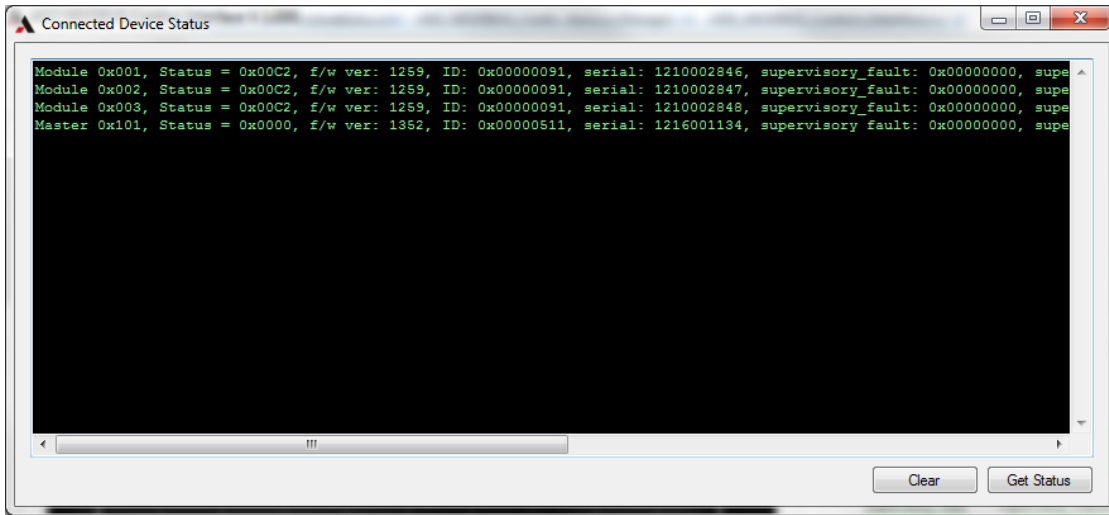

The Connected Device Status window shows information about all of the devices connected to the internal communications interface of the power supply. These devices can include disabled master controllers and modules that have not been discovered by the active master controller.

Clear	Clears the current display in this window.
Get Status	click this button to begin polling for information from all of the devices connected to the internal communications interface of the power supply; the updated information is displayed.

### PROCESS CONTROL WINDOW

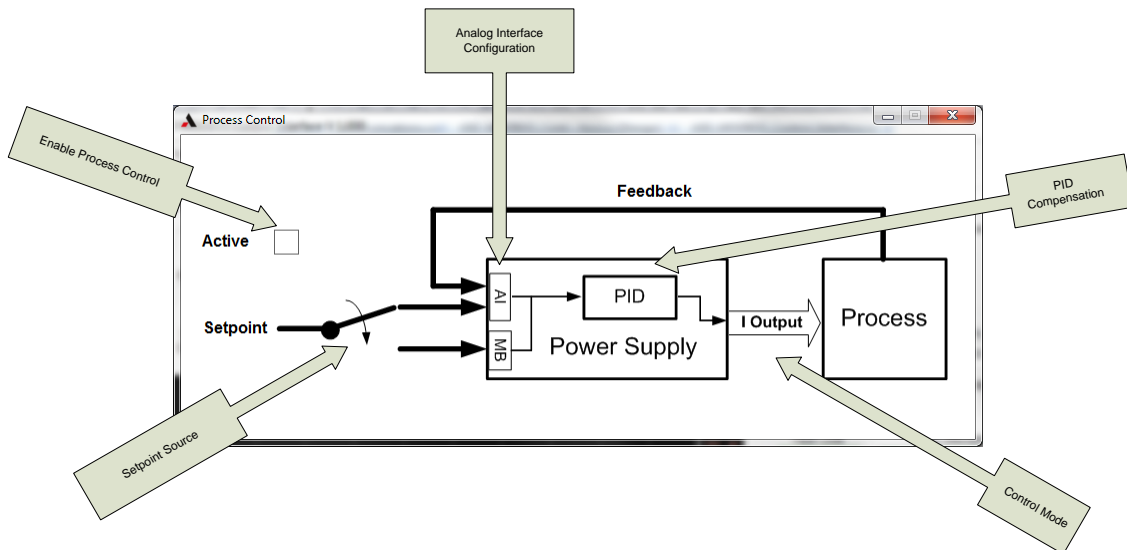

Activating the Process Control enables the power supply to control an external process such as temperature or pressure based on transducer measurements. It also allows configuration of the signals controlling the

process, whether the process is controlled by current or voltage setpoints and the compensation of the process PID control loop

Parameter	Description
Active	Click this control to enable the power supply to operate in Process Control Mode.
Setpoint	Click this switch to toggle the process setpoint source between Modbus (MB) digital communications and the analog interface (AI).
I Output [V Output]	Click this arrow to toggle the process control mode between current control (I Output) and voltage control (V Output).
PID	(Proportional Integral Derivative) Click this box to open the Process Compensation window and adjust the PID parameters for the process control loop
AI	Click this box to open the ProcessAIConfig window for configuring the analog interface setpoint functionality

#### Process Compensation Window

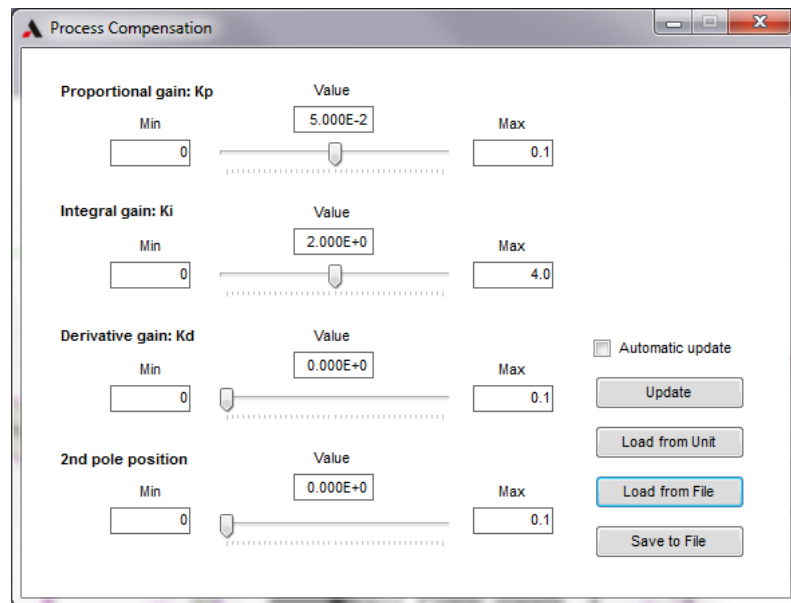

The Process Compensation window allows the user to change the process PID loop compensation gains in order to adjust the power supply's response to changes in the process feedback. Each parameter has a slider for adjusting its respective value. Changing the value in the Min or Max box of a parameter will rescale the range of the slider. The Value field shows the current value of a parameter.

Enter/adjust the Proportional gain in Kp, the Integral gain in Ki, the Derivative gain in Kd, and the 2nd pole position.

<b>Parameter</b>	<b>Description</b>
Proportional gain: Kp	Enter/adjust the value for proportional gain.
Integral gain: Ki	Enter/adjust the value for integral gain.
Derivative gain: Kd	Enter/adjust the value for derivative gain.
2nd pole position	Enter/adjust the value for 2nd pole position.
Min/Max fields	Values input into these fields rescale the range of the slider.
Value fields	Shows the respective parameter's current value.
sliders	Click and drag left or right to adjust the value of the respective parameter.
Automatic Update box	When checked new process PID loop parameters will be sent to the power supply when any parameter's value in this Process Compensation window changes; when unchecked the process parameters must be manually sent to the power supply via the buttons below.
<b>Buttons</b>	
Update	Clicking this button will send the current process compensation parameters to the power supply.
Load from Unit	Clicking this button will update the process compensation parameters in this window with values read from the power supply.
Load from File	Clicking this button will update the process compensation parameters in this window with values read from a file on the computer.
Save to File	Clicking this button will save the current process compensation parameter in this window to a file, a window will open allowing the user to name and select where this file is saved.

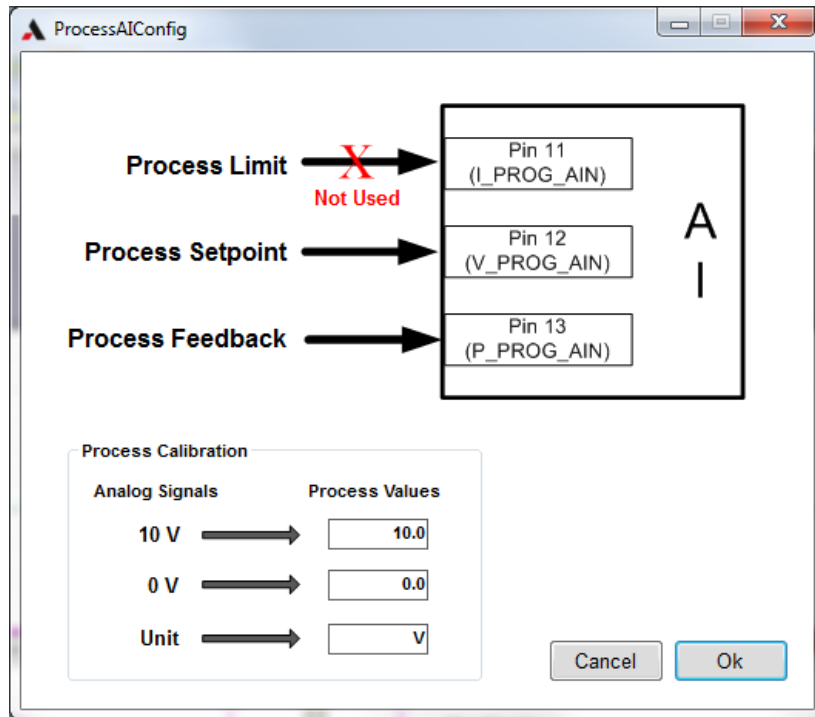
**PROCESSAICONFIG WINDOW**

The ProcessAIConfig window allows the user to change the functionality of the analog interface setpoints depending on the requirements of their process. It also allows the user to define the units and scaling of their process feedback signal for more intuitive monitoring of the process.

Process Limit arrow	Click this arrow to toggle whether pin 11 of the analog interface will be used to program a limit for the maximum current / voltage that the power supply can output during the process.
Process Setpoint arrow	Click on this arrow to toggle whether pin 12 of the analog interface will be used for the process setpoint or the digital communications Psetpoint register will be used.
Process Calibration group	Calibrates the analog process feedback signal range to real values of the process parameter being measured by the transducer.
Cancel	Cancels all changes without accepting them and closes the window.
Ok	Accepts the changes and closes the window.

### DOWNLOAD CONSTANTS WINDOW

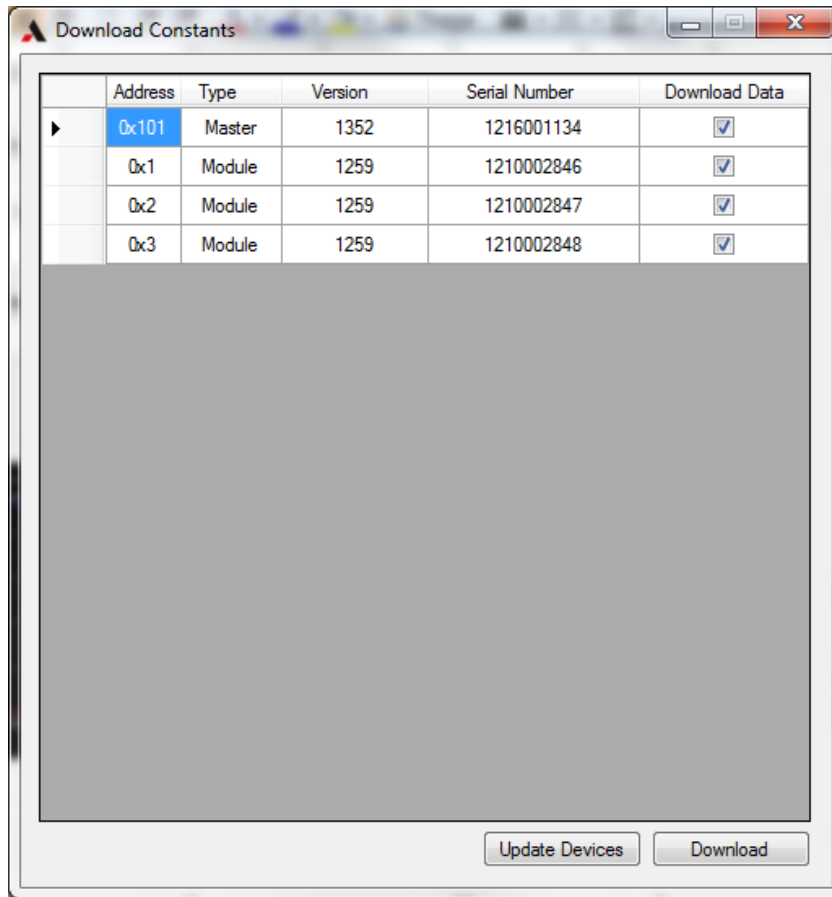

The Download Constants window allows the user to save the constant values from the master and module controllers connected to the internal communications interface of the power supply to a file. After the window scans for devices, the Address, Type, Version and Serial Number of all discovered devices will be shown in this window. The Download Data check boxes allow the user to select which devices will be saved to the data file.

**Note:** *the resulting file contains raw data from the master and module devices and its purpose is for sending to AMETEK Programmable Power to help with technical support of the power supply.*

Update Devices	Click this button to rescan the power supply for devices and to update the window.
Download	Click this button to save the calibration data for the selected devices, a window will open for the user to name the file and choose where the file will be saved.



## 4.6.5 MASTER CONTROLS PAGE

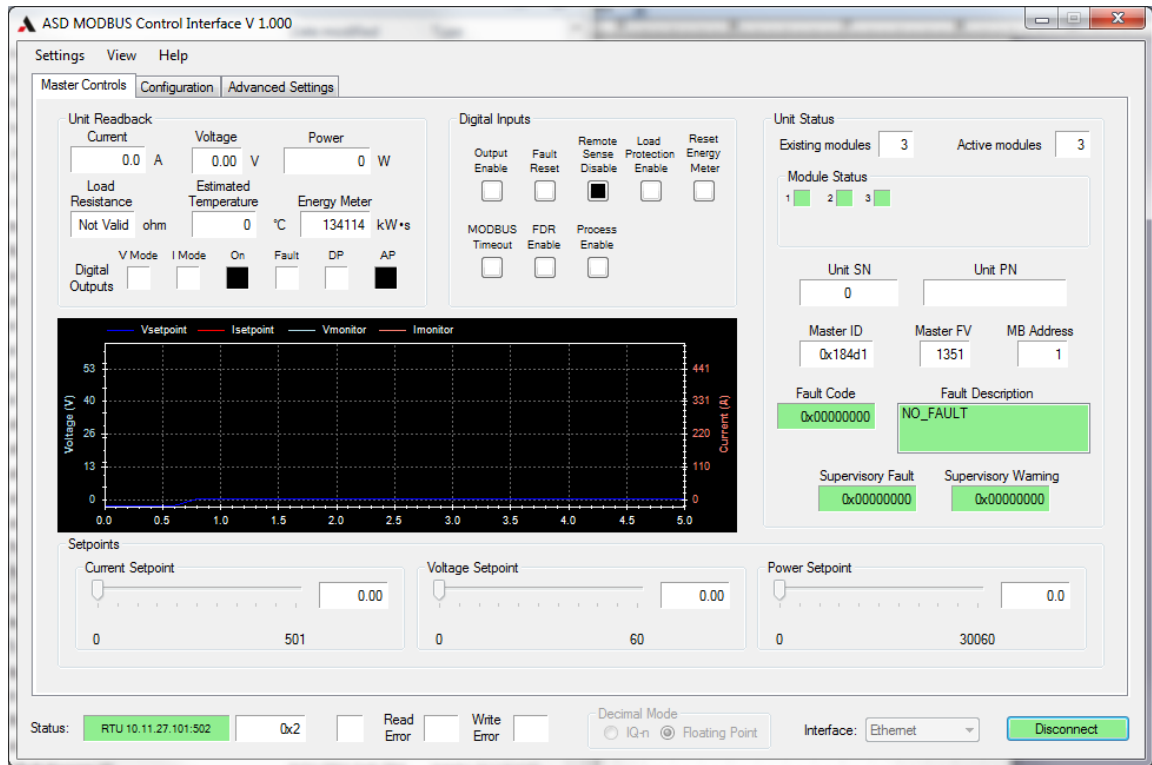

Unit Readback group	
Current	Indicates the current readback of the power supply output in amps
Voltage	Indicates the voltage readback of the power supply output in volts
Power / Process	Indicates the power or process readback of the power supply output in watts or process units (configured in the ProcessAIconfig window).
Load Resistance	Indicates the resistance of the load connected to the power supply output in ohms
Estimated Temperature	Indicates the temperature of the load connected to the power supply in °C, this value is calculated by the program using the temperature coefficients assigned in the Temperature Coefficients window
Energy Meter	Accumulates the total energy output by the power supply since the last time the energy meter was reset in kW*s
Digital Outputs group	Note: a black control indicates true and a white control indicates false.
VMode	If control is black and IMode control is white, the power supply output is in voltage control mode.
IMode	If control is black and Vmode control is white, the power supply output is in current control mode.

<b>Note:</b> If both black (true), this indicates that the power supply output is in power control mode. If both white (false), this indicates that the power supply output is in an unknown mode most likely caused by a setpoint of zero (see Setpoints group) or the output being disabled.	
On	Indicates that the power supply output is enabled.
Fault	Indicates that that a system fault has occurred.
DP	Indicates that the power supply setpoints are being taken from the digital programming interface.
AP	Indicates that the power supply setpoints are being taken from the analog programming interface
Digital Inputs group	Note: clicking the controls in the Digital Inputs group will toggle them between black = true; white = false.
Output Enable	Enables the output of the power supply for programming through the digital programming interface
Fault Reset	Resets any resettable system, master or module fault conditions
Remote Sense Disable	Disables remote voltage sensing so the power supply regulates it's output voltage using a local voltage measurement
Load Protection Enable	Activates the power supply load protection monitoring which is configurable in the main window Advanced tab
Reset Energy Meter	Resets the energy meter to zero so it can begin accumulating the total power output by the power supply
MODBUS Timeout	Enables Modbus timeout monitoring which create a fault if there is no Modbus activity for a interval defined on the main window Advanced Settings tab
FDR Enable	Enables the FDRs (Flight Data Recorders) in the power supply to periodically save information about the power supply status.
Process Enable	Enables the process control feature which allows the power supply to control an external process.
Unit Status group	
Existing modules	Indicates the number of modules existing to the power supply master controller.
Active modules	Indicates the number of modules that are actively outputting or prepared to output power based on master controller commands.
Module Status	A color-coded, numbered box appears in this row for each existing module (maximum 16 modules); red = fault; yellow = warning; green = operating normally
Unit SN	Displays the serial number of the power supply
Unit PN	Displays the part number of the power supply
Master ID	Displays the master id bits of the power supply; if the cursor is held over this control a tool tip will be shown which decodes and gives descriptions of the master id bits
Master FV	Displays the firmware version of the power supply's master controller.

MB Address	MODBUS address of the power supply's master controller.
Fault Code	Displays the system fault bits of the power supply
Fault Description	Displays descriptions of the system fault of the power supply
Supervisory Fault	Displays the supervisory fault bits of the power supply's master controller; if the cursor is held over this control a tool tip will be shown which gives descriptions of the supervisory fault bits
Supervisory Warning: indicates the supervisory warning bits of the power supply's master controller; if the cursor is held over this control a tool tip will be shown which gives descriptions of the supervisory warning bits	
Setpoints group	allows control and monitoring of the power supply's current, voltage and power / process setpoints. Digital: If the power supply's output is turned on by this program through digital programming these sliders will change the setpoints of the power supply. Analog: If the power supply is turned on through the analog interface then these sliders will monitor the analog setpoints signals being read by the analog interface of the power supply.

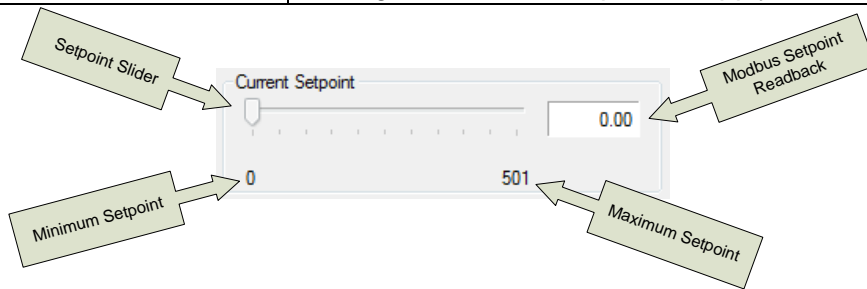

<b>Setpoint Control Elements:</b>	
Setpoint Slider	In digital programming the slider controls the setpoints changes that are sent to the power supply. In analog programming the slider mirrors the changes to the power supply setpoints that are received by the power supply analog interface.
Slider in leftmost position	Setpoint is set to the minimum, which will be sent to the power supply.
Slider in rightmost position	Setpoint is set to the maximum, which will be sent to the power supply.
Field to right of slider	Displays the MODBUS setpoint readback from the power supply.

### POWER SUPPLY MONITOR



The Power Supply Monitor window gives a graphical display of the power supply’s current and voltage setpoint and monitor signals. The color key for the different signals is located at the top of the window. The various components of the power supply monitor are described as follows:

Component	Description
Blue lines:	Voltage setpoint and monitor are displayed in different shades of blue.
Red lines:	Current setpoint and monitor are displayed in different shades of red.
Horizontal axis	Represents time.
Scaling	Shown along the bottom of the window.
Voltage (V):	Vertical axis scaling for the voltage signals is shown at the left side of the window.
Current (A):	Vertical axis scaling for the current signals is shown at the right side of the window.
Tool tips:	If the cursor is held over signals in this window a tool tip will appear showing the name of the signal and the x and y values of the signal at that point.
<b>Note:</b> The timescale and update behavior of the window can be configured at the “Monitor Window” group in the Advanced Settings page.	

### 4.6.6 CONFIGURATION PAGE

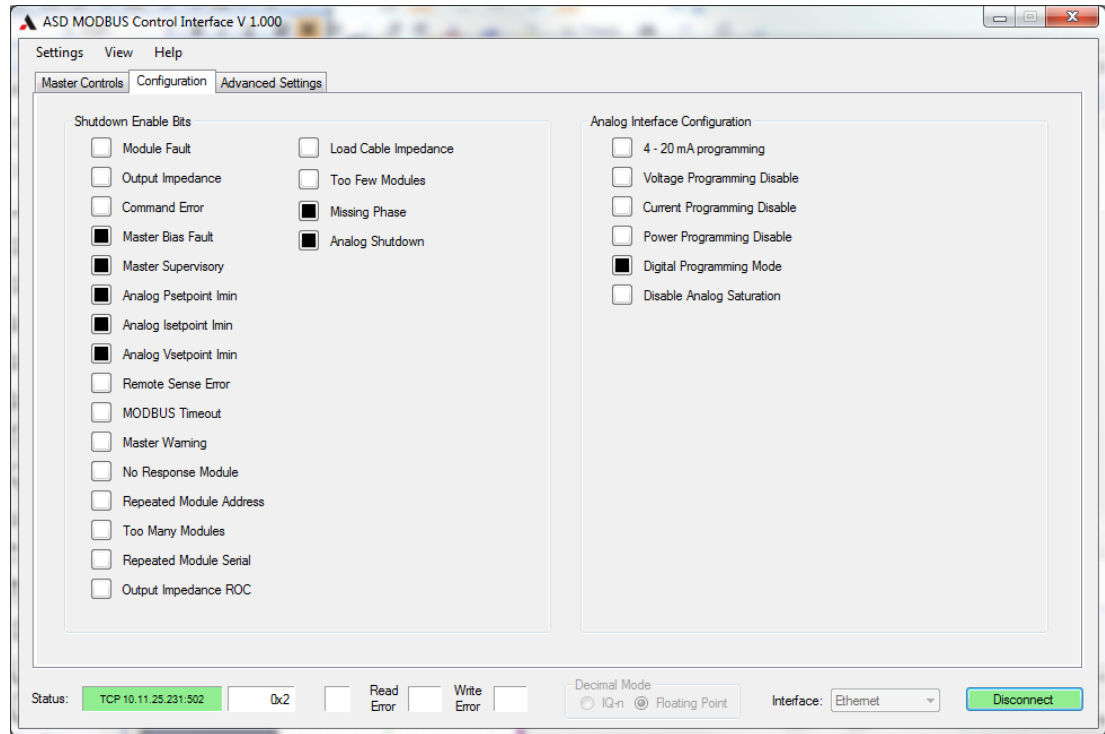

The Configuration page is used to control whether system faults disable the output of the power supply when they occur, it also is used to configure the operation of the analog programming interface.

<p>Shutdown Enable Bits group</p>	<p>Each control in the Shutdown Enable Bits Group sets that system fault to disable the output of the power supply or to allow the output of the power supply to continue. Black = disable the power supply output if that fault occurs. White = continue the power supply output even if that fault occurs.</p>
<p><b>Note:</b> some of the faults are not configurable and always disable the output of the power supply</p>	
<p>Analog Interface Configuration group</p>	<p>Note: clicking the controls in the Analog Interface Configuration group toggles their setting: black = true; white = false</p>
<p>4-20mA Programming</p>	<p>Black/True sets the analog interface inputs and outputs to control and monitor the power supply using current signals. White/false then the analog interface inputs and outputs control and monitor the power supply using 0-10V voltage signals.</p>
<p>Voltage Programming Disable</p>	<p>Disables the analog voltage programming signal and sets the voltage setpoint to either the full-scale voltage or the digital voltage setpoint - depending on the Disable Analog Saturate setting (below),.</p>

Current Programming Disable	Disables the analog current programming signal and sets the current setpoint to either the full-scale current or the digital current setpoint - depending on the Disable Analog Saturate setting (below).
Power Programming Disable	Disables the analog power programming signal and sets the power setpoint to either the full-scale power or the digital power setpoint - depending on Disable Analog Saturate setting (below).
Digital Programming Mode	Black/True sets the power supply into digital programming mode so the power supply must be turned on and off through digital programming and uses the digital setpoints for current, voltage and power. White/false the power supply is in analog programming mode and the power supply must be turned on and off through the analog interface and uses the analog setpoints for current, voltage and power
Disable Analog Saturation	if any of the analog programming signals are disabled, their setpoint will be taken from the digital programming setpoint; if this button is false, then any disabled analog programming signal's setpoint will be set to the full-scale value

## 4.6.7 ADVANCED SETTINGS PAGE

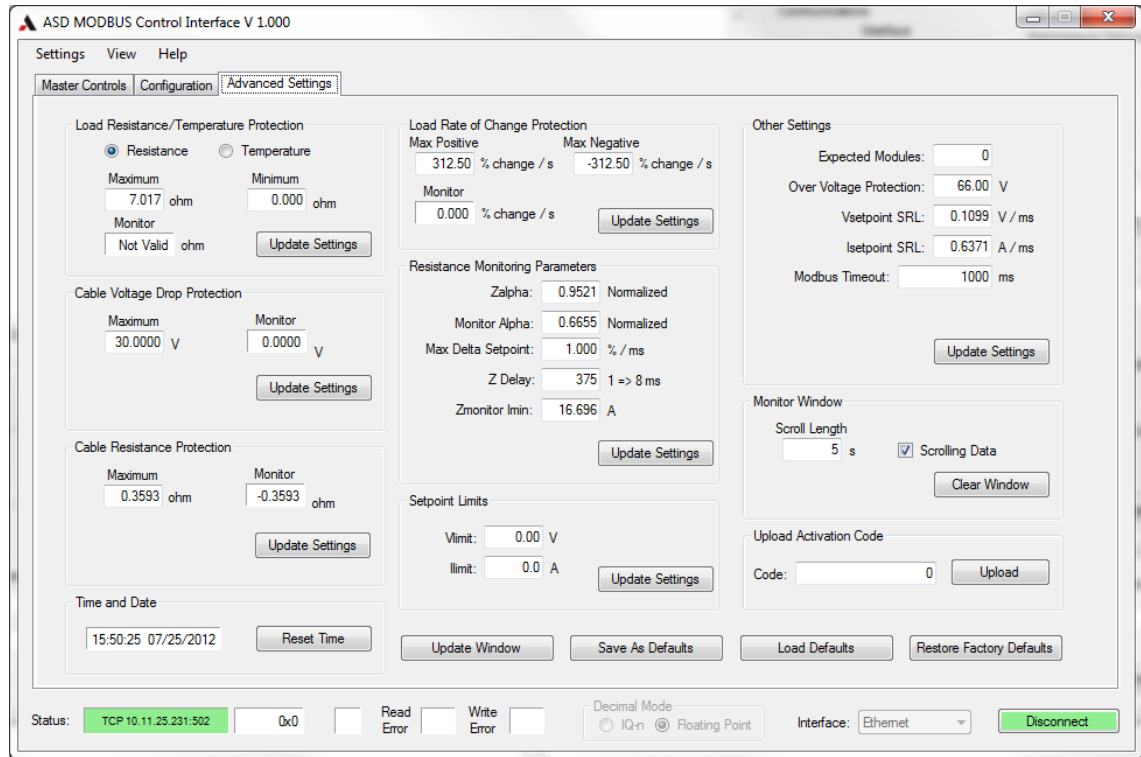

The Advanced Settings page is for configuring the advanced features of the power supply. It is also for configuring the format of the Monitor Window in the Main Controls page, for saving/loading of default digital register values, and for restoring the digital registers to their factory-shipped state.

Page Component	Description/Function
<b>Control buttons in bottom area of page</b>	
Update Window button	Updates the Advanced Settings tab controls with current readings from the power supply.
Save As Defaults button	Saves all of the current settings from all tabs of the main window as the default power-on settings of the power supply.
Load Defaults button	Commands the power supply to reload it's saved default power-on settings.
Restore Factory Defaults button	Commands the power supply to restore all settings to it's factory shipped default settings.
<b>Load Resistance/Temperature Protection group</b>	
Resistance/Temperature radio buttons	Select whether the load resistance/temperature limits are to be calculated from load resistance or from load temperature calculated using the temperature coefficients.

<b>Page Component</b>	<b>Description/Function</b>
Maximum	Maximum resistance or temperature setting used for load resistance protection: if the power supply load measurement goes above this limit a system fault will occur.
Minimum	Minimum resistance or temperature setting used for load resistance protection: if the power supply load measurement goes below this limit a system fault will occur.
Monitor	Displays the power supply readback of the resistance or calculated temperature of the output load
Update Settings	Clicking this button writes the settings for the Minimum and Maximum resistance or temperature limits to the power supply.
<b>Cable Voltage Drop Protection group</b>	
Maximum	Maximum cable voltage drop limit of the power supply while using remote voltage sensing, if the cable voltage drop exceeds this limit a system fault will be generated. (Remote Sense Error in the Configuration page can be set to disable the output of the power supply if this fault occurs).
Monitor	Displays the cable voltage drop readback of the power supply while using remote voltage sensing.
Update Settings button	Click to write the displayed cable voltage drop protection limit to the power supply.
<b>Cable Resistance Protection group</b>	
Maximum	Maximum cable resistance limit of the power supply while using remote sensing; if the resistance across the cables exceeds this limit a system fault will be generated. (Load Cable Impedance in the Configuration page can be set to disable the output of the power supply if this fault occurs).
Monitor	Displays the cable resistance readback of the power supply while using remote voltage sensing.
Update Settings button	Click to write the displayed cable resistance protection limit to the power supply.
<b>Time and Date group (Real Time Clock Option)</b>	
Display	Shows the current time reading of the power supply that includes the Real Time Clock option.



Page Component	Description/Function
Reset Time button	Click this button on a power supply that includes the Real Time Clock option to update the time of the power supply to the current time of the local computer that is controlling it.
<b>Load Rate of Change Protection group</b>	
Max Positive	Maximum positive output load rate of change of the power supply; if impedance protection is enabled and this limit is exceeded, a system fault will be generated by the power supply.
Max Negative	Maximum negative output load rate of change of the power supply, if impedance protection is enabled and this limit is exceeded a system fault will be generated by the power supply.
Monitor	Displays the maximum output load rate of change sensed by the power supply.
<b>Note: if a fault reset is sent this reading will be reset</b>	
Update Settings button	Click to write the displayed Load Rate of Change limits to the power supply
<b>Resistance Monitoring Parameters group</b>	
Zalpha:	Alpha coefficient of the low pass filters used for output resistance measurements.
Monitor Alpha:	Alpha coefficient of the low pass filters used for monitor readbacks.
Max Delta Setpoints:	Maximum change in setpoints for a valid output resistance measurement to be returned.
Z Delay:	Time delay after which the output resistance measurement becomes valid.
Z Monitor Imin:	Minimum current required by the output resistance measurement to return a valid reading.
Update Settings button	Click to write the Resistance Monitoring Parameters to the power supply.
<b>Setpoint Limits group</b>	
Vlimit:	Sets an artificial voltage limit for the power supply and rescales the analog inputs and outputs based on this limit.
Ilimit:	Sets and artificial current limit for the power supply and rescales the analog inputs and outputs based on this limit.
<b>Note: the scaling of the analog power input and output is based on the Vlimit and Ilimit settings (<math>P_{limit} = V_{limit} * I_{limit}</math>); a value of 0 indicates the limit feature is not being used.</b>	
Update Settings button	Click to write the Setpoint Limits to the power supply.

<b>Page Component</b>	<b>Description/Function</b>
<b>Other Settings group</b>	
Expected Modules:	Sets the expected number of modules to be discovered by the master controller.
Over Voltage Protection:	Sets the over-voltage limit of the modules.
Vsetpoint SRL:	Configures the maximum rate at which the voltage setpoint can slew to a new value.
Isetpoint SRL:	Configures the maximum rate at which the current setpoint can slew to a new value.
Modbus Timeout:	When Modbus Timeout is enabled on the Master Controls tab, Modbus Timeout configures the maximum interval between Modbus communications packets before a fault is generated.
Update Settings button	Click to write the Others Settings values to the power supply.
<b>Monitor Window group</b>	
Scroll Length	Adjusts the scale (in seconds) of the Monitor Window horizontal axis in the Master Controls page, when the Scrolling Data parameter is checked.
Scrolling Data	When checked the monitor window data will scroll and the horizontal scaling will be the Scroll Length; when unchecked the monitor window will continue to append new data until the Clear Window button is clicked.
Clear Window button	Click with Scrolling Data checked to clear the Monitor Window and begin appending fresh data.
<b>Upload Activation Code group</b>	
Code	If the digital communications of the power supply are locked (per factory configuration), the unique unlock code for that power supply can be written here to unlock the digital communications and give the full capabilities (both analog and digital interface) of the power supply.
Upload button	Click to upload the activation code displayed in the Code field to the power supply to unlock digital communications.

# SECTION 5 MAINTENANCE

## 5.1 INTRODUCTION

This chapter contains preventive maintenance information for the ASD Series power supplies.

### **WARNING!**



- All maintenance that requires removal of the cover of the unit should only be done by properly trained and qualified personnel.
- Hazardous voltages exist inside the unit.
- Disconnect all power before performing any maintenance.
- Wait at least *five minutes* after power has been removed via external means, before performing service, fuse verification, connection of wiring to the chassis, or connection/disconnection of water coolant tubes (Section Coolant Connections).
- All circuits and/or terminals to be touched must be safety grounded to the chassis.

## 5.2 PREVENTIVE MAINTENANCE

No routine maintenance on the ASD Series is required, aside from periodic cleaning of the unit when needed:

- Once a unit is removed from service, clean the exterior with a mild solution of detergent and water. Apply the solution onto a soft cloth, not directly to the surface of the unit. To prevent damage to materials, do not use aromatic hydrocarbons or chlorinated solvents for cleaning.
- Low-pressure compressed air may be used to remove dust from in and around components on the printed circuit boards.

An annual inspection of the ASD Series unit is recommended. Table 5-1 lists the visual inspection checks to be performed, and the corrective action to be taken.

**Table 5-1. Recommended Annual Inspection**

Item	Inspect For	Corrective Action
External connector plugs and jacks	Looseness, bent or corroded contacts, damage or improper seating in mating connector	Clean contacts with solvent moistened cloth, soft bristle brush, small vacuum, or low compressed air.
		Replace connectors damaged, deeply corroded, or improperly seated in mating connector.
Chassis, fan, and extruded heatsinks	Dirt and corrosion	Clean with cloth moistened with soapy water.
External electrical wiring	Broken, burned or pinched wire; frayed, worn or missing insulation	Repair or replace defective wires.
External solder connections	Corrosion, loose, cracked, or dirty connections	Clean and resolder connections.
Dirt and moisture buildup	Short circuits, arcing, corrosion, overheating	Clean as required.



**CAUTION!**

For safe and continued operation of the ASD Series, always operate the unit in a temperature and humidity controlled, indoor area, free of conductive contaminants.

## 5.3 FUSES

There are no user replaceable components in the power supply.

**WARNING!**

Only properly trained and qualified personnel should remove the cover from the power supply. Service, fuse verification, and connection of wiring to the chassis must be accomplished at least *five minutes* after power has been removed via external means; all circuits and/or terminals to be touched must be safety grounded to the chassis.

**CAUTION!**

To reduce the risk of fire or electrical shock, replace fuses only with the same type and rating.

This page intentionally left blank.

# INDEX

## C

- Circuit Breaker Requirements, 2-28, 2-32
- Controls and Indicators
  - Analog Control (J1), 3-5
- Current Mode
  - Operation, 3-4

## F

- Fuses, 5-3

## I

- Inductive Loads, 2-35
- Input/Output Connections, 2-28
- Isolated Analog Control, 3-5

## J

- J1 Connector, 3-5

## L

- Loads
  - Inductive, 2-35
- Location and Mounting, 2-26

## M

- Maintenance
  - Annual Inspection, 5-2
  - Fuses, 5-3
  - Preventive, 5-1
- Master/Slave Operation, 3-17
- Mounting Hardware, 2-26

## O

- Operation
  - Current Mode, 3-4
  - Local, 3-2
  - Master/Slave, 3-17
  - Parallel, 3-17
  - Remote Current Programming, 3-6
  - Remote Output On/Off Control, 3-15
  - Remote Sensing, 3-14
  - Remote Voltage Programming, 3-9
  - Series, 3-18
  - Voltage Mode, 3-3
- Ozone Precaution, 2-26

## P

- Parallel Operation, 3-17

## R

- Rack slides, 2-26
- Remote Current Programming, 3-6
- Remote Output On/Off Control, 3-15
- Remote Sensing, 3-14
- Remote Voltage Programming, 3-9

## S

- Series Operation, 3-18
- Setup, 3-2
- Specifications, 1-22
  - Electrical Characteristics, 1-23
  - Environmental Characteristics, 1-22
  - Physical Characteristics, 1-24

**V**

Voltage Mode  
Operation, 3-3

**W**

Wire Size, 2-33