



User Manual

IMU Series



- IMU-MGS
- IMU-MGE
- Power Line CDNs
- Data Line CDNs
- Accessories

The Manufacturer

EMC PARTNER AG
Baselstrasse 160
4242 Laufen
Switzerland

Phone +41 61 775 20 30

Fax +41 61 775 20 59

service@emc-partner.ch

Your Local Representative

Check www.emc-partner.ch to find your local representative

Typographical Conventions



Warnings

Safety notices that must be heeded are indicated with this warning triangle.



Additional Advice

Throughout the user manual very important or helpful advice is indicated with this symbol.

The Small Print



All products from EMC PARTNER, where appropriate, fulfil the requirements for CE certification. A copy of the individual certificates can be viewed and downloaded from www.emc-partner.com section company documents.

Version 5.1

Technical Data 4.14

This document may only be reproduced or distributed as the complete document. Partial reproduction of this document requires full, written approval of EMC PARTNER.

Generated on 22nd July 2020 with opensource software \LaTeX

Subject to change without notice.

Safety Instructions



This warning sign is visible on the tester. Meaning: This equipment should only be operated by trained personnel after carefully reading the user manual.

The system belongs to safety class 1.

The system fulfils the requirements of the safety standards IEC 61010 for laboratory measurement equipment "Safety requirements for electrical measuring, control and laboratory equipment".

Consider always the following safety points

- Dangerous mains voltage or high voltages are present inside the test equipment and ALL devices attached to it.
- The Protective Earth must be connected to Earth on the test equipment.
- Before removing any covers from the test equipment, remove all external connection cables.
- Before changing the mains fuse, remove all external connection cables.
- Fuses should only be replaced with the same type and value.
- People with heart pacemakers must not be in the vicinity of the test equipment when it is in operation.
- Do not switch on or operate the test equipment if an explosion hazard exists.
- The test equipment should be operated in a dry room. If condensation is visible, the affected unit(s) should be dried before operating.
- Never touch the Equipment Under Test (EUT), when the test system is operating.
- Establish a safety barrier around the EUT and if required connect it to the safety circuit in the auxiliary connector on the rear panel. The cables under high voltage must not be touched during testing.
- The EUT should be covered and/or well marked during the tests.
- If protective parts are tested, which are likely to explode during tests, they must be covered with a protective cabinet.
- If the test equipment or any of the system components are damaged or it is possible that damage has occurred, for example during transportation, do not apply any voltage.
- This user manual is an integral part of the test system. EMC PARTNER and its sales partners refuse to accept any responsibility for consequential or direct damage to persons and/or goods due to non-observance of instructions contained herein or due to incorrect use of the test equipment.

Sicherheitshinweise



Gefahr! Dieses Warnsymbol ist am Tester sichtbar angebracht. Es bedeutet: Diese Ausrüstung darf nur durch ausgebildetes Personal bedient werden, nachdem diese die Bedienungsanleitung sorgfältig gelesen hat.

Das Gerät gehört der Schutzklasse I an.

Das Gerät erfüllt die Anforderungen der Sicherheitsnormen IEC 61010 für Messungen in Laboratorien "Sicherheitsanforderungen an elektrische Mess- und Regelgeräte sowie Laborausrüstung".

Beachten Sie stets die folgenden Sicherheitshinweise:

- Gefährliche Netzspannung oder Hochspannung liegt im Inneren der Testausrüstung und an ALLEN daran angeschlossenen Geräten an.
- Der Schutzerdeanschluss der Testausrüstung muss mit der Schutzerde des Netzes verbunden sein.
- Bevor Sie irgendwelche Abdeckungen von der Testausrüstung entfernen, entfernen Sie alle äusseren Anschlusskabel.
- Bevor Sie die Netzsicherung austauschen, entfernen Sie alle äusseren Anschlusskabel.
- Netzsicherung nur mit demselben Typ und Ansprechwert ersetzen.
- Personen mit Herzschrittmacher dürfen sich nicht in der Nähe des Geräts aufhalten, wenn dieses in Betrieb ist.
- Schalten Sie die Testausrüstung nicht ein oder betreiben Sie das Gerät nicht, wenn Explosionsgefahr besteht.
- Die Testausrüstung darf nur in einem trockenen Raum betrieben werden. Wenn Kondensation (Beschlag) sichtbar ist, sind die betroffenen Teile der Ausrüstung zu trocknen.
- Berühren Sie niemals die getestete Ausrüstung (EUT), wenn das Testsystem arbeitet.
- Stellen Sie eine Sicherheitsabtrennung rund um das EUT auf und verbinden Sie diese, wenn verlangt, mit dem Sicherheitskreis im Hilfsanschluss (Auxiliary) an der Rückwand. Die unter Hochspannung stehenden Kabel dürfen während des Tests nicht berührt werden.
- Während des Tests sollte das EUT abgedeckt und / oder gut markiert werden.
- Wenn Schutzelemente leicht explodieren können während Tests, müssen diese mit einem schützenden Deckel abgedeckt werden.
- Legen sie keine Spannung an, wenn die Testeinrichtung oder irgendwelche Systembestandteile beschädigt sind oder möglicherweise ein Schaden eingetreten ist, zum Beispiel beim Transport.
- Diese Bedienungsanleitung ist ein vollständiger Bestandteil des Testsystems. EMC PARTNER und seine Verkaufspartner lehnen jede Verantwortung für direkte wie für Folgeschäden an Personen oder Gütern ab, die aufgrund von Nichtbeachten von hierin enthaltenen Anweisungen oder aufgrund von unrichtigem Gebrauch dieser Testausrüstung entstehen.

Consignes de sécurité



Ce sigle d'avertissement est visible sur le testeur. Signification : Cet équipement ne doit être utilisé que par du personnel formé et après avoir soigneusement lu le mode d'emploi.

Le système appartient à la classe de sécurité 1

Le système répond aux exigences des normes de sécurité CEI 61010 pour les équipements de laboratoire "Exigences de sécurité pour les appareils électriques de mesure, de contrôle et d'équipement de laboratoire".

Considérez toujours les points de sécurité suivants :

- Des tensions secteur dangereuses ou des tensions élevées sont présentes à l'intérieur de l'équipement de test et de TOUS les périphériques.
- La mise à la terre de l'équipement de test doit être effectuée.
- Avant de retirer les couvercles de l'équipement, débranchez tous les câbles de connexion externes.
- Avant de changer le fusible secteur, débranchez tous les câbles de connexion externes.
- Les fusibles ne doivent être remplacés que par le même type et valeur.
- Les personnes portant un stimulateur cardiaque ne doivent pas se tenir à proximité de l'équipement de test lorsqu'il est sous tension d'opération.
- Ne pas allumer ou faire fonctionner l'équipement de test si un risque d'explosion existe.
- L'équipement de test doit être utilisé dans un local sec. Si de la condensation est visible, les appareils affectés doivent être séchés avant utilisation.
- Ne jamais toucher l'équipement sous test (EST), lorsque le système est sous fonction.
- Mettre en place une barrière de sécurité autour de l'EST et, si nécessaire raccorder la au circuit de sécurité du connecteur auxiliaire sur le panneau arrière. Les câbles sous haute tension ne doivent pas être touchés pendant le test.
- L'EST doit être couvert et / ou bien marqué pendant les essais.
- Si des éléments de protection sont susceptibles d'exploser lors de tests, ils doivent être couverts avec un boîtier de protection.
- Si l'équipement de test ou l'un des composants du système ont été endommagés ou il est possible que des dommages ont eu lieu, par exemple pendant le transport, ne pas appliquer de tension.
- Ce manuel fait partie intégrante du système de test. EMC PARTNER et ses partenaires commerciaux refusent d'accepter toute responsabilité pour des dommages indirects ou directs à des personnes et / ou des marchandises dues au non-respect des instructions contenues dans ce document ou en raison d'une mauvaise utilisation de l'équipement de test.

Contents

1	System Overview	13
1.1	IMU-MGS	13
1.2	IMU-MGE	13
1.3	IMU-MGS and IMU-MGE Internal Modules	14
1.4	Power Line CDNs and Accessories	17
1.5	Data Line CDNs and Accessories	22
1.6	Accessories for IEC 61000-4-2: ESD	23
1.7	Accessories for IEC 61000-4-4: EFT/Burst	25
1.8	Accessories for IEC 61000-4-5: Surge, and IEC 61000-4-12: Ringwave	26
1.9	Accessories for IEC 61000-4-8/-9: Magnetic Field	27
1.10	Accessories for IEC 61000-4-11/-34: AC Dips, Interrupts and Variations	29
1.11	Accessories for IEC 61000-4-29: DC Dips, Interrupts and Variations	32
1.12	Accessories for IEC 61000-4-16: Common Mode	33
1.13	Accessories for IEC 61000-4-19: Differential Mode	37
1.14	General Accessories	38
2	Initial Operation	39
2.1	Unpacking and Checking	39
2.2	Installation	39
2.3	Powering the Equipment	39
2.4	Safety Circuit	39
3	Hardware Description	40
3.1	IMU-MGS	40
3.1.1	Front Panel	40
3.1.2	Rear Panel	42
3.2	IMU-MGE	44
3.2.1	Front Panel	44
3.2.2	Rear Panel	47
4	Software User Interface	50
4.1	Home Screen	50
4.2	Options Menu	51
4.2.1	Setups	52
4.2.2	Sequence	53
4.2.3	Reports	54
4.2.4	Update	55
4.2.5	Settings	56
4.2.6	Extensions	57
4.2.7	Power	58
4.2.8	Connectors	59
4.3	Setting up and Running a Test	61
5	EUT Power	64
5.1	Connections	65
5.1.1	Internal Variac EXT-IMU V	65
5.1.2	External Variac VAR-EXT1000	66

5.1.3	Fixed Tapped Transformer SRC16-1P	67
5.1.4	Programmable Power Supply PS3	68
5.2	Software Control	69
6	Testsetups - General	72
7	Tests as per IEC 61000-4-2: ESD	73
7.1	Hardware Description	73
7.2	Immunity Tests	74
7.3	Calibration	75
8	Tests as per IEC 61000-4-4: EFT/Burst	78
8.1	Immunity Tests	78
8.1.1	Power Line Coupling with Internal CDN	78
8.1.2	Coupling with Capacitive Coupling Clamp	79
8.1.3	Differential Mode Testing	79
8.2	Calibration	80
8.2.1	Calibration of the Direct Output	81
8.2.2	Calibration of the CDN Output	81
8.2.3	Calibration of the Capacitive Coupling Clamp	82
9	Tests as per IEC 61000-4-5: Surge	83
9.1	Immunity Tests	83
9.1.1	Power Line Coupling with Internal CDN	83
9.1.2	Coupling on Shielded I/O Lines	84
9.2	Calibration	85
9.2.1	Calibration of the Direct Output	85
9.2.2	Calibration of the CDN Output	86
10	Tests as per IEC 61000-4-12: Ring Wave	88
10.1	Immunity Tests	88
10.1.1	Power Line Coupling with Internal CDN	88
10.2	Calibration	89
10.2.1	Calibration of the Direct Output	89
10.2.2	Calibration of the CDN Output	90
11	Tests as per IEC 61000-4-8: AC Magnetic Fields	92
11.1	Immunity Tests	92
11.2	Calibration	94
12	Tests as per IEC 61000-4-9: Impulse Magnetic Fields	96
12.1	Immunity Tests	96
12.2	Calibration	97
13	Tests as per IEC 61000-4-11: AC Dips, Interrupts and Variations <16 A	98
13.1	Immunity Tests	98
13.1.1	Tests using the Internal Variac	98
13.1.2	Tests using the External Variac	99
13.1.3	Tests using the External Tapped Transformer	100

13.2	Calibration	100
13.2.1	Verification of the Voltage Variation	101
13.2.2	Verification of the Inrush Current and Switching Time	101
14	Tests as per IEC 61000-4-34: AC Dips, Interrupts and Variations >16 A	103
14.1	Hardware Description	103
14.1.1	PFS32	103
14.1.2	PFS75	105
14.1.3	SRC32	106
14.1.4	SRC75	108
14.2	Immunity Tests	109
14.3	Calibration	110
15	Tests as per IEC 61000-4-29: DC Dips, Interrupts and Variations	113
15.1	Immunity Tests	113
15.1.1	DC Variations and Interruptions Testing	113
15.1.2	DC Dips Testing	114
15.2	Calibration	115
15.2.1	Verification of DC Interrupts Inrush Currents and Switching Time	115
15.2.2	Verification of DC Dips Inrush Current and Switching Time	116
16	Tests as per IEC 61000-4-16: Common Mode	118
16.1	Immunity Tests	118
16.1.1	Common Mode DC Testing on 2 Power Lines	118
16.1.2	Common Mode Testing on 3 Power Lines	119
16.1.3	Common Mode Testing on up to 4 Power or Data Lines	120
16.1.4	Common Mode Testing on up to 8 Power or Data Lines	122
16.1.5	Common Mode Testing on 1 Balanced Data Line Pair	123
16.1.6	Common Mode Testing on 2 Balanced Data Line Pairs	124
16.1.7	Common Mode Testing on 4 Balanced Data Line Pairs	125
16.1.8	Common Mode Testing on Shielded Cables	126
16.1.9	Disturbance Testing on 2 Lines as per IEC 60255-22-7/-26	127
16.2	Calibration	128
16.2.1	Calibration of the CDN Output	128
16.2.2	Calibration of the EXT-IMU C-SHORT	130
17	Tests as per IEC 61000-4-19: Differential Mode	132
17.1	Hardware Description	132
17.2	Immunity Tests	134
17.2.1	Current immunity test	134
17.2.2	Voltage immunity test	139
17.3	Calibration	140
17.3.1	Calibration of current test	140
17.3.2	Calibration of voltage test	141
17.3.3	Verification of voltage test CDN	142
18	Tests on Power Lines with External CDNs	143
18.1	Hardware Description	143
18.1.1	CDN-M-x-32	143

18.1.2	CDN-A-x-32	144
18.1.3	CDN-A-63	144
18.1.4	CDN-A-125	145
18.1.5	CDN-A-200	146
18.1.6	CDN-F-125	148
18.2	CDN-A Test Setups	148
18.2.1	CDN-A AC-Test Setup for Surge and Ring Wave	149
18.2.2	CDN-A AC-Test Setup for EFT	150
18.2.3	CDN-A AC-Test Setup with PROTx-AC690	151
18.2.4	CDN-A DC-Test Setup	152
18.2.5	CDN-A DC-Test Setup with PROTx-DCyy	153
18.2.6	CDN-A DC-Test Setup with DC-DCxx Damping Network	154
18.3	CDN-M Test Setups	156
18.3.1	CDN-M AC-Test Setup for Surge and Ringwave	156
18.3.2	CDN-M AC-Test Setup for EFT	158
18.3.3	CDN-M DC-Test Setups	159
18.3.4	CDN-M Test Setups with PROT and DC-DC-xx accessories	159
18.4	CDN-F Test Setups	159
18.5	Calibration	160
18.5.1	Surge and Ring Wave Calibration	160
18.5.2	EFT/Burst Calibration	164
19	Tests on Data Lines with External CDNs	166
19.1	CDN-KIT1000 ED3	166
19.1.1	Test Setup	166
19.1.2	Calibration Setup	167
19.2	CDN-DATA-4L/8L	168
19.2.1	Test Setup	169
19.2.2	Calibration Setup	170
19.3	CDN-UTP ED3	171
19.3.1	Hardware Description	172
19.3.2	Test Setup CDN-UTP ED3 on Unsymmetrical Data Lines	173
19.3.3	Test Setup CDN-UTP ED3 on Symmetrical Data Lines	174
19.3.4	Calibration Setup CDN-UTP ED3 on Unsymmetrical Data Lines	175
19.3.5	Calibration Setup CDN-UTP ED3 on Symmetrical Data Lines	177
19.4	CDN-UTP8 ED3	179
19.4.1	Hardware Description	179
19.4.2	Test Setup CDN-UTP8 ED3 on Unsymmetrical Data Lines	180
19.4.3	Test Setup CDN-UTP8 ED3 on Symmetrical Data Lines	181
19.4.4	Calibration Setup CDN-UTP8 ED3 on Unsymmetrical Data Lines	186
19.4.5	Calibration Setup CDN-UTP8 ED3 on Symmetrical Data Lines	188
20	Remote Operation	190
20.1	TEMA3000	190
21	Maintenance and Service	191
21.1	Firmware update	191
21.2	Maintenance	191
21.3	Cleaning	191

21.4	Warranty	191
21.5	Customer Service	192
21.6	Recycling / Disposal	192
22	Technical Data	193
22.1	IMU-MGS	193
22.1.1	EUT Power Management	193
22.1.2	EFT	193
22.1.3	CWG	194
22.1.4	CWG Magnetic Field	195
22.1.5	AC Magnetic Field	196
22.1.6	AC DIP/Interruption	197
22.1.7	Voltage Variation	198
22.1.8	DC DIP/Interruption	198
22.1.9	Common Mode Disturbance	199
22.1.10	Main System	200
22.2	IMU-MGE	201
22.2.1	EUT Power Management	201
22.2.2	EFT	202
22.2.3	CWG	203
22.2.4	CWG Magnetic Field	204
22.2.5	AC Magnetic Field	205
22.2.6	Ringwave	206
22.2.7	Telecom	207
22.2.8	AC DIP/Interruption	208
22.2.9	Voltage Variation	209
22.2.10	DC DIP/Interruption	209
22.2.11	Common Mode Disturbance	210
22.2.12	Main System	211
22.3	CDN-M-x-32	212
22.3.1	EUT	212
22.3.2	EFT	213
22.3.3	CWG	214
22.3.4	Ringwave	216
22.3.5	General	217
22.4	CDN-A-x-32	217
22.4.1	EUT	217
22.4.2	EFT	218
22.4.3	CWG	218
22.4.4	Ringwave	220
22.4.5	General	221
22.5	CDN-A-x-63	221
22.5.1	EUT	222
22.5.2	EFT	223
22.5.3	CWG	224
22.5.4	Ringwave	226
22.5.5	General	227

22.6	CDN-A-x-125	227
22.6.1	EUT	228
22.6.2	EFT	229
22.6.3	CWG	230
22.6.4	Ringwave	232
22.6.5	General	233
22.7	CDN-A-x-200	233
22.7.1	EUT	234
22.7.2	EFT	235
22.7.3	CWG	236
22.7.4	Ringwave	238
22.7.5	General	239
22.8	CDN-F-125	239
22.8.1	EUT	240
22.8.2	EFT	240
22.8.3	General	241
22.9	PROT32-690AC / PROT63-690AC / PROT125-690AC / PROT200-690AC	241
22.10	PROT32-yyyDC / PROT63-yyyDC / PROT125-yyyDC / PROT200-500DC	242
22.11	DC-DC32 / DC-DC63 / DC-DC125 / DC-DC200	243
22.12	CDN-DATA	244
22.12.1	EUT	244
22.12.2	Surge	244
22.12.3	Ringwave	245
22.12.4	General	245
22.13	CDN-KIT1000 ED3	246
22.13.1	EUT	246
22.13.2	Surge	246
22.13.3	General	247
22.14	CDN-UTP ED3 / CDN-UTP8 ED3	247
22.14.1	CWG on Asymmetric Lines	248
22.14.2	Ringwave on Asymmetric Lines	249
22.14.3	CWG on Symmetric Lines	249
22.14.4	Ringwave on Symmetric Lines	250
22.14.5	Telecom on Symmetric Lines	251
22.14.6	EUT	251
22.14.7	General	252
22.15	ADAPTER BOX RJ45	252
22.16	EXT-IMU E	252
22.17	ESD-TARGET2 / ESD-TARGET2 DN	253
22.18	ESD-VERI-V	254
22.19	ESD-STAND Ed2	254
22.20	ESD-VCP50	254
22.21	EARTH CABLE	255
22.22	EFT INSULATION	255
22.23	CN-EFT1000	255
22.24	VERI-CP-EFT	256
22.25	VERI50 EFT	256
22.26	VERI1K EFT	257

22.27	CN-BALUN-AC	257
22.28	CN-R40C05 / CN-R40C05 8	258
22.29	V-PROBE-SI	258
22.30	I-PROBE-P101	259
22.31	MF1000-1	259
22.32	DIPS100E	260
22.33	VAR-EXT1000	260
22.34	SRC16-1P	261
22.35	VERI-DIPS	261
22.36	SRC32-18UH / SRC32-AMD1	262
22.37	PFS32	263
22.38	SRC75-18UH / SRC75-690	264
22.39	PFS75 / PFS75-690	265
22.40	RESISTOR 50 Ohm	266
22.41	PS3	266
22.42	RS485-RS232 ADAPTER	267
22.43	EXT-IMU C-SHORT	267
22.44	CN16 / CN16-8L	268
22.45	CN16-300	269
22.46	CN16DC	269
22.47	CN16T / CN16T4	270
22.48	CN16T8	271
22.49	CN16-22-7C	271
22.50	CN16-22-7D	272
22.51	DN16-1P6 / DN16-1P16	272
22.52	IMU SLAVE SMART I1V1	273
22.52.1	IMU SLAVE SMART V1	273
22.52.2	IMU SLAVE SMART I1	274
22.52.3	IMU SLAVE SMART Main	275
22.53	VERI10-50	275
22.54	EMERGENCY-STOP	276
22.55	WARNING-LAMP	276

1 System Overview

1.1 IMU-MGS

IMU-MGS is a modular generator for conducted immunity testing up to 5.1kV. The generator offers an integrated single-phase coupling and decoupling network and can be extended according to your test requirements at any time, with any of the following integrated modules:

- EXT-IMU4000 S4 / S5
- EXT-IMU4000 F4 / F5
- EXT-IMU V
- EXT-IMU D
- EXT-IMU C

A 7 inch graphic colour touch panel provides an intuitive and comfortable user interface. Interactive parameter input, help texts, and graphic illustrations guide the user through the instrument programming process.



1.2 IMU-MGE

IMU-MGE is an enhanced version of IMU-MGS, it is a modular generator for conducted immunity testing up to 8 kV. The generator offers an integrated single-phase coupling and decoupling network, and can be extended according to your test requirements at any time, with any of the following integrated modules:

- EXT-IMU3000 S6 / S8
- EXT-IMU3000 F5 / F6 / F7
- EXT-IMU3000 R6 / R8
- EXT-IMU3000 T6 / T8
- EXT-IMU V
- EXT-IMU D
- EXT-IMU C

As for the IMU-MGS, a 7 inch graphic colour touch panel provides an intuitive and comfortable user interface. Interactive parameter input, help texts, and graphic illustrations guide the user through the instrument programming process.



1.3 IMU-MGS and IMU-MGE Internal Modules

1.3.1 EXT-IMU4000 S4 (PN 109077) / S5 (PN 108605)

EXT-IMU4000 S4 is an internal module for the IMU-MGS generator that extends its capabilities to Surge immunity tests with an 1.2/50 us impulse according to IEC 61000-4-5 and ITU-T K44 and voltages up to 4.1 kV.

EXT-IMU4000 S5 is an internal module for the IMU-MGS generator that extends its capabilities to Surge immunity tests with an 1.2/50 us impulse according to IEC 61000-4-5 and ITU-T K44 and voltages up to 5.1 kV.

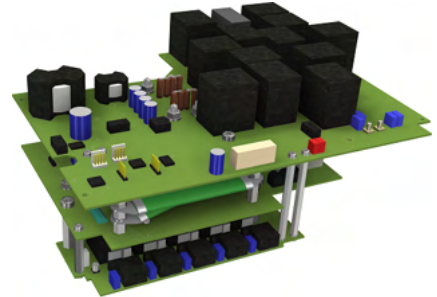

1.3.2 EXT-IMU4000 F4 (PN 106896) / F5 (PN 106898)

EXT-IMU4000 F4 is an internal module for the IMU-MGS generator that extends its capabilities to EFT immunity tests according to IEC 61000-4-4 and voltages up to 4.4 kV.

EXT-IMU4000 F5 is an internal module for the IMU-MGS generator that extends its capabilities to EFT immunity tests according to IEC 61000-4-4 and voltages up to 5.1 kV.

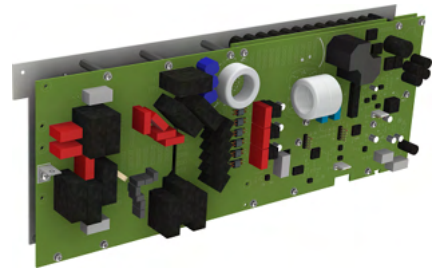

1.3.3 EXT-IMU3000 S6 (PN 106536) / S8 (PN 105679)

EXT-IMU3000 S6 is an internal module for the IMU-MGE generator that extends its capabilities to Surge immunity tests with an 1.2/50 us impulse according to IEC 61000-4-5 and ITU-T K44 and voltages up to 6.6 kV.

EXT-IMU3000 S8 is an internal module for the IMU-MGE generator that extends its capabilities to Surge immunity tests with an 1.2/50 us impulse according to IEC 61000-4-5 and ITU-T K44 and voltages up to 8.0 kV.

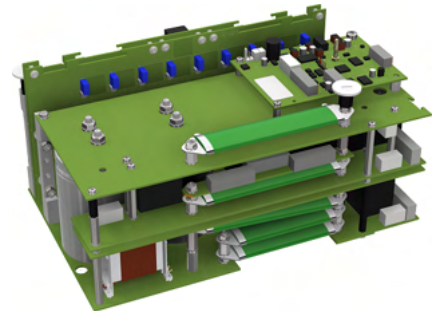

1.3.4 EXT-IMU3000 F5 (PN 106006) / F6 (PN 105680) / F7 (PN 108503)

EXT-IMU3000 F5 is an internal module for the IMU-MGE generator that extends its capabilities to EFT immunity tests according to IEC 61000-4-4 and voltages up to 5.1 kV. EXT-IMU3000 F6 is an internal module for the IMU-MGE generator that extends its capabilities to EFT immunity tests according to IEC 61000-4-4 and voltages up to 6.3 kV. EXT-IMU3000 F7 is an internal module for the IMU-MGE generator that extends its capabilities to EFT immunity tests according to IEC 61000-4-4 and voltages up to 7.1 kV.

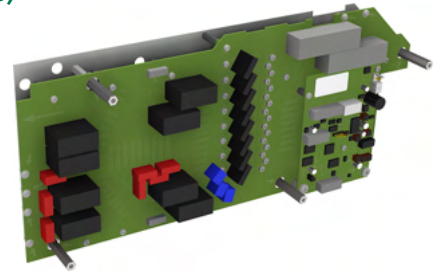

1.3.5 EXT-IMU3000 R6 (PN 106538) / R8 (PN 105682)

EXT-IMU3000 R6 is an internal module for the IMU-MGE generator that extends its capabilities to Ring Wave immunity tests according to IEC 61000-4-12 and voltages up to 6.6 kV.

EXT-IMU3000 R8 is an internal module for the IMU-MGE generator that extends its capabilities to Ring Wave immunity tests according to IEC 61000-4-12 and voltages up to 8.0 kV.

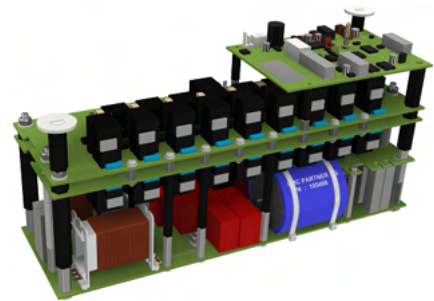

HEAD

1.3.6 EXT-IMU3000 T6 (PN 106537) / T8 (PN 105681)

EXT-IMU3000 T6 is an internal module for the IMU-MGE generator that extends its capabilities to Telecom Surge immunity tests with an 10/700 us impulse according to IEC 61000-4-5 and ITU-T K44 and voltages up to 6.6 kV.

EXT-IMU3000 T8 is an internal module for the IMU-MGE generator that extends its capabilities to Telecom Surge immunity tests with an 10/700 us impulse according to IEC 61000-4-5 and ITU-T K44 and voltages up to 8.0 kV.

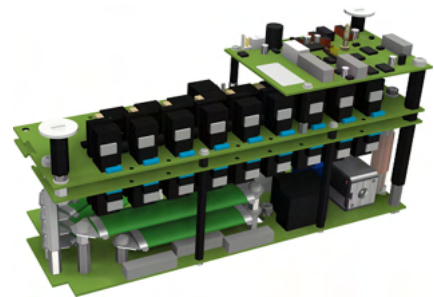

1.3.7 EXT-IMU V (PN 108234)

EXT-IMU V is an internal module for the IMU-MGS and IMU-MGE generators that extends the capabilities to voltage variations immunity tests according to IEC-61000-4-11. The maximum current is 5 A.

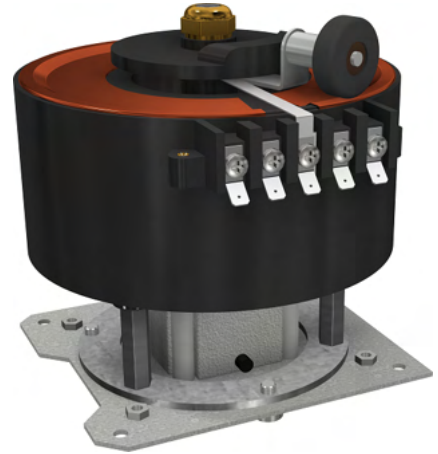

1.3.8 EXT-IMU D (PN 108235)

EXT-IMU D is an internal module for the IMU-MGS and IMU-MGE generators that extends the capabilities to voltage dips and interruptions up to 16 A according to IEC61000-4-11. Tests according to IEC61000-4-29 with currents exceeding 16 A require an additional power source.

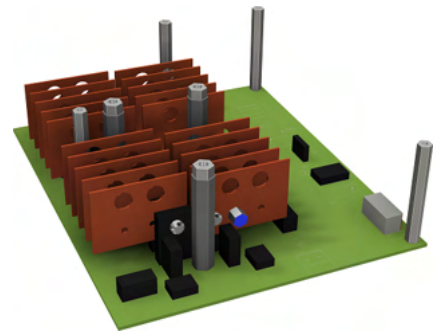

1.3.9 EXT-IMU C (PN 108236)

EXT-IMU C is an internal module for the IMU-MGS and IMU-MGE generators that extends the capabilities to common mode disturbance tests according to IEC 61000-4-16 at DC, 50/60/16.7 Hz and sinusoidal voltages up to 150 kHz and 35 V. For power tests, EXT-IMU C-SHORT and PS3 are required.

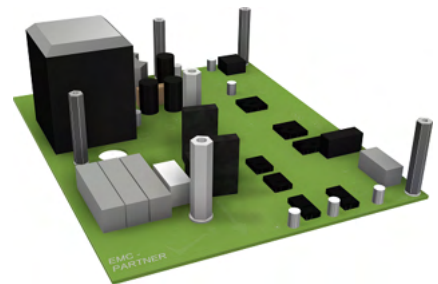

1.3.10 EXT-IMU P (PN 109975)

EXT-IMU P is an internal module for the IMU-MGS and IMU-MGE generators that extends the capabilities for power switching 300 Vdc / 16 A.

1.4 Power Line CDNs and Accessories

EMC PARTNER offers a wide range of coupling/decoupling networks (CDN) which extend the capabilities of the IMU-MGS and the IMU-MGE to couple Surge, EFT, and Ringwave pulses on three-phase AC voltages up to 690 V and DC voltages up to 1500 V. CDNs are available in current ranges of 32 A, 63 A, 125 A, and 200 A. Accessories include a wide variety of AC and DC overcurrent protection devices, as well as damping networks for DC applications.

1.4.1 **CDN-M-6-32 (PN 108652) and CDN-M-8-32 (PN 108657)**

Manual 3 phase CDN to be used together with EMC PARTNER generator IMU-MGS or IMU-MGE and a maximal pulse level of 6 kV (CDN-M-6-32) or 8 kV (CDN-M-8-32).

The basic version allows to superpose Surge and EFT pulses in accordance with latest editions of IEC 61000-4-4 and IEC 61000-4-5 on power lines up to 690 Vac and 500 Vdc. The basic functionality can be extended with several options:

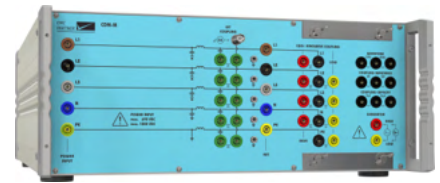

OPT-M-6-32 RWG (PN 108664) and OPT-M-8-32 RWG (PN 108665)

extends capability of CDN for Ring Wave tests according to IEC 61000-4-12

OPT-M-6-32 1000V DC (PN 108662) and OPT-M-8-32 1000V DC (PN 108663)

extends DC voltage capability from 500 V to 1000 V DC

1.4.2 **CDN-A-6-32 (PN 108653) and CDN-A-8-32 (PN 108658)**

Automatic 3 phase CDN to be used together with EMC PARTNER generator IMU-MGS or IMU-MGE and a maximal pulse level of 6 kV (CDN-A-6-32) or 8 kV (CDN-A-8-32).

The basic version allows to superpose Surge and EFT pulses in accordance with latest editions of IEC 61000-4-4 and IEC 61000-4-5 on power lines up to 690 Vac and 500 Vdc. The basic functionality can be extended with several options:

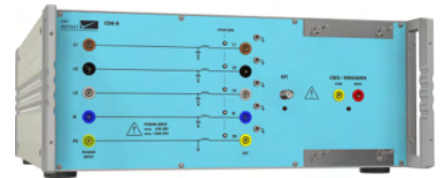

OPT-A-6-32 RWG (PN 108670) and OPT-A-8-32 RWG (PN 108671)

extends capability of CDN for Ring Wave tests according to IEC 61000-4-12

OPT-A-6-32 ANSI (PN 108672) and OPT-A-8-32 ANSI (PN 108673)

extends capability of CDN for ANSI couplings

OPT-A-6-32 1000V DC (PN 108666) and OPT-A-8-32 1000V DC (PN 108667)

extends DC voltage capability from 500 V to 1000 V DC

OPT-A-6-32 1500V DC (PN 108668) and OPT-A-8-32 1500V DC (PN 108669)

extends DC voltage capability from 500 V to 1500 V DC

1.4.3

CDN-A-6-63 (PN 108654) and CDN-A-8-63 (PN 108659)

Automatic 3 phase CDN to be used together with EMC PARTNER generator IMU-MGS or IMU-MGE and a maximal pulse level of 6 kV (CDN-A-6-63) or 8 kV (CDN-A-8-63). The basic version allows to superpose Surge and EFT pulses in accordance with latest editions of IEC 61000-4-4 and IEC 61000-4-5 on power lines up to 690 Vac and 500 Vdc. The basic functionality can be extended with several options:

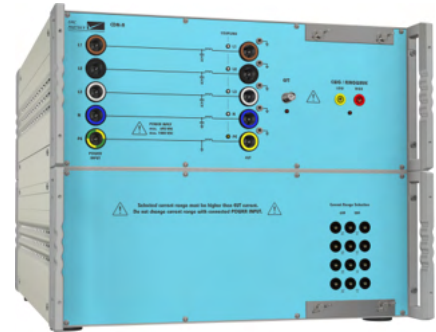

OPT-A-6-63 RWG (PN 108680) and OPT-A-8-63 RWG (PN 108692)

extends capability of CDN for Ring Wave tests according to IEC 61000-4-12

OPT-A-6-63 ANSI (PN 108683) and OPT-A-8-63 ANSI (PN 108693)

extends capability of CDN for ANSI couplings

OPT-A-6-63 FULL RANGE (PN 108687) and OPT-A-8-63 FULL RANGE (PN 108694)

ensure that surge waveform can be applied also when testing EUTs in current range 0-32 A

OPT-A-6-63 1000V DC (PN 108674) and OPT-A-8-63 1000V DC (PN 108690)

extends DC voltage capability from 500 V to 1000 V DC

OPT-A-6-63 1500V DC (PN 108677) and OPT-A-8-63 1500V DC (PN 108691)

extends DC voltage capability from 500 V to 1500 V DC

1.4.4

CDN-A-6-125 (PN 108655) and CDN-A-8-125 (PN 108660)

Automatic 3 phase CDN to be used together with EMC PARTNER generator IMU-MGS or IMU-MGE and a maximal pulse level of 6 kV (CDN-A-6-125) or 8 kV (CDN-A-8-125). The basic version allows to superpose Surge and EFT pulses in accordance with latest editions of IEC 61000-4-4 and IEC 61000-4-5 on power lines up to 690 Vac and 500 Vdc. The basic functionality can be extended with several options:

OPT-A-6-125 RWG (PN 108681) and OPT-A-8-125 RWG (PN 108697)

extends capability of CDN for Ring Wave tests according to IEC 61000-4-12

OPT-A-6-125 ANSI (PN 108684) and OPT-A-8-125 ANSI (PN 108698)

extends capability of CDN for ANSI couplings

OPT-A-6-125 FULL RANGE (PN 108688) and OPT-A-8-125 FULL RANGE (PN 108699)

ensure that surge waveform can be applied also when testing EUTs in current range 0-32 A and 32-63 A

OPT-A-6-125 1000V DC (PN 108675) and OPT-A-8-125 1000V DC (PN 108695)

extends DC voltage capability from 500 V to 1000 V DC

OPT-A-6-125 1500V DC (PN 108678) and OPT-A-8-125 1500V DC (PN 108696)

extends DC voltage capability from 500 V to 1500 V DC



1.4.5

CDN-A-6-200 (PN 108656) and CDN-A-8-200 (PN 108661)

Automatic 3 phase CDN to be used together with EMC PARTNER generator IMU-MGS or IMU-MGE and a maximal pulse level of 6 kV (CDN-A-6-200) or 8 kV (CDN-A-8-200). The basic version allows to superpose Surge and EFT pulses in accordance with latest editions of IEC 61000-4-4 and IEC 61000-4-5 on power lines up to 690 Vac and 500 Vdc. The basic functionality can be extended with several options:

OPT-A-6-200 RWG (PN 108682) and OPT-A-8-200 RWG (PN 108702)

extends capability of CDN for Ring Wave tests according to IEC 61000-4-12

OPT-A-6-200 ANSI (PN 108685) and OPT-A-8-200 ANSI (PN 108703)

extends capability of CDN for ANSI couplings

OPT-A-6-200 FULL RANGE (PN 108689) and OPT-A-8-200 FULL RANGE (PN 108704)

ensure that surge waveform can be applied also when testing EUTs in current range 0-32 A, 32-63 A and 63-125 A

OPT-A-6-200 1000V DC (PN 108676) and OPT-A-8-200 1000V DC (PN 108700)

extends DC voltage capability from 500 V to 1000 V DC

OPT-A-6-200 1500V DC (PN 108679) and OPT-A-8-200 1500V DC (PN 108701)

extends DC voltage capability from 500 V to 1500 V DC



1.4.6

CDN-F-xx

Manual 3 phase CDN to be used together with EMC PARTNER generator IMU-MGS or IMU-MGE. It allows to superpose EFT pulses in accordance with the latest edition of IEC 61000-4-4 on power lines up to 690 Vac.

- CDN-F-125 (PN 108569)

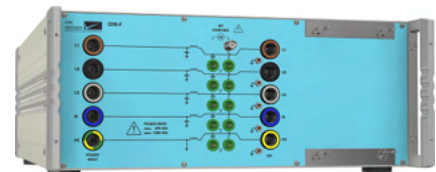

1.4.7

PROTxx-AC690 and PROTxx-DCyy

External Line Protection to protect the EUT against over-current. The protection is available for different current and voltage ratings.

PROT32-AC690 (PN 108729)

for 3-phase equipment up to 32 A and 690 Vac

PROT32-DC500 (PN 108730)

for DC equipment up to 32 A and 500 Vdc

PROT32-DC1000 (PN 108731)

for DC equipment up to 32 A and 1000 Vdc

PROT32-DC1500 (PN 108732)

for DC equipment up to 32 A and 1500 Vdc

PROT63-AC690 (PN 108733)

for 3-phase equipment up to 63 A and 690 Vac

PROT63-DC500 (PN 108735)

for DC equipment up to 63 A and 500 Vdc

PROT63-DC1000 (PN 108736)

for DC equipment up to 63 A and 1000 Vdc

PROT63-DC1500 (PN 108737)

for DC equipment up to 63 A and 1500 Vdc

PROT125-AC690 (PN 108738)

for 3-phase equipment up to 125 A and 690 Vac

PROT125-DC500 (PN 108739)

for DC equipment up to 125 A and 500 Vdc

PROT125-DC1000 (PN 108740)

for DC equipment up to 125 A and 1000 Vdc

PROT125-DC1500 (PN 108741)

for DC equipment up to 125 A and 1500 Vdc

PROT200-AC690 (PN 108742)

for 3-phase equipment up to 200 A and 690 Vac

PROT200-DC500 (PN 109357)

for DC equipment up to 200 A and 500 Vdc



1.4.8 DC-DCxx

The DC-DCxx is an optional damping circuit, consisting of a high performance diode and selectable resistors. DC-DCxx is designed to reduce oscillations in DC circuits when powering on EUT through a standard surge CDN conforming to IEC 61000-4-5. Four versions of the DC-DCxx are available for different current ranges.

DC-DC32 (PN 108609)

for up to 32 A continuous current

DC-DC63 (PN 108610)

for up to 63 A continuous current

DC-DC125 (PN 108611)

for up to 125 A continuous current

DC-DC200 (PN 108791)

for up to 200 A continuous current

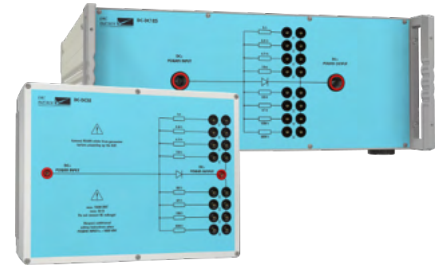

1.5 Data Line CDNs and Accessories

EMC PARTNER offers a range of data line CDNs for coupling of Surge and Ringwave pulses on communication lines and I/O ports. Different CDNs for asymmetrical or symmetrical communication lines are available with versions for 2 lines, 4 lines (2 pairs) or 8 lines (4 pairs).

1.5.1 CDN-DATA-4L (PN 107331)

The CDN-DATA-4L is a manual CDM that can be used together with EMC PARTNER IMU-MGS and IMU-MGE generators for Surge and Ringwave in order to superpose pulses on signal and data lines, in accordance with latest editions of IEC 61000-4-5 and IEC 61000-4-12. The CDN addresses 4 lines, asymmetrical, differential mode coupling (L-L) and common mode coupling (L-PE).

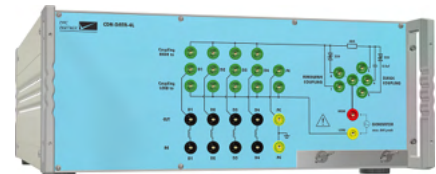

1.5.2 CDN-DATA-8L (PN 107332)

The CDN-DATA-8L is a manual CDM that can be used together with EMC PARTNER IMU-MGS and IMU-MGE generators for Surge and Ringwave in order to superpose pulses on signal and data lines, in accordance with latest editions of IEC 61000-4-5 and IEC 61000-4-12. The CDN addresses 8 lines, asymmetrical, differential mode coupling (L-L) and common mode coupling (L-PE).

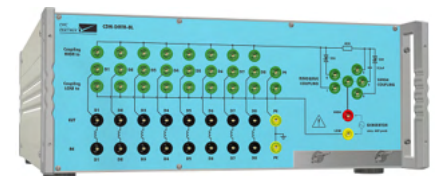

1.5.3 CDN-UTP ED3 (PN 106426)

The CDN-UTP ED3 is a manual CDN that can be used with EMC PARTNER IMU-MGS and IMU-MGE generators for Surge and Ringwave in order to superpose pulses on unshielded twisted signal and data lines, in accordance with the latest editions of IEC 61000-4-5 and IEC 61000-4-12. The CDN addresses 2 twisted pair lines (4 wires).

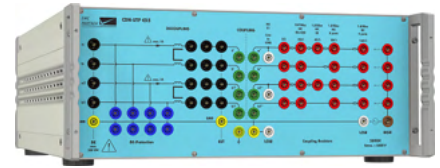

1.5.4 CDN-UTP8 ED3 (PN 106326)

The CDN-UTP8 ED3 is a manual CDN that can be used with EMC PARTNER IMU-MGS and IMU-MGE generators for Surge and Ringwave in order to superpose pulses on unshielded twisted signal and data lines, in accordance with the latest editions of IEC 61000-4-5 and IEC 61000-4-12. The CDN addresses 4 twisted pair lines (8 wires).

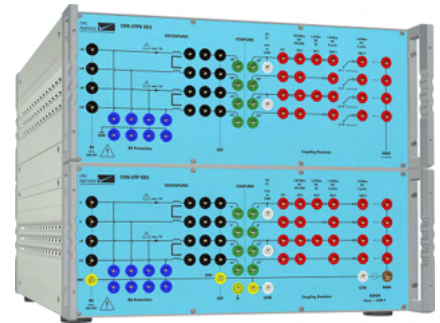

1.5.5 ADAPTER BOX RJ45 (PN 105839)

The ADAPTER BOX RJ45 extends the application of the CDN-UTP ED3 and CDN-UTP8 ED3 to symmetrical interconnection lines with RJ45 connectors and data rates up to 100 Mbit/s and 1 Gbit/s. The CDN-UTP ED3 requires 2 adapter boxes and the CDN-UTP8 ED3 requires 4 adapter boxes.



1.5.6 CDN-KIT1000 ED3 (PN 106425)

The CDN-KIT1000 ED3 is a manual and modular CDN that can be used with EMC PARTNER IMU-MGS and IMU-MGE generators for Surge in order to superpose pulses on signal and data lines, in accordance with the latest edition of IEC 61000-4-5. THE CDN addresses 2 lines asymmetrical, differential mode coupling (L-L) and common mode coupling (L-PE).



1.6 Accessories for IEC 61000-4-2: ESD

EMC PARTNER offers "EXT-IMU E" and various accessories to extend the capabilities of IMU-MGS and IMU-MGE to electrostatic discharge (ESD) testing up to 16 kV according to the latest edition of IEC 61000-4-2.

1.6.1 EXT-IMU E (PN 108233)

The EXT-IMU E is an external accessory to extend the capabilities of IMU-MGS or IMU-MGE for electrostatic discharge (ESD) testing up to 16 kV.



1.6.2 ESD-TARGET2 (PN 103630)

The ESD-TARGET2 is a 20 Ohm Target according to IEC 61000-4-2. It features an SMA connector and an upper bandwidth limit >3 GHz. It is intended for ESD calibration, verification and comparison. It includes a calibrated target attenuator cable chain for up to 10 kV.



1.6.3 ESD-VERI-V (PN 103629)

The ESD-VERI-V is a charging voltage measurement divider with a resistance of 20 GOhm for charging voltages up to 32 kV. The divider ratio is approximately 1:20'000 and is determined by the 1 MOhm input of the oscilloscope.



1.6.4 ESD-STAND ED2 (PN 103637)

The ESD-STAND ED2 is a mechanical stand for the EXT-IMU E, in accordance with the latest edition of IEC 61000-4-2.



1.6.5 ESD-VCP50 (PN 103485)

The ESD-VCP50 is a vertical coupling plate with dimensions of 0.5 m x 0.5 m, in accordance with the latest edition of IEC 61000-4-2. It includes an EARTH CABLE.



1.6.6 EARTH CABLE (PN 103141)

The EARTH CABLE is a 2 m connection cable featuring 2 470 kOhm bleeder resistors for use up to 30 kV with the vertical or horizontal coupling plane, in accordance with the latest edition of IEC 61000-4-2.

1.7 Accessories for IEC 61000-4-4: EFT/Burst

EMC PARTNER offers a wide range of accessories for Electrical Fast Transient (EFT)/Burst immunity tests with IMU-MGS and IMU-MGE according to the latest edition of IEC 61000-4-4.

1.7.1 CN-EFT1000 (PN 103468)

The CN-EFT1000 is a capacitive coupling clamp according to the latest editions of basic standards IEC 61000-4-4, IEC 61000-4-18 and product standard ANSI C37.90.1.

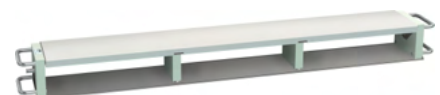

1.7.2 VERI50 EFT (PN 103472)

The VERI50 EFT is a 50 Ohm termination with high voltage SHV-BNC connector, and integrated measurement divider for EFT calibration and verification. It is designed for EFT calibration up to 7 kV.

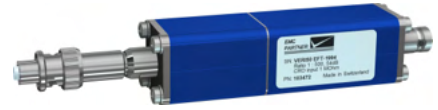

1.7.3 VERI1K EFT (PN 103473)

The VERI1K EFT is a 1 kOhm termination with high voltage SHV-BNC connector, and integrated measurement divider for EFT calibration and verification. It is designed for EFT calibration up to 7 kV.



1.7.4 VERI-CP-EFT (PN 104668)

The VERI-CP-EFT is a transducer plate for CN-EFT1000 capacitive coupling clamp calibration. The plate has a high voltage SHV-BNC connector and a 15 cm strap to bond to the reference ground. It requires a VERI50 EFT.



1.7.5 EFT INSULATION (PN 103658)

EFT INSULATION is a set of two 10 cm isolation supports for EFT testing according to IEC 61000-4-4.



1.7.6 CN-BALUN-AC (PN 107600)

The CN-BALUN-AC is a balanced transmission line transformer designed to convert EFT generators with 50 ohm output to a 200 ohm differential output. This enables application of the EFT impulse to AC power lines in accordance with standard ANSI/IEEE C37.90 Figure 6. It features two built-in 66 nF decoupling capacitors.



1.8 Accessories for IEC 61000-4-5: Surge, and IEC 61000-4-12: Ringwave

EMC PARTNER offers the following accessories for Surge immunity tests with IMU-MGS and IMU-MGE according to the latest edition of IEC 61000-4-5 and Ringwave immunity tests with IMU-MGE according to the latest edition of IEC 61000-4-12

1.8.1 CN-R40C05 (PN 104931) and CN-R40C05 8 (PN 109112)

The CN-R40C05 is a coupling network to couple Surge pulses on data lines or low power supply lines according to IEC 61000-4-5 and EN50121-4. It features two individual circuits, each with a 40 Ohm resistor and a 0.5 uF capacitor. CN-R40C05 can be used for Surge pulses up to 6 kV, whereas CN-R40C05 8 can be used for Surge pulses up to 8 kV.

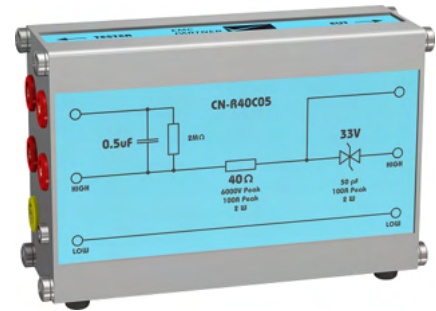

1.8.2 V-PROBE-SI (PN 105107)

The V-PROBE-SI is a differential voltage probe with a system bandwidth from DC up to 70 MHz. The maximum voltage rating is ± 7000 V peak or ± 2000 Vrms. It can be used for measuring Surge or Ring Wave impulses.

1.8.3 I-PROBE-P101 (PN 106683)

The I-PROBE-P101 is a current monitor probe for cables with a diameter of up to 5 cm. The maximum current rating is 5 kA peak current and a bandwidth from 0.25 Hz to 4 MHz. The transducer ratio is 0.01 V/A.

1.9 Accessories for IEC 61000-4-8/-9: Magnetic Field

EMC PARTNER offers the following accessories to extend the capabilities of IMU-MGS and IMU-MGE for power frequency magnetic field immunity tests according to the latest edition of IEC 61000-4-8 and impulse magnetic field immunity tests according to the latest edition of IEC 61000-4-9.

1.9.1 MF1000-1 (PN 103480)

The MF1000-1 is a coil with dimensions of 1 m x 1 m for magnetic field tests according to the latest editions of IEC 61000-4-8, IEC 61000-4-9, and IEC 61000-4-10.



1.9.2 MF1000-2 (PN 103481)

The MF1000-2 is a coil with dimensions of 1 m x 2.6 m for magnetic field tests according to the latest editions of IEC 61000-4-8, IEC 61000-4-9, and IEC 61000-4-10.

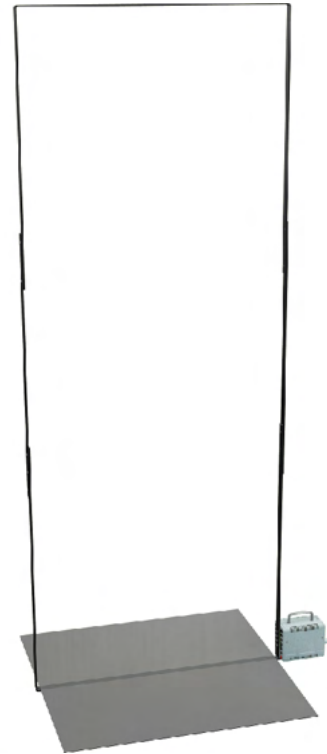

1.9.3 MF1000-3 (PN 103482)

The MF1000-3 is a coil with dimensions of 1 m x 1 m for magnetic field tests of short duration of up to 3 s according to IEC 61000-4-8.



1.9.4 MF1STAND (PN 103483)

The MF1STAND is a stand for mechanical support of the MF1000-1 coil. It is moveable in all three directions with a maximal height of 1.8 m.



1.9.5 MF3STAND (PN 103484)

The MF3STAND is a stand for mechanical support of the MF1000-3 coil. It is moveable in all three directions with a maximal height of 1.8 m.



1.9.6 VAR-EXT1000 (PN 103470)

VAR-EXT1000

1.10 Accessories for IEC 61000-4-11/-34: AC Dips, Interrupts and Variations

EMC PARTNER offers a wide range of accessories to extend the capabilities of IMU-MGS and IMU-MGE to perform voltage dips, short interruptions and voltage variations immunity tests on three-phase supply lines according to the latest editions of IEC 61000-4-11 and IEC 61000-4-34.

1.10.1 VAR-EXT1000 (PN 103470)

The VAR-EXT1000 is a 16 A external variac which extends the capabilities of the IMU-MGS and IMU-MGE generators for AC dips, interrupts and variations testing up to 16 A according to the latest edition of IEC 61000-4-11.

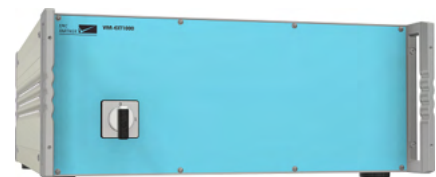

1.10.2 VERI-DIPS (PN 103474)

The VERI-DIPS is a circuit for inrush current measurements according to IEC 61000-4-11. It can be used with IMU generators together with PFS32 and PFS75.

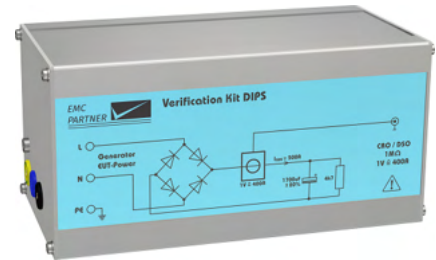

1.10.3 DIPS100E (PN 103643)

DIPS100E is a 100 Ohm resistor ($\pm 5\%$ and 1kW power rating) for switching time calibration according to IEC 61000-4-11. It can be used with IMU generators together with PFS32 and PFS75.

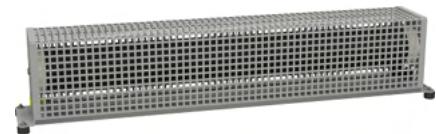

1.10.4 SRC16-1P (PN 108366)

The SRC16-1P is a single phase dip transformer up to 300 Vac and 16 A for tests according to IEC 61000-4-11 with manual switching of the dip level of 40%, 70%, 80% or 100%.

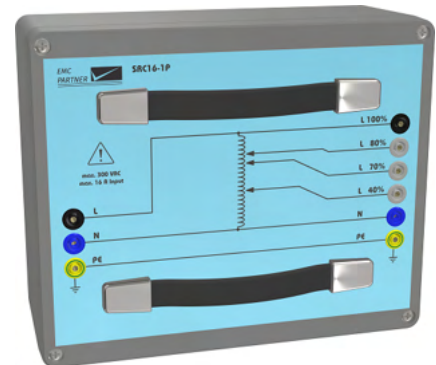

1.10.5 PFS32 (PN 103670)

THE PFS32 can generate interruptions on three phase power supply lines up to 480 V/32 A. For supply configuration, the PFS32 can be inserted in the SRC32 Rack

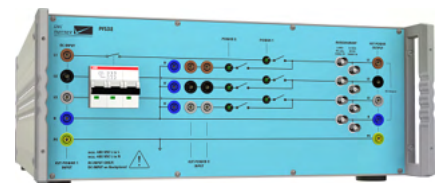

1.10.6 SRC32-18UH (PN 103671) and SRC32-AMD1 (PN 104871)

The SRC32-18UH is a 18 Unit High rack with a three phase transformer for 3 phase dips at 40%, 70% and 80% levels. The rack can house as well the PFS32.



1.10.7 PFS75 (PN 103701) and PFS75-690V (PN 105847)

The PFS75 can generate interruptions on three phase power supply lines up to 480 V/75 A. THE PFS75 can generate interruptions on three phase power supply lines up to 690 V/75 A. For supply configuration, the PFS75 or PFS75-690V can be inserted in the SRC75 Rack

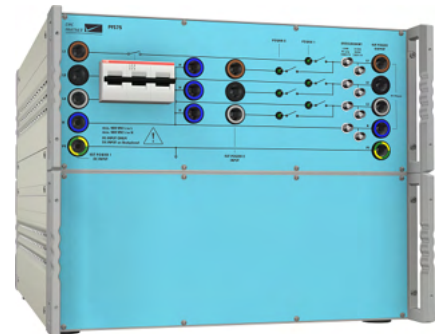

1.10.8 SRC75-18UH (PN 103702) and SRC75-690V (PN 105848)

The SRC75-18UH is a 18 Unit High rack with a three phase transformer for 3 phase dips at 40%, 70% and 80% levels on 480 V/75 A mains. The SRC75-690V allows 3 phase dips at 40%, 70% and 80% levels on 690 V/75 A mains. The rack can house as well the PFS75 or PFS75-690V.



1.11 Accessories for IEC 61000-4-29: DC Dips, Interrupts and Variations

EMC PARTNER offers a range of accessories to extend the capabilities of IMU-MGS and IMU-MGE to perform voltage dips, short interruptions and voltage variations immunity tests on DC input power ports according to the latest edition of IEC 61000-4-29.

1.11.1 VERI-DIPS (PN 103474)

See VERI-DIPS

1.11.2 DIPS100E (PN 103643)

See DIPS100E

1.11.3 EXT-IMU D-29D (PN 108238)

EXT-IMU D-29D extends the IMU-MGS or IMU-MGE for DC dips and interrupts according to IEC 61000-4-29. It requires two PS3, two RS485-RS232 ADAPTER, and two RESISTOR 50.

1.11.4 EXT-IMU D-29I (PN 108239)

EXT-IMU D-29D extends the IMU-MGS or IMU-MGE for DC interrupts according to IEC 61000-4-29. It requires one PS3, one RS485-RS232 ADAPTER, and one RESISTOR 50.

1.11.5 RESISTOR 50 Ohm (PN 108145)

50 Ohm resistor ($\pm 5\%$ and 1 kW power rating) used as calibration load for EXT-IMU D29-D.

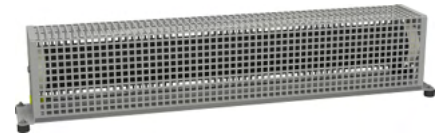

1.11.6 PS3 (PN 103497)

The PS3 is a versatile and easy-to-use programmable power supply from EMC PARTNER with a rated power of up to 3000 VA. It is able to generate DC output voltages and AC output voltages up to frequencies of 400 Hz in the range from ± 10 V up to ± 350 V with very high accuracy. Pre-programmed output voltages are 230 V/50 Hz, 230 V/16.7 Hz, 115 V/60 Hz and 115 V/400 Hz.

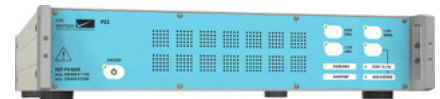

1.11.7 RS485-RS232 ADAPTER (PN 104770)

The RS485-RS232 ADAPTER is a serial converter from RS485 to RS232 and cable that is used to control the PS3 power supply by the IMU-MGS or IMU-MGE generators.



1.12 Accessories for IEC 61000-4-16: Common Mode

EMC PARTNER offers a wide range of accessories, coupling and decoupling networks to extend the capabilities of IMU-MGS and IMU-MGE to test for immunity to conducted, common mode disturbances in the frequency range 0 Hz to 150 kHz according to the latest edition of IEC 61000-4-16.

1.12.1 PS3 (PN 103497)

See PS3

1.12.2 RS485-RS232 ADAPTER (PN 104770)

See RS485-RS232 ADAPTER

1.12.3 EXT-IMU C-SHORT (PN 108237)

The EXT-IMU C-SHORT extends the capabilities of IMU-MGS and IMU-MGE for short tests according to the latest edition of IEC 61000-4-16. It requires one PS3 and one RS485-RS232 ADAPTER.

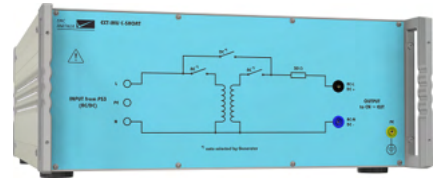

1.12.4 CN16 (PN 103538)

The CN16 is a coupling network for common mode coupling according to IEC 61000-4-16. It couples a large range of disturbance signals (DC, 50/60/16.7 Hz and sinusoidal up to 150 kHz) to EUTs with up to 4 lines. The coupling network is suitable for power supply and input/output ports.

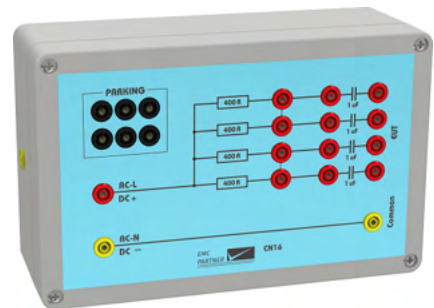

1.12.5 CN16-300 (PN 109355)

The CN16-300 is a coupling network for common mode coupling according to IEC 61000-4-16. It couples a large range of disturbance signals (DC, 50/60/16.7 Hz and sinusoidal up to 150 kHz) to EUTs with 3 power lines.

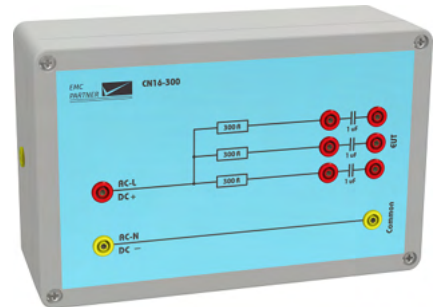

1.12.6 CN16DC (PN 106900)

The CN16DC is a coupling network for common mode coupling according to IEC 61000-4-16. It couples DC disturbance signals to EUTs with 2 high power lines.

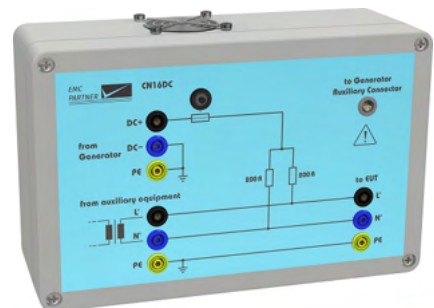

1.12.7 CN16-8L (PN 108391)

The CN16-8L is a coupling network for common mode coupling according to IEC 61000-4-16. It couples a large range of disturbance signals (DC, 50/60/16.7 Hz and sinusoidal up to 150 kHz) to EUTs with up to 8 lines. The coupling network is suitable for power supply and input/output ports.

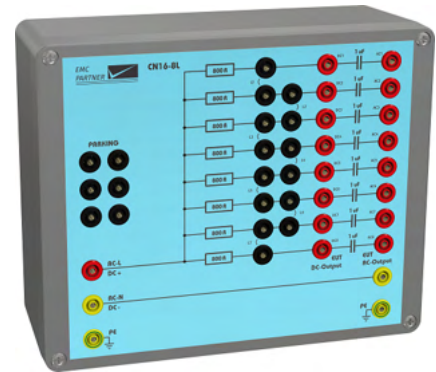

1.12.8 CN16T (PN 103539)

The CN16T is a coupling network for common mode coupling according to IEC 61000-4-16. It couples a large range of disturbance signals (DC, 50/60/16.7 Hz and sinusoidal up to 150 kHz) to an EUTs one balanced communication pair (2 wires).

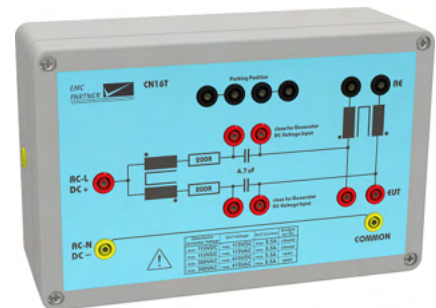

1.12.9 CN16T4 (PN 106849)

The CN16T4 is a coupling network for common mode coupling according to IEC 61000-4-16. It couples a large range of disturbance signals (DC, 50/60/16.7 Hz and sinusoidal up to 150 kHz) to an EUTs two balanced communication pairs (4 wires).

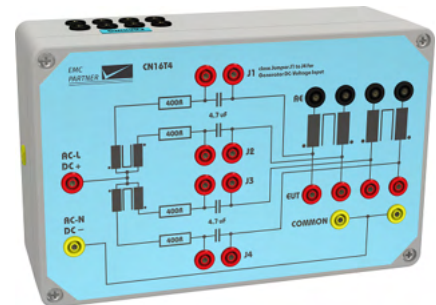

1.12.10 CN16T8 (PN 109658)

The CN16T8 is a coupling network for common mode coupling according to IEC 61000-4-16. It couples a large range of disturbance signals (DC, 50/60/16.7 Hz and sinusoidal up to 150 kHz) to an EUT with RJ45 ethernet connectors, i.e. 4 balanced communication pairs (8 wires).

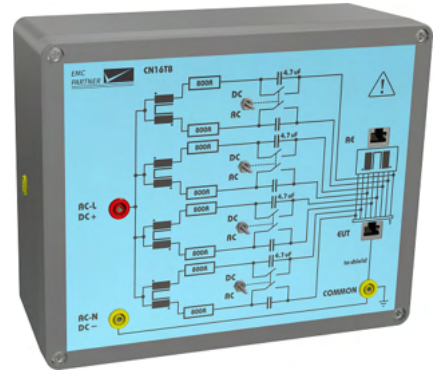

1.12.11 CN16-22-7C (PN 105840)

The CN16-22-7C is a coupling network for common mode coupling up to 300 V 50/60 Hz according IEC 60255-22-7 and IEC 60255-26. It features two ports, each one featuring 2 220 Ohm resistors and 2 0.47 uF capacitors.

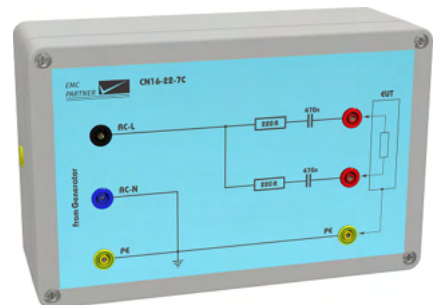

1.12.12 CN16-22-7D (PN 105841)

The CN16-22-7D is a coupling network for differential mode coupling up to 250 V 50/60 Hz according IEC 60255-22-7 and IEC 60255-26. It features two ports, each one featuring 2 100 Ohm resistors and 2 0.1 uF capacitors.

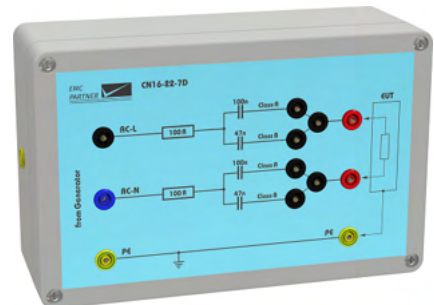

1.12.13 DN16-1P16 and DN16-1P6 (PN 106962)

The DN16-1P16 is a single phase 230 V/16 A 50/60 Hz mains decoupling transformer for testing according to IEC 61000-4-16.

The DN16-1P6 is a single phase 230 V/6 A 50/60 Hz mains decoupling transformer for testing according to IEC 61000-4-16.

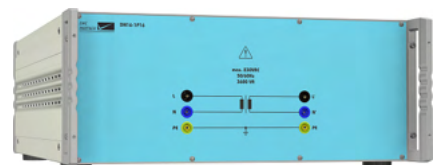

1.13 Accessories for IEC 61000-4-19: Differential Mode

EMC PARTNER offers accessories to extend the capabilities of IMU-MGS and IMU-MGE to test for immunity to conducted, differential mode disturbances and signalling in the frequency range 2 kHz to 150 kHz at AC power ports according to the latest edition of IEC 61000-4-19.

1.13.1 IMU SLAVE SMART I1V1 (PN 105685)

The IMU SLAVE SMART I1V1 extends the capabilities of IMU-MGS and IMU-MGE to differential mode testing according to IEC 61000-4-19. It consists of a current and a voltage disturbance generator part. The current disturbance generator part is able to generate disturbances from 2 kHz up to 150 kHz with amplitudes up to 4.4 A, and features an integrated load current source up to 25 A. The voltage disturbance generator part is able to generate disturbances from 2 kHz up to 150 kHz with amplitudes up to 25 V, and features an integrated single-phase CDN up to 16 A.

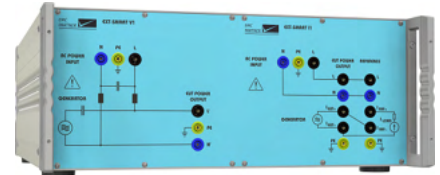

1.13.2 IMU SLAVE SMART I1 (PN 107128)

The IMU SLAVE SMART I1 extends the capabilities of IMU-MGS and IMU-MGE to differential mode testing according to IEC 61000-4-19. It consists of only the current disturbance generator part, able to generate disturbances from 2 kHz up to 150 kHz with amplitudes up to 4.4 A, and features an integrated load current source up to 25 A.

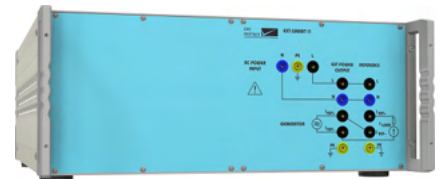

1.13.3 IMU SLAVE SMART V1 (PN 107129)

The IMU SLAVE SMART V1 extends the capabilities of IMU-MGS and IMU-MGE to differential mode testing according to IEC 61000-4-19. It consists of only the voltage disturbance generator part able to generate disturbances from 2 kHz up to 150 kHz with amplitudes up to 25 V, and features an integrated single-phase CDN up to 16 A.

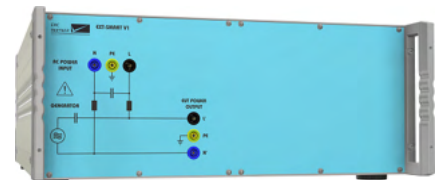

1.13.4 VERI10-50 (PN 107494)

The VERI10-50 consists of two 10 Ohm-to-50 Ohm Baluns with BNC connectors for connection to a vector network analyzer. It is designed to verify the CDN characteristics of the IMU SLAVE SMART V1 according to IEC 61000-4-19.



1.14 General Accessories

1.14.1 EMERGENCY-STOP (PN 109773)

EMERGENCY-STOP is a remote emergency stop button, with 5 m cable, allowing the user to safely shut down the generator from a distance in case of an emergency.



1.14.2 WARNING-LAMP (PN 109775)

WARNING LAMP is an external warning lamp with red and green indicators, which provides additional visual information to see if the generator's safety circuit is open or closed. It comes with a magnetic foot to fix it on metallic surfaces, a mounting angle, as well as a 3 m extension cable.



2 Initial Operation

2.1 Unpacking and Checking

1. Check the packaging for signs of damage. If damage is visible, report this to the shipping company immediately.
2. Gently remove the equipment from the packaging.
3. Check the delivery for completeness using the delivery note and the accessory lists for the various items. If something is missing, contact EMC PARTNER or your local sales representative immediately.
4. Check the equipment for any damage. If there is damage, immediately contact the shipping company who made the delivery.



Retain the original packing material for a safe transport at a later date.

2.2 Installation

The equipment is designed for use under laboratory conditions. Make sure that all fan openings are unobstructed, that the airflow perforations are unimpeded, and that the minimum distance from the wall is 10cm. An insufficient airflow can cause the equipment to overheat, which may disturb the operation and even cause damage.



Most equipment from EMC PARTNER can be mounted in a 19" Rack. A special rack mounting kit is available. Contact your local sales representative for a quotation.

2.3 Powering the Equipment

Check that the local AC-supply is suitable for the equipment. Power rating of the instrument is indicated on the type plate next to the AC power supply connector located on the rear panel. Only use the supplied power cord to connect to your public power supply.



The equipment must always be connected to protective earth. Check the earth connection on your power outlet before you connect and turn on the equipment.

2.4 Safety Circuit

The generator is equipped with a safety circuit. As long as the safety circuit is open, no test can be started. To close the safety circuit

1. connect the auxiliary connector on the rear panel
2. pull out the emergency stop button on the front panel with a slight turn clockwise

A closed safety circuit is indicated by a red illuminated emergency stop button

3 Hardware Description

This chapter provides a short description of the main hardware features of the EMC PARTNER IMU-MGS and IMU-MGE generators.

3.1 IMU-MGS

In the following sections the front panel and rear panel of the IMU-MGS generator are described.

3.1.1 Front Panel

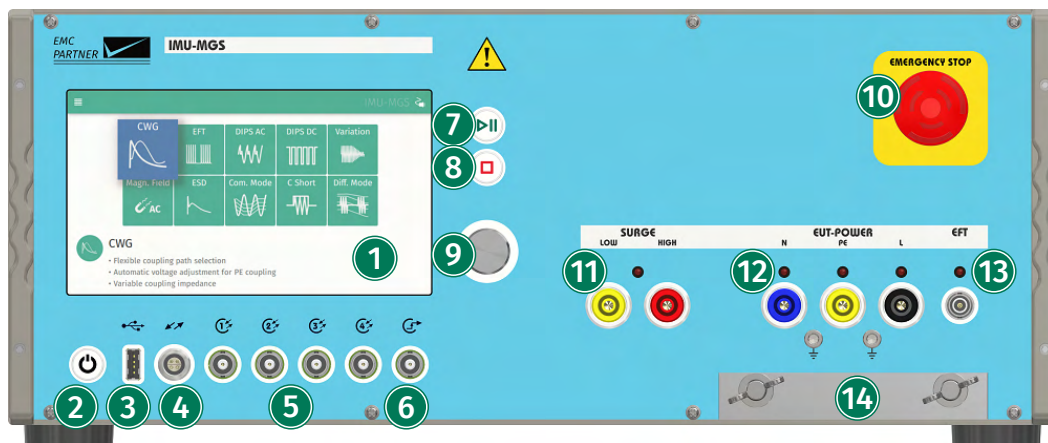

- ① **Touchscreen Monitor**
User interface to perform all functions including test types selection, parameter entry, saving and recalling tests.
- ② **On/Off/Standby Button**
Power up or power down the generator.
- ③ **USB Port**
Connect a USB memory stick to copy files (setups, protocols, error logs) from the generator. The USB interface is also used to update the internal firmware.
- ④ **Auxiliary Connection**
Interface for additional external equipment.
- ⑤ **BNC Inputs/Outputs**
BNC connectors are either measurement outputs for direct connection to an oscilloscope for monitoring various voltages and currents or freely configurable inputs/outputs. Please refer to the chapter Connectors for additional information.
 - BNC1: Voltage measurement at the EUT power output (CDN output)
 - BNC2: Current measurement at the EUT power output (CDN output)
 - BNC3: Voltage measurement at the Impulse output (Surge output)
 - BNC4: Current measurement at the Impulse output (Surge output)
- ⑥ **BNC Trigger Output**
BNC output for a direct connection to the scope to start pulse acquisition. Level and duration depend on the specific test. Some typical values are

- 6 V Impulse trigger
- 4 V EUT Power 1 state
- 2 V EUT Power 2 state

7 Run/Pause Button

Starts or pauses the selected test.
A green blinking LED indicates a running test.

8 Stop Button

Stops the selected test.
A red blinking LED indicates a stopped test due to an error.
A red LED indicates a finished test.

9 Rotary Knob

Entry device enables fast navigation and parameter entry.

10 Emergency Stop

Push to open the safety circuit. As soon as the safety circuit is open, all running tests are immediately stopped. No more tests can be started.
Release the emergency stop button with a slight turn clockwise. A closed safety circuit is indicated by a red illuminated emergency stop button.

11 Surge Impulse Direct Output

Direct output for the surge impulse. It is used for calibration, direct connection to an EUT and connection to accessories like magnetic field antennas or external coupling/decoupling networks.

12 EUT Power Output

Connection for the EUT. EMC PARTNER offers adapters for the different types of power cord connectors for different countries.

13 EFT Impulse Direct Output

Direct output for the electrical fast transient (EFT) impulse. It is used for calibration, direct connection to an EUT and connection to accessories like a capacitive coupling clamp or external coupling/decoupling networks.

14 Protective Earth Connection

The earth terminal allows for a proper connection between test equipment and the reference ground plane to be made. Particularly for interference tests with high frequency components, such as EFT, a large surface earth connection is necessary.

3.1.2 Rear Panel

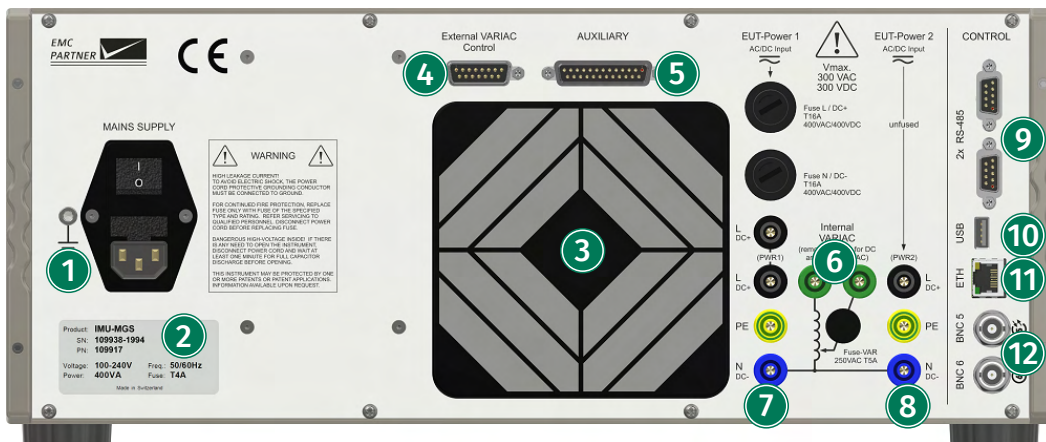

1 AC Socket / Mains Connection

A country specific mains cable is delivered with the equipment, this should be used to connect to the mains power supply. A mains fuse is located in the socket housing. The value is indicated on the equipment type plate.



Take care to ensure the power mains matches the power ratings on the equipment type plate.

The generator must always be connected to protective earth.

2 Device Information Panel

Product name, serial number (SN), product number (PN), and input power requirements.

3 Rear Fan

Rear cooling fan. Take care not to obstruct the opening to assure proper airflow through the generator and prevent overheating.

4 External Variac Control

Via this special interface, the external variac can be controlled by the generator.

5 Auxiliary Connection

Fit the auxiliary connector delivered with the equipment, to close the safety circuit.

It is possible to extend the safety circuit or to connect additional external warning lamps.

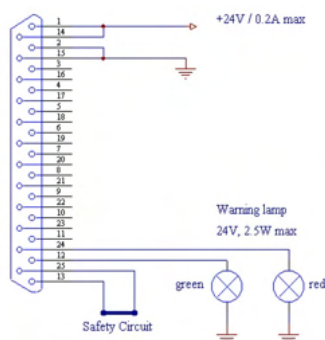

- The green lamp indicates safety circuit open, no test can be started
- The red lamp indicates safety circuit closed, tests can be started

6 Internal Variac Connection

If available, the internal variac (EXT-IMU V) is connected between power input 1 and power input 2. The connections is made with two MC bridges.



DC supply

If the generator is fed with DC, the two bridges must be removed to disconnect the internal variac.

7 EUT Power Input 1

All input plugs and fuses for EUT Power 1 are located in a row. The two 16 A fuses for phase and neutral located above. Below the fuses are the three power line connections for the EUT power supply.



DC supply

The Module EXT-IMU D or EXT-IMU P must be fitted for dc applications.



For continued fire protection, replace the fuse only with fuse of the specified type and rating. Refer servicing to qualified personnel. Disconnect the power cord before replacing fuse.

8 EUT Power Input 2

Input for the power level during interruption. When an external source, for example an external variac or an external ac/dc source (PS3), is used, the source must be connected to these inputs.



DC supply

The Module EXT-IMU D or EXT-IMU P must be fitted for dc applications.

9 RS485 Interfaces

Interfaces to connect additional equipment that is controlled directly from the test equipment.

10 USB Port

Connect a USB memory stick to copy files (setups, protocols, error logs) from the generator. The USB interface is also used to update the internal firmware.

11 Ethernet Interface

Remote control using TEMA3000 software via a common Ethernet interface.

12 BNC Inputs/Outputs

Two freely programmable BNC connectors.

Please refer to the chapter Connectors for additional information.

3.2 IMU-MGE

In the following sections the front panel and rear panel of the IMU-MGE generator are described.



Note that the hardware characteristics of the IMU-MGE and IMU-MGS generators are very similar, they have the same user interface, as well as inputs and outputs. The only (external) difference between the IMU-MGS and the IMU-MGE are the mechanical size. Therefore in the rest of this user manual, we will limit the images of the hardware setups to the IMU-MGS, the setups for the IMU-MGE are identical (unless explicitly stated otherwise).

3.2.1 Front Panel

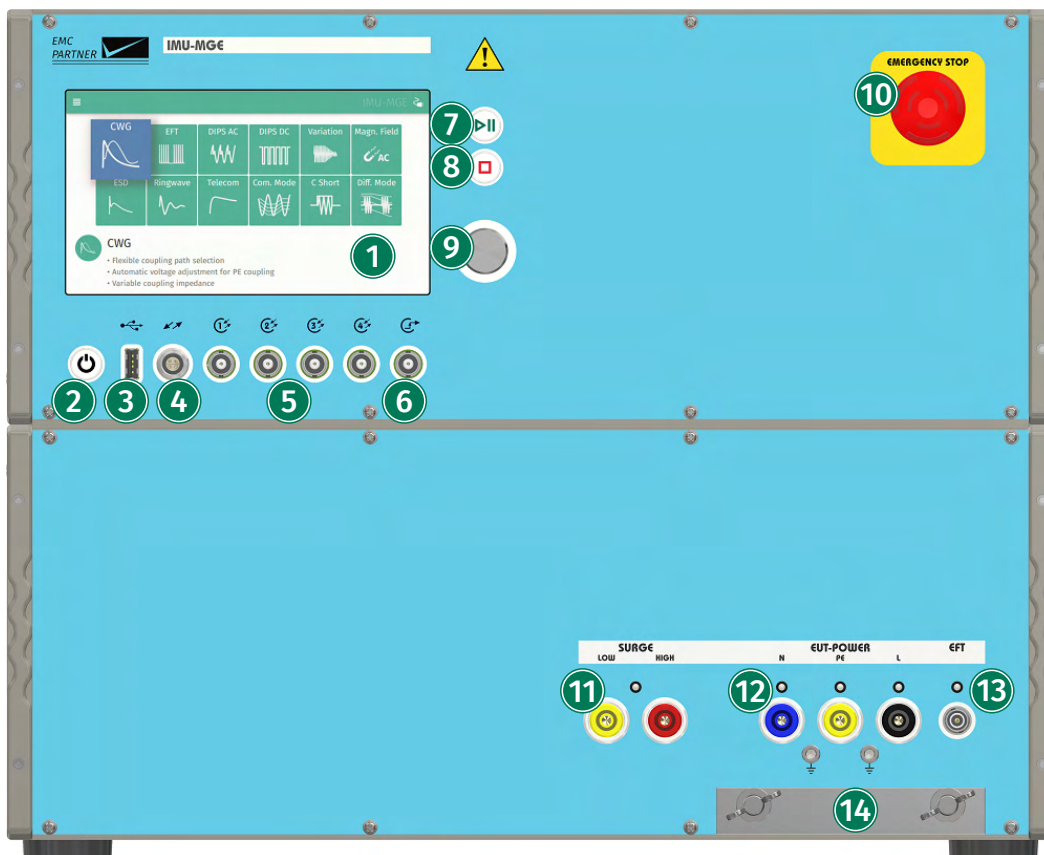

- 1 Touchscreen Monitor**
User interface to perform all functions including test types selection, parameter entry, saving and recalling tests.
- 2 On/Off/Standby Button**
Power up or power down the generator.
- 3 USB Port**
Connect a USB memory stick to copy files (setups, protocols, error logs) from the generator. The USB interface is also used to update the internal firmware.
- 4 Auxiliary Connection**
Interface for additional external equipment.

5 BNC Inputs/Outputs

BNC connectors are either measurement outputs for direct connection to an oscilloscope for monitoring various voltages and currents or freely configurable inputs/outputs. Please refer to the chapter Connectors for additional information.

- BNC1: Voltage measurement at the EUT power output (CDN output)
- BNC2: Current measurement at the EUT power output (CDN output)
- BNC3: Voltage measurement at the Impulse output (Surge output)
- BNC4: Current measurement at the Impulse output (Surge output)

Please refer to the chapter Connectors for additional information.

6 BNC Trigger Output

BNC output for a direct connection to the scope to start pulse acquisition. Level and duration depend on the specific test. Some typical values are

- 6 V Impulse trigger
- 4 V EUT Power 1 state
- 2 V EUT Power 2 state

7 Run/Pause Button

Starts or pauses the selected test.
A green blinking LED indicates a running test.

8 Stop Button

Stops the selected test.
A red blinking LED indicates a stopped test due to an error.
A red LED indicates a finished test.

9 Rotary Knob

Entry device enables fast navigation and parameter entry.

10 Emergency Stop

Push to open the safety circuit. As soon as the safety circuit is open, all running tests are immediately stopped. No more tests can be started.
Release the emergency stop button with a slight turn clockwise. A closed safety circuit is indicated by a red illuminated emergency stop button.

11 Surge Impulse Direct Output

Direct output for the surge impulse. It is used for calibration, direct connection to an EUT and connection to accessories like magnetic field antennas or external coupling/decoupling networks.

12 EUT Power Output

Connection for the EUT. EMC PARTNER offers adapters for the different types of power cord connectors for different countries.

13 EFT Impulse Direct Output

Direct output for the electrical fast transient (EFT) impulse. It is used for calibration, direct connection to an EUT and connection to accessories like a capacitive coupling clamp or external coupling/decoupling networks.

14 Protective Earth Connection

The earth terminal allows for a proper connection between test equipment and the reference ground plane to be made. Particularly for interference tests with high frequency components, such as EFT, a large surface earth connection is necessary.

3.2.2 Rear Panel

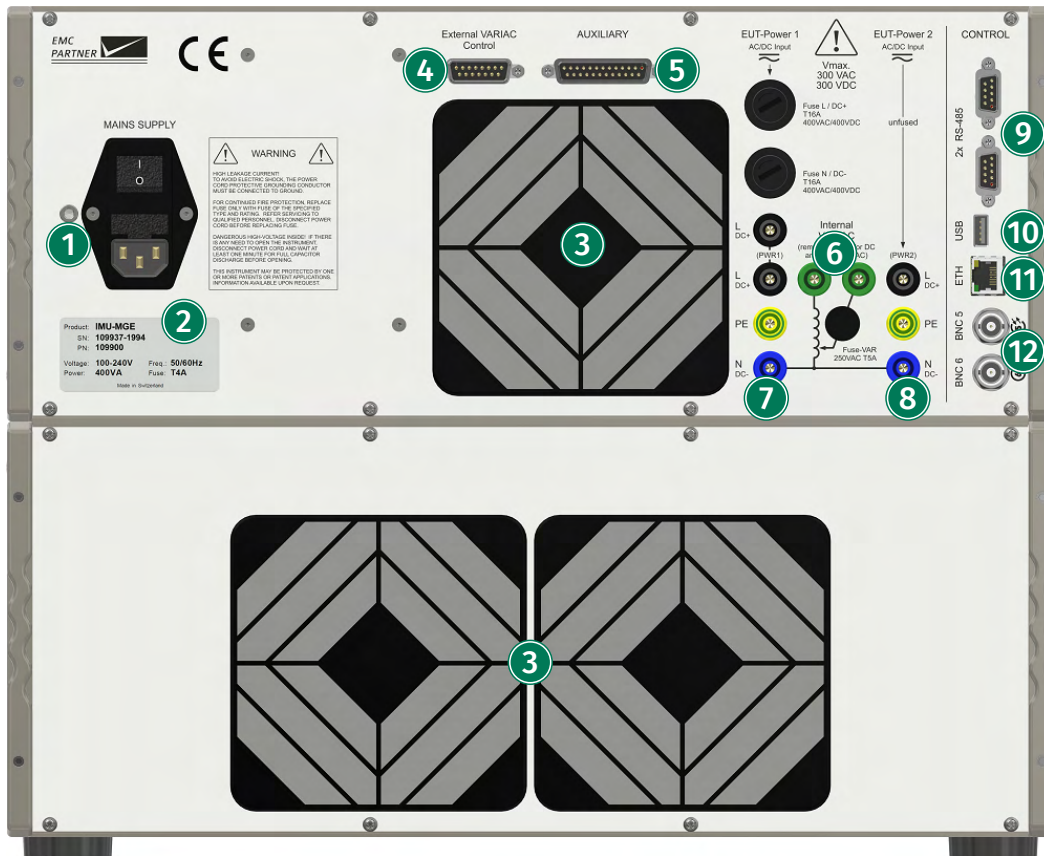

1 AC Socket / Mains Connection

A country specific mains cable is delivered with the equipment, this should be used to connect to the mains power supply. A mains fuse is located in the socket housing. The value is indicated on the equipment type plate.



Take care to ensure the power mains matches the power ratings on the equipment type plate.

The generator must always be connected to protective earth.

2 Device Information Panel

Product name, serial number (SN), product number (PN), and input power requirements.

3 Rear Fan

Rear cooling fan. Take care not to obstruct the opening to assure proper airflow through the generator and prevent overheating.

4 External Variac Control

Via this special interface, the external variac can be controlled by the generator.

5 Auxiliary Connection

Fit the auxiliary connector delivered with the equipment, to close the safety circuit.

It is possible to extend the safety circuit or to connect additional external warning lamps.

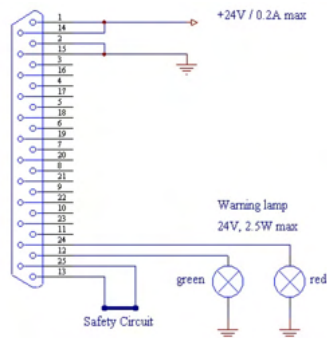

- The green lamp indicates safety circuit open, no test can be started
- The red lamp indicates safety circuit closed, tests can be started

6 Internal Variac Connection

If available, the internal variac (EXT-IMU V) is connected between power input 1 and power input 2. The connection is made with two MC bridges.



DC supply

If the generator is fed with DC, the two bridges must be removed to disconnect the internal variac.

7 EUT Power Input 1

All input plugs and fuses for EUT Power 1 are located in a row. The two 16 A fuses for phase and neutral are located above. Below the fuses are the three power line connections for the EUT power supply.



DC supply

The Module EXT-IMU D or EXT-IMU P must be fitted for dc applications.



For continued fire protection, replace fuse only with fuse of the specified type and rating. Refer servicing to qualified personnel. Disconnect power cord before replacing fuse.

8 EUT Power Input 2

Input for the power level during interruption. When an external source, for example an external variac or an external ac/dc source (PS3), is used, the source must be connected to these inputs.



DC supply

The Module EXT-IMU D or EXT-IMU P must be fitted for dc applications.

9 RS485 Interfaces

Interfaces to connect additional equipment that is controlled directly from the test equipment.

10 USB Port

Connect a USB memory stick to copy files (setups, protocols, error logs) from the generator. The USB interface is also used to update the internal firmware.

11 Ethernet Interface

Remote control using TEMA3000 software via a common Ethernet interface.

12 BNC Inputs/Outputs

Two freely programmable BNC connectors.

Please refer to the chapter Connectors for additional information.

4 Software User Interface

4.1 Home Screen

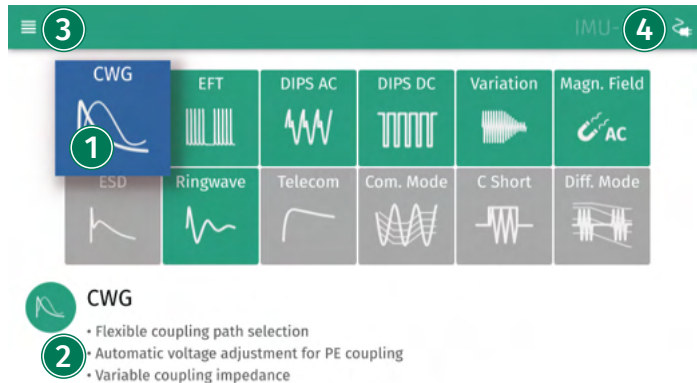

1 Test Selection

The main window shows all tests available on the equipment. The preselected test is indicated with a blue icon. A green icon indicates that this test is available on your generator. A gray icon indicates that this test is not currently available on your generator. Scroll through the tests with the rotary knob or select one directly on the touch screen. If an unavailable test is selected, a message will be displayed about the modules required for this test but not currently available in your generator.



Not all tests are available all the time. Availability depends on hardware configuration. To simplify the menu structure, tests that are unavailable can be removed from the configuration:

≡ (Options Menu) -> Settings -> Settings -> Home Screen

2 Test Description

A short description is included with each test type.

3 Options Menu

In the top-left corner an Options Menu ≡ (Options Menu) is available. It is an overlay menu giving access to equipment and configuration settings. This menu is always available.

4 Quick Power Menu

In the top-right corner a Quick Power Menu is available. It activates an overlay menu on the right side, for direct access to the power control.

4.2 Options Menu

Select ≡ (Options Menu), to enter the options menu. This menu allows access to all test-independent features of your generator.

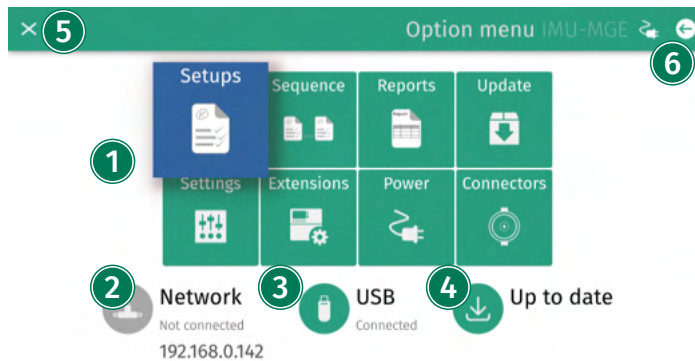

- 1 Utilities**

The options menu includes the various setting options, which are explained in more detail later in this chapter.
- 2 Network**

Indicates if the generator is connected to a network, via the ethernet connector on the rear panel of the generator.
- 3 USB**

Indicates if a USB key is plugged in and recognized by the generator. The USB key can be used to update the generator software and save/load test reports or setups.
- 4 Up to date**

Indicates that the generator software is up-to-date. If the generator is connected to a network with internet access it will automatically look for available updates from EMC PARTNER.
- 5 Exit**

The x-button in the top-left corner can be used to exit the options menu.
- 6 Back**

The arrow-button in the top-right corner can be used to navigate back through the user interface.

4.2.1 Setups

Select ≡ (Options Menu) → Setups, to enter the setups menu.

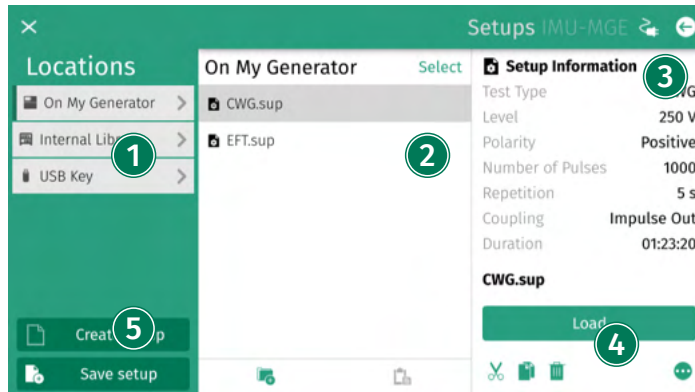

1 Root Directory

Select the location where setups are to be displayed and edited. Choose between the EMCP Library with predefined setups, the user defined internal library or setups on the USB stick.



Changed or deleted files inside the built-in EMCP Library will be restored at the next generator startup.

2 Saved Setups

All saved setups are listed here. The files can be organized in folders and subfolders.

3 Preview

Preview with the most important key data of the selected setups.

4 Actions

In addition to loading the stored setup to configure the generator, the files can be further processed in various ways. The setup can be deleted, renamed, copied and moved. It is also possible to save it directly to the USB stick.



Single setup files are copied to a USB memory stick by selecting the file and choosing copy to USB from the menu. To copy multiple setup files, first push select and mark multiple files. When all files to be copied are marked, press copy to USB as normal.

5 Save Current Setup

The currently configured test will be saved.

4.2.2 Sequence

Select ≡ (Options Menu) → Sequence, to enter the sequence menu.

You can link up to 15 tests, saved internally to run concurrently.

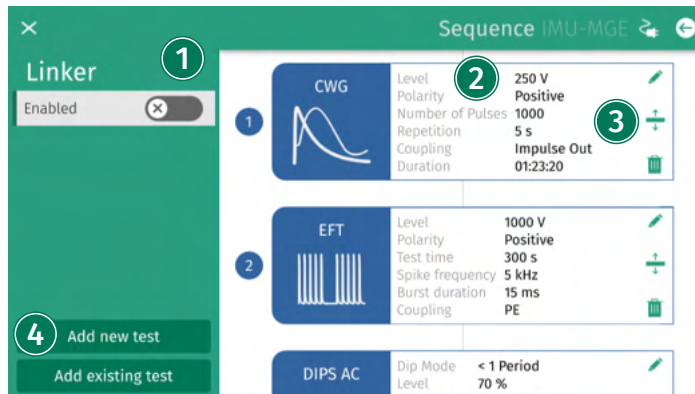

1 Activate

If checked, the setup linker is activated. Press run to start the linked tests.

2 Preview

The individual tests in the sequence are shown with the most important parameters.

3 Edit, Delete, Modify

Edit a single test or delete it completely. Setups are stored as a copy in the setup linker. Any change of parameters or complete deletion has no effect on the source file in the library. The sequence can be changed using Drag & Drop.

4 Action

Existing setups can be added into the sequence from the library or a new setup can be created directly.



A linked sequence cannot be saved internally. TEMA3000 Software provides a complete sequence generation package including DSO integration and other applications.

4.2.3 Reports

Select ≡ (Options Menu) → Reports, to enter the reports menu.

A report containing test parameters and results can be saved in the equipment. Additional information about the EUT and environmental conditions can be added.

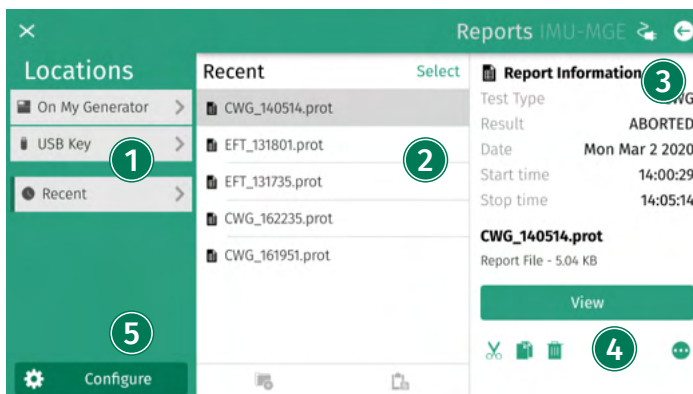

1 Root Directory

Select the location where reports are to be displayed and edited. The last 15 reports are displayed under Recent. This is also the case if the creation of the reports is switched off.

2 Saved Protocols

All saved protocols are listed here. The files can be organized in folders and subfolders.

3 Preview

Preview with the most important key data of the selected report.

4 Actions

In addition to displaying directly on the generator, the reports can be further processed in various ways. The report can be deleted, renamed, copied and moved. It is also possible to save it directly to the USB stick in various formats (PDF, HTML, CVG).



Single protocol files are copied to a USB memory stick by selecting the file and choosing copy to USB from the menu. To copy multiple protocol files, first push select and mark multiple files. When all files to be copied are marked, press copy to USB as normal.

5 Configure

Basic settings for automatic report generation such as storage structure and naming. The default directory structure creates sub directories in the format <year>/<month>/<day>. Additional information about the EUT and the test environment can also be stored. This information is automatically added to each protocol.

4.2.4

Update

Select ≡ (Options Menu) -> Update, to enter the update menu.

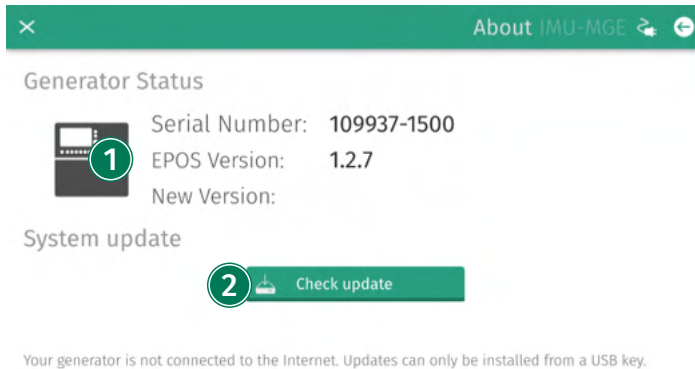

① Generator Status

Generator information is shown, such as the generator product and serial number, the current version of the installed EPOS (EMC PARTNER Operating System) software, as well as a new version (if available).

② Check Update

Forces the generator to check for available updates, an internet connection is necessary.

4.2.5 Settings

Select ≡ (Options Menu) → Settings, to enter the settings menu.

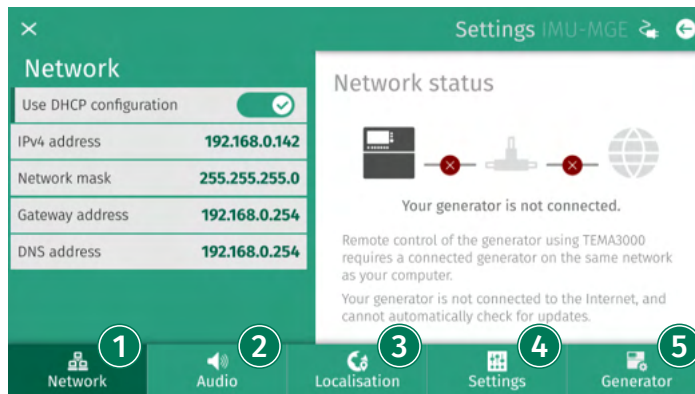

1 Ethernet

Depending on the network capability, the TCP/IP address information for the equipment can be obtained in different ways. If the network supports dynamic TCP/IP configuration using the Dynamic Host Configuration Protocol (DHCP), all address information can be assigned automatically. If the network does not support DHCP, or if the equipment is set to use alternate TCP/IP configuration, the address must be set manually. By default, the equipment is configured to use a manual address.



Risk of network errors

Connection errors can affect the entire network. If the network does not support DHCP, or dynamic TCP/IP configuration is disabled, assign a valid address information before connecting the equipment to the LAN. Contact the local network administrator to obtain a valid IP address.

2 Audio

Volume and type of the different audio messages

3 Localisation

Set equipment time and date, and the required format. This information will be included in the test report and file data.



The user interface is available in different languages. English (Default), German, French, Spanish, Italian, Chinese (Traditional), Chinese (Simplified), and Russian. Additional languages can be provided on request. Please contact EMC PARTNER. All translations are made to the best of our knowledge and abilities, however, we cannot guarantee the correctness of all translations.

4 Settings

Settings for the general behavior of the generator:

- Generator can stop as soon as the EUT failed.
- The generator can perform different tests from the setup linker.
- During a running test changed parameters can be reset when the test is over.
- The direction of the input knob can be inverted.

- Unavailable tests due to missing hardware can completely be removed (instead as being indicated with a gray icon).
- Units for the internal temperature sensor can be selected between Celcius (°C), Fahrenheit (°F) and Kelvin (K). This information is included in the test protocols.

5 Generator

Perform a factory reset or copy service data to the USB drive.

4.2.6

Extensions

Select ≡ (Options Menu) -> Extensions, to enter the extensions menu.

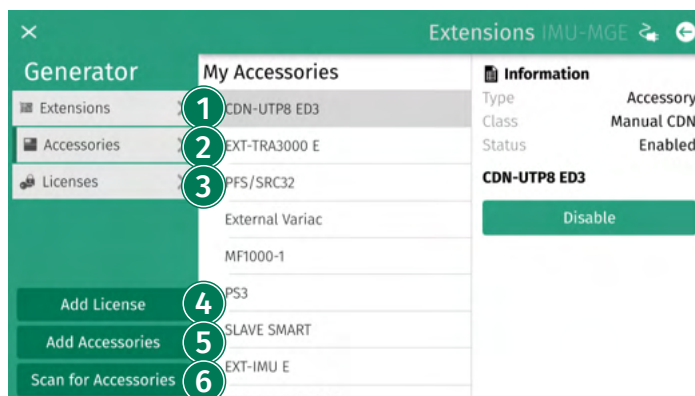

1 Extensions

Shows all internal and external connected extensions. Only extensions which have an active communication with the generator are displayed.

2 Accessories

Listing of all actually available external accessories. The configuration with the actually available external accessories has to be done only once. For a better overview the user interface is adapted to the existing equipment. This adaptation is done automatically based on this configuration.

3 Licenses

Lists all licenses for software options.

4 Add License

Allows adding a new license. Selecting "Add License" opens an on-screen keyboard where you can enter the license key for the software option you have purchased from EMC PARTNER.

5 Add Accessories

Missing accessories can be added manually with "Add Accessories". To find the desired entry faster, the external accessories are grouped into several categories.

6 Scan for Accessories

External accessories that have active communication with the generator via the RS485 bus can be automatically detected and added with a scan.



A scan for newly connected devices is also performed automatically each time the generator is started.

4.2.7

Power



The Power menu is only available on generators with an EUT power input.

Select ≡ (Options Menu) → Power, to enter the power menu.

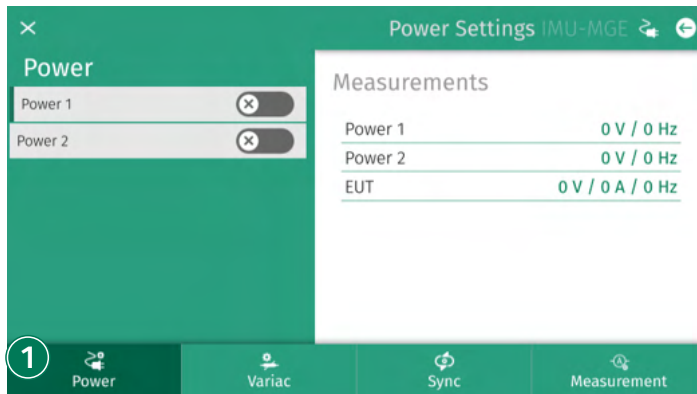
**1 Select**

On the bottom of the screen you can select between one of the following menu items:

- Power
- Variac
- PS3
- Sync
- Measurement



Depending on your generator settings, not all menu items will be available or shown.

A more detailed description of the individual menu items is given in the chapter "EUT Power".

4.2.8 Connectors

Select ≡ (Options Menu) → Connectors, to enter the connectors menu.

There are 4 BNC connectors on the front panel and 2 on the rear panel. The two on the rear panel can always be freely programmed as inputs or outputs. Of the 4 connectors on the front panel, those which are not used as outputs of internal measurements are freely configurable.

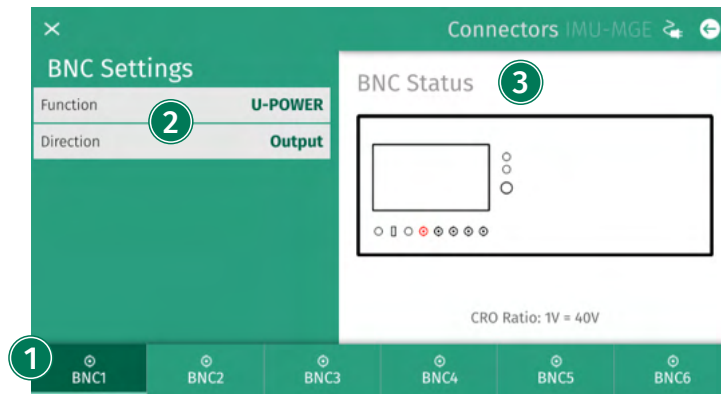

1 BNC Connectors

Select between the six BNC connectors on the generator: BNC1-BNC4 are located on the generator front panel, BNC5 and BNC6 are located on the generator rear panel.

2 BNC Settings

If it is a fixed measurement output, the designation is given. Otherwise, individual programming is possible. They can be programmed to be either inputs or outputs, with active-high or active-low characteristic. Additionally the debounce time can be set freely. They can be programmed with any one of the following functions:

- No Function
- Trigger Input (Input)
- Emergency Stop (Input)
- EUT Fail (Input)
- EUT Mark (Input)
- Running State (Output)
- Safety Circuit State (Output)
- Start Test (Input)
- Stop Test (Input)



Block diagram of the interface

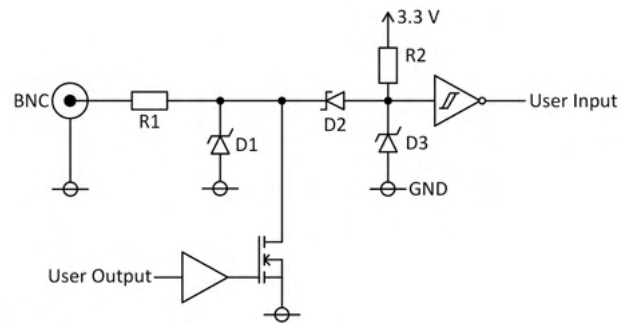

The value of the resistor R1 is 10 Ohm, and the value of R2 is 1kOhm. D1 is a 27V TVS-diode, D2 is a fast Schottky diode, and D3 is a 3.3V TVS-diode.

The output functions as open drain output. Maximum 24 volts for both input and output configuration. Detailed information is given in the technical data

3 BNC Status

Provides additional information on the status of the selected connector.

4.3 Setting up and Running a Test

The same process is used to program the generator for different tests. In the first step, the parameters should be set according to the requirements of the test.

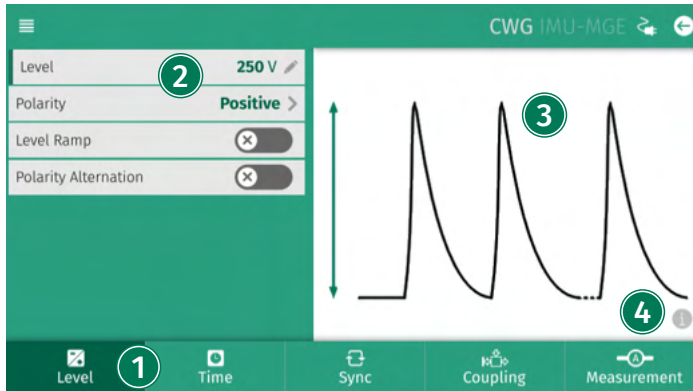

1 Main Category

For quick access, categories at the bottom of the display contain groups of relevant parameters. Select a category using the touch panel or the rotary knob.

2 Parameter List

All parameters from a selected category are shown on a single screen. Click on a parameter to edit the value.



Press and turn the rotary knob at the same time for a quick parameter change.

All parameters are checked for validity during the entry process. If necessary (for example test level too high), the system automatically corrects the value. Corrected values are indicated by a red background.

The system also checks for inconsistencies with other parameters and, where necessary, makes an adjustment. It is not possible to create a test containing invalid parameters.

3 Parameter Image

Individual images clarify the effect of each parameter.

4 Parameter Help

For each parameter, an additional help text is provided directly on the generator. Press the info button to open the help text in a popup window.



Starting a test by pressing the run button on the front panel, changes the display to the run view.

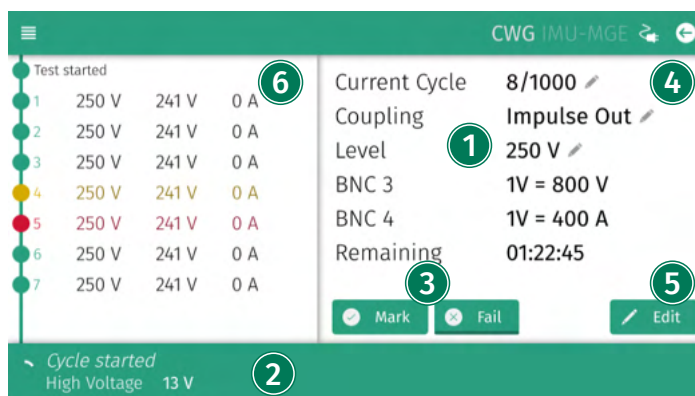

- 1 Information Area**
Indicates the most important information about a running test.
- 2 Status Bar**
Provides information about the current event.
- 3 Mark / Fail**
Mark or Fail add this information at the current test position. This information will be included in the report.
- 4 Quick Parameter Change**
All parameters that are marked with a pencil symbol in the information area can be edited with a single click on the parameter during the test.
- 5 Edit Parameter**
Many parameters can be edited during an ongoing test. A click on Edit shows all parameters. Modifiable parameters are marked, unchangeable ones are shown with a short animation when clicked. Depending on the test type, parameter change will take place with the next cycle or after a few seconds. Changed values are highlighted for a few seconds in the information area.
- 6 Live Report**
At this point information about the entire test is displayed. The content depends on the particular test and could include readings, changed parameters or information about warnings. If the test was marked during the run, this is indicated by a yellow marking. If it was highlighted with fail, an entry is made in red.



Pause and Resume a Test

Most tests can be paused with a click on the start/pause button. Another click on the Start/Pause button resumes the test at the current position.



During the pause, only the disturbance source is interrupted. A possible EUT voltage will not be switched off. Only a stopped test and an open safety circuit (pressed emergency button) guarantees a safe operation on the connected device.

After the test time has expired or if the test is stopped manually, the complete report is displayed. It is possible to save the report in the desired format (PDF, HTML, CSV) directly to the USB stick.



Under ≡ (Options Menu) -> Reports -> Configure you can set that the protocol is automatically saved in the desired format.

5 EUT Power

Two different inputs for powering EUTs through the generator up to the maximal current of the internal CDN are on the rear side of the generator, power 1 (PWR1) and power 2 (PWR2). Depending on the test, both PWR1 and PWR2, only PWR1 or none of them is used. See the chapter "Testsetups - General" and the chapters on the individual immunity tests for details. The following chapter describes the most common possibilities to connect a power source to the generator and to control the EUT power as long as it is not controlled by the test itself.

The four different options available from EMC PARTNER considered here are:

- Internal Variac EXT-IMU-V
- External Variac VAR-EXT1000
- Fixed Tapped Transformer SRC16-1P
- Programmable Power Supply PS3

More detailed information on the four devices can be found in the chapters "???" and "??".

For tests that involve EUT currents exceeding the maximal current of the internal CDN, other options are available and are described in the appropriate chapters.



If you use your own power supply it may be equipped with a fault current protective switch. This may release when connecting the generator due to the inrush current of the filter capacitor of the internal CDN. For testing with the generator use a power supply without a fault current protective switch or connect an insulation transformer between the power supply and the generator. In this case, one secondary output terminal of the transformer must be grounded.

5.1 Connections

5.1.1 Internal Variac EXT-IMU V

To supply an EUT with currents through the internal variac and CDN, the connections must be made as shown in the following figure: Note that only currents up to the maximal voltage and current rating of the EXT-IMU-V as specified in "???" can be supplied in this way



You can supply your EUT with currents up to the maximal current rating of the generator internal CDN, as specified in "??". Simply feed the the power from your power outlet directly through the internal CDN of the IMU-MGS or IMU-MGE generator.

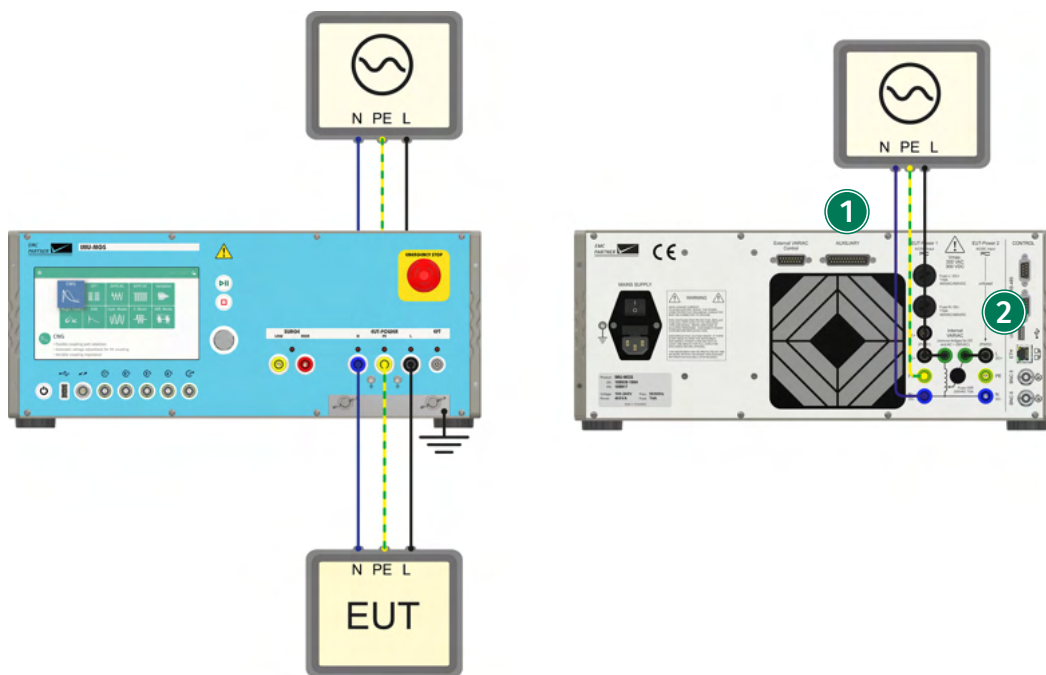

① Power Input

Line, Neutral and Earth is connected to the fused PWR1 input on the rear panel of your generator.

② Bridges

The bridge on the left side connects the internal variac with the public power supply on the primary side. The second bridge on the right side connects the secondary side of the variac to the EUT PWR2 input.

5.1.2 External Variac VAR-EXT1000

The external variac VAR-EXT1000 is available from EMC PARTNER. It can be used to supply EUTs up to the maximal voltage and current ratings as defined in "??".

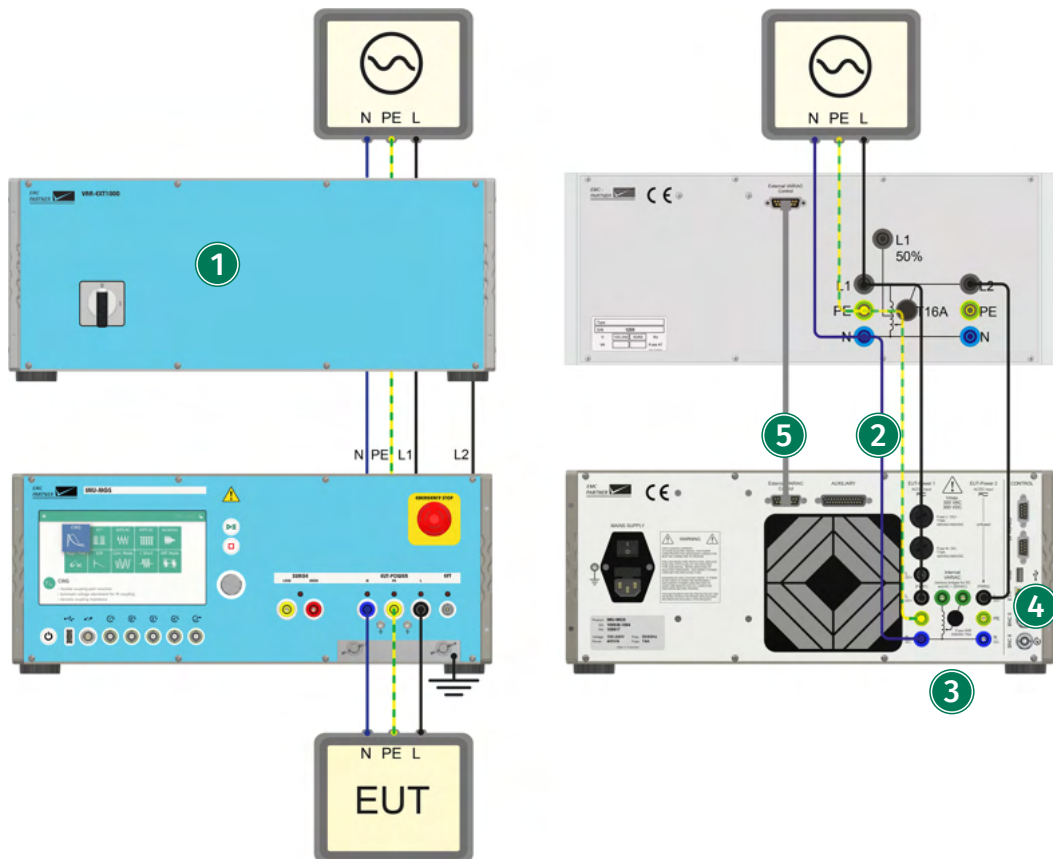

- ① **VAR-EXT1000**
The external variac VAR-EXT1000 replaces the internal variac EXT-IMU-V.
- ② **Power Input**
Line, Neutral and Earth is connected to the input of the external variac and to the fused PWR1 input on the rear panel of the generator.
- ③ **Bridges**
The 2 bridges of the internal variac must be removed.
- ④ **Power 2**
Connect the output on the rear panel of the VAR-EXT1000 with the PWR2 input on the rear panel of the generator.
- ⑤ **Control Connection**
Connect the control cable between "External Variac Control" on the generator rear panel and "Variac Control" on the VAR-EXT1000 rear panel.

5.1.3 Fixed Tapped Transformer SRC16-1P

The SRC16-1P is a fixed tapped transformer with maximal voltage and current ratings as defined in "???" and fixed voltage outputs at 80%, 70% and 40%.

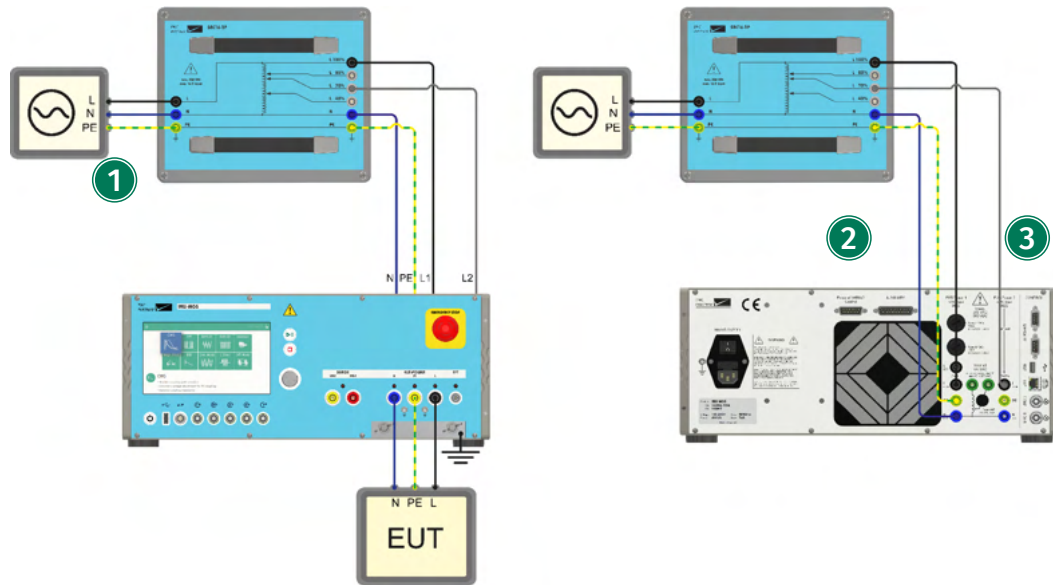

- ① **Power Input**
Line, Neutral and Earth is connected to the inputs L, N, and PE of the SRC16-1P.
- ② **SRC16-1P Output**
Line (100%), Neutral (N) and Earth (PE) from the output of the SRC16-1P are connected to the PWR1 inputs on the generator rear panel.
- ③ **SRC16-1P Tapped Output**
The tapped voltage L 80%, L 70%, or L 40% is connected to the PWR2 Line input on the generator rear panel.

5.1.4 Programmable Power Supply PS3

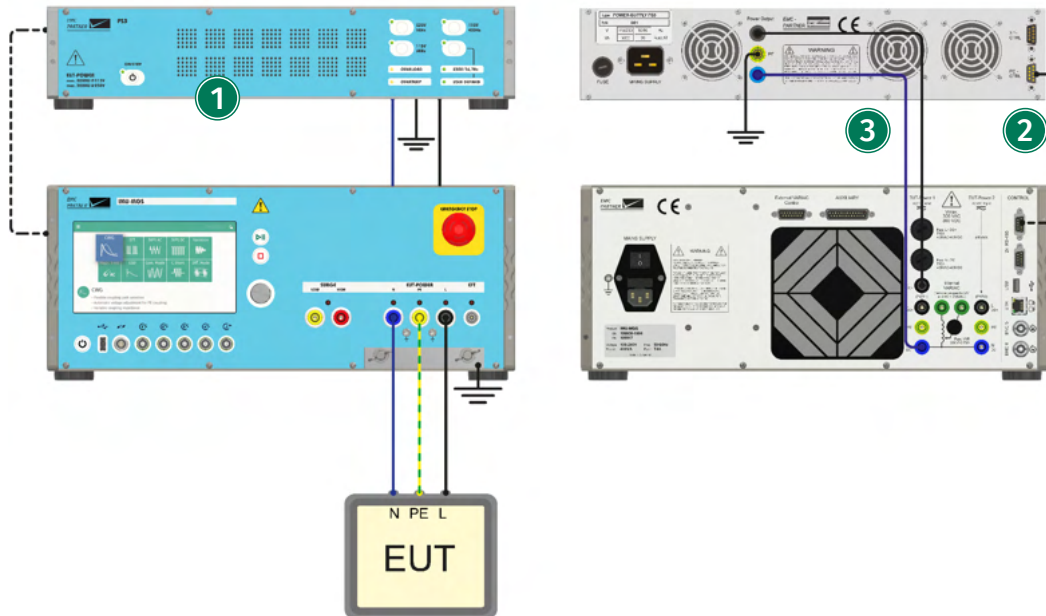

- 1 PS3**
The PS3 programmable power supply is powered through the mains plug on the rear panel to the power grid.
- 2 RS485-RS232 Adapter**
An RS485-RS232 Adapter is used to connect the RS232 control on the PS3 rear panel to the RS485 control on the generator rear panel.
- 3 PS3 Power Outputs**
The Line (L), Neutral (N) and Earth (PE) outputs on the PS3 rear panel can be connected to the generator rear panel as follows

 - PWR1 (L,N,PE) inputs for AC applications
 - PWR2 (L,N,PE) inputs for AC applications, e.g. when two PS3 are used
 - DC+ and DC- inputs for DC applications



DC Mode Before a dc supply for the EUT can be used the two bridges of the internal variac must be removed and a possible external variac or transformer must be disconnected. Otherwise, the variac or transformer will be heated and destroyed.



If two independent power sources are used in ac mode, they must be synchronized!

5.2 Software Control

For some tests, the power to the EUT is controlled by the test itself, this is the case for the following tests:

- Voltage Variation
- AC Magnetic Field
- AC DIPS
- DC DIPS
- Common Mode

When none of these tests are running, the power to the EUT can be controlled by the user, through the power menu in the generator software interface.

Go to ≡ (Options Menu) in the top-left corner of the display and select Power.

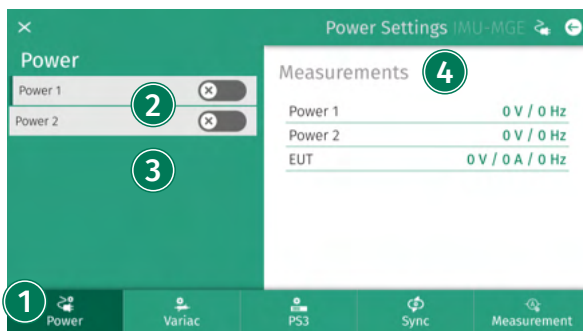

- 1 **Menu**
Power menu tab.
- 2 **Power**
Switch PWR1 or PWR2 on or off.
- 3 **Switch external PFS**
If this option is enabled, the power control signal is routed to an external device.
- 4 **Measurements**
Provides voltage, current and frequency measurements on the individual power sources.

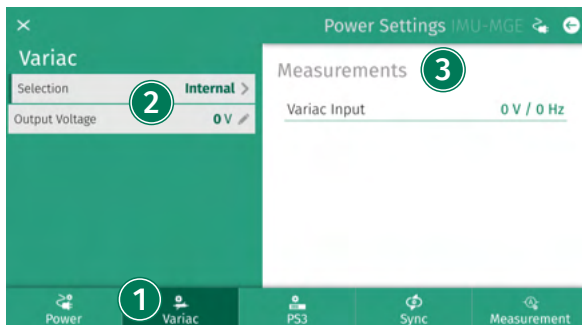

- 1 **Menu**
Variac menu tab

2 Variac Settings

Select between the internal variac (EXT-IMU V) or an external variac (VAR-EXT1000) and set the output voltage.

3 Measurements

Provides voltage and frequency measurements on the variac input.



1 Menu

PS3 menu tab

2 PS3 Settings

Set the serial number of the connected PS3 and the output voltage. Pre-programmed output voltages are 230 V/50 Hz and 115 V/60 Hz, however also customized AC or DC voltages can be programmed, within the technical specifications of the PS3 power supply.

3 PS3 Status

Additional information on the connection status of the PS3 is provided.

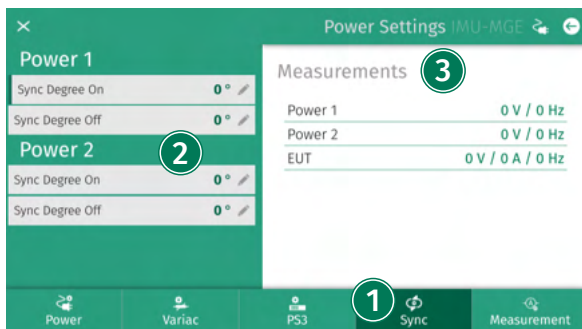

1 Menu

Synchronization menu tab

2 Synchronization

Set the phase angles for power switching on PWR1 and PWR2 individually.

3 Measurements

Provides voltage, current, and frequency measurements on PWR1, PWR2 and EUT power.



EXT-IMU D or EXT-IMU P must be installed for synchronized power switching. Otherwise, the power switching will not be synchronized.

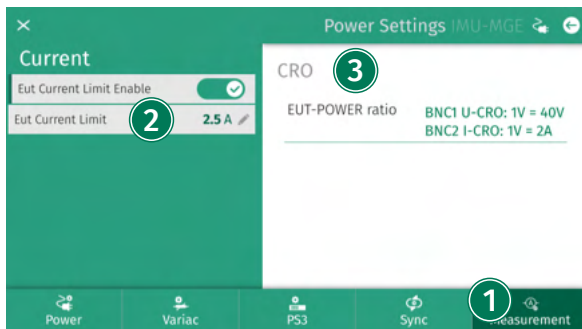

① Menu

Measurement menu tab

② Current Limit

An EUT current limiter can be enabled. The generator can be programmed with any value up to 16 A. If the EUT current exceeds this limit, the generator will stop the test and switch off the power.

③ CRO Settings

Information on the measurement ratios of the power measurements are provided. The measurements can be accessed via BNC1-BNC4 on the generator front panel.

6 Testsetups - General

The following chapters provide detailed information on the test setups for testing with the IMU-MGS and IMU-MGE generators. Additionally some system calibration and verification setups are shown.



Additional information for calibration is also available in the calibration report of your generator.



The hardware characteristics of the IMU-MGE and IMU-MGS generators are very similar, they have the same user interface, as well as inputs and outputs. The only (external) difference between the IMU-MGS and the IMU-MGE are the mechanical size. Therefore in this chapter, all test setups are shown with the IMU-MGS generators, the setups for the IMU-MGE are identical (unless explicitly stated otherwise).

7 Tests as per IEC 61000-4-2: ESD

This chapter provides information on generator calibration and verification as well as on testing setups for immunity tests according to the latest edition of IEC 61000-4-2: "Testing and measurement techniques - Electrostatic discharge immunity test".

7.1 Hardware Description

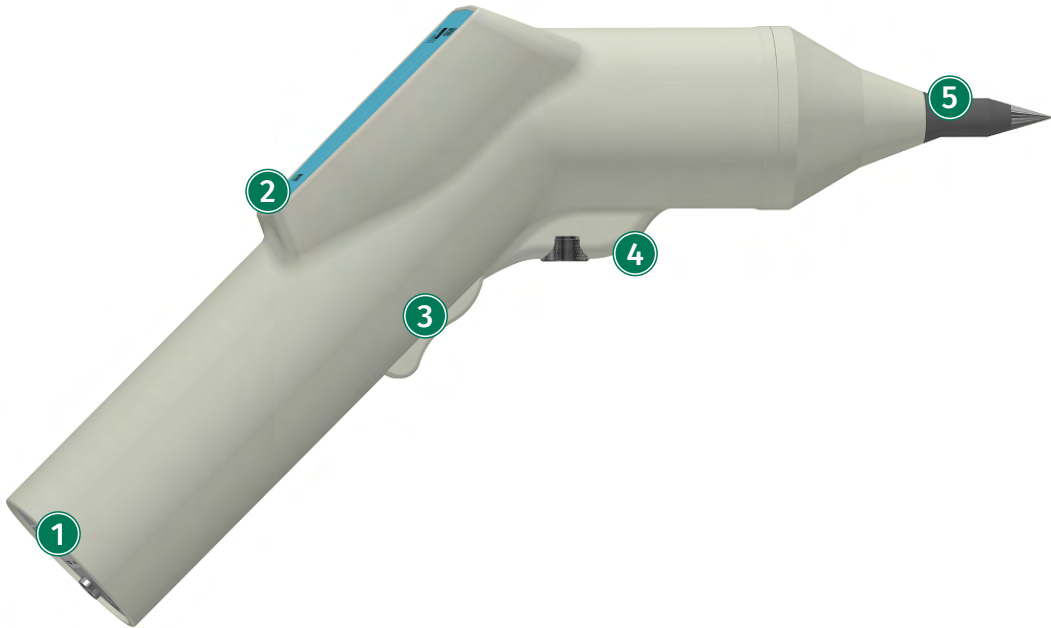

- 1 Connectors**
AUXILIARY connector for connection of the EXT-IMU-E to the IMU-MGS or IMU-MGE generators.
PE connector to connect the EARTH-CABLE.
- 2 Status LED**
After connection of the EXT-IMU E to the IMU-MGS or IMU-MGE generator, the LED flashes 3 times and two beeps will sound, indicating that EXT-IMU-E has been recognized by the generator. A third beep indicates that EXT-IMU-E is ready for operation.
- 3 Trigger Button**
The trigger button allows release of an electrostatic discharge at the tip of the EXT-IMU E.
- 4 Mounting Screw**
A mounting screw allows fast and easy fixing of the EXT-IMU E to the ESD-STAND ED2.
- 5 Tip**
Two different tips (electrodes) are available, a pointy tip for contact discharge testing and a rounded tip for air discharge testing.

7.2 Immunity Tests



When using EXT-IMU E, ensure the is always connected to the ground plane and that the ground plane is connected to the generator ground. Otherwise EXT-IMU E will not be recognized by the generator.



Only test setups for table-top equipment are shown here. For further details and information on other test setups, e.g. floor-standing equipment, wall- or ceiling-mounted equipment, please refer to the latest edition of IEC 61000-4-2.

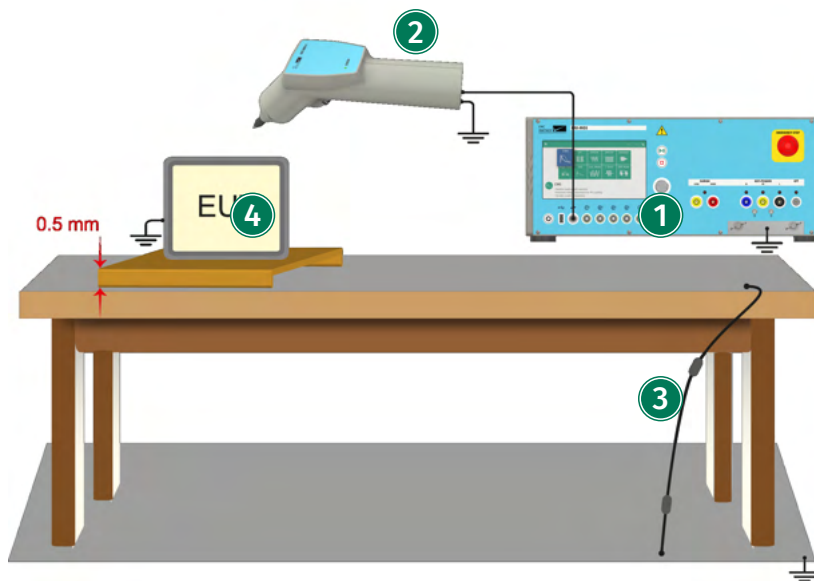

IMU-MGS or IMU-MGE - EXT-IMU E

1 Generator

On your IMU-MGS or IMU-MGE generator select the "ESD" immunity test and set the test parameters, e.g. Level, Polarity, Timing, Trigger Mode, etc. according to your needs. Under (Options) set the "Discharge Mode" to Air.

2 EXT-IMU E

Connect the EXT-IMU E to your generator via the AUXILIARY connector on the bottom of the EXT-IMU E and on the front panel of the generator. Connect the EXT-IMU E to ground via the flat cable with yellow connectors. Equip the EXT-IMU E with the air discharge tip.

3 EARTH CABLE

A cable with two 470 kOhm bleeding resistors, i.e. EARTH CABLE, needs to be used to connect the conductive table-top to the reference ground plane in your test setup.

4 Equipment Under Test (EUT)

The equipment under test (EUT), in this setup a table-top equipment, is placed on top of a table with a conductive surface, but needs to be isolated from the surface.

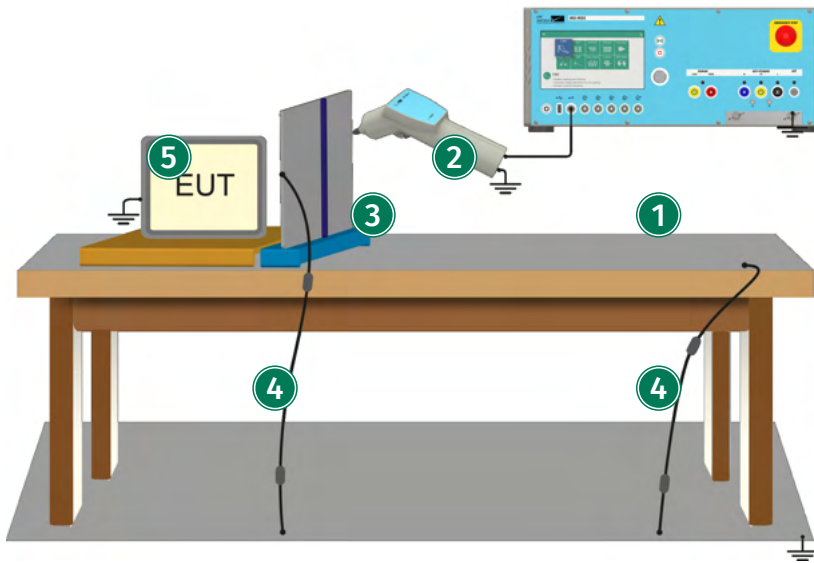

IMU-MGS or IMU-MGE - EXT-IMU E - ESD-VCP50

- ① **Generator**
On your IMU-MGS or IMU-MGE generator select the "ESD" immunity test and set the test parameters, e.g. Level, Polarity, Timing, Trigger Mode, etc. according to your needs. Under (Options) set the "Discharge Mode" to Contact.
- ② **EXT-IMU E**
Connect the EXT-IMU E to your generator via the AUXILIARY connector on the bottom of the EXT-IMU E and on the front panel of the generator. Connect the EXT-IMU E to ground via the flat cable with yellow connectors. Equip the EXT-IMU E with the contact discharge tip.
- ③ **Vertical Coupling Plate ESD-VCP50**
A vertical coupling plate (VCP), i.e. ESD-VCP50, is used to investigate effects of indirect ESD discharges on the EUT. Place the tip of EXT-IMU E in contact with the VCP.
- ④ **EARTH CABLE**
A cable with two 470 kOhm bleeding resistors, i.e. EARTH CABLE, needs to be used to connect the conductive table-top to the reference ground plane in your test setup. A second EARTH CABLE needs to be used to connect the VCP to the reference ground plane of your setup.
- ⑤ **Equipment Under Test (EUT)**
The equipment under test (EUT), in this setup a table-top equipment, is placed on top of a table with a conductive surface, but needs to be isolated from the surface.

7.3 Calibration



When using the EXT-IMU E, ensure the EARTH CABLE is always connected to the ground plane and that the ground plane is connected to the generator ground. Otherwise EXT-IMU E will not be recognized by the generator.

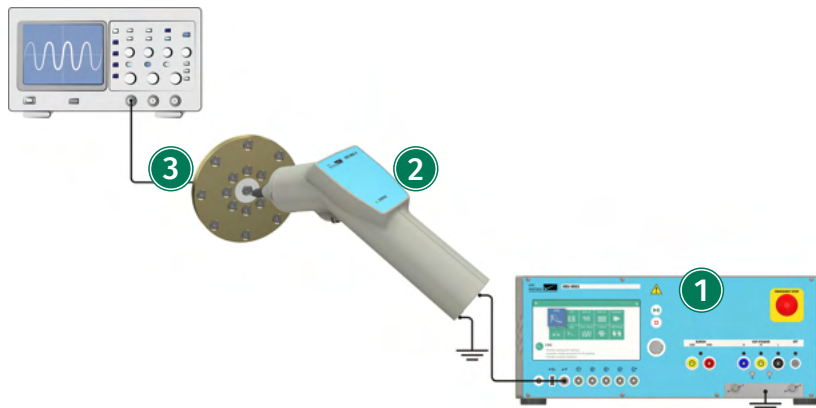

IMU-MGS or IMU-MGE - EXT-IMU E - ESD-TARGET2

1 Generator

On your IMU-MGS or IMU-MGE generator select the "ESD" immunity test and set the test parameters, e.g. Level, Polarity, Timing, Trigger Mode, etc. according to your needs. Under (Options) set the "Discharge Mode" to Contact. The generator needs to be connected to ground.

2 EXT-IMU E

Connect the EXT-IMU E to your generator via the AUXILIARY connector on the bottom of the EXT-IMU E and on the front panel of the generator. Connect the EXT-IMU E to ground via the flat cable with yellow connectors. Equip the EXT-IMU E with the contact discharge tip.

3 Calibration Target ESD-TARGET2

ESD-TARGET 2 can be directly connected to a 50 Ohm port of your oscilloscope. Place the tip of the EXT-IMU E on the center of ESD-TARGET2.



The oscilloscope should have a minimal bandwidth of 2 GHz.



For details on the calibration setup, please refer to the latest edition of IEC 61000-4-2.

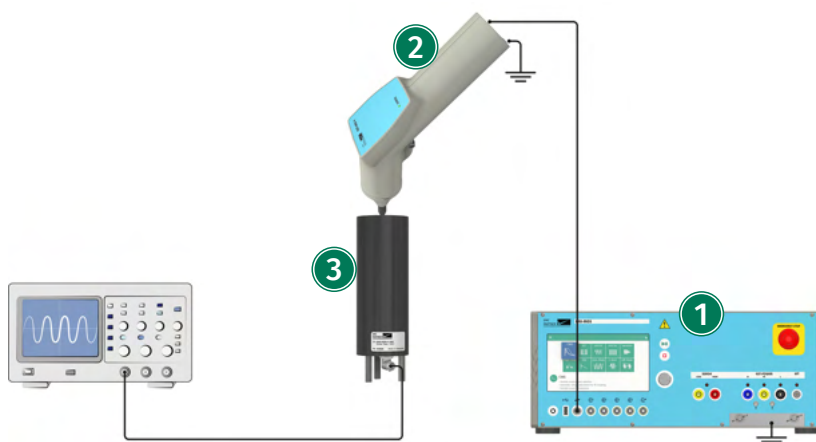

IMU-MGS or IMU-MGE - EXT-IMU E - ESD-VERI-V

① Generator

On your IMU-MGS or IMU-MGE generator select the "ESD" immunity test and set the test parameters, e.g. Level, Polarity, Timing, Trigger Mode, etc. according to your needs. Under (Options) set the "Discharge Mode" to Air.

② EXT-IMU E

Connect the EXT-IMU E to your generator via the AUXILIARY connector on the bottom of the EXT-IMU E and on the front panel of the generator. Connect the EXT-IMU E to ground via the flat cable with yellow connectors. Equip the EXT-IMU E with the air discharge tip.

③ Voltage Verification Device ESD-VERI-V

ESD-VERI-V should be connected to a 1M Ω port of your oscilloscope. Place the EXT-IMU E inside the ESD-VERI-V.

8 Tests as per IEC 61000-4-4: EFT/Burst

This chapter provides information on generator calibration and verification as well as on testing setups for immunity tests according to the latest edition of IEC 61000-4-4: "Testing and measurement techniques - Electrical fast transient/burst immunity test".



To perform this test your IMU-MGS generator must be equipped with one of the following modules:

- EXT-IMU4000 F4
- EXT-IMU4000 F5



To perform this test your IMU-MGE generator must be equipped with one of the following modules:

- EXT-IMU3000 F5
- EXT-IMU3000 F6
- EXT-IMU3000 F7

8.1 Immunity Tests



For coupling on external power lines, e.g. using an external three-phase CDN, or coupling on data lines via external data line CDNs, please refer to the chapters on power line and data line CDNs.

8.1.1 Power Line Coupling with Internal CDN

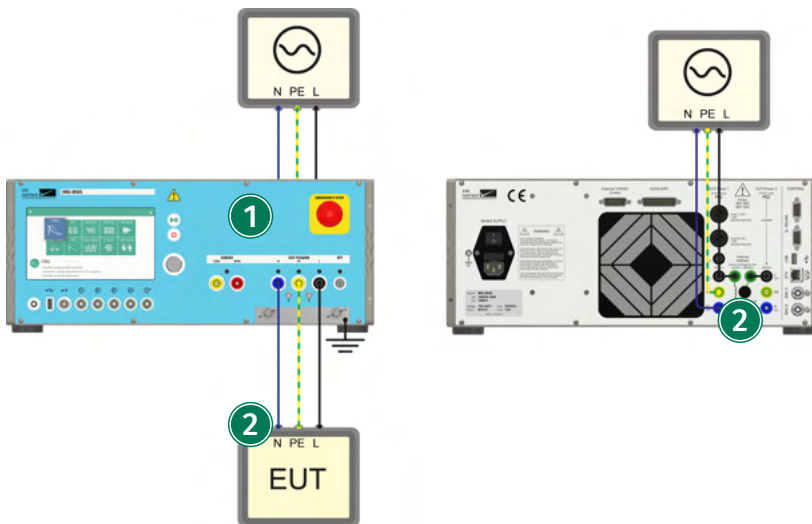

IMU-MGS or IMU-MGE

1 Generator

In the generator menu, select "Internal CDN" as coupling device and the desired coupling path. The generator should be placed directly on the ground plane. The connection between generator and ground plane should be as short as possible.

2 CDN Power Input

Connect Line, Neutral and Earth to the CDN to the public power mains and switch on PWR1 or PWR2. See further information in the section "EUT Power".

3 Equipment Under Test (EUT)

Connect the EUT to the output of the CDN. The EUT shall be placed on a ground reference plane and shall be insulated from it by an insulating support with a thickness of 0.1 m, e.g. the EFT INSULATION.

8.1.2 Coupling with Capacitive Coupling Clamp

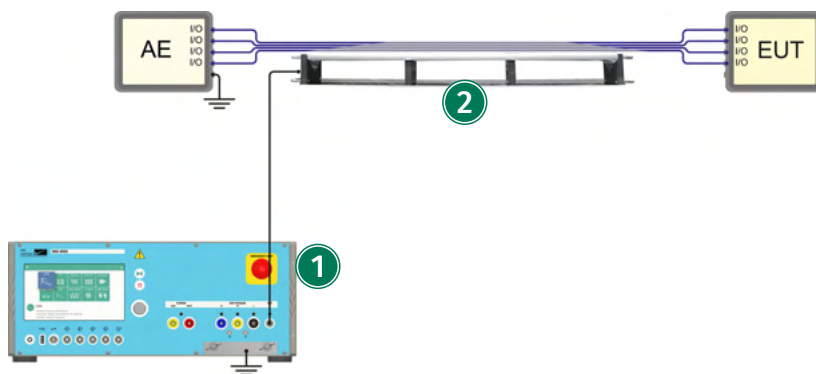

IMU-MGS or IMU-MGE - CN-EFT1000

1 Generator

In the generator menu, select "Direct Out" as coupling device and "Impulse Out" as coupling path. The generator should be placed directly on the ground plane. The connection between generator and ground plane should be as short as possible.

2 Capacitive Coupling Clamp CN-EFT1000

The clamp shall be placed on a ground reference plane. The cables connecting the AE and the EUT are placed on top of the CN-EFT1000, below the cover. The cover should be closed as tightly as possible to provide maximum coupling capacitance between the cable and the clamp.

8.1.3 Differential Mode Testing

EFT differential mode testing can be performed using the CN-BALUN-AC.

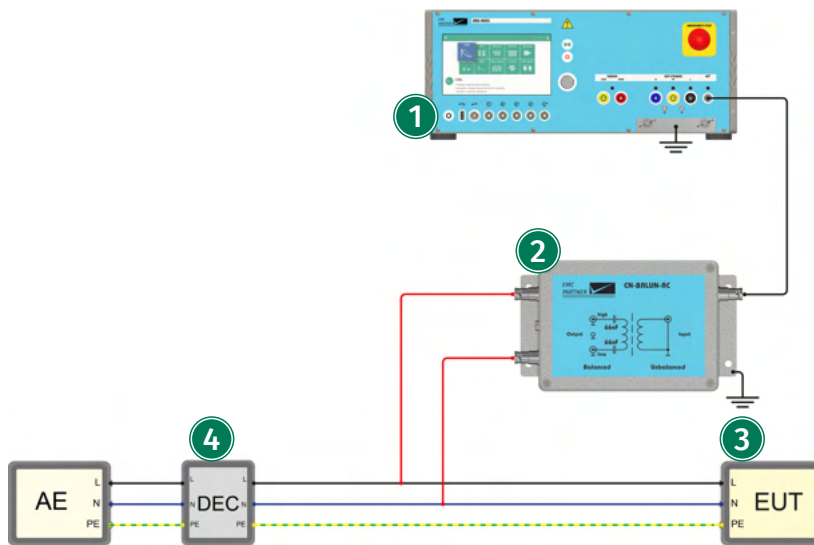

IMU-MGS or IMU-MGE - CN-BALUN-AC

1 Generator

In the generator menu, select Direct Out as coupling device and Impulse Out as coupling path. The generator should be placed directly on the ground plane. The connection between generator and ground plane should be as short as possible.

2 Coupling Network CN-BALUN-AC

The CN-BALUN-AC is designed to apply burst in differential mode. This is not required in IEC 61000-4-2, but in ANSI C37.90. The unbalanced input is connected with a 1 m cable to the generator and the case of the CN-BALUN-AC should be connected to ground, i.e. placed on the ground plane.

3 Equipment Under Test (EUT)

The external connection pair is connected with the balanced output of the CN-BALUN-AC.

4 Decoupling

A decoupling network should be used between the AE and the EUT. The decoupling should be done with decoupling inductors with values greater than 100 μH . The decoupling part of a power line CDN can be used.

8.2 Calibration



Additional information for calibration is also available in the calibration report of each product.

8.2.1 Calibration of the Direct Output

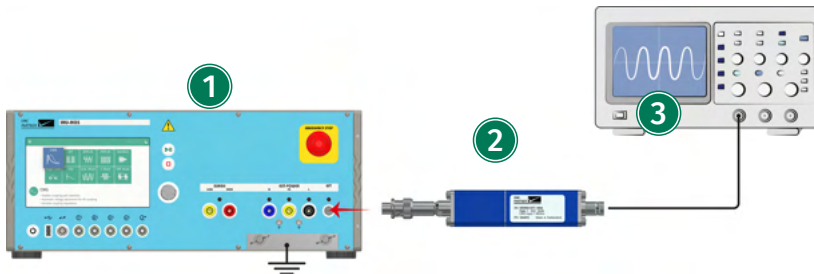

IMU-MGS or IMU-MGE - VERI50 EFT - VERI1K EFT -

1 Generator

The calibration is carried out at the direct output of the generator. The generator should be placed directly on the ground plane. The connection between generator and ground plane should be as short as possible. In the generator test menu, select "Direct Out" as the coupling device and "Impulse Out" as coupling.

2 Measurement Device

Connect either VERI50 EFT or VERI1K EFT to the output. For the direct output calibration, a 50 Ohm and a 1 kOhm termination measurement are required.

3 Oscilloscope

The oscilloscope must have a minimum bandwidth of 400 MHz.

8.2.2 Calibration of the CDN Output

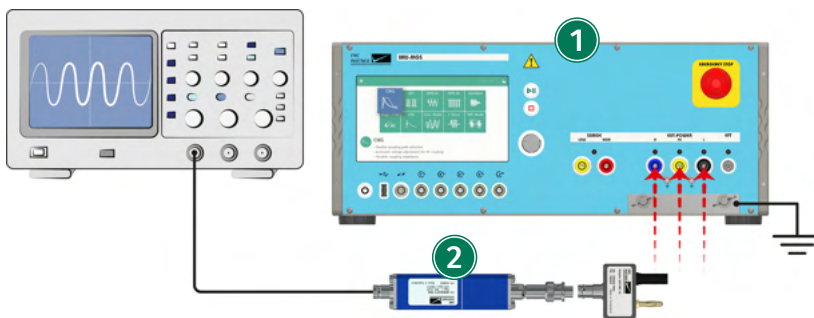

IMU-MGS or IMU-MGE - VERI50 EFT -

1 Generator

For a system calibration including the internal mains CDN, the calibration is carried out at the output of the CDN (EUT Power). The generator should be placed directly on the ground plane. The connection between generator and ground plane should be as short as possible. In the generator test menu, select "Internal CDN" as the coupling device and all three outputs (L1, N, and PE) as coupling. Coupling is set to Common Mode (L1+N+PE to GND) and the signal is measured on each line separately. No power on CDN input.

2 Measurement Device

Connect the VERI50 EFT to the output the CDN (Line, Neutral or PE) which is being calibrated.

For the internal CDN, the 50 Ohm termination is sufficient. To connect the VERI50 EFT to the CDN output an Adapter SHV-MC 32 is required.

8.2.3 Calibration of the Capacitive Coupling Clamp

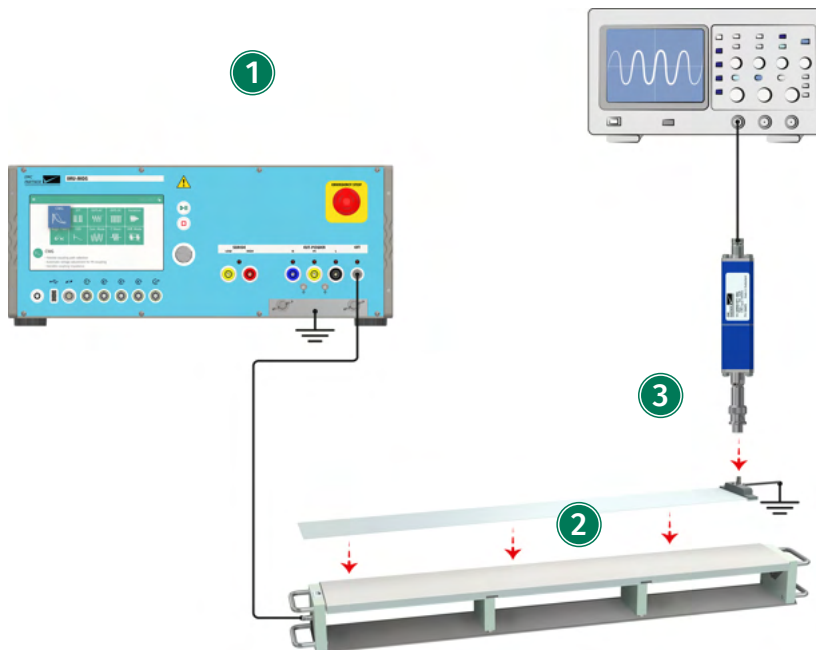

IMU-MGS or IMU-MGE - CN-EFT1000 - VERI-CP-EFT

1 Generator

The generator should be placed directly on the ground plane. The connection between generator and ground plane should be as short as possible. In the generator test menu, select "Direct Out" as the coupling device and "Impulse Out" as coupling.

2 Capacitive Coupling Clamp CN-EFT1000

Place the capacitive coupling clamp CN-EFT1000 on the ground plane and place the VERI-CP-EFT inside, below the cover. The cover should be closed as tightly as possible to provide maximum coupling capacitance between the cable and the clamp.

3 Measurement Device

Connect the VERI-CP-EFT to the oscilloscope via the VERI50 EFT.

9 Tests as per IEC 61000-4-5: Surge

This chapter provides information on generator calibration and verification as well as on testing setups for immunity tests according to the latest edition of IEC 61000-4-5: "Testing and measurement techniques - Surge immunity tests".



To perform this test your IMU-MGS generator must be equipped with one of the following modules:

- EXT-IMU4000 S4
- EXT-IMU4000 S5



To perform this test your IMU-MGE generator must be equipped with one (or more) of the following modules:

- EXT-IMU3000 S6
- EXT-IMU3000 S8
- EXT-IMU3000 T6
- EXT-IMU3000 T8

9.1 Immunity Tests



For coupling on external power lines, e.g. using an external three-phase CDN, or coupling on data lines via external data line CDNs, please refer to the chapters on power line and data line CDNs.

9.1.1 Power Line Coupling with Internal CDN

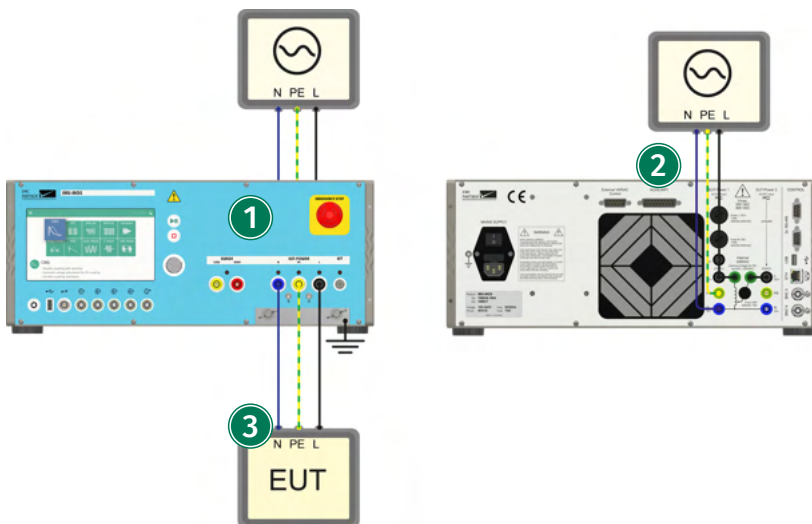

IMU-MGS or IMU-MGE

1 Generator

On your IMU-MGS or IMU-MGE generator select the "CWG" immunity test and set the test parameters according to your needs. Select the (Coupling) menu tab, and set "Device" to internal and "Coupling" to "L1 to N", "L1 to PE", or "N to PE" according to your needs.

2 CDN Power Input

Connect Line, Neutral and Earth on the rear panel of your generator to the public power mains or your voltage source and switch on PWR1 or PWR2. For further information see the section "EUT Power".

3 Equipment Under Test (EUT)

Connect the EUT to the output of the internal CDN (EUT-POWER).

9.1.2 Coupling on Shielded I/O Lines

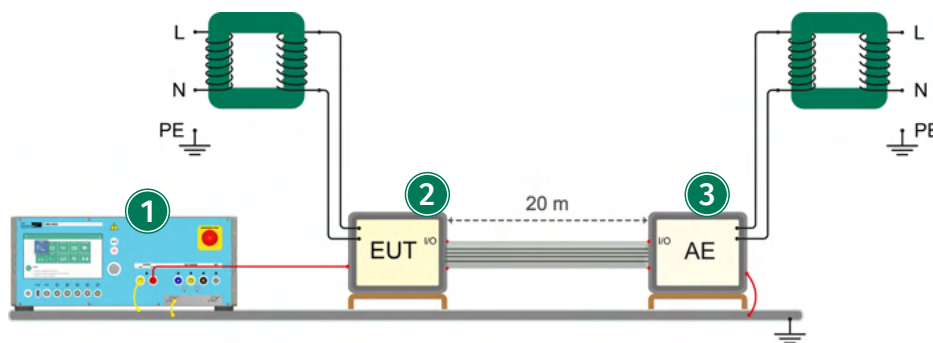

IMU-MGS or IMU-MGE

1 Generator

In the generator menu, select "Internal" as coupling device and "Impulse Out" as coupling path.

Output High is connected to the enclosure of the EUT. Output Low is connected to ground plane.

2 Equipment Under Test (EUT)

The EUT is isolated from ground. All connections to the EUT other than the port under test shall be isolated from ground by safety isolating transformers or a suitable decoupling network.

The preferred length for the connection between EUT and AE is 20 m.

3 Auxiliary Equipment (AE)

The auxiliary equipment (AE) is isolated from ground. All connections to the EUT other than the port under test shall be isolated from ground by a safety isolating transformers or a suitable decoupling network.

The enclosure of the AE is connected to the ground plane.

9.2 Calibration

9.2.1 Calibration of the Direct Output

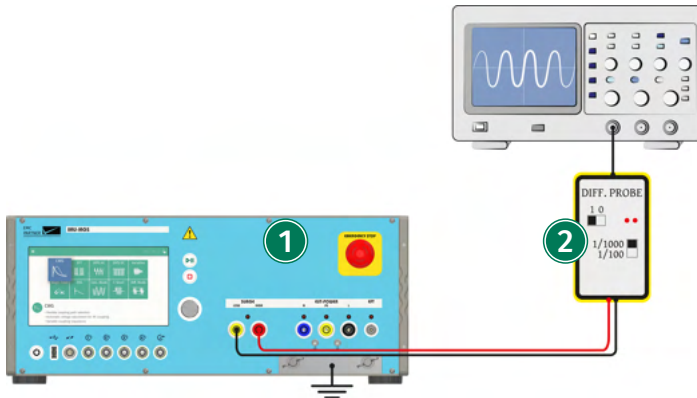

IMU-MGS or IMU-MGE - V-PROBE-SI

1 Generator

On your IMU-MGS or IMU-MGE generator select the "CWG" or "Telecom" immunity test and set the test parameters according to your needs. Select the (Coupling) menu tab, and set "Device" to internal and "Coupling" to Impulse Out.

2 Differential Probe

Connect a differential probe with sufficient specifications, e.g. V-PROBE-SI, to the direct impulse output (Surge - Low and High) of your generator.

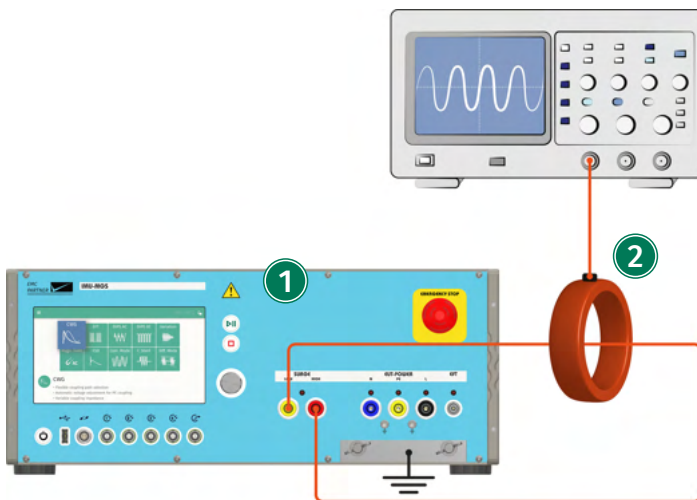

IMU-MGS or IMU-MGE - I-PROBE-P101

1 Generator

On your IMU-MGS or IMU-MGE generator select the "CWG" or "Telecom" immunity test and set the test parameters according to your needs. Select the (Coupling) menu tab, and set "Device" to internal and "Coupling" to Impulse Out.

2 Current Probe

Connect a current probe with sufficient specifications, e.g. I-PROBE-P101, to the direct impulse output (Surge - between Low and High) of your generator.

9.2.2 Calibration of the CDN Output

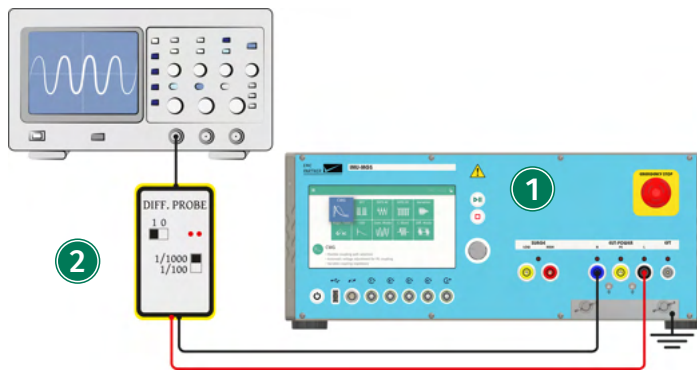

IMU-MGS or IMU-MGE - V-PROBE-SI

1 Generator

On your IMU-MGS or IMU-MGE generator select the "CWG" immunity test and set the test parameters according to your needs. Select the (Coupling) menu tab, and set "Device" to internal and "Coupling" to "L1 to N", "L1 to PE", or "N to PE" according to your needs.

2 Differential Probe

Connect a differential probe with sufficient specifications, e.g. V-PROBE-SI, to the EUT-POWER output, between the selected outputs, i.e. "L1 to N", "L1 to PE", or "N to PE".

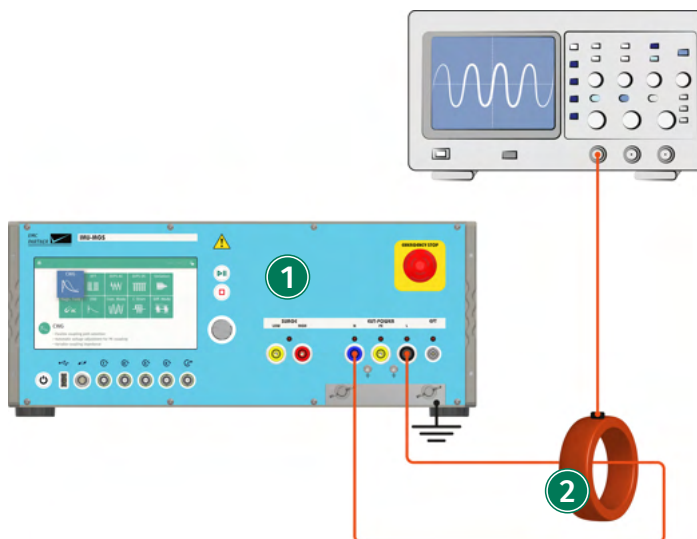

IMU-MGS or IMU-MGE - I-PROBE-P101

① Generator

On your IMU-MGS or IMU-MGE generator select the "CWG" immunity test and set the test parameters according to your needs. Select the (Coupling) menu tab, and set "Device" to internal and "Coupling" to "L1 to N", "L1 to PE", or "N to PE" according to your needs.

② Current Probe

Connect a current probe with sufficient specifications, e.g. I-PROBE-P101, to the EUT-POWER output, between the selected outputs, i.e. "L1 to N", "L1 to PE", or "N to PE".

10 Tests as per IEC 61000-4-12: Ring Wave

This chapter provides information on generator calibration and verification as well as on testing setups for immunity tests according to the latest edition of IEC 61000-4-4: "Testing and measurement techniques - Ring wave immunity test".



To perform this test your IMU-MGE generator must be equipped with one of the following modules:

- EXT-IMU3000 R6
- EXT-IMU3000 R8



This test is only available on the IMU-MGS generator. However in the following pictures, as in all other tests in this manual, an IMU-MGS generator is shown.

10.1 Immunity Tests



For coupling on external power lines, e.g. using an external three-phase CDN, or coupling on data lines via external data line CDNs, please refer to the chapters on power line and data line CDNs.

10.1.1 Power Line Coupling with Internal CDN

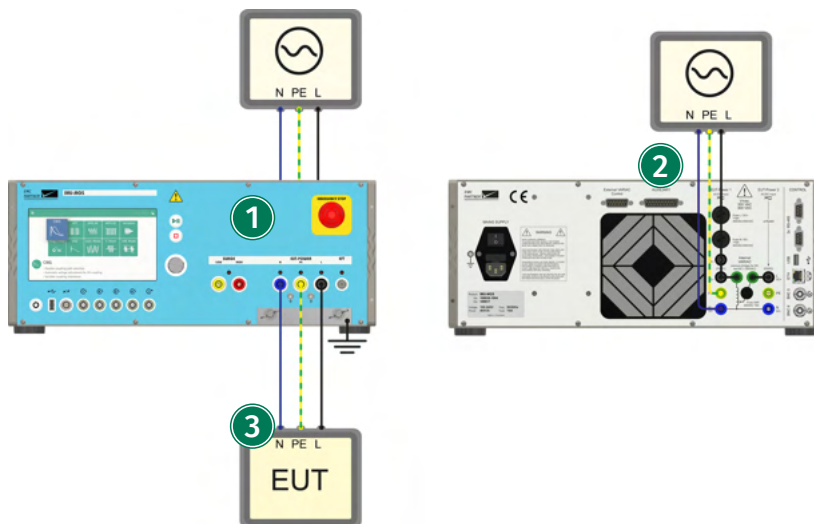

IMU-MGE

1 Generator

On your IMU-MGE generator select the "Ringwave" immunity test and set the test parameters according to your needs. Select the (Coupling) menu tab, and set "Device" to internal and "Coupling" to "L1 to N", "L1 to PE", or "N to PE" according to your needs. Set the Output Impedance, Test Levels, and Timing according to your needs.

2 CDN Power Input

Connect Line, Neutral and Earth on the rear panel of your generator to the public power mains

or your voltage source and switch on PWR1 or PWR2. For further information see the section "EUT Power".

3 Equipment Under Test (EUT)

Connect the EUT to the output of the internal CDN (EUT-POWER).

10.2 Calibration

10.2.1 Calibration of the Direct Output

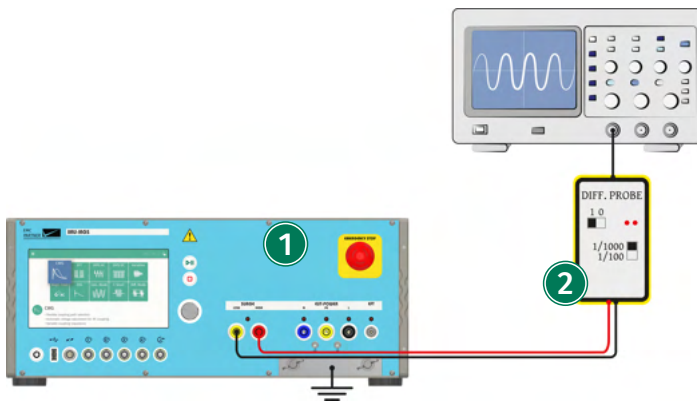

IMU-MGE - V-PROBE-SI

1 Generator

On your IMU-MGE generator select the "Ringwave" immunity test and set the test parameters according to your needs. Select the (Coupling) menu tab, and set "Device" to internal and "Coupling" to Impulse Out. Set the Output Impedance, Test Levels, and Timing according to your needs.

2 Differential Probe

Connect a differential probe with sufficient specifications, e.g. V-PROBE-SI, to the direct impulse output (Surge - Low and High) of your generator.

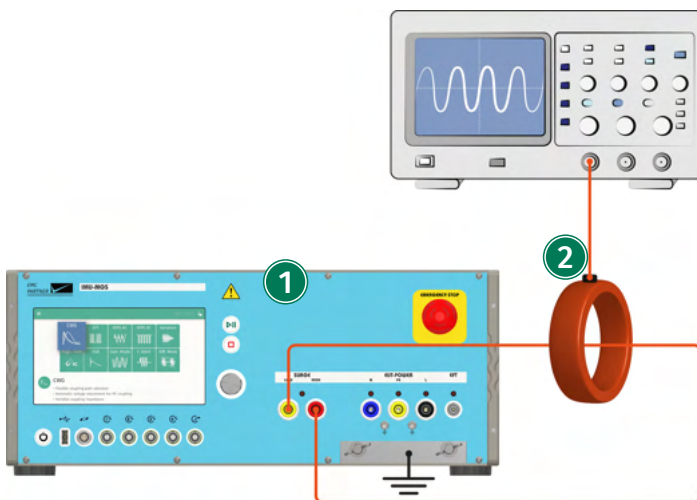

IMU-MGE - I-PROBE-P101

1 Generator

On your IMU-MGE generator select the "Ringwave" immunity test and set the test parameters according to your needs. Select the (Coupling) menu tab, and set "Device" to internal and "Coupling" to Impulse Out. Set the Output Impedance, Test Levels, and Timing according to your needs.

2 Current Probe

Connect a current probe with sufficient specifications, e.g. I-PROBE-P101, to the direct impulse output (Surge - between Low and High) of your generator.

10.2.2

Calibration of the CDN Output

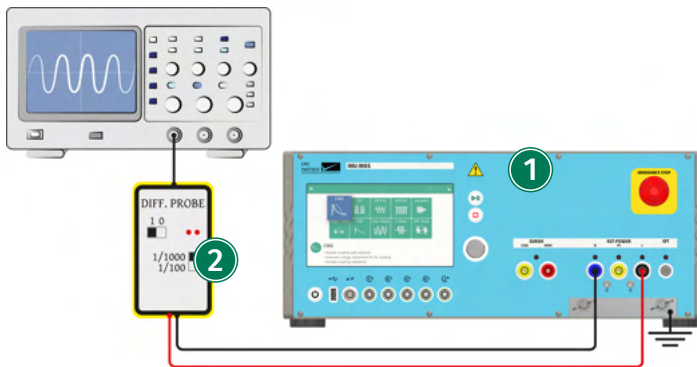

IMU-MGE - V-PROBE-SI

1 Generator

On your IMU-MGE generator select the "Ringwave" immunity test and set the test parameters according to your needs. Select the (Coupling) menu tab, and set "Device" to internal and "Coupling" to "L1 to N", "L1 to PE", or "N to PE" according to your needs. Set the Output Impedance, Test Levels, and Timing according to your needs.

2 Differential Probe

Connect a differential probe with sufficient specifications, e.g. V-PROBE-SI, to the EUT-POWER output, between the selected outputs, i.e. "L1 to N", "L1 to PE", or "N to PE".

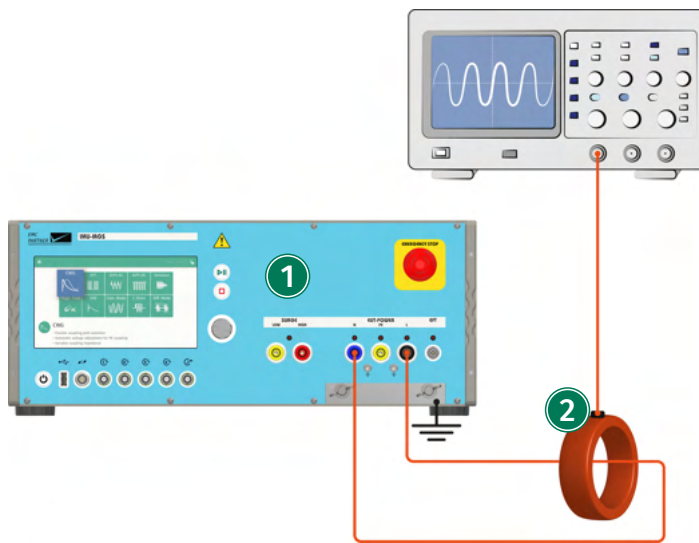

IMU-MGE - I-PROBE-P101

1 Generator

On your IMU-MGE generator select the "Ringwave" immunity test and set the test parameters according to your needs. Select the (Coupling) menu tab, and set "Device" to internal and "Coupling" to "L1 to N", "L1 to PE", or "N to PE" according to your needs. Set the Output Impedance, Test Levels, and Timing according to your needs.

2 Current Probe

Connect a current probe with sufficient specifications, e.g. I-PROBE-P101, to the EUT-POWER output, between the selected outputs, i.e. "L1 to N", "L1 to PE", or "N to PE".

11 Tests as per IEC 61000-4-8: AC Magnetic Fields

This chapter provides information on generator calibration and verification as well as on testing setups for immunity tests according to the latest edition of IEC 61000-4-8: "Testing and measurement techniques - Power frequency magnetic field immunity test".



To perform these tests with your your IMU-MGS or IMU-MGE generator must have one or more of the following modules/accessories

- EXT-IMU V (internal variac)
- VAR-EXT1000 (external variac)
- PS3 (programmable power supply)

as well as one of the following antennas:

- MF1000-1
- MF1000-2
- MF1000-3



Connect your IMU-MGS or IMU-MGE generator to the power source of your choice (mains, external variac, external power supply). Please refer to the chapter EUT Power for additional information.



Both antennas MF1000-1 and MF1000-2 only differ in their size, MF1000-3 is also very similar to the other two (with simpler connections). Therefore in the following pictures, only setups for the antenna MF1000-1 and MF1000-3 are shown.

11.1 Immunity Tests

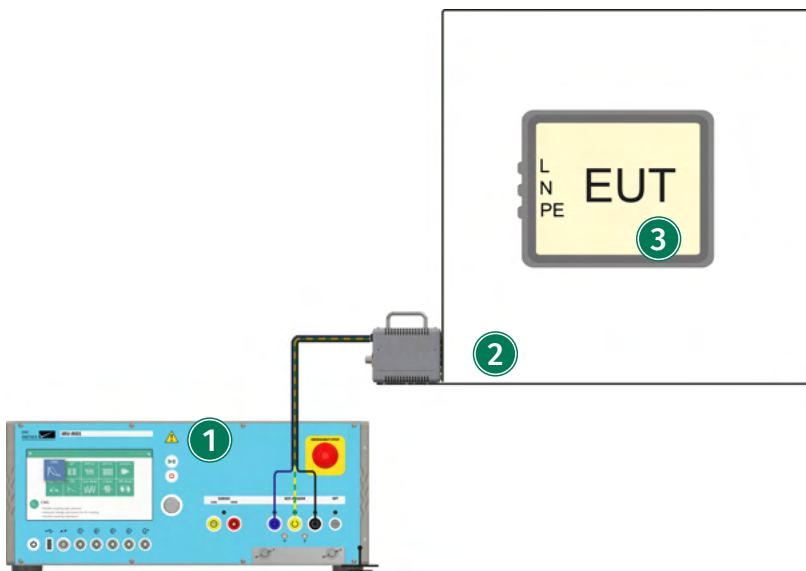

IMU-MGS or IMU-MGE - EXT-IMU V or VAR-EXT1000 or PS3 - MF1000-1 or MF1000-2

① Generator

On your IMU-MGS or IMU-MGE generator select the "Magnetic Field" immunity test and set the

test parameters according to your needs. In the (Level) menu tab select the power source you are using (internal variac, external variac or PS3 power supply). Select the (Coupling) menu tab, and set "Coil" to MF1000-1 or MF1000-2. Set the correct Range on the generator as well as on your antenna.

- ② **Antenna**
Connect the antenna to Line, Neutral and PE at the CDN output (EUT POWER) of your generator.
- ③ **Equipment Under Test (EUT)**
Place the EUT in the middle of the antenna.

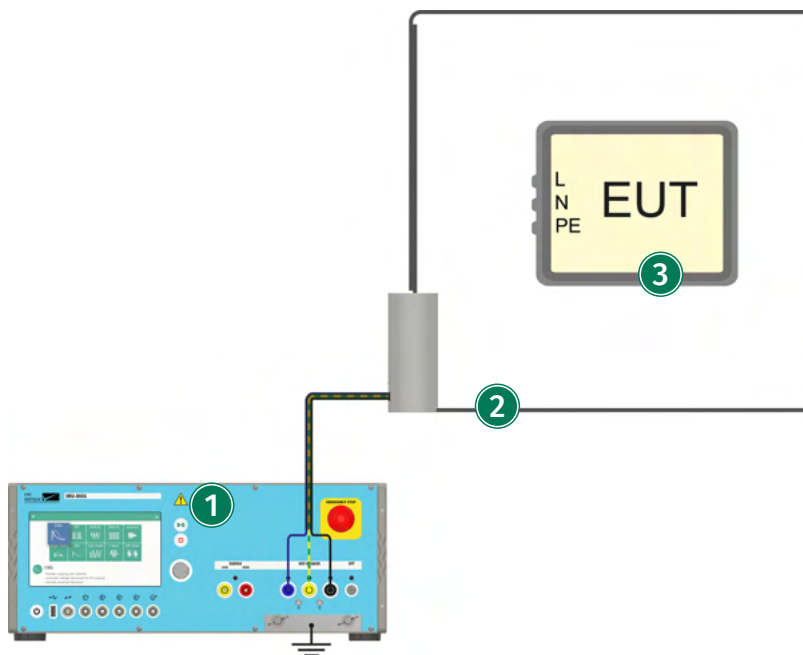

IMU-MGS or IMU-MGE - EXT-IMU V or VAR-EXT1000 or PS3 - MF1000-3

- ① **Generator**
On your IMU-MGS or IMU-MGE generator select the "Magnetic Field" immunity test and set the test parameters according to your needs. In the (Level) menu tab select the power source you are using (internal variac, external variac or PS3 power supply). Select the (Coupling) menu tab, and set "Coil" to MF1000-3. Set the correct Range on the generator as well as on your antenna.

- ② **Antenna**
Connect the antenna to Line, Neutral and PE at the CDN output (EUT POWER) of your generator.



When using MF1000-1 or MF1000-2, all bridges must be in the upper position.



When using the MF1000-3, simply connect the power plug to the base of the antenna.

- ③ **Equipment Under Test (EUT)**
Place the EUT in the middle of the antenna.

11.2 Calibration

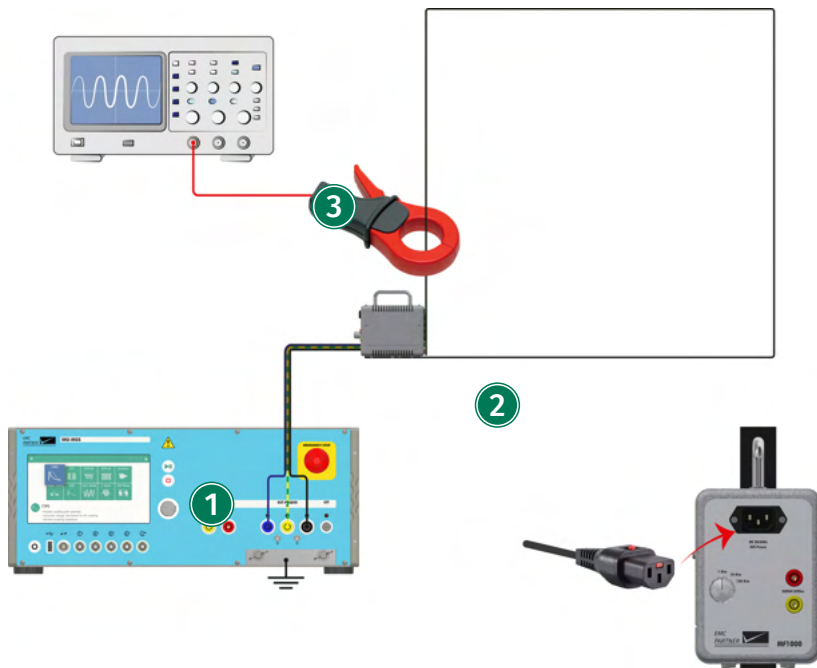

IMU-MGS or IMU-MGE - EXT-IMU V or VAR-EXT1000 or PS3 - MF1000-1 or MF1000-2

1 Generator

On your IMU-MGS or IMU-MGE generator select the "Magnetic Field" immunity test and set the test parameters according to your needs. In the (Level) menu tab select the power source you are using (internal variac, external variac or PS3 power supply). Select the (Coupling) menu tab, and set "Coil" to MF1000-1 or MF1000-2. Set the correct Range on the generator as well as on your antenna.

2 Antenna

Connect the antenna to Line, Neutral and PE at the CDN output (EUT POWER) of your generator.



When using MF1000-1 or MF1000-2, all bridges must be in the upper position.

3 Measurement

Place a current probe with sufficient specifications around the antenna frame to measure the current and infer the magnetic field strength inside the coil.

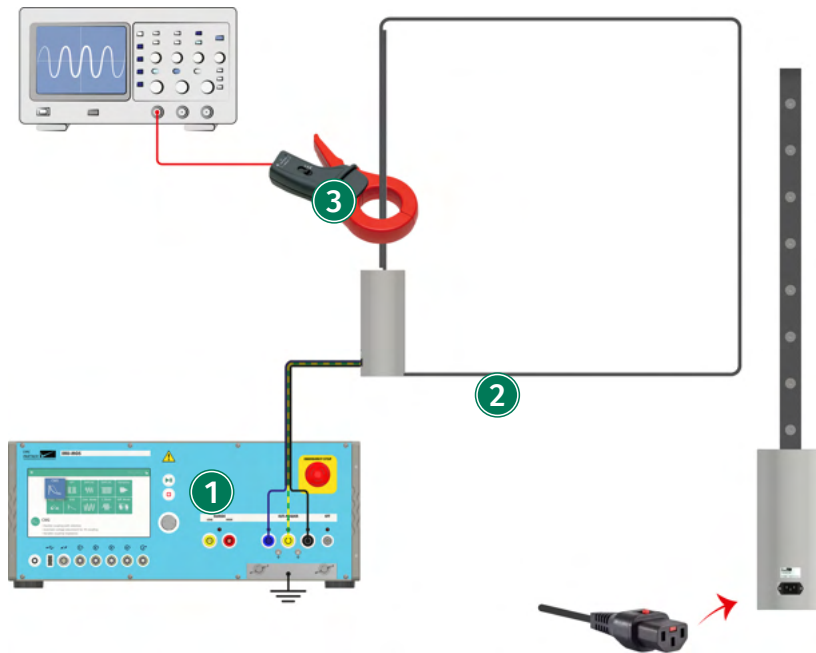

IMU-MGS or IMU-MGE - EXT-IMU V or VAR-EXT1000 or PS3 - MF1000-3

1 Generator

On your IMU-MGS or IMU-MGE generator select the "Magnetic Field" immunity test and set the test parameters according to your needs. In the (Level) menu tab select the power source you are using (internal variac, external variac or PS3 power supply). Select the (Coupling) menu tab, and set "Coil" to MF1000-3. Set the correct Range on the generator as well as on your antenna.

2 Antenna

Connect the antenna to Line, Neutral and PE at the CDN output (EUT POWER) of your generator.



When using the MF1000-3, simply connect the power plug to the base of the antenna.

3 Measurement

Place a current probe with sufficient specifications around the antenna frame to measure the current and infer the magnetic field strength inside the coil.

12 Tests as per IEC 61000-4-9: Impulse Magnetic Fields

This chapter provides information on generator calibration and verification as well as on testing setups for immunity tests according to the latest edition of IEC 61000-4-8: "Testing and measurement techniques - Impulse magnetic field immunity test".



To perform this test your IMU-MGS or IMU-MGE generator must be equipped with one of the following modules:

- EXT-IMU4000 S4 or S5 (IMU-MGS generator)
- EXT-IMU3000 S6 or S8 (IMU-MGE generator)

as well as one of the following antennas:

- MF1000-1
- MF1000-2



Both antennas MF1000-1 and MF1000-2 only differ in their size. Therefore in the following pictures, only the MF1000-1 antenna is shown. The setup for the MF1000-2 antenna is identical.

12.1 Immunity Tests

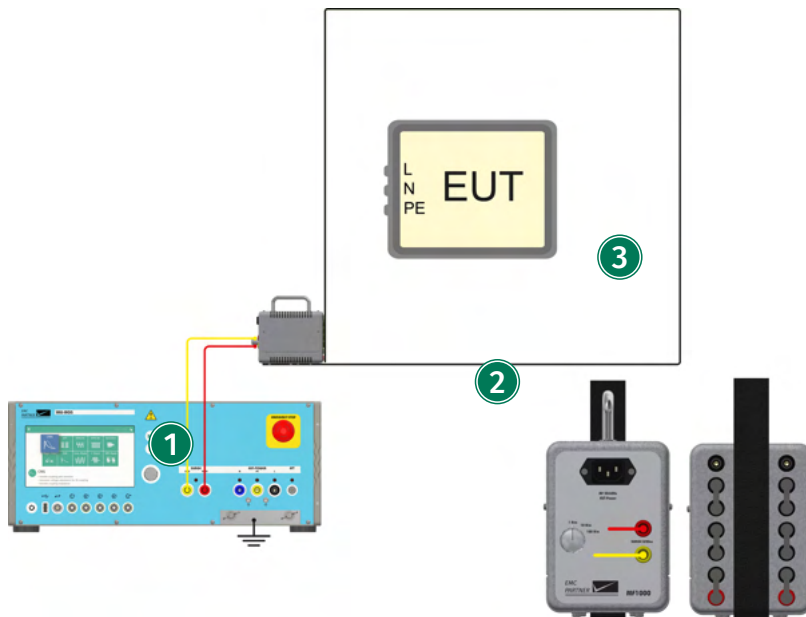

IMU-MGS or IMU-MGE - MF1000-1 or MF1000-2

1 Generator

On your IMU-MGS or IMU-MGE generator select the "CWG" immunity test and set the test parameters according to your needs. Select the (Coupling) menu tab, and set "Device" to MF1000-1 or MF1000-2 and "Coupling" to Impulse Out.

2 Antenna

The type of the antenna depends on the desired level and the size of the EUT. Connect either

MF1000-1 or MF1000-2 to the Surge impulse output of the generator. All bridges must be in the lower position.

3 Equipment Under Test (EUT)

Place the EUT in the middle of the antenna.

12.2 Calibration

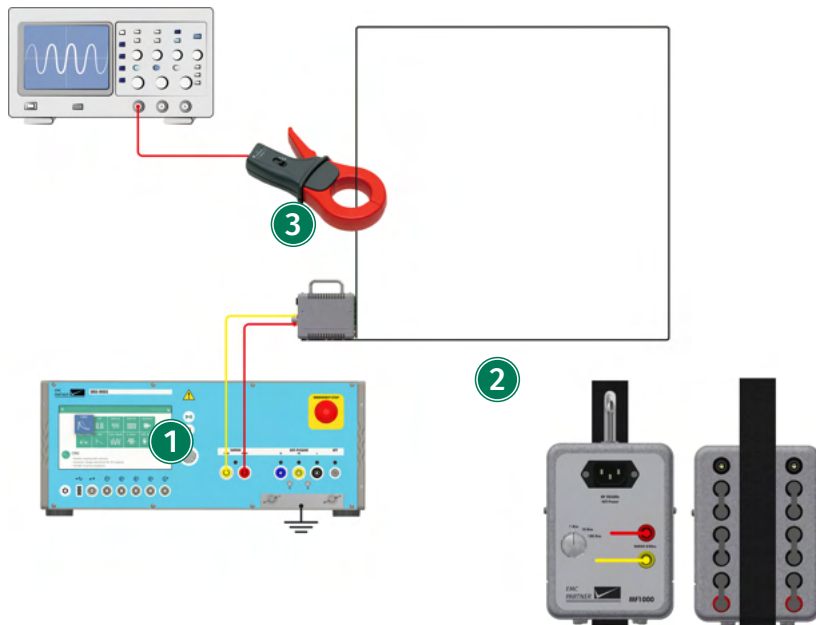

IMU-MGS or IMU-MGE - MF1000-1 or MF1000-2

1 Generator

On your IMU-MGS or IMU-MGE generator select the "CWG" immunity test and set the test parameters according to your needs. Select the (Coupling) menu tab, and set "Device" to MF1000-1 or MF1000-2 and "Coupling" to Impulse Out.

2 Antenna

The type of the antenna depends on the desired level and the size of the EUT. Connect either MF1000-1 or MF1000-2 to the Surge impulse output of the generator.



When using MF1000-1 or MF1000-2, all bridges must be in the lower position.

3 Measurement

Place a current probe with sufficient specifications around the antenna frame to measure the current and infer the magnetic field strength inside the coil.

13 Tests as per IEC 61000-4-11: AC Dips, Interrupts and Variations <16 A

This chapter provides information on generator calibration and verification as well as on testing setups for immunity tests according to the latest edition of IEC 61000-4-11: "Voltage dips, short interruptions and voltage variations immunity tests".



To perform these tests your IMU-MGS or IMU-MGE generator must be equipped with the following modules:

- EXT-IMU D
- EXT-IMU V or VAR-EXT1000

13.1 Immunity Tests

13.1.1 Tests using the Internal Variac

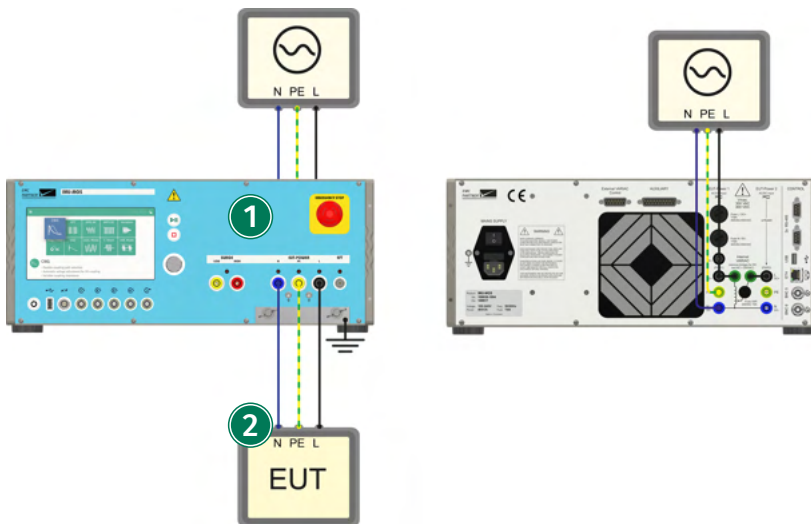

IMU-MGS or IMU-MGE

1 Generator

On your IMU-MGS or IMU-MGE generator select the "DIPS AC" immunity test and set the test parameters, e.g. level and PWR2 Mode, according to your needs, in the (Coupling) menu tab set the "Device" to internal and "Source" to the employed internal variac. Your generator should be grounded.

2 Equipment Under Test (EUT)

Connect the EUT to the EUT power outputs on the generator front panel.

13.1.2 Tests using the External Variac

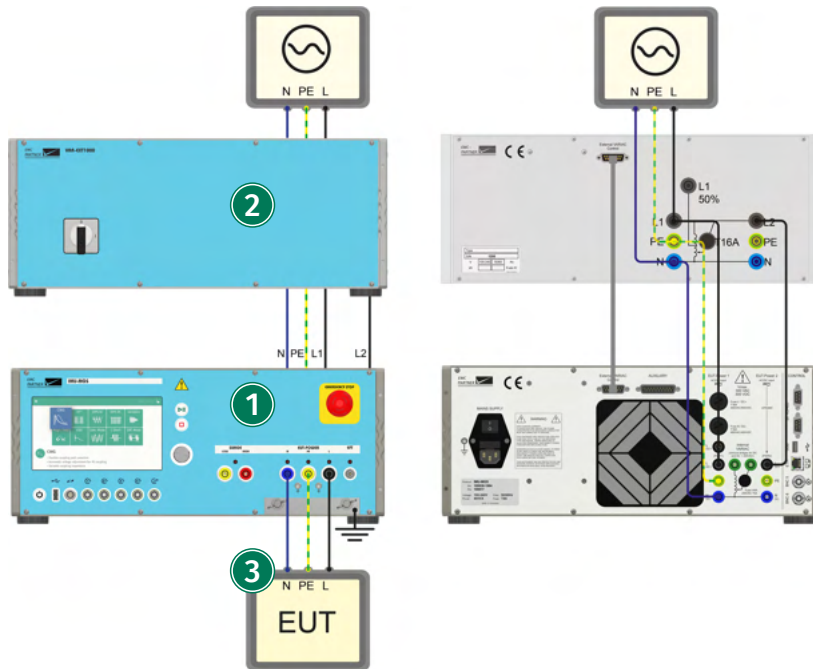

IMU-MGS or IMU-MGE - VAR-EXT1000

1 Generator

On your IMU-MGS or IMU-MGE generator select the "DIPS AC" immunity test and set the test parameters, e.g. level and PWR2 Mode, according to your needs, in the (Coupling) menu tab set the "Device" to internal and "Source" to the employed external variac. Your generator should be grounded.

2 External Variac VAR-EXT1000

Connect the power inputs of the external variac (L1, PE, N) to the same power supply (mains) as your generator and the output of the external variac (L2) to the PWR2 input of your generator. All connections are made on the rear panels of the VAR-EXT1000 and the generator. Also connect both the external variac and the generator via the "External Variac Control" connections on the rear panel.

3 Equipment Under Test (EUT)

Connect the EUT to the EUT power outputs on the generator front panel.

13.1.3 Tests using the External Tapped Transformer

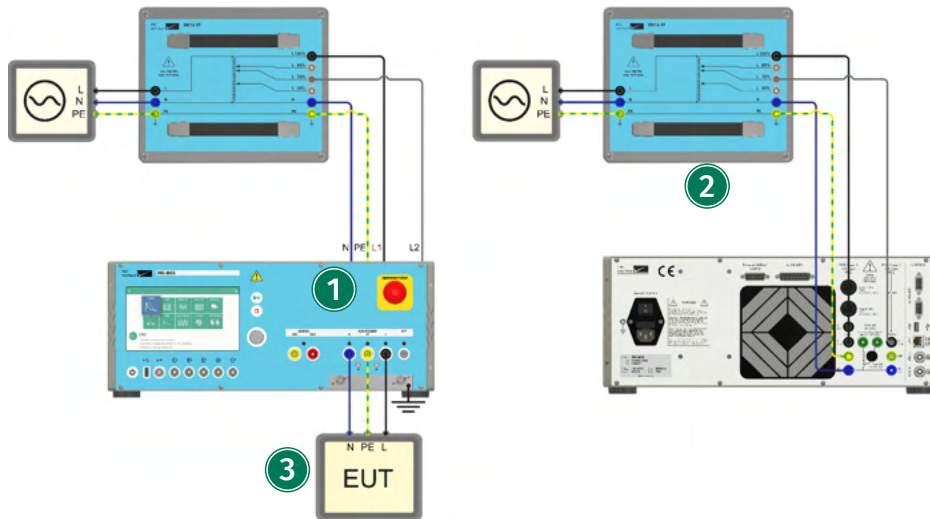

IMU-MGS or IMU-MGE - SRC16-1P

① Generator

On your IMU-MGS or IMU-MGE generator select the "DIPS AC" immunity test and set the test parameters, e.g. level and PWR2 Mode, according to your needs, in the (Coupling) menu tab set the "Device" to internal and "Source" to the employed SRC16-1P. Your generator should be grounded.

② Fixed Tapped Transformer SRC16-1P

SRC16-1P Output Line (100%), Neutral (N) and Earth (PE) from the output of the SRC16-1P are connected to the PWR1 inputs on the generator rear panel. The tapped output (80%, 70%, or 40%) of the SRC16-1P is connected to the PWR2 input (L2) on the generator rear panel.

③ Equipment Under Test (EUT)

Connect the EUT to the EUT power outputs on the generator front panel.

13.2 Calibration



In this section only the calibration setups for use with the internal variac are shown, calibration setups for use with an external variac or a fixed tapped transformer are identical. Connection setups for the external variac or the fixed tapped transformer are given in the chapter "EUT Power".

13.2.1 Verification of the Voltage Variation

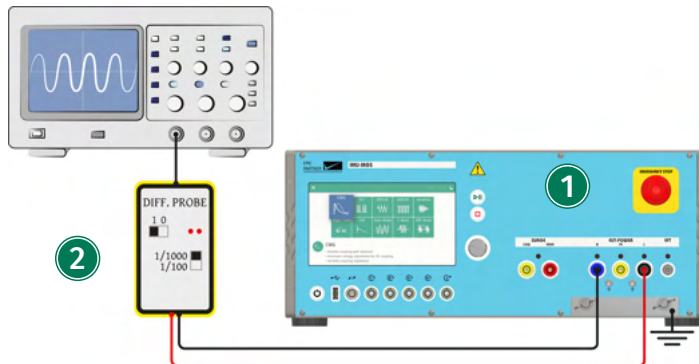

IMU-MGS or IMU-MGE - V-PROBE-SI

1 Generator

On your IMU-MGS or IMU-MGE generator select the "Variation" immunity test and set the test parameters, e.g. Vnom, level, and time, according to your needs, in the (Options) menu tab set the "Variac" to internal.

2 Measurement

Connect a voltage probe with sufficient specifications, e.g. V-PROBE-SI, or an appropriate voltage meter to the CDN output of your generator.

13.2.2 Verification of the Inrush Current and Switching Time

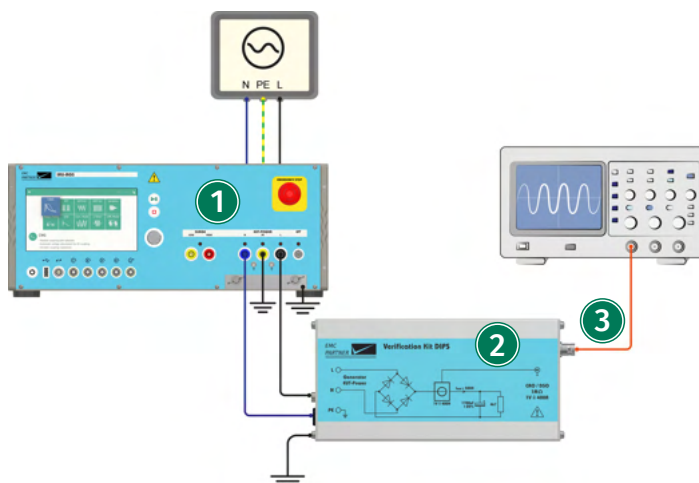

IMU-MGS or IMU-MGE - VERI-DIPS

1 Generator

On your IMU-MGS or IMU-MGE generator select the "DIPS AC" immunity test and set the test parameters, e.g. level and PWR2 Mode, according to your needs, in the (Coupling) menu tab set the "Device" to internal and "Source" to the employed source (internal variac, external variac, SRC16-1P). Your generator should be grounded.

2 Verification Device VERI-DIPS

Connect the VERI-DIPS verification device to the CDN power output (Line and Neutral) of your generator. The VERI-DIPS should be grounded as well.

3 CRO Output

Connect the BNC output on the VERI-DIPS to an oscilloscope with a 1 MOhm input impedance.

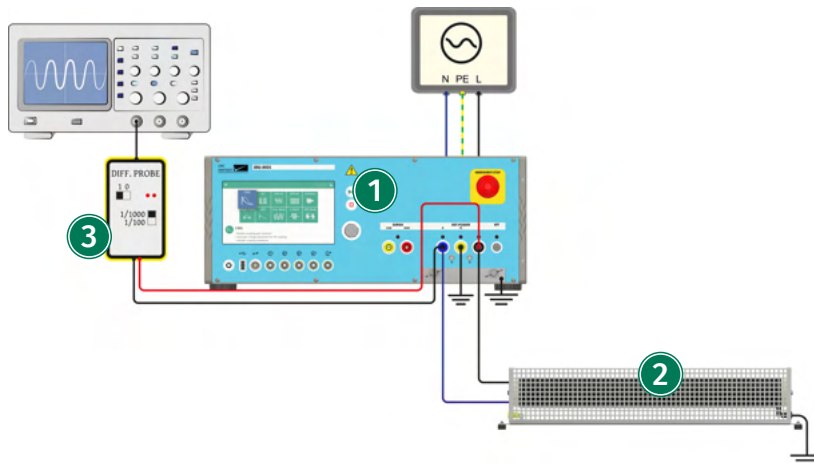

IMU-MGS or IMU-MGE - DIPS100E

1 Generator

On your IMU-MGS or IMU-MGE generator select the "DIPS AC" immunity test and set the test parameters, e.g. level and PWR2 Mode, according to your needs, in the (Coupling) menu tab set the "Device" to internal and "Source" to the employed source (internal variac, external variac, SRC16-1P). Your generator should be grounded.

2 DIPS100E

Connect the 100 Ohm verification resistor DIPS100E to the EUT-POWER output, i.e. between Line and Neutral.

3 Measurement

Connect a differential probe with sufficient specifications, e.g. V-PROBE-SI, to the EUT-POWER output, i.e. between Line and Neutral.

14 Tests as per IEC 61000-4-34: AC Dips, Interrupts and Variations >16 A

This chapter provides information on generator calibration and verification as well as on testing setups for immunity tests according to the latest edition of IEC 61000-4-34: "Voltage dips, short interruptions and voltage variations immunity tests for equipment with mains current more than 16 A per phase."

14.1 Hardware Description

14.1.1 PFS32

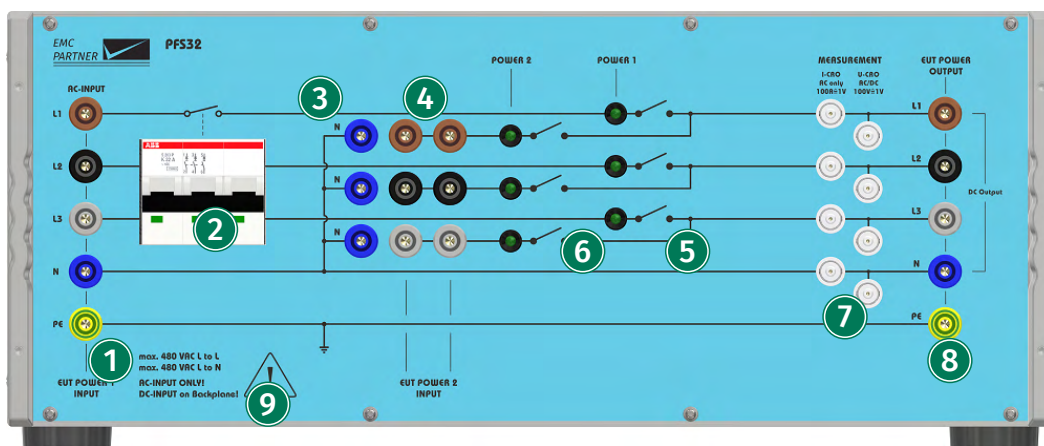

① AC-Input

Three-phase AC power input (L1, L2, L3, N, PE)



Do not connect DC power on the front panel AC inputs. For DC interruptions a dedicated DC inputs on the rear of the device must be used. The DC can then be connected to the EUT from L1 and N on the front panel.



Before connecting a DC source to the device, remove all synchronization cables to the IMU-MGS or IMU-MGE generator, (L1,N,PE inputs on the generator rear panel).

② Circuit Breaker

Three-phase circuit breaker for device protection.

③ Neutral Connections

Additional Neutral connections.

④ EUT Power 2 Input

Input connectors for Power 2, e.g. from SRC32 or other additional power source.

⑤ Power 1 Switch

Three-phase switches for Power 1 with LED indicators.

⑥ Power 2 Switch

Three-phase switches for Power 2 with LED indicators.

- ⑦ **DC Input**
DC+ and DC- input connectors for DC power.

14.1.2

PFS75

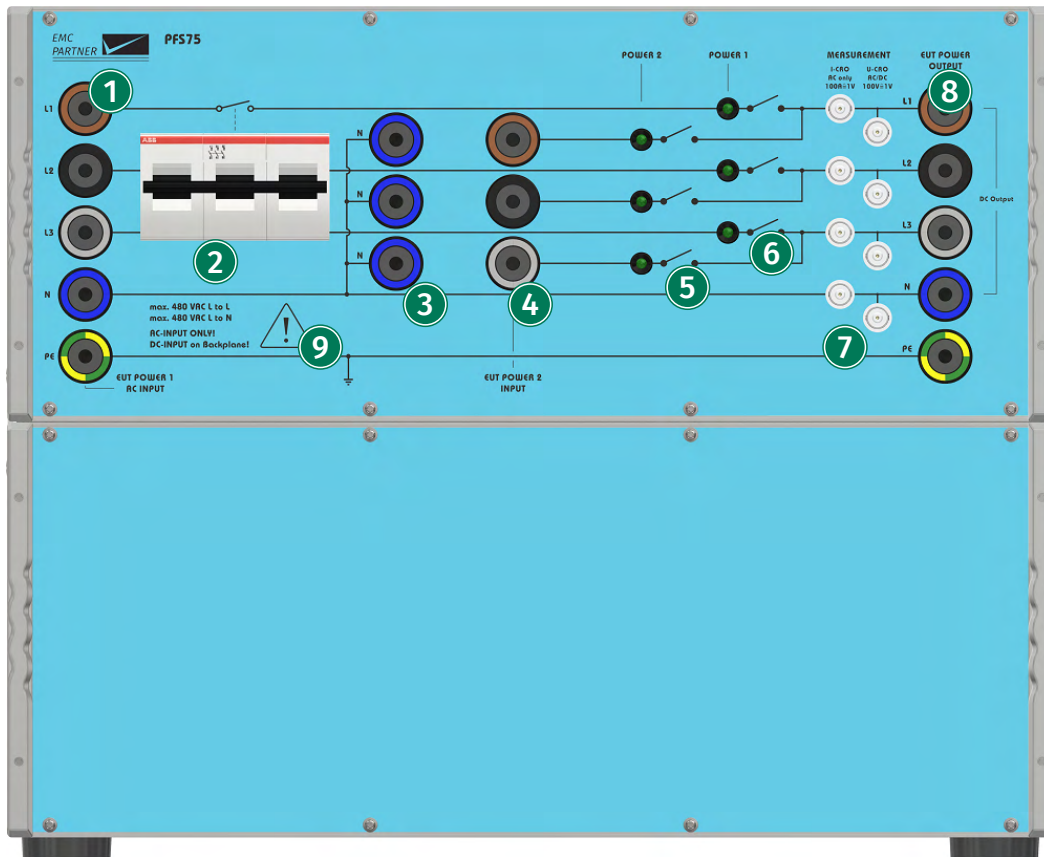

- ① **AC-Input**
Three-phase AC power input (L1, L2, L3, N, PE)



Do not connect DC power on the front panel AC inputs. For DC interruptions a dedicated DC inputs on the rear of the device must be used. The DC can then be connected to the EUT from L1 and N on the front panel.



Before connecting a DC source to the device, remove all synchronization cables to the IMU-MGS or IMU-MGE generator, (L1,N,PE inputs on the generator rear panel).

- ② **Circuit Breaker**
Three-phase circuit breaker for device protection.
- ③ **Neutral Connections**
Additional Neutral connections.
- ④ **EUT Power 2 Input**
Input connectors for Power 2, e.g. from SRC32 or other additional power source.

- ⑤ **Power 1 Switch**
Three-phase switches for Power 1 with LED indicators.
- ⑥ **Power 2 Switch**
Three-phase switches for Power 2 with LED indicators.
- ⑦ **Measurement**
BNC measurement outputs for your oscilloscope. Allows direct measurement of all four currents (L1, L2, L3, N) and voltages (L1, L2, L3, N) at the EUT power port.
- ⑧ **EUT Power Output**
Three-phase AC power output (L1, L2, L3, N, PE) for the EUT. L1 and N can be used as outputs for DC equipment (Dc power input on the rear on the device).
- ⑨ **Input Specifications Panel**
Maximum input voltage and current specifications.



Take care not to exceed these values for the maximum input voltages and currents.

14.1.3

SRC32

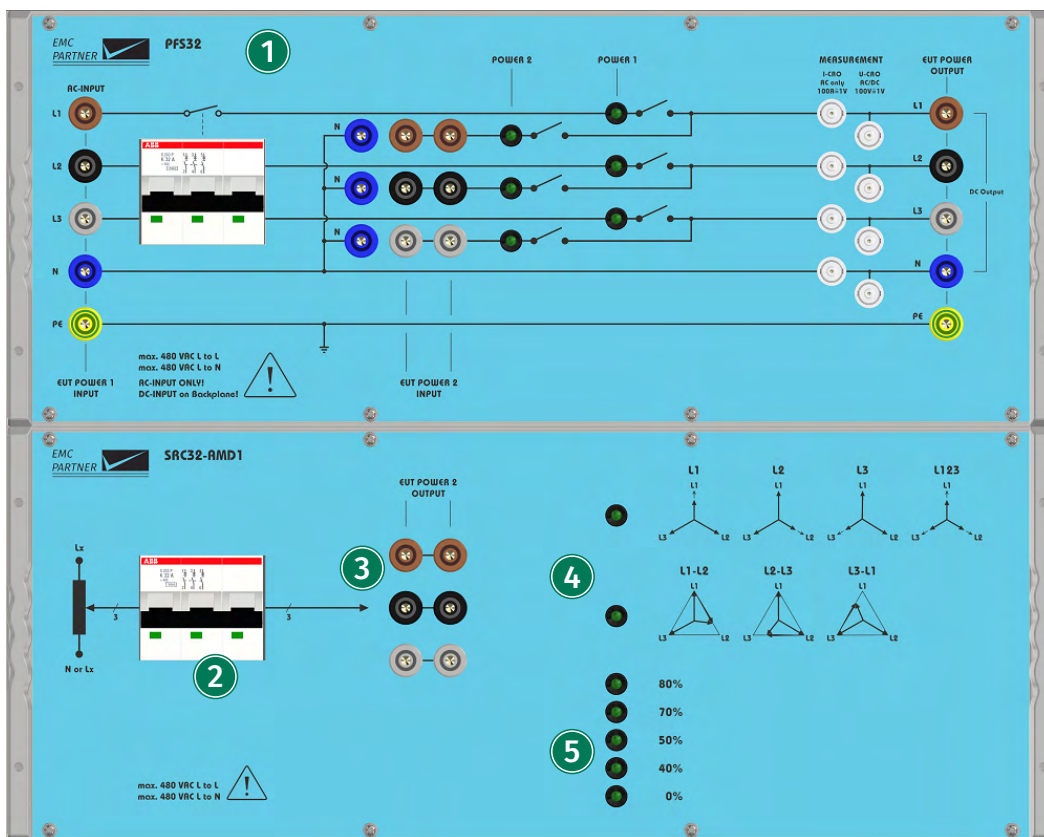

The SRC32 and SRC75 are mounted in a 36 UH rack, with the mains socket located on lower part of the front panel. A country specific mains cable is delivered with the equipment, this should be used to connect to the mains power supply. A mains fuse is located in the socket housing. The value is indicated on the equipment type plate.



Take care to ensure the power main matches the power ratings on the equipment type plate.

The generator must always be connected to protective earth.

① PFS32

The PFS32 is shown in this figure in combination with the SRC32.



Do not connect DC power on the front panel AC inputs. For DC interruptions a dedicated DC inputs on the rear of the device must be used. The DC can then be connected to the EUT from L1 and N on the front panel.



Before connecting a DC source to the device, remove all synchronization cables to the IMU-MGS or IMU-MGE generator, (L1,N,PE inputs on the generator rear panel).

② Circuit Breaker

Three-phase circuit breaker for device protection.

③ EUT Power 2 Output

Three-phase EUT power 2 output connectors, to connect to the PFS32.

④ Phase Configuration Indicators

LED indicators to show if Line-to-Line (Delta configuration) or Line-to-Neutral (Star configuration) is selected.

⑤ Voltage Level Indicators

LED indicators to show the level of Power 2 (80%, 70%, 50%, 40% or 0%) is selected.

14.1.4

SRC75

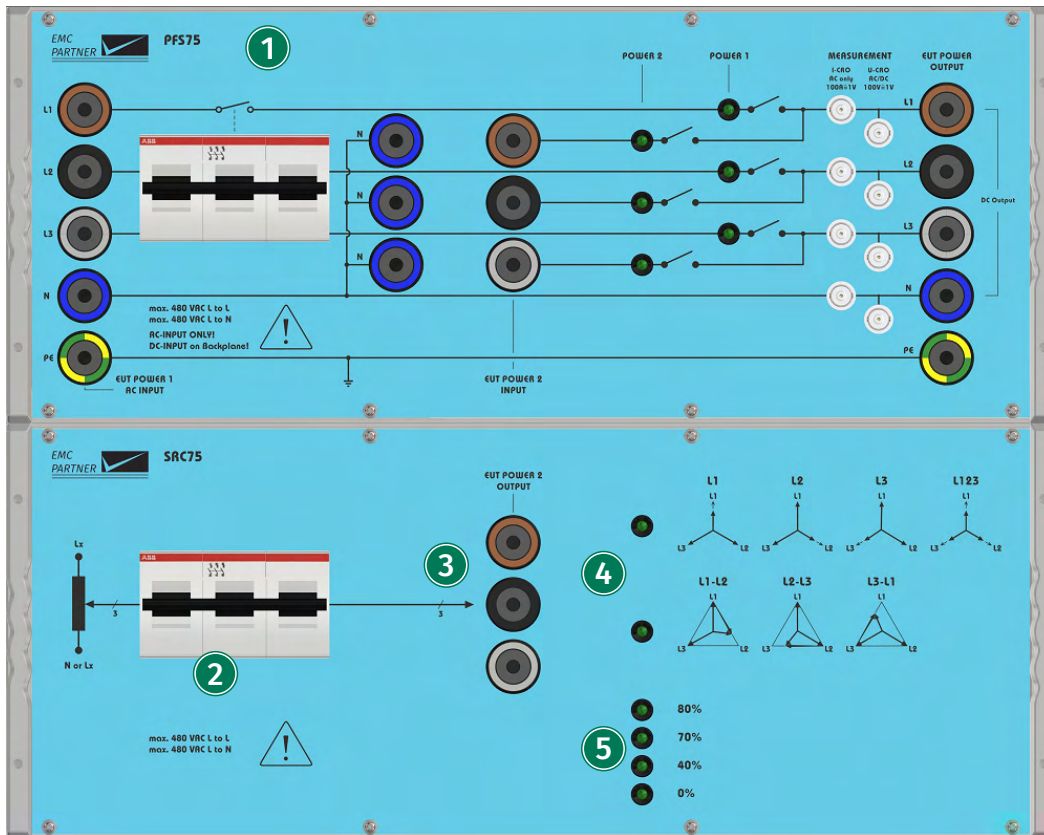

The SRC32 and SRC75 are mounted in a 36 UH rack, with the mains socket located on lower part of the front panel. A country specific mains cable is delivered with the equipment, this should be used to connect to the mains power supply. A mains fuse is located in the socket housing. The value is indicated on the equipment type plate.



Take care to ensure the power main matches the power ratings on the equipment type plate. The generator must always be connected to protective earth.

1 PFS75

The PFS75 is shown in this figure in combination with the SRC75.



Do not connect DC power on the front panel AC inputs. For DC interruptions a dedicated DC inputs on the rear of the device must be used. The DC can then be connected to the EUT from L1 and N on the front panel.



Before connecting a DC source to the device, remove all synchronization cables to the IMU-MGS or IMU-MGE generator, (L1,N,PE inputs on the generator rear panel).

2 Circuit Breaker

Three-phase circuit breaker for device protection.

- ③ **EUT Power 2 Output**
Three-phase EUT power 2 output connectors, to connect to the PFS75.
- ④ **Phase Configuration Indicators**
LED indicators to show if Line-to-Line (Delta configuration) or Line-to-Neutral (Star configuration) is selected.
- ⑤ **Voltage Level Indicators**
LED indicators to show the level of Power 2 (80%, 70%, 50%, 40% or 0%) is selected.

14.2 Immunity Tests

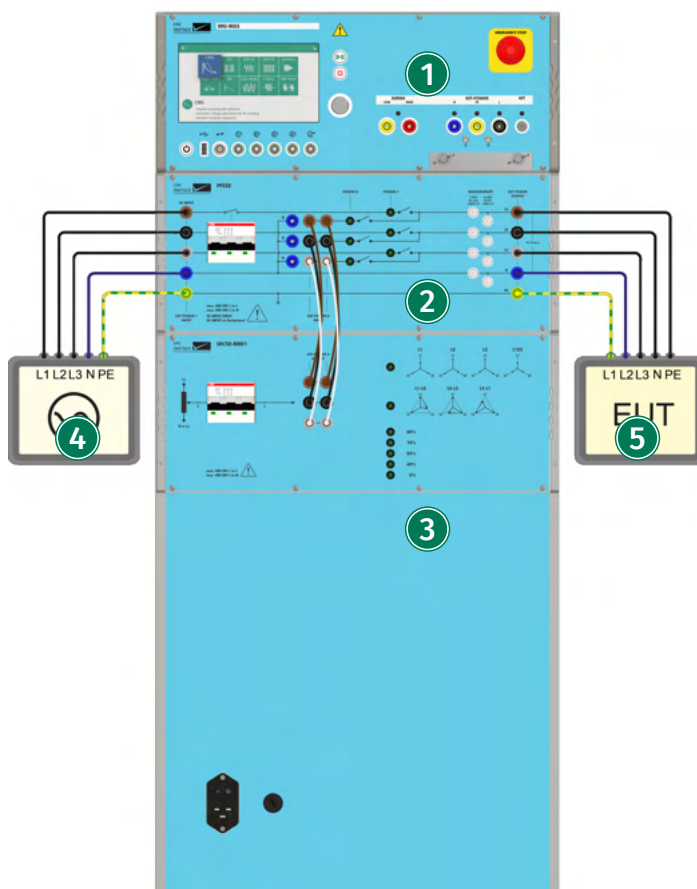

IMU-MGS or IMU-MGE - PFS32 - SRC32

- ① **Generator**
On your IMU-MGS or IMU-MGE generator select the "DIPS AC" immunity test and set the test parameters, e.g. level and PWR2 Mode, according to your needs, in the (Coupling) menu tab set the "Device" to external and "Source" to the employed source. Your generator should be grounded.
On the back of the generator make the control connection between the generator and the PFS using the provided RS485 cable. Also connect the PFS power outputs (L, N, PE) on the back of the

device to the EUT Power 1 input on the back of the IMU generator. This connection is necessary for synchronization.

2 PFS

Power Failure Switch for Three-Phase DIPS and Interrupts Testing.

3 SRC

Power Source for Three-Phase DIPS and Interrupts Testing. Connect the EUT Power 2 Output of the SRC with the EUT Power 2 Input of the PFS using the set of low impedance twisted cables, delivered with the device.

4 Three-Phase AC Source

Connect your three-phase AC source, or three-phase mains to the PFS.

5 Equipment Under Test (EUT)

Connect the EUT to the EUT power outputs on the PFS front panel.



Do not connect DC power on the front panel AC inputs. For DC interruptions a dedicated DC inputs on the rear of the device must be used. The DC can then be connected to the EUT from L1 and N on the front panel.

Before connecting a DC source to the device, remove all synchronization cables to the IMU-MGS or IMU-MGE generator, (L1, N, PE inputs on the generator rear panel).



The sequence of the connected phases L1, L2, L3 must be correct. When the sequence is not correct the synchronization of the interruptions / dips will not be correct. The sequence must be either measured with a three channel oscilloscope or with a phase sequence indicator.

14.3

Calibration



The sequence of the connected phases L1, L2, L3 must be correct. When the sequence is not correct the synchronization of the interruptions / dips will not be correct. The sequence must be either measured with a three channel oscilloscope or with a phase sequence indicator.

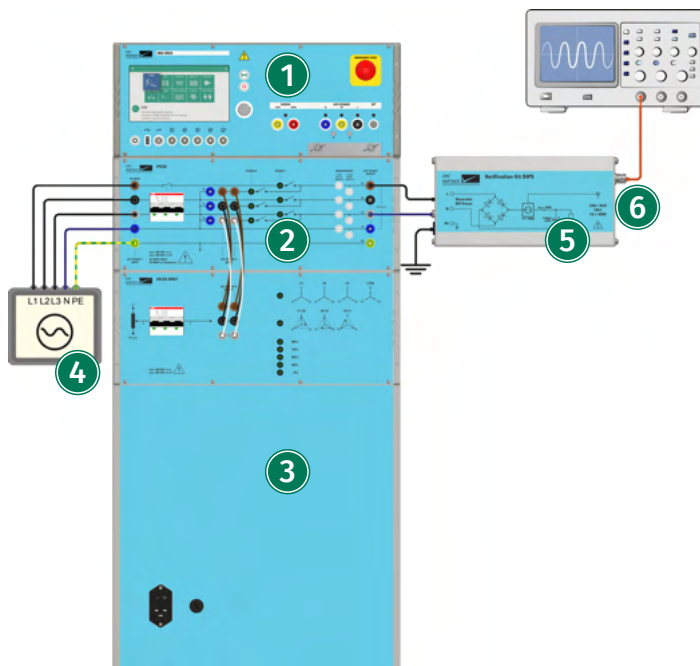

IMU-MGS or IMU-MGE - PFS32 - SRC32 - VERI-DIPS

1 Generator

On your IMU-MGS or IMU-MGE generator select the "DIPS AC" immunity test and set the test parameters, e.g. level and PWR2 Mode, according to your needs, in the (Coupling) menu tab set the "Device" to external and "Source" to the employed source. Your generator should be grounded.

On the back of the generator make the control connection between the generator and the PFS using the provided RS485 cable. Also connect the PFS power outputs (L, N, PE) on the back of the device to the EUT Power 1 input on the back of the IMU generator. This connection is necessary for synchronization.

2 PFS

Power Failure Switch for Three-Phase DIPS and Interrupts Testing.

3 SRC

Power Source for Three-Phase DIPS and Interrupts Testing.

Connect the EUT Power 2 Output of the SRC with the EUT Power 2 Input of the PFS using the set of low impedance twisted cables, delivered with the device.

4 Three-Phase AC Source

Connect your three-phase AC source, or three-phase mains to the PFS.

5 Verification Device VERI-DIPS

Connect the VERI-DIPS verification device to the CDN power output (Line and Neutral) of your generator. The VERI-DIPS should be grounded as well.

6 CRO-Output

Connect the BNC output on the VERI-DIPS to an oscilloscope with a 1M Ω input impedance.

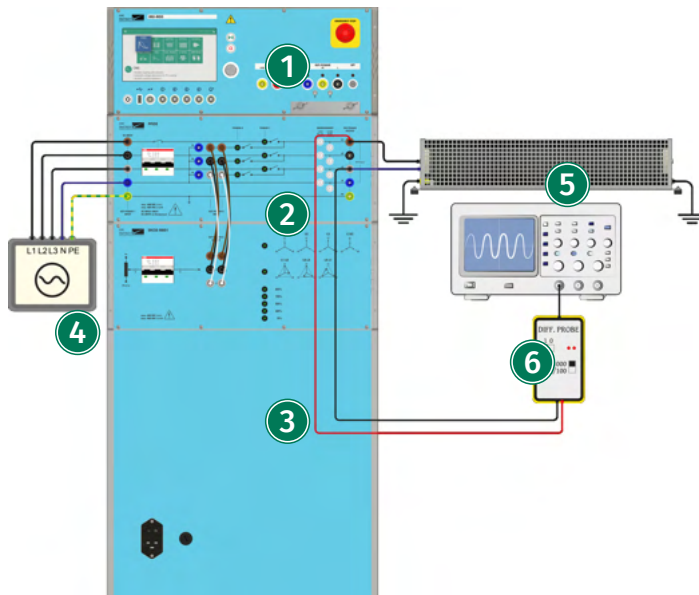

IMU-MGS or IMU-MGE - PFS32 - SRC32 - DIPS100E

1 Generator

On your IMU-MGS or IMU-MGE generator select the "DIPS AC" immunity test and set the test parameters, e.g. level and PWR2 Mode, according to your needs, in the (Coupling) menu tab set the "Device" to external and "Source" to the employed source. Your generator should be grounded.

On the back of the generator make the control connection between the generator and the PFS using the provided RS485 cable. Also connect the PFS power outputs (L, N, PE) on the back of the device to the EUT Power 1 input on the back of the IMU generator. This connection is necessary for synchronization.

2 PFS

Power Failure Switch for Three-Phase DIPS and Interrupts Testing.

3 SRC

Power Source for Three-Phase DIPS and Interrupts Testing. Connect the EUT Power 2 Output of the SRC with the EUT Power 2 Input of the PFS using the set of low impedance twisted cables, delivered with the device.

4 Three-Phase AC Source

Connect your three-phase AC source, or three-phase mains to the PFS.

5 DIPS100E

Connect the 100Ohm verification resistor DIPS100E to the EUT-POWER output, i.e. between Line and Neutral.

6 Measurement

Connect a differential probe with sufficient specifications, e.g. V-PROBE-SI, to the EUT-POWER output, i.e. between Line and Neutral.

15 Tests as per IEC 61000-4-29: DC Dips, Interrupts and Variations

This chapter provides information on generator calibration and verification as well as on testing setups for immunity tests according to the latest edition of IEC 61000-4-11: "Testing and measurement techniques - Voltage dips, short interruptions and voltage variations on DC input power port immunity tests".



To perform these tests your IMU-MGS or IMU-MGE generator must be equipped with the following module:

- EXT-IMU D

as well as be connected to at least one external power supply, e.g. a PS3 power supply: DC interruptions and variations require one PS3 and DC dips require two PS3.

15.1 Immunity Tests

15.1.1 DC Variations and Interrupts Testing

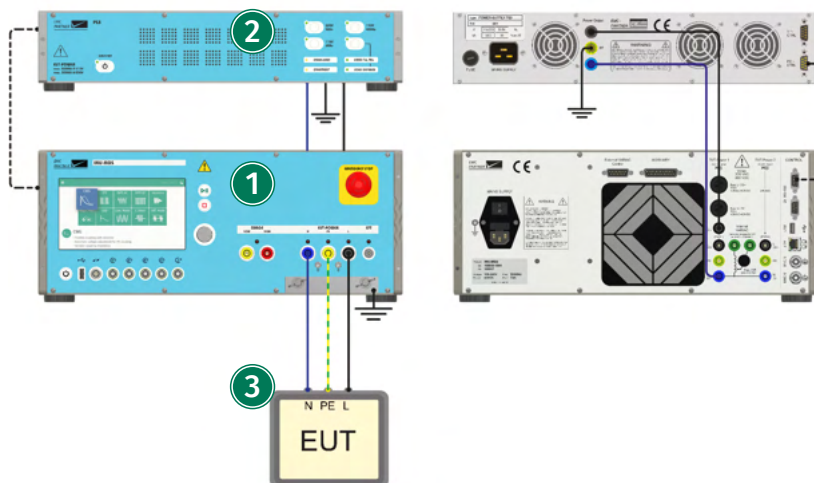

IMU-MGS or IMU-MGE - PS3 - RS485-RS232 ADAPTER

1 Generator

On your IMU-MGS or IMU-MGE generator select the "DIPS DC" immunity test and set the test parameters according to your needs, in the (Coupling) menu tab set the "Device" to internal and "Source" to the employed source (Your own power supply or the PS3). Your generator should be grounded.

2 PS3

A PS3 power supply is required to generate a DC voltage for DC Interrupts tests. Connect it to the mains, to the PWR1 inputs on the rear panel of your generator and to your generator via an RS485-RS232 ADAPTER.

3 Equipment Under Test (EUT)

Connect the EUT to the CDN output (EUT POWER) of your generator.

15.1.2 DC Dips Testing

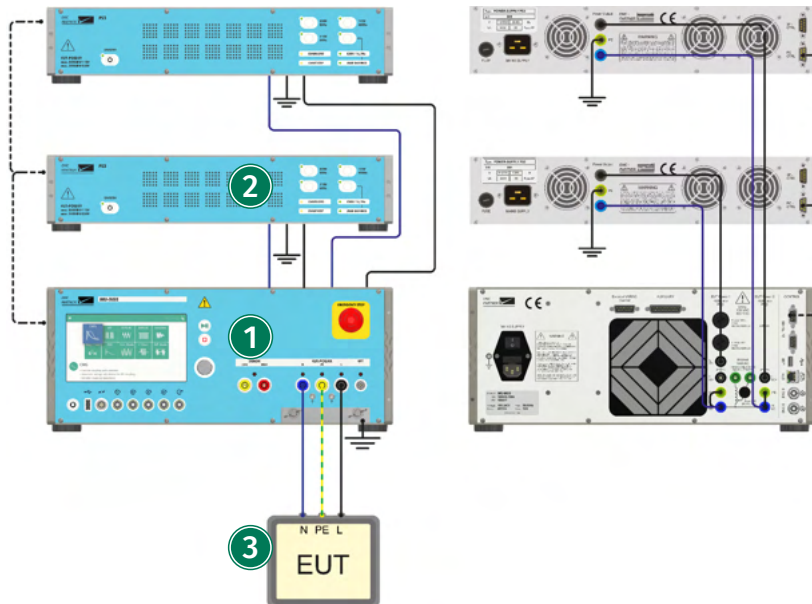

IMU-MGS or IMU-MGE - PS3 - RS485-RS232 ADAPTER

① Generator

On your IMU-MGS or IMU-MGE generator select the "DIPS DC" immunity test and set the test parameters according to your needs, in the (Coupling) menu tab set the "Device" to internal and "Source" to the employed source (Your own power supplies or the PS3). Your generator should be grounded.

② PS3

Two PS3 power supplies are required to generate two independent DC voltages for DC Dips tests. Connect both of them to the mains, connect the outputs of the first PS3 to the PWR1 inputs of your generator and the outputs of the second PS3 to the PWR2 inputs of your generator: Connect both to your generator via an RS485-RS232 ADAPTER.

③ Equipment Under Test (EUT)

Connect the EUT to the CDN output (EUT POWER) of your generator.

15.2 Calibration

15.2.1 Verification of DC Interrupts Inrush Currents and Switching Time

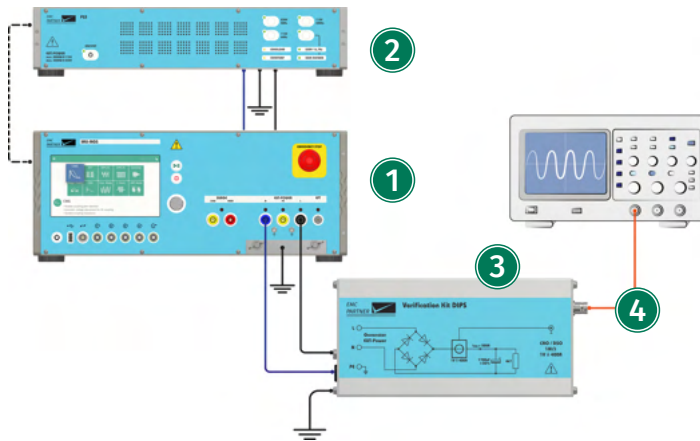

IMU-MGS or IMU-MGE - PS3 - RS485-RS232 ADAPTER - VERI-DIPS

1 Generator

On your IMU-MGS or IMU-MGE generator select the "DIPS DC" immunity test and set the test parameters, according to your needs, in the (Coupling) menu tab set the "Device" to internal and "Source" to the employed source (Your own power supply or the PS3). Your generator should be grounded.

2 PS3

A PS3 power supply is required to generate a DC voltage for DC Interrupts tests. Connect it to the mains, to the PWR1 inputs on the rear panel of your generator and to your generator via an RS485-RS232 ADAPTER.

3 Verification device VER-DIPS

Connect the VERI-DIPS verification device to the CDN power output (Line and Neutral) of your generator. The VERI-DIPS should be grounded.

4 CRO Output

Connect the BNC output on the VERI-DIPS to an oscilloscope with a 1 MOhm input impedance.

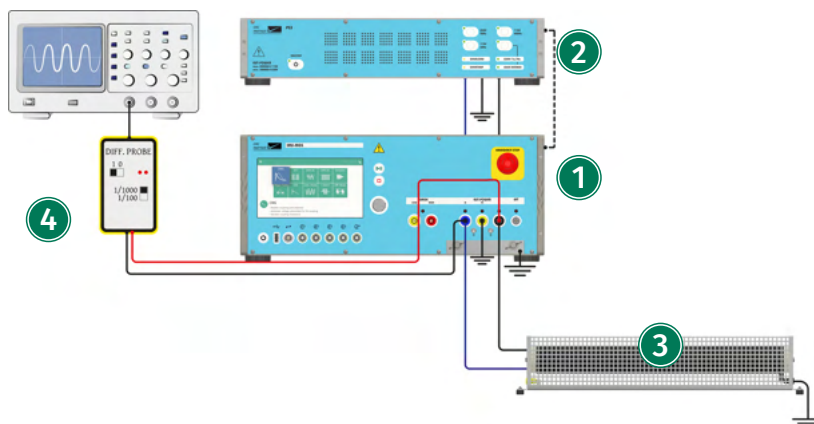

IMU-MGS or IMU-MGE - PS3 - RS485-RS232 ADAPTER - DIPS100E

1 Generator

On your IMU-MGS or IMU-MGE generator select the "DIPS DC" immunity test and set the test parameters according to your needs, in the (Coupling) menu tab set the "Device" to internal and "Source" to the employed source (Your own power supply or the PS3). Your generator should be grounded.

2 PS3

A PS3 power supply is required to generate a DC voltage for DC Interrupts tests. Connect it to the mains, to the PWR1 inputs on the rear panel of your generator and to your generator via an RS485-RS232 ADAPTER.

3 DIPS100E

Connect the 100 Ohm verification resistor DIPS100E to the EUT-POWER output, i.e. between Line and Neutral.

4 Measurement

Connect a differential probe with sufficient specifications, e.g. V-PROBE-SI, to the EUT-POWER output, i.e. between Line and Neutral.

15.2.2

Verification of DC Dips Inrush Current and Switching Time

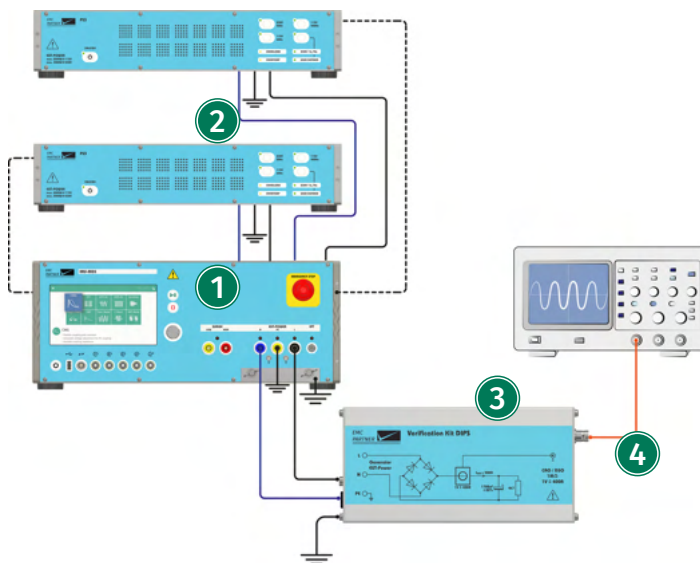

IMU-MGS or IMU-MGE - PS3 - RS485-RS232 ADAPTER - VERI-DIPS

1 Generator

On your IMU-MGS or IMU-MGE generator select the "DIPS DC" immunity test and set the test parameters according to your needs, in the (Coupling) menu tab set the "Device" to internal and "Source" to the employed source (Your own power supply or the PS3). Your generator should be grounded.

2 PS3

Two PS3 power supplies are required to generate two independent DC voltages for DC Dips tests. Connect both of them to the mains, connect the outputs of the first PS3 to the PWR1 inputs of

your generator and the outputs of the second PS3 to the PWR2 inputs of your generator: Connect both to your generator via an RS485-RS232 ADAPTER.

3 Verification device VER-DIPS

Connect the VERI-DIPS verification device to the CDN power output (Line and Neutral) of your generator. The VERI-DIPS should be grounded.

4 CRO Output

Connect the BNC output on the VERI-DIPS to an oscilloscope with a 1 MOhm input impedance.

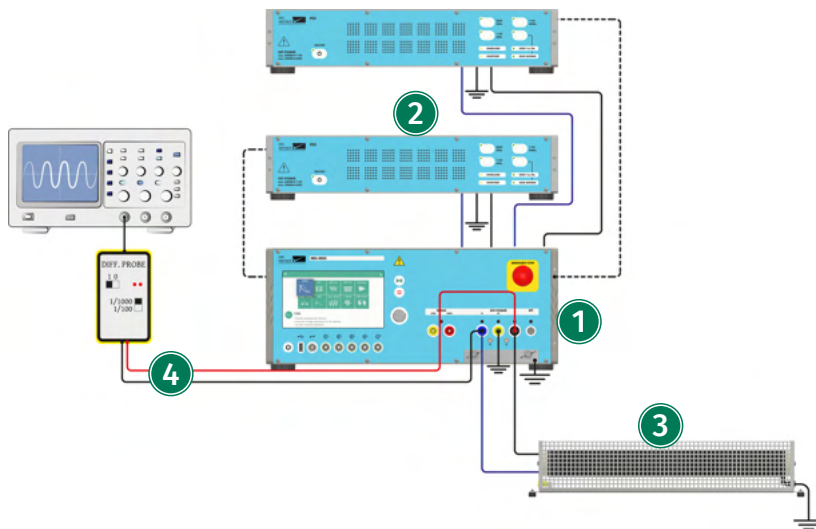

IMU-MGS or IMU-MGE - PS3 - RS485-RS232 ADAPTER - DIPS100E

1 Generator

On your IMU-MGS or IMU-MGE generator select the "DIPS DC" immunity test and set the test parameters according to your needs, in the (Coupling) menu tab set the "Device" to internal and "Source" to the employed source (Your own power supplies or the PS3). Your generator should be grounded.

2 PS3

Two PS3 power supplies are required to generate two independent DC voltages for DC Dips tests. Connect both of them to the mains, connect the outputs of the first PS3 to the PWR1 inputs of your generator and the outputs of the second PS3 to the PWR2 inputs of your generator: Connect both to your generator via an RS485-RS232 ADAPTER.

3 DIPS100E

Connect the 100 Ohm verification resistor DIPS100E to the EUT-POWER output, i.e. between Line and Neutral.

4 Measurement

Connect a differential probe with sufficient specifications, e.g. V-PROBE-SI, to the EUT-POWER output, i.e. between Line and Neutral.

- ② **Coupling Network CN16DC**
Connect the output of the generator to the the input of the CN16DC with a 1 m twisted pair cable. A connection to protective earth is also required.
- ③ **Auxiliary Connection**
Connect the auxiliary plugs between the generator and the CN16DC. Without this connection, the fans are unpowered and the EUT connection is interrupted.
- ④ **Power Supply PS3**
A power supply PS3 is used to generate the disturbance signals at DC and mains frequencies. It is connected to the mains via a standard power cable and to the generator via an RS485-RS232 adapter. All connections to the PS* are made on its rear panel.
- ⑤ **EXT-IMU C-SHORT**
The EXT-IMU C-SHORT is used to generate short disturbances as per IEC 61000-4-16 up to the maximal voltage levels provided in the chapter "??".
- ⑥ **Decoupling Network DN16-1P16**
A suitable decoupling element must be placed between the EUT and the auxiliary equipment. It prevents the test voltage applied to the EUT from affecting other devices, equipment or systems which are not under test. The appropriate decoupling element depends on the type of signal. Possible decoupling devices are for example isolation transformers, such as the DN16-1P16 shown here.
- ⑦ **Auxiliary Equipment (AE)**
Equipment that is necessary for setting up all functions and assessing the correct performance of the EUT during the test.
- ⑧ **Equipment Under Test (EUT)**
Equipment subjected to the disturbance signal, should be connected to the output port of the coupling network.

16.1.2 Common Mode Testing on 3 Power Lines

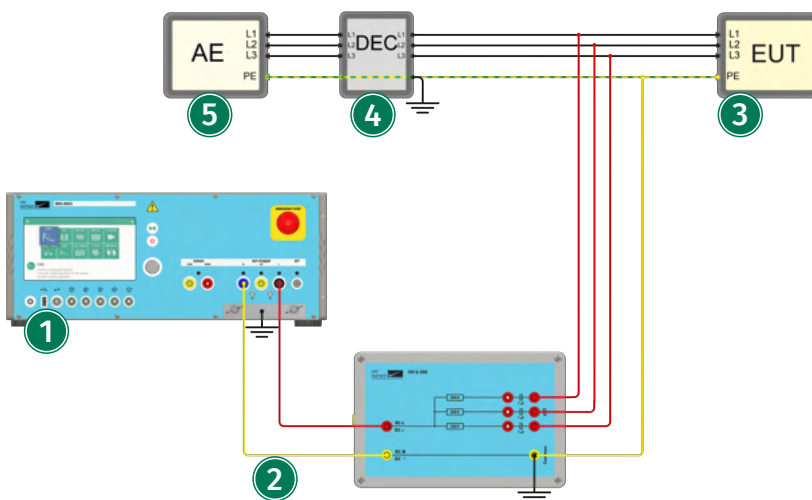

IMU-MGS or IMU-MGE - CN16-300

- 1 Generator**
The CN16-300 coupling network can be used together with EMC PARTNER generators IMU-MGS or IMU-MGE. The generator must be equipped with the common mode module EXT-IMU C. On your IMU-MGS or IMU-MGE generator select the "C Short" immunity test and set the test parameters, e.g. level, frequency, and time, according to your needs.
- 2 Coupling Network CN16-300**
Connect the output of the generator to the the input of the CN16-300 with a 1 m twisted pair cable. A connection to protective earth is also required.
- 3 Equipment Under Test (EUT)**
Connect the EUT to the CN16-300. For AC disturbance tests, the EUT is connected behind the coupling capacitors (as shown in the picture). For DC disturbance tests, the EUT is connected before the coupling capacitors.

 Due to the bypassed coupling capacitor, the maximum allowed EUT voltage is reduced during DC-disturbance tests. More information are available in chapter "technical specification".
- 4 Decoupling**
A suitable decoupling element must be placed between the EUT and the auxiliary equipment. It prevents the test voltage applied to the EUT from affecting other devices, equipment or systems which are not under test. The appropriate decoupling element depends on the type of signal. A possible decoupling device for this test is a three-phase isolation transformer.
- 5 Auxiliary Equipment (AE)**
Equipment that is necessary for setting up all functions and assessing the correct performance of the EUT during the test.

16.1.3

Common Mode Testing on up to 4 Power or Data Lines

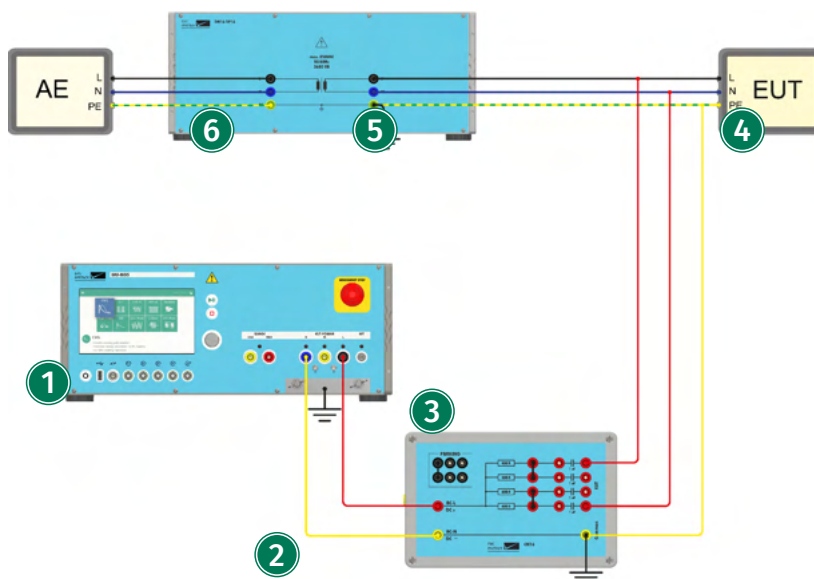

IMU-MGS or IMU-MGE - CN16 - DN16-1P16

1 Generator

The CN16 coupling network can be used together with EMC PARTNER generators IMU-MGS or IMU-MGE. The generator must be equipped with the common mode module EXT-IMU C. On your IMU-MGS or IMU-MGE generator select the "C Short" immunity test and set the test parameters, e.g. level, frequency, and time, according to your needs.

2 Coupling Network CN16

Connect the output of the generator to the the input of the CN16 with a 1 m twisted pair cable. A connection to protective earth is also required.

3 Coupling Lines

The needed coupling resistance for each line depends on the total amount of coupled lines. It is 100 Ohm multiplied by the total amount of lines. With the bridges, lines can be connected in parallel to adjust the resistance.

- For 4 lines: each line individually
- For 2 lines: 2 times 2 lines in parallel as shown on the picture
- For 1 line: all 4 lines in parallel



Unused bridges can be stored in the parking position.

4 Equipment Under Test (EUT)

Connect the EUT to the CN16. For AC disturbance tests, the EUT is connected behind the coupling capacitors (as shown in the picture). For DC disturbance tests, the EUT is connected before the coupling capacitor.



Due to the bypassed coupling capacitor, the maximum allowed EUT voltage is reduced during DC-disturbance tests. More information are available in chapter "technical specification".

5 Decoupling

A suitable decoupling element must be placed between the EUT and the auxiliary equipment. It prevents the test voltage applied to the EUT from affecting other devices, equipment or systems which are not under test. The appropriate decoupling element depends on the type of signal. Possible decoupling devices are opto-isolators or isolation transformers.



For disturbance tests on 1 phase ac power lines, the DN16-1P6 or DN16-1P16 can be used as decoupling element.

6 Auxiliary Equipment (AE)

Equipment that is necessary for setting up all functions and assessing the correct performance of the EUT during the test.

16.1.4 Common Mode Testing on up to 8 Power or Data Lines

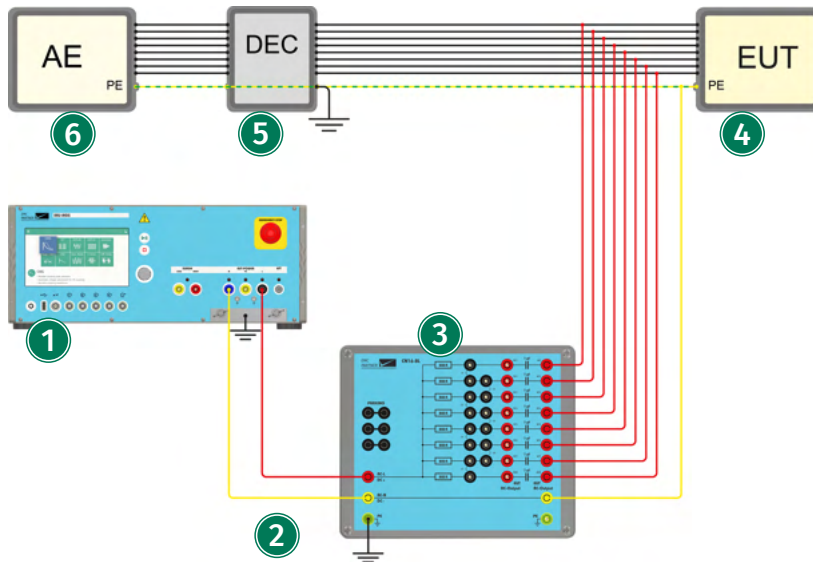

IMU-MGS or IMU-MGE - CN16-8L

1 Generator

The CN16-8L coupling network can be used together with EMC PARTNER generators IMU-MGS or IMU-MGE. The generator must be equipped with the common mode module EXT-IMU C. On your IMU-MGS or IMU-MGE generator select the "C Short" immunity test and set the test parameters, e.g. level, frequency, and time, according to your needs.

2 Coupling Network CN16-8L

Connect the output of the generator to the the input of the CN16-8L with a 1m twisted pair cable. A connection to protective earth is also required.

3 Coupling Lines

The needed coupling resistance for each line depends on the total amount of coupled lines. It is 100 ohm multiplied by the total amount of lines. With the bridges, the lines can be connected in parallel to adjust the resistance.

- For 8 lines: each line individually as shown on the picture
- For 4 lines: 4 times 2 lines in parallel (bridge L1, L3, L5 and L7)
- For 2 lines: 2 times 4 lines in parallel (bridge L1, L2, L3, L5, L6 and L7)
- For 1 line: all 8 lines in parallel (bridge L1, L2, L3, L4, L5, L6 and L7)



Unused bridges can be stored in the parking position.

4 Equipment Under Test (EUT)

Connect the EUT to the CN16-8L. For AC disturbance tests, the EUT is connected behind the coupling capacitors (outputs AC1 to AC8, as shown in the picture). For DC disturbance tests, the EUT is connected before the coupling capacitor (outputs DC1 to DC8).



Due to the bypassed coupling capacitor, the maximum allowed EUT voltage is reduced during DC-disturbance tests. More information are available in the chapter "technical specifications".

5 Decoupling

A suitable decoupling element must be placed between the EUT and the auxiliary equipment. It prevents the test voltage applied to the EUT from affecting other devices, equipment or systems which are not under test. The appropriate decoupling element depends on the type of signal. Possible decoupling devices are for example opto-isolators or isolation transformers.



For disturbance tests on 1 phase ac power lines, the DN16-1P6 or DN16-1P16 can be used as decoupling element.

6 Auxiliary Equipment (AE)

Equipment that is necessary for setting up all functions and assessing the correct performance of the EUT during the test.

16.1.5 Common Mode Testing on 1 Balanced Data Line Pair

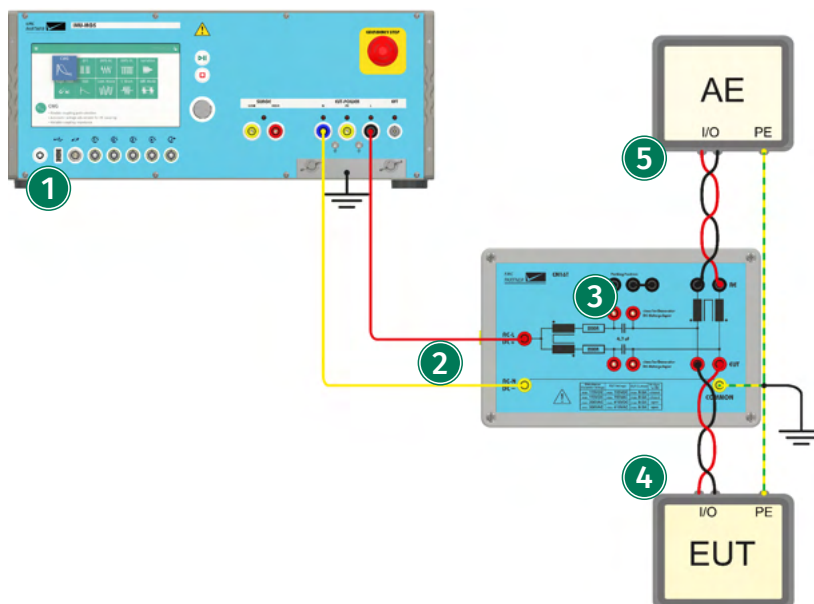

IMU-MGS or IMU-MGE - CN16T

1 Generator

The CN16T coupling network can be used together with EMC PARTNER generators IMU-MGS or IMU-MGE. The generator must be equipped with the common mode module EXT-IMU C. On your IMU-MGS or IMU-MGE generator select the "Common Mode" or "C Short" immunity test and set the test parameters, e.g. level, frequency, and time, according to your needs.

2 Coupling Network CN16T

Connect the output of the generator to the the input of the CN16T with a 1 m twisted pair cable. A connection to protective earth is also required.

3 Coupling Capacitor

For DC-disturbance tests, the all coupling capacitor must be bypassed with the MC-bridge. For AC-Disturbance tests, the bridges can be stored in the parking position.



Due to the bypassed coupling capacitor, the maximum allowed EUT voltage is reduced during DC-disturbance tests. More information are available in chapter "technical specification".

4 Equipment Under Test (EUT)

Connect the EUT to the CN16T. The decoupling element is integrated in the CN16T.

5 Auxiliary Equipment (AE)

Equipment that is necessary for setting up all functions and assessing the correct performance of the EUT during the test.

16.1.6

Common Mode Testing on 2 Balanced Data Line Pairs

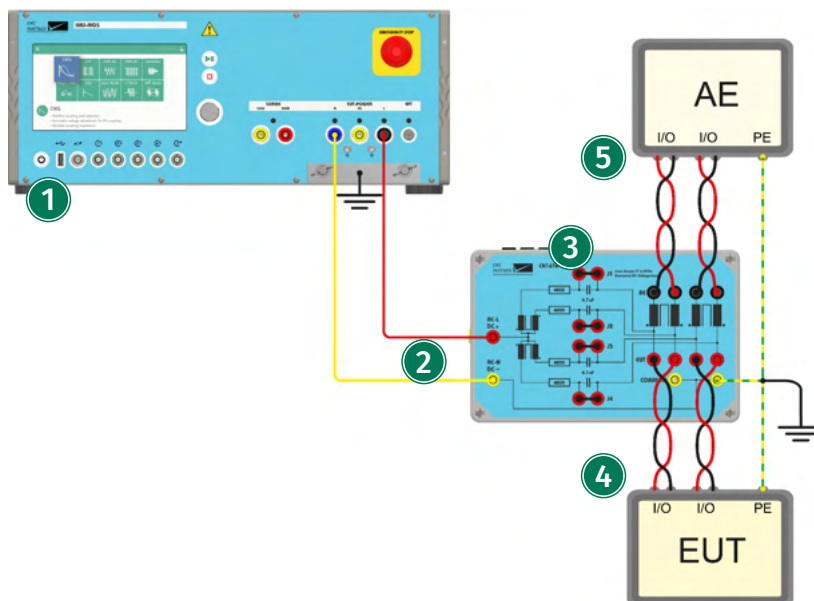

IMU-MGS or IMU-MGE - CN16T4

1 Generator

The CN16T4 coupling network can be used together with EMC PARTNER generators IMU-MGS or IMU-MGE. The generator must be equipped with the common mode module EXT-IMU C. On your IMU-MGS or IMU-MGE generator select the "Common Mode" or "C Short" immunity test and set the test parameters, e.g. level, frequency, and time, according to your needs.

2 Coupling Network CN16T4

Connect the output of the generator to the the input of the CN16T4 with a 1 m twisted pair cable. A connection to protective earth is also required.

3 Coupling Capacitor

For DC-disturbance tests, the all coupling capacitor must be bypassed with the MC-bridge. For AC-Disturbance tests, the bridges can be stored in the parking position.



Due to the bypassed coupling capacitor, the maximum allowed EUT voltage is reduced during DC-disturbance tests. More information are available in chapter "technical specification".

4 Equipment Under Test (EUT)

Connect the EUT to the CN16T4. The decoupling element is integrated in the CN16T4.

5 Auxiliary Equipment (AE)

Equipment that is necessary for setting up all functions and assessing the correct performance of the EUT during the test.

16.1.7

Common Mode Testing on 4 Balanced Data Line Pairs

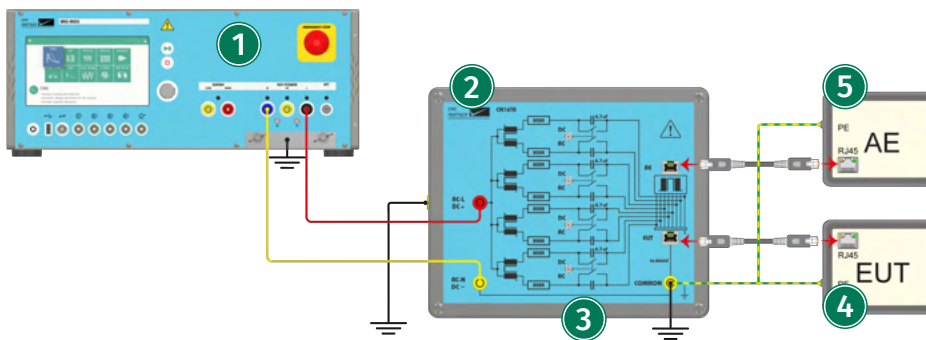

IMU-MGS or IMU-MGE - CN16T8

1 Generator

The CN16T8 coupling network can be used together with EMC PARTNER generators IMU-MGS or IMU-MGE. The generator must be equipped with the common mode module EXT-IMU C. On your IMU-MGS or IMU-MGE generator select the "Common Mode" or "C Short" immunity test and set the test parameters, e.g. level, frequency, and time, according to your needs.

2 Coupling Network CN16T8

Connect the output of the generator to the the input of the CN16T8 with a 1 m twisted pair cable. A connection to protective earth is also required.

3 Coupling Capacitor

For DC-disturbance tests, the all coupling capacitor must be bypassed putting the four toggle switches in the DC position. For AC-Disturbance tests, the coupling capacitors should be used and the toggle switches be placed in the AC position.



Due to the bypassed coupling capacitor, the maximum allowed EUT voltage is reduced during DC-disturbance tests. More information are available in chapter "technical specification".

4 Equipment Under Test (EUT)

Connect the EUT to the CN16T8. The decoupling element is integrated in the CN16T8.

5 Auxiliary Equipment (AE)

Equipment that is necessary for setting up all functions and assessing the correct performance of the EUT during the test.

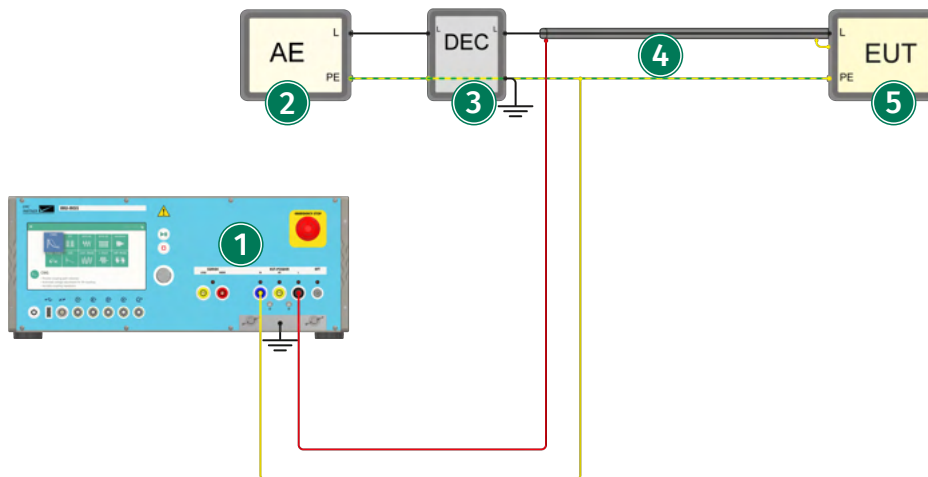
16.1.8 Common Mode Testing on Shielded Cables

IMU-MGS or IMU-MGE

1 Generator

The generator must be equipped with the common mode module EXT-IMU C. On your IMU-MGS or IMU-MGE generator select the "Common Mode" or "C Short" immunity test and set the test parameters, e.g. level, frequency, and time, according to your needs.

2 Auxiliary Equipment (AE)

Equipment that is necessary for setting up all functions and assessing the correct performance of the EUT during the test.

3 Decoupling Device

A suitable decoupling element can be placed between the EUT and the auxiliary equipment. It prevents the test voltage applied to the EUT from affecting other devices, equipment or systems which are not under test. The appropriate decoupling element depends on the type of signal.

4 Shielded Cable

The generator output is connected directly to the screen (shield) of the (coaxial) cable. No additional series resistors or coupling capacitors are required.

5 Equipment Under Test (EUT)

16.1.9

Disturbance Testing on 2 Lines as per IEC 60255-22-7/-26

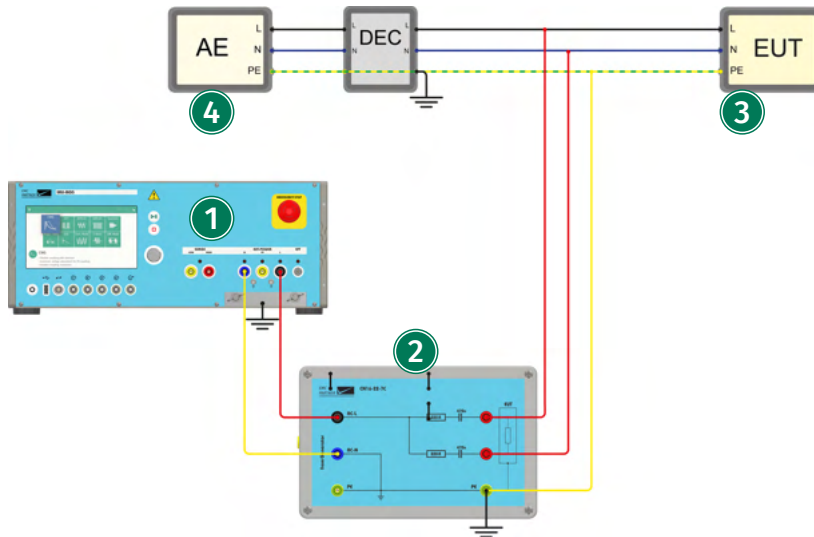

IMU-MGS or IMU-MGE - CN16-22-7C

1 Generator

The CN16-22-7C coupling network can be used together with EMC PARTNER generators IMU-MGS or IMU-MGE. The generator must be equipped with the common mode module EXT-IMU C. On your IMU-MGS or IMU-MGE generator select the "Common Mode" or "C Short" immunity test and set the test parameters, e.g. level, frequency, and time, according to your needs.

2 Coupling Network CN16-22-7C

Connect the output of the generator to the the input of the CN16-22-7C with a 1 m twisted pair cable. A connection to protective earth is also required.

3 Equipment Under Test (EUT)

Connect the equipment under test to the output of the CN16-22-7C coupling network.

4 Auxiliary Equipment (AE)

Equipment that is necessary for setting up all functions and assessing the correct performance of the EUT during the test.

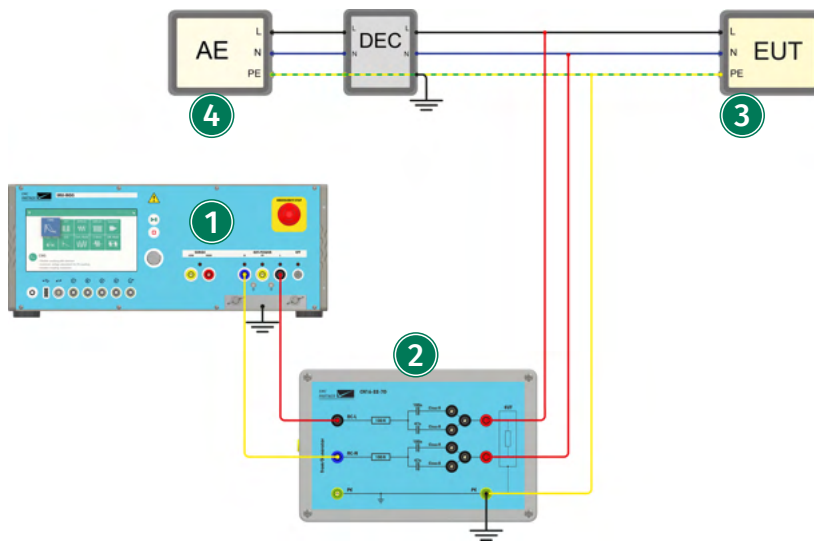

IMU-MGS or IMU-MGE - CN16-22-7D

1 Generator

The CN16-22-7D coupling network can be used together with EMC PARTNER generators IMU-MGS or IMU-MGE. The generator must be equipped with the common mode module EXT-IMU C. On your IMU-MGS or IMU-MGE generator select the "Common Mode" or "C Short" immunity test and set the test parameters, e.g. level, frequency, and time, according to your needs.

2 Coupling Network CN16-22-7D

Connect the output of the generator to the the input of the CN16-22-7D with a 1 m twisted pair cable. A connection to protective earth is also required.

3 Equipment Under Test (EUT)

Connect the equipment under test to the output of the CN16-22-7D coupling network.

4 Auxiliary Equipment (AE)

Equipment that is necessary for setting up all functions and assessing the correct performance of the EUT during the test.

16.2

Calibration

16.2.1

Calibration of the CDN Output

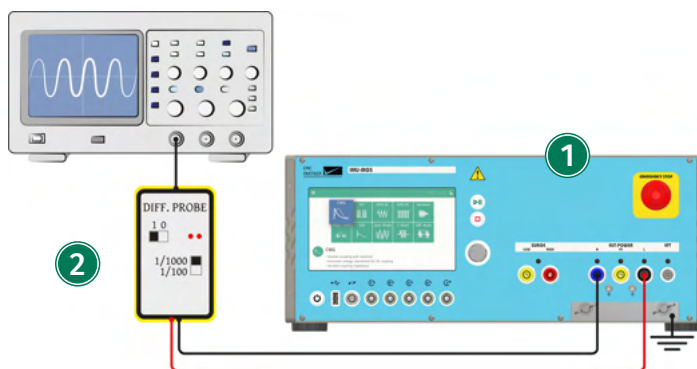

IMU-MGS or IMU-MGE - V-PROBE-SI

1 Generator

On your IMU-MGS or IMU-MGE generator select the "Common Mode" immunity test and set the test parameters, e.g. level, frequency, and time, according to your needs.

2 Measurement

Connect a voltage probe with sufficient specifications, e.g. V-PROBE-SI, or an appropriate voltage meter to the CDN output of your generator.

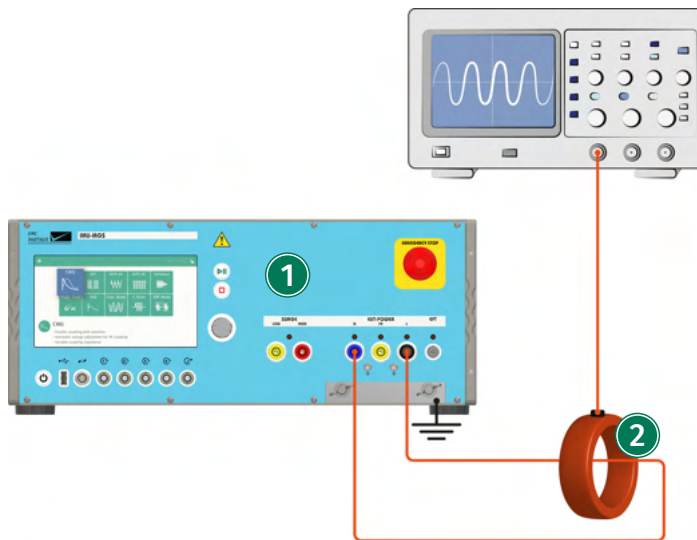

IMU-MGS or IMU-MGE - I-PROBE-P101

1 Generator

On your IMU-MGS or IMU-MGE generator select the "Common Mode" immunity test and set the test parameters, e.g. level, frequency, and time, according to your needs.

2 Measurement

Connect a current probe with sufficient specifications, e.g. I-PROBE-P101, or an appropriate current meter to the CDN output of your generator. DC current measurements should be carried out with a current meter.

16.2.2 Calibration of the EXT-IMU C-SHORT

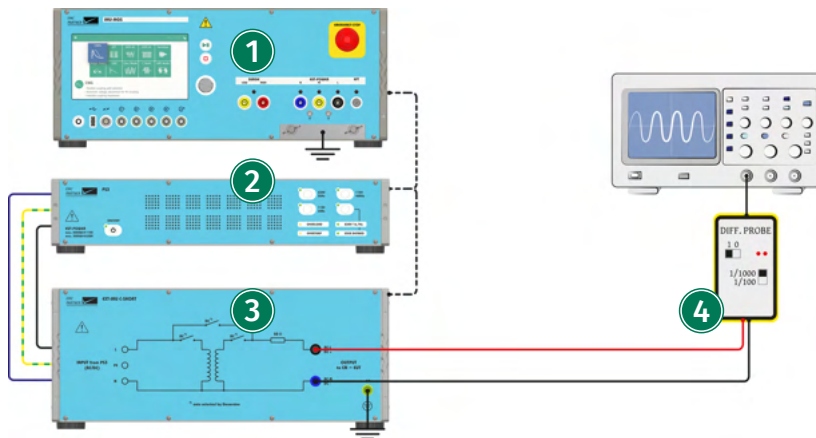

IMU-MGS or IMU-MGE - PS3 - RS485-RS232 ADAPTER - EXT-IMU C-SHORT - V-PROBE-SI

- 1 **Generator**
On your IMU-MGS or IMU-MGE generator select the "C Short" immunity test and set the test parameters, e.g. level, frequency, and time, according to your needs and set the serial number of your PS3
- 2 **PS3**
A PS3 power supply is required for Common Mode short tests. Connect it to the mains and to your generator via an RS485-RS232 ADAPTER.
- 3 **EXT-IMU C-SHORT**
Connect the EXT-IMU C-SHORT power input to the power output of the PS3. All connections are made on the rear panels. Connect the EXT-IMU-SHORT to your generator via a RS485-RS232 ADAPTER.
- 4 **Measurement**
Connect a voltage probe with sufficient specifications, e.g. V-PROBE-SI, or an appropriate voltage meter to the output of the EXT-IMU C-SHORT.

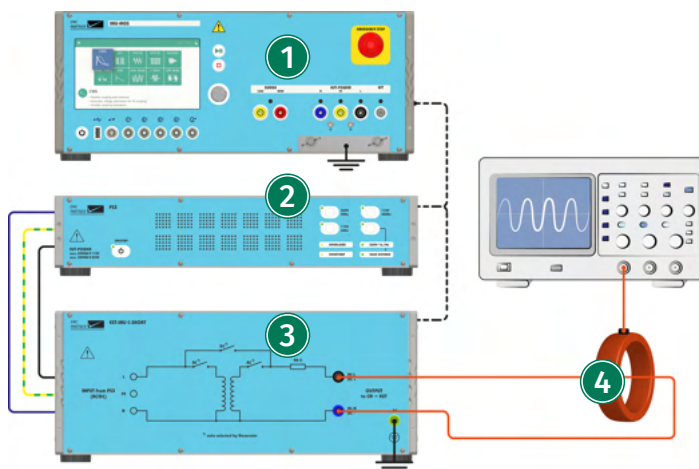

IMU-MGS or IMU-MGE - PS3 - RS485-RS232 ADAPTER - EXT-IMU C-SHORT - I-PROBE-P101

1 Generator

On your IMU-MGS or IMU-MGE generator select the "C Short" immunity test and set the test parameters, e.g. level, frequency, and time, according to your needs and set the serial number of your PS3

2 PS3

A PS3 power supply is required for Common Mode short tests. Connect it to the mains and to your generator via an RS485-RS232 ADAPTER.

3 EXT-IMU C-SHORT

Connect the EXT-IMU C-SHORT power input to the power output of the PS3. All connections are made on the rear panels. Connect the EXT-IMU-SHORT to your generator via a RS485-RS232 ADAPTER.

4 Measurement

Connect a current probe with sufficient specifications, e.g. I-PROBE-P101, or an appropriate current meter to the output of the EXT-IMU C-SHORT.

17 Tests as per IEC 61000-4-19: Differential Mode

This chapter provides information on generator calibration and verification as well as on testing setups for immunity tests according to the latest edition of IEC 61000-4-5: "Testing and measurement techniques - Test for immunity to conducted, differential mode disturbances and signaling in the frequency range 2 kHz to 150 kHz at AC power ports".



To perform these tests your IMU-MGS or IMU-MGE generator must be equipped with one of the following extensions:

- IMU SLAVE SMART I1V1
- IMU SLAVE SMART I1
- IMU SLAVE SMART V1



IMU SLAVE SMART I1 provides the capabilities of current tests only and IMU SLAVE SMART V1 provides the capabilities of the voltage test only. IMU SLAVE SMART I1V1 combines both tests in one device. In the following pictures, always IMU SLAVE SMART I1V1 is shown, even though only either I1 or V1 parts are needed.

17.1 Hardware Description

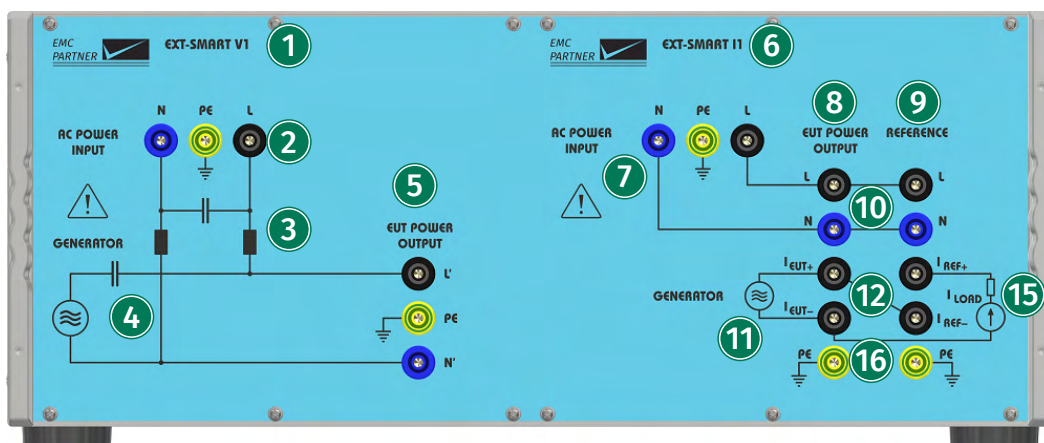

- ① **IMU SLAVE SMART V1**
IMU SLAVE SMART V1 for differential mode voltage immunity tests. If this part is not fitted, the left half of the device is empty.
- ② **AC Power Input**
Input connectors for AC power (N,PE,L)
- ③ **Internal CDN**
Internal coupling-decoupling network (CDN) to couple the generator disturbances on the EUT, and decouple the mains input.
- ④ **Voltage Disturbance Generator**
Internal disturbance source (including coupling capacitor) to generate differential mode voltage disturbances in the frequency range 2 kHz-15 kHz and levels as specified in the chapter "??".
- ⑤ **EUT Power Output**
Output connectors for the equipment under test.

- ⑥ **IMU SLAVE SMART I1**
IMU SLAVE SMART I1 for differential mode current immunity tests. If this part is not fitted, the right half of the device is empty.
- ⑦ **AC Power Input**
Input connectors for AC power (N,PE,L)
- ⑧ **EUT Outputs**
Output row for connecting the equipment under test (EUT)
- ⑨ **REF Outputs**
Output row to connect an optional reference equipment (REF) not subjected to disturbances, for direct comparison with the EUT.
- ⑩ **EUT and REF Voltage Outputs**
Voltage connectors (L and N) for the EUT and REF.
- ⑪ **Current Disturbance Generator**
Internal disturbance source to generate differential mode current disturbances in the frequency range 2 kHz-15 kHz and levels as specified in the chapter "??".
- ⑫ **EUT and REF Current Outputs**
Current connectors for the EUT and REF. In case no RE is used, these two connectors should be short-circuited with a bridge connector.
- ⑬ **Load Current Source**
Internal load current source.
In addition to the disturbance generator for current disturbances 2 kHz-150 kHz, IMU SLAVE SMART I1 is equipped with a reference current source, the CS25, to provide an accurate and reliable load current together with a decoupling impedance in order to decouple the load current generator from the disturbance generator. The technical specifications of the current source are provided in the chapter "??". When you want to employ your own current source, you can connect it to the external current source inputs on the rear panel of the IMU SLAVE SMART.
- ⑭ **PE Connections**
Ground connectors for the EUT and RE.

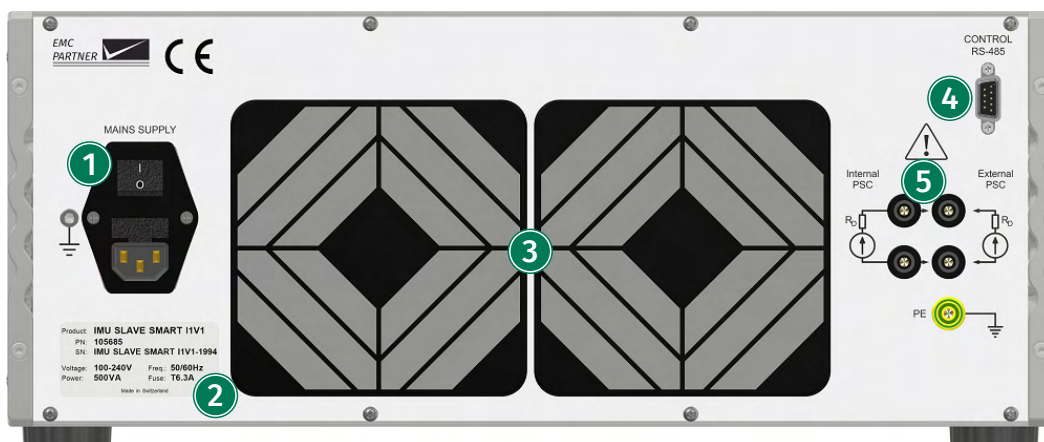

① Mains Supply

A country specific mains cable is delivered with the equipment, this should be used to connect to the mains power supply. A mains fuse is located in the socket housing. The value is indicated on the equipment type plate.



Take care to ensure the power main matches the power ratings on the equipment type plate.

The generator must always be connected to protective earth.

② Device information Panel

Product name, serial number (SN), product number (PN), and input power requirements.

③ Rear Fans

Rear cooling fans. Take care not to obstruct the opening to assure proper airflow through the generator and prevent overheating.

④ RS485 Interface

Interface to connect the IMU SLAVE SMART to your IMU-MGS or IMU-MGE generator.

⑤ Load Current Source Connections

When the internal load current generator is used, connection bridges should be placed on these connectors in order to connect the (Internal PSC) outputs and the (External PSC) inputs. When you wish to employ your own load current source, connect it to the two connectors on the right side (External PSC).

17.2

Immunity Tests

17.2.1

Current immunity test



In addition to the disturbance generator for current disturbances 2 kHz-150 kHz, IMU SLAVE SMART I1 is equipped with a reference current source, the CS25, to provide an accurate and reliable load current together with a decoupling impedance in order to decouple the load current generator from the disturbance generator. The technical specifications of the current source are provided in the chapter "??".



When you want to employ your own current source, you can connect it to the external current source inputs on the rear panel of the IMU SLAVE SMART. When you want to employ the built-in current source, two bridges must be placed on these inputs.

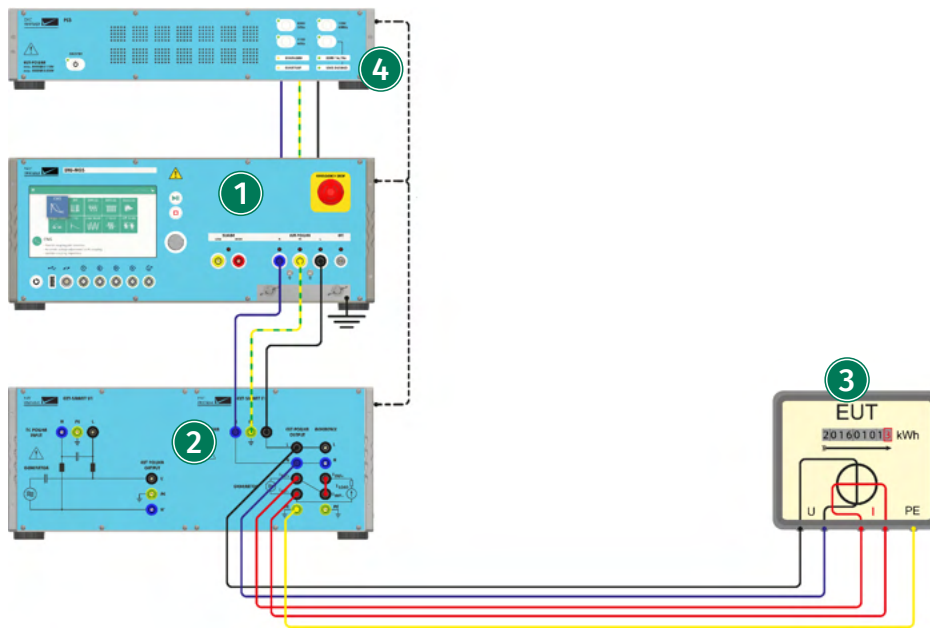

IMU-MGS or IMU-MGE - IMU SLAVE SMART I1V1 - optional PS3 with RS485-RS232 ADAPTER

1 Generator

On your IMU-MGS or IMU-MGE generator select the "Differential Mode" immunity test and set the "Test Type" to Current. Set all the other test parameters, e.g. wave profile, levels and timing, according to your needs.

2 IMU SLAVE SMART

For the current test, only the IMU SLAVE SMART I1 (right side) is needed. Connect the EUT POWER output (L,N,PE) of the generator to the AC POWER INPUT (L,N,PE) of the SLAVE SMART I1.

3 Equipment under test (EUT)

Connect the voltage interface of the EUT (L and N) to the EUT power output (L and N) of IMU SLAVE SMART I1. Connect the EUT ground to the PE output on the IMU SLAVE SMART I1. Connect the EUT current interface (current measurement probe or shunt) between the I_{EUT+} and I_{EUT-} outputs on the IMU SLAVE SMART I1.

If no reference device is employed in the test setup place a bridge between the I_{REF+} and I_{REF-} connectors on the front panel.

4 PS3 (optional)

You can supply the generator via a PS3 power supply, connected to the PWR1 inputs on the rear panel and connected via a RS485-RS232 ADAPTER. Alternatively you can also connect IMU SLAVE SMART directly to your mains power or another single-phase power supply.

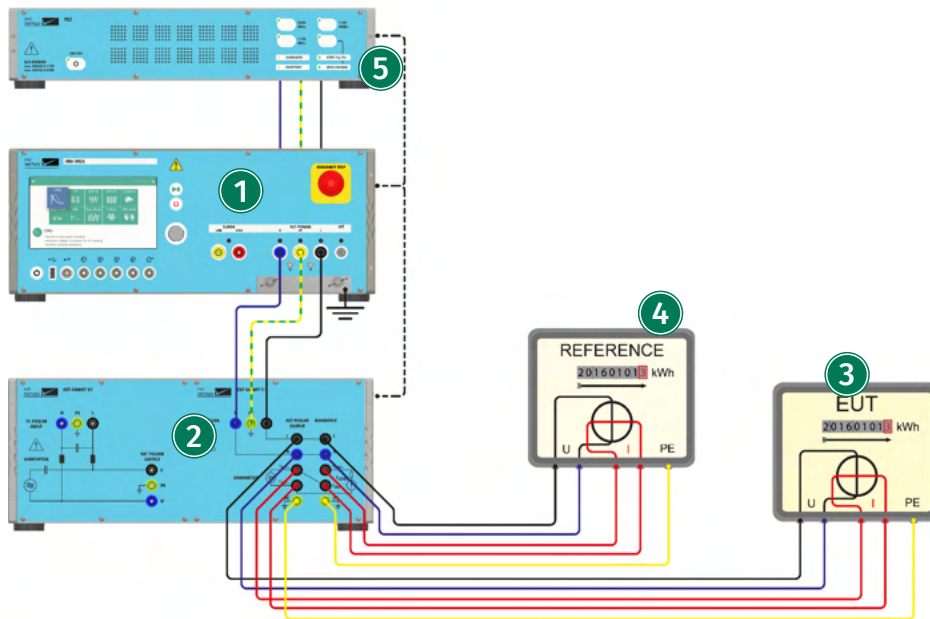

IMU-MGS or IMU-MGE - IMU SLAVE SMART I1V1 - optional PS3 with RS485-RS232 ADAPTER

1 Generator

On your IMU-MGS or IMU-MGE generator select the "Differential Mode" immunity test and set the "Test Type" to Current. Set all the other test parameters, e.g. wave profile, levels and timing, according to your needs.

2 IMU SLAVE SMART

For the current test, only the IMU SLAVE SMART I1 (right side) is needed. Connect the EUT POWER output (L,N,PE) of the generator to the AC POWER INPUT (L,N,PE) of the SLAVE SMART I1.

3 Equipment under test (EUT)

Connect the voltage interface of the EUT (L and N) to the EUT power output (L and N) of IMU SLAVE SMART I1. Connect the EUT ground to the PE output on the IMU SLAVE SMART I1. Connect the EUT current interface (current measurement probe or shunt) between the I_{EUT+} and I_{EUT-} outputs on the IMU SLAVE SMART I1.

4 Reference

IMU SLAVE SMART I1 allows you to connect a reference equipment to allow a direct comparison the the equipment under test. Connect it in the same way to the IMU SLAVE SMART I1 than the EUT, but to the REF outputs:

Connect the voltage interface of the REF (L and N) to the RE power output (L and N) of IMU SLAVE SMART I1. Connect the RE ground to the PE output on the IMU SLAVE SMART I1. Connect the EUT current interface (current measurement probe or shunt) between the I_{REF+} and I_{REF-} outputs on the IMU SLAVE SMART I1.

4 PS3 (optional)

You can supply the generator via a PS3 power supply, connected to the PWR1 inputs on the rear panel and connected via a RS485-RS232 ADAPTER. Alternatively you can also connect IMU SLAVE SMART directly to your mains power or another single-phase power supply.



Some EUTs do not possess four completely separate inputs for voltage, i.e. L and N, and current, e.g. I_{in} and I_{out} , but instead have three inputs with a common input for L and I_{in} . In that case the test setups and connection diagrams are as follows.

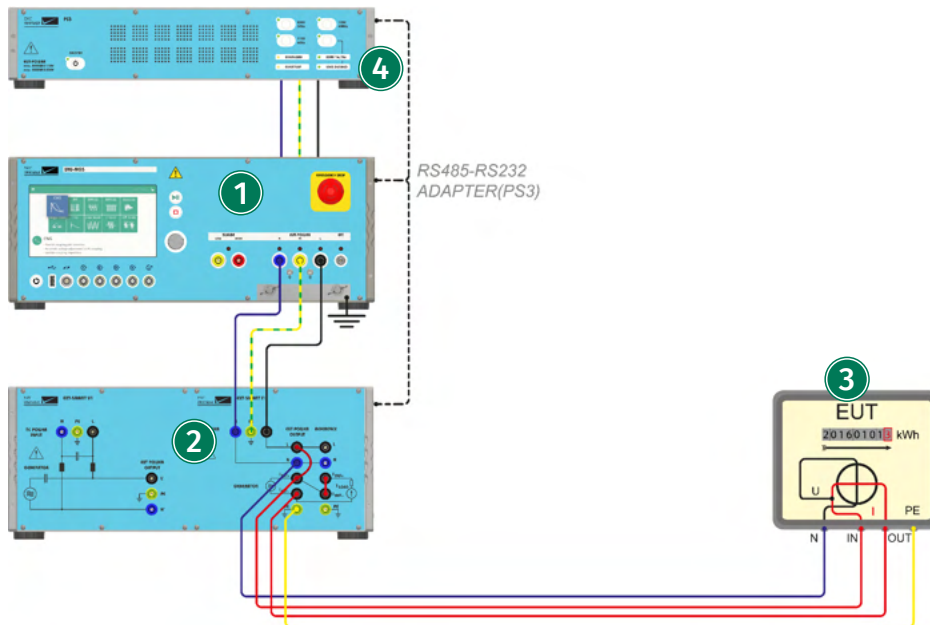

IMU-MGS or IMU-MGE - IMU SLAVE SMART I1V1 - optional PS3 with RS485-RS232 ADAPTER

1 Generator

On your IMU-MGS or IMU-MGE generator select the "Differential Mode" immunity test and set the "Test Type" to Current. Set all the other test parameters, e.g. wave profile, levels and timing, according to your needs.

2 IMU SLAVE SMART

For the current test, only the IMU SLAVE SMART I1 (right side) is needed. Connect the EUT POWER output (L,N,PE) of the generator to the AC POWER INPUT (L,N,PE) of the SLAVE SMART I1.

3 Equipment under test (EUT)

Connect the EUT ground to the PE output on the IMU SLAVE SMART I1. Connect the EUT current interface (current measurement probe or shunt) between the I_{EUT+} and I_{EUT-} outputs on the IMU SLAVE SMART I1. Connect the Neutral input of the EUT to the EUT power output N of the SLAVE SMART I1 and the EUT power output L to the I_{REF+} output using a short cable.

If no reference device is employed in the test setup place a bridge between the I_{REF+} and I_{REF-} connectors on the front panel.

4 PS3 (optional)

You can supply the generator via a PS3 power supply, connected to the PWR1 inputs on the rear panel and connected via a RS485-RS232 ADAPTER. Alternatively you can also connect IMU SLAVE SMART directly to your mains power or another single-phase power supply.

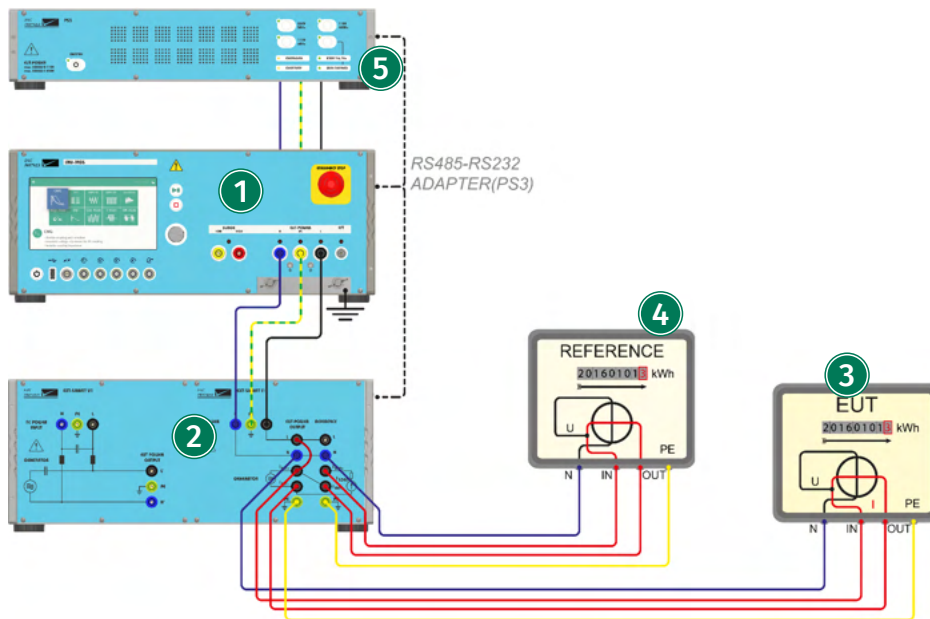

IMU-MGS or IMU-MGE - IMU SLAVE SMART I1V1 - optional PS3 with RS485-RS232 ADAPTER

1 Generator

On your IMU-MGS or IMU-MGE generator select the "Differential Mode" immunity test and set the "Test Type" to Current. Set all the other test parameters, e.g. wave profile, levels and timing, according to your needs.

2 IMU SLAVE SMART

For the current test, only the IMU SLAVE SMART I1 (right side) is needed. Connect the EUT POWER output (L,N,PE) of the generator to the AC POWER INPUT (L,N,PE) of the SLAVE SMART I1.

3 Equipment under test (EUT)

Connect the EUT ground to the PE output on the IMU SLAVE SMART I1. Connect the EUT current interface (current measurement probe or shunt) between the I_{EUT+} and I_{EUT-} outputs on the IMU SLAVE SMART I1. Connect the Neutral input of the EUT to the EUT power output N of the SLAVE SMART I1 and the EUT power output L to the I_{REF+} output using a short cable.

4 Reference

IMU SLAVE SMART I1 allows you to connect a reference equipment to allow a direct comparison the the equipment under test. Connect it in the same way to the IMU SLAVE SMART I1 than the EUT, but to the REF Connect the RE ground to the PE output on the IMU SLAVE SMART I1. Connect the EUT current interface (current measurement probe or shunt) between the I_{REF+} and I_{REF-} outputs on the IMU SLAVE SMART I1 and the neutral input of the reference equipment to the EUT power output N.

4 PS3 (optional)

You can supply the generator via a PS3 power supply, connected to the PWR1 inputs on the rear panel and connected via a RS485-RS232 ADAPTER. Alternatively you can also connect IMU SLAVE SMART directly to your mains power or another single-phase power supply.

17.2.2 Voltage immunity test

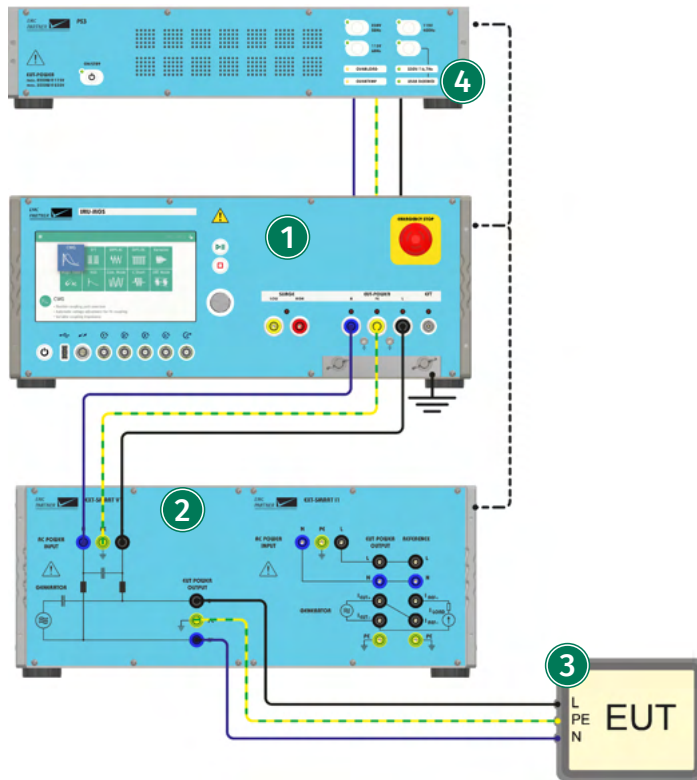

IMU-MGS or IMU-MGE - IMU SLAVE SMART I1V1 - optional PS3 with RS485-RS232 ADAPTER

- 1 Generator**
On your IMU-MGS or IMU-MGE generator select the "Differential Mode" immunity test and set the "Test Type" to Voltage. Set all the other test parameters, e.g. wave profile, levels and timing, according to your needs.
- 2 IMU SLAVE SMART**
Connect the EUT POWER outputs (L,N,PE) of the generator to the AC POWER INPUT (L,N,PE) on the front panel of the IMU SLAVE SMART V1.
- 3 Equipment under test (EUT)**
Connect the EUT to the EUT POWER OUTPUT (L',N',PE) on the front panel of the IMU SLAVE SMART V1.
- 4 PS3 (optional)**
You can supply the generator via a PS3 power supply, connected to the PWR1 inputs on the rear panel and connected via a RS485-RS232 ADAPTER. Alternatively you can also connect IMU SLAVE SMART directly to your mains power or another single-phase power supply.

17.3 Calibration

17.3.1 Calibration of current test

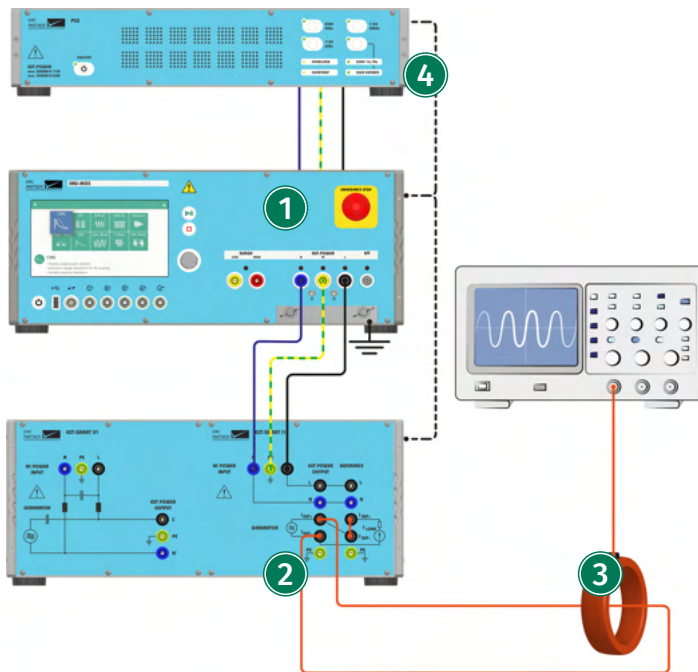

IMU-MGS or IMU-MGE - IMU SLAVE SMART I1V1 - optional PS3 with RS485-RS232 ADAPTER

1 Generator

On your IMU-MGS or IMU-MGE generator select the "Differential Mode" immunity test and set the "Test Type" to Current. Set all the other test parameters, e.g. wave profile, levels, and timing, according to your needs.

2 IMU SLAVE SMART

For the current test, only the IMU SLAVE SMART I1 (right side) is needed. Connect the EUT POWER output (L,N,PE) of the generator to the AC POWER INPUT (L,N,PE) of the SLAVE SMART I1. For calibration, place a bridge between the I_{REF+} and I_{REF-} connectors on the front panel.

3 Measurement

Connect a current probe with sufficient specifications, e.g. I-PROBE-P101, between the I_{EUT+} and I_{EUT-} outputs of the IMU SLAVE SMART I1.

4 PS3 (optional)

You can supply the generator via a PS3 power supply, connected to the PWR1 inputs on the rear panel and connected via a RS485-RS232 ADAPTER. Alternatively you can also connect IMU SLAVE SMART directly to your mains power or another single-phase power supply.



In addition to the disturbance generator for current disturbances 2 kHz-150 kHz, IMU SLAVE SMART I1 is equipped with a reference current source, the CS25, to provide an accurate and reliable load current together with a decoupling impedance in order to decouple the load current generator from the disturbance generator. The technical specifications of the current source are provided in the chapter "??".



When you want to employ your own current source, you can connect it to the external current source inputs on the rear panel of the IMU SLAVE SMART. When you want to employ the built-in current source, two bridges must be placed on these inputs.

17.3.2 Calibration of voltage test

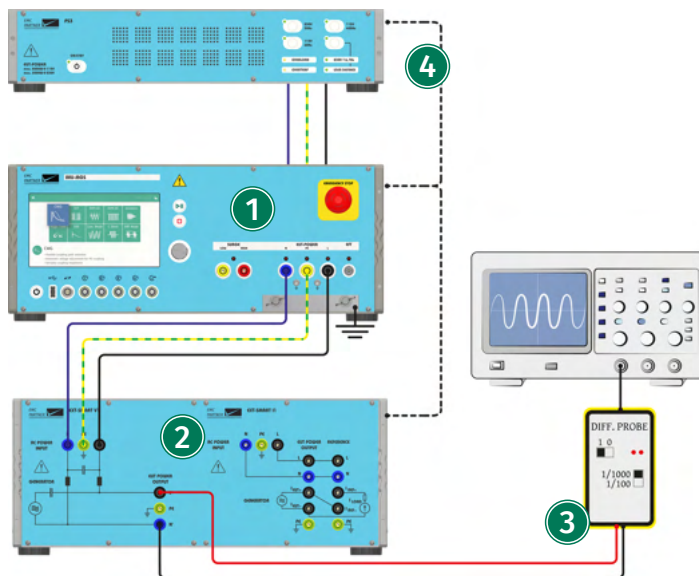

IMU-MGS or IMU-MGE - IMU SLAVE SMART I1V1 - V-PROBE-SI - optional PS3 with RS485-RS232 ADAPTER

- 1 Generator**
On your IMU-MGS or IMU-MGE generator select the "Differential Mode" immunity test and set the "Test Type" to Voltage. Set all the other test parameters, e.g. wave profile, levels and timing, according to your needs.
- 2 IMU SLAVE SMART**
For the voltage test, only the IMU SLAVE SMART V1 (left side) is needed. Connect the EUT POWER outputs (L,N,PE) of the generator to the AC POWER INPUT (L,N,PE) on the front panel of the IMU SLAVE SMART V1.
- 3 Measurement**
Connect a voltage probe with sufficient specifications, e.g. V-PROBE-SI, to the EUT POWER OUTPUT (L' and N') on the front panel of the IMU SLAVE SMART V1.
- 4 PS3 (optional)**
You can supply the generator via a PS3 power supply, connected to the PWR1 inputs on the rear panel and connected via a RS485-RS232 ADAPTER. Alternatively you can also connect IMU SLAVE SMART directly to your mains power or another single-phase power supply.

17.3.3 Verification of voltage test CDN

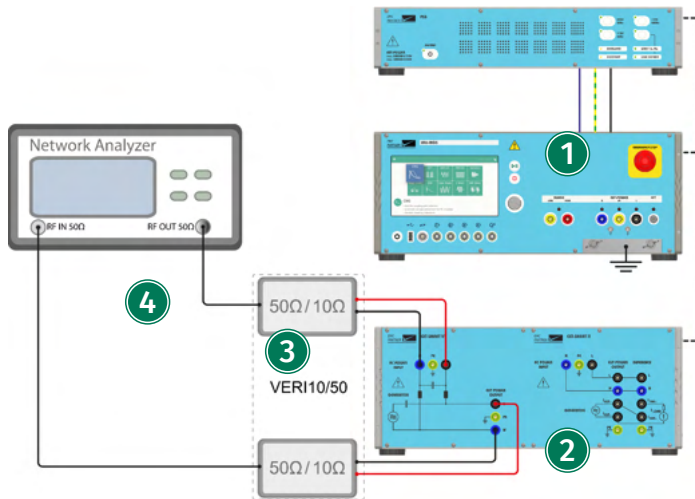

IMU-MGS or IMU-MGE - IMU SLAVE SMART I1V1 - VERI10-50 - optional PS3 with RS485-RS232 ADAPTER

- ① **Generator**
For the verification of the voltage test CDN, the generator is not needed, as it is a passive measurement on the integrated CDN of the IMU SLAVE SMART V1 part.
- ② **IMU SLAVE SMART**
The internal CDN of the IMU SLAVE SMART V1 should be verified, to ensure that it meets the requirements of IEC 61000-4-19.
- ③ **Verification device VERI10/50**
For this verification a VERI10/50 verification device (consisting of two baluns) is required.
- ④ **Measurement**
Connect the first VERI10/50 between the RF output of a vector network analyzer (VNA) and the AC Power input of the SLAVE SMART V1, connect the second VERI10/50 between the RF input of a VNA and the EUT power output of the IMU SLAVE SMART V1. Note that the VNA must provide capabilities in the frequency range of interest of 2 kHz-150 kHz.

18 Tests on Power Lines with External CDNs

This chapter provides additional information on calibration and immunity testing with external CDNs.

18.1 Hardware Description

18.1.1 CDN-M-x-32

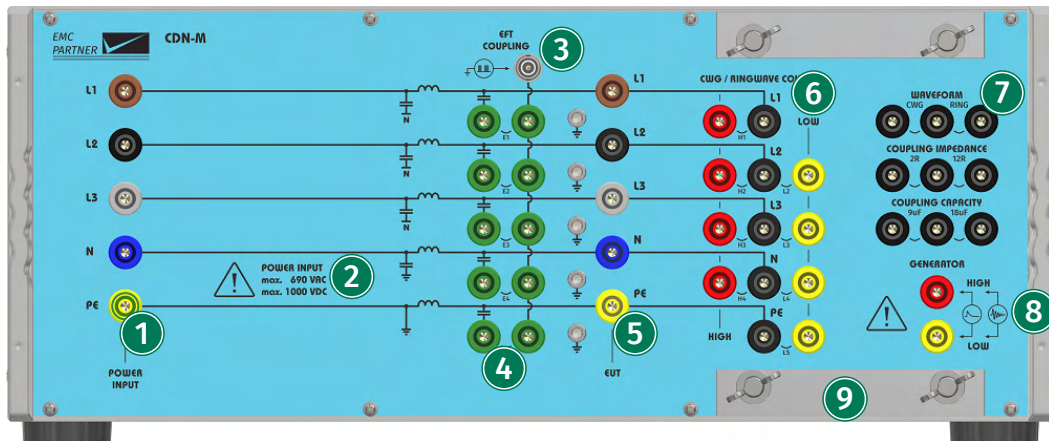

- ① **3-Phase Power Input**
Three-phase (L1, L2, L3, N, PE) power input connectors for equipment up to 32 A.
- ② **Power Input Specifications**
Information regarding the maximal AC and DC voltage specifications of the specific CDN.
- ③ **EFT Generator Input**
High voltage coaxial connector for the EFT direct output of the generator.
- ④ **EFT Coupling Matrix**
The coupling matrix allows the coupling of the EFT burst either on individual lines or on all lines. Use short-circuit bridges to connect that line to the coupling path.
- ⑤ **3-Phase EUT Power Output**
Three-phase (L1, L2, L3, N, PE) power output connectors for equipment up to 32 A.
- ⑥ **CWG and Ring Wave Coupling Matrix**
The coupling matrix allows the coupling of the Surge pulse to individual lines. Connect a line to HIGH by placing a bridge on the left side (red connectors) and connect a line to LOW by placing a bridge on the right side (yellow connectors).
- ⑦ **Waveform and Coupling Impedance Selection Matrix**
This selection matrix allows to select the correct coupling of the waveform and the coupling impedance (in addition to the direct selection on the generator itself).
- ⑧ **CWG and Ring Wave Generator Input**
Input connectors (LOW and HIGH) to connect the Surge direct output of the generator.

9 Protective Earth Connection

The earth terminal allows for a proper connection between test equipment and the reference ground plane to be made. Particularly for interference tests with high frequency components, such as EFT, a large surface earth connection is necessary.

18.1.2

CDN-A-x-32

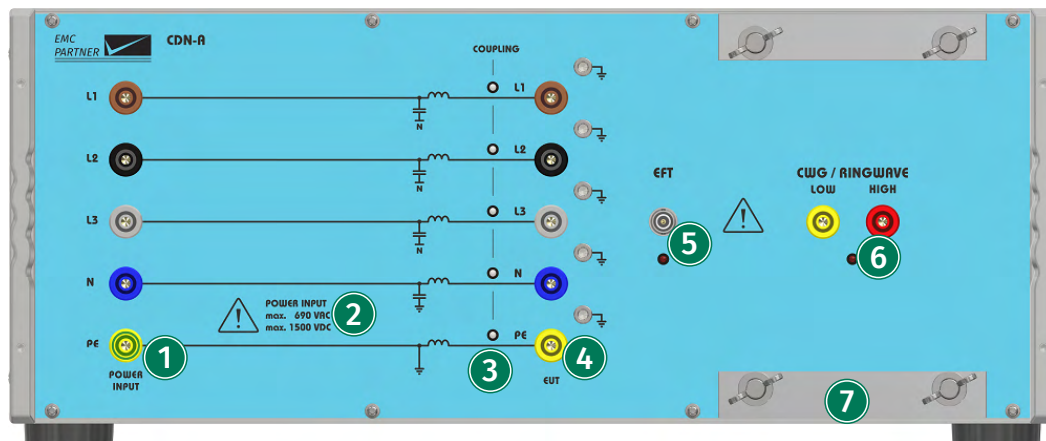

1 3-Phase Power Input

Three-phase (L1, L2, L3, N, PE) power input connectors for equipment up to 32 A.

2 Power Input Specifications

Information regarding the maximal AC and DC voltage specifications of the specific CDN.

3 Coupling LED Indicators

LED indicators show the type of coupling. The LEDs are multicolor, a red LED indicates HIGH and a yellow LED indicates LOW.

4 3-Phase EUT Power Output

Three-phase (L1, L2, L3, N, PE) power output connectors for equipment up to 32 A.

5 EFT Generator Input

High voltage coaxial connector for the EFT direct output of the generator.

6 CWG and Ring Wave Generator Input

Input connectors (LOW and HIGH) to connect the Surge direct output of the generator.

7 Protective Earth Connection

The earth terminal allows for a proper connection between test equipment and the reference ground plane to be made. Particularly for interference tests with high frequency components, such as EFT, a large surface earth connection is necessary.

18.1.3

CDN-A-63



The layout of the upper part of the the CDN-A-x-63 is identical to that of the CDN-A-x-32, except for the input and output power connectors which are laid out for higher currents. Please refer to the CDN-A-x-32 for a more detailed description of the layout.

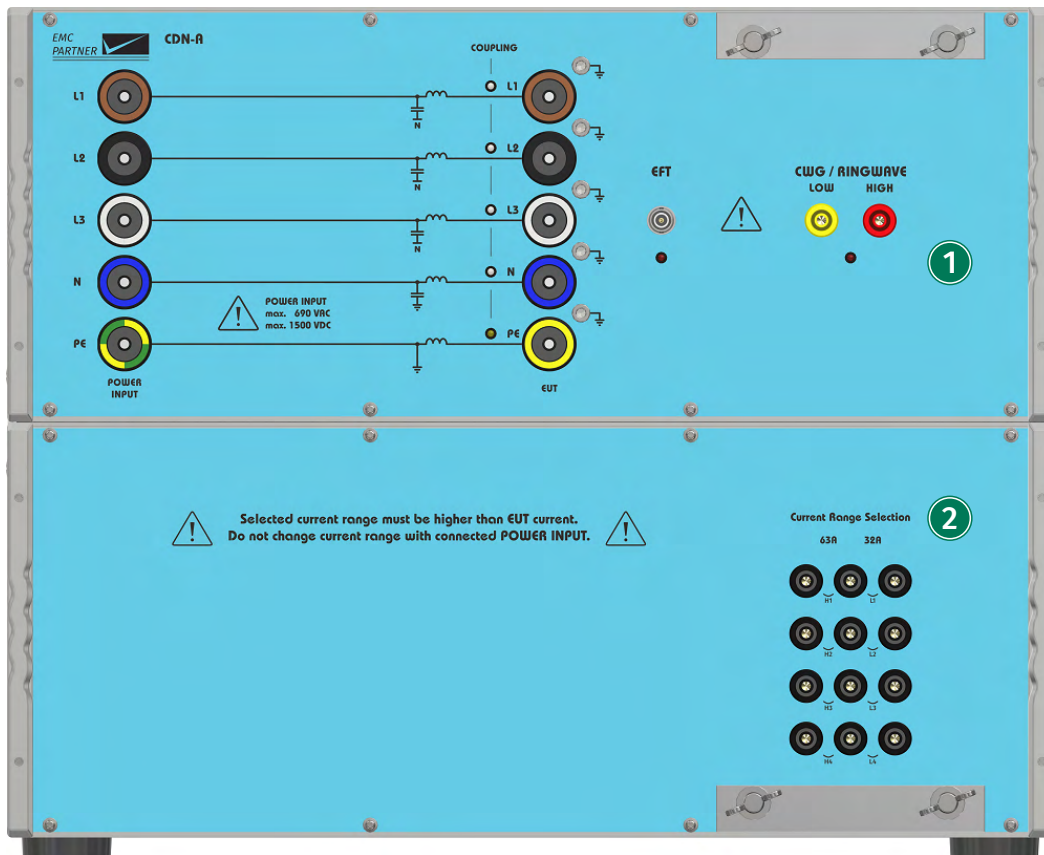

1 Power, EUT, and Generator Input and Output Connections

All connections in the upper part of the CDN-A-63 are identical to those of the CDN-A-32, please refer to this one for further detail. The only difference lies in the current carrying capacity of the input and output connectors.

2 Current Range Selection

In case of a CDN with the "Full Range" option, the current range selection matrix allows you to switch between a 32 A range and the 63 A range by placing the 4 bridges accordingly. All bridges must be plugged in for the same current range.

- Place all 4 bridges in the high positions H1-H4 for the 63 A range.
- Place all 4 bridges in the low positions L1-L4 for the 32 A range.



A lower current range results in a higher line impedance for decoupling. This will have an impact to the duration of the waveform.



Never exceed the current of the selected range. The fuse must be lower or equal than the selected range!

18.1.4

CDN-A-125



The layout of the input and output connections of the CDN-A-x-125 is identical to that of the CDN-A-x-32. Please refer to the CDN-A-x-32 for a more detailed description of the layout.



The AC sockets of CDN-A-x-125 and CDN-A-x-200 are on the front panel. A country specific mains cable is delivered with the equipment, this should be used to connect to the mains power supply. A mains fuse is located in the socket housing. The value is indicated on the equipment type plate.



Take care to ensure the power main matches the power ratings on the equipment type plate. The generator must always be connected to protective earth.

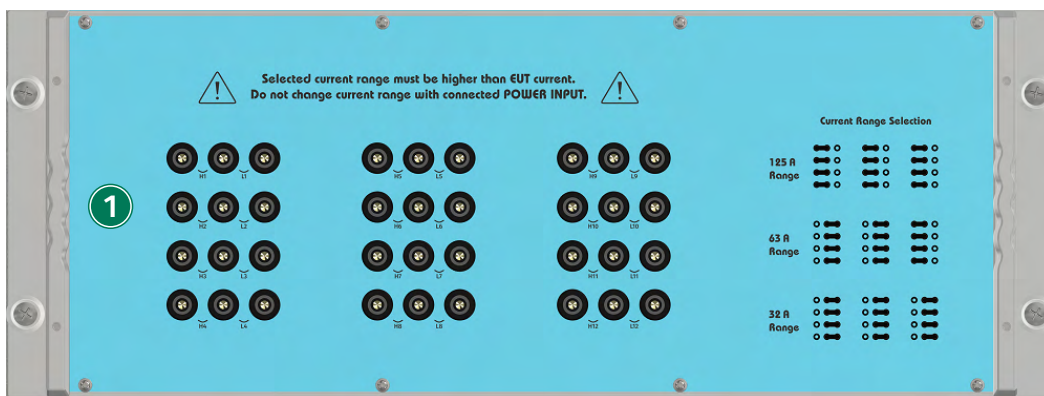

1 Current Range Selection

In case of a CDN with the "Full Range" option, the current range selection matrix allows you to switch between 32 A range, 63 A range, and 125 A range by placing the 12 bridges accordingly (as shown in the diagram on the front panel of the CDN). All bridges must be plugged in for the same current range.

- Place all 12 bridges in the high positions H1-H12 for the 125 A range.
- Place 8 bridges in the low positions L1-L8, and 4 bridges in the high positions L9-L12 for the 63 A range.
- Place all 12 bridges in the low positions L1-L12 for the 32 A range.



A lower current range results in a higher line impedance for decoupling. This will have an impact to the duration of the waveform.



Never exceed the current of the selected range. The fuse must be lower or equal than the selected range!

18.1.5

CDN-A-200



The layout of the input and output connections of the CDN-A-x-200 is identical to that of the CDN-A-x-32, except for the input and output power connectors which are laid out for higher currents. Please refer to the CDN-A-x-32 for a more detailed description of the layout.



The AC sockets of CDN-A-x-125 and CDN-A-x-200 are on the front panel. A country specific mains cable is delivered with the equipment, this should be used to connect to the mains power supply. A mains fuse is located in the socket housing. The value is indicated on the equipment type plate.



Take care to ensure the power main matches the power ratings on the equipment type plate.

The generator must always be connected to protective earth.

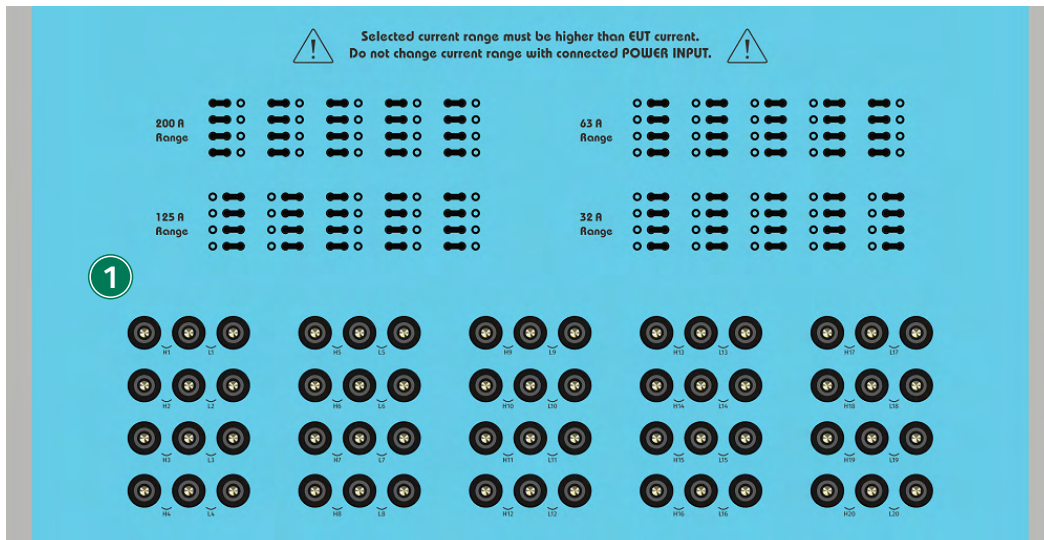

1 Current Range Selection

In case of a CDN with the "Full Range" option, the current range selection matrix allows you to switch between 32 A range, 63 A range, 125 A range, and 200 A range by placing the 20 bridges accordingly (as shown in the diagram on the front panel of the CDN). All bridges must be plugged in for the same current range.

- Place all 20 bridges in the high positions H1-H20 for the 200 A range.
- Place 8 bridges in the low positions L1-L8, and 12 bridges in the high positions H9-H20 for the 125 A range.
- Place 16 bridges in the low positions L1-L16, and 4 bridges in the high positions H17-H20 for the 63 A range.
- Place all 20 bridges in the low positions L1-L20 for the 32 A range.



A lower current range results in a higher line impedance for decoupling. This will have an impact to the duration of the waveform.



Never exceed the current of the selected range. The fuse must be lower or equal than the selected range!

18.1.6

CDN-F-125

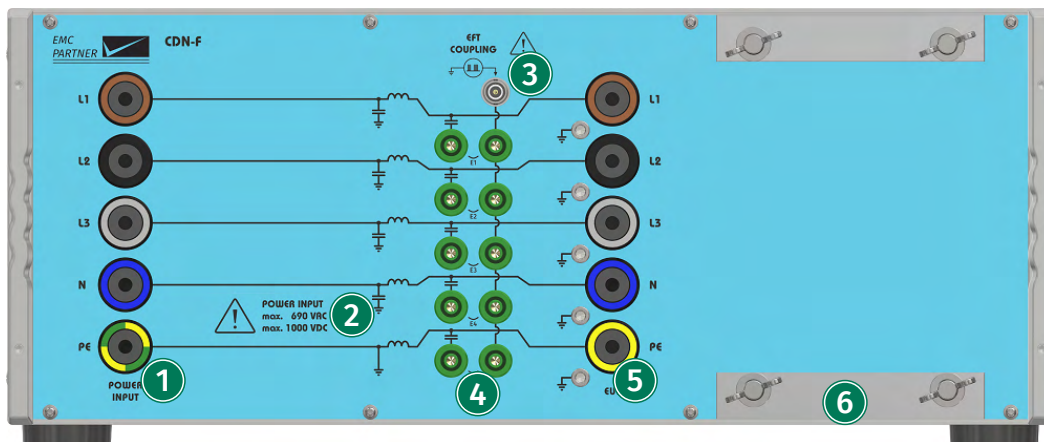

- ① **3-Phase Power Input**
Three-phase (L1, L2, L3, N, PE) power input connectors for equipment up to 125 A.
- ② **Power Input Specifications**
Information regarding the maximal AC and DC voltage specifications of the specific CDN.
- ③ **EFT Generator Input**
High voltage coaxial connector for the EFT direct output of the generator.
- ④ **EFT Coupling Matrix**
The coupling matrix allows the coupling of the EFT burst either on individual lines or on all lines. Use short-circuit bridges to connect that line to the coupling path.
- ⑤ **3-Phase EUT Power Output**
Three-phase (L1, L2, L3, N, PE) power output connectors for equipment up to XA.
- ⑥ **Protective Earth Connection**
The earth terminal allows for a proper connection between test equipment and the reference ground plane to be made. Particularly for interference tests with high frequency components, such as EFT, a large surface earth connection is necessary.

18.2

CDN-A Test Setups



As all automatic CDNs (CDN-A-x-32, CDN-A-x-63, CDN-A-x-125, CDN-A-x-200) have the same connection interface, in the following paragraphs only the connection diagrams for either the CDN-A-x-32 or CDN-A-x-63 are shown. The connections for the other automatic CDNs are identical.

18.2.1 CDN-A AC-Test Setup for Surge and Ring Wave

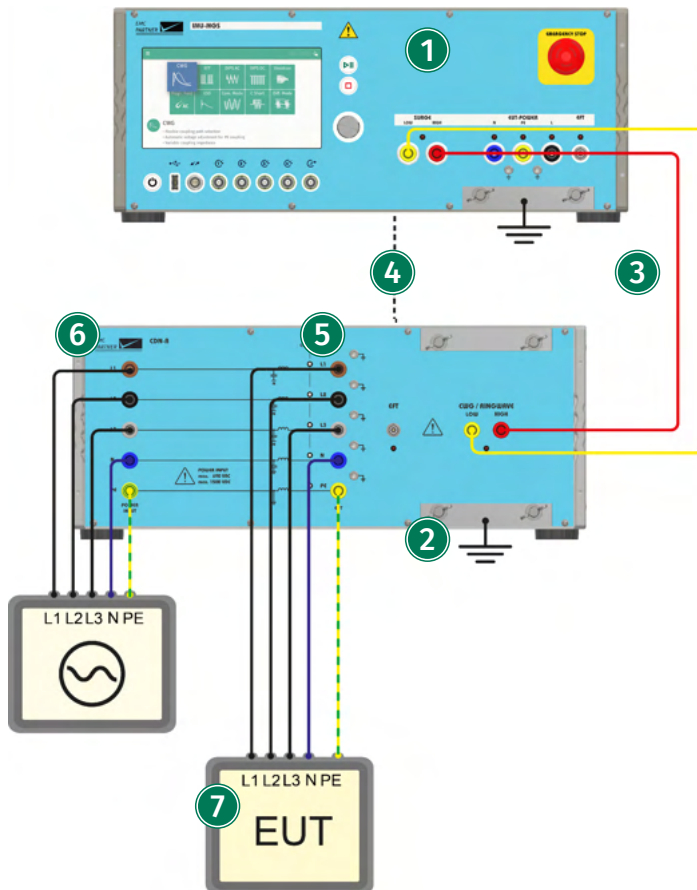

IMU-MGS or IMU-MGE - CDN-A-x-32 or CDN-A-x-63 or CDN-A-x-125 or CDN-A-x-200

1 Generator

On your IMU-MGS or IMU-MGE generator select the "CWG" or "Ring Wave" immunity test and set the test parameters according to your needs. Select the (Coupling) menu tab, and set "Device" to your CDN, e.g. CDN-A-32, and "Coupling" to Impulse Out.

2 CDN

Connect the CDN-A to the public power mains. The CDN-A-x-32 and CDN-A-x-63 have the connector on the back panel, the CDN-A-x-125 and CDN-A-x-200 have the connector on the front panel. Connect the CDN to protective earth.

3 Impulse Connection

Connect the output of the generator to the input of the CDN. Use only the supplied cables. For CWG / Ring Wave, use 1 m low impedance twisted pair cable.

4 Control Connection

On the back, connect the RS485 control from the generator to the CDN. Use only the supplied cable.

5 Coupling Selection

The colour LEDs will light up and indicate the coupling path you have selected on the generator (a red LED indicates HIGH, a yellow LED indicates LOW).

6 Power Input

Line, Neutral and Earth is connected directly to the CDN if no external fuse is used. For a 3-phase system, L1, L2 and L3 is used. For a 1-phase system, only L1 is used.



High earth leakage currents

Due to the filter capacitors in the CDN and the coupling capacitor in the generator, an earth leakage current can flow. Earth leakage breakers in the public supply main should be deactivated or an insulating transformer used.

7 Equipment Under Test (EUT)

Connect the EUT to the output of the CDN (EUT-POWER).

18.2.2

CDN-A AC-Test Setup for EFT

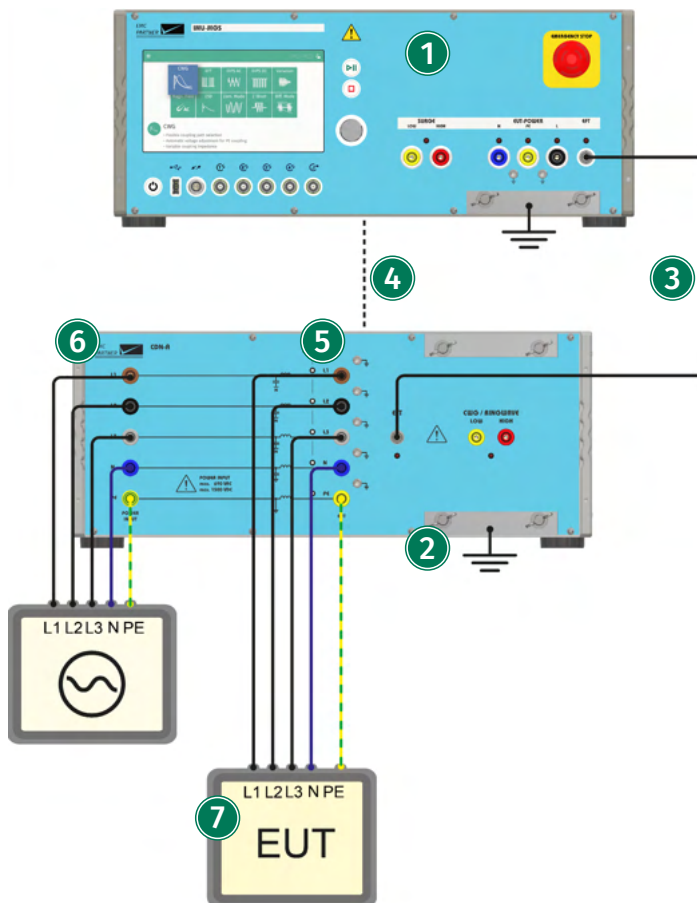

IMU-MGS or IMU-MGE - CDN-A-x-32 or CDN-A-x-63 or CDN-A-x-125 or CDN-A-x-200

1 Generator

On your IMU-MGS or IMU-MGE generator select the "EFT" immunity test and set the test para-

meters according to your needs. Select the (Coupling) menu tab, and set "Device" to your CDN, e.g. CDN-A-32, and "Coupling" to Impulse Out.

- ② **CDN**
Connect the CDN-A to the public power mains. The CDN-A-x-32 and CDN-A-x-63 have the connector on the back panel, the CDN-A-x-125 and CDN-A-x-200 have the connector on the front panel. Connect the CDN to protective earth.
- ③ **Impulse Connection**
Connect the output of the generator to the input of the CDN. Use only the supplied cables. For EFT use a 1 m HV-BNC cable.
- ④ **Control Connection**
On the back, connect the RS485 control from the generator to the CDN. Use only the supplied cable.
- ⑤ **Coupling Selection**
The colour LEDs will light up and indicate the coupling path you have selected on the generator (a red LED indicates HIGH, a yellow LED indicates LOW).
- ⑥ **Power Input**
Line, Neutral and Earth is connected directly to the CDN if no external fuse is used. For a 3-phase system, L1, L2 and L3 is used. For a 1-phase system, only L1 is used.



High earth leakage currents

Due to the filter capacitors in the CDN and the coupling capacitor in the generator, an earth leakage current can flow. Earth leakage breakers in the public supply main should be deactivated or an insulating transformer used.

- ⑦ **Equipment Under Test (EUT)**
Connect the EUT to the output of the CDN (EUT-POWER).

18.2.3

CDN-A AC-Test Setup with PROTxx-AC690

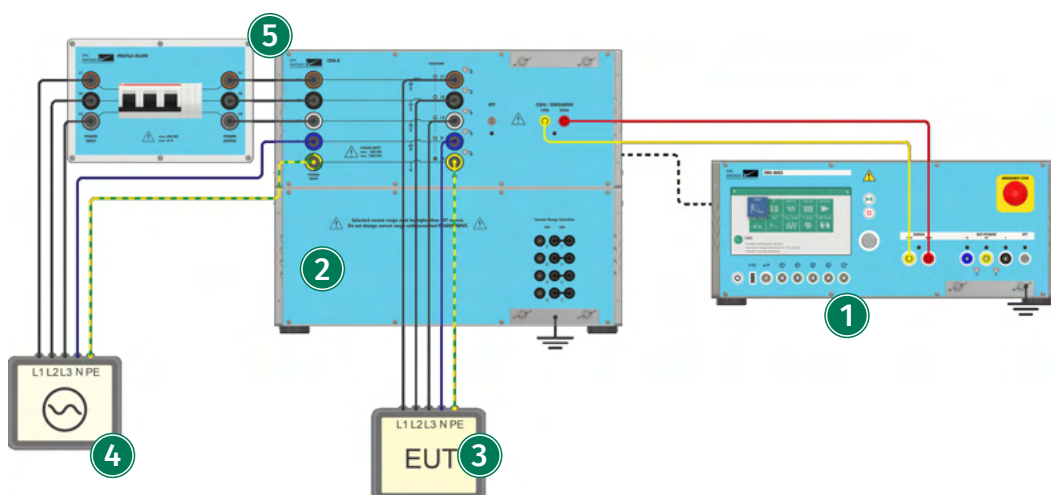

IMU-MGS or IMU-MGE - CDN-A-x-32 or CDN-A-x-63 or CDN-A-x-125 or CDN-A-x-200 - PROTxx-AC690

- ① **Generator**
Connect your IMU-MGS or IMU-MGE generator to your CDN as normally. In this picture connections for a CWG / Ruing Wave test are shown. On the back, connect the RS485 control from the generator to the CDN.
- ② **CDN**
Connect your CDN to the power mains as normally. In this example a CDN-A-63 with Full Range option is depicted.
- ③ **Equipment Under Test (EUT)**
Connect the equipment under test, as normally, to the EUT Power Output Port of your CDN.
- ④ **AC Supply**
The AC power supply (single-phase or three-phase) can be either a stand-alone power supply or the power grid.
- ⑤ **PROTxx-AC690**
The optional fuse PROTxx-AC690 can be connected between the EUT power supply and the power input of the CDN. Neutral and Earth is always connected directly to the CDN.



Make sure not to exceed the maximal voltage and current ratings of the PROTxx-AC690 model you are using. The technical specifications of the various PROT devices are given in ???. If the CDN has a selectable current range, the current rating of the fuse must be equal or lower than the selected current rating.



The housing of PROT200-690AC must be connected to protective earth on the back. This is not required for lower current circuit breaker due to the isolated housing.

18.2.4 CDN-A DC-Test Setup

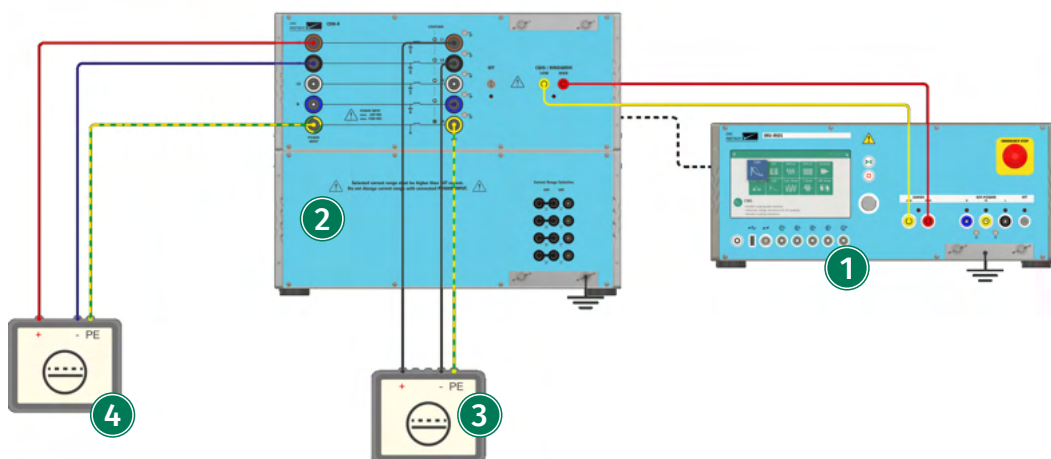

IMU-MGS or IMU-MGE - CDN-A-x-32 or CDN-A-x-63 or CDN-A-x-125 or CDN-A-x-200 -

- ① **Generator**
Connect your IMU-MGS or IMU-MGE generator to your CDN as normally. In this picture connections for a CWG / Ruing Wave test are shown. On the back, connect the RS485 control from the generator to the CDN.

2 CDN

Connect your CDN to the power mains as normally. In this example a CDN-A-63 with Full Range option is depicted.

For DC Power inputs DC+ and DC- are connected directly to the CDN if no external fuse is used. Up to 2 DC Strings can be connected to the CDN.

- String 1: DC+ to L1, DC- to L2
- String 2: DC+ to L3, DC- to N



The 2 strings can be connected in parallel. This will double the current range of the CDN. Monitor the current in each string permanently to ensure, that the maximum current rating of a single string is never exceeded.

3 Equipment Under Test (EUT)

Connect the equipment under test, as normally, to the EUT Power Output Port of your CDN. In this case a DC powered EUT is depicted connected to DC String 1 (DC+ to L1, DC- to L2).



When the EUT power is higher than 1000Vdc, the following safety advices must be followed:

- An additional safety barrier must be around the EUT and CDN.
- Do not touch any cables.

4 DC Supply

DC Power Source with DC+, DC- and PE outputs.

18.2.5

CDN-A DC-Test Setup with PROTx-DCyy

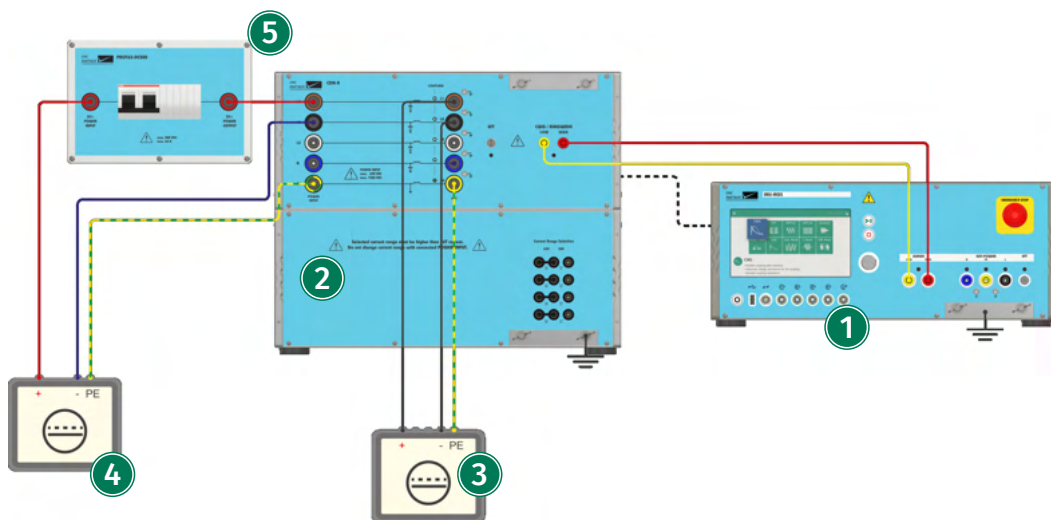

IMU-MGS or IMU-MGE - CDN-A-x-32 or CDN-A-x-63 or CDN-A-x-125 or CDN-A-x-200 - PROTx-DCyy

1 Generator

Connect your IMU-MGS or IMU-MGE generator to your CDN as normally. In this picture connections for a CWG / Ruing Wave test are shown. On the back, connect the RS485 control from the generator to the CDN.

- ② **CDN**
In this example a CDN-A-63 with Full Range option is depicted.
- ③ **Equipment Under Test (EUT)**
Connect the equipment under test, as normally, to the EUT Power Output Port of your CDN. In this case a DC powered EUT is depicted connected to DC String 1 (DC+ to L1, DC- to L2).
- ④ **DC Supply**
DC Power Source with DC+, DC- and PE outputs.
- ⑤ **PROTxx-DCyy**
The optional fuse PROTxx-DCyy can be connected between the EUT power supply and the power input of the CDN. DC- is always connected directly to the CDN.



Make sure not to exceed the maximal voltage and current ratings of the PROTxx-DCyy model you are using. The technical specifications of the various PROT devices are given in ???. If the CDN has a selectable current range, the current rating of the fuse must be equal or lower than the selected current rating.

18.2.6 CDN-A DC-Test Setup with DC-DCxx Damping Network

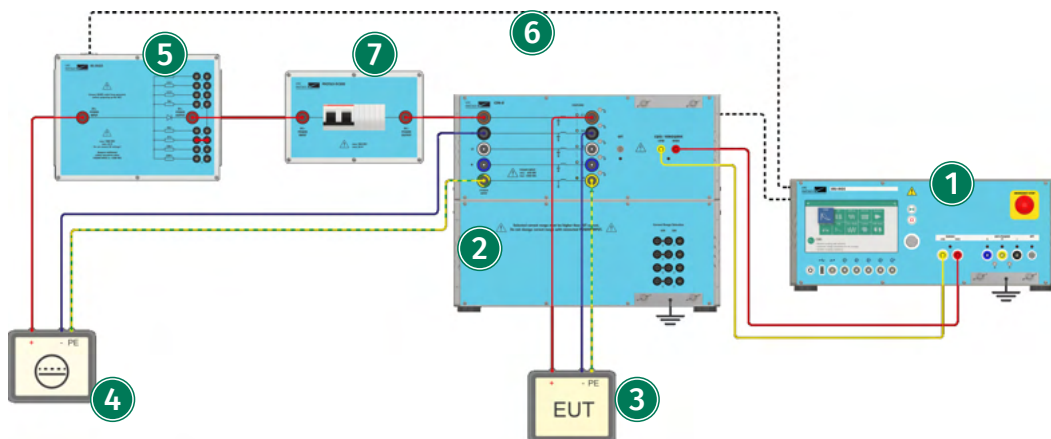

IMU-MGS or IMU-MGE - CDN-A-x-32 or CDN-A-x-63 or CDN-A-x-125 or CDN-A-x-200 - PROTxx-DCyy - DC-DCxx -

- ① **Generator**
Connect your IMU-MGS or IMU-MGE generator to your CDN as normally. In this picture connections for a CWG / Ruing Wave test are shown. On the back, connect the RS485 control from the generator to the CDN.
- ② **CDN**
In this example a CDN-A-63 with Full Range option is depicted.
- ③ **Equipment Under Test (EUT)**
Connect the equipment under test, as normally, to the EUT Power Output Port of your CDN. In this case a DC powered EUT is depicted connected to DC String 1 (DC+ to L1, DC- to L2).
- ④ **DC Supply**
DC Power Source with DC+, DC- and PE outputs.

5 DC-DCxx

The DC-DCxx consists of a high-performance diode and a damping resistor. It is designed to suppress possible oscillations on the DC supply line. The optimal value of the damping resistor depends on the individual test setup, including the DC power source, the CDN, and the EUT. Therefore, the DC-DCxx allows you the selection among the following fixed values 1 Ohm, 2.2 Ohm, 4.7 Ohm, 10 Ohm, 22 Ohm, 47 Ohm, 100 Ohm, or 220 Ohm, as well as possible values through parallel connection of the given resistors.



Make sure not to exceed the maximal voltage and current ratings of the DC-DCxx model you are using. The technical specifications of the various PROT devices are given in ??.



Make sure to connect the DC-DCxx correctly into your DC+ or DC- supply line, taking care of the correct polarity.



The depicted test setup shows the CD-DC63. The connections for test setups with different damping circuits (DC-DC32, DCDC63, DC-DC125, DC-DC200) are similar.

6 Control Connection

Connect the RS485 control from the generator rear panel to the DC-DC32. Use only the supplied cable.



The RS485 connector is used to power the internal ventilation via a 24 V connection. Without this connection the fans do not operate and the device could overheat and be damaged as a consequence.

7 PROTx-DCyy

The optional fuse PROTx-DCyy can be connected between the EUT power supply and the power input of the CDN.

18.3 CDN-M Test Setups

18.3.1 CDN-M AC-Test Setup for Surge and Ringwave

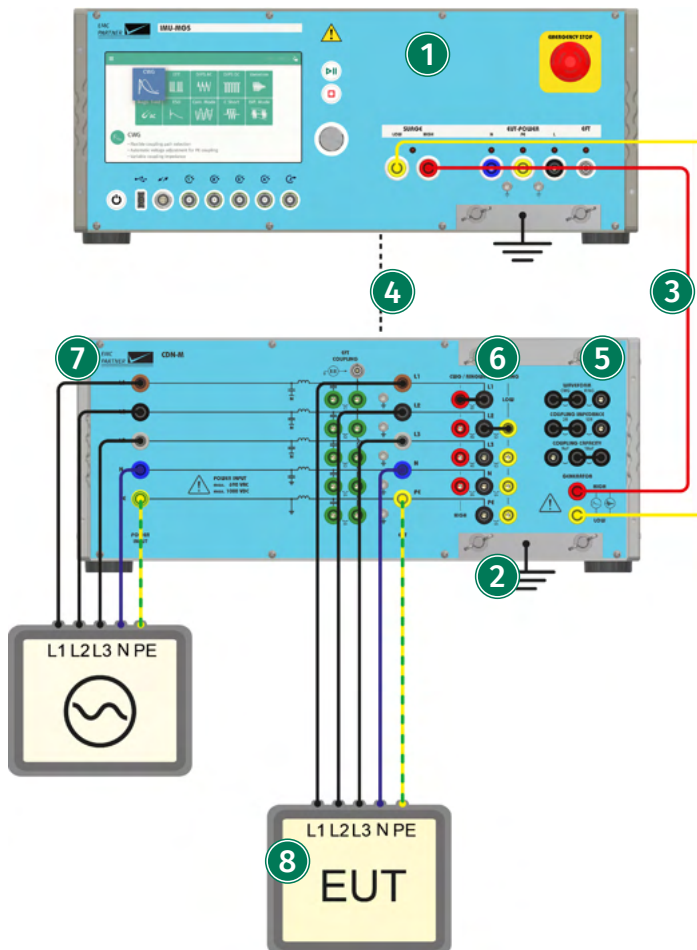

IMU-MGS or IMU-MGE - CDN-M-x-32

1 Generator

On your IMU-MGS or IMU-MGE generator select the "CWG" or "Ring Wave" immunity test and set the test parameters according to your needs. Select the (Coupling) menu tab, and set "Device" to CDN-M-32 and "Coupling" to Impulse Out.

2 CDN

Connect the CDN-M to the protective earth.

3 Impulse Connection

Connect the output of the generator to the input of the CDN. Use only the supplied cables. For CWG / Ring Wave, use 1 m low impedance twisted pair cable.

4 Control Connection

On the back, connect the RS485 control from the generator to the CDN. Use only the supplied cable.

5 Waveform Selection

The first bridge is for the selection between CWG and Ringwave impulse. For CWG, the desired coupling impedance (2 or 12 Ohm) and coupling capacity (9 or 18 uF) can be selected in any combination. During Ring Wave test, the selected coupling impedance and coupling capacity has no effect.



IEC61000-4-5 request 2 Ohm / 18 uF for Line-Line coupling and 12 Ohm / 9 uF for Line-PE coupling.

6 Surge Coupling

Plug in one single bridge for the desired high coupling (H1 - H4). With a second bridge, the low path for the coupling is selected (L2 - L5).



Danger of short circuit

Never plug in 2 bridges at the same time on the high side (H1 - H4) or low side (L2-L5).



During a CWG or Ring wave pulse, the EFT bridges must be removed!

7 Power Input

Line, Neutral and Earth is connected directly to the CDN if no external fuse is used. For a 3-phase system, L1, L2 and L3 is used. For a 1-phase system, only L1 is used.



High earth leakage currents

Due to the filter capacitors in the CDN and the coupling capacitor in the generator, an earth leakage current can flow. Earth leakage breakers in the public supply main should be deactivated or an insulating transformer used.

8 Equipment Under Test (EUT)

Connect the EUT to the output of the CDN (EUT-POWER).

18.3.2 CDN-M AC-Test Setup for EFT

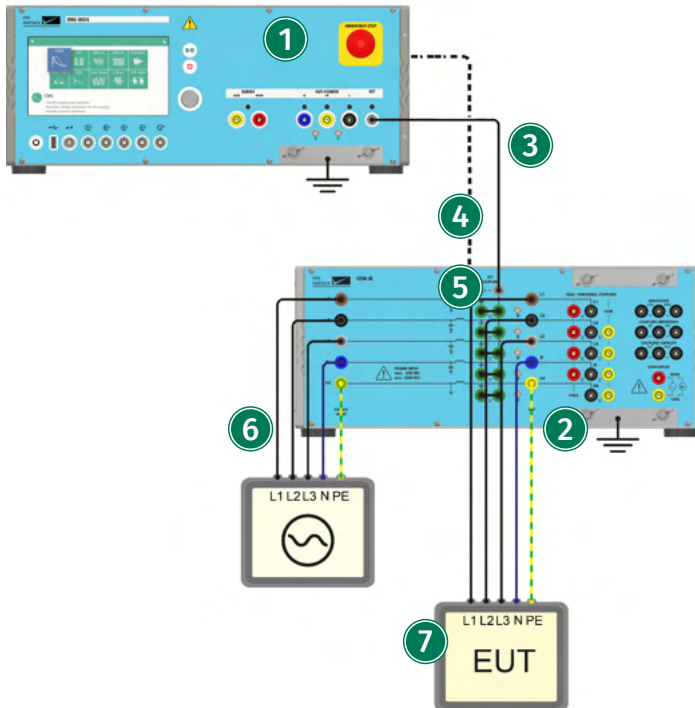

IMU-MGS or IMU-MGE - CDN-M-x-32

- 1 Generator**
On your IMU-MGS or IMU-MGE generator select the "EFT" immunity test and set the test parameters according to your needs. Select the (Coupling) menu tab, and set "Device" to CDN-M-32 and "Coupling" to Impulse Out.
 - 2 CDN**
Connect the CDN-M to the protective earth.
 - 3 Impulse Connection**
Connect the output of the generator to the input of the CDN. Use only the supplied cables. For EFT use a 1 m HV-BNC cable.
 - 4 Control Connection**
On the back, connect the RS485 control from the generator to the CDN. Use only the supplied cable.
 - 5 EFT Coupling**
Plug in the bridge E1 to E5 for the desired EFT coupling. For the default common mode coupling according IEC-61000-4-4, all 5 bridges must be plugged in.
-  During a CWG or Ringwave pulse, the EFT bridges must be removed!
- 6 Power Input**
Line, Neutral and Earth is connected directly to the CDN if no external fuse is used. For a 3-phase system, L1, L2 and L3 is used. For a 1-phase system, only L1 is used.



High earth leakage currents

Due to the filter capacitors in the CDN and the coupling capacitor in the generator, an earth leakage current can flow. Earth leakage breakers in the public supply main should be deactivated or an insulating transformer used.

7 Equipment Under Test (EUT)

Connect the EUT to the output of the CDN (EUT-POWER).

18.3.3 CDN-M DC-Test Setups



The DC-test setup for the manual CDN-M-x-32 is identical to that for the automatic CDNs. Please refer to the section "CDN-A DC-Test Setup" for further information.

18.3.4 CDN-M Test Setups with PROT and DC-DC-xx accessories



The DC-test setup for the manual CDN-M-x-32 is identical to that for the automatic CDNs. Please refer to the sections "CDN-A DC-Test Setup with PROTxx-DCyy" and "CDN-A DC-Test Setup with DC-DCxx Damping Network" for further information.

18.4 CDN-F Test Setups

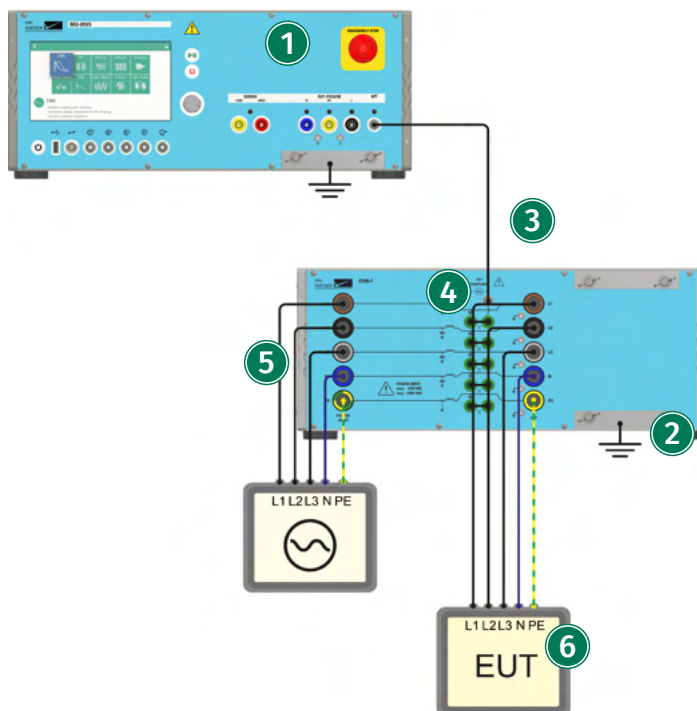

IMU-MGS or IMU-MGE - CDN-F-xx

1 Generator

On your IMU-MGS or IMU-MGE generator select the "EFT" immunity test and set the test parameters according to your needs. Select the (Coupling) menu tab, and set "Device" to CDN-F-x and "Coupling" to Impulse Out.

- ② **CDN**
Connect the CDN-M to the protective earth.
- ③ **Impulse Connection**
Connect the output of the generator to the input of the CDN. Use only the supplied cables. For EFT use a 1 m HV-BNC cable.
- ④ **EFT Coupling**
Plug in the bridge E1 to E5 for the desired EFT coupling. For the default common mode coupling according IEC-61000-4-4, all 5 bridges must be plugged in.



During a CWG or Ringwave pulse, the EFT bridges must be removed!

- ⑤ **Power Input**
Line, Neutral and Earth is connected directly to the CDN if no external fuse is used. For a 3-phase system, L1, L2 and L3 is used. For a 1-phase system, only L1 is used.



High earth leakage currents

Due to the filter capacitors in the CDN and the coupling capacitor in the generator, an earth leakage current can flow. Earth leakage breakers in the public supply main should be deactivated or an insulating transformer used.

- ⑥ **Equipment Under Test (EUT)**
Connect the EUT to the output of the CDN (EUT-POWER).

18.5 Calibration

18.5.1 Surge and Ring Wave Calibration



Additional information for calibration is also available in the calibration report.

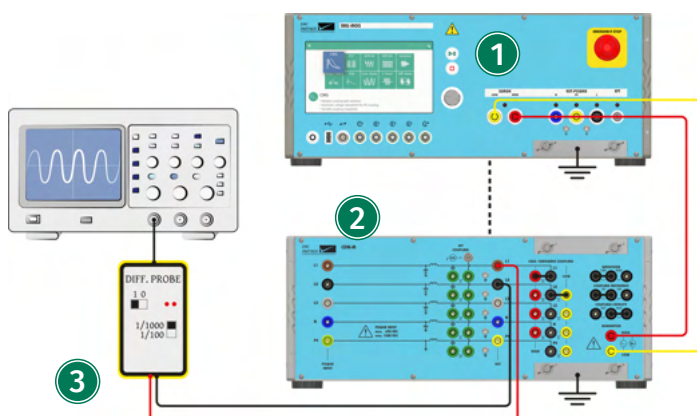

IMU-MGS or IMU-MGE - CDN-M-x-32 - V-PROBE-SI

- ① **Generator**
On your IMU-MGS or IMU-MGE generator select the "CWG" or "Ringwave" immunity test and set the test parameters according to your needs. Select the (Coupling) menu tab, and set "Device" to CDN-M-32 and "Coupling" to Impulse Out.

2 CDN

Connect the generator Surge direct output (LOW and HIGH) to the CDN Surge generator input (LOW and HIGH) using a 1 m low impedance twisted pair cable.

On the back, connect the RS485 control from the generator to the CDN. Use only the supplied cable.

Set the coupling according to your needs using the "Surge and Ring Wave Coupling Matrix" and the "Waveform and Coupling Impedance Selection Matrix". The first bridge is for the selection between CWG and Ringwave impulse. For CWG, the desired coupling impedance (2 or 12 Ohm) and coupling capacity (9 or 18 uF) can be selected in any combination. During Ring Wave test, the selected coupling impedance and coupling capacity has no effect.



IEC61000-4-5 request 2 Ohm / 18 uF for Line-Line coupling and 12 Ohm / 9 uF for Line-PE coupling.

Plug in one single bridge for the desired high coupling (H1 - H4). With a second bridge, the low path for the coupling is selected (L2 - L5).



Danger of short circuit

Never plug in 2 bridges at the same time on the high side (H1 - H4) or low side (L2-L5).



During a CWG or Ring wave pulse, the EFT bridges must be removed!

3 Measurement

Connect a differential probe with sufficient specifications, e.g. V-PROBE-SI, to the lines you want to calibrate at the output port of your CDN.

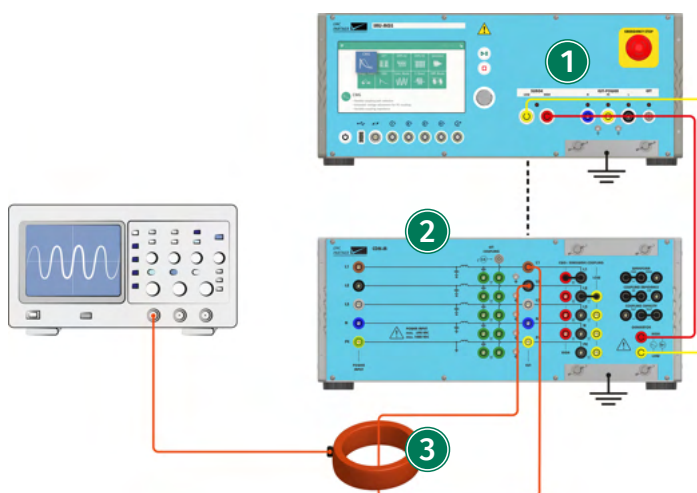

IMU-MGS or IMU-MGE - CDN-M-x-32 - I-PROBE-P101

1 Generator

On your IMU-MGS or IMU-MGE generator select the "CWG" immunity test and set the test parameters according to your needs. Select the (Coupling) menu tab, and set "Device" to CDN-M-32 and "Coupling" to Impulse Out. On the back, connect the RS485 control from the generator to the CDN. Use only the supplied cable.

2 CDN

Connect the generator Surge direct output (LOW and HIGH) to the CDN Surge generator input (LOW and HIGH) using a 1 m low impedance twisted pair cable.

On the back, connect the RS485 control from the generator to the CDN. Use only the supplied cable.

Set the coupling according to your needs using the "Surge and Ring Wave Coupling Matrix" and the "Waveform and Coupling Impedance Selection Matrix". The first bridge is for the selection between CWG and Ringwave impulse. For CWG, the desired coupling impedance (2 or 12 Ohm) and coupling capacity (9 or 18 uF) can be selected in any combination. During Ring Wave test, the selected coupling impedance and coupling capacity has no effect.



IEC61000-4-5 request 2 Ohm / 18 uF for Line-Line coupling and 12 Ohm / 9 uF for Line-PE coupling.

Plug in one single bridge for the desired high coupling (H1 - H4). With a second bridge, the low path for the coupling is selected (L2 - L5).



Danger of short circuit

Never plug in 2 bridges at the same time on the high side (H1 - H4) or low side (L2-L5).



During a CWG or Ring wave pulse, the EFT bridges must be removed!

3 Measurement

Connect a current probe with sufficient specifications, e.g. I-PROBE-P101, to the lines to be calibrated at the output port of your CDN



As all automatic CDNs (CDN-A-32, CDN-A-63, CDN-A-125, CDN-A-200) have the same connection interface, in the following paragraphs only the connection diagrams for the CDN-A-32 are shown. The connections for the other mentioned automatic CDNs are identical.

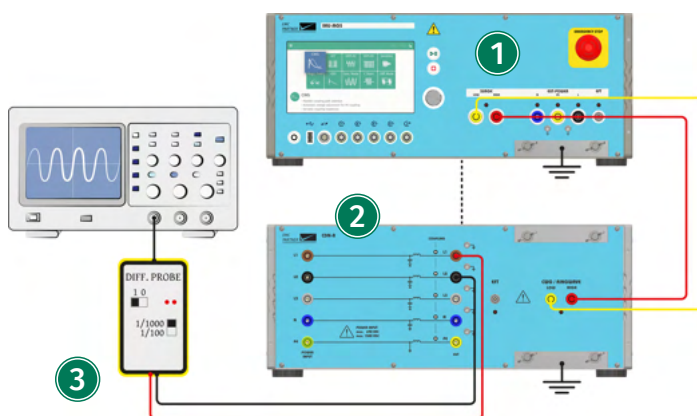

IMU-MGS or IMU-MGE - CDN-A-x-32 or CDN-A-x-63 or CDN-A-x-125 or CDN-A-x-200 - V-PROBE-SI

1 Generator

On your IMU-MGS or IMU-MGE generator select the "CWG" immunity test and set the test parameters according to your needs. Select the (Coupling) menu tab, and set "Device" to CDN-A-x and "Coupling" to Impulse Out.

2 CDN

Connect the CDN-A to the public power mains. The CDN-A-x-32 and CDN-A-x-63 have the connector on the back panel, the CDN-A-x-125 and CDN-A-x-200 have the connector on the front panel. Connect the CDN to protective earth.

Connect the generator Surge direct output (LOW and HIGH) to the CDN Surge generator input (LOW and HIGH) using a 1 m low impedance twisted pair cable.

On the back, connect the RS485 control from the generator to the CDN. Use only the supplied cable.

The color LEDs will light up and indicate the coupling path you have selected on the generator (a red LED indicates HIGH, a yellow LED indicates LOW).

3 Measurement

Connect a differential probe with sufficient specifications, e.g. V-PROBE-SI, to the lines you want to calibrate at the output port of your CDN.

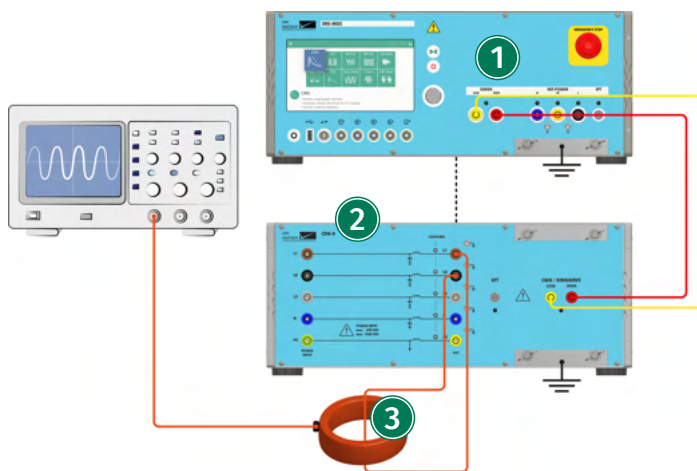

IMU-MGS or IMU-MGE - CDN-A-x-32 or CDN-A-x-63 or CDN-A-x-125 or CDN-A-x-200 - I-PROBE-P101

1 Generator

On your IMU-MGS or IMU-MGE generator select the "CWG" immunity test and set the test parameters according to your needs. Select the (Coupling) menu tab, and set "Device" to CDN-A-x and "Coupling" to Impulse Out. On the back, connect the RS485 control from the generator to the CDN. Use only the supplied cable.

2 CDN

Connect the CDN-A to the public power mains. The CDN-A-x-32 and CDN-A-x-63 have the connector on the back panel, the CDN-A-x-125 and CDN-A-x-200 have the connector on the front panel. Connect the CDN to protective earth.

Connect the generator Surge direct output (LOW and HIGH) to the CDN Surge generator input (LOW and HIGH) using a 1 m low impedance twisted pair cable.

On the back, connect the RS485 control from the generator to the CDN. Use only the supplied cable.

The color LEDs will light up and indicate the coupling path you have selected on the generator (a red LED indicates HIGH, a yellow LED indicates LOW).

3 Measurement

Connect the VERI50-EFT (SHV connector side) to the CDN, using the ADAPTER SHV-MC 32, and connect its output (BNC connector side) to the oscilloscope.

18.5.2

EFT/Burst Calibration

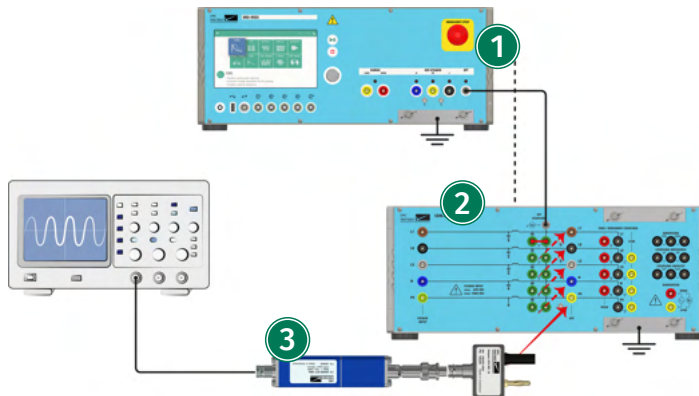

IMU-MGS or IMU-MGE - CDN-M-x-32 - VERI50 EFT

1 Generator

On your IMU-MGS or IMU-MGE generator select the "EFT" immunity test and set the test parameters according to your needs. Select the (Coupling) menu tab, and set "Device" to CDN-M-32 and "Coupling" to Impulse Out.

2 CDN

Connect the generator EFT direct output to the CDN EFT generator input using a 1m HV-BNC cable.

On the back, connect the RS485 control from the generator to the CDN. Use only the supplied cable.

Use the EFT coupling matrix to select the kind of coupling you want to calibrate/verify (single line or all lines). For the default common mode coupling according IEC-61000-4-4, all 5 bridges E1 - E5 must be plugged in.



During a CWG or Ringwave pulse, the EFT bridges must be removed!

3 Measurement

Connect the VERI50-EFT (SHV connector side) to the CDN, using the ADAPTER SHV-MC 32, and connect its output (BNC connector side) to the oscilloscope.



The same calibration setup is also used for the CDN-EFT-x. Depending on the current range, instead of an ADAPTER SHV-MC 32, an ADAPTER SHV-MC 125 or ADAPTER SHV-MC 200 needs to be used.

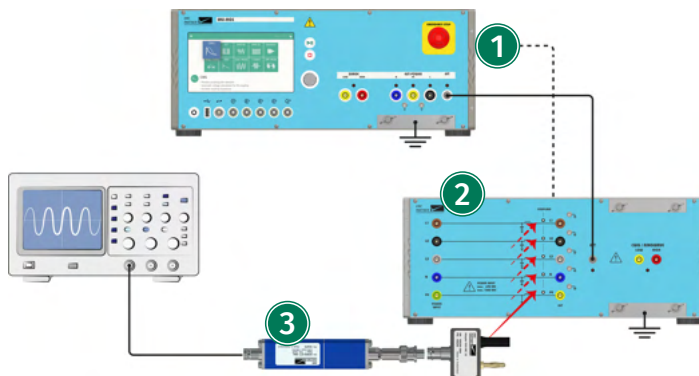

IMU-MGS or IMU-MGE - CDN-A-x-32 or CDN-A-x-63 or CDN-A-x-125 or CDN-A-x-200 - VERI50 EFT

1 Generator

On your IMU-MGS or IMU-MGE generator select the "EFT" immunity test and set the test parameters according to your needs. Select the (Coupling) menu tab, and set "Device" to CDN-A-x and "Coupling" to Impulse Out.

2 CDN

Connect the CDN-A to the public power mains. The CDN-A-x-32 and CDN-A-x-63 have the connector on the back panel, the CDN-A-x-125 and CDN-A-x-200 have the connector on the front panel. Connect the CDN to protective earth.

Connect the generator EFT direct output to the CDN EFT generator input using a 1 m HV-BNC cable.

On the back, connect the RS485 control from the generator to the CDN. Use only the supplied cable.

The colour LEDs will light up and indicate the coupling path you have selected on the generator (a red LED indicates HIGH, a yellow LED indicates LOW).

3 Measurement





Connect the VERI50-EFT (SHV connector side) to the CDN, using the ADAPTER SHV-MC 32, and connect its output (BNC connector side) to the oscilloscope.



For the CDN-A-63 and CDN-A-125 an ADAPTER SHV-MC 125 must be used. For the CDN-A-200 an ADAPTER SHV-MC 200 must be used.

19 Tests on Data Lines with External CDNs

The following table provides a brief overview of different types of data lines and the corresponding EMC PARTNER Data Line CDNs to perform immunity tests on those lines.

Type of lines	Line	CDN-KIT1000 ED3	CDN-DATA-4L	CDN-DATA-8L	CDN-UTP ED3	CDN-UTP8 ED3
Unsymmetrical, unshielded		Yes, max 2 lines	Yes, max 4 lines	Yes, max 8 lines	Yes, max 2 lines	Yes, max 4 lines
Symmetrical, unshielded		-	-	-	Yes, max 4 lines	Yes, max 8 lines
Unsymmetrical, shielded		No CDN required, surge and ring wave are applied on the shield directly from generator				
Symmetrical, shielded						

19.1 CDN-KIT1000 ED3

19.1.1 Test Setup

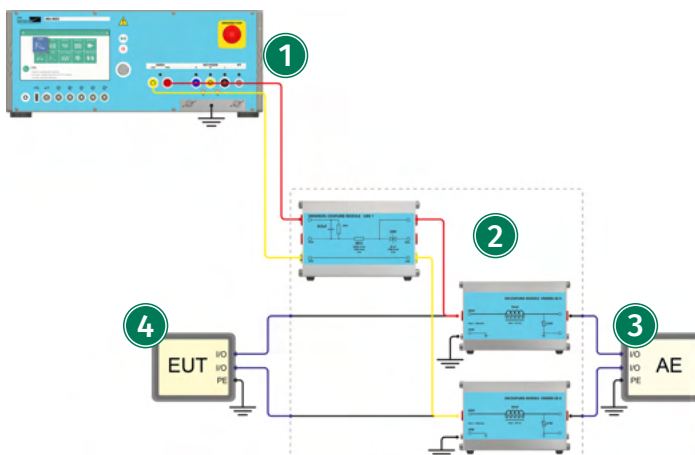

IMU-MGS or IMU-MGE - CDN-KIT1000 ED3

1 Generator

On your IMU-MGS generator select the "Surge" immunity test, on your IMU-MGE generator you can select the "Surge" or "Ring Wave" immunity test and set the test parameters according to your needs. Select the (Coupling) menu tab, and set "Device" to CDN-KIT1000 and "Coupling" to Impulse Out.

2 CDN

Connect the universal coupling module between the Surge direct output of your generator (LOW and HIGH) and the two decoupling modules (chokes). Connect the decoupling modules (chokes) in the pair of data lines you want to test.

- ③ **Auxiliary Equipment (AE)**
Equipment that is necessary for setting up all functions and assessing the correct performance of the EUT during the test.
- ④ **Equipment Under Test (EUT)**
Equipment subjected to the disturbance signal, should be connected to the output port of the coupling network.

19.1.2 Calibration Setup

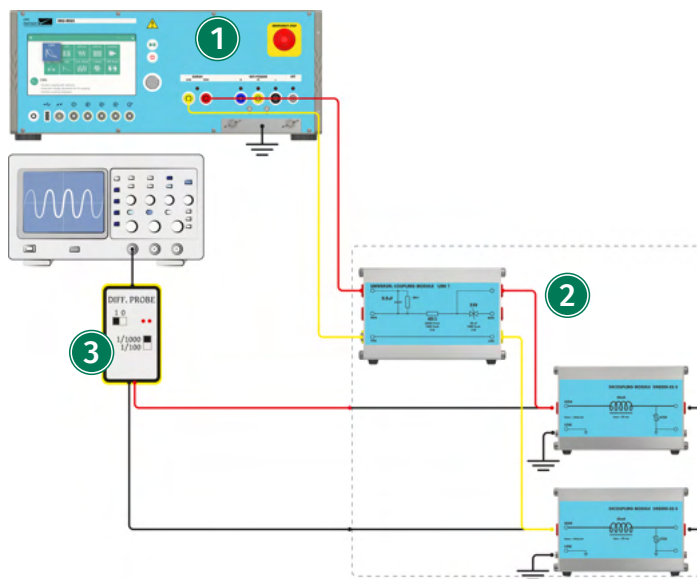

IMU-MGS or IMU-MGE - CDN-KIT1000 ED3 - V-PROBE-SI

- ① **Generator**
On your IMU-MGS generator select the "Surge" immunity test, on your IMU-MGE generator you can select the "Surge" or "Ring Wave" immunity test and set the test parameters according to your needs. Select the (Coupling) menu tab, and set "Device" to CDN-KIT1000 and "Coupling" to Impulse Out.
- ② **CDN**
Connect the universal coupling module between the Surge direct output of your generator (LOW and HIGH) and the two decoupling modules (chokes).
- ③ **Measurement**
Connect a differential probe with sufficient specifications, e.g. V-PROBE-SI, at the output port of your CDN chokes.

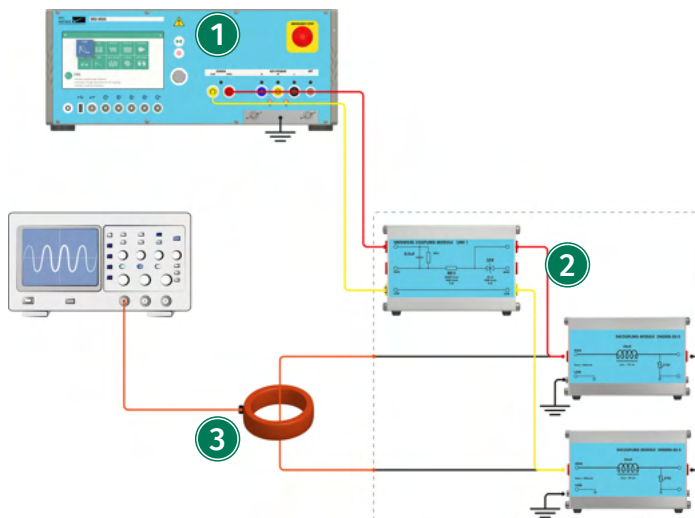

IMU-MGS or IMU-MGE - CDN-KIT1000 ED3 - I-PROBE-P101

1 Generator

On your IMU-MGS generator select the "Surge" immunity test, on your IMU-MGE generator you can select the "Surge" or "Ring Wave" immunity test and set the test parameters according to your needs. Select the (Coupling) menu tab, and set "Device" to CDN-KIT1000 and "Coupling" to Impulse Out.

2 CDN

Connect the universal coupling module between the Surge direct output of your generator (LOW and HIGH) and the two decoupling modules (chokes).

3 Measurement

Connect a current probe with sufficient specifications, e.g. I-PROBE-P101, between the output port of your CDN chokes.

19.2 CDN-DATA-4L/8L

The CDN-DATA-4L and CDN-DATA-8L are manual CDNs that can be used together with EMC PARTNER IMU-MGS and IMU-MGE generators for Surge and Ring Wave tests in order to superpose pulses on signal and data lines, in accordance with latest editions of IEC 61000-4-5 and IEC 61000-4-12. The CDN addresses either 4 or 8 lines, asymmetrical, differential mode coupling (L-L) and common mode coupling (L-PE).

19.2.1 Test Setup

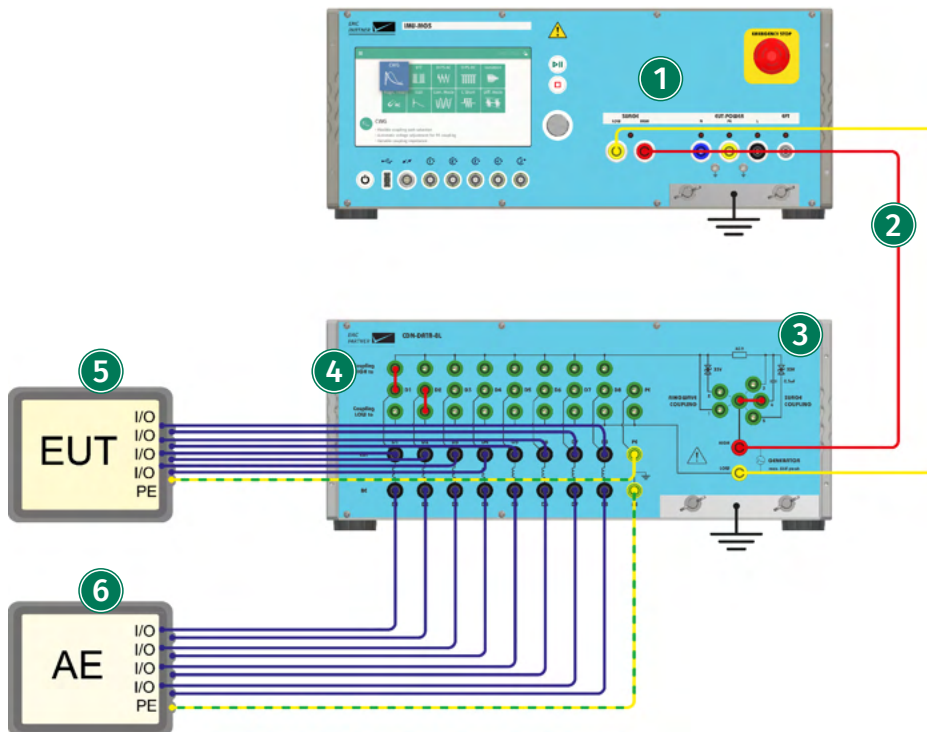

IMU-MGS or IMU-MGE - CDN-DATA-4L or CDN-DATA-8L

1 Generator

On your IMU-MGS generator select the "Surge" immunity test, on your IMU-MGE generator you can select the "Surge" or "Ring Wave" immunity test and set the test parameters according to your needs. Select the (Coupling) menu tab, and set "Device" to CDN-DATA-4L or CDN-DATA-8L. The "Coupling" will be set automatically to Impulse Out.



Even if the generator have a higher capability, the pulse voltage must not exceed 6 kV! Consider the user manual of the generator for more information about setting up a test.

2 Connection to CDN-DATA-4L/8L

Connect the Surge direct output (LOW and HIGH) of the generator to the generator input (LOW and HIGH) at the CDN using a 1m twisted pair cable.

3 Coupling Device

Select the desired coupling device with a bridge between the middle and one of the outer connector. All the Surge coupling path have an 400hm resistor included.

1. Ring wave Direct

A coupling capacitor of 0.33uF is already included in the impulse generator. With the direct line, it is possible to add an additional user defined coupling element (for example a gas discharge tube or a diode with a different value).



With the ADAPTER BOX 90VG coupling via Gas Discharge Tube (GDT) is possible. It is part of the standard accessory and contains a 90V GDT.

2. Ring wave with a 33V bipolar diode

3. Surge Direct

Add a user defined coupling element (for example a gas discharge tube or a diode with a different value). 18uF coupling capacitor is build into the generator.



With the ADAPTER BOX 90VG coupling via Gas Discharge Tube (GDT) is possible. It is part of the standard accessory and contains a 90V GDT.

4. Surge with a 0.5uF coupling capacitor

5. Surge with a 33V bipolar diode

4 Coupling

Selection of the coupling path. Only one path to high and low at once.

5 Equipment Under Test (EUT)

Equipment subjected to the disturbance signal, should be connected to the output port of the coupling network.

6 Auxiliary Equipment (AE)

Equipment that is necessary for setting up all functions and assessing the correct performance of the EUT during the test.

19.2.2

Calibration Setup

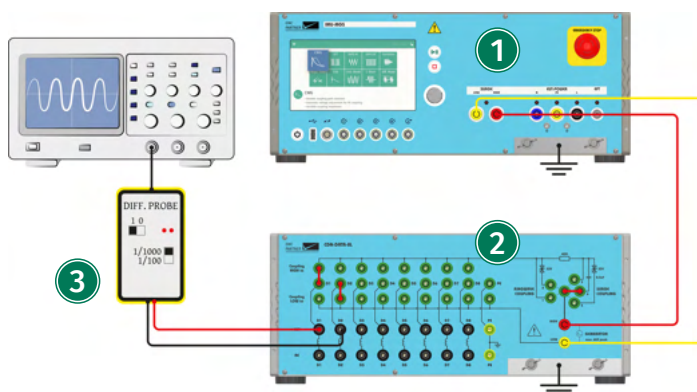

IMU-MGS or IMU-MGE - CDN-DATA-4L or CDN-DATA-8L - V-PROBE-SI

1 Generator

On your IMU-MGS generator select the "Surge" immunity test, on your IMU-MGE generator you can select the "Surge" or "Ring Wave" immunity test and set the test parameters according to your needs. Select the (Coupling) menu tab, and set "Device" to CDN-DATA-8L and "Coupling" to Impulse Out.

2 CDN

Connect the Surge direct output (LOW and HIGH) of the generator to the generator input (LOW and HIGH) at the CDN using a 1m twisted pair cable. Select the coupling device according to your needs and select the coupling (LOW or HIGH to individual lines) according to your needs.

3 Measurement

Connect a differential probe with sufficient specifications, e.g. V-PROBE-SI, to the lines you want to calibrate at the output port of your CDN.

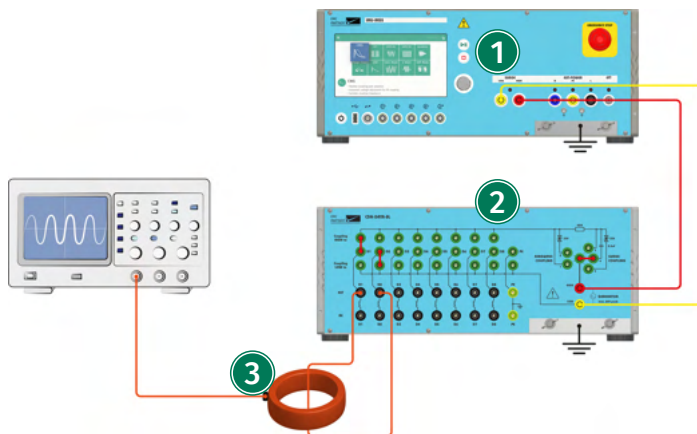

IMU-MGS or IMU-MGE - CDN-DATA-4L or CDN-DATA-8L - I-PROBE-P101

1 Generator

On your IMU-MGS generator select the "Surge" immunity test, on your IMU-MGE generator you can select the "Surge" or "Ring Wave" immunity test and set the test parameters according to your needs. Select the (Coupling) menu tab, and set "Device" to CDN-DATA-8L and "Coupling" to Impulse Out.

2 CDN

Connect the Surge direct output (LOW and HIGH) of the generator to the generator input (LOW and HIGH) at the CDN using a 1m twisted pair cable. Select the coupling device according to your needs and select the coupling (LOW or HIGH to individual lines) according to your needs.

3 Measurement

Connect a current probe with sufficient specifications, e.g. I-PROBE-P101, to the lines to be calibrated at the output port of your CDN.

19.3 CDN-UTP ED3

The CDN-UTP ED3 is a manual CDN that can be used with EMC PARTNER IMU-MGS and IMU-MGE generators for Surge tests in order to superpose pulses on unshielded twisted signal and data lines, in accordance with the latest editions of IEC 61000-4-5. The CDN addresses 2 twisted pair lines (4 wires) for Common Mode testing or 2 asymmetrical lines for Differential Mode testing.

19.3.1 Hardware Description

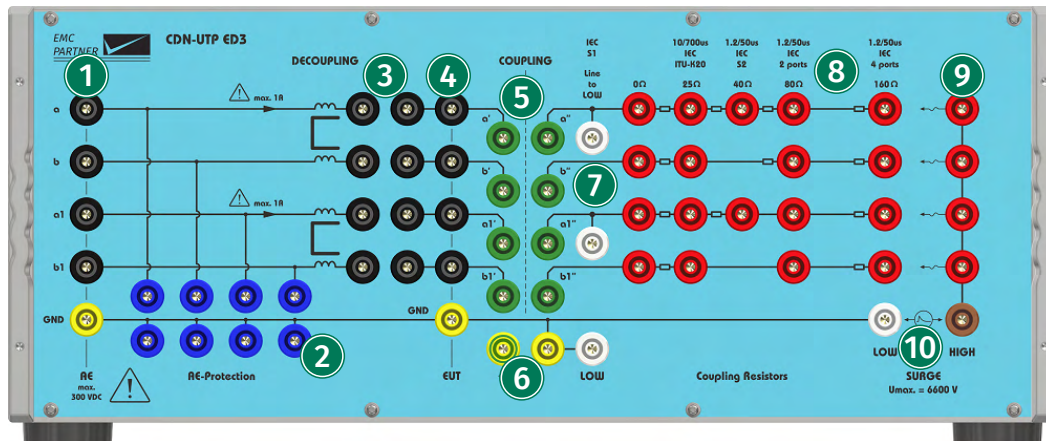

- 1 Auxiliary Equipment (AE) Input Connectors**
Input connectors for 4 data lines (2 symmetric pairs) of the auxiliary equipment (AE).
- 2 AE-Protection Device Connectors**
The connectors allow the user to connect additional protection devices between the individual data lines and PE.
- 3 Path Enable/Disable Connectors**
These connectors allow the user to enable or disable the decoupling part of individual lines. They also allow you to connect your AE directly to the decoupling part of the CDN, and bypassing the decoupling inductors.
- 4 Equipment Under Test (EUT) Output Connectors**
Output connectors for 4 data lines (2 symmetric pairs) of the EUT.
- 5 Coupling Path Selection**
The connectors allow you to enable or disable the coupling to individual data lines, by placing bridges accordingly.
- 6 Low-to-PE Connectors**
By placing a bridge between these two connectors, you can connect LOW to PE.
- 7 Line-to-Low Connectors**
These connectors allow you to bind individual data lines to LOW.
- 8 Coupling Resistors Selection Matrix**
This connector matrix allows you to select the appropriate coupling resistance according to the number of lines you are coupling to. Selectable values are 0 Ohm, 25 Ohm, 40 Ohm, 80 Ohm, and 160 Ohm.
- 9 HIGH-to-Line Connectors**
Connect HIGH to the individual lines you want to couple to by connecting these connectors to the appropriate PE connectors in the coupling resistors selection matrix.
- 10 Surge Generator Input Connectors**
Input connectors for the generator Surge direct output (LOW and HIGH).

19.3.2 Test Setup CDN-UTP ED3 on Unsymmetrical Data Lines

The following test setup can be used for equipment with asymmetrical data lines.

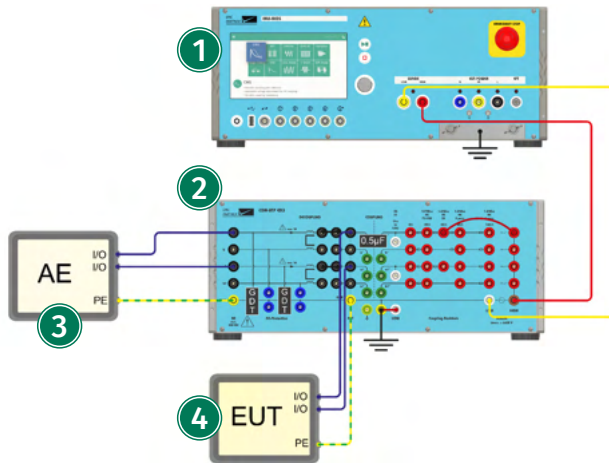

IMU-MGS or IMU-MGE - CDN-UTP ED3

1 Generator

On your IMU-MGS generator select the "Surge" immunity test, on your IMU-MGE generator you can select the "Surge", "Telecom", or "Ring Wave" immunity test and set the test parameters according to your needs. Select the (Coupling) menu tab, and set "Device" to CDN-UTP ED3 and "Coupling" to Impulse Out.



When performing a Telecom test with the IMU-MGE, the output impedance should be set to 15 Ohm.

When performing a Ringwave test with the IMU-MGE, the output impedance should be set to 30 Ohm.

2 CDN

Connect the Surge direct output (LOW and HIGH) of the generator to the generator input (LOW and HIGH) at the CDN using a 1 m twisted pair cable.

According to your needs, connect HIGH to the resistor values in the coupling resistor selection matrix using a short cable, on the one data line you want to test.

Connect LOW to PE (according to your needs).

Place a coupling device, e.g. a 0.5 uF capacitor, in the "COUPLING" part of the CDN, on the one line you want to test.

Place AE protection devices, e.g. GDTs, on the lines you want to protect from being subjected to the Surge test.

Enable the data lines, by placing connector bridges on those lines, in the "DECOUPLING" part of the CDN.

Connect the auxiliary equipment (AE) with up to 2 asymmetrical data lines and a PE connection to the AE connectors of the CDN.

Connect the equipment under test (EUT) with up to 2 asymmetrical data lines and a PE connection to the EUT connectors of the CDN.

3 Auxiliary Equipment (AE)

Equipment that is necessary for setting up all functions and assessing the correct performance of the EUT during the test.

4 Equipment Under Test (EUT)

Equipment subjected to the disturbance signal, should be connected to the output port of the coupling network. EUTs with up to 4 data lines (2 symmetrical twisted pairs) or 2 asymmetrical data lines can be tested.

19.3.3 Test Setup CDN-UTP ED3 on Symmetrical Data Lines

The following test setup can be used for equipment with two pairs of symmetrical data lines.

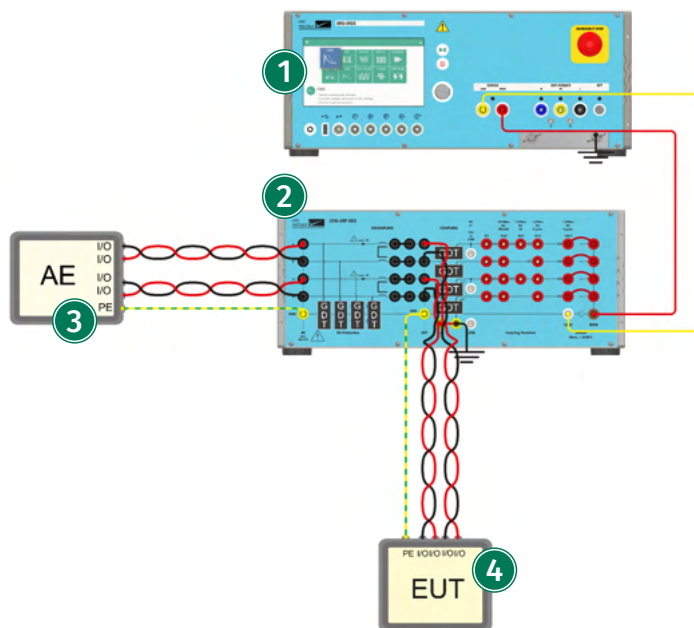

IMU-MGS or IMU-MGE - CDN-UTP ED3

1 Generator

On your IMU-MGS generator select the "Surge" immunity test, on your IMU-MGE generator you can select the "Surge", "Telecom", or "Ring Wave" immunity test and set the test parameters according to your needs. Select the (Coupling) menu tab, and set "Device" to CDN-UTP ED3 and "Coupling" to Impulse Out.



When performing a Telecom test with the IMU-MGE, the output impedance should be set to 15 Ohm.

When performing a Ringwave test with the IMU-MGE, the output impedance should be set to 30 Ohm.

2 CDN

Connect the Surge direct output (LOW and HIGH) of the generator to the generator input (LOW and HIGH) at the CDN using a 1 m twisted pair cable.

According to your needs, connect HIGH to the resistor values in the coupling resistor selection matrix using short cables.

Connect LOW to PE (according to your needs).

Place coupling devices, e.g. gas discharge tubes (GDTs), in the "COUPLING" part of the CDN, on the lines you want to test.

Place AE protection devices, e.g. GDTs, on the lines you want to test to protect your auxiliary equipment from being subjected to the Surge test.

Enable the data lines you want to test, by placing connector bridges on those lines, in the "DECOUPLING" part of the CDN.

Connect the auxiliary equipment (AE) with up to 4 data lines (2 twisted pairs) and a PE connection to the AE connectors of the CDN.

Connect the equipment under test (EUT) with up to 4 data lines (2 twisted pairs) and a PE connection to the EUT connectors of the CDN.

3 Auxiliary Equipment (AE)

Equipment that is necessary for setting up all functions and assessing the correct performance of the EUT during the test.

4 Equipment Under Test (EUT)

Equipment subjected to the disturbance signal, should be connected to the output port of the coupling network. EUTs with up to 4 data lines (2 symmetrical twisted pairs) can be tested.

19.3.4 Calibration Setup CDN-UTP ED3 on Unsymmetrical Data Lines

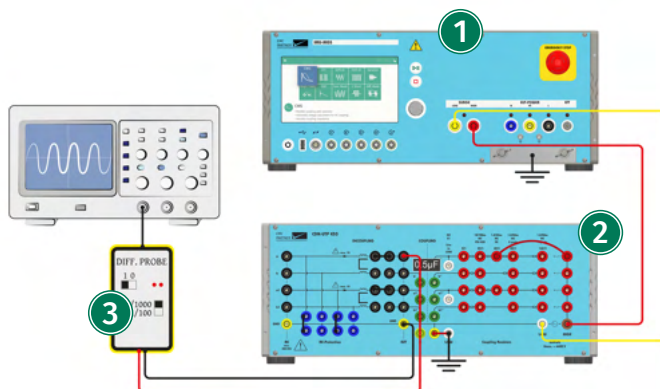

IMU-MGS or IMU-MGE - CDN-UTP ED3 - V-PROBE-SI

1 Generator

On your IMU-MGS generator select the "Surge" immunity test, on your IMU-MGE generator you can select the "Surge", "Telecom", or "Ring Wave" immunity test and set the test parameters according to your needs. Select the (Coupling) menu tab, and set "Device" to CDN-UTP ED3 and "Coupling" to Impulse Out.



When performing a Telecom test with the IMU-MGE, the output impedance should be set to 15 Ohm.

When performing a Ringwave test with the IMU-MGE, the output impedance should be set to 30 Ohm.

2 CDN

Connect the generator Surge direct output (LOW and HIGH) to the Surge generator input on the CDN using a 1 m twisted pair cable.

According to your needs, connect HIGH on the right side of the CDN to the appropriate resistor

value in the resistor selection matrix using a short cable.

Place a 0.5 uF coupling capacitor as a coupling devices in the connectors of the coupling part of the CDN.

Enable the line to be calibrated by placing connector bridges in the connectors of the decoupling part of the CDN.

Place connector bridges in the "AE protection device" connectors to bind the input part of the CDN to GND (this needs only to be done for calibration).

Connect LOW to PE.

3 Measurement

Connect a differential probe with sufficient specifications, e.g. V-PROBE-SI, at the output port of the CDN between the line to be calibrated and GND.

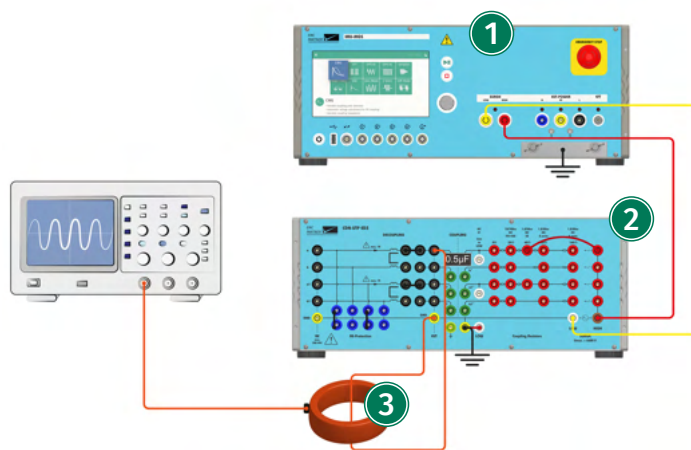

IMU-MGS or IMU-MGE - CDN-UTP ED3 - I-PROBE-P101

1 Generator

On your IMU-MGS generator select the "Surge" immunity test, on your IMU-MGE generator you can select the "Surge", "Telecom", or "Ring Wave" immunity test and set the test parameters according to your needs. Select the (Coupling) menu tab, and set "Device" to CDN-UTP ED3 and "Coupling" to Impulse Out.



When performing a Telecom test with the IMU-MGE, the output impedance should be set to 15 Ohm.

When performing a Ringwave test with the IMU-MGE, the output impedance should be set to 30 Ohm.

2 CDN

Connect the generator Surge direct output (LOW and HIGH) to the Surge generator input on the CDN using a 1 m twisted pair cable.

According to your needs, connect HIGH on the right side of the CDN to the appropriate resistor value in the resistor selection matrix using a short cable.

Place a 0.5 uF coupling capacitor as a coupling devices in the connectors of the coupling part of the CDN.

Enable the line to be calibrated by placing connector bridges in the connectors of the decoupling part of the CDN.

Place connector bridges in the "AE protection device" connectors to bind the input part of the

CDN to GND (this needs only to be done for calibration).
Connect LOW to PE.

3 Measurement

Connect a current probe with sufficient specifications, e.g. I-PROBE-P101, between the EUT output line to be calibrated and GND on your CDN.

19.3.5 Calibration Setup CDN-UTP ED3 on Symmetrical Data Lines

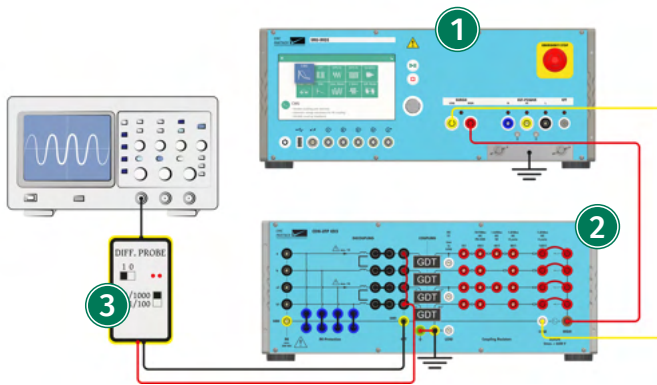

IMU-MGS or IMU-MGE - CDN-UTP ED3 - V-PROBE-SI

1 Generator

On your IMU-MGS generator select the "Surge" immunity test, on your IMU-MGE generator you can select the "Surge", "Telecom", or "Ring Wave" immunity test and set the test parameters according to your needs. Select the (Coupling) menu tab, and set "Device" to CDN-UTP ED3 and "Coupling" to Impulse Out.



When performing a Telecom test with the IMU-MGE, the output impedance should be set to 15 Ohm.
When performing a Ringwave test with the IMU-MGE, the output impedance should be set to 30 Ohm.

2 CDN

Connect the generator Surge direct output (LOW and HIGH) to the Surge generator input on the CDN.

According to your needs, connect HIGH on the right side of the CDN to the appropriate resistor value in the resistor selection matrix using short cables.

Place gas discharge tubes (GDT) as coupling devices in the connectors of the coupling part of the CDN.

Short-circuit all EUT output lines to be calibrated using short cables.

Enable all lines to be calibrated by placing connector bridges in the connectors of the decoupling part of the CDN.

Place connector bridges in the "AE protection device" connectors to bind the input part of the CDN to GND (this needs only to be done for calibration).

Connect LOW to PE.

3 Measurement

Connect a differential probe with sufficient specifications, e.g. V-PROBE-SI, at the output port of the CDN between the short-circuited EUT output lines and GND.

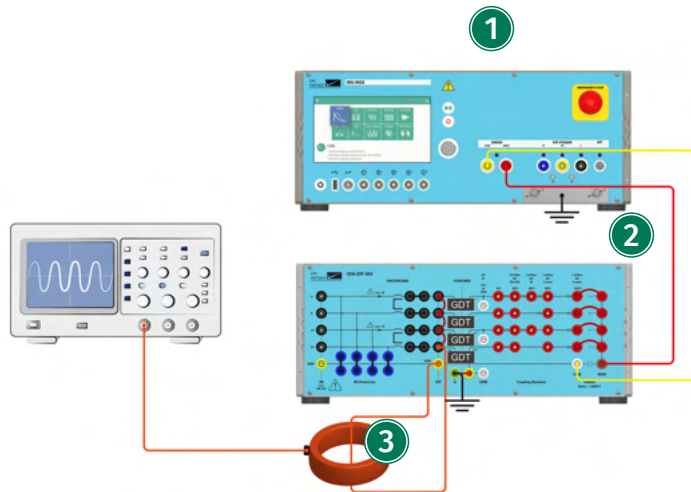

IMU-MGS or IMU-MGE - CDN-UTP ED3 - I-PROBE-P101

1 Generator

On your IMU-MGS generator select the "Surge" immunity test, on your IMU-MGE generator you can select the "Surge", "Telecom", or "Ring Wave" immunity test and set the test parameters according to your needs. Select the (Coupling) menu tab, and set "Device" to CDN-UTP ED3 and "Coupling" to Impulse Out.



When performing a Telecom test with the IMU-MGE, the output impedance should be set to 15 Ohm.

When performing a Ringwave test with the IMU-MGE, the output impedance should be set to 30 Ohm.

2 CDN

Connect the generator Surge direct output (LOW and HIGH) to the Surge generator input on the CDN using a 1 m twisted pair cable.

According to your needs, connect HIGH on the right side of the CDN to the appropriate resistor value in the resistor selection matrix using short cables.

Place gas discharge tubes (GDT) as coupling devices in the connectors of the coupling part of the CDN.

Short-circuit all EUT output lines to be calibrated using short cables.

Enable all lines to be calibrated by placing connector bridges in the connectors of the decoupling part of the CDN.

Place connector bridges in the "AE protection device" connectors to bind the input part of the CDN to GND (this needs only to be done for calibration).

Connect LOW to PE.

3 Measurement

Connect a current probe with sufficient specifications, e.g. I-PROBE-P101, between the short-circuited EUT output lines and GND on your CDN.

1 Generator

On your IMU-MGS generator select the "Surge" immunity test, on your IMU-MGE generator you can select the "Surge", "Telecom", or "Ring Wave" immunity test and set the test parameters according to your needs. Select the (Coupling) menu tab, and set "Device" to CDN-UTP8 ED3 and "Coupling" to Impulse Out.



When performing a Telecom test with the IMU-MGE, the output impedance should be set to 15 Ohm.

When performing a Ringwave test with the IMU-MGE, the output impedance should be set to 30 Ohm.

2 CDN

Connect the Surge direct output (LOW and HIGH) of the generator to the generator input (LOW and HIGH) at the CDN using a 1 m twisted pair cable.

According to your needs, connect HIGH to the resistor values in the coupling resistor selection matrix using a short cable, on the one data line you want to test.

Connect LOW to PE (according to your needs).

Place a coupling device, e.g. a 0.5 uF capacitor, in the "COUPLING" part of the CDN, on the one line you want to test.

Place AE protection devices, e.g. GDTs, on the lines you want to protect from being subjected to the Surge test.

Enable the data lines, by placing connector bridges on those lines, in the "DECOUPLING" part of the CDN.

Connect the auxiliary equipment (AE) with up to 4 asymmetrical data lines and a PE connection to the AE connectors of the CDN.

Connect the equipment under test (EUT) with up to 4 asymmetrical data lines and a PE connection to the EUT connectors of the CDN.

3 Auxiliary Equipment (AE)

Equipment that is necessary for setting up all functions and assessing the correct performance of the EUT during the test.

4 Equipment Under Test (EUT)

Equipment subjected to the disturbance signal, should be connected to the output port of the coupling network. EUTs with up to 8 data lines (4 symmetrical twisted pairs) or 4 asymmetrical data lines can be tested.

19.4.3 Test Setup CDN-UTP8 ED3 on Symmetrical Data Lines

The following test setup can be used for equipment with four pairs of symmetrical data lines, directly connected to the CDN.

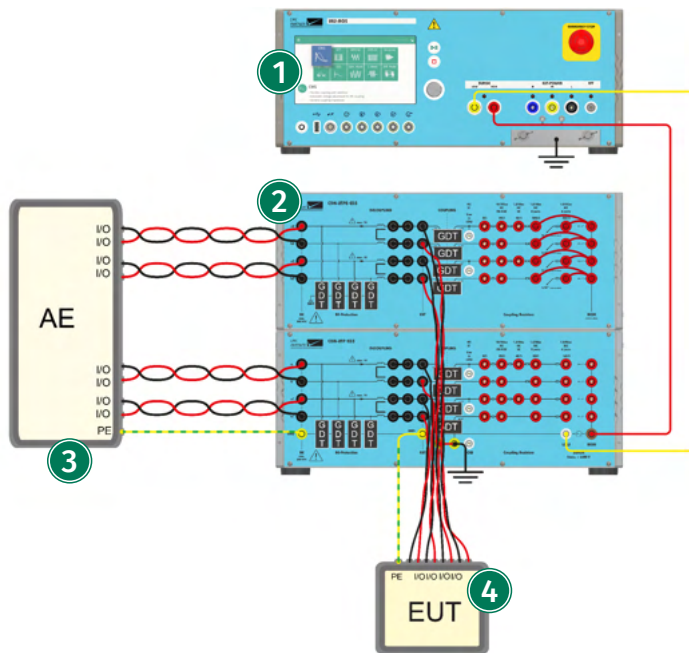

IMU-MGS or IMU-MGE - CDN-UTP8 ED3

1 Generator

On your IMU-MGS generator select the "Surge" immunity test, on your IMU-MGE generator you can select the "Surge", "Telecom", or "Ring Wave" immunity test and set the test parameters according to your needs. Select the (Coupling) menu tab, and set "Device" to CDN-UTP8 ED3 and "Coupling" to Impulse Out.



When performing a Telecom test with the IMU-MGE, the output impedance should be set to 15 Ohm.

When performing a Ringwave test with the IMU-MGE, the output impedance should be set to 30 Ohm.

2 CDN

Connect the Surge direct output (LOW and HIGH) of the generator to the generator input (LOW and HIGH) at the CDN using a 1 m twisted pair cable.

According to your needs, connect HIGH to the resistor values in the coupling resistor selection matrix using short cables.

Connect LOW to PE (according to your needs).

Place coupling devices, e.g. gas discharge tubes (GDTs), in the "COUPLING" part of the CDN, on the lines you want to test.

Place AE protection devices, e.g. GDTs, on the lines you want to test to protect your auxiliary equipment from being subjected to the Surge test.

Enable the data lines you want to test, by placing connector bridges on those lines, in the "DECOUPLING" part of the CDN.

Connect the auxiliary equipment (AE) with up to 8 data lines (4 twisted pairs) and a PE connection to the AE connectors of the CDN.

Connect the equipment under test (EUT) with up to 8 data lines (4 twisted pairs) and a PE connection to the EUT connectors of the CDN.

3 Auxiliary Equipment (AE)

Equipment that is necessary for setting up all functions and assessing the correct performance of the EUT during the test.

4 Equipment Under Test (EUT)

Equipment subjected to the disturbance signal, should be connected to the output port of the coupling network. EUTs with up to 8 data lines (4 symmetrical twisted pairs) can be tested.

For equipment with Ethernet connectors, i.e. RJ45 connectors, special adapters are available. The following pictures show the CDN-UTP8-ED3 configuration, first without the adapters and connections to the AE and EUT, then how the RJ45 adapters should be connected, and lastly the complete test setup.

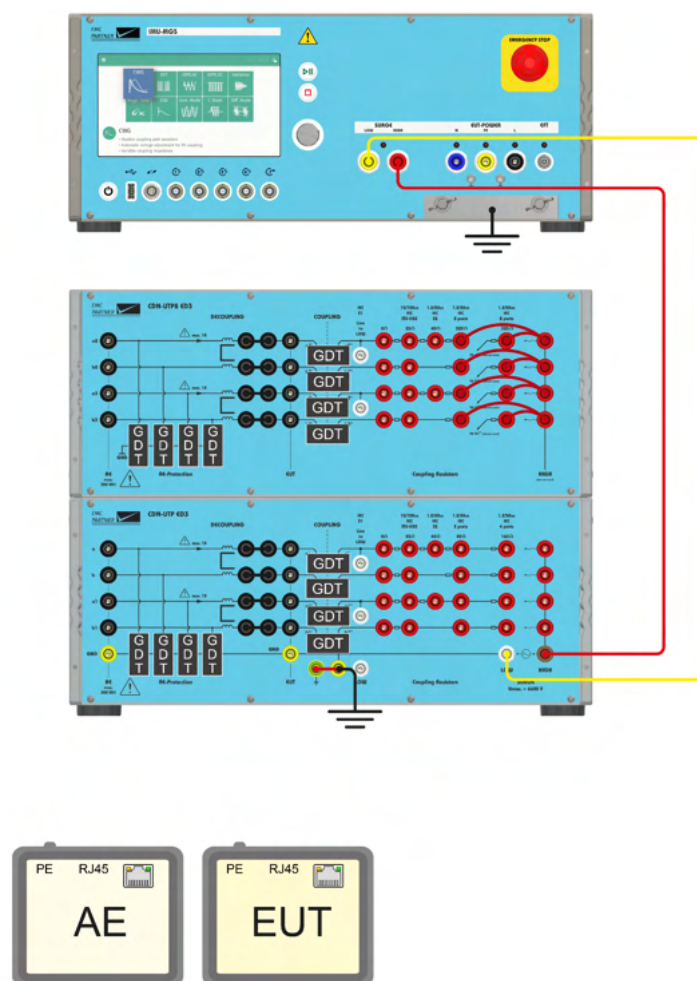

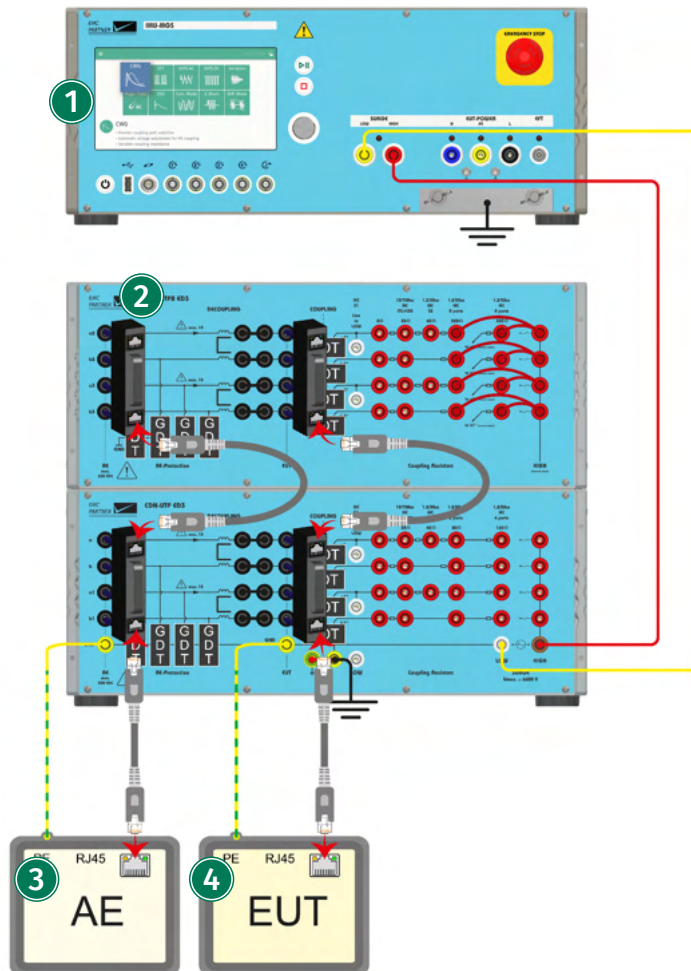
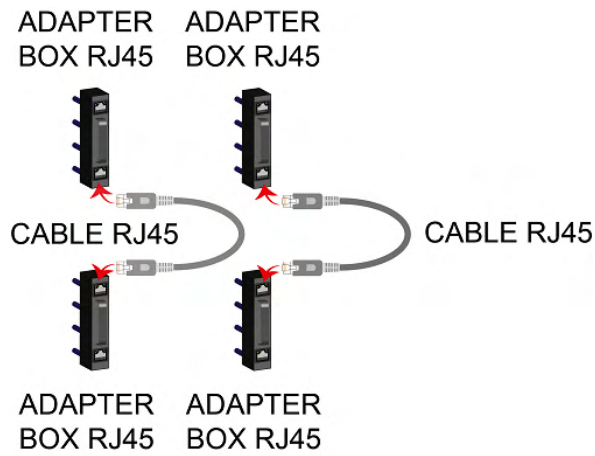

IMU-MGS or IMU-MGE - CDN-UTP8 ED3 - ADAPTER BOX RJ45

1 Generator

On your IMU-MGS generator select the "Surge" immunity test, on your IMU-MGE generator you can select the "Surge", "Telecom", or "Ring Wave" immunity test and set the test parameters

according to your needs. Select the (Coupling) menu tab, and set "Device" to CDN-UTP8 ED3 and "Coupling" to Impulse Out.



When performing a Telecom test with the IMU-MGE, the output impedance should be set to 15 Ohm.

When performing a Ringwave test with the IMU-MGE, the output impedance should be set to 30 Ohm.

② CDN

Connect the Surge direct output (LOW and HIGH) of the generator to the generator input (LOW and HIGH) at the CDN using a 1 m twisted pair cable.

According to your needs, connect HIGH to the resistor values in the coupling resistor selection matrix using short cables.

Connect LOW to PE (according to your needs).

Place coupling devices, e.g. gas discharge tubes (GDTs), in the "COUPLING" part of the CDN, on all the lines.

Place AE protection devices, e.g. GDTs, on all the lines to protect your auxiliary equipment from being subjected to the Surge test.

Enable all data lines, by placing connector bridges on those lines, in the "DECOUPLING" part of the CDN.

Place two RJ45 ADAPTERS on the CDN AE inputs. Place two RJ45 ADAPTERS on the CDN EUT outputs. Connect the RJ45 ADAPTERS for all eight data lines.

Connect the auxiliary equipment (AE) to the CDN using a standard Ethernet cable consisting of 8 data lines (4 twisted pairs).

Connect the equipment under test (EUT) using a standard Ethernet cable consisting of 8 data lines (4 twisted pairs).

③ Auxiliary Equipment (AE)

Equipment that is necessary for setting up all functions and assessing the correct performance of the EUT during the test.

④ Equipment Under Test (EUT)

Equipment subjected to the disturbance signal, should be connected to the output port of the coupling network. EUTs with up to 8 data lines (4 symmetrical twisted pairs) can be tested.

19.4.4 Calibration Setup CDN-UTP8 ED3 on Unsymmetrical Data Lines

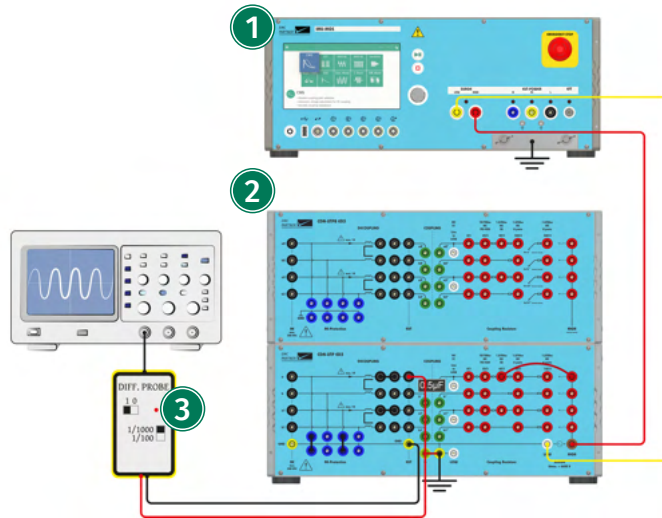

IMU-MGS or IMU-MGE - CDN-UTP8 ED3 - V-PROBE-SI

1 Generator

On your IMU-MGS generator select the "Surge" immunity test, on your IMU-MGE generator you can select the "Surge", "Telecom", or "Ring Wave" immunity test and set the test parameters according to your needs. Select the (Coupling) menu tab, and set "Device" to CDN-UTP8 ED3 and "Coupling" to Impulse Out.



When performing a Telecom test with the IMU-MGE, the output impedance should be set to 15 Ohm.

When performing a Ringwave test with the IMU-MGE, the output impedance should be set to 30 Ohm.

2 CDN

Connect the generator Surge direct output (LOW and HIGH) to the Surge generator input on the CDN using a 1 m twisted pair cable.

According to your needs, connect HIGH on the right side of the CDN to the appropriate resistor value in the resistor selection matrix using a short cable.

Place a 0.5 uF coupling capacitor as a coupling devices in the connectors of the coupling part of the CDN.

Enable the line to be calibrated by placing connector bridges in the connectors of the decoupling part of the CDN.

Place connector bridges in the "AE protection device" connectors to bind the input part of the CDN to GND (this needs only to be done for calibration).

Connect LOW to PE.

3 Measurement

Connect a differential probe with sufficient specifications, e.g. V-PROBE-SI, at the output port of the CDN between the line to be calibrated and GND.

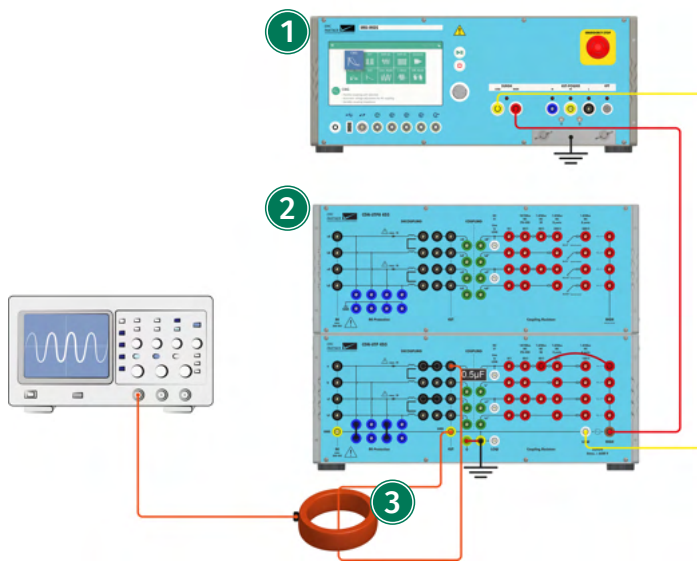

IMU-MGS or IMU-MGE - CDN-UTP8 ED3 - I-PROBE-P101

1 Generator

On your IMU-MGS generator select the "Surge" immunity test, on your IMU-MGE generator you can select the "Surge", "Telecom", or "Ring Wave" immunity test and set the test parameters according to your needs. Select the (Coupling) menu tab, and set "Device" to CDN-UTP8 ED3 and "Coupling" to Impulse Out.



When performing a Telecom test with the IMU-MGE, the output impedance should be set to 15 Ohm.

When performing a Ringwave test with the IMU-MGE, the output impedance should be set to 30 Ohm.

2 CDN

Connect the generator Surge direct output (LOW and HIGH) to the Surge generator input on the CDN using a 1 m twisted pair cable.

According to your needs, connect HIGH on the right side of the CDN to the appropriate resistor value in the resistor selection matrix using a short cable.

Place a 0.5 uF coupling capacitor as a coupling devices in the connectors of the coupling part of the CDN.

Enable the line to be calibrated by placing connector bridges in the connectors of the decoupling part of the CDN.

Place connector bridges in the "AE protection device" connectors to bind the input part of the CDN to GND (this needs only to be done for calibration).

Connect LOW to PE.

3 Measurement

Connect a current probe with sufficient specifications, e.g. I-PROBE-P101, between the EUT output line to be calibrated and GND on your CDN.

19.4.5 Calibration Setup CDN-UTP8 ED3 on Symmetrical Data Lines

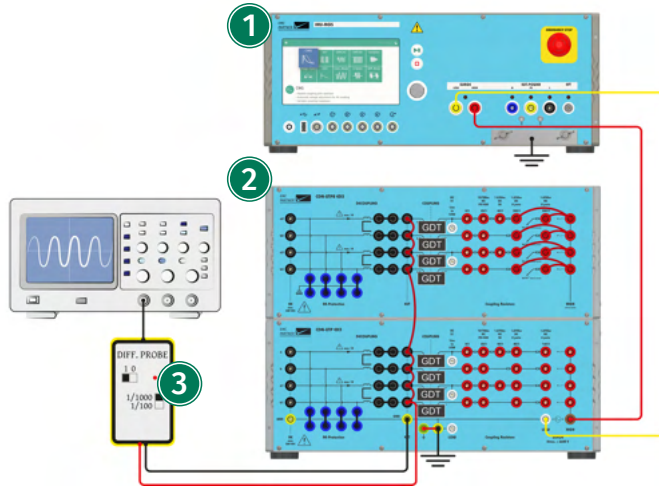

IMU-MGS or IMU-MGE - CDN-UTP8 ED3 - V-PROBE-SI

1 Generator

On your IMU-MGS generator select the "Surge" immunity test, on your IMU-MGE generator you can select the "Surge", "Telecom", or "Ring Wave" immunity test and set the test parameters according to your needs. Select the (Coupling) menu tab, and set "Device" to CDN-UTP8 ED3 and "Coupling" to Impulse Out.



When performing a Telecom test with the IMU-MGE, the output impedance should be set to 15 Ohm.

When performing a Ringwave test with the IMU-MGE, the output impedance should be set to 30 Ohm.

2 CDN

Connect the generator Surge direct output (LOW and HIGH) to the Surge generator input on the CDN using a 1 m twisted pair cable.

According to your needs, connect HIGH on the right side of the CDN to the appropriate resistor value in the resistor selection matrix using short cables.

Place gas discharge tubes (GDT) as coupling devices in the connectors of the coupling part of the CDN.

Short-circuit all EUT output lines to be calibrated using short cables.

Enable all lines to be calibrated by placing connector bridges in the connectors of the decoupling part of the CDN.

Place connector bridges in the "AE protection device" connectors to bind the input part of the CDN to GND (this needs only to be done for calibration).

Connect LOW to PE.

3 Measurement

Connect a differential probe with sufficient specifications, e.g. V-PROBE-SI, at the output port of the CDN between the short-circuited EUT output lines and GND.

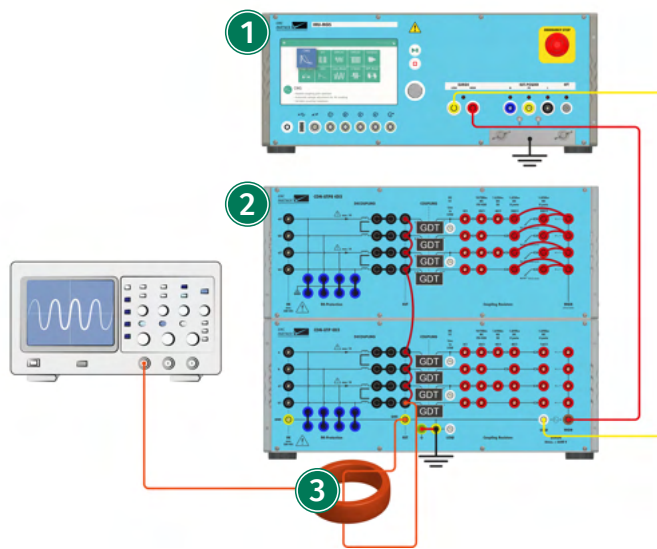

IMU-MGS or IMU-MGE - CDN-UTP8 ED3 - I-PROBE-P101

1 Generator

On your IMU-MGS generator select the "Surge" immunity test, on your IMU-MGE generator you can select the "Surge", "Telecom", or "Ring Wave" immunity test and set the test parameters according to your needs. Select the (Coupling) menu tab, and set "Device" to CDN-UTP8 ED3 and "Coupling" to Impulse Out.



When performing a Telecom test with the IMU-MGE, the output impedance should be set to 15 Ohm.

When performing a Ringwave test with the IMU-MGE, the output impedance should be set to 30 Ohm.

2 CDN

Connect the generator Surge direct output (LOW and HIGH) to the Surge generator input on the CDN using a 1 m twisted pair cable.

According to your needs, connect HIGH on the right side of the CDN to the appropriate resistor value in the resistor selection matrix using short cables.

Place gas discharge tubes (GDT) as coupling devices in the connectors of the coupling part of the CDN.

Short-circuit all EUT output lines to be calibrated using short cables.

Enable all lines to be calibrated by placing connector bridges in the connectors of the decoupling part of the CDN.

Place connector bridges in the "AE protection device" connectors to bind the input part of the CDN to GND (this needs only to be done for calibration).

Connect LOW to PE.

3 Measurement

Connect a current probe with sufficient specifications, e.g. I-PROBE-P101, between the short-circuited EUT output lines and GND on your CDN.

20 Remote Operation

The latest test protocols can be accessed quickly using the internal webserver. Access is through any common web browser and is totally independent of any operating system. In the web browser, enter only the address `http://<ip-address>`



The factory default IP address is 192.168.0.150

A programmer manual is available upon request.

20.1 TEMA3000

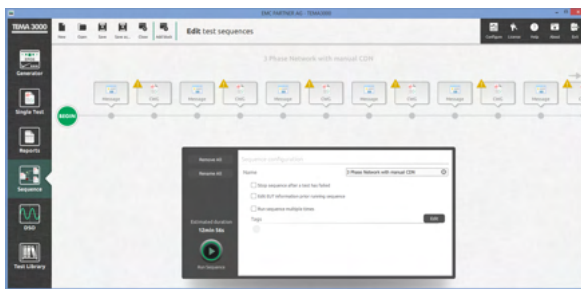

TEMA3000 is a forward looking software suite designed to run on operating systems from Windows 7 and upwards. Graphic user interface with icons to simplify operation. Parameter entry through Remote EMC PARTNER Operating System (REPOS) interface reduces learning time for users familiar with the generator hardware. TEMA3000 base version includes generator remote control interface and single test capability, save and recall of files and a comprehensive help file. Test routines can be prepared in TEMA3000 and then uploaded into the generator in the test lab. Programming with the REPOS interface is exactly the same as sitting in front of a generator. Report generation in TEMA3000 base version is through the Web Server in the generator or the generator USB port.

Main features of TEMA3000 are

- Remote control of generator
- Save single tests
- Combine different tests to a test sequence with pictures about test setups and additional help for test operator
- Outstanding protocol features including export in different file formats
- Easy to use test library with hundreds of tests
- Seamless integration of your DSO

Get in touch with your local representative or directly with EMC PARTNER for more information about TEMA3000.



Go to www.emc-partner.com for a free software demo version.

21 Maintenance and Service

21.1 Firmware update

Keeping test instrumentation up to date is an important part of the product life cycle. EMC PARTNER makes continuous improvements to all products. This can be in the form of hardware changes or software changes. Software updates for all instruments are provided free of charge to existing customers. EMC PARTNER recommends to update the system regularly.

Online Update

Select ≡ (Options Menu) → Update

The easiest way if the generator is connected to the internet. If a newer version is available, the installation is made with a single click.

Update via USB

You can also download the newest version from www.emc-partner.com. Store the update file on a USB-Stick and transfer into the equipment via the USB port on the front panel. The update process starts automatically.



Do not switch off the generator during a firmware update

21.2 Maintenance

21.3 Cleaning

Cleaning the front and rear panels can be made with small amount of warm soapy water and a soft cloth. The display can be cleaned with a cleaning tissue. EMC PARTNER recommends that the air filter of the ventilator be cleaned from time to time. The cleaning cycle depends on the environmental conditions. Wash out the air filter of the ventilator in soapy water. The air filter must be dried before being reinstalled.

21.4 Warranty

EMC PARTNER's warranty is two years from date of invoice for manufacturing defects and one year from date of invoice for consumable parts, e.g. relays, capacitors, variac, connectors. During the warranty period it is EMC PARTNER's goal to repair the equipment within one working week at the service plant in Laufen, Switzerland. However, due to excessive work load or component supply deliveries this repair time may be extended. The warranty on demo equipment is limited in all cases to a maximum period of 2 years after delivery ex works (see EMC PARTNER Invoice date). For sales by sub-resellers or rental companies, the warranty will not be extended. Shipping expenses "Customer to EMC PARTNER" must be paid by customer or reseller. Return shipments "EMC PARTNER to Customer" are sent DAP delivery address using normal road transport for all destinations within Europe or CIP destination airport by airfreight through our house forwarder for all over-sea shipments. Additional costs for express delivery must be borne by the customer. Return of EMC PARTNER's equipment for warranty repair is at the sole discretion of EMC PARTNER's Customer service department. An RMA number has to be requested from EMC PARTNER before sending any equipment back to Switzerland. EMC PARTNER reserves the right to reject or invoice repairs on equipment returned for repair without such authorization.

21.5 Customer Service

EMC PARTNER is an international organization with designated service centres in all major markets. When any of the following occur:

- Accessories or replacement parts are needed
- Questions arise that are not covered in the user manual
- The equipment must be recalibrated
- The equipment needs repairing

contact the local EMC PARTNER representative or service centre. If the local contact is not known, check the internet site www.emc-partner.com and select contacts. If there is no local organization, contact EMC PARTNER headquarters in Switzerland. Our contact details are also given on the web site.

Whenever further assistance is required, provide as much data as possible to help with a speedy solution. Service relevant information (system configuration, error logs, etc.) is collected by the equipment. This information can be very helpful in providing an early solution. Copy service information to a USB memory stick as follows:

- Plug in a USB stick
- Select ≡ (General Menu) → Generator
- In the tab Help select Copy to USB

The information is transferred to the root folder of the USB. Send file by e-mail to service@emc-partner.ch

21.6 Recycling / Disposal

RoHS directive 2011/65/EU

The system complies with the directive 2011/65/EU (RoHS - Restriction of certain Hazardous Substances). From December 2005, all EMC PARTNER products either hand soldered or by machine are produced using lead-free solder.

WEEE directive 2012/19/EU

The system is exempted from the directive 2012/19/EU (WEEE) under category 9. The product should be recycled through a professional organization with appropriate experience for the disposal and recycling of electronic products. EMC PARTNER is also available to help with questions relating to the recycling of this product.

Dismantling

There is no special danger involved in dismantling.

Parts which can be recycled

The system contains parts made from steel, aluminium, PVC, two-component sealing compound. The impulse capacitors are filled with non-poisonous mineral oil. The various parts can be separated and recycled.

Parts which cannot be recycled

None

22 Technical Data

22.1 IMU-MGS

22.1.1 EUT Power Management

EUT Power ¹

Power input 1	max. 300 V / 16 A fused
Power input 2	max. 300 V / 16 A unfused
Frequency	DC - 60 Hz

Internal Variac

Input Voltage	20 - 250 V
Frequency	50/60 Hz
Output Voltage at no load	0 - 100% of $V_{in} \pm 5\%$
Continuous Output Current	5 A @100 %
Voltage Slew Rate	<1 s from 0 - 100 %

Power Switch	manual automatic
---------------------	---------------------

Measurement	Voltage Current
--------------------	--------------------

On / Off Synchronisation ²	0 - 359°
--	----------

EUT overcurrent protection	programmable fuse
-----------------------------------	-------------------

22.1.2 EFT

Module EXT-IMU4000 F or EXT-IMU4000 F5 required.

Standard	IEC 61000-4-4
-----------------	---------------

Output Impedance	50 Ω
-------------------------	-------------

Open circuit Level

EXT-IMU4000 F	200 V - 4400 V
---------------	----------------

EXT-IMU4000 F5	200 V - 5100 V
----------------	----------------

Waveshape into 50 Ω

Level

EXT-IMU4000 F	100 V - 2200 V $\pm 10\%$
---------------	---------------------------

EXT-IMU4000 F5	100 V - 2550 V $\pm 10\%$
----------------	---------------------------

Rise time

Direct Output	5 ns ± 1.5 ns
---------------	-------------------

Internal CDN	5.5 ns ± 1.5 ns
--------------	---------------------

Duration	50 ns ± 15 ns
-----------------	-------------------

Waveshape into 1 k Ω

Level

EXT-IMU4000 F4	191 V - 4190 V $\pm 20\%$
----------------	---------------------------

EXT-IMU4000 F5	191 V - 4857 V $\pm 20\%$
----------------	---------------------------

Rise time	5 ns ± 1.5 ns
------------------	-------------------

Duration	50 ns -15 ns / +100 ns
-----------------	------------------------

1. For DC, module EXT-IMU D or EXT-IMU P is required!
2. Module EXT-IMU D or EXT-IMU P is required!

Polarity	positive negative alternating
Burst Repetition	1 ms - 1 s
Spike Frequency	1 kHz - 1000 kHz
Burst Duration	0.01 ms - 30 ms
Trigger Mode	automatic manual external
Synchronisation EUT Power	0-359° ±10°
Max. Spikes/s	6990/[Level in kV] ² and max. 8000
Coupling Device	Internal CDN Direct Output
Coupling Path	
calibrated	L / N / PE to GND
selectable	individual combination

22.1.3 CWG

Module EXT-IMU4000 S(4) or EXT-IMU4000 S5 required.

Standard	IEC 61000-4-5
Coupling Device	Internal CDN Direct Output
Coupling Impedance ³	2 Ω/ 18 μF 12 Ω/ 9 μF 12 Ω/ 18 μF
Coupling Path	L1 - N L1 - PE N - PE Impulse Out
Open Circuit	
Level	
EXT-IMU4000 S(4)	250 V - 4.1 kV ±10 %
EXT-IMU4000 S5	250 V - 5.1 kV ±10 %
Rise time	1.2 μs ±30 %
Duration	
Direct Output	50 μs ±20 %
Int. CDN Line - Line	50 μs ±20 %
Int. CDN Line - PE	50 μs +10 μs / -25 μs
Short Circuit 2 Ω/ 18 μF	
Level	
EXT-IMU4000 S(4)	125 A - 2.05 kA ±10 %
EXT-IMU4000 S5	125 A - 2.55 kA ±10 %
Rise time	8 μs ±20 %
Duration	20 μs ±20 %

3. Calibrated coupling Line to Line 2 Ω/ 18 μF and Line to PE 12 Ω/ 9 μF.

Short Circuit 12 Ω/ 9 μF

Level	
EXT-IMU4000 S(4)	20.83 A - 341.7 A ±10 %
EXT-IMU4000 S5	20.83 A - 425 A ±10 %
Rise time	2.5 μs ±30 %
Duration	25 μs ±30 %
Polarity	positive negative alternating
Pulse repetition	
up to 820 V	1 s
at 4.1 kV	5 s
Trigger Mode	automatic manual external
Synchronisation EUT Power	0-359° ±10°

22.1.4

CWG Magnetic Field

Standard	IEC 61000-4-9
Polarity	positive negative alternating
Trigger Mode	automatic manual external
Coupling Device	MF1000-1 MF1000-2
MF1000-1	
Coil Factor	0.9
Level	
EXT-IMU4000 S(4)	93 A/m - 1521 A/m ±10 %
EXT-IMU4000 S5	93 A/m - 1855 A/m ±10 %
Rise Time	8 μs +2.4 μs / -0.8 μs
Duration	20 μs +6 μs / -2 μs
MF1000-2	
Coil Factor	0.66
Level	
EXT-IMU4000 S(4)	67 A/m - 1103 A/m ±10 %
EXT-IMU4000 S5	67 A/m - 1345 A/m ±10 %
Rise Time	8 μs +3.2 μs / -0.8 μs
Duration	20 μs +8 μs / -2 μs
2 x MF1000-1 in parallel	
Coil Factor	0.94
Level	
EXT-IMU4000 S(4)	55 A/m - 898 A/m ±10 %
EXT-IMU4000 S5	55 A/m - 1117 A/m ±10 %

22.1.5 AC Magnetic Field

Standard	IEC 61000-4-8
Coupling Device	MF1000-1 MF1000-2 MF1000-3
MF1000-1	
Coil Factor	0.87
Level	
Range 1	0.8 A/m - 5.0 A/m
Range 2	5.0 A/m - 40 A/m
Range 3	40 A/m - 160 A/m
MF1000-2	
Coil Factor	0.66
Level	
Range 1	0.5 A/m - 3.5 A/m
Range 2	3.5 A/m - 28 A/m
Range 3	28 A/m - 110 A/m
MF1000-3	
Coil Factor	0.87
Level	
with EXT-IMU V	150 A/m - 500 A/m continuous Max. 1100 A/m for up to 3 s
with VAR-EXT1000	150 A/m - 1100 A/m continuous

22.1.6 AC DIP/Interruption

Module EXT-IMU D required

Standard	IEC 61000-4-11
Trigger Mode	automatic manual
Power Source	EXT-IMU V (internal Variac) VAR-EXT1000 (external Variac) SRC16-1P (external tap-transformer) Custom Device
EUT Voltage	
with SRC16-1P and Custom Device	0 - 300 V
with EXT-IMU V	20 - 250 V
with VAR-EXT1000	50 - 250 V
EUT Current	
with SRC16-1P and Custom Device	16 A
with EXT-IMU V	5 A
with VAR-EXT1000	16 A
Inrush Current	>500 A
Switch Time into 100 Ω	1 - 5 μs
Switching Over- / Undershoot	<5 % of Ut
Switching Mode	Pwr2 On High Impedance
DIP Mode ⁴	< 1 Period > 1 Period Option 3.2
DIP Mode <1 Period	
Max. Number of DIPs	2 each period
Start Angle	0 - 359° ±5°
Stop Angle	0 - 359° ±5°
DIP Mode >1 Period	
Start Angle	0 - 359° ±5°
DIP Duration	10 - 60'000 ms ±5 %
DIP Mode Option 3.2	
Start Angle	0° ±5°
DIP Duration	3 x 1 s ±5 %
Pause between Single Dip	50 ms ±5 %
Repetition	2 - 600 s
Test Time	10 - 60'000 s

4. Option 3.2 is a special dip mode for testing electricity meters according to IEC 62052-11.

22.1.7 Voltage Variation

Module EXT-IMU D required

Standard	IEC 61000-4-11
Power Source	EXT-IMU V (internal Variac) VAR-EXT1000 (external Variac)
Variation Mode	Abrupt Adjust
EUT Voltage	
EXT-IMU V	20 - 250 V
VAR-EXT1000	50 - 250 V
EUT Current	
EXT-IMU V	5 A
VAR-EXT1000	16 A
Variation Level	0 - 99 %
Time nominal level	1 - 99 s
Time decreasing	25 - 999 periods
Time low level	1 - 99 periods
Time increasing	25 - 999 periods
Number of cycles	1 - 9999

22.1.8 DC DIP/Interruption

Module EXT-IMU D required

Standard	IEC 61000-4-29
Trigger Mode	automatic manual
Power Source	PS3 (external Power Supply) Custom Device
Nominal Voltage	
selectable	10 - 300 V
calibrated	24 V - 300 V ± 10 %
Test Level ⁵	3 % - 120 % ± 10 %
EUT Current	max. 16 A
Switch Time into 100 Ω	1 - 50 μ s
Switching Over- / Undershoot	<10 % of voltage change
Switching Mode	Pwr2 On High Impedance
Dip Duration	0.1 - 60'000 ms
Repetition	1 - 600 s
Test Time	1 - 60'000 s
Inrush Current	
110 V	>220 A
220 V	>440 A
300 V	>600 A

5. Absolute value between 10 V and 300 V.

22.1.9 Common Mode Disturbance

Module EXT-IMU C required.

Standard	IEC 61000-4-16
Test type	Mains Frequency Custom Sweep
Test Mode	
Mains Frequency Test	Continuous Short
Frequency Test	Fix Sweep
Level ⁶	0.1 V - 35 V \pm 10 %
Frequency	DC 15 Hz - 150 kHz \pm 1 %
Impedance	50 Ω \pm 10 %
sinusoidal THD	<1 %
Mains Frequency Test	
Test Mode	Continuous Short
Short Duration	1 - 10 s \pm 10 %
Short Repetition	2 - 6000 s \pm 10 %
DC ripple	<5 %
DC switching time	1 - 5 μ s
AC Switch On/Off Angle	0° \pm 5°
Trigger Mode	automatic manual
Frequency Test	
Test Mode	Sweep Fix
Decade Time for sweep	10 - 1000 s \pm 10 %

6. For short duration disturbance tests higher than Level 2 (30 V), EXT-IMU C-SHORT is required.

22.1.10

Main System

Input Power	
Voltage	100 V - 240 V \pm 10 %
Frequency	50 Hz - 60 Hz
Current	max. 4 A
Consumption	
Switched off	0 VA
Standby	<15 VA
Test running	max. 150 VA
Dimensions	57 cm x 45 cm x 19 cm / 19" 4HU
Weight	
Mainframe	16 kg
EXT-IMU4000 S	2.6 kg
EXT-IMU4000 Fx	2.1 kg
EXT-IMU V	7 kg
EXT-IMU D	0.7 kg
EXT-IMU C	0.3 kg
Environmental Conditions	
Temperature	10 °C - 35 °C
Humidity	<80 % non condensing
Pressure	86 kPa - 106 kPa
System	
Display	7" Capacitive Touch
Internal memory	1 GB RAM 4 GB Flash
Environmental Measurement	Temperature Humidity
Connections	
USB	2 * Typ A Plug
LAN	RJ45 Gigabit Ethernet
U Peak	BNC max. 15 V
I Peak	BNC max. 15 V
U Power	BNC max. 15 V
I Power	BNC max. 15 V
Trigger Output	BNC max. 6 V
Control Ports	2 x RS485
Auxiliary Connector	Safety Circuit Warning Lamps (24 V / max. 2.4 W)

Multi Purpose Connection	
Rearpanel	2 * BNC
Programmable Inputs	Trigger Input Start Test Stop Test EUT Fail EUT Mark Emergency Stop
Input Low Voltage	< 1.5 V
Input High Voltage	> 2.3 V
Max. Input Voltage	24 V
Programmable Outputs	Running State Safety Circuit State
Max. Output Voltage ⁷	24 V
Max. Output Current	300 mA

22.2

IMU-MGE

22.2.1

EUT Power Management

EUT Power ⁸	
Power input 1	max. 300 V / 16 A fused
Power input 2	max. 300 V / 16 A unfused
Frequency	DC - 60 Hz
Internal Variac	
Input Voltage	20 - 250 V
Frequency	50/60 Hz
Output Voltage at no load	0 - 100% of $V_{in} \pm 5\%$
Continuous Output Current	5 A @100 %
Voltage Slew Rate	<1 s from 0 - 100 %
Power Switch	manual automatic
Measurement	Voltage Current
On / Off Synchronisation ⁹	0 - 359°
EUT overcurrent protection	programmable fuse

7. The output functions as open drain output

8. For DC, module EXT-IMU D or EXT-IMU P is required!

9. Module EXT-IMU D or EXT-IMU P is required!

22.2.2

EFT

Module EXT-IMU3000 F5, EXT-IMU3000 F6 or EXT-IMU3000 F7 required.

Standard	IEC 61000-4-4
Output Impedance	50 Ω
Open circuit Level	
EXT-IMU3000 F5	200 V - 5300 V
EXT-IMU3000 F6	200 V - 6300 V
EXT-IMU3000 F7	200 V - 7100 V
Waveshape into 50 Ω	
Level	
EXT-IMU3000 F5	100 V - 2650 V ± 10 %
EXT-IMU3000 F6	100 V - 3150 V ± 10 %
EXT-IMU3000 F7	100 V - 3550 V ± 10 %
Rise time	
Direct Output	5 ns ± 1.5 ns
Internal CDN	5.5 ns ± 1.5 ns
Duration	50 ns ± 15 ns
Waveshape into 1 kΩ	
Level	
EXT-IMU3000 F5	191 V - 5048 V ± 20 %
EXT-IMU3000 F6	191 V - 6000 V ± 20 %
EXT-IMU3000 F7	191 V - 6762 V ± 20 %
Rise time	5 ns ± 1.5 ns
Duration	50 ns -15 ns / +100 ns
Polarity	positive negative alternating
Burst Repetition	1 ms - 1 s
Spike Frequency	1 kHz - 1000 kHz
Burst Duration	0.01 ms - 30 ms
Trigger Mode	automatic manual external
Synchronisation EUT Power	0-359° ± 10 °
Max. Spikes/s	12815/[Level in kV] ² and max. 8000
Coupling Device	Internal CDN Direct Output
Coupling Path	
calibrated	L / N / PE to GND
selectable	individual combination

22.2.3

CWG

Module EXT-IMU3000 S or EXT-IMU3000 S6 required.

Standard	IEC 61000-4-5
Coupling Device	Internal CDN Direct Output
Coupling Impedance ¹⁰	2 Ω/ 18 μF 12 Ω/ 9 μF 12 Ω/ 18 μF
Coupling Path	L1 - N L1 - PE N - PE Impulse Out
Open Circuit	
Level	
EXT-IMU3000 S	250 V - 8 kV ±10 %
EXT-IMU3000 S6	250 V - 6.6 kV ±10 %
Rise time	1.2 μs ±30 %
Duration	
Direct Output	50 μs ±20 %
Int. CDN Line - Line	50 μs ±20 %
Int. CDN Line - PE	50 μs +10 μs / -25 μs
Short Circuit 2 Ω/ 18 μF	
Level	
EXT-IMU3000 S	125 A - 4 kA ±10 %
EXT-IMU3000 S6	125 A - 3.3 kA ±10 %
Rise time	8 μs ±20 %
Duration	20 μs ±20 %
Short Circuit 12 Ω/ 9 μF	
Level	
EXT-IMU3000 S	20.83 A - 666 A ±10 %
EXT-IMU3000 S6	20.83 A - 550 A ±10 %
Rise time	2.5 μs ±30 %
Duration	25 μs ±30 %
Polarity	positive negative alternating
Pulse repetition	
up to 666 V	1 s
at 8 kV	12 s
Trigger Mode	automatic manual external
Synchronisation EUT Power	0-359° ±10°

10. Calibrated coupling Line to Line 2 Ω/ 18 μF and Line to PE 12 Ω/ 9 μF.

22.2.4 CWG Magnetic Field

Module EXT-IMU3000 S or EXT-IMU3000 S6 required.

Standard	IEC 61000-4-9
Polarity	positive negative alternating
Trigger Mode	automatic manual external
Coupling Device	MF1000-1 MF1000-2
MF1000-1	
Coil Factor	0.9
Level	93 A/m - 1855 A/m $\pm 10\%$
Rise Time	8 μs +2.4 μs / -0.8 μs
Duration	20 μs +6 μs / -2 μs
MF1000-2	
Coil Factor	0.66
Level	93 A/m - 1345 A/m $\pm 10\%$
Rise Time	8 μs +3.2 μs / -0.8 μs
Duration	20 μs +8 μs / -2 μs
2 x MF1000-1 in parallel	
Coil Factor	0.94
Level	55 A/m - 1314 A/m $\pm 10\%$

22.2.5 AC Magnetic Field

Standard	IEC 61000-4-8
Coupling Device	MF1000-1 MF1000-2 MF1000-3
MF1000-1	
Coil Factor	0.87
Level	
Range 1	0.8 A/m - 5.0 A/m
Range 2	5.0 A/m - 40 A/m
Range 3	40 A/m - 160 A/m
MF1000-2	
Coil Factor	0.66
Level	
Range 1	0.5 A/m - 3.5 A/m
Range 2	3.5 A/m - 28 A/m
Range 3	28 A/m - 110 A/m
MF1000-3	
Coil Factor	0.87
Level	
with EXT-IMU V	150 A/m - 500 A/m continuous Max. 1100 A/m for up to 3 s
with VAR-EXT1000	150 A/m - 1100 A/m continuous

22.2.6 Ringwave

Module EXT-IMU3000 R or EXT-IMU3000 R6 required.

Standard	IEC 61000-4-12
Coupling Device	Internal CDN Direct Output
Impedance	12 Ω 30 Ω
Coupling Path	L1 - N L1 - PE N - PE Impulse Out
Open Circuit	
Level	
EXT-IMU3000 R	250 V - 8 kV ± 10 %
EXT-IMU3000 R6	250 V - 6.6 kV ± 10 %
Rise time	0.5 μ s ± 30 %
Frequency	100 kHz ± 10 %
Decay	
Peak 2 to Peak 1	0.4 - 1.1
Peak 3 to Peak 2	0.4 - 0.8
Peak 4 to Peak 3	0.4 - 0.8
Short Circuit	
Level 12 Ω	
EXT-IMU3000 R	20.8 A - 666.6 A ± 10 %
EXT-IMU3000 R6	20.8 A - 550 A ± 10 %
Level 30 Ω	
EXT-IMU3000 R	8.3 A - 266.6 A ± 10 %
EXT-IMU3000 R6	8.3 A - 220 A ± 10 %
Rise time	0.2 μ s - 1 μ s
Duration	20 μ s ± 20 %
Polarity	positive negative alternating
Pulse repetition	1 s - 600 s
Trigger Mode	automatic manual external
Synchronisation EUT Power	0-359° ± 10 °

22.2.7

Telecom

Module EXT-IMU3000 T or EXT-IMU3000 T6 required.

Standard	IEC 61000-4-5
Impedance	15 Ω
	40 Ω
Open Circuit	
Level	
EXT-IMU3000 T	250 V - 8 kV ± 10 %
EXT-IMU3000 T6	250 V - 6.6 kV ± 10 %
Rise time	10 μ s ± 30 %
Duration	700 μ s ± 20 %
Short Circuit 40 Ω	
Level	
EXT-IMU3000 T	6.25 A - 200 A ± 10 %
EXT-IMU3000 T6	6.25 A - 165 A ± 10 %
Rise time	5 μ s ± 20 %
Duration	320 μ s ± 20 %
Polarity	positive negative alternating
Pulse repetition	
up to 333V	1 s
at 8kV	24 s
Trigger Mode	automatic manual external
Coupling Device	Direct Output

22.2.8 AC DIP/Interruption

Module EXT-IMU D required

Standard	IEC 61000-4-11
Trigger Mode	automatic manual
Power Source	EXT-IMU V (internal Variac) VAR-EXT1000 (external Variac) SRC16-1P (external tap-transformer) Custom Device
EUT Voltage	
with SRC16-1P and Custom Device	0 - 300 V
with EXT-IMU V	20 - 250 V
with VAR-EXT1000	50 - 250 V
EUT Current	
with SRC16-1P and Custom Device	16 A
with EXT-IMU V	5 A
with VAR-EXT1000	16 A
Inrush Current	>500 A
Switch Time into 100 Ω	1 - 5 μs
Switching Over- / Undershoot	<5 % of U_t
Switching Mode	Pwr2 On High Impedance
DIP Mode ¹¹	< 1 Period > 1 Period Option 3.2
DIP Mode <1 Period	
Max. Number of DIPS	2 each period
Start Angle	0 - 359° ±5°
Stop Angle	0 - 359° ±5°
DIP Mode >1 Period	
Start Angle	0 - 359° ±5°
DIP Duration	10 - 60'000 ms ±5 %
DIP Mode Option 3.2	
Start Angle	0° ±5°
DIP Duration	3 x 1 s ±5 %
Pause between Single Dip	50 ms ±5 %
Repetition	2 - 600 s
Test Time	10 - 60'000 s

11. Option 3.2 is a special dip mode for testing electricity meters according to IEC 62052-11.

22.2.9 Voltage Variation

Module EXT-IMU D required

Standard	IEC 61000-4-11
Power Source	EXT-IMU V (internal Variac) VAR-EXT1000 (external Variac)
Variation Mode	Abrupt Adjust
EUT Voltage	
EXT-IMU V	20 - 250 V
VAR-EXT1000	50 - 250 V
EUT Current	
EXT-IMU V	5 A
VAR-EXT1000	16 A
Variation Level	0 - 99 %
Time nominal level	1 - 99 s
Time decreasing	25 - 999 periods
Time low level	1 - 99 periods
Time increasing	25 - 999 periods
Number of cycles	1 - 9999

22.2.10 DC DIP/Interruption

Module EXT-IMU D required

Standard	IEC 61000-4-29
Trigger Mode	automatic manual
Power Source	PS3 (external Power Supply) Custom Device
Nominal Voltage	
selectable	10 - 300 V
calibrated	24 V - 300 V ± 10 %
Test Level ¹²	3 % - 120 % ± 10 %
EUT Current	max. 16 A
Switch Time into 100 Ω	1 - 50 μ s
Switching Over- / Undershoot	<10 % of voltage change
Switching Mode	Pwr2 On High Impedance
Dip Duration	0.1 - 60'000 ms
Repetition	1 - 600 s
Test Time	1 - 60'000 s
Inrush Current	
110 V	>220 A
220 V	>440 A
300 V	>600 A

12. Absolute value between 10 V and 300 V.

22.2.11 Common Mode Disturbance

Module EXT-IMU C required.

Standard	IEC 61000-4-16
Test type	Mains Frequency Custom Sweep
Test Mode	
Mains Frequency Test	Continuous Short
Frequency Test	Fix Sweep
Level ¹³	0.1 V - 35 V ± 10 %
Frequency	DC 15 Hz - 150 kHz ± 1 %
Impedance	50 $\Omega \pm 10$ %
sinusoidal THD	<1 %
Mains Frequency Test	
Test Mode	Continuous Short
Short Duration	1 - 10 s ± 10 %
Short Repetition	2 - 6000 s ± 10 %
DC ripple	<5 %
DC switching time	1 - 5 μ s
AC Switch On/Off Angle	0° ± 5 °
Trigger Mode	automatic manual
Frequency Test	
Test Mode	Sweep Fix
Decade Time for sweep	10 - 1000 s ± 10 %

13. For short duration disturbance tests higher than Level 2 (30 V), EXT-IMU C-SHORT is required.

22.2.12

Main System

Input Power	
Voltage	100 V - 240 V \pm 10 %
Frequency	50 Hz - 60 Hz
Current	max. 4 A
Consumption	
Switched off	0 VA
Standby	<15 VA
Test running	max. 150 VA
Dimensions	60 cm x 45 cm x 37 cm / 19" 8HU
Weight	
Mainframe	30 kg
EXT-IMU3000 S	4.7 kg
EXT-IMU3000 R	2 kg
EXT-IMU3000 T	2.2 kg
EXT-IMU3000 Fx	1.8 kg
EXT-IMU V	7 kg
EXT-IMU D	0.7 kg
EXT-IMU C	0.3 kg
Environmental Conditions	
Temperature	10 °C - 35 °C
Humidity	<80 % non condensing
Pressure	86 kPa - 106 kPa
System	
Display	7" Capacitive Touch
Internal memory	1 GB RAM 4 GB Flash
Environmental Measurement	Temperature Humidity
Connections	
USB	2 * Typ A Plug
LAN	RJ45 Gigabit Ethernet
U Peak	BNC max. 15 V
I Peak	BNC max. 15 V
U Power	BNC max. 15 V
I Power	BNC max. 15 V
Trigger Output	BNC max. 6 V
Control Ports	2 x RS485
Auxiliary Connector	Safety Circuit Warning Lamps (24 V / max. 2.4 W)

Multi Purpose Connection	
Rearpanel	2 * BNC
Programmable Inputs	Trigger Input Start Test Stop Test EUT Fail EUT Mark Emergency Stop
Input Low Voltage	< 1.5 V
Input High Voltage	> 2.3 V
Max. Input Voltage	24 V
Programmable Outputs	Running State Safety Circuit State
Max. Output Voltage ¹⁴	24 V
Max. Output Current	300 mA

22.3

CDN-M-x-32

22.3.1

EUT

AC	
Lines	L1 / L2 / L3 / N / PE
Voltage ¹⁵	
Line to Line	max. 690 V
Line to Neutral	max. 400 V
Line to Ground	max. 400 V
Current	3 x 32 A
Frequency	50 Hz / 60 Hz
DC	
Lines	String1+ / String1- String2+ / String2-
Voltage ¹⁶	
Basic Version	max. 500 V
OPT-A-x-32 1000V DC	max. 1000 V
Current	max. 32 A

14. The output functions as open drain output

15. The maximum ac-voltage is limited due to the hardware of the generator. IMU4000 with an older surge module (EXT-TRA3000 S and EXT-IMU4000 S with hardware version 1) limits the maximum voltage to 480V (Line-Line) and 300V (Line-PE). For EXT-IMU4000 S4, EXT-IMU4000 S5, IMU3000, IMU-MGS and IMU-MGE, there is no additional limitation.

16. The maximum dc-voltage is limited due to the hardware of the generator. The surge module of IMU4000 (EXT-TRA3000 S, EXT-IMU4000 S) with hardware version 1 limits the maximum voltage for DC+ and DC- to 300Vdc against ground. For EXT-IMU4000 S4, EXT-IMU4000 S5 and IMU-MGS, there is no additional limitation. The measurement module of IMU3000 (Measurement) with hardware version 1 limits the maximum voltage for DC+ and DC- to 300Vdc against ground. Hardware version 2 allow a maximum dc-voltage of 1000V. The hardware version can be found in the General Menu > Generator > Extension. There is no additional limitation for IMU-MGE.

22.3.2

EFT

Standard	IEC 61000-4-4
Coupling	
AC	
calibrated	L1 / L2 / L3 / N / PE to Ground
selectable	individual combination
DC	
calibrated	String1+ / String1- / PE to Ground String2+ / String2- / PE to Ground
selectable	individual combination
Voltage into 50 Ohm	
Level calibrated	
CDN-M-6-32	500 V - 6 kV $\pm 10\%$
CDN-M-8-32	500 V - 7.1 kV $\pm 10\%$
Front Time	5.5 ns ± 1.5 ns
Duration	45 ns ± 15 ns
Residual Voltage	<5 % of applied test voltage

22.3.3

CWG

Standard	IEC 61000-4-5
Coupling	
AC	
Line to Line	L1-L2 L1-L3 L2-L3 Lx-N
Line to Ground	Lx-PE N-PE
DC	
Line to Line	String1+ - String1- String2+ - String2-
Line to Ground	String1+ - PE String1- - PE String2+ - PE String2- - PE
Impedance ¹⁷	2 Ω/ 18 μF 12 Ω/ 9 μF 12 Ω/ 18 μF 2 Ω/ 9 μF
Open Circuit Voltage	
Level Line to Line	
CDN-M-6-32	250 V - 6 kV ±10 %
CDN-M-8-32	250 V - 7.6 kV ±10 %
Level Line to Ground	
CDN-M-6-32	250 V - 6 kV ±10 %
CDN-M-8-32	250 V - 8 kV ±10 %
Front Time	1.2 μs ±30 %
Duration	
Line to Line	50 μs +10 μs/-10 μs
Line to Ground	50 μs +10 μs/-25 μs
Residual Voltage	<12 % of applied test voltage
Level non-surged lines	<12 % of applied test voltage

17. The impedance is freely selectable for all couplings. The calibration is performed according IEC 61000-4-5 with 2Ω/18μF for Line-Line and 12Ω/9μF for Line-PE.

Short Circuit Current

Level Line to Line

CDN-M-6-32	125 A - 3 kA ± 10 %
CDN-M-8-32	125 A - 3.8 kA ± 10 %

Level Line to Ground

CDN-M-6-32	20.83 A - 500 A ± 10 %
CDN-M-8-32	20.83 A - 667 A ± 10 %

Front Time

Line to line	8 μ s ± 20 %
Line to Ground	2.5 μ s ± 30 %

Duration

Line to line	20 μ s ± 20 %
Line to Ground	25 μ s ± 30 %

Synchronisation

on EUT-Power

Generator

IMU-MGE / IMU3000
IMU-MGS / IMU4000

22.3.4

Ringwave

For ringwave, the additional option OPT-A-x-32 RWG is required.

Standard	IEC 61000-4-12
Coupling	
AC	
Line to Line	L1-L2 L1-L3 L2-L3 LX-N
Line to Ground	LX-PE N-PE
DC	
Line to Line	String1+ - String1- String2+ - String2-
Line to Ground	String1+ - PE String1- - PE String2+ - PE String2- - PE
Impedance	12 Ω 30 Ω
Open Circuit Voltage	
Level 12 Ω	
CDN-M-6-32	250 V - 6 kV ±10 %
CDN-M-8-32	250 V - 7.6 kV ±10 %
Level 30 Ω	
CDN-M-6-32	250 V - 6 kV ±10 %
CDN-M-8-32	250 V - 8 kV ±10 %
Front Time	500 ns ±30 %
Voltage frequency	100 kHz ±10 %
Peak ratio	
Peak2 to Peak1	0.4 to 1.1
Peak3 to Peak2	0.4 to 0.8
Peak4 to Peak3	0.4 to 0.8
Residual Voltage	<12 % of applied test voltage
Level non-surged lines	<12 % of applied test voltage
Short Circuit	
Level 12 Ω	
CDN-M-6-32	20.83 A - 500 A ±10 %
CDN-M-8-32	8.33 A - 633.3 A ±10 %
Level 30 Ω	
CDN-M-6-32	8.33 A - 200 A ±10 %
CDN-M-8-32	8.33 A - 266.7 A ±10 %
Front Time	<1 μs
Synchronisation	on EUT-Power
Generator	IMU-MGE / IMU3000

22.3.5 General

Dimensions	
Basic Version	57 cm x 45 cm x 19 cm / 19" 4HU
Weight	34.4 kg
Environmental Conditions	
Temperature	10 °C - 35 °C
Humidity	<80 % non condensing
Pressure	86 kPa - 106 kPa
Generator	IMU-MGE / IMU3000 IMU-MGS / IMU4000

22.4 CDN-A-x-32

22.4.1 EUT

AC	
Lines	L1 / L2 / L3 / N / PE
Voltage ¹⁸	
Line to Line	max. 690 V
Line to Neutral	max. 400 V
Line to Ground	max. 400 V
Current	3 x 32 A
Frequency	50 Hz / 60 Hz
DC	
Lines	String1+ / String1- String2+ / String2-
Voltage ¹⁹	
Basic Version	max. 500 V
OPT-A-x-32 1000V DC	max. 1000 V
OPT-A-x-32 1500V DC	max. 1500 V
Current	max. 32 A

18. The maximum ac-voltage is limited due to the hardware of the generator. IMU4000 with an older surge module (EXT-TRA3000 S and EXT-IMU4000 S with hardware version 1) limits the maximum voltage to 480V (Line-Line) and 300V (Line-PE). For EXT-IMU4000 S4, EXT-IMU4000 S5, IMU3000, IMU-MGS and IMU-MGE, there is no additional limitation.

19. The maximum dc-voltage is limited due to the hardware of the generator. The surge module of IMU4000 (EXT-TRA3000 S, EXT-IMU4000 S) with hardware version 1 limits the maximum voltage for DC+ and DC- to 300Vdc against ground. For EXT-IMU4000 S4, EXT-IMU4000 S5 and IMU-MGS, there is no additional limitation. The measurement module of IMU3000 (Measurement) with hardware version 1 limits the maximum voltage for DC+ and DC- to 300Vdc against ground. Hardware version 2 allow a maximum dc-voltage of 1000V. For 1500V hardware version ≥ 3 is required. The hardware version can be found in the General Menu > Generator > Extension. There is no additional limitation for IMU-MGE.

22.4.2

EFT

Standard	IEC 61000-4-4
Coupling	
AC	
calibrated	L1 / L2 / L3 / N / PE to Ground
selectable	individual combination
DC	
calibrated	String1+ / String1- / PE to Ground String2+ / String2- / PE to Ground
selectable	individual combination
Voltage into 50 Ohm	
Level calibrated	
CDN-A-6-32	500 V - 6 kV $\pm 10\%$
CDN-A-8-32	500 V - 7.1 kV $\pm 10\%$
Front Time	5.5 ns ± 1.5 ns
Duration	45 ns ± 15 ns
Residual Voltage	<5 % of applied test voltage

22.4.3

CWG

Standard	IEC 61000-4-5 ANSI C62.45
Coupling	
AC	
Line to Line	L1-L2 L1-L3 L2-L3 LX-N
Line to Ground	LX-PE N-PE
with OPT-A-x-32 ANSI	L1&L2&L3&N-PE L1&L2&L3-PE L1&L2&L3-N
DC	
Line to Line	String1+ - String1- String2+ - String2-
Line to Ground	String1+ - PE String1- - PE String2+ - PE String2- - PE
Impedance ²⁰	2 Ω / 18 μ F 12 Ω / 9 μ F 12 Ω / 18 μ F 2 Ω / 9 μ F

20. The impedance is freely selectable for all couplings. The calibration is performed according IEC 61000-4-5 with 2 Ω /18 μ F for Line-Line and 12 Ω /9 μ F for Line-PE.

Open Circuit Voltage

Level Line to Line

CDN-A-6-32	250 V - 6 kV ± 10 %
CDN-A-8-32	250 V - 7.6 kV ± 10 %

Level Line to Ground

CDN-A-6-32	250 V - 6 kV ± 10 %
CDN-A-8-32	250 V - 8 kV ± 10 %

Front Time 1.2 μ s ± 30 %

Duration

Line to Line	50 μ s +10 μ s/-10 μ s
Line to Ground	50 μ s +10 μ s/-25 μ s

Residual Voltage <12 % of applied test voltage

Level non-surged lines <12 % of applied test voltage

Short Circuit Current

Level Line to Line

CDN-A-6-32	125 A - 3 kA ± 10 %
CDN-A-8-32	125 A - 3.8 kA ± 10 %

Level Line to Ground

CDN-A-6-32	20.83 A - 500 A ± 10 %
CDN-A-8-32	20.83 A - 667 A ± 10 %

Front Time

Line to line	8 μ s ± 20 %
Line to Ground	2.5 μ s ± 30 %

Duration

Line to line	20 μ s ± 20 %
Line to Ground	25 μ s ± 30 %

Synchronisation

on EUT-Power

Generator

IMU-MGE / IMU3000
IMU-MGS / IMU4000

22.4.4

Ringwave

For ringwave, the additional option OPT-A-x-32 RWG is required.

Standard	IEC 61000-4-12 ANSI C62.45
Coupling	
AC	
Line to Line	L1-L2 L1-L3 L2-L3 LX-N
Line to Ground	Lx-PE N-PE
with OPT-A-x-32 ANSI	L1&L2&L3&N-PE L1&L2&L3-PE L1&L2&L3-N
DC	
Line to Line	String1+ - String1- String2+ - String2-
Line to Ground	String1+ - PE String1- - PE String2+ - PE String2- - PE
Impedance	12 Ω 30 Ω
Open Circuit Voltage	
Level 12 Ω	
CDN-A-6-32	250 V - 6 kV ±10 %
CDN-A-8-32	250 V - 7.6 kV ±10 %
Level 30 Ω	
CDN-A-6-32	250 V - 6 kV ±10 %
CDN-A-8-32	250 V - 8 kV ±10 %
Front Time	500 ns ±30 %
Voltage frequency	100 kHz ±10 %
Peak ratio	
Peak2 to Peak1	0.4 to 1.1
Peak3 to Peak2	0.4 to 0.8
Peak4 to Peak3	0.4 to 0.8
Residual Voltage	<12 % of applied test voltage
Level non-surged lines	<12 % of applied test voltage
Short Circuit	
Level 12 Ω	
CDN-A-6-32	20.83 A - 500 A ±10 %
CDN-A-8-32	8.33 A - 633.3 A ±10 %
Level 30 Ω	
CDN-A-6-32	8.33 A - 200 A ±10 %
CDN-A-8-32	8.33 A - 266.7 A ±10 %
Front Time	<1 μs

Synchronisation	on EUT-Power
Generator	IMU-MGE / IMU3000

22.4.5 General

Input Power	
Voltage	100 V - 240 V \pm 10 %
Frequency	50 Hz - 60 Hz
Consumption	max. 150 VA
Dimensions	
Basic Version	57 cm x 45 cm x 19 cm / 19" 4HU
with OPT-A-x-32 ANSI	60 cm x 45 cm x 37 cm / 19" 8HU
Weight	
Basic Version	38.8 kg
with OPT-A-x-32 ANSI	tbd kg
Environmental Conditions	
Temperature	10 °C - 35 °C
Humidity	<80 % non condensing
Pressure	86 kPa - 106 kPa
Generator	IMU-MGE / IMU3000 IMU-MGS / IMU4000

22.5 CDN-A-x-63

22.5.1

EUT

AC	
Lines	L1 / L2 / L3 / N / PE
Voltage ²¹	
Line to Line	max. 690 V
Line to Neutral	max. 400 V
Line to Ground	max. 400 V
Current	3 x 63 A
Frequency	50 Hz / 60 Hz
DC	
Lines	String1+ / String1- String2+ / String2-
Voltage ²²	
Basic Version	max. 500 V
OPT-A-x-63 1000V DC	max. 1000 V
OPT-A-x-63 1500V DC	max. 1500 V
Current	max. 63 A

21. The maximum ac-voltage is limited due to the hardware of the generator. IMU4000 with an older surge module (EXT-TRA3000 S and EXT-IMU4000 S with hardware version 1) limits the maximum voltage to 480V (Line-Line) and 300V (Line-PE). For EXT-IMU4000 S4, EXT-IMU4000 S5, IMU3000, IMU-MGS and IMU-MGE, there is no additional limitation.

22. The maximum dc-voltage is limited due to the hardware of the generator. The surge module of IMU4000 (EXT-TRA3000 S, EXT-IMU4000 S) with hardware version 1 limits the maximum voltage for DC+ and DC- to 300Vdc against ground. For EXT-IMU4000 S4, EXT-IMU4000 S5 and IMU-MGS, there is no additional limitation. The measurement module of IMU3000 (Measurement) with hardware version 1 limits the maximum voltage for DC+ and DC- to 300Vdc against ground. Hardware version 2 allow a maximum dc-voltage of 1000V. For 1500V hardware version ≥ 3 is required. The hardware version can be found in the General Menu > Generator > Extension. There is no additional limitation for IMU-MGE.

22.5.2

EFT

Standard	IEC 61000-4-4
Coupling	
AC	
calibrated	L1 / L2 / L3 / N / PE to Ground
selectable	individual combination
DC	
calibrated	String1+ / String1- / PE to Ground String2+ / String2- / PE to Ground
selectable	individual combination
Voltage into 50 Ohm	
Level calibrated	
CDN-A-6-63	500 V - 6 kV $\pm 10\%$
CDN-A-8-63	500 V - 7.1 kV $\pm 10\%$
Front Time	5.5 ns ± 1.5 ns
Duration	45 ns ± 15 ns
Residual Voltage	<5 % of applied test voltage

22.5.3 CWG

For CDNs with option OPT-A-x-63 FULL RANGE, the technical data of CDN-A-x-32 (when selected 32A range) are applicable.

Standard	IEC 61000-4-5 ANSI C62.45
Coupling	
AC	
Line to Line	L1-L2 L1-L3 L2-L3 Lx-N
Line to Ground	Lx-PE N-PE
with OPT-A-x-63 ANSI	L1&L2&L3&N-PE L1&L2&L3-PE L1&L2&L3-N
DC	
Line to Line	String1+ - String1- String2+ - String2-
Line to Ground	String1+ - PE String1- - PE String2+ - PE String2- - PE
Impedance ²³	2 Ω/ 18 μF 12 Ω/ 9 μF 12 Ω/ 18 μF 2 Ω/ 9 μF
Open Circuit Voltage	
Level Line to Line	
CDN-A-6-63	250 V - 6 kV ±10 %
CDN-A-8-63	250 V - 7.6 kV ±10 %
Level Line to Ground	
CDN-A-6-63	250 V - 6 kV +10 % / -15 %
CDN-A-8-63	250 V - 8 kV +10 % / -15 %
Front Time	1.2 μs ±30 %
Duration	
Line to Line	50 μs +10 μs/-20 μs
Line to Ground	50 μs +10 μs/-35 μs
Residual Voltage	<12 % of applied test voltage
Level non-surged lines	<12 % of applied test voltage

²³. The impedance is freely selectable for all couplings. The calibration is performed according IEC 61000-4-5 with 2Ω/18μF for Line-Line and 12Ω/9μF for Line-PE.

Short Circuit Current

Level Line to Line	
CDN-A-6-63	125 A - 3 kA ± 10 %
CDN-A-8-63	125 A - 3.8 kA ± 10 %
Level Line to Ground	
CDN-A-6-63	20.83 A - 500 A ± 10 %
CDN-A-8-63	20.83 A - 667 A ± 10 %
Front Time	
Line to line	8 μ s ± 20 %
Line to Ground	2.5 μ s ± 30 %
Duration	
Line to line	20 μ s ± 20 %
Line to Ground	25 μ s ± 30 %
Synchronisation	on EUT-Power
Generator	IMU-MGE / IMU3000 IMU-MGS / IMU4000

22.5.4 Ringwave

For ringwave, the additional option OPT-A-x-63 RWG is required. For CDNs with option OPT-A-x-63 FULL RANGE, the technical data of CDN-A-x-32 (when selected 32A range) are applicable.

Standard	IEC 61000-4-12 ANSI C62.45
Coupling	
AC	
Line to Line	L1-L2 L1-L3 L2-L3 Lx-N
Line to Ground	Lx-PE N-PE
with OPT-A-x-63 ANSI	L1&L2&L3&N-PE L1&L2&L3-PE L1&L2&L3-N
DC	
Line to Line	String1+ - String1- String2+ - String2-
Line to Ground	String1+ - PE String1- - PE String2+ - PE String2- - PE
Impedance	12 Ω 30 Ω
Open Circuit Voltage	
Level 12 Ω	
CDN-A-6-63	250 V - 6 kV ±10 %
CDN-A-8-63	250 V - 8 kV ±10 %
Level 30 Ω	
CDN-A-6-63	250 V - 6 kV ±10 %
CDN-A-8-63	250 V - 8 kV ±10 %
Front Time	500 ns ±30 %
Voltage frequency	100 kHz ±10 %
Peak ratio	
Peak2 to Peak1	0.4 to 1.1
Peak3 to Peak2	0.4 to 0.8
Peak4 to Peak3	0.4 to 0.8
Residual Voltage	<12 % of applied test voltage
Level non-surged lines	<12 % of applied test voltage

Short Circuit

Level 12 Ω	
CDN-A-6-63	20.83 A - 500 A +10 % / -25 %
CDN-A-8-63	8.33 A - 666.7 A +10 % / -25 %
Level 30 Ω	
CDN-A-6-63	8.33 A - 200 A +10 % / -25 %
CDN-A-8-63	8.33 A - 266.7 A +10 % / -25 %
Front Time	<1 μs
Synchronisation	on EUT-Power
Generator	IMU-MGE / IMU3000

22.5.5

General

Input Power	
Voltage	100 V - 240 V ±10 %
Frequency	50 Hz - 60 Hz
Consumption	max. 150 VA
Dimensions	60 cm x 45 cm x 37 cm / 19" 8HU
Weight	71 kg
Environmental Conditions	
Temperature	10 °C - 35 °C
Humidity	<80 % non condensing
Pressure	86 kPa - 106 kPa
Generator	IMU-MGE / IMU3000 IMU-MGS / IMU4000

22.6

CDN-A-x-125

22.6.1

EUT

AC	
Lines	L1 / L2 / L3 / N / PE
Voltage ²⁴	
Line to Line	max. 690 V
Line to Neutral	max. 400 V
Line to Ground	max. 400 V
Current	3 x 125 A
Frequency	50 Hz / 60 Hz
DC	
Lines	String1+ / String1- String2+ / String2-
Voltage ²⁵	
Basic Version	max. 500 V
OPT-A-x-125 1000V DC	max. 1000 V
OPT-A-x-125 1500V DC	max. 1500 V
Current	max. 125 A

24. The maximum ac-voltage is limited due to the hardware of the generator. IMU4000 with an older surge module (EXT-TRA3000 S and EXT-IMU4000 S with hardware version 1) limits the maximum voltage to 480V (Line-Line) and 300V (Line-PE). For EXT-IMU4000 S4, EXT-IMU4000 S5, IMU3000, IMU-MGS and IMU-MGE, there is no additional limitation.

25. The maximum dc-voltage is limited due to the hardware of the generator. The surge module of IMU4000 (EXT-TRA3000 S, EXT-IMU4000 S) with hardware version 1 limits the maximum voltage for DC+ and DC- to 300Vdc against ground. For EXT-IMU4000 S4, EXT-IMU4000 S5 and IMU-MGS, there is no additional limitation. The measurement module of IMU3000 (Measurement) with hardware version 1 limits the maximum voltage for DC+ and DC- to 300Vdc against ground. Hardware version 2 allow a maximum dc-voltage of 1000V. For 1500V hardware version ≥ 3 is required. The hardware version can be found in the General Menu > Generator > Extension. There is no additional limitation for IMU-MGE.

22.6.2

EFT

Standard	IEC 61000-4-4
Coupling	
AC	
calibrated	L1 / L2 / L3 / N / PE to Ground
selectable	individual combination
DC	
calibrated	String1+ / String1- / PE to Ground String2+ / String2- / PE to Ground
selectable	individual combination
Voltage into 50 Ohm	
Level calibrated	
CDN-A-6-125	500 V - 6 kV ± 10 %
CDN-A-8-125	500 V - 7.1 kV ± 10 %
Front Time	5.5 ns ± 1.5 ns
Duration	45 ns ± 15 ns
Residual Voltage	<5 % of applied test voltage

22.6.3

CWG

For CDNs with option OPT-A-x-125 FULL RANGE, the technical data of CDN-A-x-63 (when selected 63A range) or CDN-A-x-32 (when selected 32A range) are applicable.

Standard	IEC 61000-4-5 ANSI C62.45
Coupling	
AC	
Line to Line	L1-L2 L1-L3 L2-L3 Lx-N
Line to Ground	Lx-PE N-PE
with OPT-A-x-125 ANSI	L1&L2&L3&N-PE L1&L2&L3-PE L1&L2&L3-N
DC	
Line to Line	String1+ - String1- String2+ - String2-
Line to Ground	String1+ - PE String1- - PE String2+ - PE String2- - PE
Impedance ²⁶	2 Ω/ 18 μF 12 Ω/ 9 μF 12 Ω/ 18 μF 2 Ω/ 9 μF
Open Circuit Voltage	
Level Line to Line	
CDN-A-6-125	250 V - 6 kV ±10 %
CDN-A-8-125	250 V - 7.6 kV ±10 %
Level Line to Ground	
CDN-A-6-125	250 V - 6 kV +10 % / -20 %
CDN-A-8-125	250 V - 8 kV +10 % / -20 %
Front Time	1.2 μs ±30 %
Duration	
Line to Line	50 μs +10 μs/-25 μs
Line to Ground	50 μs +10 μs/-40 μs
Residual Voltage	<12 % of applied test voltage
Level non-surged lines	<12 % of applied test voltage

²⁶. The impedance is freely selectable for all couplings. The calibration is performed according IEC 61000-4-5 with 2Ω/18μF for Line-Line and 12Ω/9μF for Line-PE.

Short Circuit Current

Level Line to Line	
CDN-A-6-125	125 A - 3 kA ± 10 %
CDN-A-8-125	125 A - 3.8 kA ± 10 %
Level Line to Ground	
CDN-A-6-125	20.83 A - 500 A ± 10 %
CDN-A-8-125	20.83 A - 667 A ± 10 %
Front Time	
Line to line	8 μ s ± 20 %
Line to Ground	2.5 μ s ± 30 %
Duration	
Line to line	20 μ s ± 20 %
Line to Ground	25 μ s ± 30 %
Synchronisation	on EUT-Power
Generator	IMU-MGE / IMU3000 IMU-MGS / IMU4000

22.6.4 Ringwave

For ringwave, the additional option OPT-A-x-125 RWG is required. For CDNs with option OPT-A-x-125 FULL RANGE, the technical data of CDN-A-x-63 (when selected 63A range) or CDN-A-x-32 (when selected 32A range) are applicable.

Standard	IEC 61000-4-12 ANSI C62.45
Coupling	
AC	
Line to Line	L1-L2 L1-L3 L2-L3 Lx-N
Line to Ground	Lx-PE N-PE
with OPT-A-x-125 ANSI	L1&L2&L3&N-PE L1&L2&L3-PE L1&L2&L3-N
DC	
Line to Line	String1+ - String1- String2+ - String2-
Line to Ground	String1+ - PE String1- - PE String2+ - PE String2- - PE
Impedance	12 Ω 30 Ω
Open Circuit Voltage	
Level 12 Ω	
CDN-A-6-125	250 V - 6 kV ±10 %
CDN-A-8-125	250 V - 8 kV ±10 %
Level 30 Ω	
CDN-A-6-125	250 V - 6 kV ±10 %
CDN-A-8-125	250 V - 8 kV ±10 %
Front Time	500 ns ±30 %
Voltage frequency	100 kHz ±10 %
Peak ratio	
Peak2 to Peak1	0.4 to 1.1
Peak3 to Peak2	0.4 to 0.8
Peak4 to Peak3	0.4 to 0.8
Residual Voltage	<12 % of applied test voltage
Level non-surged lines	<12 % of applied test voltage

Short Circuit

Level 12 Ω	
CDN-A-6-125	20.83 A - 500 A +10 % / -25 %
CDN-A-8-125	8.33 A - 666.7 A +10 % / -25 %
Level 30 Ω	
CDN-A-6-125	8.33 A - 200 A +10 % / -25 %
CDN-A-8-125	8.33 A - 266.7 A +10 % / -25 %
Front Time	<1 μs
Synchronisation	on EUT-Power
Generator	IMU-MGE / IMU3000

22.6.5

General

Input Power	
Voltage	100 V - 240 V ±10 %
Frequency	50 Hz - 60 Hz
Consumption	max. 150 VA
Dimensions	60 cm x 65 cm x 105 cm
Weight	191 kg
Environmental Conditions	
Temperature	10 °C - 35 °C
Humidity	<80 % non condensing
Pressure	86 kPa - 106 kPa
Generator	IMU-MGE / IMU3000 IMU-MGS / IMU4000

22.7

CDN-A-x-200

22.7.1

EUT

AC	
Lines	L1 / L2 / L3 / N / PE
Voltage ²⁷	
Line to Line	max. 690 V
Line to Neutral	max. 400 V
Line to Ground	max. 400 V
Current	3 x 200 A
Frequency	50 Hz / 60 Hz
DC	
Lines	String1+ / String1- String2+ / String2-
Voltage ²⁸	
Basic Version	max. 500 V
OPT-A-x-200 1000V DC	max. 1000 V
OPT-A-x-200 1500V DC	max. 1500 V
Current	max. 200 A

27. The maximum ac-voltage is limited due to the hardware of the generator. IMU4000 with an older surge module (EXT-TRA3000 S and EXT-IMU4000 S with hardware version 1) limits the maximum voltage to 480V (Line-Line) and 300V (Line-PE). For EXT-IMU4000 S4, EXT-IMU4000 S5, IMU3000, IMU-MGS and IMU-MGE, there is no additional limitation.

28. The maximum dc-voltage is limited due to the hardware of the generator. The surge module of IMU4000 (EXT-TRA3000 S, EXT-IMU4000 S) with hardware version 1 limits the maximum voltage for DC+ and DC- to 300Vdc against ground. For EXT-IMU4000 S4, EXT-IMU4000 S5 and IMU-MGS, there is no additional limitation. The measurement module of IMU3000 (Measurement) with hardware version 1 limits the maximum voltage for DC+ and DC- to 300Vdc against ground. Hardware version 2 allow a maximum dc-voltage of 1000V. For 1500V hardware version ≥ 3 is required. The hardware version can be found in the General Menu > Generator > Extension. There is no additional limitation for IMU-MGE.

22.7.2

EFT

Standard	IEC 61000-4-4
Coupling	
AC	
calibrated	L1 / L2 / L3 / N / PE to Ground
selectable	individual combination
DC	
calibrated	String1+ / String1- / PE to Ground String2+ / String2- / PE to Ground
selectable	individual combination
Voltage into 50 Ohm	
Level calibrated	
CDN-A-6-200	500 V - 6 kV $\pm 10\%$
CDN-A-8-200	500 V - 7.1 kV $\pm 10\%$
Front Time	5.5 ns ± 1.5 ns
Duration	45 ns ± 15 ns
Residual Voltage	<5 % of applied test voltage

22.7.3 CWG

For CDNs with option OPT-A-x-200 FULL RANGE, the technical data of CDN-A-x-125 (when selected 125A range), CDN-A-x-63 (when selected 63A range) or CDN-A-x-32 (when selected 32A range) are applicable.

Standard	IEC 61000-4-5 ANSI C62.45
Coupling	
AC	
Line to Line	L1-L2 L1-L3 L2-L3 Lx-N
Line to Ground	Lx-PE N-PE
with OPT-A-x-200 ANSI	L1&L2&L3&N-PE L1&L2&L3-PE L1&L2&L3-N
DC	
Line to Line	String1+ - String1- String2+ - String2-
Line to Ground	String1+ - PE String1- - PE String2+ - PE String2- - PE
Impedance ²⁹	2 Ω/ 18 μF 12 Ω/ 9 μF 12 Ω/ 18 μF 2 Ω/ 9 μF
Open Circuit Voltage	
Level Line to Line	
CDN-A-6-200	250 V - 6 kV ±10 %
CDN-A-8-200	250 V - 7.6 kV ±10 %
Level Line to Ground	
CDN-A-6-200	250 V - 6 kV +10 % / -25 %
CDN-A-8-200	250 V - 8 kV +10 % / -25 %
Front Time	1.2 μs ±30 %
Duration	
Line to Line	50 μs +10 μs/-30 μs
Line to Ground	50 μs +10 μs/-45 μs
Residual Voltage	<12 % of applied test voltage
Level non-surged lines	<12 % of applied test voltage

²⁹. The impedance is freely selectable for all couplings. The calibration is performed according IEC 61000-4-5 with 2Ω/18μF for Line-Line and 12Ω/9μF for Line-PE.

Short Circuit Current

Level Line to Line	
CDN-A-6-200	125 A - 3 kA ± 10 %
CDN-A-8-200	125 A - 3.8 kA ± 10 %
Level Line to Ground	
CDN-A-6-200	20.83 A - 500 A ± 10 %
CDN-A-8-200	20.83 A - 667 A ± 10 %
Front Time	
Line to line	8 μ s ± 20 %
Line to Ground	2.5 μ s ± 30 %
Duration	
Line to line	20 μ s ± 20 %
Line to Ground	25 μ s ± 30 %
Synchronisation	on EUT-Power
Generator	IMU-MGE / IMU3000 IMU-MGS / IMU4000

22.7.4 Ringwave

For ringwave, the additional option OPT-A-x-200 RWG is required. For CDNs with option OPT-A-x-200 FULL RANGE, the technical data of CDN-A-x-125 (when selected 125A range), CDN-A-x-63 (when selected 63A range) or CDN-A-x-32 (when selected 32A range) are applicable.

Standard	IEC 61000-4-12 ANSI C62.45
Coupling	
AC	
Line to Line	L1-L2 L1-L3 L2-L3 Lx-N
Line to Ground	Lx-PE N-PE
with OPT-A-x-200 ANSI	L1&L2&L3&N-PE L1&L2&L3-PE L1&L2&L3-N
DC	
Line to Line	String1+ - String1- String2+ - String2-
Line to Ground	String1+ - PE String1- - PE String2+ - PE String2- - PE
Impedance	12 Ω 30 Ω
Open Circuit Voltage	
Level 12 Ω	
CDN-A-6-200	250 V - 6 kV ±10 %
CDN-A-8-200	250 V - 8 kV ±10 %
Level 30 Ω	
CDN-A-6-200	250 V - 6 kV ±10 %
CDN-A-8-200	250 V - 8 kV ±10 %
Front Time	500 ns ±30 %
Voltage frequency	100 kHz ±10 %
Peak ratio	
Peak2 to Peak1	0.4 to 1.1
Peak3 to Peak2	0.4 to 0.8
Peak4 to Peak3	0.4 to 0.8
Residual Voltage	<12 % of applied test voltage
Level non-surged lines	<12 % of applied test voltage

Short Circuit

Level 12 Ω	
CDN-A-6-200	20.83 A - 500 A +10 % / -25 %
CDN-A-8-200	8.33 A - 666.7 A +10 % / -25 %
Level 30 Ω	
CDN-A-6-200	8.33 A - 200 A +10 % / -25 %
CDN-A-8-200	8.33 A - 266.7 A +10 % / -25 %
Front Time	<1 μs
Synchronisation	on EUT-Power
Generator	IMU-MGE / IMU3000

22.7.5

General

Input Power	
Voltage	100 V - 240 V ±10 %
Frequency	50 Hz - 60 Hz
Consumption	max. 150 VA
Dimensions	60 cm x 65 cm x 105 cm
Weight	tbd kg
Environmental Conditions	
Temperature	10 °C - 35 °C
Humidity	<80 % non condensing
Pressure	86 kPa - 106 kPa
Generator	IMU-MGE / IMU3000 IMU-MGS / IMU4000

22.8

CDN-F-125

22.8.1

EUT

AC	
Lines	L1 / L2 / L3 / N / PE
Voltage	
Line to Line	max. 690 V
Line to Neutral	max. 400 V
Line to Ground	max. 400 V
Current	3 x 125 A
Frequency	50 Hz / 60 Hz
DC	
Lines	String1+ / String1- String2+ / String2-
Voltage	max. 1000 V
Current	max. 125 A

22.8.2

EFT

Standard	IEC 61000-4-4
Coupling	
AC	
calibrated	L1 / L2 / L3 / N / PE to Ground
selectable	individual combination
DC	
calibrated	String1+ / String1- / PE to Ground String2+ / String2- / PE to Ground
selectable	individual combination
Voltage into 50 Ohm	
Level calibrated	500 V - 7.1 kV \pm 10 %
Front Time	5.5 ns \pm 1.5 ns
Duration	45 ns \pm 15 ns
Residual Voltage	<5 % of applied test voltage

22.8.3 General

Dimensions	57 cm x 45 cm x 19 cm / 19" 4HU
Weight	14 kg
Environmental Conditions	
Temperature	10 °C - 35 °C
Humidity	<80 % non condensing
Pressure	86 kPa - 106 kPa
Generator	IMU-MGE / IMU3000 IMU-MGS / IMU4000

22.9 PROT32-690AC / PROT63-690AC / PROT125-690AC / PROT200-690AC

Rated Current	
PROT32-690AC	32 A
PROT63-690AC	63 A
PROT125-690AC	125 A
PROT200-690AC	200 A
Rated Voltage	
AC	690/400 Vac
DC	125 Vdc
Pole	3
Tripping Characteristic	C
Short-circuit Capacity	>3 kA
Dimensions	
PROT32-690AC	24 cm x 16 cm x 9 cm
PROT63-690AC	24 cm x 16 cm x 9 cm
PROT125-690AC	24 cm x 16 cm x 9 cm
PROT200-690AC	57 cm x 45 cm x 19 cm / 19" 4HU
Weight	
PROT32-690AC	1.8 kg
PROT63-690AC	1.8 kg
PROT125-690AC	1.8 kg
PROT200-690AC	13 kg

22.10 PROT32-yyyDC / PROT63-yyyDC / PROT125-yyyDC / PROT200-500DC

Rated Current	
PROT32-yyyDC	32 A
PROT63-yyyDC	63 A
PROT125-yyyDC	125 A
PROT200-500DC	200 A
Rated Voltage	
PROTxx-500DC	500 Vdc
PROTxx-1000DC	1000 Vdc
PROTxx-1500DC	1500 Vdc
Pole	1
Tripping Characteristic	B
Short-circuit Capacity	>5 kA
Dimensions	
PROTxx-yyyDC	24 cm x 16 cm x 9 cm
PROT200-500DC	tbd
Weight	
PROTxx-yyyDC	1.8 kg
PROT200-500DC	tbd

22.11 DC-DC32 / DC-DC63 / DC-DC125 / DC-DC200

Forward Current	
DC-DC32	32 A
DC-DC63	63 A
DC-DC125	125 A
DC-DC200	200 A
Max. EUT Voltage	1500 V
Diode Forward Voltage Drop	max. 3 V
Damping Resistor	1 Ω
	2.2 Ω
	4.7 Ω
	10 Ω
	22 Ω
	47 Ω
	100 Ω
	220 Ω
Standard	IEC 61000-4-5 Ed. 3 Amd. 1
Dimensions	
DC-DC32	30 cm x 23 cm x 11 cm
DC-DC32	30 cm x 23 cm x 11 cm
DC-DC125	57 cm x 45 cm x 19 cm / 19" 4HU
DC-DC200	57 cm x 45 cm x 19 cm / 19" 4HU
Weight	
DC-DC32	4 kg
DC-DC32	5 kg
DC-DC125	16 kg
DC-DC200	20 kg
Power Consumption	
DC-DC32	3 W @ 24 V
DC-DC32	6 W @ 24 V
DC-DC125	32 W @ 115/230 V
DC-DC200	44 W @ 115/230 V

22.12 CDN-DATA

22.12.1 EUT

Max number of lines

CDN-DATA-4L 4 asymmetric

CDN-DATA-8L 8 asymmetric

max. EUT voltage

AC 240 V

DC 200 V

max. EUT current per line

continuous 4 A

for 5 minutes 5 A

Decoupling Inductance 20 mH per line

max. EUT frequency 100 kHz

22.12.2 Surge

Standard IEC 61000-4-5

Coupling resistor 40 Ω

Coupling element 0.5 μ F
33 V bipolar diode
90 V GDT
user defined

Open Circuit

Max. Peak Voltage 6 kV

Rise time 1.2 μ s \pm 30 %

Duration

Line to PE / CD = 0.5 μ F 38 μ s \pm 30 %

Line to PE / CD = GDT 42 μ s \pm 30 %

Line to Line / CD = 0.5 μ F 42 μ s \pm 30 %

Line to Line / CD = GDT 47 μ s \pm 30 %

Short Circuit

Peak current @6 kV

Line to PE / CD = 0.5 μ F 130.5 A \pm 20 %

Line to PE / CD = GDT 142.5 A \pm 20 %

Line to Line / CD = 0.5 μ F 130.5 A \pm 20 %

Line to Line / CD = GDT 142.5 A \pm 20 %

Rise time

CD = 0.5 μ F 1.3 μ s \pm 30 %

CD = GDT 1.5 μ s \pm 30 %

Duration

CD = 0.5 μ F 13 μ s \pm 30 %

CD = GDT 48 μ s \pm 30 %

22.12.3

Ringwave

Standard	IEC 61000-4-12
Coupling element ³⁰	33 V bipolar diode 90 V GDT user defined
Max. peak voltage	6 kV
Voltage rise time	500 ns \pm 30 %
Voltage frequency	100 kHz \pm 10 %
Voltage peak ratio	
Peak2 to Peak1	0.4 to 1.1
Peak3 to Peak2	0.4 to 0.8
Peak4 to Peak3	0.4 to 0.8
Current peak @6 kV	
12 Ω	500 A \pm 20 %
30 Ω	200 A \pm 20 %
Current rise time	0.2 to 1 μ s

22.12.4

General

Dimension	57 cm x 45 cm x 19 cm
Weight	
CDN-DATA-4L	17 kg
CDN-DATA-8L	25 kg
Environmental Conditions	
Temperature	10 °C - 35 °C
Humidity	<80 % non condensing
Pressure	86 kPa - 106 kPa

30. 3 μ F build in the generator

22.13 CDN-KIT1000 ED3

22.13.1 EUT

Max number of lines	2 asymmetric
max. EUT voltage	
AC	240 V
DC	200 V
max. EUT current per line	
continuous	4 A
for 5 minutes	5 A
Decoupling Inductance	20 mH per line
max. EUT frequency	100 kHz

22.13.2 Surge

Standard	IEC 61000-4-5
Coupling resistor	40 Ω
Coupling element	0.5 μ F
Open Circuit	
Max. Peak Voltage	6 kV
Rise time	1.2 μ s \pm 30 %
Duration	
Line to PE	38 μ s \pm 30 %
Line to Line	42 μ s \pm 30 %
Short Circuit	
Peak current @6 kV	
Line to PE	130.5 A \pm 20 %
Line to Line	130.5 A \pm 20 %

22.13.3

General

Dimensions

Universal Coupling Module	16 cm x 10 cm x 5 cm
Universal Decoupling Module	16 cm x 10 cm x 5 cm
Decoupling Module DN2000-22-5	16 cm x 10 cm x 8 cm
CDN-KIT1000 ED3 ³¹	33 cm x 27 cm x 17 cm

Weight

Universal Coupling Module	0.32 kg
Universal Decoupling Module	0.25 kg
Decoupling Module DN2000-22-5	1.44 kg x 2
CDN-KIT1000 ED3 ³²	7 kg

Environmental Conditions

Temperature	10 °C - 35 °C
Humidity	<80 % non condensing
Pressure	86 kPa - 106 kPa

22.14

CDN-UTP ED3 / CDN-UTP8 ED3

31. 4 modules and accessories in carrying case
32. 4 modules and accessories in carrying case

22.14.1

CWG on Asymmetric Lines

Standard	IEC 61000-4-5
Max. Coupling Lines	
CDN-UTP ED3	2 Lines
CDN-UTP8 ED3	4 Lines
Coupling resistor	40 Ω
Coupling element	0.5 μ F 90 V GDT user defined
Open Circuit	
Max. Peak Voltage	6 kV
Rise time	1.2 μ s \pm 30 %
Duration	
Line to PE / CD = 0.5 μ F	38 μ s \pm 30 %
Line to PE / CD = GDT	42 μ s \pm 30 %
Line to Line / CD = 0.5 μ F	42 μ s \pm 30 %
Line to Line / CD = GDT	47 μ s \pm 30 %
Short Circuit	
Peak current @6 kV	
Line to PE / CD = 0.5 μ F	130.5 A \pm 20 %
Line to PE / CD = GDT	142.5 A \pm 20 %
Line to Line / CD = 0.5 μ F	130.5 A \pm 20 %
Line to Line / CD = GDT	142.5 A \pm 20 %
Rise time	
CD = 0.5 μ F	1.3 μ s \pm 30 %
CD = GDT	1.5 μ s \pm 30 %
Duration	
CD = 0.5 μ F	13 μ s \pm 30 %
CD = GDT	48 μ s \pm 30 %

22.14.2 Ringwave on Asymmetric Lines

Standard	IEC 61000-4-12
Max. Coupling Lines	
CDN-UTP ED3	2 Lines
CDN-UTP8 ED3	4 Lines
Coupling element ³³	90 V GDT user defined
Open Circuit	
Max. Peak Voltage	6 kV
Rise time	500 ns \pm 30 %
Frequency	100 kHz \pm 10 %
Peak ratio	
Peak2 to Peak1	0.4 to 1.1
Peak3 to Peak2	0.4 to 0.8
Peak4 to Peak3	0.4 to 0.8
Short Circuit	
Current peak @6 kV	
12 Ω	500 A \pm 20 %
30 Ω	200 A \pm 20 %
Rise time	0.2 to 1 μ s

22.14.3 CWG on Symmetric Lines

Standard	IEC 61000-4-5 ITU K20 K21 K44
Max. Coupling Lines	
CDN-UTP ED3	4 Lines / 2 Pairs
CDN-UTP8 ED3	8 Lines / 4 Pairs
Coupling Resistor	
1 Pair	2 x 80 Ω
2 Pairs	4 x 160 Ω
4 Pairs	8 x 320 Ω
Coupling element	0.5 μ F 90 V GDT user defined
Open Circuit	
Max. Peak Voltage ³⁴	6 kV
Rise time	1.2 μ s \pm 30 %
Duration	45 μ s \pm 30 %
Short Circuit	
Peak current	144 A \pm 30 % @ 6kV
Rise time	1.5 μ s \pm 30 %
Duration	45 μ s \pm 30 %

33. 3 μ F build in the generator

34. all values with CD = 90 V GDT

22.14.4

Ringwave on Symmetric Lines

Standard	IEC 61000-4-12 ITU K20 K21 K44
Max. Coupling Lines	
CDN-UTP ED3	4 Lines / 2 Pairs
CDN-UTP8 ED3	8 Lines / 4 Pairs
Coupling element	90 V GDT user defined
Open Circuit	
Max. Peak Voltage	6 kV
Rise time	500 ns \pm 30 %
Frequency	100 kHz \pm 10 %
Peak ratio	
Peak2 to Peak1	0.4 to 1.1
Peak3 to Peak2	0.4 to 0.8
Peak4 to Peak3	0.4 to 0.8
Short Circuit	
Current peak @6 kV	
12 Ω	500 A \pm 20 %
30 Ω	200 A \pm 20 %
Rise time	0.2 to 1 μ s

22.14.5 Telecom on Symmetric Lines

Standard	IEC 61000-4-5 ITU K20 K21 K44
Max. Coupling Lines	
CDN-UTP ED3	4 Lines / 2 Pairs
CDN-UTP8 ED3	8 Lines / 4 Pairs
Coupling Resistor	
1 Pair	2 x 25 Ω
2 Pairs	4 x 25 Ω
4 Pairs	8 x 25 Ω
Coupling element	
	90 V GDT user defined
Open Circuit	
Max. Peak Voltage	6 kV
Rise time	8 μ s \pm 30 %
Duration ³⁵	250 μ s \pm 30 %
Short Circuit	
Peak current	217.5 A \pm 20 % @ 6kV
Rise time	3.2 μ s \pm 30 %
Duration	250 μ s \pm 30 %

22.14.6 EUT

max. EUT voltage	
with CD = GDT	90 V
with CD = 0.5 μ F	300 V
with CD = User defined	300 V
max. EUT current per line ³⁶	1 A
Decoupling Inductance	20 mH per line
Auxiliary Equipment Protection	90 V GDT user defined

35. Up to 5 kV

36. total for all lines max. 2 A

22.14.7

General

Dimension	
CDN-UTP ED3	57 cm x 45 cm x 19 cm / 19" 4HU
CDN-UTP8 ED3	60 cm x 45 cm x 37 cm / 19" 8HU
Weight	
CDN-UTP ED3	40 kg
CDN-UTP8 ED3	78 kg
Environmental Conditions	
Temperature	10 °C - 35 °C
Humidity	<80 % non condensing
Pressure	86 kPa - 106 kPa

22.15

ADAPTER BOX RJ45

max. Surge Level ³⁷	1500 V
Dimension	16 cm x 8 cm x 3 cm
Weigth	0.2 kg

22.16

EXT-IMU E

Standards ³⁸	IEC 61000-4-2:2008 ISO 10605 ITU-T K.20 MIL-STD-461G CS118 DO-160 Section 25
Storage Capacitance	150 pF
Discharge Resistance	330 Ω
Voltage Holding Time	>= 5 s
Contact Discharge into 2 Ω	
Level / Ouput Voltage ³⁹	
selectable	2 kV - 16 kV
guaranteed	2 kV - 10 kV ±5 %
Current Peak	7.5 A @ 2kV - 37.5 A @ 10kV ±15 %
Current @30ns	4 A @ 2kV - 20 A @ 10kV ±30 %
Current @60ns	2 A @ 2kV - 10 A @ 10kV ±30 %
Rise time	0.8 ns ±25 %
Air Discharge	
Level / Output Voltage ⁴⁰	
selectable	2 kV - 16 kV
guaranteed	2 kV - 15 kV ±5 %

37. Limitation due to the pin spacing of the RJ45-Plug.

38. Standard Calibration according IEC 61000-4-2. Calibration according ISO 10605 is available upon request.

39. For exploratory purposes, a wider voltage range can be selected. The extended range itself and all other parameter within this range are not guaranteed.

40. For exploratory purposes, a wider voltage range can be selected. The extended range itself and all other parameter within this range are not guaranteed.

Polarity	positive negative alternating
Trigger Mode	automatic manual
Repetition Counter	0.05 s - 30 s 1 - 30000
Count Mode	every pulse only discharges
Dimensions	37 cm x 12 cm x 8 cm
Weight	0.7 kg
Environmental Conditions	
Temperature	10 °C - 35 °C
Humidity	30 % - 60 % non condensing
Pressure	86 kPa - 106 kPa

22.17 ESD-TARGET2 / ESD-TARGET2 DN

Standard	IEC 61000-4-2
Input Impedance	2 Ω
Attenuator	
ESD-TARGET2	1 x 20 dB
ESD-TARGET2 DN	1 x 20 dB 2 x 20 dB
Max. Input Voltage (ESD Impulse)	
with 1 x 20 dB	10 kV
with 2 x 20 dB	30 kV
Input / Output Ratio	
with 1 x 20 dB	0.2 V / 1 A
with 2 x 20 dB	0.02 V / 1 A
Max. Impulse Current	
with 1 x 20 dB	50 A
with 2 x 20 dB	120 A
Tolerance of Insertion Loss	
up to 1 GHz	±0.5 dB
up to 4 GHz	±1.2 dB
Cable	1 m Coax Cable with SMA-Connector
Dimension	Diameter 7 cm x 4 cm
Weight	0.4 kg

22.18 ESD-VERI-V

Input Impedance	20 GΩ 3 pF
Max. Input Voltage	32 kV
Input / Output Ratio ⁴¹	1 : 20'000
Output Connector	BNC
Dimension	Diameter 5.5 cm x 17 cm
Weight	0.43 kg

22.19 ESD-STAND Ed2

Height	50 cm - 180 cm
Position	360° adjustable
Dimensions	64 cm x 17 cm x 12 cm (packed)
Weight	4 kg

22.20 ESD-VCP50

Standard	IEC 61000-4-2
Dimensions	
Coupling Plane	50 cm x 50 cm x 0.1 cm
Insulation	10 cm
Material	Stainless Steel
Weight	8 kg

⁴¹. with an 1 MΩ external divider resistor. If a voltage measurement equipment with 10 MΩ is used, a 1.111 MΩ resistor in parallel is needed to get a total resistance of 1 MΩ.

22.21 EARTH CABLE

Length	2m
Impedance	2 x 470 Ω
Connector	4 mm banana plugs

22.22 EFT INSULATION

Height	10 cm
Surface	100 x 40 cm (2 plates 50 x 40 cm each)
EUT Weight	max. 50 kg
Weigth	16 kg (2 plates)

22.23 CN-EFT1000

Standard	IEC 61000-4-4 IEC 61000-4-18:2019
Insulation	
EFT 5 ns / 50 ns	8 kV
DOW 3 MHz / 10 MHz / 30 MHz	5 kV
CWG 1.2 us / 50 us	5 kV
Usable cable diameter	up to 70 mm
Coupling capacitance	typically 100 pF - 1000 pF
EFT Calibration into 50 Ω	
Level	1000 V ±20 %
Rise time	5 ns ±1.5 ns
Duration	50 ns ±15 ns
DOW Calibration into 50 Ω	
Level	1000 V ±20 %
Frequency	3 MHz ±20 % 10 MHz ±20 % 30 MHz ±20 %
Dimensions	114 cm x 15 cm x 10 cm
Weight	4 kg

22.24 VERI-CP-EFT

Standard	IEC 61000-4-4 IEC 61000-4-18:2019
Dimension of the metallic part	
Width	120 mm \pm 1 mm
Length	1050 mm \pm 1 mm
Overall Dimension	113 cm x 7 cm x 5 cm
Insulation	
EFT 5 ns / 50 ns	7.1 kV
DOW 3 MHz / 10 MHz / 30 MHz	4.4 kV
CWG 1.2 us / 50 us	>2.5 kV
Weight	1 kg

22.25 VERI50 EFT

Impedance	50 Ω \pm 2 %
Ratio	
50 Ω DSO Input	1:1000 \pm 2 %
1 M Ω DSO Input	1:500
Tolerance of Insertion Loss	
up to 100MHz	\pm 0.5 dB
up to 400MHz	\pm 3 dB
Max. Level	7100 V EFT- or DOW-Impulse
Max. average Spikes/s	350 @7100 V
Dimension	15.5 cm x 2.5 cm x 2.5 cm
Weight	0.1 kg

22.26 VERI1K EFT

Impedance	1000 $\Omega \pm 2\%$
DC Ratio	
50 Ω DSO Input	1:2000
1 M Ω DSO Input	1:1000 $\pm 3\%$
Tolerance of Insertion Loss	
up to 100MHz	± 0.5 dB
up to 400MHz	± 3 dB
Max. Level	7100 V EFT- or Fast-DOW-Impulse
Max. average Spikes/s	350 @7100 V
Dimension	13.5 cm x 2.5 cm x 2.5 cm
Weight	0.1 kg

22.27 CN-BALUN-AC

Standard	IEC 61000-4-4 ANSI C37.90 Fig.6 ISO7637-4
Input	7.1 kV EFT signal common mode
Output	7.1 kV signal differential mode line to line
Max. EUT Voltage	480 V L-L @ 50/60 Hz
Decoupling	2 x 66 nF built-in
Dimensions	18 cm x 10 cm x 8 cm
Weight	2 kg

22.28 CN-R40C05 / CN-R40C05 8

Standard	IEC 61000-4-5 IEC/EN 50121-4
Coupling Lines	2
Test type	Surge on 2 unsymmetrical lines
Test level surge	
CN-R40C05	6 kV
CN-R40C05 8	8 kV
Low speed I/O	unsymmetrical coupling with capacitor
Coupling path	40 Ω+ 0.5 μF
EUT voltage ⁴²	440 V AC/DC
Dimensions	20 cm x 10 cm x 11 cm
Weight	1 kg

22.29 V-PROBE-SI

Bandwidth	DC to 70 MHz (-3 dB)
Attenuation Ratio	1:100 1:1000
Accuracy	±2 %
Input Impedance	10 MΩ 10 pF
Max. RMS Input Voltage	2.5 kV
Max. Peak Input Voltage	7 kV
Power Supply	4 AA batteries Mains Adapter
Dimension	20 cm x 8 cm x 4 cm
Weight	0.5 kg

42. The maximum EUT current is only limited by the decoupling element.

22.30 I-PROBE-P101

Bandwidth	0.25 Hz to 4 MHz (-3 dB)
Attenuation Ratio	0.01 V/A
Accuracy	+1/-0 %
Output Impedance	50 Ω
Max. RMS Current	200 A
Max. Peak Current	5 kA
Dimension	12 cm x 10 cm x 3 cm inner diameter 5 cm
Weight	1 kg

22.31 MF1000-1

Standard	IEC 61000-4-8 IEC 61000-4-9 IEC 61000-4-10
Coil Size	1 m x 1 m
Coil Factor	0.87
AC Magnetic field ⁴³	
Range 1	0.8 A/m - 5.0 A/m continuous
Range 2	5.0 A/m - 40 A/m continuous
Range 3	40 A/m - 160 A/m continuous
CWG Magnetic field ⁴⁴	
8/20 μ s	93 A/m - 1855 A/m
DOW Magnetic field ⁴⁵	
100 kHz	5 A/m - 220 A/m
1 MHz	2.5 A/m - 110 A/m
Dimensions	120 cm x 100 cm x 10.5 cm
Weight	6 kg

43. Effective range depends on generator. See technical specification of IMU-Generators.

44. Effective range depends on generator. See technical specification of IMU-Generators.

45. Effective range depends on generator. See technical specification of DOW-Generators.

22.32 DIPS100E

Standard	IEC 61000-4-11 IEC 61000-4-34
Impedance	100 $\Omega \pm 5\%$
Power Rating	1000 W
Dimension	65 cm x 12 cm x 8 cm
Weight	3.8 kg

22.33 VAR-EXT1000

Input	
Voltage	50 V - 250 V
Frequency	50/60 Hz
Current	Max. 16 A
Output 1	
Voltage	100 % of input voltage 50 % of input voltage
Current	Max. 16 A
Output 2	
Voltage	
Dips	0-110 % of input voltage max. 275 V
Variations	0-100 % of input voltage max. 250 V
Voltage slew rate	< 1.7 s from 0 to 100 %
Current	Max. 16 A
Dimensions	57 cm x 45 cm x 19 cm / 19" 4HU
Weight	29 kg

22.34 SRC16-1P

Input Voltage	max. 300 V
Frequency	50/60 Hz
Output Voltage at no load ⁴⁶	100% of $V_{in} \pm 5\%$ 80% of $V_{in} \pm 5\%$ 70% of $V_{in} \pm 5\%$ 40% of $V_{in} \pm 5\%$
Continuous Output Current	16 A
Short Time Output Current	
80 %	20 A for 5 s
70 %	23.6 A for 5 s
40 %	40 A for 3 s
Voltage change with load ⁴⁷	<5 % of Input Voltage
Dimensions	28 cm x 23 cm x 10 cm
Weight	17.5 kg

22.35 VERI-DIPS

Standard	IEC 61000-4-11 IEC 61000-4-34
Current range	1 A - 1 kA
Max. Voltage	280 V rms
Voltage application time	5 s standard 30 s maximum
Capacitance	1700 $\mu\text{F} \pm 20\%$
Discharge resistor	4.7 $\text{k}\Omega \pm 10\%$
DSO output	1 V = 400 A BNC connector
Dimensions	20 cm x 10 cm x 11 cm
Weight	1 kg

46. The tolerance is related to the residual voltage as defined in IEC61000-4-11.

47. With an input voltage >100 V

22.36 SRC32-18UH / SRC32-AMD1

Voltage	
AC, line-to-line	200 - 480 V 50/60 Hz
AC, line-to-neutral	Min. 100 - 280 V 50/60 Hz
line or neutral to PE	Max. 280 V 50/60 Hz
Output Voltage ⁴⁸	
SRC32-18UH	100 %
	80 %
	70 %
	40 %
	0 %
SRC32-AMD1	100 %
	80 %
	70 %
	50 %
	40 %
0 %	
Output current	
Nominal	32 A
At 80 % dip	40 A
At 70 % dip	46 A
At 50 % dip ⁴⁹	64 A
At 40 % dip ⁵⁰	80 A
Over-current protection	
continuous	50 A
short duration <2 s	220 A
Inrush current	
	500 A
Dimensions	
	60 cm x 65 cm x 105 cm / 19" 18HU
Weight	
SRC32-18UH	307 kg
SRC32-AMD1	317 kg

48. At no load.

49. Only for SRC32-AMD1. Max. 3 s, due to overcurrent protection.

50. Max. 3 s, due to overcurrent protection.

22.37

PFS32

EUT	
Voltage	
AC, line-to-line	200 - 480 V 50/60 Hz
AC, line-to-neutral	Min. 100 - 280 V 50/60 Hz
DC voltage	Max. 500 V
Frequency range	
DC - 400 Hz	
Current	
Max. 32 A per line	
Synchronization	
line-to-line line-to-neutral	
Over-current protection	
continuous	50 A
short duration <2 s	220 A
AC Interrupts	
Standard	
IEC 61000-4-11 IEC 61000-4-34	
Rise & fall time ⁵¹	1 - 5 μ s
Interruption time	50 μ s - 60 s
Interrupt current	32 A
Inrush current ⁵²	500 A
Interrupt synchronizatoin	0° - 359° \pm 1°
DC Interrupts	
Standard	
IEC 61000-4-29	
Rise & fall time ⁵³	1 - 50 μ s
Interruption time	1 ms - 60 s
Interrupt current	32 A
Output monitor BNC	3 x Current (1 V : 100 A) 3 x Voltage (1 V : 100 V)
Dimensions	57 cm x 45 cm x 19 cm / 19" 4HU
Weight	26 kg

51. 10-90 % \times 1.25, into 100 Ω

52. The public power supply must be capable to deliver the 500 A.

53. 10-90 % \times 1.25

22.38 SRC75-18UH / SRC75-690

Line-Line Voltage	
SRC75-18UH	200 - 480 V 50/60 Hz
SRC75-690	200 - 690 V 50/60 Hz
Line-Neutral Voltage	
SRC75-18UH	100 - 280 V 50/60 Hz
SRC75-690	100 - 400 V 50/60 Hz
Line/Neutral-PE Voltage	
	max. 280 V
Output Voltage ⁵⁴	
	100 %
	80 %
	70 %
	40 %
	0 %
Output current	
Nominal	75 A
At 80 % dip	75 A
At 70 % dip	75 A
At 40 % dip ⁵⁵	75 A
Over-current protection	
continuous	75 A
short duration <2 s	220 A
Inrush current	
	1000 A
Dimensions	
	60 cm x 65 cm x 105 cm / 19" 18HU
Weight	
SRC75-18UH	332 kg
SRC75-690	tbd kg

54. At no load.

55. Max. 3 s, due to overcurrent protection.

22.39 PFS75 / PFS75-690

EUT	
Line-Line Voltage	
PFS75	200 - 480 V 50/60 Hz
PFS75-690	200 - 6900 V 50/60 Hz
Line-Neutral Voltage	
PFS75	100 - 280 V 50/60 Hz
PFS75-690	100 - 400 V 50/60 Hz
DC Voltage	
Max. 500 V	
Frequency range	
DC - 400 Hz	
Current	
Max. 75 A per line	
Synchronization	
line-to-line line-to-neutral	
Over-current protection	
continuous	75 A
short duration <2 s	220 A
AC Interrupts	
Standard	IEC 61000-4-11 IEC 61000-4-34
Rise & fall time ⁵⁶	1 - 5 μ s
Interruption time	50 μ s - 60 s
Interrupt current	75 A
Inrush current ⁵⁷	500 A
Interrupt synchronizatoin	0° - 359° \pm 1°
DC Interrupts	
Standard	IEC 61000-4-29
Rise & fall time ⁵⁸	1 - 50 μ s
Interruption time	1 ms - 60 s
Interrupt current	32 A
Output monitor BNC	3 x Current (1 V : 100 A) 3 x Voltage (1 V : 100 V)
Dimensions	60 cm x 45 cm x 37 cm / 19" 8HU
Weight	
PFS75	40 kg
PFS75-690	54 kg

56. 10-90 % \times 1.25, into 100 Ω

57. Not limited by test system. The public power supply must be capable to deliver the 500 A.

58. 10-90 % \times 1.25

22.40 RESISTOR 50 Ohm

Standard	IEC 61000-4-29
Impedance	50 $\Omega \pm 5\%$
Power Rating	1000 W
Dimension	65 cm x 12 cm x 8 cm
Weight	3.8 kg

22.41 PS3

Input ratings	
Voltage range	90 V - 264 V
Frequency range	47 Hz - 63 Hz
Max. Current	16 A @ 230 V 20 A @ 115 V
Power factor	0.98 @ $V_{in} = 100$ V 0.95 @ $V_{in} = 200$ V
Fuse	Melting fuse 20 AT type C
Output ratings	
Voltage range	50 V - 250 V AC ± 10 V to ± 350 V DC
Frequency range	16.7 Hz to 400 Hz
Voltages (pre-programmed)	230 V / 50 Hz 230 V / 16.7 Hz 115 V / 60 Hz 115 V / 400 Hz
Max. Current ⁵⁹	16 A
Max. power ⁶⁰	< 1 % @ 50/60 Hz
THD ⁶¹	3000 W or 3000 VA
Accuracy	
Frequency	< 0.3 % @ 16.7/50/60 Hz < 0.6 % @ 400 Hz
AC voltage	2 %
DC voltage	± 1.5 V from ± 10 to ± 49 V @ 1 A load ± 3 V from ± 50 to ± 150 V @ 0.5 A load ± 2 % from ± 151 to ± 350 @ no load
Environmental Conditions	
Temperature	0 °C - 45 °C
Humidity	<80 % non condensing
Pressure	86 kPa - 106 kPa
Dimensions	57 cm x 45 cm x 10 cm / 19" 2HU
Weight	18 kg

59. see derating curve

60. measured into a 1000 W resistive load

61. output rating can only be reached with available public power supply of 230V/16A or 115V/20A

22.42 RS485-RS232 ADAPTER

Connectors	RS485 x 1 RS232 x 2
Length	3 m
Weigth	0.1 kg

22.43 EXT-IMU C-SHORT

Requires EXT-IMU C and PS3 power supply.

Standard	IEC 61000-4-16
Voltage	30 V - 330 V \pm 10 %
Power frequencies	DC 16.67 Hz 50 Hz 60 Hz
Output impedance	50 Ω \pm 10 %
Repetition	1 - 6000 s
Duration	1 - 1000 s
Max. Output Power	
Short Time ⁶²	5 kW
Continious ⁶³	250 W
Dimensions	57 cm x 45 cm x 19 cm / 19" 4HU
Weight	54 kg

62. Calculated by $[\text{Output Current}]^2 * 50 \Omega * [\text{Duration}]$

63. Calculated by $[\text{Output Current}]^2 * 50 \Omega * [\text{Duration}]/[\text{Repetition}]$. The repetition is no longer considered if the duration is longer than 30 s.

22.44

CN16 / CN16-8L

Standard	IEC 61000-4-16
max. Coupling Lines	
CN16	4
CN16-8L	8
Test type	
DC Disturbances	
AC Disturbances	16.7 Hz 50 Hz 60 Hz Frequency Sweep
Coupling Resistor	
1 Line	1 x 100 $\Omega \pm 10\%$
2 Lines	2 x 200 $\Omega \pm 10\%$
4 Lines	4 x 400 $\Omega \pm 10\%$
8 Lines	8 x 800 $\Omega \pm 10\%$
Resistor Matching	<1 %
Coupling Capacitor ⁶⁴	1 $\mu\text{F} \pm 10\%$ per line
Capacitor Matching	<1 %
Max. Test Level	
Short Duration Disturbance	330 V
Continuous Disturbance	35 V
Max. EUT Voltage ⁶⁵	
AC Disturbances	280 Vrms Line - Neutral/PE 480 Vrms Line - Line
DC Disturbances	115 Vrms
Dimensions	
CN16	28 cm x 18 cm x 11 cm
CN16-8L	28 cm x 23 cm x 11 cm
Weight	
CN16	3 kg
CN16-8L	4 kg

64. For DC-Tests, the coupling capacitor is bypassed

65. The maximum EUT current is only limited by the decoupling element.

22.45 CN16-300

Standard	IEC 61000-4-16
Coupling Lines	3
Test type	
DC Disturbances	
AC Disturbances	16.7 Hz 50 Hz 60 Hz Frequency Sweep
Coupling Resistor	3 x 300 Ω±10 %
Resistor Matching	<1 %
Coupling Capacitor ⁶⁶	1 μF ±10 % per line
Capacitor Matching	<1 %
Max. Test Level	
Short Duration Disturbance	330 V
Continuous Disturbance	35 V
Max. EUT Voltage ⁶⁷	
AC Disturbances	280 Vrms Line - Neutral/PE 480 Vrms Line - Line
DC Disturbances	115 Vrms
Dimensions	28 cm x 18 cm x 11 cm
Weight	3 kg

22.46 CN16DC

Standard	IEC 61000-4-16
Coupling Lines	2
Test type	DC Disturbances
Coupling Resistor	2 x 200 Ω±10 %
Resistor Matching	<1 %
Max. Test Level	
Short Duration Disturbance	330 V
Continuous Disturbance	35 V
Max. EUT Voltage ⁶⁸	250 V
Dimensions	28 cm x 18 cm x 11 cm
Weight	3 kg

66. For DC-Tests, the coupling capacitor is bypassed

67. The maximum EUT current is only limited by the decoupling element.

68. The maximum EUT current is only limited by the decoupling element.

22.47

CN16T / CN16T4

Standard	IEC 61000-4-16
Coupling Lines	
CN16T	2
CN16T4	4
Test type	
DC Disturbances	
AC Disturbances	16.7 Hz 50 Hz 60 Hz Frequency Sweep
Coupling Resistor	
CN16T	2 x 200 $\Omega \pm 10\%$
CN16T4	4 x 400 $\Omega \pm 10\%$
Resistor Matching	<1 %
Coupling Capacitor ⁶⁹	4.7 $\mu\text{F} \pm 10\%$ per line
Capacitor Matching	<1 %
Inductance	38 mH per line
Max. Test Level	
Short Duration Disturbance	330 V
Continuous Disturbance	35 V
Max. EUT Voltage	
AC Disturbances	250 V
DC Disturbances	110 V
Max. EUT Current	0.5 A
Dimensions	28 cm x 18 cm x 11 cm
Weight	3 kg

69. For DC-Tests, the coupling capacitor is bypassed

22.48 CN16T8

Standard	IEC 61000-4-16
Coupling Lines	8
Test type	
DC Disturbances	
AC Disturbances	16.7 Hz 50 Hz 60 Hz Frequency Sweep
Coupling Resistor	8 x 800 $\Omega \pm 10\%$
Resistor Matching	<1 %
Coupling Capacitor ⁷⁰	4.7 $\mu\text{F} \pm 10\%$ per line
Capacitor Matching	<1 %
Coupling Inductance	38 mH per line
Max. Test Level	
Short Duration Disturbance	330 V
Continuous Disturbance	35 V
EUT / AE Connector	RJ45
EUT Line Speed	1 Gbps
Decoupling Inductance	38 mH per line
Max. EUT Voltage	100 V
Max. EUT Current	0.5 A
Dimensions	28 cm x 23 cm x 11 cm
Weight	4 kg

22.49 CN16-22-7C

Standard	IEC 60255-22-7
Coupling Lines	2
Coupling Mode	Common Mode
Test type	
AC Disturbances	16.7 Hz 50 Hz 60 Hz
Coupling Resistor	2 x 220 $\Omega \pm 5\%$
Resistor Matching	<1 %
Coupling Capacitor	0.47 $\mu\text{F} \pm 5\%$ per line
Capacitor Matching	<1 %
Max. Test Level	330 V
Max. EUT Voltage ⁷¹	
AC Disturbances	415 V
Dimensions	28 cm x 18 cm x 11 cm
Weight	3.3 kg

70. For DC-Tests, the coupling capacitor is bypassed

71. The maximum EUT current is only limited by the decoupling element.

22.50 CN16-22-7D

Standard	IEC 60255-22-7
Coupling Lines	2
Coupling Mode	Differential Mode
Test type	
AC Disturbances	16.7 Hz 50 Hz 60 Hz
Coupling Resistor	2 x 100 Ω ± 5 %
Resistor Matching	<1 %
Coupling Capacitor	
Class A	0.1 μF ± 5 % per line
Class B	0.047 μF ± 5 % per line
Capacitor Matching	<1 %
Max. Test Level	330 V
Max. EUT Voltage ⁷²	
AC Disturbances	415 V
Dimensions	28 cm x 18 cm x 11 cm
Weight	3.5 kg

22.51 DN16-1P6 / DN16-1P16

Standard	IEC 61000-4-16
Ratio	1:1
Input Voltage	max. 230 V 50/60 Hz
Current	
DN16-1P6	max. 6A
DN16-1P6	max. 16A
Insulation	>1 kV
CM Decoupling	>60 dB in the range 15 Hz - 150 kHz
Dimensions	57 cm x 45 cm x 19 cm
Weight	
DN16-1P6	30 kg
DN16-1P6	50 kg

72. The maximum EUT current is only limited by the decoupling element.

22.52 IMU SLAVE SMART I1V1

22.52.1 IMU SLAVE SMART V1

Standard	IEC 61000-4-19
EUT	
EUT voltage	80-500 V L-L or L-N
Frequency	50 - 400 Hz
Current	max. 16 A
Voltage test generator	
Waveform	sinsuoidal THD < 5%
Level	0.1 V - 25 V
Frequency	2 kHz - 150 kHz
Output impedance	10 Ω \pm 30 % 2-150 kHz
CDN decoupling ⁷³	< -10 dB @ 10 kHz < -50 dB @ 50 kHz < -50 dB @ 150 kHz
Frequency step	1 % - 100 %
Dwell time	1 s - 300 s
Signal type	continuous with pause rectangular modulation
Modulation frequencies	1 Hz - 1000 Hz
Calibration load	10 Ω load built-in switched automatically

73. CDN Surpasses minimal requirements from IEC 61000-4-19, use VERI10-50 to verify CDN decoupling.

22.52.2

IMU SLAVE SMART I1

Standard	IEC 61000-4-19
EUT	
Voltage	80-500 V L-L or L-N
Frequency	50 - 400 Hz
Current	max. 25 A
Current test generator	
Waveform	sinsuoidal THD < 5%
Levels	0.01 A - 4.4 A
Frequency	2 kHz - 150 kHz
Output impedance	1 Ω \pm 30 % 2-150 kHz
Frequency step	1 % - 100 %
Dwell time	1 s - 300 s
Signal type	continuous with pause rectangular modulation
Modulation frequencies	1 Hz - 1000 Hz
Calibration load	10 Ω load built-in switched automatically
Load current source CS25	
Load current	
50/60 Hz	1 - 25 A
400 Hz	1 - 15 A
Decoupling impedance	> 1 Ω integrated
Synchronization	to EUT voltage

22.52.3 IMU SLAVE SMART Main

Input Power	
Voltage	100 V - 240 V \pm 10 %
Frequency	50 Hz - 60 Hz
Current	max. 5 A
Consumption	
Switched off	0 VA
Standby	<15 VA
Test running	max. 400 VA
Dimensions	57 cm x 45 cm x 19 cm / 19" 4HU
Weight	
IMU SLAVE SMART I1	18 kg
IMU SLAVE SMART V1	17 kg
IMU SLAVE SMART I1V1	22 kg
Environmental Conditions	
Temperature	10 °C - 35 °C
Humidity	<80 % non condensing
Pressure	86 kPa - 106 kPa

22.53 VERI10-50

Standard	IEC 61000-4-19
Input impedances	2 x 10 Ω \pm 10 %
Outpt impedances	2 x 50 Ω \pm 10 %
Frequency response	2 kHz - 200 kHz \pm 0.5 dB
Dimension	24 cm x 9 cm x 8 cm
Weight	1.2 kg

22.54 EMERGENCY-STOP

Cable Length	5 m
Dimensions	8 cm x 8 cm x 10 cm
Weigth	0.3 kg

22.55 WARNING-LAMP

Cable Length	5 m
Dimensions	diameter 7 cm x 25 cm
Weigth	0.5 kg