



Advanced Test Equipment Rentals
www.atecorp.com 800-404-ATEC (2832)



RF & MICROWAVE SCALAR ANALYZERS
6820A SERIES
and
RF & MICROWAVE SYSTEM ANALYZERS
6840A SERIES



Operating Manual

Document part no. 46892/920

**RF & MICROWAVE SCALAR ANALYZERS
6820A SERIES**

and

**RF & MICROWAVE SYSTEM ANALYZERS
6840A SERIES**

© Aeroflex International Ltd. 2008

*No part of this document may be reproduced or transmitted in any form
or by any means, electronic or mechanical, including photocopying,
or recorded by any information storage or retrieval system,
without permission in writing by Aeroflex International Ltd.
(hereafter referred to throughout the document as 'Aeroflex').*

Manual part no. 46892/920 (PDF version)

Based on Issue 1 of the printed manual
26 September 2008

About this Manual

This manual explains how to use the 6820A Series Scalar Analyzers and the 6840A Series System Analyzers.

Intended Audience

Persons engaged on work relating to the design and manufacture of RF and microwave sub-systems and modules, or the installation and maintenance of those systems.

It is assumed that the reader is familiar with the terms used in RF and microwave measurements.

Structure

Chapter 1

Provides an introduction to the 6800A Series of instruments. It also includes complete performance data and lists the versions, options and accessories available.

Chapter 2

Installation details, including connecting to an AC supply, goods-in checks and routine maintenance

Chapter 3

Illustrates the features of the instrument and describes manual operation from the front panel.

Chapter 4

Brief technical description and block diagram of the instrument.

Chapter 5

Acceptance testing procedures to verify that the instrument is functioning correctly.

Document conventions

The following conventions apply throughout this manual:-

CAPS Capitals are used to identify names of controls and panel markings.

[CAPS] Capitals in square brackets indicate hard key titles.

[Italics] Italics in square brackets indicate soft key titles.

[Averaging ●] A '●' after a soft key title indicates that the key has a toggle action, and that the function is enabled.

[Averaging ○] A '○' after a soft key title indicates that the key has a toggle action, and that the function is disabled.

Associated publications

There are three other publications covering specific aspects of this equipment:-

- **Getting Started** (46892/922). Provides example measurement procedures covering common RF and microwave measurements.
- **Remote Operating Manual** (46892/921). Provides information for controlling the instrument remotely using either the GPIB or RS-232 interfaces.
- **Service Manual** (46880/122). Optional purchase providing information for maintenance, adjustment, calibration and repair.

Contents

	Tab numbers	
Preface		
Precautions		
Chapter 1	GENERAL INFORMATION	1
Chapter 2	INSTALLATION	2
Chapter 3	LOCAL OPERATION	3
	DISPLAY group keys	4
	CHANNEL MODE group keys	5
	SETUP & ANALYSIS group keys	6
	SYSTEM group keys	7
Chapter 4	BRIEF TECHNICAL DESCRIPTION	8
Chapter 5	ACCEPTANCE TESTING	9
Appendices		10
Appendix A	INSTRUMENT DEFAULT SETTINGS	
Appendix B	ERROR MESSAGES	
Appendix C	FAULT LOCATION MEASUREMENT PRINCIPLES	
INDEX		11
ADDRESSES		12

Precautions

WARNING

CAUTION

Note

These terms have specific meanings in this manual:

WARNING

information to prevent personal injury.

CAUTION





information to prevent damage to the equipment.

Note

important general information.

Symbols

The meaning of hazard symbols appearing on the equipment and in the documentation is as follows:

Symbol	Description
	Refer to the operating manual when this symbol is marked on the instrument. Familiarize yourself with the nature of the hazard and the actions that may have to be taken.
	Dangerous voltage
	Toxic hazard
	Static sensitive components

General conditions of use

This product is designed and tested to comply with the requirements of IEC/EN61010-1 'Safety requirements for electrical equipment for measurement, control and laboratory use', for Class I portable equipment and is for use in a pollution degree 2 environment. The equipment is designed to operate from an installation category II supply.

Equipment should be protected from the ingress of liquids and precipitation such as rain, snow, etc. When moving the equipment from a cold to a hot environment, it is important to allow the temperature of the equipment to stabilise before it is connected to the supply to avoid condensation forming. The equipment must only be operated within the environmental conditions specified in 'Performance data' in Chapter 1 of the Operating manual, otherwise the protection provided by the equipment may be impaired.

This product is not approved for use in hazardous atmospheres or medical applications. If the equipment is to be used in a safety-related application, e.g. avionics or military applications, the suitability of the product must be assessed and approved for use by a competent person.

WARNING



Electrical hazards (AC supply voltage)

This equipment conforms with IEC Safety Class I, meaning that it is provided with a protective grounding lead. To maintain this protection the supply lead must always be connected to the source of supply via a socket with a grounded contact.

Be aware that the supply filter contains capacitors that may remain charged after the equipment is disconnected from the supply. Although the stored energy is within the approved safety requirements, a slight shock may be felt if the plug pins are touched immediately after removal.

Do not remove instrument covers as this may result in personal injury. There are no user-serviceable parts inside.

Refer all servicing to qualified personnel. See list of Service Centers at rear of manual.

Fuses

Note that there are supply fuses in both the live and neutral wires of the supply lead. If only one of these fuses should rupture, certain parts of the equipment could remain at supply potential.

WARNING



Fire hazard

Make sure that only fuses of the correct rating and type are used for replacement.

If an integrally fused plug is used on the supply lead, ensure that the fuse rating is commensurate with the current requirements of this equipment. See Chapter 1 for power requirements.

WARNING



Toxic hazards

Some of the components used in this equipment may include resins and other materials which give off toxic fumes if incinerated. Take appropriate precautions, therefore, in the disposal of these items.

WARNING



Beryllium copper

Some mechanical components within this instrument are manufactured from beryllium copper. This is an alloy with a beryllium content of approximately 5%. It represents no risk in normal use.

The material should not be machined, welded or subjected to any process where heat is involved.

It must be disposed of as “special waste”.

It must NOT be disposed of by incineration.

PRECAUTIONS

WARNING



Lithium

A Lithium battery (or a Lithium battery contained within an IC) is used in this equipment.

As Lithium is a toxic substance, the battery should in no circumstances be crushed, incinerated or disposed of in normal waste.

Do not attempt to recharge this type of battery. Do not short circuit or force discharge since this might cause the battery to vent, overheat or explode.

WARNING



Heavy equipment

The weight of the 6800 Series exceeds the 18 kg (40 lb) guideline for manual handling by a single person. To avoid the risk of injury, an assessment should be carried out prior to handling which takes account of the load, workplace environment and individual capability, in accordance with European Directive 90/269/EEC and associated National Regulations.

WARNING



Tilt facility

When the equipment is in the tilt position, it is advisable, for stability reasons, not to stack other equipment on top of it.

CAUTION



Static sensitive components

This equipment contains static sensitive components which may be damaged by handling - refer to the Maintenance part of the Service Manual for handling precautions.

CAUTION



Precision connector

The precision microwave connectors fitted to this equipment may be damaged by mating with a non-precision type. Damage to the connector may also occur if the connector interface parameters are not within specification. The connector should be checked with the appropriate gauging tool.

CAUTION

Suitability for use

This equipment has been designed and manufactured by Aeroflex to perform measurements on RF and microwave components and systems.

If the equipment is not used in a manner specified by Aeroflex, the protection provided by the equipment may be impaired.

Aeroflex has no control over the use of this equipment and cannot be held responsible for events arising from its use other than for its intended purpose.

Précautions

WARNING

CAUTION

Note

Les termes suivants ont, dans ce manuel, des significations particulières:

WARNING

contient des informations pour éviter toute blessure au personnel.

CAUTION



contient des informations pour éviter les dommages aux équipements.

Note

contient d'importantes informations d'ordre général.

Symboles signalant un risque

La signification des symboles de danger apparaissant sur l'équipement et dans la documentation est la suivante:

Symbole	Nature du risque
	Reportez-vous au manuel d'utilisation quand ce symbole apparaît sur l'instrument. Familiarisez-vous avec la nature du danger et la conduite à tenir.
	Tension dangereuse
	Danger produits toxiques

Conditions générales d'utilisation

Ce produit a été conçu et testé pour être conforme aux exigences des normes CEI/EN61010-1 "Règles de sécurité pour appareils électriques de mesurage, de régulation et de laboratoire", pour des équipements Classe I portables et pour une utilisation dans un environnement de pollution de niveau 2. Cet équipement est conçu pour fonctionner à partir d'une alimentation de catégorie II. Cet équipement doit être protégé de l'introduction de liquides ainsi que des précipitations d'eau, de neige, etc... Lorsqu'on transporte cet équipement d'un environnement chaud vers un environnement froid, il est important de laisser l'équipement se stabiliser en température avant de le connecter à une alimentation afin d'éviter toute formation de condensation. L'appareil doit être utilisé uniquement dans le cadre des conditions d'environnement spécifiées au chapitre 1 'Performance data' du manuel d'utilisation, toute autre utilisation peut endommager les systèmes de protection.

Ce produit n'est pas garanti pour fonctionner dans des atmosphères dangereuses ou pour un usage médical. Si l'équipement doit être utilisé pour des applications en relation avec la sécurité, par exemple des applications militaires ou aéronautiques, la compatibilité du produit doit être établie et approuvée par une personne compétente.

WARNING



Sécurité électrique (tension d'alimentation alternative)

Cet appareil est protégé conformément à la norme CEI de sécurité Classe 1, c'est-à-dire que sa prise secteur comporte un fil de protection à la terre. Pour maintenir cette protection, le câble d'alimentation doit toujours être branché à la source d'alimentation par l'intermédiaire d'une prise comportant une borne de terre.

Notez que les filtres d'alimentation contiennent des condensateurs qui peuvent encore être chargés lorsque l'appareil est débranché. Bien que l'énergie contenue soit conforme aux exigences de sécurité, il est possible de ressentir un léger choc si l'on touche les bornes sitôt après débranchement.

Ne démontez pas le capot de l'instrument, car ceci peut provoquer des blessures. Il n'y a pas de pièces remplaçables par l'utilisateur à l'intérieur.

Faites effectuer toute réparation par du personnel qualifié. Contacter un des Centres de Maintenance Internationaux dans la liste jointe à la fin du manuel.

Fusibles

Notez qu'il y a deux fusibles, l'un pour la phase et l'autre pour le neutre du câble d'alimentation. Si un seul fusible est coupé, certaines parties de l'appareil peuvent rester au potentiel d'alimentation.

WARNING



Risque lié au feu

Lors du remplacement des fusibles vérifiez l'exactitude de leur type et de leur valeur. Si le câble d'alimentation comporte une prise avec fusible intégré, assurez vous que sa valeur est compatible avec les besoins en courant de l'appareil. Pour la consommation, reportez vous à chapitre 1 du manuel d'utilisation.

WARNING



Danger produits toxiques

Certains composants utilisés dans cet appareil peuvent contenir des résines et d'autres matières qui dégagent des fumées toxiques lors de leur incinération. Les précautions d'usages doivent donc être prises lorsqu'on se débarrasse de ce type de composant.

WARNING



Bronze au béryllium

Dans cet équipement, certaines pièces mécaniques sont à base de bronze au béryllium. Il s'agit d'un alliage dans lequel le pourcentage de béryllium ne dépasse pas 5%. Il ne présente aucun danger en utilisation normale.

Toutefois, cet alliage ne doit pas être travaillé, soudé ou soumis à un processus qui implique l'utilisation d'une source de chaleur.

En cas de destruction, il sera entreposé dans un container spécial. IL ne devra pas être détruit par incinération

WARNING



Lithium

Une pile au Lithium ou un CI contenant une pile au Lithium est utilisé dans cet équipement. Le Lithium étant une substance toxique, il ne faut en aucun cas l'écraser, l'incinérer ou le jeter avec des déchets normaux.

N'essayez pas de recharger ce type de pile. Ne court-circuitiez pas ou ne forcez pas la décharge de la pile car cela pourrait causer une fuite, une surchauffe ou une explosion.

PRECAUTIONS

WARNING



Equipement lourd

Le poids des appareils du 6800 Serie est supérieur à la limite de 18 kg (40 lb), fixée pour le transport par une seule personne. Afin d'éviter tout risque de blessure, il est nécessaire de faire, avant le transport, une évaluation de la charge, des contraintes de l'environnement et des capacités de l'individu, en conformité avec la Directive Européenne 90/269/EEC ainsi que les recommandations Nationales concernées.

WARNING



Position inclinée

Lorsque l'appareil est dans une position inclinée, il est recommandé, pour des raisons de stabilité, de ne pas y empiler d'autres appareils.

CAUTION

Utilisation

Cet équipement a été conçu et fabriqué par Aeroflex pour effectuer des mesures sur des composants et des systèmes RF et hyperfréquences

La protection de l'équipement peut être altérée s'il n'est pas utilisé dans les conditions spécifiées par Aeroflex.

Aeroflex n'a aucun contrôle sur l'usage de l'instrument, et ne pourra être tenu pour responsable en cas d'événement survenant suite à une utilisation différente de celle prévue.

Vorsichtsmaßnahmen

WARNING

CAUTION

Note

Diese Hinweise haben eine bestimmte Bedeutung in diesem Handbuch:

WARNING

dienen zur Vermeidung von Verletzungsrisiken.

CAUTION



dienen dem Schutz der Geräte.

Note

enthalten wichtige Informationen.

Gefahrensymbole

Die Bedeutung der Gefahrensymbole auf den Geräten und in der Dokumentation ist wie folgt:

Symbol	Gefahrenart
	Beziehen Sie sich auf die Bedienungsanleitung wenn das Messgerät mit diesem Symbol markiert ist. Machen Sie sich mit der Art der Gefahr und den Aktionen die getroffen werden müssen bekannt.
	Gefährliche Spannung
	Warnung vor giftigen Substanzen

Allgemeine Hinweise zur Verwendung

Dieses Produkt wurde entsprechend den Anforderungen von IEC/EN61010-1 "Sicherheitsanforderungen für elektrische Ausrüstung für Meßaufgaben, Steuerung und Laborbedarf", Klasse I transportabel zur Verwendung in einer Grad 2 verunreinigten Umgebung, entwickelt und getestet. Dieses Gerät ist für Netzversorgung Klasse II zugelassen.

Das Gerät sollte vor dem Eindringen von Flüssigkeiten sowie vor Regen, Schnee etc. geschützt werden. Bei Standortänderung von kalter in wärmere Umgebung sollte das Gerät wegen der Kondensation erst nach Anpassung an die wärmere Umgebung mit dem Netz verbunden werden. Das Gerät darf nur in Umgebungsbedingungen wie im Kapitel 1 'Lesitungsdaten (Performance data)' der Bedienungsanleitung beschrieben, betrieben werden; ansonsten wird der vom Gerät vorgesehene Schutz des Anwenders beeinträchtigt.

Dieses Produkt ist nicht für den Einsatz in gefährlicher Umgebung (z.B. Ex-Bereich) und für medizinische Anwendungen geprüft. Sollte das Gerät für den Einsatz in sicherheitsrelevanten Anwendungen wie z.B. im Flugverkehr oder bei militärischen Anwendungen vorgesehen sein, so ist dieser von einer für diesen Bereich zuständigen Person zu beurteilen und genehmigen.

WARNING



Elektrische Schläge (Wechselspannungsversorgung)

Das Gerät entspricht IEC Sicherheitsklasse 1 mit einem Schutzleiter nach Erde. Das Netzkabel muß stets an eine Steckdose mit Erdkontakt angeschlossen werden.

Filterkondensatoren in der internen Spannungsversorgung können auch nach Unterbrechung der Spannungszuführung noch geladen sein. Obwohl die darin gespeicherte Energie innerhalb der Sicherheitsmargen liegt, kann ein leichter Spannungsschlag bei Berührung kurz nach der Unterbrechung erfolgen.

Öffnen Sie niemals das Gehäuse der Geräte das dies zu ernsthaften Verletzungen führen kann. Es gibt keine vom Anwender austauschbare Teile in diesem Gerät.

Lassen Sie alle Reparaturen durch qualifiziertes Personal durchführen. Eine Liste der Servicestellen finden Sie auf der Rückseite des Handbuches.

Sicherungen

Es ist zu beachten, daß es Sicherungen in beiden (spannungsführenden und neutralen) Zuleitungen gibt. Wenn nur eine von diesen Sicherungen schmilzt, so bleiben einige Geräteteile immer noch auf Spannungspotential.

WARNING



Feuergefahr

Es dürfen nur Ersatzsicherungen vom gleichen Typ mit den korrekten Spezifikationen entsprechend der Stromaufnahme des Gerätes verwendet werden. Siehe hierzu nach Kapitel 1.

WARNING



Warnung vor giftigen Substanzen

In einigen Bauelementen dieses Geräts können Epoxyharze oder andere Materialien enthalten sein, die im Brandfall giftige Gase erzeugen. Bei der Entsorgung müssen deshalb entsprechende Vorsichtsmaßnahmen getroffen werden.

WARNING



Beryllium Kupfer

In diesem Gerät sind einige mechanische Komponenten aus Beryllium Kupfer gefertigt. Dies ist eine Verbindung welche aus einem Berylliumanteil von ca. 5 % besteht. Bei normaler Verwendung besteht kein Gesundheitsrisiko.

Das Metall darf nicht bearbeitet, geschweißt oder sonstiger Wärmebehandlung ausgesetzt werden.

Es muß als Sondermüll entsorgt werden.

Es darf nicht durch Verbrennung entsorgt werden.

WARNING



Lithium

Eine Lithium Batterie oder eine Lithium Batterie innerhalb eines IC ist in diesem Gerät eingebaut.

Da Lithium ein giftiges Material ist, sollte es als Sondermüll entsorgt werden.

Diese Batterie darf auf keinen Fall geladen werden. Nicht kurzschließen, da sie dabei überhitzt werden und explodieren kann.

WARNING



Schweres Gerät

Das Gewicht der 6800 Series Geräte liegt über der 18 kg (40 lb) Grenze für Transport durch eine einzelne Person. Zur Vermeidung von Verletzungen sollten vor einem Transport die Arbeitsumgebung und die persönlichen Möglichkeiten im Verhältnis zur Last abgewogen werden, wie in der EU-Regelung 90/269/EEC und nationalen Normen beschrieben.

WARNING



Schrägstellung

Bei Schrägstellung des Geräts sollten aus Stabilitätsgründen keine anderen Geräte darauf gestellt werden.

CAUTION

Eignung für Gebrauch

Dieses Gerät wurde von Aeroflex entwickelt und hergestellt um Messungen an HF- und Mikrowellenkomponenten und -Systemen durchzuführen

Sollte das Gerät nicht auf die von Aeroflex vorgesehene Art und Weise verwendet werden, kann die Schutzfunktion des Gerätes beeinträchtigt werden.

Aeroflex hat keinen Einfluß auf die Art der Verwendung und übernimmt keinerlei Verantwortung bei unsachgemässer Handhabung.

Precauzioni

WARNING

CAUTION

Note

Questi termini vengono utilizzati in questo manuale con significati specifici:

WARNING

riportano informazioni atte ad evitare possibili pericoli alla persona.

CAUTION



riportano informazioni per evitare possibili pericoli all'apparecchiatura.

Note

riportano importanti informazioni di carattere generale.

Simboli di pericolo

Il significato del simbolo di pericolo riportato sugli strumenti e nella documentazione è il seguente:

Simbolo	Tipo di pericolo
	Fare riferimento al manuale operativo quando questo simbolo è riportato sullo strumento. Rendervi conto della natura del pericolo e delle precauzioni che dovrete prendere.
	Tensione pericolosa
	Pericolo sostanze tossiche

Condizioni generali d'uso

Questo prodotto è stato progettato e collaudato per rispondere ai requisiti della direttiva IEC/EN61010-1 'Safety requirements for electrical equipment for measurement, control and laboratory use' per apparati di classe I portatili e per l'uso in un ambiente inquinato di grado 2. L'apparato è stato progettato per essere alimentato da un alimentatore di categoria II.

Lo strumento deve essere protetto dal possibile ingresso di liquidi quali, ad es., acqua, pioggia, neve, ecc. Qualora lo strumento venga portato da un ambiente freddo ad uno caldo, è importante lasciare che la temperatura all'interno dello strumento si stabilizzi prima di alimentarlo per evitare formazione di condense. Lo strumento deve essere utilizzato esclusivamente nelle condizioni ambientali descritte nel capitolo 1 'Performance data' del manuale operativo, in caso contrario le protezioni previste nello strumento potrebbero risultare non sufficienti.

Questo prodotto non è stato approvato per essere usato in ambienti pericolosi o applicazioni medicali. Se lo strumento deve essere usato per applicazioni particolari collegate alla sicurezza (per esempio applicazioni militari o avioniche), occorre che una persona o un istituto competente ne certifichi l'uso.

WARNING



Pericoli da elettricità (alimentazione c.a.)

Quest 'apparato è provvisto del collegamento di protezione di terra e rispetta le norme di sicurezza IEC, classe 1. Per mantenere questa protezione è necessario che il cavo, la spina e la presa d'alimentazione siano tutti provvisti di terra.

Il circuito d'alimentazione contiene dei filtri i cui condensatori possono restare carichi anche dopo aver rimosso l'alimentazione. Sebbene l'energia immagazzinata è entro i limiti di sicurezza, purtuttavia una leggera scossa può essere avvertita toccando i capi della spina subito dopo averla rimossa.

Non rimuovete mai le coperture perché così potreste provocare danni a voi stessi. Non vi sono all'interno parti di interesse all'utilizzatore.

Tutte gli interventi sono di competenza del personale qualificato. Vedi elenco internazionale dei Centri di Assistenza in fondo al manuale.

Fusibili

Notare che entrambi i capi del cavo d'alimentazione sono provvisti di fusibili. In caso di rottura di uno solo dei due fusibili, alcune parti dello strumento potrebbero restare sotto tensione.

WARNING



Pericolo d'incendio

Assicurarsi che, in caso di sostituzione, vengano utilizzati solo fusibili della portata e del tipo prescritti.

Se viene usata una spina con fusibili, assicurarsi che questi siano di portata adeguata ai requisiti di alimentazione richiesti dallo strumento. Tali requisiti sono riportati nello capitolo 1.

WARNING



Pericolo sostanze tossiche

Alcuni dei componenti usati in questo strumento possono contenere resine o altri materiali che, se bruciati, possono emettere fumi tossici. Prendere quindi le opportune precauzioni nell'uso di tali parti.

WARNING



Rame berillio

Alcuni componenti meccanici in questo strumento sono realizzati in rame berillio. Si tratta di una lega con contenuto di berillio di circa il 5%, che non presenta alcun rischio in usi normali.

Questo materiale non deve essere lavorato, saldato o subire qualsiasi processo che coinvolge alte temperature.

Deve essere eliminato come "rifiuto speciale". Non deve essere eliminato tramite "inceneritore".

WARNING



Litio

Quest 'apparato incorpora una batteria al litio o un circuito integrato contenente una batteria al litio.

Poiché il litio è una sostanza tossica, la batteria non deve essere mai né rotta, né incenerita, né gettata tra i normali rifiuti.

Questo tipo di batteria non può essere sottoposto né a ricarica né a corto-circuito o scarica forzata. Queste azioni possono provocare surriscaldamento, fuoriuscita di gas o esplosione della batteria.

PRECAUTIONS

WARNING



Strumento pesante

Il peso degli strumenti serie 6800 supera i 18 kg (40 lb) raccomandati come limite per il trasporto manuale da parte di singola persona. Per evitare rischi di danni fisici è bene quindi considerare il carico complessivo, le condizioni del trasporto e le capacità individuali in accordo con la direttiva comunitaria 90/269/EEC e con eventuali regolamenti locali.

WARNING



Posizionamento inclinato

Quando lo strumento è in posizione inclinata è raccomandato, per motivi di stabilità, non sovrapporre altri strumenti.

CAUTION

Caratteristiche d'uso

Questo strumento è stato progettato e prodotto da Aeroflex eseguire misure su componenti o sistemi RF e microonde

Se lo strumento non è utilizzato nel modo specificato da Aeroflex, le protezioni previste sullo strumento potrebbero risultare inefficaci.

Aeroflex non può avere il controllo sull'uso di questo strumento e non può essere ritenuta responsabile per eventi risultanti da un uso diverso dallo scopo prefisso.

Precauciones

WARNING

CAUTION

Note

Estos términos tienen significados específicos en este manual:

WARNING

contienen información referente a prevención de daños personales.

CAUTION



contienen información referente a prevención de daños en equipos.

Note

contienen información general importante.

Símbolos de peligro

El significado de los símbolos de peligro en el equipo y en la documentación es el siguiente:

Símbolo	Naturaleza del peligro
	Vea el manual de funcionamiento cuando este símbolo aparezca en el instrumento. Familiarícese con la naturaleza del riesgo y con las acciones que deban de tomarse.
	Voltaje peligroso
	Aviso de toxicidad

Condiciones generales de uso

Este producto ha sido diseñado y probado para cumplir los requerimientos de la normativa IEC/EN61010-1 “Requerimientos de la normativa para equipos eléctricos de medida, control y uso en laboratorio”, para equipos clase I portátiles y para uso en un ambiente con un grado de contaminación 2. El equipo ha sido diseñado para funcionar sobre una instalación de alimentación de categorías II.

Debe protegerse el equipo de la entrada de líquidos y precipitaciones como nieve, lluvia, etc. Cuando se traslada el equipo de entorno frío a un entorno caliente, es importante aguardar la estabilización del equipo para evitar la condensación. Solamente debe utilizarse el equipo bajo las condiciones ambientales especificadas en el capítulo 1 “Especificaciones” o “Performance data” del Manual de Instrucciones, en caso contrario la propia protección del equipo puede resultar dañada.

Este producto no ha sido aprobado para su utilización en entornos peligrosos o en aplicaciones médicas. Si se va a utilizar el equipo en una aplicación con implicaciones en cuanto a seguridad, como por ejemplo aplicaciones de aviónica o militares, es preciso que un experto competente en materia de seguridad apruebe su uso.

WARNING

 **Nivel peligroso de electricidad (tensión de red)**

Este equipo cumple las normas IEC Seguridad Clase 1, lo que significa que va provisto de un cable de protección de masa. Para mantener esta protección, el cable de alimentación de red debe de conectarse siempre a una clavija con terminal de masa.

Tenga en cuenta que el filtro de red contiene condensadores que pueden almacenar carga una vez desconectado el equipo. Aunque la energía almacenada está dentro de los requisitos de seguridad, pudiera sentirse una ligera descarga al tocar la clavija de alimentación inmediatamente después de su desconexión de red.

No retire las cubiertas del chasis del instrumento, ya que pudiera resultar dañado personalmente. No existen partes que puedan ser reparadas en su interior.

Deje todas las tareas relativas a reparación a un servicio técnico cualificado. Vea la lista de Centros de Servicios Internacionales en la parte trasera del manual.

Fusibles

Se hace notar que el Equipo está dotado de fusibles tanto en el activo como el neutro de alimentación. Si sólo uno de estos fusibles fundiera, existen partes del equipo que pudieran permanecer a tensión de red.

WARNING

 **Peligro de incendio**

Asegúrese de utilizar sólo fusibles del tipo y valores especificados como repuesto.

Si se utiliza una clavija con fusible incorporado, asegúrese de que los valores del fusible corresponden a los requeridos por el equipo. Consulte el Capítulo 1 para comprobar los requisitos de alimentación.

WARNING

 **Aviso de toxicidad**

Alguno de los componentes utilizados en este equipo pudieran incluir resinas u otro tipo de materiales que al arder produjeran sustancias tóxicas, Por tanto, tome las debidas precauciones en la manipulación de esas piezas.

WARNING

 **Berilio-cobre**

Algunos componentes mecánicos contenidos en este instrumento incorporan berilio-cobre en su proceso de fabricación. Se trata de una aleación con un contenido aproximado de berilio del 5%, lo que no representa ningún riesgo durante su uso normal.

El material no debe ser manipulado, soldado, ni sometido a ningún proceso que implique la aplicación de calor.

Para su eliminación debe tratarse como un "residuo especial". El material NO DEBE eliminarse mediante incineración.

WARNING



Litio

En este equipo se utiliza una batería de litio (o contenida dentro de un CI).

Dada que el litio es una sustancia tóxica las baterías de este material no deben ser aplastadas, quemadas o arrojadas junto a basuras ordinarias.

No trate de recargar este tipo de baterías. No las cortocircuite o fuerce su descarga ya que puede dar lugar a que la esta emita gases, se recaliente o explote.

WARNING



Instrumento pesado

El peso de los equipos Serie 6800 es superior a la recomendación de 18 Kg (40 lb), lo que debe tenerse en cuenta. si va ser transportado manualmente por una sola persona. Para evitar el riesgo de lesiones, antes de mover el equipo deberá evaluar la carga, el entorno de trabajo y la propia capacidad, de acuerdo con la Directiva Europea 90/269/EEC y el Reglamento Nacional Asociado.

WARNING



Tener en cuenta con el equipo inclinado

Si utiliza el equipo en posición inclinada, se recomienda, por razones de estabilidad, no apilar otros equipos encima de él.

CAUTION

Idoneidad de uso

Este equipo ha sido diseñado y fabricado por Aeroflex para realizar medidas en RF y microondas en componentes y sistemas

Si el equipo fuese utilizado de forma diferente a la especificada por Aeroflex, la protección ofrecida por el equipo pudiera quedar reducida.

Aeroflex no tiene control sobre el uso de este equipo y no puede, por tanto, exigirsele responsabilidades derivadas de una utilización distinta de aquellas para las que ha sido diseñado.

Chapter 1

GENERAL INFORMATION

Contents

Purpose and features of equipment.....	1-1
Introduction	1-1
Main features	1-2
Synthesized source	1-2
Scalar analyzer	1-2
Fault location.....	1-3
Spectrum analyzer	1-3
Other features	1-3
User interface	1-4
Display	1-4
Remote operation	1-4
Results logging and outputting.....	1-4
Applications	1-5
User calibrations.....	1-5
Performance data - 6820A series.....	1-6
Versions, options and accessories - 6820A series	1-15
Performance data - 6840A series.....	1-19
Versions, options and accessories - 6840A series	1-30

Purpose and features of equipment

Introduction

The 6840A series of instruments are portable RF and microwave measurement instruments which integrate a synthesized frequency source, 3-input scalar analyzer and spectrum analyzer into a single case. The 6820A series are scalar analyzers only and do not contain a spectrum analyzer.

6821A	RF Scalar Analyzer	1 MHz to 3 GHz scalar analyzer
6822A	Microwave Scalar Analyzer	10 MHz to 8.4 GHz scalar analyzer
6823A	Microwave Scalar Analyzer	10 MHz to 20 GHz scalar analyzer
6824A	Microwave Scalar Analyzer	10 MHz to 24 GHz scalar analyzer
6825A	Microwave Scalar Analyzer	10 MHz to 46 GHz scalar analyzer
6825AR	Microwave Scalar Analyzer	10 MHz to 40 GHz scalar analyzer
6841A	RF System Analyzer	1 MHz to 3 GHz scalar analyzer with 4.2 GHz spectrum analyzer
6842A	Microwave System Analyzer	10 MHz to 8.4 GHz scalar analyzer with 20 GHz spectrum analyzer
6843A	Microwave System Analyzer	10 MHz to 20 GHz scalar analyzer with 20 GHz spectrum analyzer
6844A	Microwave System Analyzer	10 MHz to 24 GHz scalar analyzer with 24 GHz spectrum analyzer
6845A	Microwave System Analyzer	10 MHz to 46 GHz scalar analyzer with 46 GHz spectrum analyzer
6845AR	Microwave System Analyzer	10 MHz to 40 GHz scalar analyzer with 40 GHz spectrum analyzer
6846A	Microwave System Analyzer	10 MHz to 8.4 GHz scalar analyzer with 24 GHz spectrum analyser
6847A	Microwave System Analyzer	10 MHz to 20 GHz scalar analyser with 26.5 GHz spectrum analyser
6848A	RF System Analyzer	1 MHz to 3 GHz scalar analyser with 20 GHz spectrum analyzer

Integrating several functions into one unit provides convenience of operation and enables a number of specialised measurements to be made with ease, for example during the design and manufacture of microwave sub-systems and modules. The small size and ease of use of the 6800A make it ideal for use in a field environment, such as during installation and maintenance of microwave systems. Typical applications for the 6800A are:

- Measurement of insertion loss and return loss of passive components.
- Gain, gain compression, frequency response and return loss of active components.
- Measurements on mixers, oscillators, up-converters and down-converters.
- The spectrum analyzer enables detailed signal analysis to be performed, such as measurements of harmonic and spurious signals and intermodulation products. Facilities are also available for displaying FM demodulated signals
- Location of faults in waveguide and coaxial transmission lines is possible using the real-time fault location facility. This utilises advanced processing techniques to improve distance and magnitude accuracy and reduce measurement uncertainty.
- Group delay measurements on communications links and signal processing devices (for 6840A series instruments with the Group Delay option fitted).

Main features

Synthesized source

The 6800A uses a fully synthesized frequency source for precision sweeps with high resolution and frequency stability and low phase noise. The source also provides an accurate CW output and can be used as a tracking generator during spectrum analyzer measurements. A power sweep mode is provided for gain compression testing. Power level is settable over a 15 dB range (20 dB for frequencies <3 GHz, with a maximum guaranteed levelled power of +5 dBm (+10 dBm for frequencies <3 GHz).

The source can be frequency modulated in CW mode using a suitable external modulating signal. An internal modulating signal is also available if the Group Delay option (6840A Series only) or Internal FM generator option is fitted. If the Pulse Modulator option is fitted (6820A Series only), external pulse modulation is possible. If both Internal FM generator and Pulse Modulator options are fitted, internal and external FM and pulse modulation are possible.

Optional step attenuators are available to set low output powers for small signal applications.

Scalar analyzer

The three input scalar analyzer can be used for network characterisation of components and systems and has typically a 75 dB dynamic range. Two display channels are provided, each with its own graticule and each capable of displaying up to two swept measurements (insertion and return loss for example). The channels may be coupled together for the simultaneous update of up to four traces, or they can be uncoupled so that each channel can display a different frequency range, allowing simultaneous display of pass-band and stop-band characteristics, for example.

A wide range of scalar detectors is available (6230A/L Series). Each detector contains an EEPROM device which is used to store individual detector linearity and flatness (frequency response) correction data. This results in accurate power measurements over a wide dynamic range. High-directivity autotesters are available for return loss measurements.

In addition to scalar measurements with broadband diode detectors, it is also possible (with 6840A series) to make frequency selective scalar measurements with a tuned input, i.e. using the spectrum analyzer receiver. A tuned input gives improved dynamic range, enabling insertion loss measurements of greater than 80 dB to be achieved. This facility is useful, for example, when making insertion loss measurements on filters. The source can be set to any frequency offset or multiple of the receiver tuned input, simplifying measurements on frequency translation devices such as mixers, up-converters and down-converters.

The phase linearity of many devices is specified in terms of group (or envelope) delay. This is an important measurement in telecommunications components and systems where phase distortion is critical.

Facilities are also provided for calibrating the measurement system and for storing the calibration data for use in other measurements.

Fault location

Location of faults in transmission lines can be accomplished using the fast fault location capability of the 6800A together with the 6240 Series Fault Locators. Measurements can be made on lines up to 25 km, depending on cable or waveguide loss, with a distance accuracy of 3 mm or 0.1% of range. Transmission line parameters can be set directly, or from transmission line database records supplied on removable storage.

Spectrum analyzer

The 6840A variants contain a spectrum analyzer which can operate either as a normal spectrum analyzer (plotting amplitude against frequency), or in demodulation mode, where the display is the demodulated waveform plotted as FM deviation against time. Demodulated signals may be monitored on the internal loudspeaker. An integral frequency counter enables accurate frequency measurements to be made.

The parameters affecting the resolution bandwidth filter, video filter, sweep speed and input attenuation are coupled, and are automatically set for optimum sweep speed and dynamic range. For specific applications one or more parameters can be uncoupled and manually set. An auto tune facility enables fast signal capture by automatically sweeping at full span and then displaying the largest signal at the centre of the screen with a suitable span.

The source can be used as a tracking generator during spectrum analyzer measurements, so that a swept signal is output whose frequency precisely tracks the spectrum analyzer tuning. The tracking generator can be used to provide the sweeping signal when measuring the frequency response of devices. Offset and scaling can also be applied in order that measurements can be made on components or subsystems that provide frequency translation.

The spectrum analyzer receiver can also be used in place of a scalar detector in order to give frequency selective scalar analyzer measurements.

Other features

A comprehensive range of marker functions enable scalar, fault location and spectrum analyzer measurements to be examined in detail, and allow various types of measurement to be performed. Up to 8 intelligent markers are available, via menus which are structured to provide the tools that are most useful in each of the measurement modes

In scalar mode markers can be used to automatically calculate peak to peak ripple, n dB bandwidth, search for a specified response value, and find maximum and minimum signal levels. This simplifies device characterisation and reduces test time.

For fault location measurements the next peak left/right feature is used to identify the position and magnitude of each of the discontinuities along the transmission line. The find maximum function can be used to quickly locate the maximum point on the trace, i.e. the location of the largest discontinuity on the line.

In spectrum mode the markers can be used to identify the maximum signal, locate other peaks on the display, search for a specified response value, and measure signals relative to the carrier. An identify peaks feature instantly places markers on the 8 highest signals, which is ideal for spurious signal identification. A marker table displayed below the traces shows the values of all 8 markers dynamically. For frequencies less than 200 MHz a counter is available which enables the frequency of any spectral line on the display to be measured by moving the active marker to the frequency of interest.

Upper and lower complex limit lines can be defined, against which the trace can be compared to verify that measurements are within specification.

Non-volatile stores are provided for the storage of measurements, calibration data, instrument settings, limit specifications, transmission line database records and applications.

User interface

The 6800A firmware controls the functions of the synthesized source, scalar analyzer and spectrum analyzer. Operator interaction with the system is performed using a liquid crystal display (LCD) and the front panel controls. Menus, instructions, error messages and help text are displayed on the LCD, and menu selection is accomplished using a set of eight soft keys adjacent to the display.

The measurement to be performed is defined using a simple menu system. All commonly accessed functions are no more than one level down in the menu tree structure so that the instrument operation is easily learnt.

Non-volatile storage is provided for instrument settings and measurement traces for future use. Stores are also provided for path calibration data, limit checking specifications, application programs and transmission line database records.

As an alternative to using the front panel to control the 6800A functions, an external IBM compatible keyboard can be connected via a standard keyboard interface. International support for keyboards is provided.

Display

The display is a TFT colour LCD with a resolution of 640×480 pixels. Up to 4 measurements on 2 channels can be displayed simultaneously. Both channels are fully independent which means that it is possible to make and display scalar and spectrum measurements simultaneously. Alternatively 2 spectrum channels can be configured with a wide and narrow frequency sweep. This could be used, for example, to scan a frequency spectrum for interfering signals whilst simultaneously displaying the known, wanted carrier.

A rear panel connector is available for connecting an external standard VGA colour monitor.

Remote operation

Remote control commands are provided enabling full control of the system via the GPIB interface. The GPIB complies with IEEE 488.2 and follows the SCPI convention (Standard Commands for Programmable Instrumentation). The commands also enable the instrument to be controlled via the RS-232 (serial) interface. This aspect of instrument operation is covered in the Remote Operating Manual.

Results logging and outputting

Measurement results can be saved in a variety of ways. The 6800A has internal non-volatile memory that can be used for storing traces, instrument settings and calibrations. To store results separately from the instrument there are two USB ports. Traces can be saved onto removable storage and then imported into a spreadsheet for viewing. Alternatively, the optional MIPlot software package can be used to capture the measurement data either via the GPIB or from a saved trace on removable storage. This data can then be re-processed, such as changing colours, or adding limit lines, markers and text. It can then be embedded into a document or used in a slide presentation, for example.

Measurement results, either current or stored, may be output to a suitable printer via a USB port or the parallel (Centronics) interface. The operator has extensive control of hard copy formatting, with facilities for generating titles and other annotation. The printer can also be used to obtain a hard copy from a previously saved print file. The hard copy output is buffered so that further measurements can be made while printing is in progress. Hard copy can also be created for the instrument build state, limit checking specifications and instrument settings stores.

Applications

The 6800A allows user-defined routines to be written that can be run on the instrument. These application programs can be used to automate measurement procedures, or to provide step-by-step guidance when making measurements. The application program can guide the operator through the measurement via prompts and diagrams, and it is not necessary to be familiar with the theory of the measurement or with the instrument's operation or menu structure.

User calibrations

At temperatures outside the range +20°C to +30°C, the performance of the instruments can be optimized by performing user calibrations. This facility is available via the [UTILITY] menu and selecting: [Service] [Instrument Calibrations]. There are menus covering both the RF source and Spectrum Analyzer calibrations. In both menus, a facility exists to perform a "Frequency Calibration" and this should be utilized when the "Unloc" indicator appears at the top of the screen.

If performing the frequency calibration does not clear the "Unloc" indicator, then consult your local service centre.

Performance data - 6820A series

Source

Functionality	Synthesized CW. Synthesized sweeper for use with scalar analyzer. CW Power sweep. External modulation Optional internal modulation, FM + pulse driver (Option 023) Optional internal pulse modulator (Option 025)
Frequency Range	
6821A	1 MHz to 3 GHz
6822A	10 MHz to 8.4 GHz
6823A	10 MHz to 20 GHz
6824A	10 MHz to 24 GHz
6825A	10 MHz to 46 GHz
6825AR	10 MHz to 40 GHz
Resolution (Settable)	
to 46 GHz	1 Hz
CW Accuracy	(Frequency Standard error x Frequency) ± 10 Hz
Swept Accuracy (Typical)	
300 µs Step Time	
1 MHz to 3 GHz	<20 kHz
3 GHz to 46 GHz	<200 kHz
1 ms Step Time	
1 MHz to 3 GHz	<1 kHz
3 GHz to 46 GHz	<10 kHz
10 ms Step Time	
1 MHz to 3 GHz	<100 Hz
3 GHz to 46 GHz	<1 kHz
Levelled Power Range	
6821/2/3/4A standard	
1 MHz to 3 GHz	-10 dBm to +10 dBm
3 GHz to 24 GHz	-10 dBm to +5 dBm
6825A & 6825AR	
10 MHz to 8 GHz	-10 dBm to +8 dBm +10 dBm typ
8 GHz to 20 GHz	-10 dBm to +5 dBm +7 dBm typ
20 GHz to 24 GHz	-10 dBm to +4 dBm +6 dBm typ
24 GHz to 40 GHz	-10 dBm to +0 dBm +3 dBm typ
40 GHz to 46 GHz	-10 dBm to +0 dBm typ*
	*excluding the effect of connector moding
6822/3/4A + option 030 (higher power)	
1 MHz to 24 GHz	-10 dBm to +10 dBm
6821A + option 010 (110 dB Step Attenuator)	
1 MHz to 3 GHz	-120 dBm to +8 dBm
6822/3A + option 011 (70 dB Step Attenuator)	
10 MHz to 3 GHz	-80 dBm to +8 dBm
3 GHz to 20 GHz	-80 dBm to +2 dBm
	+ option 030 (higher power)
3 GHz to 20 GHz	-80 dBm to +7 dBm

GENERAL INFORMATION

6822/3/4A + option 012 (90 dB Step Attenuator)	
10 MHz to 3 GHz	-100 dBm to +8 dBm
3 GHz to 24 GHz	-100 dBm to +2 dBm
+ option 030 (higher power)	
3 GHz to 24 GHz	-100 dBm to +7 dBm

6825A & 6825AR + option 013 (70 dB Step Attenuator)	
10 MHz to 8 GHz	-80 dBm to +6 dBm, +8 dBm typical
8 GHz to 20 GHz	-80 dBm to +2 dBm, +4 dBm typical
20 GHz to 24 GHz	-80 dBm to +1 dBm, +3 dBm typical
24 GHz to 40 GHz	-80 dBm to -3 dBm, 0 dBm typical

Notes:

- 1) For option 002 (Field Replaceable Connectors) guaranteed levelled output is reduced by 0.5 dB.
- 2) For Option 025 (internal pulse modulator) the guaranteed levelled output is reduced as the option specification.

Settable Power Resolution	0.01 dB
Power Sweep Range (from Maximum Levelled Power) without Attenuator	>20 dB (except when Option 025, internal pulse modulation, is fitted)
Internal Levelling Accuracy at 0 dBm (no options fitted, option 030)	
1 MHz to 3 GHz	± 0.7 dB
3 GHz to 24 GHz	± 1.0 dB
24 GHz to 40 GHz	± 1.5 dB
Levelled Power Accuracy (with Options 010, 012, 013)	
1 MHz to 3 GHz	< ±1 dB (± 0.3 dB or 2% of attenuator setting in dB, whichever is the greater)
3 GHz to 24 GHz	< ±1 dB (± 1 dB or 4% of attenuator setting in dB, whichever is the greater)
24 GHz to 40 GHz	< ±1.5 dB (± 1 dB or 4% of attenuator setting in dB, whichever is the greater)

GENERAL INFORMATION

Linearity (No Options Fitted, Option 030) over Levelled Power Range Relative to 0 dBm

1 MHz to 40 GHz < ±0.5 dB

Power Stability with Temperature (typical)

1 MHz to 40 GHz < 0.1 dB/°C

Harmonics and Sub-Harmonics over Levelled Power Range

Harmonics

<70 MHz	< -25 dBc
70 MHz to 3 GHz	< -55 dBc
3 GHz to 24 GHz	< -50 dBc
24 GHz to 40 GHz	< -20 dBc

Spurious Signals (Typical)

For carrier frequencies <375 MHz

30 kHz to 150 kHz offset	< -50 dBc
>150 kHz offset	< -55 dBc

For carrier frequencies >375 MHz

30 kHz to 150 kHz offset	< -50 dBc
>150 kHz offset	< -60 dBc

Phase Noise in dBc/Hz in CW mode

CW Frequency	Frequency offset		
	1 kHz	10 kHz	100 kHz
0.25 GHz	-86	-95	-108
0.5 GHz	-98	-112	-134
1 GHz	-92	-106	-128
2 GHz	-86	-100	-122
4 GHz	-80	-92	-100
10 GHz	-72	-84	-90
20 GHz	-66	-78	-82
24 GHz	-64	-76	-80
40 GHz	-63	-75	-79

Source Match (Typical)

1 MHz to 3 GHz	15 dB
3 GHz to 20 GHz	10 dB
20 GHz to 40 GHz	8 dB

Output Connector

6821/2/3	Precision N type, female
6824	Precision 3.5 mm, female
6825	Precision 2.92 mm female
	Or optional field-replaceable connectors

GENERAL INFORMATION

External Frequency Modulation

Peak deviation (1 V peak output)

10 MHz - 375 MHz	1 kHz to 5 MHz
375 MHz - 750 MHz	250 Hz to 1.25 MHz
750 MHz - 1.5 GHz	500 Hz to 2.5 MHz
1.5 GHz - 3 GHz	1 kHz to 5 MHz
3 GHz - 46 GHz	20 kHz to 1 MHz

Accuracy (1 kHz modulating frequency)

20 - 400 kHz deviation	$\pm 3\%$ of indication ± 1 Hz excluding residual FM
-3 dB bandwidth, AC coupled mode	
10 MHz - 3 GHz	< 100 Hz to > 1 MHz typical
3 GHz - 46 GHz	< 100 Hz to > 500 kHz typical
-3 dB bandwidth, DC coupled mode	
10 MHz - 3 GHz	< DC to > 1 MHz typical
3 GHz - 46 GHz	< DC to > 500 kHz typical

Frequency Modulation Option 023

Modulation signal Sinewave, 0.1 Hz to 500 kHz
Resolution 0.1 Hz

Other specifications as for External Frequency Modulation except:

Accuracy (1 kHz modulating frequency)

20 - 400 kHz deviation $\pm 5\%$ of indication ± 1 Hz excluding residual FM

Pulse Generator Source

Modes	Single pulse, pulse pattern
Pulse Pattern	Pulse patterns comprising up to 256 pulse width/PRI pairs can be set up, stored and recalled
Trigger Modes	External, internal continuous
Pulse Widths (PW)	120 ns to >1 s
Resolution	120 ns
Pulse Period (PRI)	240 ns to 7 s (PRF <1 Hz to 4.16 MHz)
Resolution	120 ns
Pulse Delay	Zero to 100 ms where zero is <120 ns referred to trigger or sync pulse falling edge
Resolution	120 ns
Sync Output	120 ns pulse referred to trigger. Available at trigger socket.

Inputs/Outputs

Trigger in/out Rear-panel BNC connector provides either trigger input or sync output dependent upon trigger mode. TTL level.

Options 025a & 025b Internal Pulse Modulator

Option 025a (6822A and 6823A)

Frequency Range	50 MHz to 18 GHz (8.4 GHz for 6822). Usable to 20 GHz.
RF Output Range	The levelled power range is reduced by: <3 dB up to 6 GHz <4 dB up to 14 GHz <4.5 dB up to 18 GHz when pulse modulation is selected
RF Level Accuracy	Adds ± 0.3 dB to the levelled power accuracy specification when pulse modulation is enabled and for powers of <-1 dBm

GENERAL INFORMATION

Source Harmonics (with Pulse Modulation enabled)	
50 MHz – 2 GHz	<-35 dBc
2 GHz – 20 GHz	<-50 dBc
On/Off Ratio	
50 MHz – 1 GHz	>55 dB
1 GHz – 9 GHz	>60 dB
9 GHz – 17 GHz	>70 dB
17 GHz – 18 GHz	>80 dB
18 GHz – 20 GHz	>80 dB (typical)
Rise/Fall Times	(measured at 10% and 90% of edge)
Rise Time	<8 ns (typically <5 ns)
Fall Time	<12 ns (typically <9 ns)
Option 025b (6824A, 6825A and 6825AR)	
Frequency Range	50 MHz to 40 GHz (24 GHz for 6824A)
RF Output Range	The levelled power range is reduced by: <4 dB up to 12 GHz <5 dB up to 20 GHz <6 dB up to 30 GHz <8 dB up to 40 GHz when pulse modulation is selected
RF Level Accuracy	Adds ± 0.3 dB to the levelled power accuracy specification when pulse modulation is enabled and for powers of <-3 dBm
Source Harmonics (with Pulse Modulation enabled)	
50 MHz – 375 MHz	<-40 dBc
375 MHz – 24 GHz	<-50 dBc
24 GHz – 40 GHz	<-20 dBc
On/Off Ratio	
50 MHz – 10 GHz	>60 dB
10 GHz – 26.5 GHz	>60 dB (typically >70 dB)
26.5 GHz – 40 GHz	>60 dB (typically >80 dB)
Rise/Fall Times	(measured at 10% and 90% of edge)
Rise Time	<7 ns (typically <6 ns)
Fall Time	<11 ns (typically <10 ns)
Pulse Modulation Control	
Modes	Pulse, Pulse CW External (via rear-panel BNC connector) Internal (if Option 023 is fitted)
Control	Control of pulse modulation is: Internal via soft key menu when the modulation generator option (Option 023) is fitted or External via the rear-panel BNC Mod In/Out socket Level is TTL, High = On, Low = Off When pulse mod Off is selected, the output is the selected CW output level
Pulse CW	In both internal or external modes, allows setting of output level in the On condition for reference or calibration.

GENERAL INFORMATION

Scalar Analyzer

System Features

Frequency Range	As per source frequency range
Number of Inputs	3 detector inputs
Number of Measurement Points	User selectable from 2 to 1601
Applications	Return loss vs frequency Insertion loss vs frequency Fault Location Voltage vs frequency
Detection Modes	AC and DC
Noise Reduction	Averaging, 1 to 1000 Smoothing, 0.01 to 20%
Power Measurements	Using scalar detectors
Detector Correction	Frequency response and linearity read from EEPROM for 6230A/L and fault locators. Support for 6230 and autotesters.

Insertion Loss Measurements

Measurement Dynamic Range, AC Scalar Detection, with 623XA Detector	Max source output to -60 dBm Max source output to -65 dBm (with averaging) Typical values: >65 dB (10 MHz to 40 GHz) >75 dB (1 MHz to 3 GHz) only with 6232A
Measurement Update Rate	401 points in 270 ms with DC detection
Calibration	Through path calibration or short and short/open calibrations for single-ended insertion loss.
Inputs	Single input or ratio
Accuracy	Linearity + mismatch
Linearity (for Power Levels >-50 dBm)	±0.2 dB / 10 dB but not >0.5 dB in total

Return Loss Measurements

Measurement Update Rate	401 points in 270 ms with DC detection
Calibration	Short, Open, Short/Open
Inputs	Single input or ratio
Accuracy	Linearity + directivity + test port mismatch
Linearity (for Power Levels >-45 dBm)	±0.2 dB / 10 dB but not > 0.5 dB in total

Fault Location Measurements

Measurement Range	Up to 25 km depending on cable or waveguide loss
Units	Feet or meters.
Number of Measurement Points	User selectable from 50 to 1601
Minimum Resolution	
For two equal amplitude discontinuities using maximum sweep width	
6821A	12.18 x Vr cm
6822A	4.32 x Vr cm
6823A	1.82 x Vr cm
6824A	1.51 x Vr cm
6825A	0.91 x Vr cm
	where Vr is the relative velocity factor for the transmission line
Measurement Update Rate	512 points in 250 ms, DC detection
Dynamic Range	
DC detection	70 dB
AC detection	80 dB

GENERAL INFORMATION

Distance Accuracy	3 mm or 0.1% of range for a single fault
Transmission Line Database	Data supplied as standard
Required Accessory	624X series fault locator or 658X Series Transmission Line Test Head or accessory power divider (see Optional accessories)

Frequency Standard

Internal 10 MHz OCXO

Drift	± 5 in 10^8 over 0 to 55°C
Ageing	± 2 in 10^7 per year (OCXO)

External Frequency Standard

1 MHz or 10 MHz, via BNC connector

Rear Panel Connectors

RS-232	9-way D-type connector, male Baud rate 300 to 9600
GPIB Interface	GPIB is IEEE 488.1 and 488.2 compatible. The interface provides instrument control with full Talk/Listen capability.
Frequency Standard In/Out BNC	1 or 10 MHz input or 10 MHz output selectable from front panel
Mod In/Out BNC	Frequency modulation input or output. Rear-panel BNC connector, TTL levels. Impedance approx. 100 Ω .
Printer Output	USB/parallel interface. Printer is buffered to permit measurements to proceed whilst printing.
External Monitor	Standard VGA, 640 by 480 colour output 15-way high density D-type female connector
Voltage Output	Auxiliary 9-pin connector Settable for 0 to 10 V ramp, fixed voltage or chart recorder drive
External Levelling Input	
Input voltage range	0 to +1 V
Connector	BNC

General Features

Number of Display Channels	2
Number of Measurements	4 (2 per display channel)
Number of Measurement Points	2 to 1601 for one trace, scalar
Display	Colour active matrix TFT liquid crystal display with 16.5 cm (6.5 in) visible diagonal
Data Storage	External removable storage. Trace storage in DOS format.
Limits	4 stores of 12 segments each. Each segment defines an upper limit, upper and lower limits, or a point. Any store can be applied to any trace.

GENERAL INFORMATION

Markers	8 per trace plus separate delta marker
Marker Functions	Marker, delta marker, minimum, maximum, search left, search right, N-dB bandwidth (with center frequency), marker tracking
Scalar Analyzer	Active marker Max / Min Max / Min Tracking Find Pk-Pk Pk-Pk Tracking Search Right / Left Bandwidth / Optional CF/DF (Q) dB/Octave, dB/Decade Readout Delta Marker On/Off -1 dB Gain Compression
Fault Location	Find Max / Track Max Next Pk Right / Left Set Pk Level Delta marker On/Off
General	Marker Table Assign Active MKR / Position Active MKR Set Up Markers (i.e. On/Off, Position) Large Readout All Off
Marker Resolution	
Frequency	6 digits or 1 Hz, user selectable
Power	0.01 dB
Voltage	1 nV
Measurement Manipulation	Display live measurement. Display trace memory. Display live measurement relative to trace memory. Measurement hold may be applied for each trace. Any input or ratio of inputs may be assigned to any one or more than one trace(s). A trace may display absolute power, power relative to a path calibration or power minus a trace memory.
Input Offsets	An offset in the range -99.99 dB to +99.99 dB in 0.01 dB steps may be applied per detector input.

General

Weight - Variant and Option Dependent	16 kg (35 lb) max
Size (not including front handles)	230 mm H x 430 mm W x 570 mm D (9 in H x 17 in W x 22 in D)
Power Supply	100 to 240V~ 108 to 118V~ (limit 90 V to 264 V~) (Limit 98 V to 132 V~) 50 to 60 Hz 50 to 400 Hz (limit 45 Hz to 66 Hz) (limit 45 Hz to 440 Hz) 200 W maximum
Rated Range of Use	
Temperature	0 to +50°C 6825 and 6825R only; +5 to +45°C only
Humidity	Up to 93% RH at +40°C
Conditions of Storage and Transportation	
Temperature	-40 to +71°C
Humidity	Up to 93% RH at +40°C
Altitude	Up to 4570 m (15000 ft)

GENERAL INFORMATION

Electromagnetic Compatibility

Conforms to the protection requirements of EEC Council directive 2004/108/EC.

Conforms to the limits specified in the following standards:

IEC/EN61326-1 : 2006

RF Emission Class A, Immunity table 3.

The radiated RF emission from this equipment is below Class A (reference CISPR 11). Class A equipment is intended for use in industrial environments. There may be potential difficulties in ensuring electromagnetic compatibility in other environments due to radiated disturbances.

This instrument complies with Immunity Table 3 and is designed to operate in a controlled electromagnetic environment, i.e where RF transmitters such as mobile telephones may not be used in close proximity.

When using a 6230L detector, the noise floor may increase if exposed to a conducted RF disturbance level of >1.5 V.

Safety

Conforms with the requirements of EC Council Directive 2006/95/EC (as amended) and the product safety standard IEC/EN 61010-1 : 2001 + C1 : 2002 + C2 : 2003 for Class 1 portable equipment, for use in a Pollution Degree 2 environment. The instrument is designed to operate from an Installation Category 2 supply.

Note: All specifications quoted are for operation at calibration temperature $\pm 3^{\circ}\text{C}$.

Specifications involving Type N connectors above 18 GHz are not traceable to national standards as these do not exist at present.

Specifications involving 2.92 mm connectors above 40 GHz are not traceable to national standards as these do not exist at present.

Typical specifications are non-warranted.

Versions, options and accessories - 6820A series

Versions - RF and Microwave Scalar Analyzers

6821A	1 MHz to 3 GHz Scalar Analyzer
6822A	10 MHz to 8.4 GHz Scalar Analyzer
6823A	10 MHz to 20 GHz Scalar Analyzer
6824A	10 MHz to 24 GHz Scalar Analyzer
6825A	10 MHz to 46 GHz Scalar Analyzer
6825AR	10 MHz to 40 GHz Scalar Analyzer

Supplied Accessories

46886/067	CD-ROM containing:
46892/920	6820A/6840A Series Operating Manual
46892/922	6810A and 6820A/6840A Series Getting Started Guide
46892/921	6820A/6840A Series Remote Operating Manual
46892/931	6810A Series Operating/Remote Programming Manual
43123/076	AC Supply Lead
37591/755	Front Panel Cover

Options

002	Field Replaceable Precision N (f) and 3.5 mm (f) RF Connectors for source output (not available on 6821) or 2.92 mm (f) RF connector for 6825 and 6825R
010	3 GHz 110 dB Step Attenuator (only available for 6821)
011	20 GHz 70 dB Step Attenuator (only available for 6822/6823)
012	26.5 GHz 90 dB Step Attenuator (not available for 6821/6825/6825R)
013	40 GHz 70 dB Step Attenuator (only available for 6825 and 6825R)
023	Internal FM Generator (and Pulse Generator when Option 25 fitted)
025	Internal Pulse Modulator (Opt 25a 6822/6823), (Opt 25b 6824/6825/6825R)
030	Higher Output Power (not applicable to 6821/6825/6825R)

Complementary Product

6146	500 MHz to 18 GHz Pulse Modulator
54441/019	AC Power Supply for 6146
6147	70 MHz to 40 GHz Pulse Modulator

Optional accessories

6230A/L Scalar Detectors

6230A series	Standard Detectors (-65 dBm to +20 dBm typical)
6230A	10 MHz to 20 GHz, N type (m)
6232A	1 MHz to 3 GHz, N Type (m)
6233A	10 MHz to 26.5 GHz, 3.5 mm (m)
6234A	10 MHz to 46 GHz, 2.92 mm (m)
6230L series	Low VSWR detectors (-59 dBm to +26 dBm typical)
6230L	10 MHz to 20 GHz, N type (m)
6233L	10 MHz to 26.5 GHz, 3.5 mm (m)
6234L	10 MHz to 46 GHz, 2.92 mm (m)

GENERAL INFORMATION

Autotesters

59999/158	10 MHz to 18 GHz N (m)
59999/159	10 MHz to 18 GHz N (f)
59999/168	10 MHz to 40 GHz 2.92 mm (m)
59999/169	10 MHz to 40 GHz 2.92 mm (f)

RF Bridge

59999/170	5 MHz to 2 GHz N (f)
-----------	----------------------

Fault Locators

6242F	10 MHz to 3 GHz, N (f)
6242M	10 MHz to 3 GHz, N (m)
6240F	10 MHz to 20 GHz, N (f)
6240M	10 MHz to 20 GHz, N (m)
6243F	10 MHz to 26.5 GHz, 3.5 mm (f)
6243M	10 MHz to 26.5 GHz, 3.5 mm (m)
6241	10 MHz to 20 GHz, 7 mm

Microwave Ruggedized Cables for Fault Locators

54311/197	1.5 m, 18 GHz, N (m) to Right Angle N (m)
54311/198	3.0 m, 18 GHz, N (m) to Right Angle N (m)
54311/201	1.5 m, 26.5 GHz, 3.5 mm (m) to Right Angle 3.5 mm (m)
54311/202	3.0 m, 26.5 GHz, 3.5 mm (m) to Right Angle 3.5 mm (m)

RF Ruggedized Cables for Fault Locators

54311/199	1.5 m, 3 GHz, N (m) to Right Angle N (m)
54311/200	3.0 m, 3 GHz, N (m) to Right Angle N (m)

Microwave Ruggedized Cables

54311/116	1.5 m, 20 GHz, N (m) to N (m)
54311/109	3.0 m, 20 GHz, N (m) to N (m)
54311/117	1.5 m, 26.5 GHz, 3.5 mm (m) to 3.5 mm (m)
54311/110	3.0 m, 26.5 GHz, 3.5 mm (m) to 3.5 mm (m)

Fault Locator and Scalar Detector DC Cables

43139/099	1.5 m, DC Cable
43139/100	3.0 m, DC Cable
43139/101	10 m, DC Cable
43139/102	25 m, DC Cable
43139/103	50 m, DC Cable

Power Splitters/Dividers

54311/123	Power Splitter DC to 18 GHz, Type N
54311/124	Power Splitter DC to 26.5 GHz, 3.5 mm
54311/161	Power Splitter DC to 40 GHz, 2.92 mm
54311/187	Power Divider DC to 18 GHz
54311/188	Power Divider DC to 26.5 GHz

GENERAL INFORMATION

RF Ruggedized Cables for Bridges and Dividers

54311/195	1.5 m, 3 GHz, N (m) to N (m)
54311/196	3.0 m, 3 GHz, N (m) to N (m)

Fixed Loads

54421/020	7 mm Fixed Load
54421/021	3.5 mm (f) Fixed Load
54421/022	3.5 mm (m) Fixed Load
54421/023	N (m) Fixed Load
54421/024	N (f) Fixed Load

Precision Adapters

54311/175	N (m) to N (m)
54311/167	N (m) to N (f)
54311/174	N (f) to N (f)
54311/176	N (f) to 3.5 mm (f)
54311/177	N (m) to 3.5 mm (f)
54311/178	N (m) to 3.5 mm (m)
54311/185	N (f) to 3.5 mm (m)
54311/137	N (m) to TNC (f)
54311/138	N (m) to TNC (m)
54311/139	N (f) to TNC (f)
54311/186	N (f) to TNC (m)
54311/203	7 mm to N (f)
54311/204	7 mm to TNC (m)
54311/205	7 mm to TNC (f)
54311/136	TNC (m) to TNC (m)
54311/107	3.5 mm (f) to 3.5 mm (f)
54311/165	3.5 mm (m) to 3.5 mm (f)
54311/164	3.5 mm (m) to 3.5 mm (m)
54311/162	2.92 mm (m) to 2.92 mm (m)
54311/206	2.92 mm (m) to 2.92 mm (f)
54311/207	2.92 mm (f) to 2.92 mm (f)

Standard Adapters

54311/133	N (f) to SMA (f)
54311/134	N (m) to SMA (f)
54311/135	TNC (m) to SMA (m)

Miscellaneous Electrical Cable

54311/170	Positive Voltage Measurement Cable
54311/112	Negative Voltage Measurement Cable
43129/189	GPIB Cable
43139/042	BNC (m) to BNC (m) 1.5 m
46884/560	Parallel Printer Interface Cable
43137/604	Autotester Adapter Cable 0.5 m
43139/104	Autotester Adapter Cable 1.5 m

GENERAL INFORMATION

Standard Microwave Cables

54351/022	0.5 m, 18 GHz, N (m) to N (m)
54351/025	0.5 m, 26.5 GHz, 3.5 mm (m) to 3.5 mm (m)
54351/027	0.5 m, 40 GHz, 2.92 mm (m) to 2.92 mm (m)

Attenuators

56534/901	Precision Fixed Coaxial Attenuator 3 dB DC to 18 GHz 5 W, N(m) to N(f)
56534/902	Precision Fixed Coaxial Attenuator 6 dB DC to 18 GHz 5 W, N(m) to N(f)
56534/903	Precision Fixed Coaxial Attenuator 10 dB DC to 18 GHz 5 W, N(m) to N(f)
56534/904	Precision Fixed Coaxial Attenuator 20 dB DC to 18 GHz 5 W, N(m) to N(f)

Software Support

59000/327	MIPlot Software Pack
59000/371	Guided Scalar Measurements

Miscellaneous

46885/038	Rack Mount Kit for 6800A
46880/122	Service Manual (consists of maintenance manual (printed)+ operating manual (CD-ROM))
46882/920	6820A/6840A Series Operating Manual (printed)
46882/922	6810A and 6820A/6840A Series Getting Started Guide (printed)
46882/921	6820A/6840A Series Remote Operating Manual (printed)
84501	Soft Carrying Case
46662/695	Flight Case
54152/001	3.5 mm Torque Wrench
54211/008	Compact Keyboard

Performance data - 6840A series

Source

Functionality	Synthesized CW. Synthesized sweeper for use with scalar analyzer. Tracking generator for use with spectrum analyzer. Offset tracking generator for use with spectrum analyzer (offset by scale or multiplication factor). CW Power sweep. External frequency modulation Optional internal frequency modulation in spectrum, scalar and source-only modes
----------------------	--

Frequency Range

6841A/6848A	1 MHz to 3 GHz
6842A/6846A	10 MHz to 8.4 GHz
6843A/6847A	10 MHz to 20 GHz
6844A	10 MHz to 24 GHz
6845A	10 MHz to 46 GHz
6845AR	10 MHz to 40 GHz

Resolution (Settable)

to 46 GHz	1 Hz
-----------	------

CW Accuracy

(Frequency Standard error x Frequency) ± 10 Hz

Swept Accuracy (Typical)

300 µs Step Time	
1 MHz to 3 GHz	<20 kHz
3 GHz to 46 GHz	<200 kHz
1 ms Step Time	
1 MHz to 3 GHz	<1 kHz
3 GHz to 46 GHz	<10 kHz
10 ms Step Time	
1 MHz to 3 GHz	<100 Hz
3 GHz to 46 GHz	<1 kHz

Levelled Power Range

6841/2/3/4/6/7/8A standard	
1 MHz to 3 GHz	-10 dBm to +10 dBm
3 GHz to 24 GHz	-10 dBm to +5 dBm
6842/3/4/6/7/8A + option 030 (higher power)	
1 MHz to 24 GHz	-10 dBm to +10 dBm
6841A/48A + option 010 (110 dB Step Attenuator)	
1 MHz to 3 GHz	-120 dBm to +8 dBm
6842/3/6/7A + option 011 (70 dB Step Attenuator)	
10 MHz to 3 GHz	-80 dBm to +8 dBm
3 GHz to 20 GHz	-80 dBm to +2 dBm
+ option 030 (higher power)	
3 GHz to 20 GHz	-80 dBm to +7 dBm
6842/3/4/6/7A + option 012 (90 dB Step Attenuator)	
10 MHz to 3 GHz	-100 dBm to +8 dBm
3 GHz to 24 GHz	-100 dBm to +2 dBm
+ option 030 (higher power)	
3 GHz to 24 GHz	-100 dBm to +7 dBm

GENERAL INFORMATION

6845A and 6845AR	
10 MHz to 8 GHz	-10 dBm to +8 dBm, +10 dBm typical
8 GHz to 20 GHz	-10 dBm to +5 dBm, +7 dBm typical
20 GHz to 24 GHz	-10 dBm to +4 dBm, +6 dBm typical
24 GHz to 40 GHz	-10 dBm to 0 dBm, +3 dBm typical
40 GHz to 46 GHz	-10 dBm to 0 dBm typical (excluding the effect of connector moding)

6845A and 6845AR + option 013 (70 dB Step Attenuator)	
10 MHz to 8 GHz	-80 dBm to +6 dBm, +8 dBm typical
8 GHz to 20 GHz	-80 dBm to +2 dBm, +4 dBm typical
20 GHz to 24 GHz	-80 dBm to +1 dBm, +3 dBm typical
24 GHz to 40 GHz	-80 dBm to -3 dBm, 0 dBm typical

Note: For option 002 (Field Replaceable Connectors) guaranteed levelled output is reduced by 0.5 dB.

Settable Power Resolution 0.01 dB

Power Sweep Range (from Maximum Levelled Power) without Attenuator >20 dB

External Frequency Modulation

Peak deviation (1 V peak output)	
10 MHz - 375 MHz	1 kHz to 5 MHz
375 MHz - 750 MHz	250 Hz to 1.25 MHz
750 MHz - 1.5 GHz	500 Hz to 2.5 MHz
1.5 GHz - 3 GHz	1 kHz to 5 MHz
3 GHz - 46 GHz	20 kHz to 1 MHz
Accuracy (1 kHz modulating frequency)	
20 - 400 kHz deviation	± 3% of indication ± 1 Hz excluding residual FM
-3 dB bandwidth, AC coupled mode	
10 MHz - 3 GHz	< 100 Hz to > 1 MHz typical
3 GHz - 46 GHz	< 100 Hz to > 500 kHz typical
-3 dB bandwidth, DC coupled mode	
10 MHz - 3 GHz	DC to > 1 MHz typical
3 GHz - 46 GHz	DC to > 500 kHz typical

Internal Modulation Generator Option 022, 023 (Group Delay)

FM Source	Modulation signal sine wave, 0.1 Hz to 500 kHz, resolution 0.1 Hz Other specifications as for External Frequency Modulation except:
Accuracy (1 kHz modulating frequency)	20 to 400 kHz deviation ±5% of indication ±1 Hz excluding residual FM
Pulse Generator Source	
Modes	Single pulse
Trigger Modes	External, internal continuous
Pulse Widths (PW)	120 ns to >1 s
Resolution	120 ns
Pulse Period (PRI)	240 ns to 7 s (PRF <1 Hz to 4.16 MHz)
Resolution	120 ns
Pulse Delay	Zero to 100 ms where zero is <120 ns referred to trigger or sync pulse falling edge
Resolution	120 ns
Sync Output	120 ns pulse referred to trigger. Available at trigger socket.

GENERAL INFORMATION

Inputs/Outputs

Trigger in/out

Rear-panel BNC connector provides either trigger input or sync output dependent upon trigger mode. TTL level.

Internal Levelling Accuracy at 0 dBm (no options fitted)

1 MHz to 3 GHz	± 0.7 dB
3 GHz to 24 GHz	± 1.0 dB
24 GHz to 40 GHz	± 1.5 dB

Levelled Power Accuracy (with Options 010, 011, 012, 013)

1 MHz to 3 GHz	$< \pm 1$ dB (± 0.3 dB or 2% of attenuator setting in dB whichever is the greater)
3 GHz to 24 GHz	$< \pm 1$ dB (± 1 dB or 4% of attenuator setting in dB whichever is the greater)
24 GHz to 40 GHz	$< \pm 1.5$ dB (± 1 dB or 4% of attenuator setting in dB whichever is the greater)

GENERAL INFORMATION

Linearity (no options fitted, Option 030) over Levelled Power Range relative to 0 dBm

1 MHz to 40 GHz < ±0.5 dB

Power Stability with Temperature (typical)

1 MHz to 40 GHz < 0.1 dB/°C

Harmonics and Sub-Harmonics Over Levelled Power Range

Harmonics

<70 MHz	< -25 dBc
70 MHz to 3 GHz	< -55 dBc
3 GHz to 24 GHz	< -50 dBc
24 GHz to 40 GHz	< -20 dBc

Sub-Harmonics

1 MHz to 3 GHz	< -60 dBc
3 GHz to 24 GHz	none
24 GHz to 40 GHz	< -40 dBc

Spurious Signals (Typical)

For carrier frequencies <375 MHz

30 kHz to 150 kHz offset	< -50 dBc
150 kHz to 1 MHz offset	< -55 dBc
>1 MHz offset	<-55 dBc

For carrier frequencies >375 MHz

30 kHz to 150 kHz offset	< -50 dBc
150 kHz to 1 MHz offset	< -60 dBc
> 1 MHz offset	< -60 dBc

Phase Noise in dBc/Hz in CW mode

CW Frequency	Frequency offset		
	1 kHz	10 kHz	100 kHz
0.25 GHz	-86	-95	-108
0.5 GHz	-98	-112	-134
1 GHz	-92	-106	-128
2 GHz	-86	-100	-122
4 GHz	-80	-92	-100
10 GHz	-72	-84	-90
20 GHz	-66	-78	-82
24 GHz	-64	-76	-80
40 GHz	-63	-75	-79

Source Match (Typical)

1 MHz to 3 GHz	15 dB
3 GHz to 20 GHz	10 dB
20 GHz to 40 GHz	8 dB

Output Connector

6841/2/3/6/7/8A	Precision Type N, female
6844A	Precision 3.5 mm, female
6845A	Precision 2.92 mm female

Or optional field replaceable connectors

GENERAL INFORMATION

Spectrum Analyzer

Frequency

Frequency Range		
6841A	1 MHz to 3 GHz (usable to 4.2 GHz)	
6842A, 6843A, 6848A	10 MHz to 20 GHz	
6844A, 6846A	10 MHz to 24 GHz (usable to 30 GHz)	
6845A	10 MHz to 46 GHz	
6845AR	10 MHz to 40 GHz	
6847A	10 MHz to 26.5 GHz (usable to 30 GHz)	
	Extendible for all units to 110 GHz in waveguide only with external waveguide mixers. The 6840A series unit must be fitted with option 020.	
Frequency Span Range	Full span to zero span, plus any intermediate value	
Start Frequency Accuracy	(start frequency x frequency standard error) ±frequency readout resolution ± 3% of span ± 20% resolution bandwidth setting	
Span Accuracy	Fully synthesized for spans of 20 MHz or less ± 3% for spans >20 MHz	
Number of Measurement Points	Fixed 512	
Frequency Readout Resolution	Span/512	
Marker Readout Accuracy	As per start frequency accuracy	
Sweep Speed	Auto coupled or user set 10 ms/div to 50 s/div	
Phase Noise in dBc/Hz		
Analyzer frequency	20 kHz frequency offset	100 kHz frequency offset
10 MHz	-90	-100
4.2 GHz (N=1 on the harmonic mixer)	-90	-100
8.6 GHz (N=2 on the harmonic mixer)	-84	-94
18.5 GHz (N=3 on the harmonic mixer)	-77	-87
38 GHz (N=6 on the harmonic mixer)	-73 typ	-83 typ
System Related Sidebands	< -65 dBc at offsets greater than 30 kHz from the carrier.	

Amplitude

Maximum Input Amplitude	+20 dBm
Damage Level	+27 dBm at >10 dB attenuation +20 dBm at 0 dB attenuation
Input Return Loss (typical) with ≥ 10 dB Input Attenuation	
10 MHz to 3 GHz	20 dB
3 GHz to 12 GHz	12 dB
12 GHz to 40 GHz*	10 dB
Input Connector	
6841/2/3/8A	Precision Type N, female
6844/6/7A	Precision 3.5 mm, female
6845A	Precision 2.92 mm female
	Or optional field replaceable connectors
Input Attenuator	Range: 0 to 60 dB in 10 dB steps
Reference Level	Range: +30 dBm to -99 dBm
Amplitude Scaling	Range: 10 dB/div to 0.1 dB/div

GENERAL INFORMATION

Amplitude Accuracy at 0 dBm Reference Level and 0 dBm Input (at selected bandwidth)

10 MHz to 3 GHz	± 1 dB
to 4.2 GHz*	± 1.5 dB
to 20 GHz	± 4.0 dB
to 24 GHz**	± 4.5 dB
to 40 GHz	± 5 dB

* does not apply to 6841A

** to 26.5 GHz for 6847A

Incremental Reference Level Accuracy from +20 dBm to -40 dBm (Typical)	±0.5 dB
Response Flatness (Typical)	±3.0 dB
Log Incremental Accuracy (Typical)	0.2 dB / 10 dB
Display Linearity	±1.5 dB over 8 divisions (10 dB/div)
Gain Compression (0 dB Attenuation)	< 0.5 dB with -10 dBm at the input connector
Resolution Bandwidth Range	1 kHz to 3 MHz in 1, 3, 10 sequences
Resolution Bandwidth Accuracy	± 20 %
Resolution Bandwidth Selectivity (60 dB / 3 dB ratio)	
1 kHz to 3 MHz	15:1
Resolution Bandwidth Switching Error	< 0.25 dB
Video Bandwidth	1, 3, 10, 30, 100, 300, Hz 1, 3, 10, 30, and 100 kHz
Third Order Intermodulation Response (0 dB attenuation)	< -70 dBc with 2 tones each -30 dBm, with > 50 kHz separation applied at the input connector
Third Order Intercept Point	> +5 dBm
Second Order Single Tone Intercept Point	> +45 dBm
Second Harmonic Distortion >40 MHz and at -40 dBm	< -70 dBc for -40 dBm at the input connector with 0 dB attenuation
Residual Responses (Input Terminated with 50 ohm)	< -90 dBm
Other Input-Related Spurious (0 dB attenuation)	< -60 dBc with -10 dBm on the input connector
Displayed Average Noise Level in 1 kHz RBW, 30 Hz VBW, 0 dBm Attenuation (Input Terminated with 50 ohm)	
At 1 GHz	< -105 dBm
At 6 GHz	< -100 dBm
At 12 GHz	< -100 dBm
At 18 GHz	< -95 dBm
At 38 GHz	< -80 dBm typical

External Mixer Interface (Option 020)

LO output	4.5 - 9.2 GHz at +17 dBm typical
IF input	479.3 MHz, maximum level -15 dBm typical Connectors SMA (female)

Demodulation

Narrow band FM, <20 kHz
Display, kHz vs time
Audio output via speaker

GENERAL INFORMATION

Measurement Features

Frequency counter
 Ability to display channel occupancy masks, user defined
 Accurate marker frequency readout
 Multiple markers
 Two independent channels
 Scrollable center frequency, span and resolution bandwidth
 Measurement of noise in a 1 Hz bandwidth
 Auto-tune display set-up for CW signals
 NBFM demodulator with audio output
 Demodulated output displayed on screen
 Speed 1 ms/div to 1 s/div

Millimeter waveguide, single diode harmonic mixers

Available for all 684XA units, Option 020 external mixer interface is required.

Model Number	Frequency Range	Waveguide Designation	Flange Type
M42HW	18-26.5 GHz	WR42, WG20, R220	UG-597/U
M28HW	26.5-40 GHz	WR28, WG22, R320	UG-599/U
M22HW	33-50 GHz	WR22, WG23, R400	UG-383/U
M19HW	40-60 GHz	WR19, WG24, R500	UG-383/U
M15HW	50-75 GHz	WR15, WG25, R620	UG-385/U
M12HW	60-90 GHz	WR12, WG26, R740	UG-387/U
M10HW	75-110 GHz	WR10, WG27, R900	UG-387/U

A Diplexer (DPL.313A) is required for use with the mixers listed above. It is supplied with two SMA (m) barrel adapters for IF and LO interconnection to the spectrum analyzer Option 020 connectors and a 1 m long, high quality interconnecting cable for connection between mixer and diplexer.

Scalar Analyzer

System Features

Frequency Range	As per source frequency range
Number of Inputs	3 detector inputs plus tuned input
Number of Measurement Points	User selectable from 2 to 1601
Applications	Return loss vs frequency Insertion loss vs frequency Fault Location Voltage vs frequency Group Delay vs Frequency (optional)
Detection Modes	AC and DC
Noise Reduction	Averaging, 1 to 1000 Smoothing, 0.01 to 20%
Power Measurements	Using scalar detectors
Detector Correction	Frequency response and linearity read from EEPROM for 6230A/L and fault locators. Support for 6230 and autotesters.

Insertion Loss Measurements

Measurement Dynamic Range, AC Scalar Detection, with 623xA Detector	Max source output to -60 dBm Max source output to -65 dBm (with averaging) Typical values: >65 dB (10 MHz to 40 GHz) >75 dB (1 MHz to 3 GHz) only with 6232A
Measurement Dynamic Range, Tuned Input	Maximum source output to -75 dBm Typically >80 dB (10 MHz to 17 GHz)
Measurement Update Rate	401 points in 270 ms with DC detection
Calibration	Through-path calibration or short and short/open calibrations for single-ended insertion loss.
Inputs	Single input or ratio
Accuracy (detector inputs and tuned input)	Linearity + mismatch
Linearity (applies after normalization)	
Linearity (for Power Levels > -45 dBm) scalar detector inputs	±0.2 dB / 10 dB but not >0.5 dB in total

GENERAL INFORMATION

Linearity (tuned input)	
Log incremental accuracy (typical)	0.2 dB/10 dB
Display Linearity	±1.5 dB over 8 divisions (10 dB/div)

Return loss measurements

Measurement Update Rate	401 points in 270 ms with DC detection
Calibration	Short, Open, Short/Open
Inputs	Single input or ratio
Accuracy	Linearity + directivity + test port mismatch
Linearity (for Power Levels >-45 dBm)	±0.2 dB / 10 dB but not > 0.5 dB in total

Fault Location Measurements

Measurement Range	Up to 25 km depending on cable or waveguide loss
Units	Feet or meters
Number of Measurement Points	User selectable from 50 to 1601
Minimum Resolution	
For two equal amplitude discontinuities using maximum sweep width	
6841/8A	12.18 x Vr cm
6842/6A	4.32 x Vr cm
6843/7A	1.82 x Vr cm
6844A	1.51 x Vr cm
6845A	0.91 x Vr cm
	where Vr is the relative velocity factor for the transmission line
Measurement Update Rate	512 points in 250 ms, DC detection
Dynamic Range	
DC detection	70 dB
AC detection	80 dB
Distance Accuracy	3 mm or 0.1% of range for a single fault
Transmission Line Database	Data supplied as standard
Required Accessory	624X series fault locator or 658X Series Transmission Line Test Head or RF Divider

Group Delay

Measurement Range	± 1 µs to ± 10 µs
Resolution* (3 MHz aperture)	0.1 ns to 15 GHz 0.2 ns 15 to 30 GHz 0.3 ns 30 to 40 GHz
Absolute Accuracy* (3 MHz aperture)	± 0.5 ns 10 MHz to 24 GHz ± 2.5 ns 24 GHz to 40 GHz
*excluding effects of imperfect match	
Relative Accuracy (for peak-to peak measurements)	As Resolution (typical)
Scales	0.1 ns/div to 5 µs/div in a 1,2,5 sequence with increment keys. Keypad entry provides user scaling.
Reference delay	Defaults to zero, user selectable.
Reference position	User selectable, default is centre display.
Delay offset	User entry of offset value.
Trace displays	Simultaneous amplitude and group delay vs frequency. Absolute delay and "zoom" display vs frequency. Dual channel mode. Comparison over same frequency range at same centre frequency. Comparison over different centre frequencies.

GENERAL INFORMATION

Frequency Standard

Internal 10 MHz OCXO

Drift	± 5 in 10^8 over 0 to 55°C
Ageing	± 2 in 10^7 per year (OCXO)

External Frequency Standard

1 MHz or 10 MHz

Rear Panel Connectors

RS-232	9-way D-type connector, male Baud rate 300 to 9600
GPIB Interface	GPIB is IEEE 488.1 and 488.2 compatible. The interface provides instrument control with full Talk/Listen capability.
10.7 MHz IF Output	IF output from Spectrum Analyzer. BNC connector.
Frequency Standard	1 or 10 MHz input or 10 MHz output selectable from front panel. BNC connector.
Mod In/Out	Frequency modulation input or output. Rear-panel BNC connector, TTL levels. Impedance approx. 100 Ω
Printer Output	USB/parallel interface. Printer is buffered to permit measurements to proceed whilst printing.
External Monitor	Standard VGA, 640 by 480 colour output 15-way high density D-type female connector
Voltage Output (Auxiliary 9-pin connector)	Settable for 0 to 10 V ramp, fixed voltage or chart recorder drive
Video Output (Auxiliary 9-pin connector)	Output from spectrum analyzer detector Bandwidth: as per RBW setting
External Levelling Input	
Input voltage range	0 to +1 V
Connector	BNC

General Measurement Features

Number of Display Channels	2
Number of Measurements	4 (2 per display channel)
Number of Measurement Points	2 to 1601 for one trace, scalar 512 fixed, spectrum
Display	Colour active matrix TFT liquid crystal display with 16.5 cm (6.5 in) visible diagonal
Data Storage	External removable storage. Trace storage in DOS format.
Limits	4 stores of 12 segments each. Each segment defines an upper limit, upper and lower limits, or a point. Any store can be applied to any trace.

GENERAL INFORMATION

Markers	8 per trace plus separate delta marker
Marker Functions	Marker, delta marker, minimum, maximum, search left, search right, N-dB bandwidth (with center frequency), marker tracking.
Spectrum Analyzer	Find Peak / Next Peak (next lowest amplitude or next Left / Right) / Identity Peaks MKR to CF MKR to Ref Level Counter / Set Resolution Measure Relative to Carrier (dBc) Search Left / Right Delta MKR / Set Span / Fixed Delta
Scalar Analyzer	Active marker Max / Min Max / Min Tracking Find Pk-Pk PK-PK Tracking Search Right / Left Bandwidth / Optional CF/DF (Q) dB/Octave, dB/Decade Readout Delta Marker On/Off -1 dB Gain Compression Peak-to-peak delay between two markers Max peak-to-peak delay in a user-defined bandwidth Deviation from linear between two markers Deviation from parabolic between two markers
Fault Location	Find Max / Track Max Next Pk Right / Left Set Pk Level Delta marker On/Off
General	Marker Table Assign Active MKR / Position Active MKR Set up Markers (i.e. On / Off, Position) Large Readout All Off
Marker Resolution	
Frequency	6 digits or 1 Hz, user selectable
Power	0.01 dB
Voltage	1 nV
Measurement Manipulation	Display live measurement. Display trace memory. Display live measurement relative to trace memory. Measurement hold may be applied for each trace. Any input or ratio of inputs may be assigned to any one or more than one trace(s). A trace may display absolute power, power relative to a path calibration or power minus a trace memory.
Input Offsets	An offset in the range -99.99 dB to +99.99 dB in 0.01 dB steps may be applied per detector input.

General

Weight - Variant and Option Dependent	24 kg (53 lb) max.	
Size (not including front handles)	230 mm H x 430 mm W x 570 mm D (9 in H x 17 in W x 22 in D)	
Power Supply	100 to 240V~ (limit 90 V to 264 V~)	108 to 118V~ (Limit 90 V to 132 V~)
	50 to 60 Hz (limit 45 Hz to 66 Hz)	50 to 400 Hz (limit 45 Hz to 440 Hz)
	300 W maximum	
Rated Range of Use		
Temperature	0 to +50°C 6825A and 6845A only; +5 to +45°C	
Humidity	Up to 93% RH at +40°C	

GENERAL INFORMATION

Conditions of Storage and Transportation

Temperature	-40 to +71°C
Humidity	Up to 93% RH at +40°C
Altitude	Up to 4570 m (15000 ft)

Electromagnetic Compatibility

Conforms to the protection requirements of EC Council directive 2004/108/EC.
Conforms to the limits specified in the following standards

IEC/EN 61326-1 : 2006
RF Emission Class A, Immunity table 3

Safety

Conforms with the requirements of EC Council Directive 2006/95/EC (as amended) and the product safety standard IEC/EN 61010-1 : 2001 + C1 : 2002 + C2 : 2003 for Class 1 portable equipment, for use in a Pollution Degree 2 environment. The instrument is designed to operate from an Installation Category 2 supply.

Note: All specifications quoted are for operation at calibration temperature $\pm 3^{\circ}\text{C}$.

Specifications involving Type N connectors above 18GHz are not traceable to national standards as these do not exist at present.

Specifications involving 2.92 mm connectors above 40 GHz are not traceable to national standards as these do not exist at present.

Typical specifications are non-warranted.

Versions, options and accessories - 6840A series

Versions - Microwave System Analyzers

6841A	1 MHz to 3 GHz Scalar Analyzer with 4.2 GHz Spectrum Analyzer
6842A	10 MHz to 8.4 GHz Scalar Analyzer with 20 GHz Spectrum Analyzer
6843A	10 MHz to 20 GHz Scalar Analyzer with 20 GHz Spectrum Analyzer
6844A	10 MHz to 24 GHz Scalar Analyzer with 24 GHz Spectrum Analyzer
6845A	10 MHz to 46 GHz Scalar Analyzer with 46 GHz Spectrum Analyzer
6845AR	10 MHz to 40 GHz Scalar Analyzer with 40 GHz Spectrum Analyzer
6846A	10 MHz to 8.4 GHz Scalar Analyzer with 24 GHz Spectrum Analyzer
6847A	10 MHz to 20 GHz Scalar Analyzer with 26.5 GHz Spectrum Analyzer
6848A	1 MHz to 3 GHz Scalar Analyzer with 20 GHz Spectrum Analyzer

Supplied Accessories

46886/067	CD-ROM containing:
46892/920	6820A/6840A Series Operating Manual
46892/922	6810A and 6820A/6840A Series Getting Started Guide
46892/921	6820A/6840A Series Remote Operating Manual
46892/931	6810A Series Operating/Remote Programming Manual
43123/076	AC Supply Lead
37591/755	Front Panel Cover

Options

002	Field Replaceable Precision N (f) or 3.5 mm (f) RF Connectors for Source Output and Spectrum Analyzer for 6842/6843/6844/6846/6847 Field Replaceable Precision N (f) or 2.92 mm (f) RF Connectors for Source and Spectrum Analyzer for 6845 and 6845R
010	3 GHz, 110 dB Step Attenuator (only available for 6841A and 6848A)
011	20 GHz, 70 dB Step Attenuator (only available for 6842A/6843A/6846A/6847A)
012	26.5 GHz 90 dB Step Attenuator (not available for 6841A/6845A/6845AR/6848A)
013	40 GHz 70 dB Step Attenuator (only available for 6845A and 6845AR)
020	External Mixer Interface
022	Group Delay
023	Internal Modulation (included in Group Delay Option 022)
030	Higher Power Output (not applicable to 6841A/6848A/6845A/6845AR)

Complementary Product

6146	500 MHz to 18 GHz Pulse Modulator
54441/019	AC Power Supply (for 6146)
6147	70 MHz to 40 GHz Pulse Modulator

Optional accessories

6230A/L Scalar Detectors

6230A series	Standard Detectors (-65 dBm to +20 dBm typical)
6230A	10 MHz to 20 GHz, N type (m)
6232A	1 MHz to 3 GHz, N Type (m)
6233A	10 MHz to 26.5 GHz, 3.5 mm (m)
6234A	10 MHz to 46 GHz, 2.92 mm (m)
6230L series	Low VSWR detectors (-59 dBm to +26 dBm typical)
6230L	10 MHz to 20 GHz, N type (m)
6233L	10 MHz to 26.5 GHz, 3.5 mm (m)
6234L	10 MHz to 46 GHz, 2.92 mm (m)

Autotesters

59999/151	10 MHz to 18 GHz 7 mm
59999/158	10 MHz to 18 GHz N (m)
59999/159	10 MHz to 18 GHz N (f)
59999/152	10 MHz to 26.5 GHz 3.5 mm WSMA (m)
59999/166	10 MHz to 26.5 GHz 3.5 mm WSMA (f)
59999/168	10 MHz to 40 GHz 2.92 mm (m)
59999/169	10 MHz to 40 GHz 2.92 mm (f)

RF Bridge

59999/170	5 MHz to 2 GHz N (f)
-----------	----------------------

Fault Locators

6242F	10 MHz to 3 GHz, N (f)
6242M	10 MHz to 3 GHz, N (m)
6240F	10 MHz to 20 GHz, N (f)
6240M	10 MHz to 20 GHz, N (m)
6243F	10 MHz to 26.5 GHz, 3.5 mm (f)
6243M	10 MHz to 26.5 GHz, 3.5 mm (m)
6241	10 MHz to 20 GHz, 7 mm

Microwave Ruggedized Cables for Fault Locators

54311/197	1.5 m, 18 GHz, N (m) to Right Angle N (m)
54311/198	3.0 m, 18 GHz, N (m) to Right Angle N (m)
54311/201	1.5 m, 26.5 GHz, 3.5 mm (m) to Right Angle 3.5 mm (m)
54311/202	3.0 m, 26.5 GHz, 3.5 mm (m) to Right Angle 3.5 mm (m)

RF Ruggedized Cables for Fault Locators

54311/199	1.5 m, 3 GHz, N (m) to Right Angle N (m)
54311/200	3.0 m, 3 GHz, N (m) to Right Angle N (m)

Transmission Line Test Heads

56581/001	10 MHz to 20 GHz Transmission Line Test Head, 6581
56583/001	10 MHz to 26.5 GHz Transmission Line Test Head, 6583

GENERAL INFORMATION

Microwave Ruggedized Cables for Test Heads

54311/116	1.5 m, 20 GHz, N (m) to N (m)
54311/109	3.0 m, 20 GHz, N (m) to N (m)
54311/117	1.5 m, 26.5 GHz, 3.5 mm (m) to 3.5 mm (m)
54311/110	3.0 m, 26.5 GHz, 3.5 mm (m) to 3.5 mm (m)

Scalar Detector and Fault Locator DC Cables (color coded blue)

43139/099	1.5 m, DC Cable
43139/100	3.0 m, DC Cable
43139/101	10 m, DC Cable
43139/102	25 m, DC Cable
43139/103	50 m, DC Cable

Millimeter Waveguide, Single Diode Harmonic Mixers

Model Number	Frequency Range	Waveguide Designation	Flange Type
M42HW	18-26.5 GHz	WR42, WG20, R220	UG-597/U
M28HW	26.5-40 GHz	WR28, WG22, R320	UG-599/U
M22HW	33-50 GHz	WR22, WG23, R400	UG-383/U
M19HW	40-60 GHz	WR19, WG24, R500	UG-383/U
M15HW	50-75 GHz	WR15, WG25, R620	UG-385/U
M12HW	60-90 GHz	WR12, WG26, R740	UG-387/U
M10HW	75-110 GHz	WR10, WG27, R900	UG-387/U

For other frequencies and sizes please consult Aeroflex for details.

A Diplexer (DPL.313A) is required for use with the mixers listed above. It is supplied with two SMA (m) barrel adapters for IF and LO interconnection to the spectrum analyzer Option 020 connectors and a 1 meter long, high quality interconnecting cable for connection between mixer and diplexer.

Power Splitters/Dividers

54311/123	Power Splitter DC to 18 GHz, Type N
54311/124	4 Power Splitter DC to 26.5 GHz, 3.5 mm
54311/161	Power Splitter DC to 40 GHz, 2.92 mm
54311/187	Power Divider DC to 18 GHz
54311/188	Power Divider DC to 26.5 GHz

RF Ruggedized Cables for Bridges and Dividers

54311/195	1.5 m, 3 GHz, N (m) to N (m)
54311/196	3.0 m, 3 GHz, N (m) to N (m)

Fixed Loads

54421/020	7 mm Fixed Load
54421/021	3.5 mm (f) Fixed Load
54421/022	3.5 mm (m) Fixed Load
54421/023	N (m) Fixed Load
54421/024	N (f) Fixed Load

GENERAL INFORMATION

Precision Adapters

54311/175	N (m) to N (m)
54311/167	N (m) to N (f)
54311/174	N (f) to N (f)
54311/176	N (f) to 3.5 mm (f)
54311/177	N (m) to 3.5 mm (f)
54311/178	N (m) to 3.5 mm (m)
54311/185	N (f) to 3.5 mm (m)
54311/137	N (m) to TNC (f)
54311/138	N (m) to TNC (m)
54311/139	N (f) to TNC (f)
54311/186	N (f) to TNC (m)
54311/203	7 mm to N (f)
54311/204	7 mm to TNC (m)
54311/205	7 mm to TNC (f)
54311/136	TNC (m) to TNC (m)
54311/107	3.5 mm (f) to 3.5 mm (f)
54311/165	3.5 mm (m) to 3.5 mm (f)
54311/164	3.5 mm (m) to 3.5 mm (m)
54311/162	2.92 mm (m) to 2.92 mm (m)
54311/206	2.92 mm (m) to 2.92 mm (f)
54311/207	2.92 mm (f) to 2.92 mm (f)

Standard Adapters

54311/133	N (f) to SMA (f)
54311/134	N (m) to SMA (f)
54311/135	TNC (m) to SMA (m)

Miscellaneous Electrical Cables

54311/170	Positive Voltage Measurement Cable
54311/112	Negative Voltage Measurement Cable
43129/189	GPIB Cable
43139/042	BNC (m) to BNC (m) 1.5 m
46884/560	Parallel Printer Interface Cable
43137/604	Autotester Adapter Cable 0.5 m
43139/107	Autotester Adapter Cable 1.5 m

Standard Microwave Cables

54351/022	0.5 m, 18 GHz, N (m) to N (m)
54351/025	0.5 m, 26.5 GHz, 3.5 mm (m) to 3.5 mm (m)
54351/027	0.5 m, 40 GHz, 2.92 mm (m) to 2.92 mm (m)

Attenuators

56534/901	Precision Fixed Coaxial Attenuator 3 dB DC to 18 GHz 5 W, N(m) to N(f)
56534/902	Precision Fixed Coaxial Attenuator 6 dB DC to 18 GHz 5 W, N(m) to N(f)
56534/903	Precision Fixed Coaxial Attenuator 10 dB DC to 18 GHz 5 W, N(m) to N(f)
56534/904	Precision Fixed Coaxial Attenuator 20 dB DC to 18 GHz 5 W, N(m) to N(f)

GENERAL INFORMATION

Software Support

59000/327

MIPlot Software Pack

59000/371

Guided Scalar Measurements

Miscellaneous

46885/038

Rack Mount Kit for 6840A

46880/122

Service Manual (consists of maintenance manual (printed) + operating manual (CD-ROM))

46882/920

6820A/6840A Series Operating Manual (printed)

46882/922

6810A and 6820A/6840A Series Getting Started Guide (printed)

46882/921

6820A/6840A Series Remote Operating Manual (printed)

84501

Soft Carrying Case

46662/695

Flight Case

54152/001

3.5 mm Torque Wrench

54211/008

Compact Keyboard

522388

1.25 GHz Active Probe

EC Declaration of Conformity

Refer to the manufacturer for a copy of the Declaration of Conformity for this instrument.

Chapter 2 INSTALLATION

Contents

Installation requirements	2-1
Power requirements	2-4
Goods-in checks	2-4
RS232 connections	2-4
GPIB connections	2-5
AUX connections	2-5
MONITOR connections	2-6
PARALLEL PORT connections	2-6
Rack mounting the instrument.....	2-6
Battery replacement.....	2-7
Routine maintenance	2-7
Cleaning	2-7
Microwave connectors	2-7
Routine safety testing and inspection	2-8
Putting into storage.....	2-9

List of figures

Fig. 2-1 RS232 connector contact assignments.....	2-4
Fig. 2-2 GPIB connector contact assignments.....	2-5
Fig. 2-3 AUX connector contact assignments	2-5
Fig. 2-4 MONITOR connector contact assignments	2-6
Fig. 2-5 PARALLEL PORT connector contact assignments	2-6

WARNING

Initial visual inspection

After unpacking the equipment, inspect the shipping container and its cushioning material for signs of stress or damage. If damage is identified, retain the packing material for examination by the carrier in the event that a claim is made. Examine the equipment for signs of damage; do not connect the equipment to a supply when damage is present, internal electrical damage could result in shock if the equipment is turned on.

CAUTION

Installation requirements

Ventilation

This equipment is forced air cooled by a fan mounted on the rear panel. Air must be allowed to circulate freely through the ventilator grills located on the side and underside of the equipment. Before switching on the equipment, ensure that the air inlet on the rear panel is not restricted (i.e. clearance of at least 75 mm at the rear, 25 mm at each side, 15 mm on the underside), or obstructed with loose material that could be sucked into the fan. Failure to provide adequate clearances will increase internal temperatures and reduce the equipment reliability, so its performance may not meet specification.

Class I power cords (3-core)

General

When the equipment has to be plugged into a Class II (ungrounded) 2-terminal socket outlet, the cable should either be fitted with a 3-pin Class I plug and used in conjunction with an adapter incorporating a ground wire, or be fitted with a Class II plug with an integral ground wire. The ground wire must be securely fastened to ground. Grounding one terminal on a 2-terminal socket will not provide adequate protection.

In the event that a moulded plug has to be removed from a lead, it must be disposed of immediately. A plug with bare flexible cords is hazardous if engaged in a live socket outlet.

The instrument is a Safety Class 1 product and therefore must be earthed. Use the supplied power cord or an appropriate replacement. Make sure that the instrument is plugged into an outlet socket with a protective earth contact.

Disconnecting device

The detachable power cord is the instrument's disconnecting device, but if the instrument is integrated into a rack or system, an external power switch or circuit breaker is required. Whatever the disconnecting device, make sure that you can reach it easily and that it is accessible at all times.

Power cords with the following terminations are available from Aeroflex. Please check with your local sales office for availability.

This equipment is provided with a 3-wire (grounded) cordset which includes a moulded IEC 320 connector for connection to the equipment. The cable must be fitted with an approved plug which, when plugged into an appropriate 3-terminal socket outlet, grounds the case of the equipment. Failure to ground the equipment may expose the operator to hazardous voltage levels. Depending upon the destination country, the colour coding of the wires will differ:

British

Country	IEC 320 plug type	Part number
United Kingdom	Straight through	23422/001
United Kingdom	Right angled	23422/002

The UK lead is fitted with an ASTA approved moulded plug to BS 1363.

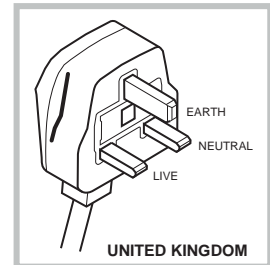

C3510

A replaceable 13 A fuse to BS 1362 is contained within the plug. This fuse is only designed to protect the lead assembly. Never use the plug with the detachable fuse cover omitted or if the cover is damaged.

The fuse(s) or circuit breaker to protect the equipment is fitted at the back of the equipment.

Country	IEC 320 plug type	Part number
North American	Straight through	23422/004
North American	Right angled	23422/005

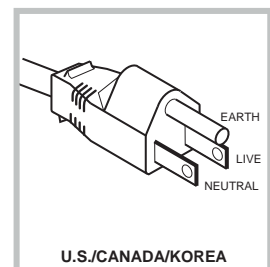

C3511

North American

Country	IEC 320 plug type	Part number
Europe	Straight through	23422/006
Europe	Right angled	23422/007

The North American lead is fitted with a NEMA 5-15P (Canadian CS22.2 No 42) plug and carries approvals from UL and CSA for use in the USA and Canada.

Continental Europe

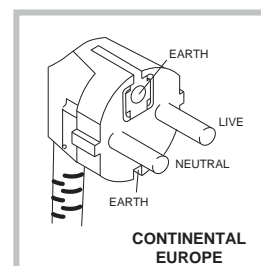

C3512

The Continental European lead is fitted with a right angle IEC83 standard C4 plug (CEE 7/7) which allows it to be used in sockets with either a male earth pin (standard C 3b) or side earth clips (standard C 2b) the latter is commonly called the German 'Schuko' plug. In common with other Schuko style plugs, the plug is not polarized when fitted into a Schuko socket. The lead carries approvals for use in Austria, Belgium, Finland, France, Germany, Holland, Italy, Norway and Sweden. Note that this plug will not fit Italian standard CEI 23-16 outlets. The lead should not be used in Denmark given that the earth connection will not be made.

Français

Le câble d'alimentation d'Europe Continentale est muni d'un connecteur mâle à angle droit type CEI83, standard C4 (CEE 7/7), qui peut être utilisé dans une prise femelle à ergot de terre (standard C 3b) ou à clips latéraux (standard C 2b), cette dernière étant communément appelée prise "Schuko" allemande. De la même façon que les autres connecteurs de type Schuko, celui-ci n'est pas polarisé lorsqu'il s'adapte à une prise femelle Schuko. Ce câble d'alimentation est homologué en Allemagne, Autriche, Belgique, Finlande, France, Hollande, Italie, Norvège et Suède. A noter que ce connecteur n'est pas compatible avec les prises de courant italiennes au standard CEI 23-16. Ce câble ne doit pas être utilisé au Danemark à cause du défaut de connexion de masse.

Deutsch

Das kontinentaleuropäische Netzkabel ist mit einem rechtwinkligen Stecker nach IEC83 C4 (CEE7/7) Standard versehen, welcher sowohl in Steckdosen mit Erde-Stift (Standard C 3b) oder seitlichen Erdeklemmen, im allgemeinen "Schukosteckdose" genannt, paßt. Üblicherweise ist der Schukostecker bei Verwendung in Schukosteckdosen nicht gepolt. Dieses Netzkabel besitzt Zulassung für Österreich, Belgien, Finnland, Frankreich, Deutschland, Holland, Italien, Norwegen und Schweden.

Hinweis: Dieser Schukostecker paßt nicht in die italienischen Standardsteckdosen nach CEI 23-16 Norm. Dieses Netzkabel sollte nicht in Dänemark verwendet werden, da hier keine Erdeverbindung hergestellt wird.

Español

El cable de alimentación tipo Europeo Continental dispone de una clavija C4 normalizada IEC83 (CEE 7/7) que permite su utilización tanto en bases de enchufe con toma de tierra macho (tipo C 3b) o con toma de tierra mediante contactos laterales (tipo C 2b) que, en este último caso, suele denominarse "Schuko". Al igual que cualquier otra clavija tipo Schuko, las conexiones a red no están polarizadas cuando se conectan a una base tipo Schuko. El cable lleva autorización para su uso en Austria, Bélgica, Finlandia, Francia, Alemania, Holanda, Italia, Noruega y Suecia. Observe que este cable no se adapta a la norma italiana CEI 23-16. El cable no debe utilizarse en Dinamarca en el caso de no efectuarse conexión a tierra.

Italiano

I cavi d'alimentazione per l'Europa continentale vengono forniti terminati con una spina ad angolo retto del tipo C4 secondo lo standard IEC83 (CEE 7/7) che può essere usato in prese in cui la terra può essere fornita o tramite connettore maschio (C 3b) o tramite clips laterali (C 2b), quest'ultima comunemente detta di tipo tedesca "Schuko". Questa spina, quando collegata ad una presa Schuko, non è polarizzata.

Il cavo può essere usato in Austria, Belgio, Finlandia, Francia, Germania, Olanda, Norvegia, Svezia ed Italia. E' da notare che per l'Italia questo non risponde allo standard CEI 23-16.

Questa spina non dovrebbe invece essere usata in Danimarca in quanto non realizza il collegamento di terra.

Power requirements

The instrument requires an AC supply in the range 100 to 240 V~, at a frequency of 50 to 60 Hz, or 108 to 118 V~ at 400 Hz. Power consumption is 200 W for 682XA instruments and 300 W for 684XA instruments. The power supply is autosensing and there is no voltage selector switch.

Before switching on ensure that the correct fuses are fitted; these are T2AL250V for 682XA series and T4AL250V for 684XA series. The fuses are located above the rear panel AC supply connector. For access to change the fuses, disconnect the supply lead and use a screwdriver to lever out the fuseholder.

Goods-in checks

The Goods-In Check verifies that the instrument is functioning correctly, but does not verify conformance to the listed specification. To verify that the instrument conforms to the specification given in Chapter 1, refer to Chapter 5, 'Acceptance testing'.

RS232 connections

Connection to the instrument's RS-232 serial interface is via the 9-way D-type connector on the rear panel.

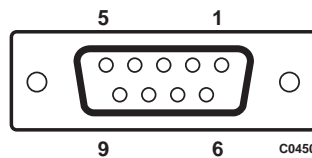

Pin		Pin	
1	Data carrier detect - DCD	6	Data set ready - DSR
2	Receive data - RX	7	Request to send - RTS
3	Transmit data - TX	8	Clear to send - CTS
4	Data terminal ready - DTR	9	Ring indicator - RI
5	Signal ground		

Fig. 2-1 RS232 connector contact assignments

To control the instrument remotely via the serial interface using a PC a NULL MODEM cable assembly is required.

GPIB connections

Connection to the instrument's GPIB interface is via the 24-way IEEE-488 Standard connector on the rear panel. A suitable GPIB lead assembly is available as an optional accessory (part number 43129/189).

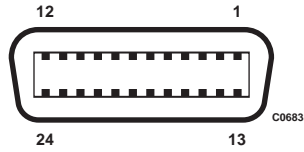

Pin		Pin	
1	Data I/O 1	13	DIO 5
2	Data I/O 2	14	DIO 6
3	Data I/O 3	15	DIO 7
4	Data I/O 4	16	DIO 8
5	EOI	17	REN
6	DAV	18	Forms twisted pair with 6
7	NRFD	19	Forms twisted pair with 7
8	NDAC	20	Forms twisted pair with 8
9	IFC	21	Forms twisted pair with 9
10	SRQ	22	Forms twisted pair with 10
11	ATN	23	Forms twisted pair with 11
12	Ground shield	24	Logic ground

Fig. 2-2 GPIB connector contact assignments

AUX connections

External connections are made via the 9-way D-type connector on the rear panel.

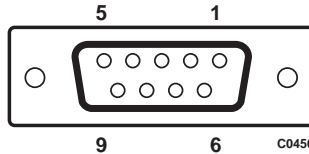

Pin		Pin	
1	Voltage output	6	Data set ready - DSR
2	Receive data - RX	7	Analogue output
3	Transmit data - TX	8	Clear to send - CTS
4	Data terminal ready - DTR	9	Signal ground
5	Signal ground		

Note 'Voltage output' is either a 0 - 10 V ramp voltage proportional to swept frequency or power, a fixed, settable DC voltage, or a DC voltage proportional to the active marker response.

'Analogue output' is the output from the spectrum analyzer log-amp (but before the video filter).

Fig. 2-3 AUX connector contact assignments

MONITOR connections

This is a 15-way D-type connector providing a standard VGA 640 x 480 colour output for an external monitor.

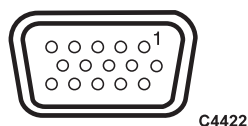

Pin		Pin	
1	RED	9	Ground
2	GREEN	10	Ground
3	BLUE	11	no connection
4	no connection	12	no connection
5	Ground (red)	13	H SYNC
6	Ground (green)	14	V SYNC
7	Ground (blue)	15	no connection
8	Ground		

Fig. 2-4 MONITOR connector contact assignments

PARALLEL PORT connections

This is a 25-way D-type connector for connecting a printer.

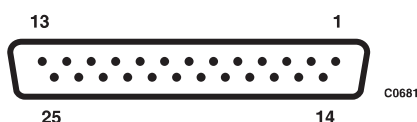

Pin		Pin	
1	STB	14	AFD
2	D0	15	ERR
3	D1	16	INIT
4	D2	17	SLIN
5	D3	18	Ground
6	D4	19	Ground
7	D5	20	Ground
8	D6	21	Ground
9	D7	22	Ground
10	ACK	23	Ground
11	BUSY	24	Ground
12	PE	25	Ground
13	SLCT		

Fig. 2-5 PARALLEL PORT connector contact assignments

Rack mounting the instrument

The 6800A may be mounted in a standard 19 inch rack using the rack mounting kit 46885/038 available as an optional accessory.

Battery replacement

The 6800A contains non-volatile memory which is powered by a lithium battery when the power is removed. Although battery life can extend to five years, this will depend on conditions of use, e.g. battery life is reduced as the temperature is increased. To avoid loss of data it is recommended that the battery is replaced every two years. Replace the battery as follows:

- (1) Ensure that the instrument is switched on; this will provide power for the non-volatile memory while the battery is replaced.
- (2) Using a coin or suitable tool, unscrew the battery compartment cover at the rear of the instrument.
- (3) Remove the battery and insert the replacement, then replace the battery compartment cover.

The replacement battery should be a SAFT LS6 or equivalent. This is a Lithium 3.5 V type, rated at 1.8 AH, size AA. A suitable replacement battery is available: part number 23711/106.

Routine maintenance

Cleaning

Before commencing any cleaning, switch off the equipment and disconnect it from the supply. The exterior surface of the case may be cleaned using a soft cloth moistened in water. Do not use aerosol or liquid solvent cleaners.

LCD

To prevent damage to the LCD window, care should be taken not to scratch the surface during use and also when cleaning. The LCD window should be cleaned by wiping a slightly damp, soft, lint-free cloth gently over the surface. To remove grease or smears, use a clean cotton cloth moistened with Heptane. No other cleaning agents should be used. Clean the window using either horizontal or vertical strokes, NEVER a circular action.

Microwave connectors

Care should be taken when using microwave connectors, both on the 6800A and any accessories that are used, such as cables, adapters, attenuators, etc. Complying with the following precautionary notes will ensure longer component life time and less equipment downtime due to connector or component failure. These measures will also help to ensure that the components will operate within specification and give repeatable results.

- The precision connectors fitted to the 6800A, and its accessories may be damaged by mating with a non-precision type. Damage to these and other connectors may occur if the connector interface parameters are not within specification. This should be checked with the appropriate gauging tool. It is strongly recommended that every connector be gauged prior to its first use and regularly thereafter, e.g. every 20 connections.
- The precise geometry of the connectors can be easily degraded by dirt and other contamination adhering to connector interfaces. Alcohol is the recommended cleaning agent, and a clean, damp cotton swab is the recommended applicator. When not in use, keep the connectors covered with the protective caps provided.
- Always use the correct mating techniques. In particular, the two connectors to be mated should be pressed together such that the pin penetrates the collet prior to the nut being tightened. Never rotate one connector body relative to the other because this wears out the mating interfaces, thus reducing connector lifetime.
- Avoid over-torquing connectors during mating, because it may damage the connector centre pin or may cause the connector body to turn in its housing.
- Avoid mechanical shock by dropping or otherwise roughly handling microwave components.

CAUTION

Routine safety testing and inspection

In the UK the 'Electricity at Work Regulations' (1989) section 4(2) places a requirement on the users of equipment to maintain it in a safe condition. The explanatory notes call for regular inspections and tests together with a need to keep records.

The following electrical tests and inspection information is provided for guidance purposes and involves the use of voltages and currents that can cause injury. It is important that these tests are only performed by competent personnel.

Prior to carrying out any inspection and tests the equipment must be disconnected from the mains supply and all external signal connections removed. All tests should include the equipment's own supply lead, all covers must be fitted and the supply switch must be in the 'ON' position.

The recommended inspection and tests fall into three categories and should be carried out in the following sequence:-

1. Visual inspection
2. Earth bonding test
3. Insulation resistance test.

1. Visual inspection

A visual inspection should be carried out on a periodic basis. This interval is dependant on the operating environment, maintenance and use, and should be assessed in accordance with guidelines issued by the Health and Safety Executive (HSE). As a guide, this equipment, when used indoors in a relatively clean environment, would be classified as 'low risk' equipment and hence should be subject to safety inspections on an annual basis. If the use of the equipment is contrary to the conditions specified, you should review the safety re-test interval.

As a guide, the visual inspection should include the following where appropriate:

Check that the equipment has been installed in accordance with the instructions provided (e.g. that ventilation is adequate, supply isolators are accessible, supply wiring is adequate and properly routed).

- The condition of the mains supply lead and supply connector(s).
- The correct rating and type of supply fuses.
- Security and condition of covers and handles.
- Check the presence and condition of all warning labels and markings and supplied safety information.
- Check the wiring in re-wireable plugs and appliance connectors.
- Check the cleanliness and condition of any ventilation fan filters.
- Check that the mains supply switch isolates the equipment from the supply.
- Check the supply indicator functions (if fitted).

If any defect is noted this should be rectified before proceeding with the following electrical tests.

2. Earth bonding tests

Earth bonding tests should be carried out using a 25 A (12 V maximum open circuit voltage) DC source. Tests should be limited to a maximum duration of 5 seconds and have a pass limit of 0.1 Ω after allowing for the resistance of the supply lead. Exceeding the test duration can cause damage to the equipment. The tests should be carried out between the supply earth and exposed case metalwork, no attempt should be made to perform the tests on functional earths (e.g. signal carrying connector shells or screen connections) as this will result in damage to the equipment.

3. Insulation tests

A 500 V DC test should be applied between the protective earth connection and combined live and neutral supply connections with the equipment supply switch in the 'on' position. It is advisable to make the live/neutral link on the appliance tester or its connector to avoid the possibility of returning the equipment to the user with the live and neutral poles linked with an ad-hoc strap. The test voltage should be applied for 5 seconds before taking the measurement.

Aeroflex employs reinforced insulation in the construction of its products and hence a minimum pass limit of 7 M Ω should be achieved during this test.

Where a DC power adapter is provided with the equipment the adapter must pass the 7 M Ω test limit.

We do not recommend dielectric flash testing during routine safety tests. Most portable appliance testers use AC for the dielectric strength test which can cause damage to the supply input filter capacitors.

4. Rectification

It is recommended that the results of the above tests are recorded and checked during each repeat test. Significant differences between the previous readings and measured values should be investigated.

If any failure is detected during the above visual inspection or tests, the equipment should be disabled and the fault should be rectified by an experienced Service Engineer who is familiar with the hazards involved in carrying out such repairs.

Safety critical components should only be replaced with equivalent parts, using techniques and procedures recommended by Aeroflex.

The above information is provided for guidance only. Aeroflex designs and constructs its products in accordance with International Safety Standards such that in normal use they represent no hazard to the operator. Aeroflex reserves the right to amend the above information in the course of continuing its commitment to product safety.

Putting into storage

If the instrument is to be put into storage, ensure that the following conditions are maintained:

Temperature range	-40 to +71°C
Humidity	Less than 93% at 40°C

Chapter 3

LOCAL OPERATION

Contents

Introduction	3-7
Front panel features	3-7
Rear panel features	3-10
Front panel keys and soft key menus.....	3-11
Summary of key functions.....	3-12
Numeric entry.....	3-15
Text entry	3-16
Channel coupling.....	3-17
Display.....	3-18
Channels and measurements.....	3-18
Display features.....	3-18
Trace information area	3-19
X-domain information.....	3-22
Spectrum analyzer receiver parameters.....	3-23
General information area.....	3-24
Error messages.....	3-24
Using markers.....	3-24
Marker functions	3-25
Limit checking.....	3-26
Creating hard copy	3-27
Using a printer.....	3-27
Using MIPlot.....	3-27
Data storage.....	3-28
Saving traces to removable storage	3-28
Copying data between an internal store and removable storage.....	3-29
Using the 6800A as a stand-alone source.....	3-29
Using an external keyboard	3-30
International settings	3-30
Using applications	3-31
Password protection.....	3-31
Primary password.....	3-31
User-defined passwords	3-32
Unauthorised use protection.....	3-32
Store overwrite protection.....	3-32
Entering a new password.....	3-32
Installing a printer.....	3-33
Initial setup	3-33
Introduction	3-34
Backend selection.....	3-34
Local port selection	3-35
USB printer	3-35
Parallel printer	3-35
Printer model selection	3-35
Driver selection	3-36
Printer test	3-36
Banner selection	3-36
Printer quota settings	3-37
Users access settings	3-37
General information	3-37
Confirmation	3-38
Substituting a printer with another of the same model.....	3-38
Removing a printer	3-39
Setting up the LCD.....	3-41

LOCAL OPERATION

Setting the real time clock	3-41
Remote operation.....	3-41
Making measurements	3-41
Precautions	3-41
Switching on.....	3-42
Scalar measurements	3-42
Source control	3-43
Measurement definition.....	3-44
Scalar inputs	3-44
Using the spectrum analyzer input.....	3-45
Conversion measurements.....	3-45
Group delay measurements	3-45
Calibration.....	3-46
Fault location measurements	3-47
Transmission line database.....	3-47
Fault location calibration.....	3-48
Fault location features	3-48
Spectrum analyzer measurements	3-48
Spectrum analyzer controls	3-48
Coupling of parameters	3-49
Other useful features	3-49
Normalisation	3-50
General measurement procedure	3-50
DISPLAY GROUP KEYS	3-51
[SELECT MEAS] key	3-51
[SWITCH CHANNEL] key	3-51
[DISPLAY] key	3-51
Display	3-52
CHANNEL MODE GROUP KEYS	3-53
[SCALAR] key	3-53
Scalar.....	3-54
Input Selection	3-56
Tuned Input.....	3-57
Conversion Meas (Frequency sweep)	3-58
Conv Meas	3-59
External Src.....	3-61
Select Src.....	3-61
Mixer Meas	3-62
Advanced Set-up (Frequency sweep)	3-64
Conversion Meas (Power sweep)	3-65
Advanced Set-up (Power sweep)	3-65
Group Delay.....	3-66
Zeroing	3-67
Averaging.....	3-68
Smoothing	3-69
Lim Checking.....	3-70
Assign Lim Spec	3-71
Limit Editor.....	3-72
Limit Type.....	3-73
Edit Segments	3-74
Save Spec As.....	3-75
Select Spec	3-76
Print Lim Spec	3-77
X-axis Annot.....	3-78
Input Set-up.....	3-79
I/p Level Offsets.....	3-80
Input A (B or C) Corr	3-81

LOCAL OPERATION

[FAULT LOCATION] key	3-89
Fault Loc	3-90
Config Meas	3-92
Tx Line Dbase	3-95
Select Subset	3-97
Menu	3-98
Tx Line Store	3-99
Averaging	3-100
Windowing	3-101
Zoom Mode	3-102
Dbase Funcs	3-103
Cpy from Dbase	3-104
Tx Line Dbase	3-105
Select Store	3-106
Edit Store	3-107
Save Store	3-108
Tx Line Store	3-109
Edit Attn Table	3-110
Select Store	3-111
Tx Line Store	3-111
[SPECTRUM] key	3-119
Spectrum	3-120
Peak Hold	3-123
Demodulation	3-123
Coupled Funcs	3-124
X-axis Annot (Rx or Tracking Generator selected)	3-126
X-axis Annot (User Set selected)	3-127
External Mixer	3-128
SETUP & ANALYSIS GROUP KEYS (Scalar Channel).....	3-131
[SOURCE] key	3-131
Source (Start/Stop Frequency Sweep Mode)	3-132
Source (Centre/Span Frequency Sweep Mode)	3-134
Source (CW Mode)	3-135
FM	3-136
Source (Power Sweep)	3-137
Sweep Time	3-138
Source Mode	3-139
Levelling	3-140
Freq Standard	3-141
Voltage O/P	3-142
Loop Bandwidth	3-143
Pulse Mod	3-144
Single Pulse	3-145
Single Pulse	3-146
Trigger Mode	3-148
[CAL] key	3-151
Cal	3-152
Through	3-153
Path Cal	3-154
Short & Open	3-155
Short or Open	3-155
S/E Ins Loss	3-156
Apply Path Cal	3-157
[SCALE / FORMAT] key	3-161
Scale / Format	3-162
Autoscaling	3-163
[MARKER] key	3-164
Marker	3-165

LOCAL OPERATION

Max/Min.....	3-167
Pk - Pk (Scalar / Tuned Input).....	3-168
Pk - Pk (Group Delay).....	3-169
Deviation.....	3-170
Mkr Funcs.....	3-171
Search.....	3-172
Bandwidth.....	3-173
Delta Marker.....	3-175
Set Up Mkrs.....	3-176
SETUP & ANALYSIS GROUP KEYS (Fault Location Channel)	3-179
[SOURCE] key.....	3-179
Source.....	3-180
[CAL] key.....	3-183
Cal.....	3-184
Fault Loc Cal.....	3-185
[SCALE / FORMAT] key.....	3-186
Scale / Format.....	3-187
[MARKER] key.....	3-188
Marker.....	3-189
Peak Level.....	3-191
Delta Marker.....	3-191
SETUP & ANALYSIS GROUP KEYS (Spectrum Analyzer Channel)	3-195
[SOURCE] key.....	3-195
Source (CW selected).....	3-196
Source (Tracking Generator selected).....	3-198
Source (Offset Tracking Generator selected).....	3-199
Scale and Offset.....	3-200
[CAL] key.....	3-203
Cal.....	3-204
Normalise.....	3-204
[SCALE / FORMAT] key.....	3-205
Scale / Format.....	3-206
[MARKER] key.....	3-208
Marker.....	3-209
Peak Search Fns.....	3-211
Delta Marker.....	3-211
Mkr Funcs.....	3-212
SETUP & ANALYSIS GROUP KEYS (Common)	3-215
[PRINT] key.....	3-215
Print.....	3-216
Print Options.....	3-217
Save Options.....	3-219
Recall Options.....	3-220
Print File.....	3-221
Select Printer.....	3-222
Confirm Print.....	3-223
[SAVE / RECALL] key.....	3-227
Save/Recall.....	3-228
Save Trace.....	3-229
Set Store Info.....	3-230
Recall Trace.....	3-231
Apply Trace Mem.....	3-232
Save Settings.....	3-233
Recall Settings.....	3-234
View Settings.....	3-235
Select Store.....	3-236

SYSTEM GROUP KEYS	3-241
[RUN APPS] key.....	3-241
Run Apps	3-242
[UTILITY] key.....	3-243
Utility	3-243
Remote	3-244
Titles.....	3-245
Security	3-246
Set Passwords.....	3-246
Inc/Dec Steps	3-247
Store Mngmnt	3-248
Manage Stores.....	3-249
Service.....	3-251
Set-up	3-252
Display	3-253
Colour Palettes	3-253
Date & Time.....	3-254
Status.....	3-255
Instrument Cals	3-256
RF Source Cals.....	3-257
Bband Power Cal	3-258
Select Store	3-258
Nband Power Cal	3-259
Power Cal Funcs	3-260
Spec Ana Cals	3-261
Tests	3-262
Test Display	3-262
Diagnostics.....	3-263
International	3-264
New Locale	3-265
Applications	3-266
Install App.....	3-267
Remove App	3-267
Auto Run.....	3-268
[LOCAL] key	3-279
[PRESET] key	3-280
Preset.....	3-280
[SOURCE ON/OFF] key.....	3-281

List of figures

Fig. 3-1 6800A front panel	3-9
Fig. 3-2 6800A rear panel.....	3-10
Fig. 3-3 6800A display features	3-18
Fig. 3-4 Trace information area (scalar / fault location).....	3-19
Fig. 3-5 Trace information area (spectrum analyzer)	3-21
Fig. 3-6 X-domain information	3-22
Fig. 3-7 Spectrum analyzer receiver information	3-23
Fig. 3-8 General information area	3-24
Fig. 3-9 Limit lines for bandpass filter testing	3-26
Fig. 3-10 DISPLAY menu.....	3-51
Fig. 3-11 Effect of averaging on a trace	3-68
Fig. 3-12 Effect of smoothing on a trace	3-69
Fig. 3-13 Limit checking specification form	3-72
Fig. 3-14 SCALAR menus (sheet 1)	3-83

LOCAL OPERATION

Fig. 3-15 SCALAR menus (sheet 2)	3-85
Fig. 3-16 SCALAR menus (sheet 3)	3-87
Fig. 3-17 Effect of masking correction on a fault location measurement.....	3-90
Fig. 3-18 Configuring a fault location measurement.....	3-92
Fig. 3-19 Effect of data windowing on a fault location measurement.....	3-101
Fig. 3-20 FAULT LOCATION menus (sheet 1).....	3-113
Fig. 3-21 FAULT LOCATION menus (sheet 2).....	3-115
Fig. 3-22 FAULT LOCATION menus (sheet 3).....	3-117
Fig. 3-23 SPECTRUM menus.....	3-129
Fig. 3-24 Source-only mode display.....	3-133
Fig. 3-25 SOURCE menus - scalar channel	3-149
Fig. 3-26 CAL menus - scalar channel.....	3-159
Fig. 3-27 SCALE / FORMAT menu - scalar channel	3-161
Fig. 3-28 Bandwidth measurement of a band-pass filter.....	3-174
Fig. 3-29 MARKER menus - scalar channel	3-177
Fig. 3-30 SOURCE menus - fault location channel	3-181
Fig. 3-31 CAL menus - fault location channel	3-183
Fig. 3-32 SCALE / FORMAT menu - fault location channel	3-186
Fig. 3-33 MARKER menus - fault location channel	3-193
Fig. 3-34 SOURCE menus - spectrum analyzer channel.....	3-201
Fig. 3-35 CAL menus - spectrum analyzer channel	3-203
Fig. 3-36 SCALE/FORMAT menu - spectrum analyzer channel.....	3-205
Fig. 3-37 MARKER menus - spectrum analyzer channel	3-213
Fig. 3-38 PRINT menus	3-225
Fig. 3-39 SAVE/RECALL menus (sheet 1).....	3-237
Fig. 3-40 SAVE/RECALL menus (sheet 2).....	3-239
Fig. 3-41 RUN APPS menu.....	3-241
Fig. 3-42 UTILITY menus (sheet 1)	3-269
Fig. 3-43 UTILITY menus (sheet 2)	3-271
Fig. 3-44 UTILITY menus (sheet 3)	3-273
Fig. 3-45 UTILITY menus (sheet 4)	3-275
Fig. 3-46 UTILITY menus (sheet 5)	3-277
Fig. 3-47 PRESET menu	3-280

Introduction

This chapter explains how to operate the 6800A Series of instruments using the front panel controls and soft key menus. The first part of the chapter provides illustrations and descriptions of the front panel features, the rear panel features and connectors, and the display. This is followed by a general description of the types of measurement that can be made with the 6800A, and descriptions of the main operating features. The remainder of the chapter describes the menus in detail. For examples of how the instrument can be used to make a wide variety of measurements, refer to the supplied 'Getting Started' manual.

Descriptions, soft key selections and illustrations cover all instrument versions and options; those that are not applicable to a particular instrument can be disregarded.

Conventions

The following conventions are used in this chapter:

CAPS	Capitals are used to identify names of controls and panel markings, or system functions where no direct reference to an associated key is intended.
[CAPS]	Capitals in square brackets indicate hard key titles.
[<i>Italics</i>]	Italics in square brackets indicate soft key titles.
[<i>Averaging</i> ●]	A ● after a soft key title indicates that the key has a toggle action, and that the function is enabled.
[<i>Averaging</i> ○]	A ○ after a soft key title indicates that the key has a toggle action, and that the function is disabled.

Front panel features

- ① **SUPPLY switch** This key is used to activate the instrument if it is in standby mode; pressing the key again returns it to standby mode (AC power to the instrument is controlled by a rear panel switch).
- ② **System Group keys** This key group comprises the [RUN APPS], [UTILITY], [LOCAL], [PRESET] and [SOURCE ON/OFF] keys. They are used for running 6800A application programs, presetting the instrument, controlling the RF output and provide various system functions.
- ③ **Display Group keys** This key group comprises the [DISPLAY], [SELECT MEAS] and [SWITCH CHANNEL] keys. They determine the number of channels and measurements that are displayed, and which channel or measurement is active.
- ④ **Liquid crystal display** This is used for display of measurement traces and annotations, soft key labels and other information. The display is divided into specific information areas, explained in detail later in this chapter.
- ⑤ **Soft keys** The eight soft keys are used to select the desired control and functional options presented by the various menus accessed through the dedicated function keys on the front panel.
- ⑥ **Channel Mode Group keys** This key group comprises the [SPECTRUM], [SCALAR] and [FAULT LOCATION] keys. They determine the channel type and enable the measurement to be set up. (The [SPECTRUM] key applies only to the 6840A versions.)

LOCAL OPERATION

- ⑦ **Setup & Analysis Group keys** This key group comprises the [SOURCE], [CAL], [SCALE / FORMAT], [MARKER], [SAVE / RECALL] and [PRINT] keys. They are used for controlling the synthesized source, calibrating the measurement system, scaling and formatting the display, setting up markers, creating hard copy and saving/recalling measurements and instrument settings.
- ⑧ **Numeric entry and terminator keys** These keys are used for entering values of numeric parameters and other numeric entries.
- ⑨ **USB ports** For removable storage and/or printer.
- ⑩ **SIGNAL SOURCE OUTPUT connector** This is a precision microwave connector for the RF output signal generated by the synthesized source.
- ⑪ **Rotary control** Used for adjusting marker positions and parameter values.
- ⑫ **SPECTRUM ANALYZER INPUT connector** This is a precision microwave connector for the spectrum analyzer receiver input (6840A versions only).
- ⑬ **Step keys** The step keys (\uparrow and \downarrow) are used to step the current value of a parameter up or down.
- ⑭ **EXT MIXER connector** Enables an external mixer to be used for spectrum analyzer measurements instead of the instrument's own mixer (6840A versions only).
- ⑮ **VOLUME control** This controls the volume of the loudspeaker output when the demodulation facility is being used (6840A versions only).
- ⑯ **Input connectors** INPUT A, INPUT B and INPUT C accept 12 pin connectors from the detector cable assemblies.

LOCAL OPERATION

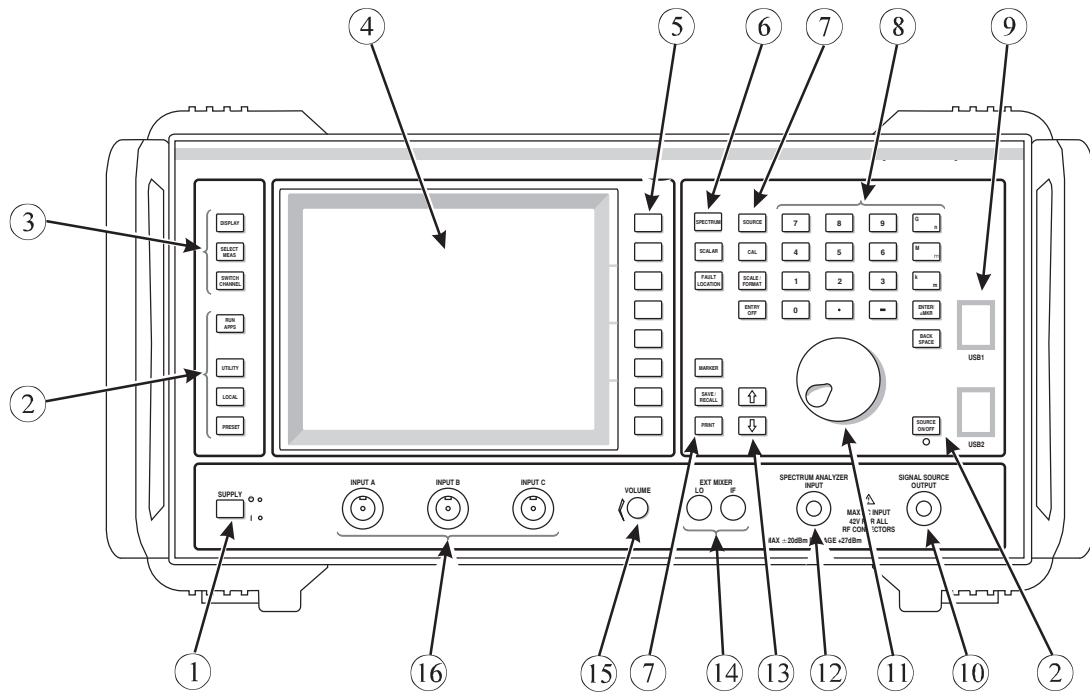

6840A series

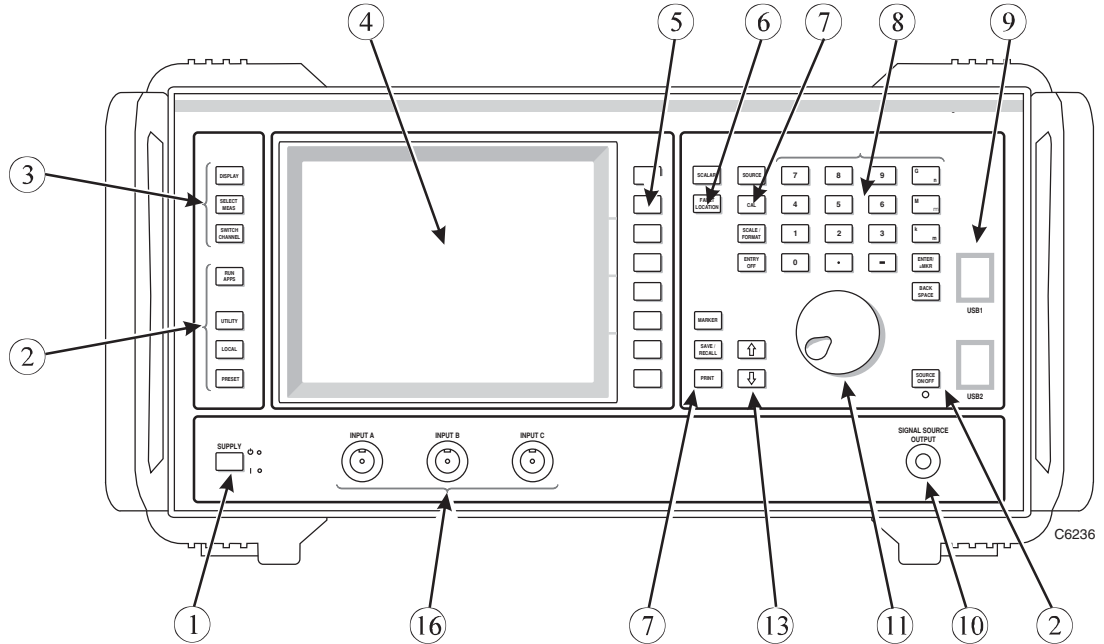

6820A series

Fig. 3-1 6800A front panel

Rear panel features

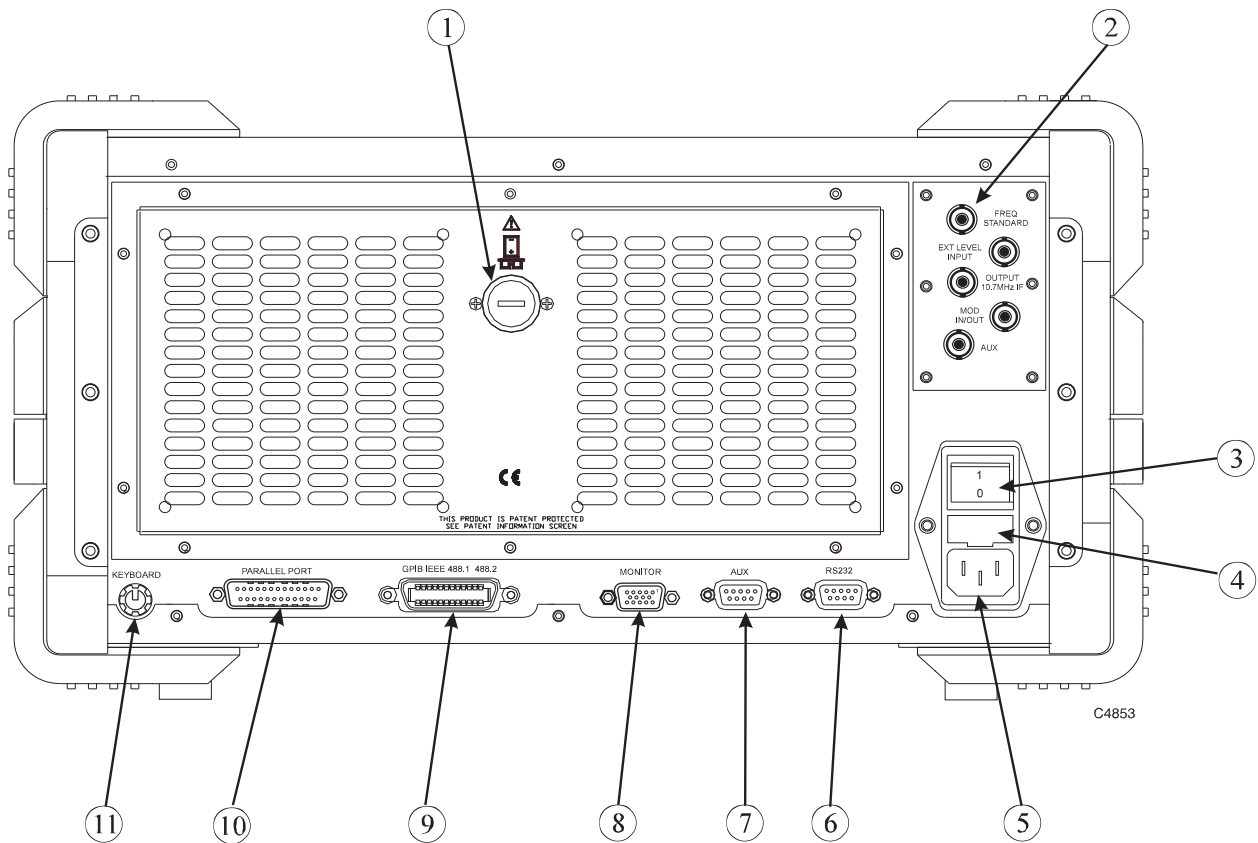

Fig. 3-2 6800A rear panel

- ① **Battery compartment cover** Removal of this cover provides access to the Lithium battery that is used to power the instrument's non-volatile memory.
- ② **FREQ STANDARD connector** A BNC connector that provides a 10 MHz output derived from the internal frequency standard, or accepts a 1 or 10 MHz input from an external standard (as selected from the Freq Standard menu, page 3-141).
- EXT LEVEL INPUT connector** A BNC connector that enables the connection of a remote detector or power meter output for source levelling.
- OUTPUT 10.7MHz IF connector** A BNC connector that provides the 10.7 MHz IF output from the spectrum analyzer (6840A versions only).
- MOD IN/OUT connector** A BNC connector that accepts a suitable signal for modulating the source, or outputs the internally generated modulating signal (if the Group Delay or Internal FM option is fitted).
- AUX connector** A BNC connector that provides a SYNC OUT signal (Option 23) to an external pulse modulator, or receives a TRIG IN signal to drive an internal pulse modulator (Option 25).
- ③ **AC power switch** Controls the AC power to the instrument (the instrument is switched between standby and operating modes using the front panel SUPPLY switch).
- ④ **Fuse compartment cover** Provides access to the AC supply fuses (T2AL250V for 6820A series; T4AL250V for 6840A series).

- ⑤ **AC power connector** A 3-pin connector that mates with the supplied AC supply cable.
- ⑥ **RS232 connector** A 9-way D-type connector that allows connection to a controller/modem for remote operation of the instrument. Refer to the Remote Operating Manual for information on RS-232 operation.
- ⑦ **AUX connector** A 9-way D-type connector that provides two signals: (1) A voltage output that is either a 0 - 10 V ramp voltage proportional to swept frequency or power, a fixed, settable DC voltage, or a DC voltage proportional to the active marker response. (2) The output from the spectrum analyzer log-amp (but before the video filter).
- ⑧ **MONITOR connector** A 15-way high density D-type connector that allows connection of a standard VGA colour monitor.
- ⑨ **GPIB connector** A 24-way GPIB connector that connects the instrument to an external controller when it is to be controlled through the GPIB. Refer to the Remote Operating Manual for information on GPIB operation.
- ⑩ **PARALLEL PORT connector** A 25-way D-type connector that is used to connect a suitable printer via the Centronics interface.
- ⑪ **KEYBOARD connector** A standard 6-way mini-DIN connector that allows connection of an IBM-compatible keyboard.

Front panel keys and soft key menus

The functions of the 6800A are activated from the front panel by the operator using specific function keys (hard keys), eight soft keys for accessing menu options, a numeric entry key group, a rotary control and step up/down keys.

Note

In this manual all front panel keys are shown in brackets, e.g. [SOURCE]; soft key labels are shown in brackets in lower case italic type, e.g. [*Source Mode*].

Some of the more important terms relating to the operation of the instrument are defined below:

Input. A front panel connector (INPUT A, B or C) to which is connected a scalar detector.

Channel. An area on the screen where measurements are displayed; the 6800A can display one or two channels.

Measurement. A trace within a channel; the 6800A can display one or two measurements per channel.

Channel mode. Determines the type of measurements that the channel displays, i.e. Scalar, Fault Location or Spectrum Analyzer.

Channel coupling. Coupled channels share the same source setup; when uncoupled, they can have independent source set-ups. Channels can only be coupled if they are the same type.

Active channel. The channel containing the currently active measurement.

Active measurement. A measurement's attributes may be changed when it is active.

The hard keys can be grouped into related functions, and a brief outline of their functions is given below:

Summary of key functions

DISPLAY group

- [DISPLAY] Enables selection of single or dual channel display, and which measurements within a channel are to be displayed.
- [SELECT MEAS] Cycles around all the displayed measurements, making each active in turn.
- [SWITCH CHANNEL] Switches to the other channel, making it active.

CHANNEL MODE group

- [SCALAR] Configures the 6800A to make scalar measurements. If the channel is not already scalar, pressing this key defines it as a scalar channel containing measurement 1 (with channel specific parameters set to default values).
- Configure inputs** to measure absolute power or a power ratio, or the **tuned input** mode can be used where the spectrum analyzer receiver is used in place of a detector for frequency selective power measurements.
- Use the **conversion measurements** facilities to make measurements on frequency conversion devices. Functions are provided that enable the frequency displayed on the x-axis to be scaled/offset from the source frequency for these measurements. Power conversion devices such as amplifiers can similarly be measured, by displaying a power sweep range that is offset from the source power range.
- For systems where a linear phase/frequency response is important, **group delay** measurements can be performed.
- Input offsets** can be applied, and AC or DC **detection mode** selected.
- Correction** can be applied to compensate for non-ideal detector characteristics (using detector EEPROM data).
- Limit checking** can be applied, whereby the measurement is compared against upper and lower complex limit lines, defined by the user.
- Apply **averaging** and **smoothing** to reduce trace noise and ripple.
- [FAULT LOCATION] Configures the 6800A to make fault location measurements. If the channel is not already fault location, pressing this key defines it as a fault location channel containing measurement 1 (with channel specific parameters set to default values).
- Transmission line parameters can be entered directly, or can be set up automatically from a **transmission line database** record. Functions are provided for searching, copying records to 6800A stores, and storing data for transmission lines not included in the database.
- Most of the functions described above for a scalar channel are provided (**input offsets**, **detection mode**, **detector correction**, **averaging** and **limit checking**), but with the following additions:
- Windowing** - reduces side lobes associated with the main peak on the display.
- Masking correction** - corrects for amplitude errors.
- Zoom mode** - allows part of the display range to be magnified.

- [SPECTRUM]** Configures the 6800A to make spectrum analyzer measurements (only applies to 6840A series instruments). If the channel is not already spectrum analyzer, pressing this key defines it as a spectrum analyzer channel containing measurement 1 (with channel specific parameters set to default values).
- Set up the spectrum analyzer **receiver parameters** (e.g. frequency range, resolution bandwidth, video bandwidth).
- Signal tracking** can be enabled to prevent the signal going outside the sweep range during narrow-band sweeps.
- The **demodulation** facility allows the display of FM demodulated signals.
- Limit checking** can be applied and the **x-axis annotation** specified.

SETUP & ANALYSIS group

- [SOURCE]** Provides control of the synthesized sweep generator.
- Scalar channel:*
- Select **source mode** (CW or sweep), and set up **sweep parameters**.
 - Select the **levelling mode** that is used to control the output power.
 - Select the **frequency standard** used by the synthesized source.
 - Provides control of the programmable **voltage output** (AUX connector).
- Fault location channel:*
- The functions provided are similar to those of a scalar channel, except that the source mode is not user-definable, and the source frequency range is set via the [FAULT LOCATION] key.
- Spectrum analyzer channel:*
- Enables the source to be set to CW or to be used as a tracking generator, i.e. set to the frequency range of the spectrum analyzer receiver (with optional offset / scaling).
- [CAL]** Enables system errors to be removed prior to a measurement, and detectors to be zeroed.
- [SCALE / FORMAT]** Enables the size and placement of the trace on the graticule to be adjusted, and selection of the units in which the measurement is displayed.
- [MARKER]** Provides access to various marker functions, which allow the measurement to be examined in greater detail (e.g. max/min, peak-peak, search, bandwidth). The marker table can also be turned on/off.
- [SAVE / RECALL]** Enables measurement traces and instrument settings to be saved or recalled, using either internal stores or removable storage. Provides a facility for making measurements relative to a stored trace.
- [PRINT]** Accesses the hard copy functions of the 6800A. Hard copies of all measurements can be created using a suitable printer. A printer can also be used to print out textual data, such as limit specifications and instrument settings stores.

SYSTEM group

[RUN APPS]	Used to select and run application programs, which have previously been installed from removable storage.
[UTILITY]	Provides access to instrument setup and service functions: <ul style="list-style-type: none">Enter main screen and measurement titles.Set user passwords.Define the step size used by the step up/down keys.Configure instrument for a particular country.Install application programs.Set up instrument for remote (GPIB or RS-232) operation.Set up the LCD and real time clock.Instrument store management.Display/keyboard tests.Examine power-on test results.Instrument calibrations.
[LOCAL]	Used to return the instrument to local (front panel) operation after being put into remote mode.
[PRESET]	Returns the instrument to its default set-up conditions, or to settings defined by the user.
SOURCE ON / OFF	Turns the source on and off.

The function currently activated is called the *active function*. As long as a function is active it can be modified with the numeric entry controls (explained later). A function remains active until either another function is selected, [ENTRY OFF] is pressed, or the appropriate soft key is pressed that is provided for this purpose.

Front panel keys are used to change instrument functions directly or to provide access to additional functions available in soft key menus. These menus are displayed lists of related functions or choices for a particular function, with each choice corresponding to one of the eight soft keys located to the right of the LCD. Pressing one of the soft keys either executes the labelled function and makes it the active function, or changes the current status of a function, or presents another set of menu labels. The type of action is indicated by the shape of the box enclosing the soft key label, as follows:



Indicates that selecting the soft key will immediately cause the instrument to perform the designated function, without any further action from the user.

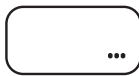

Indicates that, after selecting this soft key, the user will be able to change a parameter. A dialogue box will be displayed on the screen containing a title indicating the parameter being changed, and an input field for entering the new value.



Indicates that selecting this soft key will toggle the indicated item on or off. The box contains a representation of an indicator lamp which 'lights up' to indicate that the item is on.



If the top and bottom edges are highlighted, this indicates that, out of two or more possible items, this one has been selected. Pressing it will have no effect, but selecting another in the same group will deselect it. The boxes representing soft keys in the same group are linked together by a vertical line.

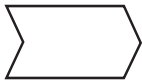

Indicates that selecting this soft key will present the user with either a new menu or a dialogue box. The dialogue box is a window displayed on the screen to allow users to change one or more parameters which make up the entries in the form. The soft keys are used to select, change add or delete parameters, and various other operations according to the function involved.

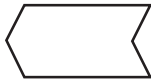

This is always the bottom soft key of a menu, and is the 'return' key that returns the user to the previous level of the menu structure.



Unselectable items are indicated by a dotted outline.

Top level menus, i.e. the ones displayed when a hard key is pressed, are indicated by surrounding the menu title with a box outline.

Most menus allow access to other top level menus simply by pressing the appropriate hard key. The user does not need to return to the top level menu from which the current one is derived. The exceptions to this are menus to do with editing, where the user must return to the top level menu by pressing the appropriate return soft keys.

Detailed descriptions of all the 6800A menus are given later in this chapter.

The menu structure associated with the some of the keys will depend upon the active channel type. For example, the [SOURCE] key menu depend on whether the active channel is scalar, fault location or spectrum analyzer.

At the start of each menu description is shown the path for that menu, i.e. the key presses the operator must make in order to access the menu. The menu title and soft key labels are listed on the left hand side of the page, exactly as they would be shown on the display. The right hand column contains the descriptions.

Numeric entry

The numeric keypad, rotary control and step keys are used in conjunction with other front panel keys and soft keys to modify the active entry, to enter or change numeric data, and to change the domain value (i.e. x-axis position) of the active marker. In many cases, the keypad, rotary control and step keys can be used interchangeably. In some cases a parameter can be set from the active and delta markers displayed on the active measurement.

Before a function can be modified it must be made the active function by pressing a front panel key or soft key. It can then be modified directly with the step keys or rotary control, or the new value can be entered on the numeric keypad and followed by a terminator as described below.

Numeric keypad. Used to enter digits, decimal point and minus sign for numeric entries, followed by a units terminator.

Units terminator keys. These are the four keys to the right of the numeric keypad. They are used to specify the units for numeric entries from the keypad, and at the same time terminate the entries. A numeric entry is incomplete until a terminator is supplied. Some functions, for example where only a single digit entry is required, do not require a terminator. The units are abbreviated on the terminator keys as follows:

G_n	Giga / Nano ($10^9 / 10^{-9}$)
M_μ	Mega / Micro ($10^6 / 10^{-6}$)
k_m	kilo / milli ($10^3 / 10^{-3}$)
ENTER / =MKR	basic units such as Hz, Volts etc.; unitless entries, such as Averaging Number.

Functions can be terminated with any of the above terminator keys. The first three keys represent both positive and negative powers of ten, but the power represented by a particular terminator key at any given time is context dependent. That is, the parameter being changed determines whether positive or negative powers of ten apply (e.g. positive powers apply for frequency, and negative powers for voltage).

Some parameters which have a particularly wide range will default to either positive or negative powers of ten, but may be changed by pressing [-] before pressing a terminator key. For example, power in Watts defaults to negative powers of ten (n, μ , m), but positive powers (G, M, k) can be achieved by first pressing [-] before terminating the numeric entry.

Within the menu descriptions, each function requiring numeric entry will indicate the valid terminator by use of the following conventions:

10⁺ indicates positive powers of ten, including the [ENTER / =MKR] key.

10⁻ indicates negative powers of ten, including the [ENTER / =MKR] key.

Any indicates that any terminator key can be used.

A checklist box is used to indicate which terminators apply for numeric entry, and also whether the step keys, rotary control or “= marker” can be used. An example is shown below:

Rotary Control	<input checked="" type="checkbox"/>	Step Keys	<input checked="" type="checkbox"/>	=Marker	<input checked="" type="checkbox"/>	Numeric Pad	<input checked="" type="checkbox"/>	Terminator	<input checked="" type="checkbox"/>	10 ⁺
----------------	-------------------------------------	-----------	-------------------------------------	---------	-------------------------------------	-------------	-------------------------------------	------------	-------------------------------------	-----------------

Rotary control. This is used to make continuous adjustments to current values for various functions. The sensitivity and rate of parameter update depends on the parameter being controlled. If the active marker is turned on, and no other function is active, the control can be used to adjust the marker domain value (x-axis position). Values changed by the rotary control are effective immediately, and require no units terminator. The control can also be used to move horizontally between input fields on the displayed forms of certain menus.

Step keys (\uparrow and \downarrow). These are used to step the current value of the active function up or down. The step size can be independently set for various parameter types, such as frequency, power and voltage, by accessing the Inc/Dec Steps menu, accessed via the [UTILITY] key. The keys autorepeat when held down. The step keys can also be used to move vertically between input fields on the displayed forms of certain menus.

[ENTRY OFF]. When a numeric entry has been terminated with one of the units keys, the display is updated to reflect the new value. However, the numeric entry form remains to allow the parameter to be further modified, if required. Pressing [ENTRY OFF] removes the form, as well as any displayed prompts, error messages or warnings.

[BACK SPACE]. Deletes the last digit entered from the numeric keypad.

Parameter entry via marker. Some parameters can be set from the position or response values of the active or delta markers displayed on the active measurement. This is done by positioning the marker, pressing the soft key for the parameter, then pressing [ENTER / =MKR] on the numeric keypad. Parameters that can be set in this way have the ‘=Marker’ item ticked in its checklist box.

Using numeric keys for store and file selection

When a store (or file) has to be selected a list of the appropriate stores will be presented with an index number beside each entry. In addition to using the step keys (\uparrow and \downarrow) to select the store, the index number may be entered using the numeric keypad and terminated with the [ENTER / =MKR] key.

Text entry

Many of the 6800A functions require the entry of text, for example when entering store and file names, screen and measurement titles and descriptive text for stores. When text entry is required, a form is displayed containing an input field and four rows of characters arranged as follows:

Set Screen Title
Microwave System Analyzer_____
a b c d e f g h I j k l m n o p q r s t u v w x y z
à á â ã ä å æ ç è é ê ë ì í î ï ð ñ ò ó ô õ ö ø ù ú û ü ý ÿ þ
0 1 2 3 4 5 6 7 8 9 ! " # \$ % & ' () * + , - . /
: ; < = > ? [\] ^ _ { } ~ £ µ

The character that is to be selected is enclosed by a box which can be moved along the rows of characters using the rotary control. The step keys are used to select the required row. The front panel keys 0 to 9, "." and "-" can be used directly.

For entry of store/file names and screen/measurement titles, the following soft keys are displayed:

<i>[Select Character]</i>	Adds the selected character to the input field at the cursor position.
<i>[Space]</i>	Adds a space character to the text input at the cursor position.
<i>[Caps Lock]</i>	Toggles caps lock on and off.
<i>[Cursor Left]</i>	Moves the cursor left one character.
<i>[Cursor Right]</i>	Moves the cursor right one character.
<i>[Delete Character]</i>	Deletes the character at the cursor position.
<i>[Erase Text]</i>	Removes all the text from the input field.
<i>[Done]</i>	Terminates text entry.

Some functions allow longer text strings to be entered or edited, such as descriptive text for stores. In these cases, *[Cursor Left]* and *[Cursor Right]* appear on a sub-menu together with additional soft keys for moving the cursor quickly through the input field: *[Word Left]*, *[Word Right]*, *[Start of Text]* and *[End of Text]*.

Text entry can also be achieved using an external IBM PC keyboard connected to the rear panel KEYBOARD connector of the instrument. An external keyboard can also be used instead of the front panel to control all the instrument functions (see 'Using an external keyboard', page 3-30)

Channel coupling

In many applications, there may be a requirement that the RF source set-up (and the voltage output available at the AUX connector) be the same for both channels. This can be achieved by setting channel coupling on from the Display menu. When channels are coupled, the instrument will ensure that the RF source and voltage output are set up identically for both channels.

When channel coupling is first switched on, the RF source and voltage settings defined for the active channel will be duplicated for the other channel. Afterwards, any changes made to the source or voltage output on the active channel will be reflected in the other channel.

Should it be necessary to have independent source set-ups for each channel, channel coupling can be switched off. Channels can only be coupled if they are the same type. Following an instrument PRESET, channel coupling is on for 6820A series instruments and off for 6840A series instruments.

Display

Channels and measurements

The 6800A has two channels for independent measurement and display of data. Two different measurements can be displayed simultaneously on the same channel, for example insertion loss and return loss of a device. A channel can be defined to be either a scalar channel, a fault location channel or a spectrum analyzer channel by using the [SCALAR], [FAULT LOCATION] or [SPECTRUM] keys respectively. Once a channel has been defined for one of these measurement types, the [SOURCE], [CAL], [SCALE/FORMAT] and [MARKER] keys will provide the appropriate menus for setting up the measurement. Up to two traces can be displayed on a channel.

The display of channels and measurements is controlled using the Display group keys to the left of the screen (see page 3-51).

Display features

Fig. 3-3 illustrates the information that is present on the screen when a single channel is displayed. If only one channel is being displayed, it occupies the whole of the screen to the left of the soft keys (the measurement area). If two channels are displayed, Channel 1 will be displayed in the top half of the measurement area, and Channel 2 will be similarly displayed in the lower half. A spectrum analyzer channel is shown here; a scalar/fault location channel is similar, except that the Rx Information area is not present, and the graticule area is correspondingly larger.

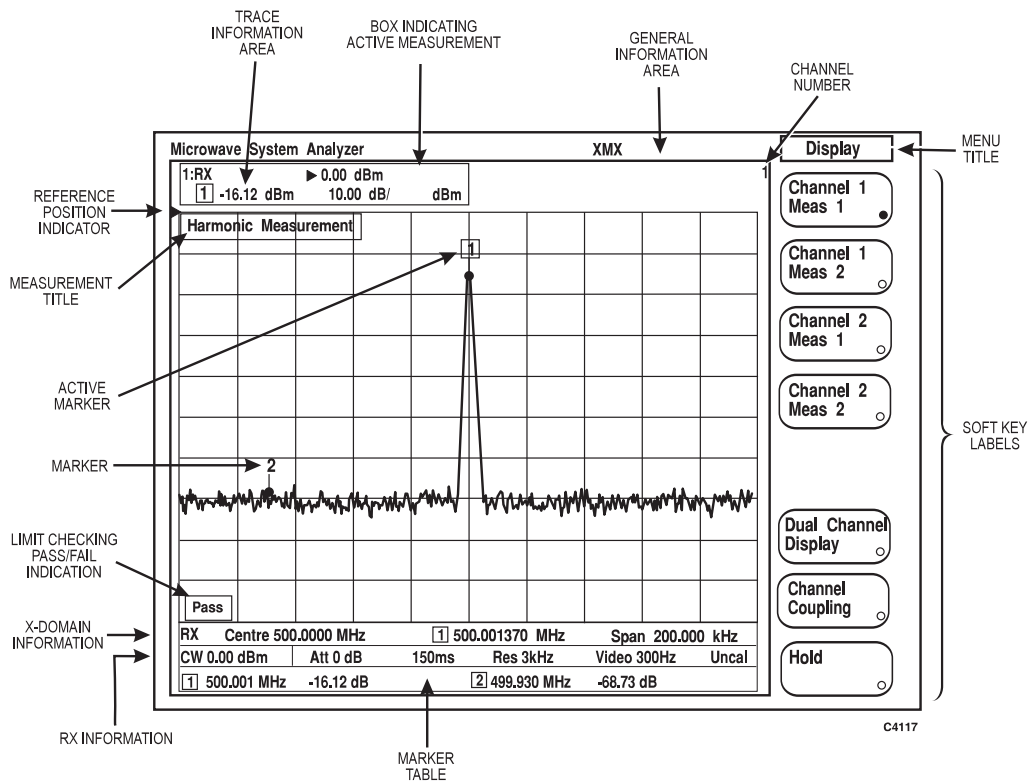

Fig. 3-3 6800A display features

Measurement Title is a descriptive alpha-numeric title which is entered by using the Titles menu, accessed via the [UTILITY] key. If two traces are displayed, the title for measurement 1 appears on the left, and measurement 2 on the right.

Menu Title is the title of the currently displayed menu. If the instrument is set for GPIB (remote) operation, the title is removed and is replaced with the appropriate indicator (see 'General Information Area').

Soft Key Labels are menu labels displayed on the screen that re-define the functions of the soft keys immediately to the right of the screen. The title of the menu is displayed at the top of the menu area to indicate where the user is within the menu structure. See 'Front panel keys and soft key menus' for a description of menu operation.

Pass/Fail Indicator displays the pass or fail status of a measurement compared to specified limits, as set up using the Lim Checking menu. Each pass/fail window will only be displayed if limit checking is turned on for that trace.

Channel Number indicates which channel is being displayed in the area.

Reference Position Indicator points to the position on the vertical scale which remains fixed during scaling. The indicator for trace 1 is shown to the left of the graticule, in the same colour as trace 1; the indicator for trace 2 is shown on the right. The reference values corresponding to the indicator positions are displayed in the relevant Trace Information Areas (see below). The position and value of the reference position indicator is set using the [SCALE / FORMAT] key.

Markers. Using the [MARKER] key, markers can be placed on a trace to identify specific points of importance on the domain (horizontal) axis of the display and to perform various measurement functions. A maximum of eight domain values can be identified at any one time, and up to eight markers can be set per trace. Markers are denoted by small numbers on the trace, in a colour corresponding to that of the measurement trace. Any of the markers can be enabled to become the active marker (indicated by enclosing the marker number in a box). In addition, a delta marker (represented by Δ) can be set.

Marker Table. The marker table shows the domain values and responses for all markers currently displayed (with the exception of the delta marker). If there are two measurements in a channel, two response values are displayed for each marker, in the colours of the corresponding measurement traces. The responses are absolute values regardless of whether the delta marker is displayed. The height of the marker table depends on how many markers are enabled. The marker table can be turned on or off; if it is turned off, more space is then available for the graticule area.

Trace information area

Scalar / fault location measurements

The trace information area comprises two lines of text indicating what the corresponding trace is displaying. If a trace is turned off, its information will not be present. The trace information area for the currently active measurements is surrounded by a box outline. A typical example of a trace information area for a scalar measurement is shown below:

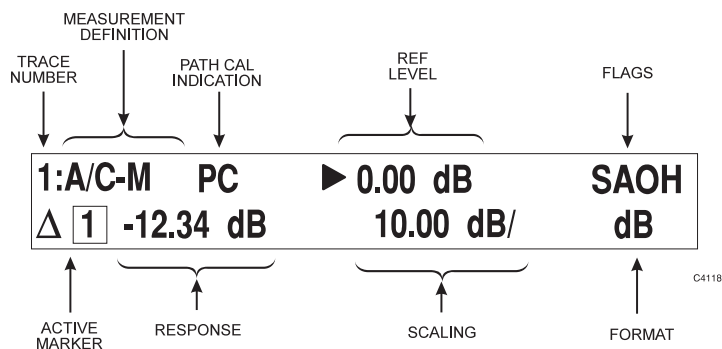

Fig. 3-4 Trace information area (scalar / fault location)

Trace Number is the number of the trace (1 or 2) that the information refers to.

Measurement Definition indicates the type of measurement that is being displayed, as follows:

A, B or C	Single input measurement
A/C or B/C	Ratioed measurement
RX	Tuned input measurement using the spectrum analyzer receiver
RX/C	Ratioed tuned input measurement
GD	Group delay measurement
-M	If the input designation is followed by -M , this indicates that the measurement is relative to a trace stored in memory
MEM	A trace stored in memory is being displayed

Path Cal indicates that the measurement is relative to a path calibration store. If the **PC** flag is followed by "?", this means that the calibration is not valid. This can occur if certain measurement parameters are changed subsequent to calibration. (See [CAL] key description.)

Ref Level is the value corresponding to the position of the associated reference position indicator on the vertical scale. It is preceded by the reference indicator symbol as displayed at the side of the graticule. The Reference Level setting function is accessed via the [SCALE / FORMAT] key.

Flags provide the following information:

S	indicates smoothing is being applied to the measurement data.
A	indicates averaging is being applied, and will be in lower case if the average number has not yet reached the target value set by the user.
O	indicates that an offset is being applied to at least one input taking part in the measurement.
H	indicates that the measurement is held (i.e. it is not being updated).

Active Marker indicates the active marker type:

1	represents an active marker.
Δ 1	represents active marker in delta mode.

The number within the box denotes the marker which has been designated the active marker.

Response is the value of the measured response at the active marker position, in units appropriate to the current measurement. In the delta marker mode, it is the measured response relative to the response at the delta marker position. The response value may be followed by:

/D	indicates that the response is the slope of the trace at the active marker position, in <i>dB per decade</i> .
/O	indicates that the response is the slope of the trace at the active marker position, in <i>dB per octave</i> .
(1Hz)	indicates that the response is the noise amplitude corrected and normalized to a 1 Hz noise power bandwidth.

Scaling shows the vertical scaling factor that has been selected, via the [SCALE / FORMAT] key, in units appropriate to the current measurement.

Format indicates the units of the measurement, e.g. dB, VSWR or Watts, as set up using the menu accessed via the [SCALE / FORMAT] key

Spectrum analyzer measurement

The trace information area for a spectrum analyzer measurement is similar to that for a scalar measurement. A typical example is shown below:

LOCAL OPERATION

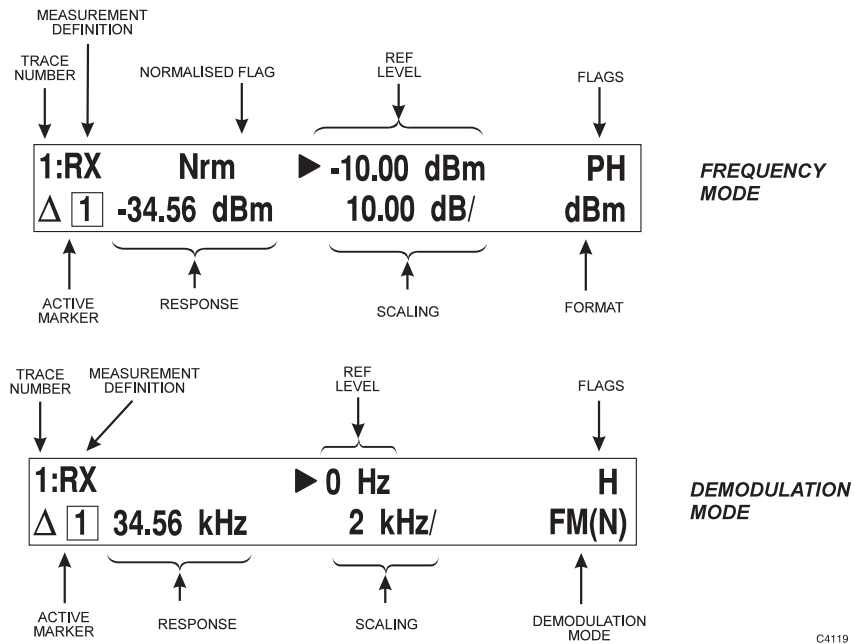

Fig. 3-5 Trace information area (spectrum analyzer)

Trace Number is the number of the trace (1 or 2) that the information refers to.

Measurement Definition shows either **RX** for a live measurement, or **MEM** indicating that the displayed measurement has been recalled from memory.

Normalised flag indicates that the normalise function has been applied to the measurement (compensates for frequency response errors due to test fixtures and cables). **Nrm** is displayed when the measurement is normalised.

Demodulation Mode indicates the type of demodulation that is being used. Currently, only narrowband FM signals can be demodulated, and is indicated by **FM(N)**.

Ref Level is the value corresponding to the position of the associated reference position indicator on the vertical scale. It is preceded by the reference indicator symbol as displayed at the side of the graticule. The Reference Level setting function is accessed via the [SCALE / FORMAT] key.

Flags provide the following information:

- P** indicates that peak hold is enabled.
- H** indicates that the measurement is held (i.e. it is not being updated).

Active Marker indicates the active marker type:

- 1 represents an active marker.
- Δ 1 represents active marker in delta mode.

The number within the box denotes the marker which has been designated the active marker.

Response is the value of the measured response at the active marker position, in units appropriate to the current measurement. In the delta marker mode, it is the measured response relative to the response at the delta marker position.

Scaling shows the vertical scaling factor that has been selected, via the [SCALE / FORMAT] key, in units appropriate to the current measurement.

Format indicates the units of the measurement, e.g. dBm, Volts, % or kHz/MHz, as set up using the menu accessed via the [SCALE / FORMAT] key

X-domain information

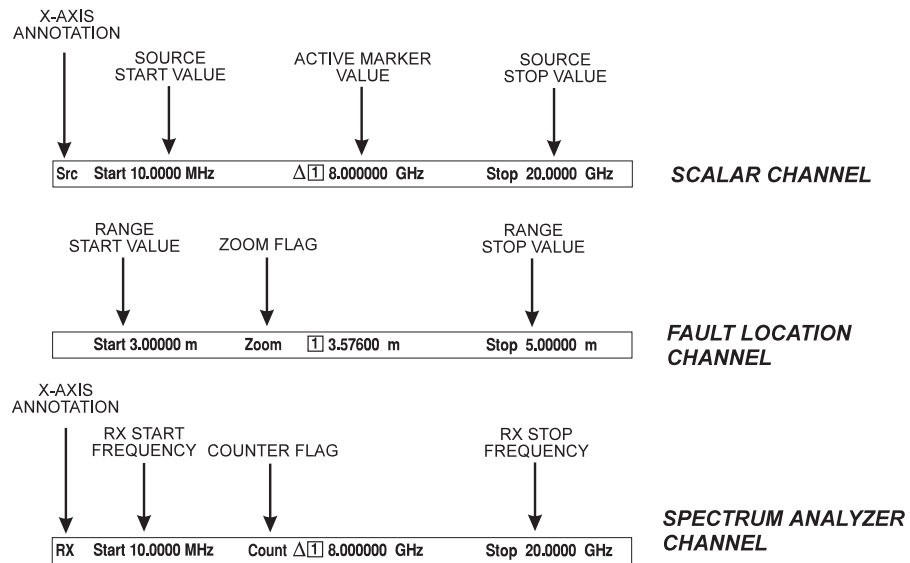

C4120

Fig. 3-6 X-domain information

Scalar analyzer measurement

Source Start Value is the start value of the sweep in units appropriate to the domain of that measurement, e.g. start frequency for a frequency sweep or start power for a power sweep. This value corresponds to the left hand edge of the display graticule. When the source is in centre/span frequency sweep mode, the centre frequency is shown in this location, and corresponds to the centre frequency graticule line.

Source Stop Value is the stop value of the sweep, and corresponds to the right hand edge of the display graticule. When the source is in centre/span frequency sweep mode, the frequency span is shown in this location.

X-axis annotation indicates the source of the x-axis information that is displayed below the graticule, as follows:

- Src** The source range (frequency or power) is shown on the x-axis.
- User** The user set range (frequency or power) is shown on the x-axis. The range is set using the X-axis Annot menu.
- OSrc** Indicates that the displayed frequency range is the source frequency range with offset/scaling applied. Also used to indicate an offset between source and displayed power when making power sweep measurements. The scaling/offset function is accessed from the Advanced Set-up menu

Fault location measurement

Range Start Value is the start value of the transmission line distance range. This will be 0 m in the normal display mode, or the start distance when a sub-range is being displayed.

Range Stop Value is the stop value of the transmission line range, and will be the entered range in the normal display mode, or the stop distance when a sub-range is being displayed

Zoom flag. This is displayed to indicate that a selected part of the distance range is being shown in magnified form.

Spectrum analyzer measurement

Rx Start Frequency is the start frequency of the spectrum analyzer receiver. When the receiver is in centre/span mode, the centre frequency is shown in this location, and corresponds to the centre frequency graticule line.

Rx Stop Frequency is the stop frequency of the spectrum analyzer receiver. When the receiver is in centre/span mode, the frequency span is shown in this location.

X-axis annotation indicates the source of the x-axis information that is displayed below the graticule, as follows:

- RX** The spectrum analyzer receiver frequency range is shown on the x-axis.
- User** The user set frequency range is shown on the x-axis.
- Src** The tracking generator frequency range is shown on the x-axis.

Count flag. This is displayed to indicate that the active marker readout is the measurement obtained from the frequency counter.

Spectrum analyzer receiver parameters

For a spectrum analyzer channel, the receiver parameters are displayed below the x-domain information.

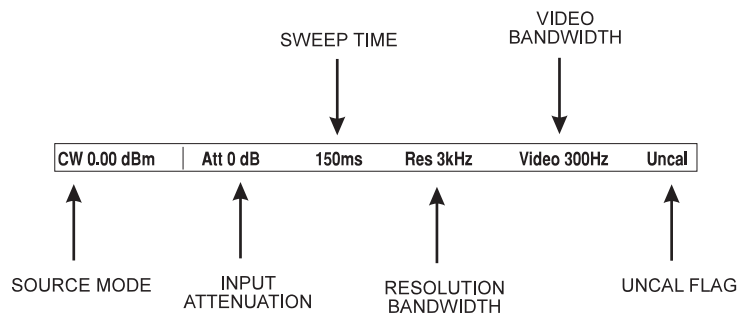

C4136

Fig. 3-7 Spectrum analyzer receiver information

Source Mode indicates the operating mode of the source during spectrum analyzer measurements, as follows:

CW indicates that the source is providing a continuous wave signal, at the specified power level (power and frequency are user-definable).

TG indicates that the source is being used as a tracking generator at the specified power level.

OTG indicates that the source is being used as a tracking generator, but its frequency is offset/scaled from the spectrum analyzer receiver frequency range.

OTG? indicates that the required tracking generator frequency range has been clipped so that it is within the range of the source. This would occur if the offset that is applied to the RX frequency is too large.

Input Attenuation is the setting of the internal RF step attenuator.

Sweep Time is the sweep time / div of the source.

Resolution Bandwidth is the bandwidth of the receiver's IF filter.

Video Bandwidth is the high frequency cutoff point of the receiver's low pass filter.

Uncal indicates that the normal coupling between parameters has been overridden, so that the instrument may not be displaying a calibrated measurement.

General information area

This area is located at the top of the screen, and provides the user with general information concerning the measurement in progress. It is displayed in the format shown in Fig. 3-8.

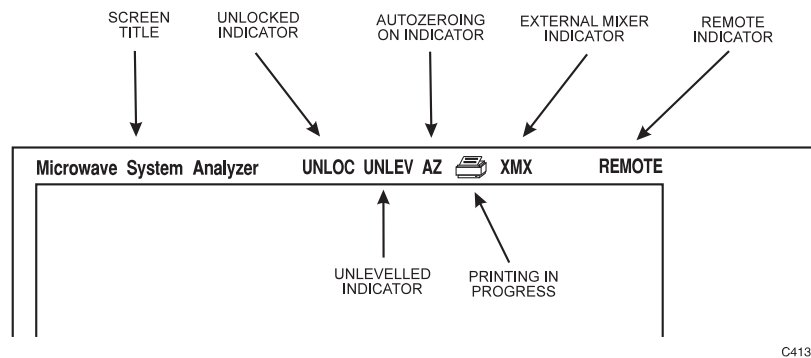

Fig. 3-8 General information area

Screen Title is the title of the screen which is entered by using the Titles menu, accessed via the [UTILITY] key.

Unlocked Indicator (UNLOC) and External Standard State Indicator (XSTD?).

UNLOC indicates that the source has failed to lock to the required frequency. **XSTD?** is displayed in this position if the instrument is set up to use an external standard, but there is either no standard detected or it is the wrong frequency.

Unlevelled Indicator (UNLEV) indicates that the source power is unlevelled.

Detector Autozeroing On Indicator (AZ) indicates that automatic zeroing of detectors has been enabled.

 indicates that printing is in progress.

MXM indicates that an external mixer is being used for spectrum analyzer measurements.

Remote Indicator (REMOTE) indicates that the instrument is in the remote state (RS-232 or GPIB). **REMLOC** is displayed if this is also local lockout mode, i.e. the front panel controls are locked out.

Error messages

During operation of the 6800A, one of several types of error message may be displayed on the screen. The message gives a description of the problem that has occurred and, where appropriate, the action that the operator can take to solve the problem. Appendix B lists all the possible error messages that the operator can receive.

Using markers

Markers are used to obtain numerical readout of trace data. They can also be used to change certain parameters, search the trace for specific values, or perform several types of measurement functions. Descriptions of the marker menus are given later in the manual, but the following describes the essential features.

The 6800A can display up to eight markers per trace, with each marker identified by a number. Any one of these can be designated the active marker, which is distinguished from the other markers by a box around the number. The active marker can be moved along the x-axis using the step keys, rotary control, or by keypad entry. The step keys and keyboard entry are only available with the [*Position Active Mkr*] function of the Markers menu, and the [*Position Delta Mkr*] function of the Delta Marker menu. The rotary control can be used to move the active marker at any time whilst it is displayed, provided that no other form of numeric entry is active. The domain value (x-axis position) of the active marker is displayed below the graticule, and the measured response at that position is displayed in the relevant trace information area.

The *delta marker* is an additional marker, represented by Δ on the display. When it is enabled, the spot reading displayed will be the reading relative to the delta marker, i.e.

$$\begin{aligned} \text{Domain readout} &= \text{Active Marker domain position} - \text{Delta Marker domain position} \\ \text{Response readout} &= \text{Active Marker response} - \text{Delta Marker response} \end{aligned}$$

Marker on/off status and position will be identical on both measurements within a channel (i.e. the markers are coupled), but will be independent on both channels.

Marker functions

Marker functions are provided that enable various types of measurement to be performed on the displayed trace. The functions available depend on the channel type, and are listed below. A tracking facility is available for some functions, whereby the function is automatically applied at each measurement update (i.e. at the end of each sweep). These are indicated by a ‘ * ’.

Scalar channel

<i>Find Max/Min</i> *	Places the active marker at the maximum (or minimum) point on the trace.
<i>Search Left/Right</i>	Places the active marker at a point on the trace that corresponds to a specified response value, searching left or right from the current active marker position.
<i>Find Pk-Pk</i> *	Finds the peak-to-peak value of a trace.
<i>Bandwidth</i> *	Used to determine the n dB bandwidth, centred on the active marker, where n is entered by the user.
<i>dB / Octave,</i> <i>dB / Decade</i>	The active marker response indicates the slope of the trace at the marker position.
<i>-1 dB Gain Compression</i>	Used for amplifier gain compression measurements.
<i>Pk-Pk Delay</i>	Various peak-to-peak functions are provided for Group Delay measurements.

Fault location channel

<i>Find Maximum</i> *	Places the active marker at the maximum point on the trace.
<i>Next Peak Left/Right</i> *	Places the active marker at the next peak left (or right) of its current position.
<i>Identify Peaks</i>	Identifies the eight highest peaks with markers.

Spectrum analyzer channel

<i>Find Peak Signal</i> *	Places the active marker at the maximum point on the trace. The marker can also be placed at the next highest peak (either left or right) that is less than the current marker response value.
<i>Identify Peaks</i>	Identifies the eight highest peaks with markers.
<i>Search Left/Right</i>	Places the active marker at a point on the trace that corresponds to a specified response value, searching left or right from the current active marker position.

<i>Frequency Counter</i>	The frequency of any spectral line on the display (up to 200 MHz) can be measured by moving the active marker to the frequency of interest.
<i>Measure Relative to Carrier</i>	Allows spectrum analyzer measurements to be made relative to a single reading (e.g. the carrier of a modulated signal).
<i>Noise in 1 Hz Bandwidth</i>	Displays noise amplitude corrected and normalised to a 1 Hz noise power bandwidth.

A function is provided to display the active marker response for the active measurement using large digits so that it may be read more easily at a greater distance.

Limit checking

Limit lines are lines drawn on the screen to represent upper and lower limits, or device specifications with which to compare the device under test. Limits are defined in segments, where each segment is a portion of the x-domain. Each limit segment can be defined with the following parameters:

- Start and Stop domain values
- Upper and lower limits corresponding to the start domain value
- Upper and lower limits corresponding to the stop domain value

Two types of segment are available: flat line and sloping line. A flat line segment has limit values which are constant with frequency or other domain value; it is not necessary to enter limits for both ends of the line. A sloping line segment has limit values which change linearly with the domain value; intermediate values are obtained by linear interpolation.

Domain values can be specified either in absolute terms or as an offset relative to a centre value. In the latter case, the resulting limit lines are reflected symmetrically about the centre value.

If segments within a specification overlap, the limit values used will be those of the segment that represents the tightest limits.

Fig. 3-9 illustrates limit lines defined for a bandpass filter.

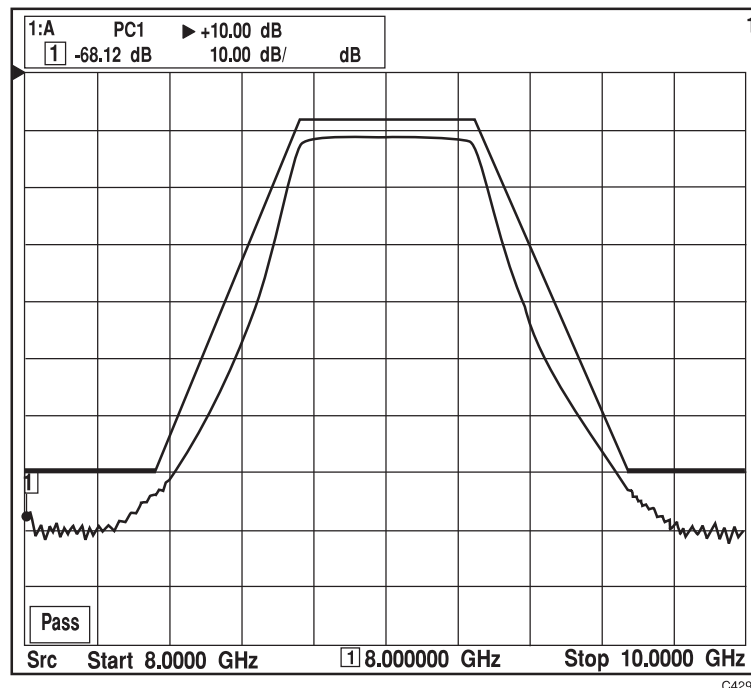

Fig. 3-9 Limit lines for bandpass filter testing

Limit checking compares the measured data with the defined limits. If all measured data points for a trace are within limits, **1:Pass** (for trace 1) or **2:Pass** (for trace 2) is displayed on the screen, as appropriate. An out-of-limits test condition is indicated by **1:FAIL (2:FAIL)**. Limits are checked only at the actual measured data points. It is possible for a device to be out of specification, without a limit test failure indication, if the point density is insufficient; therefore, it must be ensured that a high enough number of measurement points is specified when setting up the source. The pass/fail indication is also provided on hard copy.

The limit lines are superimposed on the graticule, when limit checking is enabled, and the corresponding trace is switched on. The limit lines are displayed in colours corresponding to the associated trace colours.

The definition of the limit line or lines is referred to as a *limit specification*. Different limit specifications can be assigned to each of the displayed traces, with up to 12 segments for each specification, using a combination of the segment types.

The 6800A allows many different limit specifications to be defined. These can be stored in the instrument's non-volatile memory; the maximum depends on available storage space. Additional specifications can be stored on removable storage. Any limit specification can be assigned to one or more traces.

Creating hard copy

Once a measurement has been made and a plot has been produced on the screen, it may be necessary to create a hard copy of the measurement. The [PRINT] key provides access to menus which allows output to be sent to a printer. The hard copy device can be connected to a USB port or parallel (Centronics) interface, as appropriate.

A printer can also be used to print out textual information such as limit specifications, instrument settings stores and power-on test results.

Using a printer

To create a print of the measurement, connect the printer to a USB port or the PARALLEL connector, as appropriate.

[[PRINT] Specify the printer that is to be used.
[Select Printer]

Prints can be customised by choosing which graphical attributes are to be printed (for example graticule or marker information).

[Return to Select Printer] A list is displayed showing the elements of the screen display
[Return to Print] that can be printed. These can be highlighted using the arrow
[Print Options] soft keys and turned on or off using the **[On/Off]** soft key. The
[Save Options] soft key is used to save the current print options, either to an internal store or to a file on removable storage; these can be recalled later using **[Recall Options]**.

[Return to Print] Starts the printing operation. This will be done as a background
[Print] task.

Using MIPlot

MIPlot is a software package (available from Aeroflex) that can be used to transfer measurement traces from the 6800A (and other instruments) directly into word processor documents and presentation packages running on a PC. MIPlot uses the GPIB to transfer trace data from the instrument to the PC, which then enables the data to be processed in a number of ways. For example, the graticule type, style and scaling can be re-defined, and markers and limit lines added. In addition, the graph can be annotated in various ways, and if there are several traces the can be drawn in different pen styles and colours. The resulting measurement can then be electronically pasted into the destination word processor or presentation document.

Data storage

Various types of data can be stored, either internally within the instrument or on removable storage, including:

- Measurement results
- Instrument settings
- Limit specifications
- Transmission line database records
- Print options
- Source power calibrations

When the above data is stored internally, it is saved as an MS-DOS file on the instrument's flash card (which mimics the operation of a hard disk). Data can also be saved to removable storage through the USB ports on the front panel. Other applications for removable storage are:

A new set of country specific instrument settings (e.g. language, keyboard layout, date/time format) can be installed from removable storage.

Application programs can be supplied on removable storage for installation into the instrument.

Functions that allow access to the removable storage have a **[USB Memory]** soft key in the associated menu. When this is pressed, directories and files within the current directory are listed.

Files (and also directories on removable storages) are selected by highlighting them using the **[↑]** and **[↓]** soft keys. The **[Set Store Information]** soft key allows some descriptive text to be saved with the store and a password to be specified for accessing the store. When a store is highlighted the text and password status (enabled or disabled) is displayed below the directory/file list. Described below is a typical case of saving a measurement trace to removable storage.

Described below are two typical applications of the data storage features: saving measurement traces and copying measurement traces.

Saving traces to removable storage

Once a measurement has been made and a trace produced on the screen, it can be saved as a file on removable storage. If required, a number of traces relating to a particular project can be saved under a specific directory.

[SAVE/RECALL]
[Save Trace]
[USB Memory ●]

When the removable storage function is selected, the list of measurement trace stores shown will be those found in the current directory of the removable storage inserted in the USB port. Any directories within the current directory will also be shown. The **[↑]** and **[↓]** soft keys are used to select the required store; the **[ENTER/=MKR]** key is used to change directory. Pressing the **[Save]** soft key saves the trace data as an MS-DOS file in the specified store. Either an existing store can be overwritten or a new store can be created using the **[New Store Name]** soft key.

Note that access to the removable storage is global to the instrument, and the state is preserved across visits to all menus that can access the USB ports.

New directories on a removable storage cannot be created using the 6800A; they must be created using a PC.

Entering file names will be easier and quicker if an external keyboard is used; this is connected to the keyboard interface at the rear of the instrument.

It is also possible to perform a screen dump of the entire display; this creates a bitmap file on removable storage.

[PRINT]
[Screen Dump]

The name of the file will be prompted for, and the destination can be specified (internal store or removable storage). Pressing the [OK] soft key exits the screen dump menu. The display can then be set up as required; the next time the [PRINT] key is pressed the screen dump will be performed.

Copying data between an internal store and removable storage

Measurement traces, instrument settings and other data can be copied between removable storage and the internal 6800A stores. For example:

[UTILITY]
[Store Management]
[Trace Memory]

This activates a sub-menu which enables internal directories and trace memory stores to be selected using the [\uparrow] and [\downarrow] soft keys. The [*USB Memory*] soft key is used to switch between internal and removable storage stores. A directory is entered by highlighting it then pressing [*Change Directory*]. When a store is highlighted this soft key becomes [*Delete*], which is used to remove the store.

To copy a store, it is selected as described above; if the store is on removable storage the destination will be internal store and vice versa. Pressing the [*Copy*] soft key performs the copy operation.

Other types of store can be copied/deleted in the same way.

Using the 6800A as a stand-alone source

A *source only mode* is available, in which the data acquisition system is turned off and the 6800A acts solely as a source. When in this mode, the various source settings are displayed, and all front panel keys, with the exception of the numeric keypad, units terminator keys and the [PRESET] key, will be locked out.

The source only mode is enabled by pressing the [*Enter Source Only Mode*] soft key in the Source menu. The following source settings will be displayed:

Source mode (CW, Frequency Sweep, etc.)	Levelling mode
Start & Stop values	Frequency standard mode
Number of points (if applicable)	Voltage output mode
Sweep time (if applicable)	Constant voltage value (if applicable)
Output power (CW & swept frequency modes)	Loop bandwidth mode
Output frequency (power sweep mode)	

Normal operation is restored by pressing the [*Exit Source Only Mode*] soft key on the Source menu or using the [PRESET] key.

Using an external keyboard

As an alternative to using the front panel to control the 6800A functions, the instrument can be operated from an external IBM PC keyboard connected to the rear panel KEYBOARD connector. The keys are mapped to the 6800A keys as follows:

6800A key	Keyboard	6800A key	Keyboard
Soft keys 1 to 8	F1 to F8	[PRESET]	<Alt> PR
[SPECTRUM]	<Alt> SP	[SOURCE ON/OFF]	<Alt> RF
[SCALAR]	<Alt> SC	[G n]	<Ctrl> G
[FAULT LOCATION]	<Alt> FL	[M μ]	<Ctrl> M
[RUN APPLICATION]	<Alt> RA	[k m]	<Ctrl> K
[SELECT MEAS]	<Alt> SE	[ENTER / =MKR]	<ENTER>
[SWITCH CHANNEL]	<Alt> SW	[BACK SPACE]	<BACKSPACE>
[DISPLAY]	<Alt> DI	[ENTRY OFF]	<ESC>
[SCALE / FORMAT]	<Alt> SF	Increment (\uparrow)	Up arrow key
[MARKER]	<Alt> MR	Decrement (\downarrow)	Down arrow key
[SOURCE]	<Alt> SO	[0] to [9]	0 to 9
[CAL]	<Alt> CA	[-]	-
[PRINT]	<Alt> PT	[.]	.
[SAVE / RECALL]	<Alt> SR	Rotary control	Left / right arrow keys
[UTILITY]	<Alt> UT		

International settings

The 6800A allows various instrument settings to be specified according to the country in which the instrument is to be used. These country specific settings are:

<i>Language</i>	<i>External keyboard layout</i>
<i>Date format</i>	<i>Time format</i>
<i>Decimal point</i>	<i>Spreadsheet separator</i>

The settings can be changed using the International menu, accessed via the [UTILITY] key:

[UTILITY] [International]

Displays the current settings and provides a menu for changing them. The [\uparrow] and [\downarrow] soft keys are used to select a parameter for changing. A list of the available values for the parameter appears below the parameters section. The [*Change*] soft key moves the highlight into the selection list so that a new value for the parameter can be selected, by pressing [*Select*]. The [*Go to Param Selection*] soft key moves the highlight back into the parameters section..

Note that the above parameters can be quickly set to default combinations by setting the **Country** parameter to the desired country.

Settings for additional countries may be available on removable storage, and can be installed by pressing

[UTILITY] [International] [Install New Locale]

The [\uparrow] and [\downarrow] soft keys are used to select the required country, if there are more than one. Pressing [*Add*] installs the settings into the instrument.

Using applications

Applications provide step-by-step guidance to the operator for a particular type of measurement, via prompts and diagrams. It is not necessary for the user to be familiar with the theory of the measurement, nor with the instrument's operation and menu structure.

The 6800A has the capability to install applications from removable storage into internal non-volatile memory, so that there is no need to carry the applications with the instrument.

[UTILITY]
[Applications]
[Install Application]

A list of the applications on the removable storage is displayed. The [**↑**] and [**↓**] soft keys are used to select the required application; pressing [**Install**] copies the selected application into the instrument's memory.

Once installed, the application is run using the **[RUN APPS]** key:

[RUN APPS]

The available applications stored in the instrument's memory are listed. The [**↑**] and [**↓**] soft keys are used to select the application to be run, pressing the [**Run**] soft key executes the selected application.

An installed application can be designated as Auto Run, which means that it will be executed automatically when the instrument powers up. This can be done by pressing

[UTILITY]
[Applications]
[Mark as Auto Run]

Pressing [**Select**] designates the selected application as the one to be run on power up. To restore the application to non-Auto Run, press [**Clear Auto Run**].

The Auto Run feature can be toggled on and off using **[UTILITY]** **[Applications]** **[Auto Run]**. When the instrument powers up and auto run was previously enabled, the application that has been designated as auto run will be automatically executed.

Password protection

Some of the functions accessed through the menus are password protected. A password protected function will prompt the user to enter a numeric authorisation code before the function is activated. There are three levels of password protection:

- Primary
- User-defined, Level 1
- User-defined, Level 2

When entry of a password is required for a function, a form is displayed on the screen indicating the type of password protection. The numbers are not displayed on the screen as they are entered. The entry is terminated with any units key.

Primary password

The Primary Password is a unique 6-digit authorisation code in the range 100000 to 999999. It is used to protect those calibration functions that affect the instrument's factory calibration, and some other functions including the one that allows the user to change the user-defined passwords.

Each instrument leaves the factory with the Primary Password held in the screen title associated with the instrument settings store called 'password'. This can be viewed using **[SAVE/RECALL]** **[Recall Settings]** and selecting the store. Once the primary password has been acquired, the settings store can be deleted using **[UTILITY]** **[Store Management]** **[Settings]** selecting the store then pressing [**Delete**].

User-defined passwords

Two levels of user-defined password are provided:

The User Level 1 password is a 4-digit code in the range 1000 to 9999, and protects those calibration functions which cannot affect the instrument's factory calibration. The factory set default password is 9999.

The User Level 2 password is a 6-digit code in the range 100000 to 999999. The factory set default password is 999999.

Unauthorised use protection

A function is provided to lock the user interface against unauthorised use. When enabled, normal measurement information is not displayed, and the unlocking password is requested. This password consists of 9 digits, and is set and verified by the user each time the function is used. The function is not disabled by a power-off / power-on cycle.

Store overwrite protection

When a store is saved via the user interface, the operator has the option of protecting it against overwriting by means of a unique 6 digit password. If the user decides to protect, the instrument prompts for the password, and verification, before storing. When overwriting a protected store, the instrument accepts either the unique password, or the primary password. A primary password protected function is provided, to erase all measurement and settings stores.

Entering a new password

Some instrument functions need to be enabled by entering a Level 1 or Level 2 password. A new password can be specified using the following sequence:

[UTILITY] [Security] [Set Passwords]

A primary 6-digit password must be entered in order to continue any further. Each instrument leaves the factory with the primary password held in the screen title associated with the instrument settings store called 'password'. This can be viewed using

[SAVE/RECALL][Recall Settings]

and selecting the appropriate settings store.

(If this store is overwritten at any time before the primary password has been noted, contact your nearest Aeroflex Service Centre.)

A sub-menu will then appear enabling the level 1 and level 2 passwords to be set by pressing the **[Set Level 1 Password]** and **[Set Level 2 Password]** soft keys respectively and then entering a new password.

The level 1 password is a 4-digit number in the range 1000 to 9999, and the factory set default is 9999. The level 2 password is a 6-digit number in the range 100000 to 999999, and the factory set default is 999999.

Installing a printer

Initial setup

- 1 Connect a PC-compatible USB keyboard and mouse to the USB ports on the front panel. If you have a USB hub, use it to allow the mouse to share the same port as the keyboard.
*Note: setup is quicker with a mouse, but if you do not have one, you can use the keyboard on its own. Press **ALT+F12** to enable the [Up Arrow] / [Down Arrow] [Left Arrow] / [Right Arrow] keys to move the mouse cursor. Press **ALT+N** for Next>, **ALT+D** for Model, etc.*
- 2 If a USB printer is to be added, do not connect it to the 6800A yet unless you have a port free because you are using a USB hub (see step 1). If a parallel printer is to be added, connect it to the parallel port on the rear panel and ensure that it is switched on.
- 3 Power up the 6800A and wait until the measurement screen is displayed.
- 4 Press **ALT+F4**. This terminates the 6800 measurement display application. You should now see a clear desktop.
- 5 Click on the 'K' icon at the bottom left of the screen. From the pop-up menu, click on *System Settings*.

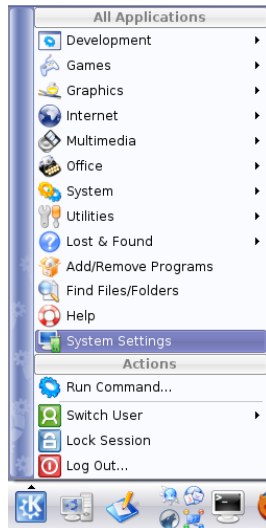

- 6 Under *Computer Administration* click on *Printers*.

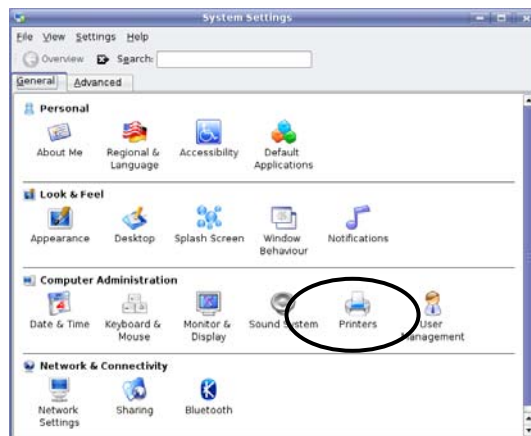

- 7 The *Printers – System Settings* window appears.
- 8 At this stage, if you are installing a USB printer, you need to connect it to a USB port on the 6800A. If you have a USB hub, use any free port; if not, disconnect the keyboard and replace it with the printer. Switch the printer on.

- 9 Select **Add\Add Printer/Class...** to run the *Add Printer Wizard*.

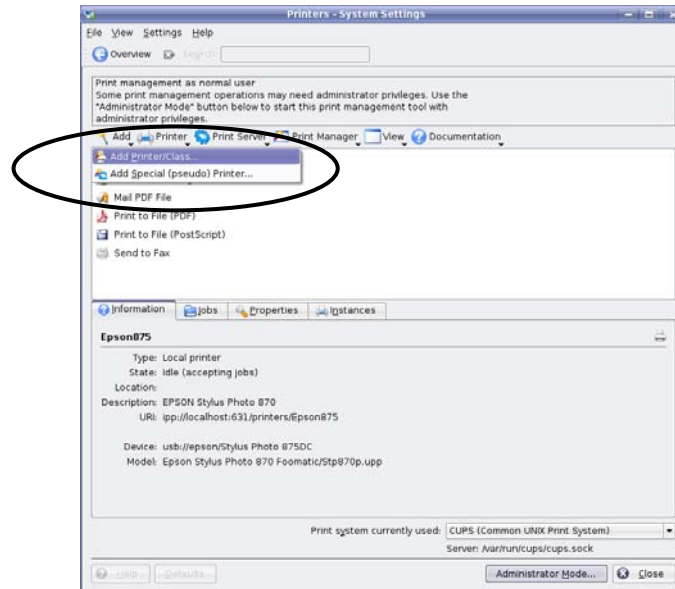

Introduction



Click **Next>** to move to the next screen.

Backend selection

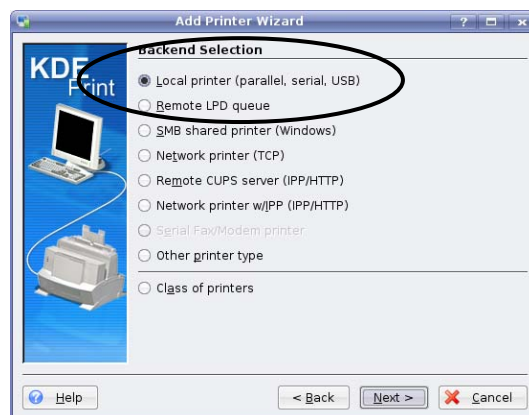

- 1 Select **Local printer (parallel, serial, USB)**.
- 2 Click **Next>** to move to the next screen.

Local port selection

USB printer

- 1 The printer should have been recognised by the system and appears under *USB* on the displayed tree diagram.
- 2 Select the required printer.
- 3 Click **Next**> to confirm the port and move to the next screen.

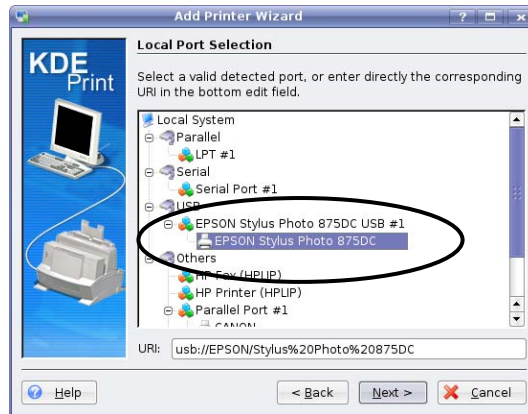

Note: the printer may appear a second time on the list under a separate branch of the tree labelled 'Others'. DO NOT select this version.

Parallel printer

- 1 The printer name does not appear on the list. Simply select 'LPT #1'.
- 2 Click **Next**> to confirm the port and move to the next screen.

Printer model selection

Note that this screen may take many seconds to load.

- 1 Select the manufacturer of the printer
- 2 Select the corresponding printer model from the list in the right-hand panel. If the precise model is not shown, the driver for a model from the same printer family may work satisfactorily. Some experimentation may be required.

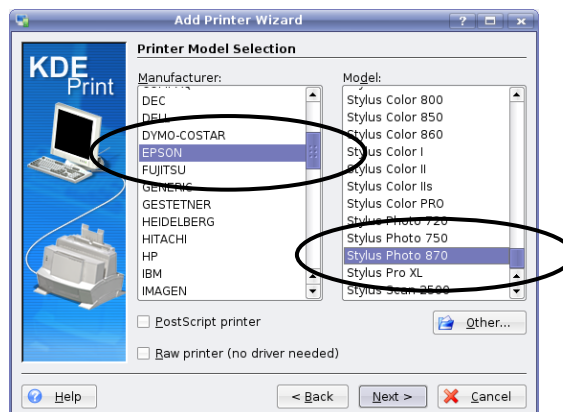

- 3 Click **Next**> to confirm the printer and move to the next screen.

Driver selection

Note that this page appears only if there is more than one driver available for the model of printer selected.

If this page does appear, it is generally advisable to accept the recommended default driver, which is highlighted automatically.

Click **Next>** to confirm the driver and move to the next screen.

Printer test

- 1 Click the **Test** button, which sends a test page to the printer. This gives a high level of confidence that the printer will work successfully with the instrument. Wait for the test page to be printed. If it is not satisfactory, click **<Back** to go back to the previous page and select a different driver. Repeat this until the test print result is satisfactory.



- 2 Click **OK** to dismiss the pop-up message.



- 3 Click **Next>** to move to the next screen.

Banner selection

Leave the default settings and click **Next>** to move to the next screen.



Printer quota settings

Leave the default settings and click **Next>** to move to the next screen.

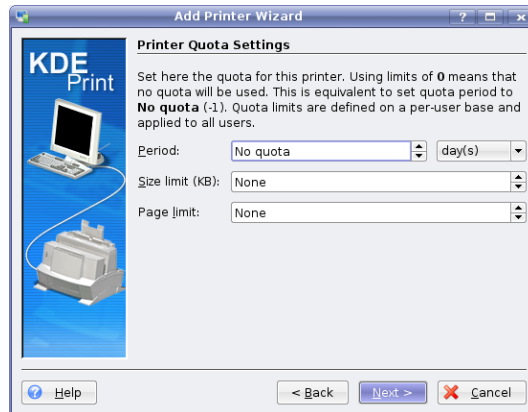

Users access settings

Leave the default settings and click **Next>** to move to the next screen.



General information

- 1 At this stage, you need to reconnect the keyboard if you disconnected it earlier. If the printer is USB, and you do not have a USB hub, disconnect the printer and connect the keyboard in its place.
- 2 Type a name for the printer (e.g. HPLaserJet). This is the name by which it is identified when selected from the instrument's front panel. Note that space characters are not allowed.
- 3 Click **Next>** to confirm the name and move to the next screen.



Confirmation

- 1 Click **Finish** to finish the wizard.

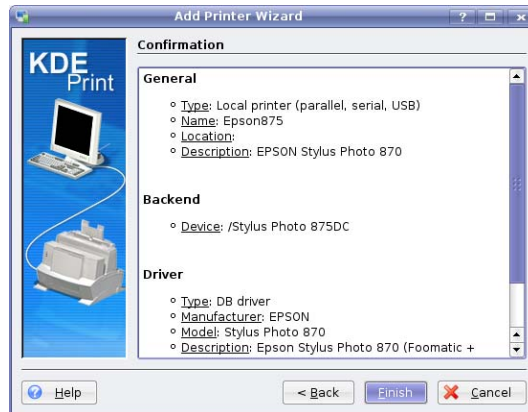

- 3 Click **Close** to exit from the System Settings application.

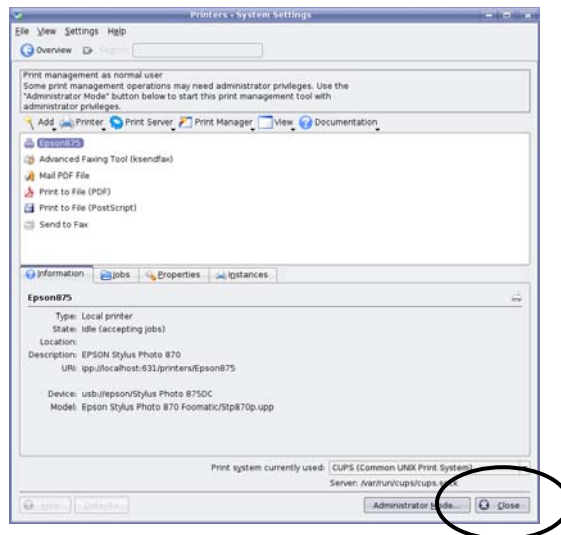

- 3 Power the 6800A off and then on again.

The printer you have just added is listed when you press **[PRINT] [Select Printer]**, and can be selected using the **[↑]**, **[↓]** and **[Select]** soft keys.

Substituting a printer with another of the same model

Some USB printers identify themselves by model via the plug-and-play system, and some by a combination of model and serial number. Printers that identify themselves by model only can be readily substituted with another of the same model, and the new printer will be recognised by the 6800A.

However, those identified by model *and* serial number cannot be substituted by another of the same model since the serial number part of the new identifier does not match that stored in the 6800A. In this case, the substitute printer must be installed as a new device, using the above procedure.

Removing a printer

- 1 Connect a PC-compatible USB mouse to a USB port on the front panel.
- 2 Power up the 6800A and wait until the measurement screen is displayed.
- 3 Press **ALT+F4**. This terminates the 6800 measurement display application. You should now see a clear desktop.
- 4 Click on the 'K' icon at the bottom left of the screen. From the pop-up menu, click on *System Settings*.

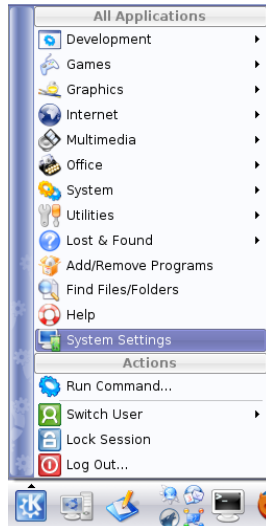

- 5 Under *Computer Administration* click on *Printers*.

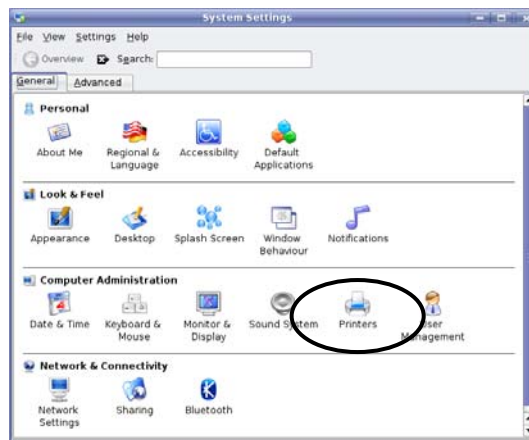

LOCAL OPERATION

- 6 The *Printers – System Settings* window appears. It shows the currently installed printer(s).

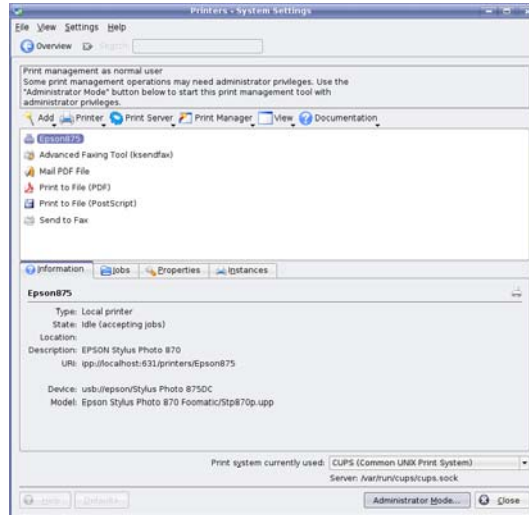

- 7 Right-click the printer you want to remove. Select Remove from the drop-down menu.

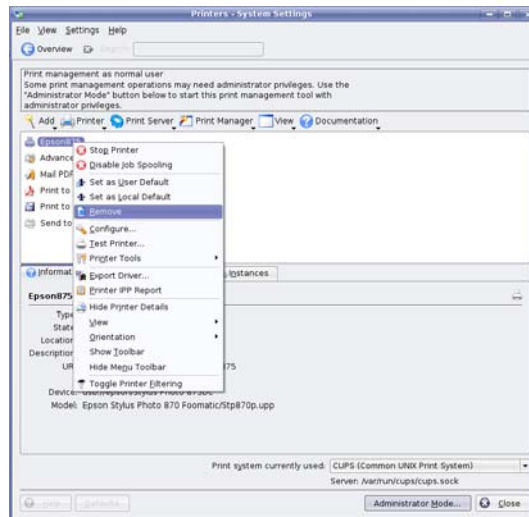

- 8 When asked, confirm that you want to remove the printer. The printer is removed.

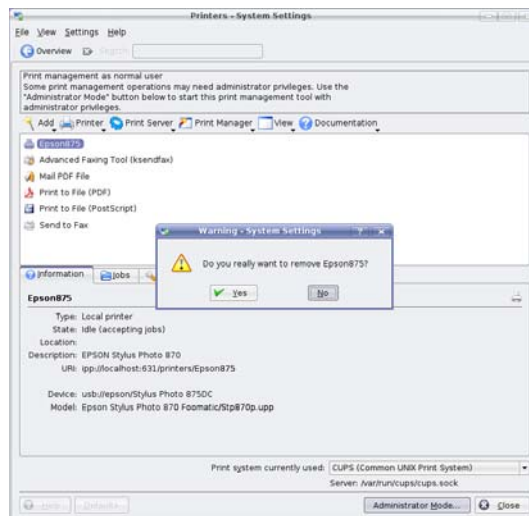

- 9 Click **C**lose to exit from the System Settings application.
- 10 Power the 6800A off and then on again to return to normal operation.

Setting up the LCD

Facilities are provided to set the backlight brightness and colour palette for the LCD. The backlight brightness can be selected from four settings (plus Off). For instruments with a monochrome LCD, the colour palette function is replaced by one that allows the contrast to be set. These functions are available from the Display menu, accessed via the [UTILITY] key:

[UTILITY]
[Service]
[Set-up]
[Display]

The [*Minimum Brightness*], [*Low Brightness*], [*High Brightness*] and [*Maximum Brightness*] soft keys are used to set the brightness level of the backlight. For a monochrome display it can also be turned off.

Pressing the [*Colour Palettes*] soft key (colour displays) leads to a sub-menu from which a colour palette can be selected

Pressing the [*Contrast*] soft key (monochrome displays) allows the contrast to be set between 0 and 100%.

Setting the real time clock

A real time clock is provided which can be used to date/time stamp hard copy output or files sent to removable storage. If necessary, the real time clock can be set as follows:

[UTILITY]
[Service]
[Set-up]
[Set Date & Time]

Enters the Date & Time menu and the current date and time are displayed.

Pressing [*Enter Date*] allows the date to be changed. When a terminator key is pressed to enter a value the next field will be selected. Pressing [*Enter Time*] allows the time to be similarly changed. When the [*Store Date & Time*] soft key is pressed the new numbers are checked. If the checks pass then the instrument's real-time clock and calendar will be updated with the entered values.

Remote operation

The 6800A can be controlled remotely via the GPIB or RS-232 (serial) interfaces. The GPIB interface provides instrument control with full talk and listen capability. Full details for controlling the instrument remotely are contained in the Remote Operation Manual

Making measurements

This section provides general information on the fundamental measurement types available with the 6800A. Refer to page 3-12 for a summary of the functions available through the front panel hard keys. The Getting Started manual gives detailed examples of the many types of measurement that can be made with the instrument. Following on from this section are detailed descriptions of all the 6800A menus.

Precautions

Microwave connectors

Care should be taken when using microwave connectors, both on the 6800A and any accessories that are used, such as cables, adapters, attenuators, etc. Complying with the following precautionary notes will ensure longer component life time and less equipment downtime due to connector or component failure. These measures will also help to ensure that the components will operate within specification and give repeatable results.

- The precision connectors fitted to the 6800A, and its accessories may be damaged by mating with a non-precision type. Damage to these and other connectors may occur if the connector interface parameters are not within specification. This should be checked with the appropriate gauging tool. It is strongly recommended that every connector be gauged prior to its first use and regularly thereafter, e.g. every 20 connections.
- The precise geometry of the connectors can be easily degraded by dirt and other contamination adhering to connector interfaces. Alcohol is the recommended cleaning agent, and a clean, damp cotton swab is the recommended applicator. When not in use, keep the connectors covered with the protective caps provided.
- Always use the correct mating techniques. In particular, the two connectors to be mated should be pressed together such that the pin penetrates the collet prior to the nut being tightened. Never rotate one connector body relative to the other because this wears out the mating interfaces, thus reducing connector lifetime.
- Avoid over-torquing connectors during mating, because it may damage the connector centre pin or may cause the connector body to turn in its housing.
- Avoid mechanical shock by dropping or otherwise roughly handling microwave components.

Excessive detector input power

The 6230A/L Series EEPROM scalar detectors that are used with the 6800A utilise zero-biased Schottky diodes. These are of a physically small geometry and consequently can be damaged under high power conditions. **It is strongly recommended that care is taken to avoid exceeding an input power of +20 dBm for 'A' versions and +26 dBm for 'L' versions during normal operation.**

Switching on

Connect the 6800A to the AC supply using the AC supply lead provided with the instrument.

If the yellow SOFT START LED that is adjacent to the front panel SUPPLY switch is illuminated, this indicates that AC power is being applied to the instrument; if not, operate the switch above the AC supply connector. Pressing the SUPPLY switch activates the instrument and the green POWER LED will illuminate.

A self-test routine is first of all carried out; if the self-test fails, the test results are logged and a message is displayed. To access the test results, press **[UTILITY] [Service] [Status] [Display Test Results]** which will indicate the reason for the failure.

Once the self tests have been completed, the instrument will be automatically set up to the state it was in when it was last powered down. However, the **[PRESET]** key can be used to force the instrument into its default state, or to preset the instrument according to the contents of a user-defined settings store (the **[Save Settings as User Default]** soft key in the Save/Recall menu is used to save instrument settings to a user default settings store).

Scalar measurements

Scalar measurements that can be performed with the 6800A include insertion loss/gain and return loss of components (e.g. filters and attenuators) and transmission lines.

When making **insertion loss/gain** measurements, a stimulus is applied to the device or sub-system under test and the response is measured with a broadband detector and displayed by a scalar amplitude analyzer. The stimulus is in the form of a frequency sweep over the required bandwidth at a fixed power level. The 6800A uses a synthesized signal source that can be used as both a CW source or synthesized sweep generator. The 6800A's scalar analyzer has three inputs, enabling two measurement to be displayed simultaneously, together with the use of a reference signal to reduce errors.

The measurement of **return loss** (or VSWR) is a basic measurement used for the characterisation of a system in the frequency domain. The measurement involves applying an RF signal over the operating bandwidth of the component or system and measuring the amount of power reflected by impedance discontinuities within the system. The return loss is the ratio of reflected signal to input signal, expressed in dB. A directional device is used to separate the input and reflected signals. For coaxial systems this usually takes the form of a bridge network (either a return loss bridge or an autotester); a directional coupler is used in waveguide systems.

Where there is a need to derive both transmission (insertion loss) and reflection (return loss/VSWR) data for a two-port component, both these measurements can be performed simultaneously.

It is also possible to make **single-ended insertion loss** measurements on a long transmission line when simultaneous access to both ends of the line is impractical. This is done by measuring return loss, and the instrument performs the necessary calculation to derive the insertion loss. Since the measurement is essentially a return loss calibration, this feature is accessed via the Cal menu.

Some components, such as amplifiers and limiters, have a power response characteristic in addition to their frequency response. To test these devices, the input power level is swept rather than the frequency, and the horizontal axis is annotated for input power. A typical example is gain compression measurement of power amplifiers.

Source control

Source modes

The following source modes are available:

<i>Start / Stop Frequency Sweep</i>	Linear frequency sweep between user-defined start and stop values (this is the default).
<i>Centre / Span Frequency Sweep</i>	Linear frequency sweep defined by its centre frequency and span.
<i>CW</i>	Continuous wave output at user-defined frequency and power. The CW signal can be frequency modulated (external FM with no options fitted; internal and external FM when Option 23 fitted) and pulse modulated (external pulse with Option 25 fitted; internal and external pulse with Options 23 and 25 fitted).
<i>Power Sweep</i>	Linear power sweep between user-defined start and stop values.

The number of measurement points and the sweep time can be set.

Levelling

Levelling is used to control the power level of the instrument's RF source, via a fast, closed-loop feedback system. The control (feedback) signal used to level the output can be derived from either the internal levelling detector of the 6800A, or from an external detector or power meter, connected to the rear panel EXT LEVEL INPUT

Internal levelling provides a constant signal at the SIGNAL SOURCE OUTPUT connector regardless of reflections by adjusting the level of the source, thus improving the source match. A further improvement in source match can be gained by using the external levelling mode, so that levelling is done, at a point in the system, closer to the test port. The emergent signal, at the levelled point in the system, is constant, regardless of the signal travelling back towards the source; in this way the source appears matched.

Frequency standard

Under normal circumstances the internal crystal oscillator of the 6800A would be used as a frequency reference for the synthesized source. If necessary, however, an external frequency standard of higher accuracy and stability can be connected to the **FREQ STANDARD** rear panel connector. Either a 1 MHz or 10 MHz external frequency can be used, as specified in the **Freq Standard** menu.

Voltage output

The integral voltage source (available at the rear panel **AUX D-type** connector) can be used to provide a fixed voltage to bias devices such as PIN attenuators, or to provide a ramp voltage proportional to swept frequency or power. It can also be used to provide a voltage proportional to the active marker readout of the active measurement.

Frequency modulation of the source

The source can be frequency modulated (in CW mode) using an external modulating signal applied to the rear panel **MOD IN/OUT** connector. An internally-generated modulating signal can be used if the **Internal FM** option is fitted. If the **Group Delay** option is fitted (6840A Series only), the modulation generator provided for the **Group Delay** function can be used independently as an internal modulating source. The FM deviation can be set for both internal and external modulation.

Pulse modulation of the source

The source can be pulse modulated (in CW or swept mode) by an external pulse applied to the rear panel **MOD IN/OUT** connector if the **Internal Pulse Modulator** option (6820A Series only) is fitted. Internally-generated pulses can be used if both the **Internal FM** and **Internal Pulse Modulator** options are fitted. Pulse width and other characteristics can be set for internal modulation. If the **Internal FM** option only is fitted, pulses are fed to the the rear panel **MOD IN/OUT** connector to drive an external pulse modulator.

Measurement definition

A scalar analyzer measurement can be defined as one of the following:

- Absolute power measurement from scalar input A, B or C.
- Ratio measurement of scalar inputs: A/C or B/C
- Absolute power measurement from the spectrum analyzer receiver.
- Ratio measurement of the spectrum analyzer input to input C
- The contents of a measurement store.

Scalar inputs

Scalar measurements are performed using the 6230A/L Series EEPROM detectors. The EEPROM contains power linearity and flatness (frequency response) correction data for the detector. When the detector is connected to an input, the correction data is read by the instrument and applied to the measurement (correction can be turned on and off for each input). The range of frequencies used to look up flatness correction is defined by the channel's displayed start and stop values.

An offset in dB can be defined and applied to each input, for example when compensating for attenuators or amplifiers between the detector and the device under test.

All detectors can be zeroed, either manually or automatically .

Voltage adapter cables are available which enable voltage measurements to be made over a limited range.

Using the spectrum analyzer input

The spectrum analyzer receiver can be used in place of a scalar detector in order to give frequency selective scalar analyzer measurements (*tuned input* mode). Because of the reduced bandwidth over which the measurement is made, there is less broadband thermal noise in the measurement (which is proportional to bandwidth). The reduced noise floor allows increased dynamic range measurements of insertion loss / frequency response to be made on filters, duplexers etc. The tuned input method can also be used to improve transmission line measurements in microwave systems by rejecting interfering signals from other transmitters.

The spectrum analyzer receiver parameters are determined automatically based on the displayed frequency range, although the Operating Signal Level can be set. An offset in dB can be applied to the receiver input, as for scalar inputs.

Conversion measurements

When making conversion gain/loss measurements on frequency translation devices such as mixers, up-converters and down-converters, the x-axis can be set up to display the frequency range of the signal measured at the output of the device, rather than the source frequency range. This is achieved by using a scale/offset function, which enables the frequency displayed on the x-axis to be scaled and/or offset from the source frequency. For mixer measurements, a function is provided to simplify instrument setup; the offset and scaling are set by the instrument when the local oscillator frequency and either the input or output frequency range have been specified.

Power conversion devices such as amplifiers can similarly be measured, by displaying a power sweep range that is offset from the source power range.

Group delay measurements

An important property of a communications link or signal processing device is its ability to convey information, in the form of a modulated signal, without distortion. This requires a flat amplitude response and linear phase response over the bandwidth of interest. A linear phase response means that components of differing frequencies will be delayed by the same amount so that no distortion will occur. The deviation from linear phase can be measured and expressed as *group delay*. Group delay is the transit time through the device under test (DUT) as a function of frequency. Mathematically it is the derivative of the phase response:

$$T_g = \frac{d\phi}{d\omega}$$

where ϕ is phase (radians) and ω is angular frequency (radians/second).

A 6840A series instrument (with the Group Delay option fitted) measures group delay using the *envelope delay* technique. A modulated carrier is passed to the device under test (DUT) and the output is demodulated to recover the modulating signal (envelope). The phase of the recovered signal is then compared to the original modulating signal and the group delay can then be calculated. Frequency modulation (FM) is used rather than amplitude modulation since some devices (particularly those incorporating automatic gain control) may perform differently when the input is varying in amplitude.

The bandwidth of the modulated signal forms a measurement *aperture*; over this aperture, fine variations in group delay are averaged out. Reducing the aperture will reduce the smoothing effect on the group delay trace, at the expense of greater measurement noise. A wider aperture reduces noise but results in a loss of fine variations in group delay. In this system, aperture depends on the values selected for the Group Delay Range and FM Deviation parameters. This is normally set automatically by the instrument, although it can be manually set if required (refer to the Group Delay menu, page 3-66).

An important advantage of the envelope delay technique is that since the group delay is derived from the modulation envelope and not the carrier frequency, the technique can be applied to measure frequency converting devices.

The 6840A calculates the group delay from the phase difference ($\Delta\phi$) and modulating frequency (f_m) using

$$T_g = \frac{\Delta\phi_{\text{degrees}}}{360 \times f_m} \quad \text{or} \quad T_g (ns) = \frac{2.7778 \times \Delta\phi_{\text{degrees}}}{f_m (MHz)}$$

The group delay as a function of frequency can then be displayed, together with a frequency response (insertion loss) measurement if required. The marker functions can be used to make various measurements, and can be applied either to the full range of the sweep or to a specified sub-range.

Group delay measurements are incorporated into the scalar measurement channel facilities.

Calibration

Any components such as cables and adapters placed between the 6800A's RF output and the device under test (DUT) will have their own insertion loss v. frequency characteristic. The scalar detector that is used to make the measurement also has a power variation with frequency, but this can be corrected for by utilising the flatness correction data held in the detector's EEPROM. However, all the other power variations with frequency will affect the accuracy of the measurement. Their effect can be removed by performing a *path calibration*, i.e. by calibrating out the variations in the measurement path.

Insertion loss measurements. When making insertion loss (or frequency response) measurements, an RF cable is usually connected between the source output and the DUT. A simple *through calibration* is performed, whereby the DUT is replaced by a through connection (e.g. a high quality back-to-back adapter) and a measurement is made. The resulting data, representing the frequency response of the measurement system, is stored in a path calibration store. Path calibration is applied to the measurement by dividing the linear measurement trace by the stored path cal trace point by point (or subtracting the dB values).

Return loss measurements. When measuring return loss, a *short/open calibration* needs to be performed, in which the system is calibrated against a reference. The reference signal is generated by reflecting all the power at the test port, a proportion of which appears at the coupled port of the directional coupler (or the detector port of the bridge/autotester). To achieve this, open circuit or short circuit terminations are chosen as both these devices theoretically reflect 100% of the power incident upon them, and therefore have a return loss of 0 dB. This reference signal is stored within the instrument and subtracted from the measured reflected power from the DUT.

If only an open circuit or short circuit is used, however, there is an uncertainty added to the measurement due to test port impedance mismatch. This uncertainty can be minimized by calibrating the system against both open and short circuits, then calculating the average (done automatically by the 6800A).

In some cases it is only necessary to perform either a short or an open calibration. At lower frequencies (< 1 GHz) it is only necessary to leave the DUT port open for the calibration, since this will result in 100% reflection at lower frequencies. When measuring the return loss of a waveguide, only a short calibration needs to be performed, since a practical open circuit is not achievable for waveguide systems.

In addition to the above calibration features, detectors (and autotesters) can be zeroed, either manually or automatically; this compensates for any residual voltages present at the detector output.

Group delay measurements. Calibration for group delay measurements is similar to that of a conventional 'through' path calibration for insertion loss, except that delay time (rather than amplitude) is stored and the calibration data is subtracted point-by-point from the measurement rather than divided into the measurement. This normalises the measurement to remove any delays in the measurement system.

Fault location measurements

If the return loss measurement of a transmission line system fails to meet specification a fault location measurement can be used to provide a precise identification of the faulty component. As with return loss measurements, fault location measurements also involve applying an RF signal to the transmission line over the operating bandwidth. The reflected signals are recombined with the input signal to produce a ripple pattern. Encoded within the ripple pattern are amplitude and distance information for all the reflections occurring within the line. The 6800A uses signal processing techniques to compute the time domain response. Since the velocity of propagation in the transmission line will be known, the response can be represented on a distance scale.

The location of peaks on the resulting fault location display represents the position of the cause of reflections along a transmission path; the amplitude of the peaks depends on the reflection coefficient of the fault. Further information on fault location measurements can be found in Appendix C.

To simplify the measurements and reduce the test time a 6240 Series Fault Locator is used. This is a small unit that contains a patented[†] combination bridge and fault locating network for making real time fault location and return loss measurements simultaneously via a single test port. Calibration data for the Fault Locator is held in EEPROM within the unit, which can be read by the 6800A.

The fault location channel is similar to scalar except that:

If a 6240 Series Fault Locator is connected to one of the scalar inputs, the measurement definition assumes a single detector fault location measurement on that input (i.e. no reference detector). If a 6240 Series device is not detected, the system assumes that the measurement is to be made with an RF divider and a single detector connected to input B. If the instrument finds a detector connected to input C (and no Fault Locator connected to A or B, the measurement is set automatically to B/C to maintain compatibility with 6581/6583 transmission line test heads

Due to the nature of a fault location measurement, the user does not have the same degree of control over the source.

The choice of formats is restricted to dB and VSWR.

Only one live measurement can be displayed within a channel and channels cannot be coupled.

Since the frequency span of the source and the length (Range) of the transmission line are interdependent, two methods of parameter entry are provided:

Range Entry mode - the range is entered and this determines the frequency span over which the source is swept.

Frequency Entry mode - the source start and stop frequencies are entered and the range is calculated from these values.

As for scalar measurements, the tuned input can be used to improve fault location measurements on coaxial cables (it should not be used for waveguides). For fault location measurements, however, the Resolution Bandwidth and Operating Signal Level are set to 3 MHz and +6 dBm respectively.

Transmission line database

Parameters that need to be specified when making fault location measurements are Relative Velocity (coax only), Cutoff Frequency (waveguide only) and attenuation. These values can be set automatically by selecting the appropriate transmission line type from the Transmission Line Database. The database contains data for various transmission line types and search facilities are provided.

[†] The 6240 Series Fault Locators are protected by the following patents:
US 536 3049, GB 2263783

Fault location calibration

As for a scalar measurement, it is necessary to perform a path calibration to compensate for the effects of the frequency response of the measurement system. This is done by connecting a matched load to the test port of the Fault Locator and measuring the scalar response of the circuitry within the unit. The response is stored in a path calibration store and applied to the measurement.

Fault location features

- **Masking correction.** For some measurements *masking correction* can be used to give more accurate results for amplitude. A large peak in a fault location measurement (due to a discontinuity or mismatch) can cause an error in the apparent magnitude of a fault beyond it, leading to underestimates in the severity of distant faults. This effect is cumulative, but can be compensated for by applying masking correction.
- **Windowing.** This is a function which is applied to the acquired fault location data. Data windowing reduces the amplitudes of the sidelobes associated with the main peak of the display, but gives reduced distance resolution. Variation of the windowing level provides a trade-off between distance resolution and the height of the sidelobes; three levels of windowing are provided.
- **Zoom mode.** This function allows a part of the transmission line that is of particular interest to be expanded for more detailed examination, for example a connector or the interface between two sections of transmission line. Following calibration, the horizontal axis will display distance between zero and the length of the line. The zoom facility enables a sub-range of displayed distance values to be specified.

Spectrum analyzer measurements

A common requirement in RF and microwave measurements is to examine two or more signals which are close together in frequency, identify low level signals (such as modulation, harmonics and noise) in the presence of high level signals, and accurately measure the frequency and level of signals. In order to do this, it is necessary to understand the basic functioning of a spectrum analyzer and the parameters and settings of a spectrum analyzer which affect the accuracy and repeatability of measurements.

Whereas a scalar analyzer measures the response of a device or sub-system due to an applied stimulus, a spectrum analyzer is generally used to analyze the frequency content of a signal. The signal is represented by displaying the amplitude of its frequency components. The frequency resolution and the part of the spectrum to be analyzed are easily set by the user.

RF and microwave spectrum analyzers operate on the following principle. A ramp generator sweeps a local oscillator, whose output is mixed with the input signal to be measured. The output from the mixer is a fixed intermediate frequency; this passes through switchable band pass IF filters and is then detected. The horizontal axis of the display is driven by the ramp generator and the vertical axis by the detector output.

One or two live measurements can be displayed simultaneously.

Spectrum analyzer controls

The main spectrum analyzer controls are:

- **Frequency range.** This is the frequency range of the spectrum analyzer receiver, and determines the part of the spectrum that is to be analyzed.
- **Reference level.** This is the response value that corresponds to the top graticule line for dBm, dB μ V and Volts formats, and the middle line for kHz/MHz formats (when viewing FM demodulated waveforms).

- **Resolution bandwidth.** This is the bandwidth of the IF filter. Resolution is the ability of the analyzer to discriminate between signals closely separated in frequency. For example, if two tones are analyzed, the analyzer will only be able to discriminate between them if the resolution bandwidth selected is narrower than the tone separation. Filter selection becomes more critical if the tones are at different levels. Narrow resolution bandwidth also results in lower noise on the trace. The resolution bandwidth can be changed between 1 kHz and 3 MHz in a 1, 3, 10... sequence.
- **Video bandwidth.** Signals close to the noise level will be hard to see clearly. To overcome this, a low pass filter (called the video filter) is introduced after the detector. The video bandwidth is the high frequency cutoff point of the filter. The video filter reduces high frequency noise on the detected signal and enables low level signals to be identified that would otherwise be buried in the noise. The video bandwidth can be changed between 1 Hz and 100 kHz in a 1, 3, 10... sequence.
- **Sweep time.** Due to the finite bandwidth of the resolution filters, it takes time for the energy to build up in the filter as the spectrum analyzer sweeps through a signal. If the analyzer is sweeping too fast, the resolution filters will not respond correctly; this results in the signal being reduced in amplitude and appearing to the right of the correct position. The narrower the filter, the slower the sweep speed must be.
- **Input attenuation.** This is the setting of the internal RF step attenuator, which is needed to prevent high signal levels appearing at the input of the first mixer, resulting in the generation of unwanted intermodulation products.

Coupling of parameters

Under normal circumstances the operator would set the frequency range of the receiver and the reference level. RF attenuation, video bandwidth, resolution bandwidth and sweep time are set automatically by the instrument, but these settings can be uncoupled so that they can be set explicitly by the operator.

Following setting of the frequency span, the instrument maintains the fastest possible sweep time subject to the restriction that $\text{Span} / \text{Resolution Bandwidth} \geq 50$ at all times. The resolution bandwidth setting will be adjusted, if necessary, to maintain that condition.

Following setting of the reference level, the input attenuator (and also IF and video stages) are set optimally for a signal corresponding to the reference level. The attenuator is set to give optimum dynamic range by maintaining the signal level at the input to the first mixer such that internally generated intermodulation or distortion products do not appear greater than the noise level. (When the input attenuator is controlled manually, however, overloading can occur and distortion products can be produced.)

Following setting of the resolution bandwidth or video bandwidth, the optimum setting of sweep time for the current frequency span will be determined automatically.

Other useful features

- **Auto tune.** Sets up a spectrum analyzer measurement automatically: A wideband measurement is performed, and the receiver tuning and reference level settings are adjusted to place the peak with the highest amplitude at the reference level, and at the centre of the screen. The span is set to 20 MHz. The frequency step size is set equal to the centred signal frequency in order to facilitate stepping between harmonics.
- **Signal tracking.** When enabled, this function causes the spectrum analyzer centre frequency to be adjusted, at the end of each sweep, in order to place the signal identified by the active marker at the centre of the display. This will prevent the signal going outside the sweep range, and disappearing from the screen, when narrowband sweeps are being used.
- **Tracking generator.** When enabled, the 6800A source is used as a tracking generator, i.e. it produces a swept signal whose frequency precisely tracks the tuning of the spectrum analyzer receiver. The tracking generator can be used to provide the sweeping signal for measuring the frequency response of both active and passive devices. In order to allow measurements of frequency translation devices, frequency offset and scaling can be introduced between the tracking generator frequency range and the spectrum analyzer receiver.

- **Demodulation facilities.** In the demodulation mode the analyzer acts as a fixed tuned receiver and is used for recovering modulating signals or for real time monitoring of a signal. FM demodulated signals can be analyzed by displaying FM deviation (kHz/MHz) against a time axis. The signals can also be heard by using the integral loudspeaker. The major use for demodulation is to help identify the origin of a spurious transmission.
- **Counter facility.** The frequency of any spectral line on the display can be measured by moving the active marker on the active channel to the frequency of interest. The resolution of the readout can be varied.

Normalisation

This function is used in conjunction with the tracking generator output to compensate for frequency response errors incurred by the spectrum analyzer cables and test fixtures. This permits the frequency response of a filter or amplifier, for example, to be displayed with all external errors removed.

A measurement is first of all made with the test setup in place but with the device under test replaced by a through connection. When the device under test is connected and normalising is enabled, the resulting response will be that for the device only, the effects of the extraneous circuitry being nullified. This is the equivalent of a through path calibration when making scalar measurements.

General measurement procedure

The following describes briefly the steps required to make measurements with the 6800A.

- Use [**PRESET**] to put the instrument into a known state. This can be the instrument default state as defined in Appendix A, or can be derived from a default settings store defined by the user.
- Use [**DISPLAY**] to define the display configuration, i.e. single or dual channel display, with each channel displaying one or two measurements.
- Use [**SCALAR**], [**FAULT LOCATION**] or [**SPECTRUM**] to define the measurements to be made.
- Use [**SOURCE**] to define the stimulus to be applied during the measurement.
- Use [**CAL**] to calibrate out any systematic errors in the measurement path, and to zero detectors.
- Use [**SCALE/FORMAT**] to select the appropriate scale and position for each measurement trace, and to select the units for each measurement response.
- Use [**MARKER**] and other 6800A features to examine the measurement in detail and perform various types of analysis.

Additionally, the following 6800A features can be used once a measurement has been made:

- Use [**PRINT**] to create a permanent record of the measurement results, using a suitable printer, with comprehensive control over which aspects of the display are to appear on the hard copy.
- Use [**SAVE/RECALL**] to save the instrument state or measurement traces for future use, either to internal 6800A stores or to removable storage. It can also be used to specify measurements relative to memory.

The remainder of this chapter describes the 6800A menus in detail, and the Getting Started manual gives detailed examples of the many types of measurement that can be made with the instrument.

DISPLAY GROUP KEYS

The keys in this group determine the number of measurements to be displayed, how they are shown, and which is currently active (controllable by the front panel keys / keyboard). Only the [DISPLAY] key has an associated menu structure.

[SELECT MEAS] key

[SELECT MEAS] key is used to select one of the displayed measurements to be the active measurement within the active channel. This is the measurement currently controlled by the front panel keys, and all measurement specific functions apply to the active measurement. Pressing this key cycles through the displayed measurements, making each one in turn the active measurement, which is indicated by surrounding the trace information area with a red box outline. The currently displayed menu will change to the equivalent menu for the type of the new active measurement.

[SWITCH CHANNEL] key

The [SWITCH CHANNEL] key selects either Channel 1 or Channel 2 to be the active channel. This is the channel currently controlled by the front panel keys. All channel specific functions apply to the active channel. The currently displayed menu will change to the equivalent menu for the mode of the new active channel.

[DISPLAY] key

The [DISPLAY] key presents the Display menu, which enables the measurements within a channel to be turned on and off. It also allows selection of dual channel display and channel coupling.

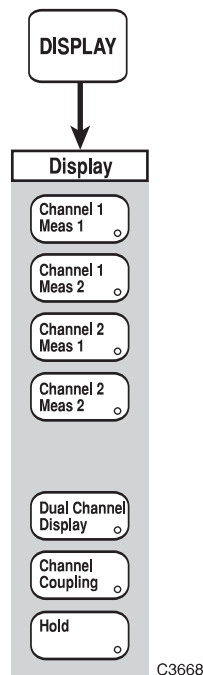

Fig. 3-10 DISPLAY menu

DISPLAY

Display

This menu is used to select single or dual channel operation, which measurements are to be displayed, and to turn channel coupling on/off. A measurement hold facility is also provided.

**Channel 1
Meas 1**

Turns measurement 1 in channel 1 on or off. Since at least one measurement must be displayed in a channel, turning off measurement 1, when it is the only measurement displayed, will automatically turn on measurement 2.

This soft key is unselectable if the channel is not currently being displayed.

**Channel 1
Meas 2**

Turns measurement 2 in channel 1 on or off. Since at least one measurement must be displayed in a channel, turning off measurement 2, when it is the only measurement displayed, will automatically turn on measurement 1.

This soft key is unselectable if the channel is not currently being displayed.

**Channel 2
Meas 1**

Turns measurement 1 in channel 2 on or off. Since at least one measurement must be displayed in a channel, turning off measurement 1, when it is the only measurement displayed, will automatically turn on measurement 2.

This soft key is unselectable if the channel is not currently being displayed.

**Channel 2
Meas 2**

Turns measurement 2 in channel 2 on or off. Since at least one measurement must be displayed in a channel, turning off measurement 2, when it is the only measurement displayed, will automatically turn on measurement 1.

This soft key is unselectable if the channel is not currently being displayed.

**Dual Channel
Display**

Toggles between dual channel and single channel display.

**Channel
Coupling**

Toggles the channel coupling facility on or off.

See page 3-17 for an explanation of channel coupling.

This soft key is only selectable if the channels are the same type.

Hold

Used to hold (freeze) the display of the active measurement. This is useful, for example, if the display is to be photographed. Also, in Spectrum Analyzer channel mode, if need to listen to a demodulated signal continuously, rather than in short bursts, this may be done by putting all of the measurements on hold (*see Spectrum Analyzer, Demodulation menu, page 3-123*).

If a trace is held, changes to parameters, such as format and scaling, will cause the trace to be refreshed from stored data. Pressing the [*Hold*] key again will restore normal operation, as will changing the channel mode or channel domain.

A held measurement is indicated on the display by an '**H**' flag in the trace information area.

CHANNEL MODE GROUP KEYS

[SCALAR] key

The [SCALAR] key provides access to the series of menus illustrated in Figs. 3-14 to 3-16, and are used to define and set up the scalar measurement and apply various functions to aid examination of the results.

If the active channel is not currently Scalar, pressing this key defines it as a scalar channel containing measurement 1 (with channel specific parameters set to default values). Confirmation will be requested before the channel mode is changed and the top level menu displayed.

The current values or states for the major measurement functions of the active channel are displayed in specific locations on the screen (see 'Display' earlier in this chapter).

SCALAR

Scalar

See Fig. 3-14. This menu and its sub-menus are used to set up the instrument to make scalar measurements.

The user can specify whether the system is to measure the absolute power level of a single input, or the ratio of two input power levels, and whether correction is to be applied to the input(s). Facilities are provided for performing measurements on devices that provide frequency or power conversion, and for specifying the x-axis annotation. The menu can also be used to apply averaging, smoothing or limit checking to the measurement. Either AC or DC detection can be selected.

**Input
Selection**

Leads to the Input Selection menu.
See page 3-56.

**Conversion
Measurements**

Leads to the Conversion Meas menus. One of two menus will be displayed, depending on whether the source mode is frequency sweep or power sweep. Frequency sweep mode is required when making measurements on frequency conversion devices; power sweep mode is used for power conversion measurements.
See pages 3-58 and 3-65.

**Group
Delay**

Leads to the Group Delay menu.
See page 3-66.

Averaging

Leads to the Averaging menu.
See page 3-68.

**Restart
Averaging**

Restarts the averaging process, for the currently active trace. This is the same as the *[Restart Averaging]* soft key in the Averaging menu,
Unselectable if averaging is off.

Smoothing

Leads to the Smoothing menu, which enables smoothing to be applied to the trace data.
See page 3-69.

**Limit
Checking**

Leads to the Lim Checking menu, which enables the displayed trace to be compared with user-defined limits.
See page 3-70.

More

Leads to the second page of the Scalar menu.
See page 3-55.

SCALAR

More

Scalar

See Fig. 3-14. This is a continuation of the previous menu.

**X-axis
Annotation**

Leads to the X-axis Annot menu.
See page 3-78.

**Input
Set-up**

Leads to the Input Set-up menu, which enables the user to set up the input configuration and to compensate for detector characteristics.
See page 3-79.

**AC
Detection**

Selects AC detection mode for scalar measurements. With AC detection, the RF output to the DUT is modulated by a square wave, and the resulting pulsed RF output from the DUT is demodulated and processed in such a way that the effects of zero drift and interfering signals are effectively cancelled. The AC mode therefore gives more accurate results for low signal level swept measurements.

The AC detection mode applies instrument-wide.

**DC
Detection**

Selects DC detection mode for scalar measurements. In the DC detection mode, an unmodulated RF signal is used and the detector simply converts the incident RF to an equivalent DC output. This mode will have to be used, for example, when measuring amplifiers with automatic gain control which may behave differently in the presence of amplitude modulated signals

The DC detection mode applies instrument-wide.

**Return to
Prior Menu**

Returns to the first page of the Scalar menu.

SCALAR

Input
Selection**Input Selection**

See Fig. 3-14. This menu is used to specify how the 6800A inputs are to be used in the measurement of power, and to access the Group Delay measurement functions (if this option is fitted).

Soft keys [A], [B], and [C] enable the power level at a selected input to be measured. The power level can be displayed in dBm, Watts or Volts, as selected from the Scale / Format menu ([SCALE / FORMAT] key).

[A/C] and [B/C] enable the ratio of the power levels at two of the inputs to be measured. The power ratio can be displayed in dB or VSWR, as selected from the Scale / Format menu.

For 6840A series instruments, the menu also allows the spectrum analyzer receiver to be used for making frequency selective power measurements, either by itself or ratioed with input C.

A	Selects input A for power measurement.
B	Selects input B for power measurement.
C	Selects input C for power measurement.
A/C	Selects input A / input C for power ratio measurement.
B/C	Selects input B / input C for power ratio measurement.
Tuned Input	Leads to the Tuned Input menu. <i>See page 3-57.</i>
Return to Scalar	Returns to the Scalar menu.

SCALAR

Input Selection

Tuned Input

Tuned Input

See Fig. 3-14. This menu enables the spectrum analyzer receiver to be used in place of a detector when making scalar measurements.

Tuned Input

Selects the spectrum analyzer receiver for frequency selective power measurements. The swept frequency range of the spectrum analyzer receiver is defined by the displayed (source) frequency range, clipped, if necessary, to the spectrum analyzer frequency limits.

The sensitivity of the spectrum analyzer receiver is set using the [Set Operating Signal Level] soft key; the Resolution Bandwidth of the receiver is set using the [Set Res BW]. The other receiver parameters are set automatically, based on the displayed frequency range and the sweep time defined for the scalar channel,

This soft key is only present on 6800A versions that include a spectrum analyzer (6840A series).

Tuned Input / C

Selects the spectrum analyzer receiver / input C for power ratio measurements.

This soft key is only present on 6800A versions that include a spectrum analyzer (6840A series).

Set Operating Signal Level

Sets the sensitivity of the spectrum analyzer receiver (equivalent to the [Set Ref Level] soft key in the Spectrum menu).

dBm & dBµV formats

Rotary Control	✓	Step Keys	✓	=Marker	✓	Numeric Pad	✓	Terminator	Any
----------------	---	-----------	---	---------	---	-------------	---	------------	-----

Volts format

Rotary Control	✓	Step Keys	✓	=Marker	✓	Numeric Pad	✓	Terminator	10-
----------------	---	-----------	---	---------	---	-------------	---	------------	-----

Set Res BW

Allows the user to enter a value for the resolution bandwidth.

Rotary Control	✓	Step Keys	✓	=Marker	✗	Numeric Pad	✗	Terminator	✗
----------------	---	-----------	---	---------	---	-------------	---	------------	---

Note The numeric pad cannot be used as the parameter is only settable in a 1, 3, 10... sequence.

Return to Input Sel

Returns to the Input Selection menu.

SCALAR

Conversion
Measurements**Conversion Meas**
(Frequency sweep)

See Fig. 3-15. This menu facilitates conversion loss/gain measurements on frequency translation devices such as mixers, down-converters and up-converters.

Measurements can be made on two types of frequency translation devices, selected by pressing the [Conv Meas Set-up] or [Mixer Meas Set-up] soft keys. The first type of measurement is for devices where the local oscillator (LO) input is a fixed frequency. The second is for mixers, which have a variable LO input. For these devices, there is an offset and/or scale factor between the RF output of the source and the displayed frequencies. The above soft keys lead to menus that can be used to set up the offset and scaling for the measurements by specifying any two of the LO, input and output frequencies.

The Advanced Set-up sub-menu allows an offset and scale factor to be entered for translating between displayed frequencies and the frequencies generated by the source at the RF output connector.

**Conv Meas
Set-up**

Leads to the Conv Meas menu.
See page 3-59.

This soft key is not present if the source mode is power sweep.

**Mixer Meas
Set-up**

Leads to the Mixer Meas menu.
See pages 3-62 and 3-63.

This soft key is not present if the source mode is power sweep.

**Apply
Scale/Offset**

Toggles the frequency scaling/offset function on or off. This soft key is the same as that in the Advanced Set-up menu. When it is turned on, it disables the User Set Annotation function (X-axis Annot menu, page 3-78)

**Advanced
Set-up**

Leads to the Advanced Set-up menu.
See pages 3-64.

**Return to
Scalar**

Returns to the Scalar menu.

SCALAR

Conversion
MeasurementsConv Meas
Set-upConv Meas

See Fig. 3-15. This menu enables conversion loss/gain measurements to be made on frequency translation devices where the LO is a fixed frequency.

The frequency range displayed on the x-axis (device output) can be scaled/offset from the 6800A source frequency range (device input). This menu enables the scaling and offset values to be set indirectly by specifying the device parameters.

The device type must be specified first, which is done by activating the Mixer Type field and using the [Upconverter] or [Downconverter] soft keys. The device parameters are entered into the appropriate fields that are displayed (see below); the [↑] and [↓] soft keys are used to make the required field active. For an up-converter, it is usual to enter the input frequency range and local oscillator (LO) frequency; the 6800A then calculates the output frequency range. For a down-converter, the output and LO are entered and the input is calculated. However, it is possible to enter any two of the three frequency parameters and the 6800A calculates the third.

The instrument setup displayed in the lower half of the form will change accordingly. For these conversion measurements, the offset will be equal to the local oscillator frequency and the scaling will be unity.

Frequency conversion devices produce two new frequencies: the sum of the local oscillator and input frequencies (upper sideband) and the difference between them (lower sideband). When testing an up-converter the appropriate sideband can be selected for display by means of the [Upper] and [Lower] soft keys (available when the Sideband field is made active). This can be useful if the up-converter has an output filter to remove the unwanted sideband; this may be displayed in order to determine how well it is rejected. The [Upper] and [Lower] soft keys perform a different function when a down-converter is measured. In this case they are used to select which of the two possible input frequency ranges are used to produce the specified output frequency range; the source is set to sweep over this range.

The Input Level parameters set the output power of the source (internal or 6800A controlled external source), and should be set to a value that does not overload the inputs to the device. If the Tuned Input mode is used, values can also be entered for Output Level or Approximate Gain/Loss of the device if either of these are known. The Output Level figure determines the sensitivity of the tuned input (i.e. the spectrum analyzer receiver); this is equivalent to using [Set Operating Signal Level] in the Tuned Input menu. This value is shown at the bottom of the Conversion Measurement Set-up box.

Measurements can also be made using an external source (e.g. a second 6800A) connected to the instrument via the GPIB interface. This can be set up using the 6800A menus and used as the local oscillator for the device.

**Cntr /
Span**

When [Cntr / Span] is enabled, the input and output frequency ranges are entered and displayed in centre / span format. When it is disabled, frequency ranges are in start / stop format.



Makes the previous field on the display the active field.



Makes the next field on the display the active field.

The functions of the next two soft keys depend on which field is active.

Active field is 'Mixer Type'

- Upconverter** Specifies that the device to be measured is an up-converter (output frequency > input frequency).
- Downconverter** Specifies that the device to be measured is down-converter (output frequency < input frequency).

Active field is 'Sideband'

- Upper** For an up-converter, specifies that the upper sideband frequencies are to be displayed. For a down-converter, specifies the higher of the two frequencies that will produce the specified output frequency.
- Lower** For an up-converter, specifies that the lower sideband frequencies are to be displayed. For a down-converter, specifies the lower of the two frequencies that will produce the specified output frequency.

External Source Toggles external source control on or off. When turned on, the CW frequency and power level of an external source can be set up via the menus in the usual way, which are passed to the external source via the GPIB interface. This can then be used for the local oscillator signal. This function is turned off if the LO is internal to the DUT (and cannot be altered), or if an independent source is used for the LO.

External Src Select Leads to the External Src menu.
See page 3-61

Return to Conv Meas Returns to the Conversion Meas menu.

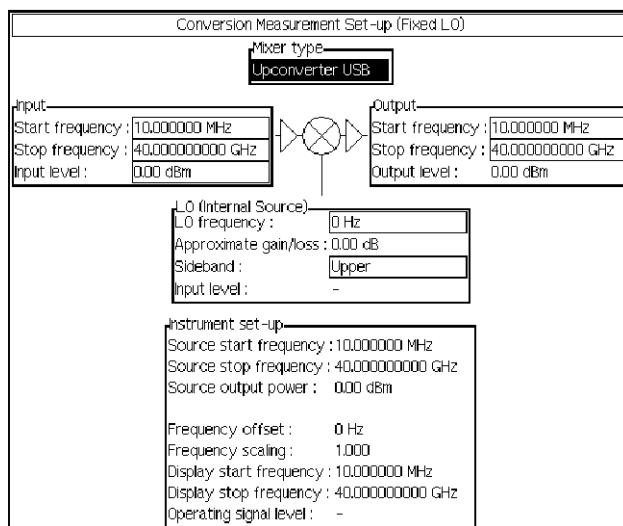

B5089

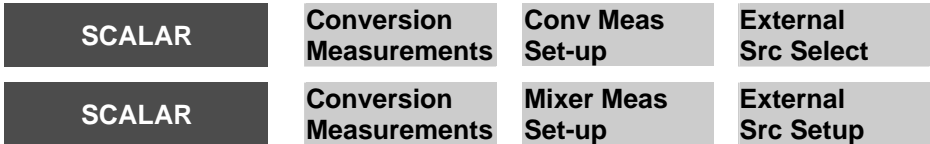

External Src See Fig. 3-15. This menu is used to set up the external source that is to be used for the measurement.

Select Source Leads to the Select Src menu. See page 3-61.

Ext Source Address Enables the GPIB address for the external source to be set up by entering a number between 0 and 30.

Rotary Control X Step Keys X =Marker X Numeric Pad √ Terminator Any

Return to Conv Meas Returns to the Conv Meas menu.



Select Src See Fig. 3-15. This menu is used to select the external source that is to be used for the measurement.

Instruments that can be used have associated data files that are stored within the 6800A. The allowed instruments are listed on the display, the appropriate one is selected using the following soft keys.

Select Source Enables the 6800A to use the highlighted instrument as the external source.

↑ Highlights the previous entry in the external source list. The list automatically scrolls, if necessary, when the highlight reaches the top of the list.
This soft key will be unselectable if the highlight is at the beginning of the list.

↓ Highlights the next entry in the external source list. The list automatically scrolls, if necessary, when the highlight reaches the top of the list.
This soft key will be unselectable if the highlight is at the end of the list.

Install Src .Used to add a data file for an instrument to be used as an external source.

Return to External Src Returns to the External Src menu.

SCALAR

Conversion Measurements

Mixer Meas Set-up

Mixer Meas
(Active field = 'Mixer Type')

See Fig. 3-15. This menu enables conversion loss/gain measurements to be made on frequency translation devices where the LO is a variable frequency.

The x-axis in these measurements represents the frequency range of the swept RF input, so the display shows how the amplitude of the IF output varies with the RF input frequency.

The mixer type must be specified first, which is done by activating the Mixer Type field and using the [Upconverter] or [Downconverter] soft keys. Mixer parameters are entered into the appropriate fields that are displayed (see below); the [↑] and [↓] soft keys are used to make the required field active.

For an up-converter, the input frequency range and local oscillator (LO) frequency are entered and the 6800A calculates the output frequency range. For a down-converter, the output and LO are entered and the input is calculated. However, it is possible to enter any two of the three frequency parameters and the 6800A calculates the third.

The instrument setup displayed in the lower half of the form will change accordingly. For these measurements the offset corresponds to the IF and the scaling will be unity.

A mixer produces two new frequencies: the sum of the local oscillator and input frequencies (upper sideband) and the difference between them (lower sideband). When testing an up-converter the appropriate sideband can be selected for display by means of the [Upper] and [Lower] soft keys (available when the Sideband field is made active). This can be useful if the up-converter has an output filter to remove the unwanted sideband; this may be displayed in order to determine how well it is rejected. The [Upper Sideband] and [Lower Sideband] soft keys perform a different function when a down-converter is measured. In this case they are used to select which of the two possible input frequency ranges are used to produce the specified output frequency; the source is set to sweep over this range.

The Input Level parameters set the output power of the source (internal or 6800A controlled external source), and should be set to a value that does not overload the RF and LO inputs to the mixer. If the Tuned Input mode is used, values can also be entered for Output Level or Approximate Gain/Loss of the mixer if either of these are known. The Output Level figure determines the sensitivity of the tuned input (i.e. the spectrum analyzer receiver); this is equivalent to using [Set Operating Signal Level] in the Tuned Input menu. This value is shown at the bottom of the Mixer Measurement Set-up box.

The soft keys below are displayed if the active field is 'Mixer Type'; the following menu shows the soft keys that are displayed if one of the other fields is active.



Makes the previous field on the display the active field.



Makes the next field on the display the active field.

Upconverter

Specifies that the device to be measured is an up-converter (output frequency > input frequency).

Downconverter

Specifies that the device to be measured is down-converter (output frequency < input frequency).

Upper Sideband

For an up-converter, specifies that the upper sideband frequencies are to be displayed. For a down-converter, specifies the higher of the two frequencies that will produce the specified output frequency.

Lower Sideband

For an up-converter, specifies that the lower sideband frequencies are to be displayed. For a down-converter, specifies the lower of the two frequencies that will produce the specified output frequency.

Return to Conv Meas

Returns to the Conversion Meas menu.

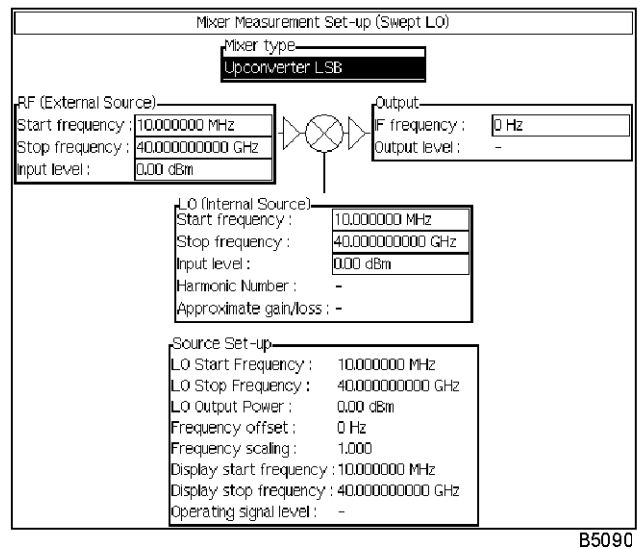

B5090

SCALAR

Conversion Measurements

Mixer Meas Set-up

Mixer Mea
(Active field = 'RF', 'Output' or 'LO')

See Fig. 3-15.



Makes the previous field on the display the active field.



Makes the next field on the display the active field.

External Source

Toggles external source control on or off. When turned on, the external source parameters can be set up via the menus in the usual way, which are passed to the external source via the GPIB interface. The external source can be used for the LO or RF Input, as selected by the [External Source LO] and [External Source RF] soft keys.

Cntr / Span

When [Cntr / Span] is enabled, frequency ranges are entered and displayed in centre / span format. When it is disabled, frequency ranges are in start / stop format.

External Src Setup

Leads to the External Src menu.
See page 3-61

External Source LO Specifies that the external source is to be used as the local oscillator input to the mixer.

External Source RF Specifies that the external source is to be used as the RF input to the mixer.

Return to Conv Meas Returns to the Conversion Meas menu.



Advanced Set-up (Frequency sweep) *See Fig. 3-15. This menu enables direct setting of scaling and offset between the source frequency range and the displayed frequency range during scalar measurements.*

This may be required, for example, if the RF is applied to the DUT via a frequency conversion device. The display (i.e. x-axis annotation) can then be set to show the actual frequency applied to the DUT, rather than the source output frequency. This menu can also be used for conversion loss/gain measurements, as an alternative to the method described above; the displayed frequency range can be scaled/offset from the source range so that the frequency range of the output signal is displayed.

The order in which offset and scaling are applied can be selected:

When the *[Apply Scale then Offset]* soft key is pressed::

$$f_{\text{displayed}} = (f_{\text{source}} \times \text{scale factor}) + f_{\text{offset}}$$

When the *[Apply Offset then Scale]* soft key is pressed::

$$f_{\text{displayed}} = (f_{\text{source}} + f_{\text{offset}}) \times \text{scale factor}$$

The default values are: scale factor = 1, $f_{\text{offset}} = 0$.

Set Frequency Scaling This soft key allows entry of a scaling factor.

Rotary Control	✓	Step Keys	✓	=Marker	✗	Numeric Pad	✓	Terminator	Any
----------------	---	-----------	---	---------	---	-------------	---	------------	-----

Set Frequency Offset Allows entry of a frequency offset.

Rotary Control	✓	Step Keys	✓	=Marker	✗	Numeric Pad	✓	Terminator	10+
----------------	---	-----------	---	---------	---	-------------	---	------------	-----

Apply Scale/Offset Toggles the scale/offset function on or off.

Apply Scale then Offset Multiplies the source frequency by the scale factor then adds the offset..

Apply Offset then Scale Adds the offset value to the source frequency then multiplies the result by the scale factor..

Return to Conv Meas Returns to the Conversion Meas menu.

SCALAR

Conversion Measurements

Conversion Meas
(Power sweep)

See Fig. 3-15. This menu provides frequency and power offset functions for swept power measurements at the source frequency and also where the source and measuring frequencies are offset.

Apply Offset

Toggles the power offset function on or off. When it is turned on, it disables the User Set Annotation function (X-axis Annot menu, page 3-78)

Advanced Set-up

Leads to the Advanced Set-up menu.
See page 3-65

Return to Scalar

Returns to the Scalar menu.

SCALAR

Conversion Measurements

Advanced Set-up

Advanced Set-up
(Power sweep)

See Fig. 3-15. Used to specify the power offset.

For swept power measurements, a power offset can be applied, for translation between the source swept power range and the displayed swept power range, as follows:

$$P_{\text{displayed}} = P_{\text{source}} + P_{\text{offset}}$$

The default value is $P_{\text{offset}} = 0$ dB.

Set Frequency Scaling

Allows entry of a scaling factor for a power sweep through a frequency multiplier.

Rotary Control	✓	Step Keys	✓	=Marker	✗	Numeric Pad	✓	Terminator	Any
----------------	---	-----------	---	---------	---	-------------	---	------------	-----

Set Frequency Offset

Allows entry of a frequency offset for a power sweep through a frequency converter.

Rotary Control	✓	Step Keys	✓	=Marker	✗	Numeric Pad	✓	Terminator	Any
----------------	---	-----------	---	---------	---	-------------	---	------------	-----

Apply Scale/Offset

Toggles the power offset function on or off.

Apply Scale then Offset

Multiplies the source frequency by the scale factor then adds the offset.

Apply Offset then Scale

Adds the offset value to the source frequency then multiplies the result by the scale factor.

Set Power Offset

Allows entry of a power offset.

Rotary Control	✓	Step Keys	✓	=Marker	✗	Numeric Pad	✓	Terminator	Any
----------------	---	-----------	---	---------	---	-------------	---	------------	-----

Return to Conv Meas

Returns to the Conversion Meas menu.

SCALAR

Input Selection

Group Delay

Group Delay

See Fig. 3-14. This menu enables group delay measurements to be performed on a communications link or signal processing device. This facility is only available if the Group Delay option has been fitted.

The results of the group delay measurement depend upon the *aperture* setting (which is the bandwidth of the modulated signal). Over this aperture, fine variations in group delay are averaged out. Reducing the aperture will reduce the smoothing effect on the group delay trace, at the expense of greater measurement noise. A wider aperture reduces noise but results in a loss of fine variations in group delay. The bandwidth of a frequency modulated signal depends on both the modulating frequency and FM deviation. The instrument selects these parameters automatically such that the Aperture is the maximum possible while not exceeding 3% of the displayed frequency sweep (span), up to a maximum of 3 MHz. This should avoid excessive smoothing effects. The values are selected according to the following table:

Range	FM Deviation	Aperture
1µs	1 MHz	3 MHz (max)
1µs	500 kHz	2 MHz
1µs	200 kHz	1 MHz
2µs	100 kHz	500 kHz
5µs	100 kHz	400 kHz
5µs	40 kHz	200 kHz
10µs	20 kHz	100 kHz

Setting the Range is equivalent to setting the source modulation frequency. For example, ±1 µs (2 µs full screen) corresponds to a modulation frequency of $1/2 \times 10^{-6} = 500$ kHz; ±10 µs (20 µs full screen) corresponds to 50 kHz.

If required, this automatic (span dependent) setting can be overridden by uncoupling the aperture parameter using [Coupled Aperture] and entering the required value with [Set Aperture].

Note that a new calibration will be required whenever the Range or FM deviation are changed.

Group Delay

Initiates the group delay measurement once the settings have been specified using the following soft keys.

Set Operating Signal Level

As the group delay measurement uses the spectrum analyzer input, this soft key is used to set the sensitivity of the spectrum analyzer receiver, so as not to overload the front end (equivalent to the [Set Ref Level] soft key in the Spectrum menu).

Rotary Control	√	Step Keys	√	=Marker	√	Numeric Pad	√	Terminator	Any
----------------	---	-----------	---	---------	---	-------------	---	------------	------------

Coupled Aperture

Turns aperture coupling on and off. When enabled, the Aperture setting is dependent on the frequency span. When disabled, the Aperture can be set explicitly using the soft key below to override the automatic setting. .

Set Aperture Allows the user to display the current Aperture setting, or to enter a new value. Changing the Aperture overrides the automatic settings for Range and FM Deviation, and are set according to the previous table.

Rotary Control	✓	Step Keys	✓	=Marker	✗	Numeric Pad	✗	Terminator	✗
----------------	---	-----------	---	---------	---	-------------	---	------------	---

Note The numeric pad cannot be used as the parameter is only settable to one of the following seven values: 100 kHz, 200 kHz, 400 kHz, 500 kHz, 1 MHz, 2 MHz and 3 MHz.

Set Range Allows the user to display the current group delay measurement range, or to enter a new value. Changing this parameter turns off aperture coupling (not dependent on span). The Aperture value is re-calculated and can be displayed by pressing the [Set Aperture] soft key.

Rotary Control	✓	Step Keys	✓	=Marker	✗	Numeric Pad	✗	Terminator	✗
----------------	---	-----------	---	---------	---	-------------	---	------------	---

Note The numeric pad cannot be used as the parameter is only settable to 1, 2, 5 or 10 μs.

Set FM Deviation Allows the user to display the current deviation of the frequency modulated source, or to enter a new value. Changing this parameter turns off aperture coupling (not dependent on span). The Aperture value is re-calculated and can be displayed by pressing the [Set Aperture] soft key.

Rotary Control	✗	Step Keys	✗	=Marker	✗	Numeric Pad	✓	Terminator	10+
----------------	---	-----------	---	---------	---	-------------	---	------------	-----

Zeroing Leads to the Zeroing menu.
See page 3-67.

Return to Input Sel Returns to the Input Selection menu.



Zeroing *See Fig. 3-14. The zeroing function only applies to group delay measurements above 3 GHz. It is used to compensate for errors due to temperature changes affecting the hardware.*

Since the increase in stability provided by the zeroing function is at the expense of measurement noise, a facility is provided to disable zeroing.

Autozeroing When autozeroing is enabled, zeroing is always used on the 1 μs range, and disabled for all other ranges, where the additional noise may be objectionable. This is the default setting.

Zeroing On Forces the measurement to use zeroing on all ranges .

Zeroing Off Disables zeroing on all ranges. This can be selected to reduce measurement noise but at the expense of long term stability.

Return to Group Delay Returns to the Group Delay menu.

SCALAR

Averaging

Averaging

See Fig. 3-14. This menu enables averaging to be applied to the measurement data. Averaging is used to reduce the amount of noise on a trace. The minimum amount of averaging should be selected, to reduce noise to an acceptable level, in order to maintain a sufficiently fast response.

Each new sweep is averaged into the trace until the sweep count is equal to the user-entered average number, for a fully averaged trace. This condition is indicated by the 'A' flag in the relevant trace information area. The flag is in lower case until this condition is reached. It is absent if the averaging function is turned off.

The amount of averaging is set by using [Set Average Number]. The averaging process can be re-started by using [Restart Averaging] soft key.

Fig. 3-11 illustrates the effect of averaging on a typical measurement trace.

Averaging

.Toggles averaging on or off, for the currently active trace.

Set Average Number

Enables entry of the average number to be used in the averaging function, for the currently active trace. When using the rotary control, and step keys, the average number will be incremented in powers of 2.

Rotary Control	√	Step Keys	√	=Marker	×	Numeric Pad	√	Terminator	Any
----------------	---	-----------	---	---------	---	-------------	---	------------	-----

Restart Averaging

Restarts the averaging process, for the currently active trace.

Unselectable if averaging is off.

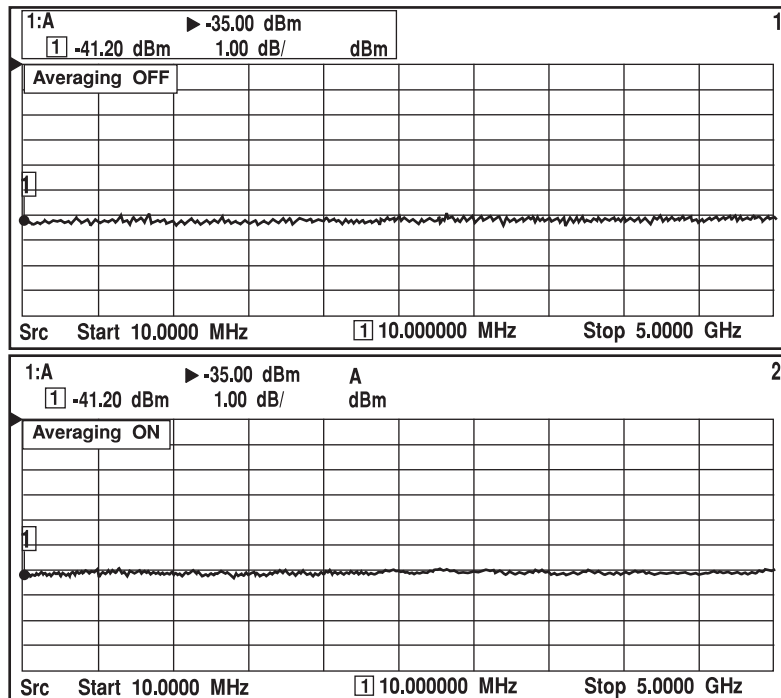

C4961

Fig. 3-11 Effect of averaging on a trace

SCALAR

Smoothing

Smoothing

See Fig. 3-14. Smoothing is used to filter active trace data by performing a ‘moving average’ on the data over a specified percentage of the sweep span. The parameter that specifies the percentage of the trace to be averaged for each data point is called the smoothing aperture.

Smoothing should be used to reduce ripple on a trace, e.g. to reduce relatively small peak-to-peak noise values on broadband measured data. Do not use smoothing for measurement of high resonance devices or other devices with wide variations in the trace, as it will introduce errors into the measurement.

Fig. 3-12 illustrates the effect of smoothing on a typical measurement trace.

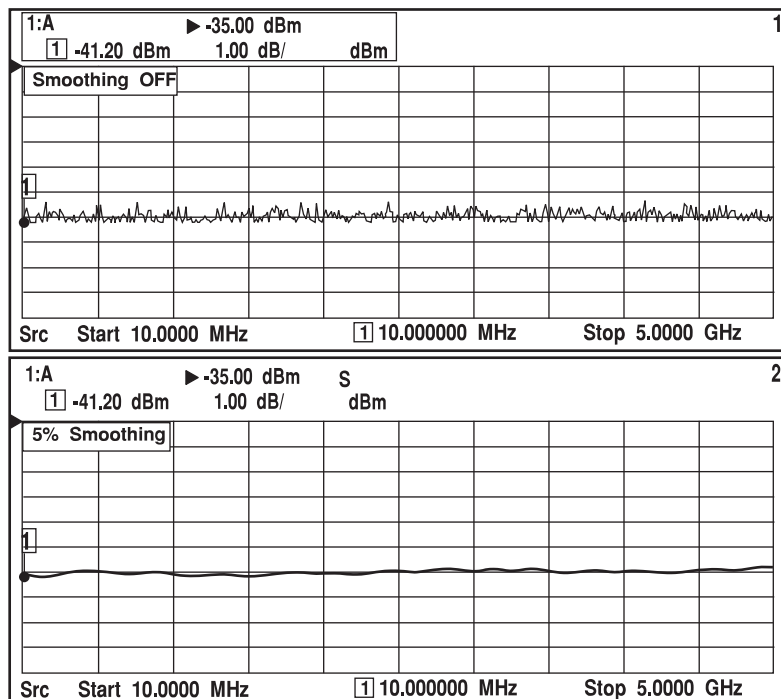

C4962

Fig. 3-12 Effect of smoothing on a trace

Smoothing

Toggles smoothing on or off for the currently active trace. If smoothing is applied to a trace, it is indicated in the relevant trace information area by an 'S' flag.

Set Aperture

Enables selection of the smoothing aperture for the currently active trace. The smoothing aperture is a percentage of the span swept, and can be set between 1% and 20%.

Rotary Control	√	Step Keys	√	=Marker	×	Numeric Pad	√	Terminator	Any
----------------	---	-----------	---	---------	---	-------------	---	------------	-----

Return to Scalar

Returns to the Scalar menu.

SCALAR

Limit
CheckingLim Checking

See Fig. 3-16. This menu enables a limit checking facility to be implemented, allowing any displayed trace to be compared against complex limit lines.

The limit type can be defined as either:

- Upper limit only
- Lower limit only
- Both upper and lower limits

Limit lines are defined in the form of a *limit specification*, with each specification comprising up to 12 horizontal segments. Each segment is a portion of the x-domain, and can be defined with the following parameters:

- Start and Stop domain values
- Upper and lower limits corresponding to the start domain value
- Upper and lower limits corresponding to the stop domain value

Two types of segment are available:

Flat line. Limit values are constant with frequency or other domain value; it is not necessary to enter limits for both ends of the line.

Sloping line. Limit values change linearly with the domain value; intermediate values are obtained by linear interpolation.

**Limit
Checking**

Toggles the limit checking facility on or off for the currently active trace.

**Assign
Spec**

Leads to the Assign Lim Spec menu, which is used to assign a limit checking specification to a trace.

See page 3-71.

**Edit
Spec**

Leads to the Limit Editor menu.

See page 3-72.

**Print
Spec**

Leads to the Print Lim Spec menu.

See page 3-77.

**Return to
Scalar**

Returns to the Scalar menu.

SCALAR

Limit
CheckingAssign
Spec

Assign Lim Spec See Fig. 3-16. This menu is used to assign a limit specification to the active trace.

A form is displayed listing the identities of the available limit specifications. To assign a specification, it is selected from the list.

As well as the specification id, its associated date and time stamp are also displayed in the list. A section at the bottom of the form will display the descriptive text for the currently selected specification in the list, and states whether or not it is password protected.

For limit specifications employing domain offsets with respect to a centre value, the limit specification will be applied about the displayed centre frequency.

Select Assigns the selected limit checking specification to the currently active trace.

↑

Selects the previous entry in the list of limit specifications. The list automatically scrolls, if necessary, when the highlight reaches the top of the list.

This soft key will be unselectable if the highlight is at the beginning of the list.

↓

Selects the next entry in the list of limit specifications. The list automatically scrolls, if necessary, when the highlight reaches the bottom of the list.

This soft key will be unselectable if the highlight is at the end of the list.

USB Memory

When selected, the list of stores shown will be those found in the current directory on the removable storage currently inserted in the USB port. As well as the list of stores any directories found in the current directory will also be shown. The [ENTER / =MKR] key is used to change directory.

Note Access to the removable storage is global to the instrument and the state is preserved across visits to all menus that can access the USB ports.

**Return to
Lim Checking**

Returns to the Limit Checking menu.

SCALAR

Limit Checking

Edit Spec

Limit Editor

See Fig. 3-16. This menu is used to create a new limit checking specification or to edit an existing one.

A form is displayed on the screen, showing the contents of the limit checking specification, in segment order. Each segment is defined by some or all of the following parameters, depending on the segment type:

Segment number, start domain value, start upper limit, start lower limit, stop domain value, stop upper limit and stop lower limit.

Also shown on the form is the limit type, i.e. upper limit only, lower limit only or both upper and lower limits, and whether absolute or offset domain values are used (Limit Type menu).

Limit Editor						
Store Name: spec						
Limit Type : Absolute, upper only						
	Flat/Slp	Start	Upper	Lower	Stop	Upper Lower
1.	Flat	8.0G	-60.0	-	8.35G	- -
2.	Slope	8.35G	-60.0	-	8.75G	2.0 -
3.	Flat	8.75G	2.0	-	9.25G	- -
4.	Slope	9.25G	2.0	-	9.65G	-60.0 -
5.	Flat	9.65G	-60.0	-	10.0G	- -
6.	-	-	-	-	-	- -
7.	-	-	-	-	-	- -
8.	-	-	-	-	-	- -
9.	-	-	-	-	-	- -
10.	-	-	-	-	-	- -
11.	-	-	-	-	-	- -
12.	-	-	-	-	-	- -

B4351

Fig. 3-13 Limit checking specification form

Limit Type Leads to the Limit Type menu.
See page 3-73.

Edit Segments Leads to the Edit Segments menu.
See page 3-74.

Save Saves the current limit specification, using the same storage location. All segment values are first of all checked for consistency, as in the Edit Segments menu. If the checks fail a message will be displayed; the error must be corrected before the will be accepted.

Save As Leads to the Save Spec As menu. A consistency check is first of all performed, as above.
See page 3-75.

New Spec Used to create a new limit checking specification by entering data into blank fields. If the current specification has changed since it was last saved, the user will be given the opportunity to save it before the new specification is presented.

Select Spec Used to select another limit checking specification for editing. If the current specification has changed since it was last saved, the user will be given the opportunity to save it before the new specification is presented. Leads to the Select Spec menu.

See page 3-76.

Exit The editing function is terminated and control returned to the Lim Checking menu. If the current specification has changed since it was last saved, the user will be given the opportunity to save it before the editor is terminated.



Limit Type

See Fig. 3-16. This menu is used to set the type of limit checking, i.e. whether it is against an upper limit only, a lower limit only or both. It is also used to specify whether the domain values are to be used as absolute values or as offsets relative to the centre value of the measurement being checked. The settings specified here apply to all segments.

When the domain values are entered as offsets, the resulting limit lines will be reflected symmetrically about the centre value. In the example below, it is only necessary to specify the flat segment between the centre and offset A, and the sloped segment between offset A and offset B. When the specification is applied to a measurement, it is assumed that the lines are reflected about the centre line.

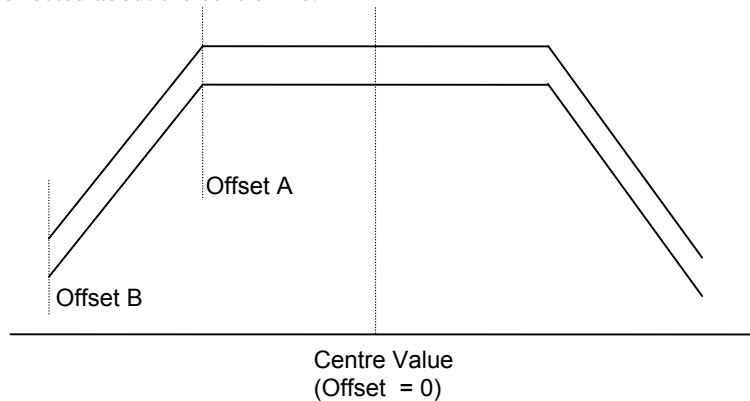

Upper and Lower Limits Sets the checking to be against an upper and lower limit.

Upper Limit Only Sets the checking to be against an upper limit only.

Lower Limit Only Sets the checking to be against a lower limit only.

Absolute Domain Values Sets the domain values to be used as absolute values.

Relative Domain Values Sets the domain values to be used as offsets relative to the centre value of the measurement.

Return to Limit Editor The editing function is terminated and control returned to the Limit Editor menu.

SCALAR

Limit
CheckingEdit
SpecEdit
Segments**Edit Segments**

See Fig. 3-16. This menu is used to define the segments that comprise the limit specification.

The [\uparrow] and [\downarrow] soft keys (or front panel step keys) are used to select a segment for editing; the [\Rightarrow] [\Leftarrow] soft keys (or rotary control) are used to select a field within a segment.

New segments are added to the end of the segment list. The start fields will be the same as the stop fields of the previous segment. Before a new segment is added, the current one is checked to ensure that the start domain value is less than the stop domain value, and that each lower limit value is less than its corresponding upper limit value. If the checks fail a message will be displayed; the error must be corrected before a new segment can be added.

Note that a flat line segment does not use the stop upper/lower values.

**Delete
Segment**

Deletes the active segment from the specification, after asking for confirmation. The segments below the active one will be moved upwards in the specification form and will be renumbered.

 \uparrow

Makes the previous segment in the specification the active segment.

 \downarrow

Makes the next segment in the specification the active segment.

 \Rightarrow

Makes the next field in the segment the active field.

 \Leftarrow

Makes the previous field in the segment the active field.

Flat

Defines the selected limit segment as a flat line.

Slope

Defines the selected limit segment as a sloping line.

**Return to
Limit Editor**

The editing function is terminated and control returned to the Limit Editor menu.

SCALAR

Limit
CheckingEdit
SpecSave
As**Save Spec As**

See Fig. 3-16. This menu is used to save the current limit specification to a location specified by the user.

A form is displayed listing the identities of the available limit specifications. To save the data to a specific limit specification, the specification name is selected from the list. Alternatively, a new specification can be created by entering a new name in the appropriate entry field.

As well as the specification id, its associated date and time stamp are also displayed in the list. A section at the bottom of the form will display the descriptive text for the currently selected specification in the list, and states whether or not it is password protected.

Save

Saves the current specification into the selected store.



Selects the previous entry in the list of specifications. The list automatically scrolls, if necessary, when the highlight reaches the top of the list.

This soft key will be unselectable if the highlight is at the beginning of the list



Selects the next entry in the list of specifications. The list automatically scrolls, if necessary, when the highlight reaches the bottom of the list.

This soft key will be unselectable if the highlight is at the end of the list

**New Store
Name**

Enables a new specification store name to be entered.

**USB
Memory**

When selected the list of stores shown will be those found in the current directory on the removable storage currently inserted in the USB port. As well as the list of stores any directories found in the current directory will also be shown. The [ENTER / =MKR] key is used to change directory.

Note Access to the removable storage is global to the instrument and the state is preserved across visits to all menus that can access the USB ports.

**Set Store
Information**

Leads to the Set Store Info menu. This menu provides the same functions as Set Store Info menu for trace memory stores.

See page 3-230.

**Return to
Limit Editor**

Returns to the Limit Editor menu.

SCALAR

Limit
CheckingEdit
SpecSelect
Spec**Select Spec**

See Fig. 3-16. This menu is used to select a limit specification to be edited.

A form is displayed listing the identities of the available limit specifications. To edit a specification, it is selected from the list.

As well as the specification id, its associated date and time stamp are also displayed in the list. A section at the bottom of the form will display the descriptive text for the currently selected specification in the list, and states whether or not it is password protected.

Select

Causes the limit specification editor to be started with the selected limit checking specification open for editing.

↑

Selects the previous entry in the list of limit specifications. The list automatically scrolls, if necessary, when the highlight reaches the top of the list.

This soft key will be unselectable if the highlight is at the beginning of the list.

↓

Selects the next entry in the list of limit specifications. The list automatically scrolls, if necessary, when the highlight reaches the bottom of the list.

This soft key will be unselectable if the highlight is at the end of the list

**Return to
Limit Editor**

Returns to the Limit Editor menu.

SCALAR

Limit
CheckingPrint
Spec**Print Lim Spec**

See Fig. 3-16. This menu is used to select a limit specification for printing.

A form is displayed listing the identities of the available limit specifications. To print a specification, it is selected from the list.

As well as the specification id, its associated date and time stamp are also displayed in the list. A section at the bottom of the form will display the descriptive text for the currently selected specification in the list, and states whether or not it is password protected.

Select

Initiates printing of the selected limit checking specification. Leads to the Confirm Print menu.

See page 3-223.

↑

Selects the previous entry in the list of limit specifications. The list automatically scrolls, if necessary, when the highlight reaches the top of the list.

This soft key will be unselectable if the highlight is at the beginning of the list.

↓

Selects the next entry in the list of limit specifications. The list automatically scrolls, if necessary, when the highlight reaches the bottom of the list.

This soft key will be unselectable if the highlight is at the end of the list.

**USB
Memory**

When selected the list of stores shown will be those found in the current directory on the removable storage currently inserted in the USB port. As well as the list of stores any directories found in the current directory will also be shown. The [ENTER / =MKR] key is used to change directory.

Note Access to the removable storage is global to the instrument and the state is preserved across visits to all menus that can access the USB ports.

**Return to
Lim Checking**

Returns to the Lim Checking menu.

SCALAR

**X-axis
Annotation**

X-axis Annot *See Fig. 3-14. This menu allows an arbitrary frequency (or power) range to be entered by the user as the x-axis annotation. This is indicated on the screen and hard copy.*

User Set Annotation Toggles User Set Annotation on or off. When it is turned on, the following soft keys are made selectable, and it also disables the Apply Scale/Offset or Apply Offset function (Conversion Meas menu, page 3-59).

The functions of the next two soft keys depend on the setting of the [Cntr / Span] soft key.

Centre / span disabled

Set Display Start This soft key enables entry of the start frequency or power.

Frequency

Rotary Control	√	Step Keys	√	=Marker	×	Numeric Pad	√	Terminator	10+
----------------	---	-----------	---	---------	---	-------------	---	------------	------------

Power

Rotary Control	√	Step Keys	√	=Marker	×	Numeric Pad	√	Terminator	Any
----------------	---	-----------	---	---------	---	-------------	---	------------	------------

This soft key will only be selectable if a Measurement Store is not being displayed.

Set Display Stop This soft key enables entry of the stop frequency or power.

Frequency

Rotary Control	√	Step Keys	√	=Marker	×	Numeric Pad	√	Terminator	10+
----------------	---	-----------	---	---------	---	-------------	---	------------	------------

Power

Rotary Control	√	Step Keys	√	=Marker	×	Numeric Pad	√	Terminator	Any
----------------	---	-----------	---	---------	---	-------------	---	------------	------------

This soft key will only be selectable if a Measurement Store is not being displayed.

Centre / span enabled

Set Display Cntr This soft key enables entry of the centre frequency or power.

Frequency

Rotary Control	√	Step Keys	√	=Marker	×	Numeric Pad	√	Terminator	10+
----------------	---	-----------	---	---------	---	-------------	---	------------	------------

Power

Rotary Control	√	Step Keys	√	=Marker	×	Numeric Pad	√	Terminator	Any
----------------	---	-----------	---	---------	---	-------------	---	------------	------------

This soft key will only be selectable if a Measurement Store is not being displayed.

Set Display Span This soft key enables entry of the frequency or power span.

Frequency

Rotary Control	√	Step Keys	√	=Marker	×	Numeric Pad	√	Terminator	10+
----------------	---	-----------	---	---------	---	-------------	---	------------	------------

Power

Rotary Control	√	Step Keys	√	=Marker	×	Numeric Pad	√	Terminator	Any
----------------	---	-----------	---	---------	---	-------------	---	------------	------------

This soft key will only be selectable if a Measurement Store is not being displayed.

Cntr / Span	When [<i>Cntr / Span</i>] is enabled, the range may be entered in centre / span form. When it is disabled, however, the range may be entered in start / stop form. <i>This soft key will only be selectable if the source is not in power sweep mode and a Measurement Store is not being displayed.</i>
Return to Scalar	Returns to the Scalar menu.

SCALAR

Input Set-up

Input Set-up See Fig. 3-14. The Input Set-up menu enables the user to set up the input offsets, and to compensate for non-ideal characteristics of detectors.

Below a certain power level, detectors are assumed to obey a square law response, where the detector output voltage is directly proportional to the input power. Above that level, deviation from the square law results in lower power readings than expected, which should be corrected by means of a table.

The supported EEPROM detectors are individually calibrated to provide linearity correction data (square-law response correction) and flatness correction data (frequency response). The data is held in the detector's EEPROM, and read by the 6800A when the detector is connected to an input.

View Connected Detectors	Displays a form on the screen showing the detector type connected to each input, and whether linearity and flatness correction are applied. Pressing the [<i>Return to Input Set-up</i>] soft key Returns to the Input Set-up menu.
Input Level Offsets	Leads to the I/p Level Offsets menu. <i>See page 3-80.</i>
Input A Correction	Leads to the Input A Corr menu. <i>See page 3-81.</i>
Input B Correction	Leads to the Input B Corr menu. <i>See page 3-81.</i>
Input C Correction	Leads to the Input C Corr menu. <i>See page 3-81.</i>
Return to Scalar	Returns to the Scalar menu.

SCALAR

Input Set-up

Input Level Offsets

I/p Level Offsets See Fig. 3-14. This menu enables power offsets to be applied to detector measurements.

The offset is effectively a fixed dB value that is added to or subtracted from the reading. Offsets are useful for compensating for attenuators or amplifiers between the DUT and the detector. Use a positive offset to compensate for attenuation and a negative offset to compensate for gain.

An 'O' flag will be displayed in the trace information area if an offset is being applied to any of the inputs taking part in the measurement.

Input A Offset

Enables the offset for Input A to be changed.

Rotary Control	X	Step Keys	X	=Marker	X	Numeric Pad	√	Terminator	Any
----------------	---	-----------	---	---------	---	-------------	---	------------	------------

Input B Offset

Enables the offset for Input B to be changed.

Rotary Control	X	Step Keys	X	=Marker	X	Numeric Pad	√	Terminator	Any
----------------	---	-----------	---	---------	---	-------------	---	------------	------------

Input C Offset

Enables the offset for Input C to be changed.

Rotary Control	X	Step Keys	X	=Marker	X	Numeric Pad	√	Terminator	Any
----------------	---	-----------	---	---------	---	-------------	---	------------	------------

Tuned Input Offset

Enables the offset for the spectrum analyzer receiver to be changed.

Rotary Control	X	Step Keys	X	=Marker	X	Numeric Pad	√	Terminator	Any
----------------	---	-----------	---	---------	---	-------------	---	------------	------------

This soft key is only present on 6800A versions that include a spectrum analyzer (6840A series).

Return to Input Set-up

Returns to the Input Set-up menu.

SCALAR

Input
Set-upInput A (B or C)
Correction

Input A (B or C) Corr *See Fig. 3-14.* These three menus are identical, and are used to enable/disable linearity and flatness correction, the data for which is held in an EPROM within the scalar measuring device. It is also possible to examine the EEPROM data, for the specified input.

In addition to the 6230A/L Series EEPROM detectors, the 6800A also supports 6240 Series Fault Locators, Autotesters (using generic correction data) and Voltage Adapter Cables.

**Linearity
Correction**

Toggles power linearity correction on or off for the input.

If an EEPROM detector is plugged into the input, and linearity correction is enabled, the linearity correction data is loaded from the EEPROM, and applied to the measurement.

If any other type of detector is connected, and linearity correction is enabled, default linearity correction is applied. The default data is applicable to the detectors used in fault location test heads.

**Flatness
Correction**

Toggles flatness correction on or off for the input.

If an EEPROM detector is plugged into the input, and flatness correction is enabled, the flatness correction data is loaded from the EEPROM, and applied to the measurement.

**Examine
EEPROM Data**

Allows examination of the EEPROM data held in the device connected to the input.

**Return to
Input Set-up**

Returns to the Input Set-up menu.

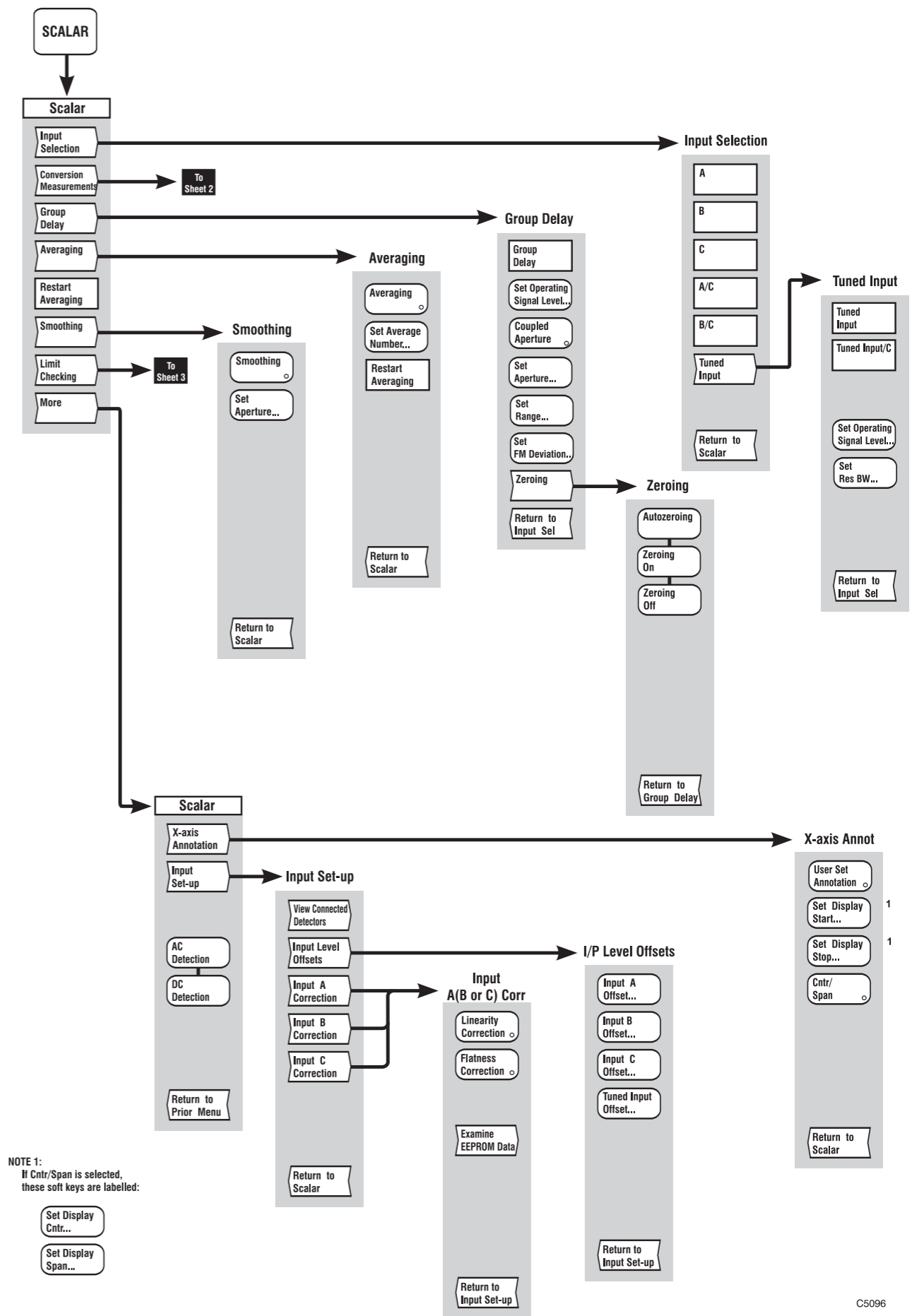

C5096

Fig. 3-14 SCALAR menus (sheet 1)

Fig. 3-14 SCALAR menus (sheet 1)

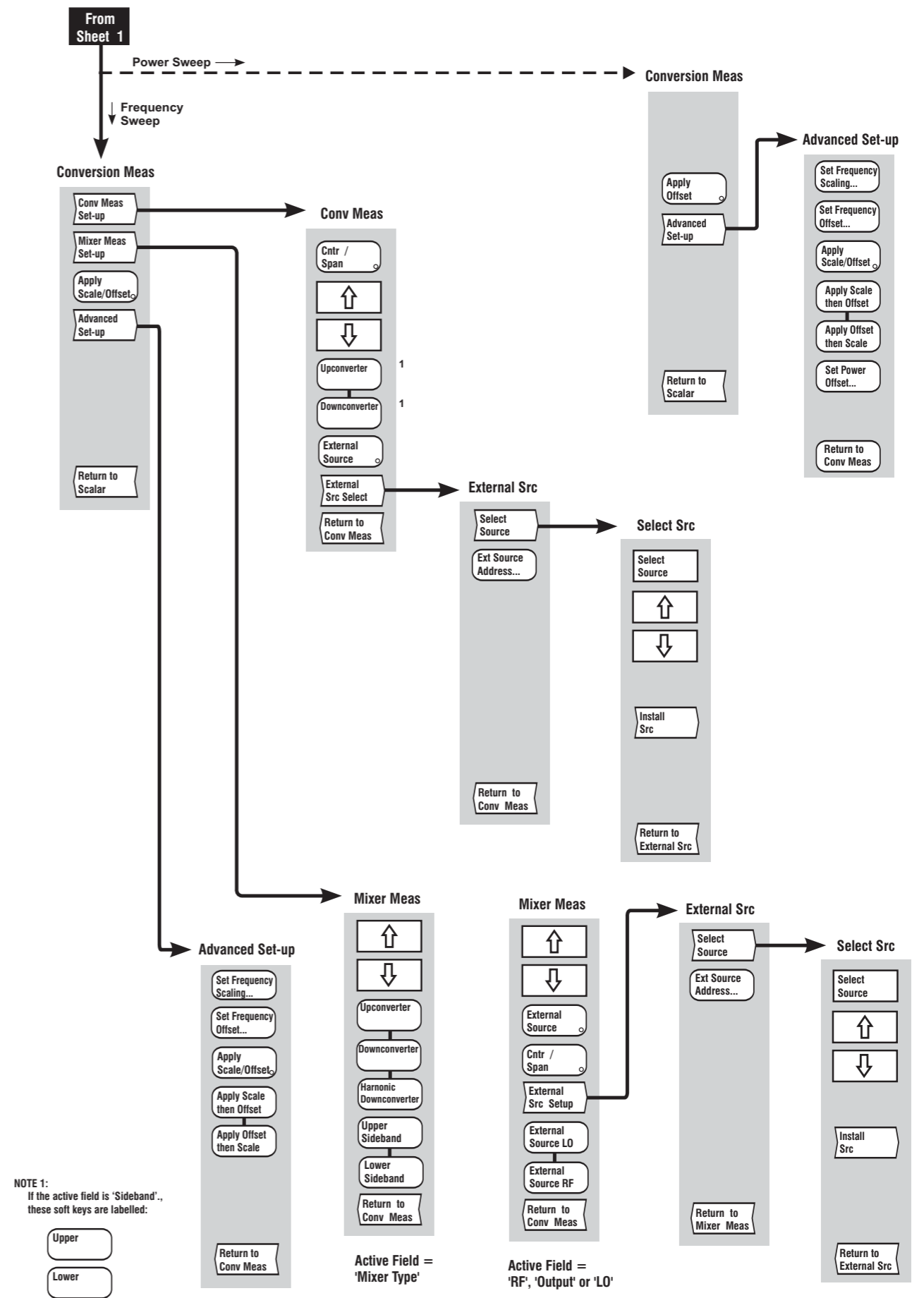

Fig. 3-15 SCALAR menus (sheet 2)

Fig. 3-15 SCALAR menus (sheet 2)

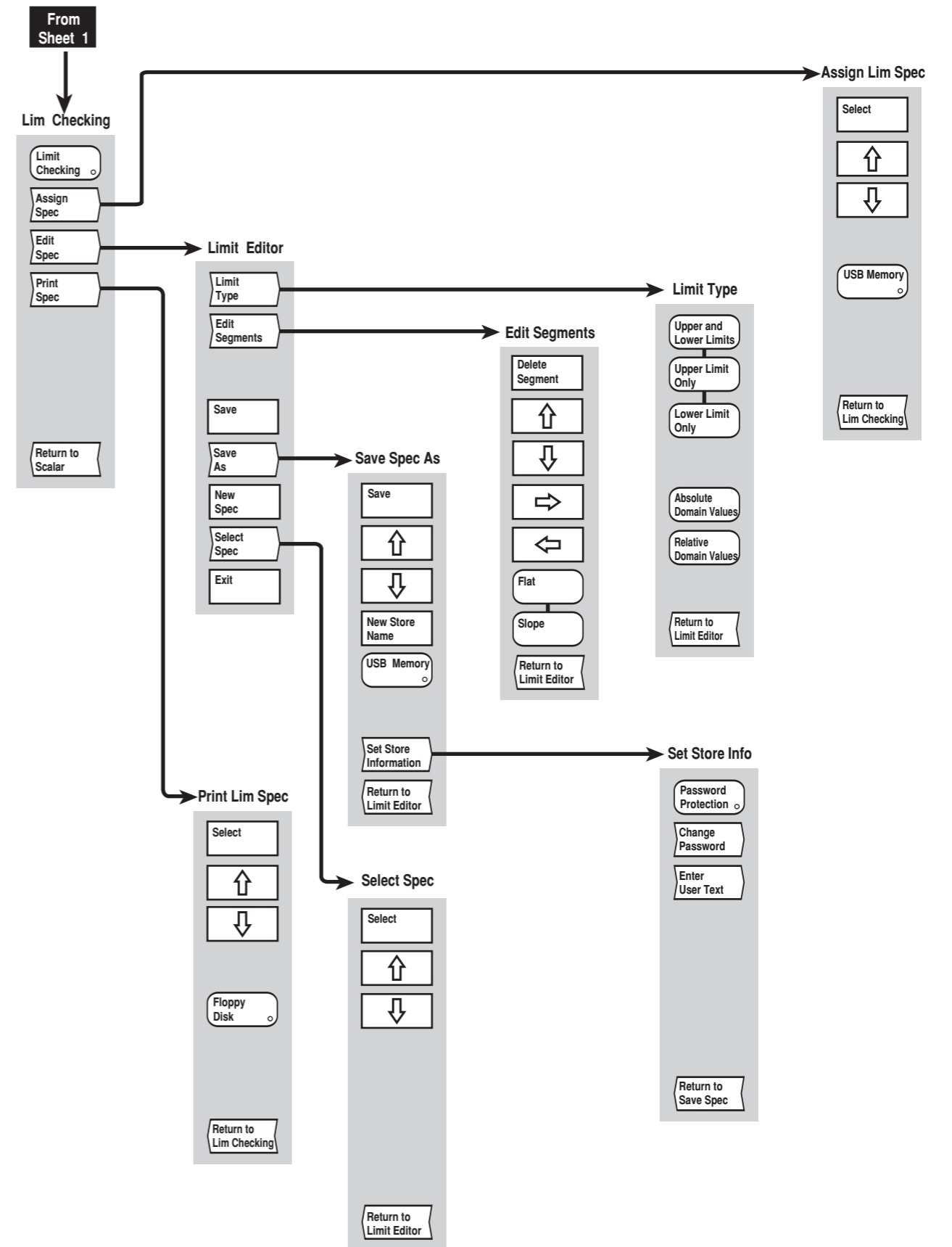

Fig. 3-16 SCALAR menus (sheet 3)

C6262

Fig. 3-16 SCALAR menus (sheet 3)

[FAULT LOCATION] key

The [FAULT LOCATION] key provides access to the menus illustrated in Figs. 3-20 to 3-22, which are used to define and set up the fault location measurement, and apply various functions to aid examination of the results.

If the active channel is not currently Fault Location, pressing this key defines it as a fault location channel containing measurement 1 (with channel specific parameters set to default values). Confirmation will be requested before the channel mode is changed and the top level menu displayed.

The current values or states for the major measurement functions of the active channel are displayed in specific locations on the screen (see 'Display' earlier in this chapter).

Values of *cutoff frequency* (for waveguide), *relative velocity* (for coax), and *attenuation* can be entered directly, for the transmission line under test. Alternatively, these parameters may be set up from a transmission line database record, or a record *store* (see the Tx Line Dbase menu, page 3-95).

FAULT LOCATION

Fault Loc See Fig. 3-20. This menu and its sub-menus are used to set up the instrument to make fault location measurements.

Configure Measurement Leads to the Config Meas menu.
See page 3-92.

This key is only selectable for a 'live' Measurement 1.

Recall Cal Conditions Recalls the measurement conditions that were present when the fault location calibration was performed.

Limit Checking Leads to the Lim Checking menu, which enables the displayed trace to be compared with user-defined limits. This is the same as for a scalar channel, except that the return soft key Returns to the Fault Location menu, not the Scalar menu.
See page 3-70.

This key is only selectable for a 'live' Measurement.

Masking Correction Toggles masking correction on or off. This feature corrects for amplitude errors caused by preceding peaks in the fault location measurement. Refer to Fig. 3-17 for an example of the effect of masking correction.

This key is only selectable for a 'live' Measurement 1.

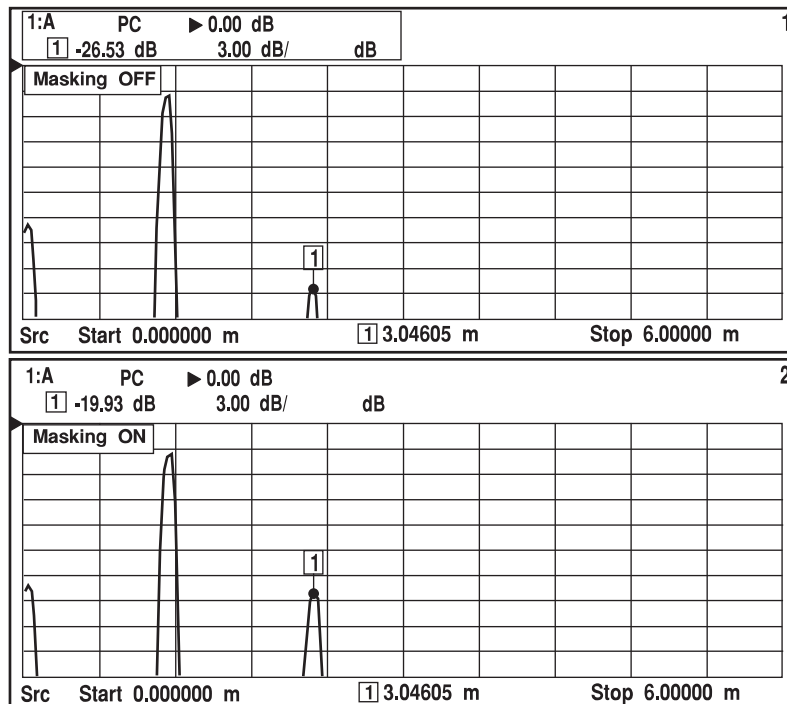

C4296

Fig. 3-17 Effect of masking correction on a fault location measurement

Averaging	Leads to the Averaging menu. <i>See page 3-100.</i> <i>This key is only selectable for a 'live' Measurement 1.</i>
Windowing	Leads to the Windowing menu. <i>See page 3-101.</i> <i>This key is only selectable for a 'live' Measurement 1.</i>
Zoom Mode	Leads to the Zoom Mode menu, which enables a part of the display range to be magnified, by changing the start and stop values. <i>See page 3-102.</i> <i>This key is only selectable for a 'live' Measurement 1.</i>
More	Leads to the second page of the Fault Location menu. <i>See page 3-91.</i>

FAULT LOCATION**More**

Fault Loc *See Fig. 3-21. This is a continuation of the previous menu.*

Database Functions Leads to the Dbase Funcs menu.
See page 3-103.

Input Set-up Leads to the Input Set-up menu, which enables the user to set up the input configuration and to compensate for detector characteristics. This is the same as for a scalar channel, except that the return soft key Returns to the Fault Location menu, not the Scalar menu.
See page 3-79.

AC Detection Selects AC detection mode for scalar measurements. With AC detection, the RF output to the DUT is chopped, and the resulting pulsed RF output from the DUT is demodulated and processed in such a way that the effects of zero drift are effectively cancelled. The AC mode therefore gives more accurate results for low signal level swept measurements.

The AC detection mode applies instrument-wide.

DC Detection Selects DC detection mode for scalar measurements. In the DC detection mode, an unmodulated RF signal is used and the detector simply converts the incident RF to an equivalent DC output. This mode will have to be used, for example, when measuring amplifiers with automatic gain control which may behave differently in the presence of amplitude modulated signals

The DC detection mode applies instrument-wide.

Return to Prior Menu Returns to the first page of the Fault Location menu.

FAULT LOCATION

Configure Measurement

Config Meas

See Fig. 3-20. This menu is used to set up the fault location measurement.

A form is displayed on the screen. The parameters shown depend upon whether or not the Transmission Line Database is being used, as shown below:

Configure Fault Location Measurement		
Entry mode :	Range	
Range :	100.000 m	Start frequency : 9.92547 GHz
Centre frequency :	10.0000 GHz	Stop frequency : 10.0745 GHz
Tx line medium :	Coax	
Relative velocity :	1.000	Cutoff frequency : -
Attenuation :	0.000 dB/m	
Display units :	Metres	
Number of points :	200	
Input configuration :	Scalar Inputs	

B4348

Database not used

Configure Fault Location Measurement		
Entry mode :	Range	
Range :	100.000 m	Start frequency : 9.92547 GHz
Centre frequency :	10.0000 GHz	Stop frequency : 10.0745 GHz
Display units :	Metres	
Number of points :	200	
Input configuration :	Scalar Inputs	
Tx line name :	Andrew LDF2-50	
Tx line medium :	Coax	
Relative velocity :	0.880	Cutoff frequency : -
Attenuation :	0.110 dB/m	

B4346

Database used

Fig. 3-18 Configuring a fault location measurement

The [↑] and [↓] soft keys are used to move between the parameters. The currently selected parameter is changed either by using the soft keys that appear on the menu, or by entering the required value as follows:

Start/stop, range/centre and cutoff frequency values

Rotary Control	✓	Step Keys	✓	=Marker	✗	Numeric Pad	✓	Terminator	10+
----------------	---	-----------	---	---------	---	-------------	---	------------	------------

Number of points, relative velocity and attenuation

Rotary Control	✓	Step Keys	✓	=Marker	✗	Numeric Pad	✓	Terminator	Any
----------------	---	-----------	---	---------	---	-------------	---	------------	------------

Notes on entry mode

If the Entry Mode is set to 'range entry', the range is entered and this determines the frequency span over which the source is swept. The system adjust the centre frequency to the centre of the span previously set. A different band of frequencies may be chosen by adjusting the centre frequency, but the value of span (and hence range) will always be preserved. In the frequency entry mode, a frequency span can be entered by adjusting the start/stop values. The range will then be calculated from the entered span. The following points should be noted when entering Range and Centre Frequency parameters:

The **range** is the length of the transmission line to be measured. If the line consists of several sections, the range should be set to the sum of the lengths of the individual sections. The distance range determines the frequency span of the measurement. The maximum range depends on cable or waveguide loss. The minimum range that can be entered depends on the frequency range available from the source, the number of measurement points and the relative velocity of the transmission medium. If the resulting frequency span results in one of the limits being exceeded, then the centre frequency is changed so that the frequencies are within limits.

The **centre frequency** should be set within the operating frequency bandwidth of the transmission line being tested. The centre frequency can only be set to a value which will not result in the source going beyond its frequency limits.

The **Input Configuration** parameter will only be selectable on 6800A versions that include a spectrum analyzer (6840A series).

The **Range** and **Centre Frequency** parameters will only be selectable if the Entry Mode is set to 'range entry'.

The **Start Frequency** and **Stop Frequency** parameters will only be selectable if the Entry Mode is set to 'frequency entry'.

The **Relative Velocity** represents the speed of propagation through the transmission medium as a fraction of the speed of light in free space range (0 to 1). If the line consists of more than one section, and the relative velocities are significantly different, an 'average' value can be calculated for the composite line. The individual figures for relative velocity should be weighted to take account of the relative lengths of the sections, i.e. the longer the section, the greater the effect it has on the composite figure. The relative velocity is 1 for most waveguides

The **Cutoff Frequency** is the frequency below which propagation ceases in the waveguide. This parameter is required in order that the 6800A can generate the non-linear frequency sweep that is required for waveguide measurements.

The **Attenuation** parameter is the attenuation characteristic of the transmission medium in dB/m or dB/ft, depending on the distance units that have been selected. If the line consists of more than one section, and the attenuation figures are significantly different, an 'average' value can be calculated for the composite line. The individual figures for attenuation should be weighted to take account of the relative lengths of the sections, i.e. the longer the section, the greater the effect it has on the composite figure.

If the transmission line database is being used the following parameters will not be selectable, since they are derived from the database :

- Tx Line Medium
- Cutoff Frequency
- Relative Velocity
- Attenuation

The Cutoff Frequency parameter will only be displayed if Tx Line Medium is set to Waveguide.

The Relative Velocity parameter will only be displayed if Tx Line Medium is set to coax.

Note If some of the parameters are changed subsequent to calibration, the calibration will

become invalid, and an error message will be displayed. To recall the measurement conditions that were present when the fault location calibration was performed, use the *[Recall Cal Conditions]* soft key in the Fault Loc menu.

Tx Dbase In Use Enables the Tx Line Medium, Waveguide Cutoff Frequency / Coax Relative Velocity, and Attenuation to be set from a Transmission Line Database record, or from a record store. The Transmission Line Database is stored internally. Record stores are copies (or copies modified by the user) of individual database records. They may held in non-volatile stores within the instrument, and also on removable storage, if required.

↑ Makes the previous parameter in the form active.

↓ Makes the next parameter in the form active.

The functions of the next two soft keys depend on which parameter has been selected. The soft keys are not present if parameters other than the ones listed below are selected

Medium parameter selected

Coax Sets the medium to coax.

Waveguide Sets the medium to waveguide

Entry Mode parameter selected

Range Sets the entry mode to 'range entry'.

Frequency Sets the entry mode to 'frequency entry'.

Display Units parameter selected

Metres Sets the distance units to metres. This applies instrument-wide.

Feet Sets the distance units to feet. This applies instrument-wide.

Input Configuration parameter selected

Scalar Input When selected, if the fault location connector of a 6240 Series Fault Locator is connected to one of the scalar inputs, the measurement definition will assume single detector fault location measurements on that input.

If a 6240 series device is not found, however, the instrument will assume that A Transmission Line Test Head (e.g. type 6581 or 6583) is being used for a ratio fault location measurement, with the fault location detector connected to input B, and the reference detector connected to input C.

Tuned Input Selects the spectrum analyzer receiver as the input.

Select Tx Line from Dbase	Leads to the Tx Line Dbase menu. <i>See page 3-95.</i> <i>This soft key will only be displayed if the Tx Line Database is in use.</i>
Select Tx Line from Store	Leads to the Tx Line Store menu. <i>See page 3-99.</i> <i>This soft key will only be displayed if the Tx Line Database is in use.</i>
Return to Fault Loc	Returns to the Fault Loc menu.

FAULT LOCATION**Configure Measurement****Select Tx Line from Dbase**

Tx Line Dbase *See Fig. 3-20. This menu enables the Tx Line Medium, Waveguide Cut-off Frequency / Coax Relative Velocity and Attenuation parameters to be set from a transmission line database record. The transmission line database is stored internally.*

Each database record consists of the following fields:

- Manufacturer
- Transmission line type number
- Medium (coax or waveguide)
- Cutoff Frequency (for waveguide)
- Relative Velocity (for coax)
- Attenuation vs. frequency table

To use the parameters from a database record, it must be selected from the database. Once selected, it is stored in the non-volatile 'Currently Selected Transmission Line store'. This is the data that is used by the instrument until a new transmission line record or store is selected, or the 'Tx Line Database in Use' parameter is turned off in the Config Meas menu.

If, at power-up, the transmission line database is being used, the parameters will be set up from the 'Currently Selected Transmission Line store'. If this store is corrupted, invalid or empty, the user entered parameters will be used.

On entering the Tx Line Dbase menu, a read only form is displayed, showing the subset selection criteria. Below this a list is displayed, showing the data for transmission lines that match the subset selection criteria specified in the Select Subset menu. The [\uparrow], [\downarrow], [*Page Up*] and [*Page Down*] soft keys are used to highlight the required transmission line record.

The data can be viewed by pressing the [*View Data*] soft key; the record is loaded from the database by pressing [*Select*]. Transmission line selection can be aborted by pressing [*Return to Config Meas*], and the 'Currently Selected Transmission Line store' will remain unchanged. Note that only the first 20 characters of the manufacturers' names will be displayed

Select	Selects the highlighted transmission line database record for use and returns to the Config Meas menu.
---------------	--

↑	Selects the previous record in the list. The list automatically scrolls, if necessary, when the highlight reaches the top of the list. <i>This soft key will be unselectable if the highlight is at the beginning of the list.</i>
↓	Selects the next record in the list. The list automatically scrolls, if necessary, when the highlight reaches the bottom of the list. <i>This soft key will be unselectable if the highlight is at the end of the list.</i>
Page Up	Displays the previous page of entries in the list. <i>This soft key will be unselectable if the first page in the list is being displayed.</i>
Page Down	Displays the next page of entries in the list. <i>This soft key will be unselectable if the last page in the list is being displayed.</i>
Select Subset	Leads to the Select Subset menu. <i>See page 3-97.</i>
View Data	Used to display all the data for the currently highlighted transmission line. <i>This soft key will be unselectable if no transmission lines are listed.</i>
Return to Config Meas	Returns to the Config Meas menu.

FAULT LOCATION

Configure
MeasurementSelect Tx Line
from DbaseSelect
Subset**Select Subset**

See Fig. 3-20. This menu allows a subset of the Transmission Line Database to be listed. It is possible to select a subset by manufacturer, medium (waveguide or coax), or by transmission line type number, or any combination of the three.

A form is displayed which lists the three subset selection criteria. One of these can be made the active criterion by using the [\uparrow] and [\downarrow] soft keys. The other soft keys provide various ways of altering the active subset selection criterion.

Search

Applies the new subset selection criteria, and returns to the Tx Line Dbase menu.

 \uparrow

Used to select the active subset selection criterion.

 \downarrow

Used to select the active subset selection criterion.

The functions of the next three soft keys depend on the subset selection criteria that has been selected.

Active subset selection criterion is Manufacturer or Transmission Line.**Any**

For a given subset selection criterion all entries will be displayed.

Text

Allows text entry for the active subset selection criterion.

The text entry form can be used to enter the manufacturer or transmission line type number. The last character may be a wildcard (*); e.g. 'Abc*' will select all names beginning with 'abc'. The case of characters is ignored when selecting.

The current manufacturer / transmission line type number from the subset selection criteria is displayed on entry to the form; 'any' is shown as '*'.

Menu

Leads to the Menu menu, which allows entry of subset selection criteria by selecting items from a menu.

See page 3-98.

Active subset selection criterion is Medium**Any**

Sets the medium to 'any'.

Coax

Sets the medium to Coax.

Waveguide

Sets the medium to Waveguide.

**Return to
Tx Line Dbase**

Returns to the Tx Line Dbase menu.

Note If a search is not performed then the subset criteria will be reset to their old values.

FAULT LOCATION

Configure Measurement

Select Tx Line from Dbase

Select Subset

Menu

Menu

See Fig. 3-20. This menu allows the manufacturer or transmission line type number (as specified in the Select Subset menu) to be selected from an alphabetically arranged list.

The [\uparrow], [\downarrow], [*Page Up*] and [*Page Down*] soft keys are used to highlight the required item, and [*Select*] is used to make the selection.

Select

Selects the highlighted entry, and returns to the Select Subset menu.

\uparrow

Selects the previous entry in the list. The list automatically scrolls, if necessary, when the highlight reaches the top of the list.

This soft key will be unselectable if the highlight is at the beginning of the list.

\downarrow

Selects the next entry in the list. The list automatically scrolls, if necessary, when the highlight reaches the bottom of the list.

This soft key will be unselectable if the highlight is at the end of the list.

Page Up

Displays the previous page of entries in the list.

This soft key will be unselectable if the first page in the list is being displayed.

Page Down

Displays the next page of entries in the list.

This soft key will be unselectable if the last page in the list is being displayed.

Return to Select Subset

Returns to the Select Subset menu.

FAULT LOCATION

Configure
MeasurementSelect Tx Line
from Store**Tx Line Store**

See Fig. 3-20. This menu provides facilities for the Tx Line Medium, Waveguide Cutoff Frequency / Coax Relative Velocity and Attenuation parameters to be set from a transmission line store.

Each Tx line store contains the following data:

- Manufacturer
- Transmission line type number
- Medium (coax or waveguide)
- Cutoff Frequency (for waveguide)
- Relative Velocity (for coax)
- Attenuation vs. frequency table

On entering the Tx Line Store menu, a list is displayed, showing the names of the stores along with the manufacturers name, Tx line type number and the medium. A section at the bottom of the form will display the descriptive text for the currently selected store in the list, along with its date and time stamp and whether or not it is password protected

To use the parameters from a store, it must be selected from the displayed list. Once selected, it is stored in the non-volatile 'Currently Selected Transmission Line Store'. This is the data that is used by the instrument until a new transmission line store or database record is selected, or 'Tx Dbase In Use' is turned off in the Config Meas menu.

If, at power-up, the transmission line database is being used, the parameters will be set up from the 'Currently Selected Transmission Line store'. If this store is corrupted, invalid or empty, the user entered parameters will be used.

The data held in the selected store can be viewed by pressing the [View Data] soft key, and is selected for use by pressing the [Select] soft key.

Select

Selects the highlighted transmission line database store for use.

↑

Selects the previous store in the list. The list automatically scrolls, if necessary, when the highlight reaches the top of the list.

This soft key will be unselectable if the highlight is at the beginning of the list

↓

Selects the next store in the list. The list automatically scrolls, if necessary, when the highlight reaches the bottom of the list.

This soft key will be unselectable if the highlight is at the end of the list

**USB
Memory**

When selected the list of stores shown will be those found in the current directory on the removable storage currently inserted in the USB port. As well as the list of stores any directories found in the current directory will also be shown. The [ENTER / =MKR] key is used to change directory.

Note Access to the removable storage is global to the instrument and the state is preserved across visits to all menus that can access the USB ports.

**View
Data**

Used to display all the data for the currently highlighted transmission line.

This soft key will be unselectable if no transmission lines are listed.

**Return to
Config Meas**

Returns to the Config Meas menu.

FAULT LOCATION

Averaging

Averaging

See Fig. 3-20. Averaging is used to reduce the amount of noise on a trace. The minimum amount of averaging should be selected, to reduce noise to an acceptable level, in order to maintain a sufficiently fast response.

Each new sweep is averaged into the trace until the sweep count is equal to the user-entered average number, for a fully averaged trace. This condition is indicated by the 'A' flag in the trace information area. The flag is in lower case until this condition is reached. It is absent if the averaging function is turned off.

The amount of averaging is set by using [*Set Average Number*]. The averaging process can be re-started by using [*Restart Averaging*].

Averaging

Toggles averaging on or off.

Set Average Number

Enables entry of the average number to be used in the averaging function. When using the rotary control, and step keys, the average number will be incremented in powers of 2.

Rotary Control	√	Step Keys	√	=Marker	×	Numeric Pad	√	Terminator	Any
----------------	---	-----------	---	---------	---	-------------	---	------------	------------

Restart Averaging

Restarts the averaging process.

Return to Fault Loc

Returns control to the Fault Loc menu.

FAULT LOCATION

Windowing

Windowing

See Fig. 3-20. Data windowing reduces the amplitudes of the sidelobes associated with the main peak on the display, but gives reduced distance resolution. Variation of the windowing level provides a trade-off between distance resolution and the height of the sidelobes.

Fig. 3-19 shows the effect on the display of low and high windowing levels.

Windowing Low

Sets the level of windowing to low. A low windowing level gives greater distance resolution but higher sidelobes.

Windowing Medium

Sets the level of windowing to medium. A medium windowing level gives an optimum trade-off between distance resolution and sidelobe height for most applications. This is the default setting for the instrument.

Windowing High

Sets the level of windowing to high. A high windowing level gives reduced sidelobe height at the expense of some distance resolution.

Return to Fault Loc

Returns to the Fault Location menu.

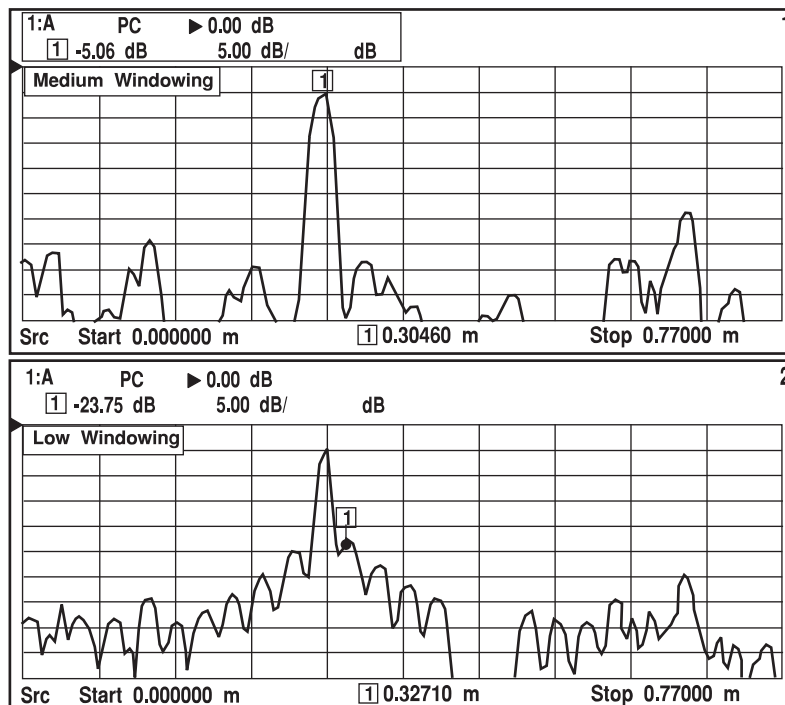

C4299

Fig. 3-19 Effect of data windowing on a fault location measurement.

FAULT LOCATION

Zoom Mode

Zoom Mode

See Fig. 3-20. Following calibration, the horizontal axis will display distance from zero to the range specified in the Config Meas menu. This menu enables the user to specify a sub-range of displayed distance by entering the required start and stop, or centre and span values. This effectively provides a magnification facility for a selected part of the range. Note that the frequency sweep of the source remains constant; the magnification is accomplished by processing the measurement results.

Zoom mode gives an optimally interpolated display trace resulting in improved distance and amplitude accuracy when displaying a sub-range of the overall distance. The measurement time is significantly increased in Zoom mode, however.

The display start and stop values can also be set to distances corresponding to the position of the active marker. This is done by pressing the appropriate soft key, positioning the active marker on the trace, and then pressing the [ENTER / =MKR] key on the numeric keypad.

If the centre & span mode has been selected, the centre value may be set by pressing [Set Display Cntr], positioning the active marker, and then pressing [ENTER / =MKR]. The span may be set by pressing [Set Display Span], positioning the active and delta markers to the appropriate points either side of the centre, and then pressing [ENTER / =MKR]. (If necessary, enable the delta marker from the Marker menu).

If the measurement range is changed, while in this mode, the display will show the new measurement range, rather than the sub-range, after re-calibration.

The first two soft keys depend on whether the Start/Stop or Centre/Span mode has been selected using the [Cntr / Span] soft key

Centre / Span disabled

Set Display Start Used to enter the start value of the displayed distance sub-range, or in centre / span mode, to enter the centre value of the sub-range.

Rotary Control	√	Step Keys	√	=Marker	√	Numeric Pad	√	Terminator	10+
----------------	---	-----------	---	---------	---	-------------	---	------------	------------

Unselectable if zoom mode is off.

Set Display Stop Used to enter the stop value of the displayed distance sub-range, or in centre / span mode, to enter the span of the sub-range.

Rotary Control	√	Step Keys	√	=Marker	√	Numeric Pad	√	Terminator	10+
----------------	---	-----------	---	---------	---	-------------	---	------------	------------

Unselectable if zoom mode is off.

Centre / Span enabled

Set Display Cntr Used to enter the start value of the displayed distance sub-range, or in centre / span mode, to enter the centre value of the sub-range.

Rotary Control	✓	Step Keys	✓	=Marker	✓	Numeric Pad	✓	Terminator	10+
----------------	---	-----------	---	---------	---	-------------	---	------------	------------

Unselectable if zoom mode is off.

Set Display Span Used to enter the stop value of the displayed distance sub-range, or in centre / span mode, to enter the span of the sub-range.

Rotary Control	✓	Step Keys	✓	=Marker	✓	Numeric Pad	✓	Terminator	10+
----------------	---	-----------	---	---------	---	-------------	---	------------	------------

Unselectable if zoom mode is off.

Cntr / Span When selected, the distance sub-range may be entered in centre / span terms, rather than start / stop.

Zoom Mode Toggles Zoom mode on or off.

Return to Fault Loc Returns to the Fault Location menu.

FAULT LOCATION

More

Database Functions

Dbase Funcs *See Fig. 3-21.*

Copy from Database Leads to the Cpy from Dbase menu, which allows a record to be copied, from the Transmission Line Database to a selected internal store.
See page 3-104.

Edit Store Leads to the Edit Store menu, which allows an internal store to be edited to create a record for a transmission line that is not in the database.
See page 3-107.

Return to Fault Loc Returns to the Fault Location menu.

FAULT LOCATION

More

**Database
Functions**

**Copy from
Database**

Cpy from Dbase

See Fig. 3-21. This menu enables a record to be selected from the **Transmission Line Database** and copied to an internal store so that it can be edited.

A form is displayed showing details of the record that is to be copied along with information about the store it will be copied to.

Copy

Copies the data for the specified transmission line to the specified store.

This soft key will be unselectable if no transmission line record or no store has been selected.

**Select
Record**

Leads to the Tx Line Dbase menu.

See page 3-105.

**Select
Store**

Leads to the Select Store menu.

See page 3-106.

**Return to
Dbase Funcs**

Returns to the Dbase Funcs menu.

FAULT LOCATION	More	Database Functions	Copy from Database	Select Record
----------------	------	--------------------	--------------------	---------------

<u>Tx Line Dbase</u>	<p>See Fig. 3-21. This menu is used to select a record for copying from the Transmission Line Database.</p> <p>A form, similar to that for the Tx Line Dbase menu (page 3-95), is displayed.</p>
Select	<p>Selects the highlighted transmission line record as the one to be copied.</p> <p><i>This soft key will be unselectable if no transmission lines are listed.</i></p>
↑	<p>Selects the previous record in the list. The list automatically scrolls, if necessary, when the highlight reaches the top of the list.</p> <p><i>This soft key will be unselectable if the highlight is at the beginning of the list.</i></p>
↓	<p>Selects the next record in the list. The list automatically scrolls, if necessary, when the highlight reaches the bottom of the list.</p> <p><i>This soft key will be unselectable if the highlight is at the end of the list.</i></p>
Page Up	<p>Displays the previous page of entries in the list.</p> <p><i>This soft key will be unselectable if the first page in the list is being displayed.</i></p>
Page Down	<p>Displays the next page of entries in the list.</p> <p><i>This soft key will be unselectable if the last page in the list is being displayed.</i></p>
View Data	<p>Used to display all the data for the currently highlighted transmission line.</p> <p><i>This soft key will be unselectable if no transmission lines are listed.</i></p>
Select Subset	<p>Leads to the Select Subset menu. This menu is the same as that for the Tx Line Dbase menu. See page 3-97.</p>
Return to Cpy Dbase	<p>Returns to the Cpy from Dbase menu.</p>

FAULT LOCATION

More

Database
FunctionsCopy from
DatabaseSelect
Store**Select Store**

See Fig. 3-21. This menu is used to select the store to which the transmission line database record will be copied to.

A list is displayed, showing the names of the stores along with the manufacturers name, transmission line type number and the medium.

As well as the store id, its associated date and time stamp are also displayed in the list. A section at the bottom of the form will display the descriptive text for the currently selected store in the list and state whether or not it is password protected.

Select

Selects the highlighted transmission line database store for use.

↑

Selects the previous store in the list. The list automatically scrolls, if necessary, when the highlight reaches the top of the list.

This soft key will be unselectable if the highlight is at the beginning of the list.

↓

Selects the next store in the list. The list automatically scrolls, if necessary, when the highlight reaches the bottom of the list.

This soft key will be unselectable if the highlight is at the end of the list.

**New Store
Name**

Enables a new store name to be entered.

**USB
Memory**

When selected the list of stores shown will be those found in the current directory on the removable storage currently inserted in the USB port. As well as the list of stores any directories found in the current directory will also be shown. The [ENTER / =MKR] key is used to change directory.

Note Access to the removable storage is global to the instrument and the state is preserved across visits to all menus that can access the USB ports.

**View
Data**

Used to display all the data for the currently highlighted transmission line store.

This soft key will be unselectable if no transmission line stores are listed.

**Set Store
Information**

Leads to the Set Store Info menu. This menu provides the same functions as the Set Store Info menu for trace memory stores.

See page 3-230.

**Return to
Cpy Dbase**

Returns to the Cpy from Dbase menu.

FAULT LOCATION

More

Database Functions

Edit Store

Edit Store

See Fig. 3-22. This function allows data to be entered for transmission lines that are not included in the Transmission Line Database. A form is displayed, which allows the data in a selected internal transmission line record store to be edited.

The form shows the following parameters :

- Manufacturer
- Transmission line type number
- Medium (coax or waveguide)
- Cutoff Frequency (for waveguide)
- Relative Velocity (for coax)
- Attenuation vs. frequency table.

The [↑] and [↓] soft keys are used to move between the parameters (with the exception of the attenuation table). The currently selected parameter is changed as follows:

Manufacturers name, Transmission line number

Use the [Edit Manufacturer] or [Edit Tx Line] soft keys to access the text entry function.

Transmission line medium

Select the medium by pressing [Coax] or [Waveguide].

Cutoff frequency

Rotary Control	X	Step Keys	X	=Marker	X	Numeric Pad	√	Terminator	10+
----------------	---	-----------	---	---------	---	-------------	---	------------	------------

The Cutoff Frequency parameter will only be selectable if the transmission line medium is waveguide.

Relative velocity

Rotary Control	X	Step Keys	X	=Marker	X	Numeric Pad	√	Terminator	Any
----------------	---	-----------	---	---------	---	-------------	---	------------	------------

The Relative Velocity parameter will only be selectable if the transmission line medium is coax.

Attenuation table

The attenuation table is edited by using the menu accessed by pressing [Edit Atten Table].

Save Store

Leads to the Save Store menu.
See page 3-108.

↑

Makes the previous parameter in the form active.

↓

Makes the next parameter in the form active.

The function of the next two soft keys depends on the parameter that has been selected.

Manufacturer's name parameter selected

Edit Manufacturer A text entry form is provided to allow editing of the manufacturer's name.

Transmission line type number parameter selected

Edit Tx Line A text entry form is provided to allow editing of the transmission line type number.

Medium parameter selected

Coax Sets the medium to coax.

Waveguide Sets the medium to waveguide

Edit Attn Table Leads to the Edit Attn Table menu.
See page 3-110.

Select Store Leads to the Select Store menu, which allows an existing store to be loaded into the editor.
See page 3-111.

Exit The editing function is terminated and control returned to the Dbase Funcs menu. If the store has been changed since it was last saved, the user will be given the opportunity to save it before the editor is terminated.



Save Store *See Fig. 3-22.* This menu is used to save the current transmission line data to a store specified by the user.

Save Saves the current data into the same store.

Save As Leads to the Tx Line Store menu, Saves the current data into a selected store or a new store.
See the following menu.

Return to Edit Store Returns to the Edit Store menu.

FAULT LOCATION

More

Database
FunctionsEdit
StoreSave
StoreSave
As**Tx Line Store**

See Fig. 3-22. This menu is used to save the current transmission line data to a store location specified by the user.

A form is displayed listing the identities of the available transmission line stores. To save the data to a specific store, the store is selected from the list. Alternatively, a new store can be created by entering a new name in the appropriate entry field.

As well as the store id, its associated date and time stamp are also displayed in the list. A section at the bottom of the form will display the descriptive text for the currently selected store in the list and state whether or not it is password protected

Save

Saves the current data into the selected store.



Selects the previous entry in the list of stores. The list automatically scrolls, if necessary, when the highlight reaches the top of the list.

This soft key will be unselectable if the highlight is at the beginning of the list.



Selects the next entry in the list of stores. The list automatically scrolls, if necessary, when the highlight reaches the bottom of the list.

This soft key will be unselectable if the highlight is at the end of the list.

**New Store
Name**

Enables a new store name to be entered.

**USB
Memory**

When selected the list of stores shown will be those found in the current directory on the removable storage currently inserted in the USB port. As well as the list of stores any directories found in the current directory will also be shown. The [ENTER / =MKR] key is used to change directory.

Note Access to the removable storage is global to the instrument and the state is preserved across visits to all menus that can access the USB ports.

**View
Data**

Used to display all the data for the currently highlighted transmission line store.

This soft key will be unselectable if no transmission line stores are listed.

**Set Store
Information**

Leads to the Set Store Info menu. This menu provides the same functions as the Set Store Info menu for trace memory stores.

See page 3-230.

**Return to
Save Store**

Returns to the Save Store menu.

FAULT LOCATION

More

**Database
 Functions**

**Edit
 Store**

**Edit
 Atten Table**

Edit Attn Table

See Fig. 3-22. This menu allows the attenuation table for the transmission line to be edited. The table specifies the attenuation values at various frequencies, and can contain up to twenty entries.

The [\uparrow], [\downarrow], [\leftarrow] and [\rightarrow] soft keys are used to highlight the entry to be edited. When an entry is highlighted the value can be edited as follows :

Frequency

Rotary Control	X	Step Keys	X	=Marker	X	Numeric Pad	√	Terminator	10+
----------------	---	-----------	---	---------	---	-------------	---	------------	------------

Attenuation

Rotary Control	X	Step Keys	X	=Marker	X	Numeric Pad	√	Terminator	Any
----------------	---	-----------	---	---------	---	-------------	---	------------	------------

**Sort
 Table**

Sorts the table into ascending frequency order.

\rightarrow

Used to select the Frequency or Attenuation field for editing.

\leftarrow

Used to select the Frequency or Attenuation field for editing.

\uparrow

Selects the previous entry in the table.

\downarrow

Selects the next entry in the table.

**Clear
 Entry**

Clears the highlighted entry in the table, after asking for confirmation.

This soft key is unselectable if the table is empty.

**Return to
 Edit Store**

Sorts the table into ascending frequency order and Returns to the Edit Store menu.

FAULT LOCATION

More

Database
FunctionsEdit
StoreSelect
Store**Select Store**

See Fig. 3-22. This menu is used to select a store to load into the editor, so that it can be modified to create a new store. A new store can also be created by entering data into a blank form.

New Store

Clears the settings for the parameters displayed on the form.

Existing Store

Leads to the Tx Line Store menu, which allows an existing store to be loaded into the editor. *See the following menu.*

Return to Edit Store

Returns to the Edit Store menu.

FAULT LOCATION

More

Database
FunctionsEdit
StoreSelect
StoreExisting
Store**Tx Line Store**

See Fig. 3-22. This menu is used to select a store to load into the editor.

A list is displayed, showing the names of the stores along with the manufacturers name, transmission line type number and the medium.

A section at the bottom of the form will display the descriptive text for the currently selected store in the list, along with its date & time stamp and whether or not it is password protected

Select

Selects the highlighted transmission line database store for editing.

↑

Selects the previous store in the list. The list automatically scrolls, if necessary, when the highlight reaches the top of the list.

This soft key will be unselectable if the highlight is at the beginning of the list.

↓

Selects the next store in the list. The list automatically scrolls, if necessary, when the highlight reaches the bottom of the list.

This soft key will be unselectable if the highlight is at the end of the list.

USB Memory

When selected the list of stores shown will be those found in the current directory on the removable storage currently inserted in the USB port. As well as the list of stores any directories found in the current directory will also be shown. The [ENTER / =MKR] key is used to change directory.

Note Access to the removable storage is global to the instrument and the state is preserved across visits to all menus that can access the USB ports.

View Data

Used to display all the data for the currently highlighted transmission line store.

This soft key will be unselectable if no transmission line stores are listed.

Return to Select Store

Returns to the Select Store menu.

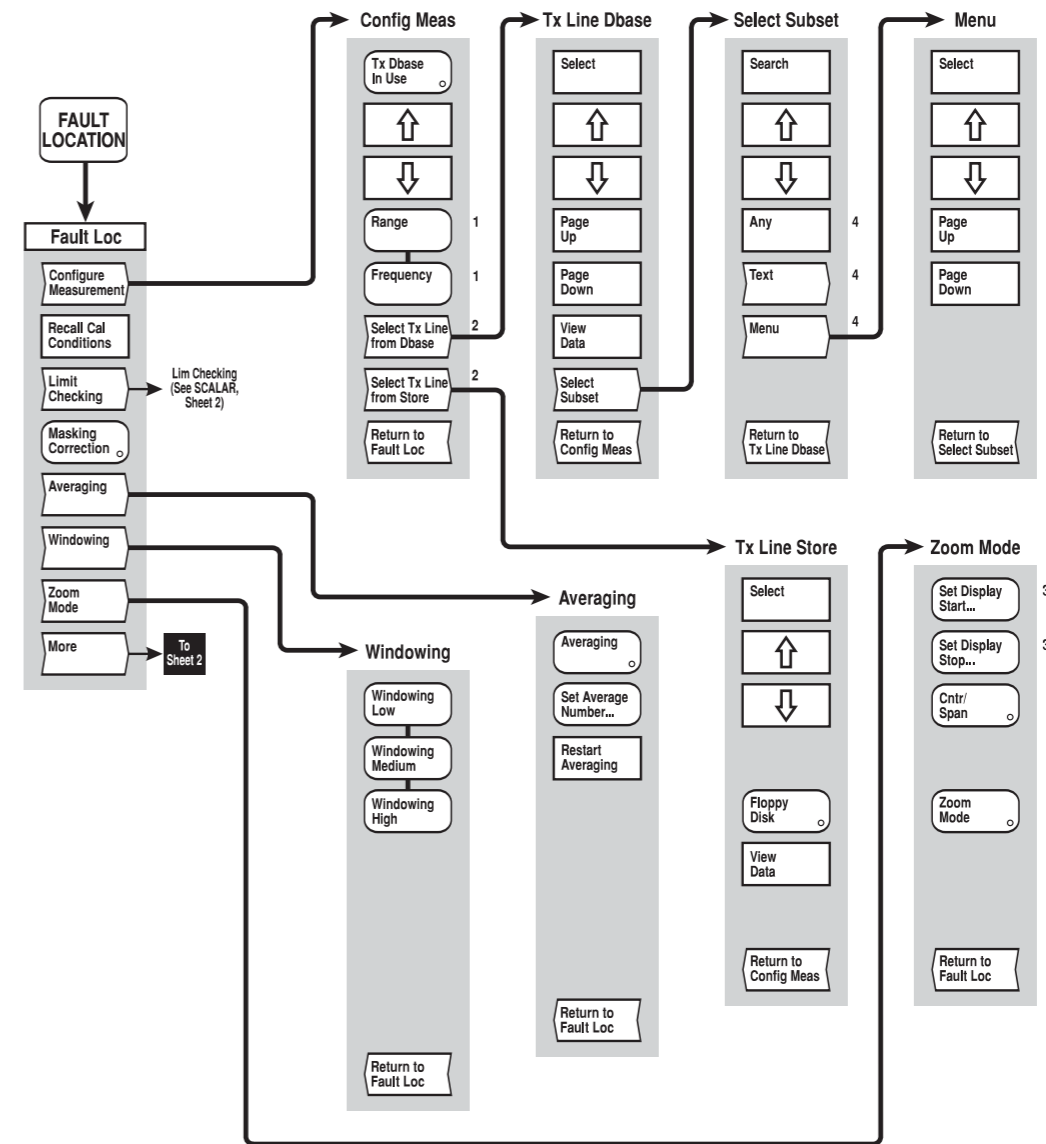

NOTE 1:

	Parameter Selected				
	Entry Mode	Display Units	Input Configuration	Medium	Other
Soft Key 4	Range	Metres	Scalar Inputs	Coax	—
Soft Key 5	Frequency	Feet	Tuned Input	Waveguide	—

NOTE 2:

These soft keys are only present when 'Tx Dbase In Use' is selected.

NOTE 3:

If Cntr/ Span is selected, these soft keys are labelled:



NOTE 4:

	Active Subset Criterion	
	Manufacturer/ Transmission Line	Medium
Soft Key 4	Any	Any
Soft Key 5	Text	Coax
Soft Key 6	Menu	Waveguide

C3647

Fig. 3-20 FAULT LOCATION menus (sheet 1)

Fig. 3-20 FAULT LOCATION menus (sheet 1)

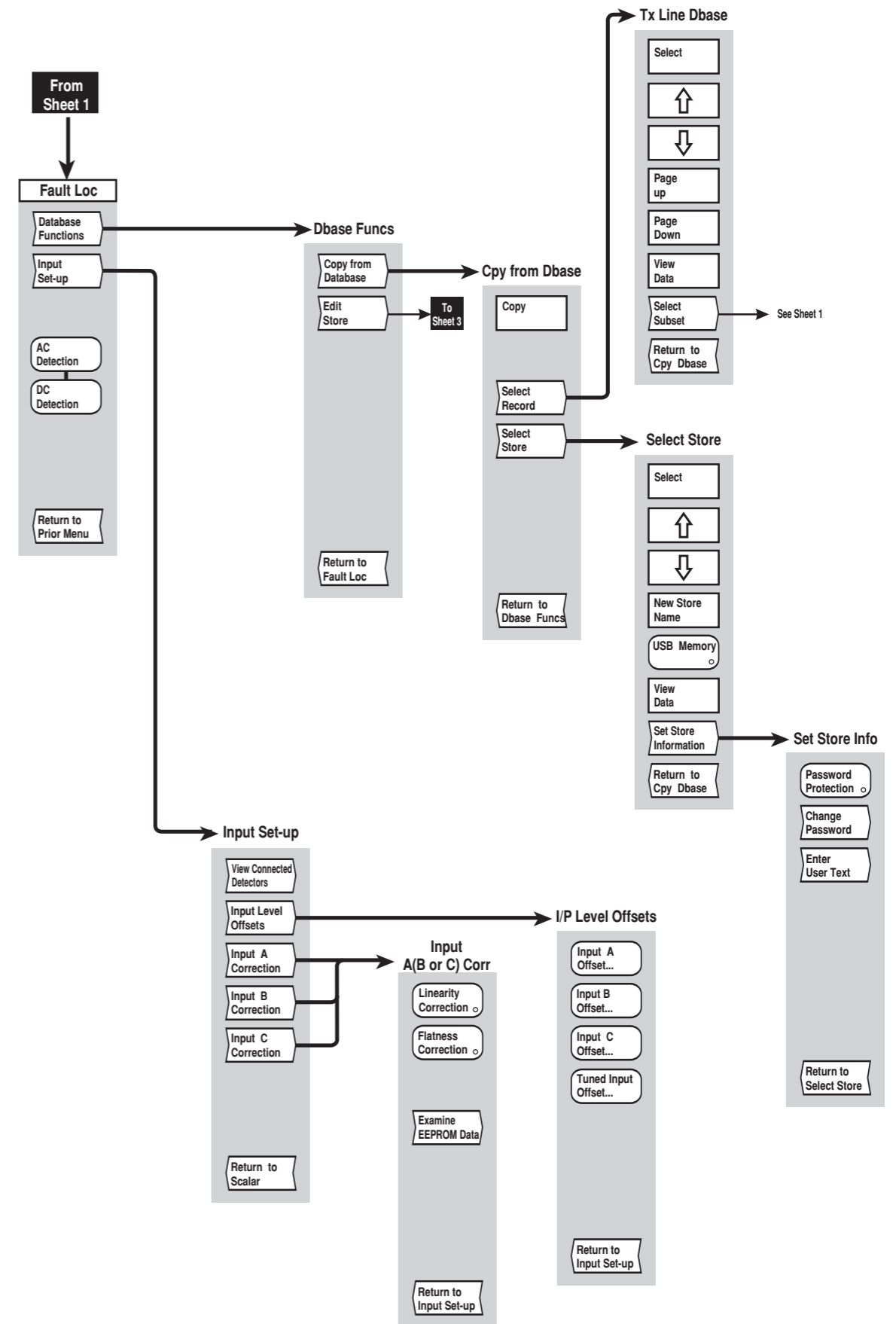

C6263

Fig. 3-21 FAULT LOCATION menus (sheet 2)

Fig. 3-21 FAULT LOCATION menus (sheet 2)

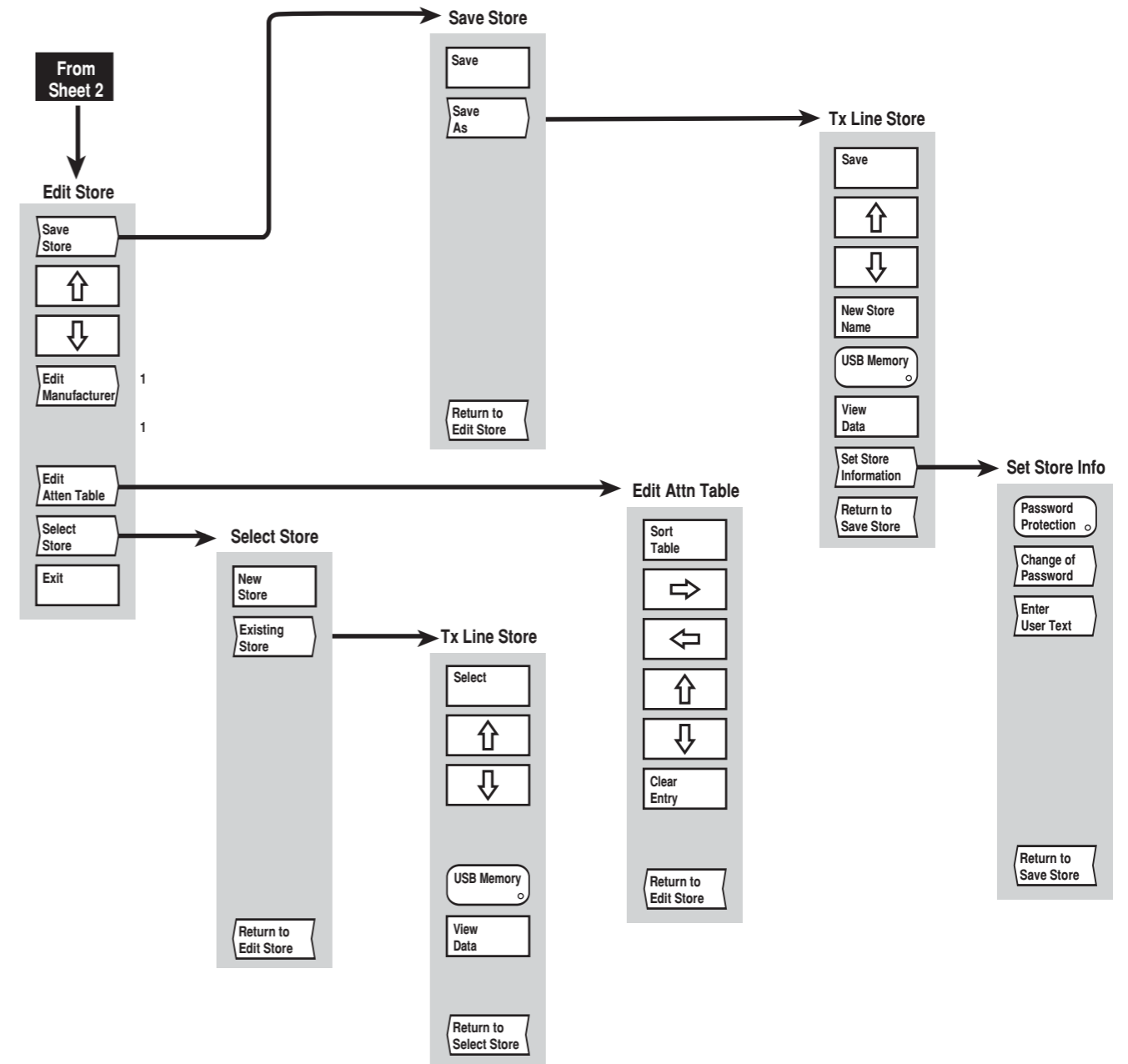

NOTE 1:

	Parameter Selected		
	Manufacturer	Transmission Line	Medium
Soft Key 4	Edit Manufacturer	Edit Tx Line	Coax
Soft Key 5	—	—	Waveguide

C6264

Fig. 3-22 FAULT LOCATION menus (sheet 3)

Fig. 3-22 FAULT LOCATION menus (sheet 3)

[SPECTRUM] key

The [SPECTRUM] key provides access to the series of menus illustrated in Fig. 3-23, and are used to define and set up the spectrum analyzer measurement and apply various functions to aid examination of the results..

If the active channel is not currently Spectrum Analyzer, pressing this key defines it as a spectrum analyzer channel containing measurement 1 (with channel specific parameters set to default values). Confirmation will be requested before the channel mode is changed and the top level menu displayed.

The current values or states for the major measurement functions of the active channel are displayed in specific locations on the screen (see 'Display' earlier in this chapter).

SPECTRUM

Spectrum

See Fig. 3-23. This menu and its sub-menus are used for setting up the instrument to make a spectrum analyzer measurement and analyzing the results.

Auto Tune

Sets up a spectrum analyzer measurement automatically:

The Resolution Bandwidth, Video Bandwidth, Input Attenuation and Sweep Time are set automatically. A wideband measurement is performed, and the receiver tuning and reference level settings are adjusted to place the peak with the highest amplitude at the reference level, and at the centre of the screen. The span is set to 20 MHz. The frequency step size is set equal to the centred signal frequency in order to facilitate stepping between harmonics.

The functions of the next two soft keys depend on the setting of the [Cntr / Span] soft key.

Centre / span disabled

Set Start Frequency

This soft key enables entry of the start frequency of the spectrum analyzer receiver.

Rotary Control	√	Step Keys	√	=Marker	√	Numeric Pad	√	Terminator	10+
----------------	---	-----------	---	---------	---	-------------	---	------------	------------

Set Stop Frequency

This soft key enables entry of the stop frequency of the spectrum analyzer receiver.

Rotary Control	√	Step Keys	√	=Marker	√	Numeric Pad	√	Terminator	10+
----------------	---	-----------	---	---------	---	-------------	---	------------	------------

Centre / span enabled

Set Cntr Frequency

This soft key enables entry of the centre frequency of the spectrum analyzer receiver.

It is often desirable to assign the active marker position to the centre frequency, so that a marked signal is centralised. This may be done by selecting [Set Cntr Frequency], followed by [ENTER / =MKR].

Rotary Control	√	Step Keys	√	=Marker	√	Numeric Pad	√	Terminator	10+
----------------	---	-----------	---	---------	---	-------------	---	------------	------------

Set Span

This soft key enables entry of the span of the spectrum analyzer receiver.

Rotary Control	√	Step Keys	√	=Marker	√	Numeric Pad	√	Terminator	10+
----------------	---	-----------	---	---------	---	-------------	---	------------	------------

Cntr / Span

When [Cntr / Span] is enabled, the spectrum analyzer receiver frequency range may be entered in centre / span form. When it is disabled, however, the frequency range may be entered in start / stop form.

**Set
Ref Level**

Sets the reference level for the active measurement (the reference level is also adjustable from the Scale / Format menu).

dBm & dB μ V formats

Rotary Control	√	Step Keys	√	=Marker	√	Numeric Pad	√	Terminator	Any
----------------	---	-----------	---	---------	---	-------------	---	------------	------------

Volts format

Rotary Control	√	Step Keys	√	=Marker	√	Numeric Pad	√	Terminator	10-
----------------	---	-----------	---	---------	---	-------------	---	------------	------------

kHz / MHz format

Rotary Control	√	Step Keys	√	=Marker	√	Numeric Pad	√	Terminator	10+
----------------	---	-----------	---	---------	---	-------------	---	------------	------------

Note The kHz / MHz format is selected automatically when an FM demodulated waveform is displayed.

**Signal
Tracking**

When enabled, this function causes the spectrum analyzer centre frequency to be adjusted, at the end of each sweep, in order to place the signal identified by the active marker at the centre of the display. This will prevent the signal going outside the sweep range, and disappearing from the screen, when narrowband sweeps are being used.

**Peak
Hold**

Leads to the Peak Hold menu.
See page 3-123.

More

Leads to the second page of the Spectrum menu.
See page 3-122.

SPECTRUM

More

Spectrum

This is a continuation of the previous menu.

Demodulation

Leads to the Demodulation menu.
See page 3-123.

**Coupled
Res BW**

Resolution bandwidth is the bandwidth of the receiver's IF filter. Resolution is the ability of the analyzer to discriminate between signals closely separated in frequency. For example, if two tones are analyzed, the analyzer will only be able to discriminate between them if the resolution bandwidth selected is narrower than the tone separation. Filter selection becomes more critical if the tones are at different levels. Narrow resolution bandwidth also results in lower noise on the trace. The resolution bandwidth can be changed in a 1,3,10...sequence between 1 kHz and 3 MHz.

Under normal circumstances, the resolution bandwidth will be set automatically by the system, following setting of the frequency range, such that it will be possible to discriminate between two signals spaced one tenth of the span apart. When this soft key is enabled, the resolution bandwidth entered by the user (using the [Set Res BW] soft key) overrides the automatic setting.

**Set
Res BW**

Allows the user to enter a value for the resolution bandwidth.

Rotary Control	√	Step Keys	√	=Marker	×	Numeric Pad	×	Terminator	×
----------------	---	-----------	---	---------	---	-------------	---	------------	---

Note The numeric pad cannot be used as the parameter is only settable in a 1, 3, 10... sequence.

**Coupled
Functions**

Leads to the Coupled Funcs menu.
See page 3-124.

**X-axis
Annotation**

Leads to the X-axis Annot menu.
See pages 3-126 and 3-127.

**External
Mixer**

Leads to the External Mixer menu.
See page 3-128.

**Limit
Checking**

Leads to the Lim Checking menu, which enables the displayed trace to be compared with user-defined limits.

The Lim Checking menu is the same as that for the Scalar channel (see page 3-70).

Limit checking will not be available when displaying a modulation waveform (see Demodulation menu, page 3-123).

**Return to
Prior Menu**

Returns to the first page of the Spectrum menu.

SPECTRUM

Peak
Hold**Peak Hold**

The Peak Hold function enables the maximum signal level at each measurement point to be retained for as long as it remains active.

**Peak
Hold**

Toggles peak hold on and off. When enabled, the instrument displays and stores a new value at each frequency of a sweep, only if it exceeds the previously stored value at that frequency.

Restart

Clears the held values, allowing the peaks to build up from zero.

Only selectable if peak hold has been selected.

**Return to
Spectrum**

Returns to the Spectrum menu.

SPECTRUM

More

Demodulation

Demodulation

This menu enables the instrument to be used in demodulation mode, where the display is the demodulated waveform plotted as FM deviation (kHz/MHz) against time.

The main use for demodulation is to help to identify the origin of a spurious transmission. Demodulated signals may be monitored on the internal loudspeaker. A front panel control turns the loudspeaker on or off, and adjusts the volume. The active marker defines the frequency of the signal to be demodulated, it will be turned on, if it is not already on, when demodulation is selected. It is possible to listen, at points of interest in the displayed spectrum, by using the marker as a 'tuning dial'.

When the spectrum analyzer receiver is sweeping, it cannot simultaneously demodulate a signal at a specific frequency. As a result, the demodulated signal will be heard as a short burst, during each measurement update. The signal can be heard continuously, however, if all of the measurements are held, using the *[Hold]* soft key in the Display menu (see page 3-52).

The modulation waveform may be viewed by enabling *[View Waveform]*. In this mode, turning on the active marker will also turn on the delta marker. The active and delta markers may then be used to obtain a rough readout of the period of the modulation waveform. The response readout will be the absolute value of the signal amplitude at the active marker, and the 'domain' readout will be the difference in time between the active and delta markers. (No other markers, or marker functions, will be available.)

The demodulation frequency may still be tuned in this mode, by first selecting *[Set Receiver Frequency]*. Any tuning that takes place, while viewing the demodulated waveform display, will be reflected in the position of the active marker on returning to the frequency domain.

Note that limit checking and peak tracking are not available when displaying a modulation waveform.

Audio

Turns the internal loudspeaker on or off.

View Waveform Allows the modulation waveform to be viewed. Its period may be roughly determined using the active and delta markers, as described above, and the demodulation frequency may be further tuned, if *[Set Receiver Frequency]* is selected. The kHz/MHz format is automatically selected when an FM modulation waveform is viewed. The centre horizontal graticule line is fixed at 0 kHz deviation.

Set Receiver Frequency If the frequency spectrum is being displayed, the rotary control will position the active marker, as usual, and hence will tune the demodulation frequency. If *[Set Receiver Frequency]* is selected, the rotary control will continue to act as before, but, in addition, a frequency can be entered as a number.

If the demodulated waveform display has been selected, the rotary control will position the active marker on the time domain waveform, by default. If *[Set Receiver Frequency]* is selected, the rotary control will then tune the demodulation frequency, and it will also be possible to enter it as a number.

The tuning range will be limited to the frequency range of the measurement

Rotary Control	√	Step Keys	√	=Marker	×	Numeric Pad	√	Terminator	10+
----------------	---	-----------	---	---------	---	-------------	---	------------	-----

Set Time / Div Allows the time/division of the demodulated waveform display to be adjusted.

Rotary Control	√	Step Keys	√	=Marker	×	Numeric Pad	√	Terminator	10-
----------------	---	-----------	---	---------	---	-------------	---	------------	-----

Only selectable if the demodulated is being viewed.

Return to Spectrum Returns to the Spectrum menu.

SPECTRUM

More

Coupled Functions

Coupled Funcs This menu is used to control the interaction of spectrum analyzer parameters.

Under normal circumstances, the video bandwidth, input attenuation and sweep time will be set automatically by the system following the setting of the frequency or reference level parameters. However, the setting of each of these parameters can be independently decoupled so that they can be set explicitly. A warning will be displayed stating that the instrument is not displaying a calibrated measurement as a result of overriding the normal couplings between parameters.

Video bandwidth. To reduce noise on the trace the detected signal is passed through a low pass filter; the high frequency cutoff frequency of the filter is known as the *video bandwidth* of the spectrum analyzer. Lower bandwidth values enable low level signals to be identified that would otherwise be buried in the noise. The video bandwidth can be set between 1 Hz and 100 kHz in a 1,3,10...sequence, with the addition of a 60 kHz setting.

Input attenuation. This is the setting of the internal RF step attenuator, which is needed to prevent high signal levels appearing at the input of the first mixer, resulting in the generation of unwanted intermodulation products. If coupling is enabled, the input attenuation will be set optimally for a signal corresponding to the reference level.

Sweep time. Due to the finite bandwidth of the resolution filters, it takes time for the energy to build up in the filter as the spectrum analyzer sweeps through a signal. If the analyzer is sweeping too fast, the resolution filters will not respond correctly; this results in the signal being reduced in amplitude and appearing to the right of the correct position. The narrower the filter, the slower the sweep speed must be.

If coupling is enabled, the sweep time for the current frequency span will be set automatically, following the setting of the resolution bandwidth (Spectrum menu), or video bandwidth. The maximum sweep speed appropriate to the resolution bandwidth will be chosen.

**Coupled
Video BW**

Turns coupling on and off for the video bandwidth. When disabled, the video bandwidth entered by the user using the soft key below overrides the automatic setting.

**Set
Video BW**

Allows the user to enter a value for the video bandwidth.

Rotary Control	√	Step Keys	√	=Marker	×	Numeric Pad	×	Terminator	Any
----------------	---	-----------	---	---------	---	-------------	---	------------	-----

Note The numeric pad cannot be used as the parameter is only settable in a 1, 3, 10... sequence (plus a 60 kHz setting).

**Coupled
Input Atten**

Turns coupling on and off for the input attenuation. When disabled, the input attenuation entered by the user using the soft key below overrides the automatic setting.

**Set
Input Atten**

Allows the user to enter a value for the input attenuation.

Rotary Control	√	Step Keys	√	=Marker	×	Numeric Pad	√	Terminator	Any
----------------	---	-----------	---	---------	---	-------------	---	------------	-----

Note The rotary control and step keys will set the attenuation in steps of 10 dB.

**Coupled
Sweep Time**

Turns coupling on and off for the sweep time. When disabled, the sweep time entered by the user using the soft key below overrides the automatic setting.

**Set
Sweep Time**

Allows the user to enter a value for the sweep time.

Rotary Control	√	Step Keys	√	=Marker	×	Numeric Pad	√	Terminator	10 ⁻
----------------	---	-----------	---	---------	---	-------------	---	------------	-----------------

**Couple All
Functions**

Used to restore coupling of the Video BW, Input Attenuation and Sweep Time parameters.

**Return to
Spectrum**

Returns to the Spectrum menu.

SPECTRUM

More

X-axis
Annotation**X-axis Annot**

(Rx or Tracking
Generator selected)

This menu allows the source of the graticule x-axis annotation to be selected.

The graticule x-axis annotation may be derived from

:

- Spectrum analyzer receiver frequency range.
- Arbitrary range entered by the user.
- Tracking Generator (source) range.

The contents of the menu varies according to which of these is selected.

None of the above selections will actually alter the frequency range measured - this will always be the receiver range, entered in the Spectrum menu. Only the numbers on the x-axis will be changed.

It is sometimes desirable to change the x-axis annotation to indicate the source range that produced the response, or, in the case of a transmission link, to show the range over which performance is being measured, when the range at the point of measurement is different.

The source of the graticule frequency annotation, i.e. Rx, User or Tracking Generator, will be indicated on the display (and hard copy).

Rx

Selects the spectrum analyzer receiver frequency range as the x-axis annotation.

User Set

Enables the user to enter a frequency range for the x-axis annotation.

See page 3-127 for the menu contents when [User Set] is selected.

**Tracking
Generator**

Selects the tracking generator frequency range as the x-axis annotation..

**Return to
Spectrum**

Returns to the Spectrum menu.

SPECTRUM

More

X-axis
Annotation

X-axis Annot
(User Set selected)

This menu allows the source of the graticule x-axis annotation to be selected.

The graticule x-axis annotation may be derived from

- :
- Spectrum analyzer receiver frequency range.
- Arbitrary range entered by the user.
- Tracking generator (source) range.

The contents of the menu varies according to which of these is selected.

None of the above selections will actually alter the frequency range measured - this will always be the receiver range, entered in the Spectrum menu. Only the numbers on the x-axis will be changed.

It is sometimes desirable to change the x-axis annotation to indicate the source range that produced the response, or, in the case of a transmission link, to show the range over which performance is being measured, when the range at the point of measurement is different.

The source of the graticule frequency annotation, i.e. Rx, User or Tracking Generator, will be indicated on the display.

Rx Selects the spectrum analyzer receiver frequency range as the x-axis annotation. This will be the actual range being displayed, if no scaling factor / offset is applied.

See page 3-126 for the menu contents when [Rx] is selected.

User Set Enables the user to enter a frequency range for the x-axis annotation.

Tracking Generator Selects the tracking generator frequency range as the x-axis annotation.

See page 3-126 for the menu contents when [Tracking Generator] is selected.

The functions of the next two soft keys depend on the setting of the [Cntr / Span] soft key.

Start / stop selected

Set Display Start This soft key enables entry of the start frequency for the x-axis annotation.

Rotary Control	√	Step Keys	√	=Marker	×	Numeric Pad	√	Terminator	10+
----------------	---	-----------	---	---------	---	-------------	---	------------	-----

Set Display Stop This soft key enables entry of the stop frequency for the x-axis annotation.

Rotary Control	√	Step Keys	√	=Marker	×	Numeric Pad	√	Terminator	10+
----------------	---	-----------	---	---------	---	-------------	---	------------	-----

Centre / span selected

Set Display Cntr This soft key enables entry of the centre frequency for the x-axis annotation.

Rotary Control	✓	Step Keys	✓	=Marker	✗	Numeric Pad	✓	Terminator	10+
----------------	---	-----------	---	---------	---	-------------	---	------------	------------

Set Display Span This soft key enables entry of the span, for the x-axis annotation.

Rotary Control	✓	Step Keys	✓	=Marker	✗	Numeric Pad	✓	Terminator	10+
----------------	---	-----------	---	---------	---	-------------	---	------------	------------

Cntr / Span When [*Cntr / Span*] is enabled, the x-axis annotation range may be entered in centre / span form. When it is disabled, however, the range may be entered in start / stop form.

Return to Spectrum Returns to the Spectrum menu.

SPECTRUM	More	External Mixer
-----------------	-------------	-----------------------

External Mixer This menu is used to set up the instrument to use an external mixer when making spectrum analyzer measurements.

External Mixer Switches the instrument between using the internal mixer and an external user supplied mixer. In the latter case, the **XXM** flag is displayed in the General Information Area.

Set Conversion Loss Allows the conversion loss of the external mixer to be set.

Rotary Control	✗	Step Keys	✗	=Marker	✗	Numeric Pad	✓	Terminator	Any
----------------	---	-----------	---	---------	---	-------------	---	------------	------------

Return to Spectrum Returns to the Spectrum Menu.

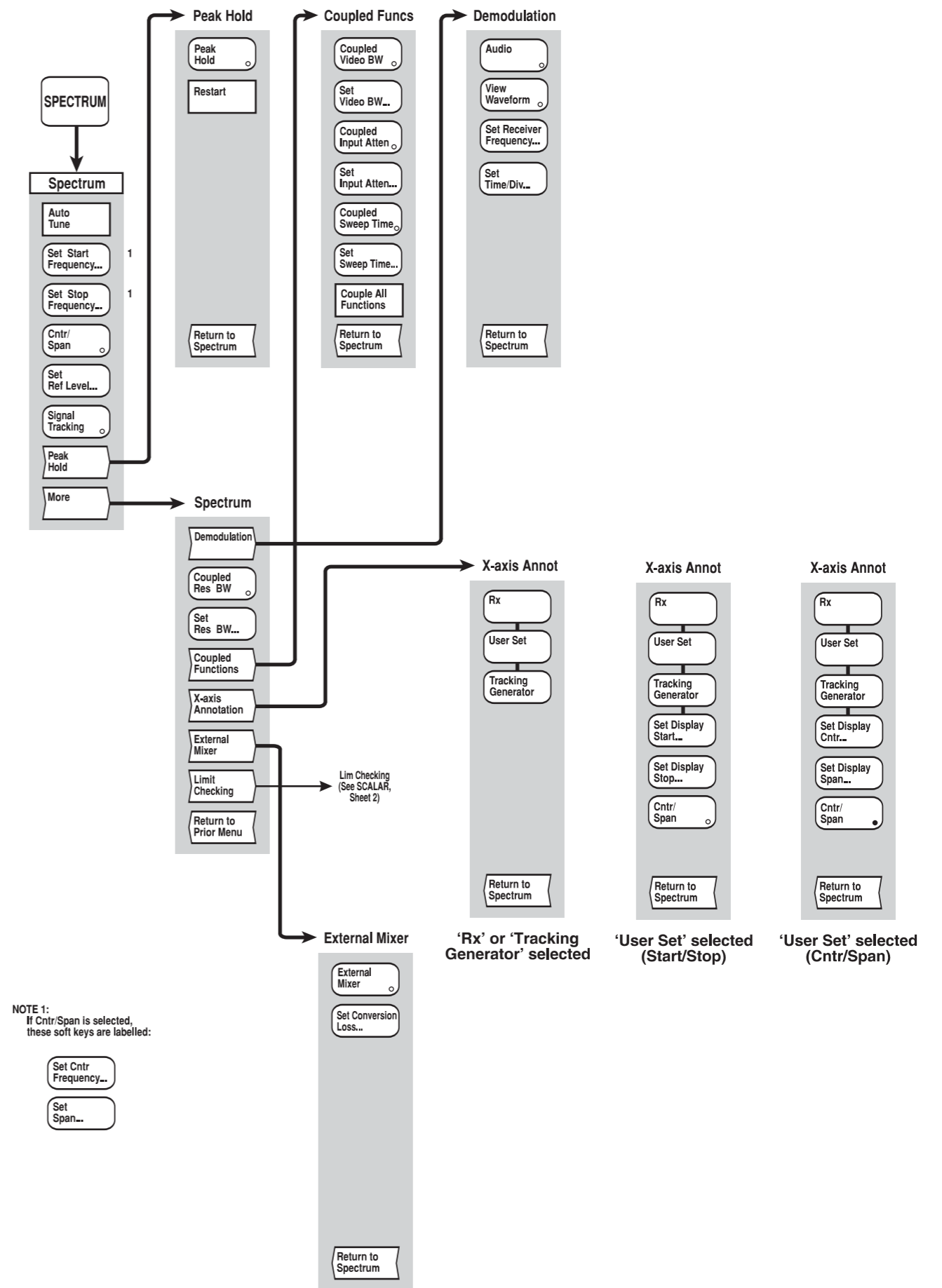

Fig. 3-23 SPECTRUM menus

Fig. 3-23 SPECTRUM menus

SETUP & ANALYSIS GROUP KEYS (Scalar Channel)

[SOURCE] key

The [SOURCE] key provides access to the series of menus illustrated in Fig. 3-25, which are used to define and control all the source functions, e.g. the synthesized sweep generator and the programmable voltage output (AUX connector). When the [SOURCE] key is pressed, the Source menu is displayed; this in turn provides access to the other soft key menus.

The [*Select Source Mode*] soft key is used to access the Source Mode menu, and the required source mode is then selected by pressing the appropriate soft key. Pressing [*Return to Source*] will return the user to the Source menu corresponding to the selected mode. There are therefore four Source menus available for a scalar channel, one for each of the source modes that can be selected from the Source Mode menu. The source modes available are:

- Start & Stop Frequency Sweep Mode (linear frequency sweep between user-defined start and stop values).
- Centre & Span Frequency Sweep Mode (linear frequency sweep defined by its centre frequency and span).
- CW Mode (continuous wave output at a user-defined frequency and power).
- Power Sweep Mode (power sweep between user-defined start and stop values).

The last three soft keys of the Source menu are the same for each source mode; the remaining five will vary to reflect the parameters required for the particular source mode.

Menus that occur more than once within the Source menu structure (e.g. Source Mode menu and Sweep Time menu) are described only once. For subsequent occurrences, a reference is made to the relevant part of the chapter.

If the source set-up is to be the same on both channels, this can be achieved using the [*Channel Coupling*] soft key in the Display menu (refer to page 3-17 for an explanation of channel coupling).

The source can be frequency modulated using an external modulating frequency present at the MOD IN/OUT connector on the rear panel. The modulating signal can also be derived internally if the Group Delay or Internal FM option is fitted.

A Source Only Mode is available in which the data acquisition system is turned off and the 6800A acts solely as a source. When in this mode, the various source settings are displayed, and all front panel keys, with the exception of the numeric keypad, units terminator keys and the [PRESET] key, will be locked out. Normal operation is restored by pressing the [*Exit Source Only Mode*] soft key on the Source menu or using the [PRESET] key.

SOURCE

Source (Start/Stop Frequency Sweep Mode) **This menu enables the source to be set up to provide a linear frequency sweep between the start frequency and stop frequency values. If channel coupling is on, the settings defined for the active channel will be duplicated on the other channel.**

The start and stop frequencies can also be set to the frequency value corresponding to the position of the active marker on the active measurement. This is done by positioning the active marker on the trace, pressing the appropriate soft key, then pressing the [ENTER / =MKR] key on the numeric keypad.

Reverse frequency sweeps are possible by making Start Frequency > Stop Frequency.

Set Start Frequency Used to change the start frequency of the source for the currently active channel to a value within the range permitted for the particular 6800A.

Rotary Control	√	Step Keys	√	=Marker	√	Numeric Pad	√	Terminator	10+
----------------	---	-----------	---	---------	---	-------------	---	------------	------------

Set Stop Frequency Similar to the above but applies to the stop frequency of the sweep.

Set Output Power Used to change the output power of the source for the active channel.

Rotary Control	√	Step Keys	√	=Marker	×	Numeric Pad	√	Terminator	Any
----------------	---	-----------	---	---------	---	-------------	---	------------	------------

Set Number of Points Used to change the number of measurement points generated by the sweep for the currently active channel, up to a maximum of 1601 points.

Rotary Control	√	Step Keys	√	=Marker	×	Numeric Pad	√	Terminator	Any
----------------	---	-----------	---	---------	---	-------------	---	------------	------------

Sweep Time Leads to the Sweep Time menu, which enables the sweep time to be set up manually or automatically.
See page 3-138.

Select Source Mode Leads to the Source Mode menu, which enables CW operation or one of several sweep modes to be selected.
See page 3-139.

Enter Source Only Mode Puts the instrument into source only mode, in which the 6800A acts solely as a source. The source parameters are displayed, as shown in Fig. 3-24. All front panel keys, with the exception of the numeric keypad, units terminator keys and the [PRESET] key are locked out. The label for this soft key changes to *[Exit Source Only Mode]*.

or

Exit Source Only Mode Returns the instrument to the measurement mode it was in before source only mode was entered. The label for this soft key is restored to *[Enter Source Only Mode]*.

More Leads to the second page of the Source menu.
See page 3-133.

SOURCE

More

<u>Source</u>	This is a continuation of the previous menu.
Levelling	Leads to the Levelling menu, which allows the levelling mode that is used to control the output power to be selected. <i>See page 3-140.</i>
Frequency Standard	Leads to the Freq Standard menu, which allows the frequency standard to be used by the synthesized source to be selected. <i>See page 3-141.</i>
Voltage Output	Leads to the Voltage O/P menu, which enables the voltage output facility to be set up. <i>See page 3-142.</i>
Loop Bandwidth	Leads to the Loop Bandwidth menu, which enables the synthesizer loop bandwidth to be varied. <i>See page 3-143.</i>
Pulse Mod	Leads to the Pulse Modulation menu, which enables internal or external pulse modulation to be set up. <i>See page 3-143.</i>
Return to Prior Menu	Returns to the first page of the Source menu.

Source Control Mode	:	Frequency Sweep
Start	:	10.000 000 MHz
Stop	:	24.000 000 000 GHz
Number of Points	:	512
Sweep Time Mode	:	Automatic
Sweep Time	:	-
Output Power	:	+0.00 dBm
Output Frequency	:	-
Levelling Mode	:	Internal
Frequency Standard Mode	:	Internal
Voltage Output Mode	:	Constant Voltage
Constant Voltage Value	:	0.00 V
Loop Bandwidth Mode	:	Automatic

B4347

Fig. 3-24 Source-only mode display

SOURCE

Source

(Centre/Span
Frequency Sweep
Mode)

This menu enables the source to be set up to provide a linear frequency sweep by defining the centre and span of the sweep. If channel coupling is on, the settings defined for the active channel will be duplicated on the other channel..

The centre and span values of the frequency sweep can also be set from the positions of the active and delta markers displayed on the active measurement. To set the centre value, position the active marker, press [*Set Cntr Frequency*], then press the [ENTER / =MKR] key on the numeric keypad. To set the span, position the delta marker at the appropriate point, either side of the centre; press the [*Set Span*] soft key, then press [ENTER / =MKR]. (If necessary, enable the delta marker from the Marker menu).

Reverse frequency sweeps are possible by entering a negative span value.

**Set Cntr
Frequency**

Used to change the centre frequency of the sweep, for the currently active channel, to a value within the range permitted for the particular 6800A.

Rotary Control	√	Step Keys	√	=Marker	√	Numeric Pad	√	Terminator	10+
----------------	---	-----------	---	---------	---	-------------	---	------------	------------

**Set
Span**

Similar to the above but applies to the span of the frequency sweep.

**Set Output
Power**

Used to change the output power of the source for the currently active channel.

Rotary Control	√	Step Keys	√	=Marker	×	Numeric Pad	√	Terminator	Any
----------------	---	-----------	---	---------	---	-------------	---	------------	------------

**Set Number
of Points**

Used to change the number of measurement points generated by the sweep for the currently active channel, up to a maximum of 1601 points.

Rotary Control	√	Step Keys	√	=Marker	×	Numeric Pad	√	Terminator	Any
----------------	---	-----------	---	---------	---	-------------	---	------------	------------

**Sweep
Time**

Leads to the Sweep Time menu, which enables the sweep time to be set up manually or automatically.

See page 3-138.

**Select Source
Mode**

Leads to the Source Mode menu, which enables CW operation or one of several sweep modes to be selected.

See page 3-139.

**Enter Source
Only Mode**

Puts the instrument into source only mode, in which the 6800A acts solely as a source. The source parameters are displayed, as shown in Fig. 3-24. All front panel keys, with the exception of the numeric keypad, units terminator keys and the [PRESET] key are locked out. The label for this soft key changes to [*Exit Source Only Mode*].

or

**Exit Source
Only Mode**

Returns the instrument to the measurement mode it was in before source only mode was entered. The label for this soft key is restored to [*Enter Source Only Mode*].

More

Leads to the second page of the Source menu.

See page 3-133.

SOURCE

Source
(CW Mode)

This menu enables the source to be set up to provide a continuous wave (CW) frequency. If channel coupling is on, the settings defined for the active channel will be duplicated on the other channel. The source can also be frequency modulated.

Set Frequency

Used to change the CW frequency of the source for the currently active channel to a value within the range permitted for the particular 6800A.

Rotary Control	√	Step Keys	√	=Marker	×	Numeric Pad	√	Terminator	10+
----------------	---	-----------	---	---------	---	-------------	---	------------	-----

Set Output Power

Used to change the output power of the source for the currently active channel.

Rotary Control	√	Step Keys	√	=Marker	×	Numeric Pad	√	Terminator	Any
----------------	---	-----------	---	---------	---	-------------	---	------------	-----

FM

Leads to the FM menu, which enables source frequency modulation to be set up.
See page 3-136.

Select Source Mode

Leads to the Source Mode menu, which enables CW operation or one of several sweep modes to be selected.
See page 3-139.

Enter Source Only Mode

Puts the instrument into source only mode, in which the 6800A acts solely as a source. The source parameters are displayed, as shown in Fig. 3-24. All front panel keys, with the exception of the numeric keypad, units terminator keys and the [PRESET] key are locked out. The label for this soft key changes to *[Exit Source Only Mode]*.

or

Exit Source Only Mode

Returns the instrument to the measurement mode it was in before source only mode was entered. The label for this soft key is restored to *[Enter Source Only Mode]*.

More

Leads to the second page of the Source menu.
See page 3-133.

SOURCE

FM

FM

This menu is used for setting up frequency modulation of the source.

External modulation is available on all instruments. Instruments with either the Group Delay or Internal FM option fitted can also use an internal modulating source.

Note that FM is only available when the instrument is in CW mode.

FM

Toggles frequency modulation of the source on or off.

External AC

Selects the signal present at the MOD IN/OUT connector as the source of the frequency modulation.

External DC

Selects the signal present at the MOD IN/OUT connector as the source of the frequency modulation. The DC level at this input is used to vary the frequency of the source. The *[DC Null]* soft key (below) should be used to compensate for any offsets within the instrument.

Internal

Selects the instrument's internal FM generator as the source of the frequency modulation

This soft key will only be present if the Group Delay or Internal FM option is fitted.

**Set
FM Deviation**

Allows the user to enter a value for the deviation of the frequency modulated source.

Rotary Control	✗	Step Keys	✗	=Marker	✗	Numeric Pad	✓	Terminator	10+
----------------	---	-----------	---	---------	---	-------------	---	------------	------------

**Set Internal
Mod Freq**

Allows the user to enter a value for the instrument's internal modulating frequency.

Rotary Control	✓	Step Keys	✓	=Marker	✗	Numeric Pad	✓	Terminator	10+
----------------	---	-----------	---	---------	---	-------------	---	------------	------------

This soft key will only be present if the Group Delay or Internal FM option is fitted, and is only selectable if Internal is selected.

DC Null

Compensates for any offsets within the instrument so that a 0 V DC level at the MOD IN/OUT connector gives zero frequency modulation

This soft key is only selectable if External DC is selected.

**Return to
Source**

Returns to the Source menu.

SOURCE

Source

(Power Sweep)

This menu enables the source to be set up to provide a linear power sweep between the start power and stop power values. If channel coupling is on, the settings defined for the active channel will be duplicated on the other channel.

Reverse power sweeps are possible by making Start Power > Stop Power.

Set Start Power

Used to change the start power level of the source for the currently active channel.

Rotary Control	✓	Step Keys	✓	=Marker	✓	Numeric Pad	✓	Terminator	Any
----------------	---	-----------	---	---------	---	-------------	---	------------	-----

Set Stop Power

Used to change the stop power level of the source for the currently active channel.

Rotary Control	✓	Step Keys	✓	=Marker	✓	Numeric Pad	✓	Terminator	Any
----------------	---	-----------	---	---------	---	-------------	---	------------	-----

Set Frequency

Used to change the CW frequency of the source for the currently active channel to a value within the range permitted for the particular 6800A.

Rotary Control	✓	Step Keys	✓	=Marker	✗	Numeric Pad	✓	Terminator	10+
----------------	---	-----------	---	---------	---	-------------	---	------------	-----

Set Number of Points

Used to change the number of measurement points generated by the sweep for the currently active channel, up to a maximum of 1601 points.

Rotary Control	✓	Step Keys	✓	=Marker	✗	Numeric Pad	✓	Terminator	Any
----------------	---	-----------	---	---------	---	-------------	---	------------	-----

Sweep Time

Leads to the Sweep Time menu, which enables the sweep time to be set up manually or automatically.

See page 3-138.

Select Source Mode

Leads to the Source Mode menu, which enables CW operation or one of several sweep modes to be selected.

See page 3-139.

Enter Source Only Mode

Puts the instrument into source only mode, in which the 6800A acts solely as a source. The source parameters are displayed, as shown in Fig. 3-24. All front panel keys, with the exception of the numeric keypad, units terminator keys and the [PRESET] key are locked out. The label for this soft key changes to *[Exit Source Only Mode]*.

or

Exit Source Only Mode

Returns the instrument to the measurement mode it was in before source only mode was entered. The label for this soft key is restored to *[Enter Source Only Mode]*.

More

Leads to the second page of the Source menu.

See page 3-133..

SOURCE

**Sweep
Time**

Sweep Time

The sweep time is the time taken for the source to complete one sweep, excluding retrace time and the time required for internal processing of the data. The setting determined by this menu will apply instrument-wide, i.e. to all displayed traces.

Longer sweep times may be necessary when testing certain devices, and also have the effect of reducing noise.

**Automatic
Sweep Time**

Sets the sweep time mode of the source to automatic. In this mode, the sweep time automatically adjusts to the minimum sweep time available for the set frequency span and number of measurement points.

**User Set
Sweep Time**

Sets the sweep time mode to manual; the following soft key can then be pressed to allow the sweep time to be changed by the operator.

**Set
Sweep Time**

Allows the sweep time to be entered. The 6800A will generate an actual sweep time that will never be faster than the sweep time entered, but may be slower, depending on constraints imposed by the number of measurement points, source frequency range and measurement definition.

Rotary Control	√	Step Keys	√	=Marker	×	Numeric Pad	√	Terminator	10
----------------	---	-----------	---	---------	---	-------------	---	------------	----

This key will only be selectable if manual sweep time mode has been selected

**Return to
Source**

Returns to the Source menu.

SOURCE

Select
Source Mode**Source Mode**

This menu enables the 6800A source to be set up to provide either a CW (continuous wave) output, or a swept output.

For swept measurements, the variable that is swept (domain) is plotted on the x-axis of the channel graticule. The frequency and power domains are supported. If two traces are displayed on the same channel, or if the two channels are coupled, they will share the same x-axis annotation. Only one of the following options can be selected at a time; pressing one of the soft keys automatically de-selects the current mode and selects the new one. The parameters of the source for the selected mode can be set up after returning to the Source menu.

**Start & Stop
Freq Sweep**

Sets the source to the swept frequency mode of operation, in which the start and stop values of the frequency sweep, and its power level, can be defined by returning to the Source menu.

**Cntr & Span
Freq Sweep**

Similar to the above, but the sweep is defined by the centre frequency and its span.

CW

Sets the source to the CW mode of operation, in which the frequency and power level can be defined by returning to the Source menu.

The CW mode assumes that the source is to be used as part of an integrated measurement system (the 6800A) where the source and data acquisition system are synchronised.

**Power
Sweep**

Sets the source to the power sweep mode of operation, in which the start and stop values of the power sweep, and its frequency, can be defined by returning to the Source menu.

**Return to
Source**

Returns to the Source menu.

SOURCE

More

Levelling

Levelling

This menu is used to select the levelling mode that is used to control the output power of the 6800A.

Levelling is used for power level control, via a fast, closed-loop feedback system. The control (feedback) signal used to level the output can be derived from either the internal levelling detector of the 6800A, or from an external detector or power meter, connected to the rear panel EXT LEVEL INPUT.

Internal levelling provides a constant signal at the SIGNAL SOURCE OUTPUT connector regardless of reflections by adjusting the level of the source, thus improving the source match. A further improvement in source match can be gained by using the external levelling mode, so that levelling is done, at a point in the system, closer to the test port. The emergent signal, at the levelled point in the system, is constant, regardless of the signal travelling back towards the source; in this way the source appears matched.

Int Levelling

Sets the levelling mode of the source to internal.

**Ext Levelling
+ve Det**

Sets the levelling mode of the source to external, and requires a detector of positive polarity.

**Ext Levelling
-ve Det**

Sets the levelling mode of the source to external, and requires a detector of negative polarity.

**Ext Levelling
Power Meter**

Sets the levelling mode of the source to external, and requires a power meter levelling output of positive polarity.

**Return to
Source**

Returns to the Source menu.

SOURCE

More

Frequency
Standard**Freq Standard**

This menu is used to select the frequency standard to be used by the synthesized source of the 6800A.

Under normal circumstances the internal crystal oscillator of the 6800A would be used, but if necessary, an external frequency standard of higher accuracy and stability can be connected to the FREQ STANDARD rear connector.

Int Std

Selects the internal crystal oscillator of the 6800A as the frequency standard. In this mode, the 6800A provides a 10 MHz reference output at the FREQ STANDARD connector, derived from an internal oscillator.

**Ext Std
1 MHz**

Enables a 1 MHz external frequency to be used as the frequency standard.

**Ext Std
10 MHz**

Enables a 10 MHz external frequency to be used as the frequency standard.

**Return to
Source**

Returns to the Source menu.

SOURCE

More

Voltage Output

Voltage O/P

The **VOLTAGE OUTPUT**, available on pin 1 of the rear panel AUX connector, can be programmed to provide a **0-10 V ramp voltage**, for swept frequency or power measurements, an **adjustable constant bias voltage output**, or a **live y-axis output**.

0 - 10 V Ramp

Sets the voltage output to provide a 0-10 V ramp voltage proportional to swept frequency or power. The output will be set to 0 V for CW mode.

Constant Voltage

Sets the voltage output to provide a constant voltage, in the range 0 - 10 V, as set by the [*Set Voltage*] soft key. This mode applies per channel, subject to the channels being uncoupled.

Live Y-Axis

The voltage output is set to a value proportional to the active marker readout on the active measurement. The scaling of the output voltage depends on the display format, as set up using the Scale / Format menu ([SCALE / FORMAT] key).

For Log format (dB/dBm), the live Y voltage output scaling is 0.25 V/decade, i.e.

$$0 \text{ V} \quad 0 \text{ dBm}, -1 \text{ V} \quad -40 \text{ dBm.}$$

giving a range of -200 dB to +200 dB/

For Linear format (Watts), output voltage = $5 \times \text{Watts}$. giving a range of 2 W.

For Volts, output voltage = $\text{volts} / 2 + 5$, giving a range of -10 V to +10 V.

For VSWR, output voltage = VSWR.

Live Y-axis output is disabled when the active measurement is a demodulated waveform

This soft key is unselectable in Source Only Mode.

Set Voltage

This soft key is used to change the value of constant voltage of the voltage output. The value specified applies per channel.

Rotary Control	√	Step Keys	√	=Marker	×	Numeric Pad	√	Terminator	10
----------------	---	-----------	---	---------	---	-------------	---	------------	----

This soft key will only be selectable for constant voltage mode.

Return to Source

Returns to the Source menu.

SOURCE

More

Loop
Bandwidth**Loop Bandwidth**

The loop bandwidth is the bandwidth of the frequency synthesizer phase-locked loop. This is determined by a filter in both the RF and microwave sections of the source. Low bandwidth reduces the spurious signal content of the source output but slows down the response; high bandwidth has the opposite effect. Independent loop bandwidth controls are provided for the RF and microwave frequency bands.

Auto

Toggles the loop bandwidth control between Automatic and Manual. When set to manual, the settings for the RF and microwave loop bandwidths are independently settable to Fast or Slow. In Auto mode, the loop bandwidth settings depend on the source mode in accordance with the table below:

RF setting	Microwave setting	Usage
Fast	Fast	AUTO setting for swept frequency modes
Fast	Slow	Low noise sweeps / medium speed hopping
Slow	Fast	not used
Slow	Slow	Auto setting for best phase noise in CW and power sweep modes

**RF
Fast**

The RF loop bandwidth is always FAST irrespective of the operating mode.

**RF
Slow**

The RF loop bandwidth is always SLOW irrespective of the operating mode.

**Microwave
Fast**

The microwave loop bandwidth is always FAST irrespective of the operating mode.

**Microwave
Slow**

The microwave loop bandwidth is always SLOW irrespective of the operating mode.

**Return to
Source**

Returns to the Source menu.

SOURCE

More

Pulse Mod

<u>Pulse Mod</u>	This menu is used for setting up pulse modulation of the source.
Pulse Mod	Enables pulse generator and modulator.
Pulse CW	Turns RF on continuously, for normalizing external equipment.
Internal	Selects internal pulse modulation (if Option 23 is fitted).
External	Selects external pulse modulation.
Set Up Pulse	Leads to the Single Pulse menu, which lets you set up pulse parameters. <i>See page 3-145.</i>
Trigger Mode	Leads to the Trigger Mode menu, which lets you define the trigger source. <i>See page 3-148.</i>
Set Delay...	Sets the delay between the trigger (internal or positive-going TTL external) and the leading edge of the modulating pulse.
Return to Source	Returns to the Source menu.

SOURCE**More****Single Pulse**

<u>Single Pulse</u>	This menu lets you set up the modulating pulse's parameters. It is displayed when the Single Pulse soft key is pressed.
Single Pulse	This menu is displayed when this soft key is pressed.
Pulse Pattern	The menu on page 3-146 is displayed when this soft key is pressed.
Set Pulse Width...	Lets you enter the width of the modulating pulse.
Set PRI...	Lets you enter the repetition interval between modulating pulses.
Set PRF...	Lets you enter the pulse repetition frequency.
Set Delay...	Sets the delay between the trigger (internal or positive-going TTL external) and the leading edge of the modulating pulse.
Return to Pulse Mod	Exits this menu and returns to the Pulse Mod menu.

SOURCE

More

Pulse Mod

Single Pulse

- Single Pulse** This menu lets you set up the modulating pulse's parameters. It is displayed when the Pulse Pattern soft key is pressed.
- Single Pulse** The menu on page 3-145 is displayed when this soft key is pressed.
- Pulse Pattern** This menu is displayed when this soft key is pressed.
- Edit Pulse Pattern** Leads to the Edit Pattern menu, which lets you set up any pattern of pulses up to 7.2 s in length.
See page 3-147.
- Set Delay...** Sets the delay between the trigger (internal or positive-going TTL external) and the leading edge of the modulating pulse.
- Return to Pulse Mod** Exits this menu and returns to the Pulse Mod menu.

SOURCE**More****Pulse Mod****Single Pulse****Edit Pattern**

Moves up the modulating pulses in the pattern list.



Moves down the modulating pulses in the pattern list.

Previous Page Goes to the previous page of modulating pulses in the list.

Next Page Goes to the next page of modulating pulses in the list.

Delete Pulse Deletes the highlighted pulse.

Insert Pulse Above Inserts a copy of the highlighted modulating pulse immediately above it.

Clear Pattern Clears all the entries in the pattern list.

Save and Exit Saves the pulse pattern, exits this menu, and returns to the Single Pulse menu.

SOURCE

More

Pulse Mod

Trigger Mode

Trigger Mode

This menu lets you set up the source for the pulse modulator trigger.

External

An external trigger (positive-going TTL) is applied to the rear-panel AUX socket.

**internal
Continuous**

(Option 23 only). Trigger pulses are generated internally to drive the pulse modulator. Timing parameters of the trigger pulses are set up in the Single Pulse menu or in the Edit Pattern menu.

**Return to
Pulse Mod**

Exits this menu and returns to the Pulse Mod menu.

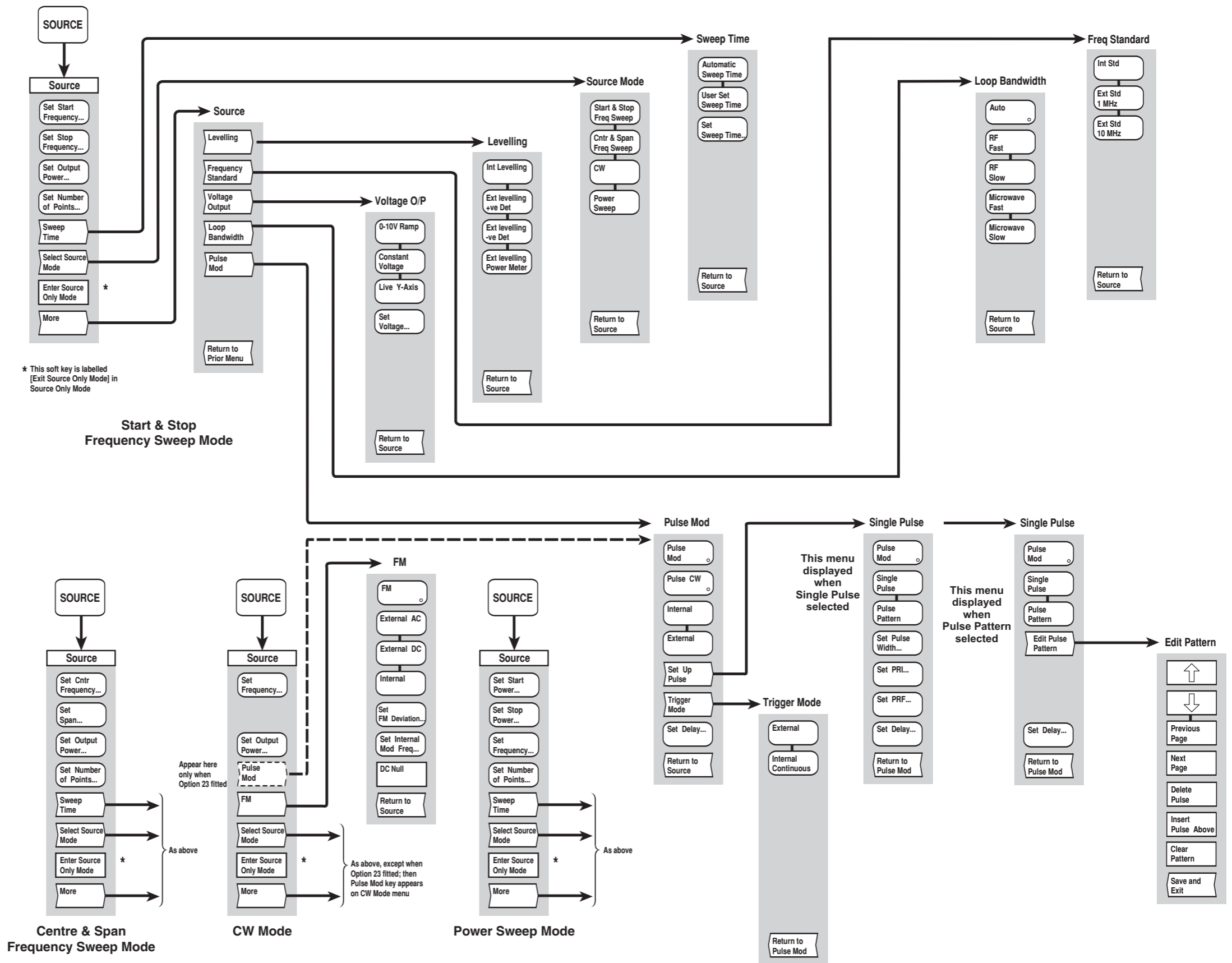

Fig. 3-25 SOURCE menus - scalar channel

Fig. 3-25 SOURCE menus - scalar channel

[CAL] key

The [CAL] key provides access to the calibration menus shown in Fig. 3-26. Calibration is used prior to a measurement in order to remove system errors that cause uncertainty in measuring a device under test.

Frequency variations in the components that comprise the measurement system (connectors, adapters, cables etc.) can be taken into account when making a component measurement. The 6800A analyzes and stores the variations and automatically removes them from the measurement. This is known as path calibration since it calibrates out the frequency variations in each measurement path.

One of four stored path calibrations can be applied to the current measurement. This results in the current measurement data being ratioed with the path calibration data, before being formatted and displayed. The trace information area of the display indicates **PC** if path calibration is being applied to a trace. By default, each measurement is associated with a particular path calibration store. However, it is possible for a measurement to use one of the other path calibration stores, so that a single path cal can be shared by more than one measurement.

If the calibration becomes invalid (e.g. due to subsequent changes in the source set-up) a warning message will be displayed, together with a '?' after the path calibration indication.

Path calibration facilities are not available when making frequency measurements under swept conditions.

CAL

- Cal** This menu provides facilities for calibrating the measurement system for a scalar channel, and applying any of the stored path calibrations to a measurement. It also provides a detector zeroing function.
- Through Cal** Leads to the Through menu, which is used to carry out a path calibration for insertion loss or group delay measurements on the currently active measurement.
See page 3-153.
- Short AND Open Cal** Leads to the Short & Open menu, which is used to carry out a short / open path calibration on the currently active measurement.
See page 3-155.

This soft key is unselectable for group delay measurements.
- Short OR Open Cal** Leads to the Short OR Open menu, which is used to carry out a path calibration on the currently active measurement by using a short circuit or open termination.
See page 3-155.

This soft key is unselectable for group delay measurements.
- Single Ended Ins Loss** Leads to the S/E Ins Loss menu.
See page 3-156.

This soft key is unselectable for group delay measurements.
- Apply Path Cal** Leads to the Apply Path Cal menu, which enables one of the path calibrations to be selected, and applied to the currently active measurement. The relevant trace information area will indicate if path calibration is being applied, and which path cal store is being used.
See page 3-157.
- Path Cal Off** Turns path calibration off for the currently active measurement.
- Detector Autozeroing** Zeroing is used to remove the effects of zero drift from the measurement. It is especially important for low level measurements (< -40 dBm). At very low levels (< -60 dBm), zeroing should be performed every few minutes, but preferably the autozeroing facility should be used.

The [*Detector Autozeroing*] soft key toggles autozeroing on and off. When it is turned on, the detectors will be zeroed automatically, once every measurement update. The 6800A momentarily turns off the RF in order to do this. The setting of this parameter applies instrument-wide, and the **AZ** indicator is displayed in the General Information Area when autozeroing is on.

The autozeroing facility only operates if a manual zero has previously been performed (see [*Zero Detectors*] below).
- Zero Detectors** Initiates manual zeroing of the detectors. A zero will be performed on all inputs, including any that do not have a detector connected. If a detector is then connected to one of the previously unused inputs, the zero is no longer valid, and misleading results could occur. It is therefore necessary to perform a detector zero each time a detector is connected to an input.

The source power will be automatically turned off during a detector zero. If a source other than the 6800A is providing the RF signal, it must be turned off before performing a zero.

CAL

Through Cal

Through

This function is used to carry out a through path calibration on the currently active measurement. It compensates for residual levelling errors in the source, and frequency variations in the components that form the measuring system. It is also used to normalise group delay measurements.

The user is prompted to make the through connection. The *[Select Path Cal Store]* soft key is used to specify the path calibration store that is to be used for storing the calibration data. The *[Continue]* soft key starts the calibration process. The user is informed when calibration data has been acquired, and path calibration has been applied. The function then terminates, and the user is returned to the Cal menu.

Calibration for group delay measurements is similar to that of a conventional ‘through’ path calibration for insertion loss, except that delay time (rather than amplitude) is stored. This normalises the measurement to remove any delays in the measurement system.

Three options are available when performing a through calibration for a measurement on a frequency conversion device (either conversion gain or group delay).

The first is to re-tune the receiver to the source frequency range during calibration; this option is selected using the *[Source Freq Range]* soft key. This is the default and is the option that would normally be used.

The second method is to perform the calibration with the spectrum analyzer receiver set to the range required for the measurement; the source frequency range is moved to cover the output range that the spectrum analyzer receiver would expect to see if the DUT were present (i.e. the displayed range). This is selected using the *[Display Freq Range]* soft key.

The third method is to press *[Reference Device]*; this stores the response of a designated reference device and subtracts it from the live trace. The effect is to generate a straight line response after completion of the cal process using the reference item. The DUT to be compared with the reference device is then substituted for the reference device and the resulting trace displays the difference between the DUT and the reference device. When the two are “identical” the resulting trace will be a straight line.

Continue

Starts the calibration process.

**Source
Freq Range**

The frequency range of the calibration corresponds to that of the source.

This soft key will only be displayed if offset/scaling has been applied (see Conversion Meas menu, page 3-59).

**Display
Freq Range**

The frequency range of the calibration corresponds to that of the spectrum analyzer receiver (i.e. the displayed range).

This soft key will only be displayed if offset/scaling has been applied (see Conversion Meas menu, page 3-59).

**Reference
Device**

Allows the user to store the response characteristic of a “known” device or “golden standard” in a calibration memory in order that devices under test may be compared with the reference device and adjusted to have the same or similar response characteristics.

This soft key will only be displayed if offset/scaling has been applied (see Conversion Meas menu, page 3-59).

Select Path Cal Store Leads to the Path Cal menu, which is used to select the path calibration store to be used for storing the calibration data .
See page 3-154.

Abort Terminates the calibration process. The current path cal store will not be affected.

CAL	Through Cal	Select Path Cal Store
CAL	Short AND Open Cal	Select Path Cal Store
CAL	Short OR Open Cal	Select Path Cal Store

Path Cal This menu is used to select the path calibration store to be used to save the calibration data.

A form is displayed listing the identities of the available path calibration stores. To save the data to a specific store, the store name is selected from the list. Alternatively, a new store can be created by entering a new name in the appropriate entry field.

As well as the store id, its associated date and time stamp are also displayed in the list. A section at the bottom of the form will display the descriptive text for the currently selected store in the list and state whether or not it is password protected.

OK Selects the current store.

↑ Selects the previous entry in the list of stores. The list automatically scrolls, if necessary, when the highlight reaches the top of the list.

This soft key will be unselectable if the highlight is at the beginning of the list/

↓ Selects the next entry in the list of stores. The list automatically scrolls, if necessary, when the highlight reaches the bottom of the list.

This soft key will be unselectable if the highlight is at the end of the list/

Return to Path Cal Returns to the previous menu.

CAL

Short AND
Open Cal**Short & Open**

This function is used to carry out a short / open path calibration on the currently active measurement. It calibrates the system against a known reference when measuring return loss. Open circuit and short circuit terminations are chosen, as both of these theoretically reflect 100% of the power incident upon them, and therefore have a return loss of 0 dB. If only one of these terminations is used for calibration, however, there is an uncertainty added to the measurements, due to test port impedance mismatch. This uncertainty is minimised by calibrating the system against both open and short circuits, and calculating the average path cal.

The user is first prompted to connect the short circuit termination. The [*Select Path Cal Store*] soft key is used to specify the path calibration store that is to be used for storing the calibration data. The [*Continue*] soft key starts the calibration process. When the short calibration data has been acquired, the user is prompted to connect the open termination, and to press [*Continue*] when ready. The user is informed when the open calibration data has been acquired, and the path calibration has been applied. The calibration data is stored in the specified path cal store. The function then terminates, and the user is returned to the Cal menu.

Continue

Starts the calibration process.

**Select Path
Cal Store**

Leads to the Path Cal menu, which is used to select the path calibration store to be used for storing the calibration data.

See page 3-154.

Abort

Used to terminate the calibration process at any time. The current path cal store will not be affected.

CAL

Short OR
Open Cal**Short or Open**

This function is similar to the Short & Open menu, except that a path cal is performed using either an open circuit or a short circuit termination. This method would be used, for example, in waveguide measurements, since a practical open circuit is not achievable for waveguide systems.

Continue

Starts the calibration process.

**Select Path
Cal Store**

Leads to the Path Cal menu, which is used to select the path calibration store to be used for storing the calibration data.

See page 3-154.

Abort

Used to terminate the calibration process at any time. The current path cal store will not be affected.

CAL

**Single Ended
Ins Loss**

S/E Ins Loss

This function is used to perform a single-ended insertion loss measurement.

This type of measurement can be used, for example, to check the insertion loss of a long transmission line, where simultaneous access to both ends of the line is impractical. In the single-ended insertion loss measurement, either a short circuit, an open circuit, or both are connected to the end of the line, so that, theoretically, 100% of the input power is reflected back to the source. A bridge or coupler at the input end of the line is used to measure the reflected signal. Since this signal is attenuated twice (once in each direction), the measurement of the total attenuation, in dB, is halved by the 6800A to produce a value for the insertion loss.

Note that since the reflected signal undergoes two stages of attenuation, this method is not suitable for high loss cables.

Upon completion of the calibration the display will represent the insertion loss of the line.

**Short AND
Open Cal**

Leads to the S/E IL S & O menu, which is used to perform a short / open path calibration for the single-ended insertion loss measurement. This functions in the same way as the Short AND Open menu.

See page 3-155.

**Short OR
Open Cal**

Leads to the S/E IL S OR O menu which is used to perform either a short circuit or an open circuit path calibration for the single-ended insertion loss measurement. This functions in the same way as the Short OR Open menu.

See page 3-155.

**Return to
Cal**

Returns to the Cal menu.

CAL

Apply Path
Cal**Apply Path Cal**

This menu is used to select the path calibration store from which the calibration data will be applied.

A form is displayed listing the identities of the available path calibration stores. To use the data from a specific store, the store name is selected from the list.

As well as the store id, its associated date and time stamp are also displayed in the list. A section at the bottom of the form will display the descriptive text for the currently selected store in the list and state whether or not it is password protected.

Select

Selects the current store.



Selects the previous entry in the list of stores. The list automatically scrolls, if necessary, when the highlight reaches the top of the list.

This soft key will be unselectable if the highlight is at the beginning of the list.



Selects the next entry in the list of stores. The list automatically scrolls, if necessary, when the highlight reaches the bottom of the list.

This soft key will be unselectable if the highlight is at the end of the list.

**Return to
Cal**

Returns to the Calibration menu.

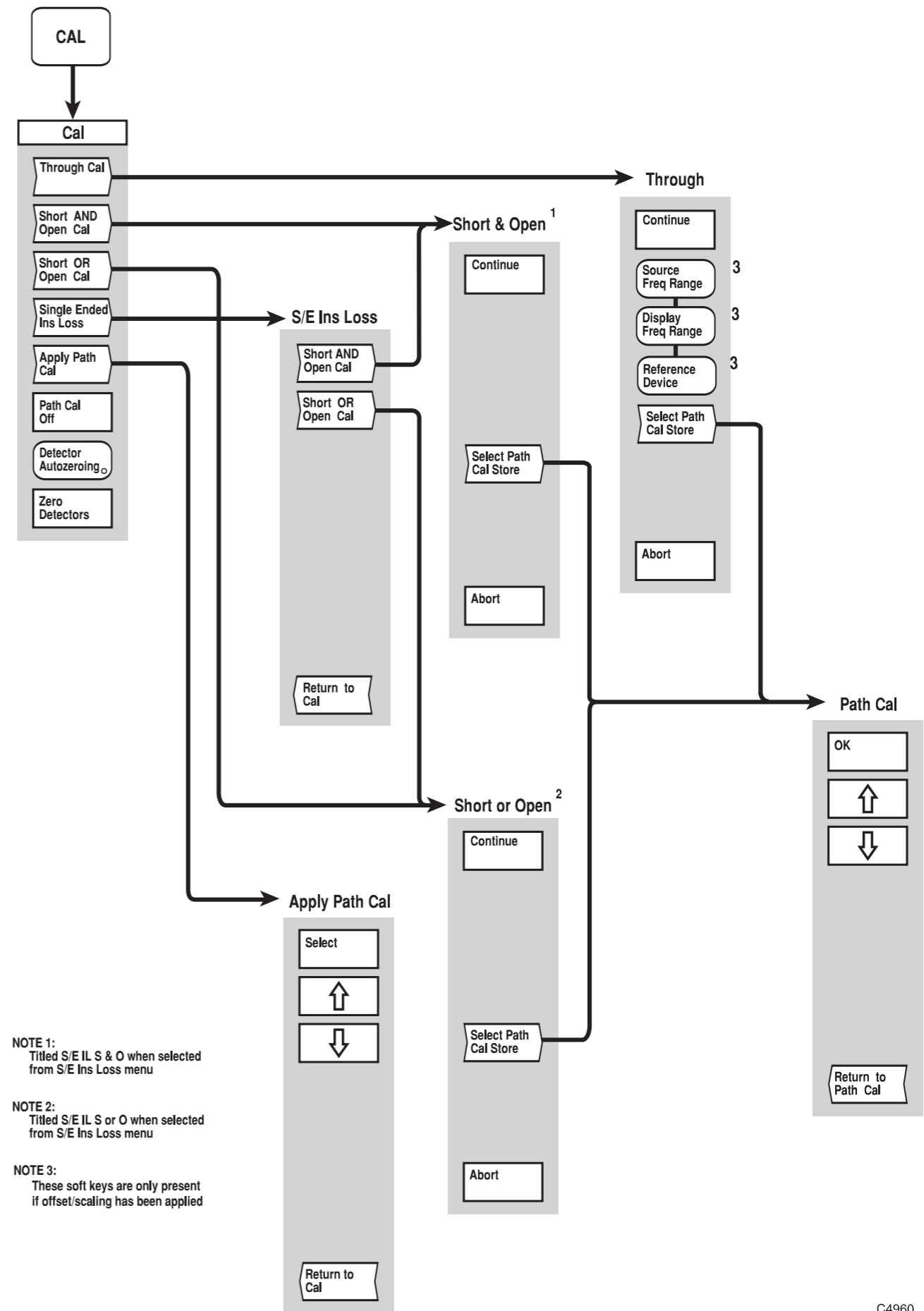

C4960

Fig. 3-26 CAL menus - scalar channel

Fig. 3-26 CAL menus - scalar channel

[SCALE / FORMAT] key

The [SCALE / FORMAT] key enables the active measurement to be displayed in the required format, i.e. the units in which the response (vertical axis) is displayed. The options available depend on the type of measurement. The menu also enables the vertical positioning and scaling to be adjusted, or allows the instrument to set the position and scaling automatically.

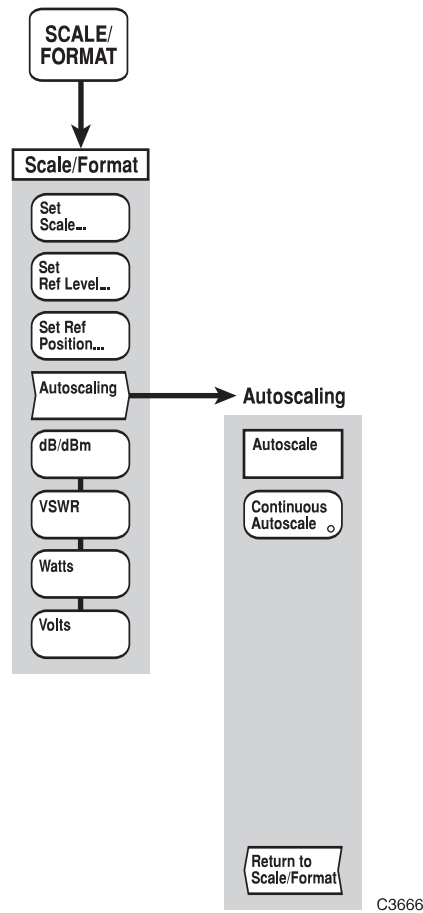

Fig. 3-27 SCALE / FORMAT menu - scalar channel

SCALE / FORMAT

Scale / Format

This menu enables the user to select the measurement units, and to set the positioning and scaling for a trace.

The reference position is the position on the vertical axis that remains fixed during scaling. This is indicated on the screen by the Reference Position Indicator. The reference level is the value corresponding to the position of the Reference Position Indicator on the vertical scale, and is displayed in the relevant trace information area, together with the scaling factor.

The default values for reference level, scaling and reference position for each format are listed below.

Format	Reference Level	Scaling	Reference Position
dB and dBm	0 dB(m)	10 dB(m)/div	Top line
VSWR	1	0.2 /div	Bottom line
Watts	100 mW	10 mW/div	Top line
Volts	1 V	0.1 V/div	Top line
Delay	0	2 μ s/div	Centre line

The display format can be set up independently for each trace of the active channel. The formats permitted depends on the type of measurement.

Note

The Delay (time) format cannot be directly selected; it is applied by default whenever a Group Delay measurement is performed. The [dB / dBm], [VSWR], [Watts] and [Volts] soft keys are unselectable for Group Delay measurements, since the measurement is always displayed using time units.

Set Scale

Sets the scale factor for the currently active trace.

dB/dBm and VSWR format

Rotary Control	✓	Step Keys	✓	=Marker	✗	Numeric Pad	✓	Terminator	Any
----------------	---	-----------	---	---------	---	-------------	---	------------	-----

Watts and Volts formats

Rotary Control	✓	Step Keys	✓	=Marker	✗	Numeric Pad	✓	Terminator	10-
----------------	---	-----------	---	---------	---	-------------	---	------------	-----

The step keys change the scaling in a 1, 2, 5... sequence, for all formats.

Set Ref Level

Sets the reference level for the currently active trace.

dB/dBm format

Rotary Control	✓	Step Keys	✓	=Marker	✓	Numeric Pad	✓	Terminator	Any
----------------	---	-----------	---	---------	---	-------------	---	------------	-----

VSWR, Watts and Volts formats

Rotary Control	✓	Step Keys	✓	=Marker	✓	Numeric Pad	✓	Terminator	10-
----------------	---	-----------	---	---------	---	-------------	---	------------	-----

The reference level can also be set to the response measured at the active marker position, by pressing this soft key followed by the [ENTER / =MKR] key on the numeric keypad.

Set Ref Position	<p>Sets the reference position for the currently active trace. The reference position may be placed on any of the 11 horizontal lines on the graticule.</p> <table border="1" style="width: 100%; border-collapse: collapse;"> <tr> <td style="padding: 2px;">Rotary Control</td> <td style="padding: 2px;">√</td> <td style="padding: 2px;">Step Keys</td> <td style="padding: 2px;">√</td> <td style="padding: 2px;">=Marker</td> <td style="padding: 2px;">×</td> <td style="padding: 2px;">Numeric Pad</td> <td style="padding: 2px;">×</td> <td style="padding: 2px;">Terminator</td> <td style="padding: 2px;">×</td> </tr> </table>	Rotary Control	√	Step Keys	√	=Marker	×	Numeric Pad	×	Terminator	×
Rotary Control	√	Step Keys	√	=Marker	×	Numeric Pad	×	Terminator	×		
Autoscaling	<p>Leads to the Autoscaling menu. <i>See page 3-163.</i></p>										
dB / dBm	<p>Selects dB/dBm format. The instrument will automatically select dB or dBm depending on whether the measurement is a ratio of inputs (relative power measurement), or a single input (absolute power measurement). The dB format is also selected if path calibration is applied, or if the measurement is made relative to a memory.</p> <p><i>This soft key will only be selectable for absolute or relative power measurements.</i></p>										
VSWR	<p>Selects VSWR format.</p> <p><i>This soft key will only be selectable for relative power measurements (i.e. a ratio).</i></p>										
Watts	<p>Selects Watts format.</p> <p><i>This soft key will only be selectable for absolute power measurements.</i></p>										
Volts	<p>Selects Volts format. The instrument displays the DC voltage output from a voltage measurement cable connected to a scalar input(optional accessory 54311/170 or 54311/112).</p> <p><i>This soft key will only be selectable for single input power measurements.</i></p>										

SCALE / FORMAT**Autoscaling**

Autoscaling **This menu provides Autoscale and Continuous Autoscale functions.**

Autoscale	<p>Allows the instrument to determine optimum values of scaling and reference level. The values are selected from a 1, 2, 5 sequence in order to display the measurement at approximately 80% of the graticule height. The value chosen for the reference level will be a multiple of the scaling factor. The reference position will remain unchanged.</p>
Continuous Autoscale	<p>Toggles continuous autoscale on or off. When turned on, autoscaling will be performed automatically, once per measurement update.</p>
Return to Scale / Format	<p>Returns to the Scale / Format menu.</p>

[MARKER] key

Markers provide numerical readout of trace data and allows various types of measurement to be performed.

The marker menus are shown in Fig. 3-29.

MARKER

<u>Marker</u>	This menu provides facilities for setting up markers, and using them to perform various types of measurement.
Active Mkr to Maximum	Places the active marker at the maximum point on the displayed trace.
Active Mkr to Minimum	Places the active marker at the minimum point on the displayed trace.
Max/Min Tracking	Leads to the Max/Min menu. <i>See page 3-167.</i>
Pk-Pk	Leads to the Pk-Pk menu. <i>See page 3-168 and 3-169.</i>
Mkr Functions	Leads to the Mkr Funcs menu, which enables various measurement functions to be carried out by means of the markers. <i>See page 3-171.</i>
Active Mkr	Toggles the active marker on or off. Turning off the active marker also turns off the delta marker. Once the active marker is turned on it can be positioned anywhere along the trace, using the rotary control. To set the active marker to a specific domain value, using the numeric keypad, the [<i>Position Active Mkr</i>] soft key must be selected..
Delta Mkr	Leads to the Delta Marker menu. <i>See page 3-175.</i>
More	Leads to the second page of the Marker menu. <i>See page 3-166.</i>

MARKER

More

Marker

This menu provides additional facilities for setting up markers.

Large Readout

Toggles large readout mode on or off. When on, the active marker spot reading is displayed using large digits, so that it may be read at a distance. The large digit readout is only generated for the active measurement on the active channel.

This soft key will only be selectable if the active marker is turned on.

Mkr Table

Toggles display of the marker table on or off. The table is displayed below the graticule and shows the domain and response values for all markers currently displayed (apart from the delta marker) on the active channel. The absolute value of the responses is shown regardless of whether the delta marker is in use.

All Mkrs Off

Turns all the markers off.

Place Mkr at Active

Used to place a marker at the active marker position by entering the required marker number.

Rotary Control	×	Step Keys	×	=Marker	×	Numeric Pad	√	Terminator	None
----------------	---	-----------	---	---------	---	-------------	---	------------	------

This soft key will only be selectable if the active marker is turned on.

Position Active Mkr

Used to change the domain value (x-axis position) of the active marker, by entering a new value.

Frequency

Rotary Control	√	Step Keys	√	=Marker	×	Numeric Pad	√	Terminator	10+
----------------	---	-----------	---	---------	---	-------------	---	------------	-----

Power

Rotary Control	√	Step Keys	√	=Marker	×	Numeric Pad	√	Terminator	Any
----------------	---	-----------	---	---------	---	-------------	---	------------	-----

This soft key will only be selectable if the active marker is turned on.

Assign Active Mkr 1-8

Used to select which is to be the active marker. The selection applies instrument wide.

Rotary Control	×	Step Keys	×	=Marker	×	Numeric Pad	√	Terminator	None
----------------	---	-----------	---	---------	---	-------------	---	------------	------

Set Up Mkrs

Leads to the Set Up Mkrs menu, which allows the user to activate and position selected markers.

See page 3-176.

Return to Prior Menu

Returns to the first page of the Marker menu.

MARKER

Max/Min
Tracking**Max/Min**

This menu is used to set the max / min tracking mode.

When the tracking facility is turned on, the selected function is applied automatically at the end of each sweep, continually updating the active marker position.

**Tracking
Maximum**

Applies tracking to the maximum function.

**Tracking
Minimum**

Applies tracking to the minimum function.

**Tracking
Off**

Disables tracking.

**Return to
Marker**

Returns to the Marker menu.

MARKER

Pk - Pk

Pk - Pk (Scalar / Tuned Input) **This menu provides peak-to-peak functions for measurements using the scalar inputs (A, B, C) or the tuned input (spectrum analyzer).**

A sub-range of the displayed frequency sweep can be specified. When enabled, the peak-to-peak measurement will be restricted to the sub-range, otherwise the entire span will be used. The following markers are placed on the trace to indicate the sub-range end points: ▷ ◁

Find Pk-Pk Initiates a peak-to-peak measurement, placing the active marker at the trace maximum and the delta marker at the trace minimum. The measurement is also displayed in a form, overlaying the graticule. The form is removed if there is any change in the trace or markers, or if the [ENTRY OFF] key is pressed.

Pk-Pk Tracking Toggles tracking on or off. When enabled, the peak-to-peak function is applied automatically at the end of each sweep, thus continually updating the peak-to-peak measurement.

Use Sub-range Used to enable/disable the sub-range function. If a sub-range is enabled, the peak-to peak function will be restricted to that range. The sub-range is specified by entering the required start/stop or centre/span values.

Centre / span disabled

Set Sub-range Start Used to enter the start frequency of the sub-range
 Rotary Control ✓ Step Keys ✓ =Marker ✗ Numeric Pad ✓ Terminator 10+

Set Sub-range Stop Used to enter the stop frequency of the sub-range
 Rotary Control ✓ Step Keys ✓ =Marker ✗ Numeric Pad ✓ Terminator 10+

Centre / span enabled

Set Sub-range Cntr Used to enter the centre frequency of the sub-range
 Rotary Control ✓ Step Keys ✓ =Marker ✗ Numeric Pad ✓ Terminator 10+

Set Sub-range Span Used to enter the span of the sub-range
 Rotary Control ✓ Step Keys ✓ =Marker ✗ Numeric Pad ✓ Terminator 10+

Cntr / Span When [Cntr / Span] is enabled, measurement sub-range may be entered in centre / span form. When it is disabled, however, the sub-range may be entered in start / stop form.

Return to Marker Returns to the Marker menu.

MARKER

Pk - Pk

Pk - Pk
(Group Delay)

This menu provides peak-to-peak and deviation functions for group delay measurements.

A sub-range of the displayed frequency sweep can be specified. When enabled, the peak-to-peak delay and deviation measurements will be restricted to the sub-range, otherwise the entire span will be used. The following markers are placed on the trace to indicate the sub-range end points: ▷ ◁

The [*Set Bandwidth*] soft key is used to set the bandwidth of the frequency window that is used for measurements of Pk - Pk delay. The window is moved over the frequency sweep (or sub-range) one measurement point at a time and the Pk - Pk function is applied to the measurement points covered by the window for each of its positions. The active and delta markers are placed at the maximum and minimum values respectively for the worst case position of the window.

Using the sub-range and bandwidth parameters, a typical requirement might be to check for less than 5 ns peak-to-peak delay in any 10 MHz bandwidth between 1.3 GHz and 1.7 GHz.

Pk-Pk Delay

Turns the Pk - Pk Delay measurement on and off. When it is enabled, the active and delta markers are placed at the location of the maximum and minimum delay values within the sub-range (or the entire span if the sub-range is disabled).

Set Bandwidth

This setting represents the bandwidth of the measurement window (default is 20 MHz).

Rotary Control	√	Step Keys	√	=Marker	×	Numeric Pad	√	Terminator	10+
----------------	---	-----------	---	---------	---	-------------	---	------------	-----

Use Sub-range

Used to enable/disable the sub-range function. If a sub-range is enabled, the peak-to peak (and Deviation) function will be restricted to that range. The sub-range is specified by entering the required start/stop or centre/span values.

Centre / span disabled

Set Sub-range Start

Used to enter the start frequency of the sub-range

Rotary Control	√	Step Keys	√	=Marker	×	Numeric Pad	√	Terminator	10+
----------------	---	-----------	---	---------	---	-------------	---	------------	-----

Set Sub-range Stop

Used to enter the stop frequency of the sub-range

Rotary Control	√	Step Keys	√	=Marker	×	Numeric Pad	√	Terminator	10+
----------------	---	-----------	---	---------	---	-------------	---	------------	-----

Centre / span enabled

Set Sub-range Cntr

Used to enter the centre frequency of the sub-range

Rotary Control	√	Step Keys	√	=Marker	×	Numeric Pad	√	Terminator	10+
----------------	---	-----------	---	---------	---	-------------	---	------------	-----

Set Sub-range Span

Used to enter the span of the sub-range

Rotary Control	√	Step Keys	√	=Marker	×	Numeric Pad	√	Terminator	10+
----------------	---	-----------	---	---------	---	-------------	---	------------	-----

Cntr / Span

When [*Cntr / Span*] is enabled, measurement sub-range may be entered in centre / span form. When it is disabled, however, the sub-range may be entered in start / stop form.

Measure Deviation Leads to the Deviation menu.
See page 3-170.
This soft key is only present for group delay measurements.

Return to Marker Returns to the Marker menu.



Deviation This menu provides additional measurement functions for group delay
Measurements performed over the sub-range defined on the Pk - Pk menu.

Linear Displays the *deviation from linear* (i.e. first derivative of the delay v. frequency function) within the sub-range. The active marker is placed at the point where the absolute value of the first derivative is a maximum (i.e. maximum slope of delay/frequency function).

Parabolic Displays the *deviation from parabolic* (i.e. second derivative of the delay v. frequency function) within the sub-range. The active marker is placed at the point where the absolute value of the second derivative is a maximum.

Off Disables the Deviation function.

Return to Pk - Pk Returns to the Pk - Pk menu.

MARKER

Mkr
Functions**Mkr Funcs**

This menu leads to sub-menus for searching for a specified response value and performing bandwidth measurements. It also allows the slope of a trace to be measured and provides a marker function to facilitate gain compression measurements.

Note For Group Delay measurements, only the Search function is available. The 1 dB Gain Compression function is only available for scalar input, power sweep measurements.

Search

Leads to the Search menu, which is used to locate a particular response value on a trace. See page 3-172.

Bandwidth

Leads to the Bandwidth menu, which is used for bandwidth measurements. See page 3-173.

This soft key is only selectable if the format is dB/dBm, and the sweep type is frequency.

**1 dB Gain
Compression**

This function takes the measurement at the active marker then searches right for the point at which the response has fallen by 1 dB; the active marker is then placed at that point. This is useful for amplifier gain compression measurements, where it is required to know the input power at which the gain has dropped by 1 dB.

dB/Octave

Sets up the marker response field to display the slope of the trace, at the active marker position, in dB per octave. The response value is followed by /**O** to indicate that this function is active. This function applies per measurement.

dB/Decade

Sets up the marker response field to display the slope of the trace, at the active marker position, in dB per decade. The response value is followed by /**D** to indicate that this function is active. This function applies per measurement.

Off

Turns off the dB/Octave or dB/Decade function and restores the normal marker response display.

**Return to
Marker**

Returns to the Marker menu.

MARKER

**Mkr
Functions**

Search

Search

This menu is used for locating a response value on a trace that has been specified by the user. The search facility can also be used in delta marker mode.

**Search
Left**

Causes the system to search left from the active marker position, in order to find the response value specified using the *[Set Search Value]* soft key. The active marker will be placed at this position. If two adjacent measurement points encompass the search value, the active marker will be placed at the measurement point which is nearer to the search value. If the search value is not found, a message will be displayed indicating this, and the active marker will remain where it is.

**Search
Right**

As above, but the search direction is right.

**Set Search
Value**

Sets the value that will be searched for. If the delta marker is off, this will be treated as a response value. If the delta marker is on, however, it will be treated as a value relative to the delta marker response.

dB/dBm format

Rotary Control	✓	Step Keys	✓	=Marker	✗	Numeric Pad	✓	Terminator	Any
----------------	---	-----------	---	---------	---	-------------	---	------------	------------

VSWR, Watts and Volts formats

Rotary Control	✓	Step Keys	✓	=Marker	✗	Numeric Pad	✓	Terminator	10-
----------------	---	-----------	---	---------	---	-------------	---	------------	------------

**Return to
Mkr Funcs**

Returns to the Mkr Funcs menu.

MARKER

Mkr
Functions

Bandwidth

Bandwidth

This menu enables the n dB bandwidth to be determined for a trace, where n is a positive or negative value entered by the user.

Starting at the active marker position, search operations are performed in both directions using the method described for the Search menu. If both searches are successful, the two highest numbered markers, other than the active marker, are placed at the upper and lower n dB positions; and the bandwidth, centre frequency, and, optionally, centre frequency divided by bandwidth (i.e. Q factor), are displayed.

If the tracking facility is turned on, the bandwidth search is invoked automatically at the end of each sweep, continually updating the bandwidth measurement.

The Fig. 3-28 shows an example of the displayed results of a bandwidth measurement on a band-pass filter.

**Bandwidth
Search**

Initiates a bandwidth search and displays the results in a form, overlaying the graticule. The form is removed if there is any change in the measurement, or markers, or if the [ENTRY OFF] key is pressed.

**Set n dB
Value**

Used to set the n dB down (or up) value for the bandwidth search.

Rotary Control	<input checked="" type="checkbox"/>	Step Keys	<input checked="" type="checkbox"/>	=Marker	<input checked="" type="checkbox"/>	Numeric Pad	<input checked="" type="checkbox"/>	Terminator	<input checked="" type="checkbox"/>	Any
----------------	-------------------------------------	-----------	-------------------------------------	---------	-------------------------------------	-------------	-------------------------------------	------------	-------------------------------------	-----

**Display
CF / Δ F**

Toggles the display of centre frequency divided by bandwidth on or off. This selection applies instrument-wide.

**Bandwidth
Tracking**

Toggles tracking on or off.

**Remove
Results Window**

Removes the window that displays the results of the bandwidth search.

**Return to
Mkr Funcs**

Returns to the Mkr Funcs menu.

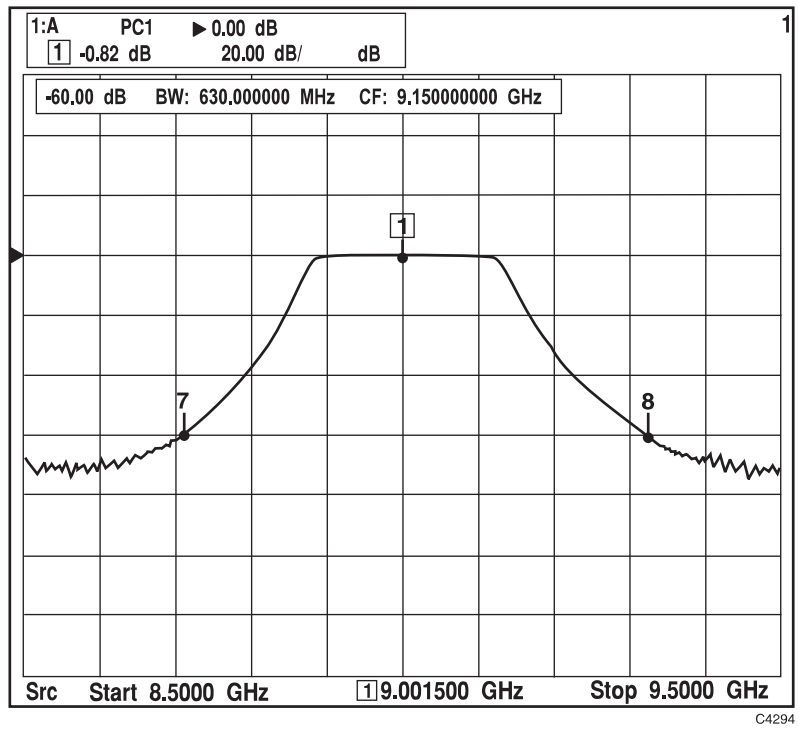

Fig. 3-28 Bandwidth measurement of a band-pass filter

MARKER

Delta
Mkr**Delta Marker**

This menu provides facilities for setting up the delta marker.

**Delta
Mkr**

Toggles the delta marker on or off. Turning on the delta marker also turns on the active marker, and the initial position of the delta marker is the same as that of the active marker.

**Position
Delta Mkr**

Used to change the domain value (x-axis position) of the delta marker, by entering a new value.

Rotary Control	√	Step Keys	√	=Marker	×	Numeric Pad	√	Terminator	10+
----------------	---	-----------	---	---------	---	-------------	---	------------	-----

This soft key will only be selectable if the delta marker is turned on.

**Fixed
Delta**

When this function is enabled, the spacing between the active and delta markers remains fixed when either is moved.

**Return to
Marker**

Returns to the Marker menu.

MARKER

More

**Set Up
Mkrs**

Set Up Mkrs

This function provides facilities for setting up all the markers.

A form is displayed showing, for each marker (including the delta marker), whether it is on or off, its position (shown by ‘-’ if it is off) and whether or not it is the active marker.

The [\uparrow] and [\downarrow] soft keys are used to highlight the marker to be set up.

**Marker
On**

Turns the selected marker on or off.

\uparrow

Selects the previous marker

\downarrow

Selects the next marker

**Make
Active**

Makes the selected marker the active on

This soft key will only be selectable if the marker is turned on and it is not the delta marker.

**Return to
Marker**

Returns to the Marker menu.

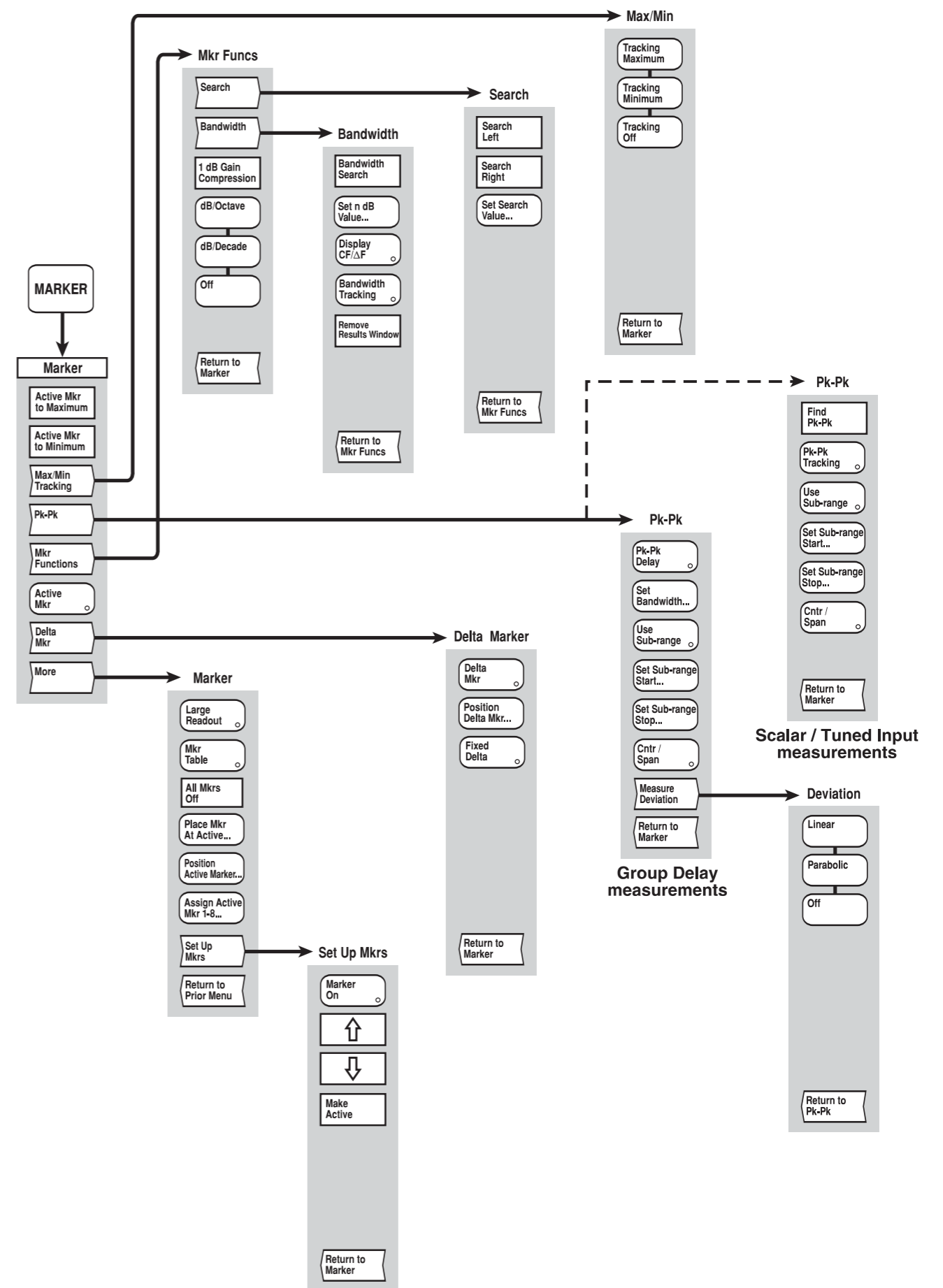

C4850

Fig. 3-29 MARKER menus - scalar channel

Fig. 3-29 MARKER menus - scalar channel

SETUP & ANALYSIS GROUP KEYS (Fault Location Channel)

[SOURCE] key

The [SOURCE] key provides access to the menus shown in Fig. 3-30. Owing to the nature of fault location measurements, some of the source functions are set from the Config Meas menu accessed via the [FAULT LOCATION] key (i.e. start/stop frequencies, number of measurement points). The source is turned on and off by means of the [SOURCE ON/OFF] key.

A Source Only Mode is available in which the data acquisition system is turned off and the 6800A acts solely as a source. When in this mode, the various source settings are displayed, and all front panel keys, with the exception of the numeric keypad, units terminator keys and the [PRESET] key, will be locked out. Normal operation is restored by pressing the *[Exit Source Only Mode]* soft key on the Source menu or using the [PRESET] key.

SOURCE

Source This menu allows the operator to set up the source for fault location measurements on coaxial or waveguide transmission lines.

The sweep time is the time taken for the source to complete one sweep, excluding retrace time and the time required for internal processing of the data. The setting determined by this menu will apply instrument-wide, i.e. to all displayed traces. Longer sweep times have the effect of reducing noise.

Set Output Power Used to adjust the output power of the source, for the currently active channel.

Rotary Control	√	Step Keys	√	=Marker	×	Numeric Pad	√	Terminator	Any
----------------	---	-----------	---	---------	---	-------------	---	------------	------------

Automatic Sweep Time In this mode, the sweep time automatically adjusts to the minimum sweep time available for the set frequency span and number of measurement points.

User Set Sweep Time Sets the sweep time mode to manual; the following soft key can then be pressed to allow the sweep time to be changed by the operator.

Set Sweep Time Allows a sweep time to be entered. The 6800A will generate an actual sweep time that will never be faster than the sweep time entered, but may be slower, depending on constraints imposed by the number of measurement points, source frequency range and measurement definition.

Rotary Control	√	Step Keys	√	=Marker	×	Numeric Pad	√	Terminator	10-
----------------	---	-----------	---	---------	---	-------------	---	------------	------------

This key will only be selectable if manual sweep time mode has been selected.

Enter Source Only Mode Puts the instrument into source only mode, in which the 6800A acts solely as a source. The source parameters are displayed, as shown in Fig. 3-24. All front panel keys, with the exception of the numeric keypad, units terminator keys and the [PRESET] key are locked out. The label for this soft key changes to *[Exit Source Only Mode]*.

or

Exit Source Only Mode Returns the instrument to the measurement mode it was in before source only mode was entered. The label for this soft key is restored to *[Enter Source Only Mode]*.

More Leads to the second page of the Source menu.
This menu is the same as that for scalar channels. See page 3-133.

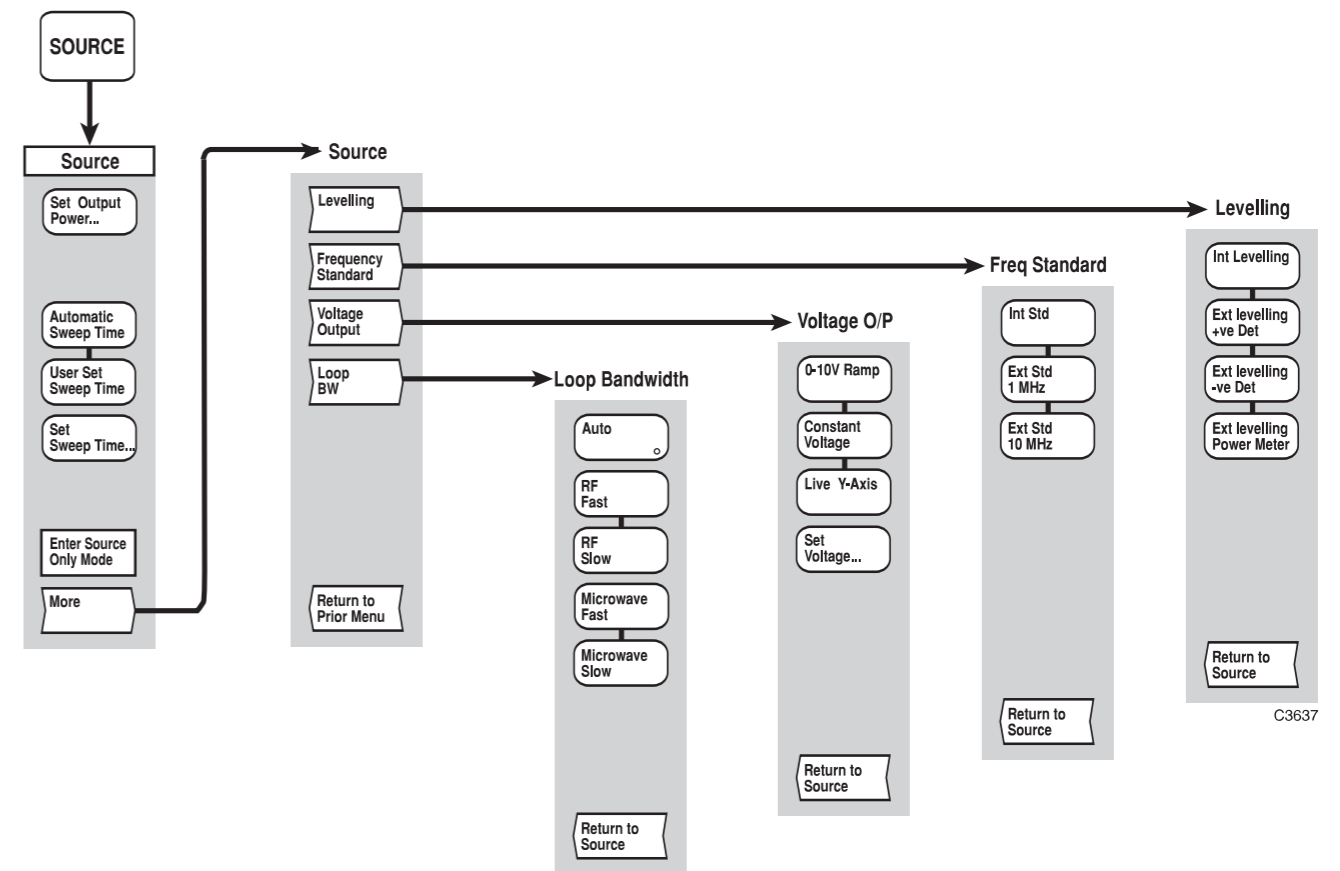

C3637

Fig. 3-30 SOURCE menus - fault location channel

Fig. 3-30 SOURCE menus - fault location channel

[CAL] key

The [CAL] key provides access to the calibration menus shown in Fig. 3-31. Calibration is used prior to a measurement in order to remove system errors that cause uncertainty in measuring the cable/waveguide under test. The resulting path calibration is stored and is applied to the current measurement. This results in the current measurement data being ratioed with the path calibration data, before being formatted and displayed.

One of four stored path calibrations can be applied to the current measurement. It is possible to apply the path calibration obtained on one channel, to the other channel. This is useful if, say, Zoom mode is being used to display one section of a cable run in one channel, and another section in the second channel.

If any of the following parameters are changed, subsequent to calibration, the calibration will become invalid. An error message will be displayed, and the measurement will not update. Restoration of the original values will allow the calibration to be used again (see Fault Loc menu, [Recall Cal Conditions] soft key).

- Range, Centre Frequency
- Start / Stop Frequency
- Waveguide Cutoff Frequency
- Number of Points
- Source Power Level

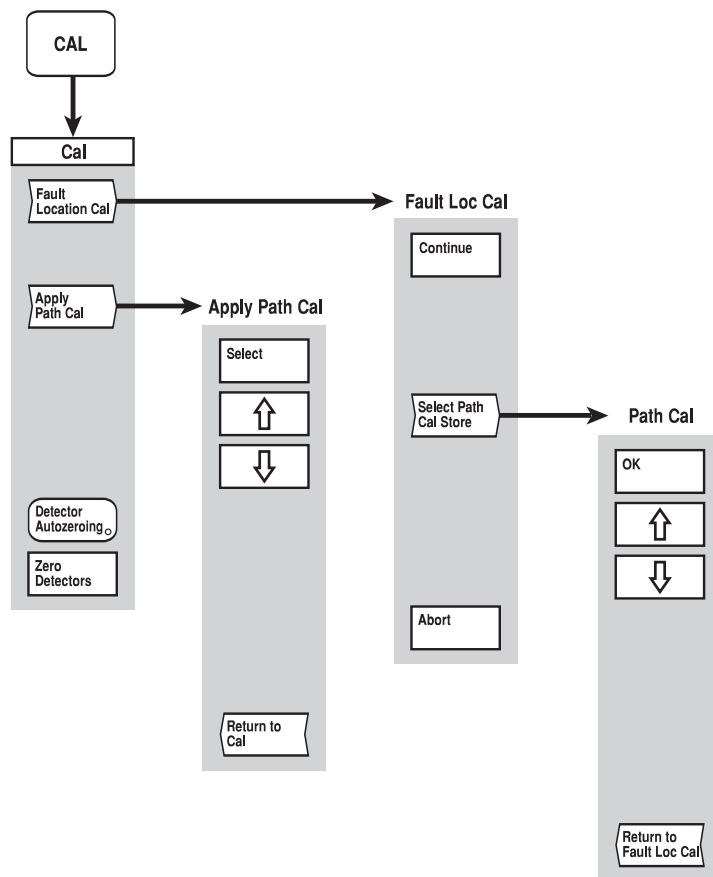

C3638

Fig. 3-31 CAL menus - fault location channel

CAL

- Cal** **This menu provides facilities for calibrating the measurement system for a fault location channel, and applying any of the stored path calibrations to a measurement. It also provides a detector zeroing function.**
- Fault Location Cal** Leads to the Fault Loc Cal menu.
See page 3-185.
- This soft key will be unselectable if the trace is a measurement store.*
- Apply Path Cal** Enables one of the stored path calibrations to be selected, and applied to the measurement. This function provides the same functions as the scalar Apply Path Cal menu (page 3-157).
- This soft key will be unselectable if the trace is a measurement store.*
- Detector Autozeroing** Zeroing is used to remove the effects of zero drift from the measurement. It is especially important for low level measurements (< -40 dBm). At very low levels (< -60 dBm), zeroing should be performed every few minutes, but preferably the autozeroing facility should be used.
- The *[Detector Autozeroing]* soft key toggles autozeroing on and off. When it is turned on, the detectors will be zeroed automatically, once every measurement update. The instrument momentarily turns off the RF in order to do this. The setting of this parameter applies instrument-wide, and the **AZ** indicator is displayed in the General Information Area when autozeroing is on.
- The autozeroing facility only operates if a manual zero has previously been performed (see *[Zero Detectors]* below).
- Zero Detectors** Initiates manual zeroing of the detectors. A zero will be performed on all inputs, including any that do not have a detector connected. If a detector is then connected to one of the previously unused inputs, the zero is no longer valid, and misleading results could occur. It is therefore necessary to perform a detector zero each time a detector is connected to an input.
- The source will be automatically turned off during a detector zero. If a source other than the 6800A is providing the RF signal, it must be turned off before performing a zero.

CAL

Fault
Location Cal**Fault Loc Cal**

This menu is used to carry out a path calibration for the fault location measurement. It compensates for residual levelling errors in the source, and frequency variations in the components that form the measuring system.

The user is prompted to connect a matched load to the test port of the 6240. The [*Select Path Cal Store*] soft key is used to specify the path calibration store that is to be used for storing the calibration data. The [*Continue*] soft key starts the calibration process. A detector zero is automatically performed, followed by calibration of the measurement system. The user is informed when the calibration data has been acquired, stored and applied. The function then terminates, and the user is returned to the Cal menu.

The [*Abort Calibration*] soft key may be used to terminate the calibration process before the selected path cal store is overwritten.

Continue

Starts the calibration process.

**Select Path
Cal Store**

Used to select the path calibration store to be used for storing the calibration data. This menu provides the same functions as the Path Cal menu for the scalar Through path calibration (page 3-154).

Abort

Terminates the calibration process; the selected path cal store is not affected.

[SCALE / FORMAT] key

The [SCALE / FORMAT] key enables the fault location trace to be displayed in the required format, i.e. the units in which the response (vertical axis) is displayed. The menu also enables the vertical positioning and scaling to be adjusted, or allows the instrument to set the position and scaling automatically.

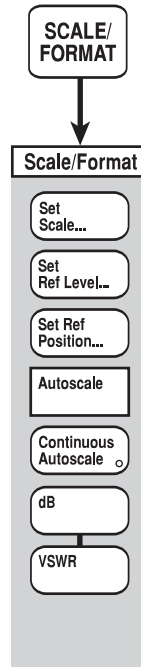

C3640

Fig. 3-32 SCALE / FORMAT menu - fault location channel

SCALE / FORMAT

Scale / Format

This menu enables the user to select the measurement units, and to set the positioning and scaling for a trace.

The reference position is the position on the vertical axis that remains fixed during scaling. This is indicated on the screen by the Reference Position Indicator. The reference level is the value corresponding to the position of the Reference Position Indicator on the vertical scale, and is displayed in the relevant trace information area, together with the scaling factor.

The default values for the reference level, scaling and reference position for both formats are listed below.

Format	Reference Level	Scaling	Reference Position
dB	0 dB	10 dB /div	Top line
VSWR	1	0.2 /div	Bottom line

Set Scale

Sets the scale for the measurement.

dB format

Rotary Control	✓	Step Keys	✓	=Marker	✗	Numeric Pad	✓	Terminator	Any
----------------	---	-----------	---	---------	---	-------------	---	------------	-----

VSWR format

Rotary Control	✓	Step Keys	✓	=Marker	✗	Numeric Pad	✓	Terminator	10-
----------------	---	-----------	---	---------	---	-------------	---	------------	-----

Set Ref Level

Sets the reference level (at the reference position) for the measurement . Numeric entry as above.

The reference level can also be set to the response measured at the active marker position, by pressing this soft key, followed by [ENTER / =MKR].

Set Ref Position

Sets the reference position for the measurement to a chosen graticule division on the vertical axis.

Rotary Control	✓	Step Keys	✓	=Marker	✗	Numeric Pad	✗	Terminator	✗
----------------	---	-----------	---	---------	---	-------------	---	------------	---

Autoscale

Allows the instrument to determine optimum values of scale and reference level. The reference position will remain unchanged.

Continuous Autoscale

When selected, autoscaling will be performed once per measurement update.

dB

Selects dB format.

VSWR

Selects VSWR format.

[MARKER] key

Markers provide numerical readout of trace data and allows various types of measurement to be performed.

The marker menus are shown in Fig. 3-33.

MARKER

<u>Marker</u>	<p>This menu provides facilities for setting up markers, and using them to perform various types of measurement.</p> <p>The Peak Level function is used to set the threshold value when locating peaks on the trace.</p>
Find Maximum	Places the active marker at the maximum point on the displayed trace.
Identify Peaks	Finds the eight highest peaks, and identifies them with markers. The marker table is displayed, the active marker is placed at the highest peak on the active trace, and the remaining markers are placed at the next highest peaks.
Next Peak Left	Places the active marker at the next peak to the left of its current position.
Next Peak Right	Places the active marker at the next peak to the right of its current position.
Peak Level	Leads to the Peak Level menu <i>See page 3-191.</i>
Active Mkr	Toggles the active marker on or off. Turning off the active marker also turns off the delta marker. Once the active marker is turned on it can be positioned anywhere along the trace, using the rotary control. To set the active marker to a specific domain value, using the numeric keypad, the <i>[Position Active Mkr]</i> soft key must be selected.
Delta Mkr	Leads to the Delta Marker menu. <i>See page 3-191.</i>
More	Leads to the second page of the Marker menu. <i>See page 3-190.</i>

MARKER

More

Marker)

This menu provides additional facilities for setting up markers.

Large Readout

Toggles large readout mode on or off. When on, the active marker spot reading is displayed using large digits, so that it may be read at a distance. The large digit readout is only generated for the active measurement on the active channel.

This soft key will only be selectable if the active marker is turned on.

Mkr Table

Toggles display of the marker table on or off. The table is displayed below the graticule and shows the domain and response values for all markers currently displayed (apart from the delta marker) on the active channel. The absolute value of the responses is shown regardless of whether the delta marker is in use.

All Mkrs Off

Turns all the markers off.

Place Mkr at Active

Used to place a marker at the active marker position by entering the required marker number.

Rotary Control	×	Step Keys	×	=Marker	×	Numeric Pad	√	Terminator	Any
----------------	---	-----------	---	---------	---	-------------	---	------------	-----

This soft key will only be selectable if the active marker is turned on.

Position Active Mkr

Used to change the domain value (x-axis position) of the active marker, by entering a new value.

Rotary Control	√	Step Keys	√	=Marker	×	Numeric Pad	√	Terminator	10+
----------------	---	-----------	---	---------	---	-------------	---	------------	------------

This soft key will only be selectable if the active marker is turned on.

Assign Active Mkr 1-8

Used to select which is to be the active marker. The selection applies instrument wide.

Rotary Control	×	Step Keys	×	=Marker	×	Numeric Pad	√	Terminator	Any
----------------	---	-----------	---	---------	---	-------------	---	------------	-----

Set Up Mkrs

Leads to the Set Up Mkrs menu, which allows the user to activate and position selected markers. This is the same as for a scalar channel.

See page 3-176.

Return to Prior Menu

Returns to the first page of the Marker menu.

MARKER

Peak Level

Peak Level This menu is used to set the threshold value when searching for peaks on the trace.

Peak Level Activates/disables the peak level threshold value.

Set Peak Level Used to set the level below which Next Peak Right and Next Peak Left will not recognise a peak.

dB format

Rotary Control	√	Step Keys	√	=Marker	√	Numeric Pad	√	Terminator	Any
----------------	---	-----------	---	---------	---	-------------	---	------------	------------

VSWR format

Rotary Control	√	Step Keys	√	=Marker	√	Numeric Pad	√	Terminator	10-
----------------	---	-----------	---	---------	---	-------------	---	------------	------------

Return to Marker Returns to the Marker menu.

MARKER

Delta Mkr

Delta Marker This menu provides facilities for setting up the delta marker.

Delta Mkr Toggles the delta marker on or off. Turning on the delta marker also turns on the active marker.

Position Delta Mkr Used to change the domain value (x-axis position) of the delta marker, by entering a new value.

Rotary Control	√	Step Keys	√	=Marker	✗	Numeric Pad	√	Terminator	10+
----------------	---	-----------	---	---------	---	-------------	---	------------	------------

This soft key will only be selectable if the delta marker is turned on.

Fixed Delta When this function is enabled, the spacing between the active and delta markers remains fixed when either is moved.

Return to Marker Returns to the Marker menu.

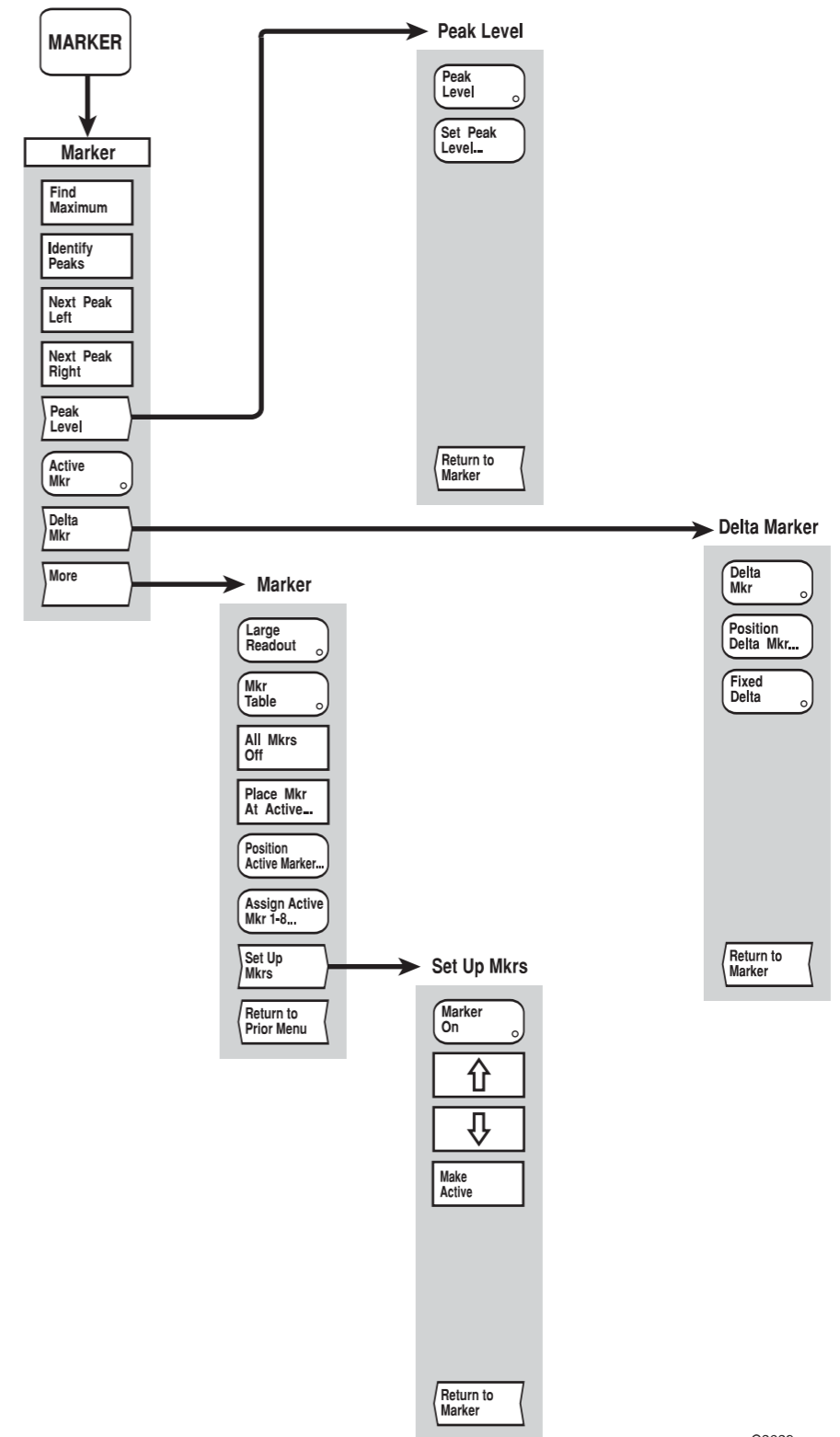

C3639

Fig. 3-33 MARKER menus - fault location channel

Fig, 3-33 MARKER menus - fault location channel

SETUP & ANALYSIS GROUP KEYS (Spectrum Analyzer Channel)

[SOURCE] key

The [SOURCE] key provides access to the Source menu shown in Fig. 3-34. Two source modes are available:

Tracking generator - the source tracks the frequency range of the spectrum analyzer receiver, or tracks with offset and scaling.

CW - continuous wave output at a user-defined frequency).

The output power may be adjusted for both modes.

A Source Only Mode is available in which the data acquisition system is turned off and the 6800A acts solely as a source. When in this mode, the various source settings are displayed, and all front panel keys, with the exception of the numeric keypad, units terminator keys and the [PRESET] key, will be locked out. Normal operation is restored by pressing the *[Exit Source Only Mode]* soft key on the Source menu or using the [PRESET] key.

SOURCE

Source
(CW selected)

During spectrum analyzer measurements, the 6800A source can be used either as a tracking generator, or set to a fixed frequency and power level. The Source menu functions apply to the currently active channel. The source is turned on or off by means of the [SOURCE ON/OFF] key. The source can also be frequency modulated.

The following indications are displayed in the RX information area:

- CW** indicates that the source is providing a continuous wave signal.
- TG** indicates that the source is being used as a tracking generator.
- OTG** indicates that the source is being used as a tracking generator, but its frequency is offset/scaled from the spectrum analyzer receiver frequency range.
- OTG?** indicates that the required tracking generator frequency range has been clipped so that it is within the range of the source. This would occur if the offset that is applied to the RX frequency is too large.

Tracking Generator

Enables the source to be used as a tracking generator, whose frequency range is set to the frequency range of the spectrum analyzer receiver.

Offset Tracking Gen

Enables the source to be used as a tracking generator, whose frequency range is scaled / offset from the spectrum analyzer receiver.

CW

Enables the source to be used as a continuous wave output at a user-defined frequency.

Set Output Power

Used to set the output power of the source.

Rotary Control	√	Step Keys	√	=Marker	×	Numeric Pad	√	Terminator	Any
----------------	---	-----------	---	---------	---	-------------	---	------------	------------

Set Frequency

Used to set the CW frequency of the source.

Rotary Control	√	Step Keys	√	=Marker	×	Numeric Pad	√	Terminator	10+
----------------	---	-----------	---	---------	---	-------------	---	------------	------------

FM

Leads to the FM menu, which enables source frequency modulation to be set up.
See page 3-136.

More

Leads to the second page of this menu.
See page 3-197..

SOURCE**More****Source**

This is a continuation of the previous menu.

Enter Source Only Mode

Puts the instrument into source only mode, in which the 6800A acts solely as a source. The source parameters are displayed, as shown in Fig. 3-24. All front panel keys, with the exception of the numeric keypad, units terminator keys and the [PRESET] key are locked out. The label for this soft key changes to *[Exit Source Only Mode]*.

or

Exit Source Only Mode

Returns the instrument to the measurement mode it was in before source only mode was entered. The label for this soft key is restored to *[Enter Source Only Mode]*.

Frequency Standard

Leads to the Freq Standard menu, which allows the frequency standard to be used by the synthesized source to be selected.
See page 3-141.

Voltage Output

Leads to the Voltage O/P menu, which enables the voltage output facility to be set up.
See page 3-142.

Return to Prior Menu

Returns to the first page of the Source menu.

SOURCE

Source
(Tracking Generator selected)

During spectrum analyzer measurements, the 6800A source can be used either as a tracking generator, or set to a fixed frequency and power level. The Source menu functions apply to the currently active channel. The Source is turned on or off by means of the [SOURCE ON/OFF] key.

Note When the tracking generator is enabled, the frequency limits of the receiver are restricted so that they are within the range of the source, unless frequency offset/scaling have been applied.

The following indications are displayed in the RX information area:

- CW** indicates that the source is providing a continuous wave signal.
- TG** indicates that the source is being used as a tracking generator.
- OTG** indicates that the source is being used as a tracking generator, but its frequency is offset/scaled from the spectrum analyzer receiver frequency range.
- OTG?** indicates that the required tracking generator frequency range has been clipped so that it is within the range of the source. This would occur if the offset that is applied to the RX frequency is too large.

Tracking Generator Enables the source to be used as a tracking generator, whose frequency range is set to the frequency range of the spectrum analyzer receiver.

Offset Tracking Gen Enables the source to be used as a tracking generator, whose frequency range is scaled / offset from the spectrum analyzer receiver.

CW Enables the source to be used as a continuous wave output at a user-defined frequency.

Set Output Power Used to set the output power of the source.

Rotary Control	√	Step Keys	√	=Marker	×	Numeric Pad	√	Terminator	Any
----------------	---	-----------	---	---------	---	-------------	---	------------	------------

More Leads to the second page of this menu.
See page 3-197..

SOURCE

Source
(Offset Tracking
Generator selected)

During spectrum analyzer measurements, the 6800A source can be used either as a tracking generator, or set to a fixed frequency and power level. The Source menu functions apply to the currently active channel. The Source is turned on or off by means of the [SOURCE ON/OFF] key.

Frequency offset and scaling functions are provided between the tracking generator frequency range and the spectrum analyzer receiver, in order to allow measurements of frequency translation devices. The order in which the offset and scaling are applied can be selected:

When the [Apply Scale then Offset] soft key is pressed::

$$f_{TG} = (f_{receiver} \times \text{scale factor}) + f_{offset}$$

When the [Apply Offset then Scale] soft key is pressed::

$$f_{TG} = (f_{receiver} + f_{offset}) \times \text{scale factor}$$

The default values are: scale factor = 1, $f_{offset} = 0$.

Note When the tracking generator is enabled, the frequency limits of the receiver are restricted so that they are within the range of the source, unless frequency offset/scaling have been applied.

The following indications are displayed in the RX information area:

- CW** indicates that the source is providing a continuous wave signal.
- TG** indicates that the source is being used as a tracking generator.
- OTG** indicates that the source is being used as a tracking generator, but its frequency is offset/scaled from the spectrum analyzer receiver frequency range.
- OTG?** indicates that the required tracking generator frequency range has been clipped so that it is within the range of the source. This would occur if the offset that is applied to the RX frequency is too large.

Tracking Generator Enables the source to be used as a tracking generator, whose frequency range is set to the frequency range of the spectrum analyzer receiver.

Offset Tracking Gen Enables the source to be used as a tracking generator, whose frequency range is scaled / offset from the spectrum analyzer receiver, using the menu accessed via the [Set Scale and Offset] soft key.

CW Enables the source to be used as a continuous wave output at a user-defined frequency.

Set Output Power Used to set the output power of the source.

Rotary Control	√	Step Keys	√	=Marker	×	Numeric Pad	√	Terminator	Any
----------------	---	-----------	---	---------	---	-------------	---	------------	-----

Apply Scale then Offset Multiplies the source frequency by the scale factor then adds the offset..

Apply Offset then Scale Adds the offset value to the source frequency then multiplies the result by the scale factor..

Set Scale and Offset Leads to the Scale and Offset menu, which allows the values of scale factor and offset to be set.
See page 3-200.

More Leads to the second page of this menu.
See page 3-197..

SOURCE **Set Scale and Offset**

Scale and Offset This menu is used to apply scaling/offset between the frequency range of the spectrum analyzer receiver and that of the tracking generator.

Set Frequency Scaling Frequency offset and scaling functions are provided from the spectrum analyzer receiver to the tracking generator frequency range, in order to allow measurements of frequency translation devices. The presence of an offset or scaling factor will be indicated on the screen. This soft key allows entry of a scaling factor.

Rotary Control	√	Step Keys	√	=Marker	×	Numeric Pad	√	Terminator	Any
----------------	---	-----------	---	---------	---	-------------	---	------------	------------

Set Frequency Offset Allows entry of an offset, that may be applied in addition to the scaling factor, to the receiver frequency range, in order to derive a tracking generator range.

Rotary Control	√	Step Keys	√	=Marker	×	Numeric Pad	√	Terminator	10+
----------------	---	-----------	---	---------	---	-------------	---	------------	------------

Return to Source Returns to the Source menu.

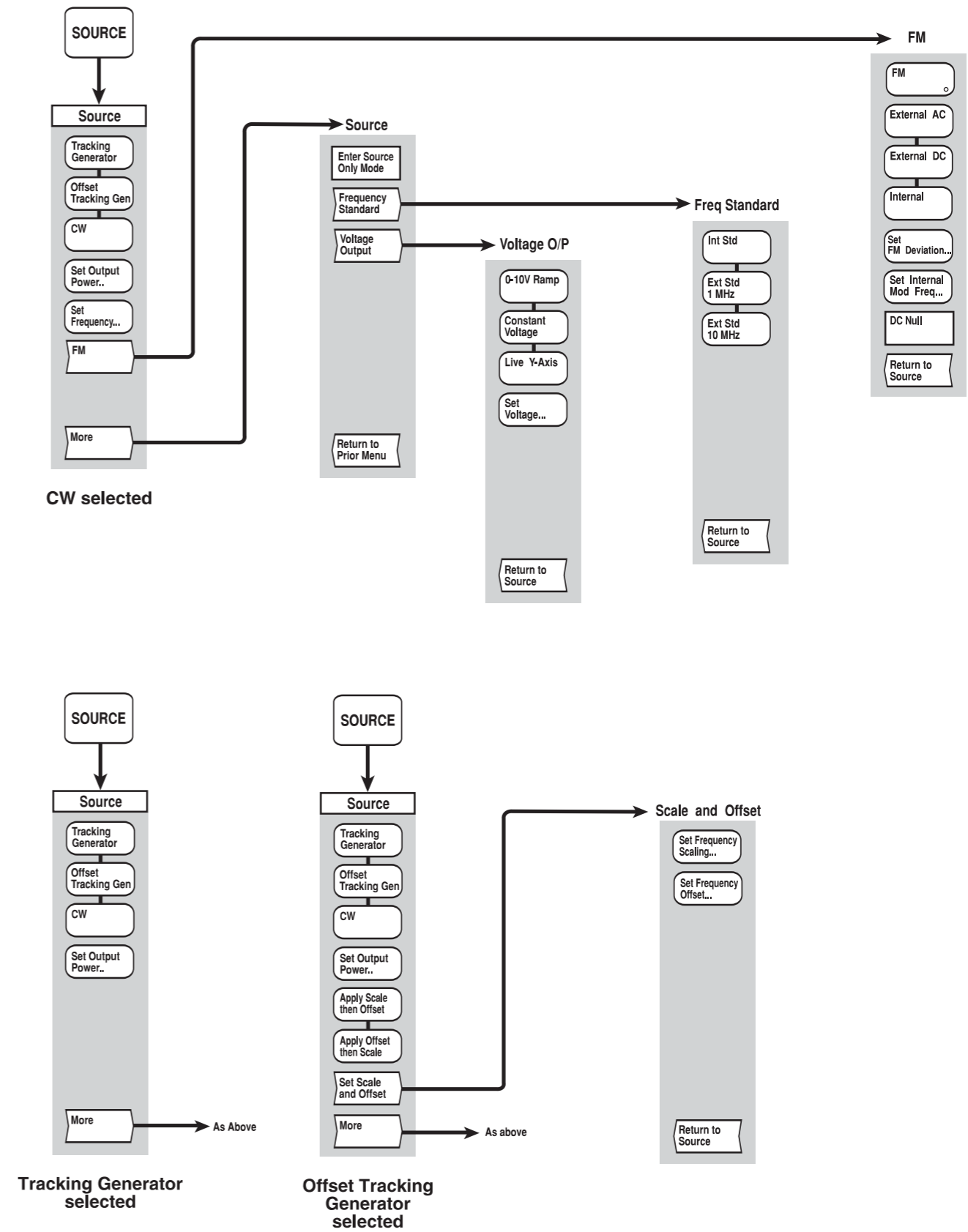

C4851

Fig, 3-34 SOURCE menus - spectrum analyzer channel

Fig, 3-34 SOURCE menus - spectrum analyzer channel

[CAL] key

The [CAL] key provides access to the calibration menu shown in Fig. 3-35. The only calibration that is required is normalising of the spectrum analyzer measurement when using the tracking generator.

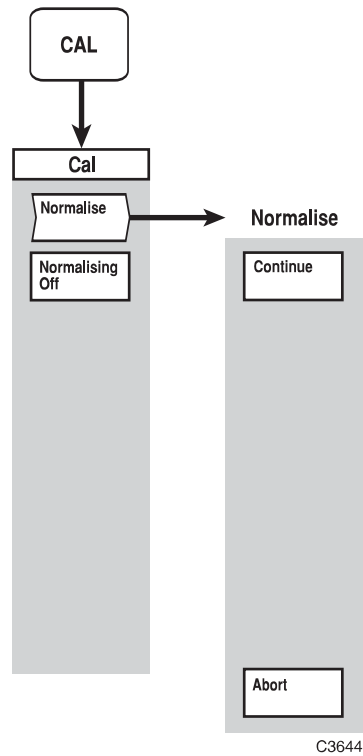

C3644

Fig. 3-35 CAL menus - spectrum analyzer channel

CAL

Cal **The normalise facility is used to compensate for frequency response errors due to connecting cables and test fixtures when measuring the response of frequency sensitive devices such as filters and amplifiers.**

Normalise Leads to the Normalise menu.
See page 3-204.

Normalising Off Turns off normalisation.

CAL

Normalise

Normalise ***See Fig. 35.* This function is used in conjunction with the tracking generator output to compensate for frequency response errors incurred by the spectrum analyzer test fixtures and cables. This permits the frequency response of the device under test to be displayed with all external errors removed.**

The user is prompted to connect the signal source output (i.e. tracking generator output) to the spectrum analyzer input and press 'Continue' when ready. The connection should be made using any test fixtures and connecting cables that are to be used in the measurement. The screen displays the frequency response of the test fixture and cables. The [*Continue*] soft key starts the normalisation process. The user is informed when data has been acquired (and saved to the normalisation store), and is being applied. The function then terminates, and returns to the Cal menu.

When the device under test is connected, the resulting response will be that for the device only, the effects of the extraneous circuitry being nullified. A normalised trace is indicated on the screen by **Nrm** in the trace information area (and also on the hard copy). The reference level is set to 0 dB.

Continue Starts the normalisation process.

Abort Normalisation Terminates the normalisation process and returns the user to the Cal menu.

[SCALE / FORMAT] key

The [SCALE / FORMAT] key enables the active measurement to be displayed in the required format, i.e. the units in which the response (vertical axis) is displayed. It also enables the vertical positioning and scaling to be adjusted.

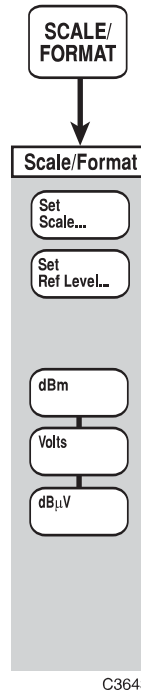

Fig. 3-36 SCALE/FORMAT menu - spectrum analyzer channel

SCALE / FORMAT

Scale / Format

This menu enables the user to select the measurement units, and to set the positioning and scaling for a trace.

The reference position is the position on the vertical axis that remains fixed during scaling. This is indicated on the screen by the Reference Position Indicator. The reference level is the value corresponding to the position of the Reference Position Indicator on the vertical scale, and is displayed in the relevant trace information area, together with the scaling factor.

The reference level and scaling values are displayed in the relevant trace information area. The vertical position of the trace can be adjusted by changing the reference level.

The default values for the reference level, scaling and reference position for each format are listed below:

Format	Reference Level	Scaling	Reference Position
dBm	0 dBm	10 dB / div	Top line
Volts	10 V	0.1 V / div	Top line
dB μ V	107 dB μ V	10 dB / div	Top line
kHz / MHz	0 kHz	2 kHz / div	Middle line

Note

The kHz/MHz format cannot be directly selected; it is applied by default when FM demodulation is applied and the demodulated waveform is then viewed.

Set Scale

Sets the scale for the currently active measurement.

dBm, dB μ V & kHz/MHz formats

Rotary Control	<input checked="" type="checkbox"/>	Step Keys	<input checked="" type="checkbox"/>	=Marker	<input type="checkbox"/>	Numeric Pad	<input type="checkbox"/>	Terminator	<input type="checkbox"/>
----------------	-------------------------------------	-----------	-------------------------------------	---------	--------------------------	-------------	--------------------------	------------	--------------------------

Volts format

For Volts format the scaling is set to 0.1 of the reference level (e.g. 1 V/div if the reference level is 10 V), and follows a 1, 2, 5... sequence if adjusted with the step keys.

Rotary Control	<input checked="" type="checkbox"/>	Step Keys	<input checked="" type="checkbox"/>	=Marker	<input type="checkbox"/>	Numeric Pad	<input checked="" type="checkbox"/>	Terminator	<input type="checkbox"/>	10⁻
----------------	-------------------------------------	-----------	-------------------------------------	---------	--------------------------	-------------	-------------------------------------	------------	--------------------------	-----------------------

Note The numeric pad cannot be used for the dBm, dB μ V and kHz/MHz formats as they are only settable in a 1, 2, 5... sequence.

**Set
Ref Level**

Sets the reference level for the active measurement (the reference level is also adjustable from the Spectrum menu).

dBm & dB μ V formats

Rotary Control	✓	Step Keys	✓	=Marker	✓	Numeric Pad	✓	Terminator	Any
----------------	---	-----------	---	---------	---	-------------	---	------------	------------

Volts format

Rotary Control	✓	Step Keys	✓	=Marker	✓	Numeric Pad	✓	Terminator	10-
----------------	---	-----------	---	---------	---	-------------	---	------------	------------

kHz/MHz format

Rotary Control	✓	Step Keys	✓	=Marker	✓	Numeric Pad	✓	Terminator	10+
----------------	---	-----------	---	---------	---	-------------	---	------------	------------

Note The kHz / MHz format is selected automatically when an FM demodulated waveform is displayed.

dBm

Selects dBm format.

This soft key will be unselectable if FM demodulation is being applied and the demodulated waveform is being viewed.

Volts

Selects Volts format. An impedance value of 50 Ω is assumed when converting a power level to a voltage reading, e.g. 0 dBm (1 mW) = 224 mV.

This soft key will be unselectable if FM demodulation is being applied and the demodulated waveform is being viewed.

dB μ V

Selects dB μ V format. An impedance value of 50 Ω is assumed when converting a power level to a voltage reading, e.g. 0 dBm (1 mW) = 224 mV = 107 dB μ V.

This soft key will be unselectable if FM demodulation is being applied and the demodulated waveform is being viewed.

[MARKER] key

Markers provide numerical readout of trace data and allows various types of measurement to be performed.

The Marker menus are shown in Fig. 3-37

MARKER

Marker	This menu provides facilities for setting up markers, and using them to perform various types of measurement.
Peak Search	Places the active marker at the x-axis position corresponding to the maximum response value. <i>Unselectable if the demodulated waveform is being viewed</i>
Mkr to Centre Freq	Uses the frequency position of the active marker to set the centre frequency of the spectrum analyzer receiver. <i>Unselectable if the demodulated waveform is being viewed</i>
Mkr to Ref Level	Uses the response value of the active marker to set the reference level. <i>Unselectable if the demodulated waveform is being viewed</i>
Peak Search Functions	Leads to the Peak Search Fns menu. <i>See page 3-211.</i> <i>Unselectable if the demodulated waveform is being viewed</i>
Mkr Functions	Leads to the Mkr Funcs menu, which enables various measurement functions to be carried out by means of the markers. <i>See page 3-212.</i> <i>Unselectable if the demodulated waveform is being viewed</i>
Active Mkr	Toggles the active marker on or off. Turning off the active marker also turns off the delta marker. Once the active marker is turned on it can be positioned anywhere along the trace, using the rotary control. To set the active marker to a specific domain value, using the numeric keypad, the <i>[Position Active Mkr]</i> soft key must be selected. If <i>[View Waveform]</i> has been enabled in the Demodulation menu (see page 3-123), turning on the active marker will also turn on the delta marker. This enables a readout of the period of the demodulated waveform to be obtained by measuring the difference in time between the active and delta markers.
Delta Mkr	Leads to the Delta Marker menu. <i>See page 3-211.</i>
More	Leads to the second page of the Marker menu. <i>See page 3-210.</i>

MARKER

More

Marker

This menu provides additional facilities for setting up markers.

Large Readout

Toggles large readout mode on or off. When on, the active marker spot reading is displayed in the Trace Information Area using large digits, so that it may be read at a distance. The large digit readout is only generated for the active measurement on the active channel.

This soft key will only be selectable if the active marker is turned on.

Mkr Table

Toggles display of the marker table on or off. The table is displayed below the graticule and shows the domain and response values for all markers currently displayed (apart from the delta marker) on the active channel. The absolute value of the responses is shown regardless of whether the delta marker is in use.

Unselectable if the demodulated waveform is being viewed

All Mkrs Off

Turns all of the markers off.

Unselectable if the demodulated waveform is being viewed

Place Mkr at Active

Used to place a marker at the active marker position by entering the required marker number.

Rotary Control	×	Step Keys	×	=Marker	×	Numeric Pad	√	Terminator	None
----------------	---	-----------	---	---------	---	-------------	---	------------	------

This soft key will only be selectable if the active marker is turned on and the demodulated waveform is not being displayed.

Position Active Mkr

Used to change the domain value (x-axis position) of the active marker, by entering a new value.

Rotary Control	√	Step Keys	√	=Marker	×	Numeric Pad	√	Terminator	10+
----------------	---	-----------	---	---------	---	-------------	---	------------	------------

This soft key will only be selectable if the active marker is turned on.

Assign Active Mkr 1-8

Used to select which is to be the active marker. The selection applies instrument wide.

Rotary Control	×	Step Keys	×	=Marker	×	Numeric Pad	√	Terminator	None
----------------	---	-----------	---	---------	---	-------------	---	------------	------

Unselectable if the demodulated waveform is being viewed

Set Up Mkrs

Leads to the Set Up Mkrs menu, which allows the user to activate and position selected markers. This is the same as for a scalar channel
See page 3-176.

Unselectable if the demodulated waveform is being viewed

Return to Prior Menu

Returns to the first page of the Marker menu.

MARKER

Peak Search Functions

Peak Search Fns This menu is used to locate the peaks of a trace.

Peak Search Places the active marker at the x-axis position corresponding to the maximum response value. (This performs the same function as the *[Peak Search]* soft key in the top level Marker menu.)

Next Peak Places the active marker at the next highest peak (either left or right) that is less than the current marker response value.

Peak Tracking Invokes the Find Peak Signal function once per measurement update.

Identify Peaks Finds the eight highest peaks, and identifies them with markers. The marker table is displayed, the active marker is placed at the highest peak on the active trace, and the remaining markers are placed at the next highest peaks.

Remove Mkr Table Removes the marker table and all markers from the display, apart from the active marker and delta marker (if displayed).

Return to Marker Returns to the Marker menu.

MARKER

Delta Mkr

Delta Marker This menu provides facilities for setting up the delta marker.

Delta Mkr Toggles the delta marker on or off. Turning on the delta marker also turns on the active marker.

Position Delta Mkr Used to change the domain value (x-axis position) of the delta marker, by entering a new value.

Rotary Control	√	Step Keys	√	=Marker	✕	Numeric Pad	√	Terminator	10+
----------------	---	-----------	---	---------	---	-------------	---	------------	-----

This soft key will only be selectable if the delta marker is turned on.

Fixed Delta When enabled, the spacing between the active and delta markers remains fixed when either is moved

Delta Mkr to Span Uses the difference between the frequency positions of the active and delta markers to set the span of the spectrum analyzer receiver.

This soft key will only be selectable if the delta marker is turned on.

Return to Marker Returns to the Marker menu.

MARKER

**Mkr
Functions**

Mkr Funcs

This menu is used for locating a response value on a trace, specified by the user, and provides a frequency counter facility. Noise measurements (in 1 Hz bandwidth) can also be made, and response values measured relative to the carrier.

Frequency Counter

Enables or disables the frequency counter. The frequency of a spectral line on the display can be measured by moving the active marker on the active channel to the frequency of interest. Note that this facility only works for frequencies up to 200 MHz, and for signals of sufficient amplitude to operate the counter.

This soft key will only be selectable if the active marker is turned on.

Counter Resolution

Allows the resolution of the frequency counter to be selected.

Rotary Control	√	Step Keys	√	=Marker	×	Numeric Pad	×	Terminator	None
----------------	---	-----------	---	---------	---	-------------	---	------------	------

This soft key will only be selectable if the active marker is turned on.

Noise In 1 Hz BW

The marker response of the displayed noise amplitude is corrected and normalized to a 1 Hz noise power bandwidth. The suffix (**1Hz**) is displayed after the readout to indicate that the function is enabled.

This soft key will only be selectable if the measurement is in Log format.

Measure Rel to Carrier

When this function is activated, the reading at the current position of the active marker is set to 0 dB (the carrier, for example), and subsequent spectrum analyzer measurements are made relative to this reading.

This soft key will only be selectable if the active marker is turned on.

Search Left

Causes the system to search left from the active marker position, in order to find the response value specified using the [Set Search Value] soft key. The active marker will be placed at this position. If two adjacent measurement points encompass the search value, the active marker will be placed at the measurement point which is nearer to the search value. If the search value is not found, a message will be displayed indicating this, and the active marker will remain where it is.

Search Right

As above, but the search direction is right.

Set Search Value

Sets the value that will be searched for. If the delta marker is off, this will be treated as an absolute response value. If the delta marker is on, however, it will be treated as a value relative to the response at the delta marker.

dBm format

Rotary Control	√	Step Keys	√	=Marker	√	Numeric Pad	√	Terminator	Any
----------------	---	-----------	---	---------	---	-------------	---	------------	------------

Volts format

Rotary Control	√	Step Keys	√	=Marker	√	Numeric Pad	√	Terminator	10-
----------------	---	-----------	---	---------	---	-------------	---	------------	------------

Return to Marker

Returns to the Marker menu.

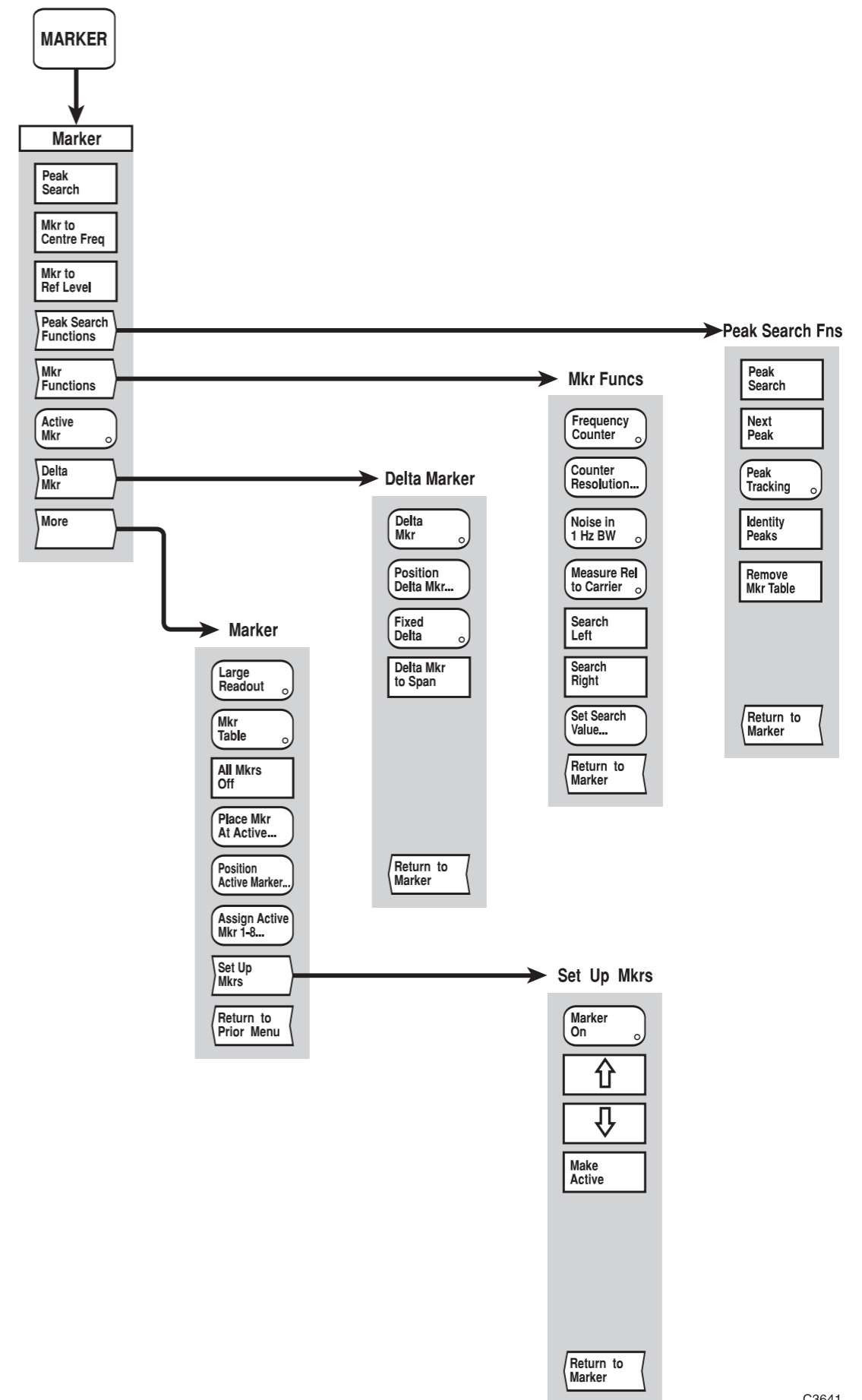

C3641

Fig. 3-37 MARKER menus - spectrum analyzer channel

Fig. 3-37 MARKER menus - spectrum analyzer channel

SETUP & ANALYSIS GROUP KEYS (Common)

[PRINT] key

The [PRINT] key provides access to the menus shown in Fig. 3-38, which enable hard copy output to be obtained using a suitable USB or parallel printer. The system allows further measurements to be made while printing is in progress.

The hard copy device can be connected to a front-panel USB port or the parallel (Centronics) port, as appropriate.

PRINT

- Print** **The Print menu enables printing of measurements.**
- Print** Initiates output of graphics information to the selected printer. A confirmation form will be displayed that will allow the number of copies to be set, the printer to be changed or to create a print file (see page 3-223).
The information that is printed is determined by the selection made using the function accessed via the *[Print Options]* soft key.
- Print Options** Leads to the Print Options menu, which allows the user to determine which information is output to the printer.
See page 3-217.
- Print Traces Only** Initiates printing of only the currently displayed traces(s), without any attributes. Using this soft key it is not necessary to go to the Print Options menu to turn off all the other hard copy elements. A confirmation form will be displayed that will allow the number of copies to be set and the printer to be changed (see page 3-223).
- Print File** Leads to the Print File menu, which allows a print file to be selected from the removable storage and then output to the current printer.
See page 3-221.
- Select Printer** Leads to the Select Printer menu, which allows the user to select which printer is connected to the instrument and which port it is connected to.
See page 3-222.
- Screen Dump** Performs a screen dump of the entire display and writes the data to a '.BMP' file (for embedding in a document, for example). Note that this is not the same as saving a measurement and it cannot be redisplayed on the screen. The name of the file will be prompted for, and the destination can be specified (internal store or removable storage). Pressing the *[OK]* soft key exits the screen dump menu. The display can then be set up as required; the next time the *[PRINT]* key is pressed the screen dump will be performed.
- Abort Print** Terminates output of information to the device being used.

PRINT

Print
OptionsPrint Options

This menu is used to specify which of the elements of the display are to be sent to the printer.

A form is displayed on the screen showing a list of the elements and their current state. The elements are:

Graticules	Specifies printing of graticules.										
Measurements	Specifies printing of measurements traces.										
Limit lines	Specifies printing of limit lines and the pass/fail indication.										
Screen title	Specifies printing of the screen title. The screen title applies to the whole display, and appears at the top of the screen. Screen titles can be entered and switched on or off by using the Titles menu ([UTILITY]/Titles).										
Measurement titles	Specifies printing of measurement titles. A channel may display up to two measurement titles, one for each trace. Measurement titles can be entered and switched on or off by using the Titles menu ([UTILITY]/Titles). A measurement title will be displayed only when both it and the corresponding trace are switched on.										
Markers	Specifies printing of markers, and also the active marker position and response.										
Graticule annotation	Specifies printing of the graticule annotation (the domain values at the bottom of the display), and also the reference position indicators.										
Measurement annotation	Specifies printing of measurement annotation: <table> <tr> <td><i>Measurement definition</i></td> <td><i>Reference level</i></td> </tr> <tr> <td><i>Averaging on/off indication</i></td> <td><i>Scaling</i></td> </tr> <tr> <td><i>Averaging number</i></td> <td><i>Path calibration</i></td> </tr> <tr> <td><i>Offset applied indication</i></td> <td><i>Memory operation</i></td> </tr> <tr> <td><i>Smoothing applied indication</i></td> <td></td> </tr> </table>	<i>Measurement definition</i>	<i>Reference level</i>	<i>Averaging on/off indication</i>	<i>Scaling</i>	<i>Averaging number</i>	<i>Path calibration</i>	<i>Offset applied indication</i>	<i>Memory operation</i>	<i>Smoothing applied indication</i>	
<i>Measurement definition</i>	<i>Reference level</i>										
<i>Averaging on/off indication</i>	<i>Scaling</i>										
<i>Averaging number</i>	<i>Path calibration</i>										
<i>Offset applied indication</i>	<i>Memory operation</i>										
<i>Smoothing applied indication</i>											
Marker table	Specifies printing of the table of displayed marker domain positions and responses.										
Measurement specific information	Specifies printing of CW frequency on scalar power sweeps and results of bandwidth measurements, for example.										
Date & time	Specifies printing of the date and time.										
Instrument type no	Specifies printing of the instrument type number.										
Manufacturer's identity	Specifies printing of the manufacturer's name.										
User text	Specifies printing of arbitrary text entered by the user. The text is shown at the bottom of the form										

With the exception of the marker table, all the above elements are turned on by default.

The graphical data available for printing depends on what is being displayed on the screen at the time the print command is received. The appearance of the print will resemble that of the screen display with the addition of information to identify traces and their corresponding limit lines and measurement titles so that a monochrome print (or photocopy) may be easily interpreted. Also, text in the trace information area on the display will appear to the right of the graticule on the hard copy.

On/Off

Toggles the selected element on or off.



Selects the previous entry in the list of elements.

This soft key will be unselectable if the highlight is at the beginning of the list.



Selects the next entry in the list of elements.

This soft key will be unselectable if the highlight is at the end of the list.

**Enter
User Text**

Enables descriptive text about the measurements to be entered.

**Save
Options**

Leads to the Save Options menu.
See page 3-219.

**Recall
Options**

Leads to the Recall Options menu.
See page 3-220.

**Return to
Print**

Returns to the Print menu.

PRINT

Print
OptionsSave
Options**Save Options**

This menu is used to save the current print options to a store specified by the user, or to a file on removable storage.

A form is displayed listing the identities of the available print options stores. To save the data to a specific store, the store name is selected from the list. Alternatively, a new store can be created by entering a new name in the appropriate entry field.

As well as the store id, its associated date and time stamp are also displayed in the list. A section at the bottom of the form will display the descriptive text for the currently selected store in the list and state whether or not it is password protected.

The print options can also be saved to a removable storage as an MS-DOS file. The removable storage is accessed by using the *[USB Memory]* soft key.

Save

Saves the current print options into the selected store.



Selects the previous entry in the list of stores. The list automatically scrolls, if necessary, when the highlight reaches the top of the list.

This soft key will be unselectable if the highlight is at the beginning of the list.



Selects the next entry in the list of stores. The list automatically scrolls, if necessary, when the highlight reaches the bottom of the list.

This soft key will be unselectable if the highlight is at the end of the list.

**New Store
Name**

Enables a new store name to be entered using text entry.

**USB
Memory**

When selected the list of print options stores shown will be those found in the current directory on the removable storage currently inserted in the USB port. As well as the list of settings stores any directories found in the current directory will also be shown. The [ENTER / =MKR] key is used to change directory.

Note

Access to the removable storage is global to the instrument and the state is preserved across visits to all menus that can access the USB ports.

**Set Store
Information**

Leads to the Set Store Info menu. This menu provides the same functions as the Set Store Info menu for trace memory stores.

See page 3-230.

**Return to
Print Options**

Returns to the Print Options menu.

PRINT

**Print
Options**

**Recall
Options**

Recall Options

This menu is used to recall a print options store. The print options will be set up according to the stored parameters.

A form is displayed listing the identities of the available stores. To retrieve the data from a specific store, it is selected from the list.

As well as the store id, its associated date and time stamp are also displayed in the list. A section at the bottom of the form will display the descriptive text for the currently selected store in the list and state whether or not it is password protected.

The print options store can also be retrieved from removable storage, which is accessed by pressing the *[USB Memory]* soft key.

Select

Retrieves the print options from the selected store.



Selects the previous entry in the list of stores. The list automatically scrolls, if necessary, when the highlight reaches the top of the list.

This soft key will be unselectable if the highlight is at the beginning of the list.



Selects the next entry in the list of stores. The list automatically scrolls, if necessary, when the highlight reaches the bottom of the list.

This soft key will be unselectable if the highlight is at the end of the list.

**USB
Memory**

When selected the list of print options stores shown will be those found in the current directory on the removable storage currently inserted in the USB port. As well as the list of stores any directories found in the current directory will also be shown. The [ENTER / =MKR] key is used to change directory.

Note Access to the removable storage is global to the instrument and the state is preserved across visits to all menus that can access the USB ports.

**Return to
Print Options**

Returns to the Print Options menu.

PRINT

Print
File**Print File**

This function allows a file containing hard copy output to be selected from the removable storage and then printed on the current printer. A print file is created by selecting the appropriate option when [Print] is pressed.

As well as the list of print files, any directories found in the current directory will also be shown. The [ENTER / =MKR] key is used to change directory.

Note Ensure that the print file is compatible with the current printer.

Select

Sends the file to the currently selected printer. A confirmation form will be displayed that will allow the number of copies to be set, the printer to be changed, and allow the print output to be sent to a file (see page 3-223).

↑

Selects the previous entry in the list of print files. The list automatically scrolls, if necessary, when the highlight reaches the top of the list.

This soft key will be unselectable if the highlight is at the beginning of the list/

↓

Selects the next entry in the list of print files. The list automatically scrolls, if necessary, when the highlight reaches the bottom of the list.

This soft key will be unselectable if the highlight is at the end of the list/

**USB
Memory**

When selected the list of print options shown will be those found in the current directory on the removable storage currently inserted in the USB port. As well as the list of stores any directories found in the current directory will also be shown. The [ENTER / =MKR] key is used to change directory.

Note Access to the removable storage is global to the instrument and the state is preserved across visits to all menus that can access the USB ports.

**Return to
Print**

Returns to the Print menu.

PRINT

**Select
Printer**

Select Printer

This function is used to set up the printer drivers installed in the instrument.

A form is displayed that shows the currently selected printer driver and the port that the printer is attached to. Below that a list of the currently installed printer drivers is displayed.

Select

Makes the currently highlighted device driver the one that will be used by the instrument. The port that the printer is connected to will be defaulted according to information contained within the device driver for the printer.

The displayed printer name includes the interface type; USB or parallel.

This key will be unselectable if no printer drivers have been installed.

↑

Selects the previous entry in the list of devices. The list automatically scrolls, if necessary, when the highlight reaches the top of the list.

This soft key will be unselectable if the highlight is at the beginning of the list.

↓

Selects the next entry in the list of devices. The list automatically scrolls, if necessary, when the highlight reaches the bottom of the list.

This soft key will be unselectable if the highlight is at the end of the list.

**Return to
Print**

Returns control to the Print menu.

Note If this menu was accessed from the Confirm Print menu then this key will be labelled [*Return to Confirm Print*].

PRINT	Print	
PRINT	Print Traces Only	
PRINT	Print File	Print
SCALAR	Limit Checking	Print Spec
SAVE / RECALL	View Inst Settings	Print

Confirm Print

This menu is used for the following :

- Select the number of copies to be printed
- Select whether the output will be directed to a file on the removable storage
- Change the printer being used
- Confirm that the output can start.

A form is displayed showing the current printer, the port it is attached to and the number of copies that will be printed.

OK

Starts the hardcopy output to the currently selected printer.

If [*Print to File*] has been selected then the Print to File sub-menu is displayed which allows the file name to be entered and the destination to be specified (internal memory or removable storage).

Print to File

Redirects the output to a file in internal memory or removable storage.

Copies

Allows the number of copies to be printed to be set.

Rotary Control	X	Step Keys	X	=Marker	X	Numeric Pad	√	Terminator	Any
----------------	---	-----------	---	---------	---	-------------	---	------------	-----

This soft key will be unselectable if the output is being directed to a file or the port is currently set to GPIB.

Select Printer

Leads to the Select Printer menu, which allows the user to select which printer is connected to the instrument, and which port it is connected to.

See page 3-222.

Cancel

Cancels the hard copy output and Returns to the Print menu.

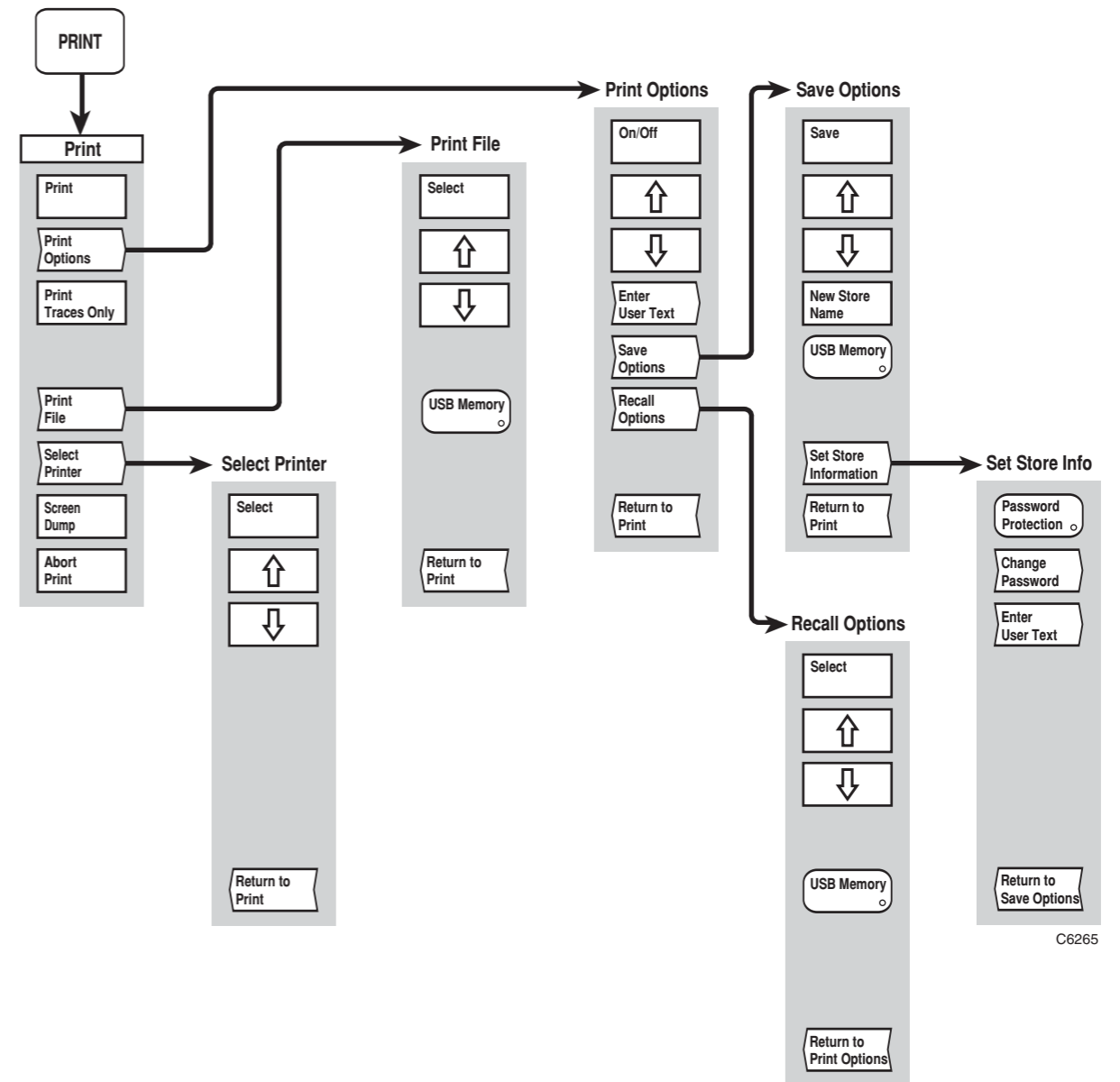

C6265

Fig. 3-38 PRINT menus

Fig. 3-38 PRINT menus

[SAVE / RECALL] key

The [SAVE/RECALL] key provides access to the menus shown in Figs. 3-39 and 3-40, which enables the current instrument settings or measurement traces to be saved to or recalled from a memory location specified by the user. Instrument settings and measurement traces can also be saved to or recalled from removable storage as MS-DOS files.

SAVE/RECALL

Save/Recall

See Fig. 3-39. The Save/Recall menu enables instrument settings and measurement traces to be saved, and then recalled for use in subsequent measurements.

The current instrument settings can be stored in a specified memory location in the 6800A internal non-volatile memory or on removable storage. Any of the stores can later be recalled in order to re-create the instrument state defined by the store contents. Facilities are available for viewing the stores without recalling them, and for obtaining a hard copy printout of the currently displayed store contents.

Measurement traces can be similarly stored, and subsequently recalled and/or used in relative measurements.

Measurement traces can also be saved as spreadsheet format (CSV) files.

Save Trace

Leads to the Save Trace menu, which enables a measurement trace to be saved to an internal 6800A store or as a file on removable storage.

See page 3-229.

Only selectable if the active measurement is not a memory.

Recall Trace

Leads to the Recall Trace menu, which enables saved measurement traces to be displayed.

See page 3-231.

Apply Trace Memory

Leads to the Apply Trace Mem menu.

See page 3-232.

This soft key will only be selectable for a scalar channel, and if the currently defined trace is not a memory.

Resume Live Measurement

Returns the active measurement to live input from the receiver for a spectrum analyzer channel, or the defined measurement for a fault location channel.

Only selectable if the current active channel is a spectrum or fault location channel and the current active measurement is a trace memory

Save Settings

Leads to the Save Settings menu, which enables the current instrument settings to be saved to an internal 6800A store or as a file on removable storage.

See page 3-233

Recall Settings

Leads to the Recall Settings menu, which enables saved instrument settings to be recalled.

See page 3-234

Save Settings as User Default

Causes the current instrument settings to be saved to the user default settings store, after confirmation from the user.

View Inst Settings

Leads to the View Settings menu, and enables the current, default and user default settings, plus the contents of instrument settings stores, to be displayed.

See page 3-235.

SAVE/RECALL

Save
Trace**Save Trace**

See Fig. 3-39. This function is used to save the currently active measurement to a memory location specified by the user, or to a file on removable storage.

A form is displayed listing the identities of the available memory stores. To save the data to a specific memory store, the memory name is selected from the list. Alternatively, a new memory store can be created by entering a new name in the appropriate entry field. As well as the store id, its associated date and time stamp are also displayed in the list. A section at the bottom of the form will display the descriptive text for the currently selected store in the list and state whether or not it is password protected.

The measurement can also be saved to removable storage as an MS-DOS file. The removable storage is accessed by using the [USB Memory] soft key.

Some of the instrument settings are also saved with the measurement. These settings are required in order that the instrument can re-create the channel and measurement set-up necessary to display the memory as it was originally stored.

Save

Saves the current active measurement into the selected memory store.

↑

Selects the previous entry in the list of memories. The list automatically scrolls, if necessary, when the highlight reaches the top of the list.

This soft key will be unselectable if the highlight is at the beginning of the list.

↓

Selects the next entry in the list of memories. The list automatically scrolls, if necessary, when the highlight reaches the bottom of the list.

This soft key will be unselectable if the highlight is at the end of the list.

**New Store
Name**

Enables a new memory store name to be entered.

**USB
Memory**

When selected the list of memory stores shown will be those found in the current directory on the removable storage currently inserted in the USB port. As well as the list of memory stores any directories found in the current directory will also be shown. The [ENTER / =MKR] key is used to change directory.

Note Access to the removable storage is global to the instrument and the state is preserved across visits to all menus that can access the USB ports.

**Spreadsheet
Format**

When this soft key is selected the list of memory stores shown will be those that are in the spreadsheet (CSV) format. If the current active measurement is saved into a new store then it will be saved in the spreadsheet format, i.e. in a form suitable for use in spreadsheet programs.

When measurements are saved in spreadsheet format, a binary version of the file is stored at the same time so that the data can be transferred back into the instrument if required..

**Set Store
Information**

Leads to the Set Store Info menu. This menu provides the same functions as the Set Store Info menu for trace memory stores

See page 3-230

**Return to
Save/Recall**

Returns to the Save/Recall menu.

SAVE/RECALL	Save Trace	Set Store Information
SAVE/RECALL	Save Settings	Set Store Information

Set Store Info *See Fig. 3-39. This menu is used to enable / disable password protection for the selected store and to enter arbitrary text to be saved with the store.*

A form is displayed showing information about the store, including whether or not it is password protected, whether or not it is in the spreadsheet format and the descriptive text.

Password Protection Toggles password protection on / off for the store. If the protection is being turned on a password will be prompted for. If protection is being turned off, the currently set password will be required. Note that this feature protects the selected store from being overwritten, not from unauthorised access (such as recalling a measurement trace).

Change Password This enables the currently set password to be changed. The current password will have to be given before the new password can be entered. Once the new password has been entered it will be prompted for again as confirmation.

This soft key will be unselectable if password protection is turned off.

Enter User Text This enables descriptive text about the store to be entered.

Return to Save Trace Returns to the Save Trace menu.

SAVE/RECALL

Recall
Trace**Recall Trace**

See Fig. 3-39. This function enables a saved measurement trace to be displayed.

A form is displayed listing the identities of the available memory stores. To retrieve the data from a specific memory location, it is selected from the list.

As well as the store id, its associated date and time stamp are also displayed in the list. A section at the bottom of the form will display the descriptive text for the currently selected store in the list and state whether or not it is password protected

The measurement can also be retrieved from removable storage, which is accessed by pressing the [USB Memory] soft key.

The recalled trace will be removed when a live input is defined for the measurement (e.g. by pressing [SCALAR] [Input Selection] [A]).

Various instrument settings are saved together with the trace memory. When the trace is recalled, these saved settings may affect other measurements that are being displayed. The choice is therefore given of using either the saved settings or current settings.

Select

Retrieves the data from the selected store.



Selects the previous entry in the list of memories. The list automatically scrolls, if necessary, when the highlight reaches the top of the list.

This soft key will be unselectable if the highlight is at the beginning of the list.



Selects the next entry in the list of memories. The list automatically scrolls, if necessary, when the highlight reaches the bottom of the list.

This soft key will be unselectable if the highlight is at the end of the list.

**USB
Memory**

When selected, the list of memory stores shown will be those found in the current directory on the removable storage currently inserted in the USB port. As well as the list of memory stores any directories found in the current directory will also be shown. The [ENTER / =MKR] key is used to change directory.

Note Access to the removable storage is global to the instrument and the state is preserved across visits to all menus that can access the USB ports.

**Return to
Save/Recall**

Returns to the Save/Recall menu.

SAVE/RECALL

**Apply Trace
Memory**

Apply Trace Mem *See Fig. 3-39.* Enables the currently active measurement to be made relative to the measurement data in a specified trace memory which can be located in a 6800A store or on removable storage. The measurement that is displayed is the ratio of the live trace to the stored trace.

For normal measurements, the domain range will be the same for both current and stored traces. Memory data will be interpolated to match a live measurement over a different start/stop range.

The memory operation applies per trace.

**Relative to
Memory**

Leads to the Rel to Memory menu, which enables selection of the measurement trace that is to be used in the relative measurement. This provides the same functions as the Recall Trace menu (page 3-231), except that the selected measurement trace will be used in the relative measurement, instead of being displayed.

**Memory
Operation Off**

Turns off the memory operation.

**Return to
Save/Recall**

Returns to the Save/Recall menu.

SAVE/RECALL

Save
Settings**Save Settings**

See Fig. 3-39. This function is used to save the current instrument settings to a memory location specified by the user, or to a file on removable storage.

A form is displayed listing the identities of the available settings stores. To save the data to a specific settings store, the store name is selected from the list. Alternatively, a new settings store can be created by entering a new name in the appropriate entry field.

As well as the store id, its associated date and time stamp are also displayed in the list. A section at the bottom of the form will display the descriptive text for the currently selected store in the list and state whether or not it is password protected.

The settings can also be saved to removable storage as an MS-DOS file. The removable storage is accessed by using the [USB Memory] soft key.

Save

Saves the current instrument settings into the selected store.

↑

Selects the previous entry in the list of settings stores. The list automatically scrolls, if necessary, when the highlight reaches the top of the list.

This soft key will be unselectable if the highlight is at the beginning of the list.

↓

Selects the next entry in the list of settings stores. The list automatically scrolls, if necessary, when the highlight reaches the bottom of the list.

This soft key will be unselectable if the highlight is at the end of the list.

**New Store
Name**

Enables a new settings store name to be entered.

**USB
Memory**

When selected the list of settings stores shown will be those found in the current directory on the removable storage currently inserted in the USB port. As well as the list of settings stores any directories found in the current directory will also be shown. The [ENTER / =MKR] key is used to change directory.

Note Access to the removable storage is global to the instrument and the state is preserved across visits to all menus that can access the USB ports.

**Set Store
Information**

Leads to the Set Store Info menu. This menu provides the same functions as the Set Store Info menu for trace memory stores.
See page 3-230.

**Return to
Save/Recall**

Returns to the Save/Recall menu.

SAVE/RECALL

**Recall
Settings**

Recall Settings

See Fig. 3-39. This function is used to recall an instrument settings store. The instrument will be set up according to the stored parameters.

A form is displayed listing the identities of the available settings stores. To retrieve the data from a specific store, it is selected from the list.

As well as the store id, its associated date and time stamp are also displayed in the list. A section at the bottom of the form will display the descriptive text for the currently selected store in the list and state whether or not it is password protected.

The settings store can also be retrieved from removable storage, which is accessed by pressing the *[USB Memory]* soft key.

Select

Retrieves the instrument settings from the selected store.



Selects the previous entry in the list of settings stores. The list automatically scrolls, if necessary, when the highlight reaches the top of the list.

This soft key will be unselectable if the highlight is at the beginning of the list.



Selects the next entry in the list of settings stores. The list automatically scrolls, if necessary, when the highlight reaches the bottom of the list.

This soft key will be unselectable if the highlight is at the end of the list.

**USB
Memory**

When selected the list of settings stores shown will be those found in the current directory on the removable storage currently inserted in the USB port. As well as the list of settings stores any directories found in the current directory will also be shown. The [ENTER / =MKR] key is used to change directory.

Note Access to the removable storage is global to the instrument and the state is preserved across visits to all menus that can access the USB ports.

**Return to
Save/Recall**

Returns to the Save/Recall menu.

SAVE/RECALL

View Inst
Settings**View Settings**

See Fig. 3-40. This function is used to view the instrument's current, preset default and user preset default settings, plus the contents of the settings stores.

A form is displayed on the screen showing the selected settings. The *[Print]* soft key is used to output the settings to the current printer. Depending upon which type of settings are being viewed, additional functions will be available via soft keys that appear on the menu.

**Current
Settings**

Selects the current settings as those to be viewed.

**Default
Settings**

Selects the preset default settings as those to be viewed.

**User Default
Settings**

Selects the contents of the user preset default settings store to be viewed.

**Settings
Store**

Allows the contents of a selected settings store to be viewed.

If no store has been selected then all parameters will be shown as blank until a store is selected.

The functions of the next two soft keys depends on which settings have been selected. The soft keys are not present if 'Default Settings' or 'User Default Settings' are selected.

Current Settings selected**Save to
Store**

Leads to the Save Settings menu, which enables the current settings to be saved to a selected store.
See page 3-233.

**Save Settings
as User Default**

Causes the current instrument settings to be saved to the user default setting store, after confirmation from the user.

Settings Store selected**Select
Store**

Leads to the Select Store menu, which enables the settings store to be viewed to be selected.
See page 3-236.

**Recall from
Store**

Applies the instrument settings from the store currently being viewed.
This soft key will be unselectable if no store has been selected.

Print

Causes the currently displayed information to be sent to the printer. Leads to the Confirm Print menu.
See page 3-223

This soft key will be unselectable if a settings store is being viewed but no store has been selected.

**Return to
Save/Recall**

Returns to the Save/Recall menu.

SAVE/RECALL

**View Inst
Settings**

**Select
Store**

Select Store

See Fig. 3-40. This menu is used to select an instrument settings store to be viewed.

A form is displayed listing the identities of the available settings stores. To view the data in a specific settings store, the store name is selected from the list.

As well as the store id, its associated date and time stamp are also displayed in the list. A section at the bottom of the form will display the descriptive text for the currently selected store in the list and state whether or not it is password protected.

The settings stores can also be on removable storage as MS-DOS files. The removable storage is accessed by using the [USB Memory] soft key.

Select

Retrieves the data from the selected store.



Selects the previous entry in the list of settings stores. The list automatically scrolls, if necessary, when the highlight reaches the top of the list.

This soft key will be unselectable if the highlight is at the beginning of the list.



Selects the next entry in the list of settings stores. The list automatically scrolls, if necessary, when the highlight reaches the bottom of the list.

This soft key will be unselectable if the highlight is at the end of the list.

**USB
Memory**

When selected the list of settings stores shown will be those found in the current directory on the removable storage currently inserted in the USB port. As well as the list of settings stores any directories found in the current directory will also be shown. The [ENTER / =MKR] key is used to change directory.

Note Access to the removable storage is global to the instrument and the state is preserved across visits to all menus that can access the USB ports.

**Return to
View Settings**

Returns to the View Instrument Settings menu.

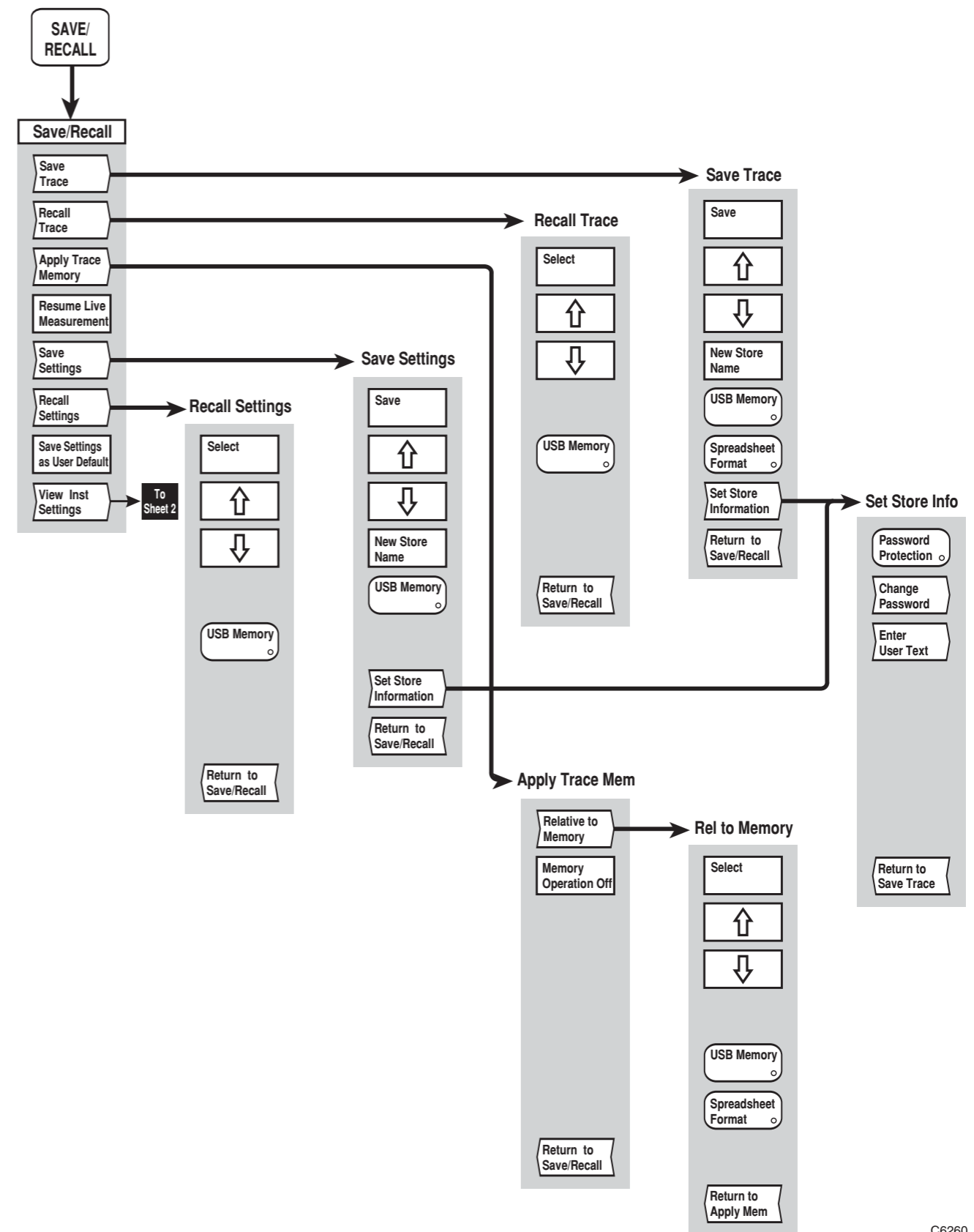

C6260

Fig. 3-39 SAVE/RECALL menus (sheet 1)

Fig. 3-39 SAVE/RECALL menus (sheet 1)

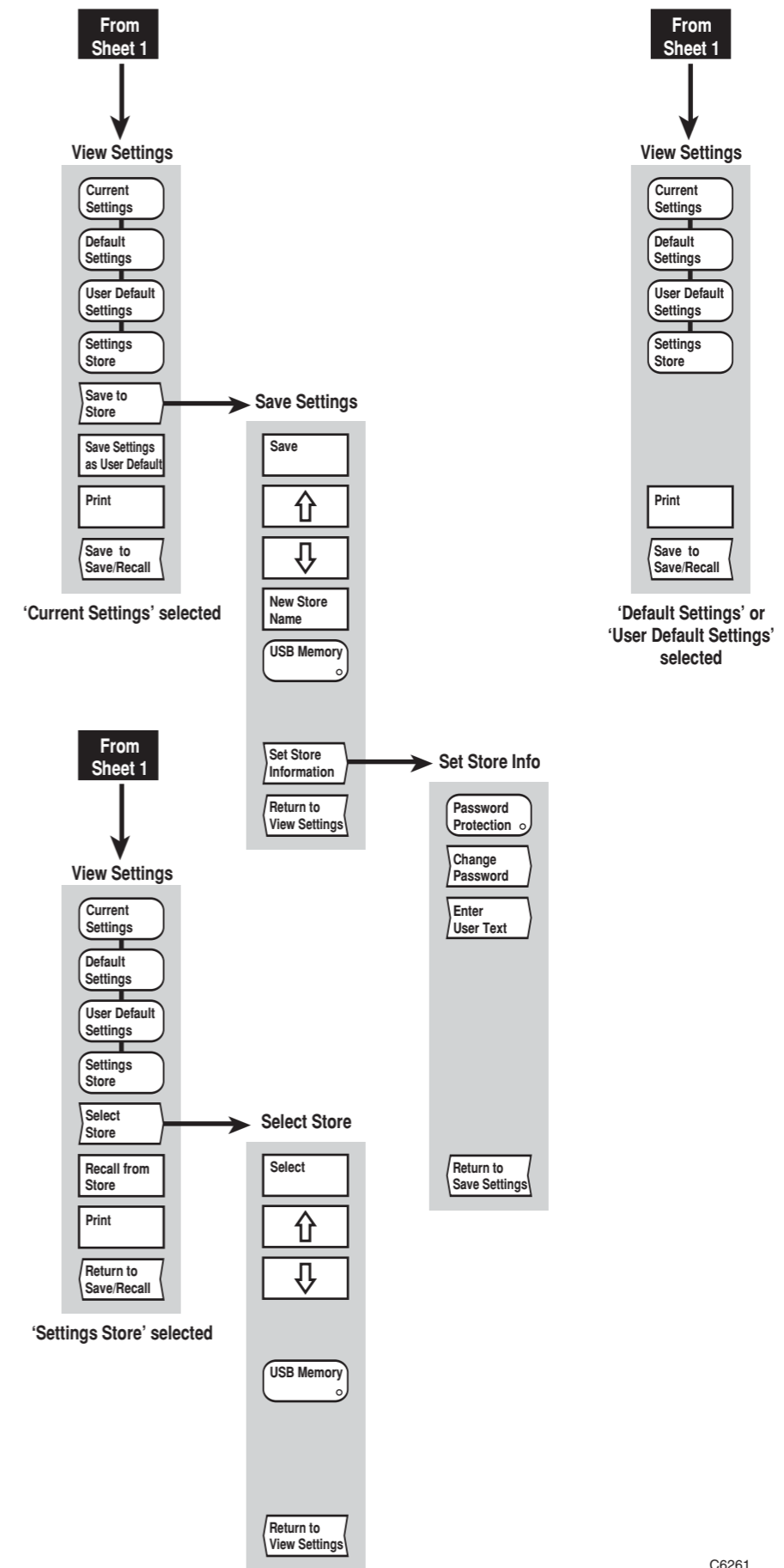

C6261

Fig. 3-40 SAVE/RECALL menus (sheet 2)

Fig. 3-40 SAVE/RECALL menus (sheet 2)

SYSTEM GROUP KEYS

[RUN APPS] key

If no application is loaded and running then the [RUN APPS] key selects the menu from which Applications can be run, otherwise it will return the operator to the initial screen of the currently loaded application.

Applications are installed, removed and made 'auto-runnable' using [Applications] under the Utility menu. See page 3-266.

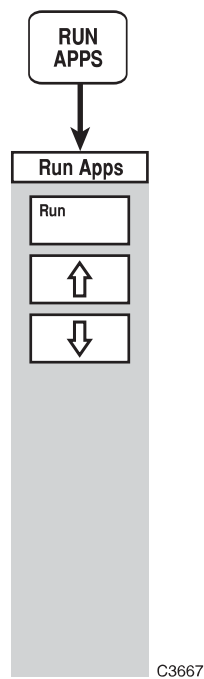

Fig. 3-41 RUN APPS menu

RUN APPS

Run Apps

This menu is used to select an application to be loaded and run.

A form is displayed listing the identities of the available applications. To run the application, the application name is selected from the list.

Run

Runs the selected application. Some applications may require the user to select a language before it is run.



Selects the previous entry in the list of applications. The list automatically scrolls, if necessary, when the highlight reaches the top of the list.

This soft key will be unselectable if the highlight is at the beginning of the list



Selects the next entry in the list of applications. The list automatically scrolls, if necessary, when the highlight reaches the bottom of the list.

This soft key will be unselectable if the highlight is at the end of the list

[UTILITY] key

The [UTILITY] key provides access to the series of menus illustrated in Figs. 3-42 to 3-46. The menus provide utility functions, such as generating titles, setting up the display, and performing various system functions.

UTILITY

Utility	<i>See Fig. 3-42. All the soft keys in this menu lead to further menus which provide utility functions not directly concerned with the measurement.</i>
Remote Control	Leads to the Remote menu, which enables the instrument to be set up for remote operation. <i>See page 3-244.</i>
Titles	Leads to the Titles menu, which enables the main screen title and measurement titles to be entered and displayed. <i>See page 3-245.</i>
Security	Leads to the Security menu, which give access to the security functions, such as setting the two user passwords. <i>See page 3-246.</i>
Set Inc / Dec Steps	Leads to the Inc/Dec Steps menu, which enables the user to define the step size that is used when changing numeric parameters with the step keys and rotary control. <i>See page 3-247.</i>
Store Management	Leads to the Store Mngmnt menu, which enables copying of data between internal stores and removable storage. <i>See page 3-248.</i>
Service	Leads to the Service menu, which enables various system functions to be carried out, such as instrument tests, calibration and setting up the instrument according to the user's requirements. <i>See page 3-251.</i>
International	Leads to the International menu, which enables the instrument to be configured for a particular country. <i>See page 3-264.</i>
Applications	Leads to the Applications menu. <i>See page 3-266.</i>

UTILITY

Remote
Control

<u>Remote</u>	<i>See Fig. 3-42.</i> This menu enables the remote control mode to be selected.										
Controlled by RS232	In this mode, the instrument will only expect to receive remote commands over the serial bus.										
Controlled by GPIB	In this mode, the instrument will only expect to receive remote commands over the GPIB.										
No External Controller	In this mode, the instrument will not expect to receive any remote commands.										
Set Up RS232	Leads to the Set Up RS232 menu. Note The number of data bits and stop bits cannot be set from here as they are defaulted when the instrument is being controlled via the RS-232. <i>This will be unselectable unless [Controlled by RS232] is selected.</i>										
GPIB Address	Enables the GPIB address for the 6800A to be set up by entering a number between 0 and 30. <table border="1" data-bbox="418 929 1433 972"> <tr> <td>Rotary Control</td> <td>✕</td> <td>Step Keys</td> <td>✕</td> <td>=Marker</td> <td>✕</td> <td>Numeric Pad</td> <td>√</td> <td>Terminator</td> <td>Any</td> </tr> </table> <i>This will be unselectable unless [Controlled by GPIB] is selected.</i>	Rotary Control	✕	Step Keys	✕	=Marker	✕	Numeric Pad	√	Terminator	Any
Rotary Control	✕	Step Keys	✕	=Marker	✕	Numeric Pad	√	Terminator	Any		
Restore Autotrigger	Returns the instrument to auto-trigger mode if a remote command leaves it in remote trigger mode.										
Return to Utility	Returns to the Utility menu.										

UTILITY

Titles

Titles

See Fig. 3-42. This function allows the user to create the main screen title and also titles for both measurements on Channels 1 and 2.

A form is displayed on the screen showing the screen title, the four measurement titles and whether they are currently on or off. The [\uparrow] and [\downarrow] soft keys are used to move between the titles. The [*On / Off*] soft key is used to turn the currently selected title on or off. The [*Set Title*] soft key is used to change the text of the currently selected title.

On/Off

Toggles the selected title on or off

 \uparrow

Makes the previous title in the form active.

 \downarrow

Makes the next title in the form active.

**Set
Title**

Allows the currently selected title to be set.

**Return to
Utility**

Returns to the Utility menu.

UTILITY

Security

Security

See Fig. 3-42. This menu provides access to the security functions of the instrument.

Secret Freq Display

Used to remove all frequency annotation from the display. The soft key has an on/off toggle action.

Lock Instrument

Used to blank the display and disable the front panel keys and remote control. When this soft key is pressed, a 9 digit security password must be entered and then verified. The instrument remains locked until the security password is entered again, even if the instrument is switched off then on again.

Set Passwords

Leads to the Set Passwords menu, which is used to set the two user-defined passwords. This facility is primary password protected.
See page 3-246.

Return to Utility

Returns to the Utility menu.

UTILITY

Security

Set Passwords

Set Passwords

See Fig. 3-42. A form is displayed on the screen containing the Level 1 and Level 2 user-defined passwords. The soft keys are used to select the password to be changed.

The Set Password function requires entry of the instrument's Primary Password before the user-defined passwords can be changed.

Set Level 1 Password

Enables the Level 1 Password to be set by entering a 4-digit number in the range 1000 to 9999.

Rotary Control	X	Step Keys	X	=Marker	X	Numeric Pad	√	Terminator	Any
----------------	---	-----------	---	---------	---	-------------	---	------------	-----

Set Level 2 Password

Enables the Level 2 Password to be set by entering by entering a 6-digit number in the range 100000 to 999999.

Rotary Control	X	Step Keys	X	=Marker	X	Numeric Pad	√	Terminator	Any
----------------	---	-----------	---	---------	---	-------------	---	------------	-----

Return to Security

Returns to the Security menu.

UTILITY

Set Inc
/ Dec StepsInc/Dec Steps

See Fig. 3-42. This menu enables the user to define the step size that is used when changing numeric parameters with the step keys.

A form is displayed on the screen showing a list of the step sizes and their current value. The [↑] and [↓] soft keys are used to move between the step sizes which can then be changed as follows :

dB

Rotary Control	X	Step Keys	X	=Marker	X	Numeric Pad	√	Terminator	Any
----------------	---	-----------	---	---------	---	-------------	---	------------	-----

Freq (Chan 1), Freq (Chan 2)

Rotary Control	X	Step Keys	X	=Marker	X	Numeric Pad	√	Terminator	10+
----------------	---	-----------	---	---------	---	-------------	---	------------	-----

Watts, Voltage, Units

Rotary Control	X	Step Keys	X	=Marker	X	Numeric Pad	√	Terminator	10-
----------------	---	-----------	---	---------	---	-------------	---	------------	-----

%

Rotary Control	X	Step Keys	X	=Marker	X	Numeric Pad	√	Terminator	Any
----------------	---	-----------	---	---------	---	-------------	---	------------	-----

Distance

Rotary Control	X	Step Keys	X	=Marker	X	Numeric Pad	√	Terminator	10+
----------------	---	-----------	---	---------	---	-------------	---	------------	-----

Time

Rotary Control	X	Step Keys	X	=Marker	X	Numeric Pad	√	Terminator	10-
----------------	---	-----------	---	---------	---	-------------	---	------------	-----



Selects the previous entry in the list of step sizes.

This soft key will be unselectable if the highlight is at the beginning of the list.



Selects the next entry in the list of step sizes.

This soft key will be unselectable if the highlight is at the end of the list.

The function of the next two soft keys depends on which parameter has been selected.

The following additional soft key is present if frequency step is selected**Derive from Span**

This will derive the frequency step from the channel's frequency span.

The following additional soft keys are present if distance step is selected**Metres**

Allows the distance step to be set when the units are metres.

Feet

Allows the distance step to be set when the units are feet.

Return to Utility

Returns to the Utility menu.

UTILITY

Store
Management**Store Mngmnt**

See Fig. 3-42. This menu enables copying of data between internal 6800A stores and removable storage. Stores (but not directories) can also be deleted.

Stores are actually files on removable storage or on the internal flash card, which stores files in a similar way to a hard disk. When one of the soft keys is pressed, a form is displayed listing only files of the specified type; either internal or removable storage stores can be listed.

**Trace
Memory**

Leads to the Manage Stores menu, which allows copying or deleting of Trace Memory stores. *See page 3-249.*

Settings

Leads to the Manage Stores menu, which allows copying or deleting of Instrument Settings stores. *See page 3-249.*

**Print
Options**

Leads to the Manage Stores menu, which allows copying or deleting of Print Options stores. *See page 3-249.*

**Screen
Dumps**

Leads to the Manage Stores menu, which allows copying or deleting of Screen Dump stores. *See page 3-249.*

**Limit
Specs**

Leads to the Manage Stores menu, which allows copying or deleting of Limit Specification stores. *See page 3-249.*

**Power
Cals**

Leads to the Manage Stores menu, which allows copying or deleting of Power Calibration stores. *See page 3-249.*

**Tx Line
Stores**

Leads to the Manage Stores menu, which allows copying or deleting of Transmission Line Database stores. *See page 3-249.*

**Return to
Utility**

Returns to the Utility menu.

UTILITY	Store Management	Trace Memory
UTILITY	Store Management	Settings
UTILITY	Store Management	Print Options
UTILITY	Store Management	Screen Dumps
UTILITY	Store Management	Limit Specs
UTILITY	Store Management	Power Cals
UTILITY	Store Management	Tx Line Stores

Manage Stores

See Fig. 3-42. This menu is used to copy data between internal 6800A stores and removable storage. Stores (but not directories) can also be deleted.

A form is displayed listing stores of the relevant type, i.e. according to the soft key pressed in the previous menu. If the removable storage is not selected, i.e. the indicator on the [USB Memory] soft key is not lit, the list will show internal 6800A stores.

If the [USB Memory] soft key is pressed so that the indicator is lit, stores on the removable storage will be listed. Directories on the removable storage are indicated by enclosing their names in square brackets. A directory is entered by highlighting it using the [↑] and [↓] soft keys then pressing the [Change Directory] soft key. The first soft key in this menu is labelled [Delete] when a store is highlighted and [Change Directory] when a directory is highlighted. To go back to the previous level highlight [..] and press [Change Directory]. Selecting [.] re-displays the list to reflect any changes that have been made. The [Select USB Memory Path] soft key is used to specify the destination directory when copying to removable storage; only directories are listed,

A store is deleted by highlighting it using the [↑] and [↓] soft keys and pressing [Delete].

To copy a store, it is selected as described above; if the store is on removable storage the destination will be internal store and vice versa. Pressing the [Copy] soft key performs the copy operation.

Delete or Change Directory	Deletes the highlighted store.
	Lists the stores in the highlighted directory.

- ↑ Selects the previous entry in the store/directory list.
This soft key will be unselectable if the highlight is at the beginning of the list.
- ↓ Selects the next entry in the store/directory list.
This soft key will be unselectable if the highlight is at the end of the list.

Copy	Copies the selected store to the specified destination.
USB Memory	<p>When selected, the list of memory stores shown will be those found in the current directory on the removable storage currently inserted in the USB port. As well as the list of memory stores any directories found in the current directory will also be shown. The [ENTER / =MKR] key is used to change directory.</p> <p>Note Access to the removable storage is global to the instrument and the state is preserved across visits to all menus that can access the USB ports.</p>
Select USB Memory Path	<p>When this soft key is pressed, only directories on the removable storage are listed. A sub-menu is displayed containing [\uparrow], [\downarrow] and [<i>Change Directory</i>] soft keys; these are used to set the destination path when copying to removable storage.</p> <p><i>This soft key is only selectable when USB Memory (above) is not selected.</i></p>
Spreadsheet Format	<p>When selected, the list of stores shown will be those that contain trace measurements that are in the spreadsheet (CSV) format.</p> <p><i>This soft key is only selectable when the store type is Trace Memory.</i></p>
Return to Store Mngmnt	Returns to the Store Mngmnt menu.

UTILITY

Service

<u>Service</u>	<i>See Fig. 3-44. This menu provides various service functions.</i>
Set-up	Leads to the Set-up menu, which provides several instrument setup functions. <i>See page 3-252.</i>
Status	Leads to the Status menu, which allows the user to examine the power on test results and the build state of the instrument. <i>See page 3-255.</i>
Instrument Calibrations	Leads to the Instrument Cals menu, which provides calibration facilities for the instrument. <i>See page 3-256.</i>
Tests	Leads to the Tests menu, which enables display and keyboard tests to be performed. <i>See page 3-262.</i>
Upgrade Instrument	Used to install upgraded software for the instrument, supplied on removable storage. When this soft key is pressed, the user is prompted to insert each device in turn and press <i>[Continue]</i> when ready. The instrument must be turned off then on again to complete the installation. This facility is Primary Password protected.
Diagnostics	Leads to the Diagnostics menu, which provides some basic diagnostic tools. <i>See page 3-263.</i>
Return to Utility	Returns to the Utility menu.

UTILITY

Service

Set-up

Set-up

See Fig. 3-45. This menu provides facilities for setting up the display and setting the instrument's real-time clock,.

Display

Leads to the Display menu, which enables the display brightness to be set, and also provides a screen blanking facility.
See page 3-253.

**Set Date
& Time**

Leads to the Date & Time menu, which is used for setting the instrument's real time clock.
See page 3-254.

**Reset Op
Hours Clock**

This is used to reset the instrument operating hours count to zero. Primary Password protected.

**Set Serial
Number**

This is used to set the instrument's serial number. Primary Password protected.

**Set 6800
Options**

Allows the instrument's hardware options to be specified. Primary Password protected.

**Return to
Service**

Returns to the Service menu.

UTILITY

Service

Set-up

Display

<u>Display</u>	<i>See Fig. 3-45.</i> This menu provides facilities for setting up aspects of the instrument's LCD display.
Maximum Brightness	Sets the LCD backlight to maximum brightness.
High Brightness	Sets the LCD backlight to high brightness.
Low Brightness	Sets the LCD backlight to low brightness.
Minimum Brightness	Sets the LCD backlight to minimum brightness.
Colour Palettes	Leads to the Colour Palette menu that enables a new set of colours to be selected. <i>See page 3-253.</i>
Return to Set-up	Returns to the Utility menu.

UTILITY

Service

Set-up

Display

Colour Palettes

<u>Colour Palettes</u>	<i>See Fig. 3-45.</i> This menu allows the colour scheme used by the display to be selected..
Colour	Selects the colour display.
White on Black	Selects the white on black display.
Black on White	Selects the black on white display.
Green on Black	Selects the green on black display.
Monochrome	Selects the greyscale display.
Return to Display	Returns to the Display menu.

UTILITY

Service

Set-up

Set Date
& Time**Date & Time**

See Fig. 3-45. This function is used to set the instrument's real-time clock and calendar.

A form is displayed on the screen showing the current time and date, together with soft keys for parameter selection. The instrument's date and time are not changed until the [Store Date & Time] soft key is pressed.

**Enter
Time**

Allows a new time to be entered. The hour field will be selected initially. The pressing of a terminator key will move the selection to the next time field.

Rotary Control	✕	Step Keys	✕	=Marker	✕	Numeric Pad	√	Terminator	Any
----------------	---	-----------	---	---------	---	-------------	---	------------	------------

**Enter
Date**

Allows a new date to be entered. The day (or month, depending upon the country selection) field will be selected initially. The pressing of a terminator key will move the selection to the next date field.

Rotary Control	✕	Step Keys	✕	=Marker	✕	Numeric Pad	√	Terminator	Any
----------------	---	-----------	---	---------	---	-------------	---	------------	------------

**Store Date
& Time**

Causes the entered date and time to be checked. If the checks fail a message will be displayed and the error must be corrected before the new date and time will be accepted. If the checks pass then the instrument's real-time clock and calendar will be updated with the entered values.

**Return to
Set-up**

Returns to the Set-up menu. If the currently entered date and time have not been stored then the instrument will display a prompt asking if they are to be saved..

UTILITY

Service

Status

Status

See Fig. 3-44. This menu allows the user to examine the power on test results and the build state of the instrument and its boards.

Display Test Results

Displays the results of the tests that the instrument performs when it is switched on. The 6800A maintains records in non-volatile memory of the time and date of the most recent failure for each test.

Erase Test Results

Clears the power on test results, i.e. sets all the tests to 'pass'. This function is confirmation protected.

Display Build State

Displays the build state of the instrument, including the total number of hours that the instrument has been operating, and the time and data of the most recent frequency standard cal and power reference cal. A *[Print]* soft key is displayed which enables a hard copy printout to be obtained.

The instrument's build state can also be printed out by pressing the [PRINT] key on power up.

Display Patent Information

Lists any patents relating to the 6800A series of instruments.

Get ID ROM Details

Displays build state information for each printed circuit board within the instrument, which is held in ROM.

Return to Service

Returns to the Service menu.

UTILITY

Service

Instrument
Calibrations

Instrument Cals See Fig. 3-46. This menu provides facilities for self calibration of the instrument.

The calibration process is controlled automatically by the 6800A. For operations taking more than a few seconds to complete, a percentage complete indicator will be displayed after the function has been initiated.

When operating the unit at the extremes of its rated temperature range, particularly below -10°C , it may be necessary to perform a User Frequency Cal of either the RF Source or the Spectrum Analyzer or both. This occurs because the lock range of the synthesizers is much less than the total tuning range, and stored pre-steer correction voltages are derived by the calibration routine to achieve lock. The prompt for performing the user cals is indicated by the flashing 'Unloc' indicator at the top of screen.

Before initiating the calibration routine it is useful to determine first which part of the unit is generating the 'Unloc' indication. This is achieved with the following key presses:

[UTILITY] [Service] [Diagnostics] ['Unloc' Diagnostics]

The flashing 'Unloc' will be replaced by six dashes (-----) while there is no 'Unloc' indication and one or more of the dashes will be replaced by an upper case letter in the range A to F in place of the 'Unloc'.

The letters A, B or C indicate the 'Unloc' is in the RF Source; the letters D or E indicate the 'Unloc' is in the Spectrum Analyzer. The letter F is common to both parts as it refers to the 10MHz frequency standard module.

The User Cal is performed in each case by selecting the appropriate menu and initiating the user cal by pressing the [Perform Frequency Cal] softkey. No additional connection or disconnection of front panel cables is required to do this as it is performed automatically by the unit software.

RF Source Calibrations	Leads to the RF Source Cals menu. See page 3-257.
Spec Ana Cals	Leads to the Spec Ana Cals menu. See page 3-261.
Return to Service	Returns to the Service menu.

UTILITY

Service

Instrument
CalibrationsRF Source
Calibrations**RF Source Cals**

See Fig. 3-46. This menu provides facilities for calibrating the instrument's source and internal frequency standard.

**Frequency
Standard Cal**

Used to calibrate the instrument's internal frequency standard against an external standard. The user is prompted to connect the external standard to the **FREQ STANDARD INPUT/OUTPUT** connector on the rear panel and press [*Continue*] when ready. Pressing [*Abort*] terminates the calibration process.

This facility is User Level 2 Password protected.

**Perform
Frequency Cal**

Calibrates the oscillators of the instrument's source.

**Broadband
Power Cal**

Used to carry out a power calibration of the instrument's source over its full frequency range. This facility is User Level 1 Password protected.

Leads to the Bband Power Cal menu.

See page 3-258.

**Narrowband
Power Cal**

Used to carry out a power calibration of the instrument's source over a limited frequency range. This facility is User Level 1 Password protected.

Leads to the Nband Power Cal menu.

See page 3-259.

**Power Cal
Functions**

Leads to the Power Cal Funcs menu.

See page 3-260.

**Perform
FM Cal**

Used to calibrate the frequency modulation circuits of the instrument's source.

**Return to
Instrument Cals**

Returns to the Instrument Cals menu.

UTILITY

Service

Instrument
CalibrationsRF Source
CalibrationsBroadband
Power Cal

Bband Power Cal See Fig. 3-46. This menu is used to perform a broadband power calibration of the instrument's source, i.e. over its full frequency range.

The user is prompted to connect a detector (6230A/L series) to INPUT A and to the SIGNAL SOURCE OUTPUT connector and press [Continue] when ready. The [Select Power Cal Store] soft key is used to save the calibration data to a specified store.

Note Instead of calibrating at the SIGNAL SOURCE OUTPUT connector, calibration may be carried out at the output of any cables, adapters, etc. that are connected to the signal source output.

Continue Initiates the broadband power calibration

Pulse Mod Cal This soft key appears only when Option 25 is fitted. Carry out the standard broadband calibration as indicated above, then press this key. Carry out a repeat broadband calibration that now takes into account the different signal routing for pulse modulated signals.

Select Power Cal Store Leads to the Select Store menu.
See page 3-258

Abort Terminates the calibration process.

UTILITY

Service

Instrument
CalibrationsRF Source
CalibrationsBroadband
Power CalSelect Power
Cal Store

Select Store See Fig. 3-46. This menu is used to select a store in which to save calibration data.

A form is displayed listing the identities of the available calibration stores (either broadband or narrowband). To save the data to a specific calibration store, the name is selected from the list. Alternatively, a new calibration store can be created by entering a new name in the appropriate entry field.

Select Saves the power calibration data to the selected store.

↑ Selects the previous entry in the list of calibration stores. The list automatically scrolls, if necessary, when the highlight reaches the top of the list.

This soft key will be unselectable if the highlight is at the beginning of the list.

↓ Selects the next entry in the list of calibration stores. The list automatically scrolls, if necessary, when the highlight reaches the bottom of the list.

This soft key will be unselectable if the highlight is at the end of the list

New Store Name Enables a new calibration store name to be entered.

Return to Calibration Returns to the previous menu.

UTILITY

Service

Instrument
CalibrationsRF Source
CalibrationsNarrowband
Power Cal

Nband Power Cal See Fig. 3-46. This menu is used to perform a narrowband power calibration of the instrument's source, i.e. over a user-defined frequency range.

The narrowband calibration facility enables a power calibration to be performed over a limited frequency range. This makes it possible to calibrate the instrument at the output of frequency selective devices such as filters and amplifiers.

A window is displayed showing the frequency range the calibration will cover (initially the entire range of the source). The frequency range is specified using the *[Set Start Frequency]* and *[Set Stop Frequency]* soft keys. The user is prompted to connect a detector (6230A/L series) to INPUT A and to the SIGNAL SOURCE OUTPUT connector and press *[Continue]* when ready. The *[Select Power Cal Store]* soft key is used to save the calibration data to a specified store.

Note Instead of calibrating at the SIGNAL SOURCE OUTPUT connector, calibration may be carried out at the output of any cables, adapters, etc. that are connected to the signal source output.

Continue	Initiates the narrowband power calibration.
Pulse Mod Cal	This soft key appears only when Option 25 is fitted. Carry out the standard narrowband calibration as indicated above, then press this key. Carry out a repeat narrowband calibration that now takes into account the different signal routing for pulse modulated signals.
Set Start Frequency	Sets the lower limit of the calibration frequency range.
Set Stop Frequency	Sets the upper limit of the calibration frequency range.
Select Power Cal Store	Leads to the Select Store menu. <i>See page 3-258</i>
Abort	Terminates the calibration process.

UTILITY

Service

Instrument
CalibrationsRF Source
CalibrationsPower Cal
Functions

Power Cal Funcs See Fig. 3-46. This menu provides additional power calibration functions.

**Transfer to
Primary Cal**

Transfers a user power calibration into the primary calibration store (contains the factory generated power calibration data). A sub-menu is displayed which allows selection of the user power calibration store to be transferred. This is similar to the Select Store menu (page 3-258) except that there is no *[New Store Name]* soft key. This function is Primary Password protected.

**Select User
Power Cal**

Used to select which user power calibration is to be used in the instrument. A sub-menu is displayed which allows selection of the user power calibration store. This is similar to the Select Store menu (page 3-258) except that there is no *[New Store Name]* soft key.

**Select Primary
Power Cal**

Selects the primary calibration. Power calibration data stored in the primary cal store will be used in the instrument for non-pulse mode operation.

**Transfer to
Pulse Mod Cal**

Transfers a user power calibration into the pulse modulation calibration store (contains the factory-generated power calibration data). A sub-menu is displayed which allows selection of the user power calibration store to be transferred. This is similar to the Select Store menu (page 3-258) except that there is no *[New Store Name]* soft key. This function is Primary Password protected.

**Select User
Pulse Mod Cal**

Used to select which user power calibration is to be used in the instrument. A sub-menu is displayed which allows selection of the user pulse modulation calibration store. This is similar to the Select Store menu (page 3-258) except that there is no *[New Store Name]* soft key.

**Select Primary
Pulse Mod Cal**

Selects the primary pulse modulation calibration. Power calibration data stored in the primary pulse mod cal store will be used in the instrument for pulse mode operation.

**Return to
RF Src Cals**

Returns to the RF Source Cals menu.

UTILITY

Service

Instrument
CalibrationsSpec Ana
Calibrations**Spec Ana Cals**

See Fig. 3-46. This menu provides facilities for calibrating the spectrum analyzer section of 6840A series instruments.

These functions are User Level 2 Password protected.

**LO Frequency
Cal**

Acquires core synthesiser loop gain data, YIG linearity data and FM sensitivity data.

**RBW Filter
Cal**

Calibrates the resolution bandwidth filters so that they give the correct bandwidths when they are selected from the front panel. The insertion loss associated with each bandwidth setting is recorded so that an appropriate offset can be applied to the measurement. The user is prompted to connect the SIGNAL SOURCE OUTPUT and SPECTRUM ANALYZER connectors and to press [*Continue*] when ready. It is assumed that the source has previously been calibrated.

**YIG Filter
Cal**

Calibrates the drive signal for the YIG pre-selector filter to ensure that at each measurement frequency the filter's passband is centred on the input signal. The user is prompted to connect the SIGNAL SOURCE OUTPUT and SPECTRUM ANALYZER connectors and to press [*Continue*] when ready.

**Amplitude
Cal**

Removes the frequency response errors due to all the spectrum analyzer front end components. The user is prompted to connect the SIGNAL SOURCE OUTPUT and SPECTRUM ANALYZER connectors and to press [*Continue*] when ready.

**Log Amp
Lin Cal**

Acquires calibration data to allow the log amplifier / detector measurements to be corrected over the range -40 dBm to 0 dBm.

Full details are not yet available.

**Return to
Instrument Cals**

Returns to the Instrument Cals menu.

UTILITY

Service

Tests

Tests

See Fig. 3-44. This menu enables the operator to verify that the display and keyboard are functioning correctly.

**Test
Keyboard**

Allows each key on the front panel to be tested individually, and allows the rotary control to be tested for clockwise and anti-clockwise rotation.

A form is displayed on the screen containing a representation of the front panel key layout. For each keypress or rotary control movement detected, the corresponding symbol on the front panel representation will be highlighted, and remains highlighted for the duration of the test. The [Exit] soft key terminates the test.

**Test
Display**

Leads to the Test Display menu.
See page 3-262.

**Return to
Service**

Returns to the Service menu.

UTILITY

Service

Tests

Test
Display**Test Display**

See Fig. 3-44. This menu enables the operator to verify that all the display pixels are functioning correctly.

Pixel Off

Causes all the pixels on the display to be turned off. The test is used to indicate 'stuck on' pixels on the LCD.

Pixel On

Causes all the pixels on the display to be turned on at maximum brightness. The test is used to indicate 'stuck off' pixels on the LCD.

**Remove
menu**

Removes the menu from the instrument display so that the test pattern covers the whole of the LCD. Pressing any key will restore the menu.

Exit

Returns to the Tests menu.

UTILITY

Service

Diagnostics

Diagnostics

See Fig. 3-44. This menu provides facilities for checking the contents of registers, and which part of the instrument is generating an 'Unloc' display.

Peek & Poke

Leads to the Peek & Poke menu, which is intended for use by service technicians only. This function is Primary Password protected.
See page 3-253.

'Unloc' diagnostics Leads to diagnostics that determine which part of the unit is generating the 'Unloc' indication, as described on page 3-256.

Return to Service

Returns to the Service menu.

UTILITY

International

International

See Fig. 3-43. This function enables the following country specific instrument settings to be set :

Language - text is displayed in the selected foreign language, and supports the special character requirements of French, German and Spanish.

Keyboard layout - If an external keyboard is used, the layout can be specified according to the country.

Date format - Different date formats can be specified (e.g. 03/12/1997, 03.12.1997).

Time Format - Different time formats can be specified (e.g. 17:35:20, 5:35:20p).

Decimal point - The decimal point can be either a full stop or a comma (if a comma is selected the spreadsheet field separator will be automatically set to semicolon to avoid ambiguity).

Spreadsheet separator - When creating files in Spreadsheet (CSV) format, either a comma or semicolon can be used as a field separator.

Although it is possible to change the international settings independently, as above, default combinations can be set by setting the **Country** parameter to the required country, as shown below:

	UK	France	Germany	Spain	USA
Language	English	French	German	Spanish	English (US)
Keyboard	British	French	German	Spanish	US
Date & Time format	03/12/1998 17:35:20	03.12.1998 17:35:20	03.12.1998 17:35:20	03/12/1998 17:35:20	03/12/1998 5:35:20p
Spreadsheet	a, b, c,	a; b; c;	a; b; c;	a; b; c;	a, b, c,
Decimal Point	1.5	1,5	1,5	1,5	1.5

A form is displayed on the screen showing the current settings. The [\uparrow] and [\downarrow] soft keys are used to move between the parameters. A list of the available values for the highlighted parameter appears below the parameters section of the form. The [*Change*] soft key is used to move the highlight into the selection list so that a new value for the parameter can be selected, by pressing [*Select*]. The [*Go to Param Selection*] soft key moves the highlight back into the parameters section..

The functions of the soft keys depend on whether or not a parameter has been selected.

No parameter selected

Change Moves the selection highlight into the parameter values list.

\uparrow Selects the previous parameter.

\downarrow Selects the next parameter.

Install New Locale Leads to the New Locale menu, which enables new country setting to be installed from removable storage.
See page 3-265

Parameter selected

Select Sets the parameter to the currently selected value in the list.

↑ Selects the previous entry in the list of values. The list automatically scrolls, if necessary, when the highlight reaches the top of the list.

This soft key will be unselectable if the highlight is at the beginning of the list

↓ Selects the next entry in the list of values. The list automatically scrolls, if necessary, when the highlight reaches the bottom of the list.

This soft key will be unselectable if the highlight is at the end of the list

Go to Param Selection Causes the selection highlight to move to the parameters section of the form

Return to Utility Returns to the Utility menu.

UTILITY

International

Install New Locale

New Locale *See Fig. 3-43.* This menu is used to install a new set of country settings from removable storage.

A form is displayed that shows the list of country settings that are on the removable storage device.

Add Copies the currently highlighted country setting to the instrument.

↑ Selects the previous entry in the list of country settings. The list automatically scrolls, if necessary, when the highlight reaches the top of the list.

This soft key will be unselectable if the highlight is at the beginning of the list.

↓ Selects the next entry in the list of country settings. The list automatically scrolls, if necessary, when the highlight reaches the bottom of the list.

This soft key will be unselectable if the highlight is at the end of the list.

Return to International Returns to the International menu.

UTILITY

Applications

Applications

See Fig. 3-43. This menu is used to install or remove, and control the automatic execution of, application programs.

Applications provide step-by-step guidance to the operator for a particular type of measurement, via prompts and diagrams. It is not necessary for the user to be familiar with the theory of the measurement, nor with the instrument's operation and menu structure.

Once installed, the application is run using the [RUN APPS] key.

**Install
Application**

Leads to the Install App menu, which enables application programs to be installed from removable storage.

See page 3-267.

**Remove
Application**

Leads to the Remove App menu, which enables installed application programs to be removed from the instrument's non-volatile memory.

See page 3-267.

Auto Run

Toggles the auto run feature on and off. When the instrument powers up, and auto run was previously enabled, the application that has been designated as auto run will be automatically executed.

**Mark as
Auto Run**

Leads to the Auto Run menu, which enables an installed application program to be designated as auto run.

See page 3-268.

**Return to
Utility**

Returns to the Utility menu.

UTILITY

Applications

Install
Application**Install App**

See Fig. 3-43. This menu is used to install applications into the instrument from removable storage.

A form is presented with a list of all the available applications on the removable storage.

Install

Installs the currently selected application.



Selects the previous entry in the list of applications. The list automatically scrolls, if necessary, when the highlight reaches the top of the list.

This soft key will be unselectable if the highlight is at the beginning of the list.



Selects the next entry in the list of applications. The list automatically scrolls, if necessary, when the highlight reaches the bottom of the list.

This soft key will be unselectable if the highlight is at the end of the list.

**Return to
Applications**

Returns to the Applications menu.

UTILITY

Applications

Remove
Application**Remove App**

See Fig. 3-43. This menu is used to remove applications from the instrument's non-volatile memory.

A form is presented with a list of all the currently installed applications.

Remove

Removes the currently selected application.

Note This will be confirmation protected.



Selects the previous entry in the list of applications. The list automatically scrolls, if necessary, when the highlight reaches the top of the list.

This soft key will be unselectable if the highlight is at the beginning of the list.



Selects the next entry in the list of applications. The list automatically scrolls, if necessary, when the highlight reaches the bottom of the list.

This soft key will be unselectable if the highlight is at the end of the list.

**Return to
Applications**

Returns to the Applications menu.

UTILITY

Applications

Mark as
Auto Run**Auto Run**

See Fig. 3-43. This menu is used to designate an application as being the one that is automatically executed upon power up.

A form is presented with a list of all the currently installed applications.

Select

Designates the currently selected application as the one to be executed on power up.



Selects the previous entry in the list of applications. The list automatically scrolls, if necessary, when the highlight reaches the top of the list.

This soft key will be unselectable if the highlight is at the beginning of the list.



Selects the next entry in the list of applications. The list automatically scrolls, if necessary, when the highlight reaches the bottom of the list.

This soft key will be unselectable if the highlight is at the end of the list.

**Clear
Auto Run**

Removes the auto run flag from the application that is currently designated.

**Return to
Applications**

Returns to the Applications menu.

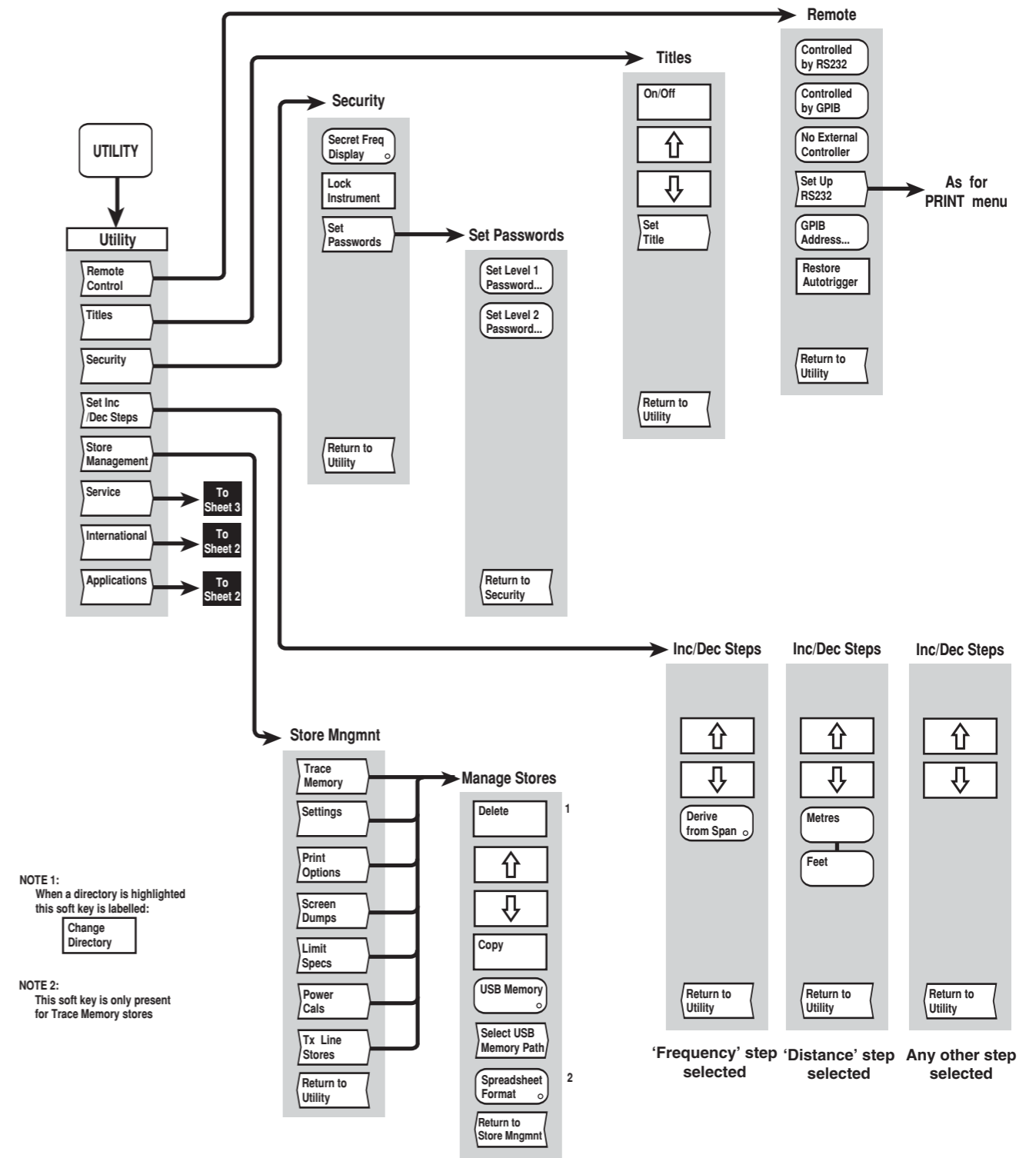
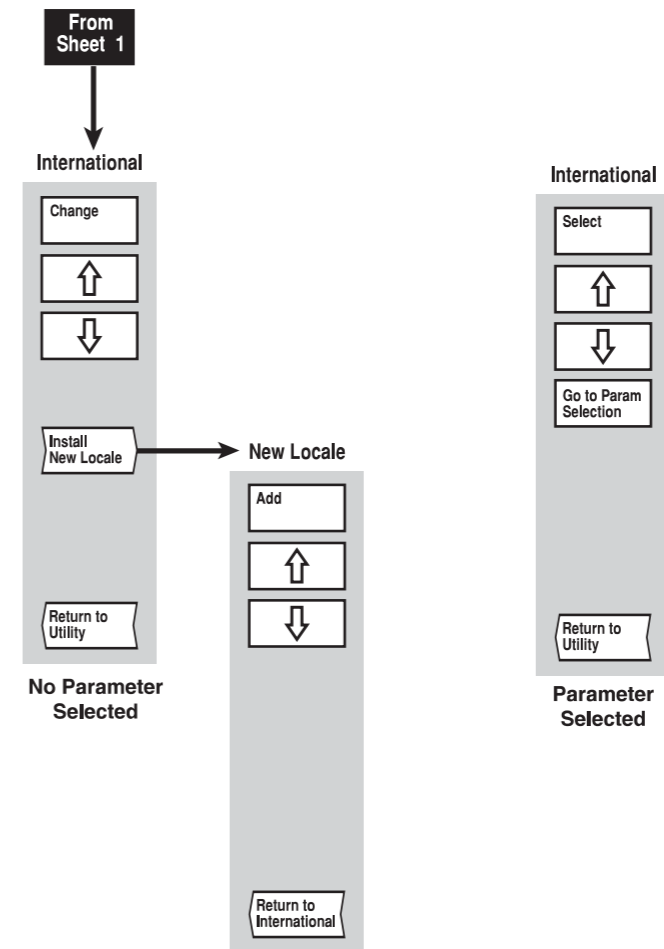
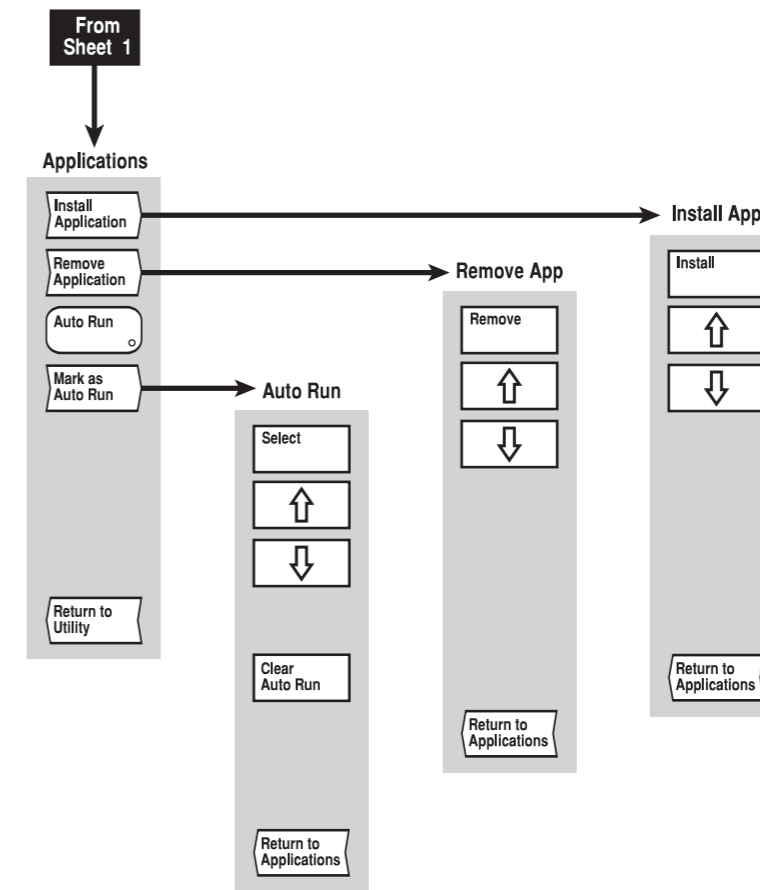

Fig. 3-42 UTILITY menus (sheet 1)

C6259

Fig. 3-42 UTILITY menus (sheet 1)



C3655

Fig. 3-43 UTILITY menus (sheet 2)

Fig. 3-43 UTILITY menus (sheet 2)

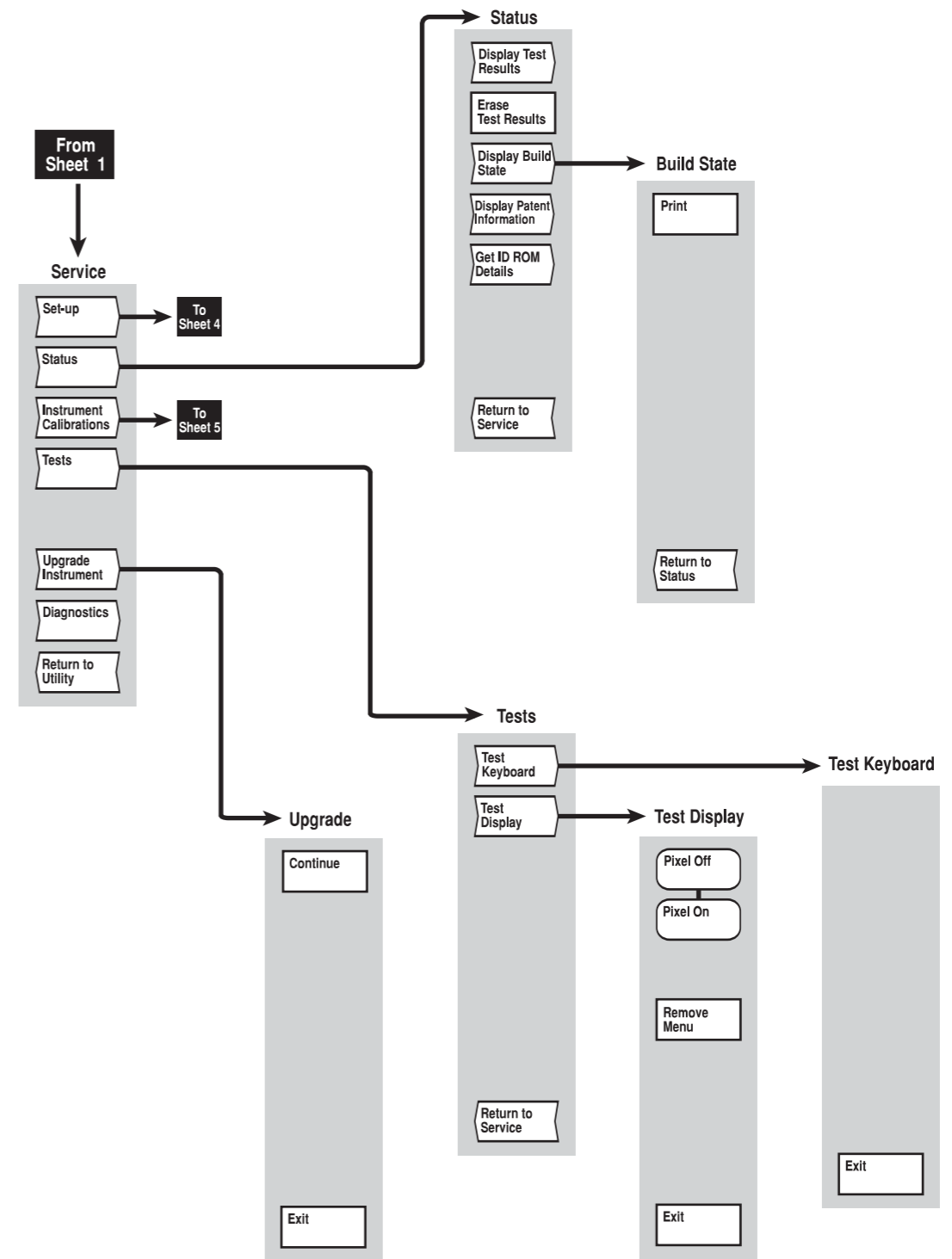

C4959

Fig. 3-44 UTILITY menus (sheet 3)

Fig. 3-44 UTILITY menus (sheet 3)

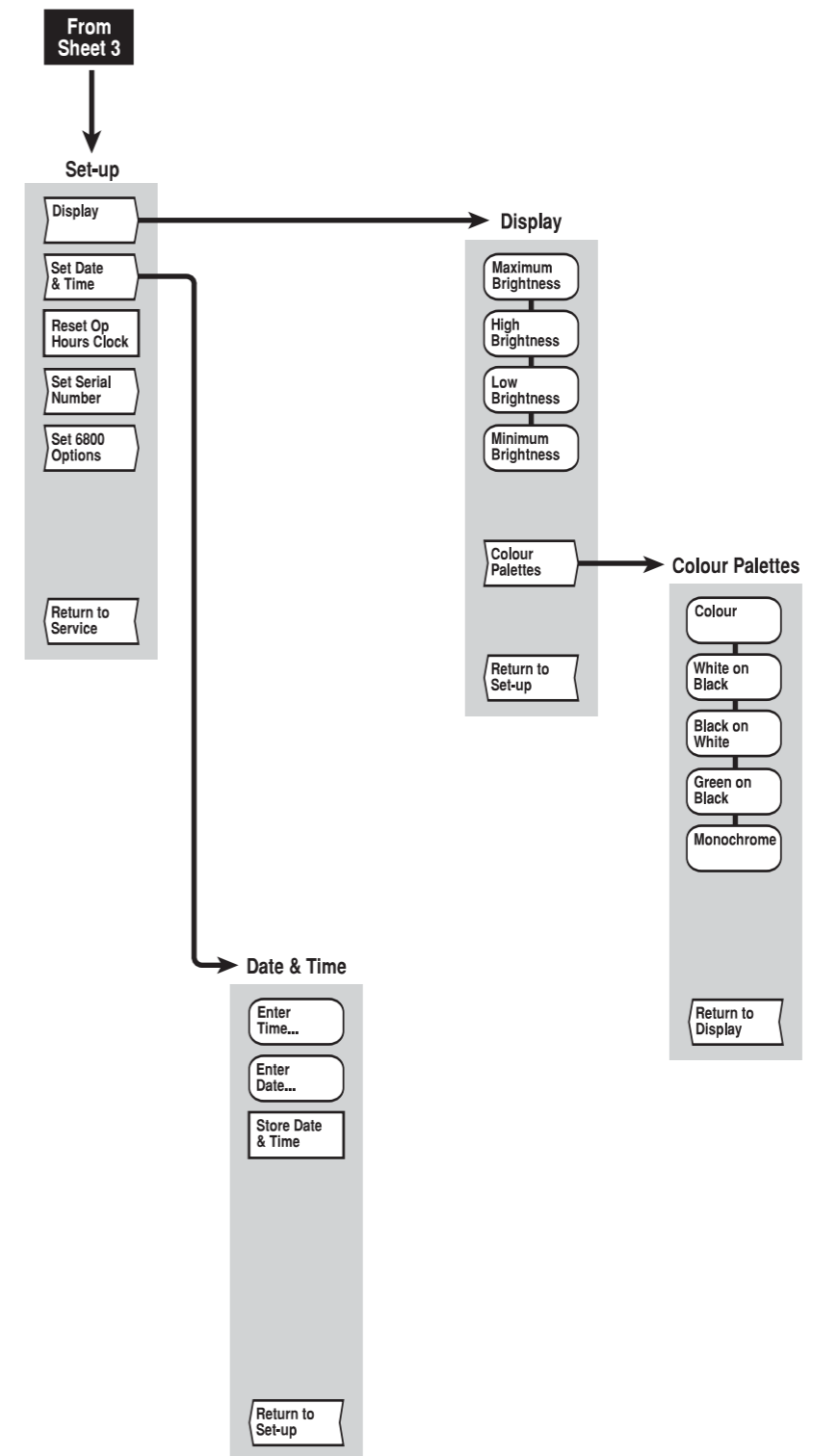

C3657

Fig. 3-45 UTILITY menus (sheet 4)

Fig. 3-45 UTILITY menus (sheet 4)

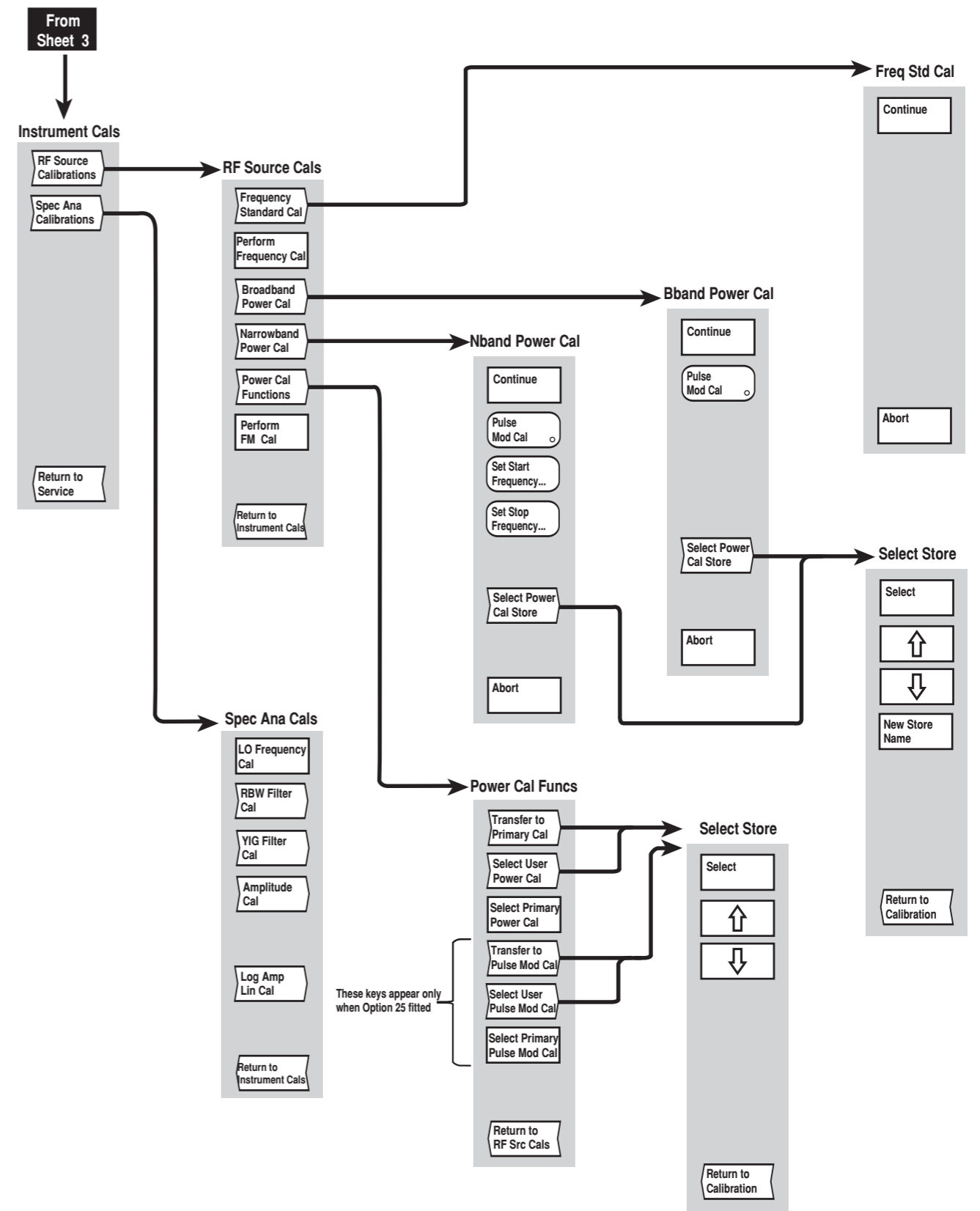

C6230

Fig. 3-46 UTILITY menus (sheet 5)

Fig. 3-46 UTILITY menus (sheet 5)

[LOCAL] key

The [LOCAL] key does not have an associated menu structure. It is used to return the instrument to local (front panel) operation after being put into the remote state by a controller. If the instrument was being triggered by the controller, then a prompt will appear asking whether or not the instrument is to be returned to the autotrigger mode of operation.

This is the only front panel key that is not disabled when the instrument is remotely controlled over the serial bus or GPIB. The exception to this is when local lockout is in effect; this is a remote command that disables the [LOCAL] key making it difficult to interfere with the 6800A while it is under remote control.

[PRESET] key

The [PRESET] key provides a menu which enables the instrument to be set to a known condition.

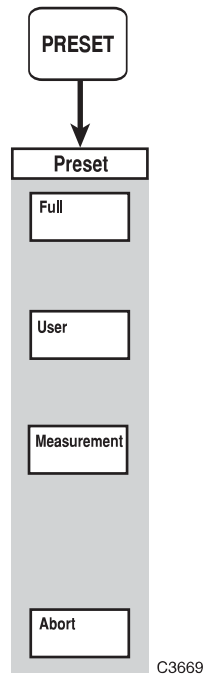

Fig. 3-47 PRESET menu

PRESET**Preset**

This menu is used to set the instrument into a known state.

If an application will be automatically run after the preset operation then a message will be displayed giving the application's name.

Full

Returns the instrument to its default set-up conditions, as detailed in Appendix A.

User

Sets the instrument to the conditions defined by the contents of the user default settings store (see Save/Recall menu, [*Save Settings as User Default*] soft key).

This soft key will be unselectable if the preset setting stores does not contain valid data.

Measurement

Sets default measurement settings on the current channel (both channels if channel coupling is on and both are the same type), without affecting the number of channels and measurements displayed and their types.

Abort

Aborts the preset operation.

[SOURCE ON/OFF] key

The [SOURCE ON/OFF] key does not have an associated menu structure. It is used to toggle the instrument's RF output on and off.

Chapter 4

BRIEF TECHNICAL DESCRIPTION

Contents

Introduction	4-1
System Control Board, A1/1	4-1
Frequency Standard Board, A2	4-2
Synthesized source	4-2
Core Synthesizer Board, AS1	4-3
Frequency Band Selection & Control Board, AS2	4-3
Signal Conditioning Board, AS3	4-3
Microwave source block	4-3
Data Acquisition Board, AD1	4-4
Internal Modulation Board, AG1F	4-4
Pulse Modulator and Microwave Switch, AS6	4-4
Spectrum analyzer	4-4
Input Distribution Block	4-4
1st LO Block and SA Synthesiser Board, AR4	4-5
Harmonic mixer	4-5
Sweep Control Board, AR3	4-5
Spectrum Analyzer Interface Board, AR11	4-5
Down-Converter Block	4-5
1st IF System, AR1	4-6
2nd IF System, AR2	4-6
Power supply	4-6

List of figures

Fig. 4-1 System block diagram (sheet 1)	4-7
Fig. 4-2 System block diagram (sheet 2)	4-9

Introduction

The description which follows is intended as an overview of the 6800A series hardware, and relates to the functional blocks of the instrument as shown in Figs. 4-1 and 4-2, which are simplified block schematic diagrams of the instrument. Fig. 4-2 and the related spectrum analyzer description apply only to the 6840A versions. A more detailed description is given in Chapter 1 of the Maintenance Manual.

System Control Board, A1/1

All the main control, processing and interface functions of the 6800A are carried out by the System Control board A1/1. This assembly consists of a main carrier board that supports two ETX-format computer modules. One of the ETX modules runs the Phar-Lap operating system and associated software to control the 6800A hardware. The second ETX module (known as the I/O processor) performs I/O interfacing functions (graphics and USB) running under the Linux operating system. The two ETX modules communicate with each other via a bi-directional FIFO link. The following are examples of the type of ETX module that may be used:

Phar-Lap processor

Intel® Celeron® M CPU 600 MHz, 512 MB RAM, providing the following features:

- 16-bit I/O
- 16-bit DMA
- 2 x IDE interfaces
- parallel port
- 2 x serial ports
- Interface to external PS/2 keyboard

I/O processor

AMD® LX800 CPU 500 MHz, 512 MB DRAM providing the following features:

- 2 x USB
- 2 x IDE
- 18-bit parallel LCD interface
- VGA interface

The software for both processors resides on a Compact Flash (CF) memory card (one per processor). The CF card on the Phar-Lap side is also used to store factory pre-set data and user data.

Additionally, the A1/1 board provides the following features:

- GPIB interface
- Non-volatile RAM (NOVRAM)
- Interface to front panel keyboard
- Trigger and lock interface to replace the AT1 option board

The A1/1 board plugs into a dedicated slot in the system motherboard. All interfaces to the system (with the exception of USB and trigger/lock connections) are made via the system motherboard. Two motherboard connectors are provided: the ISA bus connector is a 96-way DIN41612, the remainder of the motherboard connections are made via a 192-way (4 x 48 row) 2 mm metric connector.

Frequency Standard Board, A2

For many of its functions the 6800A requires a 10 MHz reference frequency; this is derived from a 100 MHz VCXO. When the instrument is set to internal standard, the VCXO is locked to a 10 MHz oven-controlled crystal oscillator (OCXO) using a phase-locked loop (PLL). The OCXO is tuned by the output of a DAC which receives data from the ISA bus. A 10 MHz output is provided on the rear panel. Alternatively, the VCXO can be locked to a 1 or 10 MHz external standard (via the same rear panel connector).

Synthesized source

The 6800A signal source comprises:

Core Synthesizer Board, AS1, which utilises a fractional-N synthesizer to generate signals over the range 1.5–3 GHz.

Frequency Band Selection & Control Board, AS2, which takes the AS1 output and produces output signals from 1 MHz to 1.5 GHz. It also contains the levelling control for RF and microwave signals.

Signal Conditioning Board, AS3, which provides amplification, level control and filtering of the signals generated by boards AS1 and AS2.

Core Synthesizer Board, AS1

A programmable divider (using the IFR patented fractional-N architecture) generates signals in the range 1.5 - 3 GHz by phase-locking an oscillator to the 10 MHz reference signal output by the Frequency Standard Board, A2. To avoid the need for an oscillator that operates up to 3 GHz, a 500 - 667 MHz VCO is used and low-order harmonics are generated. The VCO output is fed to a harmonic generator to produce the 3rd, 4th and 5th harmonics; one of these is selected by a voltage-tuned filter to yield a signal in the range 1.5 - 3 GHz.

The frequency of the VCO is set to the required value by setting the correct division ratio and pre-steering the VCO; this is controlled by software via the digital interface

Frequency Band Selection & Control Board, AS2

In addition to generating signals from 1 MHz to 3 GHz, the AS2 board also acts as the master controller for the source, communicating with the System Control Board via the ISA bus.

The 1.5 - 3 GHz output from AS1 is divided by 2 and 4 to produce signals in the range 750 - 1500 MHz and 375 - 750 MHz respectively. A mixer is used to generate signals from 1 to 375 MHz; with a local oscillator of 1.5 GHz the corresponding mixer input frequency range is 1501 - 1875 MHz. The local oscillator is a 1.5 GHz VCO phase-locked to the 10 MHz reference frequency. PIN diode switches are used to select either the 1.5 - 3 GHz through path, one of the divider outputs, or the mixer output, which is fed to the AS3 board.

The levelling control circuit comprises the control circuitry for maintaining constant power levels at the outputs of AS3 and the microwave block. The output power levels are monitored by diode detectors, and the control loops provide drive signals for the corresponding PIN diode modulators. The levelling control circuit can also be used with an external detector or power meter, connected to the rear panel EXT LEVEL INPUT connector.

Signal Conditioning Board, AS3

The function of the AS3 board is to amplify the synthesized signal from AS2, and to reduce the harmonics present in the output signal (both the input signal and the power amplifier contribute towards the harmonic content). The board also provides a means for levelling the output power.

The 1 MHz - 3 GHz output from AS2 is fed to a PIN diode modulator used as a variable attenuator. This forms part of the levelling system, the control circuitry residing on AS2. The signal is then passed to a power amplifier which provides a nominal 27 dB of gain. This increases the AS2 output power and compensates for loss in the other signal conditioning circuits, to provide an output power > +10 dBm at the front panel over the entire frequency range.

The filter stage comprises 11 half-octave filter sections, which are switched in as appropriate to cover different bands.

A resistive pick-off provides a sample of the output signal to the diode detector, which gives a DC output voltage that is proportional to the power level. This is fed to the control circuit on AS2 which provides levelling control for signals below 3 GHz.

Microwave source block

The microwave source block provides the source frequencies covering the range 3 - 24 GHz, except for the lower frequency variants 6821 and 6841. The frequencies are generated by a bank of up to 5 microwave VCOs (depending on the frequency range of the variant). Each VCO is followed by a low-pass filter to reduce harmonics. An SP6T PIN diode switch selects either one of the VCO outputs or the 1 MHz - 3 GHz output from AS3.

A sample of the selected signal is passed to a phase-locked loop for phase-locking signals above 3 GHz to the 600 - 800 MHz local oscillator output from AS2.

The SP6T switch output is followed by a broadband PIN diode modulator which, together with a broadband directional coupler and control circuitry on AS2, form the levelling circuit for frequencies above 3 GHz. The levelling system is used to achieve constant power and good source match. The modulator is used to adjust the source output power level. If fitted, the optional step attenuator is fitted between the microwave block and the RF output connector.

Data Acquisition Board, AD1

The data acquisition system consists of three amplifier chains for detector inputs A, B and C. Each chain has two switched-gain stages, providing a total of 6 gain settings. A calibration DAC allows automatic calibration of each gain combination on each of the three amplifier chains. A further DAC is used for zeroing of the first amplifier stage. The output of the second amplifier stage is routed through a selectable bandwidth low-pass filter in order to reduce the noise floor. Sample-and-hold circuits for each chain allow simultaneous sampling of the data on all three inputs. Each sample-and-hold output is then multiplexed in turn to a 16-bit ADC. The ADC output is passed via the ISA bus interface to the System Control Board for processing. Also passed to system control is the detector calibration data held in EEPROM within the detectors.

Internal Modulation Board, AG1F

The AG1F module uses DSP and 12 bit DAC technology to generate the required modulation signals. In FM mode, user-defined low-distortion sine waves are produced and routed to AS1 to FM modulate the source core synthesiser. In pulse mode, either user-defined single pulses or pulse patterns are produced and routed to AS6 to pulse modulate the microwave source. The pulse generator can also be externally triggered by a user-defined delay.

Both FM and pulse modulation signals are also routed to the rear-panel MOD IN/OUT connector. Input and output impedances are 50 ohms to preserve the bandwidth of the modulating signals. Signal route switching is via analogue switches and is software controlled.

Pulse Modulator and Microwave Switch, AS6

The AS6 board is common for all internal pulse modulation options (Options 25a and 25b). AS6 produces regulated supply rails and control logic for the pulse modulator, microwave transfer switch and 20 dB amplifier modules.

Fast logic circuitry is used to interface fast modulation pulses to the pulse modulator module. Modulation pulses are supplied to AS6 from either an external or internal source. An FM modulating sine wave is 'looped through' AS6 if pulse modulation is not selected. Four LEDs show the hardware state.

The pulse modulator module is an absorptive pin diode switch, capable of pulse-modulating the microwave source with good isolation and very fast edges. The microwave transfer switch is a low loss electromechanical switch. Its function is to route the microwave source through the pulse modulator when pulse mode is selected.

Spectrum analyzer

Input Distribution Block

The input RF signal is directed by the SP2T PIN diode switch to either the reflection mixer for signals up to 4.2 GHz, or the harmonic mixer for signals between 4.2 and 24 GHz. The local oscillator signal for both mixers is supplied by the 1st LO Block. The LO for the reflection mixer needs to be higher in frequency than the highest frequency to be analyzed, in order to give the required frequency coverage and to avoid image responses.

The reflection mixer converts signals of up to 4.2 GHz to an IF of 4.9593 GHz. The signal enters the input/output port of the mixer via the directional filter, where it is mixed with the LO (operating over the range 4.9593 - 9.1593 GHz) and is reflected out from the same port. The reflected signal passes through the directional filter, which allows through the signal at the required IF frequency but removes unwanted components.

1st LO Block and SA Synthesiser Board, AR4

The first LO signal is provided by a 4.5 - 9.2 GHz YIG oscillator. The LO frequency is phase-locked to the 400 - 450 MHz synthesizer on the SA Synthesiser Board, AR4. This uses a programmable divider that utilises the IFR patented fractional-N architecture. The LO signal is sampled by the sampling gate; and is phase-locked to one quarter of the synthesizer VCO frequency (100 - 112.5 MHz). The drive for the sampling gate is derived from the synthesizer VCO output. The voltage output from the phase detector is fed via the loop filter to the FM coil driver on the Sweep Control Board, AR3. This in turn is used to provide fine frequency adjustment of the YIG oscillator frequency (± 50 MHz). The AR3 board also provides the YIG main coil tuning control voltage which, via AR11 board, is used for coarse frequency control over the range 4.5 - 9.2 GHz.

The SP3T PIN diode switch in the 1st LO Block directs the 4.5 - 9.2 GHz LO signal to either the reflection mixer, harmonic mixer or an external millimetric mixer (if connected).

Harmonic mixer

To provide coverage to 24 GHz without the need for a high frequency local oscillator a harmonic mixer is used. The 4.5 - 9.2 GHz local oscillator is again used, but the input signal is now mixed with harmonics of the local oscillator frequency. However, the input signal will not only mix with each of the harmonics of the local oscillator to produce a response, but will also show additional responses at image frequencies (these unwanted image responses are offset in frequency by twice the IF). To overcome this problem, a tracking band-pass filter is used at the mixer input (YIG pre-select filter). The tuned frequency of the YIG filter changes synchronously with the local oscillator frequency, so that the filter is always tuned to the set frequency.

Sweep Control Board, AR3

The Sweep Control Board, AR3 generates control signals for:

- Main coil of the YIG oscillator in the First LO Block (frequency tuning control).

- FM coil of the YIG oscillator (phase locking).

- YIG pre-selector filter tuning.

- Selection of the harmonic that the harmonic mixer is to operate on.

- SP2T switch in the Up-Converter Block.

- SP3T switch in the First LO Block.

- Step attenuator.

Spectrum Analyzer Interface Board, AR11

This board distributes the control signals generated on AR3 to the various blocks on the microwave chassis (for simplicity these are not shown on the block diagram). It also converts the control signals for the YIG oscillator main coil (on the 1st LO Block) and the YIG pre-selector filter into the necessary tuning control drives.

Down-Converter Block

The Down-Converter Block takes the up-converted signal at 4.9593 GHz and translates it to an IF frequency of 479.3 MHz by mixing it with the output from a local oscillator. The dielectric resonant oscillator (DRO) operates at 4.48 GHz and is phase-locked to the 10 MHz reference frequency. A coupler provides a sample of the oscillator output which is divided by four to give 1.12 GHz, and is used for phase-locking the DRO. The 1.12 GHz signal is also output to the First IF System for further LO signal generation. The IF is filtered before it leaves the Down-Converter Block.

1st IF System, AR1

This is the first of the two boards that comprise the IF chain. The SP3T PIN diode switch selects the 479.3 MHz output from either the down-converter, harmonic mixer or external millimetric mixer. The selected signal is down-converted twice, first to an IF of 80.7 MHz, followed by a conversion to a final IF of 10.7 MHz. To avoid over-complicating the block diagram, the various filters for reducing unwanted signals in the IF output are not shown.

The reflection, harmonic and external mixers have different losses. To accommodate these mixer losses and in order to optimise the receiver dynamic range with varying input levels, two switched-gain amplifiers are used. The 479.3 MHz amplifier provides a gain of 0 - 30 dB in 10 dB steps; the 10.7 MHz amplifier provides a gain of 0 or 10 dB.

A UHF mixer converts the 479.3 MHz IF signal to 80.7 MHz; down-conversion to 10.7 MHz is then performed by the VHF mixer. The LO drives for the mixers are derived from the 1.12 GHz input from the Down-Converter Block. This is divided by 2 and 16 to produce the 560 MHz and 70 MHz local oscillator signals for the UHF and VHF mixers respectively.

2nd IF System, AR2

This is the second of the two boards that comprise the IF chain. The 10.7 MHz IF from the 1st IF system is passed to the input amplifier, which switches in additional gain (0, 10 or 20 dB) to adjust the reference level for maximum sensitivity. The following 10.7 MHz band-pass filters are used for determining the resolution bandwidth of the spectrum analyzer. They provide bandwidths from 1 kHz to 3 MHz in a 1, 3, 10... sequence.

The log amp / detector stage provides a DC voltage proportional to the amplitude in dB of the 10.7 MHz IF, and covers over 80 dB dynamic range. The video bandwidth filter is a low-pass filter with selectable video bandwidths of 1 Hz to 100 kHz in a 1, 3, 10... sequence. It reduces high frequency noise on the detected signal, enabling low level signals to be identified that would otherwise be buried in noise. The video filter output is converted to 12-bit digital data and output to the System PC Board via the ISA bus for processing and display.

The FM demodulator enables the modulating waveform of a narrowband FM modulated signal to be displayed as frequency deviation versus time. The demodulated signal can be routed to the audio amplifier, which drives an internal loudspeaker.

Power supply

The power supply is a switched-mode unit that runs directly from the AC supply. The unit can accept AC voltages in the range 90 V - 265 V at a frequency of 45 Hz to 65 Hz. It supplies DC voltages of +5 V, +6.5 V, +21.5 V, +24 V and ± 18 V.

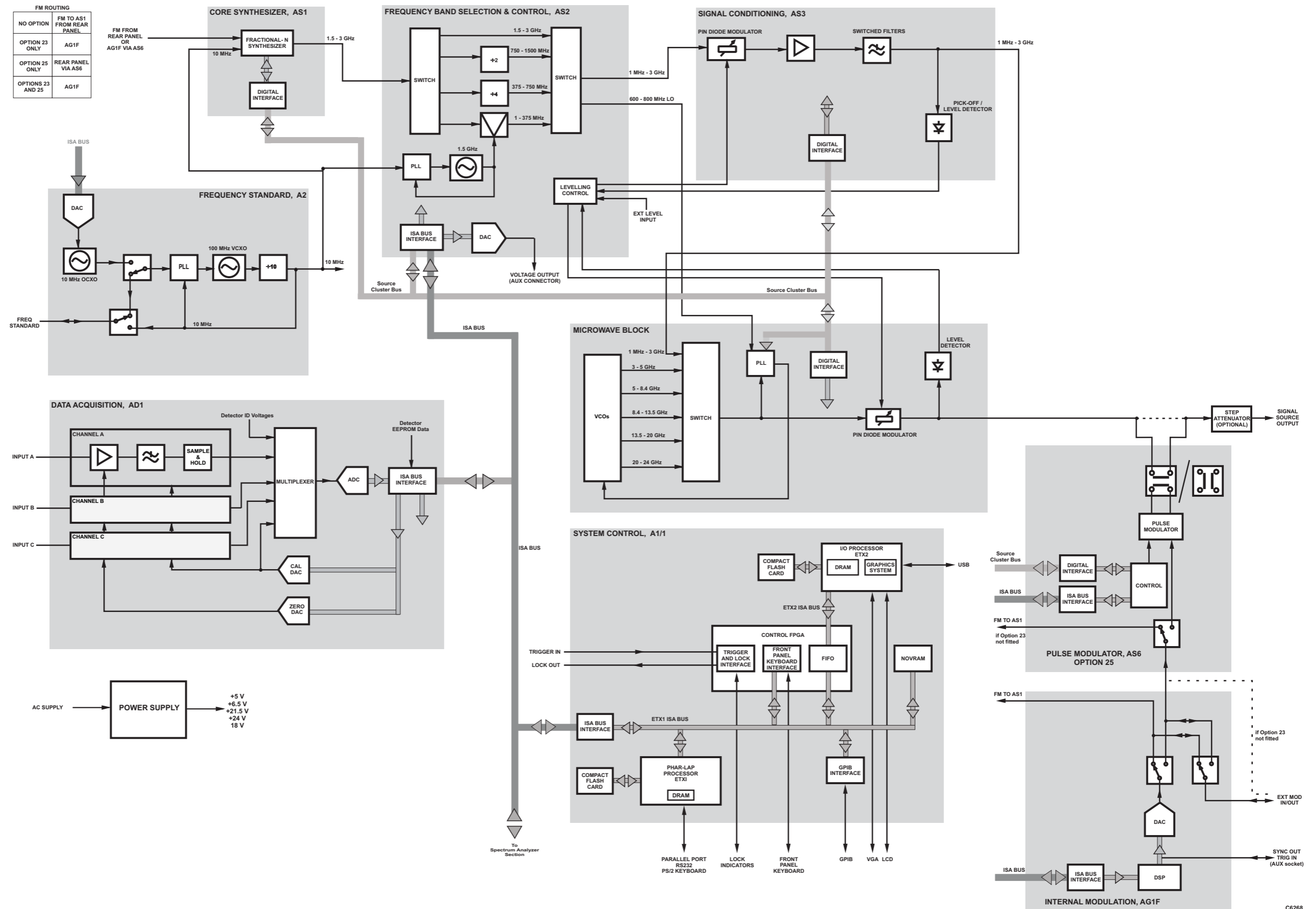
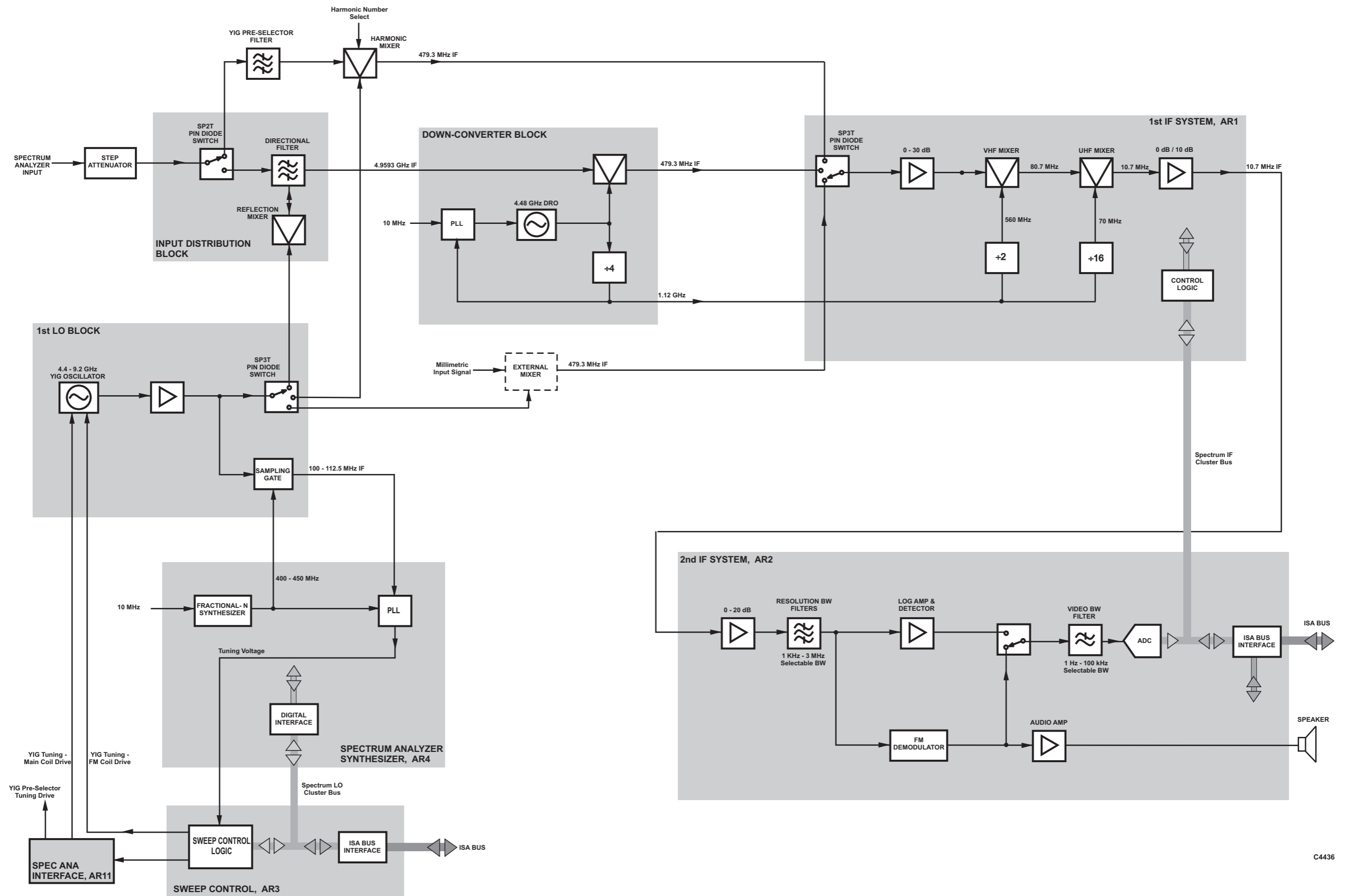

Fig. 4-1 System block diagram (sheet 1)

System block diagram (sheet 1)



C4436

Fig. 4-2 System block diagram (sheet 2)

System block diagram (sheet 2)

Chapter 5

ACCEPTANCE TESTING

Contents

Introduction	5-1
1 Power-on and configuration check.....	5-2
2 Source power and scalar analyzer checks	5-2
3 Spectrum analyzer checks	5-3

Introduction

The following procedure is intended as a quick and convenient method for checking the basic functionality of a new instrument. For a full test of instrument performance against the published specification, refer to the 6800 Series Maintenance Manual.

EQUIPMENT REQUIRED

For all models:

Description	Minimum specification
Scalar detector	Aeroflex 6230A or 6230L Series (frequency range and connector to match signal source output of unit under test)

For models 6841A, 6843A, 6844A - as above plus:

Link cable	43139/051 (N-type) or 43139/052 (3.5 mm) or similar low loss cable to link signal source output to spectrum analyzer input
------------	--

For models 6842A, 6846A, 6847A, 6848A - as above plus:

Microwave signal source	Minimum frequency 4 GHz, maximum frequency to match spectrum analyzer input range of unit under test Output level -5 dBm
Microwave cable assembly	Flexible cable to connect signal source to unit under test, connectors to match unit under test

1 Power-on and configuration check

- (1) Connect an AC supply lead to the input connector on the rear panel and set the supply switch to the '1' position. Check on the front panel that the yellow LED adjacent to the SUPPLY switch is lit, indicating standby power is present.
- (2) Press the SUPPLY switch on the front panel. As the instrument performs its power-on self tests, check that no errors are reported ¹.
- (3) Press the [UTILITY] key, then the [Service], [Status] and [Display Build State] soft keys. Check that the model and serial numbers are correctly reported and the frequency range(s) and hardware options correspond to the expected hardware configuration of the instrument.

Note

Allow the instrument to warm up for a minimum of 30 min before continuing with the following tests.

2 Source power and scalar analyzer checks

Input A

- (1) Connect 6230A/L series detector to Input A and to the SIGNAL SOURCE OUTPUT.
- (2) Press the [PRESET] key, then the [Full] soft key.
- (3) If the unit under test is a 6840A series, press [SCALAR], then [Yes].
- (4) Set the reference level to +20 dBm and the scaling to 5 dB per division as follows:

```
[SCALE/FORMAT]
[Set Scale...]
[5] [ENTER/=MKR]
[Set Ref Level...]
[2] [0] [ENTER/=MKR]

[SCALAR]
[Averaging]
```

- (5) Zero the detector by pressing [CAL] [Zero Detectors]
- (6) Set the frequency range to stop at 3 GHz by pressing:

```
[SOURCE]
[Set Stop Frequency...]
[3] [G n]
```

- (7) Turn on the source output by pressing [SOURCE ON/OFF] and check that the output level appears as an approximately flat trace four divisions below the top of the graticule area.

Check that the "UNLEV" and "UNLOC" indicators do not appear in the general information area of the display.

- (8) Use the active marker to find the points of minimum and maximum output power as follows:

```
[MARKER]
[Active Mkr to Minimum]
and
[Active Mkr to Maximum]
```

Observing the marker readout in the trace information area, check that the peak to peak difference between the minimum and maximum power does not exceed 0.9 dB (± 0.7 dB internal levelling accuracy ± 0.2 dB detector frequency response).

¹ If a power on self test error has occurred, press the [UTILITY] key, then the [Service], [Status] and [Display Test Results] soft keys for further details. Obtain a hard copy of the power on test results if necessary using the print function. Contact Aeroflex for further assistance.

- (9) Increase the source output level to maximum by pressing:

[SOURCE]
[Set Output Power...]
[1] [0] [ENTER/=MKR] on standard units *, or
[8] [ENTER/=MKR] on units with step attenuator options installed *

* Reduce by 0.5 dB if optional field replaceable connectors are fitted.

Check that the output has increased to the correct level and that the “UNLEV” indicator does not appear in the general information area of the display.

For models 6821A, 6841A and 6848A skip to step (13)

- (10) Set the frequency range to start at 3 GHz and reset the level to 0 dBm by pressing:

[SOURCE]
[Set Stop Frequency...]
Enter maximum source frequency and terminate with [G n]
[Set Start Frequency..]
[3] [G n]
[Set Output Power...]
[0] [ENTER/=MKR]

- (11) Again use the active marker to find the points of minimum and maximum output power (step (7)) and check that the peak to peak difference between the minimum and maximum power does not exceed 1.2 dB (± 1.0 dB internal levelling accuracy ± 0.2 dB detector frequency response).

- (12) Increase the source output level to maximum by pressing:

[SOURCE]
[Set Output Power...]
[5] [ENTER/=MKR] on standard units *, or
[2] [ENTER/=MKR] on units with a step attenuator option installed *

* Reduce by 0.5 dB if optional field replaceable connectors are fitted.

Check that the output has increased to the correct level and that the “UNLEV” indicator does not appear in the general information area of the display.

Inputs B and C

- (13) Repeat steps (5) to (12) with the detector connected to inputs B and C. (Select detector inputs by pressing [SCALAR] [Input Selection] [B] or [C].)
(14) Disconnect the detector.

3 Spectrum analyzer checks

- (1) Connect the link cable between the 684XA SIGNAL SOURCE OUTPUT and the SPECTRUM ANALYZER INPUT.
(2) Preset into spectrum analyzer mode by pressing [PRESET] and [Full].
(3) Set the scaling to 1 dB per division as follows:
[SCALE/FORMAT]
[Set Scale...]
[1] [ENTER/=MKR]
(4) Set the frequency range to stop at 3 GHz by pressing:
[SPECTRUM]
[Cntr/Span]
[Set Stop Frequency...]
[3] [G n]

ACCEPTANCE TESTING

- (5) Set the signal source to tracking generator mode, with an output signal of -5 dBm, by pressing

[SOURCE]
[Tracking Generator]
[Set Output Power...]
[-] [5] [ENTER/=MKR]

- (6) Check that the peak-to-peak amplitude variation of the displayed trace does not exceed 1.7 dB (± 1.0 dB amplitude accuracy ± 0.7 dB source levelling accuracy).

For models 6841A and 6848A skip to step (11)

- (7) Set the frequency range to start at 3 GHz and stop at 20 GHz, or the maximum source frequency, whichever is lower:

[SPECTRUM]
[Set Stop Frequency...]
[2] [0] [ENTER/=MKR]
(or [8] [.] [4] [ENTER/=MKR] on models 6842A and 6846A)
[Set Start Frequency...]
[3] [ENTER/=MKR]

- (8) Check that the peak-to-peak amplitude variation of the displayed trace does not exceed 5 dB (± 4 dB amplitude accuracy ± 1 dB source levelling accuracy).

For models 6842A, 6843A, 6846A and 6847A skip to step (11)

- (9) Set the frequency range to start at 20 GHz and stop at 24 GHz:

[SPECTRUM]
[Set Stop Frequency...]
[2] [4] [ENTER/=MKR]
[Set Start Frequency...]
[2] [0] [ENTER/=MKR]

- (10) Check that the peak-to-peak amplitude variation of the displayed trace does not exceed 5.5 dB (± 4.5 dB amplitude accuracy ± 1 dB source levelling accuracy).

Auto Tune check

- (11) Press [PRESET] [Full].
- (12) Set the source to the first frequency listed in Table 1 by pressing [SOURCE] [Set Frequency...], then enter the numeric value followed by [ENTER/=MKR].
- (13) Auto tune to the signal by pressing [SPECTRUM] [Auto Tune]. Check that the signal displayed is nominally correct in both frequency and power.
- (14) Repeat at the remainder of the frequencies listed in Table 1.

For all 684XA:	20 MHz, 500 MHz, 1 GHz, 3 GHz
-----------------------	-------------------------------

Table 1 Test points for auto tune check up to 3 GHz

- (15) If the unit under test is a 6842A, 6846A, 6847A or 6848A, disconnect the cable linking the SIGNAL SOURCE OUTPUT and the SPECTRUM ANALYZER INPUT and connect the external source output to the SPECTRUM ANALYZER INPUT using the microwave cable assembly. Set the output level of the external source to -5 dBm.
- (16) Repeat step (13) at each of the frequencies listed in either Table 2 or Table 3, using either the internal source of the 684XA or the external source, as appropriate.

ACCEPTANCE TESTING

For 6843A and 6844A:	4 GHz, 8 GHz, 12 GHz, 16 GHz, 20 GHz
For 6844A:	22 GHz, 24 GHz

Table 2 Test points for auto tune check above 3 GHz using internal source

For 6842A, 6847A and 6848A:	4 GHz, 8 GHz, 12 GHz, 16 GHz, 20 GHz
For 6847A:	22 GHz, 24 GHz

Table 3 Test points for auto tune check above 3 GHz using external source

Appendix A

INSTRUMENT DEFAULT SETTINGS

The default settings of the most commonly encountered instrument parameters and functions are given below. These are the settings that exist after [PRESET] [*Full*] has been pressed.

If [PRESET] [*Measurement*] is pressed, default measurement settings are applied to the current channel (both channels if channel coupling is on and both are the same type), without affecting the number of channels and measurements displayed and their types.

Parameters followed by * apply globally; these are instrument configuration settings and are not affected by PRESET (or recalling instrument settings). The default conditions apply if the data relevant to these parameters has become corrupted or lost

Parameter / function	Default value/state
<i>Channel configuration</i>	
Number of channels	1
Active channel number	1
Active channel mode	6820A series: Scalar 6840A series: Spectrum analyzer
Non-active channel mode	Scalar
Active measurement	1
Channel coupling	6820A series : ON 6840A series : OFF
<i>Source control</i>	
Source mode	Linear frequency sweep
Start frequency	Minimum
Stop frequency	Maximum
CW frequency	Minimum (Maximum/2 fo spectrum analyzer channel)
Output power	0 dBm
Start power	Minimum levelled power (with attenuator option set to minimum)
Stop power	Maximum guaranteed output power
Frequency modulation (if FM Option fitted)	OFF
Sweep time control	Auto
User set sweep time	1 s
RF on/off	OFF
Levelling mode *	Internal
Frequency standard *	Internal
Voltage output mode	Fixed
Voltage output level	0 V

INSTRUMENT DEFAULT SETTINGS

Measurement

Detector linearity correction	ON
Detector flatness correction	ON
Autozeroing	OFF
Detection mode *	DC
Input offsets	0 dB

Scalar Analyzer Channel

Source mode	Start/stop frequency sweep
Start frequency	Minimum
Stop frequency	Maximum
Power level	0 dBm
CW frequency	Minimum
Start power	-10 dBm
Stop power	+5 dBm
Number of points	401
Source of graticule X-axis annotation	Source
Measurement definition	A
Averaging	OFF
Averaging number	16
Smoothing	OFF
Path calibration	OFF
Path cal store used	Ch 1 Meas 1 : PCL1 Ch 1 Meas 2 : PCL2 Ch 2 Meas 1 : PCL3 Ch 2 Meas 2 : PCL4
Memory operation	OFF
Format	Scalar / Tuned Input : dBm Group Delay : Delay
Reference position	dB(m) : Top line VSWR : Bottom line Watts : Top line Volts : Top line Delay : Centre
Reference level	dB(m) : 0 dB(m) VSWR : 1 Watts : 100 mW Volts : 1 V Delay : 0 μ s
Scaling	dB(m) : 10 dB/div VSWR : 0.2/div Watts : 10 mW/div Volts : 0.1 V/div Delay : 2 μ s/div
Rx resolution bandwidth (tuned input mode)	3 MHz (fixed at 3 MHz for group delay)
Rx operating signal level (tuned input and group delay modes)	0 dBm

INSTRUMENT DEFAULT SETTINGS

Fault Location Channel

Entry mode	Range
Distance units *	Metres
Medium	Coax
Range	100 m
Relative velocity	1
Attenuation	0 dB / m
Windowing level	Medium
Masking correction	OFF
Measurement definition	The input to which the 6240 Series Fault Locator is connected, or input B if a Fault Locator device is not detected.
Number of points	401

Spectrum Analyzer Channel

Source of graticule frequency annotation	Spectrum analyzer receiver
Receiver start frequency	10 MHz
Receiver stop frequency	Maximum
Reference level	<i>dBm</i> : 0 dBm <i>dBμV</i> : 107 dB μ V <i>Volts</i> : 10 V
Resolution BW	Formula driven
Video BW	Formula driven
Input attenuator setting	10 dB
Sweep time	Formula driven
Tracking generator (source) power level	0 dBm
Tracking generator offset	0
Tracking generator scaling	1
Scaling	<i>Spectrum analyzer</i> : 10 dB / div <i>FM demodulation</i> : 2 kHz / div
Signal tracking	OFF
Demodulation	OFF

General

Screen title	ON
Measurement titles	OFF
Language *	UK English
Keyboard layout *	UK
Date format *	03 Jan 2008
Spreadsheet field separator *	,
Decimal point *	.
LCD backlight *	Maximum
LCD colour palette *	Colour

INSTRUMENT DEFAULT SETTINGS

Active marker assignment	Marker 1
Delta marker	OFF
Marker table	OFF
'Secret' function (freq annotation removed)	OFF
Limit checking	OFF
Hard copy device	HP DeskJet / LaserJet
Hard copy port assignment	<i>Printer :</i> USB
Hard copy options	All options enabled (except marker table)

Appendix B

ERROR MESSAGES

This Appendix lists in alphabetical order all the errors that can be reported to the user via the display. The errors are grouped as follows:



System Error. This usually implies a hardware fault or corruption of data in a non-volatile store (page App B-2).



Instrument Warning. This is a warning to the user that the instrument is being used incorrectly (page App B-5).



C0278

Data Warning. This is a warning that the data that has been input is inappropriate (page App B-13).

An icon as shown above will be displayed on the screen to inform the user of the type of error that has been detected.

System error

A printer driver failed to load

A printer driver failed to load at power on. Try re-installing the printer driver.

Refer to the Maintenance Manual if the problem persists, or contact Customer Support (address at rear of manual).

Detector EEPROM data corrupted:

Input: *<input identifier>*

<block type> **Block**

Data stored in the detector EEPROM connected to the specified input has been found to be corrupt. Additional information relating to the specific block of data affected is provided for reference (Identity, Linearity or Flatness). The instrument will continue to make measurements using the affected detector but, because default correction data will be used, measurement accuracy will be affected.

Error detected while loading language files

An error was detected while loading language files. This may mean that a problem occurred when the language was being installed or that the files were found to be incompatible with the installed release of the instrument software. If this error occurs the instrument will revert to UK English.

Error reading or writing an ID ROM

An error occurred while reading or writing an ID ROM on one of the instrument modules, indicating a possible hardware fault.

Refer to the Maintenance Manual if the problem persists, or contact Customer Support (address at rear of manual).

Error Strings File out of date

The 'Error Strings File' has been found to be out of date for the installed version of the instrument's software. The instrument will continue to function, but some error messages may not be displayed. To ensure correct operation, an up-to-date 'Error Strings File' should be installed.

Refer to 'Installing software upgrades' in the 6800A Operating Manual.

Failed to read the temperature of the spectrum analyser receiver

An attempt to read the AR2 (2nd IF System) temperature sensor via the I²C bus failed. The instrument will continue to operate but the accuracy of spectrum analyser measurements may be affected.

A printer driver failed to load

A printer driver failed to load at power on. Try re-installing the printer driver.

Refer to the Maintenance Manual if the problem persists, or contact Customer Support (address at rear of manual).

Failed to save calibration data

A failure occurred when the system was attempting to write calibration data to an internal store. The most likely reason is that there is insufficient free space on the instrument's flash card.

Additional space should be created by using the Store Management function (accessed via the [UTILITY] key) to delete unwanted files. The Store Management function may be used to transfer files to removable storage for safekeeping before they are deleted.

Frequency standard calibration failure

An error has occurred during a frequency standard calibration.

Refer to the Maintenance Manual if the problem persists, or contact Customer Support (address at rear of manual).

General Strings File out of date

The 'General Strings File' has been found to be out of date for the installed version of the instrument's software. The instrument will continue to function, but some messages may not be displayed. To ensure correct operation, an up-to-date 'General Strings File' should be installed.

Refer to 'Installing software upgrades' in the 6800A Operating Manual.

IDROM checksum failure

A checksum failure was detected when reading the ID ROM on one of the instrument modules.

Refer to the Maintenance Manual if the problem persists, or contact Customer Support (address at rear of manual).

Resolution Bandwidth Filter calibration failed

A measurement timeout occurred during the resolution bandwidth filter calibration. The most likely cause is a fault in the receiver measurement sequencer.

Refer to the Maintenance Manual if the problem persists, or contact Customer Support (address at rear of manual).

Scalar analyser ADC or calibration DAC failure

During calibration of the scalar analyser amplifiers it was found that the ADC was not responding to changes in the calibration DAC value.

Refer to the Maintenance Manual if the problem persists, or contact Customer Support (address at rear of manual).

Scalar analyser sequencer timed out

Following the initiation of a data acquisition sequence, no processor interrupt was received within the expected period.

Refer to the Maintenance Manual if the problem persists, or contact Customer Support (address at rear of manual).

Scalar data acquisition amplifier calibration failure:

Input: <input identifier>

Range: <range>

The amplifier calibration has failed or given unexpected results. Details of the input and range are provided for reference. Note that only the first error encountered during a calibration is reported.

Refer to the Maintenance Manual if the problem persists, or contact Customer Support (address at rear of manual).

Software upgrade failed

A problem has occurred while attempting to upgrade the instrument software. The specific failure is identified by the error code number.

In the unlikely event of this error occurring, contact Customer Support (address at rear of manual).

Source FM calibration failure

The source FM calibration has failed, indicating a possible hardware fault.

Refer to the Maintenance Manual if the problem persists, or contact Customer Support (address at rear of manual).

Source frequency calibration failure

An error has occurred during a source frequency calibration.

Refer to the Maintenance Manual if the problem persists, or contact Customer Support (address at rear of manual).

Source power calibration failure

An error has occurred during a source power calibration.

Refer to the Maintenance Manual if the problem persists, or contact Customer Support (address at rear of manual).

Spectrum analyser calibration failure

An error has occurred during a spectrum analyser calibration.

Refer to the Maintenance Manual if the problem persists, or contact Customer Support (address at rear of manual).

Spectrum analyser calibration failure: No signal

The spectrum analyzer calibration cannot proceed because an RF signal was not detected at the spectrum analyzer input. The most likely reason is that the source was not connected to the spectrum analyzer input before starting the calibration.

Spectrum analyzer LO calibration failure

Lock not found at <frequency> kHz

The spectrum analyzer local oscillator calibration failed as a result of a failure to find a lock at the specified frequency.

Refer to the Maintenance Manual if the problem persists, or contact Customer Support (address at rear of manual).

Store corrupted

The specified store (whether internal or on removable storage) has been found to be corrupted. If the store is required for the operation of the instrument, it will be repaired by overwriting with default data.

Refer to the Maintenance Manual if the problem persists, or contact Customer Support (address at rear of manual).

The detector connected to input <input identifier> failed to zero

The instrument failed to zero the detector connected to the specified input (A, B or C).

Ensure that RF power is not applied to the detector during the zero operation (the source within the instrument itself is switched off automatically while a zero is in progress).

This operation requires the FM option

Remote control error. The operation requested is unavailable because the FM option is not present.

This operation requires the Group Delay option

Remote control error. The operation requested is unavailable because the Group Delay option is not present.

YIG Preselector Filter calibration failed

DAC under-range at <frequency> kHz

The spectrum analyzer YIG Preselector Filter calibration failed as a result of a DAC under-range error at the specified frequency.

Refer to the Maintenance Manual if the problem persists, or contact Customer Support (address at rear of manual).

YIG Preselector Filter calibration failed

Measurement timed out at <frequency> kHz

The spectrum analyzer YIG Preselector Filter calibration failed as a result of a measurement timeout at the specified frequency.

Refer to the Maintenance Manual if the problem persists, or contact Customer Support (address at rear of manual).

Instrument warning

A limit specification may contain no more than twelve limit segments

Remote control error. A limit specification was defined with too many limit segments; the maximum number is 12.

A path calibration must be selected before it can be turned on

Remote control error. A path calibration store must be selected before issuing the command to turn it on.

Use the SCALar:PCAL:SElect command to select a path calibration for use with the measurement.

Active marker not enabled

The requested marker function cannot be carried out because the active marker is not enabled.

Enable the active marker using the MARKer:ACTive ON command.

Application <application name> not found

Remote control error. The application referred to in a remote control command was not found.

Assign limit specification to the active measurement

An attempt was made to enable limit checking when no limit specification has been assigned to the measurement.

Autorun application <application name> not found

The application set to run automatically following power on was not found.

Cannot abort. No printing in progress

A request to abort a print has been requested when there is no print in progress.

Cannot complete short / open calibration

Remote control error. This error can occur when performing an open/short calibration via the remote control interface. A command is used to save the measurement of one of the calibration pieces to a path calibration store. A separate command is then used to average the measurement of the other calibration piece into the same store. The error message is displayed if the averaging cannot be performed because the store does not contain the expected data. Likely causes are that the specified store does not contain the measurement of the first calibration piece, or the instrument set-up (e.g. number of measurement points) has changed between storing the measurement of the first and second calibration pieces.

Cannot find language files on floppy disk

The relevant files could not be found on the removable storage during the installation of a new language.

Cannot find the specified keyboard layout file

Remote control error. Cannot find the specified keyboard layout file. The most probable cause is mis-typing the file name.

Cannot find the specified printer driver

Remote control error. A request to remove a printer driver file could not be actioned because the specified printer driver could not be found

Cannot 'hold' a trace displaying a memory

Remote control error. The 'Hold' function only applies to live measurements; a trace that is displaying a stored measurement cannot be held.

Cannot measure bandwidth

Remote control error. A bandwidth measurement cannot be made unless the trace is displayed in log format.

Cannot measure noise in 1 Hz bandwidth

A measurement of the noise in a 1 Hz bandwidth cannot be performed on a normalised spectrum analyzer trace.

Cannot recall settings

The settings were stored on an instrument containing group delay option

An attempt was made to recall settings that were stored on a 684X variant with Group Delay option present on a 684X variant without the option.

Cannot recall settings

The settings were stored on an instrument containing a spectrum analyser

An attempt was made to recall settings on a 682X variant that were originally stored on a 684X variant.

Cannot reinstall an old software release

An attempt was made to restore a release of the software that is older than that currently installed. This is not allowed because it is possible that the software may be incompatible with newer system files present on the instrument's flash card.

If the attempt at re-installing the software is the result of a suspected software problem, contact Customer Support for advice (address at rear of manual).

Cannot remove built-in standard applications

An attempt was made to delete one of the standard built-in applications, which is not allowed.

Cannot remove country support

Remote control error. An attempt to remove country support using SYSTEM:ISettings:COUNTRY:REMove failed because the specified country settings are currently in use.

Cannot remove keyboard driver

Remote control error. An attempt to remove a keyboard driver using SYSTEM:ISettings:KEYBoard:REMove failed because the specified keyboard driver is currently in use.

Cannot remove language support

Remote control error. An attempt to remove language support using SYSTEM:ISettings:LANGUage:REMove failed because the specified language is currently in use.

Cannot remove printer driver

The specified printer driver cannot be deleted as it is currently in use.

Cannot remove standard built-in printer driver

An attempt was made to delete the standard built-in printer driver, which is not allowed.

Cannot run application

An attempt was made to run an application while another is already executing.

Cannot select source power calibration

When a source power calibration file is selected for use, the instrument checks to ensure that the frequency range covered by the calibration is available from the source. If that is not the case, this error message is displayed. The only reason why this error might occur is if the calibration file was created on a different variant of the instrument and transferred via the remote control interface or removable storage, so that the frequency range of the calibration exceeds that of the source.

Cannot select specified language

Remote control error. An attempt has been made to select a language that has not previously been installed.

Cannot send print data to another file

A file containing print data that was generated earlier can only be directed to the USB or parallel ports, but not a another file.

Cannot set range or centre frequency when in Frequency Entry Mode

Remote control error. An attempt was made to set the fault location range or centre frequency in a fault location channel configured for start / stop frequency entry.

Cannot set source start or stop frequencies when in Range Entry Mode

Remote control error. An attempt was made to set the source start or stop frequency in a fault location channel configured for Range entry.

Cannot set the Primary Password

Setting the Primary Password is not allowed.

Cannot set the waveguide cut-off frequency while the transmission line medium is coax

An attempt was made to set the waveguide cut-off frequency while the transmission line medium was set to coax; this parameter only applies to waveguides.

Cannot transfer data to specified store

Remote control error. This error can occur when transferring the contents of a store to the instrument via the remote control interface if the number of data bytes transferred is fewer than expected for the store type.

Cannot transfer narrowband source power calibration to Primary

Source power calibrations over a narrower frequency range than the source is capable of providing may not be transferred to the primary calibration.

Set the Primary power calibration to cover the full frequency range of the source.

Cannot use the GPIB port to control an external device

Remote control error. The GPIB port has previously been set up as a talker / listener for remote control by another computer, so may not be used for controlling an external source.

Change the setting to 'Controlled by RS232' or 'No External Controller' to allow the GPIB port to take control of external devices.

Channel coupling not allowed

Channels can only be coupled when they share the same mode

Remote control error. Channels can only be coupled when they are of the same type (i.e. both channels must be either scalar, fault location or spectrum analyzer).

Channel coupling not allowed

Ensure channels have at least 401 measurement points for channel coupling operation

The number of measurement points must be greater than 401 on both channels if Tuned Input or Group Delay is in use.

Command not allowed while displaying a demodulated waveform

Remote control error. An illegal command was received while the measurement was a demodulated waveform.

Command only applicable to spectrum analyser models

Remote control error. A command specific to spectrum analysers has been received by an instrument that does not contain a spectrum analyser.

Corrupted 2031 external source driver

An invalid 2031 external source store was detected. Parsing of the store detected an error condition.

Try re-installing the 2031 external source driver.

Delta marker not enabled

Remote control error. The requested marker function cannot be carried out because the delta marker is not enabled.

Enable the delta marker using the MARKer:DELTA ON command.

Demodulation must be enabled before this command can be accepted

Remote control error. The command is not allowed unless demodulation is enabled.
To show a demodulated signal use the `SANalyzer:DEModulation:DISPlay` command.

Disabling external mixer mode

The external mixer is disabled when entering tracking generator mode if the instrument is either a 6841 or 6848 variant.

Disk full or missing

The operation could not be completed because the internal memory is full or, in the case of removable storage, not present in the USB port. Delete or move stores to make room for the new item.

External source driver is corrupt

An invalid external source store was detected. Parsing of the store detected an error condition.
Try re-installing the appropriate external source driver.

External source not found on gpib interface

An external source was not detected on the remote interface.
Check speed and/or address settings and cable connections.

File or directory not found

The required file or directory is not present, either internally or on removable storage (or the USB port is empty).

Files not found on floppy disk

Remote control error. Unable to install the specified country files. The relevant files are not present on the removable storage device used for installation.

Floppy disk has changed

The removable storage has changed since selecting the path in the Store Management function.

Format is incompatible with the channel mode

Remote control error. The requested display format is incompatible with the channel mode. For example, Watts format has been requested for a fault location measurement.

Format is incompatible with the measurement definition

Remote control error. The requested display format is incompatible with the current measurement. For example, Watts format has been requested for a scalar ratio measurement such as A/C.

Incorrect disk

During a software upgrade a removable storage device was inserted that was out of sequence or does not belong to the upgrade set.

Replace the device with the correct one and press the *[Continue]* key.

Instrument has failed to communicate with an external device

Remote control error. The instrument has failed to communicate with an external device.
Check speed and/or address settings (using `[UTILITY][Remote]`) and cable connections.

Insufficient free space to perform software upgrade

The software upgrade cannot be performed because there is insufficient free space on the instrument's flash card.

Additional space should be created by using the Store Management function (accessed via the [UTILITY] key) to delete unwanted files. The Store Management function may be used to transfer files to removable storage for safe keeping before they are deleted.

Invalid filename for path calibration

An invalid filename has been specified to hold a path calibration. Valid filenames are PCL1, PCL2, PCL3 or PCL4.

Live Y voltage output is not available in Source Only Mode

The 'Live Y' voltage output is not available when in source-only mode. The voltage output mode has been switched to Constant Voltage.

Measurement data invalid

An operation such as hold, save trace to memory or print has been initiated before the whole trace contains valid data. The operation is ignored.

Wait until the measurement update has completed.

No external source selected

No external source has been selected for calibration or mixer measurements.

Select the appropriate external source.

Numeric keys not available

The front panel numeric keys cannot be used to set the value of the parameter currently enabled for numeric entry.

Operation is incompatible with the channel mode

Remote control error. Although the MMI does not allow illegal channel operations (such as performing an open / short path calibration on a fault location channel), there is nothing to prevent illegal remote control commands from being received.

Operation not permitted when in source-only mode

Remote control error. Many operations, particularly those involving measurements, are not permitted while the instrument is in source-only mode.

Operation not permitted when the Transmission Line Database is in use

An attempt has been made to change the medium, waveguide cut-off frequency, relative velocity or attenuation while the Transmission Line Database is in use. When the database is in use, the values of these parameters are set automatically when a particular cable or waveguide is selected.

Operation not permitted while calibration is in progress

Remote control error. An illegal command has been received while an instrument calibration is in progress.

Operation not permitted with this display format

Remote control error. The requested marker operation requires the measurement to be displayed in log format.

Operation only valid for Group Delay measurements.

Remote control error. Changing a group delay parameter requires the measurement to be a group delay measurement.

Password protected

The requested operation is not allowed because the store is password protected.

Path calibration incompatible with the measurement definition

An attempt has been made to assign a scalar analyzer path calibration to a scalar analyzer group delay measurement, or vice versa.

Printer busy

An attempt has been made to start a new print before the previous print has completed.

Query DEADLOCKED

Remote control error. Indicates that a condition causing a DEADLOCKED Query error occurred (see IEEE 488.2). This can occur if the input buffer and output buffer are full and the device cannot continue.

Query INTERRUPTED

Remote control error. Indicates that a condition causing an INTERRUPTED Query error occurred (see IEEE 488.2). This could occur, for example, if the instrument receives a data byte or a GET before it has completed sending a response to a previous command.

Query UNTERMINATED

Remote control error. Indicates that a condition causing an UNTERMINATED Query error occurred (see IEEE 488.2). The instrument may have been addressed to talk before it had received a complete program message.

Query UNTERMINATED after indefinite response

Remote control error. Indicates that a query was received in the same program message after a query requesting an indefinite response was executed (see IEEE 488.2).

Rotary control not available

The front panel rotary control cannot be used to adjust the value of the parameter currently enabled for numeric input.

Settings conflict

Remote control error. Generic error indicating that an attempt has been made to make a change that is incompatible with the current instrument state. Usually errors of this sort are filtered by the MMI, but they can occur under remote control.

See the Remote Operating Manual for restrictions on command usage.

Source power calibration requires a detector type 6230A to be connected to input A

Source power calibration requires the use of a calibrated detector, i.e. an EEPROM model such as the 6230A.

Specified hard copy device driver not found

Remote control error. The hard copy device specified in a HARDcopy:DEvice:SElect command could not be found. The string specifying the device driver to load should be one of those returned by HARDcopy:DEvice:LIST?.

Step keys not available

The front panel step keys cannot be used to adjust the value of the parameter currently enabled for numeric input.

The current set-up is incompatible with a dB/octave or dB/decade display.

Remote control error. The current set-up is incompatible with a dB/octave or dB/decade display. Check that the set-up conforms to the following settings:
Swept frequency measurement with Start < Stop
Log format
Delta Marker off

The detected source is different to the selected external source

The synthesizer on the remote interface does not match the currently selected synthesizer. Select the correct external source.

The disk is not the first in the upgrade set

This error can occur during a software upgrade.
Replace the removable storage with the first one of the set and press the [Continue] key.

The floppy disk is write protected

The removable storage is write protected, so that data cannot be written to it. To enable writes to the device, remove it and change to write enable setting.

The printer driver has timed out

Communication with the printer has timed out. (For example the printer cable has become disconnected or the printer is off line or out of paper.)

The printer driver is incompatible with the <port> port

The printer driver is incompatible with the specified port (USB or parallel).

The printer is signalling Not Ready

The printer has returned a "not ready" error status. Check that it is not off-line or out of paper.

The selected printer driver cannot handle graphics

This error is generated when graphical output has been requested but the currently selected printer driver cannot output graphics.

The selected printer driver cannot handle text

This error is generated when text output has been requested but the currently selected printer driver cannot output text. (For example, a pen plotter would not be suitable for printing tabular data.)

Too many copies

Too many copies have been requested from the hard copy device.

Trace memory contents incompatible with the channel domain

An attempt has been made to display a trace memory on a channel having the same mode but a different domain from that which was stored with the trace data. A swept frequency measurement, for example, cannot be displayed in a channel set up for swept power measurements.

Ensure the channel domain matches that of the trace memory.

Trace memory contents incompatible with the channel mode

An attempt has been made to display a trace memory on a channel having a different mode from that which was stored with the trace data. For example, a spectrum analyser trace memory cannot be displayed in a scalar analyser channel.

Unable to enter external mixer mode

An external mixer cannot be used when the Tracking Generator is in use if the instrument is either a 6841 or 6848 variant.

Unable to identify detector on input <input identifier>

The instrument has failed to recognise the detector connected to one of the scalar inputs (A, B or C).

Default correction will be used, which may affect the accuracy of the measurement.

Unable to normalise a memory display

Remote control error. Normalisation requires a live spectrum analyser measurement. A memory display cannot be normalised.

Unable to normalise spectrum analyser trace

Remote control error. It is not possible to normalise a spectrum analyser trace if the receiver is offset from the tracking generator.

Unable to read calibration data from the detector on input <input identifier>

An attempt to read the EEPROM in the detector connected to the specified input (A, B or C) failed. The most likely explanation is that the detector has not been connected properly.

Check the connection.

Unable to save trace to a trace memory

An attempt has been made to store a 'memory only' trace to a trace memory. Only 'live' measurements can be saved to trace memories.

Data warning

Block data error

Remote control error. General block data error that is reported if the instrument is unable to detect a more specific error.

Block data not allowed

Remote control error. A legal block data element was encountered but was not allowed by the instrument at this point.

Cannot interpolate path calibration or memory

This message may be displayed when a path calibration is in use or a measurement is being made relative to a previously saved trace memory. It alerts the user to the fact that the source setup has changed so that at least part of the measurement lies outside the range of the calibration data or trace memory. PC? is displayed in the trace information area as a permanent warning that the calibration may be invalid.

Character data not allowed

Remote control error. Character data was received but is not allowed by the instrument at this point.

Command header error

Remote control error. An error was detected in the header. This error is displayed when the instrument cannot detect more specific errors.

Data out of range

Remote control error. A program data element was received that could not be executed because it was outside the range allowed by the instrument.

Delta marker not enabled

The [ENTER / =MKR] front panel key was used to try to set the value of the parameter currently enabled for numeric entry but the delta marker was not switched on.

Framing error in program message

Remote control error. A framing error was detected in the program message.

Check that the serial port speed settings for the instrument and the sending device match. To check the instrument's serial port settings use [UTILITY] [*Remote*] [*Set Up RS232*].

Frequency limits for narrowband power calibration out of range

Remote control error. The upper and lower frequency limits supplied for a narrowband power calibration exceed the frequency range of the source.

GET (Group Execute Trigger) not allowed within a program message

Remote control error. A Group Execute Trigger was received within a program message which is not allowed.

Incorrect password

The password that has been entered is incorrect.

Input buffer overrun

Remote control error. An input buffer overrun has occurred while receiving from the serial controller.

Ensure that the flow control settings for the instrument and the sending device match. To check the instrument's flow control settings use [UTILITY] [*Remote*] [*Set Up RS232*].

Interpolating path calibration or memory

This message may be displayed when a path calibration is in use or a measurement is being made relative to a previously saved trace memory. It alerts the user to the fact that the source is now sweeping over a sub-range of the frequency or power range that was in use when the calibration or trace memory was saved and, as a consequence, the calibration or memory values are being interpolated.

Invalid character

Remote control error. Indicates that a character (including a line feed or EOI terminators) in a remote control command has been found where it is not allowed.

Check the command for invalid characters. Ensure that the command has been properly terminated.

Invalid character data

Remote control error. Either the character data element is syntactically incorrect or the element received is not valid for the header.

Invalid character in number

Remote control error. An invalid character was found in a number.

Invalid date

An invalid date was entered. This could result from attempting to set the month to a number greater than 12, entering an invalid day for the month (for example February 31), or entering a year before 1980 or after 2099.

Invalid directory

Remote control error. A remote control command has specified an invalid directory.

Invalid drive specifier

Remote control error. A remote control command has included an invalid drive specifier (i.e. other than A: or C:).

Valid drives are A: or C:

Invalid expression

Remote control error. The expression data element was invalid.

Invalid separator

Remote control error. A separator character in a remote control command was expected but an illegal character was received. For example, the semicolon was omitted after a program message unit.

Invalid string data

Remote control error. Invalid string data was encountered. For example an END message was received before the terminating quote character.

Ensure that the string data is terminated correctly..

Invalid suffix

Remote control error. The suffix does not follow the correct syntax, or is invalid for this instrument, or is inappropriate in the current context (for example, setting the source start to 10 MHz when the source is set up for swept power measurements).

Invalid time

An invalid time was entered.

Missing parameter

Remote control error. Fewer parameters were received than required for the header.

Numeric data error

Remote control error. A problem has been detected with data that appears to be numeric. This error is displayed when the instrument is unable to detect more specific errors.

Numeric data not allowed

Remote control error. A legal numeric data element was received but the instrument does not accept one in this position.

Parameter not allowed

Remote control error. More parameters were received than required for the header.

Parity error in program message

Remote control error. A parity error was detected in the program message.

Password out of range

An out of range value was entered when attempting to set up a user-defined password. Valid ranges for passwords are:

Level 1: 1000 to 9999 Level 2: 100000 to 999999

Security: 100000000 to 999999999

Passwords do not match

The value entered to confirm a password change was not the same as the value originally entered.

Program mnemonic too long

Remote control error. The header contains more than twelve characters.

Selection criteria match more than one database entry

Remote control error. The information supplied has matched more than one entry in the transmission line database.

The search criteria (manufacturer and/or transmission line type) must be narrowed to match a single entry.

Special form numeric parameter not allowed

Remote control error. A 'special form' numeric parameter (i.e. MINimum, MAXimum, UP, DOWN or MARKer) was received and was incompatible with the command.

String data not allowed

Remote control error. A string data element was encountered but was not allowed by the instrument at this point.

Stop is less than Start in segment <segment number>

The Stop value cannot be less than the Start value in a segment within a limit specification..

Suffix not allowed

Remote control error. A suffix was encountered after a numeric element that does not allow suffixes.

Suffix too long

Remote control error. The suffix contained more than twelve characters.

The supplied country string was not recognised

Remote control error. The country string supplied to a remote control command was not recognised.

Use `SYSTem:ISETtings:COUNtry:LIST?` to obtain a list of valid strings.

The supplied language string was not recognised

Remote control error. The language string supplied to a remote control command was not recognised.

Use `SYSTem:ISETtings:LANGuage:LIST?` to obtain a list of valid strings.

Transmission line not found in database

Remote control error. The specified transmission line could not be found in the transmission line database.

Tuned input frequency range clipped

The current source frequency range with offset and scaling applied would take the tuned input outside its specified operating range. The displayed range has therefore been clipped.

Unable to set parameter from marker reading

The reading at the active marker position could not be used to set the value of a parameter. The most likely reason is that the measurement at the marker position had not been refreshed since the measurement setup had last changed.

Undefined header

Remote control error. The header is syntactically correct, but is undefined for this instrument.

Upper limit is less than lower limit for *<position>* in segment *<number>*

Within a limit specification, a lower limit cannot be set higher than an upper limit.

Appendix C

FAULT LOCATION MEASUREMENT PRINCIPLES

The following simplified discussion is intended only to acquaint the user with the measurement concept employed, and therefore does not include a mathematical analysis.

A fault in a transmission line will result in a reflection of the signal at the fault location. Observation of the reflected signal at some accessible point (e.g. at either end of the line) allows the determination of the fault location relative to the access point.

To make the above measurement the scalar frequency response of the line is measured, and the time domain response is subsequently computed from the measurements using Fourier Transform techniques.

To generate the frequency response the hardware configuration shown in Fig. C-1 can be used. A swept frequency signal is applied to the line via a symmetrical power divider. The input signal power is split into two paths: one is used as a reference, the other is the signal input to the line under test. The signal reflected from the discontinuity in the line is added vectorially at the divider to the reference signal. A scalar analyzer (e.g. 6800A) can be used to measure the amplitude of the vector addition of the two signals. An RF bridge can be used in place of the divider (as in the 6240 Series Fault Locator accessory), but the theory of operation remains the same.

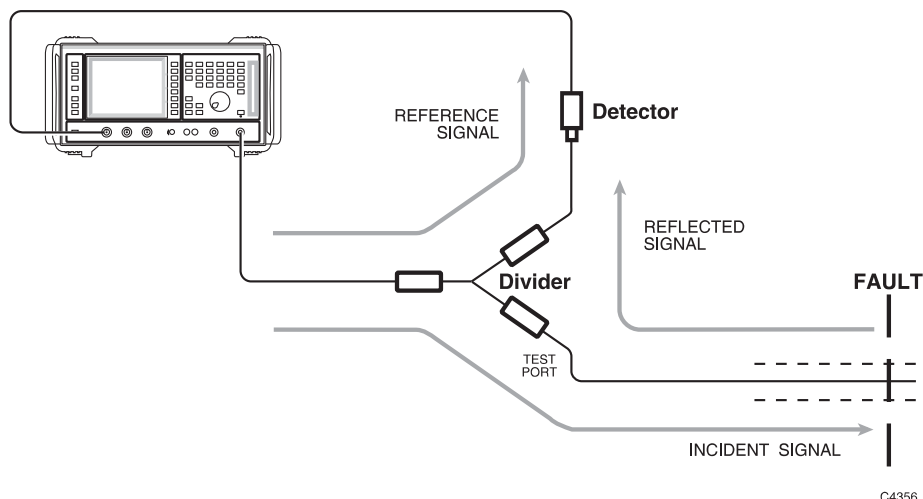

Fig. C-1 Fault Location Measurement System Configuration

To make a fault location measurement, a matched load is first connected to the test port and the scalar response of the power divider is measured. This constitutes calibration and in effect the response of the divider is obtained (i.e. the reference). When the line under test (assumed to have only one fault at the moment) is connected to the test port, its response adds vectorially to that of the divider. The vector addition depends on the phase angle between the two signals at the point of superposition, the centre of the divider. The phase angle in turn depends on the distance between the fault and the divider centre and the frequency.

As the frequency is swept linearly the phase angle changes in a similar fashion since the distance remains constant. Thus the magnitude of the vector sum, which is what the scalar analyzer measures, will vary periodically with frequency and is observed as a ripple (cosine) pattern. The period of the ripple is inversely proportional to the distance between the fault and the divider centre; the ripple amplitude is directly proportional to the reflection coefficient of the fault. Fault location could be extracted manually by measuring the ripple period, but the 6800A does this automatically by using Fourier Transform techniques.

When the Fourier Transform is applied to the cosine ripple pattern, an impulse function is obtained in the time domain. This impulse is displaced from the divider centre by an amount dependent on

the ripple period, and has an amplitude proportional to that of the ripple pattern. Knowing the velocity of propagation in the transmission line, the location of the fault can be located on a distance scale, which is what is displayed on the analyzer.

The above technique can also provide fault information for a transmission line with several faults. In this case the frequency domain response becomes a complicated ripple pattern which is the superposition of cosine waves having different amplitudes and periods. Visual interpretation would be impossible, but the Fourier Transform method results in the cosine waves transforming to impulse functions which are easily differentiated from each other.

Special features of the fault location measurements

Waveguide dispersion correction. In coaxial transmission lines signal velocity is constant at all frequencies. In waveguides signal velocity changes with frequency due to dispersion, i.e. wavelength is not inversely proportional to frequency. This means that as the frequency is swept the period of the observed ripples will change. The result is that the time domain impulses produced by the Fourier Transform are significantly spread, reducing resolution and making interpretation of the display difficult.

The 6800A uses a non-linear frequency sweep in order to re-establish the inverse relationship. The required frequencies are generated by the 6800A from a knowledge of the waveguide cut-off frequency, which determines the dispersion relationship. This parameter is entered by the operator when setting up a fault location measurement. Using this method, impulse spreading due to dispersion is eliminated at all points along the distance scale. Resolution is therefore maintained and interpretation of the display is easier. This method applies to any single conductor waveguide, such as rectangular, circular or elliptical.

Zoom mode. A sub-range of the measurement can be displayed, providing a zoom facility. This uses an enhanced accuracy mode which gives an optimally interpolated display trace resulting in improved distance and amplitude accuracy when displaying a sub-range.

Masking correction . A discontinuity or mismatch in a line can cause an error in the apparent magnitude of a fault beyond it, because the power reflected from the fault is attenuated by two passes through the preceding discontinuity. This leads to underestimates of the severity of distant faults.

The 6800A uses a special algorithm to compensate for the effects of reflections due to multiple faults. This is done by special processing of the time data. Each time a peak is identified, the magnitude of the peak is used to calculate the gain which should be applied to all subsequent peaks. As successive peaks are passed, the gain rises to account for the cumulative effect of masking.

Windowing . Because the data is sampled at discrete frequencies and is only available within the system bandwidth, sidelobes are introduced on the fault location display. The sidelobes result in the amplitude of the main peak being reduced, and also provide spurious peaks which can hide smaller reflections, hence limiting the dynamic range.

However, the frequency data can be processed by a method called windowing, so that the severity of sidelobes and amplitude errors is reduced. This can only be done at some cost to resolution, which results in some smearing of the peaks. The 6800A allows the user to select one of three windowing levels, which provide different trade-offs between sidelobe height and distance resolution.

6240 Series Fault Locator . For ease of use and more reliable measurements, the microwave components necessary for making both return loss and fault location measurements are integrated into a rugged metal housing. The unit comprises an integrated broadband high directivity bridge and fault location circuit, both with built-in detectors. A single low VSWR test port is used for both return loss and fault location measurements.

INDEX

A

AC detection 3-55, 3-91
AC power switch 3-10
Active function 3-14
Active marker 3-20, 3-21
Applications 3-31
 auto-run 3-268
 installing 3-267
 removing 3-267
 running 3-242
Attenuation of transmission line 3-93
Attenuation, spectrum analyzer input 3-49
Auto tune 3-49, 3-120
Autoscaling
 fault location measurements 3-187
 scalar measurements 3-163
AUX connector 2-5, 3-11
Averaging 3-100
AZ indicator 3-24

B

BACK SPACE key 3-16
Bandwidth measurements 3-173
Battery replacement 2-7

C

CAL key
 fault location channel 3-183
 scalar channel 3-151
 spectrum analyzer channel 3-203
Calibration
 fault location measurements 3-48, 3-183
 group delay measurements 3-46, 3-153
 scalar measurements 3-46, 3-151
 spectrum analyzer measurements 3-50, 3-203
Calibration, instrument 3-261
Centre/span frequency sweep mode 3-134
Channel coupling 3-17
Channel mode keys 3-12
Channel number 3-19
Channels 3-18
Colour palette 3-253
Connectors, precautions 3-41
Conversion measurements 3-45, 3-58, 3-65
Count indicator 3-23
Counter facility 3-50, 3-212
Coupled parameters 3-49, 3-124
Cutoff frequency 3-93
CW mode 3-135

D

Date & time setting 3-254

DC detection 3-55, 3-91
Default settings 3-280, A-1
Delta marker 3-25
Demodulation 3-50, 3-123
Detection mode 3-54
Detector correction 3-81
Detector zeroing 3-152, 3-184
Detectors, precautions 3-42
Dialogue box 3-14, 3-15
Disconnecting device 2-2
Display
 setup 3-41, 3-253
 test 3-262
DISPLAY key 3-51
Display keys 3-12
Dual channel display 3-18

E

EEPROM detectors 3-79
Electrical hazards v
Electrical Hazards v
ENTER/=MKR key 3-16
ENTRY OFF key 3-16
Error messages 3-24, B-1
EXT LEVEL INPUT connector 3-10
EXT MIXER connector 3-8
External frequency standard 3-44, 3-141
External keyboard 3-30
External mixer 3-128

F

FAULT LOCATION key 3-89
Fault location measurements 3-47
Fault location, measurement principles C-1
Fault Locator 3-47, C-2
File name entry 3-16
Flags, trace information 3-20, 3-21
Flatness correction 3-79, 3-81
Format, response values 3-20, 3-21
FREQ STANDARD connector 3-10
Frequency annotation, removing 3-246
Frequency counter, spectrum analyzer 3-50, 3-212
Frequency entry mode 3-93
Frequency modulation 3-44, 3-131, 3-136
Frequency standard, selecting 3-44, 3-141
Front panel features 3-7
Front panel keys 3-11
Fuses 2-4, 3-10

G

General information area 3-24
Goods-in checks 2-4

GPIB

- connector 2-5
- operation 3-244
- setting address 3-244

GPIB connector 3-11

Group delay measurements 3-45, 3-66

H

Hard copy output 3-27, 3-215

Hold measurement 3-52

I

Input attenuation 3-49, 3-124

Input connectors 3-8

Input offsets 3-80

Input selection, scalar 3-56

Input setup, scalar & fault location 3-79

International settings 3-30, 3-264

K

KEYBOARD connector 3-11

Keyboard layout, specifying 3-264

Keyboard test 3-262

Keyboard, external 3-30

L

Language, specifying 3-264

Large readout, active marker 3-166, 3-190, 3-210

Levelling 3-43, 3-140

Limit checking 3-26, 3-70

- editing specifications 3-72

Linearity correction 3-79, 3-81

Lithium batteries vi

LOCAL key 3-279

Lock instrument 3-246

Loop bandwidth, source 3-143

M

Marker coupling 3-25

Marker functions 3-25

Marker table 3-19

Markers 3-19, 3-24

MARKERS key

- fault location channel 3-188
- scalar channel 3-164
- spectrum analyzer channel 3-208

Masking correction 3-48, 3-90, C-2

Max/min function, scalar 3-165

Max/min tracking, scalar 3-167

Maximum function, fault location 3-189

Measurement definition 3-20, 3-21, 3-44

Measurement title 3-18

- creating 3-245

Measurement traces

- copying 3-28, 3-29
- creating hard copy 3-27
- saving to removable storage 3-28

Measurements

- conversion devices 3-45, 3-58, 3-65
- fault location 3-47
- general procedure 3-50
- group delay 3-45, 3-66
- precautions 3-41
- scalar 3-42
- spectrum analyzer 3-48
- tuned input 3-45, 3-57

Menu title 3-19

MIPlot application 3-27

Mixer measurements 3-59, 3-62, 3-63

MOD IN/OUT connector 3-10

MONITOR connector 2-6

N

Noise measurement, spectrum analyzer 3-212

Normalising 3-50, 3-204

Nrm indicator 3-21

Numeric entry 3-15

Numeric keypad 3-15

O

Operating precautions 3-41

P

PARALLEL PORT connector 2-6, 3-11

Parameter entry 3-15

Pass/fail indication 3-19

Password protection 3-31

Passwords, setting 3-32, 3-246

Path calibration

- fault location channel 3-185
- scalar channel 3-152

PC indicator 3-20

Peak hold 3-123

Peak search

- fault location channel 3-189
- spectrum analyzer channel 3-209, 3-211

Peak-to-peak measurements, group delay 3-168

Pk-pk measurements, group delay 3-169

Power requirements 2-4

Power sweep 3-137

PRESET key 3-280

Primary password 3-31

PRINT key 3-215

Print options 3-217

Printer drivers, selecting and installing 3-222

Printers, installing 3-33

Printing 3-27, 3-215

Pulse modulation 3-44

- edit pattern 3-147

set pattern 3-146
 single pulse 3-145
 source 3-144
 trigger 3-148
 Pulse modulator 4-4

R

Rack mounting 2-6
 Range entry mode 3-93
 Real time clock 3-41
 Rear panel features 3-10
 Reference level 3-20, 3-21, 3-162, 3-187, 3-206
 Reference position 3-19, 3-162, 3-187, 3-206
 Reference position indicator 3-19, 3-20, 3-21
 Relative to carrier measurement 3-212
 Relative to memory operations 3-232
 Relative velocity 3-93
 REMLOC indicator 3-24
 REMOTE indicator 3-24
 Remote operation 3-41, 3-244
 Removable storage 3-28
 Resolution bandwidth 3-49, 3-122
 Resolution, frequency counter 3-212
 Response 3-20, 3-21
 Rotary control 3-16
 RS-232
 connector 2-4, 3-11
 operation 3-244
 RUN APPS key 3-241

S

Safety testing (routine) 2-8
 SAVE/RECALL key 3-227
 Saving instrument settings 3-233
 Saving measurement traces 3-28, 3-229
 Scalar inputs 3-44
 SCALAR key 3-53
 Scalar measurements 3-42
 SCALE/FORMAT key
 fault location channel 3-186
 scalar channel 3-161
 spectrum analyzer channel 3-205
 Scaling, response values 3-20, 3-21
 Screen dump 3-28, 3-216
 Screen title 3-24
 creating 3-245
 Search function
 scalar channel 3-172
 spectrum analyzer channel 3-212
 Security functions 3-246
 SELECT MEAS key 3-51
 Self tests 3-42
 Setup & analysis keys 3-13
 SIGNAL SOURCE OUTPUT connector 3-8
 Signal tracking, spectrum analyzer 3-49, 3-121
 Single-ended insertion loss measurement 3-156
 Slope of trace, scalar 3-171

Smoothing 3-68, 3-69
 Soft key labels 3-19
 Soft key menus 3-11
 Soft keys 3-14
 Source control
 frequency modulation 3-44, 3-131, 3-136
 pulse modulation 3-44
 scalar measurements 3-43
 spectrum analyzer measurements 3-49
 SOURCE key
 fault location channel 3-179
 scalar channel 3-131
 spectrum analyzer channel 3-195
 Source mode
 scalar channel 3-131, 3-139
 spectrum analyzer channel 3-23, 3-195
 SOURCE ON/OFF key 3-281
 Source only mode 3-29, 3-131, 3-179, 3-195
 SPECTRUM ANALYZER INPUT connector 3-8
 Spectrum analyzer measurements 3-48
 Spectrum analyzer receiver parameters 3-23
 SPECTRUM key 3-119
 Spreadsheet format 3-229
 Start/stop frequency sweep mode 3-132
 Step keys 3-16
 defining step size 3-247
 Step size, defining 3-247
 Storage of instrument 2-9
 Store management 3-248
 SUPPLY switch 3-7
 Sweep time 3-125, 3-138
 SWITCH CHANNEL key 3-51
 Switching on 3-42
 System keys 3-14

T

Terminator keys 3-15
 Text entry 3-16
 Tilt warning vi
 Titles, creating 3-245
 Trace information area 3-19
 Trace number 3-19, 3-21
 Tracking generator 3-49, 3-199
 Transmission line database 3-47, 3-92, 3-95
 functions 3-103
 Transmission line store 3-99
 Tuned input scalar measurements 3-45, 3-57

U

UNLEV indicator 3-24
 UNLOC indicator 3-24
 User-defined passwords 3-32

INDEX

V

Video bandwidth 3-49, 3-124
Voltage output 3-44, 3-142
VOLUME control 3-8

W

Windowing 3-48, 3-101, C-2

X

X-axis annotation

scalar channel 3-22, 3-58, 3-65, 3-78

spectrum analyzer channel 3-23, 3-126, 3-127

X-domain information 3-22

XMV indicator 3-24

XSTD? indicator 3-24

Z

Zeroing, detectors 3-152, 3-184

Zeroing, group delay 3-67

Zoom indicator 3-22

Zoom mode 3-48, 3-102

AEROFLEX INTERNATIONAL LIMITED SOFTWARE LICENSE AND WARRANTY

This document is an Agreement between the user of this Licensed Software, the Licensee, and Aeroflex International Limited ('Aeroflex'), the Licensor. By installing or commencing to use the Licensed Software you accept the terms of this Agreement. If you do not agree to the terms of this Agreement do not use the Licensed Software.

1. DEFINITIONS

The following expressions will have the meanings set out below for the purposes of this Agreement:

Add-In Application Software	Licensed Software that may be loaded separately from time to time into the Designated Equipment to improve or modify its functionality
Computer Application Software	Licensed Software supplied to run on a standard PC or workstation
Designated Equipment	means either: the single piece of equipment or system supplied by Aeroflex upon which the Licensed Software is installed; or a computer that is connected to a single piece of equipment or system supplied by Aeroflex upon which computer the Licensed Software is installed
Downloaded Software	any software downloaded from an Aeroflex web site
Embedded Software	Licensed Software that forms part of the Designated Equipment supplied by Aeroflex and without which the Equipment cannot function
License Fee	means either the fee paid or other consideration given to Aeroflex for the use of the Licensed Software on the Designated Equipment
Licensed Software	all and any programs, listings, flow charts and instructions in whole or in part including Add-in, Computer Application, Downloaded and Embedded Software supplied to work with Designated Equipment
PXI Software	Licensed Software specific to Aeroflex's 3000 Series PXI product range

2. LICENSE FEE

The Licensee shall pay the License Fee to Aeroflex in accordance with the terms of the contract between the Licensee and Aeroflex.

3. TERM

This Agreement shall be effective from the date of receipt or download (where applicable) of the Licensed Software by the Licensee and shall continue in force until terminated under the provisions of Clause 8.

4. LICENCE

- 4.1 The following rights and restrictions in this Article 4 apply to all Licensed Software unless otherwise expressly stated in other Articles of this Agreement.
- 4.2 Unless and until terminated, this License confers upon the Licensee the non-transferable and non-exclusive right to use the Licensed Software on the Designated Equipment.
- 4.3 The Licensee may not use the Licensed Software on other than the Designated Equipment, unless written permission is first obtained from Aeroflex and until the appropriate additional License Fee has been paid to Aeroflex.
- 4.4 The Licensee may not amend or alter the Licensed Software and shall have no right or license other than that stipulated herein.
- 4.5 Except as specifically permitted elsewhere in this Agreement the Licensee may make not more than two copies of the Licensed Software (but not the Authoring and Language Manuals) in machine-readable form for operational security and shall ensure that all such copies include Aeroflex's copyright notice, together with any features which disclose the name of the Licensed Software and the Licensee. Furthermore, the Licensee shall not permit the Licensed Software or any part to be disclosed in any form to any third party and shall maintain the Licensed Software in secure premises to prevent any unauthorized disclosure. The Licensee shall notify Aeroflex immediately if the Licensee has knowledge that any unlicensed party possesses the Licensed Software. The Licensee's obligation to maintain confidentiality shall cease when the Licensed Software and all copies have been destroyed or returned. The copyright in the Licensed Software shall remain with Aeroflex. The Licensee will permit Aeroflex at all reasonable times to audit the use of the Licensed Software.
- 4.6 The Licensee will not disassemble or reverse engineer the Licensed Software, nor sub-license, lease, rent or part with possession or otherwise transfer the whole or any part of the Licensed Software.

5 ADDITIONAL LICENSE RIGHTS SPECIFIC TO PXI SOFTWARE

5.1 Definitions for PXI Software

The following expressions will have the meanings set out below for the purposes of the supplementary rights granted in this Article.

PXI Drivers	All 3000 Series PXI module device drivers including embedded firmware that are installed at runtime
PXI Executable Applications	All executable applications supplied with each 3000 Series PXI module including:- PXI Studio Soft Front Panels (manual operation graphical user interfaces) Utilities including: RF Investigator, PXI Version Information and Self Test
PXI Spectrum Analysis Library	The spectrum analysis measurement suite library .dll software supplied with each 3000 Series PXI module
PXI Optional Application Library	Individual measurement suite available from a range of optional .dll application libraries

5.2 PXI Drivers, PXI Executable Applications and PXI Spectrum Analysis Library License Rights

Subject to the License granted in Article 4 hereof notwithstanding the limitations on number of copies in Clause 4.5 hereof, the Licensee is entitled to make and distribute as many copies of the PXI Drivers and PXI Executable Applications as necessary for use with 3000 Series PXI modules acquired by the Licensee from Aeroflex or its authorized distributor or reseller provided that the Licensee may not sell or charge a fee for the PXI Drivers and PXI Executable Applications.

5.3 PXI Optional Application Library License Rights

Subject to the License granted in Article 4 hereof notwithstanding the limitations on number of copies in Clause 4.5 hereof, the Licensee is entitled to distribute as many copies of any PXI Optional Application Library as necessary for use with 3000 Series PXI modules acquired by the Licensee from Aeroflex or its authorized distributor or reseller provided that:

5.3.1 copies of the applicable PXI Optional Application Library are used solely with 3000 Series PXI modules which the customer has purchased with the corresponding option or part number for the applicable PXI Optional Application Library; and

5.3.2 the Licensee may not sell or charge a fee for the PXI Optional Application Library.

6 WARRANTY

6.1 Aeroflex certifies that the Licensed Software supplied by Aeroflex will at the time of delivery function substantially in accordance with the applicable Software Product Descriptions, Data Sheets or Product Specifications published by Aeroflex.

6.2 The warranty period (unless an extended warranty for Embedded Software has been purchased) from date of delivery in respect of each type of Licensed Software is:

PXI Drivers	24 months
Embedded Software	12 months
Add-In Application Software	90 days
Computer Application Software	90 days
Downloaded Software	No warranty

6.3 If during the appropriate Warranty Period the Licensed Software does not conform substantially to the Software Product Descriptions, Data Sheets or Product Specifications Aeroflex will provide:

6.3.1 In the case of Embedded Software and at Aeroflex's discretion either a fix for the problem or an effective and efficient work-around.

6.3.2 In the case of Add-In Application Software and Computer Application Software and at Aeroflex's discretion replacement of the software or a fix for the problem or an effective and efficient work-around.

6.4 Aeroflex does not warrant that the operation of any Licensed Software will be uninterrupted or error free.

6.5 The above Warranty does not apply to:

6.5.1 Defects resulting from software not supplied by Aeroflex, from unauthorized modification or misuse or from operation outside of the specification.

6.5.2 Third party produced proprietary software which Aeroflex may deliver with its products, in such case the third party software license agreement including its warranty terms shall apply.

6.6 The remedies offered above are sole and exclusive remedies and to the extent permitted by applicable law are in lieu of any implied conditions, guarantees or warranties whatsoever and whether statutory or otherwise as to the Licensed Software all of which are hereby expressly excluded.

7. INDEMNITY

7.1 Aeroflex shall defend, at its expense, any action brought against the Licensee alleging that the Licensed Software infringes any patent, registered design, trademark or copyright, and shall pay all Licensor's costs and damages finally awarded up to an aggregate equivalent to the License Fee provided the Licensee shall not have done or permitted to be done anything which may have been or become any such infringement and shall have exercised reasonable care in protecting the same failing which the Licensee shall indemnify Aeroflex against all claims costs and damages incurred and that Aeroflex is given prompt written notice of such claim and given information, reasonable assistance and sole authority to defend or settle such claim on behalf of the Licensee. In the defense or settlement of any such claim, Aeroflex may obtain for the Licensee the right to continue using the Licensed Software or replace it or modify it so that it becomes non-infringing.

7.2 Aeroflex shall not be liable if the alleged infringement:

- 7.2.1 is based upon the use of the Licensed Software in combination with other software not furnished by Aeroflex, or
 - 7.2.2 is based upon the use of the Licensed Software alone or in combination with other software in equipment not functionally identical to the Designated Equipment, or
 - 7.2.3 arises as a result of Aeroflex having followed a properly authorized design or instruction of the Licensee, or
 - 7.2.4 arises out of the use of the Licensed Software in a country other than the one disclosed to Aeroflex as the intended country of use of the Licensed Software at the commencement of this Agreement.
- 7.3 Aeroflex shall not be liable to the Licensee for any loss of use or for loss of profits or of contracts arising directly or indirectly out of any such infringement of patent, registered design, trademark or copyright. Notwithstanding anything in this Agreement to the contrary, the total liability of Aeroflex and its employees, in contract, tort, or otherwise (including negligence, warranty, indemnity, and strict liability) howsoever arising out of this License shall be limited to the total amount of the License Fee and total support fees actually paid to Aeroflex by the Licensee.

8. TERMINATION

- 8.1 Notwithstanding anything herein to the contrary, this License shall forthwith determine if the Licensee:
- 8.1.1 As an individual has a Receiving Order made against him or is adjudicated bankrupt or compounds with creditors or as a corporate body, compounds with creditors or has a winding-up order made against it or
 - 8.1.2 Parts with possession of the Designated Equipment.
- 8.2 This License may be terminated by notice in writing to the Licensee if the Licensee shall be in breach of any of its obligations hereunder and continue in such breach for a period of 21 days after notice thereof has been served on the Licensee.
- 8.3 On termination of this Agreement for any reason, Aeroflex may require the Licensee to return to Aeroflex all copies of the Licensed Software in the custody of the Licensee and the Licensee shall, at its own cost and expense, comply with such requirement within 14 days and shall, at the same time, certify to Aeroflex in writing that all copies of the Licensed Software in whatever form have been obliterated from the Designated Equipment.

9. THIRD PARTY LICENCES

- 9.1 The Licensed Software or part thereof may be the proprietary property of third party licensors. In such an event such third party licensors (as may be referenced on the software media, or any on screen message on start up of the software or on the order acknowledgement) and/or Aeroflex may directly enforce the terms of this Agreement and may terminate the Agreement if the Licensee is in breach of the conditions contained herein.
- 9.2 If any third party software supplied with the Licensed Software is supplied with, or contains or displays the third party's own license terms then the Licensee shall abide by such third party license terms (for the purpose of this Article the term "third party" shall include other companies within the Aeroflex group of companies).

10. EXPORT REGULATIONS

The Licensee undertakes that where necessary the Licensee will conform with all relevant export regulations imposed by the Governments of the United Kingdom and/or the United State of America.

11. U.S. GOVERNMENT RESTRICTED RIGHTS

The Licensed Software and documentation are provided with RESTRICTED RIGHTS. Use, duplication, or disclosure by the Government is subject to restrictions as set forth in subparagraph (c)(1)(ii) of the Rights in Technical Data and Computer Software clause at DFARS 252.227-7013 or subparagraphs (c)(1) and (2) of the Commercial Computer Software-Restricted Rights at 48 CFR 52.227-19, as applicable.

12. NOTICES

Any notice to be given by the Licensee to Aeroflex shall be addressed to:

Aeroflex International Limited, Longacres House, Six Hills Way, Stevenage, SG1 2AN, UK.

13. LAW AND JURISDICTION

This Agreement shall be governed by the laws of England and shall be subject to the exclusive jurisdiction of the English courts. This agreement constitutes the whole agreement between the parties and may be changed only by a written agreement signed by both parties.

**CHINA Beijing**

Tel: [+86] (10) 6539 1166
Fax: [+86] (10) 6539 1778

CHINA Shanghai

Tel: [+86] (21) 5109 5128
Fax: [+86] (21) 5150 6112

FINLAND

Tel: [+358] (9) 2709 5541
Fax: [+358] (9) 804 2441

FRANCE

Tel: [+33] 1 60 79 96 00
Fax: [+33] 1 60 77 69 22

GERMANY

Tel: [+49] 8131 2926-0
Fax: [+49] 8131 2926-130

HONG KONG

Tel: [+852] 2832 7988
Fax: [+852] 2834 5364

INDIA

Tel: [+91] 80 5115 4501
Fax: [+91] 80 5115 4502

KOREA

Tel: [+82] (2) 3424 2719
Fax: [+82] (2) 3424 8620

SCANDINAVIA

Tel: [+45] 9614 0045
Fax: [+45] 9614 0047

SPAIN

Tel: [+34] (91) 640 11 34
Fax: [+34] (91) 640 06 40

UK Burnham

Tel: [+44] (0) 1628 604455
Fax: [+44] (0) 1628 662017

UK Stevenage

Tel: [+44] (0) 1438 742200
Fax: [+44] (0) 1438 727601
Freephone: 0800 282388

USA

Tel: [+1] (316) 522 4981
Fax: [+1] (316) 522 1360
Toll Free: (800) 835 2352

As we are always seeking to improve our products, the information in this document gives only a general indication of the product capacity, performance and suitability, none of which shall form part of any contract. We reserve the right to make design changes without notice.

web www.aeroflex.com

Email info-test@aeroflex.com

November 2005