

Provided by:

Quality is more than a word

**ESPEC**

# Highly Accelerated Stress Test System (HAST Chamber)



# Creates temperature, humidity and pressure environments to IEC60068-2-66 standard.

Humidity resistance evaluation tests for electronic components

Customers require test results that correlate accurately to those from the field in a minimal amount of time.

ESPEC HAST EHS series provide high usability and a variety of performance capabilities to meet IEC60068-2-66 standard and other international standards with convenient functions and safety features for bias testing.





EHS-412M



EHS-222MD



\* Product image with options (Emergency stop switch, additional specimen signal terminals and cover). (Cover page, P.2 and P.10)

# Features

## Designed for humidity resistance testing, life testing and accelerated testing



Chamber interior

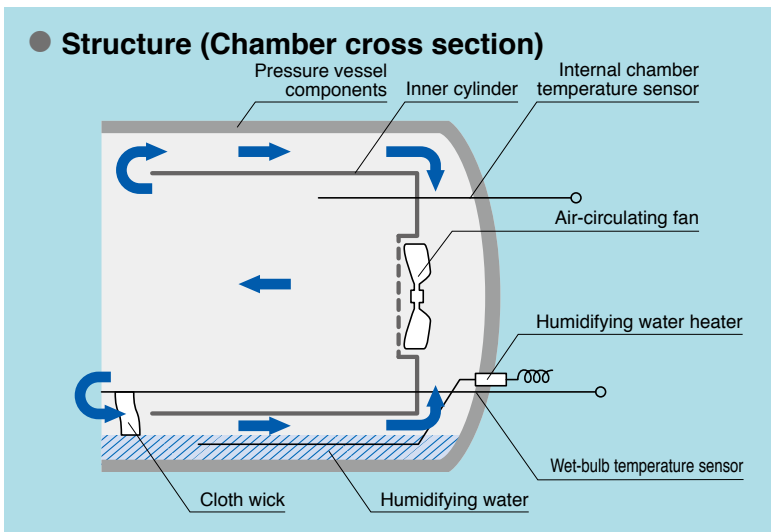

Specimen signal terminals (internal)



Specimen signal terminals (external)

- **Air-circulating fan for high-accuracy testing**

The air-circulating fan minimizes variations in temperature and humidity in the test area for greater accuracy during testing. The fan enables uniform stress to be applied to a specimen.

- **Maximized workspace**

The cylindrical pressure vessel distributes pressure evenly and offers superior strength. Interior is expanded for easier loading of a large specimen such as printed circuit board.

- **Prevention of dew condensation and wetting of specimens**

Compared with natural convection test systems, the double cylindrical structure and proprietary air-conditioning system prevents dew condensation and water droplets falling on the specimen. Temperature control and operation of the test area fan before and after testing also prevents dew condensation and droplets from forming on samples, ensuring highly readable testing results. (Featuring dry and wet-bulb temperature control and unsaturated control)

- **Color coding for easy connection**

Specimen signal terminals with 12 power-pins per unit is equipped as standard. Additional 12 pins per set are available as optional and can be expanded up to total 72 pins. Complicated connection work is also made easier thanks to color-coded terminal (black = negative, red = positive).

- **Specimen protection from risk of damage**

A specimen power supply control terminal is equipped as one of safety features, which output contact signals to allow voltage and signals to be applied to the specimen during testing. In the case of activation of safety devices such as overheat protection and boil-dry protection, any externally-powered devices can be also turned off with this terminal to avoid the risk of damage to the specimen or the chamber.

# Features

## 5.7-inch color LCD touch panel

### Color LCD touch panel

The Resistive Touch Panel provides versatility by allowing users to use gloves, wet hands, nails and stylus to interact with the panel.

### Multilingual support \NEW/

You can select the display language from Japanese/English/Chinese(Simplified/Traditional)/Korean and the changes take effect immediately without a system reboot.

### Temperature, humidity and pressure graph display function

The Trend-Graph Display Function allows users to monitor the temperature, humidity, and pressure\* conditions in the test area, in a graph.

\* Pressure monitoring function or recorder option is required.

### Pressure monitoring function (option)

The pressure can be displayed on the screen or can be read via the Ethernet, RS-485 (option) or RS-232C (option). Monitored value on the screen can be switched between humidity and pressure.

### Auto-locking mechanism

Door lock safety mechanism to prevent opening of the door while the chamber is pressurized.

### Automatic humidity filling

The humidifying water is filled from the built-in water supply tank at the start of a test automatically.

The water level in a tank can be checked from outside through the slits on the front cover.

Bottom of the unit allows storage space for power supply unit and peripheral equipment.

### No pressure or temperature shock after testing prevents specimens from drying out

Gradual depressurization and air/water drainage mechanisms eliminate sudden changes in pressure and temperature after testing is completed, thus ensuring moisture contained in the specimen does not evaporate. This provides more accurate test results in correlation to the field.

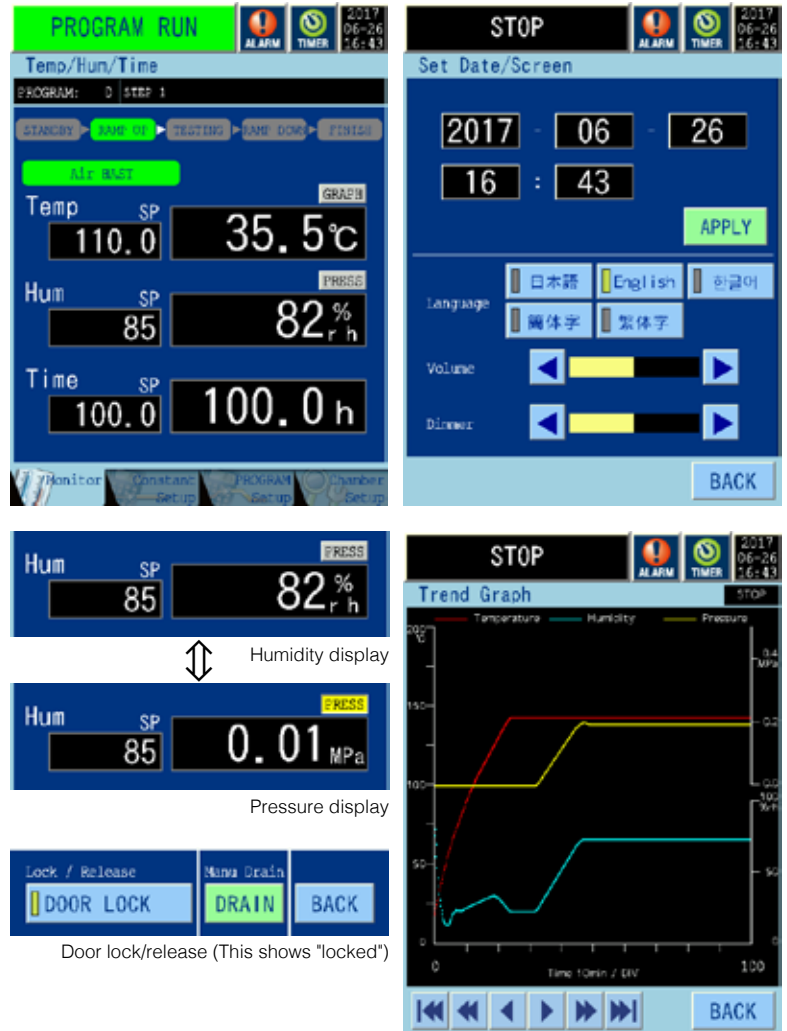

Trend Graph



Water tank and storage space at the bottom of the chamber



# Features

## ● Control functions that make use of conventional test data

The control functions can be selected from dry & wet-bulb temperature control (M/MD type), unsaturated control, and wet-saturated control according to the conventional test data.

With the addition of Air-HAST mode (for M/MD type only), four different types of testing can be performed on one chamber.

## ● Three modes of operation control

Wet and dry bulb temperature control (M/MD type)

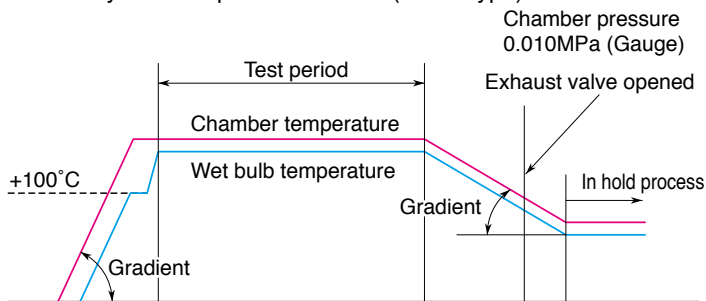

- The temperature and humidity gradient before and after testing can be controlled.
- After testing is complete and chamber pressure reaches 0.010MPa (Gauge), only air is discharged; humidifying water is retained.
- In the hold process, temperature and humidity inside the chamber are maintained at the specified level. (+50 to +95°C/75 to 95%rh)

Unsaturated control (humidifying water temperature control)

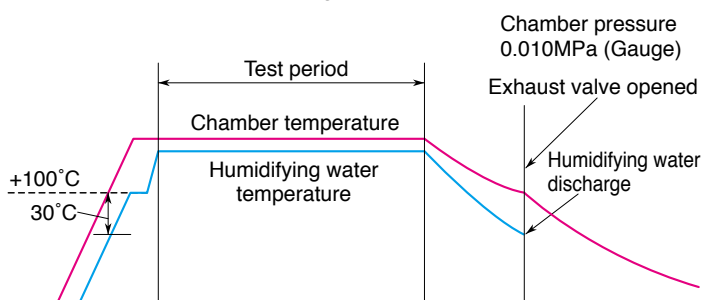

- During temperature heat-up when condensation can easily occur on the specimen, the temperature of the humidifying water automatically increases while keeping it 30°C lower than the chamber temperature.
- After testing is complete, the chamber is left to cool and depressurize naturally until chamber pressure reaches 0.010MPa (Gauge). Then both air and water are discharged.

Wet saturated control

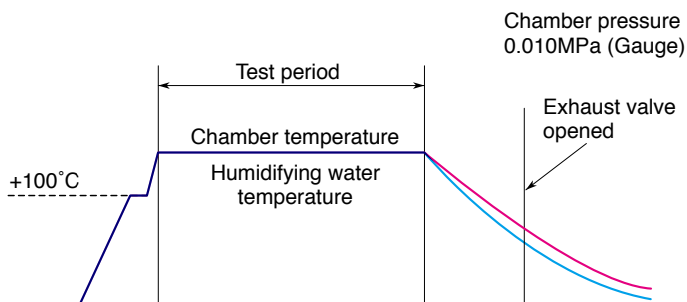

- Chamber temperature is controlled through a humidifying heater. (chamber temperature = humidifying water temperature)
- After testing is complete, the chamber is left to cool and depressurize naturally until chamber pressure reaches 0.010MPa (Gauge). Then only air is discharged; humidifying water is retained.

# Features

## Reproduction of near-constant temperature and humidity testing environment with Air-HAST (option)

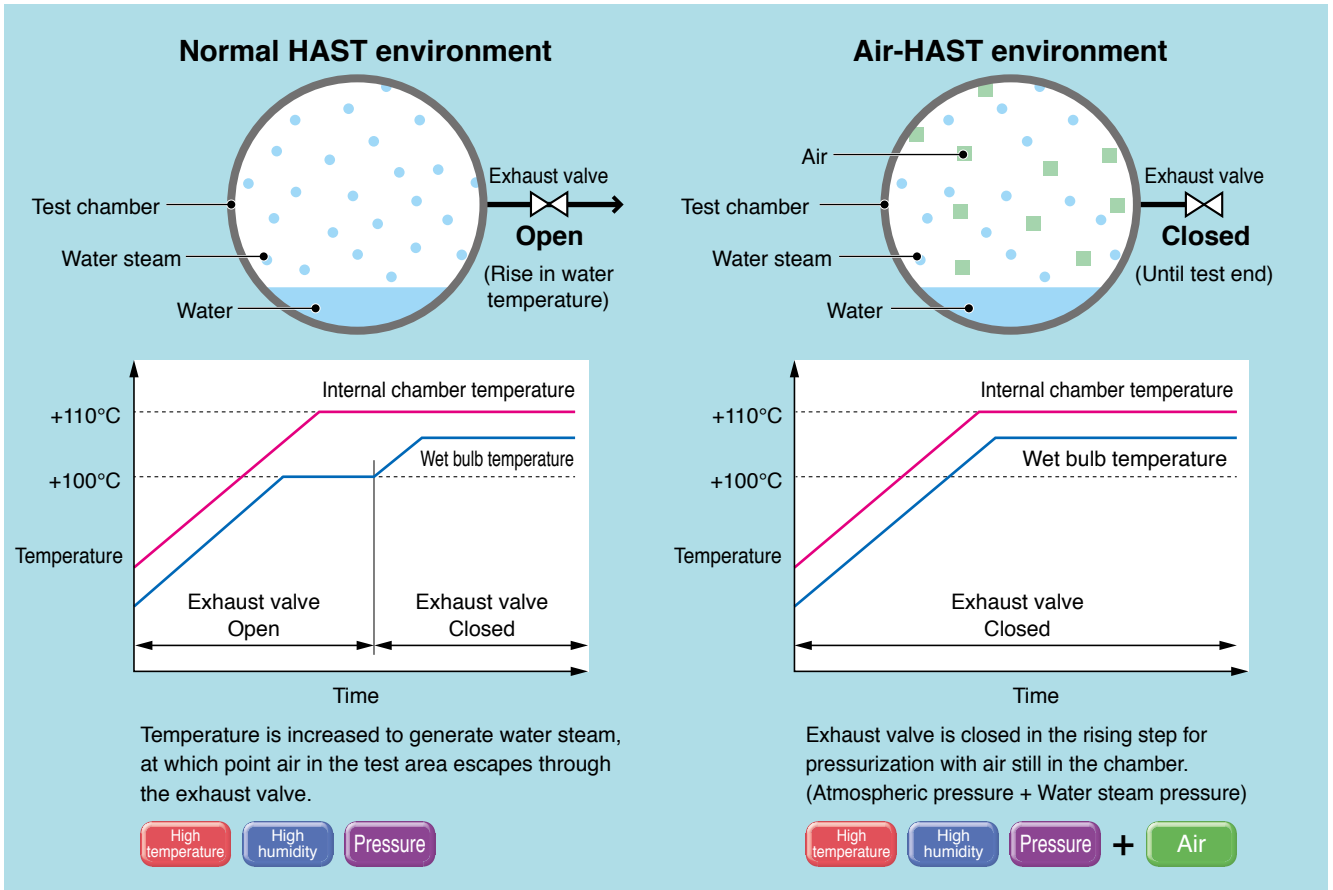

### ● Air-HAST function (option for M/MD type)

Depending on the specimen, not only water steam but also oxidation and other specimen surface conditions can cause failure. By leaving air in the test area, the Air-HAST function adds air to the high-temp, high-humidity, and pressurized environment for effective accelerated testing of specimens for which the oxygen in air affects degradation, such as with surface oxidation. (Acceleration may not be seen for some specimen.)

### ● Whisker humidity-resistance evaluation testing (Japanese patent No. 5066143)

Evaluation examples for whisker evaluations of mounting boards are limited. One of the main reasons for this is because the testing time can be as long as 1000 or 3000 hours. To shorten these testing times, ESPEC conducts lead-free solder whisker evaluation of mounting boards using Air-HAST. The results confirmed accelerated effects with testing at 85°C and 85%rh humidity.

### ● Air-HAST temperature and humidity control range

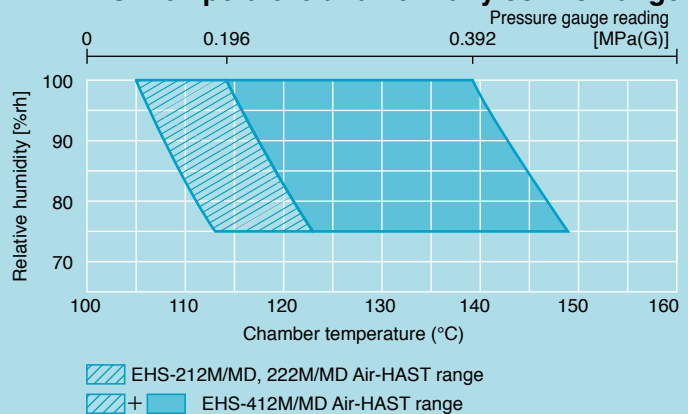

### Accelerated testing examples for whisker evaluation

Temperature cycling test	-40 ↔ +85°C	3000 cycles
High temperature and high humidity test	+55°C/85%rh	3000 hours
	+85°C/85%rh	1000 hours
Air-HAST	+110°C/85%rh (Air pressure 130kPa)	200 hours

# Features

## Easy customization with various options



Integration with Electro-chemical migration system (example)



Slide shelf terminal block (option)



Status indicator lights (option)

### ● Electro-chemical migration evaluation

Integration with an ESPEC Electro-chemical migration evaluation system (sold separately) enables more accurate measurements.

### ● High-voltage, high-current compatibility

To meet application purposes and goals, ESPEC offers optional high-voltage (1000V AC/DC, 1A) / high-current (125V AC/DC, 10A) specimen signal terminals in addition to the standard specifications (125V AC/DC, 1A).

### ● Terminal block to increase productivity

Using the slide shelf terminal block (option), the terminal block can be pulled forward from inside the test area to facilitate wiring work.

In addition, removable 12-channel terminal blocks (option) can be added inside the chamber. This reduces the time required for installation and wiring for greater work efficiency.

### ● Safety enhancement functions available

Optional emergency stop switches and status indicator lights are available.

### ● International standards

Complies with the following standards:  
ISO 12100 Safety of Machinery  
IEC 60204 Low Voltage  
IEC 61000-6-2 EMC  
IEC 61000-6-4 EMC  
RoHS Directive



# Features

## Conforms to international IEC 60068-2-66 standard

### ● Temperature and humidity control for support of various test standards

With ESPEC's unique wet and dry bulb temperature control on M/MD type chamber, temperature and humidity are measured directly using a wet and dry bulb temperature sensor. This ensures highly precise temperature and humidity control over the entire testing process, from before testing to the post-testing temperature decrease or hold process.

After testing is complete, the temperature and humidity are allowed to drop for a fixed period. In the hold process, the chamber is kept at a fixed environment until the door is opened and specimens are removed. This makes it possible to place a specimen in a constantly controlled temperature/humidity environment, and keep it from drying after returning to atmospheric pressure.

### ● IEC 60068-2-66, an environmental testing standard of the IEC (International Electrotechnical Commission)

The Highly Accelerated Stress Test System EHS Series uses ESPEC's unique dry and wet-bulb temperature control to satisfy the test system conditions and test operations specified in the IEC 60068-2-66 standard.

\* ESPEC was directly involved in drawing up the IEC60068-2-66 standard, and our technical concepts and measurement data were used in its development.

## APPLICABLE STANDARDS

Standard No. Standard Name Applications	Test conditions			
	Temperature (°C)	Humidity (%rh)	Biased	Time (h)
IEC 60068-2-66 (JIS C 60068-2-66) Damp heat, steady state (unsaturated pressurized vapour) Electrics/electronics	110±2	85±5	Optional	96,192,408 (0, +2)
	120±2	85±5		48,96,192 (0, +2)
	130±2	85±5		24,48,96 (0, +2)
IEC 60749-4 HAST Electrics/electronics; Semiconductors	110±2	85±5	Continuous/ intermittent	264 (0, +2)
	130±2	85±5		96 (0, +2)
JEITA (EIAJ) Semiconductor devices Unsaturated steam pressure testing ED-4701/100A, Method 103	110±2	85±5	Continuous	24 (0, +8)
	120±2	85±5		48 (0, +8)
	130±2	85±5		96 (0, +8) 168 (0, +8) 500 (0, +8)
JESD22-A118B Unbiased HAST Semiconductors	110±2	85±5	None	264 (0, +2)
	130±2	85±5		96 (0, +2)
JESD22-A110E HAST Semiconductors	110±2	85±5	Continuous/ intermittent	264 (0, +2)
	130±2	85±5		96 (0, +2)
JESD22-A102E Unbiased Autoclave Semiconductors	121±2	100±5	None	24 (0, +2)
				48 (0, +2)
				96 (0, +5)
				168 (0, +5)
				240 (0, +8) 336 (0, +8)
AEC-Q100-Rev-H Biased HAST/Unbiased HAST Automotive semiconductors	110±2	85±5	Continuous/none	264 (0, +2)
	130±2	85±5		96 (0, +2)
JPCA-ET08 Unsaturated pressurized vapour Printed circuit boards	110±2	85±5	Continuous	96,192,408 (0, +2)
	120±2	85±5		48,96,192 (0, +2)
	130±2	85±5		24,48,96 (0, +2)

## SPECIFICATIONS

Model	EHS-212 (M)	EHS-212MD	EHS-222 (M)	EHS-222MD	EHS-412 (M)	EHS-412MD			
System	Single vessel, unsaturated control, wet saturated control, dry and wet-bulb temperature control								
Pressure vessel type	Small pressure vessel as specified in the Enforcement Order of Industrial Safety and Health Law in Japan								
Performance*1	Unsaturated control	Temperature control range	+105.0 to +142.9°C			+105.0 to +162.2°C			
		Humidity control range	75 to 100%rh						
		Pressure range	0.020 to 0.196 MPa (Gauge)			0.020 to 0.392 MPa (Gauge)			
		Temp. & humidity fluctuation	±0.3°C / ±2.5%rh						
		Temperature variation in space	3.0°C						
		Heat up and pressurization time	0 → 0.196 MPa (Gauge) Approx. 30 min.		0 → 0.196 MPa (Gauge) Approx. 60 min.		0 → 0.392 MPa (Gauge) Approx. 45 min.		
	Wet-saturated control	Temperature control range	+105.0 to +132.9°C			+105.0 to +151.1°C			
		Pressure range	0.020 to 0.196 MPa (Gauge)			0.020 to 0.392 MPa (Gauge)			
		Temperature fluctuation	±0.3°C						
		Temperature variation in space	3.0°C						
		Heat up and pressurization time	0 → 0.196 MPa (Gauge) Approx. 45 min.		0 → 0.196 MPa (Gauge) Approx. 75 min.		0 → 0.392 MPa (Gauge) Approx. 60 min.		
	Dry & wet-bulb temperature control (M/MD type)	Temp. heat-up	Temperature control range	+105.6 to +142.9°C			+105.6 to +162.2°C		
			Humidity control range	75 to 95%rh					
			Heat up and pressurization time	0 → 0.196 MPa (Gauge) Approx. 60 min.		0 → 0.196 MPa (Gauge) Approx. 90 min.		0 → 0.392 MPa (Gauge) Approx. 75 min.	
		Test process	Temperature control range	+105.6 to +142.9°C			+105.6 to +162.2°C		
			Humidity control range	75 to 98%rh					
			Pressure range	0.020 to 0.196 MPa (Gauge)			0.020 to 0.392 MPa (Gauge)		
			Temp. & humidity fluctuation	±0.3°C / ±2.5%rh					
		Temp. pull-down	Temperature variation in space	3.0°C					
			Temperature control range	+50.0 to +95.0°C					
Temperature pull down time			+142.9°C / 75%rh to +85.0°C / 85%rh		Approx. 120 min.		+162.2°C / 75%rh to +85.0°C / 85%rh    Approx. 120 min.		
Temperature control range	+50.0 to +95.0°C								
Humidity control range	75 to 95%rh								
Hold process	Wet-bulb wick	Capable of Approx. 200 hours chamber running time (Figure given for +162.2°C / 75%rh and no specimens)							
Noise emission*2	below 46 dB	below 50 dB	below 46 dB	below 50 dB	below 46 dB	below 50 dB			
Construction	Pressure vessel/door construction	Cr-Ni-Mo stainless steel plate							
	Pressure vessel components	Temperature sensor (Thermocouple type T [Copper/ Copper-Nickel] for measuring chamber temperature, humidifying water temperature, wet-bulb temperature), heater, specimen signal terminals, air-circulating fan, fan motor, overheat protector, boil-dry protector							
	Door	Door handle, door lock: Auto-locking mechanism (bank vault), instrumentation, instrumentation power switch							
	Pressure gauge (Bourdon type)	Scale: -0.1 to 0.4 MPa (Gauge)			Scale: -0.1 to 1 MPa (Gauge)				
	Test area	Specimen shelves, shelf brackets for test area: each×2							
Water supply	Water supply system	Automatic water supply							
	Water supply amount (at start)	Approx. 1 L		Approx. 1.5 L		Approx. 1 L			
	Water tank	10 L	20 L	10 L	20 L	10 L	20 L		
Components	Specimen signal terminals (connector-type, 12-pin, 125 VAC/VDC, 1 A), specimen power control terminals, external alarm terminals, Ethernet port (LAN port), power cable								
Caster	4	—	4	—	4	—			
Dimensions	Interior volume	21 L	21 L × 2	51 L	51 L × 2	21 L	21 L × 2		
	Test area dimensions*3	ø294 x D318(296) mm		ø394 x D426(404) mm		ø294 x D318(296) mm			
	Chamber outer dimensions (W x H x D mm)*4	640 x 1483 x 850	760 x 1796 x 1000	740 x 1553 x 1000	860 x 1796 x 1000	640 x 1483 x 850	760 x 1796 x 1000		
	Weight	190 kg	350 kg	230 kg	390 kg	190 kg	350 kg		
Utility requirements	Allowable ambient conditions	+5 to +40°C (+41 to +104°F)							
	Power supply	200V AC 1ø 50/60Hz	12.5 A	25 A	14 A	28 A	12.5 A	25 A	
		220V AC 1ø 50/60Hz	11.4 A	22.8 A	12.7 A	25.4 A	11.4 A	22.8 A	
		230V AC 1ø 50Hz	10.9 A	21.8 A	12.2 A	24.4 A	10.9 A	21.8 A	

\*1 The performance values are based on IEC60068-3-5:2001 and IEC60068-3-6:2001; Performance figures are given for a +23°C, ambient temperature relative humidity of 65±20%rh, rated voltage, and no specimen inside the test area.

\*2 Point of measurement: 1.2 m off floor, 1 m in front of chamber (JIS Z8731)

\*3 ( ):dimensions excluding fan guard protrusion.

\*4 Excluding protruding parts (fittings/components on rear)

## MODEL

EHS-□□2□

- Blank: Standard type
- M: M type (Single stage) – Wet and dry bulb temperature control
- MD: MD type (Double stage) – Wet and dry bulb temperature control
- Chamber capacity 1 : 21 L  
2 : 51 L
- Pressure range 2 : 0.020 to 0.196MPa (Gauge)  
4 : 0.020 to 0.392MPa (Gauge)



EHS-212      EHS-212MD      EHS-222      EHS-222MD  
 EHS-212M      EHS-412MD      EHS-222M  
 EHS-412  
 EHS-412M

## FITTINGS LOCATION

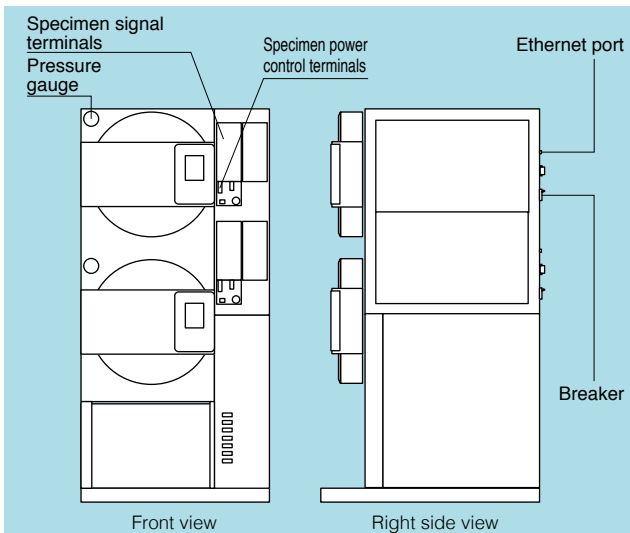

\* A main breaker and Ethernet port are equipped on the back of the chamber.

## TEMPERATURE AND HUMIDITY CONTROL RANGE

### ● TEST PROCESS

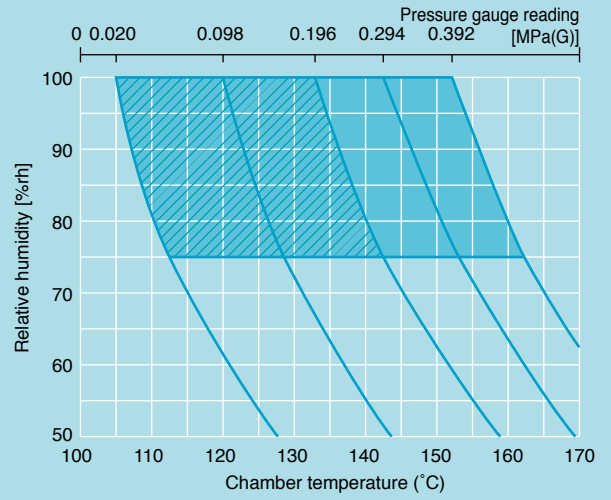

\* Humidity range is from 75% to 98% rh for wet and dry bulb control.

### ● HOLD PROCESS

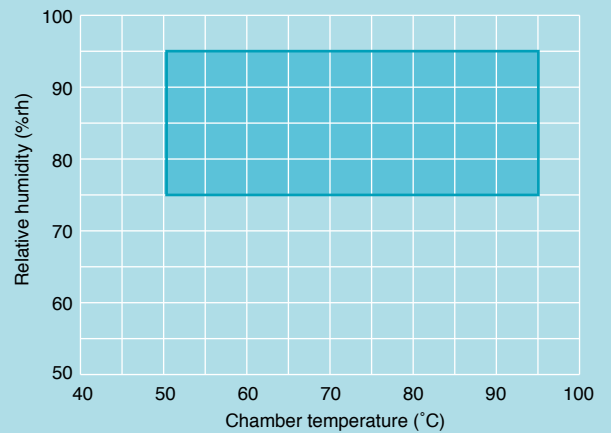

## SAFETY DEVICES

- Overcurrent protection (leakage breaker)
- Cartridge fuse for control circuit short-circuit protection
- Electrical compartment door switch
- System error (Error)
- Room temp. compensation burnout detection circuit
- Dry bulb temp. burnout detection circuit
- Humidifying water temp. burnout detection circuit
- Wet bulb temp. burnout detection circuit (for M/MD type only)
- Exhaust air temp. burnout detection circuit
- Absolute upper/lower temp. limit alarm (with built-in temp./humid. controller)
- Air circulating fan/motor rotation alarm
- Overheat protector (variable type)
- Overheat protector (fixed type)
- Heater overcurrent protection
- Humidifier overcurrent protection
- Humidifier dry heat protector
- Humidifier water level detection
- Dry wick detection (for M/MD type only)
- Water tank low-level switch
- Pressure alarm
- Door open alarm
- Door lock alarm
- Atmospheric pressure switch alarm
- Specimen power supply control terminal
- Safety valve

## ACCESSORIES

- Shelf ..... (large/small) 1 each
  - EHS-212(M)/412(M) Large: 286 (W) × 288 (D) mm  
Small: 234 (W) × 288 (D) mm
  - EHS-222(M) Large: 386 (W) × 396 (D) mm  
Small: 280 (W) × 416 (D) mm
- Shelf ..... (large/small) 2 each
  - EHS-212MD/412MD Large: 286 (W) × 288 (D) mm  
Small: 234 (W) × 288 (D) mm
  - EHS-222MD Large: 386 (W) × 396 (D) mm  
Small: 280 (W) × 416 (D) mm
- Specimen signal terminal Pin type, (125 VAC/VDC, 1 A) ..... 12 (MD type: 24)
- Breaker handle cover ..... 1 (MD type: 2)
- Wet bulb wick (for M/MD type only) ..... 50 (MD type: 100)
- Cartridge fuse 250 V ..... 7 (MD type: 14)
- Hose nipple ..... 1
- Eyebolt ..... 4 (for MD type only)
- Operation manual ..... 1

### Safety precautions

- Do not use specimens which are explosive or inflammable, or which contain such substances. To do so could be hazardous, as this may lead to fire or explosion.
- Do not place corrosive substances in the chamber. If corrosive substances are generated by the specimen, the life of the chamber may be significantly shortened specifically because of the corrosion of stainless steel and copper and because of the deterioration of resin and silicon.
- Do not place life forms or substances that exceed allowable heat generation.
- Be sure to read the operation manual before operation.

## OPTION

### Continuous water supply

This option is used to continuously supply pure water to the chamber.

A chamber dew tray (P.13) and other preventive measures (sold separately) are also available to protect floor from water damage.

### Water tank

For supplying water to the built-in water tank.

- 10 L × 3 with cart  
Tank with cock  
Capacity: 10 L × 3  
Cart size: W600 × H920 × D348
- 10 L × 1  
Tank with nozzle  
Capacity: 10 L



10 L × 3 with cart



10 L × 1

### Shelves and insulated shelves

Add standard shelves or change to insulated specifications (Teflon coating).



Standard shelves

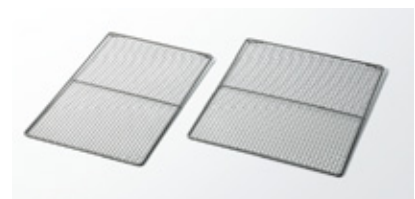

Insulated shelves

## OPTION

### Specimen basket

For small specimens that cannot be placed on the shelf.

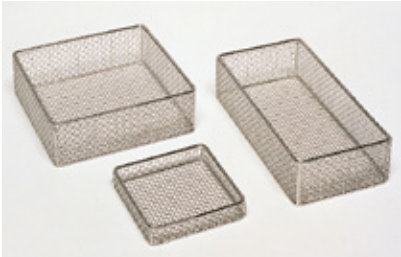

Type A: 150 (W) × 50 (H) × 150 (D) mm  
 Type B: 100 (W) × 50 (H) × 200 (D) mm  
 Type C: 95 (W) × 20 (H) × 95 (D) mm

### Removable terminal block

The terminal block allows terminals with 12 pins in the test area to be removed or attached all at once. This removable terminal block consists of a connector block (12-pin specimen signal terminal) and a chamber connector (with removal levers).  
 \* Cannot be attached if a slide shelf terminal block is being used.

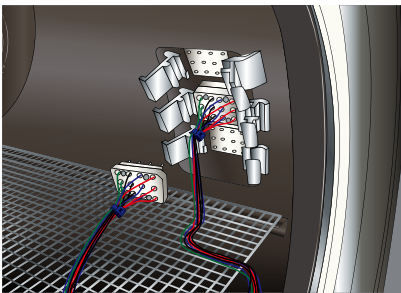

### Slide shelf terminal block

A slide shelf terminal block is equipped in the front of the test area. This terminal block allows wiring to be done outside the test area.  
 \* Cannot be attached if removable terminal blocks are being used.



### Air-HAST function (for M/MD type only)

This function pressurizes the test area with the air remaining.

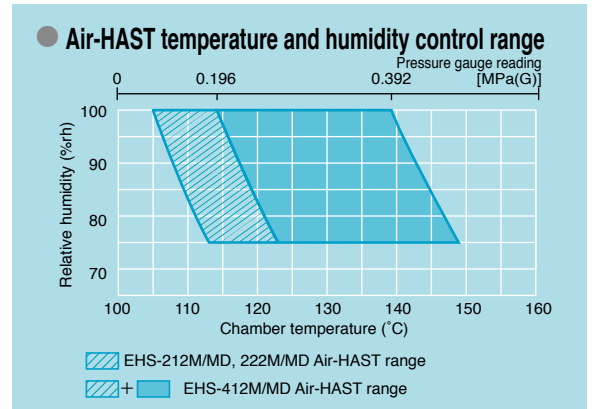

### Specimen signal terminals

Terminal rated capacity: AC/DC 125V 1A  
 EHS-212 (M)/412 (M)  
 12-pin (6-channel\*) × 4  
 EHS-212MD/412MD  
 12-pin (6-channel\*) × 4 × 2  
 EHS-222 (M)  
 12-pin (6-channel\*) × 5  
 EHS-222MD  
 12-pin (6-channel\*) × 5 × 2

\* The numbers of channels given are for configurations with two I/O systems.  
 \* To protect from electric shock and protect wiring, specimen signal terminal cover (option) is recommended.



EHS-222MD (Option 12-pin × 5)  
 (Standard 12-pin)

### Specimen signal terminal cover

The protective cover prevents direct contact with the specimen signal terminal block outside the test area.



### Interface

Communication ports to connect the chamber to a PC.

- RS-485
- RS-232C



## OPTION

### Specimen signal terminal for high current

This option changes the standard terminal (125V AC/DC, 1 A) to higher current specimen signal terminal (125V AC/DC, 10 A).

Type 1: 6-pin (3-channel)  
up to 5 sets

Type 2: 6-pin (3-channel)  
up to 6 sets

\* Cannot be attached if a specimen signal terminal block for high voltage is being used.



### Specimen signal terminal for high voltage

This option changes the standard terminal (125V AC/DC, 1 A) to higher voltage specimen signal terminal (1000V AC/DC, 1 A).

Type 1: 6-pin (3-channel)  
up to 5 sets

Type 2: 6-pin (3-channel)  
up to 6 sets

\* Cannot be attached if a specimen signal terminal block for high current is being used.



### Time signal output terminal

Contact output specifications

- Operation: on/ off at each step
- Number of channels: 2

### Paperless recorder-portable type

A temperature & humidity recorder that utilizes a liquid-crystal display fitted with a touch-panel. Records temperature, humidity and pressure inside the chamber.

Display: 5.7-inch TFT color LCD

Temperature range: 0 to +200°C

Humidity range: 0 to 100%rh

Pressure range: -0.1 to 0.5 MPa (Gauge)  
Number of inputs: 1 (3 more channels can be turned ON)

Data saving cycle: 5 sec

Internal recording media: Flash memory 8 MB

External recording media: CF memory card port

(Includes a 256 MB CF card)

USB memory port

### Temp. humid. pressure recorder-portable type

Temperature range: 0 to +200°C

Humidity range: 0 to 100%rh

Pressure range: -0.1 to 0.5 MPa (Gauge)

### Pressure monitoring function

The monitored pressure can be shown on the monitor screen and trend graph screen of instrumentation panel.



### Wet-bulb wick

Same as the standard accessory.

1 set (50 pieces)

### Status indicator light

This option is used for remotely checking the status of the chamber. Please select lighted or blinking, and requirement of buzzer sound.



Location:

Single stage type: Chamber top

Double stage type(MD type): Chamber top left side for the upper unit, top right side for the lower unit(as shown in the image)

### Emergency stop switch

This switch is used to stop the chamber manually in case of emergency

- Without a guard
- With a guard



With a guard

### Anchoring fixtures

This option uses for fixing the chamber to the floor.

\* Anchoring fixtures when installing the dew tray are also available.

### Chamber dew tray

A chamber dew tray is installed below the chamber in the unlikely case there would be water leakage.

Model	Size (W×H×D mm)
EHS-212 (M)	698×50×968
EHS-412 (M)	
EHS-222 (M)	798×50×1118
EHS-212MD	884×50×1198
EHS-412MD	
EHS-222MD	984×50×1198

### Operation manual

- CD
- Booklet

 Additional equipment can be added after purchasing the chamber.

# Network

## Chambers can be operated from PC and tablet

- Remote monitoring and control (Ethernet connection)**

The chambers are equipped with unique web applications that enable chamber status to be confirmed and operated from a web browser screen (PC or tablet terminal). It is also possible to start operations with a PC or other device from a remote location.



Image

- Editing test profiles through a browser**

It is possible to edit the test profiles registered in the chamber through a web browser.

- Displaying data in trend graph**

Settings and measured data saved in the chamber can be displayed in graphs on a web browser.

- E-mail notifications**

Details on alarms that have been triggered will be sent to pre-registered e-mail addresses. It is also possible to transmit e-mails when testing has finished.

\* An Intranet environment is required to transmit e-mails.

### Login privileges

Screen Privileges	Chamber monitor	Constant/Program setup	Run/Stop	Configuration
Administrator	✓	✓	✓	✓
Operator	✓	✓	✓	
User	✓			

- Email alert**

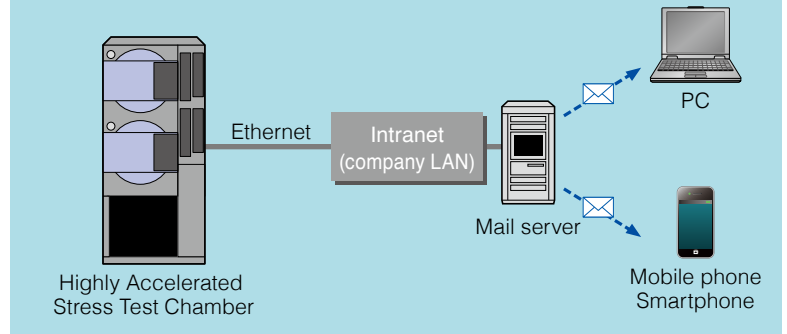

### ESPEC OnlineCore

# OnlineCORE (Sold separately)

Central control system recommended for multiple environmental test chambers installations

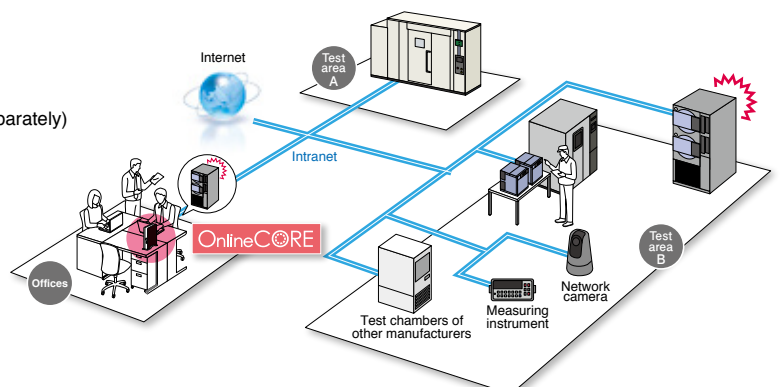

**ESPEC CORP.** <https://www.espec.co.jp/english>

**Head Office**

3-5-6, Tenjinbashi, Kita-ku, Osaka 530-8550, Japan  
Tel: 81-6-6358-4741 Fax: 81-6-6358-5500

**ESPEC NORTH AMERICA, INC.**

Tel: 1-616-896-6100 Fax: 1-616-896-6150

**ESPEC EUROPE GmbH**

Tel: 49-89-1893-9630 Fax: 49-89-1893-96379

**ESPEC ENVIRONMENTAL CHAMBERS**

**SALES AND ENGINEERING LTD. STI. (Turkey)**

Tel: 90-212-438-1841 Fax: 90-212-438-1871

**ESPEC ENVIRONMENTAL EQUIPMENT (SHANGHAI) CO., LTD.**

**Head Office**

Tel: 86-21-51036677 Fax: 86-21-63372237

**BEIJING Branch**

Tel: 86-10-64627025 Fax: 86-10-64627036

**GUANGZHOU Branch**

Tel: 86-20-83317826 Fax: 86-20-83317825

**SHENZHEN Branch**

Tel: 86-755-83674422 Fax: 86-755-83674228

**SUZHOU Branch**

Tel: 86-512-68028890 Fax: 86-512-68028860

**TIANJIN Branch**

Tel: 86-22-26210366 Fax: 86-22-26282186

**XI'AN Branch**

Tel: 86-29-88312908 Fax: 86-29-88455957

**CHENGDU Branch**

Tel: 86-28-88457756 Fax: 86-28-88474456

**ESPEC TEST TECHNOLOGY (SHANGHAI) CO., LTD.**

Tel: 86-21-68798008 Fax: 86-21-68798088

**ESPEC ENGINEERING (THAILAND) CO., LTD.**

Tel: 66-3-810-9353 Fax: 66-3-810-9356

**ESPEC ENGINEERING VIETNAM CO., LTD.**

Tel: 84-24-22208811 Fax: 84-24-22208822



**ISO 14001 (JIS Q 14001)**

**Environmental Management System Assessed and Registered**

ESPEC CORP.  
(Overseas subsidiaries not included)

- Specifications are subject to change without notice due to design improvements.
- Corporate names and trade names mentioned in this catalog are trademarks or registered trademarks.