



Advanced Test Equipment Rentals
www.atecorp.com 800-404-ATEC (2832)













Test and Inspection

FLX380 FlexTester3 Series

Quick Reference Guide



Functional Keys

Functional Keys

KEY	NAME	KEY FUNCTION
	Power	Press and hold (~1 second) to turn the FLX380 on or off.
	VFL	Visual Fault Locator (red laser): ON - Press and hold (~1 second) LED will flash. ON - Press and hold (~2 seconds) LED will be solid. OFF - Press and hold (~1 second) LED should be OFF.
	Menu	Press to access the Main Menu.
	Left & Right Tab keys	Press to display the next/previous available Menu Tab or Test View Tab.
	Arrow (Navigation) keys	The arrow keys provide several functions: <ul style="list-style-type: none"> • Main Menu: these keys are used to navigate menus and change setup parameters. • Trace Page: in the Zoom mode, these keys are used to adjust zoom. In the Move mode, Left and Right keys are used to move cursors.
	Select (A/B)	This key provides several functions: <ul style="list-style-type: none"> • Main Menu: press to display a submenu (if available). • Trace Page: press to toggle the active cursor between A and B.
	Back	Press once to return to the previous page. Press one or more times, depending on which menu or editor submenu is displayed, to return to the Main Menu.
	Test	Press to start or stop a test.
	Save	Provides several functions: save the currently displayed test results; set current folder; set current file name; review results.
	Soft keys (under display)	The label shown in the display above each soft key (F1, F2 or F3) indicates the current function for that key. Press to select the indicated function.

FLX380 FlexTester3 Test Modes

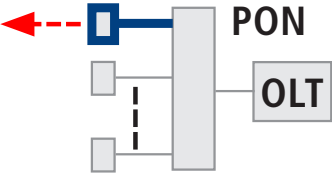
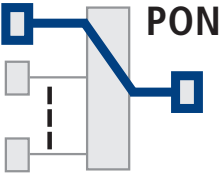
OTDR Modes

TEST MODE	NETWORK BEING TESTED	APPLICATIONS	SETUP
FTTx PON OTDR – Test Customer Fiber Only (to splitter)		PON power meter. Customer fiber fault location (fiber may be live or dark).	Auto
FTTx PON OTDR – Test Through Splitter		End-to-end length, loss, and ORL. Splitter loss. Feeder fiber fault location.	Semi-Auto
Full Auto (point-to-point)	Long-haul Metro Access 	Fault location. End-to-end length, loss, and ORL. Connector loss and reflection. Splice loss.	Auto
Real Time	Any	Short range fault location. First connector check. Fusion splice check. Mechanical splice tuning.	Semi-Auto
Expert	Any	Advanced point-to-point and FTTx PON. testing for experienced OTDR users.	Manual or Semi-auto

Light Source and Power Meter Mode

TEST MODE	APPLICATION
Light Source	<ul style="list-style-type: none"> • Measure end-to-end loss using manually set or Wave ID wavelength. • Trace fibers using tone generation and a NOYES Optical Fiber Identifier (OFI).
Power Meter	<ul style="list-style-type: none"> • Measure optical power or fiber loss using manually set or automatically detected (Wave ID) wavelength.

FLX380 FlexTester3 Main Menu Display Features

Main Menu Page (FLX380-303/-304 model shown)

Notes:

- FTTx PON OTDR combines functions of previous FTTx – In Service and FTTx – PON Construction modes.
- FTTx PON Power Meter measures downstream PON power levels in live PONs.
- Full Auto OTDR should only be used for point-to-point testing applications.



Page header.

Highlighted tab indicates the currently displayed Menu Page.

The currently highlighted Menu option.

Press [Files] to open saved files.

Note: After an OTDR test is started, it may take several seconds for the first results to appear and depending on setup, tens of seconds or even several minutes for tests to complete.

To Start a Test, press  **To Stop a Test** 

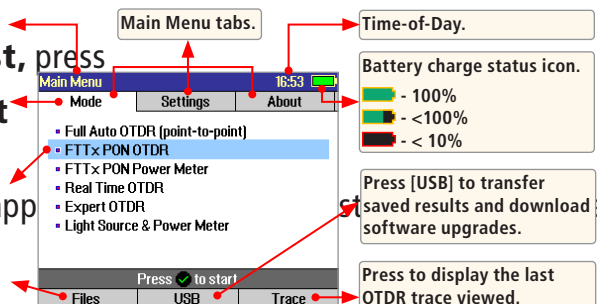

The screenshot shows the Main Menu interface with the following callouts:

- Main Menu tabs:** Points to the 'Main Menu', 'Settings', and 'About' tabs at the top.
- Time-of-Day:** Points to the '16:53' display.
- Battery charge status icon:** Points to the battery icon with a legend:
 - Green bar: - 100%
 - Yellow bar: - <100%
 - Red bar: - < 10%
- Press [USB] to transfer saved results and download software upgrades:** Points to the 'USB' button.
- Press to display the last OTDR trace viewed:** Points to the 'Trace' button.
- Press [Files] to open saved files:** Points to the 'Files' button.
- Press [Test key] to start:** Points to the 'Test key' button.

Press [Test key] to start **Press [Back key] to stop**

Press [USB] to transfer saved results and download software upgrades.

Press to display the last OTDR trace viewed.

 Test key.

Test key. If pressed before trace appears, it will stop the test and display the setup menu. If pressed

 Back key. OTDR stops the test and displays the setup menu.

Launch Quality Check

The FlexTester3 OTDR features an optional launch quality check when an OTDR test is initiated.

To perform the launch quality check:

1. From the Main menu, display the Settings screen (A) using keys.
2. Using keys navigate up/down the list to highlight the Launch Quality Check parameter (B).
3. If set to [Disabled], use keys to enable - display [Enabled].
4. With the launch quality check option enabled, press the Test key to start an OTDR test.
5. The FLS380-30 will assess the loss and reflectance at the OTDR's connection to the launch ring or fiber-under-test.
6. If excess loss or reflectance is detected, the OTDR reports results and displays the 'Poor Launch Quality' screen (C).
7. From the 'Poor Launch Quality' screen (C) the user may chose to perform one of the following:
8. Cancel a test by pressing Cancel (D) soft key or Back key .
9. Clean connectors and repeat the launch quality check by pressing Re-check soft key (E) or Enter key .
10. Continue testing without checking and cleaning the connection by pressing Test soft key (F) or Test key.

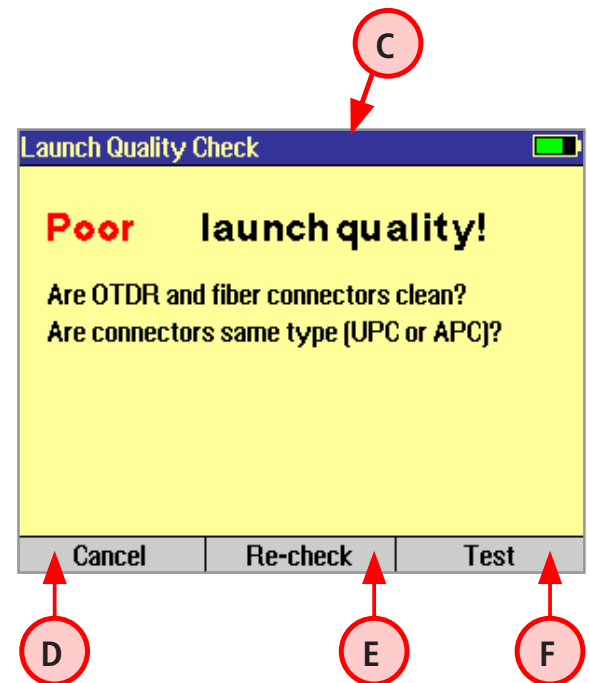
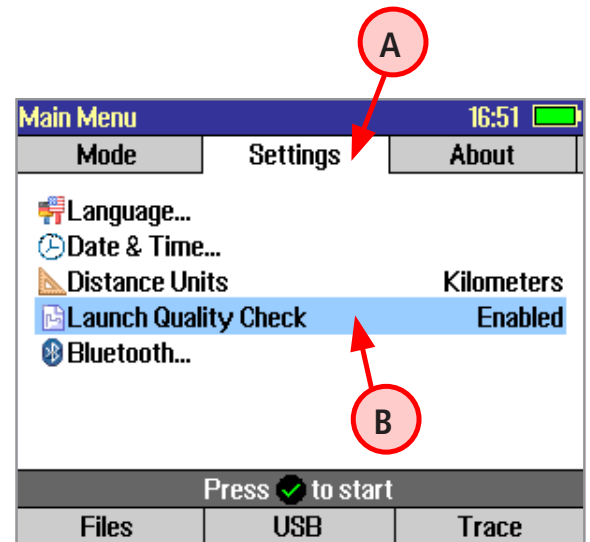

Test Settings: General OTDR Test Modes

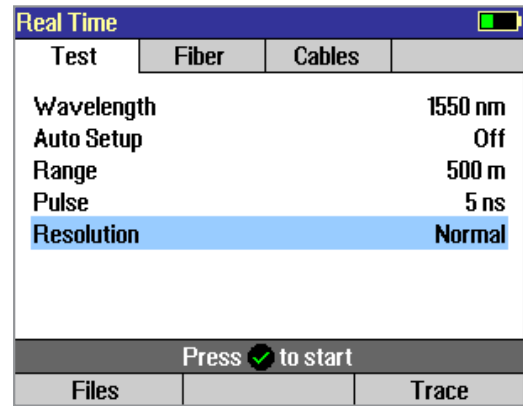
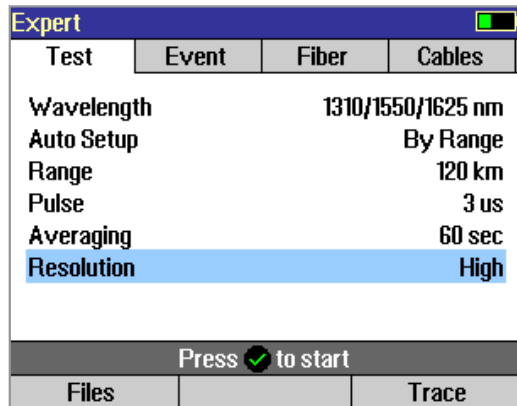

Setup Parameter	General-Purpose OTDR Test Mode		
	Full Auto	Real Time	Expert
Wavelength	User selects single or multiple wavelength(s) at which to test.		
Auto Setup	N/A (not applicable)	[Off]: User sets all parameters manually. [By Range]: User sets [Range] & [Resolution], [Pulse width] & [Averaging] selected automatically.	
Range	N/A: automatic	User sets OTDR scan range.	
Pulse width	N/A: automatic, based on auto-detected range	Automatic if [Auto Setup] parameter is set to [By Range] option. User-set if [Auto Setup] parameter is set to option [Off].	
Averaging		N/A: 1 second updates	Automatic if [Auto Setup] is set to [By Range]. User-set if [Auto Setup] is set to [Off].
Resolution	N/A: automatic	User-set [High] or [Normal].	

Range: When setting manually, select [Range], which is at least 20% longer than the fiber under test.

Pulse width [Pulse]: Select wider pulse widths to obtain cleaner traces (less noisy). Select narrower pulse widths to detect events which are close together (better resolution).

Averaging Time [Averaging]: Longer averaging times produce cleaner traces.

Resolution: [High] resolution provides close data spacing for more precise event location and better detection of closely spaced events. [Normal] resolution uses more filtering to provide a cleaner trace, but with lower resolution.

Test Settings: FTTx PON OTDR Test Mode

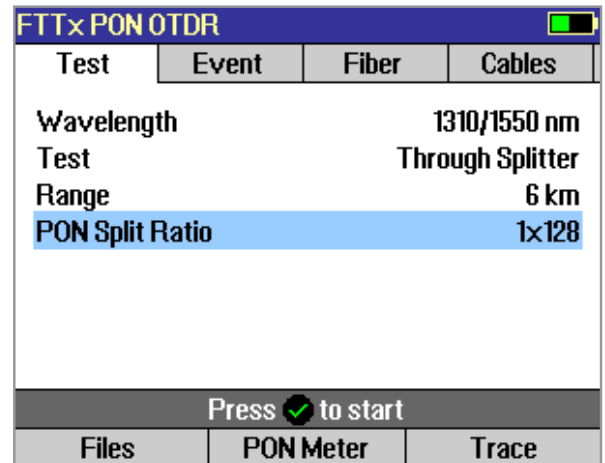
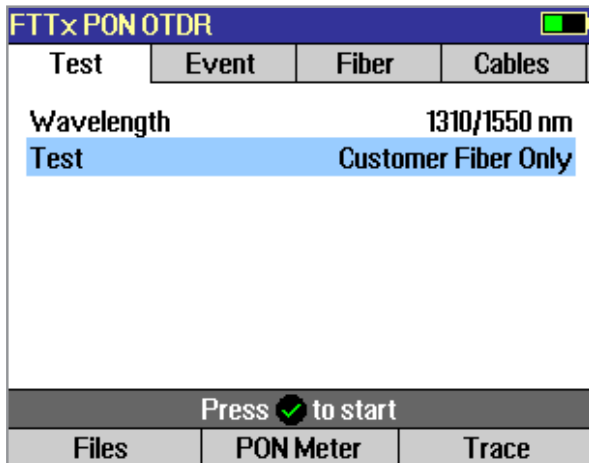

Parameter	FTTx PON OTDR Test Mode
Wavelength	User selects single or multiple wavelength(s) at which to test.
Range	Auto: Range, pulse width, resolution, averaging are automatically determined. Distance settings: User manually selects setting in range 250 m to 240 km.
Test	If set to [Customer Fiber Only], tests only to the splitter using automatically determined Range setting. If set to [Through Splitter], tests through splitter including customer and feeder fibers using selected automatic or manual range setting.
PON	Not present if [Test] parameter is set to [Customer Fiber Only] option. If [Test] is set to [Through Splitter], user sets PON split ratio (1x8, 1x16, x132, 1x64, or 1x128).

Range: When setting manually, select [**Range**], which is at least 20% longer than the fiber under test.

Pulse width [Pulse]: If testing through splitter, pulse width is set automatically based on [**Range**] and [**PON**] split ratio. If testing customer drop fiber only (In Service), automatically set based on range to splitter.

When testing through a splitter, user can force a wider pulse width to improve trace quality by selecting a longer [**Range**] or higher [**PON**] split ratio.

Averaging Time: Also set automatically.

Resolution: Since PONs are usually short, resolution is typically set to High (close data spacing) for more precise event location.

OTDR Mode: Trace Page Features

Trace Page displays OTDR trace, A/B cursors, Loss, Distance, and max reflectance between A and B cursors.

File name (cable name + fiber number), or "New Trace" if file has not been saved.

Event Table displays OTDR event measurements.

Summary Page displays end-to-end link measurements.

Test Wavelengths (RED is current).

Grid units display dB/div on vertical axis and distance/div on horizontal axis.

Information Page displays OTDR setup parameters, launch and receive cable data, and event thresholds.

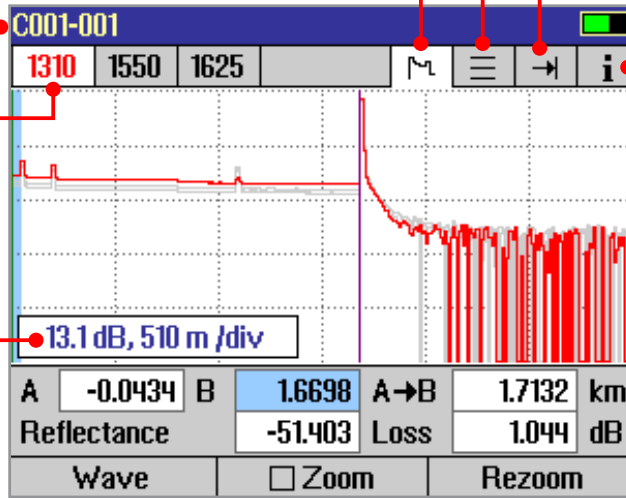

Fiber under test.

Launch cable (if present).

A and B cursors.

Trace graph (RED is current).

Receive cable (if present).

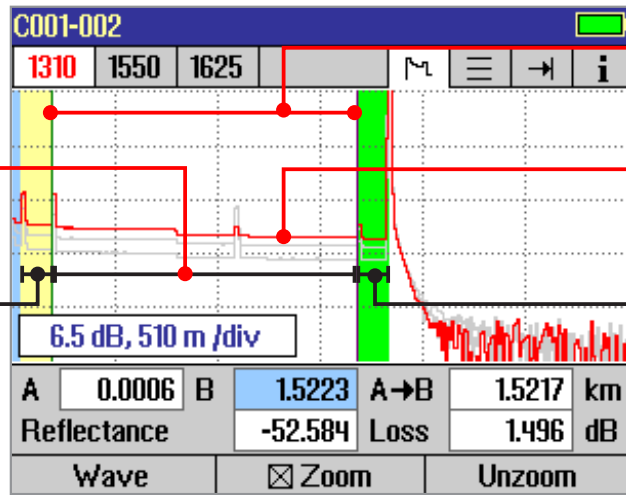

Soft key labels
(see next page for details)

OTDR Mode: Trace Page Features

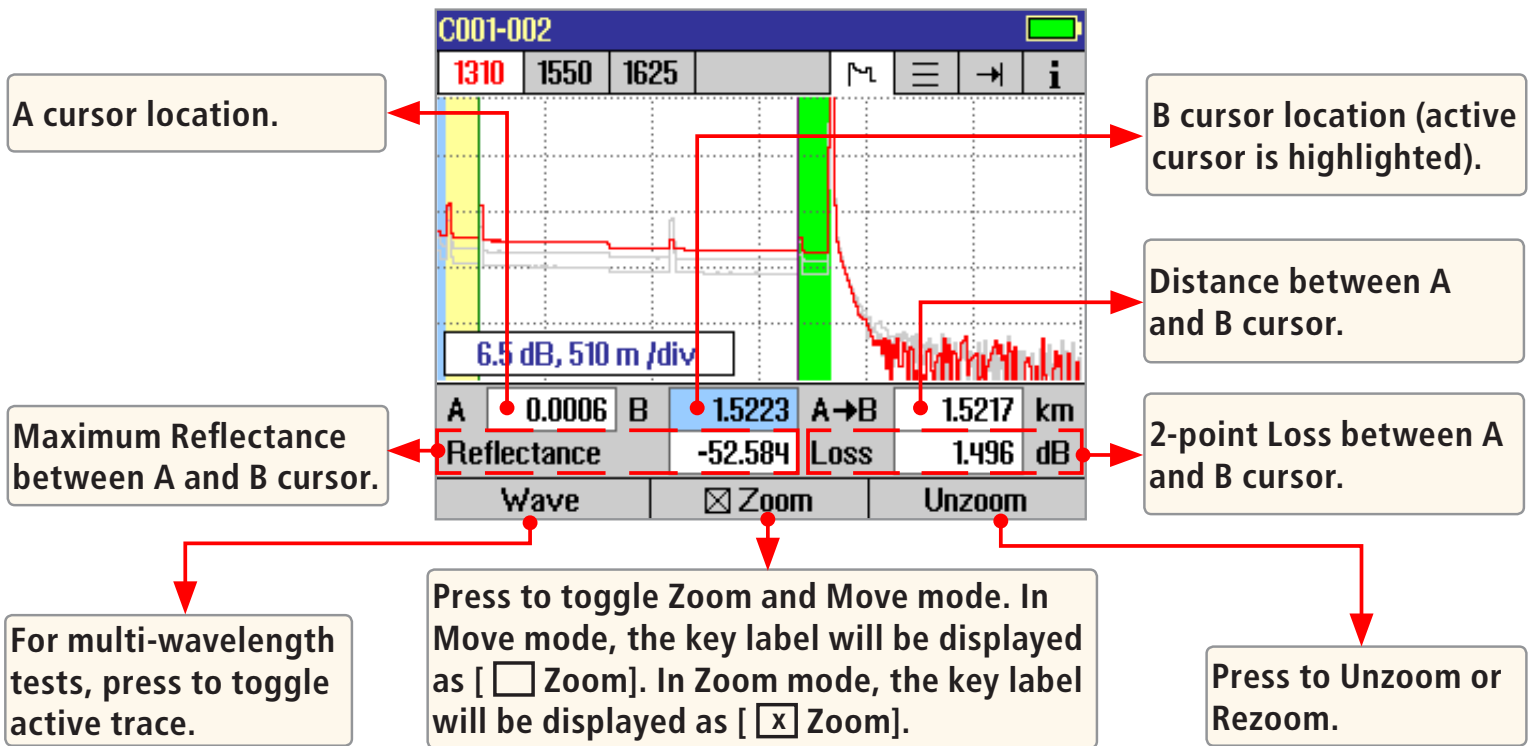

Navigation Keys

Zoom mode

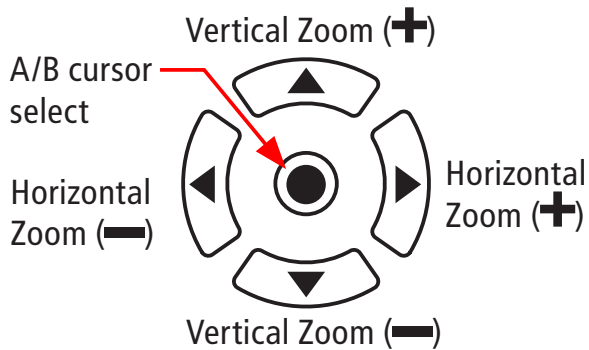

Move mode

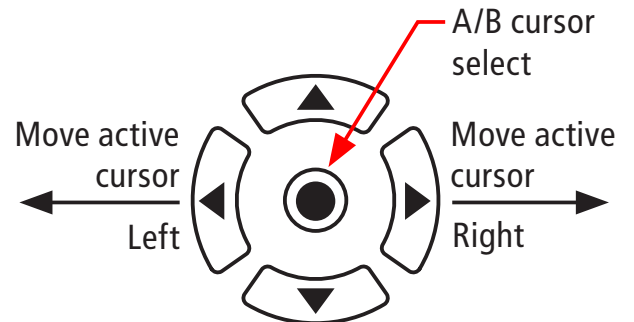

Note: Zoom expands/shrinks the trace around the currently active cursor.

OTDR Mode: Event Table Page Features

Event Table is automatically generated when the [Events] are set to [Auto] in the OTDR Event settings display.

Trace Graph.

Event Table displays:
[Number] of each event, event [Location] in user selected units, event [Type], [Reflectance] and [Loss] in (dB) and loss/distance (dB/km).



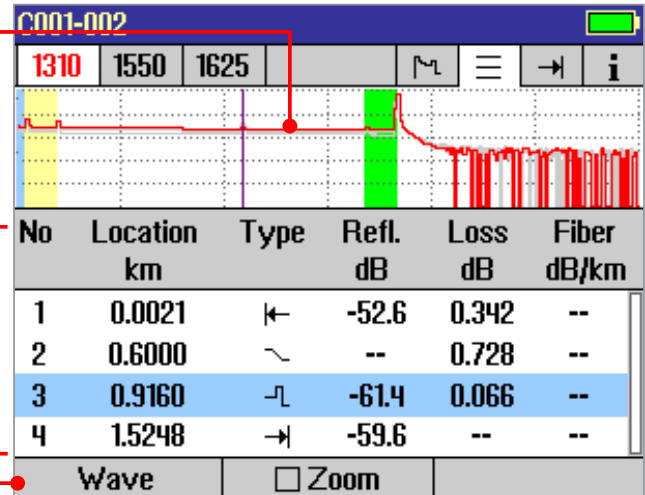

For multiple-wavelength tests, press to toggle the wavelength and display event table for that wavelength.



Event Types

ICON	EVENT TYPE	DESCRIPTION
←	Start	The start of the fiber under test.
→	End	The end of the fiber under test.
↘	Non-reflective Loss Event	An event with measurable loss but very small or unmeasurable reflectance, typically caused by a fusion splice, fiber break, or macrobend (with macrobend detection disabled).
↗	Non-reflective Gainer Event	An event with 'negative loss,' which can occur in OTDR traces where two fibers with very different backscatter coefficients are spliced or connected. A gainer will be seen as a normal (positive loss) event when tested from the other end of the fiber. The true loss of the event is approximately equal to the average of its loss measured from each end of the fiber under test.
↖	Reflective Event	An event with measurable loss and reflectance, typically caused by a connection or mechanical splice.

OTDR Mode: Event Table Page Features

ICON	EVENT TYPE	DESCRIPTION
	Macrobend	A non-reflective loss event with significantly higher loss at longer wavelengths (1550, 1625, 1650 nm) than seen at shorter wavelengths (1310, 1490 nm). Typically caused by a sharp bend in the fiber.
	Splitter	PON splitters are detected only when Event thresholds are set to PON Default or PON User and a high loss event (> 6 dB) is detected which is determined not to be the end of the fiber.
	Group Start Event	First event in multiple event group. Reports loss of entire group. Reports reflectance of first event in group if reflectance of next event can be independently measured. Reports max reflectance of grouped events if next reflectance cannot be independently measured.
	Group Middle Event	Grouped events may contain zero, one, or more middle events. Loss of middle events is included in group loss reported in the group start event. Reports reflectance if it can be independently measured.
	Group End Event	Last event in a multiple event group. Loss of last event is included in group loss reported in group start event. Reports reflectance if it can be independently measured.

OTDR Mode: Summary Page Features

Summary page displays:
trace graph, fiber under test [Length] in user selected units, [Loss] and [ORL] in (dB).

For multiple-wavelength tests, press to toggle the wavelength and display [Length], [Loss] and [ORL] test results for that wavelength.

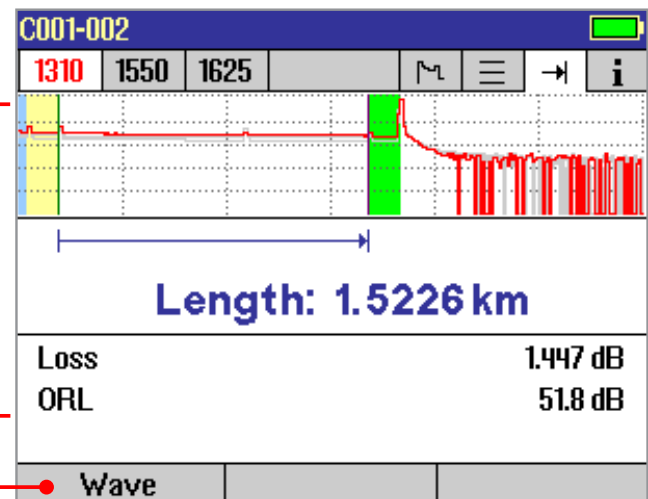

OTDR Mode: Information Page Features

The information page displays how the test was created.

- Use ▲▼ keys to highlight the desired setup parameter.
- Use ◀▶ keys to change the highlighted setup parameter (except [Event Thresholds...] parameter). You may change these parameters to correct locations in the Event Table after the test is complete.
- When done, press [Recalc Events] to recalculate the Event Table.

- Press ● key to display submenu **A**.
- Use ▲▼ keys to highlight the desired parameter.
- Use ◀▶ keys to change the highlighted parameter.
- When done, press [Recalc Events] to recalculate the Event Table.

These fields show the current setup conditions.

For multiple-wavelength tests, press to toggle the wavelength and display setup conditions for that wavelength.

Event thresholds can be adjusted and macrobend detection enabled or disabled before recalculating events.

The screenshot shows the OTDR Information Page for test C001-007. The top section displays test parameters: Launch Cable (0.1500 km), Receive Cable (0.0000 km), Group Index of Refraction (1.46900), and Backscatter Coefficient (-83.0 dB). Below this is the 'Event Thresholds...' section, which is highlighted. A red circle with the letter 'A' is positioned over the 'Event Thresholds...' header. The 'Event Thresholds' submenu is shown below, listing parameters: Group (User), End Loss (dB) (3.0), Event Loss (dB) (0.10), Event Reflectance (dB) (-65.0), and Macrobend Detection (Enabled). A red circle with the letter 'A' is also positioned over the 'Event Thresholds' header in this submenu. At the bottom of the submenu is a 'Recalc Events' button. Red arrows point from the text boxes on the left to the corresponding elements in the screenshot.

Mode	FTT× PON	Pulse Width	30 ns
Range	3.00 km	Time	30 sec
Resolution	High	Averages	2048

Group	User
End Loss (dB)	3.0
Event Loss (dB)	0.10
Event Reflectance (dB)	-65.0
Macrobend Detection	Enabled

Saving Test Results

File Manager System

The FLX380 File Manager system consists of four pages:

PAGE NAME	DESCRIPTION AND FUNCTION
Jobs	Lists the Jobs (folders) stored in the FLX380 internal memory. Use to open or delete the highlighted job folder.
Cables	Lists the Cables (folders) in the currently open Job folder. Use to open or delete the highlighted cable folder.
Results	Lists the OTDR trace (.SOR) files and OPM results (.ATD) files in the currently open Cable folder. Use to open (view) or delete the highlighted results file.
Save As	Lists the current job, the current cable, and the fiber number that will be used the next time a group of traces is saved. Use to save the 'new' results created by the most recent test, or the results most recently opened (recalled from memory).

File Manager - Jobs Page

The screenshot shows the File Manager interface with the following callouts:

- List of saved Jobs (folders).** Points to the list of folders: DSM,44FPAWS2; FSM,45FPAWS2; JOB000000001; JOB000000002; PONTEST00001; QRGDATABASE0.
- Highlighted Job folder.** Points to the JOB000000001 folder, which is highlighted in blue.
- Free space (internal memory).** Points to the 99% indicator in the bottom right corner.
- Press to open the highlighted Job (which becomes the current job) and see a list of the cables stored in this job.** Points to the Open button.
- Press to delete the highlighted Job folder.** Points to the Delete button.
- Press to display the Save As page.** Points to the Save As button.
- This field shows X/Y: X = number of the highlighted job Y = total number of jobs in FLX380 memory.** Points to the 3/6 indicator.

Saving Test Results

File Manager - Cables Page

Select (▲ ..) to return to Jobs page.

This field shows X/Y:
X = number of the highlighted cable
Y = total number of cables in the current job.

Press to display the Save As page.

Press to delete the highlighted Cable folder

List of saved Cables (folders).

Highlighted Cable folder.

Free space (internal memory).

Press to open the highlighted cable (which becomes the current cable) and see a list of trace (.SOR) and OPM (.ATD) files stored for this cable.

The screenshot shows a File Manager window with a list of folders: END100-END200-C001, END100-END200-C002, END100-END200-C003, and END100-END200-C004. The third folder is highlighted. Below the list, the status bar shows 'Job: QRGDATABASE0' and 'Cable:'. A progress indicator shows '3/4' and '99%'. At the bottom are buttons for 'Save As', 'Delete', and 'Open'. A back arrow is at the top left.

File Manager - Results Page

Select (▲ ..) to return to Cables page.

This field shows X/Y:
X = number of the highlighted results file
Y = total number of results files in the current cable.

Press to display the Save As page.

Press to delete the highlighted trace or OPM results file.

List of saved results (OTDR .SOR and OPM .ATD files).

Highlighted trace.

Free space (internal memory).

Press to open the highlighted trace or OPM result. Opening the selected trace file will open traces for all wavelengths having the same fiber number.

The screenshot shows a File Manager window with a list of files: END100-END200_001_S13, END100-END200_001_S15, END100-END200_001_S16, END100-END200_002_S13, END100-END200_002_S15, and END100-END200_002_S16. The third file is highlighted. Below the list, the status bar shows 'Job: QRGDATABASE0' and 'Cable: END100-END200-C001'. A progress indicator shows '3/6' and '99%'. At the bottom are buttons for 'Save As', 'Delete', and 'Open'. A back arrow is at the top left.





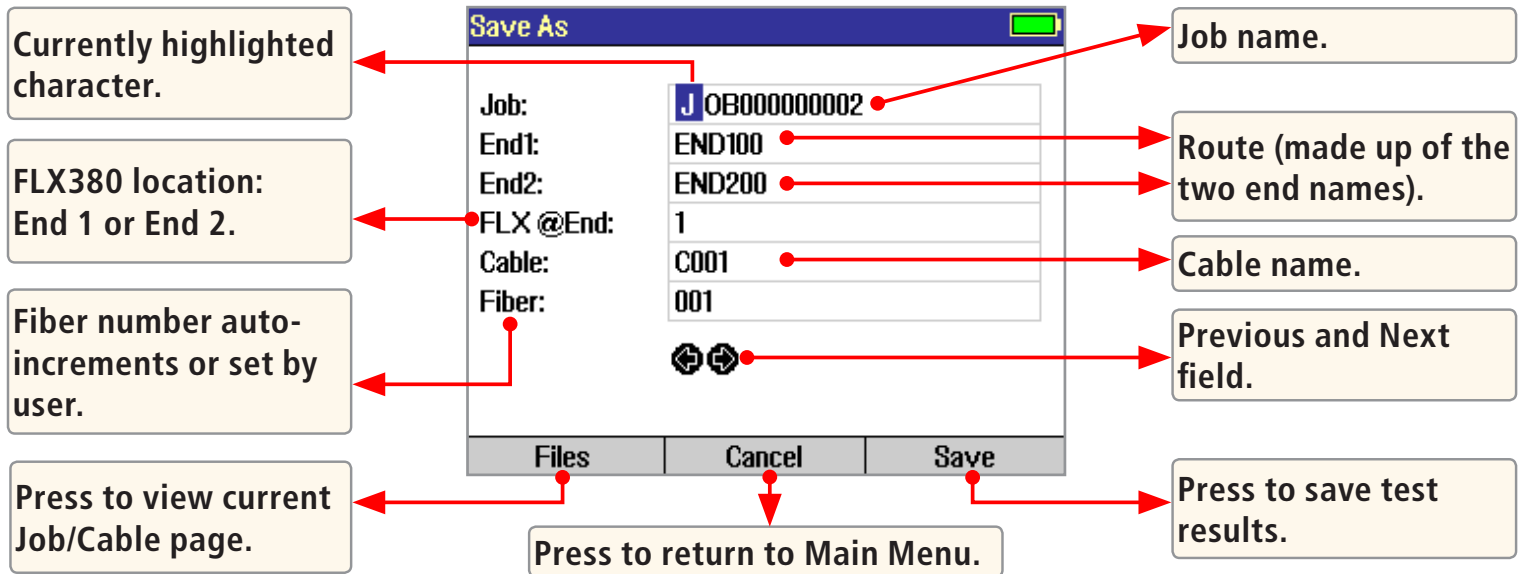

Saving Test Results

File Manager - Save As Page



Saving Results

- Once a test is complete, press the Save key  to display the [Save As] page.
- Perform the following steps to save to an existing Job/Cable folder or save to a new folder:

EXISTING FOLDER	NEW FOLDER
<ul style="list-style-type: none"> Press the [Save] soft key to save test results with the currently displayed Job, Route, Cable and Fiber number. 	<ul style="list-style-type: none"> Use   keys to select the previous / next field to edit. Use   keys to highlight any character position within the Job/End1/End2/Cable name fields and Fiber number field. Use   keys to change the highlighted character. <ul style="list-style-type: none"> If the Job/End1/End2/Cable name and Fiber number are edited to a name and number that already exists in the current folder, then pressing the [Save] key will cause the FLX380 to display "Overwrite file?". If the Job/End1/End2/Cable name is edited to a new name, then pressing the [Save] key will cause the FLX380 to create a new folder of this name. Note: This is the only way to create new folders! When done, press the [Save] soft key.

Light Source and Power Meter Test Mode

Use ▲▼ keys to navigate Light Source menu.

Use ◀▶ keys to change Light Source menu items.

The screenshot shows the 'Light Source and Power Meter' interface. It is divided into two main sections: 'SOURCE' and 'METER'. The 'SOURCE' section includes 'Laser' (On), 'Mode' (Wave ID), and 'Wavelength' (1310/1550 nm). The 'METER' section shows 'Wave ID' (circled in red with 'A'), '1310nm', '1550nm', and '-1.21 dBm'. Below the meter, there are buttons for 'dB/dBm/W', 'Ref/Set', and 'λ'. A red asterisk is in the top right corner. Callouts point to various elements: 'Turn laser On/Off.' points to the Laser status; 'Select test mode: CW, 270 Hz, 330 Hz, 1 kHz and 2 kHz tones, or Wave ID.' points to the Mode; 'Select wavelength(s).' points to the Wavelength; 'Press to toggle units: • dB to measure loss, • dBm or W to measure power' points to the dB/dBm/W button; 'Hold to set OPM reference level. Press briefly to see current reference levels.' points to the Ref/Set button; 'Press to toggle OPM wavelength.' points to the λ button. Brackets on the right group 'Light Source settings' (SOURCE section) and 'Power Meter settings' (METER section).

Wave ID Mode Feature

The Wave ID (automatic wavelength identification) feature significantly increases efficiency:

- Cuts test time in half (or more) by testing multiple wavelengths simultaneously.
- Eliminates user setup error and the need to coordinate manual setting of wavelengths by users located at opposite ends of the fiber under test.

The "Wave ID" field **A** to the left of the displayed Power Meter wavelength will display one of the following:

- 270 Hz, 330 Hz, 1 kHz, 2 kHz, or Wave ID. If none of these are detected, this OPM field is blank.
- When Wave ID is displayed, Power or loss is measured and displayed for the automatically detected wavelengths.
- In other modes, the wavelength must be manually set but tone frequency is automatically detected.

FTTx PON Power Meter (FLX380-303 and FLX380-304 models only!)

FLX380-303 and -304 support AFL's ServiceSafe™ capability (US patent 8,411,259), enabling both in-service and out-of-service OTDR testing and live PON power measurements to be made from a single port. In the FTTx PON Power Meter mode, the first screen displays received FTTx PON power at 1490 and 1550 nm. An OTDR test can be initiated from the PON Power Meter mode. On dark fibers, users can test at 1310/1550 nm. On live fibers, users can test at only 1625 nm or 1650 nm.

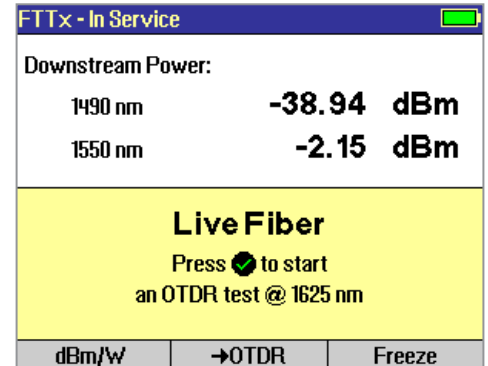
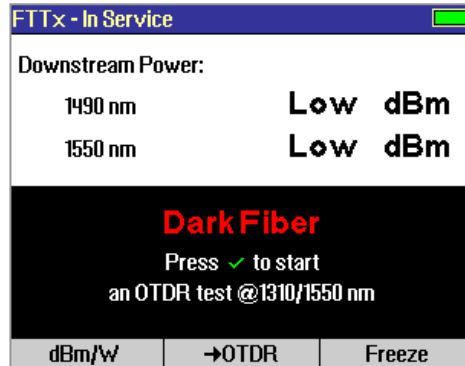

Transferring Files to a PC using USB

To transfer files from your FLX380 to a PC using a USB cable, perform the following:

- 1 Connect your FLX380 to a PC using the supplied type A to Mini USB cable. Make sure the mini-plug is fully seated in your FLX380.
- 2 Press the [USB] soft key on the FLX380's Main Menu.
- 3 From your PC desktop, open My Computer. A new removable drive named [OFL X:] will appear, where 'X:' is the drive letter assigned to your FLX380 by the PC.
- 4 Under [OFL X:] you should see two folders: [RESULTS] and [SOFTWARE]. Copy the [RESULTS] folder to your PC.
- 5 Under [RESULTS] you will see: [TRACES]. Under [TRACES] you will see all of the folders containing OTDR traces or OPM results.

Note: Before removing the USB cable connecting your FLX380 to your PC, or pressing the [Cancel] soft key on the USB page, left click the Safely Remove Hardware icon in the Start bar of your PC, then left click the Safely Remove USB mass storage device – Drive (X:) message, where 'X' is the drive letter assigned to your FLX380. For detailed operating instructions, refer to the FLX380 User's Guide (available on supplied CD and www.AFLglobal.com).



Test and Inspection

Thank you for choosing NOYES Test and Inspection!



NOYES[®]

www.AFLglobal.com or +1 (800) 321-5298, +1 (603) 528-7780