

Provided by:



**Advanced Test  
Equipment Corp.**

**www.atecorp.com  
(800) 404-ATEC**

Rentals • Sales • Calibration • Service



**L3HARRIS**

**narda**   
Safety Test Solutions

**NARDA  
Safety  
Test  
Solutions**  
S.r.l. Socio Unico

<http://www.narda-sts.it>

**Sales & Support:**

Via Rimini, 22  
20142 - Milano (MI)  
Tel.: +39 02 581881  
Fax: +39 02 58188273

**Manufacturing Plant:**

Via Benessea, 29/B  
17035 - Cisano sul Neva (SV)  
Tel.: +39 0182 58641  
Fax: +39 0182 586400



# User's Manual

## EHP-50F

### ELECTRIC AND MAGNETIC FIELD PROBE - ANALYZER

From 1 Hz up to 400 kHz

#### **SERIAL NUMBER OF THE INSTRUMENT**

You can find the Serial Number on the bottom cover of the instrument.  
The Serial Number is in the form: 000XY00000.

The first three digits and the two letters are the Serial Number prefix, the last five digits are the Serial Number suffix. The prefix is the same for identical instruments, it changes only when a configuration change is made to the instrument.  
The suffix is different for each instrument

**Document EHP50FEN-10107-1.73 – Copyright © NARDA 2021**

**NOTE:**

© Names and Logo are registered trademarks of Narda Safety Test Solutions GmbH and L3 Communications Holdings, Inc. – Trade names are trademarks of the owners.

If the instrument is used in any other way than as described in this User's Manual, it may become unsafe



Before using this product, the related documentation must be read with great care and fully understood to familiarize with all the safety prescriptions.

To ensure the correct use and the maximum safety level, the User shall know all the instructions and recommendations contained in this document.

This product is a **Safety Class III** instrument according to IEC classification and has been designed to meet the requirements of EN61010-1 (Safety Requirements for Electrical Equipment for Measurement, Control and Laboratory Use).



In accordance with the IEC classification, the battery charger of this product meets requirements **Safety Class II** and **Installation Category II** (having double insulation and able to carry out mono-phase power supply operations)..

It complies with the requirements of **Pollution Class II** (usually only non-conductive pollution). However, occasionally it may become temporarily conductive due to condense on it.

The information contained in this document is subject to change without notice.

**KEY TO THE ELECTRIC AND SAFETY SYMBOLS:**

You now own a high-quality instrument that will give you many years of reliable service. Nevertheless, even this product will become obsolete. When that time comes, please remember that electronic equipment must be disposed of in accordance with local regulations. This product conforms to the WEEE Directive of the European Union (2002/96/EC) and belongs to Category 9 (Monitoring and Control Instruments). You can return the instrument to us free of charge for proper environment friendly disposal. You can obtain further information from your local Narda Sales Partner or by visiting our website at [www.narda-sts.it](http://www.narda-sts.it).



Warning, danger of electric shock



Earth



Read carefully the Operating Manual and its instructions, pay attention to the safety symbols.



Unit Earth Connection



Earth Protection



Equipotential

**KEY TO THE SYMBOLS USED IN THIS DOCUMENT:**



**DANGER**

The **DANGER** sign draws attention to a potential risk to a person's safety. All the precautions must be fully understood and applied before proceeding.



**WARNING**

The **WARNING** sign draws attention to a potential risk of damage to the apparatus or loss of data. All the precautions must be fully understood and applied before proceeding.



**CAUTION**

The **CAUTION** sign draws attention against unsafe practices for the apparatus functionality.



**NOTE:**

The **NOTE** draw attention to important information.

# Contents

<b>Safety requirements and instructions.....</b>	<b>Page</b> VI
<b>EC Declaration of Conformity .....</b>	VII
<b>1 General information</b>	<b>Page</b>
1.1 Documentation.....	1-1
1.2 Introduction .....	1-1
1.3 Configuration and Standard accessories.....	1-3
1.4 Optional accessories .....	1-3
1.5 EHP-50F Main specifications.....	1-4
1.6 Isotropic E&H field analyzer EHP-50F typical uncertainty and Anisotropy.....	1-5
1.6.1 Measurements uncertainty of EHP-50F.....	1-5
1.6.2 Explication Notes.....	1-6
1.6.3 Measurements uncertainty of EHP-50F (Weighted Peak mode)...	1-7
1.7 Anisotropy.....	1-8
1.8 Overload level.....	1-11
1.9 EHP-50F panel.....	1-12
<b>2 Installation and use</b>	<b>Page</b>
2.1 Introduction.....	2-1
2.2 Preliminary inspection.....	2-1
2.3 Work Environment.....	2-1
2.4 To return for repair.....	2-1
2.5 Equipment cleaning.....	2-1
2.6 Power supply and battery recharging.....	2-2
2.7 EHP-50F connected to a PC.....	2-3
2.8 EHP-50F stand-alone mode.....	2-3
2.9 EHP-50F with NBM-550.....	2-3
2.10 Battery management.....	2-3
2.11 Avoiding measurement errors.....	2-4
<b>3 EHP50-TS installation</b>	<b>Page</b>
3.1 Introduction.....	3-1
3.2 Hardware requirements.....	3-1
3.3 Installing EHP50-TS Software.....	3-2
<b>4 EHP50-TS software</b>	<b>Page</b>
4.1 EHP50-TS Applications.....	4-1
4.2 EHP-50F Installation.....	4-2
4.2.1 Main menu.....	4-2
4.3 Mode section.....	4-4
4.4 Span section.....	4-5
4.5 Standard.....	4-7
4.6 Data section.....	4-9
4.6.1 Waterfall.....	4-13
4.6.1.1 Data recording.....	4-17
4.7 Style section.....	4-18
4.8 ICNIRP.....	4-19
4.9 IEEE.....	4-21
4.10 Weighted Peak Function (Time Domain).....	4-23
4.10.1 Weighted Peak requirements.....	4-23
4.10.2 EHP-TS Settings.....	4-24
4.10.3 Weighted Peak Mode.....	4-25
4.10.3.1 Noise indication.....	4-27

<b>5 EHP-50F Stand-alone mode</b>	<b>Page</b>
5.1 Stand-alone mode description.....	5-1
5.2 EHP-50F Data Logger.....	5-2
5.2.1 Run EHP-50F Stand-alone mode software.....	5-2
5.2.2 Use EHP-50F Logger.....	5-5
5.2.3 EHP-50F battery charging.....	5-5
<b>6 Update Firmware</b>	<b>Page</b>
6.1 Update firmware.....	6-1
6.2 To run the update software.....	6-1
6.3 To transfer data .....	6-1
<b>7 Uninstalling software</b>	<b>Page</b>
7.1 Uninstalling EHP-TS Software .....	7-1
<b>8 Uninstalling USB-OC</b>	<b>Page</b>
8.1 Uninstalling driver for USB-OC.....	8-1
<b>9 Accessories</b>	<b>Page</b>
9.1 Introduction.....	9-1
9.1.1 Preliminary inspection.....	9-1
9.1.2 Work environment.....	9-1
9.1.3 Return for repair.....	9-1
9.1.4 Cleaning.....	9-1
9.1.5 Power supply and battery chargers.....	9-2
9.2 NBM-550 Controller and display Unit for EHP-50F.....	9-3
9.3 USB-OC Optical USB Converter.....	9-5
9.3.1 Introduction.....	9-5
9.3.2 Installation.....	9-5

## Figures

Figure		Page
1-1	Block Diagram of the EHP-50F .....	1-2
1-2	3D mesh measurements of magnetic probe.....	1-8
1-3	EHP-50F axes.....	1-9
1-4	Overload level EHP-50F (B Field, RMS).....	1-11
1-5	Overload level EHP-50F (E Field, RMS).....	1-11
1-6	EHP-50F panel .....	1-12
3-1	EHP50-TS Installation.....	3-2
4-1	EHP50-TS Main Window.....	4-2
4-2	Defining frequency band through the PC mouse	4-5
4-3	Zoom window.....	4-6
4-4	Data section.....	4-9
4-5	Waterfall - Graph 2D.....	4-13
4-6	Waterfall Main Window.....	4-14
4-7	Waterfall - Graph 3D.....	4-15
5-1	Shorting loop.....	5-1
6-1	EHP-50F Upgrading Utility Main Window.....	6-1
7-1	Uninstalling EHP50-TS.....	7-1
8-1	Uninstalling USB-OC.....	8-2
9-1	NBM-550.....	9-3
9-2	NBM-TS software.....	9-3
9-3	Monitor Mode.....	9-4
9-4	XYZ Mode.....	9-4
9-5	Spectrum Mode.....	9-4
9-6	Standard Mode (ICNIRP) .....	9-4
9-7	Weighted Peak Mode.....	9-4
9-8	Weighted Peak Marker.....	9-4
9-9	USB-OC Adapters.....	9-5

## Tables

Table		Page
1-1	Technical Specifications of the EHP-50F.....	1-4
2-1	Autonomy of the battery.....	2-3
9-1	Technical Specifications of the USB-OC.....	9-5



## **SAFETY RECOMMENDATIONS AND INSTRUCTIONS**

This product has been designed, produced and tested in Italy, and it left the factory in conditions fully complying with the current safety standards. To maintain it in safe conditions and ensure correct use, these general instructions must be fully understood and applied before the product is used.

- In case of devices permanently connected to the power supply, and lacking any fuses or other devices of mains protection, the power line must be equipped with adequate protection commensurate to the consumption of all the devices connected to it;
- Devices in Safety Class I, equipped with connection to the power mains by means of cord and plug, can only be plugged into a socket equipped with a ground wire;
- Any interruption or loosening of the ground wire or of a connecting power cable, inside or outside the device, will cause a potential risk for the safety of the personnel;
- Ground connections must not be interrupted;
- To prevent the possible danger of electrocution, do not remove any covers, panels or guards installed on the device, and refer only to NARDA Service Centers if maintenance should be necessary;
- To maintain adequate protection from fire hazards, replace fuses only with others of the same type and rating;
- Follow the safety regulations and any additional instructions in this manual to prevent accidents and damages.

# Dichiarazione di Conformità *EC Declaration of Conformity*



In accordo alla Decisione 768/2008/EC, conforme alle direttive EMC 2014/30/UE, Bassa Tensione 2014/35/UE e RoHS 2011/65/UE, ed anche alle norme ISO/IEC 17050-1 e 17050-2.

*In accordance with the Decision 768/2008/EC, compliant to the Directives EMC 2014/30/EU, Low Voltage 2014/35/EU and RoHS 2011/65/EU, also compliant to the ISO/IEC standard 17050-1 and 17050-2*

Il costruttore  
*The manufacturer*

**narda Safety Test Solutions S.r.l. Socio Unico**

Indirizzo  
*Address*

**Via Benessea, 29 / B**

**I-17035 Cisano sul Neva (SV) - Italy**

**sulla base delle seguenti norme europee armonizzate, applicate con esito positivo:  
*based on the following harmonized European Standards, successfully applied:***

EMC - Emissioni:  
*EMC - Emission:* **EN 61326-1 (2013)**

EMC - Immunità:  
*EMC - Immunity:* **EN 61326-1 (2013)**

Sicurezza:  
*Safety:* **EN 61010-1 (2010)**

**dichiara, sotto la propria responsabilità, che il prodotto:  
*declares, under its sole responsibility, that the product:***

Descrizione  
*Description* **SONDA ANALIZZATORE DI CAMPO ELETTRICO E MAGNETICO  
*ELECTRIC AND MAGNETIC FIELD PROBE - ANALYZER***

Modello  
*Model* **EHP-50F**

**è conforme ai requisiti essenziali delle seguenti Direttive:  
*conforms with the essential requirements of the following Directives:***

Bassa Tensione  
*Low Voltage* **2014/35/EU**

Compatibilità Elettromagnetica  
*EMC* **2014/30/EU**

RoHS  
*RoHS* **2011/65/EU**

Cisano sul Neva, 20 April 2016

Egon Stocca  
General Manager

**This page has been left blank intentionally**



# 1 - General information

## 1.1 Documentation

The following documents are included in this Manual:

- A questionnaire to be sent to NARDA together with the apparatus should service be required.
- A checklist of the Accessories included in the shipment.

This Manual includes description of EHP-50F standard and optional accessories.

## 1.2 Introduction



This section provides a general overview of EHP-50F Electric and Magnetic Field Analyzer.

EHP-50F is a low frequency electric and magnetic isotropic field probe-analyzer. It provides an advanced technology solution for field analysis in the 1 Hz to 400 kHz frequency range in an extremely high dynamic range. It includes X, Y and Z axes simultaneous measurements with a powerful, built in, spectrum analyzer.

EHP-50F can be used either connected to NBM-550 portable field meter or PC. Additionally, stand alone operation mode is provided for up to 24 hours continuous data collection.

EHP-50F includes a non volatile memory which stores frequency and level calibration tables and an internal optical repeater which allows connection to external devices through the optical fiber.

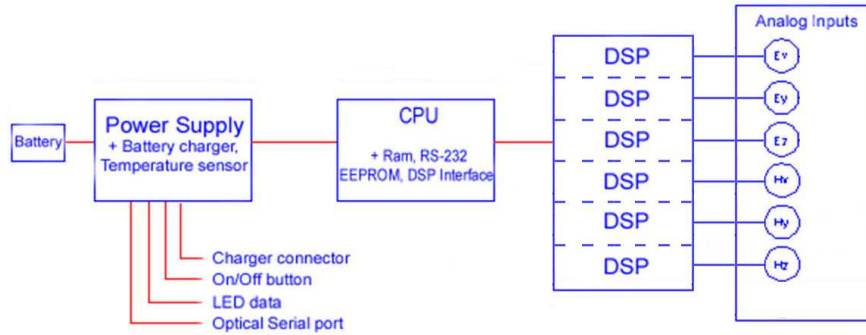
Spectral analysis, obtained through DSP (Digital Signal Processor), is performed on eight different frequency Span values and displayed on the PC monitor or NBM-550 .

Marker function is available to provide accurate field strength and frequency measurement.

EHP-50F is managed internally with a microprocessor that controls all the main functions, from the battery charging to the serial communication with the DSP unit.

Electric or Magnetic field is picked up by three sensors on the X, Y and Z orthogonal axes. A Digital/Analog conversion follows which transforms the signal into numeric information processed by a Digital Signal Processing unit.

EHP-50F is housed in a small cubic housing. The bottom side panel includes an optical fiber connector, extension rod screw, battery charger connector, ON/OFF button and Status LED.



**Fig. 1-1** Block diagram of the EHP-50F Analyzer

The magnetic sensor system is composed by three magnetic loops positioned orthogonal each other. The electric sensor system is composed by three orthogonal parallel capacitors installed on opposite side of the magnetic loops.

**1.3 Configuration and Standard Accessories**

The EHP-50F, Set for Stand-alone and PC use (P/N 2404/104), is supplied complete of the following items:

- EHP-50F Basic Unit
- AC/DC Battery Charger
- Cable, FO Duplex, RP-02, 10m;
- O/E Converter USB, RP-02/USB
- Optical Bridge Connector RP-02;
- Tripod Extension, 0.50m;
- Mini Tripod, Benchtop
- EHP50-TS software, CD-ROM including User's Manual;
- Softcase for EHP;

**1.4 Optional Accessories**

The following accessories may be ordered as options:

- TR-02A wooden tripod 1-2m with soft carrying bag;
- TT-01 telescopic mast (120-420 cm) with carrying bag;
- 8053-CC Rigid case;
- 8053-CA Car Adapter.

## 1.5 EHP-50F Main specifications

When not differently specified the following specifications are referred to operating ambient temperature 23°C and relative humidity 50%.

Table 1-1 Technical specifications of the EHP-50F Electric and Magnetic Field Analyzer				
		Electric Field	Magnetic Field	AUX input (MMCX Zin 1kΩ)
Frequency range		1 Hz ÷ 400 kHz		
Measurement range (1)	low range	5 mV/m ÷ 1 kV/m	0.3 nT ÷ 100 μT	30 nV ÷ 10 mV
	high range	500mV/m ÷ 100 kV/m (146 dB)	30 nT ÷ 10 mT (150 dB)	3 μV ÷ 1 V (150 dB)
Overload (high range)		200 kV/m (≤ 3 kHz)	20 mT (at 50 Hz)	2V
Dynamic range		106 dB	110 dB	110 dB
Resolution (2)		0.1 mV/m 1 mV/m Stand alone	0.1 nT 1 nT Stand alone	0.1 nV
Displayed average noise level (3)				
Isotropic result		5 mV/m	0.3 nT	
Single axis		3 mV/m	0.2 nT	30 nV
Flatness (@ 100 V/m, 3 μT, 1mV) (5 Hz ÷ 40 Hz) (40 Hz ÷ 300 kHz) (300 kHz ÷ 400 kHz)		±0.35 dB ±0.35 dB ±0.35 dB	±0.50 dB ±0.35 dB ±0.50 dB	±0.35 dB ±0.35 dB ±0.35 dB
Anisotropy (typ)		0.54 dB	0.12 dB	---
Linearity (referred to 100 V/m and 3 μT)		0.2 dB (1 V/m ÷ 1 kV/m)	0.2 dB (200 nT ÷ 10 mT)	0.2 dB (10 μV ÷ 1 V)
Internal memory		Up to 24 hours regardless the logging rate		
Internal data logger		1 measurement every 30 or 60 seconds		
Spectrum analysis method		FFT		
Time domain analysis method (4)		ICNIRP 1998, 2010 and 2013/35/EU weighed peak analysis		
Acquisition method		Simultaneous three axis acquisition		
SPAN		100 Hz, 200 Hz, 500 Hz, 1 kHz, 2 kHz, 10 kHz, 100 kHz, 400 kHz (500Hz to 400kHz in Stand Alone mode)		
Start frequency		1 Hz with SPAN 100 Hz; 1.2 % of the SPAN with wider SPAN		
Stop frequency		Equal to the SPAN		
Immunity to E fields		---	< 0.2 uT @ 20 kV/m	---
Immunity to H fields		< 10 V/m @ 1 mT	---	---
Calibration (5)		internal E <sup>2</sup> PROM		
Typical temperature deviation @ 55 Hz referred to 23°C (@ 50% of relative humidity when applicable)		-4x10 <sup>-3</sup> dB/°C within -20 +55 °C	-8x10 <sup>-3</sup> dB/°C within -20 +23 °C +13x10 <sup>-3</sup> dB/°C within +23 +55 °C	---
Typical relative humidity deviation @ 55 Hz referred to 50% (@ 23 °C)		+11x10 <sup>-3</sup> dB/% within 10 50 % +22x10 <sup>-3</sup> dB/% within 50 90 %	-7x10 <sup>-3</sup> dB/% within 10 50 % +10x10 <sup>-3</sup> dB/% within 50 90 %	---
Dimensions		92 x 92 x 109 mm		
Weight		550 g		
Tripod support		Threaded insert ¼"		
Environmental protection		IP42		
Internal battery		3.7 V / 5.4 Ah Li-Ion, rechargeable		
Operating time		>9 hours in standard mode 24 hours in stand alone mode		
Recharging time		< 6 hours		
External supply		10 ÷ 15 VDC, I = approx. 500 mA		
Optical fiber connection		Serial Optical Interface 38400 Baud - RP02 connector up to 40 m (USB-OC)		
Firmware updating		through the optical link by USB or RS232		
Self test		automatic at power on		
Operating temperature		-20 to +55 °C		
Operating relative humidity (6)		0 to 95 %		
Charging temperature		0 to +40°C		
Storage temperature		-30 to +75°C		

(1) For each single axis. Ranges to be selected manually

(2) For the lower measurement range

(3) DANL is frequency and SPAN depending. The specified best performance is referred to f ≥ 50 Hz and SPAN ≤ 1 kHz

(4) The FPGA operates in the time domain, implementing the hardware filters exactly as if the analog signal were passing through a chain of RC filters, being able to reconfigure poles and zeroes to adapt to legislations.

(5) Recommended re-calibration interval 24 month

(6) Without condensation

Specification are subject to change without notice

**1.6 Isotropic E&H field analyzer EHP-50F uncertainty and anisotropy**

The uncertainties have been determined according to EA-4/2 [4] and are expressed as relative values. They were estimated as expanded uncertainty obtained multiplying the standard by the coverage factor  $k=1.96$ , corresponding to a confidence level of about 95%.

**1.6.1 Measurements Uncertainty of EHP-50F (Spectrum mode)**

The total uncertainty derived from contributions of linearity, anisotropy, frequency response, temperature, relative humidity and with/without contribution of uncertainty of calibration.

Magnetic probe <sup>(1)</sup>	Magnetic flux density range	Total expanded uncertainty (k=1.96)	
		Without contribution of uncertainty of calibration $U_{T\ EHP50F}$ (%)	With contribution of uncertainty of calibration $U_{TOT}$ (%)
Frequency at 50/60 Hz	50 nT to < 100 $\mu$ T	2.4	3.1 <sup>(2)</sup>
	100 $\mu$ T to 3000 $\mu$ T	2.6	4.3 <sup>(4)</sup>
Frequency from 5 to 40 Hz	50 nT to 10.0 $\mu$ T	5.2	5.9 <sup>(3)</sup>
Frequency from 40 Hz to 100 kHz	50 nT to 10.0 $\mu$ T	4.8	5.6 <sup>(3)</sup>
Frequency from 100 to 400 kHz	50 nT to 10.0 $\mu$ T	7.5	8.1 <sup>(3)</sup>

- (1) This uncertainty budget is for an ambient temperature of (23 +/- 4) °C, and relative humidity of (50 +/- 5) %  
The expanded uncertainty for magnetic flux density for values close to 50 nT is calculated with negligible contribution of noise level.
- (2) The expanded uncertainty of calibration  $U_{Cal}$  used is 2,0%
- (3) The expanded uncertainty of calibration  $U_{Cal}$  used is 3.0%
- (4) The expanded uncertainty of calibration  $U_{Cal}$  used is 3.5%

Electric probe <sup>(5)</sup>	Electric field range	Total expanded uncertainty (k=1.96)	
		Without contribution of uncertainty of calibration $U_{T\ EHP50F}$ (%)	With contribution of uncertainty of calibration $U_{TOT}$ (%)
Frequency at 50/60 Hz	1 V/m to 1000 V/m	6.9	7.5 <sup>(6)</sup>
	1 V/m to < 40 kV/m	7.6	8.1 <sup>(6)</sup>
Frequency from 5 Hz to 100 kHz	1 V/m to < 1000 V/m	8.8	10.3 <sup>(7)</sup>
Frequency from 100 to 400 kHz	1 V/m to < 1000 V/m	9.4	10.8 <sup>(7)</sup>

- (5) This uncertainty budget is for an ambient temperature of (23 +/- 4) °C, and relative humidity of (50 +/- 5) %
- (6) The expanded uncertainty of calibration  $U_{Cal}$  used is 3.0%
- (7) The expanded uncertainty of calibration  $U_{Cal}$  used is 5.5%

**1.6.2 Explication Notes**

- a) If we have the certificate with different values of the uncertainty of calibration, in order to calculate the total expanded uncertainty  $U_{TOT}$ , the uncertainty of calibration has to be taken into account:

$$U_{TOT} = 1.96 \cdot \sqrt{(u_{T\ EHP\ 50\ F})^2 + (u_{Cal})^2}$$

where  $u_{T\ EHP\ 50\ F}$  is the standard uncertainty

$$(u_{T\ EHP\ 50\ F} = U_{T\ EHP\ 50\ F} / 1.96)$$

$u_{Cal}$  is the standard uncertainty

$$(u_{Cal} = U_{Cal} / k)$$

where  $U_{Cal}$  is the expanded uncertainty reported on certificate and  $k$  is the coverage factor reported on certificate (normally  $k=2$  or  $1.96$ )

This quadratic sum is considered a precaution because the uncertainty  $u_{Cal}$  is added quadratically to an uncertainty that is already a combined uncertainty.

- b) When the environmental temperature is higher than 23 °C, the contribute due to the temperature can be added quadratically to the uncertainty.

Example: for magnetic measurements, if the temperature is 43°C, we get a variation of 20°C in comparison to 23°C, corresponding to a variation of 0.26 dB ( 0.013 dB / °C ) equivalent to 3,04% and therefore, assuming a rectangular distribution of probability, the standard uncertainty is 1.755% ( = 0,0304 /  $\sqrt{3}$  ).

Assuming an expanded uncertainty  $U_{TOT} = 2.4\%$ ,

$$U'_{TOT} = 1.96 \cdot \sqrt{\left(\frac{0.024}{2}\right)^2 + (0.01755)^2} \cong 0.042 \text{ is obtained.}$$

The quadratic sum is considered a precaution because the uncertainty due to temperature, is added quadratically to an uncertainty that is already a combined uncertainty.

A similar calculation can be made in case the relative humidity overcomes 50%.

**1.6.3 Measurements  
 Uncertainty of EHP-50F  
 (Weighted Peak mode)**

The total uncertainty derived from typical contributions of linearity, anisotropy, the worst case deviation from the nominal weighting filter, temperature and relative humidity.

<b>Magnetic probe</b>	Total expanded uncertainty %
Frequency from 15 Hz to 100 kHz	4.6
Frequency from 10 Hz to 300 kHz	7.1
Frequency from 3 Hz to 300 kHz	8.6

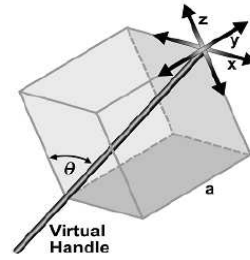
<b>Electric probe<sup>1)</sup></b>	Total expanded uncertainty %
Frequency from 15 Hz to 250 kHz	8.3
Frequency from 3 Hz to 300 kHz	9.7

Note: below 3 Hz and above 300 kHz the uncertainty increases to 0.85 dB (band limiting filter not considered).

**1.7 Anisotropy**

1) The IEEE 1309 [3] defined the anisotropy (A) as the maximum deviation from the geometric mean of the maximum response and minimum response when the probe is rotated around the ortho-axis (e.g. "virtual handle") as shown in the example in figure below.

$$A = 20 \cdot \log_{10} \left( \frac{S_{\max}}{\sqrt{S_{\max} \cdot S_{\min}}} \right) \text{ dB} \quad \text{equation (1)}$$



$$\theta = \sin^{-1} \left( \frac{\sqrt{2}a}{\sqrt{3}a} \right) = 54.7^\circ$$

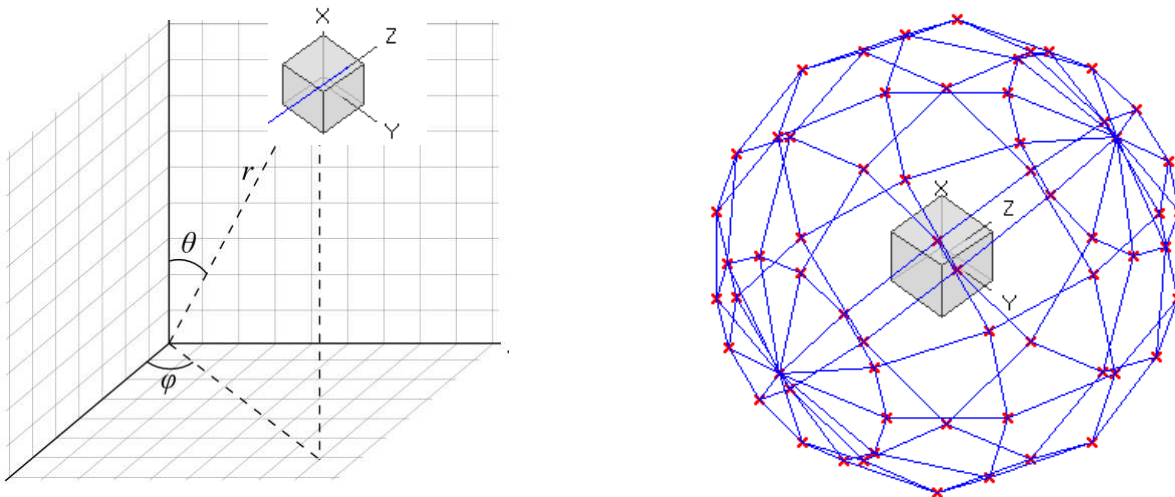
where S is the measured amplitude in field strength units.

2) The IEC 61786 [2] "Measurement of low-frequency magnetic and electric fields with regards to exposure of human beings - special requirements for instruments and guidance for measurements" doesn't define the anisotropy and suggests, for three-axis probes, the calibration of each axis when each element is aligned with the incident field.

The calibration should also be checked for a specific orientation where approximately there is the same indication for each one of the three axis (XYZ measurement).

Following this suggestion some laboratories find the minimum and the maximum values of the X,Y,Z and XYZ measure and calculate the anisotropy using equation (1).

3) We calculated the anisotropy with equation (1) but with 3D mesh measurements to cover  $4\pi$  steradians, that is to say in a much more severe condition than the orthotropic one.



**Fig. 1-2** 3D mesh measurements of magnetic probe

Each x marker in the fig.1 indicates the coordinates surface of the spherical coordinates  $(r, \theta, \varphi)$ .

The anisotropy is evaluated with 30 degrees steps for  $\theta$  and  $\varphi$ , and  $r$  shows the calibration factor at each position.

The typical value of anisotropy is 1,4% (0.12 dB) for magnetic probe and 6,5% (0,54 dB) for electric probe.

The anisotropy calculated in this way is worse respect to other cases above described and it is more representative of the reality.

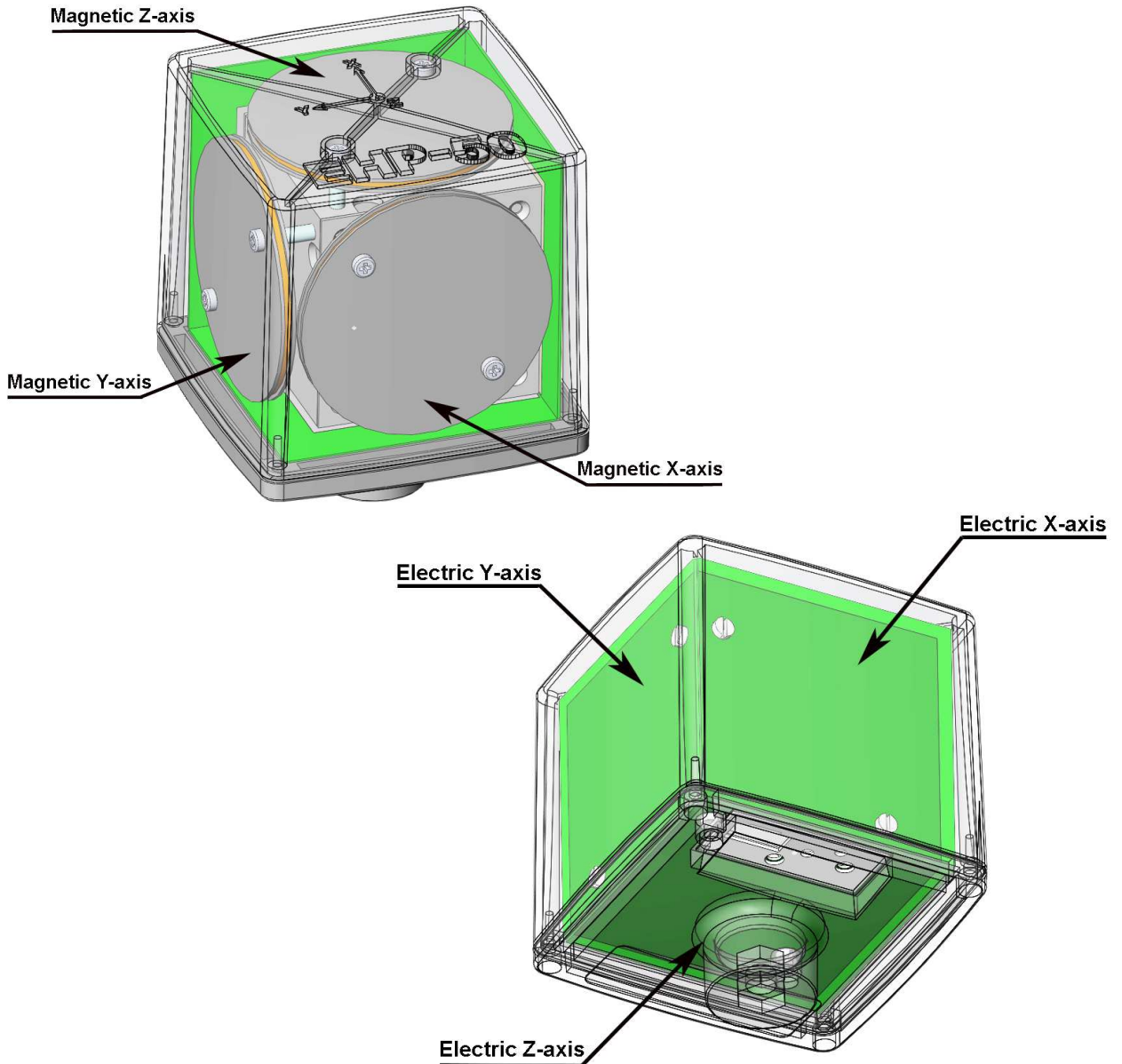


A good evaluation of the anisotropy of a field probe should be carried out in a place where all of the following conditions are satisfied:

- Far Field
- Plane wave
- Uniform field

Since the calibration systems are not infinite, these conditions can be approximated but never reached, and so the evaluation of anisotropy for our probes shows results worse than the reality. So, the real typical anisotropy response is better than what specified.

EHP-50F is housed in a small cubic case. The bottom side panel includes an optical fiber connector, extension rod screw, battery charger connector, ON/OFF button and Status LED.

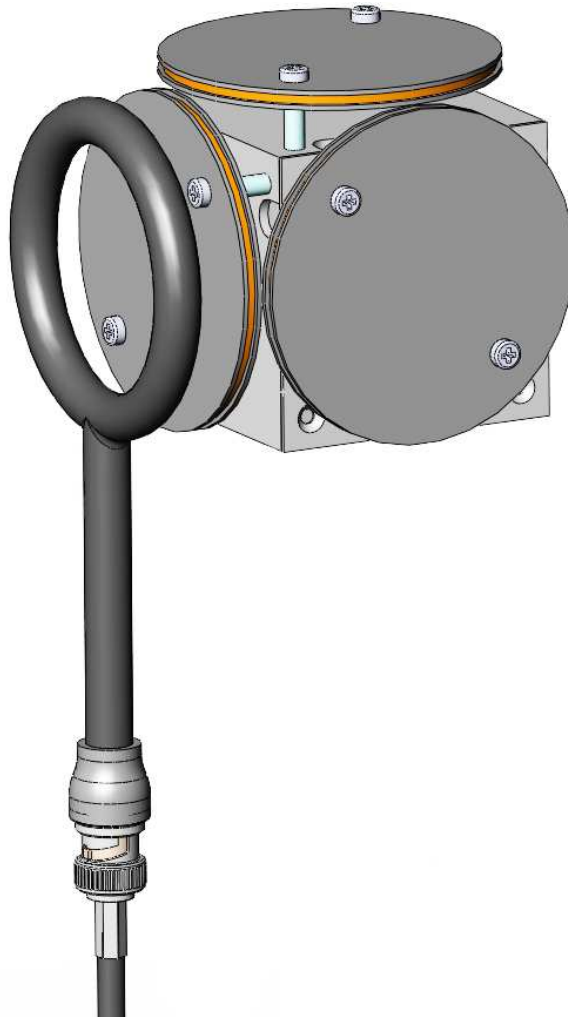


**Fig. 1-3 EHP-50F axes**

The sensitive elements are located approximately 9 mm below the external surface

As depicted above, the magnetic sensor system is composed by three magnetic loops positioned orthogonal each other. The electric sensor system is composed by three orthogonal parallel plates capacitors installed on the opposite side of the magnetic loops.

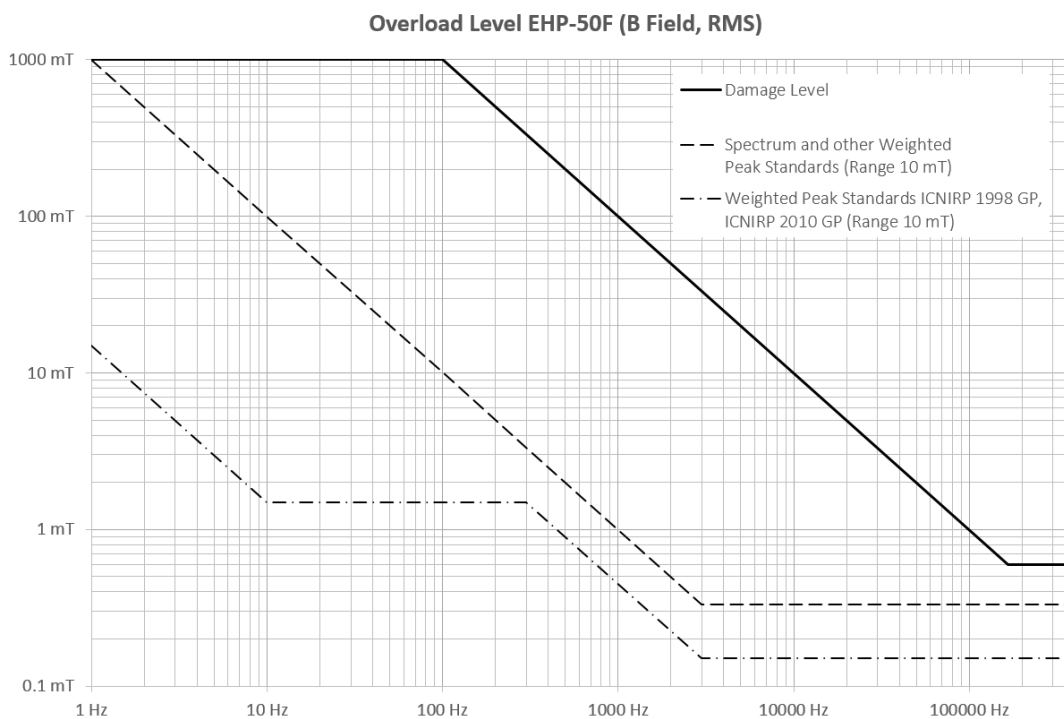
The geometric structure of the Narda probes, with sensors placed on the peripheral faces of the cube, shows the same behavior as one with the sensors accumulated in the center, when measuring far fields. Moreover, this provides the opportunity to evaluate also very nearby fields, albeit with all the limitations that this entails, knowing exactly where the single sensor is, and allowing to minimize the contribution of the others.



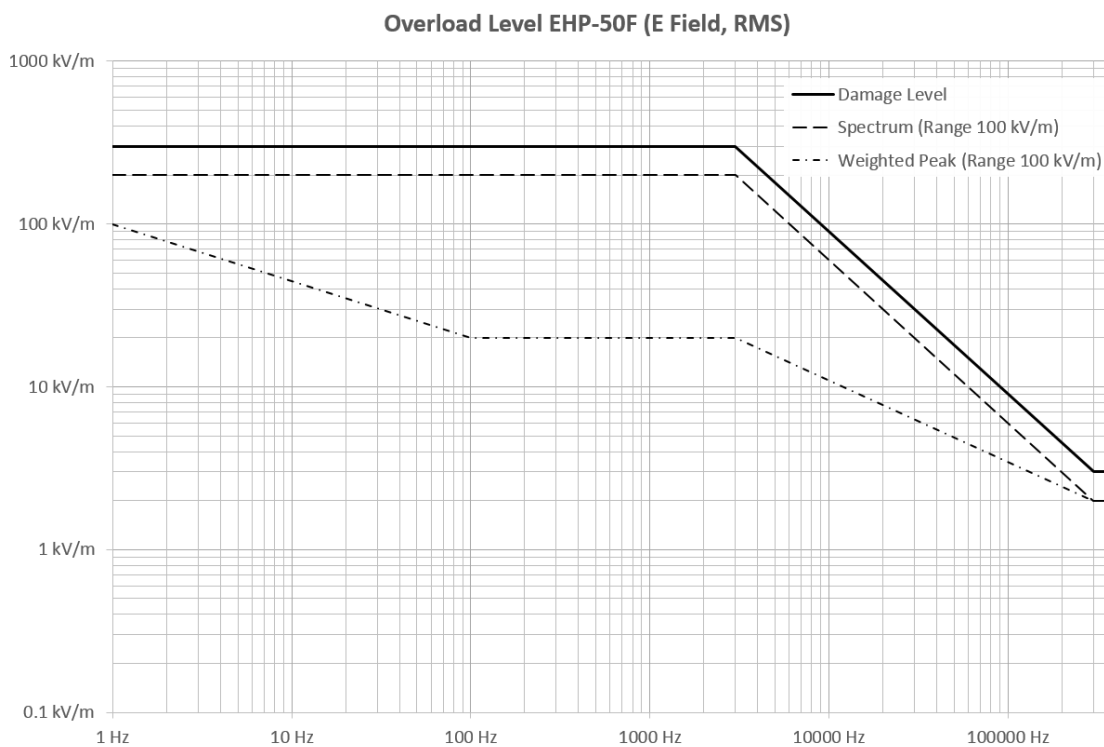
## References

- [1] ISO/IEC “Guide to the expression of uncertainty in measurement” JCGM 100:2008 GUM 1995 with minor correction – International Organization for Standardization.
- [2] CEI-IEC 61786-1 ed. 1.0 “Measurement of DC magnetic, AC magnetic and AC electric fields from 1 Hz to 100 kHz with regard to exposure of human beings – Part 1: Requirements for measuring instruments.
- [3] IEEE Std 1309™-2005 (revision of IEEE Std 1309-1996) “IEEE Standard for Calibration of Electromagnetic Field Sensors and probes, Excluding Antennas, from 9 kHz to 40 GHz”.
- [4] EA European co-operation for Accreditation – Public Reference EA-4/02 M:2013

### 1.8 Overload level



**Fig. 1-4** Overload level EHP-50F (B Field, RMS)



**Fig. 1-5** Overload level EHP-50F (E Field, RMS)

### 1.9 EHP-50F Panel

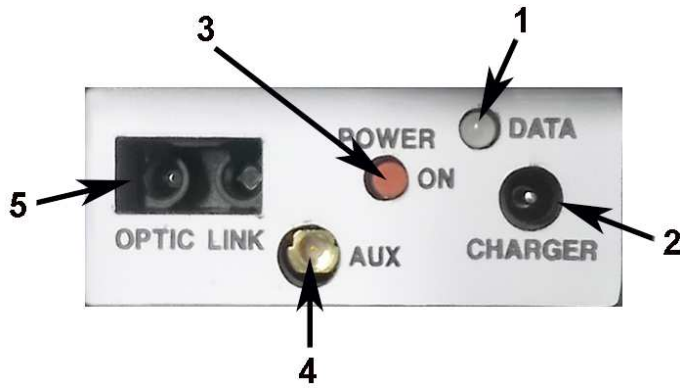


Fig. 1-6 Panel of EHP-50F

**Key:**

- 1. Led
- 2. Battery charger connector
- 3. ON/OFF button
- 4. AUX input connector MMCX male type
- 5. Fiber optic connector

## 2 - Installation and use

### 2.1 Introduction

This section provides the information required for installing and using the EHP-50F Analyzer.

Information is included regarding initial inspection, power requirements, interconnections, work environment, assembly, cleaning, storage and shipment.

### 2.2 Preliminary inspection



**WARNING**

Inspect the packaging for any damage.

**If the packaging or anti-shock material have been damaged, check that the contents are complete and that the meter has not suffered electric or mechanical damage.**

**Check that all the Accessories are there against the checklist found with the apparatus.**

**Inform the carrier and NARDA of any damage that has occurred.**

### 2.3 Work environment

The work environment of the Accessories, must come within the following conditions:

- Temperature From -20°C to +55°C
- Humidity 0 to 95% relative

The meter must be stored in a clean and dry environment, free from acid dusts and humidity.

The storage environment must come within the range of the following conditions:

- Temperature From -30°C to + 75°C
- Humidity < 100% relative without condense

### 2.4 To return for repair

When the meter needs to be returned to NARDA for repair, please complete the questionnaire appended to this User's Manual, filling in all the data that will be useful for the service you have requested.

For reducing the period of time required for the repairs, it is necessary to be as specific as possible in describing the problem. If the problem only occurs in certain circumstances, please describe in detail how it happens.

If possible it is better to reuse the original packaging; making sure that the apparatus is wrapped in thick paper or plastic.

Otherwise, use strong packaging by using a sufficient quantity of shock absorbent material around all sides of the meter to ensure that it is compact and does not move around inside the package.

In particular, take every precaution to protect the front panels.

Finish the package by sealing it up tightly.

Apply a FRAGILE label to the package to encourage greater care in its handling.



**NOTE**

Nowadays there are restrictions on the shipment of hazardous materials, eg. some types of lithium batteries.

Please, check the proper, safe, shipping mode, with the help of your courier, in the case the product is equipped with batteries.

### 2.5 To clean the meter



**WARNING**

Use a dry, clean and non-abrasive cloth for cleaning the meter.

**Do not use solvents, acids, turpentine, acetone or other similar products for cleaning the meter in order to avoid damaging it.**

**2.6 Power supply and battery recharging**

EHP-50F has an internal rechargeable Li-Ion battery that can be recharged with the battery charger supplied with it.

Make a full charging cycle before using the Analyzer for longest battery operation time.

**ALWAYS connect the battery charger to the power supply BEFORE connecting it to the EHP-50F.**



The battery charger has an internal protective circuit that will limit the output of current if there is any load when connecting to the mains. Always remove the shorting loop connector when recharging EHP-50F.

Battery charger:  
output: DC, 10 - 15 V, ~ 500 mA



Connector:



In order to safeguard the features of the batteries, it is crucial to have a complete recharge before storing them for periods longer than 4 months. Therefore, it is warmly suggested recharging the batteries at least every 4 months even though the device has not been used.



The minimum voltage level for operation is about 3.25V. The batteries must be recharged for lower voltages. Below such voltage the analyzer will turn OFF automatically.

The time required for recharging the batteries is about 4-5 hours. When the recharge is complete, this is indicated by the Led of the EHP-50F, with a rapidly blinking Green light.



To take measurements **ALWAYS** remove the battery charger from the EHP-50F Analyzer otherwise the system does not work.



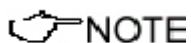
The battery status is reported by the EHP-50 control program

When charging is in progress the connection to the probe is not available.

**2.7 EHP-50F connected to a PC** Using the EHP50-TS software spectrum analysis can be displayed on a PC (see chapter 3 and 4).

**2.8 EHP-50F stand alone Mode** The EHP-50F offers a Stand-alone mode of operation and thanks to its internal memory is possible to perform a long term acquisition without connecting it to any external device.  
With EHP-50F is possible to collect data every 1 minute or every 30 seconds for 24 hours. Later on, it is possible to download all collected data to any PC by using the provided EHP50-TS PC software (see chapter 5).

**2.9 EHP-50F with NBM-550** EHP-50F is linked to NBM-550 via the fiber optic link.



**See NBM-550 Manual for further details**

**2.10 Battery management** The Table summaries the battery autonomy of the Analyzer depending on its mode of operation.

<b>TABLE 2-1 Autonomy of the battery</b>			
		<b>STAND ALONE MODE</b>	
<b>Span</b>	<b>Normal functioning Autonomy (hours)</b>	<b>30s Sample</b>	<b>60s Sample</b>
100 Hz	>10	---	---
200 Hz	>10	---	---
500 Hz	>9	>24	>24
1 kHz	>9	>24	>24
2 kHz	>8	>24	>24
10 kHz	>8	>24	>24
100 kHz	>8	>24	>24
400 kHz	>8	>24	>24

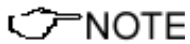
## 2.11 Avoiding measurement errors

To avoid disturbing the measurements in progress, the user or other persons or mobile vehicles should stay at least 5 meters away from the Analyzers. We also recommend that the probe be set up a long way from metal objects or masses.



To perform correct measurements, the tripod TR-02A to hold EHP-50F is mandatory. Using an unsuitable support could influence the measurements that have been taken and, therefore, determine incorrect results. We recommend always using the isolated extension support supplied with EHP-50F for supporting the Analyzer.

We also recommend that the TR-02A optional tripod be used for positioning EHP-50F at the height set out in the reference standards for the measurement in progress and that this configuration is always maintained so that the measurements taken can be repeated.



The intensity of the measured field mainly depends on its voltage and the geometry of the system under examination as well as the distance between the conductors and the measurement points. In the vicinity of cables, the reading of the field value may be very high and vary with the location of the probe.

From the definition of the potential difference between two points:

$$V_{21} = - \int_{r_1}^{r_2} \vec{E} \cdot d\vec{r}$$

It is evident that, keeping the potential difference constant as the distance between the two points under examination decreases, the intensity of the field necessarily increases.

For example: the intensity of the electric field between two armatures of a parallel-plate capacitor situated at a distance of 0.1 m and having a potential difference of 100 V is equal to:

$$E = \frac{100V}{0,1m} = 1KV/m$$

It should be noted that a voltage of 100 V, in these conditions, generates a field of 1000 V/m. It is, therefore, possible, in the vicinity of 220 V conductors, that there may be a field, which is much higher than 220 V/m.



## 3 – EHP50-TS installation

### 3.1 Introduction

EHP50-TS is a useful software tool developed for remote PC control, through fiber optic link, of EHP family Electromagnetic field analyzers.

By means of the recently introduced USB-OC optical to USB converter, EHP-50F can be connected to a PC USB port.

Using the former optical/RS232 adapter, the selected COM port should be assigned to the application software (see cap.5 EHP50-TS applications).

EHP50-TS software requires that at least one of the mentioned analyzers is connected to PC in order to run.

The EHP50-TS installation program automatically installs the driver for USB optical converter.

### 3.2 Hardware requirements

Minimum requirements:

- Processor: Pentium or equivalent
- 256 MB RAM
- At least 64 MB of free space on hard disk
- 1 free USB or RS232 port
- Windows Operating system™ XP/Vista/Win7/Win8/Win8.1/Win10



**WARNING**

**The User might have the need of administrator privileges to install and run the software in Windows Vista, Win7, Win8, Win8.1 and Win10; for further information see the next paragraph.**



**WARNING**

**EHP50-TS software does not work with EHP50A/B.**



**WARNING**

**The EHP-50F requires an EHP50-TS software version 1.61, included in the EHP-TS software setup version 1.64 or later.**

**The new releases can be downloaded directly from the narda website. <http://www.narda-sts.it>**

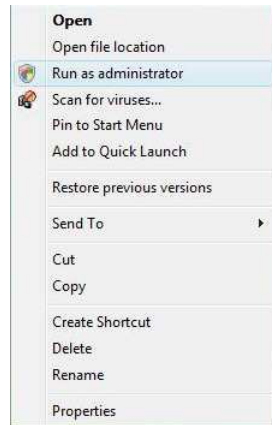
### 3.3 Installing EHP50-TS Software

Before connecting the EM field analyzer to PC the EHP50-TS software installation should be performed: Insert the EHP50-TS CD into the driver of your PC and run the file “EHP-50 Setup.exe”.



**NOTE**

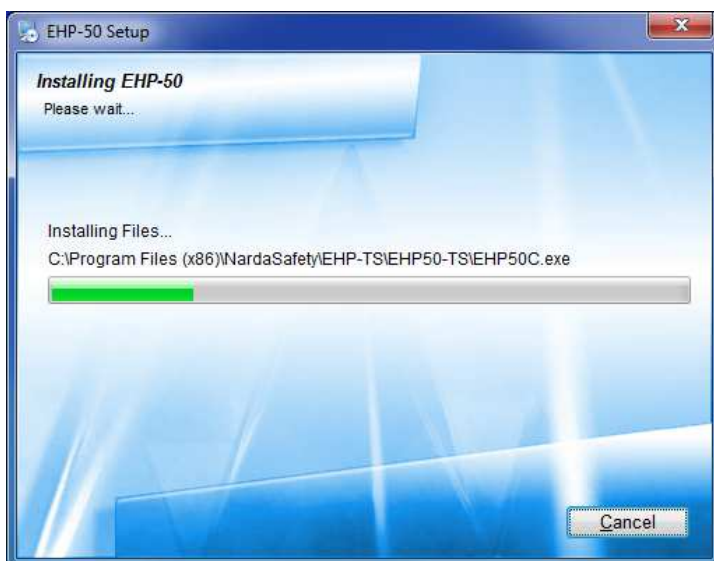
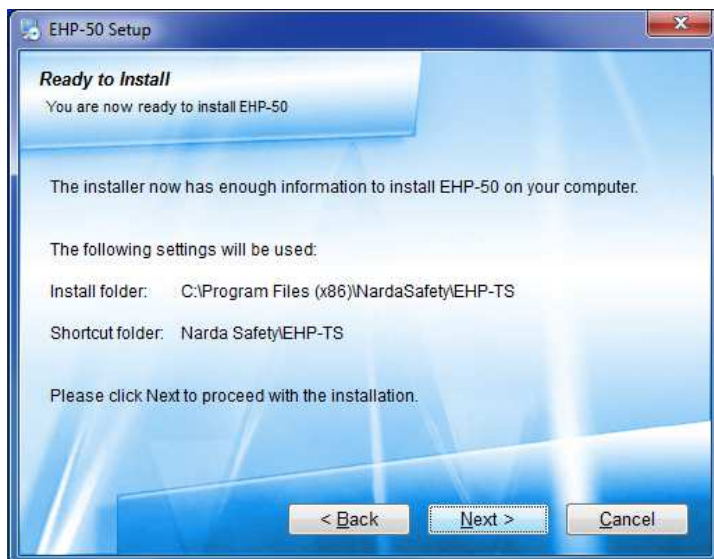
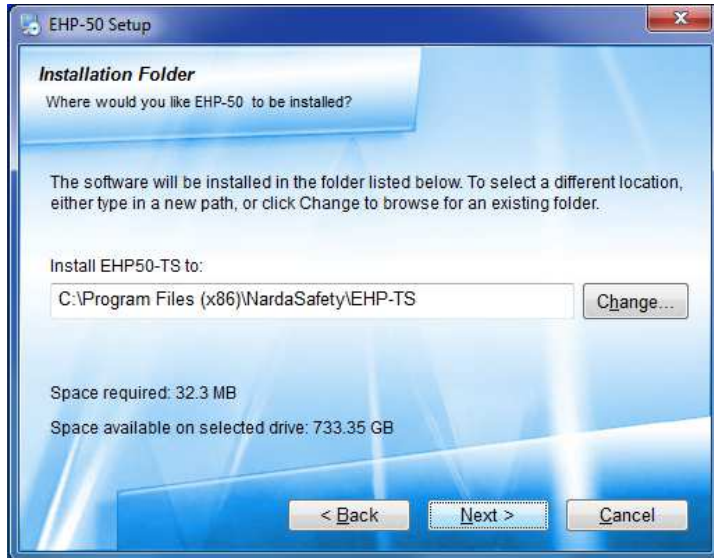
The User must have administrator privileges to install the EHP-TS software in Windows Vista, Win7, Win8, Win8.1 and Win10; right click on the program .exe file and click on “Run as administrator” to temporarily run the program or application as an administrator until close it (Win7, Win8, Win8.1 and Win10 also allows to mark an application so that it always runs with administrator rights).

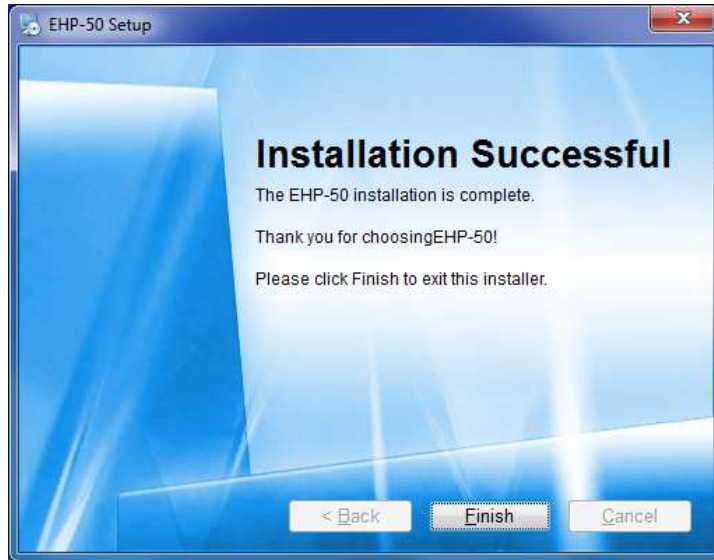


Follow set-up program instructions



Fig.3-1 EHP50-TS installation





When asked for, reboot your system to complete installation

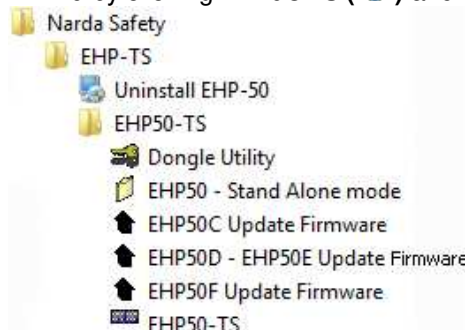


EHP50-TS software is now installed in your PC, you can remove it, if needed, simply running the "Uninstall EHP50-TS" application (see cap.8).

## 4 – EHP50-TS software

### 4.1 EHP50-TS Applications

EHP50-TS software includes different applications to be used with EHP family analyzers. Shortcuts are shown, selecting “all programs” from the windows XP “start” button or, using Windows Vista, Win7, Win8, Win8.1 and Win10 by clicking **Windows** (🌐) and **Programs**:



The EHP50-TS section includes three different applications:

**Dongle Utility:** allows to enable the function ordered such Options using the **40 Digit Activation Code** received from NARDA Italy.


**EHP50 – Stand Alone Mode:** main task of this program is to set up EHP-50F for standalone mode. The analyzer will take and log E or H field measurements (according to the setting) for up to 24 hours, when switched on without any connection to external devices (see operating manual for details). Using EHP-50-Stand Alone mode program is then possible to download measurement results and store them as a text file.

**EHP-50C Update Firmware:** this is a tool to update EHP-50C firmware.

**EHP-50D – EHP50E Update Firmware:** this is a tool to update the firmware and FPGA of the EHP-50D and EHP-50E.

**EHP-50F Update Firmware:** this is a tool to update the firmware and FPGA of the EHP-50F.


**EHP50-TS:** this program is used to perform live Time Domain and Spectrum Analysis measurements when an EHP-50F analyzer is connected to PC

 NOTE


**The User might have the need of administrator privileges to install and run the software in Windows 7, Win8, Win8.1 and Win10; for further information see the paragraphs in Chapter 3.**

 WARNING

**EHP50-TS software does not work with EHP50A/B.**

 NOTE

**If the battery charger is plugged in to the EHP-50F while the software is running, the analyzer will be disconnected.**

 NOTE

**During the charging process, always remove the bridge (stand-alone) connector from the EHP-50F**

**4.2 EHP-50F Installation**

This chapter describes controls and functions provided by the EHP50-TS application for time domain and spectrum analysis, included in EHP-TS software package.

To install EHP-50F, connect the supplied fiber optic to the **OPTIC LINK** connector taking care that the spigot matches the housing. Connect the other end of the fiber optic to the **OPTIC LINK** connector of the USB-OC or 8053-OC. Connect the converter to a port of the PC.



**Do not pull the fiber optic by holding onto the cable but use the connector so that the head does not get damaged. Avoid dirt and other particles getting into the transducers of the fiber optic.**

**4.2.1 Main menu**

Turn on EHP-50F by pushing the Red **POWER** button for one second (**ORANGE** LED for about 1 second is shown on button press). After that, the led turns off for 2 seconds, lights orange for about 1/2 second as an auto-check and then blinks red.

Communication with PC is shown by the blinking **GREEN** LED.

Run EHP50-TS application; a welcome screenshot will appear for a few seconds.



**Pressing the POWER down button for more than 4 seconds forces the hardware of the apparatus to shut down. Then, it is necessary to wait several seconds before switching it on again.**



**EHP-50F must be ON before running EHP50-TS control software. EHP-50F may not be correctly recognized if switched ON when the control software is already running.**



**The fiber optic of the EHP-50F can be disconnected and reconnected while in use. In this case, communication will be restarted automatically.**

**If the stored Firmware and/or FPGA version is older than what is available, the software will inform you that an update is needed. Confirm with OK and the Firmware/FPGA updating utility will be automatically run (for further information please see chapter 7).**



**Fig.4-1 EHP50-TS Main Window**

Otherwise the program EHP50-TS main window will be shown:

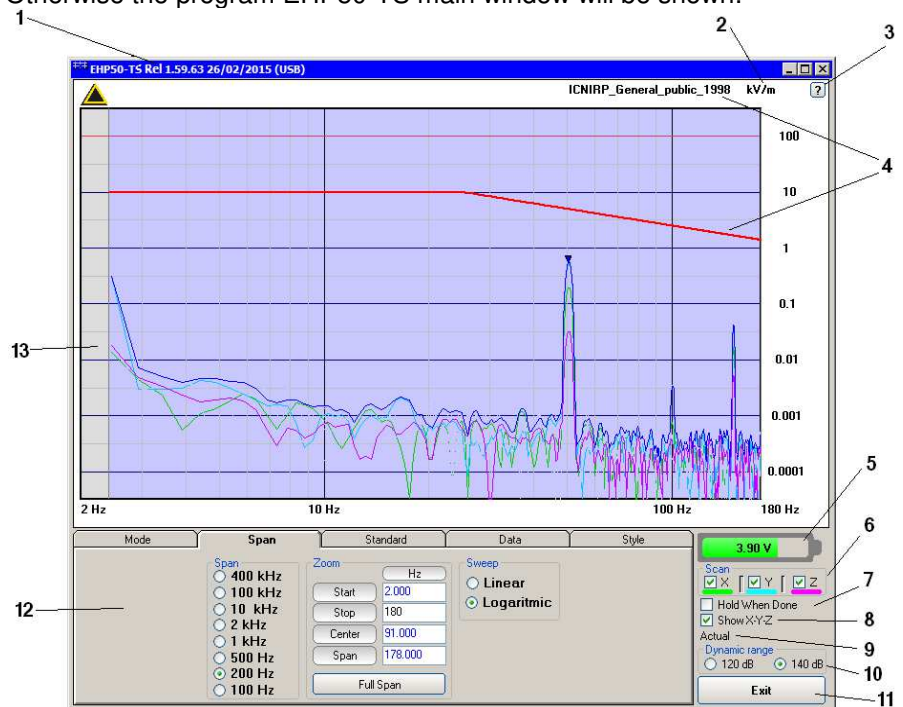


Fig.4-1 EHP50-TS Main Window

Description:

- 1 - EHP50-TS software release, (communication port)
- 2 - Shows unit
- 3 - Click “?” to display EHP-50F analyzer information
- 4 – Name and trace of selected Limit
- 5 - EHP-50F analyzer battery status
- 6 - **Scan** activation for each axis (default setting: all axis activated)
- 7 - **Hold When Done**: stops acquisition to allow data analysis as soon as all axis have been measured. Enable this function always with narrow SPAN if is necessary save TXT file. This to avoid difference between spectrum and acquired measures.
- 8 - **Show X-Y-Z**: to display or not the traces of single axis.
- 9 - Acquisition mode selected (see **Mode** section)
- 10 - **Dynamic range** (chosen between 120 and 140dB)
- 11 - **Exit** button to terminate application
- 12 - Control panel
- 13 – Display for time domain / spectrum analysis

Commands are grouped in the control panel in 5 different sections:

**Mode**: to set different operating modes

**Span**: to select a specific frequency span and, within the selected span, to set zoom function

**Standard**: to create and save limit traces, to activate a specific limit

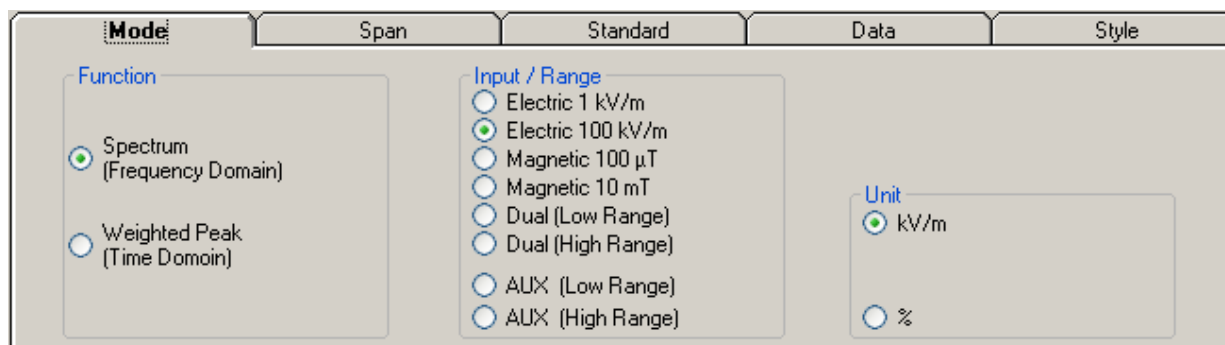
**Data**: to display measurement results and save data

**Style**: to change colour and button aspect

Each section can be activated with a mouse click.

### 4.3 Mode section

Mode section allows setting different acquisition modes, including Frequency and Time domains choice, as well as defining Electric, Magnetic field, or both in the same graph, and preferred Unit.



**Function:** measurements are displayed in different acquisition modes:

**Spectrum:** Frequency Domain sweeps are shown; display is continuously updated with new readings.

**Weighted Peak:** Time Domain shows a continue running graph over the specified period. This is a rolling peak. Once the first time period has been completed, oldest data are discarded and replaced by the newest ones, thus showing the values of the latest time period as specified.

**Input/Range:** to select electric, magnetic or dual mode field (contemporary displaying of both Electric and Magnetic fields) in two different ranges. Dual (Low Range) shows Electric and Magnetic field which full range values are 1kV/m and 100μT respectively. Full scale ranges of Dual (High Range) are therefore 100kV/m and 10mT  
 The EHP-50F is also equipped with an AUX Input (MMCX connector, Zin 1 kΩ) for two different ranges. Aux (Low Range) shows fields which full scale value is 10 mV. Full scale of Aux (High Range) is therefore 1 V.

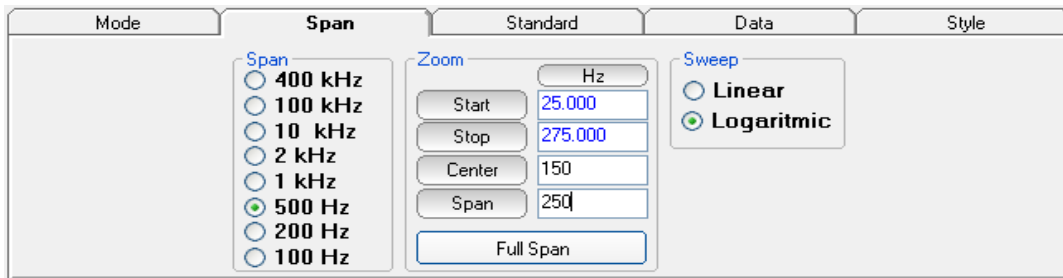
**Unit:** to select unit according to the Input setting. Electric field can be expressed in V/m and % of the limit only while Magnetic field can be expressed in A/m, μT (magnetic induction), mG or % of selected limit. Dual mode units are always V/m and A/m.

**NOTE**

**The unit “%” can be selected only if a Limit has been activated. Each spectrum line will then represent the field strength expressed as percent of the selected limit.**



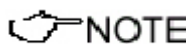
#### 4.4 Span section



EHP-50F includes an FFT analyzer to show frequency spectrum of measured field. The span section includes the following:

**Span:** select one of the 8 available **spans**, keeping in mind that beside the EHP-50F minimum operating frequency of 1 Hz, the minimum **start** frequency of each Span is 1,2% of Span. For example, selecting 1 kHz span the minimum start frequency should be 12 Hz (automatically adjusted to the nearer step available of 12.5 Hz). This to avoid that the 0Hz signal, common to every spectrum analyzer, is included in the measurement result. Start frequency of 100 Hz and 200 Hz span is therefore 1 Hz (minimum operating frequency).

**Zoom:** EHP-50F performs selective measurement over the entire frequency range defined by the Span setting. EHP50-TS is able to select data in order to display a user specified frequency band within the selected span. For this purpose, the Zoom function can be set by typing the relevant parameters through the PC keyboard or, graphically, by means of the PC mouse. Within the selected frequency **span**, you can operate a zoom function to define a specific frequency range over which perform your measurement. For this purpose **Start**, **Stop**, **Center** and **Span** can be set to easily define frequencies to be displayed. The **Full Span** button deactivate the Zoom function showing the whole Span selected.



**Right click and drag on the graph window to define graphically the Zoom frequency range.**

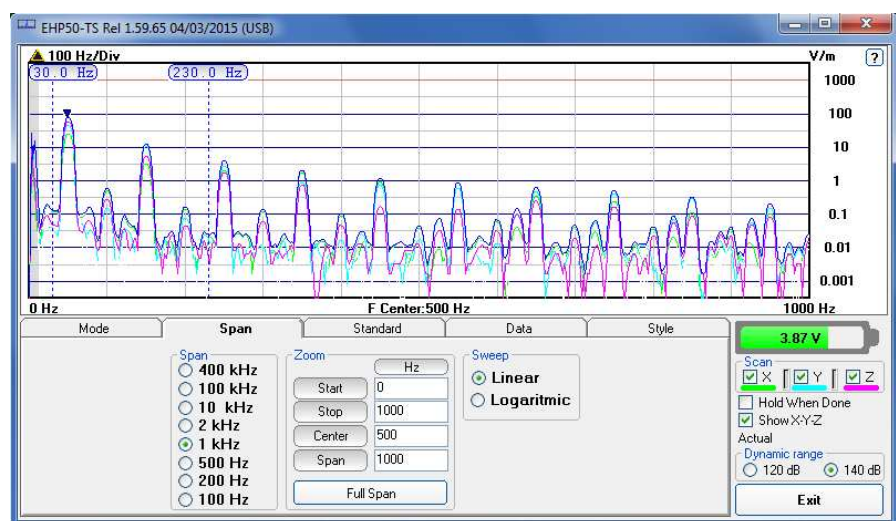


Fig.4-2 Defining frequency band through the PC mouse

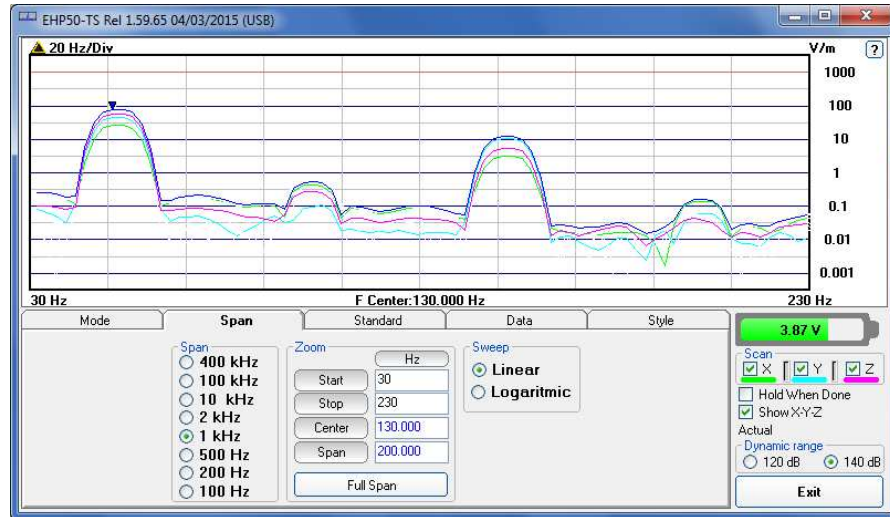


Fig.4-3 Zoom window

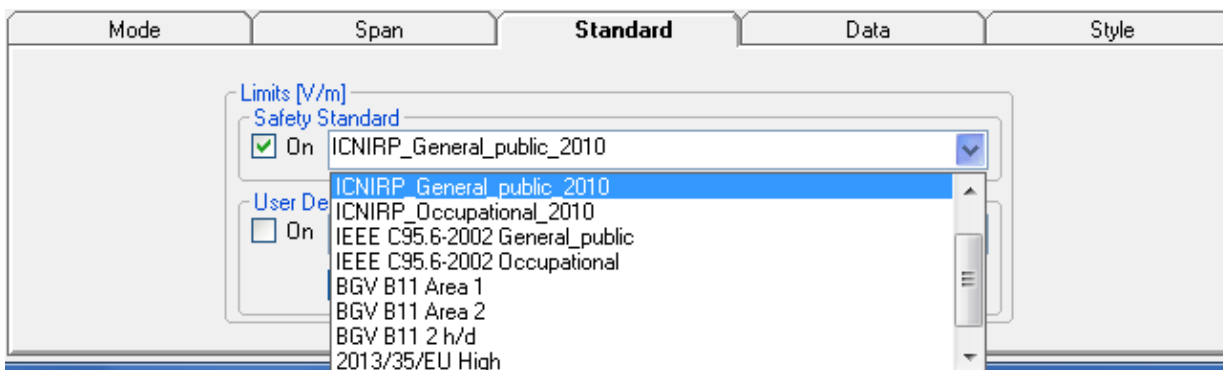
Also choosing the best scale range 120 dB or 140 dB can be helpful to better distinguish signals and disturbances.

**Sweep:** the two radio buttons in this box allow the user to select the **Linear** or **Logarithmic** frequency scale.

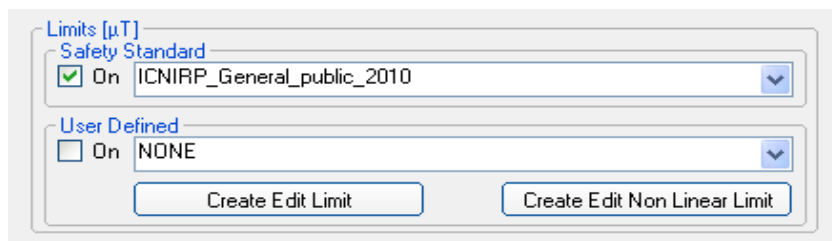
Logarithmic scale is used to emphathise and clearly display low frequencies even thow high ones are included in the graph. High frequencies are therefore compressed to the high side of displayed range.

#### 4.5 Standard

Standard section allows the user to select standard ICNIRP, IEEE, BGV and EC limits, already included by the software installation, as well as user's limits which can be created through the "Make Limit" function provided by this section.

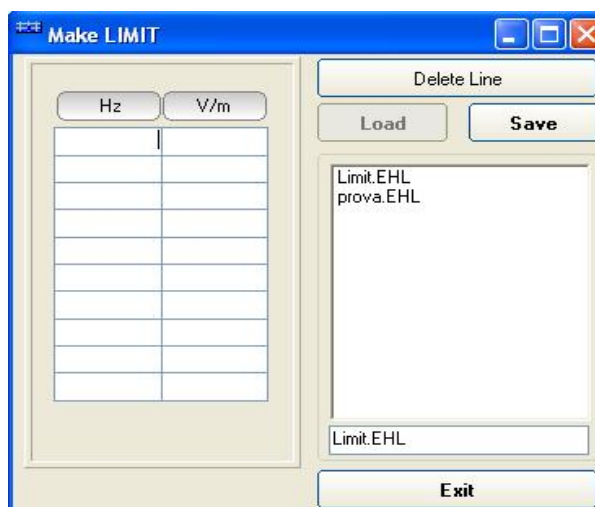


**Safety Standard:** This section can be used to load a default standard limit saved into the memory at the factory. Default limit list shows limits that are compatible to the actual setting only. If Electric field was selected in the Mode section, electric field limits only are displayed. No default limit is shown in case mG unit was selected.




**User Defined:** This section allows to select and activate a specific limit among limits created and saved by the user. They can be Linear or Non Linear (governed by a mathematic formula).

The **Edit Limit** button opens a window to edit linear limits and create new ones:

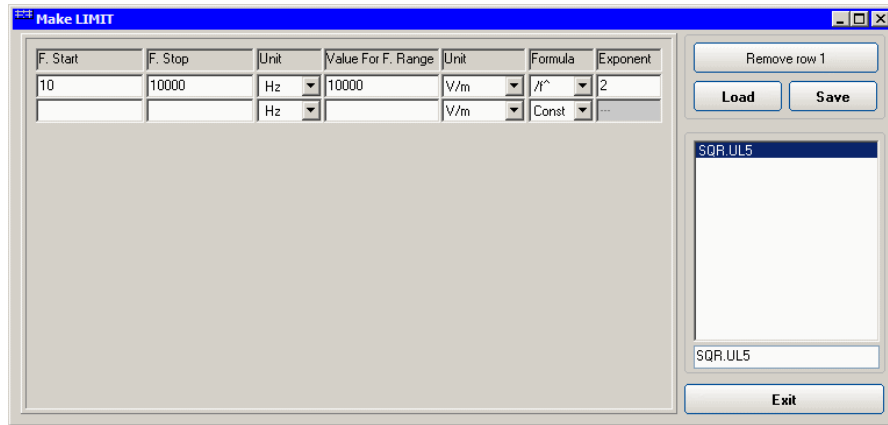


Type frequency and field strength for each point of the required limit and click save to save it under the program directory. The limit file will be created as a linear interpolation between specified points.

 **NOTE**

**When the ICNIRP or IEEE limit is selected, the software automatically calculates the corresponding total integration of the measured signals, and compares the result with the threshold set by the standard, considering whether it is or is not exceeded.**

The **Edit Non Linear Limit** button opens a window to edit those limits that are related to a mathematic formula, and create new ones:




Click Load to edit a previously saved limit.

Type in the Start and Stop frequencies in the appropriate boxes, and choose the right measurement Unit.

Introduce the strenght Value and choose its Unit.

Then choose the formula from the list and type the exponent value.

Click save to save it under the program directory. The limit file will be created as a calculation of the mathematic expression.

 **NOTE**

**The Max Hold function is not available when the ICNIRP or IEEE limit is selected.**

#### 4.6 Data section

Even if EHP-50F takes measurement over the entire selected span, shown results are related to the displayed spectrum only, allowing thus detailed evaluation of user defineable frequency range through the zoom function.

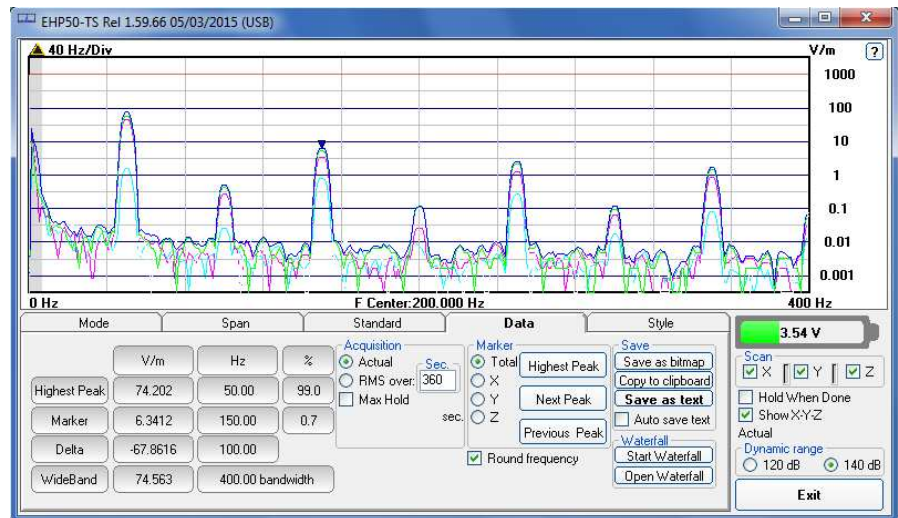


Fig.4-4 Data section

The gray band on the left side of the graph highlights signals below the minimum start frequency (1,2 % of Span) which are affected by residual 0 Hz peak. Calculation of Wideband result does not include any spectral line within the gray band.

**Measurement result:** the following values are shown in a table form:

**Highest Peak:** Maximum value within the displayed spectrum.

Shown parameters:

Highest Peak field strength in the selected Unit (V/m in the above picture)

Highest Peak frequency (Hz)

% of contribution to the WideBand result

**Marker:** you can place a marker anywhere on the spectrum display with a mouse click

Shown parameters:

Field strength at Marker frequency in the selected Unit (V/m in the above picture)

Marker frequency (Hz)

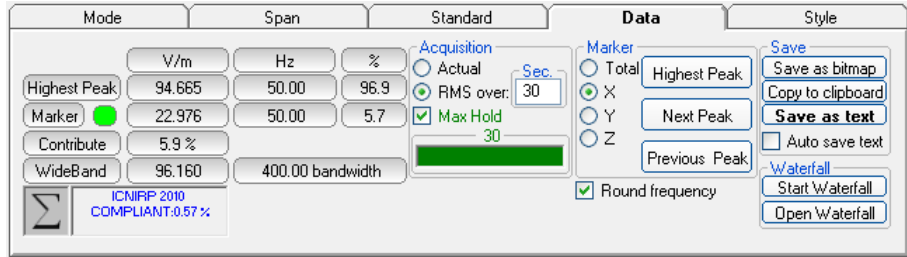
% of contribution to the WideBand result

**Delta:** Difference in Field strength and frequency (Hz) between Highest Peak and Marker

**WideBand:** integration over the displayed frequency band

It is the square sum of all contributions within the displayed spectrum. Result of calculation is the field strength expressed in the selected unit while "Bandwidth" is the difference between Stop and Start frequency.

Four additional frames, Acquisition, Marker, Save and Waterfall, are included in the Data section:



**Acquisition:** spectrum is displayed in different acquisition modes. Here is the choice between instantaneous reading and Root Mean Squared over a certain period, which is set in the proper box. A Max Hold function is also available. When the RMS is activated, a progressive bar appears showing, step by step, how many seconds are already taken into account for the calculation of the result.

**Actual:** instantaneous values are shown; the display is continuously updated with new instantaneous readings.

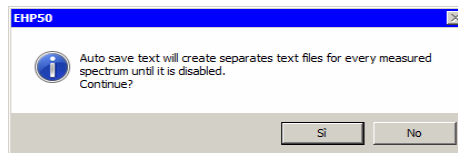
**RMS over:** square average calculated over the specified time period (sec) is shown. This is a moving average. Once the first time period has been completed, oldest data is discarded to be replaced by the newest one showing thus the average value of the latest time period as specified.

**Max Hold:** the maximum field strength value of each frequency step is retained and displayed since the Max Hold function has been activated. Every spectral line is therefore updated only if the new value is greater than the previously displayed one showing thus the Maximum of each spectral line since the Max hold function was activated.

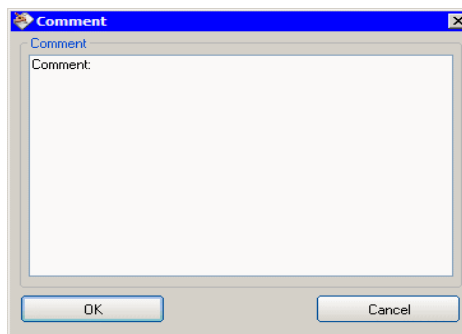
**Marker:** in this area you can select on which trace to place the Marker: specific axis (X,Y,Z) or Total result. Three dedicated buttons, Highest Peak, Next Peak and Previous Peak, allow Marker positioning over peaks shown by the graph. If activated, Limit checkbox allows displaying the Limit value corresponding to the Marker frequency.

**Save:** three buttons in this area to save spectrum as a picture file (.bmp), as a text file (.txt) or to copy the spectrum picture to the Windows Clipboard.

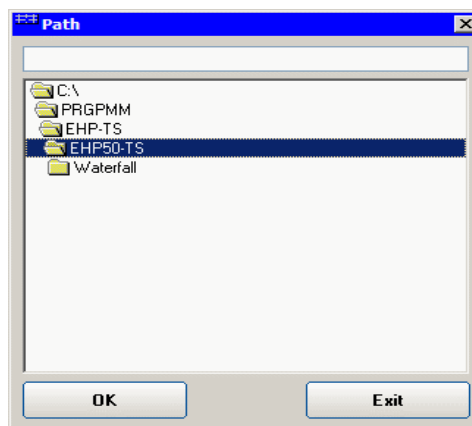
**Auto save text:** it is a functionality provided to automatically save a text file containing the measurements data and information.



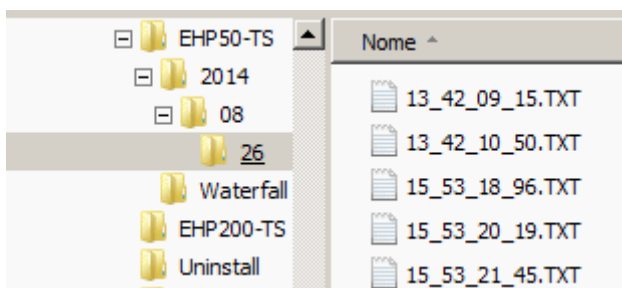
It is also possible to insert a comment.



The user can select the path where the files will be stored.



The saved files will be structured as following:



Under the selected folder (EHP50-TS in the example) a folder will be created and called like the current year (ex. 2014). Inside this folder, another one will be created and called like the current month (ex. 08, that is to say August). Again inside a folder will be created for each day of saving (ex. 26). The measurements will be in this last folder and their names will be in the format *hh\_mm\_ss\_cc.TXT*

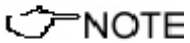
EHP50-TS Spectrum 26/08/14 13:42:09 Narda Safety Test Solutions  
 EHP50E Rel 4.20  
 Span: 2000 Hz  
 WideBand: 536.54 V/m (24 - 2002) Hz  
 Highest Peak 536.49 V/m @ 49 Hz  
 Acquisition: Actual

Freq Hz	Total V/m	X V/m	Y V/m	Z V/m
0	0.0004	0.0002	0.0002	0.0002
5	37.986	31.159	11.130	18.659
10	20.870	17.023	6.2038	10.357
15	5.8903	4.7538	1.9176	2.9017
20	0.3747	0.1965	0.2578	0.1881
24	0.2747	0.1511	0.1755	0.1478
29	4.0882	0.7086	0.2787	4.0166
34	76.889	14.076	4.4910	75.456
39	308.36	56.620	18.341	302.56
44	511.53	94.021	30.659	501.87
49	536.49	98.720	32.356	526.34
54	514.77	94.841	31.249	504.99
59	386.52	71.196	23.586	379.17
63	143.97	26.484	8.7990	141.24

### Auto save text extract example

**Round frequency:** when this label is ticked, the frequency indication of the Marker is corrected to the closest round value, thus avoiding approximation errors.

**Waterfall:** press Start Waterfall to run the function, or Open Waterfall to load previously saved measurements.



**The Max Hold function is not available when the ICNIRP or IEEE limit is selected.**



#### 4.6.1 Waterfall

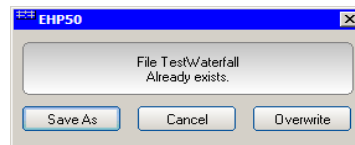
In addition to the spectrum view, another representation has been introduced in the software, commonly called Waterfall.

The advantage of this view is that the disturbances are shown in a tridimensional plot. Two dimensions are, as usual, frequency and level, and the third is the time.

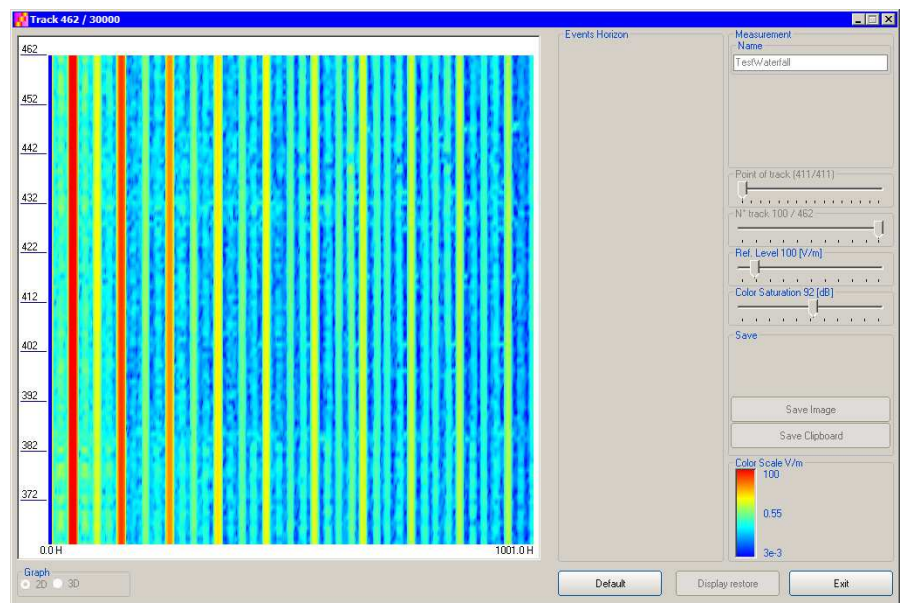
In this way it is possible to detect and track time-varying signals.

The ranges for Frequency and Level are the same as the Spectrum view.

When pressing the **Start Waterfall** button, a pop-up message can appear warning the operator if a file with the same name as the one in use, already exists.



Press **Save As** to maintain the original file, or **Overwrite** to cancel the old measurement with the starting new one.



**Fig.4-5** Waterfall - Graph 2D

In the **Graph 2D**, the horizontal axis represents Frequency, the vertical axis is the Time and the colour is the Level.

The signal amplitude is represented in a scale of arbitrary colours, usually the darker the lower and the brighter the higher, like in thermography.

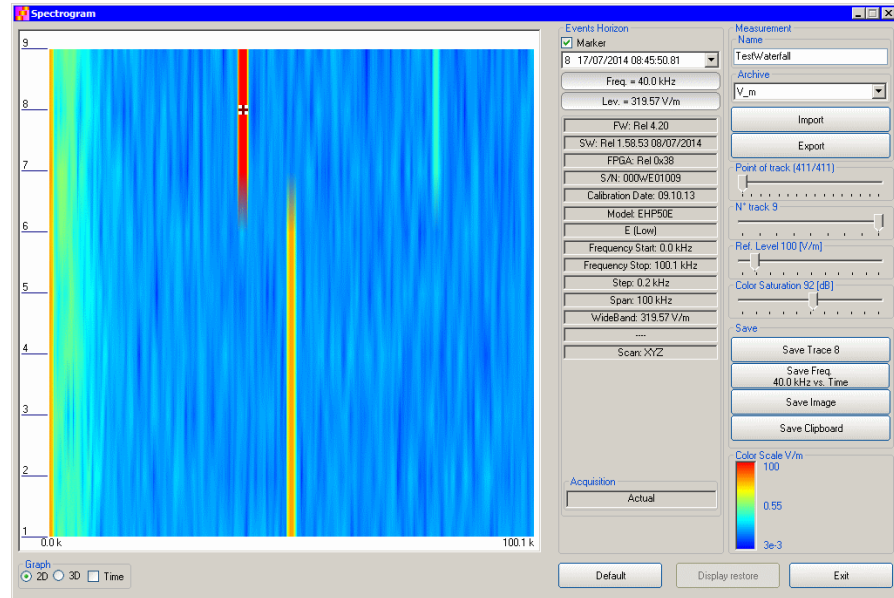
The Color Scale referenced to levels and units, is indicated on the right bottom of the screen.

The status-bar shows the number of tracks already acquired and the maximum available.

On the right two sliders permit to set the preferred Reference Level and Color Saturation (level dynamic range).

Press the **Default** button to reload standard settings.

When entering the **Open Waterfall** function a screen similar to the following appears:



**Fig.4-6 Waterfall Main Window**

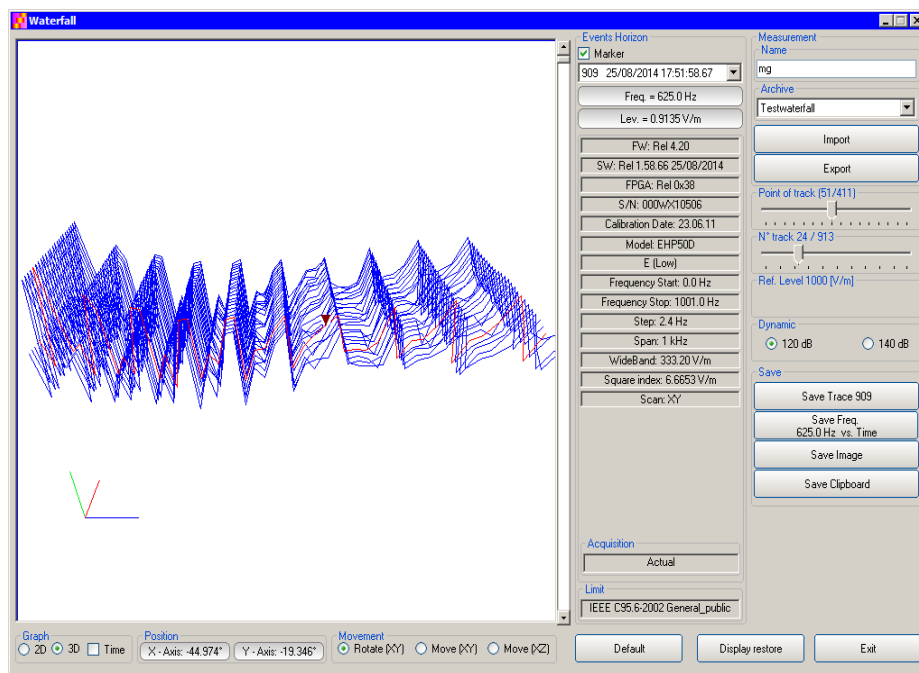
Like during the scan, on the left is the spectrogram of the measurements. The column in the middle, called Events Horizon, reports the Marker with its frequency and level and many parameters of the measurement setup and of the probe used.

On the right, in addition to Ref. Level and Color Saturation, there are two more sliders, useful to set the frequency resolution (Point of Track) and the time interval (N° track).

It is also possible to Import or Export a full acquisition by pressing the corresponding button in the Archive box. The name of the measurement can be typed in the Name box and from the list it is possible to select an already saved one.

In the Save box two or four buttons (depending on the marker activation) can be pressed to save:

- a single trace (Levels vs Frequencies)
- a single Frequency (Levels vs Time)
- an image of the spectrogram
- the clipboard



**Fig.4-7 Waterfall - Graph 3D**

In the **Graph 3D**, one axis (blue) represents Frequency, another the Level (green) and the third the Time (red). So the Frequency can be on the horizontal axis, the Level on the vertical axis and the Time in depth.

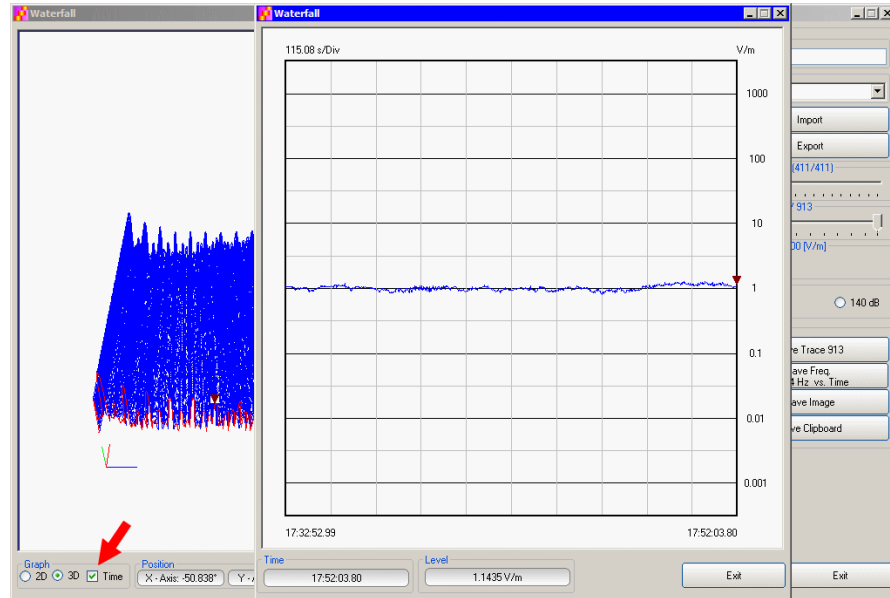
For this mode, another box, called **Movement**, will appear. Selecting the appropriate functions, you can move, rotate or zoom the view to your liking, using the mouse.

Another option of the **Graph 3D**, the Time plot, is available when the Marker is active.

Tick the Time label to enter this view.

A new window pops up and the plot represents the level at the marker frequency versus time.

The horizontal axis of the grid is the time and the vertical axis is the field level.



The Marker can be moved with the mouse to look for the desired frequency.

In the 3D view also the dynamic can be selected between 120 and 140 dB, to help for the best identification of disturbances.

#### **4.6.1.1 Data recording**

The subsequent spectra are automatically recorded and saved in a single file \*.WF5 localized in the folder Waterfall in the program root, inclusive of all the analyzer settings.

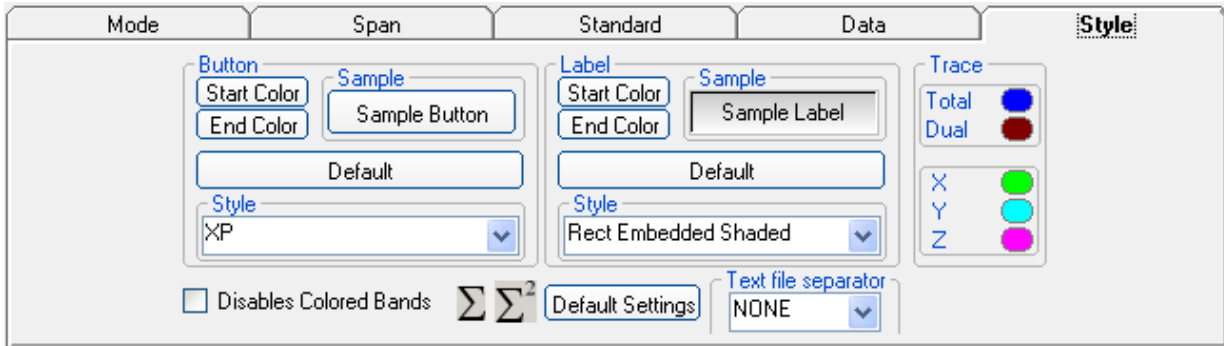
The stored files can be recalled when in Data mode or at startup entering the Open Waterfall window.

The filename is set by the operator prior to starting the test and it is indicated at the upper right corner of the Waterfall window.

The maximum number of spectra that can be recorded is of 30.000 and it is indicated, together with the current track number, in the status bar of the Waterfall window.

**4.7 Style section**

This unit concerns the appearance of the program.



Buttons and labels styles can be selected from a **Style** list

**Start** and **End Color** buttons allow selection from a color palette

**Sample Button** and **Sample Label** show the appearance preview

**Default** button to set appearance to the default parameters

**Trace** to set trace colours by means of the colour palette

**Text file separator** allow to specify column separator

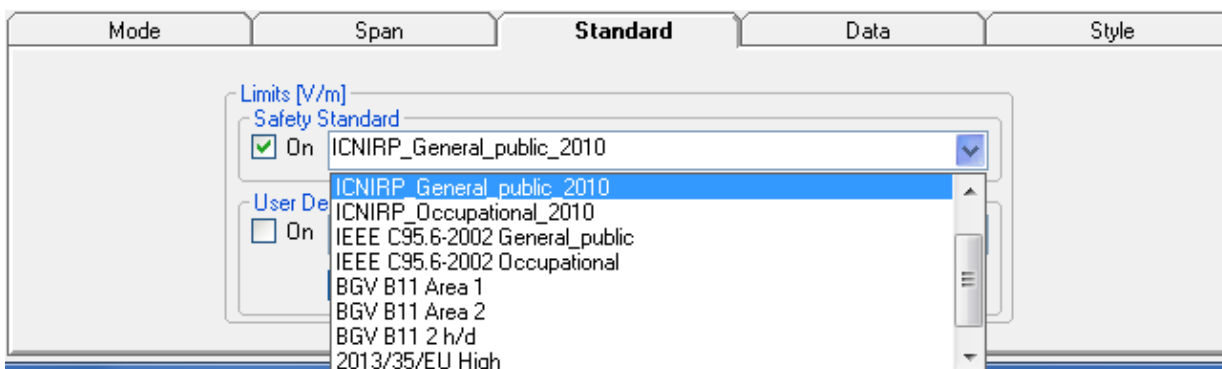
Tick the **Disable colored bands** box to avoid highlighting the bands for which the software calculates the ICNIRP values.


Press **Default Settings** button to completely restore the initial aspect.

#### 4.8 ICNIRP

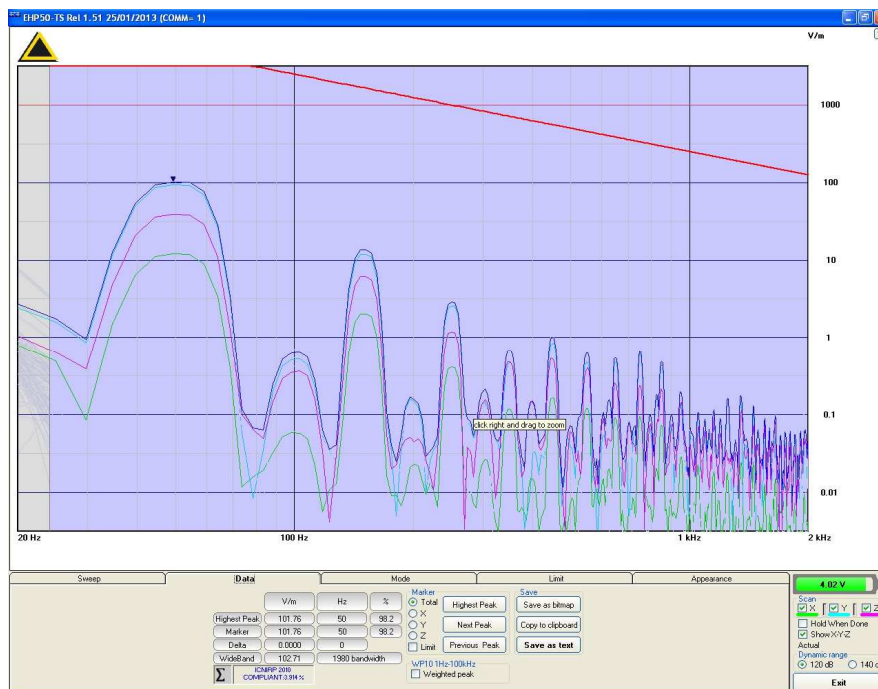
The **International Commission on Non-Ionizing Radiation Protection** establishes guidelines for limiting EMF exposure that could affect human health.


Standard section allows the user to select **standard ICNIRP limits**, already included by the software installation.



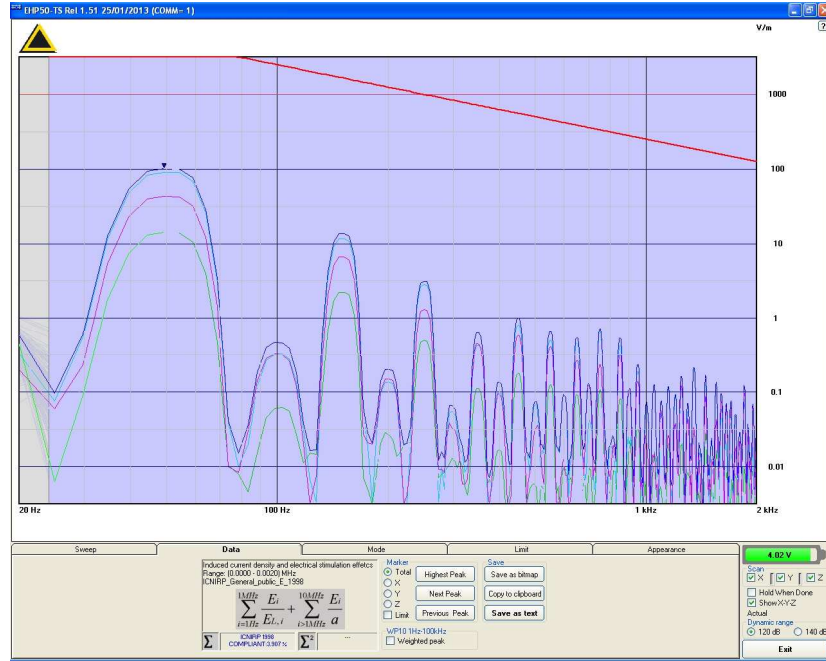
 **NOTE**

When the **ICNIRP limit** is selected, the software automatically calculates the corresponding total integration of the measured signals, and compares the result with the threshold set by the standard, considering whether it is or is not exceeded.

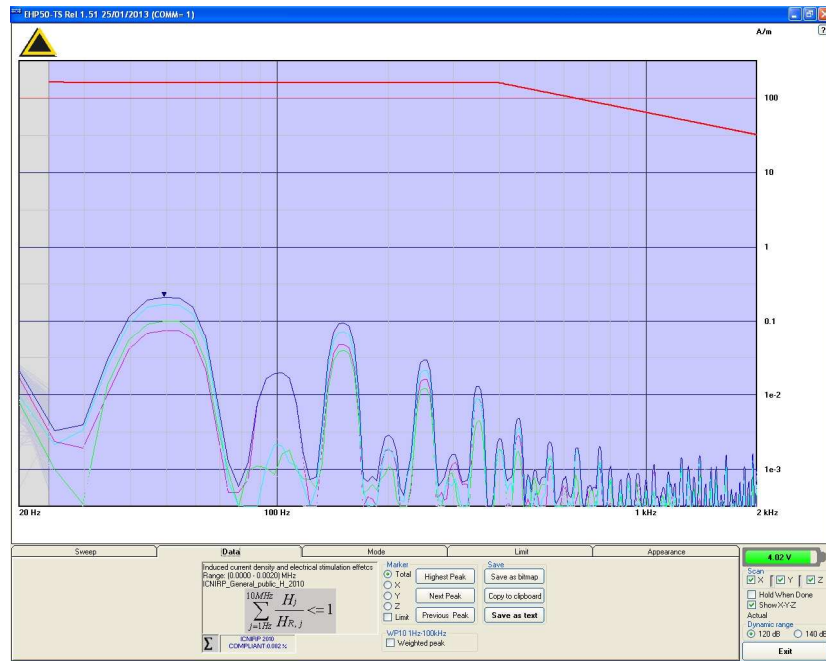


 **NOTE**

The calculation of the ICNIRP value is performed if all three axes are enabled



In the screenshot above it is depicted an example how the software shows the calculation of the ICNIRP value for the Electric Field measurement.



In the screenshot above it is depicted an example how the software shows the calculation of the ICNIRP value for the Magnetic Field measurement.

**NOTE**

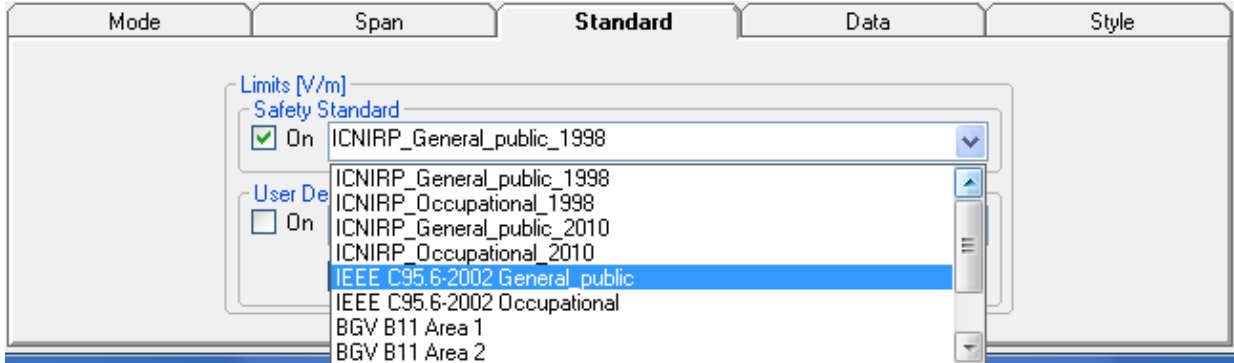
**The limit cannot be activated when using Dual Mode.**



4.9 IEEE

One of the purposes of the **Institute of Electrical and Electronic Engineers, Inc. ("IEEE")** is to establish exposure standards.

Standard section allows the user to select **standard IEEE limits**, already included by the software installation.

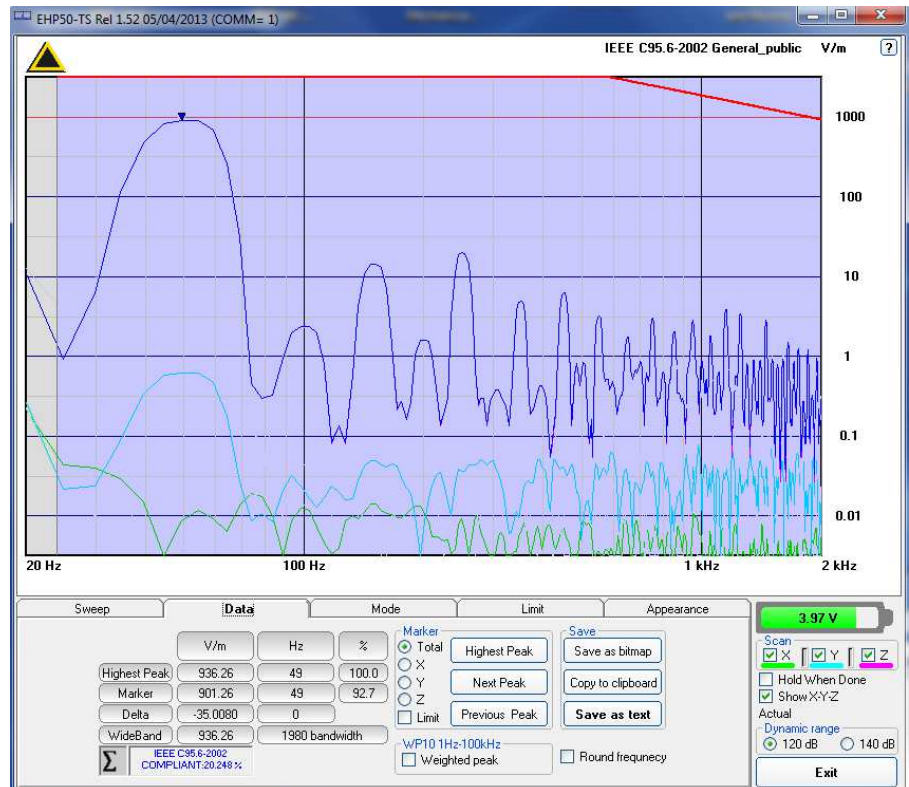


NOTE

When the **IEEE limit** is selected, the software automatically calculates the corresponding total integration of the measured signals, and compares the result with the threshold set by the standard, considering whether it is or is not exceeded.

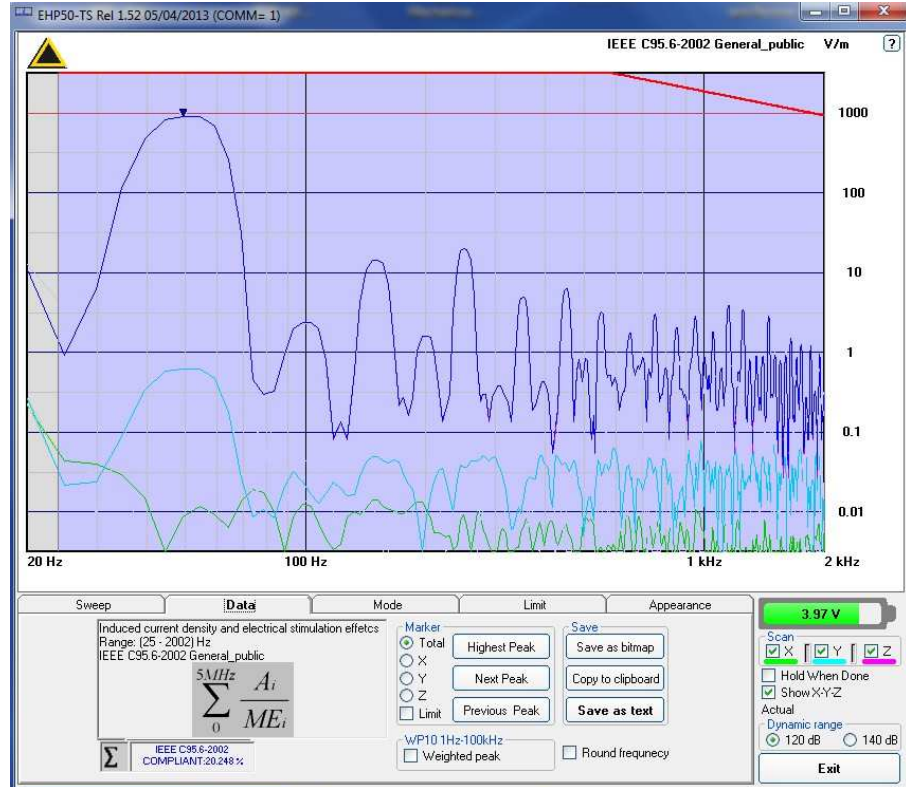
NOTE

**With coherent signals the result can be overestimated**



NOTE

The calculation of the IEEE value is performed if all three axes are enabled



In the screenshot above it is depicted an example how the software shows the calculation of the IEEE value for the Electric Field measurement.

**NOTE**

**The limit cannot be activated when using Dual Mode.**

#### 4.10 Weighted Peak Function (Time Domain)

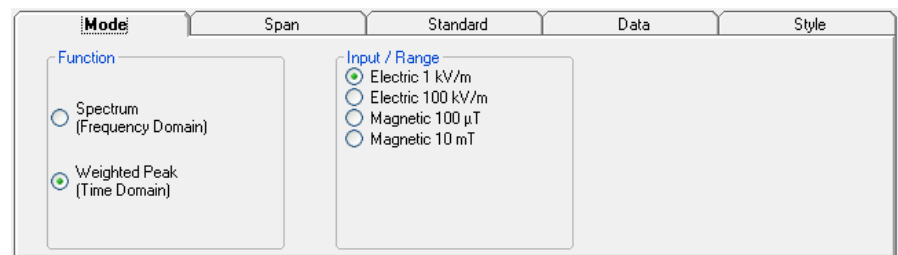
The EHP-50F Weighted Peak (Time Domain) option performs test in the range 1 Hz to 400 kHz to comply with the informative annex of the ICNIRP Guidelines 2010 (appendix “**Determination of the weighted peak exposure**”) for coherent signal source.

The current legislation proposes limits for electromagnetic fields, the value of which depends on the frequency.

When exposed to a sinusoidal field, it is relatively simple to relate the measurement of the field to the reference limit, as the frequency is known or easily measurable.

In case of multi-frequency fields, pulsed, non-sinusoidal waveforms, the exposure assessment in relation to the limit becomes more complex. In these cases, typical of industrial environments, it is not possible to relate the amplitude of the field to the limit value at a specific frequency, as the spectral content of the signal can be very complex (many frequencies are present at the same time).

The ICNIRP guidelines propose a method for the evaluation of multi-frequency fields, that consists of the sum of the field strength of the individual spectral components related to the limit corresponding to the frequency of each individual component. This method is appropriate in the presence of incoherent components.

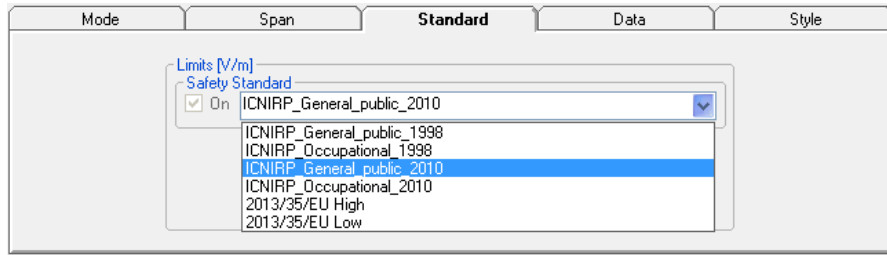


##### 4.10.1 Weighted Peak requirements

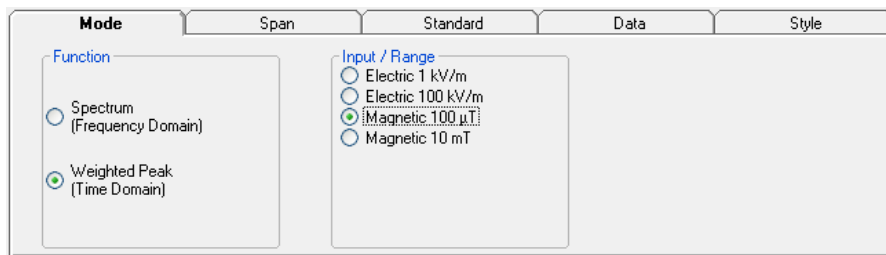
The Weighted Peak function needs the following in the list order:

- In the Mode Section, select the Function “Weighted Peak (Time Domain)”
- In the Standard section set one of the available standards, such as, for example, the ICNIRP 2010 limits for occupational or general public exposure.
- In the Mode section select one of the ranges among the Electric 1 kV/m, Electric 100 kV/m, Magnetic 100uT or Magnetic 10mT.
- In the Data section, enter the desired Hold Time.

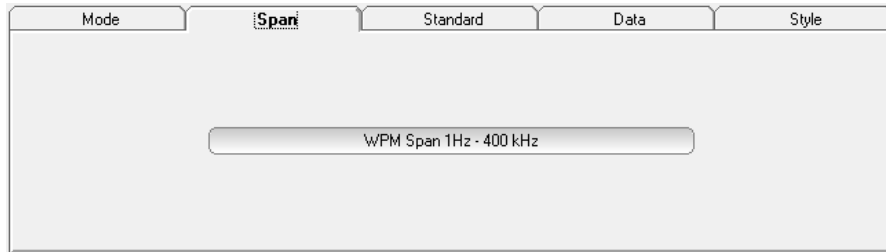
**4.10.2 EHP50-TS Settings** The **Standard** section allows the user to select one of the **standard ICNIRP or EU limits** for occupational or general public exposure, already included by the software installation.



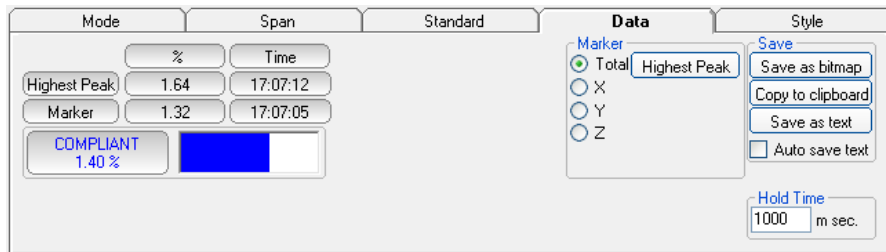
In the **Mode** section you can select **Electric 1 kV/m** or **Electric 100 kV/m** or **Magnetic 100uT** or **Magnetic 10mT**.



The **Span** section displays the frequency range, which is always full range 1 Hz to 400 kHz in Weighted Peak Mode.

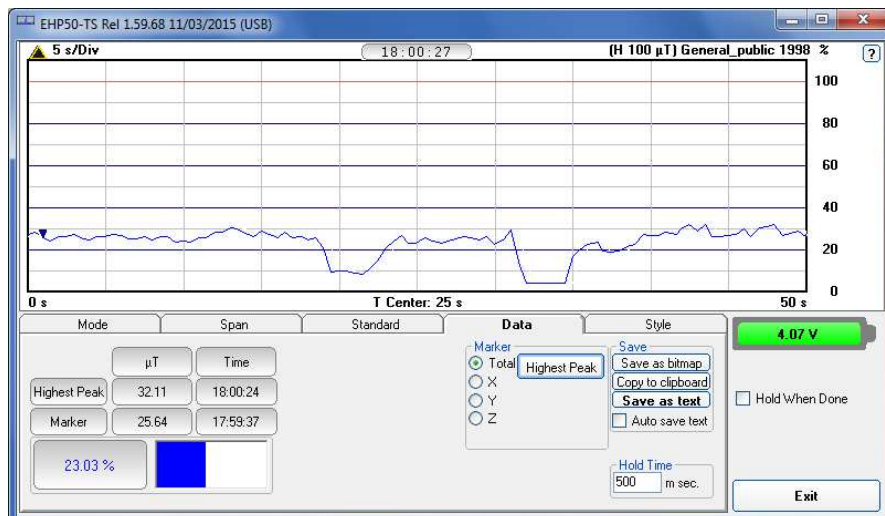


The **Data** section allows the user to read the measurements for the highest peak and Marker, to choose the axis and set the desired Hold Time.



### 4.10.3 Weighted Peak mode

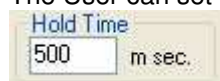
Once the Weighted Peak has been enabled, the software shows the result of the calculation and its graph over the time.



Result in percentage over the set hold time




The User can set the Hold Time (in milliseconds):



The Hold Time is the time resolution of the graph. During the Hold Time the Weighted Peak results will be collected and the maximum value will be shown in the graph.

Press the enter key to enter the Hold time value.

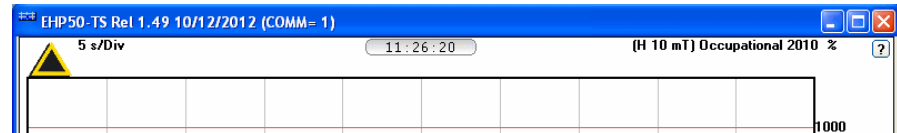
 NOTE

The minimum hold time is of 500 milliseconds.

The maximum is 10 minutes.

The time span of the graph is 200 times the hold time. The rolling measurement memory deletes all values that date back longer than the set time period.

The limit selected is shown in the higher right corner of the graph.



The full scale is automatically adapted to the field and the limit selected.

In the centre, above the grid of the graph, the time indication is the actual time, the instant in which the measurement is made, at the end of the hold time step.

#### 4.10.3.1 Noise indication

The User should make use the following information to choose the proper setting for the desired measurement.

For every situation, the best choice is to adopt the lower Full Scale available (for example 100  $\mu$ T) until the meter indicates an over-range warning; when it happens, the User should switch the meter to the higher Full Scale setting (as for the example above, 10 mT).

#### Electric Field (E)


Standard	Range	Noise indication
ICNIRP 1998 Gen.Pub.	Low	2.5%
	High	10%
ICNIRP 1998 Occup.	Low	1.5%
	High	5%
ICNIRP 2010 Gen.Pub.	Low	2%
	High	10%
ICNIRP 2010 Occup.	Low	1.5%
	High	10%
2013/35/EU Low	Low	1.5%
	High	10%
2013/35/EU High	Low	1%
	High	2.5%

The table above shows the noise for each standard and setting, for Electric field measurements.


#### Magnetic field (H)

Standard	Range	Noise indication
ICNIRP 1998 Gen.Pub.	Low	1.5%
	High	10%
ICNIRP 1998 Occup.	Low	2.5%
	High	25%
ICNIRP 2010 Gen.Pub.	Low	1%
	High	5%
ICNIRP 2010 Occup.	Low	1.5%
	High	10%
2013/35/EU Low	Low	1.5%
	High	10%
2013/35/EU High	Low	1.5%
	High	10%
2013/35/EU Limbs	Low	1%
	High	5%

The table above shows the noise for each standard and setting, for magnetic field measurements.

 **NOTE**

For convenience, a noise threshold has been established, under which the field indication becomes “LOW”, as in the example below.

Mode	Span	Standard	Data	Style
	<input type="text" value="μT"/> <input type="text" value="Time"/>		Marker <input checked="" type="radio"/> Total <input type="text" value="Highest Peak"/> <input type="radio"/> X <input type="radio"/> Y <input type="radio"/> Z	Save <input type="button" value="Save as bitmap"/> <input type="button" value="Copy to clipboard"/> <input type="button" value="Save as text"/> <input type="checkbox"/> Auto save text
	<input type="button" value="Highest Peak"/> <input type="text" value="32.11"/> <input type="text" value="18:00:24"/>			Hold Time <input type="text" value="500"/> m sec.
	<input type="button" value="Marker"/> <input type="text" value="25.64"/> <input type="text" value="17:59:37"/>			
	<input type="button" value="LOW"/> 			



## 5 - EHP-50F Stand alone mode

### 5.1 Stand alone mode description

EHP-50F has been designed to be used also in stand-alone mode. This mode is useful because no external devices is necessary to the analyzer during measurements. Once the measurement parameters have been programmed through a PC, the EHP-50F analyzer can start its acquisition by storing the data over 24 hours in a stand-alone mode. It is necessary to position it over the TR-02A tripod and to activate the start. After 24 hours it will stop automatically and later it would be possible to download all the data to the PC by using the provided EHP50-TS PC software. From PC it is possible to select to measure the electric or magnetic field, to select the range, the Highest or Wideband mode, the desired SPAN and the sampling rate of one minute or 30 seconds.

Some typical applications are:

- Magnetic fields near high, medium and low voltage transformers
- Measurements in proximity of power line
- Safety measurement at worker's site
- Measurements close to machines, air conditioning systems, home appliances etc.
- Development of new products

To start the stand-alone acquisition it is necessary to follow this procedure:

- Turn OFF the EHP-50F.
- Remove the fiber optic connected to PC.
- Insert the small optical bridge connector into the fiber receptacle of EHP-50F.
- Position it on TR-02A tripod or use the small tripod supplied with EHP-50F (the provided 50cm extention rod must be used, specially in case of Electric field measurement, to avoid any influence from the support plane).
- Turn on EHP-50F by pushing the Red **POWER** button for one second (**ORANGE** LED for about 1 second is shown on button press). After that, the led turns off for 2 seconds, lights orange for about ½ second as an auto-check. Then you will see the led flashing red and green for about one minute.
- Go away from the analyzer in order not to influence the measurement.
- Wait 24 hours for the completion of the one-day measurement.
- The led of EHP-50F will flash every second to inform that it is ON with **GREEN** light. After every minute (or 30 sec) the led will become **ORANGE** for the time requested by the analyzer to perform one measurement. The time that the led remain orange will depend on the selected SPAN. Lower Spans require longer measurement time.



Fig. 5-1 Shorting loop

### NOTE

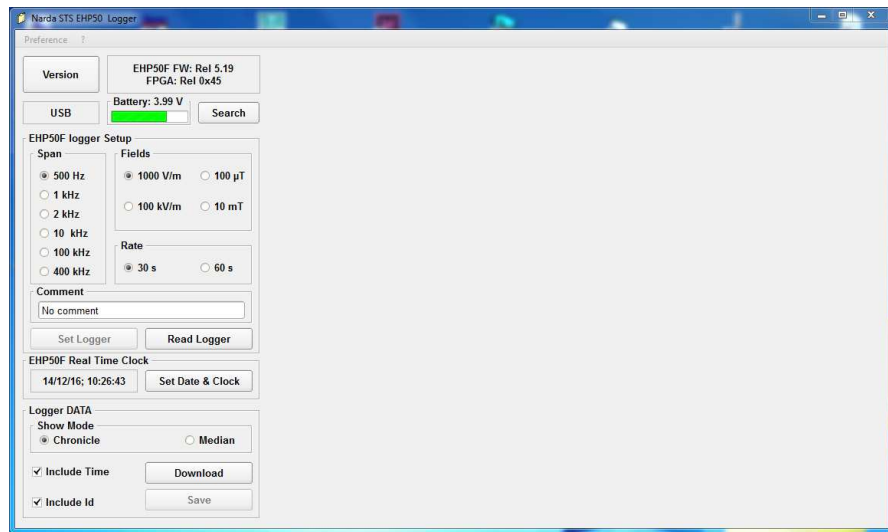
**The acquisition can be terminated earlier than 24 hours. Just turn off the EHP-50F and run the application to download the data to the PC.**

## 5.2 EHP-50F Data Logger

Once the data has been collected by EHP-50F, you should connect it to the PC to download all measurement results.

### 5.2.1 Run EHP-50F-Stand Alone mode software

Run “EHP-50F Stand Alone mode” application

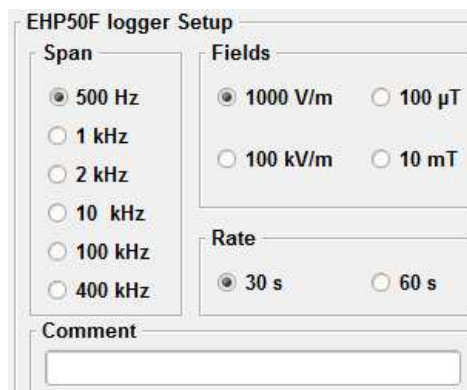


During the communication process for searching the analyzer EHP-50F, the following messages will appear in sequence for a few seconds:



To define measurement parameters for a new stand alone acquisition you may need to select:

- **(Span)** The Span
- **(Fields)** The electric or magnetic field with the proper range
- **(Rate)** The Storing Rate
- **(Comment)** To Insert the user’s comments

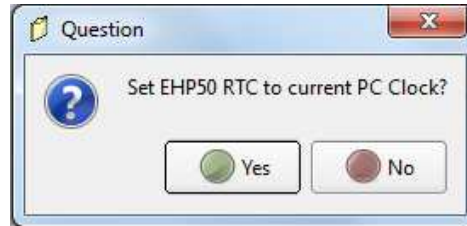


The **Read Logger** will not be available unless the communication between the PC and the analyzer has been established. Click this button to read the actual EHP-50F setup.

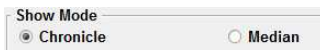
The **Set Logger** window will not be available unless you change some parameters. The **Set Logger** will be active and available for the user to transfer all measurement parameters (setup) to the EHP-50F internal memory.



It is possible to set the date & clock inside the EHP-50F by transferring the actual date & time of your PC. Pushing the button **Set Date & Clock** you will get the following window:



Answering YES, the date & time of your PC will be transferred inside the analyzer.



The measurement results can be shown in two modes:

**Chronicle:** the data are ordered by increasing time like in the following example:

Logger Started 14/12/16; 10:11:29 Rate: 30s.

Time	Wide X V/m	Wide Y V/m	Wide Z V/m	Wide T V/m	High X V/m	High Y V/m	High Z V/m	High T V/m	Freq. Hz
10:11:30	0.947	2.658	17.398	17.625	0.906	2.529	17.378	17.584	50.00
10:12:00	0.819	2.138	17.179	17.331	0.818	2.136	17.179	17.331	50.00
10:12:30	0.844	2.128	17.159	17.311	0.841	2.126	17.159	17.311	50.00
10:13:00	0.837	2.153	17.179	17.334	0.831	2.153	17.179	17.333	50.00
10:13:30	0.845	2.183	17.140	17.299	0.841	2.180	17.140	17.298	50.00
10:14:00	0.860	2.175	17.159	17.318	0.857	2.173	17.159	17.318	50.00
10:14:30	0.869	2.163	17.199	17.356	0.868	2.160	17.199	17.356	50.00
10:15:00	0.857	2.121	17.199	17.350	0.852	2.121	17.199	17.350	50.00
10:15:30	0.861	2.160	17.219	17.375	0.856	2.158	17.219	17.374	50.00
10:16:00	0.891	2.180	17.239	17.399	0.889	2.180	17.239	17.399	50.00

**Median:** the data are ordered from the lowest to the highest **WIDE T** value like in the following example:

Logger Started 14/12/16; 10:11:29 Rate: 30s.

Id	Time	Wide X V/m	Wide Y V/m	Wide Z V/m	Wide T V/m	High X V/m	High Y V/m	High Z V/m	High T V/m	Freq. Hz
1	10:20:30	0.400	3.228	15.631	15.966	0.398	3.225	15.631	15.966	50.00
2	10:19:30	0.392	3.228	15.649	15.984	0.387	3.228	15.649	15.984	50.00
3	10:20:00	0.391	3.255	15.668	16.007	0.385	3.255	15.668	16.007	50.00
4	10:21:30	0.391	3.210	15.686	16.015	0.385	3.210	15.686	16.015	50.00
5	10:18:30	0.414	3.304	15.668	16.017	0.407	3.304	15.668	16.017	50.00
6	10:19:00	0.402	3.232	15.686	16.020	0.396	3.228	15.686	16.019	50.00
7	10:22:00	0.405	3.225	15.704	16.036	0.399	3.225	15.704	16.036	50.00
8	10:18:00	0.405	3.289	15.704	16.049	0.399	3.289	15.686	16.032	50.00
9	10:22:30	0.412	3.251	15.722	16.060	0.406	3.251	15.704	16.042	50.00
10	10:21:00	0.415	3.304	15.722	16.070	0.406	3.300	15.722	16.069	50.00

<input checked="" type="checkbox"/> Include Time	<input type="button" value="Download"/>
<input checked="" type="checkbox"/> Include Id	<input type="button" value="Save"/>

If the checkbox **Include Time** is activated, the absolute time will be shown together with the collected data

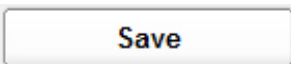
If the checkbox **Include Id** is activated, a number representing the position of the data inside the EHP-50F memory will be shown, like in the following example.

Logger Started 14/12/16; 10:11:29 Rate: 30s.

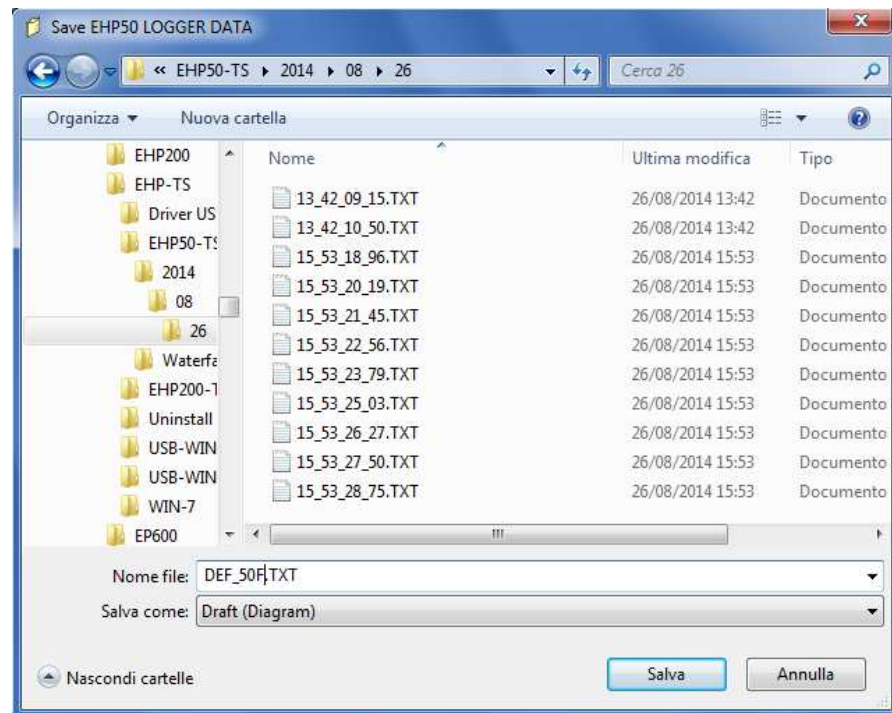
Id	Time	Wide X	Wide Y	Wide Z	Wide T	High X	High Y	High Z	High T	Freq. Hz
		V/m	V/m	V/m	V/m	V/m	V/m	V/m	V/m	
1	10:11:30	0.947	2.658	17.398	17.625	0.906	2.529	17.378	17.584	50.00
2	10:12:00	0.819	2.138	17.179	17.331	0.818	2.136	17.179	17.331	50.00
3	10:12:30	0.844	2.128	17.159	17.311	0.841	2.126	17.159	17.311	50.00
4	10:13:00	0.837	2.153	17.179	17.334	0.831	2.153	17.179	17.333	50.00
5	10:13:30	0.845	2.183	17.140	17.299	0.841	2.180	17.140	17.298	50.00
6	10:14:00	0.860	2.175	17.169	17.318	0.857	2.173	17.169	17.318	50.00
7	10:14:30	0.869	2.163	17.199	17.356	0.868	2.160	17.199	17.356	50.00
8	10:15:00	0.857	2.121	17.199	17.350	0.852	2.121	17.199	17.350	50.00
9	10:15:30	0.861	2.160	17.219	17.375	0.856	2.158	17.219	17.374	50.00
10	10:16:00	0.891	2.180	17.239	17.399	0.889	2.180	17.239	17.399	50.00



Push the button **Download** to transfer all data from the analyzer to the PC



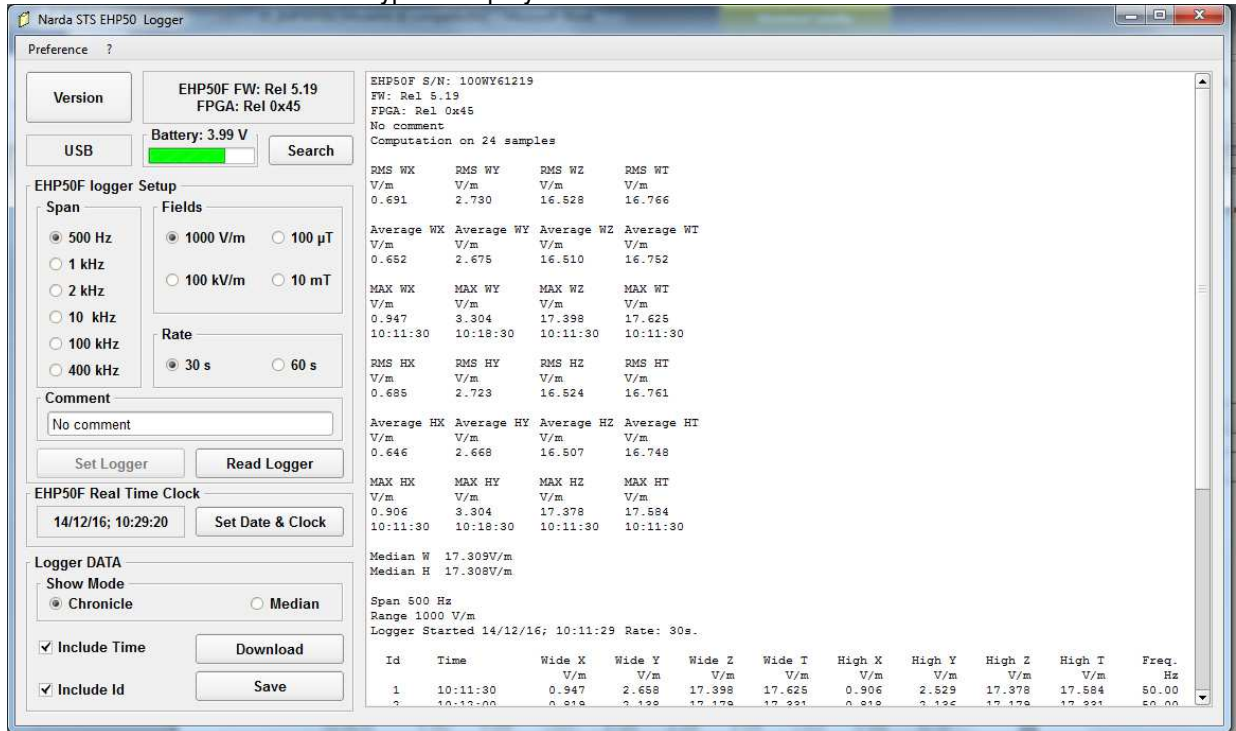
To save the data into your own PC directory, it is necessary to activate the button **Save**.  
Data will be saved in TXT format according to the following window:



### 5.2.2 Use EHP-50F Logger

When the communication between the PC and the analyzer has been established, push the button **Download** to transfer all data from the analyzer to the PC.  
To use such data you must save them into a file.

A typical display will be:



On the right side of the display, the software shows:

- Serial number of EHP-50F
- Firmware and FPGA release of EHP-50F
- The comment that you wrote inside the memory of EHP-50F typing few words in the **Comment** window
- Number of samples stored
- RMS, Average, MAX and Median values in Highest and Wide mode
- Span used during the acquisition
- Range
- Starting date and time
- All values collected

### 5.2.3 EHP-50F battery charging

If the battery charger is plugged to the EHP-50F while the software is running, the analyzer will be disconnected and the software will display:



and the led is flashing quickly.

#### NOTE

**During the charging process, always remove the bridge connector from the EHP-50F**

**This page has been left blank intentionally**

## 6 – Updating firmware

### 6.1 Update firmware

The EHP-50F internal firmware can be updated easily by the user.

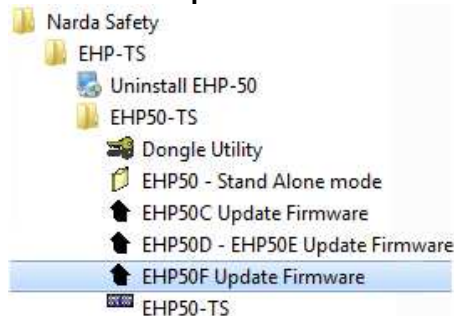
This section provides all the information required for firmware updating.

The Update Firmware Program is available after EHP50-TS package installation.

### 6.2 To run the update software

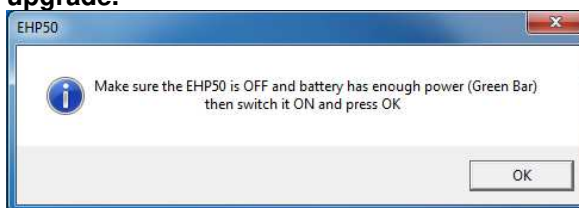
Turn off the EHP-50F and connect it to a free USB or RS232 port of the PC.

Run **EHP50F Update Firmware** to start the update program.



### NOTE

The User should check that the battery level is at least 3.9 V before starting the upgrade.



### 6.3 To transfer data

Main window displayed after the updating program **EHP-50F Update Firmware** has been run:



Fig.6-1 EHP-50F Upgrading Utility Main Window

Select USB or RS232 communication port.

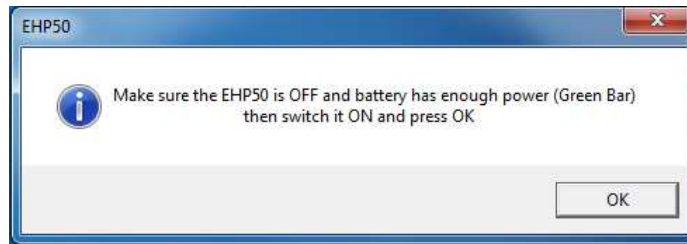
Before selecting RS232 port, choose the COM port used.

 NOTE

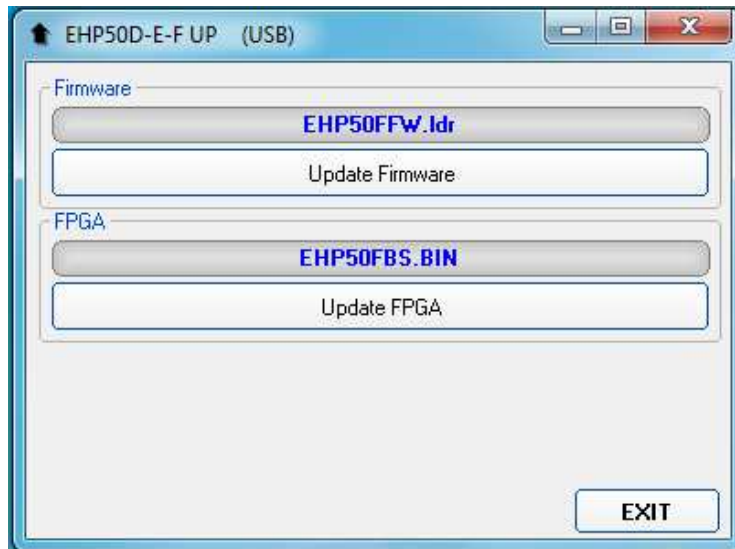
In case the software doesn't detect any EHP-50F in the USB port, the following message will be displayed.



As soon as the connection is established, a message informs to turn the EHP-50F **OFF** and turn it **ON** again; press **OK** to confirm.



Two firmware components can be updated by this application: Firmware, which is the main analyzer internal program, and FPGA, to update parameters of the analyzer Field Programmable Gate Array. Both files, required for updating, are automatically stored within the EHP-TS directory during EHP50-TS software installation. To start the process simply select **Update Firmware** or **Update FPGA** button, and wait (few minutes) until the automatic transfer is completed.








At the end, a message informs if the update has been successfully performed.

Turn the EHP-50F **OFF** (it could seem to be already OFF but it is not) and turn it **ON** again.

The EHP-50F is now updated with the new version of the internal firmware or FPGA.

It is now possible to disconnect the cable connected to the PC, with the EHP-50F meter either switched on or off.

Subsequently, when the meter is switched on again, the new version will be displayed in the NBM-550, EHP50-TS or EHP-50F Stand Alone Mode application software.

 **NOTE**

**To obtain firmware or FPGA or programs updates for EHP-50F, please contact your NARDA distributor or download it directly from the NARDA Web site: [www.narda-sts.it](http://www.narda-sts.it)**

**This page has been intentionally left blank**

## 7 – Uninstalling Software

### 7.1 Uninstalling EHP50-TS Software

It is possible to remove the EHP50-TS software from the PC according to the following procedure:

Run the **Uninstall EHP-50** utility.



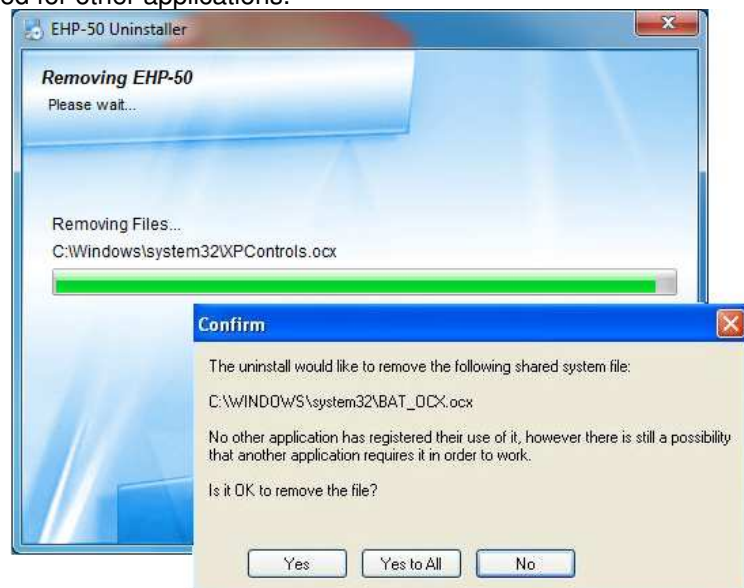
Follow the uninstaller instructions.



Fig. 7-1 Uninstalling EHP50-TS

Before removing any shared system file, the uninstaller will ask for a confirmation.

Answer "NO" in case you are not sure whether the showed system file is required for other applications.





EHP50-TS software is now removed from the system, click "Finish" to close uninstaller utility

## 8 – Uninstalling USB-OC

**8.1 Uninstalling driver for USB-OC** It is possible to remove the USB-OC driver from the PC according to the following procedure:

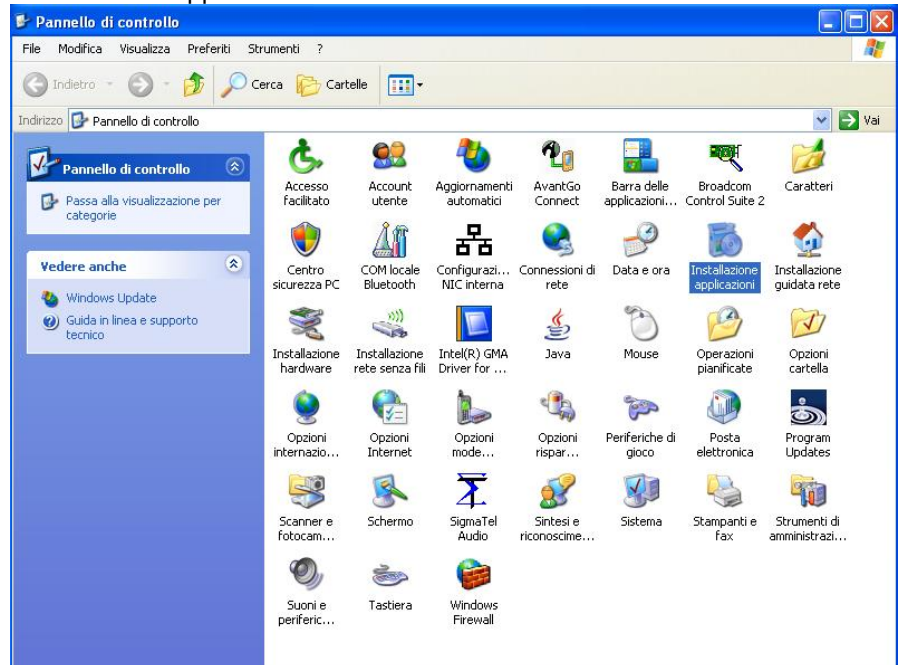
### NOTE

The following procedure shows how to remove the driver in Windows XP environment. It may be different depending on the operating system in use.

Open the Windows Control Panel.



Double click "Application Installation".



From the application list select “FTDI FTD2XX USB Drivers” and click “Change/Remove”.

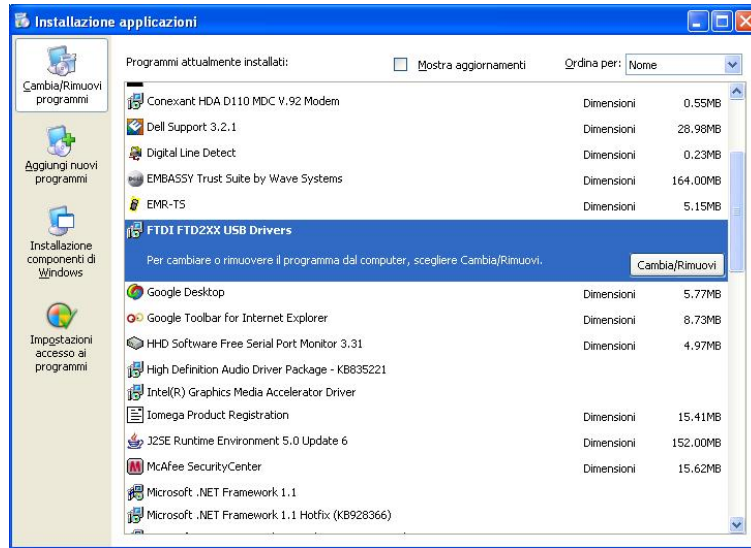
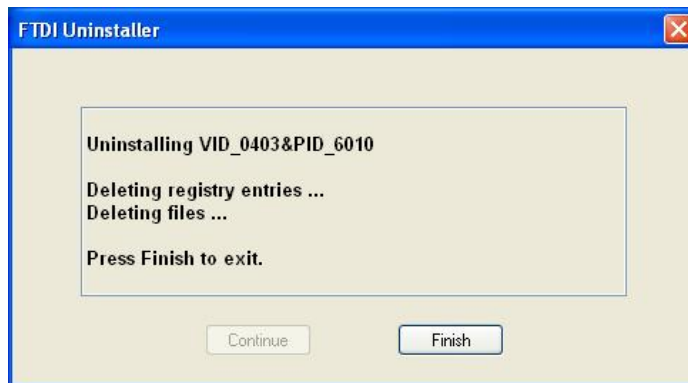


Fig.8-1 Uninstalling USB-OC

Unplug the USB-OC converter, if connected, and click “Continue”.



Click “finish” to exit the uninstaller, USB driver is now removed from your system.

## 9 - Accessories

### 9.1 Introduction

This section provides information required for installing and using accessories for EHP-50F Analyzer.

Information is included regarding initial inspection, power requirements, interconnections, work environment, assembly, cleaning, storage and shipment.

The following general information is applicable to all accessories.

#### 9.1.1 Preliminary inspection

Inspect the packaging for any damage.



**If the packaging or anti-shock material have been damaged, check that the contents are complete and that the product has not suffered electric or mechanical damage.**

**Check that all the Accessories are there against the checklist found with the apparatus.**

**Inform the carrier and NARDA of any damage that has occurred.**

#### 9.1.2 Work environment

Unless otherwise specified, the work environment of the Accessories, must come within the following conditions:

- Temperature From -10°C to +50° C (0°C to 40°C for Battery Charger)
- Humidity < 90% relative

The Accessories must be stored in a clean and dry environment, free from dust, acids and humidity.

The storage environment must come within the range of the following conditions:

- Temperature From -30°C to + 70°C (-20°C to 60°C for Battery Charger)
- Humidity < 95% relative

#### 9.1.3 Return for repair

When the Accessories need to be returned to NARDA for repair, please complete the questionnaire appended to this User's Manual, filling in all the data that will be useful for the service you have requested.

For reducing the period of time required for the repairs, it is necessary to be as specific as possible in describing the problem. If the problem only occurs in certain circumstances, please describe in detail how it happens.

If possible it is better to reuse the original packaging; making sure that the apparatus is wrapped in thick paper or plastic.

Otherwise, use strong packaging by using a sufficient quantity of shock absorbent material around all sides of the product to ensure that it is compact and does not move around inside the package.

In particular, take every precaution to protect the front panels.

Finish the package by sealing it up tightly.

Apply a FRAGILE label to the package to encourage greater care in its handling.

#### 9.1.4 Cleaning

Use a dry, clean and non-abrasive cloth for cleaning the instruments.



**Do not use solvents, acids, turpentine, acetone or other similar products for cleaning the devices in order to avoid damaging them.**

**9.1.5 Power supply and battery chargers**

EHP-50F accessories are powered by either internal rechargeable batteries or directly from other devices to which they are connected.

The AC/DC battery charger can be used with a power frequency at either 50 Hz or 60 Hz with a supply voltage between 100 and 240 AC Volt. International AC plug adapters are provided according to the various national standards.

AC plug adapter can be easily removed from the battery charger to be replaced by a different one.

To have the greatest autonomy, a full recharging cycle should be carried out before using the Accessories.

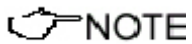
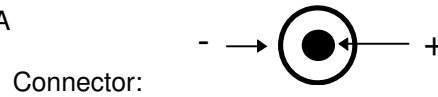


**NOTE**

**ALWAYS connect the battery charger to the mains BEFORE connecting to the charge input of the accessories.**

**The battery charger has an internal protective circuit that will break the output if any load is detected while connecting to the mains.**

Battery charger:  
output: DC, 10 - 15 V, ~ 500 mA



**NOTE**

**In order to preserve battery efficiency a complete recharge cycle is required before storing them for periods longer than 4 months. Therefore, it is warmly suggested recharging the batteries at least every 4 months even though the device has not been used.**



**NOTE**

**Software and Firmware updates for Accessories can be downloaded from the Web site <http://narda-sts.it>, <http://narda-sts.de>, or requested directly from NARDA Sales Centres.**



9.2

***NBM-550 Controller and Display Unit for EHP-50F***



**Fig. 9-1** NBM-550

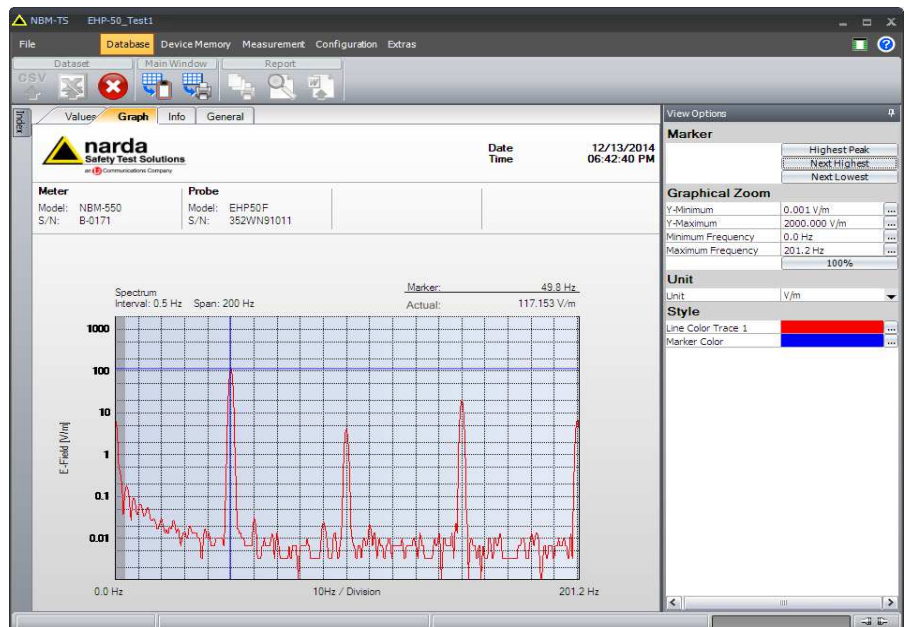
EHP-50F can be easily operated using the Broadband Field Meter NBM-550 as a controller and display unit. In order not to influence the field to be measured, communication between the EHP-50F Analyzer and the NBM Unit is through a rugged optical fiber cable. The NBM-550 supports the following settings and measurement modes:

- Electric or magnetic field selection (1 kV/m; 100 kV/m; 100  $\mu$ T; 10 mT)
- Span selection (100 Hz - 400 kHz)
- Wideband or highest peak modes
- Spectrum Mode
- Monitor Mode (Actual; Max; Avg; Min)
- XYZ Mode (wideband or highest peak)
- Weighted Peak (WPM) ranging from 1 Hz to 400 kHz

Additional features include:

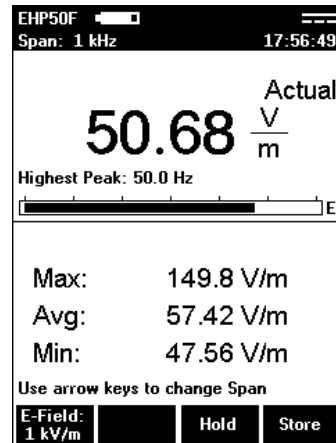
- Measurement setups
- Normalized spectrum in % related to a standard (e.g. ICNIRP)
- Alarm with adjustable thresholds for electric and magnetic field
- Averaging (4-32 samples) and Maximum Hold
- Unit selector for Tesla/Gauss
- Full resolution spectrum marker
- Data storage on NBM-550 including spectrum data
- Timer Logging
- Post-averaging for logged data on PC (RMS, Mean, Median)
- Powerful PC software NBM-TS for evaluation and documentation
- GPS receiver (optional)
- Operating languages:  
Chinese, English, French, German, Italian, Russian, Spanish, Turkish

For more information, please refer to the NBM-550 product information on the Narda website.

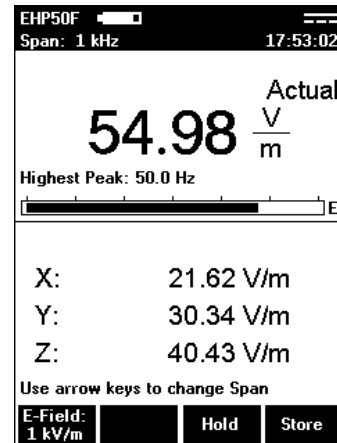


**Fig. 9-2** NBM-TS software supports evaluation and documentation of results that have been saved on NBM-550

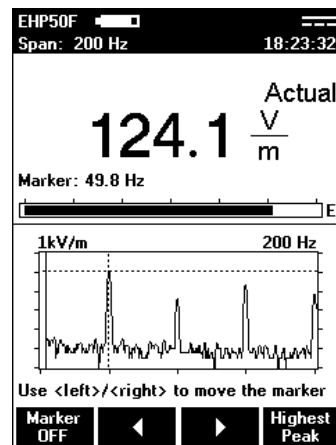
NBM-550 screenshots of EHP-50F results:



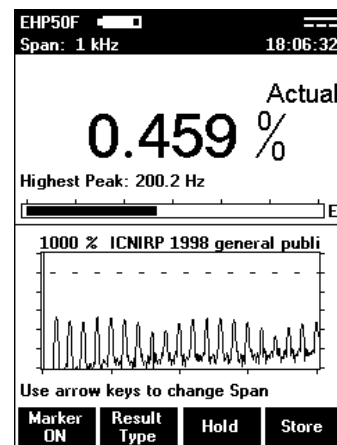
**Fig. 9-3** Monitor Mode



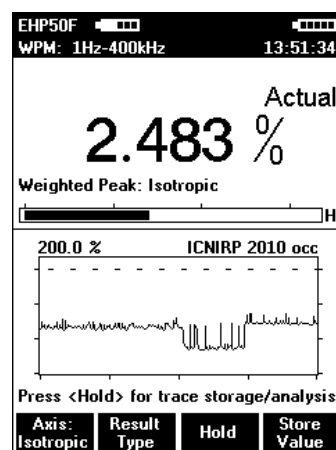
**Fig. 9-4** XYZ Mode



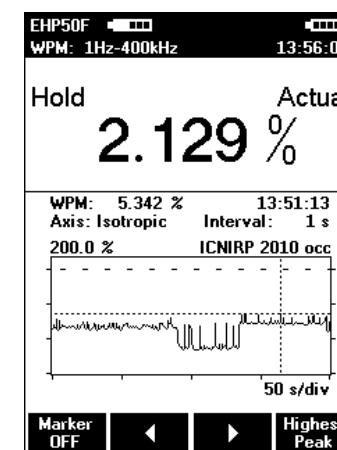
**Fig. 9-5** Spectrum Mode



**Fig. 9-6** Standard Mode (ICNIRP)



**Fig. 9-7** Weighted Peak Mode



**Fig. 9-8** Weighted Peak Marker

9.3

**USB-OC Optical USB Converter**

9.3.1 Introduction



USB-OC is standard accessory of the EHP-50F Analyzer. It converts the signals of some of the system's accessories, which are only connected via fiber optic, into USB-compatible signals. It, therefore, makes it possible to link the following items up to the USB port of any Personal Computer to operate them in conjunction with specific application software and for firmware updating:

- EHP-50F Electric and Magnetic Field Analyzers, 1 Hz – 400 kHz
- EHP-200A Electric and Magnetic Field Analyzers, 9 kHz – 30 MHz
- NBM-550 Broadband meter

Either USB-OC or 8053-OC is indispensable for updating the internal firmware of the above-mentioned items via a Personal Computer and the relative update software is available free-of-charge on NARDA's Web site at: <http://narda-sts.it>


9.3.2 Installation

Insert USB-OC in the connector of a free USB port of the PC, connect the fiber optic coming from the probe or other Accessories treating the locating key with care.

Considering the very low consumption of the device, the power required by USB-OC is taken directly from the USB port of the PC. This means no maintenance is needed.

**Table 9-1 Technical specifications of the USB-OC Optical USB Converter**

<b>Max. length of the fiber optic</b>	40 m
<b>USB Connector</b>	Type A Male

 **NOTE**

The link between USB-OC and a HUB USB device or USB cable extension could not work properly. Connect the USB-OC to the PC directly.

**Front view**



**Key:**

Fiber optic connector

**Rear view**



**Key:**

USB Type A Male

**Fig. 9-9** USB-OC adapters

**Power supply**

USB-OC is powered directly from the USB port of the PC.

**This page has been intentionally left blank**



**L3HARRIS**



**NARDA**  
Safety  
Test  
Solutions  
S.r.l. Socio Unico

**Sales & Support:**  
Via Rimini, 22  
20142 - Milano (MI)  
Tel.: +39 02 581881  
Fax: +39 02 58188273

**Manufacturing Plant:**  
Via Benessea, 29/B  
17035 Cisano sul Neva (SV)  
Tel.: +39 0182 58641  
Fax: +39 0182 586400



<http://www.narda-sts.it>

**Mod. 18-1**

**Caro cliente**

grazie per aver acquistato un prodotto NARDA! Sei in possesso di uno strumento che per molti anni ti garantirà un'alta qualità di servizio. NARDA riconosce l'importanza del Cliente come ragione di esistenza; ciascun commento e suggerimento, sottoposto all'attenzione della nostra organizzazione, è tenuto in grande considerazione. La nostra qualità è alla ricerca del miglioramento continuo. Se uno dei Suoi strumenti NARDA necessita di riparazione o calibrazione, può aiutarci a servirla più efficacemente compilando questa scheda e accludendola all'apparecchio.

Tuttavia, anche questo prodotto diventerà obsoleto. In questo caso, ti ricordiamo che lo smaltimento dell'apparecchiatura deve essere fatto in conformità con i regolamenti locali. Questo prodotto è conforme alle direttive WEEE dell'Unione Europea (2002/96/EC) ed appartiene alla categoria 9 (strumenti di controllo). Lo smaltimento, in un ambiente adeguato, può avvenire anche attraverso la restituzione del prodotto alla NARDA senza sostenere alcuna spesa. Può ottenere ulteriori informazioni contattando i venditori NARDA o visitando il nostro sito Web [www.narda-sts.it](http://www.narda-sts.it).

**Dear Customer**

thank you for purchasing a NARDA product! You now own a high-quality instrument that will give you many years of reliable service. NARDA recognizes the importance of the Customer as reason of existence; in this view, any comment and suggestion you would like to submit to the attention of our service organization is kept in great consideration. Moreover, we are continuously improving our quality, but we know this is a never ending process. We would be glad if our present efforts are pleasing you. Should one of your pieces of NARDA equipment need servicing you can help us serve you more effectively filling out this card and enclosing it with the product.

Nevertheless, even this product will become obsolete. When that time comes, please remember that electronic equipment must be disposed of in accordance with local regulations. This product conforms to the WEEE Directive of the European Union (2002/96/EC) and belongs to Category 9 (Monitoring and Control Instruments). You can return the instrument to us free of charge for proper environment friendly disposal. You can obtain further information from your local NARDA Sales Partner or by visiting our website at [www.narda-sts.it](http://www.narda-sts.it).

**Servizio richiesto:**  *Service needed:*

Solo taratura       Riparazione       Riparazione & Taratura       Taratura SIT       Altro:  
 Calibration only       Repair       Repair & Calibration       Certified Calibration       Other:

**Ditta:**

*Company:*

**Indirizzo:**

*Address:*

**Persona da contattare:**

*Technical contact person:*

**Telefono:**

*Phone n.*

**Modello:**

*Equipment model:*

**Numero di serie:**

*Serial n.*

**Accessori ritornati con l'apparecchiatura:**  **Nessuno**       **Cavo(i)**       **Cavo di alimentazione**       **Altro:**  
 *Accessories returned with unit:*       *None*       *Cable(s)*       *Power cable*       *Other:*

**Sintomi o problemi osservati:**  *Observed symptoms / problems:*

**Guasto:**  **Fisso**       **Intermittente**      **Sensibile a:**  **Freddo**       **Caldo**       **Vibrazioni**       **Altro**  
 *Failure:*  *Continuous*       *Intermittent*      *Sensitive to:*  *Cold*       *Heat*       *Vibration*       *Other*

**Descrizione del guasto/condizioni di funzionamento:**

*Failure symptoms/special control settings description:*

**Se l'unità è parte di un sistema descriverne la configurazione:**

*If unit is part of system please list other interconnected equipment and system set up:*

