

Service Manual



TDS3000B Series Digital Phosphor Oscilloscopes

071-0972-02

This document supports firmware version 3.00
and above for TDS3000B Series instruments only.

Warning

The servicing instructions are for use by qualified personnel only. To avoid personal injury, do not perform any servicing unless you are qualified to do so. Refer to all safety summaries prior to performing service.

www.tektronix.com

Copyright © Tektronix, Inc. All rights reserved.

Tektronix products are covered by U.S. and foreign patents, issued and pending. Information in this publication supercedes that in all previously published material. Specifications and price change privileges reserved.

Printed in the U.S.A.

Tektronix, Inc., P.O. Box 500, Beaverton, OR 97077

TEKTRONIX and TEK are registered trademarks of Tektronix, Inc.

Table of Contents

General Safety Summary	vii
Service Safety Summary	xi
Preface	xiii
Specifications	
Specifications	1-1
Operating Information	
Connecting Power	2-2
Installing an Application Module	2-7
Installing a Communication Module	2-8
Front-Panel Menus and Controls	2-9
Front-Panel Connectors	2-18
Rear-Panel Connectors	2-19
Communication Module Connectors	2-20
Probe Compensation	2-21
Self Calibration	2-22
Transporting the Oscilloscope	2-23
Theory of Operation	
Power Supply	3-1
Battery Board	3-2
Main Board	3-2
Display Module	3-3
Front-Panel Board	3-3
Disk Drive	3-3
Performance Verification	
Test Record	4-2
Performance Verification Procedures	4-4
Adjustment Procedures	
Required Equipment	5-1
Overview of the Adjustment Process	5-2
Signal Connections	5-3
Factory Adjustment Procedure	5-6

Maintenance

Preparation	6-1
Preventing ESD	6-1
Inspection and Cleaning	6-2
Removal and Installation Procedures	6-5
Troubleshooting	6-39
Troubleshooting Procedure	6-40
Unpacking and Repacking Instructions	6-43

Options

Options	7-1
---------------	-----

Electrical Parts List

Electrical Parts List	8-1
-----------------------------	-----

Diagrams

Diagrams	9-1
----------------	-----

Mechanical Parts List

Parts Ordering Information	10-1
Using the Replaceable Parts List	10-2

List of Figures

Figure 3-1: TDS3000B series block diagram	3-1
Figure 6-1: Pulling the hub pin	6-8
Figure 6-2: Releasing the hub assembly	6-9
Figure 6-3: Reinstalling a hub cover	6-11
Figure 6-4: Communication module guide	6-12
Figure 6-5: Main board disk drive flex cable connector J800	6-13
Figure 6-6: Removing the bezel from a new disk drive	6-14
Figure 6-7: Rear chassis cables to the main board	6-16
Figure 6-8: Installing the fan, line filter, and line power cable	6-18
Figure 6-9: Installing the AC line filter and shield	6-19
Figure 6-10: Installing the line filter and line power cable	6-20
Figure 6-11: Removing clip from J500 connector	6-22
Figure 6-12: Disconnect main board cable connectors	6-23
Figure 6-13: Main Board	6-24
Figure 6-14: Install clip on J500 connector	6-26
Figure 6-15: Front chassis	6-27
Figure 6-16: Display module	6-28
Figure 6-17: Front-panel cable routing	6-29
Figure 6-18: Disconnect back light cables	6-30
Figure 6-19: Remove inverter board	6-31
Figure 6-20: Remove display from display chassis	6-32
Figure 6-21: Remove back light tube	6-33
Figure 6-22: Installing display glass shield	6-34
Figure 6-23: Remove front-panel knobs	6-35
Figure 6-24: Remove front-panel board	6-36
Figure 6-25: Remove front-panel keypads	6-37
Figure 6-26: Checking front-panel lock nuts	6-38
Figure 6-27: Primary troubleshooting procedure	6-40
Figure 6-28: AC power supply troubleshooting procedure	6-41
Figure 6-29: Module isolation troubleshooting procedure	6-42

Figure 10-1: Exploded view, front case half	10-4
Figure 10-2: Exploded view, LCD display	10-6
Figure 10-3: Exploded view, main board and disk drive	10-8
Figure 10-4: Exploded view, circuit board assembly and fan	10-10
Figure 10-5: Exploded view, rear case half	10-13

List of Tables

Table 1-1: Specifications	1-1
Table 6-1: Internal inspection check list	6-3
Table 6-2: Removal and installation procedures	6-6
Table 7-1: TDS3000B Series options	7-1

General Safety Summary

Review the following safety precautions to avoid injury and prevent damage to this product or any products connected to it. To avoid potential hazards, use this product only as specified.

To Avoid Fire or Personal Injury

Use Proper Power Cord. Use only the power cord specified for this product and certified for the country of use.

Connect and Disconnect Properly. Connect the probe output to the measurement instrument before connecting the probe to the circuit under test. Disconnect the probe input and the probe ground from the circuit under test before disconnecting the probe from the measurement instrument.

Ground the Product. When operating with AC power, this product is grounded through the grounding conductor of the power cord. To avoid electric shock, the grounding conductor must be connected to earth ground. Before making connections to the input or output terminals of the product, ensure that the product is properly grounded.

When operating with battery power, this product must still be grounded. To prevent electric shock, always connect a grounding wire between the ground terminal on the rear panel and earth ground.

Observe All Terminal Ratings. To avoid fire or shock hazard, observe all ratings and markings on the product. Consult the product manual for further ratings information before making connections to the product.

Connect the ground lead of the probe to earth ground only.

Replace Batteries Properly. Replace batteries only with the proper type and rating specified.

Recharge Batteries Properly. Recharge batteries for the recommended charge cycle only.

Do Not Operate Without Covers. Do not operate this product with covers or panels removed.

Avoid Exposed Circuitry. Do not touch exposed connections and components when power is present.

Do Not Operate With Suspected Failures. If you suspect there is damage to this product, have it inspected by qualified service personnel.

Do Not Operate in Wet/Damp Conditions.

Do Not Operate in an Explosive Atmosphere.

Keep Product Surfaces Clean and Dry.

Provide Proper Ventilation. Refer to the manual's installation instructions for details on installing the product so it has proper ventilation.

Safety Terms and Symbols

Terms in this Manual. These terms may appear in this manual:



WARNING. *Warning statements identify conditions or practices that could result in injury or loss of life.*



CAUTION. *Caution statements identify conditions or practices that could result in damage to this product or other property.*

Terms on the Product. These terms may appear on the product:

DANGER indicates an injury hazard immediately accessible as you read the marking.

WARNING indicates an injury hazard not immediately accessible as you read the marking.

CAUTION indicates a hazard to property including the product.

Symbols on the Product. These symbols may appear on the product:

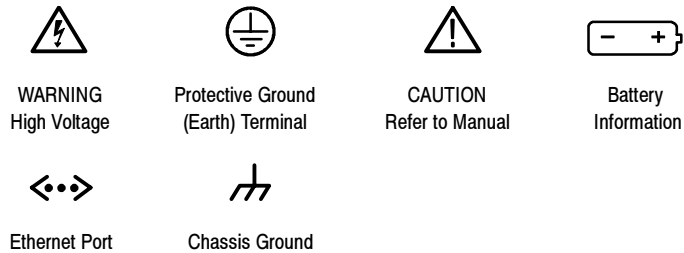

Preventing Electrostatic Damage



CAUTION. *Electrostatic discharge (ESD) can damage components in the oscilloscope and its accessories. To prevent ESD, observe these precautions when directed to do so.*

Use a Ground Strap. Wear a grounded antistatic wrist strap to discharge the static voltage from your body while installing or removing sensitive components.

Use a Safe Work Area. Do not use any devices capable of generating or holding a static charge in the work area where you install or remove sensitive components. Avoid handling sensitive components in areas that have a floor or benchtop surface capable of generating a static charge.

Handle Components Carefully. Do not slide sensitive components over any surface. Do not touch exposed connector pins. Handle sensitive components as little as possible.

Transport and Store Carefully. Transport and store sensitive components in a static-protected bag or container.

Product End-of-Life Handling

Observe the following guidelines when recycling an instrument:

Components that Contain Mercury. The cold cathode fluorescent tube located in the liquid crystal display backlight contains ≤ 5 milligrams of mercury. When you are ready to reclaim the instrument, you must properly transfer it according to local regulations concerning mercury-containing equipment, or ship the instrument to the Tektronix Recycling Operations (RAMS). You can contact Tektronix for the RAMS shipping address and instructions.

Battery Recycling. This product may contain a Lithium Ion (Li-Ion) rechargeable battery. Please dispose of the battery properly according to your local regulations.

This product may contain a Nickel Cadmium (Ni-Cd) battery, which must be recycled or disposed of properly. For the location of a local Ni-Cd battery recycler in the U. S. or Canada, please contact:

RBRC	Phone: 877-723-1297 (toll free)
Rechargeable Battery Recycling Corp.	Phone: 678-419-9990
1000 Parkwood Circle	Fax: 678-419-9986
Suite 450	Web: www.rbrc.com
Atlanta, GA 30339	

Service Safety Summary

Only qualified personnel should perform service procedures. Read this *Service Safety Summary* and the *General Safety Summary* before performing any service procedures.

Do Not Service Alone. Do not perform internal service or adjustments of this product unless another person capable of rendering first aid and resuscitation is present.

Disconnect Power. To avoid electric shock, switch off the instrument power, then disconnect the power cord from the mains power.

Use Care When Servicing With Power On. Dangerous voltages or currents may exist in this product. Disconnect power, remove battery (if applicable), and disconnect test leads before removing protective panels, soldering, or replacing components.

To avoid electric shock, do not touch exposed connections.

Preface

This is the Service Manual for the following TDS3000B Series Digital Phosphor Oscilloscopes:

- TDS3012B
- TDS3014B
- TDS3032B
- TDS3034B
- TDS3052B
- TDS3054B

This manual provides information to troubleshoot and repair the instrument to the module level.

Related Manuals

Additional documentation for the oscilloscope is contained on the *TDS3000B DPO Oscilloscope Manuals and Application Notes* CD (063-3486-00) that came with the oscilloscope.

Contacting Tektronix

Phone	1-800-833-9200*
Address	Tektronix, Inc. Department or name (if known) 14200 SW Karl Braun Drive P.O. Box 500 Beaverton, OR 97077 USA
Web site	www.tektronix.com
Sales support	1-800-833-9200, select option 1*
Service support	1-800-833-9200, select option 2*
Technical support	Email: techsupport@tektronix.com 1-800-833-9200, select option 3* 6:00 a.m. - 5:00 p.m. Pacific time

* **This phone number is toll free in North America. After office hours, please leave a voice mail message. Outside North America, contact a Tektronix sales office or distributor; see the Tektronix web site for a list of offices.**

Specifications

This appendix contains specifications for the TDS3000B Series oscilloscopes. All specifications are guaranteed unless noted as “typical.” Typical specifications are provided for your convenience but are not guaranteed. Specifications that are marked with the ✓ symbol are checked in *Performance Verification*.

All specifications apply to all TDS3000B models unless noted otherwise. To meet specifications, two conditions must first be met:

- The oscilloscope must have been operating continuously for twenty minutes within the operating temperature range specified.
- You must perform the Compensate Signal Path operation described on page 2-22 prior to evaluating specifications. If the operating temperature changes by more than 10° C, you must perform the Compensate Signal Path operation again.

Table 1-1: Specifications

Acquisition		
Acquisition modes	Sample (Normal), Peak detect, Envelope, and Average	
Single Sequence	<i>Acquisition mode</i>	<i>Acquisition stops after</i>
	Sample, Peak Detect	One acquisition, all channels simultaneously
	Average, Envelope	N acquisitions, all channels simultaneously, N is settable from 2 to 256 (or ∞ for Envelope)

Table 1-1: Specifications (cont.)

Inputs				
Input coupling	DC, AC, or GND Channel input remains terminated when using GND coupling.			
Input impedance, DC coupled	1 M Ω \pm 1% in parallel with 13 pF \pm 2 pF, TekProbe compatible 50 Ω \pm 1%; VSWR \leq 1.5:1 from DC to 500 MHz, typical			
Maximum voltage at input BNC (1 M Ω)	<i>Overvoltage category</i>		<i>Maximum voltage</i>	
	CAT I Environment (refer to page 1-11)		150 V _{RMS} (400 V _{pk})	
	CAT II Environment (refer to page 1-11)		100 V _{RMS} (400 V _{pk})	
For steady-state sinusoidal waveforms, derate at 20 dB/decade above 200 kHz to 13 V _{pk} at 3 MHz and above.				
Maximum voltage at input BNC (50 Ω)	5 V _{RMS} with peaks \leq \pm 30 V			
Maximum floating voltage	0 V from chassis (BNC) ground to earth ground, or 30 V _{RMS} (42 V _{pk}) only under these conditions: no signal voltages >30 V _{RMS} (>42 V _{pk}), all common leads connected to the same voltage, no grounded peripherals attached			
Channel-to-channel crosstalk, typical	Measured on one channel, with test signal applied to another channel, and with the same scale and coupling settings on each channel			
	Frequency range	TDS3012B TDS3014B	TDS3032B TDS3034B	TDS3052B TDS3054B
	\leq 100 MHz	\geq 100:1	\geq 100:1	\geq 100:1
	\leq 300 MHz	—	\geq 50:1	\geq 50:1
	\leq 500 MHz	—	—	\geq 30:1
Differential delay, typical	100 ps between any two channels with the same scale and coupling settings			

Table 1-1: Specifications (cont.)

Vertical				
Number of channels	<i>TDS3012B, TDS3032B, TDS3052B</i>		<i>TDS3014B, TDS3034B, TDS3054B</i>	
	2 plus external trigger input		4 plus external trigger input	
Digitizers	9-bit resolution, separate digitizers for each channel sample simultaneously			
SCALE Range (at BNC)	1 M Ω		50 Ω	
	1 mV/div to 10 V/div		1mV/div to 1 V/div	
Fine SCALE	Adjustable with $\geq 1\%$ resolution			
Polarity	Normal and Invert			
Position range	± 5 divisions			
✓ Analog bandwidth, 50 Ω (also typical at 1 M Ω with standard probe)	Bandwidth limit set to Full, operating ambient ≤ 30 °C, derate 1%/°C above 30 °C			
	<i>Scale range</i>	<i>TDS3012B TDS3014B</i>	<i>TDS3032B TDS3034B</i>	<i>TDS3052B TDS3054B</i>
	5 mV/div to 1 V/div	100 MHz	300 MHz	500 MHz
	2 mV/div to 4.98 mV/div	100 MHz	250 MHz	300 MHz
	1 mV/div to 1.99 mV/div	90 MHz	150 MHz	175 MHz
Calculated rise time, typical	—	3.5 ns	1.2 ns	0.7 ns
Analog bandwidth limit, typical	Selectable between 20 MHz, 150 MHz (not available on TDS3012B or TDS3014B plus external trigger input), or Full			
Lower frequency limit, AC coupled, typical	7 Hz for 1 M Ω , reduced by a factor of ten when using a 10X passive probe; 140 kHz for 50 Ω			

Table 1-1: Specifications (cont.)

Vertical			
Peak detect or Envelope pulse response, typical	Minimum width of pulse with amplitude of ≥ 2 div to capture 50% or greater amplitude		
	<i>Sample rates ≤ 125 MS/s</i>	<i>Sample rates ≥ 250 MS/s</i>	
	1 ns	1/sample rate	
DC gain accuracy	$\pm 2\%$, derated at $0.025\%/^{\circ}\text{C}$ for temperatures below $+18^{\circ}\text{C}$ and above $+30^{\circ}\text{C}$, in Sample or Average acquisition mode		
DC measurement accuracy	<i>Measurement type</i>	<i>DC Accuracy (in volts)</i>	
	Sample acquisition mode, typical	Absolute measurement of any waveform point, and High, Low, Max, and Min measurements.	$\pm [0.02^1 \times \text{reading} - (\text{offset} - \text{position}) + \text{offset accuracy} + 0.15 \text{ div} + 0.6 \text{ mV}]$
		Delta voltage between any two points on a waveform, and all other automatic measurements.	$\pm [0.02^1 \times \text{reading} + 0.15 \text{ div} + 1.2 \text{ mV}]$
Average acquisition mode (≥ 16 averages)		Absolute measurement of any waveform point, and High, Low, Max, and Min measurements.	$\pm [0.02^1 \times \text{reading} - (\text{offset} - \text{position}) + \text{offset accuracy} + 0.1 \text{ div}]$
		Delta voltage between two points on a waveform, and all other automatic measurements.	$\pm [0.02^1 \times \text{reading} + 0.05 \text{ div}]$
Offset range	<i>Scale range</i>	<i>Offset range</i>	
	1 mV/div to 9.95 mV/div	$\pm 100 \text{ mV}$	
	10 mV/div to 99.5 mV/div	$\pm 1 \text{ V}$	
	100 mV/div to 995 mV/div	$\pm 10 \text{ V}$	
	1V/div to 10 V/div	$\pm 100 \text{ V}$	
Offset accuracy, all ranges	$\pm [0.005 \times \text{offset} - \text{position} + 0.1 \text{ div}]^2$		

¹ **0.02 term (gain component) derated at $0.00025/^{\circ}\text{C}$ above 30°C**

² **You must convert both the constant offset and position terms to volts by multiplying them by the oscilloscope volts/div setting.**

Table 1-1: Specifications (cont.)

Horizontal				
Acquisition (horizontal) resolution	<i>Normal</i> (10,000 point record)		<i>Fast trigger</i> (500 point record)	
Maximum acquisition rate, typical	<i>TDS3012B</i> <i>TDS3014B</i>	<i>TDS3032B</i> <i>TDS3034B</i> <i>TDS3052B</i> <i>TDS3054B</i>	<i>TDS3012B</i> <i>TDS3014B</i>	<i>TDS3032B</i> <i>TDS3034B</i> <i>TDS3052B</i> <i>TDS3054B</i>
	400 wfms/s	700 wfms/s	2,600 wfms/s	3,600 wfms/s
Sample rate range	<i>TDS3012B</i> <i>TDS3014B</i>	<i>TDS3032B</i> <i>TDS3034B</i>	<i>TDS3052B</i> <i>TDS3054B</i>	
Normal	100 S/s to 1 GS/s	100 S/s to 2.5 GS/s	100 S/s to 5 GS/s	
Fast trigger	5 S/s to 1.25 GS/s	5 S/s to 2.5 GS/s	5 S/s to 5 GS/s	
Seconds/division range	4 ns/div to 10 s/div	2 ns/div to 10 s/div	1 ns/div to 10 s/div	
✓ Sample rate and delay time accuracy	±20 ppm over any ≥1 ms time interval			
Trigger				
External trigger input, typical	<i>TDS3012B, TDS3032B, TDS3052B:</i> 1 MΩ in parallel with 17 pF, TekProbe compatible <i>TDS3014B, TDS3034B, TDS3054B:</i> 1 MΩ in parallel with 52 pF, not TekProbe compatible			
External trigger maximum voltage	<i>Overvoltage category</i>		<i>Maximum voltage</i>	
	CAT I Environment (refer to page 1-11)		150 V _{RMS} (400 V _{pk})	
	CAT II Environment (refer to page 1-11)		100 V _{RMS} (400 V _{pk})	
For steady-state sinusoidal waveforms, derate at 20 dB/decade above 200 kHz to 13 V _{pk} at 3 MHz and above.				
External trigger maximum floating voltage	0 V from chassis (BNC) ground to earth ground 30 V _{RMS} (42 V _{pk}) only under these conditions: no signal voltages >30 V _{RMS} (>42 V _{pk}), all common leads connected to the same voltage, no grounded peripherals attached			
✓ Edge trigger sensitivity	<i>Source</i>		<i>Sensitivity</i>	
	Any channel, DC coupled		0.35 div from DC to 50 MHz, increasing to 1 div at oscilloscope bandwidth	

Table 1-1: Specifications (cont.)

Trigger		
Edge trigger sensitivity, typical	<i>Source</i>	<i>Sensitivity</i>
	External trigger	200 mV from DC to 50 MHz, increasing to 750 mV at 300 MHz
	External/10 trigger	500 mV from DC to 50 MHz, increasing to 3 V at 300 MHz
	Any channel, NOISE REJ coupled	3.5 times the DC-coupled limits
	Any channel, HF REJ coupled	1.5 times the DC-coupled limit from DC to 30 kHz, attenuates signals above 30 kHz
	Any channel, LF REJ coupled	1.5 times the DC-coupled limits for frequencies above 80 kHz, attenuates signals below 80 kHz
Trigger level range	<i>Source</i>	<i>Sensitivity</i>
	Any channel	±8 divisions from center of screen, ±8 divisions from 0 V if LF REJ trigger coupled
	External trigger	±800 mV
	External/10 trigger	±8 V
	Line	Fixed at the midlevel of the AC line
SET LEVEL TO 50%, typical	Operates with input signals ≥45 Hz	
Trigger level accuracy, typical	<i>Source</i>	<i>Sensitivity</i>
	Any channel	±0.2 divisions
	External trigger	±20 mV
	External/10 trigger	±200 mV
	Line	N/A
Trigger holdoff range	250.8 ns to 10 s	
Video trigger sensitivity, typical	Triggers on negative sync of NTSC, PAL, or SECAM signal	
	<i>Source</i>	<i>Sensitivity</i>
	Any channel	0.6 to 2.5 divisions of video sync tip
	External trigger	150 mV to 625 mV of video sync tip
	External/10 trigger	1.5 V to 6.25 V of video sync tip

Table 1-1: Specifications (cont.)

Trigger		
B Trigger	<i>Trigger After Time</i>	Trigger After B Events
Range	13.2 ns to 50 s	1 event to 9,999,999 events
Minimum time between arm and trigger, typical	5ns from the end of the time period and the B trigger event	5 ns between the A trigger event and the first B trigger event
Minimum Pulse Width, typical	—	B event width, 2 ns
Maximum Frequency, typical	—	B event frequency, 250 MHz
Display		
Display screen	6.5 in (165 mm) diagonal color liquid crystal	
Display resolution	640 horizontal by 480 vertical pixels	
Backlight intensity, typical	200 cd/m ²	
Display color	Up to 16 colors, fixed palette	
External display filter	Scratch-resistant tempered glass	
I/O ports		
Ethernet port	RJ-45 female connector 10BaseT	
Parallel printer port	DB-25 female connector, Centronics compatible	
GPIB interface	Available with optional accessory TDS3GV	
RS-232 interface	DB-9 male connector, available with optional accessory TDS3GV	
VGA signal output	DB-15 female connector, 31.6 kHz sync rate, EIA RS-343A compliant, available with optional accessory TDS3GV	
Probe compensator output, typical	5.0 V into $\geq 1 \text{ M}\Omega$ load, frequency = 1 kHz	
Miscellaneous		
Nonvolatile memory	Typical retention time ≥ 5 years for front-panel settings, unlimited for saved waveforms and setups	
Floppy disk	3.5 in, DOS format, 720 KB or 1.44 MB compatible	
Internal clock	Provides date/time stamp for stored data and the current time and date to the front panel, if enabled.	

Table 1- 1: Specifications (cont.)

Power sources	
AC line power	Operates the oscilloscope and charges the optional internal battery
Source voltage	90 V _{RMS} to 250 V _{RMS} , continuous range (CAT II)
Source frequency	47 Hz to 440 Hz
Power consumption	75 W maximum
Battery power	Optional accessory TDS3BAT, rechargeable NiCd battery pack
Operating time, typical	2 hours, depending on operating conditions
Battery charge time, typical	18 hours in the oscilloscope, 3 hours in the optional external charger TDS3CHG
Line fuse	Internal, not user replaceable
Environmental	
Temperature	Operating range (no disk installed): +5 °C to +50 °C Nonoperating range (no disk installed): -20 °C to +60 °C Typical operating range for floppy disks: +10 °C to +50 °C
Humidity	Operating range (no disk installed): 20% to 80% RH below 32 °C, derate upper limit to 21% RH at 50 °C Nonoperating range (no disk installed): 5% to 90% RH below 41 °C, derate upper limit to 30% RH at 60 °C Typical operating range for floppy disks: 20% to 80% RH below 32 °C, derate upper limit to 21% RH at 50 °C
Pollution Degree	Pollution Degree 2: Typical home or office environment.

Table 1-1: Specifications (cont.)

Environmental	
Altitude	Operating limit: 3000 m Nonoperating limit: 15,000 m
Random vibration	Operating: 0.31 g _{RMS} from 5 Hz to 500 Hz, 10 minutes on each axis Nonoperating: 2.46 g _{RMS} from 5 Hz to 500 Hz, 10 minutes on each axis
Drop resistance, typical	Survives a 152 mm (6 in) drop onto concrete with only cosmetic damage
Mechanical	
Size	Height: 176 mm (6.9 in), 229 mm (9.0 in) including handle Width: 375 mm (14.75 in) Depth: 149 mm (5.9 in)
Weight	Oscilloscope only: 3.2 kg (7.0 lbs) With accessories and carry case: 4.1 kg (9.0 lbs) When packaged for domestic shipment: 5.5 kg (12.0 lbs) Optional battery pack: 2 kg (4.5 lbs)

Table 1- 1: Specifications (cont.)

EMC certifications and compliances	
European Union	<p>Meets the intent of Directive 89/336/EEC for Electromagnetic Compatibility. Compliance was demonstrated to the following specifications as listed in the Official Journal of the European Communities:</p> <p>EN 61326, Annex D EMC requirements for Class A electrical equipment for measurement, control, and laboratory use ^{1,2}</p> <p>IEC 61000-4-2 Electrostatic discharge immunity IEC 61000-4-3 RF electromagnetic field immunity ³ IEC 61000-4-4 Electrical fast transient/burst immunity IEC 61000-4-5 Power line surge immunity IEC 61000-4-6 Conducted RF immunity ⁴ IEC 61000-4-11 Voltage dips and interruptions immunity EN 61000-3-2 AC power line harmonic emissions</p>
Australia/ New Zealand	<p>Meets the intent of Australian EMC Framework as demonstrated to the following specification:</p> <p>AS/NZS 2064.1/2</p>
Russian Federation	<p>This product was certified by the GOST ministry of Russia to be in compliance with all applicable regulations.</p>
U.S.A.	<p>Emissions do not exceed FCC Code of Federal Regulations 47, Part 15, Subpart B, Class A Limits</p>

- ¹ **Emissions that exceed the levels required by this standard may occur when this equipment is connected to a test object.**
- ² **To ensure compliance to the standards listed above, attach only high quality shielded cables to this instrument. High quality shielded cables typically are braid and foil types that have low impedance connections to shielded connectors at both ends.**
- ³ **The increase in trace noise is not to exceed 6 major divisions peak-to-peak while the instrument is subjected to a radiated field as defined in standard IEC 61000-4-3. Ambient fields of amplitude ≥ 3 V/m may induce triggering when the trigger threshold is offset less than 3 major divisions from ground reference.**
- ⁴ **The increase in trace noise is not to exceed 2 major divisions peak-to-peak while the instrument is subjected to a signal (defined in standard IEC 61000-4-6) that is injected into the AC main. Conducted noise of amplitude ≥ 3 V may induce triggering when the trigger threshold is offset less than 1 major division from ground reference.**

Table 1-1: Specifications (cont.)

Safety certifications and compliances	
EC Declaration of Conformity - Low Voltage (TDS3000B Series, P3010, and P6139A) (P3010 and P6139A)	Compliance was demonstrated to the following specification as listed in the Official Journal of the European Communities: Low Voltage Directive 73/23/EEC as amended by 93/68/EEC EN 61010-1/A2:1995 Safety requirements for electrical equipment for measurement, control, and laboratory use EN 61010-2-031:1995 Particular requirements for hand-held probe assemblies for electrical measurement and test equipment
Approvals (TDS3000B Series, P3010, and P6139A) (P3010 and P6139A)	UL3111-1 - Standard for electrical measuring and test equipment CAN/CSA C22.2 No. 1010.1 - Safety requirements for electrical equipment for measurement, control and laboratory use EN 61010-2-031:1995 - Particular requirements for hand-held probe assemblies for electrical measurement and test equipment
Installation/ Overvoltage Category Descriptions	Terminals on this product may have different installation category designations. The installation categories are: CAT III Distribution-level mains (usually permanently connected). Equipment at this level is typically in a fixed industrial location CAT II Local-level mains (wall sockets). Equipment at this level includes appliances, portable tools, and similar products. Equipment is usually cord-connected CAT I Secondary (signal level) or battery operated circuits of electronic equipment

Operating Information

This chapter provides an overview of the following topics:

- Connecting power and using the battery pack
- Installing an application module
- Installing a communication module
- Front-panel menus and controls
- Front- and rear-panel connectors
- Probe compensation
- Self calibration
- Transporting the oscilloscope

For more detailed information about operating information, see the *TDS3000B Series Digital Phosphor Oscilloscope User Manual*.

For information about unpacking and inspecting the instrument, see *Unpacking and Repacking Instructions* on page 6-43 of this manual.

Connecting Power

To connect a power cord, do these steps:

1. Open the strain relief clip and slip it onto the power cord.
2. Snap the strain relief into its hole in the rear panel of the oscilloscope.
3. Connect the power cord to the power input connector.

You can operate the oscilloscope from a grounded mains supply with line voltage between 90 V_{AC} and 250 V_{AC} and frequency between 47 Hz and 440 Hz. The oscilloscope is grounded through the power cord. The line fuse is internal and is not user replaceable.

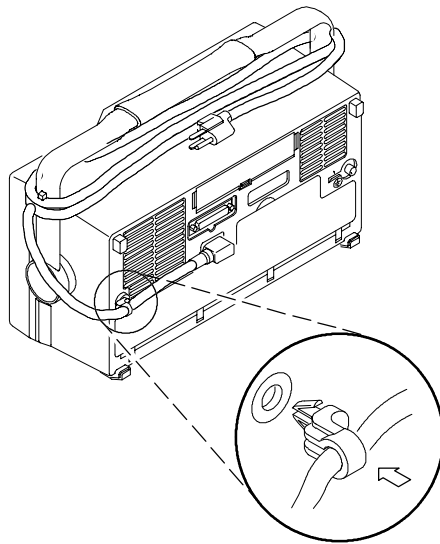

Using Battery Power

You can operate the oscilloscope continuously for approximately two hours from the rechargeable battery pack. A triangle icon in the display (\triangle) shows when the battery is in use, a power-plug icon ($\text{D}\sim$) shows when line power is connected, and a gauge icon (DP) shows the relative charge level in the battery. The oscilloscope turns off automatically when the battery runs low.

NiCd batteries appear to lose capacity if not allowed to occasionally discharge completely. Every few months, run your oscilloscope until it shuts down and then recharge the battery completely to keep your battery pack at peak performance.

Refer to the *General Safety Summary* for information about proper nickel-cadmium battery disposal.

Operating Safely with Battery Power



WARNING. To avoid electric shock, always connect the rear-panel ground terminal to earth ground when operating the instrument from battery power.

For safe operation, the oscilloscope chassis must remain at earth ground potential even when operating from battery power. Without a connection between the chassis and earth ground, you can receive a shock from exposed metal on the chassis if you connect an input to a hazardous voltage ($>30 V_{RMS}$, $>42 V_{pk}$). To protect against this condition, attach the Tektronix-supplied grounding wire from the terminal on the rear panel to earth ground. If you use a different grounding wire, it must be larger than 18 gauge (1 mm^2).

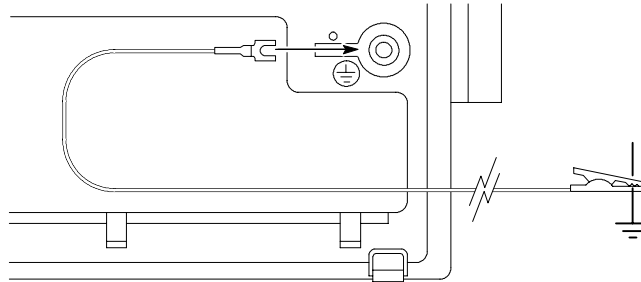

When you start to use the battery pack, an on-screen message reminds you to connect the grounding wire between the ground terminal on the rear panel and earth ground.

Installing and Removing the Battery

To install the optional battery pack, do these steps:

1. Open the battery compartment door on the rear panel and remove the accessory tray.

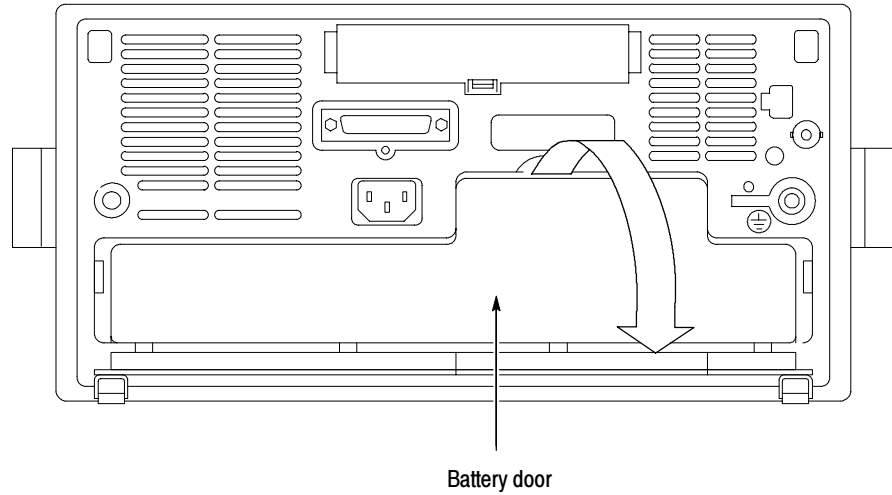

2. Slide the battery into the compartment and press it in from both sides until you hear the latches click.
3. Press on both sides of the battery compartment door to snap it closed.

To remove the battery, do these steps:

1. Open the battery compartment door.
2. Lift the battery handles and pull the battery out of the oscilloscope.

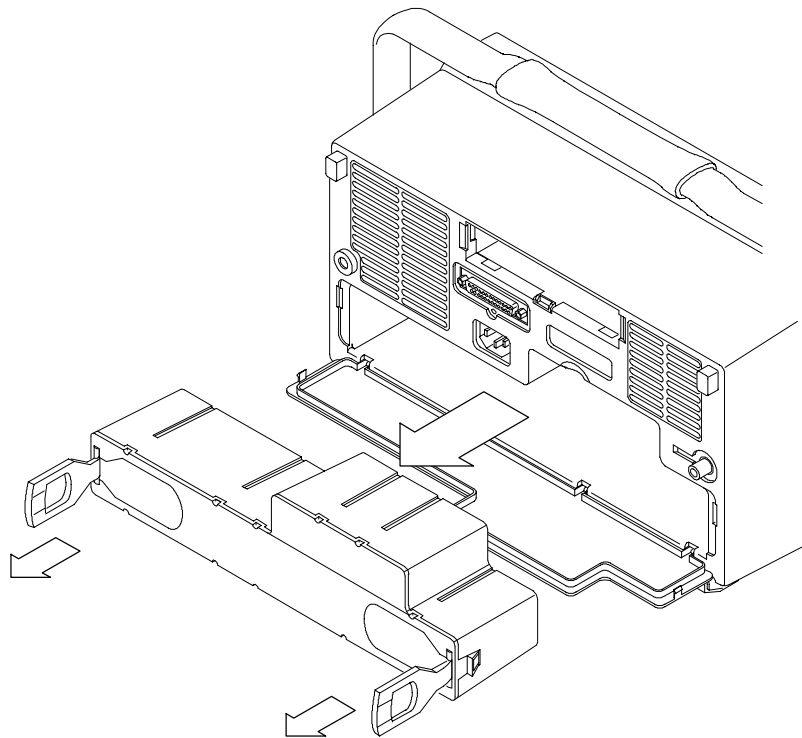

Charging the Battery

The battery charges automatically when the oscilloscope is connected to line power. You can also charge the battery with the optional external charger (TDS3CHG).

Configuration	Typical charging time
Battery charging in oscilloscope with oscilloscope turned on or off	18 hours
Battery charging with TDS3CHG external charger	3 hours

NOTE. Charge the battery before using it for the first time or after prolonged storage.

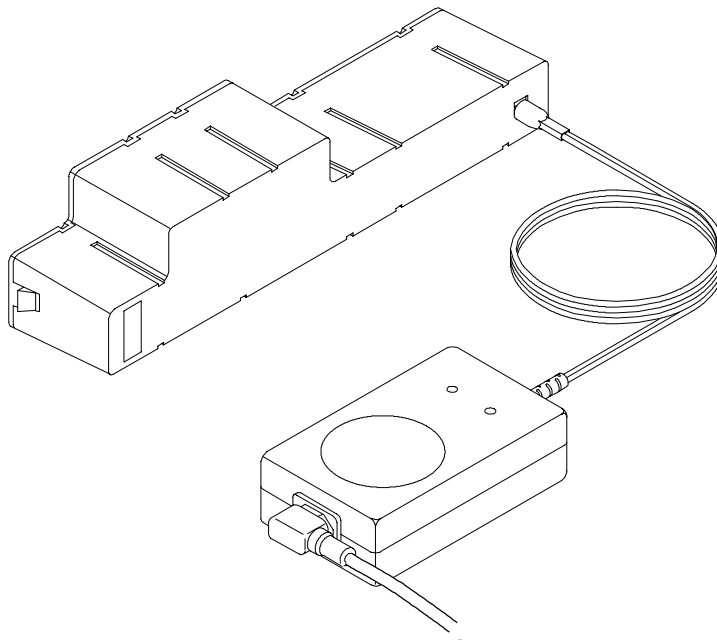

Installing an Application Module



CAUTION. To avoid damage to the oscilloscope or application module, observe the ESD precautions described on page ix.

Optional application packages are available to extend the capability of your oscilloscope. You can install up to four application modules at one time. Application modules can go into the two slots with windows in the upper right corner of the front panel. Two additional slots are directly behind the two you can see.

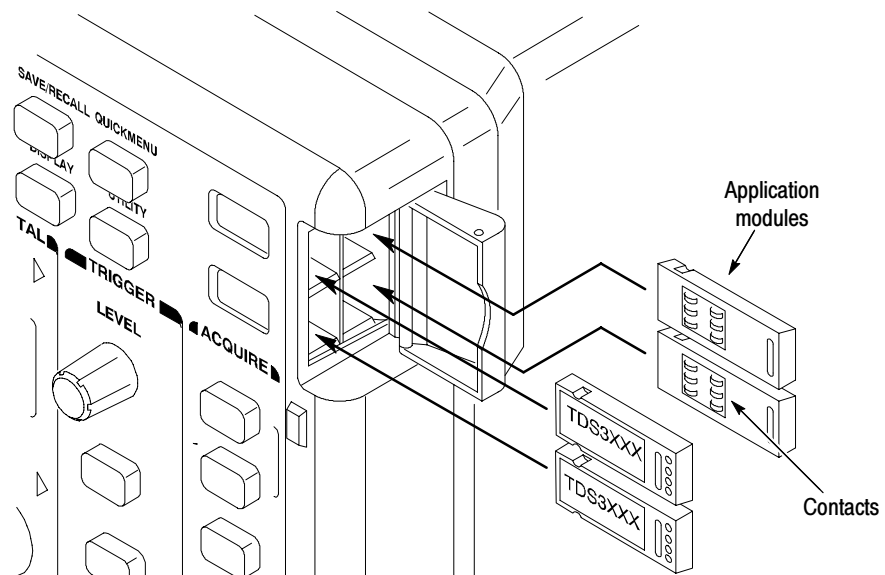

Refer to the *TDS3000 & TDS3000B Series Application Module Installation Instructions* that came with your application module for instructions on installing and testing an application module.

NOTE. If you remove an application module, the features provided by the application module become unavailable. You can reinstall the module to restore the features.

Installing a Communication Module



CAUTION. To avoid damage to the oscilloscope or communication module, observe the ESD precautions described on page ix.

To install one of the optional communications modules, do these steps:

1. Turn the oscilloscope power off.
2. Press down on the latching tab to remove the blank cover.
3. Slide the communication module into the compartment until the internal connectors are seated and the latching tab locks.
4. Turn power on. The communication module is now ready for your use.

To remove a communication module, do these steps:

1. Turn the oscilloscope power off.
2. Press down on the latching tab and then use a small screwdriver to alternately pry out the sides of the communication module.
3. Slide out the communication module and store it in an ESD-shielded bag. Install the blank cover if no other communication module is to be installed.

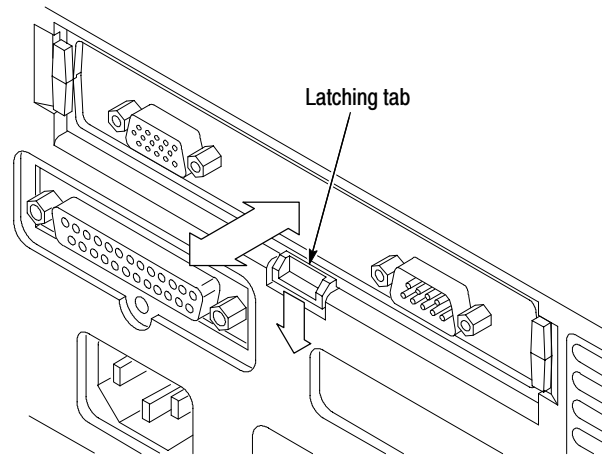

Front-Panel Menus and Controls

The front panel has buttons and controls for the functions you use most often. The front panel has menus to access more specialized functions.

Using the Menu System

To use the menu system, follow the steps shown on the next two pages.

1. Push a dark-colored front-panel menu button to display the menu you want to use.

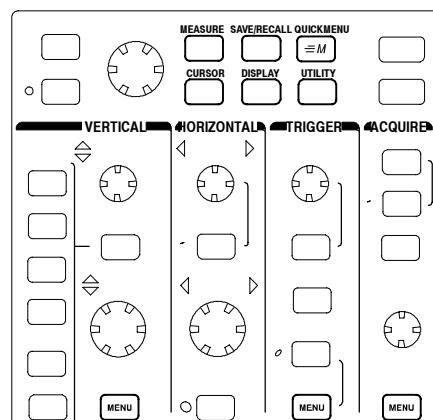

2. Push a bottom screen button to select a menu item. If a pop-up menu appears, continue to push the screen button to select an item from the pop-up menu.

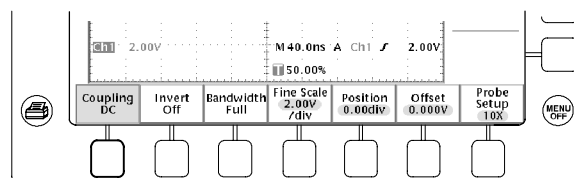

3. Push a side screen button to choose a menu item. If the menu item contains more than one choice, push the side screen button again to make the choice.

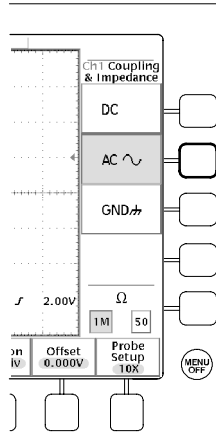

4. Certain menu choices require you to set a numerical value to complete the setup. Use the general purpose knob to adjust the parameter value. Push the COARSE button to make larger adjustments.

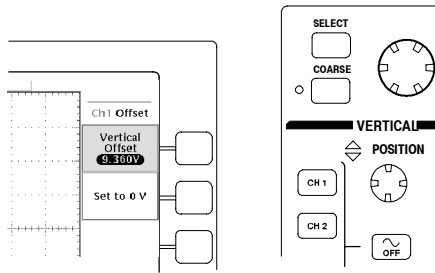

Using the Menu Buttons

You can use the menu buttons to perform many functions in the oscilloscope.

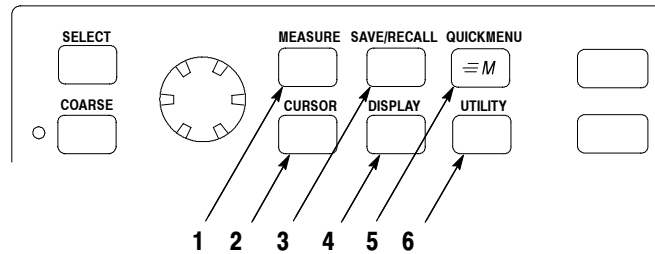

1. **MEASURE.** Performs automated measurements of waveforms.
2. **CURSOR.** Activates the cursors.
3. **SAVE/RECALL.** Saves and recalls setups and waveforms to memory or a floppy disk.
4. **DISPLAY.** Changes the appearance of waveforms and the display screen.
5. **QUICKMENU.** Activates QuickMenus such as the built-in Quick Scope feature.
6. **UTILITY.** Activates the system utility functions, such as selecting a language.

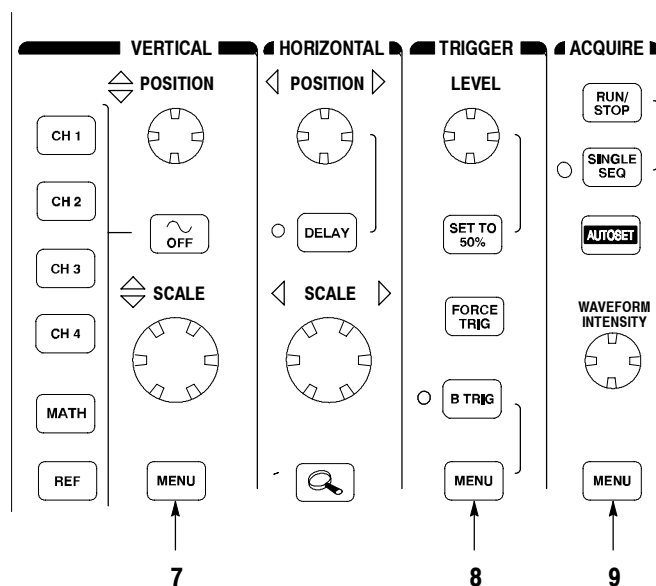

7. Vertical MENU. Adjusts the scale, position, and offset of waveforms. Sets the input parameters.
8. Trigger MENU. Adjusts the trigger functions.
9. Acquire MENU. Sets the acquisition modes and horizontal resolution, resets the delay time, and accesses the WaveAlert™ menu.

Using the Dedicated Controls

These dedicated buttons and controls generally control waveforms and cursors without the use of menus.

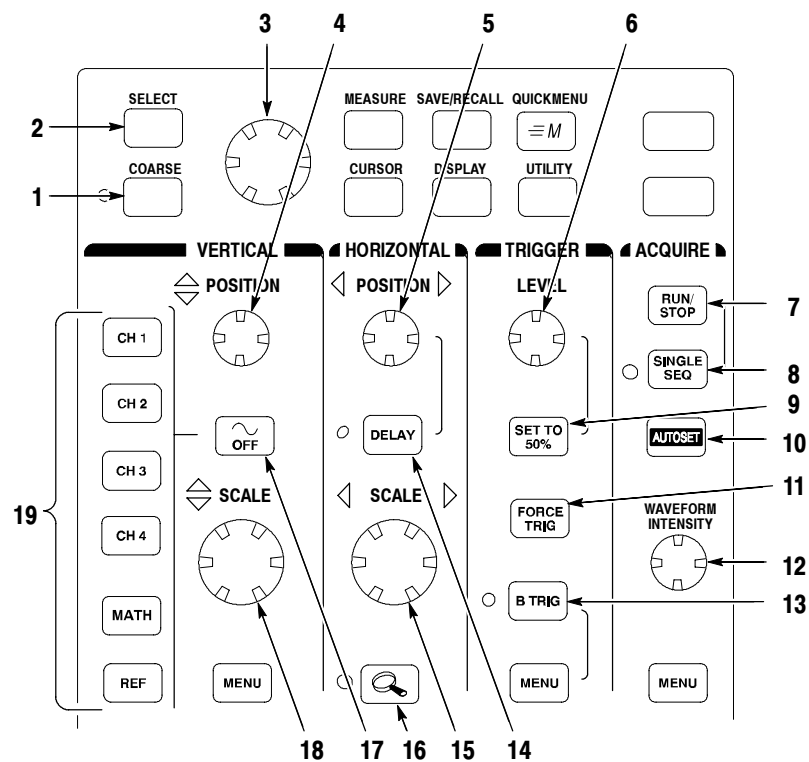

1. COARSE. Causes the general purpose knob and position knobs to make adjustments more quickly.
2. SELECT. Toggles between the two cursors to select the active cursor.
3. General purpose knob. Moves the cursors. Sets numerical parameter values for some menu items. Push COARSE to make adjustments quickly.
4. Vertical POSITION. Adjusts the vertical position of the selected waveform. Push COARSE to make adjustments more quickly.
5. Horizontal POSITION. Adjusts the trigger point location relative to the acquired waveforms. Push COARSE to make adjustments quickly.

- 6.** Trigger LEVEL. Adjusts the trigger level.
- 7.** RUN/STOP. Stops and restarts acquisition.
- 8.** SINGLE SEQ. Sets acquisition, display, and trigger parameters for a single-shot (single-sequence) acquisition.
- 9.** SET TO 50%. Sets the trigger level to the midpoint of the waveform.
- 10.** AUTOSET. Automatically sets the vertical, horizontal, and trigger controls for a usable display.
- 11.** FORCE TRIG. Forces an immediate trigger event.
- 12.** WAVEFORM INTENSITY. Controls waveform intensity.
- 13.** B TRIG. Activates the B trigger. Changes the trigger menu to set the B-trigger parameters.
- 14.** DELAY. Enables delayed acquisition relative to the trigger event. Use horizontal POSITION to set the amount of delay.
- 15.** Horizontal SCALE. Adjusts the horizontal scale factor.
- 16.** Horizontal zoom. Splits the screen and magnifies the current acquisition horizontally.
- 17.** Waveform OFF. Removes the selected waveform from the display.
- 18.** Vertical SCALE. Adjusts the vertical scale factor of the selected waveform.
- 19.** CH1, CH2, (CH3, CH4,) MATH. Displays a waveform and chooses the selected waveform. REF shows the reference waveform menu.

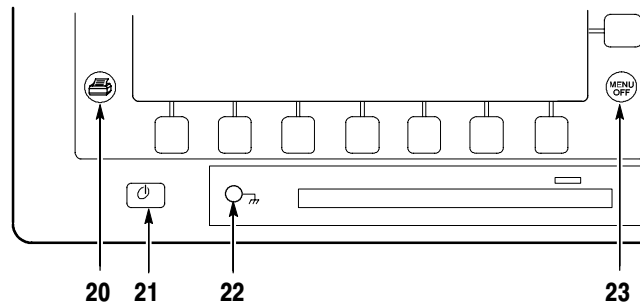

- 20.** Hard copy. Initiates a hard copy using the port selected in the Utility menu.
- 21.** Power switch. Turns power to on or standby.
- 22.** Wrist-strap ground. Use to connect a wrist strap when working with ESD-sensitive circuits. This connector is not a safety ground.
- 23.** MENU OFF. Clears menu from the display.

Identifying Items in the Display

The following items may appear in the display; not all items are visible at any given time. Some readouts move outside the graticule area when menus are turned off.

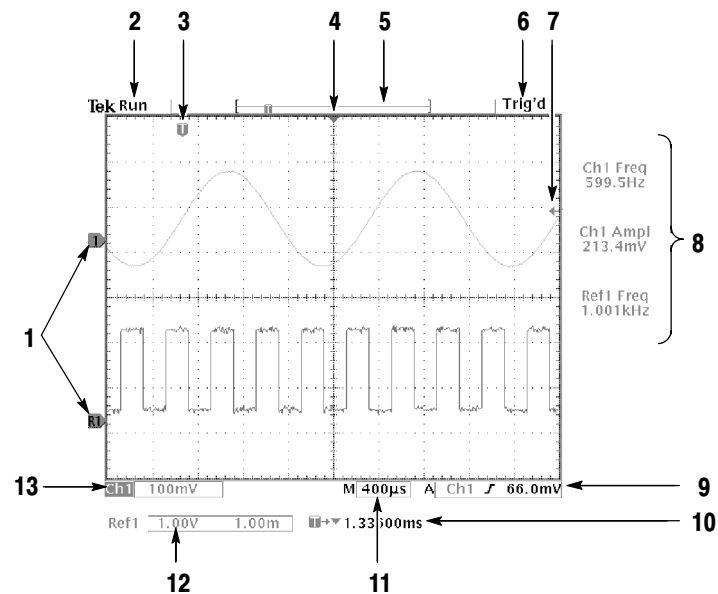

1. Waveform baseline icons show the zero-volt level of the waveforms (ignoring the effect of offset). The icon colors correspond to the waveform colors.
2. Acquisition readout shows when acquisition is running, stopped, or when acquisition preview is in effect.
3. Trigger position icon shows the trigger location in the waveforms.
4. Expansion point icon shows the point that the horizontal scale expands and compresses around.
5. Waveform record icon shows the trigger location relative to the waveform record. The line color corresponds to the selected waveform color.
6. Trigger status readout show trigger status.
7. Trigger level icon shows the trigger level on the waveform. The icon color corresponds to the trigger source channel color.
8. Cursor and measurement readouts show results and messages.
9. Trigger readouts show the trigger sources, slopes, and levels, and position.
10. Readout shows the delay setting or the trigger location within the record.
11. Horizontal readout shows the main or zoom time/division.

- 12. Auxiliary waveform readouts show the vertical and horizontal scale factors of the math or reference waveforms.
- 13. Channel readouts show the channel scale factor, coupling, input resistance, bandwidth limit, and invert status.

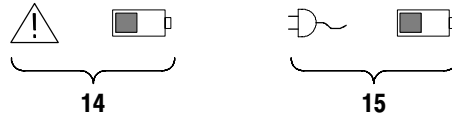

- 14. A triangle icon with the battery icon indicates that a battery is installed and battery power is in use. The battery icon shows the approximate charge level of the battery. See page 2-3 for important safety information.
- 15. A power-plug icon with the battery icon indicates that a battery is installed but line power is in use. The battery icon may be charging. The battery icon shows the approximate charge level.

Using Quick Menus

The QuickMenu feature simplifies the use of the oscilloscope. When you push the QUICKMENU button, a set of frequently used menu functions show on the display. Then, push the screen buttons around the display to operate the QuickMenu.

Using Quick Scope. Quick Scope is one type of QuickMenu that you can use to control the basic oscilloscope functions. You can perform many tasks without using the regular menu system. If you need to use a function that is not contained in the Quick Scope menu, push the button you would normally push to access that function. For example, if you want to add an automatic measurement, push the MEASURE button to set up the measurement. Then, push the QUICKMENU button to return to the Quick Scope menu with the measurement also in the display.

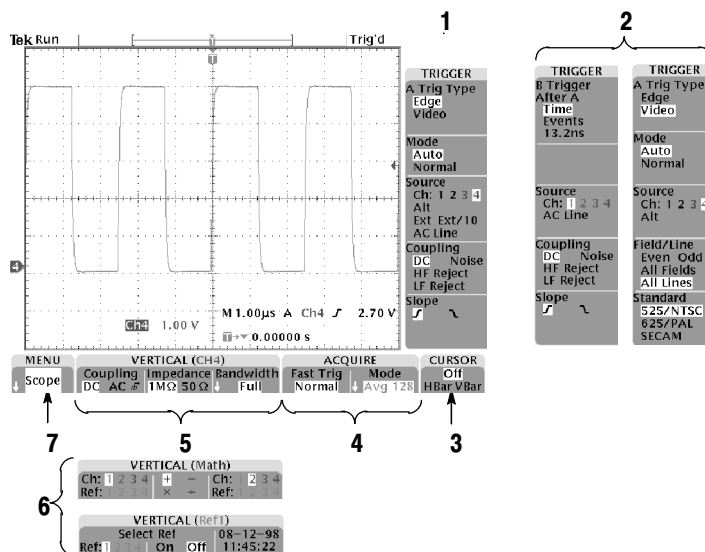

1. Edge Trigger controls. Push these screen buttons to set trigger parameters for edge trigger.
2. Trigger controls if either B trigger or video trigger is selected.
3. Cursor control. Push this screen button to turn on cursors and select the cursor type. Push the SELECT button to toggle between the two cursors to select the active cursor. Use the general purpose knob to move the active cursor.
4. Acquisition controls. Push these screen buttons to set acquisition parameters.
5. Channel vertical controls. Push these screen buttons to set vertical controls for the selected channel. Use the CH1, CH2, CH3, CH4, MATH, and REF buttons to select the channel you want to control.
6. Vertical controls if either the math waveform or a reference waveform is selected.
7. Menu. Push this screen button to select a specific QuickMenu display if more than one is available.

NOTE. Items in the Quick Scope display not mentioned above are also contained in the regular display. Those items are described on page 2-15.

Other QuickMenus. Some optional application packages include a custom QuickMenu display. Those QuickMenus contain specific features that are important for the application.

Front-Panel Connectors

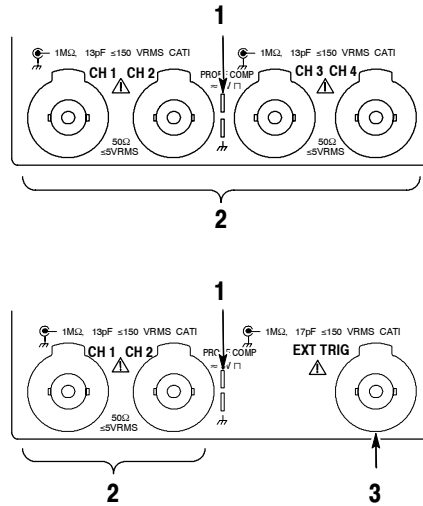

1. PROBE COMP. Square wave signal source to compensate probes.
2. CH1, CH 2, (CH3, CH4). Channel inputs with TekProbe interface.
3. EXT TRIG. External trigger input with TekProbe interface (two-channel models only). Four-channel models have an external trigger input on the rear of the oscilloscope.

Rear-Panel Connectors

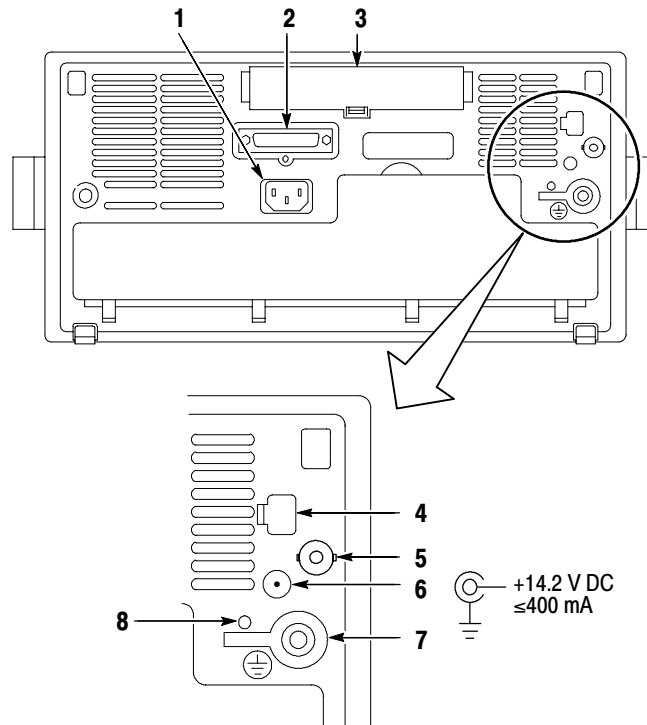

1. Power input. Attach to an AC power line with integral safety ground.
2. Parallel printer port. Connect to a printer to make hard copies.
3. Communication Module compartment. Install optional communication modules or the thermal printer.
4. Ethernet port. Connects the oscilloscope to a 10baseT local area network.
5. External Trigger input (four-channel models only). See the *Specifications* appendix for external trigger signal requirements.
6. DC power output. Provides ~15 V DC power to accessories or to the plug-in TDS3PRT thermal printer.
7. Ground terminal. Connect to earth ground when using battery power. See page 2-3 for important safety information.
8. CAL switch. For use by authorized service personnel only.

Communication Module Connectors

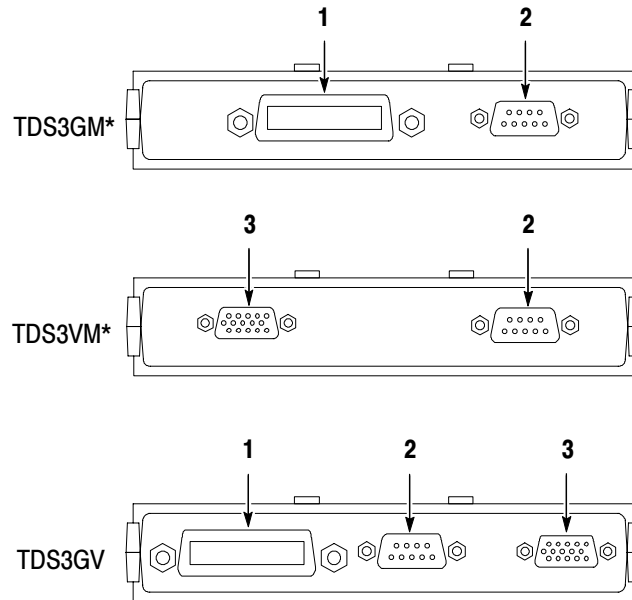

* No longer manufactured, replaced by TDS3GV

1. GPIB port. Connect to a controller for remote programmability.
2. RS-232 port. Connect to a controller or terminal for remote programmability or printing.
3. VGA port. Connect to a VGA monitor to display the screen image.

Probe Compensation

Perform this adjustment to match your probe to the input channel. This should be done whenever you attach a passive probe for the first time to any input channel.

1. Connect the oscilloscope probe to channel 1. Attach the probe tip and reference lead to the **PROBE COMP** connectors, then push **AUTOSET**.

If using the probe hook-tip, ensure a proper connection by firmly twisting the tip onto the probe.

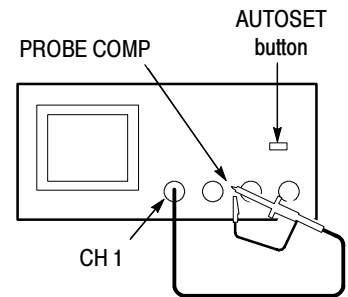

2. Check the shape of the displayed waveform.

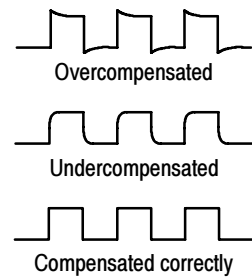

3. If necessary, adjust your probe.

Repeat as necessary.

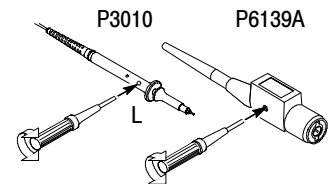

Self Calibration

The self calibration routine lets you quickly optimize the oscilloscope signal path for maximum measurement accuracy. You can run the routine anytime but you should always run the routine if the ambient temperature changes by 10° C or more.

To compensate the signal path, do the following steps:

1. Disconnect any probes or cables from the channel input connectors.
2. Push the **UTILITY** button.
3. Push the **System** screen button to select **Cal**.
4. Push the **Signal Path** screen button.
5. Push **OK Compensate Signal Path**. This procedure takes several minutes to complete.

NOTE. *The signal path compensation does not include calibration to the probe tip.*

Transporting the Oscilloscope

When transporting the oscilloscope, wrap the cord around the handle as shown below. Use the supplied cord retainer if the power plug does not have a molded-in retainer. The oscilloscope front cover has a convenient place to store TDS3000B Series 1/4-size user and reference manuals.

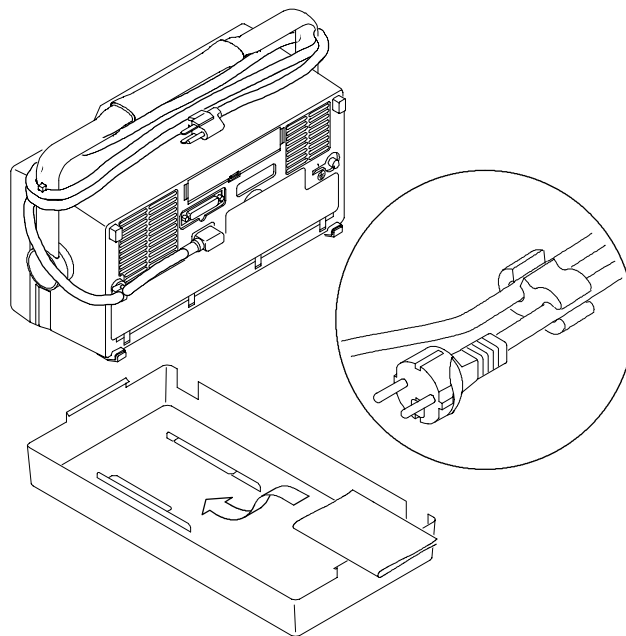

If you are not using a battery, you can use the accessory tray in the battery compartment to store probes and other accessories.



CAUTION. To avoid damage to the disk drive, do not transport the oscilloscope with a floppy disk in the disk drive.

Theory of Operation

This chapter describes the electrical operation of the oscilloscope to the module level. Figure 3-1 shows the oscilloscope module interconnections.

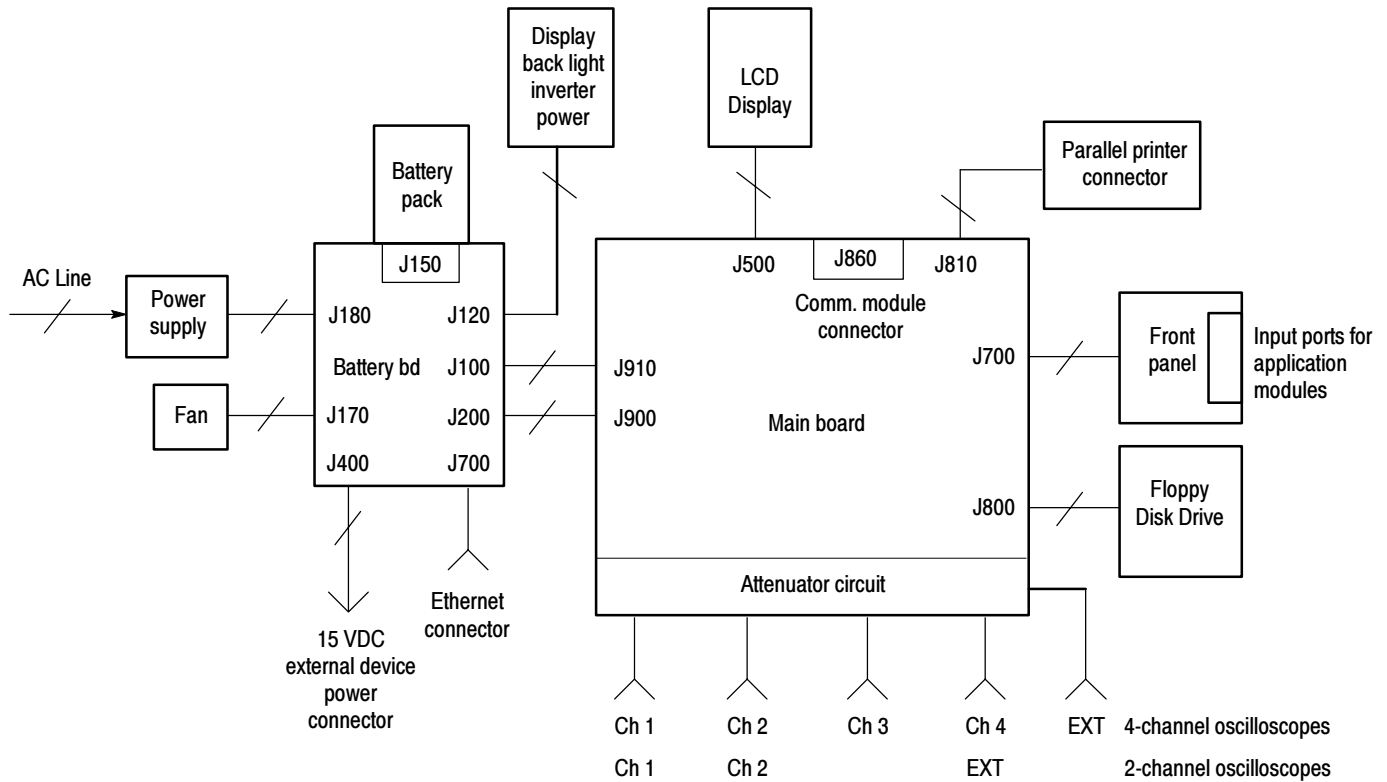

Figure 3-1: TDS3000B series block diagram

Power Supply

The power supply converts AC line voltage to 15 VDC to power all internal circuits and an external power connector. It also supplies power to charge the optional battery pack.

Battery Board

The battery board provides the following functions:

- Interfaces to the optional battery pack (powers the oscilloscope from the battery pack or charges the battery pack when the oscilloscope is connected to AC line).
- Turns on DC power to the oscilloscope.
- Converts 15 VDC from the power supply to 5 VDC for the main and front panel boards and ± 15 VDC for probe power.
- Powers the cooling fan.
- Provides 15 VDC to the external power connector for powering external devices.
- Provides power to the display back light inverter board.
- Provides an Ethernet 10BaseT connector to connect the oscilloscope to a network.

Main Board

The Main Board module contains the following functions.

Acquisition System

The acquisition system begins with the analog signal path and ends with a digitized signal in memory. The signal enters a channel input and then passes through an attenuator and preamplifier. The analog signal from each preamplifier goes through a sampler and digitizer, a time base controller, and then into acquisition memory. The analog signal from each preamplifier is also distributed to a trigger circuit.

Trigger System

The trigger system processes the analog signals from the preamplifiers and sends trigger information to the time base controller. Advanced trigger functions are enabled only when the appropriate application modules and supporting software is installed.

Display System

The display system combines live waveform data from acquisition memory with menus and text and stores this information in display memory. It then uses this data to refresh the VGA display module (LCD).

Processor System The processor system contains a MPC680DC Power PC microprocessor that controls the entire instrument. The processor system also contains FLASH ROM, system RAM, and interfaces to communication modules, the parallel printer port, and the floppy disk drive.

Power Converter The power converter receives 15 VDC (or battery voltage) from the battery board and generates voltages for the analog and digital circuitry on the main board.

Display Module

The display module consists of a color liquid crystal display (LCD), a display driver, a pair of fluorescent back light tubes, and a high-voltage back light power supply.

Front-Panel Board

The front-panel board contains a microprocessor that reads the front-panel buttons and controls and then sends this information to the processor system. The front-panel board also generates the probe compensation output signal and provides an interface to the application modules.

Disk Drive

The disk drive module consists of a 3.5 inch, IBM format, floppy disk drive. The disk drive is controlled by circuitry on the Main Board.

Performance Verification

This chapter contains performance verification procedures for the specifications marked with the ✓ symbol. The following equipment, or a suitable equivalent, is required to complete these procedures.

Description	Minimum requirements	Examples
DC Voltage Source	3 mV to 4 V, $\pm 0.1\%$ accuracy	Wavetek 9500 Oscilloscope Calibrator with two 9510 Output Modules
Leveled Sine Wave Generator	50 kHz to 500 MHz, $\pm 3\%$ amplitude accuracy	
Time Mark Generator	10 ms period, ± 5 ppm accuracy	
50 Ω feedthrough termination	BNC connectors	Tektronix part number 011-0099-00

You may need additional cables and adapters, depending on the actual test equipment you use.

These procedures cover all TDS3000B oscilloscope models. Please disregard checks that do not apply to the specific model you are testing.

Photocopy the test record on the next two pages and use them to record the performance test results for your oscilloscope.

NOTE. Successful completion of the performance verification procedure does not update the instrument Calibration Due date and time. Successful completion of the Adjustment Procedure in Section 5 does automatically update the instrument Calibration Due date and time.

Test Record

Serial number	Procedure performed by	Date

Test	Passed	Failed
Self Test		

Performance checks	Low limit	Test result	High limit
Channel 1 DC measurement accuracy	1 mV/div	99.25 mV	100.8 mV
	2 mV/div	-7.540 mV	-6.460 mV
	5 mV/div	-101.8 mV	-98.24 mV
	50 mV/div	982.4 mV	1.018 V
	50 mV/div	632.4 mV	667.6 mV
	50 mV delta	340.5 mV	359.5 mV
	90 mV/div	-339.3 mV	-290.7 mV
	200 mV/div	9.900 V	10.10 V
	1 V/div	-10.30 V	-9.698 V
Channel 2 DC measurement accuracy	1 mV/div	99.25 mV	100.8 mV
	2 mV/div	-7.540 mV	-6.460 mV
	5 mV/div	-101.8 mV	-98.24 mV
	50 mV/div	982.4 mV	1.018 V
	50 mV/div	632.4 mV	667.6 mV
	50 mV delta	340.5 mV	359.5 mV
	90 mV/div	-339.3 mV	-290.7 mV
	200 mV/div	9.900 V	10.10 V
	1 V/div	-10.30 V	-9.698 V

Performance checks		Low limit	Test result	High limit
Channel 3 DC measurement accuracy	1 mV/div	99.25 mV		100.8 mV
	2 mV/div	-7.540 mV		-6.460 mV
	5 mV/div	-101.8 mV		-98.24 mV
	50 mV/div	982.4 mV		1.018 V
	50 mV/div	632.4 mV		667.6 mV
	50 mV delta	340.5 mV		359.5 mV
	90 mV/div	-339.3 mV		-290.7 mV
	200 mV/div	9.900 V		10.10 V
	1 V/div	-10.30 V		-9.698 V
Channel 4 DC measurement accuracy	1 mV/div	99.25 mV		100.8 mV
	2 mV/div	-7.540 mV		-6.460 mV
	5 mV/div	-101.8 mV		-98.24 mV
	50 mV/div	982.4 mV		1.018 V
	50 mV/div	632.4 mV		667.6 mV
	50 mV delta	340.5 mV		359.5 mV
	90 mV/div	-339.3 mV		-290.7 mV
	200 mV/div	9.900 V		10.10 V
	1 V/div	-10.30 V		-9.698 V
Channel 1 bandwidth		425 mV		—
Channel 2 bandwidth		425 mV		—
Channel 3 bandwidth		425 mV		—
Channel 4 bandwidth		425 mV		—
Channel 1 trigger sensitivity	rising slope	stable trigger		—
	falling slope	stable trigger		—
Channel 2 trigger sensitivity	rising slope	stable trigger		—
	falling slope	stable trigger		—
Channel 3 trigger sensitivity	rising slope	stable trigger		—
	falling slope	stable trigger		—
Channel 4 trigger sensitivity	rising slope	stable trigger		—
	falling slope	stable trigger		—
Sample rate and delay time accuracy		-2 divisions		+2 divisions

Performance Verification Procedures

The following three conditions must be met prior to doing these procedures:

1. The oscilloscope must have been operating continuously for twenty (20) minutes in an environment that meets the operating range specifications for temperature and humidity.
2. You must perform the Compensate Signal Path operation described on page 2-22. If the operating temperature changes by more than 10° C, you must perform the Compensate Signal Path operation again.
3. You must connect the oscilloscope and the test equipment to the same AC power circuit. Connect the oscilloscope and test instruments into a common power strip if you are unsure of the AC power circuit distribution. Connecting the oscilloscope and test instruments into separate AC power circuits can result in offset voltages between the equipment, which can invalidate the performance verification procedure.

The time required to complete the entire procedure is approximately one hour.



WARNING. *Some procedures use hazardous voltages. To prevent electrical shock, always set voltage source outputs to 0 V before making or changing any interconnections.*

Self Test

This procedure uses internal routines to verify that the oscilloscope functions and passes its internal self tests. No test equipment or hookups are required. Start the self test with these steps:

1. Disconnect all probes and cables from the oscilloscope inputs.
2. Push the **UTILITY** menu button.
3. Push the **System** screen button to select **Diags**.
4. Push the **Loop** screen button and choose **Once**.
5. Push the **Execute** screen button.
6. Push the **OK Confirm Run Test** screen button.

A dialog box displays the result when the self test completes. Push the **MENU OFF** screen button to continue operation.

Check DC Voltage Measurement Accuracy

This test checks the DC voltage measurement accuracy in the average acquisition mode.

1. Set the DC voltage source output level to **0 V**.
2. Connect the DC voltage source to the oscilloscope channel 1 input as shown below. Push the channel 1 selection button (**CH 1**).

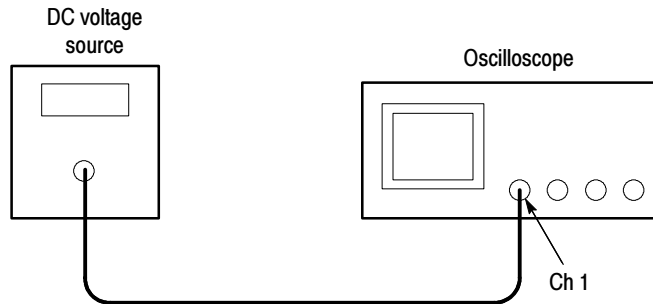

3. Push the **SAVE/RECALL** menu button.
4. Push the **Recall Factory Setup** screen button and then push the **OK Confirm Factory Init** screen button.
5. Push the acquire **MENU** button.
6. Push the **Mode** screen button and then push the **Average** screen button.
7. Adjust the number of averages to **16** with the general purpose knob.
8. Go to step 11.
9. Move the DC voltage source output cable to the oscilloscope channel you want to check.
10. Push the channel button (**CH 1**, **CH 2**, **CH 3**, or **CH 4**) for the channel you want to check.
11. Push the **MEASURE** menu button.
12. Push the **Select Measurement** screen button.
13. Push the **- more -** screen button until you can select the **Mean** measurement.
14. Push the vertical **MENU** button.

Vertical SCALE setting	Invert setting	Bandwidth limit setting	Offset	Input voltage	Low limit	High limit
1 mV/div	Off	20 MHz	96.5 mV	100 mV	99.25 mV	100.8 mV
2 mV/div	Off	20 MHz	0.0 V	-7 mV	-7.540 mV	-6.460 mV
5 mV/div	Off	20 MHz	-82.5 mV	-100 mV	-101.8 mV	-98.24 mV
50 mV/div	Off	Full	825 mV ¹	1.0 V	982.4 mV	1.018 V
50 mV/div	Off	Full	825 mV ¹	650 mV	632.4 mV	667.6 mV
50 mV delta ²					340.5 mV	359.5 mV
90 mV/div ³	Off	Full	0.0 V	-315 mV	-339.3 mV	-290.7 mV
200 mV/div	Off	150 MHz ⁴	9.3 V	10 V	9.900 V	10.10 V
1 V/div	On ⁵	150 MHz ⁴	-6.5 V	10 V	-10.30 V	-9.698 V

¹ Set the vertical offset to 0 V before adjusting the vertical offset to 825 mV.

² Refer to step 15e on page 4-6 to calculate 50 mV delta measurement.

³ Push the Vertical MENU button, push the Fine Scale screen button, then use the general purpose knob to adjust the setting to 90 mV/div.

⁴ Use the Full bandwidth setting on the TDS3012B or TDS3014B oscilloscopes.

⁵ Make sure to turn Invert setting to On for this measurement.

15. For each row of the table, do these steps:

- a. Set the vertical **SCALE** control to the setting in the table.
- b. Set the **Invert** and **Bandwidth Limit** controls to the settings in the table.
- c. Set the output of the DC voltage source to the voltage level in the table.
- d. Verify that the oscilloscope **Mean** measurement is within the limits listed in the above table.
- e. For the 50 mV delta measurement, subtract the second 50 mV measurement from the first 50 mV measurement; verify that the difference is within the limits stated in the Delta row of the table.

16. Repeat steps 15a through 15e for each row in the table.

17. Push the waveform off  button.

18. Repeat steps 9 through 17 for each channel of the oscilloscope (not including the external trigger input on some models).

Check Bandwidth

This test checks the bandwidth for each channel.

1. Connect the output of the leveled sine wave generator to the oscilloscope channel 1 input as shown below.

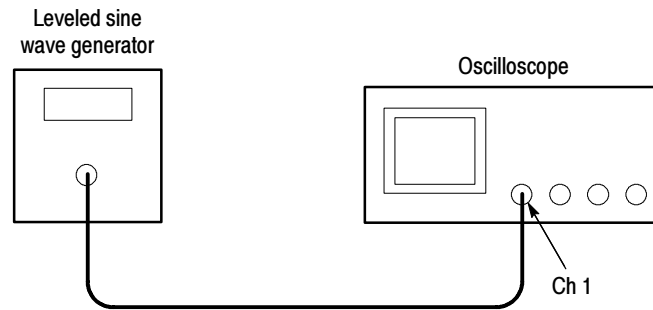

2. Push the **SAVE/RECALL** menu button.
3. Push the **Recall Factory Setup** screen button and then push the **OK Confirm Factory Init** screen button.
4. Push the acquire **MENU** button.
5. Push the **Mode** screen button and then push the **Average** screen button.
6. Adjust the number of averages to **16** with the general purpose knob.
7. Push the trigger **MENU** button.
8. Push the **Source** screen button and then push the **Vert** screen button.
9. Push the **Coupling** screen button and then push the **Noise Reject** screen button.
10. Go to step 13.
11. Move the output cable of the leveled sine wave generator to the oscilloscope channel you want to check.
12. Push the channel button (**CH 1**, **CH 2**, **CH 3**, or **CH 4**) for the channel you want to check.
13. Set the horizontal **SCALE** to **10 μ s/div**.
14. Push the vertical **MENU** button.
15. Push the **Coupling** screen button and select **50 Ω** input resistance.
16. Push the **MEASURE** menu button.
17. Push the **Select Measurement** screen button.

18. Push the **- more -** screen button until you can select the **Pk-Pk** measurement.
19. Set the vertical **SCALE** to **100 mV/div**.
20. Set the output frequency of the leveled sine wave generator to **50 kHz**.
21. Set the output amplitude of the leveled sine wave generator so the peak-to-peak measurement is between **599 mV** and **601 mV**.
22. Set the horizontal **SCALE** to **10 ns/div**.
23. Set the output frequency of the leveled sine wave generator to the frequency shown in the table below.

Oscilloscope model	Frequency
TDS3012B, TDS3014B	100 MHz
TDS3032B, TDS3034B	300 MHz
TDS3052B, TDS3054B	500 MHz

24. Verify that the peak-to-peak measurement is ≥ 425 mV.
25. Push the waveform off  button.
26. Repeat steps 11 through 25 for each channel of the oscilloscope (not including the external trigger input on some models).

Check Channel Edge-Trigger Sensitivity

This test checks the edge-trigger sensitivity for each channel.

1. Connect the output of the leveled sine wave generator to the oscilloscope channel 1 input as shown below.

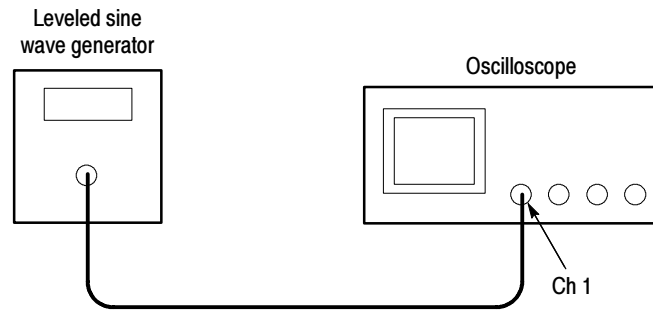

2. Push the **SAVE/RECALL** menu button.
3. Push the **Recall Factory Setup** screen button and then push the **OK Confirm Factory Init** screen button.
4. Push the acquire **MENU** button.
5. Push the **Mode** screen button and then push the **Average** screen button.
6. Adjust the number of averages to **16** with the general purpose knob.
7. Push the trigger **MENU** button.
8. Push the **Source** screen button and then push the **Vert** screen button.
9. Set the horizontal **SCALE** to **10 ns/div**.
10. Go to step 13.
11. Move the output cable of the leveled sine wave generator to the oscilloscope channel you want to check.
12. Push the channel button (**CH 1**, **CH 2**, **CH 3**, or **CH 4**) for the channel you want to check.
13. Push the vertical **MENU** button.
14. Push the **Coupling** screen button and select **50 Ω** input resistance.
15. Push the **MEASURE** menu button.
16. Push the **Select Measurement** screen button.
17. Push the **- more -** screen button until you can select the **Pk-Pk** measurement.
18. Set the vertical **SCALE** to **500 mV/div**.

19. Set the output frequency of the leveled sine wave generator to the frequency shown in the table below.

Oscilloscope model	Frequency
TDS3012B, TDS3014B	100 MHz
TDS3032B, TDS3034B	300 MHz
TDS3052B, TDS3054B	500 MHz

20. Set the output amplitude of the leveled sine wave generator so the peak-to-peak measurement is approximately **500 mV**.
21. Push the **SET TO 50%** button. Adjust the trigger **LEVEL** as necessary and then verify that triggering is stable.
22. Push the trigger **MENU** button.
23. Push the **Slope** screen button and select the \ (**falling**) slope.
24. Push the **SET TO 50%** button. Adjust the trigger **LEVEL** as necessary and then verify that triggering is stable.
25. Push the **Slope** screen button and select the / (**rising**) slope.
26. Push the waveform off  button.
27. Repeat steps 11 through 26 for each channel of the oscilloscope (not including the external trigger input on some models).

Check Sample Rate and Delay Time Accuracy

This test checks the time base accuracy.

1. Connect the output of the time mark wave generator to the oscilloscope channel 1 input as shown below.

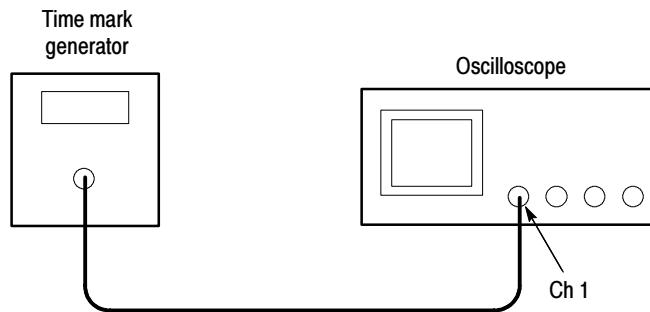

2. Push the **SAVE/RECALL** menu button.
3. Push the **Recall Factory Setup** screen button and then push the **OK Confirm Factory Init** screen button.
4. Push the **DELAY** button to turn delay off.
5. Push the vertical **MENU** button.
6. Push the **Coupling** screen button and select **50 Ω** input resistance.
7. Set the time mark generator period to **100 ms**. Use a time mark waveform with a fast rising edge.
8. If adjustable, set the time mark amplitude to approximately **1 V_{p-p}**.
9. Set the vertical **SCALE** to **500 mV/div**.
10. Set the horizontal **SCALE** to **20 ms/div**.
11. Adjust the vertical **POSITION** control to center the time mark signal on the screen.
12. Adjust the trigger **LEVEL** as necessary to obtain a triggered display.
13. Adjust the horizontal **POSITION** control to move the trigger location to the center of the screen (**50%**).
14. Push the **DELAY** button to turn delay on.

15. Turn the horizontal **POSITION** control counter-clockwise to set the delay to exactly **100 ms**.
16. Set the horizontal scale to **1 μ s/div**.
17. Check that the rising edge of the marker crosses the center horizontal graticule line within ± 2 divisions of center graticule.

NOTE. *One division of displacement from graticule center corresponds to a 10 ppm time base error.*

This completes the performance verification procedure.

Adjustment Procedures

This chapter contains the factory adjustment procedures for the TDS3000B series oscilloscopes. Only qualified personnel should perform adjustment procedures. Read the *Service Safety Summary* and the *General Safety Summary* before performing any service procedures. Also refer to the chapter *Operating Information* for information about using the oscilloscope.

NOTE. *The voltage references inside the oscilloscope are very stable over time and should not require routine adjustment. Before performing any procedure in this chapter, do the Performance Verification procedures (Section 4) to check whether or not the oscilloscope meets specifications.*

Successful completion of this adjustment procedure automatically updates the instrument Calibration Due date and time. Successful completion of the Performance Verification procedure in Section 4 does not update the instrument Calibration Due date and time.

Required Equipment

The following equipment, or a suitable equivalent, is required to complete these procedures.

Description	Minimum requirements	Example
DC voltage source	50 mV to 70 V, $\pm 0.1\%$ amplitude accuracy	Wavetek 9500 Oscilloscope Calibrator with one 9510 Output Module
Leveled sine wave generator	30 kHz to 80 MHz, 100 ppm frequency accuracy, 3% amplitude accuracy	
Fast-rise generator	100 Hz - 1 MHz repetition rate, 2.2 V Pk-Pk signal (-2.2 V to 0 V) unloaded signal, ≤ 1 ns rise time	
50 Ω BNC cable (five required ¹)	BNC male to BNC male, ≈ 10 in (25 cm) long	Tektronix part number 012-0208-00
BNC T (three required ¹)	One male and two female BNC connectors	Tektronix part number 103-0030-00

Description	Minimum requirements	Example
BNC female-to-female adapter	Two female BNC connectors	Tektronix part number 103-0028-00
Adjustment tool	Non conducting shaft with diameter ≤ 2.5 mm (≤ 0.1 in)	Tektronix part number 003-1433-00

¹ **The number required is reduced by two if you are adjusting a two-channel oscilloscope.**

Overview of the Adjustment Process

The oscilloscope is protected from inadvertently changing factory adjustments by a rear-panel switch. To perform the factory adjustment, you must push and hold the switch while you power on the oscilloscope.

Before performing adjustment procedures, you must warm up the oscilloscope at least ten minutes in an ambient temperature between 20° C and 30° C. Adjustments performed prior to warm-up or outside this temperature range may result in poor performance. You must also recall the default factory settings before starting the factory adjustment procedure.

The factory adjustment procedure consists of a series of steps; as you move through these steps, the oscilloscope display provides instructions that describe the specific input signal requirements for each step. If the step passes, the oscilloscope moves on to the next step. If any step fails, you can repeat the step or choose to abort the procedure.

NOTE. *Do not turn any knobs or push any front-panel buttons other than the Next Step or Previous Step buttons during the adjustment procedure. Doing so will cause the oscilloscope to abort the adjustment procedure. The oscilloscope uses the previous calibration constants if the adjustment procedure is aborted.*

The screen does not display the actual oscilloscope settings (such as channel input impedance, vertical and horizontal settings, and so on) during the adjustment procedure. The oscilloscope automatically sets the instrument settings, but these settings may not read out correctly on the display.

During some steps, the instrument may appear to be idle for several minutes while it is processing information internally. Please have patience.

If all steps in the procedure are completed successfully, a “Pass” message is displayed and the new calibration constants take affect. If the procedure fails for any reason, the oscilloscope reverts to the previous calibration settings.

Signal Connections

The adjustment procedure requires three types of equipment setups if you are adjusting a four-channel oscilloscope, or four types if you are adjusting a two-channel oscilloscope. For each step of the procedure, the oscilloscope display indicates which setup is the correct one to use. The equipment setups are described below.

Applying DC Voltage to Input Channels

The first adjustment procedures require a DC voltage (or zero volts) applied simultaneously to all instrument channels. A typical on-screen instruction might read:

Apply 0.0000 V DC signal to all channels.

When you see an instruction similar to this, connect the oscilloscope to the DC voltage source to all the channels as shown below and then set the DC voltage to the specified value.

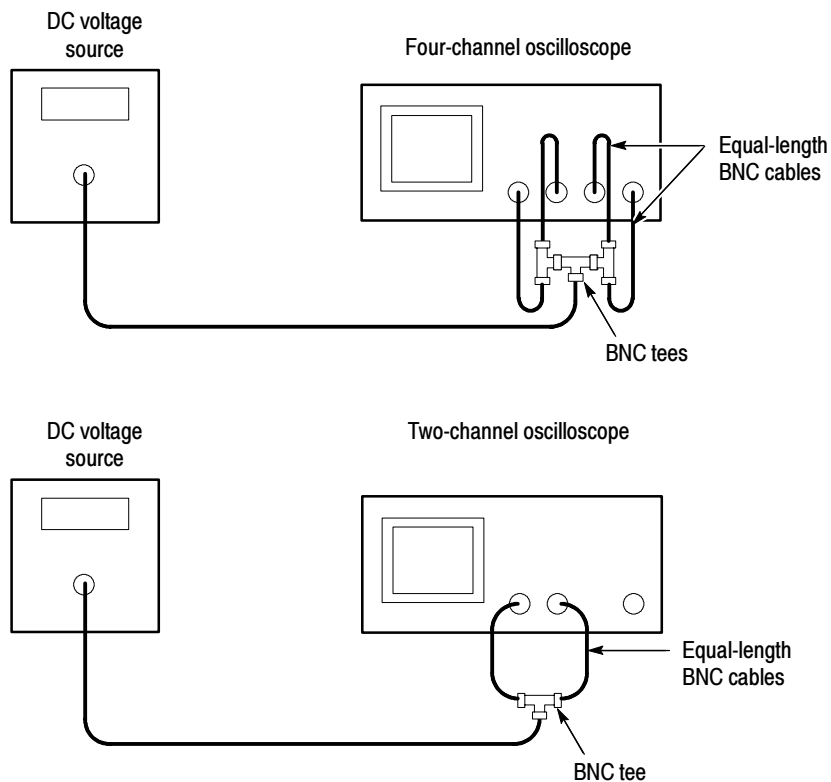

NOTE. If the DC voltage source you are using has an output head, use a female-to-female BNC adapter and a short BNC cable to make the connection to the first BNC tee.

A number of steps require setting the input voltage to 0.0000 V. Some calibration equipment can inject a small amount of noise or have a very low-level AC signal near ground. This can result in failure of the performance verification procedure even though the instrument passes the factory adjustment procedure. If you think that your calibration equipment injects noise or AC at zero volts, make sure to disconnect signal cables from the oscilloscope for all steps that require 0.000 V input.

Applying AC Voltage to a Channel

Later in the procedure, a leveled sine wave needs to be applied to each channel, one channel at a time. A typical on-screen instruction might read:

Apply 400.00 mV Pk-Pk 80 MHz sine wave signal to channel 1 only.

When you see an instruction similar to this, connect the leveled sine wave generator to the specified channel and then set the amplitude and frequency to the specified values.

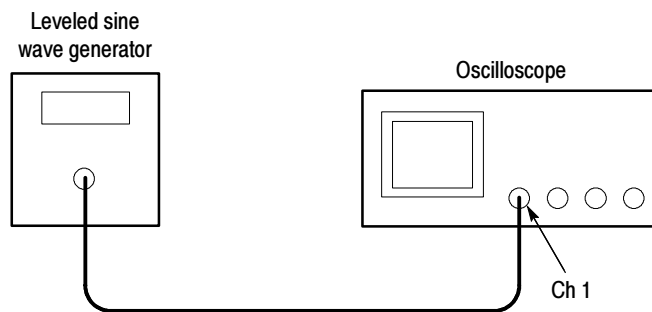

NOTE. If the leveled sine wave generator you are using has an output head, connect the head directly to the channel input.

Make sure that the AC generator output is set for a 50-ohm load for all AC-source steps.

Applying Fast Rise Step Signals to all Channels

During the procedure a fast rise step signal needs to be applied simultaneously to all channels. A typical on-screen instruction might read:

Apply -2.2 V to 0 V (unloaded), fast-rise signal (≤ 1 ns) to all channels.

Use the *Applying DC Voltage to Input Channels* equipment setup shown on page 5-3.

NOTE. Make sure to set the generator source impedance to 50 ohms.

Set the fast-rise signal repetition rate to anywhere between 100 Hz and 1 MHz, inclusive.

The fast-rise signal Pk-Pk range is -2.2 V to 0 V (unloaded). Measure the fast-rise signal, using an independent device with an input termination set to 1 M Ω or greater, to verify that the fast-rise signal does vary between -2.2 V and 0 V, regardless of the generator's programmed value. This ensures that there is enough signal range to adjust either 2-channel or 4-channel oscilloscopes.

Make sure that the coax cable connection path length is the same for all channels.

Applying DC Voltage to the External Trigger

If you are adjusting a two-channel oscilloscope, a DC voltage needs to be applied to the external trigger input. A typical on-screen instruction might read:

Apply -5.00 V DC signal to external trigger input.

When you see an instruction similar to this, connect the oscilloscope to the DC voltage source and set the DC voltage to the specified value.

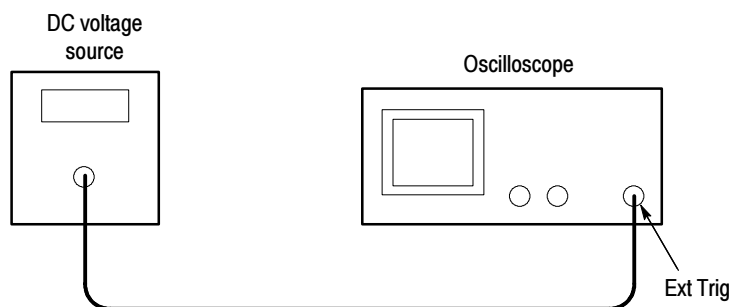

NOTE. If the DC voltage source you are using has an output head, connect the head directly to the external trigger input.

Factory Adjustment Procedure

To perform the factory adjustment procedure, do these steps:

1. Connect the oscilloscope to an AC power source.

NOTE. You must connect the oscilloscope and the test equipment to the same AC power circuit. Connect the oscilloscope and test instruments into a common power strip if you are unsure of the AC power circuit distribution. Connecting the oscilloscope and test instruments into separate AC power circuits can result in offset voltages between the equipment, which can invalidate the adjustment procedure.

2. Locate the hole that provides access to the CAL switch on the rear panel.

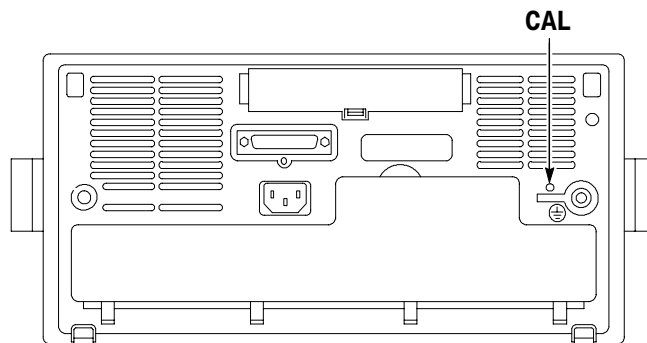

3. Put the adjustment tool into the CAL switch hole. Push and hold the CAL switch in while you power on the oscilloscope. Release the switch when the oscilloscope shows the power-on message with the oscilloscope graticule in the background.
4. Push the **SAVE/RECALL** button.
5. Push the **Recall Factory Setup** screen button.
6. Push the **OK Confirm Factory Init** screen button to restore factory settings prior to doing the factory calibration.

NOTE. Do not skip the Recall Factory Setup steps. You must recall the factory settings in order to correctly start the factory adjustment procedure.

7. Push the **MENU OFF** button.

8. Push the **UTILITY** button.
9. Push the **System** screen button to select **Cal**.
10. Push the **Factory** screen button.
11. Push the **OK Do Factory Calibration** screen button to start the adjustment process.
12. Connect signals from the DC voltage source, leveled sine wave, or fast-rise generator as instructed by the oscilloscope display. After you connect the correct signal, push the **OK Do Next Step** screen button to continue the process.

NOTE. *The oscilloscope adjusts itself automatically using the reference signal from the DC voltage source, leveled sine wave, or fast-rise generator. There are no manual oscilloscope adjustments that you need to make.*

*If you make an error, such as connecting the wrong input signal, you can repeat the last step by pushing the **Return to Previous Screen** screen button.*

13. Continue the adjustment process until it is complete. You can abort the process at any time by pushing the **MENU OFF** button or by changing to a different menu.
14. Do the performance verification tests (Section 4) to verify that the adjustment procedure has correctly calibrated the oscilloscope. Incorrect use of calibration equipment can cause the oscilloscope to pass the adjustment procedure but fail performance verification. Refer to the note on page 5-4 regarding possible injected noise for 0.000V DC input levels.

Maintenance

This chapter contains the information needed to do periodic and corrective maintenance on the oscilloscope. The following sections are included:

- *Preparation* refers you to important information contained elsewhere in this manual.
- *Preventing ESD* provides general information on preventing damage to internal modules when doing maintenance.
- *Inspection and Cleaning* provides procedures for inspecting the oscilloscope and cleaning its external and internal modules.
- *Removal and Installation Procedures* provide procedures for the removal and installation of modules.
- *Troubleshooting* provides information for isolating failed modules.
- *Unpacking and Repacking Instructions* provides packaging information for shipment or storage.

Preparation

Only qualified personnel should perform service procedures. Read the *Service Safety Summary* and the *General Safety Summary* before performing any service procedures. Also refer to the chapter *Operating Information* for information about using the oscilloscope.

Preventing ESD

When performing any service which requires internal access to the oscilloscope, adhere to the following precautions to avoid damaging internal modules and their components due to electrostatic discharge (ESD).



CAUTION. *Static discharge can damage any semiconductor component in this instrument.*

1. Minimize handling of static-sensitive modules.
2. Transport and store static-sensitive modules in their static protected containers or on a metal rail. Label any package that contains static-sensitive modules.

3. Discharge the static voltage from your body by wearing a grounded antistatic wrist strap while handling these modules. Do service of static-sensitive modules only at a static-free work station.
4. Nothing capable of generating or holding a static charge should be allowed on the work station surface.
5. Handle circuit boards by the edges when possible.
6. Do not slide the modules over any surface.
7. Avoid handling modules in areas that have a floor or work-surface covering capable of generating a static charge.

Inspection and Cleaning

This section describes how to inspect for dirt and damage, and how to clean the oscilloscope. Inspection and cleaning are done as preventive maintenance. Preventive maintenance, when done regularly, may prevent malfunctions and enhance reliability.

Preventive maintenance consists of visually inspecting and cleaning the oscilloscope, and using general care when operating it. How often to do maintenance depends on the severity of the environment in which the oscilloscope is used. A proper time to perform preventive maintenance is just before adjustment of the oscilloscope.

General Care

Protect the oscilloscope from adverse weather conditions. The oscilloscope is not waterproof.

Do not store or leave the oscilloscope where the LCD display will be exposed to direct sunlight for long periods of time.



CAUTION. To avoid damage to the oscilloscope, do not expose it to any sprays, liquids, or solvents.

Inspection and Cleaning Procedures

Inspect and clean the oscilloscope as often as operating conditions require. The collection of dirt on internal components can cause them to overheat and breakdown. Dirt acts as an insulating blanket, preventing efficient heat dissipation. Dirt also provides an electrical conduction path that could cause an oscilloscope failure, especially under high-humidity conditions.

Inspection — Exterior. Inspect the outside of the oscilloscope for damage, wear, and missing parts. An oscilloscope that appears to have been dropped or otherwise abused should be checked thoroughly to verify correct operation and performance. Immediately repair defects that could cause personal injury or lead to further damage to the oscilloscope.

Cleaning Procedure — Exterior. To clean the oscilloscope exterior, perform the following steps:

1. Remove loose dust on the outside of the oscilloscope with a lint free cloth. Use care to avoid scratching the clear plastic display filter.
2. Use a soft cloth or paper towel dampened with water to clean the oscilloscope. You can use a 75% isopropyl alcohol solution for more efficient cleaning.



CAUTION. To avoid damage to the surface of the oscilloscope, do not use any abrasive or chemical cleaning agents.

Inspection — Interior. During normal use, the oscilloscope case protects the internal components against common dust and dirt. However, if it appears that the oscilloscope may have been damaged or has been exposed to an unusually dirty or wet environment, you should inspect and clean the interior.

To inspect and clean the interior, disassemble the oscilloscope according to the procedure *Removal and Installation Procedures* on page 6-5.

Inspect the internal portions of the oscilloscope for damage and wear using Table 6-1 as a guide. Defects found should be repaired immediately.

Table 6-1: Internal inspection check list

Item	Inspect for	Repair action
Front and Rear Case Cover	Cracks or deformations. Broken doors or hinges. Loose labels.	Repair or replace defective hardware.
Metal chassis pieces	Bent, fractured, or broken pieces.	Repair or replace defective hardware.
Circuit boards	Loose, broken, or corroded solder connections. Burned circuit boards. Burned, broken, or cracked circuit-run plating.	Remove failed module and replace with a new module.

Table 6- 1: Internal inspection check list (Cont.)

Item	Inspect for	Repair action
Solder connections	Cold solder or rosin joints.	Resolder joint and clean with isopropyl alcohol.
Wiring and cables	Loose plugs or connectors. Burned, broken, or frayed wiring.	Firmly seat connectors. Repair or replace modules with defective wires or cables.

Cleaning Procedure — Interior. To clean the oscilloscope interior, perform the following steps:

1. Blow off dust with dry, low-pressure, deionized air (approximately 9 psi).
2. Remove any remaining dust with a lint-free cloth dampened in isopropyl alcohol (75% solution) and rinse with warm deionized water. (A cotton-tipped applicator is useful for cleaning in narrow spaces and on circuit boards.)

STOP. *If, after performing steps 1 and 2, a module is clean upon inspection, skip steps 3 and 4. Proceed with step 5.*

If steps 1 and 2 do not remove all the dust or dirt, all modules in the oscilloscope except the Display Module, Fan, and Disk Drive may be spray washed using a solution of 75% isopropyl alcohol. Proceed with step 3.

3. Spray wash dirty parts with the 75% isopropyl alcohol solution and wait 60 seconds for the majority of the alcohol to evaporate.
4. Use hot (49° C to 60° C / 120° F to 140° F) deionized water to thoroughly rinse the parts.
5. Dry all parts with low-pressure, deionized air.
6. Dry all components and assemblies in an oven or drying compartment using low-temperature (52° C to 66° C / 125° F to 150° F) circulating air.

Lubrication. There is no periodic lubrication required for the oscilloscope.

Removal and Installation Procedures

This section describes how to remove and install the major mechanical and electrical modules. It provides the following information:

- *List of Modules* on page 6-5 describes where to locate a list of replaceable modules.
- *Summary of Procedures* on page 6-6 lists the procedures for removal and installation of modules.
- *Tools Required* on page 6-7 describes the tools needed to perform the procedures.
- *Handle*, on page 6-8, begins a series of procedures that describe the removal and installation of modules.

Preparation

Please read the following warning statement. Then read the following general instructions before removing a module.



WARNING. *Only qualified personnel should perform service procedures. Before doing this or any other procedure in this manual, read the General Safety Summary and Service Safety Summary located at the beginning of this manual. Also, to prevent possible injury to service personnel or damage to electrical components, read Preventing ESD on page ix.*

1. Read the *Summary of Procedures* on page 6-6 to understand which procedure to use to access a given module. Then read *Tools Required* on page 6-7 for a list of tools needed to remove and install modules in the oscilloscope.
2. If you are disassembling the oscilloscope for cleaning, refer to the *Inspection and Cleaning* procedure on page 6-2 for cleaning instructions.
3. Remove the optional battery pack and/or communication module before disassembling the oscilloscope.

List of Modules

The *Mechanical Parts List* chapter provides a list of all replaceable modules. Any electrical or mechanical module, assembly, or part listed in the parts list is referred to as a module.

Summary of Procedures

Table 6-2 lists the removal and installation procedures in order of increasing complexity. Within each procedure, only perform the steps that are required to access the modules that need repair.

Table 6-2: Removal and installation procedures

Procedure	Modules accessed	Begins on page
Handle	Handle Hub cover Hub assembly	6-8
Rear case	Rear case Communication module cover Communication module guide Feet Disk drive	6-11
Rear chassis	Rear chassis Battery board Power supply Power supply bracket Line filter DC power cable AC line power cable Fan Parallel printer port External power jack	6-15
Main board	Main board Display cable Disk drive cable	6-22
Front chassis and display Module	Front chassis Display module Inverter cable Inverter board Display module	6-27
Display Inverter board and backlights	Inverter board Backlight tubes	6-30
Front panel	Knobs Front-panel board Flex circuit keypad contacts Keypads	6-35

Tools Required

You will need the following tools to remove and replace all the modules in the oscilloscope.

- Torque-limiting screwdriver, 12 in · lb (1.3 N · m) range with Torx® T-10 and T-15 tips (If you are using a magnetic screwdriver with interchangeable bits, the T-15 bit must be a long bit, at least 5 cm (2 in) overall length).
- Screwdriver with $\frac{1}{8}$ inch flat blade
- $\frac{3}{16}$ inch nut driver
- Needle-nose pliers

Handle You will need a $\frac{1}{8}$ inch flat-bladed screwdriver to remove the handle.

Removal. Use this procedure to remove the handle.

1. Use the $\frac{1}{8}$ inch flat-bladed screwdriver to pry the hub cover off of each side of the handle.
2. Rotate the handle to its full upright position.
3. Locate the handle hub on the display side of the oscilloscope.

NOTE. Do not remove the screw at the center of the handle hub.

4. See Figure 6-1. Use the needle-nose pliers to pull the metal pin in the display-side hub outward approximately 6 mm (0.25 in). If you accidentally pull the metal pin all the way out, reinsert it half way. The pin may be positioned at either the top or bottom of the hub assembly

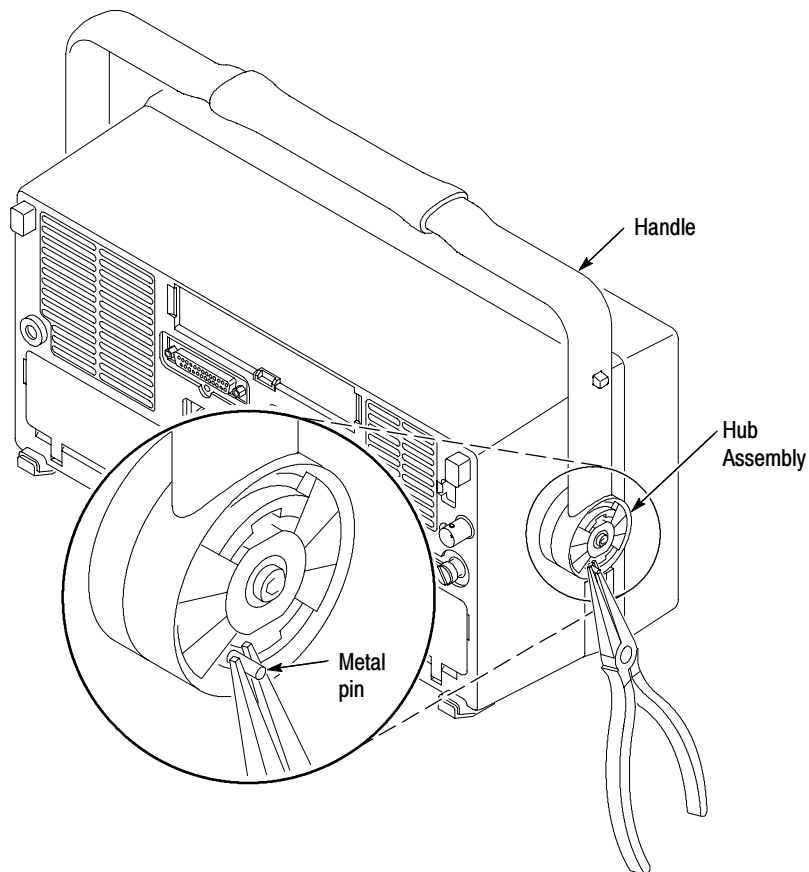

Figure 6-1: Pulling the hub pin

5. Place the oscilloscope on its feet on soft surface (such as an anti-static mat), with the display-side hub facing you.
6. Rotate the handle two detent positions toward the rear of the oscilloscope. The hub should rotate with the handle. If the hub does not rotate with the handle, return the handle to the upright position, pull the pin out a little farther, and then rotate the handle toward the rear of the oscilloscope.
7. Pull outward on the handle at the hub to release the display-side hub assembly. You may need to rotate the handle up and down slightly to help release the hub assembly. See Figure 6-2.

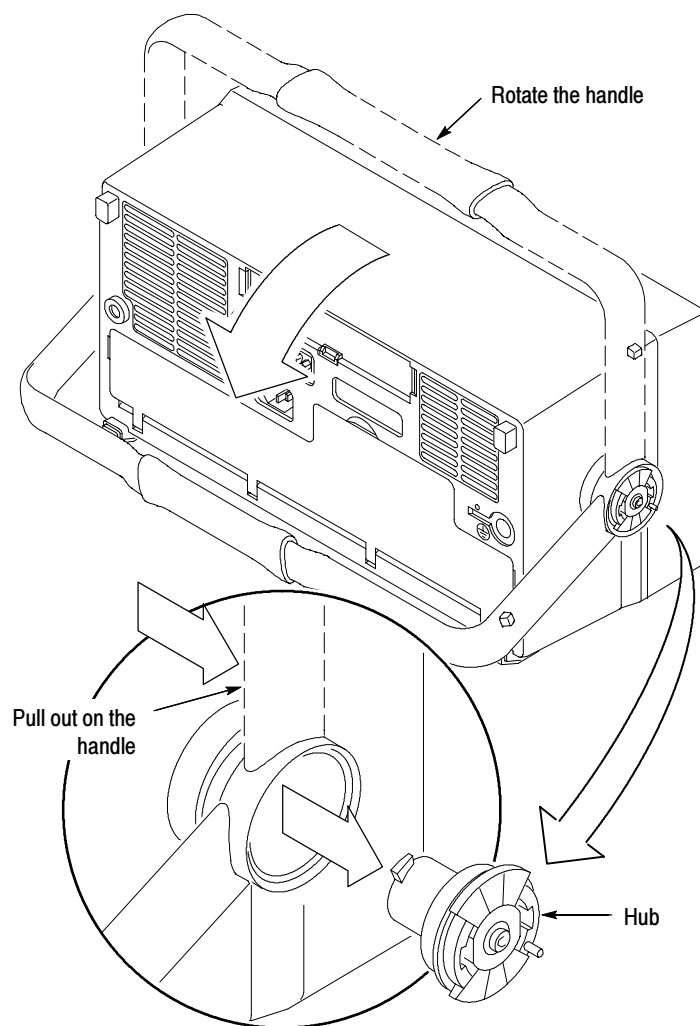

Figure 6-2: Releasing the hub assembly

8. Locate the remaining hub on the opposite side of the oscilloscope. Place the oscilloscope with the remaining hub facing you. Keep the handle at the same position used in step 6.
9. Use the needle-nose pliers to pull the metal pin in the remaining hub outward approximately 6 mm (0.25 in).
10. Raise the handle to its full upright position. The hub should rotate with the handle. If the hub does not rotate with the handle, return the handle to the down position, pull the pin out a little farther, and then rotate the handle toward the top of the oscilloscope.
11. Pull outward on the handle to release the remaining hub assembly. You may need to rotate the handle back and forth slightly to help release the hub assembly.
12. Grasp the handle on both sides and pull outwards to remove the handle from the oscilloscope.

Installation. Use this procedure to reinstall the handle.

1. Place the oscilloscope on its feet on soft surface (such as an anti-static mat), with the front facing you.
2. Verify that the front and rear cases fit together tightly.
3. Grasp the handle from both sides and stretch it over the over the top of the oscilloscope. Rotate the handle into its full upright position. The Tektronix logo should appear right-side up when looking down on the handle.
4. Insert one hub assembly into the handle on the right side (non display side) of the oscilloscope. The hub assembly can go in one of two ways, 180° apart; either way is ok.
5. While pressing in on the hub assembly with your fingers, rotate the handle away from you into its lowest position. The hub assembly should rotate with the handle.
6. Use the $\frac{1}{8}$ inch flat-bladed screwdriver to push the metal pin in to lock the hub assembly. Once locked, the hub assembly should not rotate when you rotate the handle.
7. With the handle in its lowest position, insert the remaining hub assembly into the handle on the display side of the oscilloscope.

8. While pressing in on the hub assembly with your fingers, rotate the handle to its full upright position. The hub assembly should rotate with the handle.
9. Use the $\frac{1}{8}$ inch flat-bladed screwdriver to push the metal pin in to lock the hub assembly.
10. Verify that both hub assemblies do not rotate when you rotate the handle.
11. Snap the hub covers into place over the hub assemblies. See Figure 6-3.

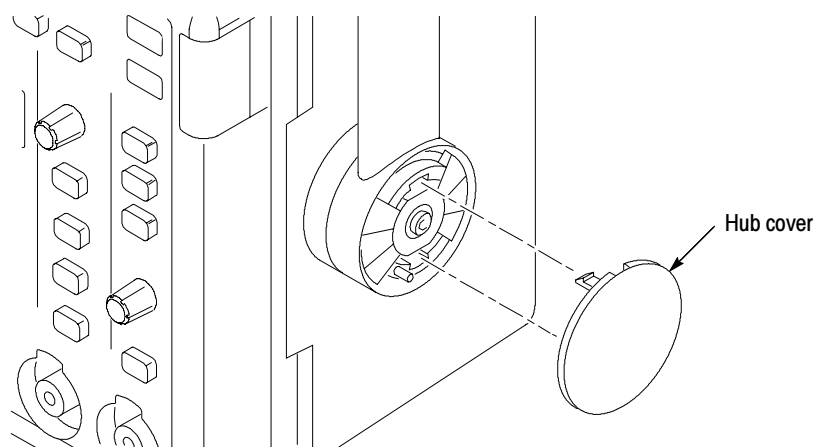

Figure 6-3: Reinstalling a hub cover

Rear Case You will need a Torx® T-15 screwdriver to remove the rear case.

Removal. Use this procedure to remove the rear case, feet, communication module cover, communication module guide, and disk drive.

NOTE. You must remove the handle assembly before you can remove the rear case. Follow the procedure on page 6-8 to remove the handle.

1. Place the oscilloscope face down on soft surface (such as an anti-static mat), with the bottom facing you.
2. Remove the T-15 Torx screw just below the parallel printer port.
3. Remove the communication module cover or any communication module that may be installed.
4. Lift the rear cover off of the oscilloscope chassis.
5. Remove both feet if necessary to replace them, otherwise leave the feet installed in the back cabinet.

6. To remove the communication module guide, gently lift the chassis to release the small communication module guide tab, move the module guide slightly away from the chassis, and then lift the module guide away from the oscilloscope. See Figure 6-4. Note that there are alignment pins along the front edge of the module guide that insert into the main board when you reinstall the module guide.

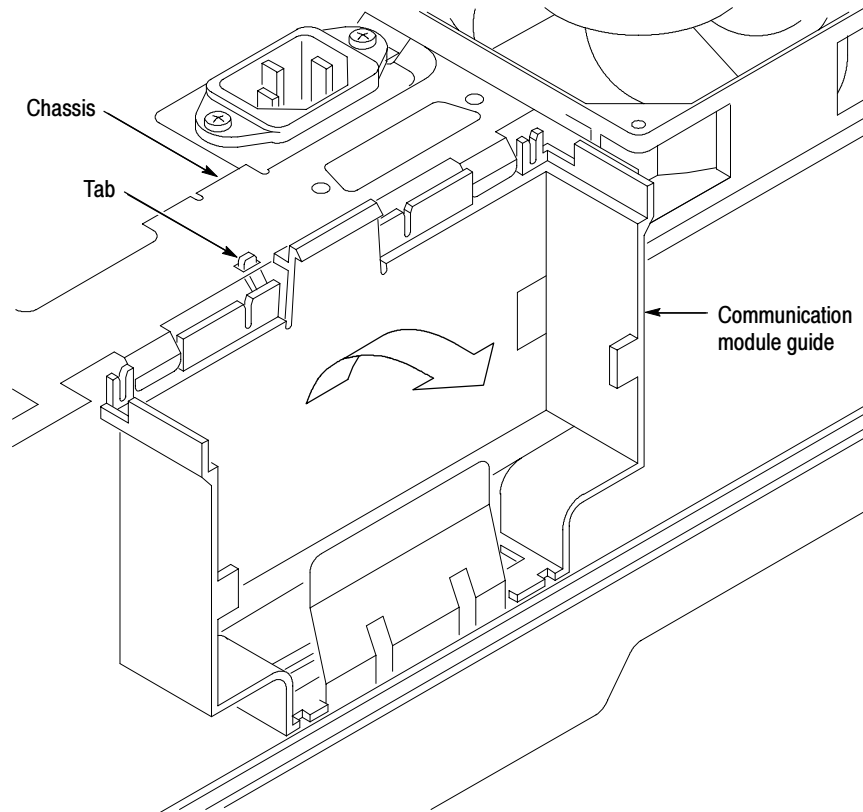

Figure 6-4: Communication module guide

7. Carefully open the disk drive flex cable main board connector J800 and disconnect the disk drive flex cable from the main board. See Figure 6-5. The disk drive is shown removed to provide a better view of the position of the main board disk drive flex cable connector J800.
8. Lift the disk drive out of the oscilloscope front panel chassis. Do not remove the clear tape that holds the flex cable onto the disk drive chassis unless you are replacing either the disk drive or the flex cable.

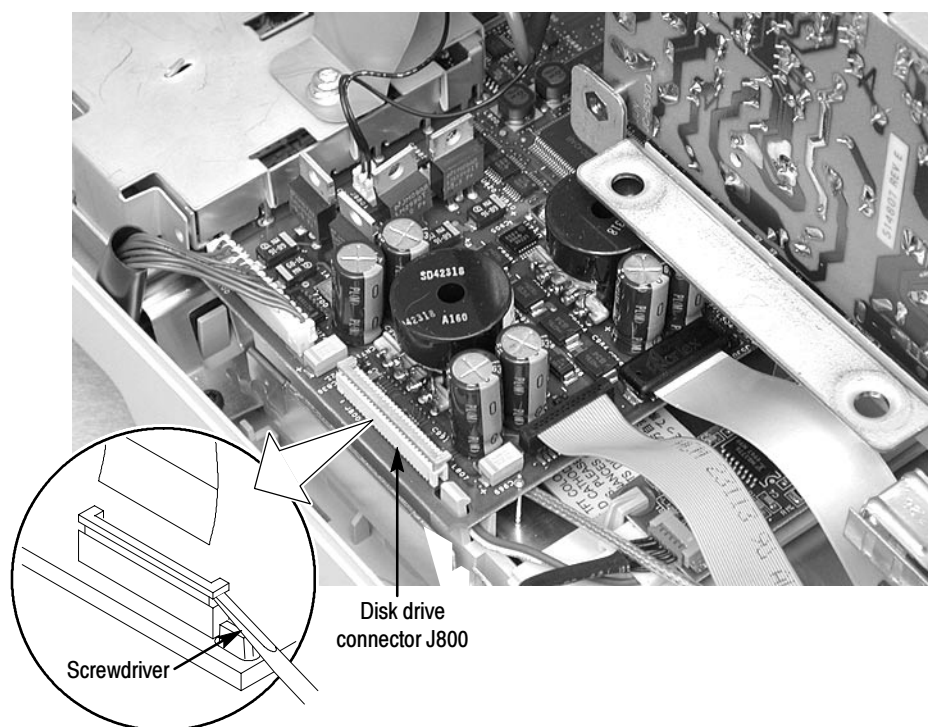

Figure 6-5: Main board disk drive flex cable connector J800

Installation. Use this procedure to install the disk drive, communication module guide, feet, rear case, and communication module cover.

1. Place the oscilloscope face down on soft surface (such as an anti-static mat), with the bottom facing you.
2. Install the communication module guide into the chassis. Make sure that the four pins on the module guide align with the four holes on the main board. Gently lift the rear chassis and insert the small tab in the chassis slot.

3. Install the feet into the front case if you removed them in a previous step.
4. Place the disk drive into its cavity in the front panel chassis. The flex cable should align with connector J800 on the main board. Be careful not to bend or break the metal grounding fingers that are in the front panel disk drive cavity.

NOTE. *If you are installing a new disk drive, remove the plastic bezel from the new disk drive and discard the bezel. See Figure 6-6.*

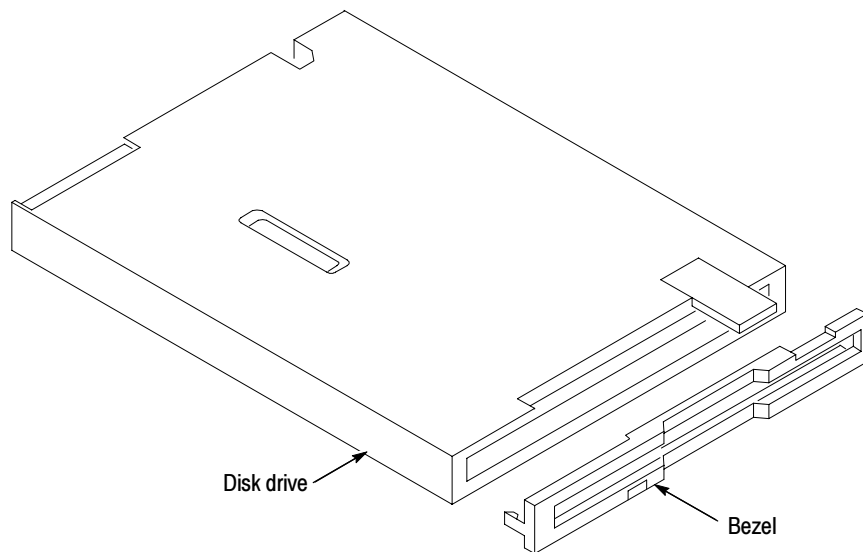

Figure 6-6: Removing the bezel from a new disk drive

5. Carefully open main board connector J800, insert the disk drive flex connector, and then close the connector. See Figure 6-5.
6. Place the rear case over the oscilloscope chassis and lower it. Be sure that the disk drive is captured inside the case and does not slip from its correct position. The rear case should fit over and capture the feet.
7. Press the rear case downward so that it is seated completely.
8. Install the screw below the parallel port connector.

NOTE. The screw installed below the parallel printer connector is 0.25 inches long. Make sure you use the correct-length screw when attaching the rear cabinet to the rear chassis.

9. Install the communication module cover or a communication module.

Rear Chassis

You will need a Torx® T-15 screwdriver to remove the rear chassis. You will need a $\frac{3}{16}$ inch nut driver to remove the parallel printer port cable.

Removal. Use this procedure to remove the rear chassis, battery board, external power jack, power supply, power supply bracket, line filter, fan, and parallel printer port cable.

1. Place the oscilloscope face down on soft surface (such as an anti-static mat), with the bottom facing you.
2. Disconnect the following cables (see Figure 6-7):
 - a. The line trigger cable from main board connector J980.
 - b. The DC power cable from main board connector J900. See the Caution note in step 20 on page 6-21 before reconnecting the DC power cable to J900 on the main board.
 - c. The parallel port ribbon cable from main board connector J810.
 - d. The display backlight power cable from the display backlight board.
 - e. The Ethernet cable from main board connector J910.
3. Remove the four screws that secure the rear chassis to the front chassis. Two screws are near the Ethernet connector, one screw is by the cooling fan, and one screw is on the AC line filter shield (see Figure 6-7, top photograph).
4. Lift the rear chassis assembly partially away from the front chassis.
5. Unplug the braided cable from the rear chassis BNC connector (four-channel models only). Note how the cable is routed for when you reassemble the instrument.

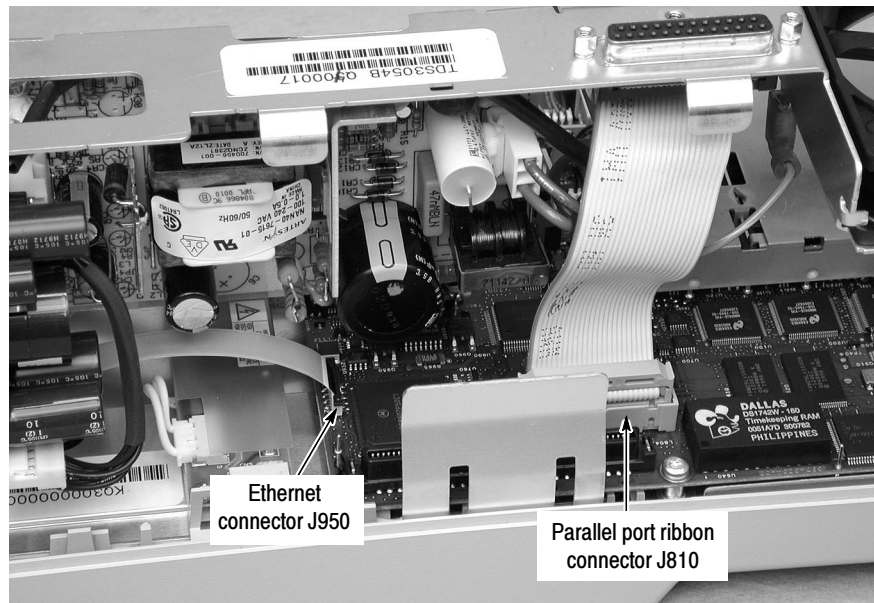
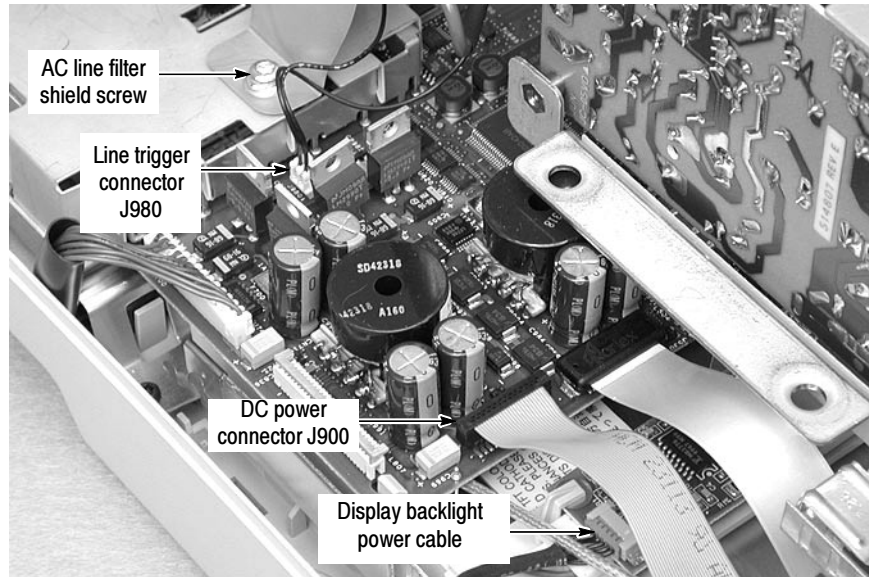

Figure 6-7: Rear chassis cables to the main board

STOP. *If you do not need to disassemble the rear chassis assembly, go to the Main Board procedure on page 6-22. The following instructions describe complete disassembly of the rear chassis assembly. However, you can just remove the modules from the rear chassis that appear to be in the way of the module you need to access.*

Battery Board Removal. Use the following steps to remove the battery board from the rear chassis.

1. Remove the plastic power switch extension from the power switch if necessary.
2. Remove the two screws that secure the battery board to the rear chassis.
3. Unsnap the battery board from the rear chassis. You can use the $\frac{1}{8}$ inch flat-bladed screwdriver to help release the board from the snap post.
4. Disconnect the fan cable from the battery board. You can use the $\frac{1}{8}$ inch flat-bladed screwdriver to help undo the connection.
5. Disconnect the six-wire connector from J180 on the battery board. The battery board is now completely disconnected from the rear chassis.
6. You do not need to disconnect the DC power cable from J200. If you do disconnect the DC power cable, see the Caution note in step 20 on page 6-21 before reconnecting the DC power cable to J200 on the battery board.

Power Supply Board Removal. Use the following steps to remove the power supply board from the rear chassis.

1. Disconnect the AC line power cable from the power supply.
2. Remove the two screws that secure the power supply to the rear chassis. The power supply board is now completely disconnected from the rear chassis.
3. If you are replacing the power supply board, remove the two screws that secure the power supply to the power supply bracket, and install the bracket on the new power supply board.

Parallel Port Cable, AC Filter, and Fan Removal. Use the following steps to remove the parallel port cable, AC filter, and fan from the rear chassis.

1. Use the $\frac{3}{16}$ inch nut driver to remove the two jack posts that secure the parallel port cable to the rear chassis. Do not lose the washers.
2. Remove the AC line power cable from the line filter and from the tab on the chassis.
3. Remove the two screws that secure the line filter to the rear chassis.
4. Carefully bend the tabs that secure the fan to the rear chassis and remove the fan.

Installation. Use this procedure to install the fan, line filter, parallel printer port cable, external power jack, power supply, battery board, and rear chassis. Skip the steps for modules that are already installed.

1. Insert the fan cable through the hole in the rear chassis and place the fan in its cavity. The fan label should face toward the rear chassis. See Figure 6-8.

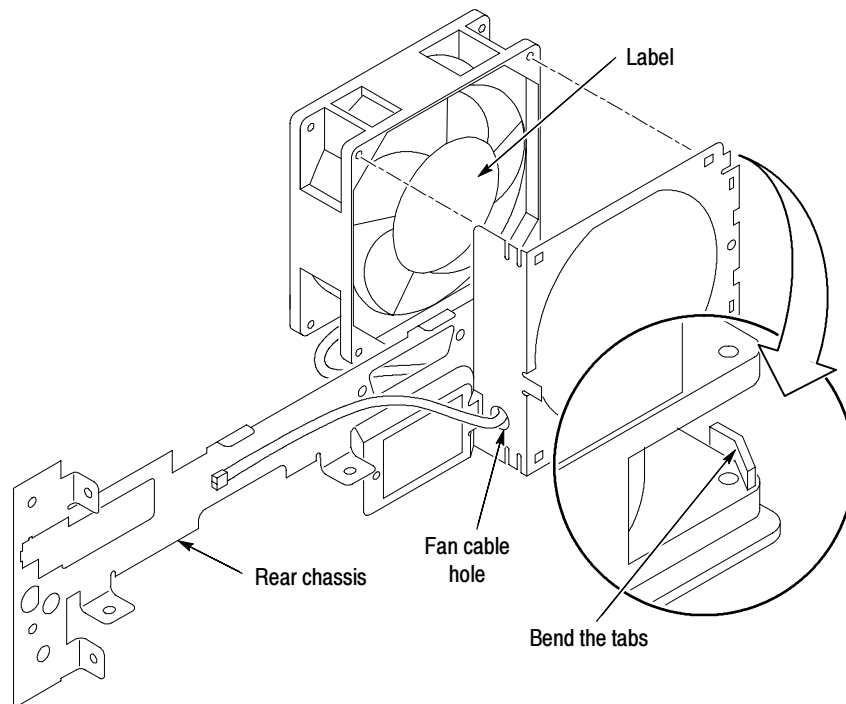

Figure 6-8: Installing the fan, line filter, and line power cable

2. Place the AC filter shield over the rear chassis AC line filter opening, and then insert the line filter into the rear chassis. Position the AC line filter so that the ground conductor tab faces toward the bottom of the instrument. Secure the AC shield/filter assembly with two screws. See Figure 6-9.

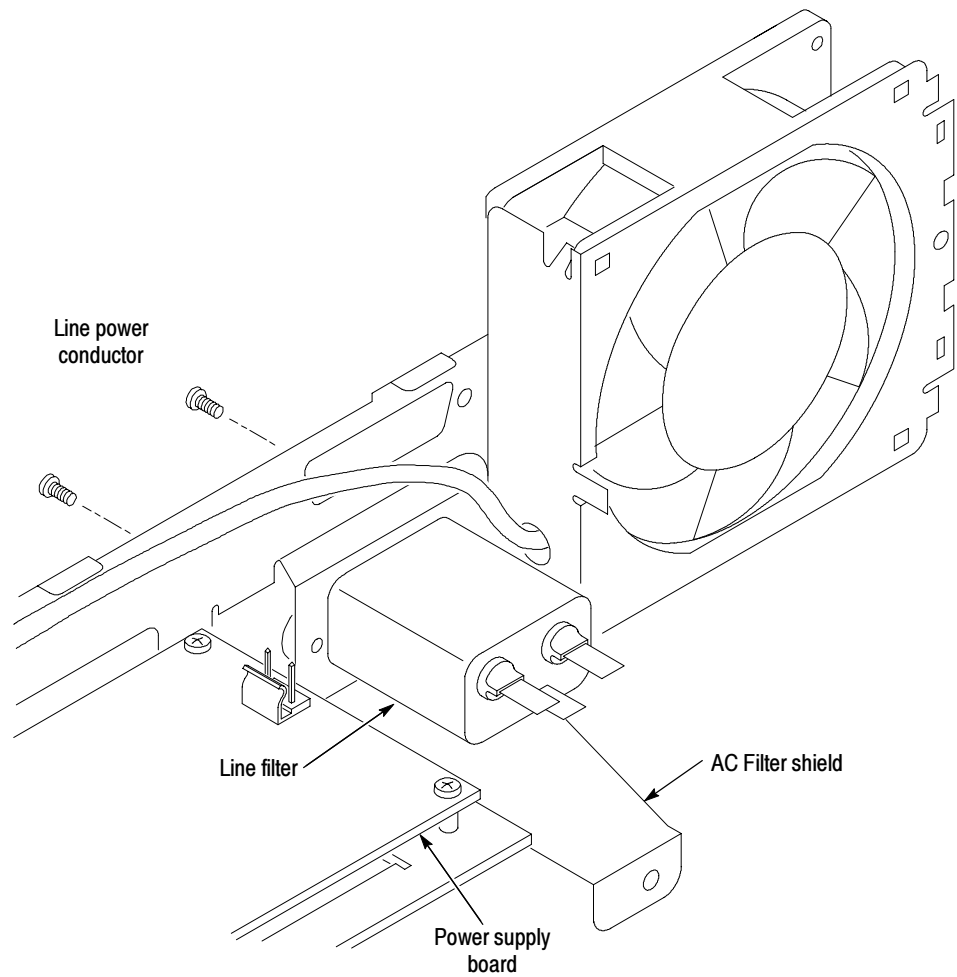

Figure 6-9: Installing the AC line filter and shield

3. Connect the line power cable connectors to the line filter and the tab on the rear chassis. See Figure 6-10.

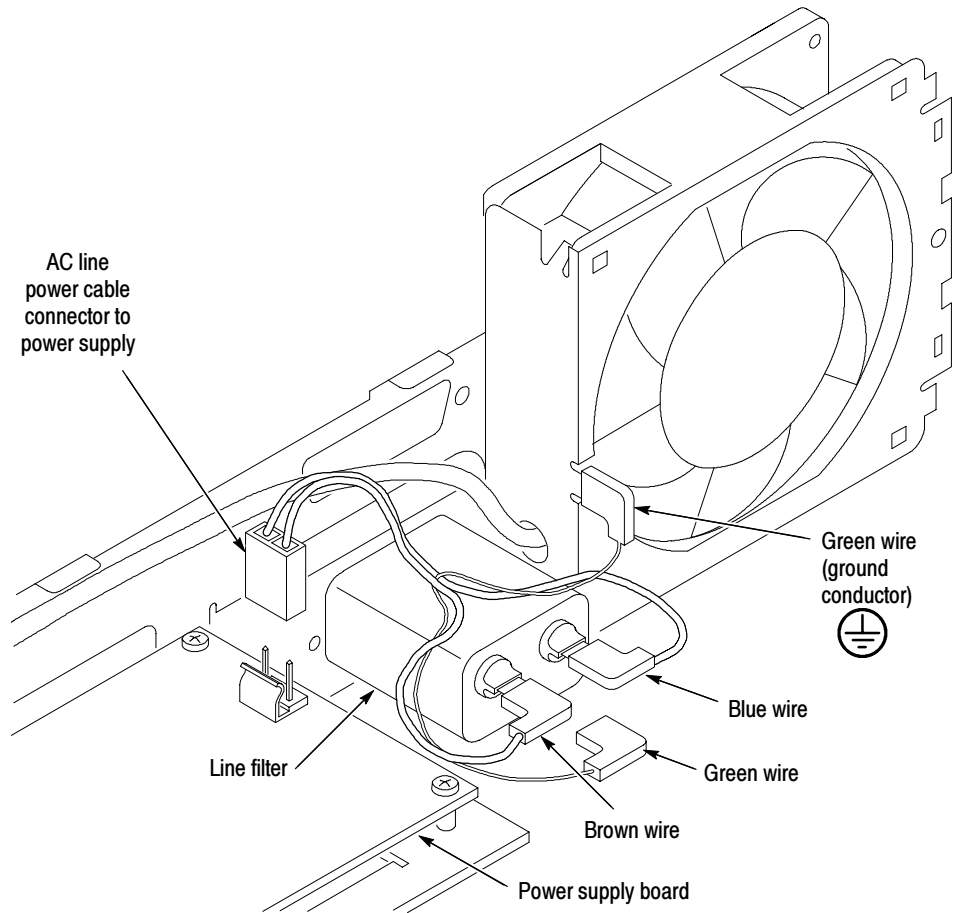

Figure 6- 10: Installing the line filter and line power cable

4. Attach the power supply to the rear chassis with two screws. The fuse side of the power supply board should face the line filter.
5. If you installed a new power supply, attach the power supply bracket to the power supply with two screws. The snap post on the bracket should be on the side of the power supply that is opposite the fuse.
6. Attach the AC line power cable to the power supply.
7. Attach the DC power cable to the power supply.
8. Connect the fan power cable to the battery board at J170.
9. Connect the DC power cable to the battery board at J180.

10. Snap the battery board onto the post on the rear chassis.
11. Install two screws to secure the battery board to the rear chassis.
12. Insert the parallel printer connector into the hole in the rear chassis and secure the connector with the two jack posts with the $\frac{3}{16}$ inch nut driver. Do not forget the washers that go on the jack posts.
13. Install the power switch extension onto the power switch so that it angles outward and to the side of the rear chassis assembly.
14. Place the oscilloscope assembly face down on soft surface (such as an anti-static mat), with the bottom facing you.
15. Position the rear chassis assembly above the oscilloscope assembly.
16. Dress the DC power cable under the power supply and toward you.
17. Insert the braided external trigger cable into the BNC connector on the rear chassis (four-channel models only).
18. Position the left side (fan end) of the rear chassis onto the two small tabs.
19. Secure the rear chassis to the front chassis with four screws (two screws near the BNC connector, one screw on the fan end of the chassis, and one screw onto the AC filter shield).
20. Connect the DC power cable to the main board at J900.



CAUTION. *This note applies to TDS3000B instruments with serial numbers less than or equal to the following:*

<i>TDS3012B</i>	<i>≤ B012691</i>
<i>TDS3014B</i>	<i>≤ B012175</i>
<i>TDS3032B</i>	<i>≤ B012507</i>
<i>TDS3034B</i>	<i>≤ B012023</i>
<i>TDS3052B</i>	<i>≤ B011153</i>
<i>TDS3054B</i>	<i>≤ B012408</i>

Make sure that the DC power cable (battery board to main board) is correctly aligned with the pins on both the battery board J200 connector and the main board J900 connector. Installing the cable incorrectly (offset left or right) onto J200 or J900 can cause board damage when you connect power to the instrument.

TDS3000B instruments with serial numbers greater than those listed above use keyed cable and board connectors.

21. Connect the parallel printer port cable to the main board. See Figure 6-7.

Main Board You will need a $\frac{1}{8}$ inch flat-bladed screwdriver and a Torx® T-15 screwdriver to remove the main board.

Removal. Use this procedure to remove the disk drive cable and main board.

1. Place the oscilloscope assembly face down on a soft surface (such as an anti-static mat), with the bottom facing you.
2. If present, remove the clip from the J500 connector. See Figure 6-11.

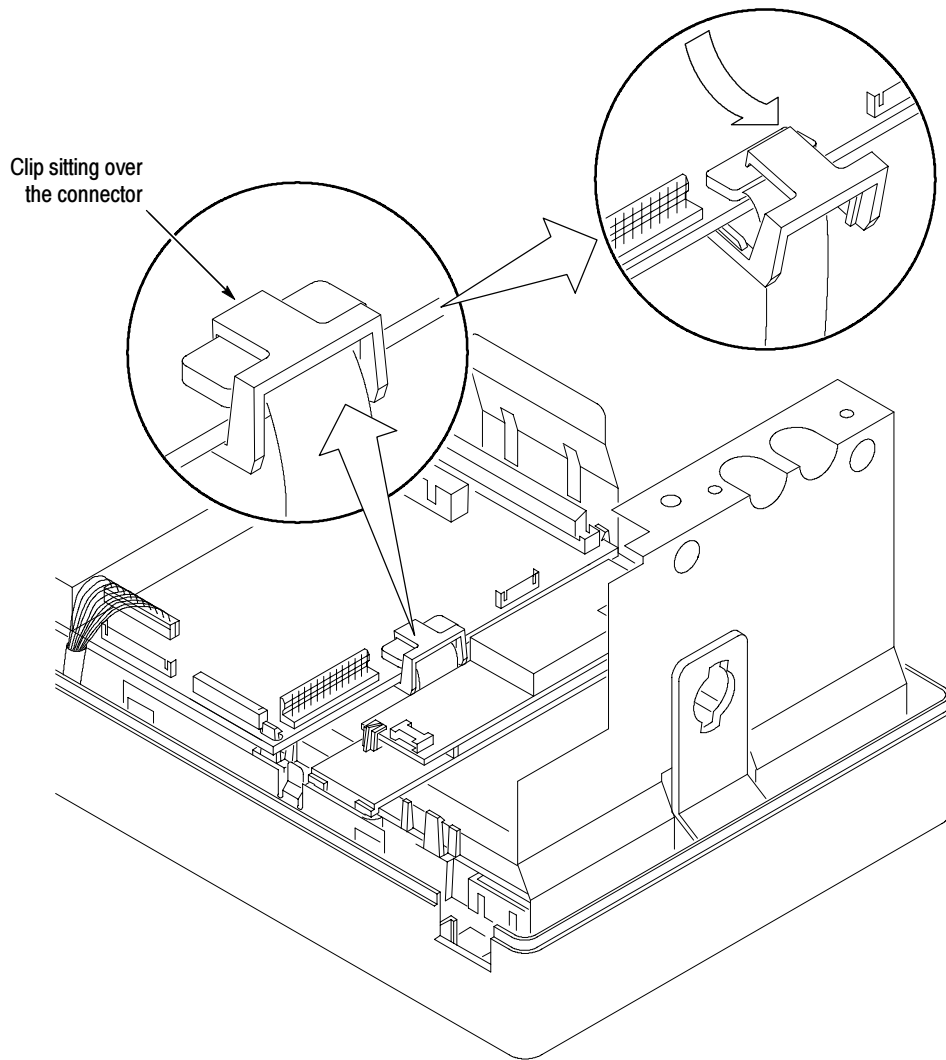

Figure 6-11: Removing clip from J500 connector

3. Use the $\frac{1}{8}$ inch flat-bladed screwdriver to carefully lift the display cable from connector J500 on the main board. See Figure 6-12.
4. Grasp and pull up on the front-panel cable wires to disconnect the cable from J700 on the main board. See Figure 6-12.

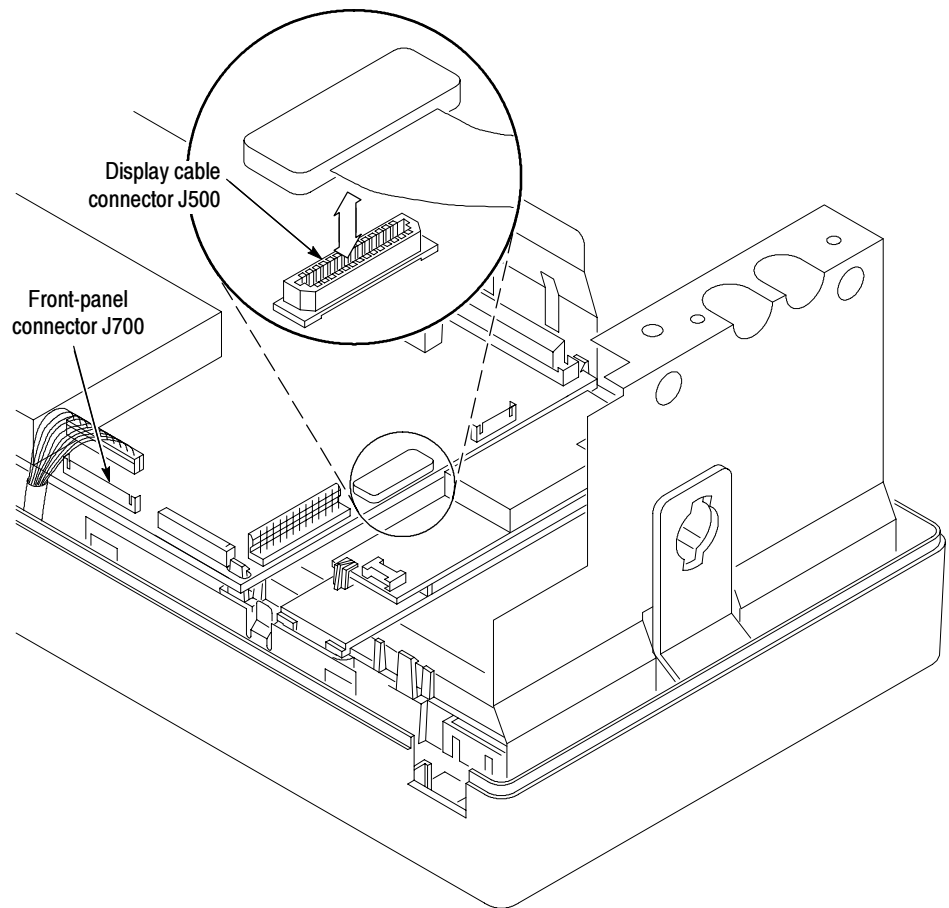

Figure 6-12: Disconnect main board cable connectors

5. Use a magnetic Torx® T-15 screwdriver (long bit) to remove the four screws that secure the main board to the front-panel assembly. See Figure 6-13.

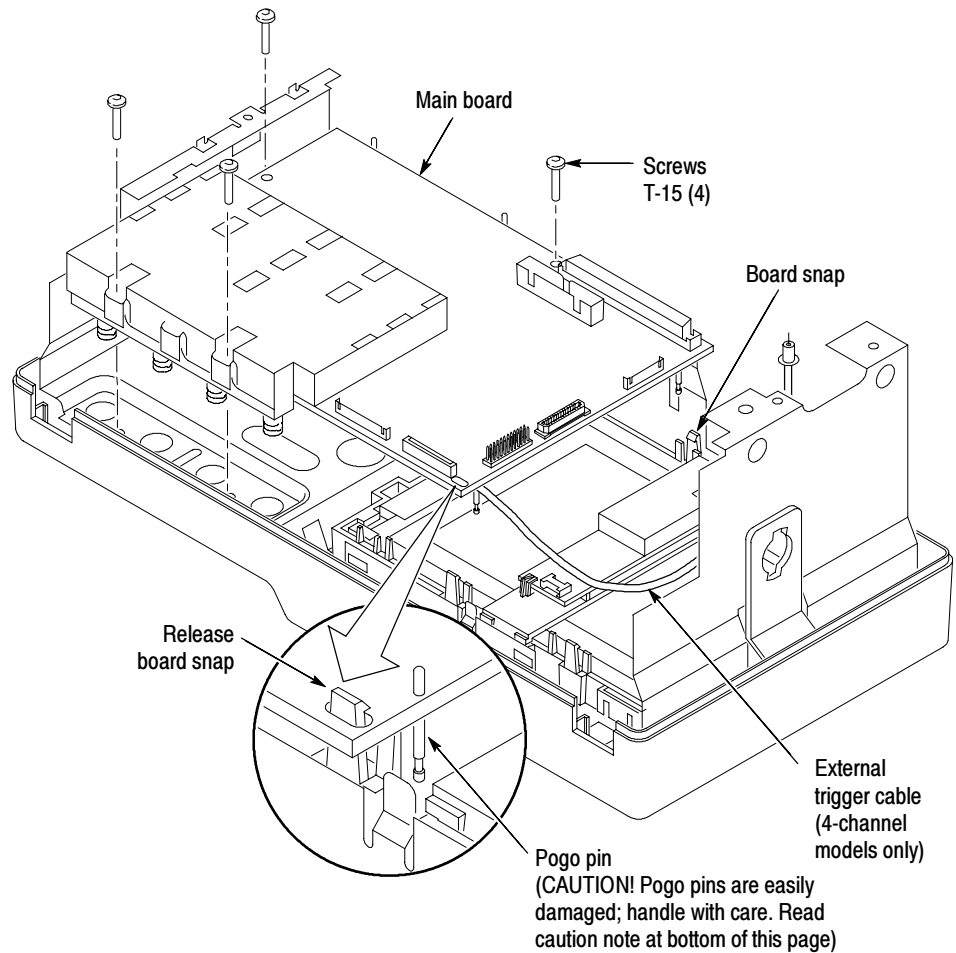

Figure 6-13: Main Board

6. Release the two snaps that hold the main board (see Figure 6-13). Lift the main board out of the front-panel assembly.



CAUTION. *There are a number of small pogo-style pins that extend from the main board to contact the front chassis. These pins are easily damaged. Use the following guidelines whenever you handle the main board:*

- *Always place the main board on your work surface with the pogo pins facing up*
- *Do not apply any sideways force on the pogo pins, or slide any objects across the pogo pins, as they are easily bent*

-
- *If replacing the main board, place the old main board on the main board foam carrier that came with the new main board*
 - *If you are temporarily placing the main board in an anti-static bag for protection, use a bag that is large enough to prevent putting strain on the pogo pins*
 - *If you are temporarily placing the main board in an anti-static bag for protection, hold the bag open while inserting the main board; do not allow the bag to slide across the pogo pins*
-

Installation. Use this procedure to install the main board and reconnect cables.

1. Place the oscilloscope front-panel assembly face down on soft surface (such as an anti-static mat), with the bottom facing you.
2. With the front-panel cable dressed out of the way, lower the main board into the front chassis assembly. Be careful not to bend or damage any of the pogo pins while handling or installing the main board.
3. Insert the display cable into the J500 connector, support the main board, and push down firmly on the connector to seat it.



CAUTION. *Do not flex the main board while seating the display cable into main board connector J500. Board damage may result. Carefully support the area under J500 while seating the cable connector.*

4. Push down on the two main board corners to engage the snaps.
5. If present, reinstall the display cable clip onto the J500 connector. See Figure 6-14.

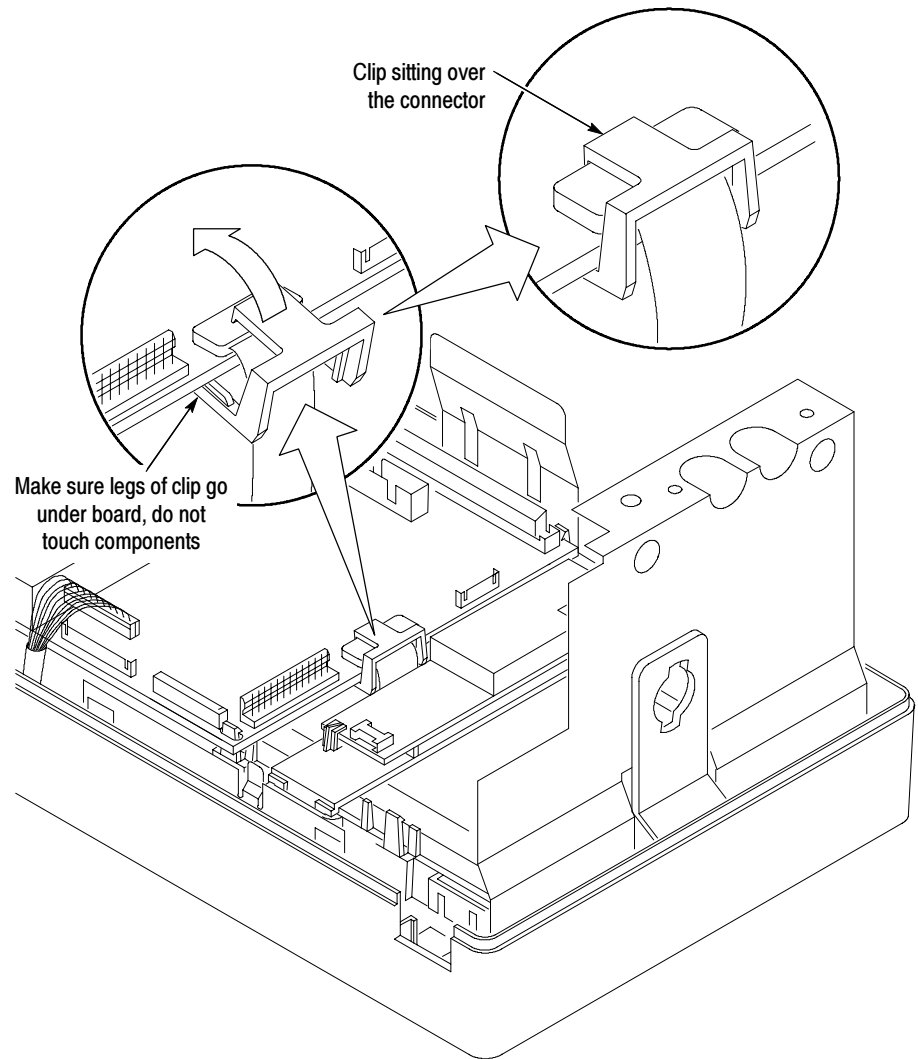

Figure 6-14: Install clip on J500 connector

6. Use a magnetic long-bit Torx® T-15 screwdriver to install the four screws that secure the main board to the front-panel assembly.

NOTE. *If after assembling the oscilloscope the display shows streaks, bars, garbled data, or no image, open the instrument case and make sure that the display cable is firmly and completely seated into connector J500.*

7. Connect the front-panel cable to the main board at J700.

Front Chassis and Display Module

You will need a Torx® T-10 screwdriver to remove the front chassis.

Removal. Use this procedure to remove the front chassis and the display module.

1. Place the oscilloscope face down on a soft surface (such as an anti-static mat), with the bottom facing you.
2. Use the Torx® T-10 screwdriver to remove the two screws that secure the front chassis to the front case. See Figure 6-15.

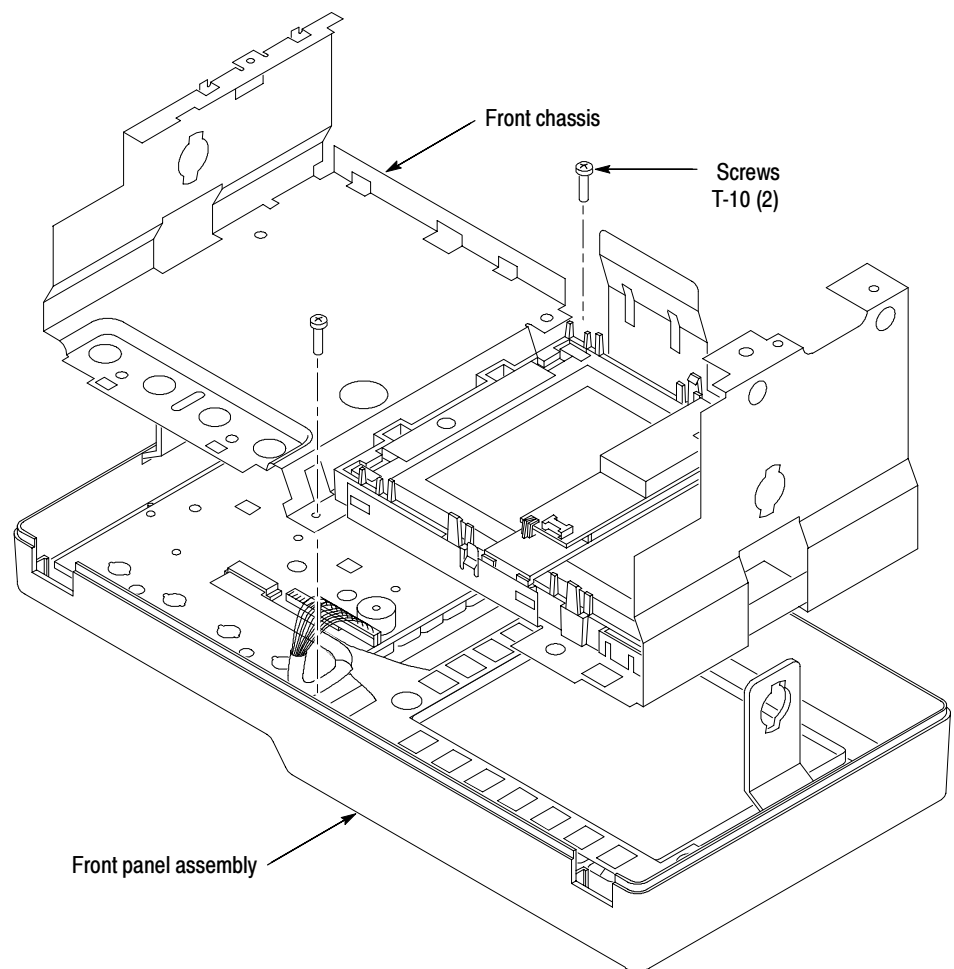

Figure 6-15: Front chassis

3. Lift the front chassis out of the front case. Lifting the left end of the chassis slightly ahead of the right end helps to clear a slight interference at the right end of the chassis.

NOTE. It is possible to remove the inverter board without removing the front chassis or display module. If this is the only thing you need to do, skip to step 1 on page 6-30.

4. Place the front chassis with the display facing you. See Figure 6-16.
5. Use your thumbs to slide the top display module tabs up until the overhanging part of the tabs clear the chassis holes. See Figure 6-16.
6. Push the tabs through the chassis holes to remove the display module.

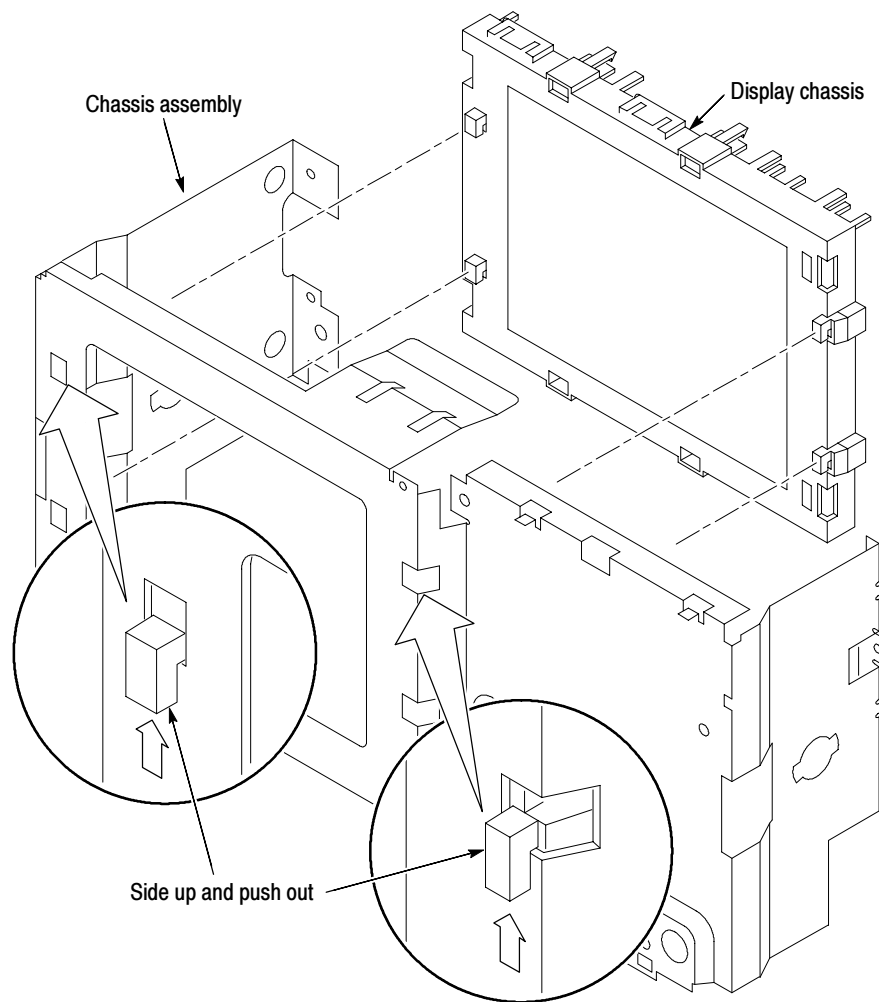

Figure 6-16: Display module

Installation. Use this procedure to install the display module into the front chassis and install the front chassis.

1. Place the front chassis with the display facing you. See Figure 6-16.
2. Push the display module tabs through the chassis holes.
3. Use your thumbs to slide all four display module tabs down as far as possible to lock the display module in place on the front chassis.
4. Place the oscilloscope face down on a soft surface (such as an anti-static mat), with the bottom facing you.
5. Route the front-panel cable so that it lies parallel to and along the top edge of the bezel button flex circuit. Position the black vinyl cable cover so that the wires are exposed from the front panel connector to just over the edge of the front panel board.
6. Route the front panel cable through the cable post on the front panel and tuck part of the cable just under the bottom corner of the front panel board. See Figure 6-17.

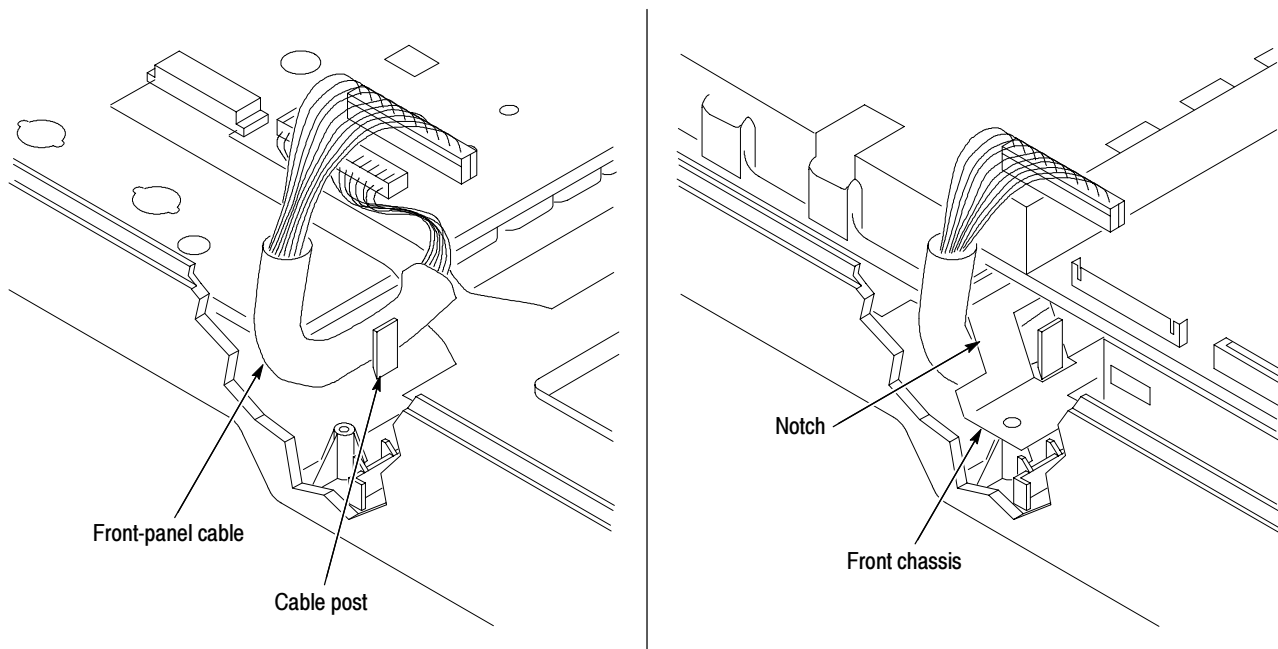

Figure 6-17: Front-panel cable routing

7. Insert the front chassis assembly into the oscilloscope. Insert the right end of the front chassis slightly ahead of the left end to clear a slight interference at the right end of the chassis.
8. Route the front-panel cable through the notch located on the bottom edge of the front chassis. See Figure 6-17.
9. Use the Torx® T-10 screwdriver to insert the two screws that secure the front chassis to the front case.

Display Inverter Board and Back light Tubes

You will need a $\frac{1}{8}$ inch flat-bladed screwdriver to remove the display module inverter board.

Removal. Use this procedure to remove the display module inverter board and back light tubes.

1. Place the display module face down on a soft surface (such as an anti-static mat), with the bottom facing you.
2. Disconnect the back light cables from the inverter board. See Figure 6-18.

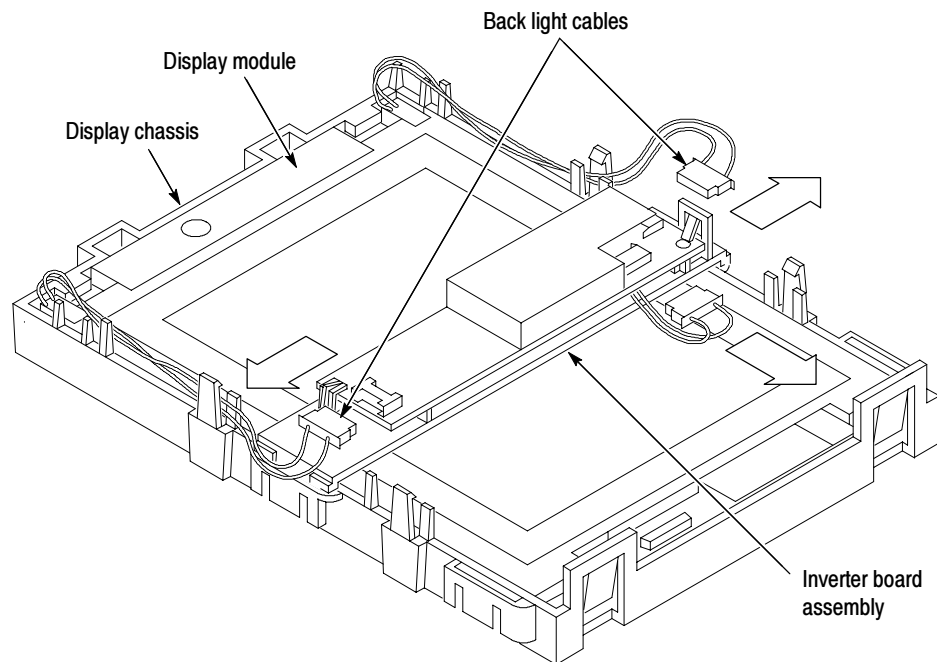

Figure 6-18: Disconnect back light cables

3. Push the tab and lift the top end of the inverter board to clear the inverter chassis. See Figure 6-19A.
4. Lift and rotate the bottom end of the inverter board to 45°-60° angle, then slide the inverter board clear of the chassis. See Figure 6-19B.
5. Use the 1/8 inch flat-bladed screwdriver to carefully lift the tab holding the bottom end of the inverter board chassis to the display chassis, and at the same time lift that end of the inverter board chassis. Repeat for the other end of the inverter board. See Figure 6-19C.

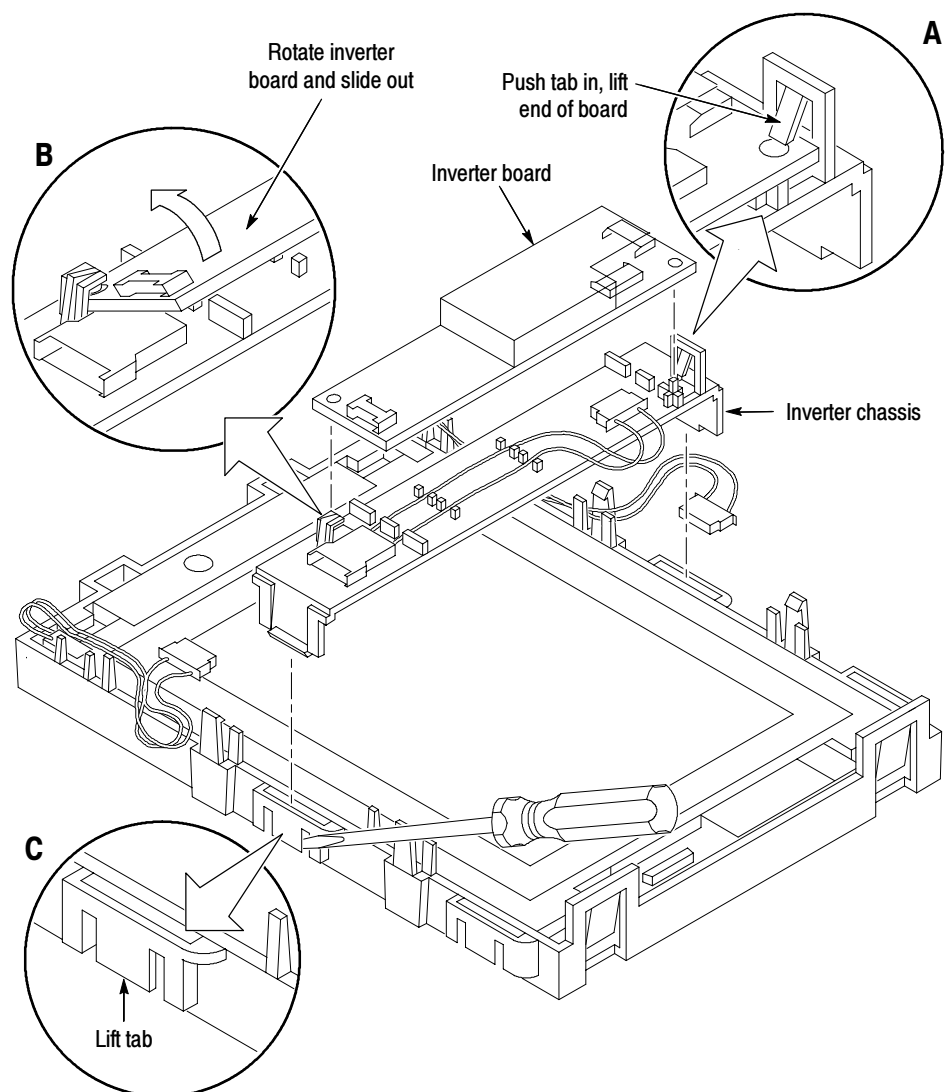

Figure 6-19: Remove inverter board

6. Use your thumb to push the tab on the top right side of the display chassis until the tab clears the display assembly. Then push the top-right corner of the display, from the front of the display, to clear the tab. Repeat for the other display chassis tab. See Figure 6-20.

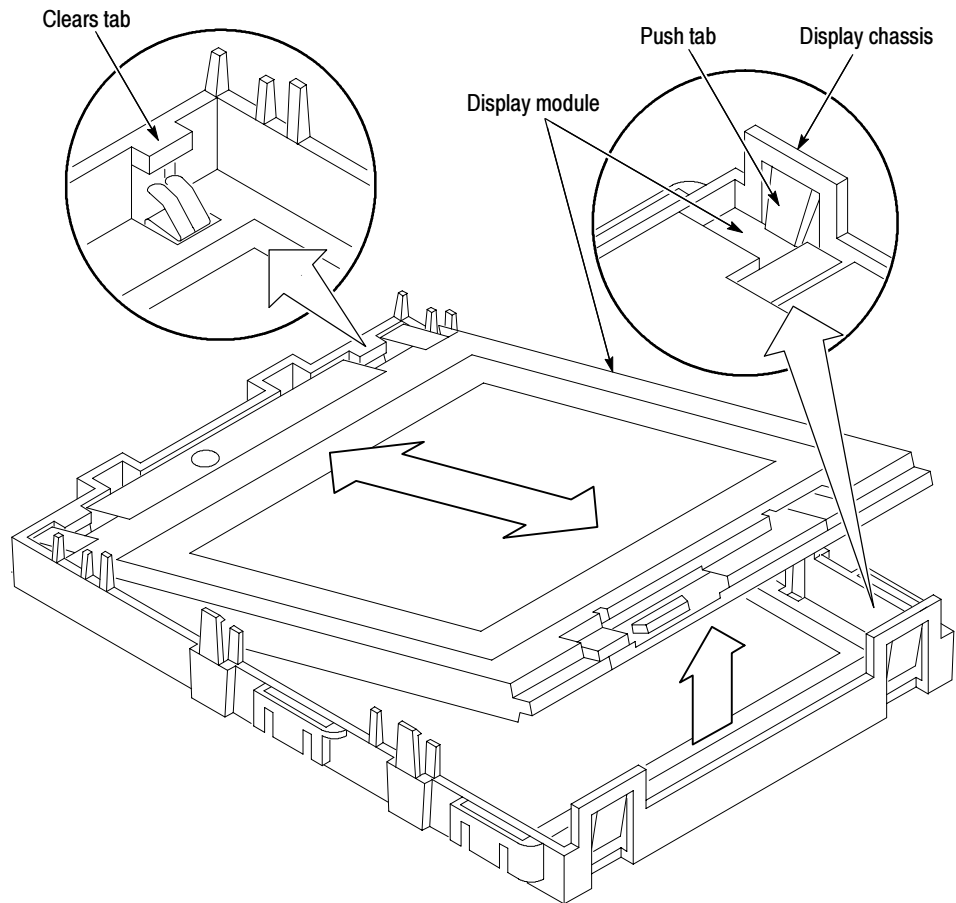

Figure 6-20: Remove display from display chassis

7. Lift the right side of the display, then pull the display to the right to clear the display from the tabs on the left side of the display chassis.

8. Use your thumb to push down the tab next to a back light tube, at the same time pulling the back light tube cable to slide the back light out of the display. See Figure 6-21.

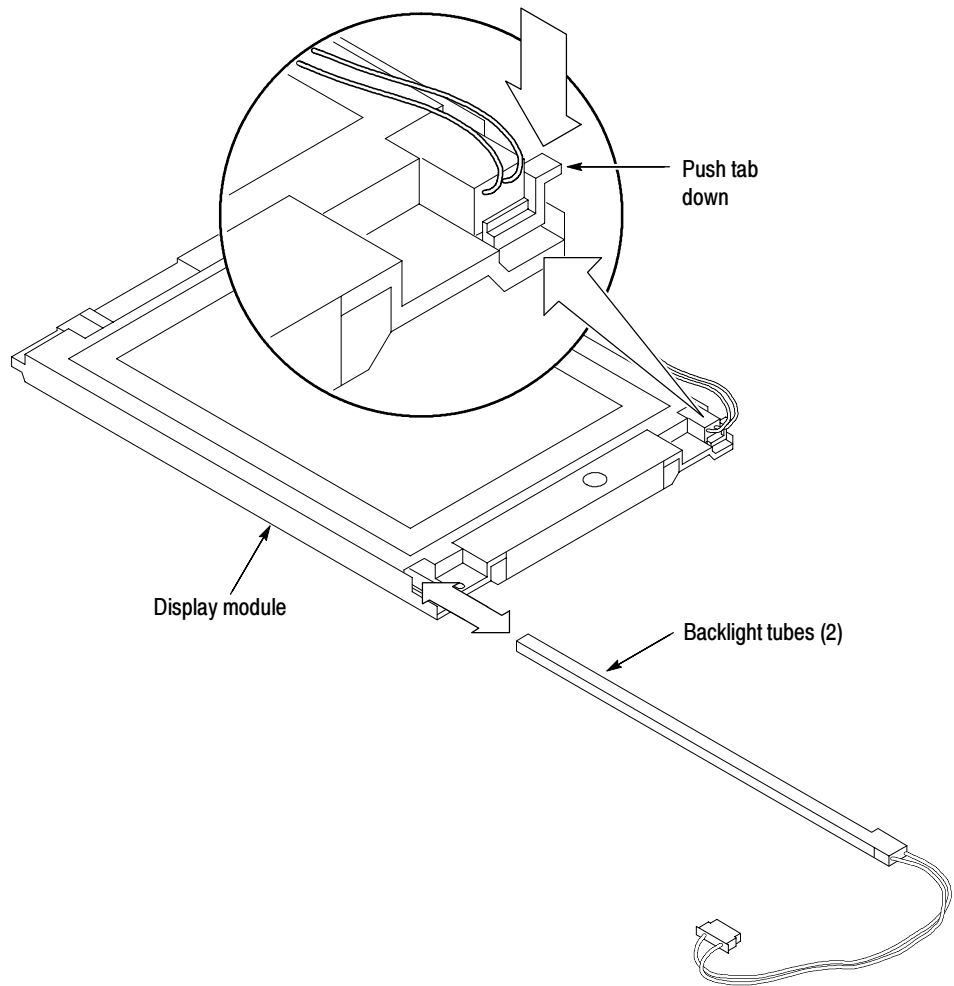

Figure 6-21: Remove back light tube

Installation. Use this procedure to reassemble the display module.

1. Insert backlight tubes into the display, with the open side of the tube toward the center of the display, until the tube clicks into place. The backlight tubes slide easily into the display when they are aligned correctly.
2. Place the display chassis face down on soft surface (such as an anti-static mat), with the bottom facing you. The extended chassis tabs should be on your right. See Figure 6-20.
3. If the glass LCD shield is detached from the display module, place the glass shield in the display chassis with the foam facing up. See Figure 6-22.

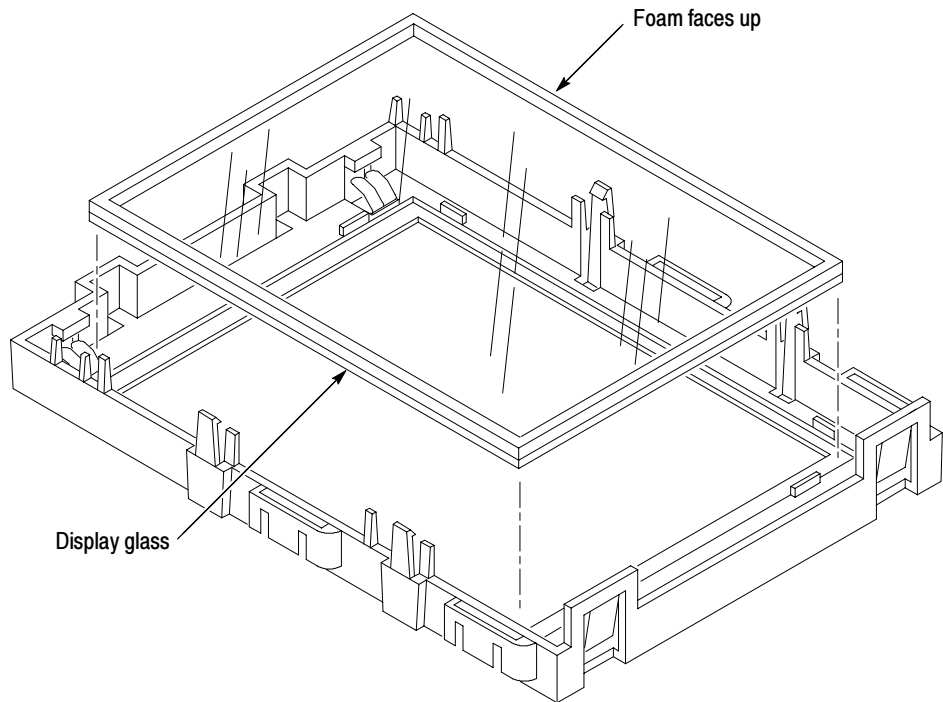

Figure 6-22: Installing display glass shield

4. Insert the left edge of the display into the display chassis so that the left edge of the display fits under the tabs. See Figure 6-20.
5. Press down firmly on the right side of the display until it clicks into place under the two display-chassis extended tabs. The tabs must be over the aluminum shield on the back of the display.

6. Insert the inverter board assembly into the slots at the top and bottom of the display chassis. The high-voltage shield end of the board is at the top of the display. Push firmly until the tabs click.
7. Insert the display back light cable connectors into the inverter board. Position the back light cables in the display chassis clips. See Figure 6-18.

Front Panel You do not need any tools to remove the front panel board.

Removal. Use this procedure to remove the front panel, front panel buttons, bezel button flex circuit, and bezel buttons.

1. Place the oscilloscope face up on a soft surface (such as an anti-static mat).
2. Remove the front-panel knobs by firmly pulling each knob away from the front panel. Careful prying with a small screwdriver or similar tool may be necessary. See Figure 6-23.

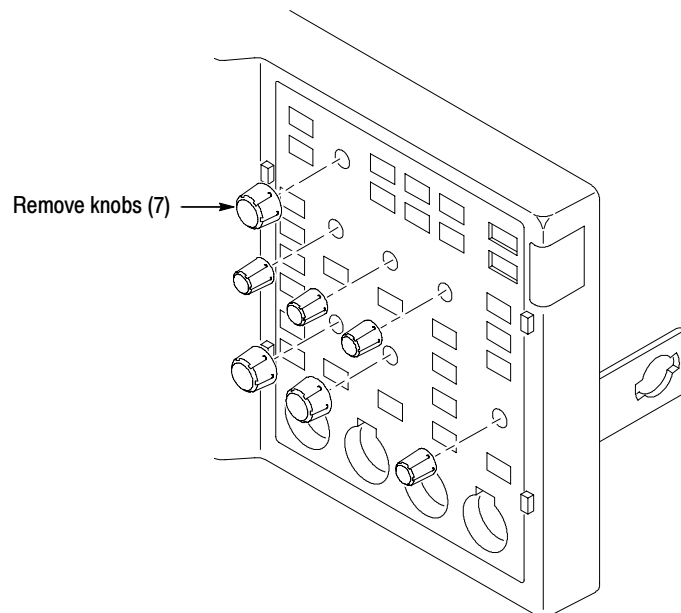

Figure 6-23: Remove front-panel knobs

3. Place the oscilloscope face down on a soft surface (such as an anti-static mat), with the bottom facing you.
4. Disconnect the bezel button flex circuit from J200 by gently pulling the flex circuit out of the connector. Gently remove the flex circuit from the front panel and place on a clean protected surface.
5. Remove the front-panel board by pulling back board snaps and lifting the lower right corner of the front-panel board. Pull back the board snaps in numeric order, starting with snap one, as shown in Figure 6-24.

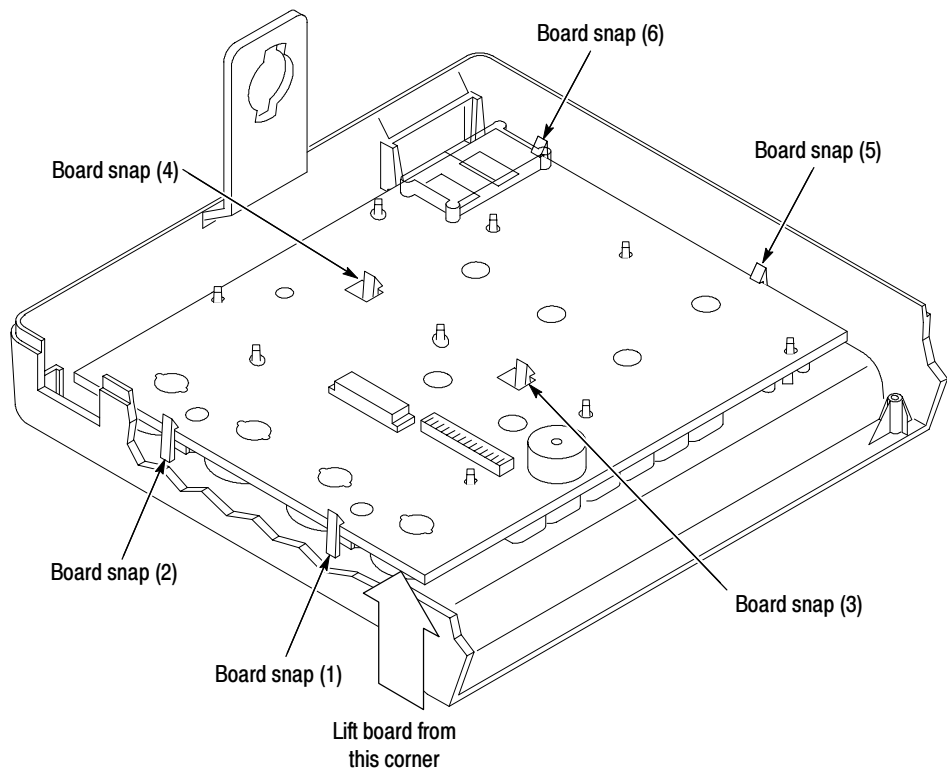

Figure 6-24: Remove front-panel board

6. Remove the front-panel and bezel button keypads by lifting them away from the front panel. Do not touch the keypad contacts or place them on a contaminated surface. See Figure 6-25.

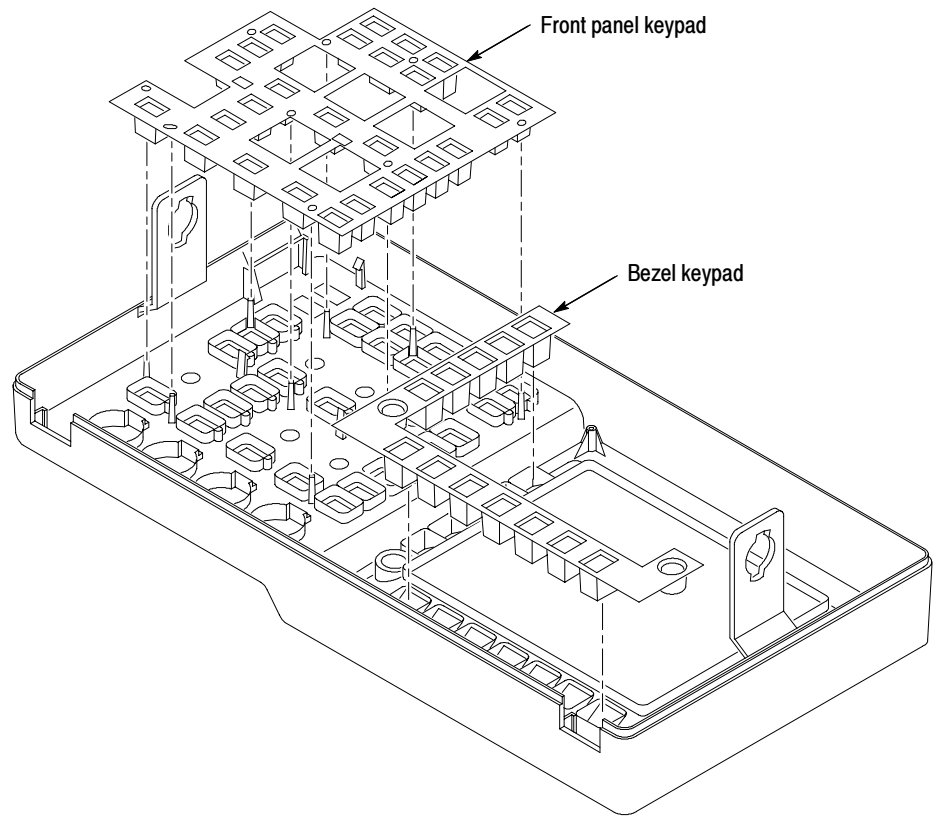

Figure 6-25: Remove front-panel keypads

Installation. Use this procedure to reinstall the front-panel board.

1. Check that the front-panel lock nuts are still in the front panel before installing the front panel keypad and board. These nuts are pressure-fit and can come loose. See Figure 6-26.

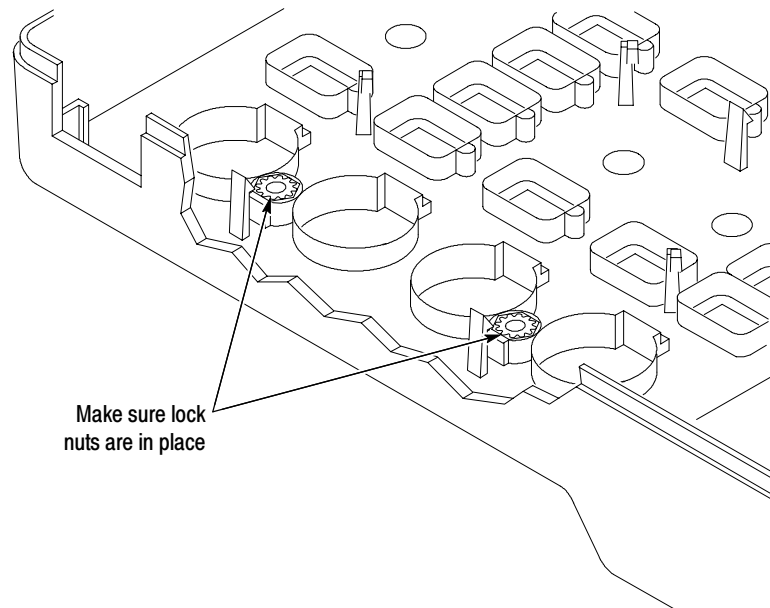

Figure 6-26: Checking front-panel lock nuts

2. Install the front-panel keypad into the front panel. Do not touch the keypad contacts. See Figure 6-25.
3. Insert the front-panel board by aligning the board with the alignment posts. Then press firmly on the board, starting at the top edge, to engage the board snaps.
4. Install the bezel button flex circuit; align the the flex circuit on the front-panel bezel button pins and gently press the flex circuit flat.
5. Connect the bezel button flex circuit to J200.
6. Route the front-panel cable as described in steps 5 and 6 on page 6-29.
7. Install the front-panel knobs by firmly pushing each knob onto the front panel knob shaft. Align the flat side of the knob shaft with the flat part of the knob hole.

Troubleshooting

This section contains information and procedures to help you isolate a defective module in a TDS3000B series oscilloscope.



WARNING. Before doing this or any other procedure in this manual, read the General Safety Summary and Service Safety Summary found at the beginning of this manual. Also, to prevent possible injury to service personnel or damage to electrical components, read Preventing ESD on page ix.

Adjustment After Repair

If you replace the main board, you must adjust the instrument after repair. Refer to the chapter *Adjustment Procedures* for information about adjustment.

Required Tools and Equipment

You need the the following equipment to troubleshoot the instrument.

Tools and Equipment	Example
DMM	Tektronix TX, DMM200, or DMM300 series handheld multimeter

Troubleshooting Procedure

Figures 6-27 through 6-29 are troubleshooting procedure flowcharts. Use them to troubleshoot an instrument failure. Begin with Figure 6-27.

NOTE. Before performing the troubleshooting procedure, remove the instrument cabinet (see page 6-5).

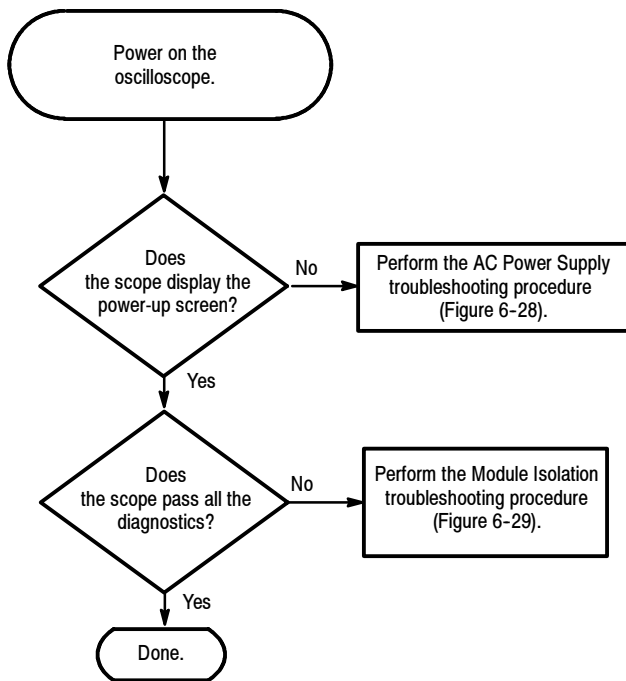

Figure 6-27: Primary troubleshooting procedure

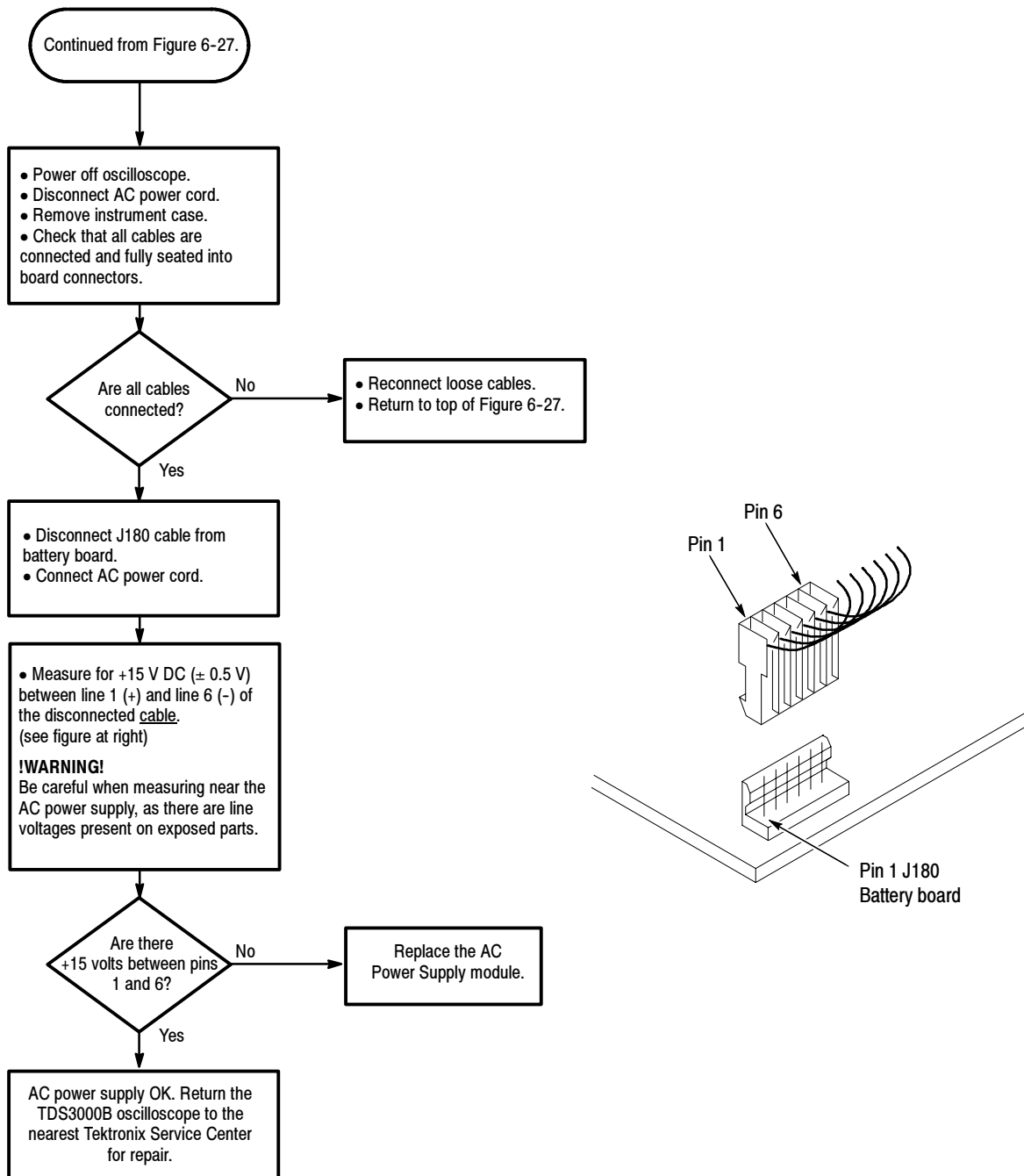
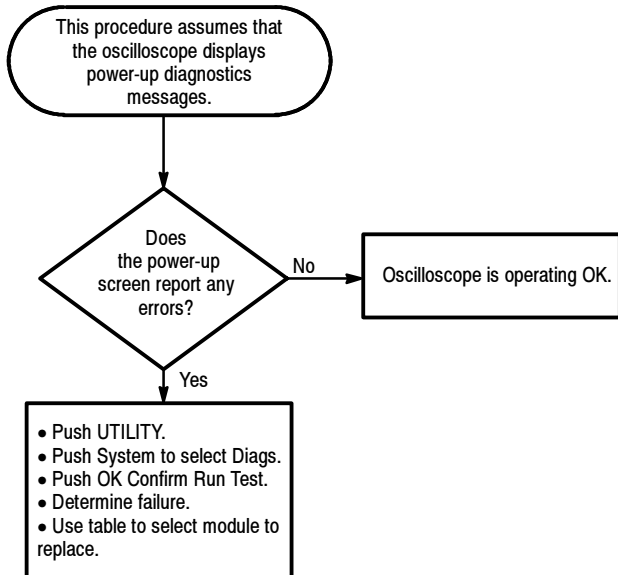

Figure 6-28: AC power supply troubleshooting procedure



Failed Test	Most Likely Cause
Acquisition	Main board
CPU	Main board
Display	Main board
Front Panel	Front Panel (or Main board)
I/O	Comm module (or Main board)
ROM	Main board
Disk Drive	Main board (or disk unit or cable)
App Modules	Front Panel (or App keys)

Figure 6-29: Module isolation troubleshooting procedure

Unpacking and Repacking Instructions

This section contains the information needed to unpack the oscilloscope and repack it for shipment or storage.

Unpacking The oscilloscope and its standard accessories are carefully packed at the factory in a shipping carton. If, upon receipt, damage to the shipping carton is evident, notify the shipper. Tektronix, Inc. is not responsible for damage caused during shipping.

If you have not already done so, carefully remove the oscilloscope and its accessories from the shipping carton and inspect them for damage. Save the shipping carton for repacking or storage.

Repacking Use a corrugated cardboard shipping carton having a test strength of at least 275 pounds (125 kg) and with an inside dimension at least six inches (15.25 cm) greater than the instrument dimensions.

If the instrument is being shipped to a Tektronix Service Center, enclose the following information:

- The owner's address
- Name and phone number of a contact person
- Type and serial number of the instrument
- Reason for returning
- A complete description of the service required

Seal the shipping carton with an industrial stapler or strapping tape.

Mark the address of the Tektronix Service Center and also your own return address on the shipping carton in two prominent locations.

Storage The oscilloscope should be stored in a clean, dry environment. The following environmental characteristics apply for both shipping and storage (instrument not operating with no disk installed):

- Temperature range: -20°C to $+60^{\circ}\text{C}$
- Altitude: To 15,000 m

See the chapter *Specifications* for a complete listing of the environmental characteristics.

Options

The TDS3000B series options, listed in Table 7-1, provide power cords and documentation packages for international customers.

Table 7-1: TDS3000B Series options

Option	Description
A1	Substitute universal European power cord (220 V)
A2	Substitute United Kingdom power cord (240 V)
A3	Substitute Australian power cord (240 V)
A5	Substitute Switzerland power cord (220 V)
L1	Substitute French-language documentation package
L2	Substitute Italian-language documentation package
L3	Substitute German-language documentation package
L4	Substitute Spanish-language documentation package
L5	Substitute Japanese-language documentation package
L6	Substitute Portuguese-language documentation package
L7	Substitute Simplified Chinese-language documentation package
L8	Substitute Traditional Chinese-language documentation package
L9	Substitute Korean-language documentation package
LR	Substitute Russian-language documentation package
E1	English-language documentation package plus Options A1, A2, A5, L1, and L3
E2	U.S. power cord (120 V) plus Options A1, L2, L4, and L6
P1	U.S. power cord (120 V) plus Options A3, L7, L8, and L9



Electrical Parts List

Refer to the *Mechanical Parts List* chapter for a complete listing and description of replaceable parts for the oscilloscope.

Diagrams

See Figure 3-1 on page 3-1 for a block/interconnect diagram of the oscilloscope. There are no additional diagrams in this chapter.

Mechanical Parts List

This chapter contains a list of the replaceable modules for the TDS3000B series oscilloscope. Use this list to identify and order replacement parts.

Parts Ordering Information

Replacement parts are available through your local Tektronix field office or representative.

Changes to Tektronix products are sometimes made to accommodate improved components as they become available and to give you the benefit of the latest improvements. Therefore, when ordering parts, it is important to include the following information in your order.

- Part number (see Part Number Revision Level below)
- Instrument type or model number
- Instrument serial number
- Instrument modification number, if applicable

If you order a part that has been replaced with a different or improved part, your local Tektronix field office or representative will contact you concerning any change in part number.

Change information, if any, is located at the rear of this manual.

Part Number Revision Level

Tektronix part numbers contain two digits that show the revision level of the part. For some parts in this manual, you will find the letters XX in place of the revision level number.



When you order parts, Tektronix will provide you with the most current part for your product type, serial number, and modification (if applicable). At the time of your order, Tektronix will determine the part number revision level needed for your product, based on the information you provide.

Module Servicing Modules can be serviced by selecting one of the following three options. Contact your local Tektronix service center or representative for repair assistance.

Module Exchange. In some cases you may exchange your module for a remanufactured module. These modules cost significantly less than new modules and meet the same factory specifications. For more information about the module exchange program, call 1-800-TEK-WIDE, extension 6630.

Module Repair and Return. You may ship your module to us for repair, after which we will return it to you.

New Modules. You may purchase replacement modules in the same way as other replacement parts.

Using the Replaceable Parts List

This section contains a list of the mechanical and/or electrical components that are replaceable for the <instrument>. Use this list to identify and order replacement parts. The following table describes each column in the parts list.

Parts List Column Descriptions

Column	Column Name	Description
1	Figure & Index Number	Items in this section are referenced by figure and index numbers to the exploded view illustrations that precede the list
2	Tektronix Part Number	Use this part number when ordering replacement parts from Tektronix
3 and 4	Serial Number	Column three indicates the serial number at which the part was first effective. Column four indicates the serial number at which the part was discontinued. No entries indicates the part is good for all serial numbers
5	Qty	This indicates the quantity of parts used
6	Name & Description	An item name is separated from the description by a colon (:). Because of space limitations, an item name may sometimes appear as incomplete. Use the U.S. Federal Catalog handbook H6-1 for further item name identification
7	Mfr. Code	This indicates the code of the actual manufacturer of the part
8	Mfr. Part Number	This indicates the actual manufacturer's or vendor's part number

Abbreviations Abbreviations conform to American National Standard ANSI Y1.1-1972.

Mfr. Code to Manufacturer Cross Index

The table titled Manufacturers Cross Index shows codes, names, and addresses of manufacturers or vendors of components listed in the parts list.

Manufacturers cross index

Mfr. code	Manufacturer	Address	City, state, zip code
00779	AMP INC.	CUSTOMER SERVICE DEPT PO BOX 3608	HARRISBURG, PA 17105-3608
060D9	UNITREK CORPORATION	3000 COLUMBIA HOUSE BLVD, SUITE 1 20	VANCOUVER, WA 98661
07416	NELSON NAME PLATE COMPANY	3191 CASITAS AVENUE	LOS ANGELES, CA 90039-2410
0APF4	U S PRECISION GLASS	1900 HOLMES ROAD	ELGIN, IL 60123
0GV52	SCHAFFNER EMC INC	9-B FADEM ROAD	SPRINGFIELD, NJ 07081
0J9P9	GEROME MFG CO INC	PO BOX 737 403 NORTH MAIN	NEWBERG, OR 97132
0KB01	STAUFFER SUPPLY CO	810 SE SHERMAN	PORTLAND, OR 97214-4657
0KB05	NORTH STAR NAMEPLATE INC	5750 NE MOORE COURT	HILLSBORO, OR 97124-6474
1DM20	PARLEX CORP	7 INDUSTRIAL WAY	SALEM, NH 03079
24931	FCI USA INC	RF/COAXIAL DIV 2100 EARLYWOOD DR PO BOX 547	FRANKLIN, IN 46131
31918	ITT SWITCH PRODUCTS	8081 WALLACE RD	EDEN PRAIRIE, MN 55344-8798
32997	BOURNS INC	TRIMPOT DIVISION 1200 COLUMBIA AVE	RIVERSIDE, CA 92507-2114
50356	TEAC AMERICA INC	7733 TELEGRAPH RD PO BOX 750	MONTEBELLO, CA 90640-6537
55322	SAMTEC INC	810 PROGRESS BLVD PO BOX 1147	NEW ALBANY, IN 47150-1147
7X318	KASO PLASTICS INC	5720-C NE 121ST AVE, STE 110	VANCOUVER, WA 98682
80009	TEKTRONIX INC	14150 SW KARL BRAUN DR PO BOX 500	BEAVERTON, OR 97077-0001
86928	SEASTROM MFG CO INC	456 SEASTROM STREET	TWIN FALLS, ID 83301
TK00J	NEC AMERICA INC.	10900 N E 8TH ST SUITE 1208	BELLEVUE, WA 98004
TK1163	POLYCAST INC	9898 SW TIGARD ST	TIGARD, OR 97223
TK1326	NORTHWEST FOURSLIDE INC	13945 SW GALBREATH DR	SHERWOOD, OR 97140
TK1955	ARTESYN TECHNOLOGIES	47173 BENICIA ST	FREMONT, CA 94538 -7331
TK2376	CONDUCTIVE RUBBER TECH	22125 17TH AVE SE, SUITE 117	BOTHELL, WA 98021
TK2548	XEROX CORPORATION	14181 SW MILLIKAN WAY	BEAVERTON, OR 97005
TK6179	VISION PLASTICS, INC.	26000 SW PARKWAY CENTER DRIVE	WILSONVILLE, OR 97070
TK2647	INSTRUMENT SPECIALTIES CO INC.	C/O TEMCO NW 1336 SE 51ST STREET	HILLSBORO, OR 97123
TK6085	OXFORD WIRE & CABLE SERVICE INC	10 INDUSTRIAL DR	OXFORD, MS 38655
TK6179	SPM/DYNACAST	22990 NW BENNETT ST	HILLSBORO, OR 97124-5890

Exploded Views Figures 10-1 through 10-5 on the following pages show the module-level exploded views of the TDS3000B series oscilloscope. The adjacent page is the list of components for that exploded view, indexed by the numbers in the figure.

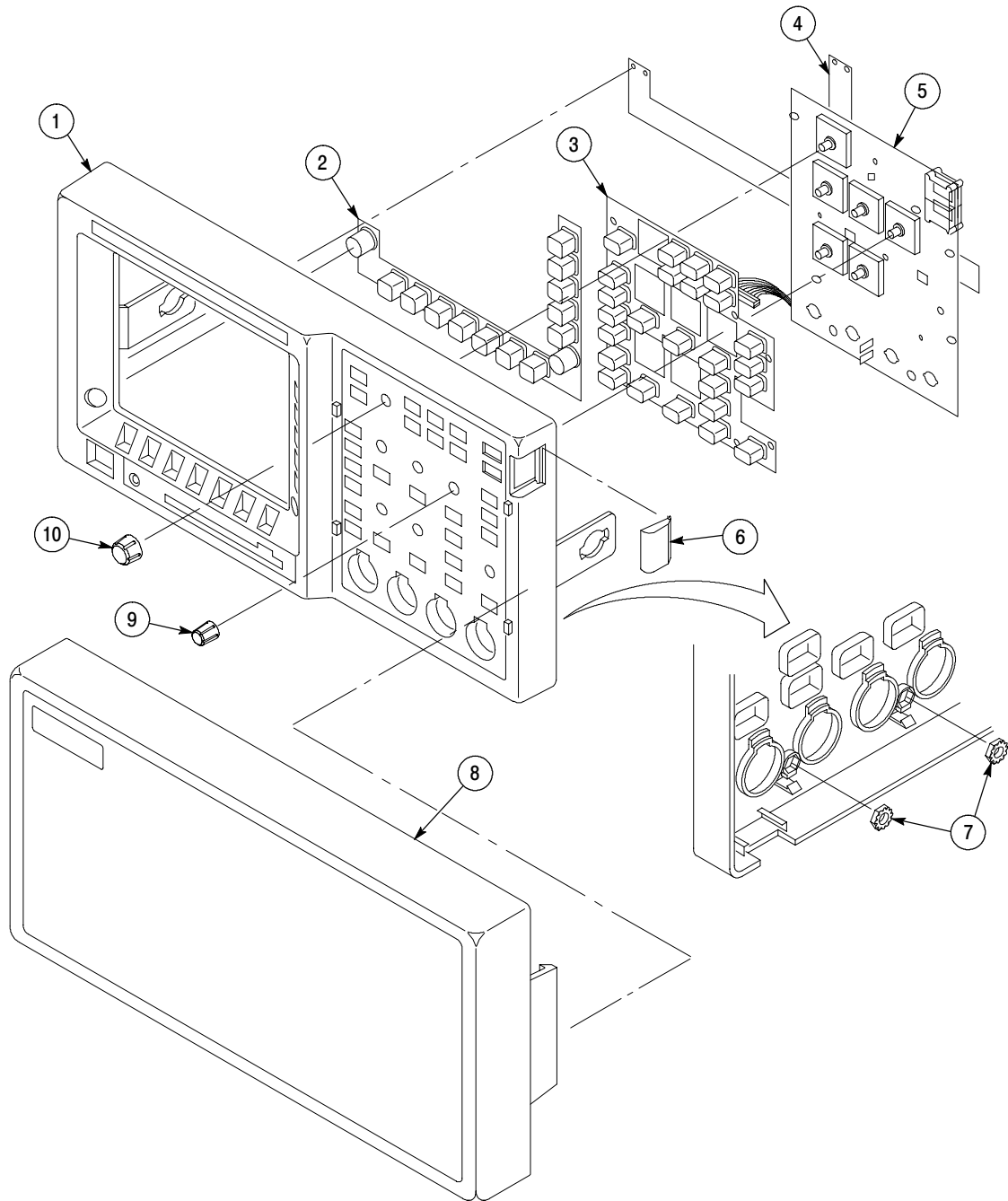

Figure 10-1: Exploded view, front case half

Replaceable parts list

Fig. & index number	Tektronix part number	Serial no. effective	Serial no. discount'd	Qty	Name & description	Mfr. code	Mfr. part number
10-1-1	050-3512-XX			1	PARTS REPL KIT:2 CHANNEL FRONT CASE ASSY,W/LABELS,TDS3012B/TDS3032B/TDS3052B	80009	050-3512-XX
	050-3513-XX			1	PARTS REPL KIT:4 CHANNEL FRONT CASE ASSY,W/LABELS,TDS3014B/TDS3034B/TDS3054B	80009	050-3513-XX
10-1-2	260-2696-00			1	SWITCH,KEYPAD:SILICONE RUBBER,EMAT SET,BEZEL	TK2376	260-2696-00
10-1-3	260-2703-00			1	SWITCH,KEYPAD:ELASTOMERIC,FRONT PANEL,PUSHBUTTON,2 CH	TK2376	260-2703-00
	260-2695-00			1	SWITCH,KEYPAD:ELASTOMERIC,FRONT PANEL,PUSHBUTTON,4 CH	TK2376	260-2695-00
10-1-4	259-0149-00			1	FLEX CIRCUIT:BEZEL BUTTONS,POLYESTER	07416	259-0149-00
10-1-5	679-4119-XX			1	CKT BD SUBASSY:OEM FRONT PANEL	32997	3777S-TEK-010
10-1-6	380-1127-00			2	HOUSING,FRONT:OPTION KEY,PC/ABS,FR110,SILVER GREY	7X318	380-1127-00
10-1-7	210-0457-00			2	NUT,PL,ASSEM WA:6-32 X 0.312,STL CD PL,W/LOCKWASHER	0KB01	ORDER BY DESCRIPTION
10-1-8	200-4416-00			1	COVER:FRONT,PROTECTIVE,13.850 X 7.090 X 2.050,PC/ABS,FR110,BLUE	7X318	200-4416-00
10-1-9	366-0772-00			4	KNOB,CAP:PC/ABS BAYBLEND FR110,SIVER GRAY,0.425 DIA X 0.520 H	TK1163	366-0772-00
10-1-10	366-0771-00			3	KNOB,CAP:PC/ABS BAYBLEND FR110,SILVER GRAY,0.650 DIA X 0.520 H	TK1163	366-0771-00

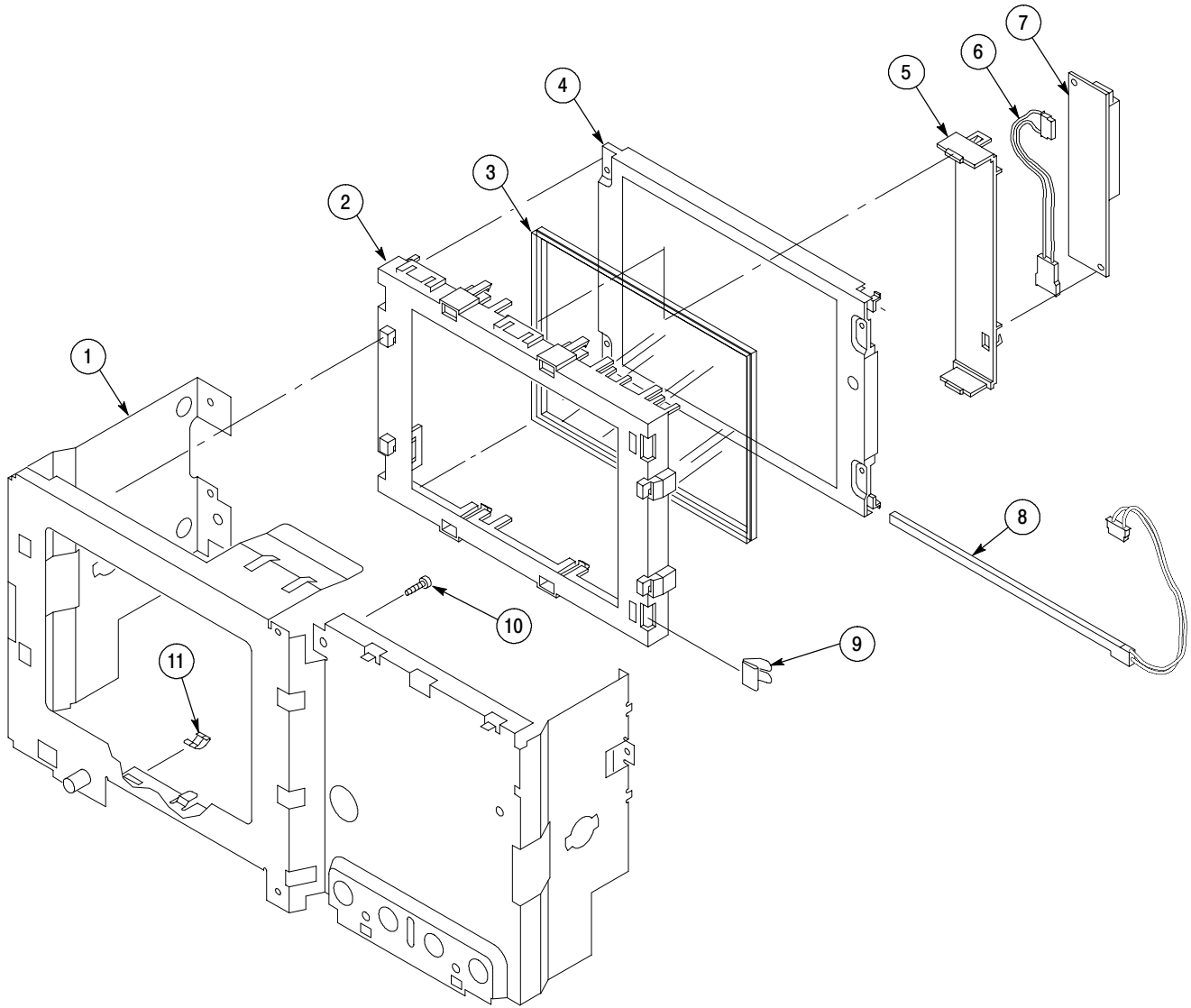

Figure 10-2: Exploded view, LCD display

Replaceable parts list

Fig. & index number	Tektronix part number	Serial no. effective	Serial no. discount'd	Qty	Name & description	Mfr. code	Mfr. part number
10-2-1	441-2144-01			1	CHASSIS:FRONT,0.050 AL,13.020 X 2.860	0J9P9	441-2144-01
10-2-2	380-1117-00			1	HOUSING,DISPLAY:LCD CARRIER,POLY/ABS	TK6179	380-1117-00
10-2-3	337-4148-XX			1	SHIELD,ASSY:DISPLAY,5.950 X 4.600, GLASS	0APF4	337-4148-XX
10-2-4	119-6603-00			1	DISPLAY MODULE:LCD,COLOR,640 X 480,6.5 DIAG,TFT,6-BIT,0.2 MM PIXEL PITCH	80009	119-6603-00
10-2-5	407-4536-00			1	BRACKET,PCB:BACKLIGHT BOARD,1.1330 X 5.4120 X 1.150,POLY/ABS ALLOY BAYBLEND FR-110	TK6179	407-4536-00
10-2-6	174-3827-00			1	CA ASSY,SP:DESCRETE, BACKLIGHT, 22 AWG, 3.5 L, 2X1,0.157 CTR, FEMALE, JST BHR-03VS-1 X	060D9	174-3827-00
10-2-7	119-5999-00			1	POWER SUPPLY:INVERTOR BOARD, REPLACEMENT FOR LCD 119-5659-00 6.5" LCD	TK00J	65PWB31
10-2-8	119-5998-00			2	LAMP:CCFL,REPLACEMENT FOR LCD 119-5659-00 6.5" LCD,W/LEADS	TK00J	65LHS-3L
10-2-9	131-6521-00			4	CONTACT,ELEC:EMI,CLIP-ON,0.38 L X 0.500 W (2 CONTACTS) X 0.45 HIGH,ELECTROLESS NICKEL PLATE	TK2647	9760718005
10-2-10	211-0927-00			2	SCREW,PT:K35-1.57 X 10.0MM,T10,STL,BLACK	0KB01	K35-1.57 X 10 PN PT STL/BLK
10-2-11	131-6643-00			2	CONTACT,ELEC:GROUNDING,0.169 L,0.320 DEEP,ELECTROLESS NICKEL,TDS3012	TK2647	131-6643-00

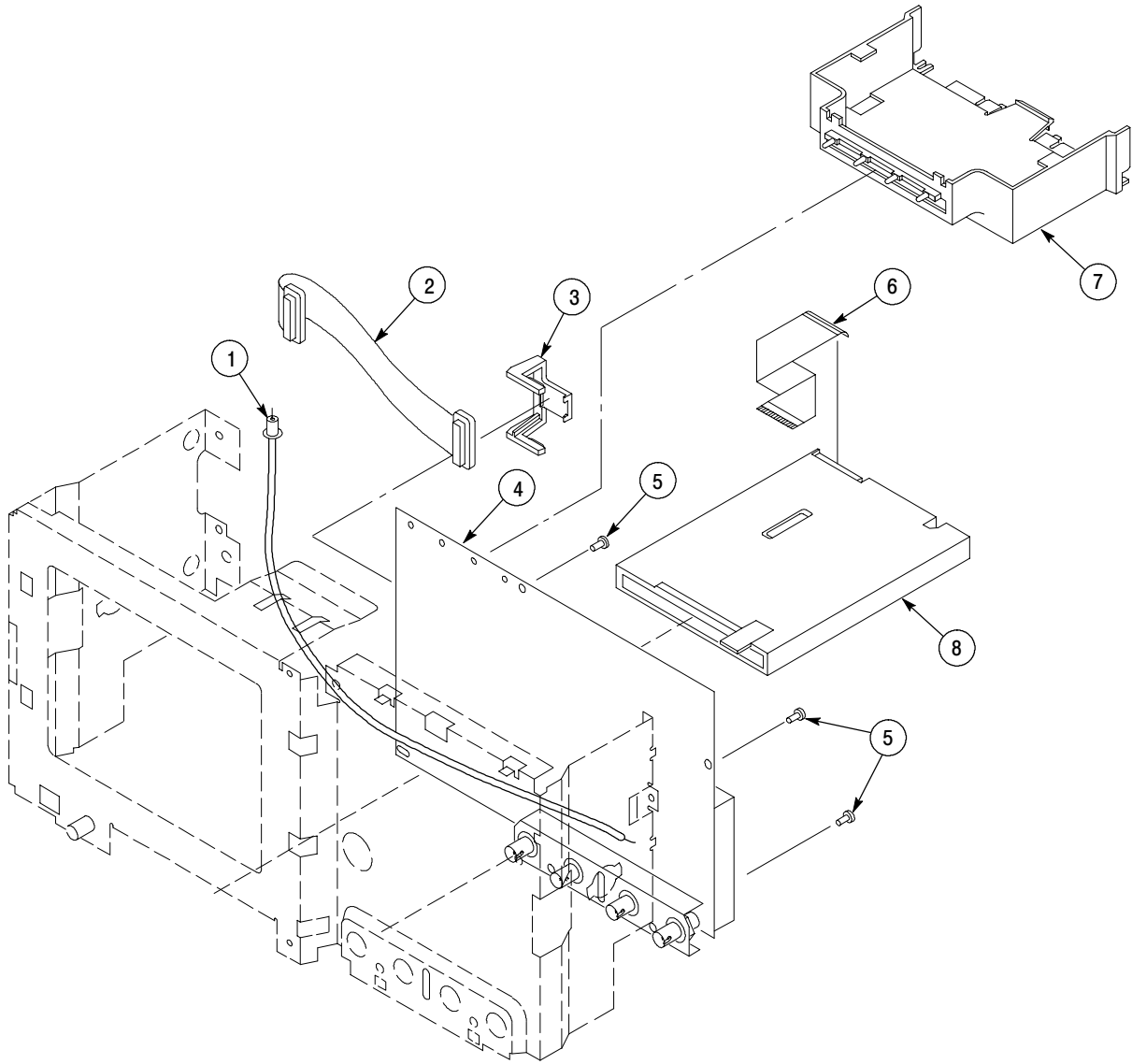

Figure 10-3: Exploded view, main board and disk drive

Replaceable parts list

Fig. & index number	Tektronix part number	Serial no. effective	Serial no. discont'd	Qty	Name & description	Mfr. code	Mfr. part number
10-3-1	174-4536-XX			1	CA ASSY,SP:RF,50 OHM PELTOLA,EXTERNAL TRIGGER (4-channel models only)	060D9	174-4536-XX
10-3-2	174-4610-XX			1	CA ASSY, SP:FLEX,DISPLAY,FLX,33 AWG,0.5MM CTR,5.0 L,TIN/LEAD PLATED CONDUCTORS X 31 POS,LCD	060D9	174-4610-XX
10-3-3	343-1676-XX			1	CLAMP, CABLE; PC/ABS ALLOY, BAYER, BAYBLEND FR-110 SILVER GREY	TK2565	343-1676-XX
10-3-4	671-5430-XX	B010100	B019999	1	CIRCUIT BD ASSY:MAIN BD,2CH, 100MHZ,TDS3012B	80009	671-5430-XX
	671-6014-XX	B020000		1	CIRCUIT BD ASSY:MAIN BD,2CH, 100MHZ,TDS3012B	80009	671-6014-XX
	671-5325-XX	B010100	B019999	1	CIRCUIT BD ASSY:MAIN BD,2 CH, 300 MHZ,TDS3032B	80009	671-5325-XX
	671-6006-XX	B020000		1	CIRCUIT BD ASSY:MAIN BD,2 CH, 300 MHZ,TDS3032B	80009	671-6006-XX
	671-5485-XX	B010100	B019999	1	CIRCUIT BD ASSY:MAIN BD,2 CH, 500 MHZ,TDS3052B	80009	671-5485-XX
	671-6002-XX	B020000		1	CIRCUIT BD ASSY:MAIN BD,2 CH, 500 MHZ,TDS3052B	80009	671-6002-XX
	671-5431-XX	B010100	B019999	1	CIRCUIT BD ASSY:MAIN BD,4 CH, 100 MHZ,TDS3014B	80009	671-5431-XX
	671-6015-XX	B020000		1	CIRCUIT BD ASSY:MAIN BD,4 CH, 100 MHZ,TDS3014B	80009	671-6015-XX
	671-5326-XX	B010100	B019999	1	CIRCUIT BD ASSY:MAIN BD,4 CH, 300 MHZ,TDS3034B	80009	671-5326-XX
	671-6009-XX	B020000		1	CIRCUIT BD ASSY:MAIN BD,4 CH, 300 MHZ,TDS3034B	80009	671-6009-XX
	671-5486-XX	B010100	B019999	1	CIRCUIT BD ASSY:MAIN BD,4 CH, 500 MHZ,TDS3054B	80009	671-5486-XX
	671-6013-XX	B020000		1	CIRCUIT BD ASSY:MAIN BD,4 CH, 500 MHZ,TDS3054B	80009	671-6013-XX
10-3-5	211-0721-00			4	SCREW,MACHINE:6-32 X 0.375,PNH,STL,CDPL,T-15 TORX DR	0KB01	ORDER BY DESCRIPTION
10-3-6	174-3763-02			1	CABLE ASSY,SP:FLEX,FLOPPY DRIVE,FLX,26,1MM,3.600 L,TIN/LEAD PLATED COPPER CONDUCTORS BOTH ENDS	1DM20	174-3763-00
10-3-7	351-1025-00			1	GUIDE:OPTION MODULE,POLY,ABS ALLY,BAYBLEND FR-110	TK6179	351-1025-00
10-3-8	119-6106-00			1	DISK DRIVE:FLOPPY,3.5 INCH,1.44MB	50356	FD-04HF-2300

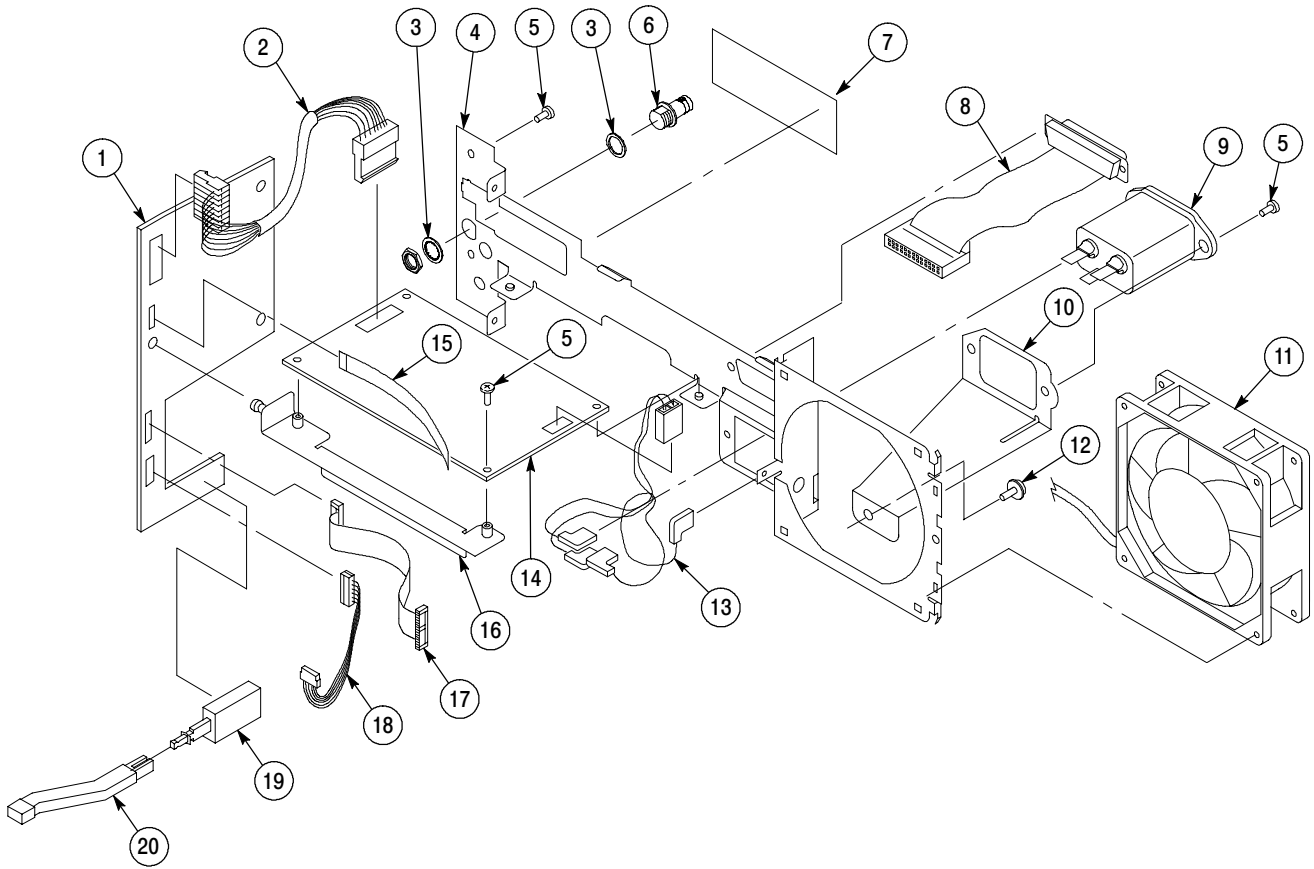

Figure 10-4: Exploded view, circuit board assembly and fan

Replaceable parts list

Fig. & index number	Tektronix part number	Serial no. effective	Serial no. discont'd	Qty	Name & description	Mfr. code	Mfr. part number
10-4-1	050-3550-XX	B000100	B011560	1	BATTERY BOARD REPLACEMENT KIT [TDS3012B]	80009	050-3550-XX
	671-5363-XX	B011561		1	CKT BD ASSY: BATTERY	80009	671-5363-XX
	050-3550-XX	B000100	B015401	1	BATTERY BOARD REPLACEMENT KIT [TDS3032B]	80009	050-3550-XX
	671-5363-XX	B015402		1	CKT BD ASSY: BATTERY	80009	671-5363-XX
	050-3550-XX	B000100	B012424	1	BATTERY BOARD REPLACEMENT KIT [TDS3052B]	80009	050-3550-XX
	671-5363-XX	B012425		1	CKT BD ASSY: BATTERY	80009	671-5363-XX
	050-3550-XX	B000100	B014638	1	BATTERY BOARD REPLACEMENT KIT [TDS3014B]	80009	050-3550-XX
	671-5363-XX	B014639		1	CKT BD ASSY: BATTERY	80009	671-5363-XX
	050-3550-XX	B000100	B014123	1	BATTERY BOARD REPLACEMENT KIT [TDS3034B]	80009	050-3550-XX
	671-5363-XX	B014124		1	CKT BD ASSY: BATTERY	80009	671-5363-XX
	050-3550-XX	B000100	B015053	1	BATTERY BOARD REPLACEMENT KIT [TDS3054B]	80009	050-3550-XX
	671-5363-XX	B015054		1	CKT BD ASSY: BATTERY	80009	671-5363-XX
10-4-2	174-4533-00			1	CABLE ASSY. SP; DISCRETE, POWER SUPPLY	060D9	174-4533-00
10-4-3	210-0978-00			2	WASHER, FLAT; 0.375 ID X 0.5 OD X 0.024, STL CD PL	86928	ORDER BY DESCRIPTION
10-4-4	441-2145-01			1	CHASSIS:REAR,0.050 AL,12,795 X 3.620,CHROMATE	0J9P9	441-2145-01
10-4-5	211-0711-00			7	SCREW,MACHINE:6-32 X 0.250,PNH,STL,CDPL,T-15 TORX DR	0KB01	ORDER BY DESCRIPTION
10-4-6	131-1315-01			1	CONN, RF JACK; BNC, PNL; 50 OHM, FEMALE	24931	28JR306-1
10-4-7	335-0519-00			1	MARKER, IDENT; LABEL, COVERUP NO EXT TRIG	0KB05	335-0519-00
10-4-8	174-3765-00			1	CA ASSY,SP:RIBBON,PRINTER,IDC,4.0 L,28 AWG,2X13,0.1CTR,RCPT X 25 POS,DSUB,FEMALE,W/0.120 DI	060D9	174-3765-00
10-4-9	119-0420-00			1	FILTER,RFI:6A,250VAC,400HZ	0GV52	FN323B-6/01
10-4-10	337-4254-00			1	SHIELD, STRAP; FILTER TO ATTENUATOR SHIELD	TK1326	337-4254-00
10-4-11	119-5848-00			1	FAN,DC:TUBEAXIAL,24V,2.09W,2450 RPM,41 CFM,92MM X 25MM,33 DBA,3610KL-05W-B30-P00,	060D9	119-5848-00
10-4-12	211-0967-00			1	SCREW:6-32X 0.25,PNH,STL,ZI PLT,T-15, W/CAPTIVE FLAT WASHER,	0KB01	211-0967-00
10-4-13	174-3764-00			1	CABLE ASSEMBLY:DESCRETE,LINE INPUT SENSE,PSC,3,18 AWG,1,26 AWG,4.5 L,1X3,0.156 CTR,RCPT X 2,0,2	060D9	174-3764-00
10-4-14	119-6823-XX			1	POWER SUPPLY:40W,AC-DC,90-264 VAC IN,15V 2.6A OR 3.3A,20 CFM,NAN40-7615	TK1955	NAN40-7615

Replaceable parts list (cont.)

Fig. & index number	Tektronix part number	Serial no. effective	Serial no. discount'd	Qty	Name & description	Mfr. code	Mfr. part number
10-4-15	174-4606-01			1	CA ASSY, SP; FLAT FLEX, ETHERNET, 9 POS, SHIELDED	1DM20	174-4606-01
10-4-16	407-4530-00			1	BRACKET:POWER SUPPLY SUPPORT,0.050 AL,5.150 X 0.785,CHROMATE	0J9P9	407-4530-00
10-4-17	174-4607-00	B000100	B012691	1	CA ASSY, SP:DUAL ENDED, FEMALE, BATTERY BD TO MAIN [TDS3012B]	55322	174-4607-00
	174-4607-01	B012692		1	CA ASSY, FEMALE, PLZ, BATTERY BD TO MAIN	55322	174-4607-01
	174-4607-00	B000100	B012507	1	CA ASSY, SP:DUAL ENDED, FEMALE, BATTERY BD TO MAIN [TDS3032B]	55322	174-4607-00
	174-4607-01	B012508		1	CA ASSY, FEMALE, PLZ, BATTERY BD TO MAIN	55322	174-4607-01
	174-4607-00	B000100	B011153	1	CA ASSY, SP:DUAL ENDED, FEMALE, STR, 2 X 13, 0.050 CTR, BATTERY BD TO MAIN [TDS3052B]	55322	174-4607-00
	174-4607-01	B011154		1	CA ASSY, FEMALE, PLZ, BATTERY BD TO MAIN	55322	174-4607-01
	174-4607-00	B000100	B012175	1	CA ASSY, SP:DUAL ENDED, FEMALE, STR, 2 X 13, 0.050 CTR, BATTERY BD TO MAIN [TDS3014B]	55322	174-4607-00
	174-4607-01	B012176		1	CA ASSY, FEMALE, PLZ, BATTERY BD TO MAIN	55322	174-4607-01
	174-4607-00	B000100	B012023	1	CA ASSY, SP:DUAL ENDED, FEMALE, BATTERY BD TO MAIN [TDS3034B]	55322	174-4607-00
	174-4607-01	B012024		1	CA ASSY, FEMALE, PLZ, BATTERY BD TO MAIN	55322	174-4607-01
	174-4607-00	B000100	B012408	1	CA ASSY, SP:DUAL ENDED, FEMALE, BATTERY BD TO MAIN [TDS3054B]	55322	174-4607-00
	174-4607-01	B012409		1	CA ASSY, FEMALE, PLZ, BATTERY BD TO MAIN	55322	174-4607-01
10-4-18	174-3767-01			1	CA ASSY, SP; DISCRETE, BACKLIGHT, IDC	TK6085	174-3767-01
10-4-19	260-2443-00			1	SWITCH,PWR:DPDT,PUSH PUSH ALT ACT,PC PINS	31918	NE18-00-EE-N-47-01A (130238)
10-4-20	384-1813-00			1	SHAFT:BAYBLEND FR110,SILVER GREY	TK6179	384-1813-00

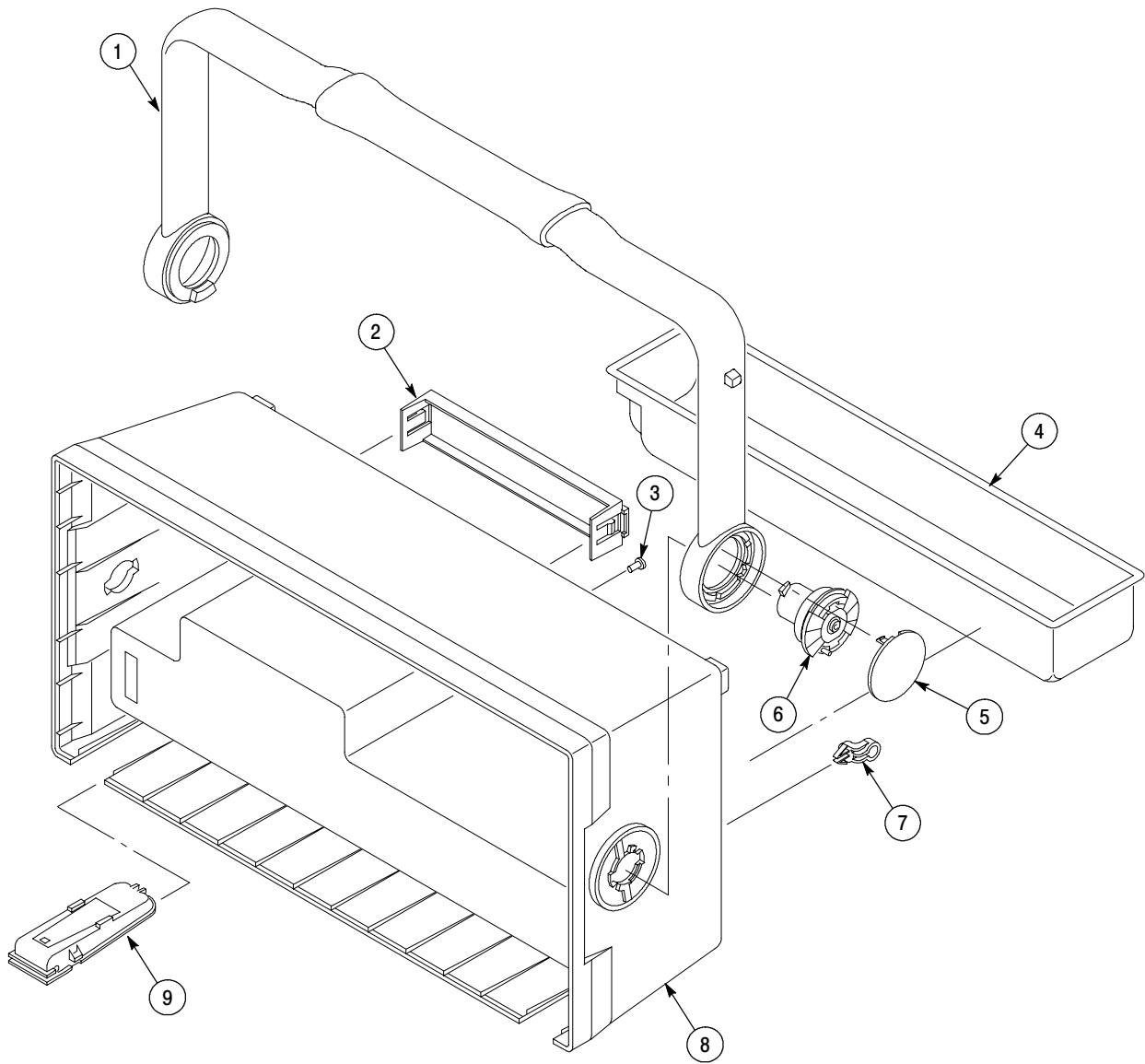

Figure 10-5: Exploded view, rear case half

Replaceable parts list

Fig. & index number	Tektronix part number	Serial no. effective	Serial no. discount'd	Qty	Name & description	Mfr. code	Mfr. part number
10-5-1	367-0498-00			1	HANDLE,CARRYING:14.5740 X 6.3230	7X318	367-0498-00
10-5-2	200-4415-00			1	COVER:OPTION MODULE OPENING,5.1440 X 0.910 X 0.9950,PC/ABS,FR110,BLUE	TK6179	200-4415-00
10-5-3	211-0722-00			1	SCREW,MACHINE:6-32 X 0.250,PNH,STL,CDPL,T-15 TORX DR	0KB01	ORDER BY DESCRIPTION
10-5-4	436-0371-00			1	TRAY,ACCESSORY:BATTERY COMPARTMENT	TK6179	436-0371-00
10-5-5	200-4394-00			2	COVER,HUB:POLY,1.60 DIAMETER	7X318	200-4394-00
10-5-6	401-0785-00			2	HUB ASSY:NYLON	7X318	401-0785-00
10-5-7	343-1213-00			1	CLAMP,PWR CORD:POLYIMIDE	TK1163	ORDER BY DESCRIPTION
10-5-8	050-3514-XX			1	PARTS REPL KIT:REAR CASE,TDS3000B SERIES	80009	050-3514-XX
10-5-9	348-1582-00			2	FOOT ASSY:FRONT,HINGED,HOUSING 380-1118-00,FRONT FOOT 348-1557-00,	7X318	348-1582-00

Accessories list

Fig. & index number	Tektronix part number	Serial no. effective	Serial no. discount'd	Qty	Name & description	Mfr. code	Mfr. part number
	200-4416-00			1	COVER:FRONT,PROTECTIVE (SEE FIGURE 10-1-8)	7X318	200-4416-00
	_____			2	P3010 PASSIVE PROBE,10X,100MHZ,W/ACCY (TDS3012B,TDS3014B ONLY)		ORDER BY DESC
	_____			2	P6139A PASSIVE PROBE,10X,W/ACCY (TDS3032B, TDS3034B, TDS3052B, TDS3054B ONLY)		ORDER BY DESC
	436-0371-00			1	TRAY,ACCESSORY:BATTERY COMPARTMENT	TK6179	436-0371-00
	020-2382-XX			1	MANUAL SET; TDS3000B DOCUMENT KIT, ENGLISH	TK2548	020-2382-XX
	020-2383-XX			1	MANUAL SET; TDS3000B DOCUMENT KIT, FRENCH	TK2548	020-2383-XX
	020-2384-XX			1	MANUAL SET; TDS3000B DOCUMENT KIT, GERMAN	TK2548	020-2384-XX
	020-2385-XX			1	MANUAL SET; TDS3000B DOCUMENT KIT, ITALIAN	TK2548	020-2385-XX
	020-2386-XX			1	MANUAL SET; TDS3000B DOCUMENT KIT, SPANISH	TK2548	020-2386-XX
	020-2387-XX			1	MANUAL SET; TDS3000B DOCUMENT KIT, PORTUGUESE	TK2548	020-2387-XX
	020-2388-XX			1	MANUAL SET; TDS3000B DOCUMENT KIT, KOREAN	TK2548	020-2388-XX
	020-2389-XX			1	MANUAL SET; TDS3000B DOCUMENT KIT, SIMPLIFIED CHINESE	TK2548	020-2389-XX
	020-2390-XX			1	MANUAL SET; TDS3000B DOCUMENT KIT, TRADITIONAL CHINESE	TK2548	020-2390-XX
	020-2391-XX			1	MANUAL SET; TDS3000B DOCUMENT KIT, JAPANESE	TK2548	020-2391-XX
	020-2392-XX			1	MANUAL SET; TDS3000B DOCUMENT KIT, RUSSIAN	TK2548	020-2392-XX

Accessories list (cont.)

Fig. & index number	Tektronix part number	Serial no. effective	Serial no. discont'd	Qty	Name & description	Mfr. code	Mfr. part number
				1	TDS3AAM ADVANCED ANALYSIS APP MODULE		ORDER BY DESC
				1	TDS3LIM LIMIT TEST APP MODULE		ORDER BY DESC
				1	TDS3SDI 601 DIGITAL VIDEO APP MODULE		ORDER BY DESC
				1	TDS3TRG ADVANCED TRIGGER APP MODULE		ORDER BY DESC
				1	TDS3FFT FFT APPLICATION MODULE		ORDER BY DESC
				1	TDS3TMT TELECOM MASK TEST APP MODULE		ORDER BY DESC
				1	TDS3VID EXTENDED VIDEO APP MODULE		ORDER BY DESC
				1	TDS3GV GPIB/RS232/VGA COMM MODULE		ORDER BY DESC
				1	TDS3CHG EXTERNAL BATT CHARGER		ORDER BY DESC
				1	TDS3BATB BATTERY PACK		ORDER BY DESC
				1	AC3000 OSC SOFT CARRY CASE		ORDER BY DESC
				1	RM3000 RACK MOUNT KIT		ORDER BY DESC
				1	AD007 GPIB TO LAN ADAPTER		ORDER BY DESC
				1	WSTRO WAVESTAR SOFTWARE FOR OSC		ORDER BY DESC
	071-0972-XX			1	MANUAL,TECH: SERVICE,TDS3000B SERIES	TK2548	071-0972-XX

