



Advanced Test Equipment Rentals
www.atecorp.com 800-404-ATEC (2832)

INSTRUCTION MANUAL

Digital Electrometer

Model 616

COPYRIGHT 1975 KEITHLEY INSTRUMENTS, INC.

NINTH PRINTING, FEBRUARY, 1980, CLEVELAND, OHIO, U. S. A.

DOCUMENT NO. 28039

CONTENTS

<u>Section</u>	<u>Page</u>
SPECIFICATIONS -----	iv
1. GENERAL INFORMATION -----	1
2. INITIAL PREPARATION -----	4
3. OPERATING INSTRUCTIONS -----	5
4. THEORY OF OPERATION -----	21
5. ACCESSORIES -----	29
6. MAINTENANCE -----	33
7. REPLACEABLE PARTS -----	37
SCHEMATICS -----	61

ILLUSTRATIONS

Figure No.	Title	Page No.
1	Front Panel	1
2	Front Panel Controls	2
3	Rear Panel Connectors	3
4	Triaxial Input	5
5	Typical Display on 10mV Sensitivity	5
6	Operation as a Voltmeter in NORMAL Mode	7
7	Operation as an Ammeter in NORMAL Mode	8
8	Loading Effects in Ammeter Function	8
9	Operation as an Ohmmeter in NORMAL Mode	10
10	Operation as a Coulombmeter in FAST Mode	11
11	Null Method for Current Measurement	12
12	Volt-Ammeter Resistance Method	12
13	Unity Gain (X1) Measurement	12
14	Use of IV Recorder Output	12
15	Front Panel of Model 6162	13
16	Dual Rack Mounting Using Model 1007 Hardware	13
17	Rear Panel of Model 616 and 6162	14
18	Diagram of Interconnection Cable between 616 and 6162	14
19	Identification of Pins on Digital Output Connector	16
20	Suggested Hook-up for Data Lines	18
21	Block Diagram of 616/6162 System	19
22	Timing Diagram for 6162 Outputs	19
23	Overall Block Diagram of Model 616	21
24	Simplified Diagram of Amplifier Section	22
25	Voltmeter Configuration - NORMAL Mode	23
26	Ammeter Configuration - FAST Mode	23
27	Coulombmeter Configuration - FAST Mode	24
28	Ohmmeter Configuration - NORMAL Mode	24
29	Functional Block Diagram of A-to-D Converter	25
30	Functional Block Diagram of Large Scale Integrated Circuit	26
31	Digital Display	26
32	Chassis Assembly - Exploded View	39
33	Bottom Cover Assembly	39
34	Component Layout, PC-321	53
35	Component Layout, PC-335	54
36	Component Layout, PC-322	55
37	Component Layout, PC-323	57
38	Component Layout, PC-324	59
39	Component Layout, PC-325	60

SPECIFICATIONS

AS AN AUTORANGING VOLTMETER

RANGE: ± 10 microvolts per digit (10mV full range) to ± 100 volts full range in five decade ranges. 100% overranging to 1999 on all ranges.

ACCURACY (20°C to 30°C): $\pm(0.2\%$ of reading $+0.1\%$ of range).

READING TIME: Less than 4 seconds to within 0.1% of final reading, except where limited by source characteristics.

ZERO DRIFT: Less than (50 microvolts $+0.01\%$ of range) per °C, and less than 100 microvolts per 24-hour period after two hours warm-up (during which drift does not exceed 500 microvolts).

NOISE: ± 10 microvolts with input shorted.

INPUT IMPEDANCE: Greater than 2×10^{14} ohms shunted by 20 picofarads. Input resistance may also be selected in decade steps from 10 to 10^{11} ohms.

NORMAL MODE REJECTION RATIO:

RANGE	NMRR	MAX. AC
10mV	94dB	2V p-p
100mV	80dB	2V p-p
1 V	80dB	20V p-p
10 V	60dB	20V p-p
100 V	60dB	200V p-p

For voltage of line frequency and at least 10% of full range dc reading. Maximum total input 200 volts peak ac + dc.

COMMON MODE REJECTION RATIO: Greater than 140 dB at line frequency with 300 volts peak-to-peak from circuit Lo to chassis ground, up to 10^{11} ohm source resistance, and at least 10% of full range dc reading.

AS AN AMMETER

RANGE: $\pm 10^{-16}$ ampere per digit (10^{-13} ampere full range) to ± 0.1 ampere full range in 13 decade ranges. 100% overranging to 1999 on all ranges.

ACCURACY (20°C to 30°C):

Range Switch Setting	Accuracy
10^{-1} to 10^{-7} A	$\pm(0.5\%$ of reading $+0.1\%$ of range)
10^{-8} A	$\pm(2\%$ of reading $+0.1\%$ of range)
10^{-9} to 10^{-11} A	$\pm(5\%$ of reading $+0.1\%$ of range)

NOISE: 2×10^{-15} ampere peak-to-peak on the most sensitive range, exclusive of alpha particle disturbance.

OFFSET CURRENT: Less than 5×10^{-15} ampere.

COMMON MODE REJECTION: 300 volts peak-to-peak at line frequency from circuit Lo to chassis ground on any range and with at least 10% of full range dc reading will not degrade accuracy more than 0.3% of range. (Equivalent to 140 dB CMRR).

AS AN OHMMETER

RANGE: 1 ohm per digit (1000 ohms full range) to 10^{14} ohms full range in 12 decade ranges. 100% overranging to 1999 on all ranges.

ACCURACY (20°C to 30°C):

Range Switch Setting	Accuracy
10^5 to $10^7\Omega$	$\pm(0.5\%$ of reading $+0.1\%$ of range)
$10^8\Omega$	$\pm(2\%$ of reading $+0.1\%$ of range)
10^9 to $10^{12}\Omega$	$\pm(5\%$ of reading $+0.1\%$ of range)

METHOD: Two-terminal constant-current. Current equals reciprocal of OHMS range.

AS A COULOMB METER

RANGE: $\pm 10^{-15}$ coulomb per digit (10^{-12} coulomb full range) to $\pm 10^{-5}$ coulomb full range in 8 decade ranges. 100% overranging to 1999 on all ranges.

ACCURACY (20°C to 30°C): $\pm(5\%$ of reading $+0.1\%$ of range) on all ranges.

AS A CONSTANT CURRENT SOURCE

RANGE: 8 currents in decade steps from 10^{-5} to 10^{-12} ampere using OHMS ranges. Hi terminal is positive.

COMPLIANCE: Up to 200 volts.

ACCURACY (20°C to 30°C): $\pm 0.5\%$ from 10^{-5} to 10^{-7} ampere. $\pm 2\%$ at 10^{-8} ampere. $\pm 5\%$ from 10^{-9} to 10^{-12} ampere.

LOAD REGULATION: Better than 0.1% for loads up to 10^{11} ohms.

GENERAL

DISPLAY: 3 digits plus 1 overrange digit; decimal position, polarity, and overload indication; 5 readings per second. Depending on sensitivity setting, 3 least-significant digits blink or blank when overload condition exists.

POLARITY SELECTION: Automatic

SENSITIVITY SELECTION: Automatic: Voltage sensitivity selection is fully automatic. Sensitivity selection is automatic two decades above and below range switch setting for resistance, charge, and most current measurements. Manual: Front panel switch. Remote: Programmable with the Model 6162 Output/Control (optional).

ISOLATION: Circuit Lo to chassis ground; greater than 10^9 ohms shunted by 500 picofarads (decreasing to 10^8 ohms at 30°C and 70% relative humidity). Circuit Lo may be floated up to ± 1000 volts with respect to chassis ground.

ANALOG OUTPUTS: Unity Gain: For dc inputs, output is equal to input within 20 ppm for output currents of 1mA or less. In the fast mode output polarity is opposite input polarity. 1 volt: ± 1 volt at up to 1mA with respect to circuit Lo for full range input; 100% overrange capability. In the normal mode the output polarity is opposite input polarity.

OPERATING ENVIRONMENT: 20°C to 30°C, 0% to 70% relative humidity. 10°C to 50°C with derated specifications. Storage: 0°C to 70°C.

CONNECTORS: Input: Teflon-insulated triaxial.

Analog Outputs: Unity gain, 1 volt chassis, Lo, and guard; binding posts. BCD Output: Internal connectors for interfacing the Model 6162 Isolated Output/Control.

DIMENSIONS; WEIGHT: Style M 3-1/2 in. half-rack, overall bench size 4 in. high x 8-3/4 in. wide x 15-3/4 in. deep (100 x 220 x 400 mm); net weight, 11 pounds (4,8 kg).

POWER: Line Operation: 90-125 or 180-250 volts (switch selected), 50-60 Hz, 9 watts.

ACCESSORIES SUPPLIED: Model 6011 Input Cable: 3 ft. (1m) triaxial cable with triaxial connector and 3 alligator clips.

NOTE: All accuracy and gain specifications are exclusive of noise and zero offsets. Accuracies include temperature coefficient. On the 5% accuracy ranges as an Ammeter, Ohmmeter, and Constant Current Source the coefficient is less than 0.2% per °C.

SECTION 1. GENERAL INFORMATION

1-1. INTRODUCTION. The Model 616 Digital Electrometer is an automatic ranging, multipurpose electrometer featuring sensitivity to 10 microvolts per digit. Its 3-1/2 digit LED display provides 0.2% voltage accuracy for a wide range of measurements. The Model 616 is essentially a digital multimeter optimized for measurements from high source impedance. The 616 provides wide range capability when measuring current, resistance, and charge in addition to voltage.

1-2. WARRANTY INFORMATION. The warranty is stated on the inside front cover of the manual.

1-3. CHANGE NOTICE. Improvements or changes to the instrument not incorporated into the manual will be explained on a Change Notice Sheet attached to the inside back cover.

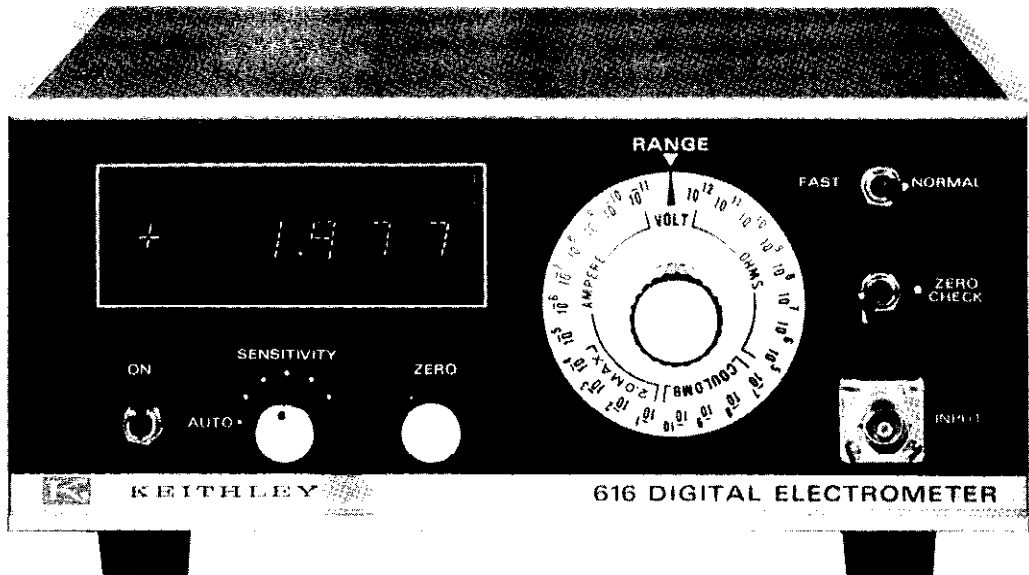

TABLE 1-1.
Front Panel Controls

Control	Functional Description	Paragraph
Power ON	Controls line power.	--
SENSITIVITY	Sets voltage sensitivity and decimal point.	3-4a
ZERO	Adjusts zero offset.	3-4a
RANGE	Sets range on a chosen function.	3-3
FAST/NORMAL	Sets instrument for either Feedback or Shunt Mode.	3-7b
ZERO CHECK	Places instrument in ZERO CHECK mode.	3-6
INPUT	Triaxial input receptacle.	3-2a

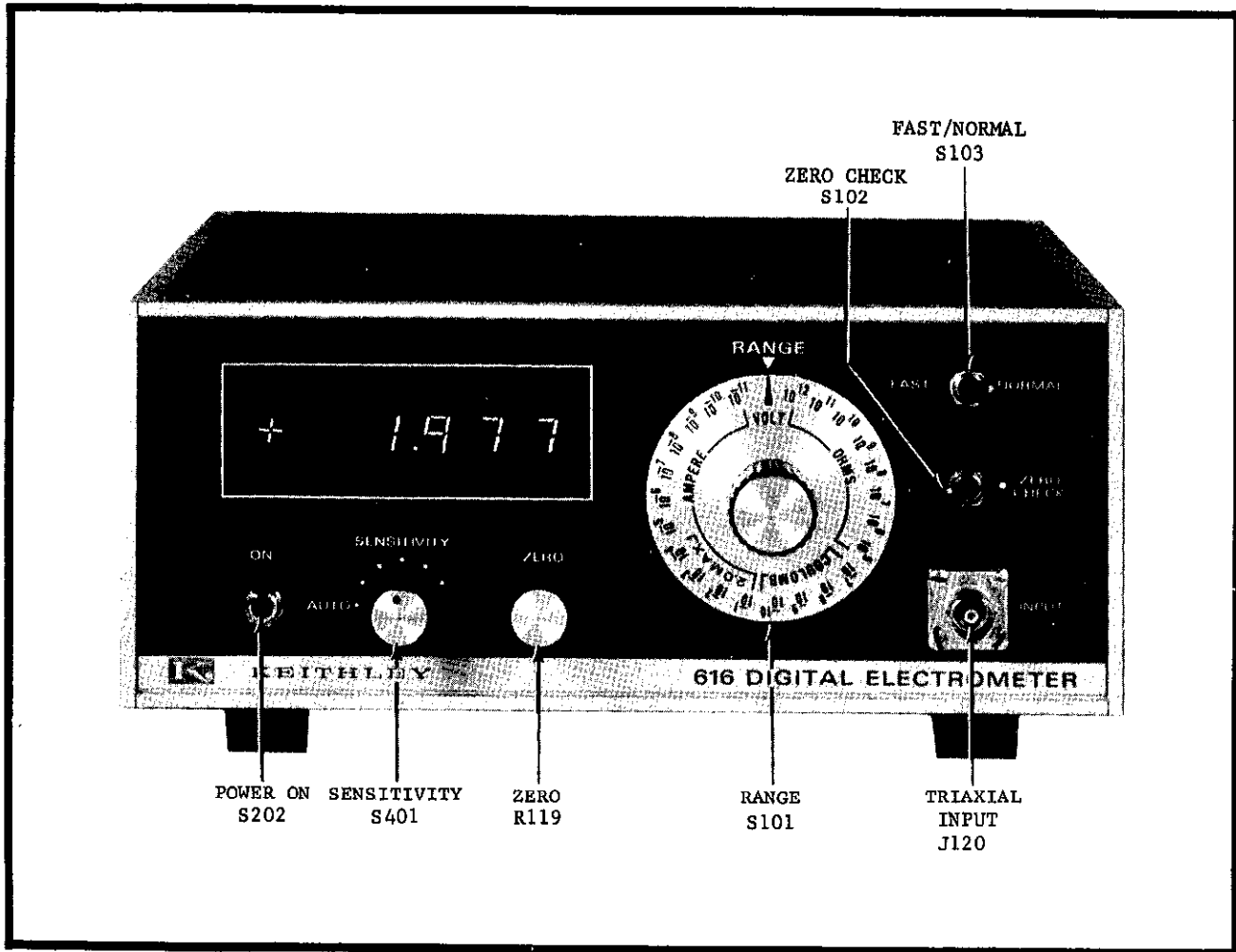

FIGURE 2. Front Panel Controls and Display.

TABLE 1-2.
Rear Panel Controls.

Control		Functional Description	Paragraph
Line Switch	S201	Sets instrument for nominal 117V or 234V.	2-3a
Line Receptacle	P201	Mates with 3-wire line cord.	2-3c
FUSE	F201	117V: 3/16A (FU-29) 234V: 1/10A (FU-40)	2-3b
X1 (WHITE)	J118	Unity-gain Output, 200V @ 1 mA maximum.	3-2c
1V (RED)	J117	Recorder Output, 1V @ 1 mA full range.	3-2c
GUARD (BLUE)	J121	Guard Output.	3-2c
LO (BLACK)	J122	Circuit Low.	3-2c
GROUND (GREEN)	J123	Chassis ground.	3-2c

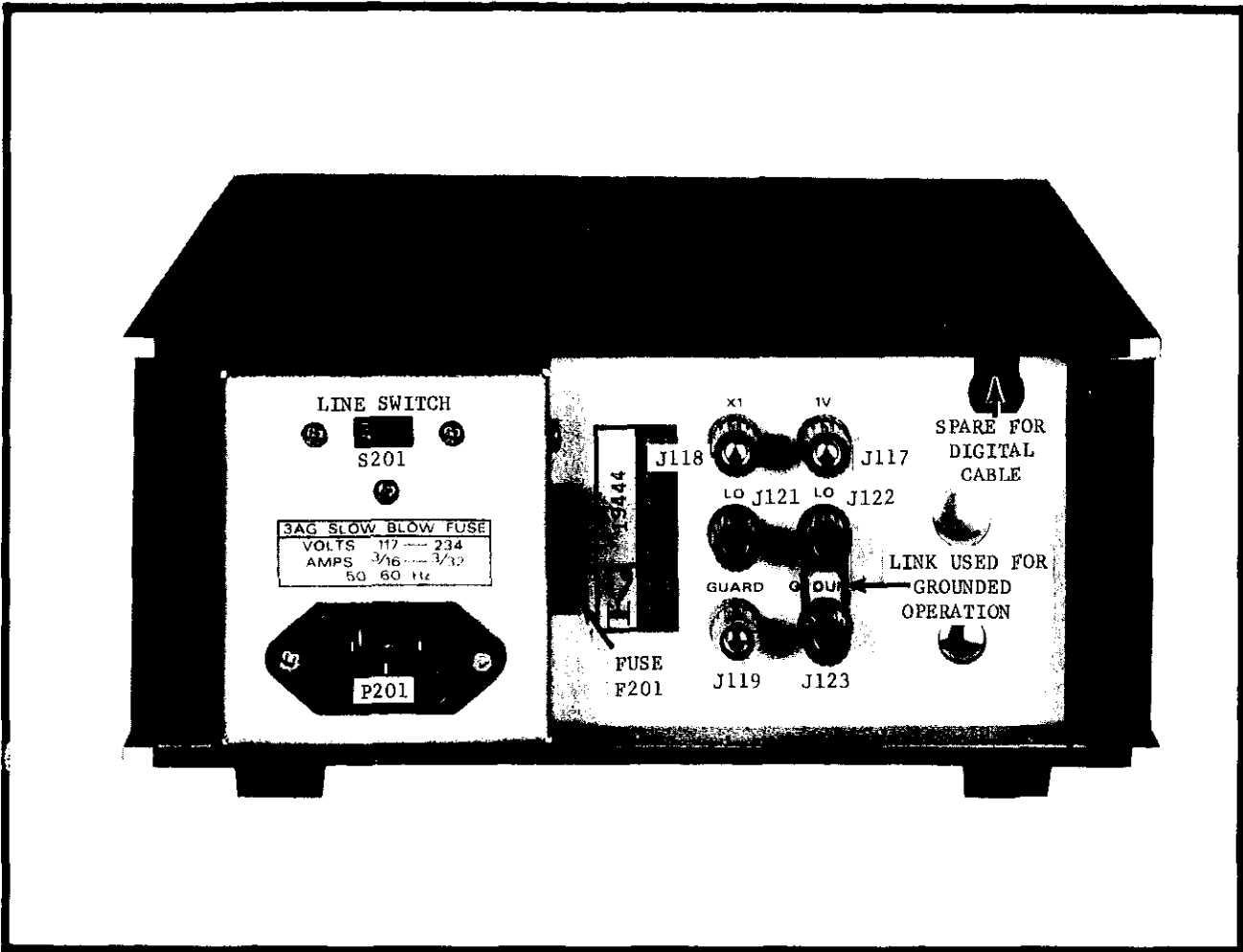

FIGURE 3. Rear Panel Connectors.

SECTION 2. INITIAL PREPARATION

2-1. GENERAL. This section describes procedures for incoming inspection and preparation for use.

2-2. INSPECTION. The Model 616 was carefully inspected both mechanically and electrically before shipment. Upon receiving the instrument, check for any obvious damage which may have occurred during transit. Report any damages to the shipping agent.

2-3. PREPARATION FOR USE.

a. Line Voltage. Before power is applied check the position of the LINE switch (S201) on the rear panel. Select the 117V position for operation from 50-60 Hz line voltages over the range 90V to 125V rms. Select the 234V position for operation from 50-60 Hz line voltages over the range 180V to 250V rms. Line voltages which are not covered by ranges specified require an appropriate step-up or step-down power transformer.

b. Fuse Installation. After the line voltage range is selected check for the proper fuse type and rating as follows:

117V: 3/16 ampere, type 3AG SLO-BLO (FU-29)

234V: 1/10 ampere, type 3AG SLO-BLO (FU-40)

c. Line Connections. This instrument requires a three-wire line cord (Keithley part no. CO-7) which provides connections to line voltage (high, common) and chassis ground. For operator safety, the chassis ground pin should be connected to earth ground.

CAUTION

If the instrument input LO is to be floated, above chassis ground, make certain that the "link" between LO and GROUND on the rear panel is removed.

d. Warm-up. The recommended warm-up time for the Model 616 is two hours, although it is useable immediately after power is turned on, for less critical measurements.

SECTION 3. OPERATING INSTRUCTIONS

3-1. GENERAL. This section describes the procedures for operating the Model 616 for measurement of voltage, current, charge, and resistance.

3-2. HOW TO MAKE INPUT AND OUTPUT CONNECTIONS.

a. Input Receptacle. This receptacle is a Teflon insulated triaxial connector. The center terminal is the high impedance input; the inner shield is the low input; and the outer shield is case ground. The mating connector is a Keithley part no. CS-141 triaxial plug.

b. Model 6011 Input Cable. This cable is a 30 inch long triaxial cable terminated with 3 color-coded alligator clips. The input high is identified by the heavy wire with red insulator. The input low is identified by the thin wire with black insulator. The case ground is identified by the thin wire with green insulator.

c. Rear Panel Terminals. The rear panel has six binding posts which are used for making special connections to the Model 616.

1. X1 Terminal (White). This terminal provides an analog signal at unity gain. CAUTION Up to 200 volts may be present at this terminal.

2. 1V Terminal (Red). This terminal provides an analog signal with a scale factor of 1 volt for full range input.

3. LO Terminals (Black). These terminals provide a connection to input low. Either terminal may be used for system connections.

4. GUARD Terminal (Blue). This terminal provides a connection to the amplifier feedback when in the FAST mode.

5. GROUND Terminal (Green). This terminal provides a connection to chassis ground. A shorting link is provided for easy connections between low and chassis. For floating applications, the link must be removed.

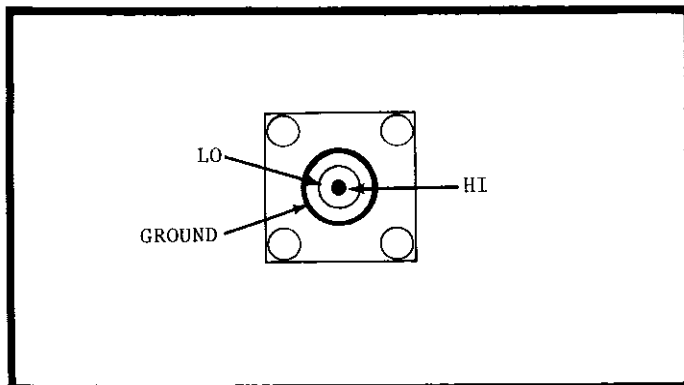

FIGURE 4. Triaxial Input.

3-3. HOW TO SELECT FUNCTION. The Model 616 provides a single front-panel rotary switch for selection of function and range. The RANGE Switch (S101) permits manual selection of any of four functions, namely, VOLT, OHMS, COULOMB, and AMPERE.

3-4. HOW TO USE THE VOLT FUNCTION. The Model 616 provides five decades of voltage sensitivity from .01000 volts to 100 volts full range. The VOLT function is selected by setting the RANGE switch to VOLT.

a. Manual Sensitivity Settings. The front panel SENSITIVITY switch has six positions. As the switch is rotated counter clockwise, the sensitivity is increased. These positions correspond to full range sensitivities of 100.0V, 10.00V, 1.000V, .1000V, and .01000V as in Table 3-1. Position six is the AUTO sensitivity mode which enables either automatic sensitivity or remotely selected sensitivity (when used with the Model 6162). See paragraph 3-4c for a complete explanation of AUTO mode.

TABLE 3-1. Voltage Sensitivity Settings

Sensitivity Setting	Full Range Display	Maximum Display
10 mV	.01000 V	± .01999 V
100 mV	.1000 V	± .1999 V
1 V	1.000 V	± 1.999 V
10 V	10.00 V	± 19.99 V
100 V	100.0 V	± 199.9 V*

*The display indicates 000.0V at 200.0 volts input. The three least significant digits will flash on and off (blinking action) to indicate an over-voltage condition. The display will continue to read up to ±201.7 volts with blinking action. Beyond ±201.7 volts the display will indicate 001.7 volts with blinking action.

CAUTION

Voltage inputs greater than ±200 volts are not recommended since damage to the instrument may result.

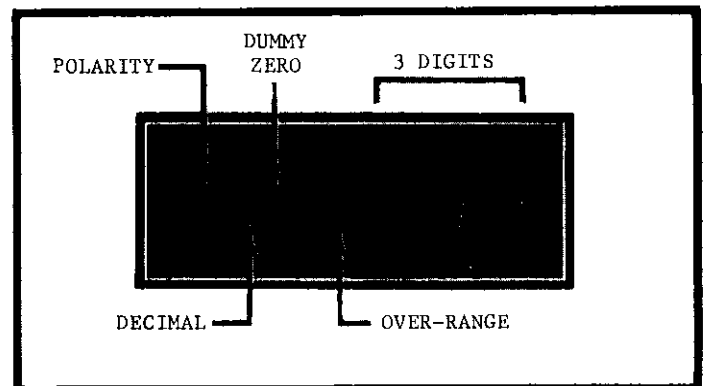

FIGURE 5. Typical Display on 10 mV Sensitivity.

b. Automatic Sensitivity Operation. In the AUTO mode, the Model 616 automatically selects the proper sensitivity in accordance with the following rules.

1. Up-ranging. If the display reading is between 0-1-8-0 and 1-9-9-9 and the input signal is increased beyond 1-9-9-9, the Model 616 automatically up-ranges to the next higher (less sensitive) range. The three least significant digits are blanked during range changing so as to prohibit incorrect readings from being displayed. If the input signal exceeds ± 199.9 volts the display will continue to indicate up to ± 201.7 volts but the three least significant digits will flash on and off to indicate an over voltage condition.

2. Down ranging. If the display reading is at least 0-1-8-0 and the input signal is decreased, the Model 616 automatically down ranges to the next lower (more sensitive) range.

c. Remote Sensitivity Selection. When the Model 616 is used with the Model 6162 Isolated Output/Control, the 616's voltage sensitivity may be remotely selected. The output connector on the rear panel of the 6162 provides four isolated control lines for the purpose of remote sensitivity programming. The lines are coded as shown in Table 3-2. The 616's front panel SENSITIVITY switch must be set to AUTO position.

TABLE 3-2.
Remote Sensitivity Programming Logic

Sensitivity	Control Lines			
	MR*	R ₄	R ₂	R ₁
.01000 V	0	0	0	0
.1000 V	0	1	0	0
1.000 V	0	1	0	1
10.00 V	0	1	1	0
100.0 V	0	1	1	1

***NOTE**

The Manual Range line MR is used to defeat the automatic sensitivity feature. When MR is open, the 616 returns to automatic operation. Logic 1 = open, Logic 0 = closure to ground.

3-5. HOW TO SELECT RANGE ON OHMS, COULOMB, AND AMPERE.

The front panel RANGE switch (SI01) provides selection of four functions, VOLT, OHMS, COULOMB, and AMPERE as described in paragraph 3-3. For each function, a wide selection of ranges is provided; 8 ranges on OHMS, 4 ranges on COULOMB, and 11 ranges on AMPERE. Since the SENSITIVITY switch is used in conjunction with the RANGE Switch, the actual number of useable spans is 12 decades on OHMS, 8 decades on COULOMB, and 11 on AMPERE.

NOTE (ON AMPERE FUNCTION)

On the $10^{-1}A$ to $10^{-4}A$ ranges, the voltage developed must not exceed 2 volts, otherwise, overheating of a range resistor could result. As a result, the 10 volt and 100 volt sensitivity settings are not recommended for $10^{-1}A$ to $10^{-4}A$ ranges.

To interpret a reading on OHMS, COULOMB, or AMPERE ranges both the digital display (with decimal location) and the RANGE setting (powers of ten) should be considered. For example, given a digital reading of 17.32 and a RANGE setting of 10^{-7} AMPERE, the actual measured value would be interpreted as 17.32×10^{-7} ampere. Since the decimal point is moveable, it is important to notice the position of the demimal point to determine the full range of the instrument. See Table 3-3 for typical range settings in the AMPERE function.

TABLE 3-3.
Typical Current Range Settings*

Input Current	Range Setting	Sensitivity Setting	Digital Display
$10^{-15}A$	$10^{-11}A$	10 mV	.00010
$10^{-14}A$	$10^{-11}A$	10 mV	.00100
$10^{-13}A$	$10^{-11}A$	10 mV	.01000
$10^{-12}A$	$10^{-11}A$	100 mV	.1000
$10^{-11}A$	$10^{-11}A$	1 V	1.000

*The current reading is interpreted by multiplying the display reading times the range setting. Other currents not shown can be measured by selecting the appropriate RANGE switch setting in decade steps from $10^{-11}A$ to $10^{-1}A$.

3-6. HOW TO MEASURE VOLTAGE.

The Model 616 can be used to measure voltages from ± 10 microvolts to ± 200 volts. Although the Model 616 is useable as a general purpose digital voltmeter, it has certain characteristics which enable reliable measurements from very-high source resistances. When used in the VOLT mode, the Model 616 has an input resistance greater than $2 \times 10^{14}\Omega$. As a result, the loading of the source circuitry is relatively insignificant when compared to typical digital voltmeters having 10^8 ohms input resistance. The Model 616 has 20 picofarads of shunt capacitance (not including the input cable capacitance). Since a large amount of capacitance causes a slowing of response, the input capacity should be kept as small as possible.

a. Measurements From Very High Source Resistance.

To use the Model 616 as a voltmeter, set the front panel controls as follows:

- RANGE -- VOLT
- SENSITIVITY -- AUTO
- FAST/NORMAL -- NORMAL

Connect a Model 6011 Triax Cable (or other shielded triaxial cable) to the INPUT receptacle. Keep cable length as short as possible to reduce the slowing effects of cable capacitance. The zero control may need occasional adjustment to reduce any voltage offset which may occur due to temperature variations. To rezero the Model 616, set the ZERO CHECK switch to CHECK position and adjust the front panel ZERO control for a 0-0-0-0 display. The Model 616 provides a direct reading voltage display with automatic decimal point position and polarity.

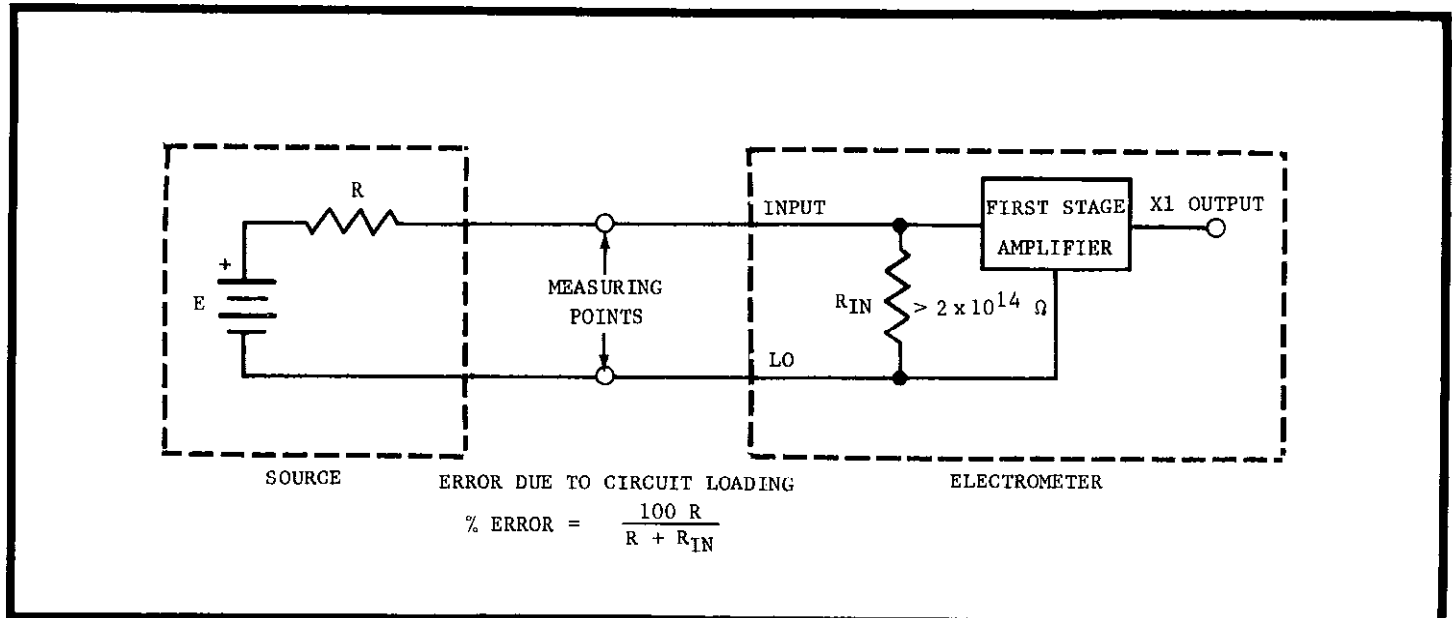

Figure 6. Operation As a Voltmeter in NORMAL Mode.

b. Measurements From Low Source Resistance. To use the Model 616 for voltage measurements from low source resistances, set the RANGE switch to the 10^{-11} AMPERE position. In this mode, the Model 616 input resistance is reduced to 10^{11} ohms; as a result the electrometer will be less sensitive to electrical noise pickup and input cable vibration. Voltage measurements can be made by following the same procedure given in paragraph 3-6a. The Model 616 can be used with the RANGE set at any position between 10^{-11} AMPERE to 10^{-1} AMPERE. The Model 616 input resistance can be determined by taking the reciprocal of the AMPERE setting. Significant loading error may result if the input resistance is reduced to less than 100x the source resistance.

c. Measurements Above 200 Volts. The Model 616 can be used with accessory divider probes to measure voltages up to 30 kilovolts. Range must be set to VOLT.

1. Model 6102A Divider Probe (10:1). This accessory extends the voltage measuring capability of the Model 616 to 1000 volts. The input resistance is 10^{10} ohms. The divider accuracy is $\pm 4\%$ to 1000 volts. (To use the Model 6102A an accessory Model 6012 Adapter is needed to mate the triaxial input with the UHF connector on the probe.)

2. Model 6601A Divider (100:1). This accessory extends the voltage measuring capability of the Model 616 to 5000 volts. The input resistance is 10^7 ohms. The divider accuracy is $\pm 0.01\%$.

3. Model 6103A Divider Probe (1000:1). This accessory extends the voltage measuring capability of the Model 616 to 30 kilovolts. The input resistance is 10^{12} ohms. The divider accuracy is $\pm 5\%$ to 30 kilovolts. (To use the Model 6103A an accessory Model 6012 Adapter is needed to mate the triaxial input with the UHF connector on the probe.)

NOTE

The Model 616 may exhibit a large amount of zero offset or drift immediately after an overload or a long period of storage. In addition, the offset current may exceed the specification for a short time until the Model 616 is sufficiently stabilized. Although the offset current of the Model 616 is well below offset found in conventional voltmeters, the effects of the offset current charging the input capacitance may be noticed when the input is open. Use the ZERO CHECK switch to discharge the offset charge.

CAUTION

The Model 616 should not be operated with circuit low floating by greater than 1000 volts with respect to chassis ground. If the Model 616 is to be used with circuit low floating make certain that no connection is made between the LOW and GROUND terminals on the rear panel. Do not connect a grounded recorder or other instrument to the X1 or 1V outputs when the Model 616 is floated.

d. Voltage Measurements in FAST Mode. When the FAST/NORMAL Switch is set to FAST, the Model 616 is connected in a "FEEDBACK" amplifier configuration. In this configuration, the Model 616 requires special connections. To measure voltage, connect the source between input HI and GUARD. An easy way to accomplish this connection is to connect the link (on the rear panel) between "GUARD" (blue terminal) and "GROUND" (green terminal). Then use the triaxial cable for input connections with the input voltage applied between the "red" clip lead and the "green" clip lead.

NOTE

In this special voltage connection, the LO input (black clip lead) is not used since the voltage amplifier configuration has been changed.

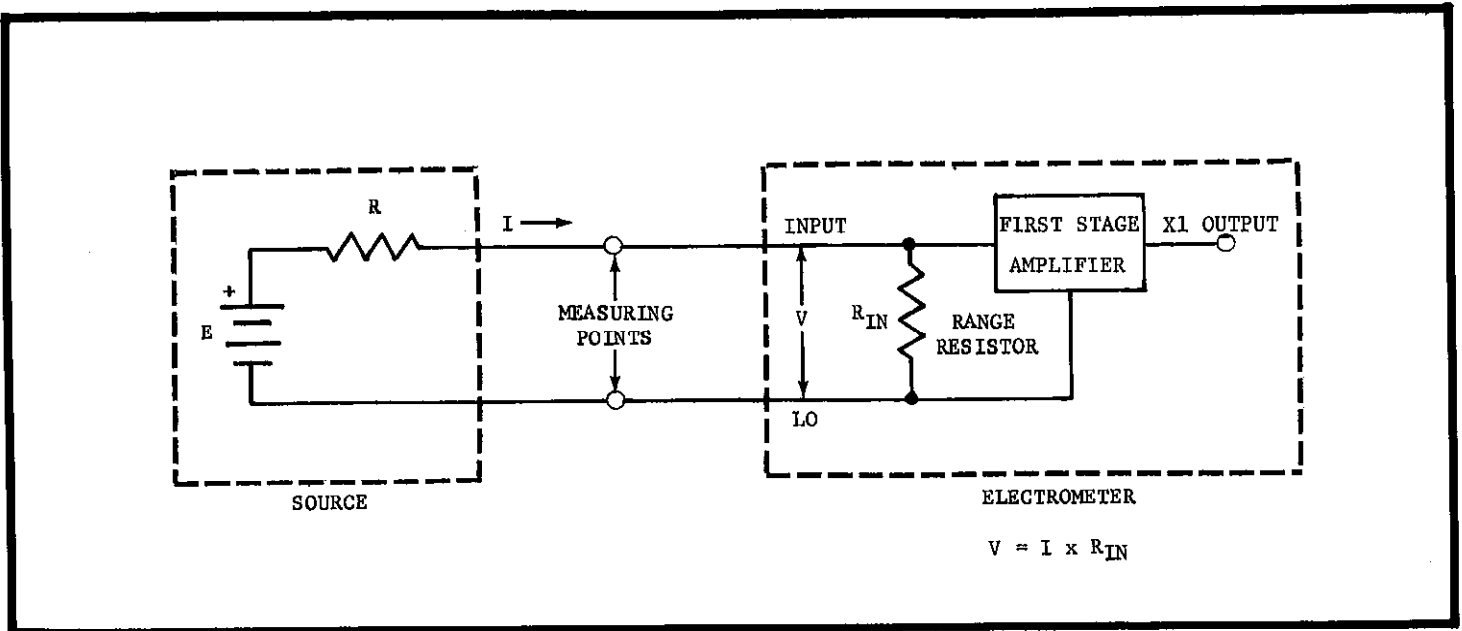

FIGURE 7. Operation As An Ammeter in NORMAL Mode.

3-7. HOW TO MEASURE CURRENT. The Model 616 can be used to measure currents from $\pm 10^{-15}$ ampere to 200 milliamperes. Although the Model 616 is useable as a general purpose picoammeter, it has certain characteristics which enable reliable measurements of very small currents with fast response.

a. Normal Mode Current Measurements. (Use FAST mode for current below 10^{-9} A.) In this mode, the Model 616 measures current over a wide range. When the FAST/NORMAL switch is set to NORMAL, the Model 616 operates as a shunt-type picoammeter in which a resistor is connected directly across the input terminals. The Model 616 measures the voltage drop across the shunt resistors where $V_{IN} = I_{IN} \times R_S$. This method of measurement is typical of most multi-meter current measuring techniques. To use the Model 616 as a shunt-type picoammeter, set the front panel controls as follows:

- RANGE -- 10^{-5} AMPERE (or appropriate range)
- SENSITIVITY -- AUTO
- FAST/NORMAL -- NORMAL

NOTE

Full range is determined by the sensitivity setting and the AMPERE range setting.

Connect a Model 6011 Triax Cable (or other shielded triaxial cable) to the INPUT receptacle. Keep cable length as short as possible to reduce the slowing effects of cable capacitance. The zero control may need occasional adjustment to reduce any voltage offset which may occur due to temperature variations. To rezero the Model 616, set the ZERO CHECK switch to CHECK position and adjust the front panel zero control for a 0-0-0-0 display.

NOTE

The Model 616 may exhibit a large amount of zero offset or drift immediately after an overload or a long period of storage. In addition, the offset current may exceed the specification for a short time until the Model 616 is sufficiently stabilized. Although the offset current of the Model 616 is well below offset found in conventional voltmeters, the effects of the offset current charging the input capacitance may be noticed when the input is open. Use the ZERO CHECK switch to discharge the offset charge.

CAUTION

Do not use the 10 volt and 100 volt sensitivity settings for RANGE switch settings of 10^{-1} , 10^{-2} , 10^{-3} , and 10^{-4} ampere. If the voltage exceeds 2 volts on these ranges, overheating of the resistors could result with subsequent degradation of accuracy in the AMPERE mode.

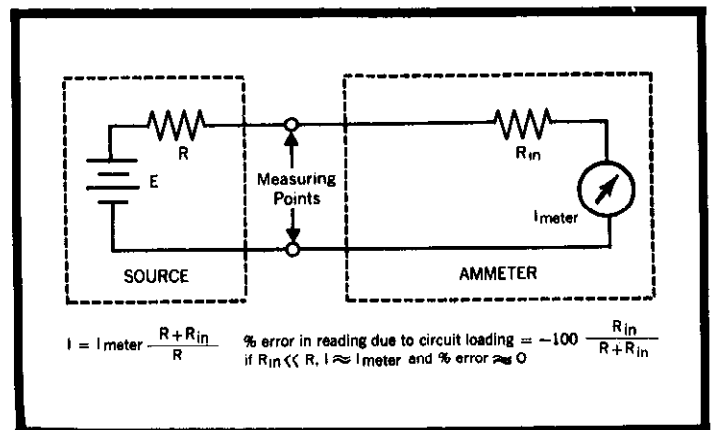

FIGURE 8. Loading Effects in Ammeter Function.

b. Fast Mode Current Measurements. (Useable for currents from 10^{-5} A and smaller.) In this mode, the Model 616 measures very small currents with fast response. When the FAST/NORMAL switch is set to FAST, the Model 616 operates as a feedback-type picoammeter in which the current flows through the feedback resistor of the voltage amplifier. The Model 616 indicates the voltage developed across the range resistor where $V_F = I_{IN} \times R_F$. This method of measurement provides fast response since the effect of the input capacitance from lengthy cables is diminished. To use the Model 616 as a feedback-type picoammeter, set the front panel controls as follows:

- RANGE -- 10^{-11} AMPERE
- SENSITIVITY -- AUTO
- FAST/NORMAL -- FAST

Connect a Model 6011 Triax cable (or other shielded triaxial cable) to the INPUT receptacle. The zero control may need occasional adjustment to reduce any voltage offset which may occur due to temperature variations. To rezero the Model 616, set the ZERO CHECK switch to CHECK position and adjust the front panel ZERO control for a 0-0-0-0 display.

NOTE

The Model 616 may exhibit a large amount of zero offset or drift immediately after an overload or a long period of storage. In addition, the offset current may exceed the specification for a short time until the Model 616 is sufficiently stabilized. Although the offset current of the Model 616 is well below offset found in conventional voltmeters, the effects of the offset current charging the input capacitance may be noticed when the input is open. Use the ZERO CHECK switch to discharge the offset charge.

c) Considerations When Measuring Current. When using the Model 616 in either the NORMAL or FAST modes, there are certain considerations which ensure optimum performance. In general, it is advantageous to use the smallest possible value of shunt resistance for a picoammeter. First, small value resistors are of higher quality compared to large values with respect to accuracy, time stability, temperature, and voltage coefficient. Second, ideal picoammeters require very small input resistance so that source loading does not affect the overall accuracy of the measurement. Since the input resistance in a shunt picoammeter is determined by the range resistor, the RANGE multiplier should be set at the lowest value. Third, the use of a low value resistor reduces the input RC time constant and results in faster response. However, since noise and zero drift become more significant when the voltage amplifier sensitivity is set to 10 or 100 millivolts,

the appropriate range multiplier should be selected with a one volt full scale sensitivity. The use of the Model 616 in the FAST mode enables measurements of very small currents while reducing the source loading and input RC time constant. Since the range resistor is connected in the feedback of the voltage amplifier, the effective input resistance is determined by the open-loop gain where $R_{IN} = R_F \div A$. (The value of A is typically 10,000.) Another advantage of the feedback mode is the reduced effect of input capacitance since the input RC time constant is decreased by the gain A ($RC_{EFFECTIVE} = RC \div A$). As a result, the measurement speed is governed by the feedback time constant which is a function of the feedback resistor and stray capacitance across the resistor (usually a few pF). Thus, when comparing shunt versus feedback modes, it is evident that the feedback measurement offers superior performance for most applications.

TABLE 3-4.
HOW TO SELECT APPROPRIATE AMPERES RANGE.

Current To Be Measured	Appropriate Range Setting	Appropriate Sensitivity Setting	Reading
10^{-15} A	10^{-11}	10 mV	$.00010 \times 10^{-11}$ A
10^{-14} A	10^{-11}	10 mV	$.00100 \times 10^{-11}$ A
10^{-13} A	10^{-11}	10 mV	$.01000 \times 10^{-11}$ A
10^{-12} A	10^{-11}	100 mV	$.1000 \times 10^{-11}$ A
10^{-11} A	10^{-11}	1 V	1.000×10^{-11} A
10^{-10} A	10^{-10}	1 V	1.000×10^{-10} A
10^{-9} A	10^{-9}	1 V	1.000×10^{-9} A
10^{-8} A	10^{-8}	1 V	1.000×10^{-8} A
10^{-7} A	10^{-7}	1 V	1.000×10^{-7} A
10^{-6} A	10^{-6}	1 V	1.000×10^{-6} A
10^{-5} A	10^{-5}	1 V	1.000×10^{-5} A
10^{-4} A	10^{-4}	1 V	1.000×10^{-4} A
10^{-3} A	10^{-3}	1 V	1.000×10^{-3} A
10^{-2} A	10^{-2}	1 V	1.000×10^{-2} A
10^{-1} A	10^{-1}	1 V	1.000×10^{-1} A

NOTE

The use of the FAST mode for current measurements is subject to certain restrictions as follows:

1. The range resistor value should not be greater than the source resistance, otherwise feedback division results in zero instability at the output.
2. The largest value of current measured should not exceed 10^{-5} ampere, otherwise the full feedback current cannot be developed. The NORMAL mode should be used for currents from 200 mA to 10^{-4} A.

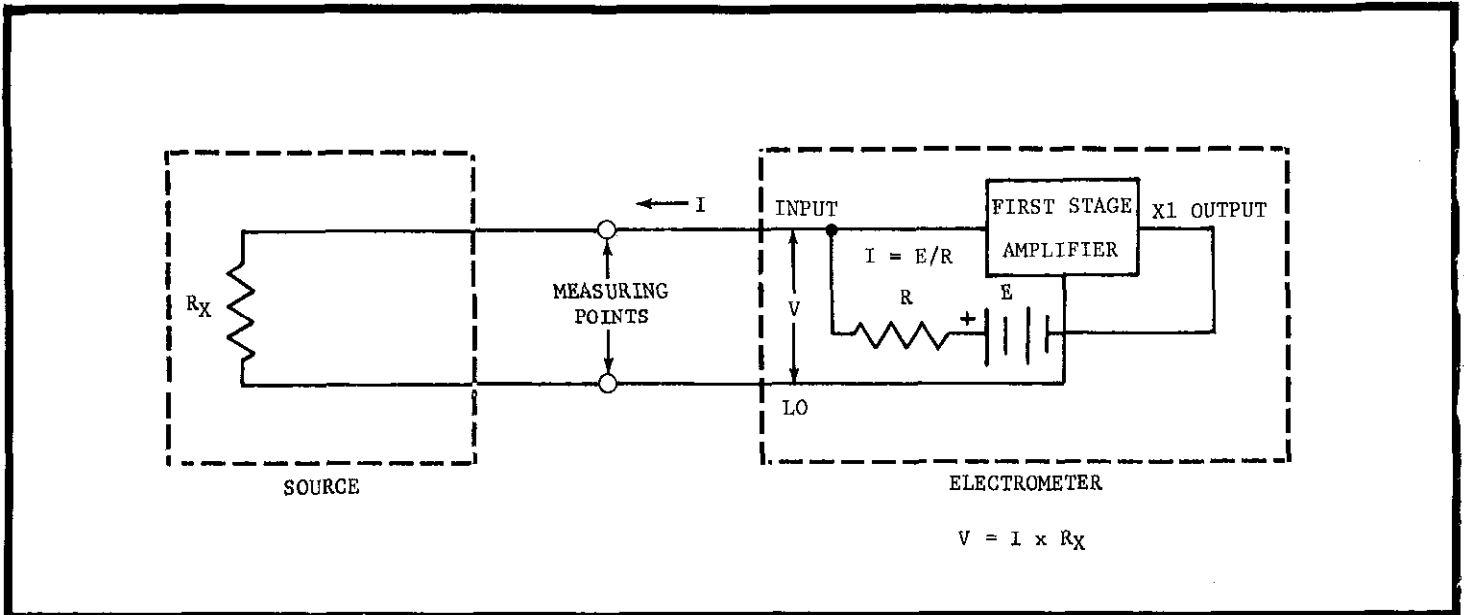

FIGURE 9. Operation As An Ohmmeter in NORMAL Mode

3-8. HOW TO MEASURE RESISTANCE. The Model 616 can be used to measure resistance from 1 ohm to 2×10^{14} ohms. Although the Model 616 is useable as a general purpose ohmmeter, it has certain characteristics which enable reliable measurements of very large resistances with fast response.

CAUTION

Up to 250 volts may be present at terminals.

a. Normal Mode Ohms Measurements. In this mode, the Model 616 measures resistance over a wide range. The use of the NORMAL mode is recommended for measurements up to 10^{11} ohms (use the FAST mode for larger resistances). The Model 616 uses a constant current method for measuring resistance. There, the digital readout is proportional to the voltage developed across the input terminals where $V = I \times R$ (the current I is selected in decade steps using the RANGE Switch). To use the Model 616 as an ohmmeter, set the front panel controls as follows:

- RANGE -- 10^5 OHMS (or other appropriate range)
- SENSITIVITY -- AUTO
- FAST/NORMAL -- NORMAL

TABLE 3-5.

HOW TO SELECT APPROPRIATE OHMS RANGE.

Resistance to be Measured	Appropriate Range Setting	Appropriate Sensitivity Setting	Reading
$10^{14} \Omega$	10^{12}	100 V	$100.0 \times 10^{12} \Omega$
$10^{13} \Omega$	10^{12}	10 V	$10.00 \times 10^{12} \Omega$
$10^{12} \Omega$	10^{12}	1 V	$1.000 \times 10^{12} \Omega$
$10^{11} \Omega$	10^{11}	1 V	$1.000 \times 10^{11} \Omega$
$10^{10} \Omega$	10^{10}	1 V	$1.000 \times 10^{10} \Omega$
$10^9 \Omega$	10^8	1 V	$1.000 \times 10^9 \Omega$
$10^8 \Omega$	10^7	1 V	$1.000 \times 10^8 \Omega$
$10^7 \Omega$	10^6	1 V	$1.000 \times 10^7 \Omega$
$10^6 \Omega$	10^5	1 V	$1.000 \times 10^6 \Omega$
$10^5 \Omega$	10^5	1 V	$1.000 \times 10^5 \Omega$
$10^4 \Omega$	10^5	1 V	$.1000 \times 10^4 \Omega$
$10^3 \Omega$	10^5	100 mV	$.01000 \times 10^3 \Omega$
$10^2 \Omega$	10^5	10 mV	$.00100 \times 10^2 \Omega$

Connect a Model 6011 Triax cable (or other shielded triaxial cable) to the INPUT receptacle. Keep cable length as short as possible to reduce the slowing effects of cable capacitance. The zero control may need occasional adjustment to reduce any voltage offset which may occur due to the temperature variations. To rezero the Model 616, set the ZERO CHECK switch to CHECK position and adjust the front panel ZERO control for a 0-0-0 display.

b. Fast Mode Ohms Measurement. In this mode, the Model 616 measures very large resistances with fast response (use this mode for resistances larger than 10^{11} ohms). When the FAST/NORMAL switch is set to FAST, the unknown resistance (R_x) is floating with respect to the low side of the voltage amplifier. The unknown resistor is connected across the feedback so as to reduce the effects of capacitance and therefore speed up the measuring time. To use the Model 616 for FAST ohmmeter measurements, set the front panel controls as follows:

- RANGE -- 10^{12} OHMS
- SENSITIVITY -- AUTO
- FAST/NORMAL -- FAST

Connect the unknown resistance between input HI and GUARD (on the rear panel).

NOTE

When the FAST mode is used for resistance measurements, the unknown resistance sample is connected in feedback around the electrometer amplifier. Therefore the resistance must be floating and not referenced to LO.

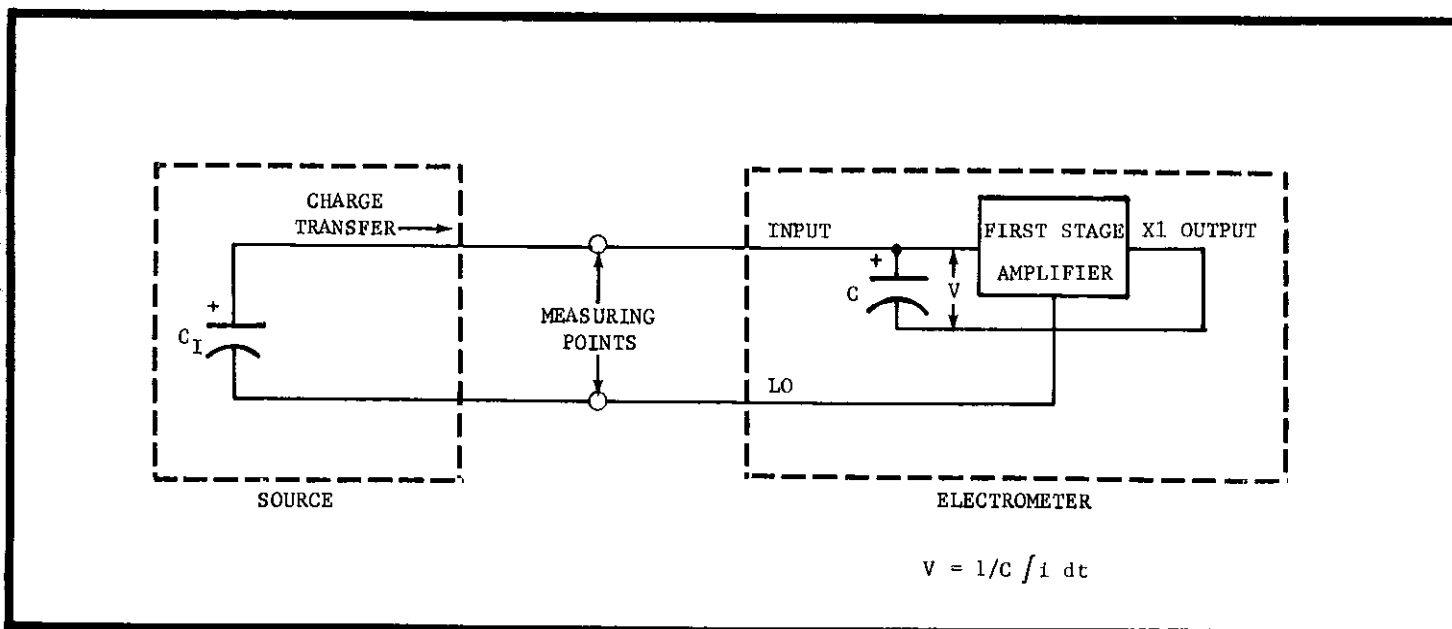

FIGURE 10. Operation As A Coulombmeter in FAST Mode .

3-9. HOW TO MEASURE CHARGE. The Model 616 can be used to measure charge by means of a current integration technique. When the Model 616 is set to anyone of the 4 coulomb ranges, an accurately known capacitor is connected in the feedback loop of the voltage amplifier so that the voltage developed is proportional to the integral of current where $V = \int i dt$ or $V = 1/C \int i dt$. To use the Model 616 as a coulombmeter, set the front panel controls as follows:

- RANGE -- 10^{-10} COULOMB
- SENSITIVITY -- AUTO
- FAST/NORMAL -- FAST

Connect a Model 6011 Triax cable (or other shielded triaxial cable) to the INPUT receptacle. Keep cable length as short as possible to reduce the slowing effects of cable capacitance. The zero control may need occasional adjustment to reduce any voltage offset which may occur due to the temperature variations. To rezero the Model 616, set the ZERO CHECK Switch to CHECK position and adjust the front panel ZERO control for a 0-0-0-0 display.

NOTE

The input offset current of the Model 616 contributes a charge of 5×10^{-15} coulomb per second and should be subtracted from the actual reading.

NOTE

The Model 616 can also be used with accessory Models 2501 or 2503 for measurement of static charge on a dielectric surface. A discussion of static charge measurement is given in section 3-11a.

For more information about Static Charge Measurements, request the Keithley Product Notes entitled "Electrometer Static Charge Measurements".

3-10. HOW TO USE AS A CURRENT SOURCE. The Model 616 can be used as a current source for currents in decade increments from $10^{-5}A$ to $10^{-12}A$. To select current, set Model 616 to OHMS function. Set OHMS range to the appropriate position as shown in Table 3-6. Use NORMAL mode for currents up to $10^{-10}A$, and FAST mode above $10^{-10}A$.

TABLE 3-6.

Current Desired	OHMS Range
$10^{-12}A$	$10^{12} \Omega$
$10^{-11}A$	$10^{11} \Omega$
$10^{-10}A$	$10^{10} \Omega$
$10^{-9}A$	$10^9 \Omega$
$10^{-8}A$	$10^8 \Omega$
$10^{-7}A$	$10^7 \Omega$
$10^{-6}A$	$10^6 \Omega$
$10^{-5}A$	$10^5 \Omega$

NOTE

When input to Model 616 is not connected, set Zero Check Switch to CHECK. If no input connection is made a large voltage (up to 200V) can appear across the input.

3-11. ALTERNATE MEASUREMENTS. The Model 616 can also be used with Keithley accessories which extend the measuring capabilities of the electrometer.

a. Static Charge Measurements. The Model 616 can be used with Models 2501 or 2503 Static Detector Probes for measurement of static charge on a dielectric surface. When using this method, the Model 616 is operated as a voltmeter with a reading directly in volts. (Do not attempt to measure static charge with the Model 616 in the COULOMB mode.)

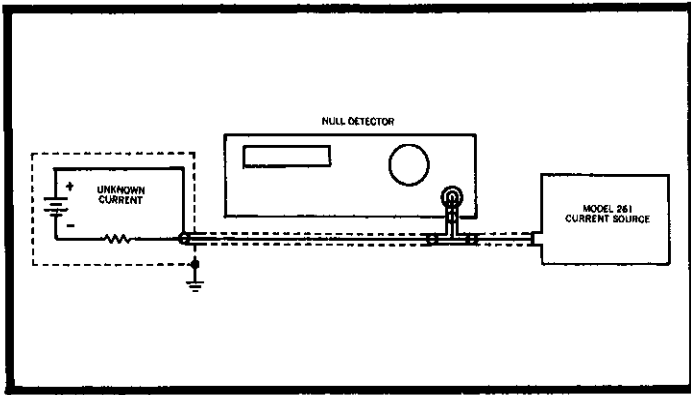

FIGURE 11. Null Method for Current Measurement.

b. Null Method for Current Measurements. The Model 616 can be used with an accurate current source such as Keithley Model 261 to measure small variations of current. When using this method, the Model 616 is operated as a current null detector in the FAST mode. The current source should be adjusted to obtain a null reading on the Model 616 (the electrometer should be set to an appropriate range and sensitivity depending on the magnitude of current variation).

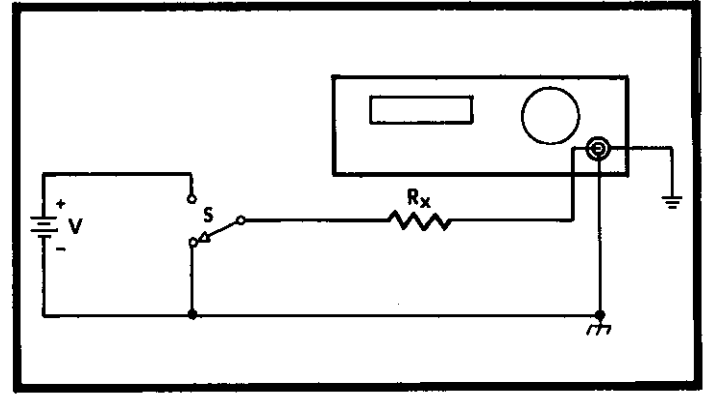

FIGURE 12. Volt-Ammeter Resistance Method.

c. Volt-Ammeter Resistance Measurements. The Model 616 can be used with an accurate voltage source such as Keithley Models 240A, 244, 245, or 246. When using this method, the Model 616 is operated as a picoammeter so that the current through the unknown resistance is measured by the electrometer. The resistance is then calculated in terms of the known voltage impressed and the resultant current measured on the electrometer.

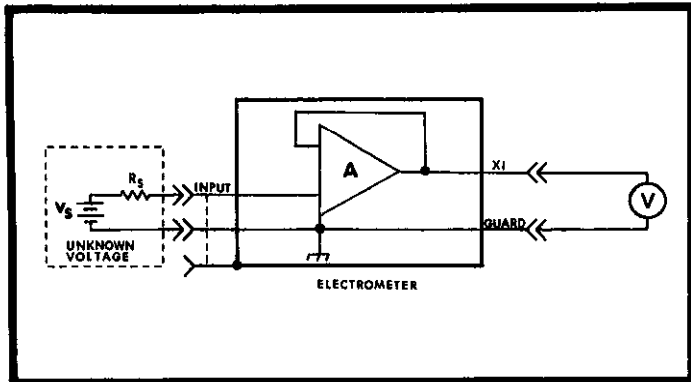

FIGURE 13. Unity-Gain (X1) Measurement.

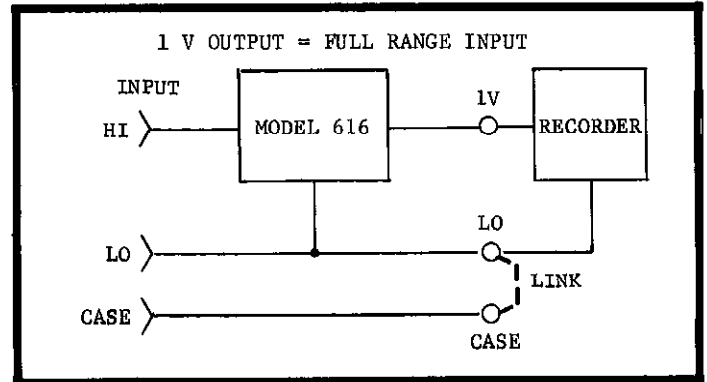

FIGURE 14. Use of 1V Recorder Output.

3-12. HOW TO USE ANALOG OUTPUTS. The Model 616 provides several outputs for monitoring an analog signal.

a. X1 Output (Unity Gain). This output can be used for monitoring the input signal in applications requiring a buffer amplifier.

1. NORMAL MODE. In the NORMAL MODE, the signal at the X1 OUTPUT (with respect to LO) is equal to the input within 20 ppm at dc. The X1 OUTPUT can deliver up to 1 milliampere for outputs up to 200 volts.

2. FAST MODE. In the FAST MODE, the X1 OUTPUT terminal is connected to input LO. For unity gain applications when in FAST mode the GUARD terminal should be used. Typical rise times for various current ranges is shown in Table 3-7. This data is representative of instrument response for unity gain operation.

TABLE 3-7.

Response at GUARD (Unity Gain) OUTPUT for Fast Current*.

Range Setting	Rise Time 10-90%		
	1 V	10 V	100 V
1 x 10 ⁻⁵ A	50 μS	100 μS	500 μS
1 x 10 ⁻⁶ A	300 μS	500 μS	1 mS
1 x 10 ⁻⁷ A	2 mS	3 mS	5 mS
1 x 10 ⁻⁸ A	10 mS	12 mS	15 mS
1 x 10 ⁻⁹ A	60 mS	60 mS	60 mS
1 x 10 ⁻¹⁰ A	300 mS	300 mS	300 mS
1 x 10 ⁻¹¹ A	3 S	3 S	3 S

*Typical instrument performance (may vary from unit to unit).

b. 1 VOLT OUTPUT. This output provides a 1 volt analog output at up to 1 milliampere corresponding to a full scale input.

3-13. HOW TO USE MODEL 6162.

a. General. The Model 6162 Isolated Output/Control provides isolated BCD outputs, remote controls, and remote programming lines for systems use of the Model 616. The Model 6162 has 32 bits of measurement information provided in parallel format. Strobe lines permit data transfer in 4 bit multiples which are compatible with 8, 12, or 16-bit data systems. Strobing of the "open collector" outputs also permit multiplexing of data from 2 or more 6162's on a single data bus. Print rate can be adjusted from 1/5 second to 7 seconds per reading to permit a transfer rate compatible with the speed of measurement and/or the acquisition system. Isolated Remote Controls are provided for Zero Check, Sensitivity, Display Hold, Output Hold, as well as Strobe. The 616's low to chassis ground isolation is maintained by the 6162 (greater than 10^{10} ohms). Digital output low is also isolated from chassis ground by 10^8 ohms.

b. Installation. The 6162 circuitry is housed in a separate 3-1/2 in. high half-rack chassis. It can be used on the bench adjacent to the 616 or rack mounted side-by-side in a standard 19 inch rack width using rack hardware provided (Model 1007).

1. Bench Mounting. Position the Model 6162 on the left side of the Model 616 as shown in Figure 19 since the interconnecting cable has been designed to mate with the 616 in this configuration only. Remove the "side dress" panels (Item 11) on the sides which are adjacent. Loosen the socket head screws (Item 24) and slide the panels to the rear of the instruments. After both panels are removed install the "mounting clamp" (Item 23)

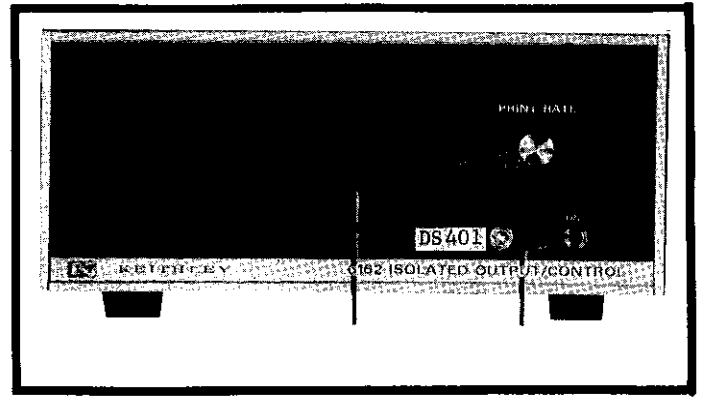

FIGURE 15. Front Panel of Model 6162.

using the original hardware. Remove two screws on one of the instruments and insert the mounting clamp behind the corner bracket as shown in Figure 17. Replace and tighten the two screws to hold the clamp in place. Next, insert the open part of the clamp behind the corner bracket on the second instrument. Attach a 1-1/8" long Phillips head screw (Item 25) and kepnut (Item 26) to secure the two instruments together.

2. Rack Mounting. Proceed as described in the above paragraph for bench mounting. Then attach an "angle bracket" (Item 21) on each instrument using hardware (Item 22) in place of original hardware. The bottom corner feet and tilt bail assemblies may be removed if necessary. The original hardware, side dress panels, feet and tilt bail assemblies should be retained for future conversion back to bench mounting.

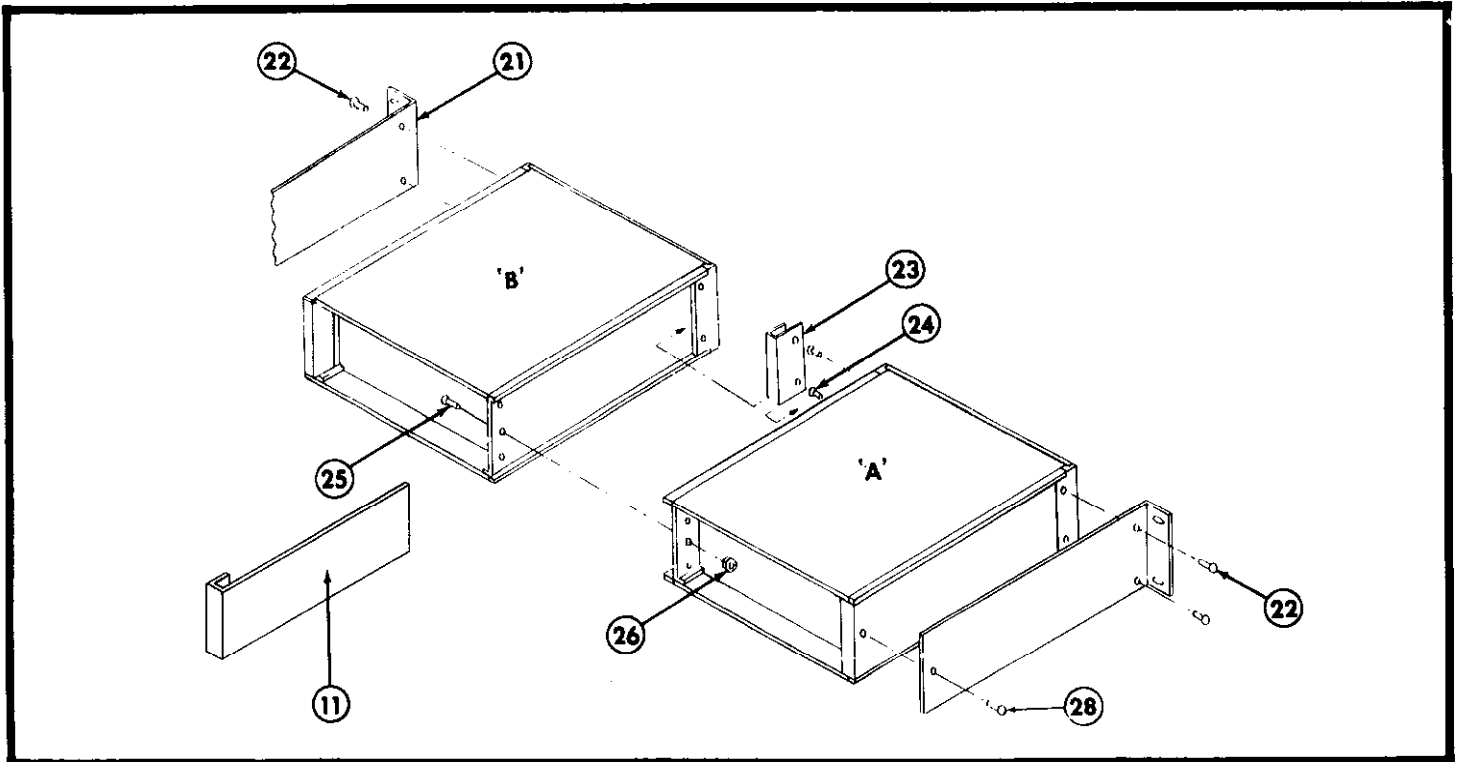

FIGURE 16. Dual Rack Mounting Using Model 1007 Hardware.

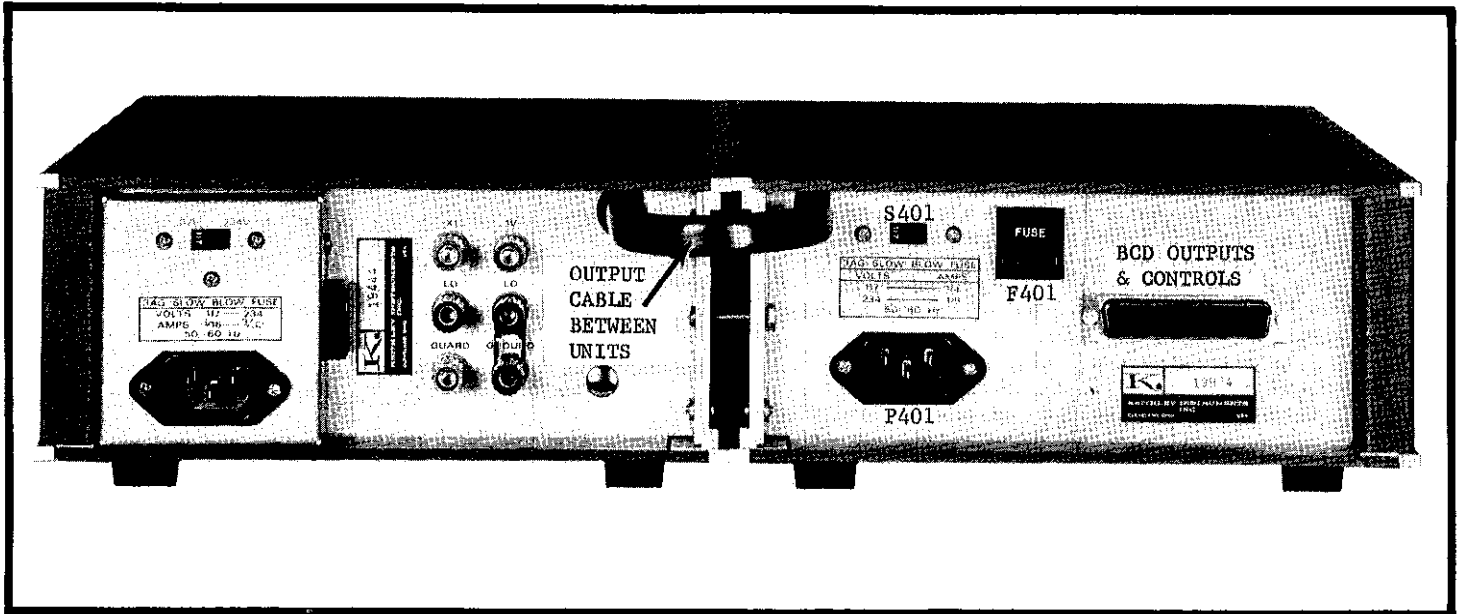

FIGURE 17. Rear Panel of Model 616 and 6162.

c. Connections. A single prewired cable plugs into the 616's chassis to provide all necessary communication between units. To install the cable, remove the 616's top cover, place rubber grommet within the rear panel slot, insert cable, and plug the three mini-connectors into their respective pc-board locations as shown in Figure 19. A separate 50-pin AMP type 205211-1 connector provides isolated outputs and control lines. A mating 50-pin connector is furnished with the 6162 (Keithley Part No. CS-271).

d. Power Requirements. The 6162 is powered from 50-60Hz line voltage and has a separate power switch and fuse. Line voltage is selected using the rear panel switch. Fuse type is 3AG SLO-BLO, 1/8A.

e. Summary of Digital Information. Table 3-10 identifies the data lines available at the 6162 output connector. The data is grouped in 4-bit bytes with a corresponding Strobe line. The strobe (or enable) line permits serial data transfer from a single 6162 or multiplexing of the data output of a number of 6162's onto a common data bus. Conventional parallel data transfer is obtained when all strobe lines are at Logic "0" (closure to output LO within 0.5 volt).

f. Print Rate. The basic 616 has a reading rate of 5 readings per second. The front panel RATE control on the 6162 varies the print rate in 1/5 second increments.

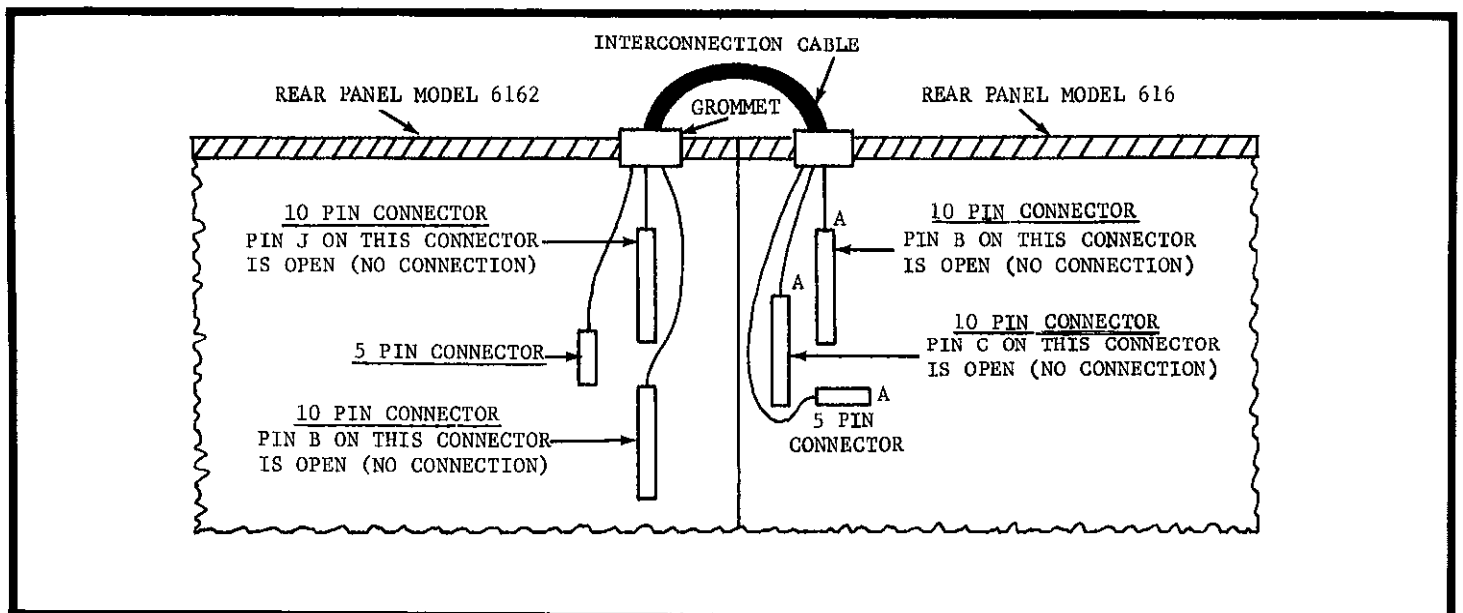

FIGURE 18. Diagram of Interconnection Cable Between 616 and 6162.

TABLE 3-8.
SPECIFICATIONS; MODEL 6162

DIGITAL OUTPUT: BCD (8421) open collector logic represents each of 3 digits (0 = "0000"), overrange digit, uprange ("0"), polarity (+ = "1"), decimal position (5 lines), exponent (5 line, BCD), exponent polarity (+ = "1"), downrange ("0"), zero check ("1"), and function (2 bit code).

ACCURACY: ± 1 digit with respect to 616 display (equivalent to 0.1% of range).

FLAG (FLAG): Logic "1" ("0") from 50 milliseconds to 7 seconds depending on Print Rate setting. No change in Digital Output is made during this interval.

OUTPUT LOGIC LEVELS: Output Logic "1" \equiv open collector to output Lo. Output Logic "0" \equiv closure to output Lo. Output Device: MC858P or equivalent (greater than 6V breakdown, 0.5V at +35mA sink).

REMOTE CONTROLS:

Zero Check: Logic "0" actuates 616 Zero Check.

Sensitivity: 4-line code for remote sensitivity setting of 616.

Display Hold: Logic "0" retains last reading on display (except polarity).

Output Hold: Logic "0" retains data from last reading at Digital Output.

Strobe: 8 lines for serializing in multiples of 4 bits. Logic "1" inhibits controlled output lines.

CONTROL LOGIC LEVELS: Logic "1" \equiv either an open circuit or a voltage between +2 and +12 volts reference to output Lo. Logic "0" \equiv closure to output Lo within 0.5 volt while sinking 2.5 milliamperes.

PRINT RATE: Variable via front panel control from 1/5 second per reading to 7 seconds per reading in 1/5 second increments.

ISOLATION: Input Lo to output Lo: sufficient to maintain 616 isolation specifications except adds 200 picofarads capacitance. Output Lo to chassis ground: greater than 10^8 ohms shunted by 0.1 microfarad. Input may be floated up to ± 1000 volts with respect to chassis ground. Output Lo may be floated up to ± 100 volts with respect to chassis ground.

CONNECTORS: Input: Attached cable connects to 616. Output: 50-pin AMP type 205211-1. Mating connector supplied.

ENVIRONMENT: Operating: 10°C to 50°C, 0% to 70% relative humidity. Storage: 0°C to 70°C.

POWER: 90-125 or 180-250 volts (switch selected), 50-60 Hz, 9 watts.

DIMENSIONS, WEIGHT: Style M 3-1/2 in. half-rack, overall bench size 4 in. high x 8-3/4 in. wide x 15-3/4 in. deep (100 x 220 x 400 mm). Net weight, 7 pounds (3,2 kg).

ACCESSORIES SUPPLIED: Model 1007 Dual Rack Mounting Kit.

g. Data Transfer. Conventional parallel data transfer is accomplished through parallel connections with one bit of information per conductor. Strobing allows data to be grouped into word lengths (bytes) appropriate to the acquisition device, thus simplifying the interfacing between the 6162 and 8, 12, or 16-bit devices. When all STROBE lines are at Logic "0", the 6162 data outputs are enabled and are available in parallel form. Individual strobe lines may be used to connect to a common data bus in multiples of 4-bit words. The 6162 "open-collector" outputs are "open" unless the respective strobe lines are at Logic "0". The use of "open-collector" configuration allows the parallel connection of 2 or more 6162 units since none of the outputs will conduct unless strobed. The 6162 outputs are TTL and DTL compatible. The "open collector" output switches between a high and low impedance level rather than specific voltage levels. This permits the user to determine the voltage level defined by logic state "1". The output "1" state may be selected from any voltage over the range of +2 and +12 volts. The "0" state is 0.5V at +35 mA (maximum) sink current.

h. Word Sequence. The particular sequence in which the words appear in serial data transfer is determined by the way the "STROBE" lines are grouped and the order of activation, in addition to the wiring of the data blocks.

1. Control Features.

1. Flag (Flag). This output provides a logic level which can be used to indicate the proper time interval for transfer of data. A logic "1" occurs from 50 milliseconds to 7 seconds depending

on the Print Rate control setting. No change in the Digital Output is made during this interval. On some digital devices, it may be necessary to trigger off the leading edge of the Flag or Flag waveform by differentiating or other wave shaping.

2. Display Hold. This control line retains the last reading on the display (except polarity) when closure is made to digital LO (Pin 4). Neither the a/d conversion nor digital output are affected by this control.

3. Output Hold. This control line retains the last reading at the Digital Output when closure is made to digital LO (Pin 4). Neither the a/d conversion nor digital display are affected by this control.

4. Zero Check. This control line actuates the 616's zero check solenoid to permit monitoring of the electrometer amplifier offset. When the line is released (Logic "1") the 616 returns to normal operating configuration. The front panel ZERO CHECK switch must be set to OFF position to permit remote zero check control.

j. Remote Programming. Remote lines are provided at the 50-pin connector to permit remote selection of sensitivity over five decades. When the 616's SENSITIVITY Switch is set to AUTO position, the sensitivity may be remotely programmed or allowed to function automatically. When the MANUAL RANGE line on the 6162 is at Logical "0" the coded range lines are enabled, and the LSI range lines are disabled.

TABLE 3-9.
Cross-Reference for Digital Outputs.

Name	Pin No.	Remarks	Name	Pin No.	Remarks	
Strobe #1	48	Buffer Control	Strobe #7	3	Buffer Control	
F1	44] Coded function lines See Table 3-12 Logic "1" = +	FLAG	27	Timing Output	
F2	45		FLAG	10	Timing Output	
EXP POL	41					
EXP 1 x 10 ¹	42					
Strobe #2	49	Buffer Control	Strobe #8	20	Buffer Control	
EXP 1 x 10 ⁰	37] Used on OHMS, AMPERE, COULOMB ranges	Zero Check	13	Indication	
EXP 2 x 10 ⁰	38		1 x 10 ³	21	Overrange Output	
EXP 4 x 10 ⁰	35		POLARITY	43	Logic "1" = +	
EXP 8 x 10 ⁰	34		DP1	7	.00000 = 10 mV	
			"0" (10 mV range)	40	Dummy Zero	
Strobe #3	36	Buffer control for Data #1	Strobe #9	39	Buffer Control	
1 x 10 ⁰	17] Data #1 (BCD)	DP2	22	.0000 = 100 mV	
2 x 10 ⁰	12		DP3	5	0.000 = 1 V	
4 x 10 ⁰	11		DP4	6	00.00 = 10 V	
8 x 10 ⁰	16		DP5	23	000.0 = 100 V	
Strobe #4	1	Buffer control for Data #2] <u>The following are not strobed.</u>			
1 x 10 ¹	47] Data #2 (BCD)			Output Hold	2
2 x 10 ¹	29		Display Hold	50	Remote Control	
4 x 10 ¹	28			MANUAL RANGE	31] Sensitivity lines See Table 3-13
8 x 10 ¹	46			R ₁	32	
			R ₂	14		
Strobe #5	18	Buffer control for Data #3	R ₄	33		
1 x 10 ²	30] Data #3 (BCD)	Digital Lo	4	Ground Reference	
2 x 10 ²	25					
4 x 10 ²	26					
8 x 10 ²	24					
Strobe #6	19	Buffer Control	Zero Check	15	Remote Control	
DR	8	Down Range				
UR	9	Up Range				

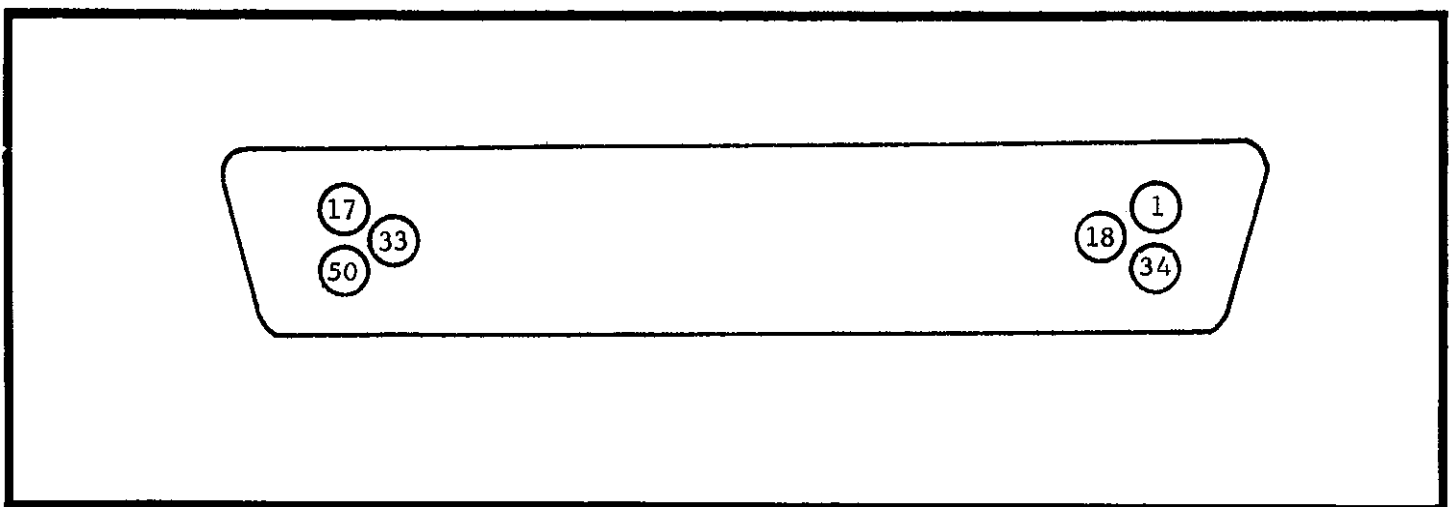

FIGURE 19. Identification of Pins on Digital Output Connector.

TABLE 3-10.
Pin-Out for 50-Pin Connector

Pin No.	Name	Function	Pin No.	Name	Function
1	Strobe #4	Buffer Control	26	4×10^2	Data #3
2	Output Hold	Control	27	FLAG	Timing Output
3	Strobe #7	Buffer Control	28	4×10^1	Data #2
4	Output Lo	GND	29	2×10^1	Data #2
5	DP3 (1.000)*	Decimal Point	30	1×10^2	Data #3
6	DP4 (10.00)*	Decimal Point	31	MANUAL RANGE	Range Control
7	DP1 (.01000)*	Decimal Point	32	R ₁	Range Control
8	DR	Down-range	33	R ₄	Range Control
9	UR	Up-range	34	EXP 8×10^0	Output
10	FLAG	Timing Output	35	EXP 4×10^0	Output
11	4×10^0	Data #1	36	Strobe #3	Buffer Control
12	2×10^0	Data #1	37	EXP 1×10^0	Output
13	ZERO CHECK	Output	38	EXP 2×10^0	Output
14	R ₂	Range Control	39	Strobe #9	Buffer Control
15	ZERO CHECK	Remote Control	40	"0" (10 mV range)	Output
16	8×10^0	Data #1	41	EXP POL	Output
17	1×10^0	Data #1	42	EXP 1×10^1	Output
18	Strobe #5	Buffer Control	43	POLARITY	Output
19	Strobe #6	Buffer Control	44	F ₁	Function
20	Strobe #8	Buffer Control	45	F ₂	Function
21	1×10^3	Data #4	46	8×10^1	Data #2
22	DP 2 (.1000)*	Decimal Point	47	1×10^1	Data #2
23	DP5 (100.0)*	Decimal Point	48	Strobe #1	Buffer Control
24	8×10^2	Data #3	49	Strobe #2	Buffer Control
25	2×10^2	Data #3	50	Display Hold	Control

*HIGH TRUE

TABLE 3-11.
Truth Table for 8-4-2-1 BCD Code

Decimal Number	8×10^n (4th bit)	4×10^n (3rd bit)	2×10^n (2nd bit)	1×10^n (1st bit)
0	0	0	0	0
1	0	0	0	1
2	0	0	1	0
3	0	0	1	1
4	0	1	0	0
5	0	1	0	1
6	0	1	1	0
7	0	1	1	1
8	1	0	0	0
9	1	0	0	1

n = 0,1,2,3, or 4 depending on digit being decoded.

TABLE 3-12.
Truth Table for Function

Function	F ₁	F ₂
OHMS	0	0
COULOMB	1	0
AMPERE	0	1
VOLT	1	1

TABLE 3-13.
Truth Table for Programmed Sensitivity

Sensitivity	Manual Range	R ₄	R ₂	R ₁
.01	0	0	0	0
.01	0	0	0	1
.01	0	0	1	0
.01	0	0	1	1
.1	0	1	0	0
1.	0	1	0	1
10.	0	1	1	0
100.	0	1	1	1

TABLE 3-14.
Truth Table for Serial Transfer

Strobe Line No.	Condition Of Strobe Lines.									Output A	Output B	Output C	Output D
	1	2	3	4	5	6	7	8	9				
1	0	1	1	1	1	1	1	1	1	F_1	F_2	EXP POL	$\text{Exp } 1 \times 10^1$
2	0									$\text{Exp } 1 \times 10^0$	$\text{Exp } 2 \times 10^0$	$\text{Exp } 4 \times 10^0$	$\text{Exp } 8 \times 10^0$
3	0									1×10^0	2×10^0	4×10^0	8×10^0
4	0									1×10^1	2×10^1	4×10^1	8×10^1
5	0									1×10^2	2×10^2	4×10^2	8×10^2
6	0									DR	UR	--	--
7	0									FLAG	$\overline{\text{FLAG}}$	--	--
8	0								1×10^3	POL	DP1	"0"	
9	0									DP2	DP3	DP4	DP5

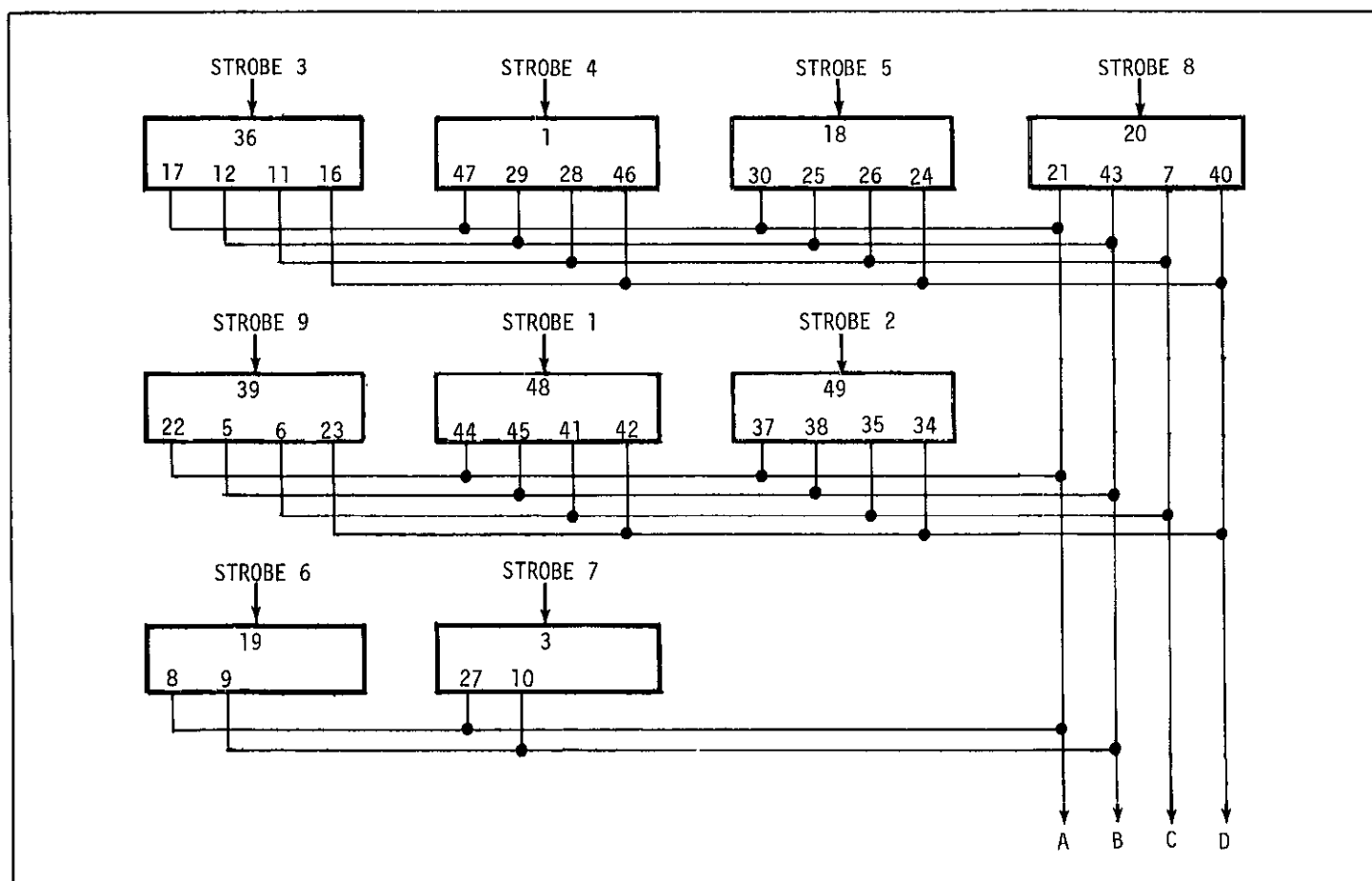

FIGURE 20. Suggested Hook-up for Data Lines.

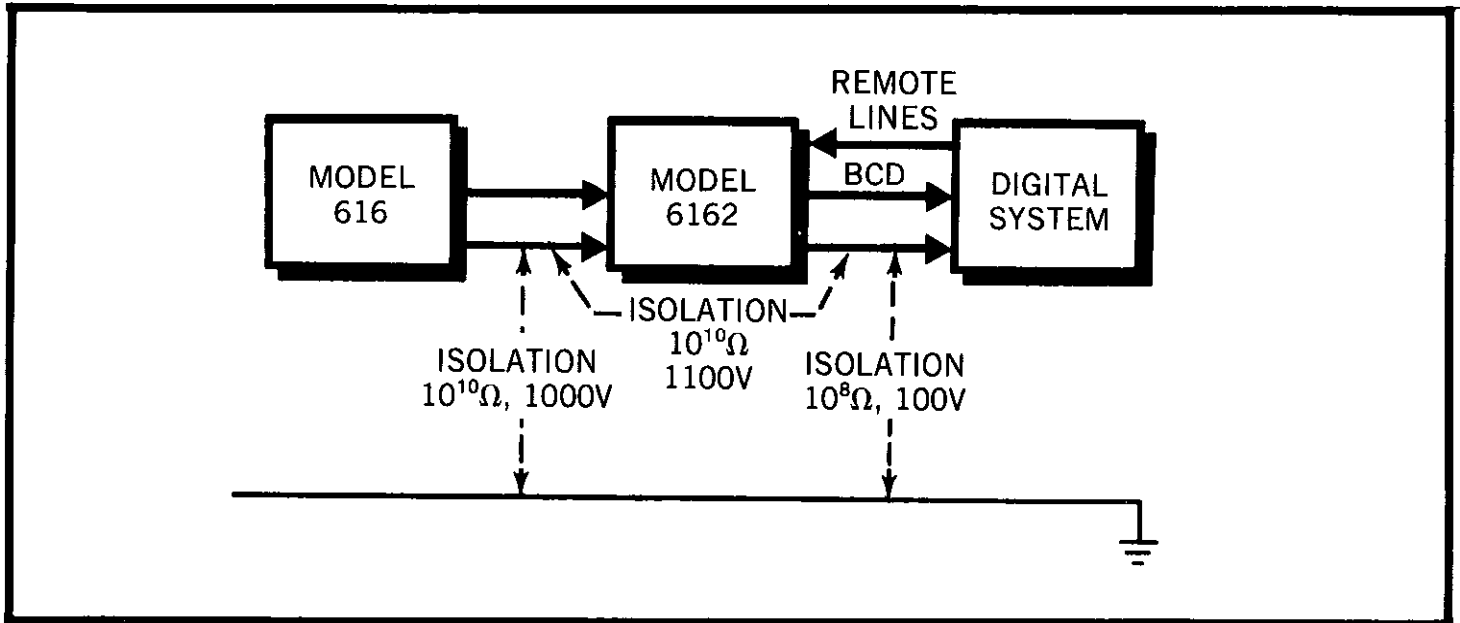

FIGURE 21. Block Diagram of 616/6162 System.

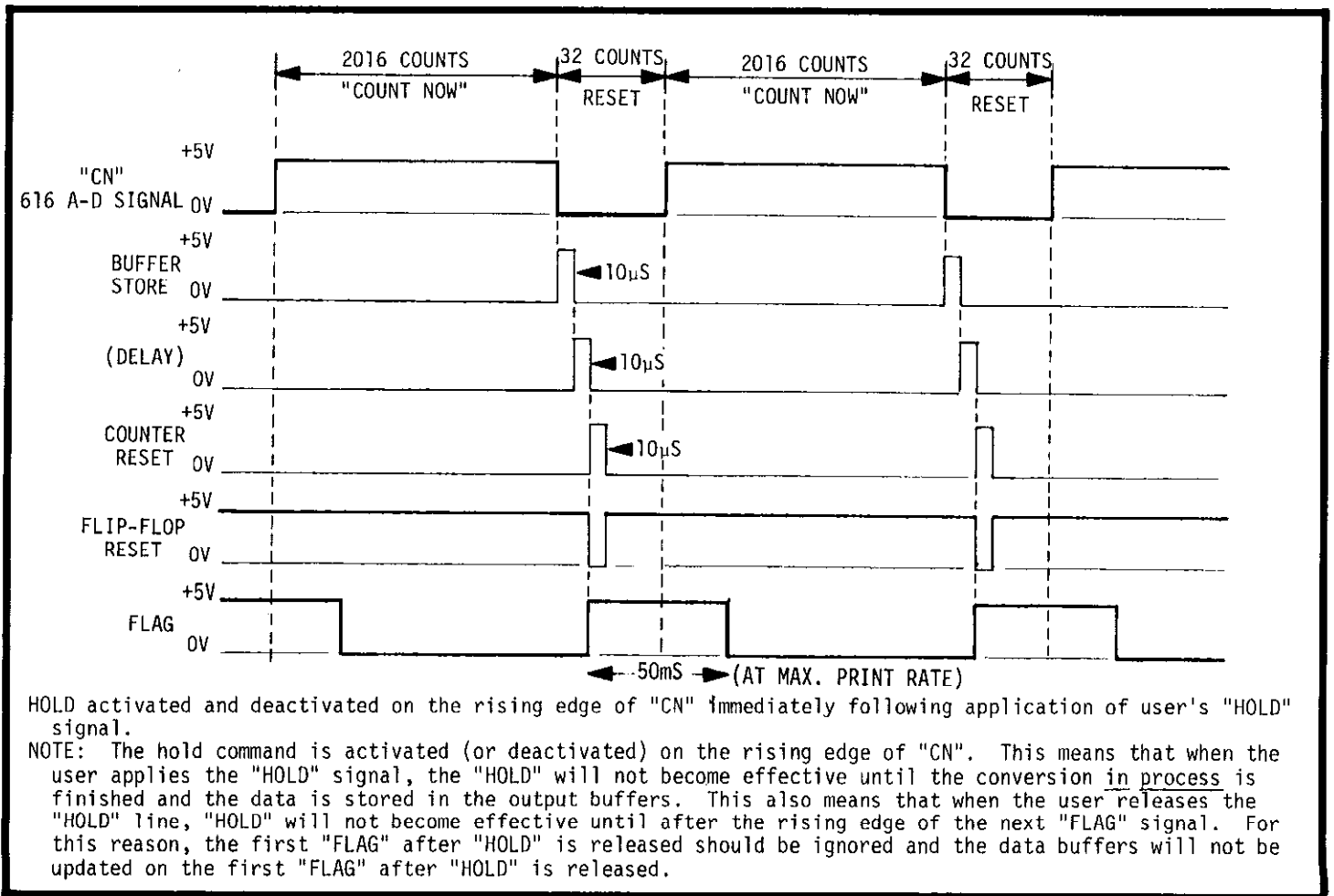

FIGURE 22. Timing Diagram for 6162 Outputs.

HOLD activated and deactivated on the rising edge of "CN" immediately following application of user's "HOLD" signal.

NOTE: The hold command is activated (or deactivated) on the rising edge of "CN". This means that when the user applies the "HOLD" signal, the "HOLD" will not become effective until the conversion in process is finished and the data is stored in the output buffers. This also means that when the user releases the "HOLD" line, "HOLD" will not become effective until after the rising edge of the next "FLAG" signal. For this reason, the first "FLAG" after "HOLD" is released should be ignored and the data buffers will not be updated on the first "FLAG" after "HOLD" is released.

SECTION 4. THEORY OF OPERATION

4-1. GENERAL. This section contains information to describe the Model 616 circuit operation. The circuitry is located on five printed circuit boards. The circuits are arranged in functional modules to facilitate troubleshooting and servicing. The 616's shielded input section houses the electrometer amplifier and range switch.

4-2. ANALOG CIRCUITRY

a. Input Amplifier. This amplifier A_1 is shown in simplified form in Figure 24. (Refer to schematic 25764E). The input signal applied between HI and LO (J120) is amplified by the input MOS-FET amplifier composed of transistors Q101A and Q101B. Transistors Q102A and Q102B are used for over-voltage protection (base-emitter connected). Integrated circuit QA101 provides high gain (approx. 100,000) for the electrometer amplifier section. Potentiometer R123 is an internal zero adjustment used for calibration purposes. Potentiometer R119 is a front panel ZERO control with adjustment capability of approximately 3 mV. Transistors Q105 and Q106 are complementary output stages which provide a maximum of ± 200 volts at the "X1" terminal (J118). The electrometer amplifier is connected in a unity-gain configuration. Input resistance between HI and LO is greater than 2×10^{14} ohms in "VOLTS" function.

b. Shunt (NORMAL) Mode Operation. (Refer to schematic 25764E). In the "NORMAL" mode, the electrometer amplifier is connected as a unity-gain buffer amplifier with an input resistance greater than 2×10^{14} ohms. Input resistance may be decreased in decade steps from 10^{11} ohms to 10 ohms by selecting the desired shunt resistor on the AMPERE positions of the RANGE switch. Resistors R101 through R111 are switched into the circuit shunting the HI and LO terminals. The shunt resistor connected in the circuit is numerically the reciprocal of the AMPERE position selected (that is $10^{-11}A \equiv 10^{11}\Omega$ resistor).

c. Feedback (FAST) Mode Operation. (Refer to schematic 25764E). In the "FAST" mode, the electrometer amplifier is connected in a feedback amplifier configuration. In AMPERE, COULOMB, or OHMS functions, the range element (resistor or capacitor) is connected between HI and GUARD. Input resistance on AMPERE function is determined by the feedback resistor and the open-loop gain, where:

$$R_i = R_f \left(K = 50,000 \text{ minimum} \right)$$

For example, on $10^{-11}A$ range, $R_i = 2 \times 10^6\Omega$. Input voltage drop for full range input current would be less than 20 microvolts.

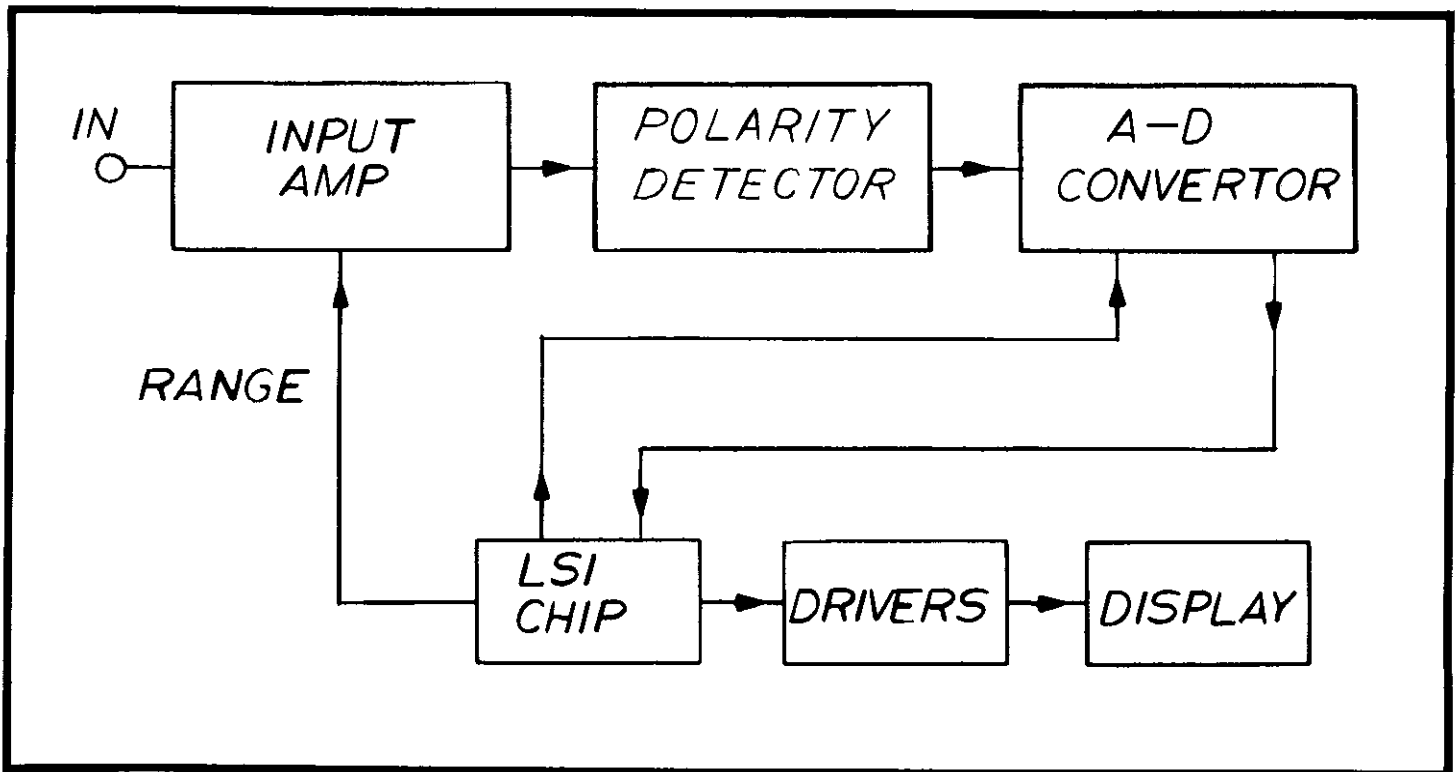

FIGURE 23. Overall Block Diagram of Model 616.

d. Zero Check Operation. (Refer to schematic 25764E). The front panel ZERO CHECK switch (S102) operates a relay solenoid (K101) when set to ZERO CHECK. In the energized state (as shown on the schematic) the relay contact is closed. The closed contact makes a connection between the FET amplifier input and GUARD (J119) as follows:

1. Normal Mode. In this mode, a connection is made between resistor R124 and input LO. Notice that the input HI terminal is shunted to LO by a $10^8\Omega$ resistor (R112).

2. Fast Mode. In this mode, a connection is made between resistor R124 and GUARD. Notice that the input HI terminal remains connected to the electrometer amplifier input. In AMPERE, OHMS, or COULOMB functions, the feedback element is shorted out so that no voltage can be generated across the amplifier feedback.

NOTE

Remote zero check capability is provided when the Model 6162 is connected to the 616. The connection at P113D is in parallel with the front panel switch. The front panel ZERO CHECK switch should be off when using the remote zero check feature.

e. Voltage Sensitivity. This amplifier A_2 is shown in Figure 24. (Refer to schematic 25776D). The second stage variable-gain amplifier is composed of a FET stage (Q301A, Q301B) and an integrated circuit QA301. Gain is determined by resistors RN301 (A to F) where:

$$\text{Gain} = \frac{R_F}{R_I} \text{ (See Table 4-1.)}$$

TABLE 4-1.
Voltage Gain

Sensitivity Setting	R_I	R_F	Gain
.01000 V	500K Ω	50 M Ω	100
.1000 V	500K Ω	5 M Ω	10
1.000 V	500K Ω	500 K Ω	1
10.00 V	500K Ω	50 K Ω	0.1
100.0 V	500K Ω	5 K Ω	0.01

1. Gain Setting. Resistors RN301A to RN301F are connected in parallel combinations to achieve the proper gain. On the 10 mV sensitivity setting, the gain is determined by the series combination of resistors RN301B and R303. Potentiometer R303 is a calibration adjustment for the 10 mV sensitivity setting. For each succeeding sensitivity, the resistors are switched into the circuit as shown in Table 4-2. Potentiometer R304 is a calibration adjustment for the 100V sensitivity setting.

TABLE 4-2.
Gain Switching

Sensitivity	Feedback Resistors Used For Gain Set.
.01000V	50 M Ω (RN301B + R303)
.1000 V	5 M Ω (RN301B + R303//RN301C)
1.000 V	500 K Ω (RN301B + R303//RN301C//RN301D)
10.00 V	50 K Ω (RN301B + R303//RN301C//RN301E)
100.0 V	5 K Ω (All above//RN301F + R304)

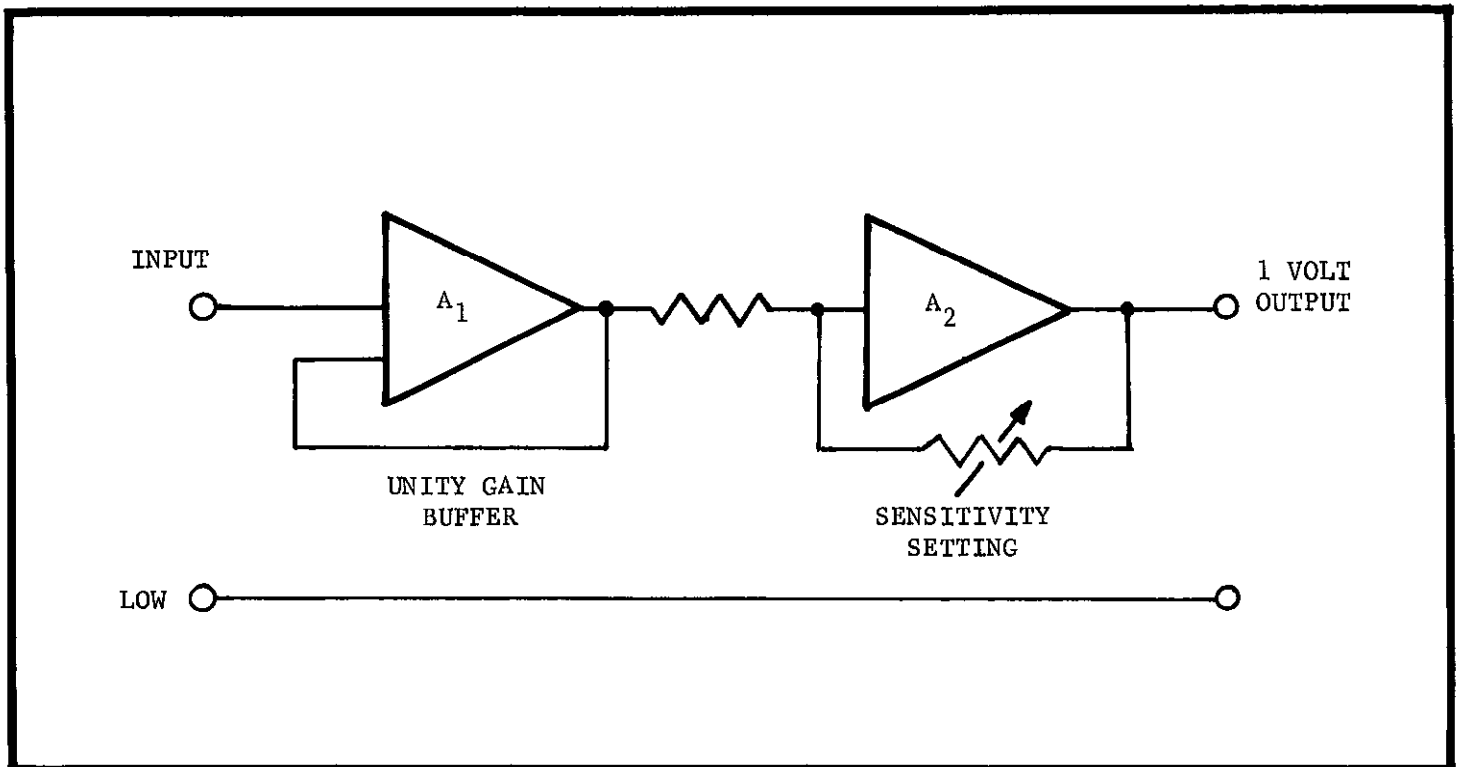

FIGURE 24. Simplified Diagram of Amplifier Section.

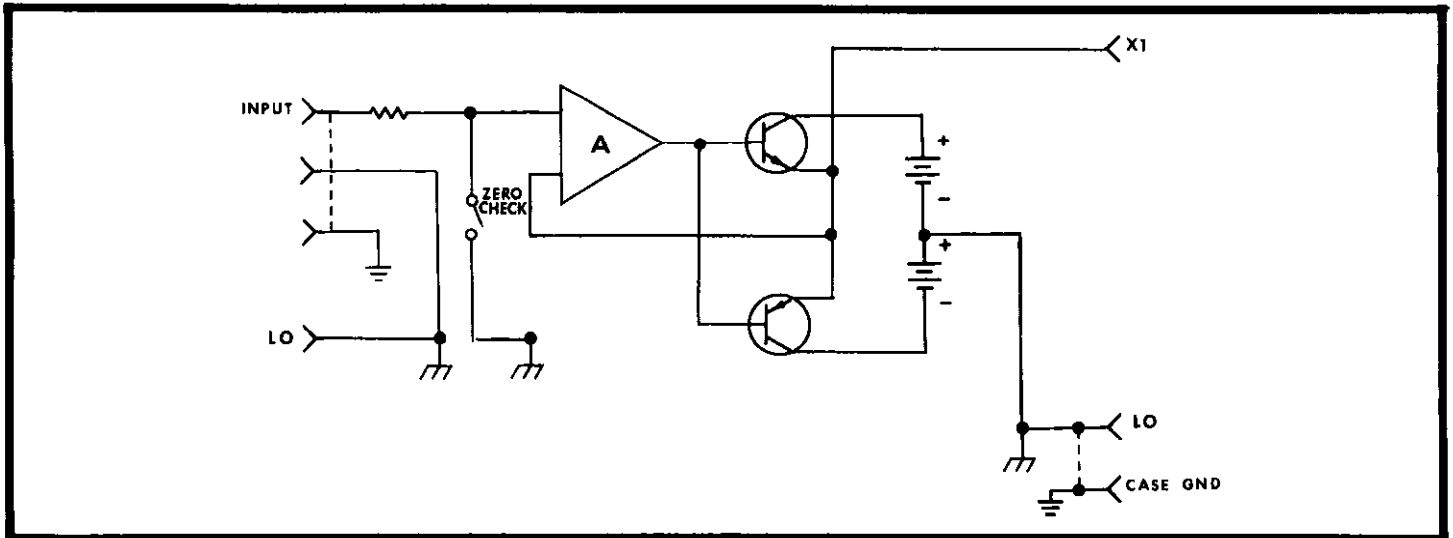

FIGURE 25. Voltmeter Configuration - NORMAL Mode.

2. Gain Selection Logic. (Refer to schematics 25776D, 25778E). A three line ranging code is used to determine voltage sensitivity. The coding for the three lines (R_4 , R_2 , R_1) is given in Table 4-3.

TABLE 4-3.
Ranging Logic

Sensitivity	Ranging Lines		
	R_4	R_2	R_1
.01000 V	0	--	--
.1000 V	1	0	0
1.000 V	1	0	1
10.00 V	1	1	0
100.0 V	1	1	1

where 0 = open state
1 = +5V state

3. Zero Adjustment. Potentiometer R311 is an internal zero adjustment for calibrating the "1V" recorder output.

f. Ammeter Operation. (Refer to schematic 25764E). In the AMPERE mode, a range resistor (R_{101} through R_{111}) is connected between input HI and GUARD. The current-to-voltage conversion is determined by the following relationship:

$$E_R = I \times R$$

E_R = voltage developed across R
 I = input current
 R = range resistor

In the "NORMAL" mode, the input voltage drop is equivalent to E_R . In the "FAST" mode, the input drop is a function of open loop gain (typically $20\mu V$). The use of the FAST mode is limited to ranges $10^{-5}A$ to $10^{-11}A$ due to loading and stability considerations.

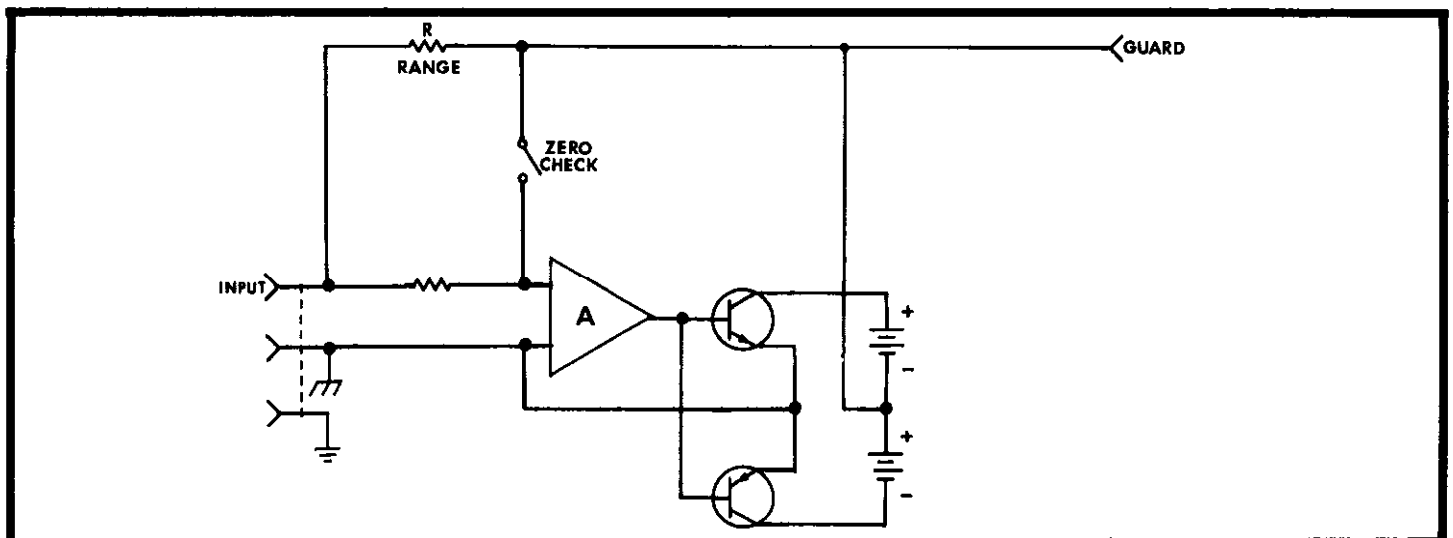

FIGURE 26. Ammeter Configuration - FAST Mode.

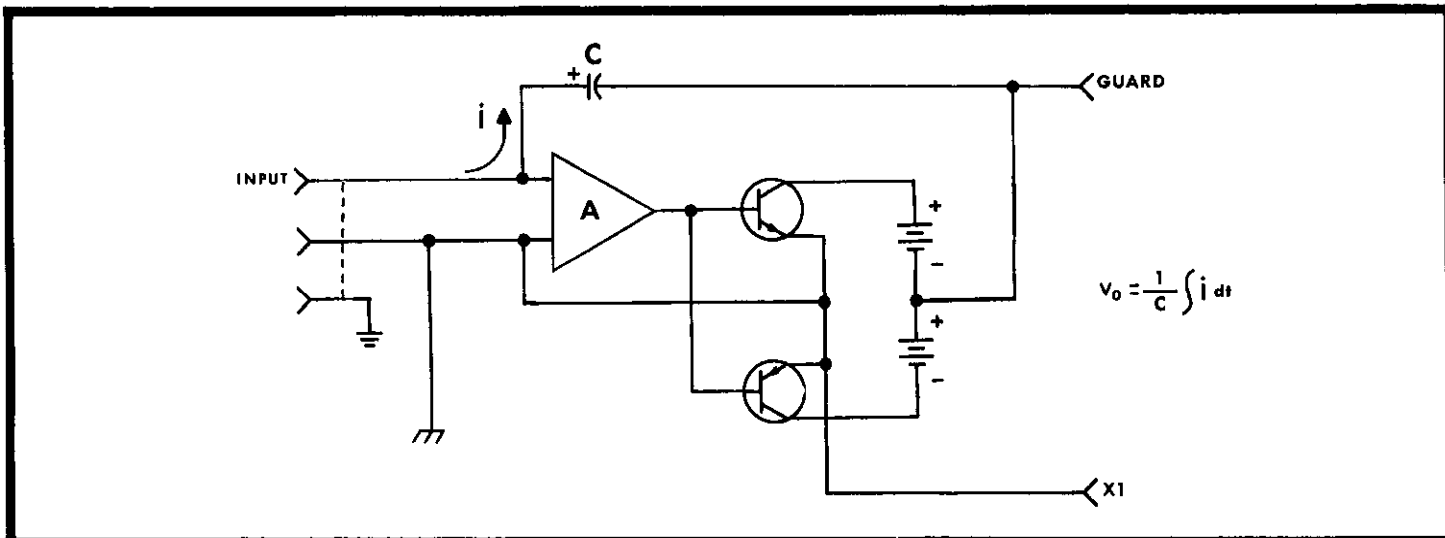

FIGURE 27. Coulombmeter Configuration - FAST Mode.

g. Coulombmeter Operation. (Refer to schematic 25764E). In the COULOMB mode, a range capacitor (C101 through C111) is connected between input HI and GUARD. The charge-to-voltage conversion is determined by the following relationship:

$$E_C = \frac{1}{C} \int i dt = \frac{Q}{C}$$

- E_C = voltage developed across C
- C = range capacitor
- Q = stored charge

h. Ohmmeter Operation. (Refer to schematic 25764E). In the "OHMS" mode, a current source is connected into the electrometer circuitry. The voltage sensitivity is selected as in VOLTS operation. The current source is composed of a voltage source and a series (RANGE) resistor. The series resistor is selected in decade steps in the OHMS position (resistors R105 through R111). The voltage source is provided by dividing down from a ±12 volt reference supply. Potentiometer R114 is an internal calibration adjustment.

TABLE 4-4.
Ohmmeter Divider Network

Ohms Range	R _{Total}	R ₁	R ₂	E
10 ⁵ Ω	12K	1.010KΩ	10.990KΩ	1.01 V
10 ⁶ Ω	12K	1.000KΩ	11.000K	1.00 V
10 ⁷ Ω	12K	1.000KΩ	11.000K	1.00 V
10 ⁸ Ω	12K	1.000KΩ	11.000K	1.00 V
10 ⁹ Ω	12K	1.000KΩ	11.000K	1.00 V
10 ¹⁰ Ω	12K	1.000KΩ	11.000K	1.00 V
10 ¹¹ Ω	12K	1.000KΩ	11.000K	1.00 V
10 ¹² Ω	12K	100	11.9 K	0.1 V

The current developed by the ohmmeter circuit is determined as follows:

$$I = \frac{E}{R} \quad E = 12 R_1 / (R_1 + R_2)$$

where I = current in amperes
 E = voltage as in Table 4-4.
 R = range resistor (R105 through R111).

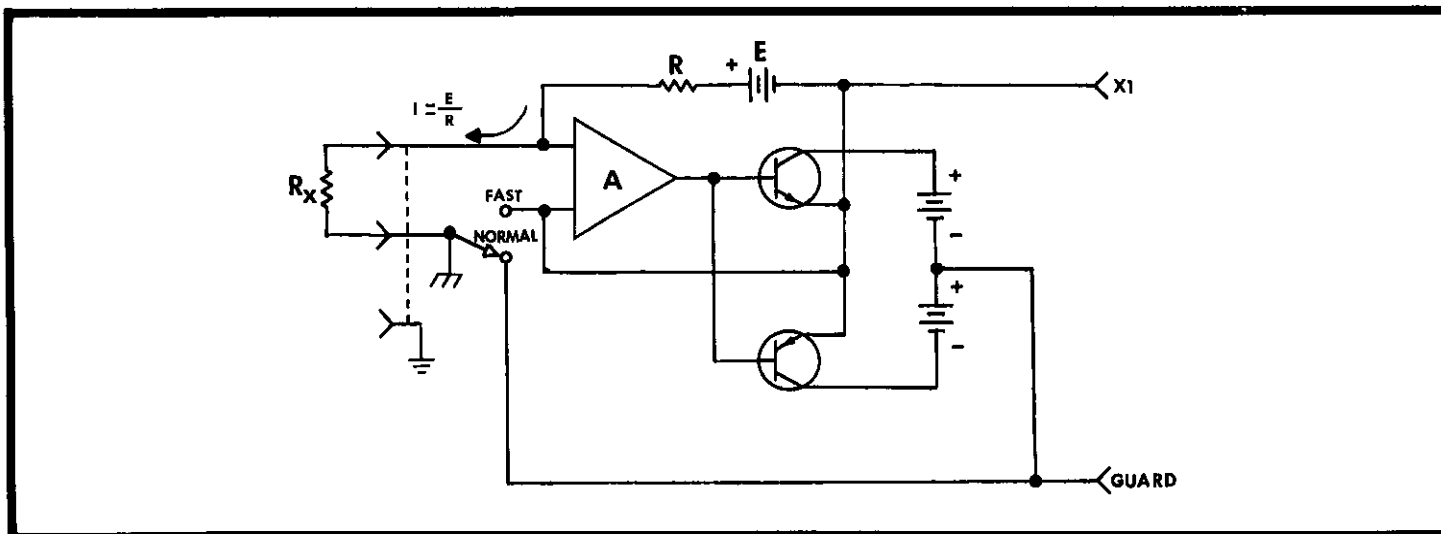

FIGURE 28. Ohmmeter Configuration - NORMAL Mode.

1. Polarity Detection Circuit. (Refer to schematic 25776D). This circuit detects the polarity of the input signal and triggers the polarity display circuitry.

1. First Stage Amplifier. When the input to integrated circuit QA302 is positive-going, diode D301 conducts causing the amplifier to operate with a gain of 2X (inverting). A negative-going input to QA302 is not amplified due to the blocking action of diode D301 which prevents the output of QA302 from going positive. Transistor Q306 conducts to maintain feedback around QA302 and therefore provides polarity information to turn-off the "minus" polarity.

2. Second Stage Amplifier. Integrated circuit QA303 is used as an inverting summing amplifier. For a positive-going input to the polarity detection circuit, QA303 provides a gain of -1 for a net output of +1V maximum. When the input is negative-going, the inputs to QA303 are summed to provide a net output of +1V maximum.

3. Adjustments. Potentiometer R305 is an internal calibration control for adjustment of amplifier zero. Potentiometer R307 is an internal calibration control for adjustment of gain in the summing amplifier QA303.

4-3. ANALOG-TO-DIGITAL CONVERTER. (Refer to schematics 25776D, 25778E). The a-to-d converter operates on a charge balancing principle. The circuit operates only with unipolar inputs. A block diagram of the converter is shown in Figure 29. The positive output of the polarity detector circuit drives the integrator amplifier QA304 negative. The integration rate is determined by the input level, resistors RN304A and RN304B and capacitor C308. As the integrator goes negative, the threshold detector (amplifier QA305) output goes to a positive level. A positive level represents a logic "1" at the "J" input of the J-K flip-flop (the "K" input is a logic "0"). The charge and discharge periods for the integrator are determined by the state of the Q output on the J-K flip-flop. When the Q output is high, diode QA306 D is back biased off and the integrator can only be charged by the polarity detector output. When the Q output is low, diode QA306-D is forward biased and discharge of the integrator is possible. Since the Q and Q states can be changed only when a clock pulse is present, the charge/discharge periods are a function of the clock frequency. The a-to-d conversion cycle is free-running and has a timing period of 2016 counts. The digital reading is derived by counting clock pulses in the discharge period. For example, a 1 volt input would result in a total count of 1000 clock pulses. One complete conversion cycle is 2048 counts. In addition to the timing period of 2016 counts, the remaining 32 counts are needed to stop the BCD counter, strobe the BCD counter information into latches, reset the BCD counter to zero, and initiate uprange or downrange (or overrange). The conversion rate is approx. 0.2 secs/conversion (2048 counts at a 10 kHz clock rate).

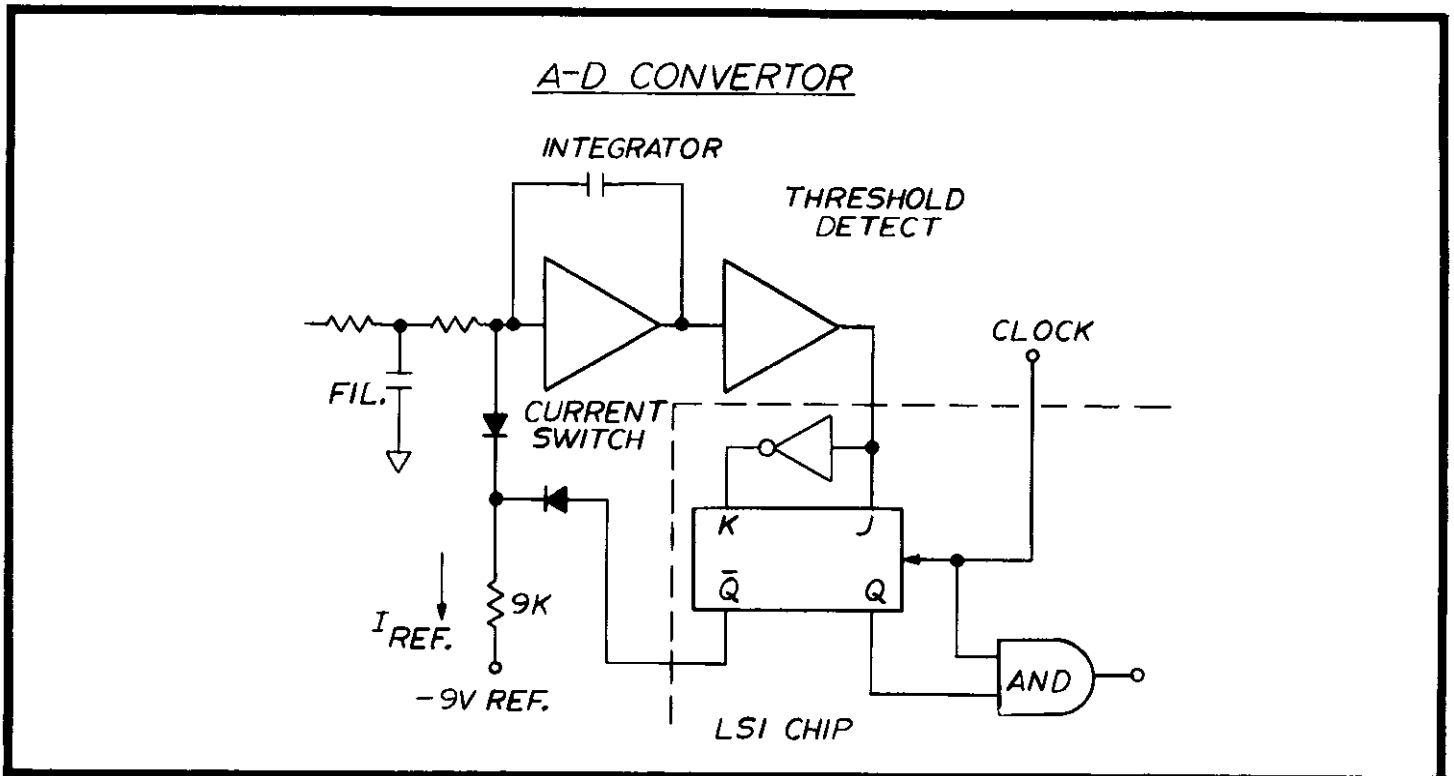

FIGURE 29. Functional Block Diagram of A-to-D Converter.

4-4. AUTO-RANGING CIRCUIT. (Refer to schematic 25778E). This circuit is located on the LSI module (QA408) with exception of decoding diodes D301A through D301H and FET switches Q302 through Q305. The threshold input (TH) and current switch (CS) signals are used to determine the proper range. Ranging is bidirectional so that upranging or downranging to an adjacent range occurs. The auto-ranging feature is defeated by grounding pin 6 (MR) on LSI QA408.

4-5. DISPLAY DRIVE. The 616 display is composed of four LED, 7-segment readouts plus a polarity/over-range readout. The display drive circuit is multiplexed so that only eight lines are driven at a time.

a. Multiplexing Circuit. This circuit is contained in the LSI QA208. The display is controlled by the four multiplexing lines which turn on the anodes of each seven segment readout. Four of the lines are used for each of the four digits. Polarity, decimal point, and dummy zero (on the .01000V range) are not multiplexed. QA401A through QA401D are used to provide sufficient drive for transistors Q405 through Q407 respectively. Each anode of each LED readout is pulled up to approx. +10 volts to light a particular digit.

b. Display Coding. Each display module has separate cathode connections for each segment as given in Table 4-5.

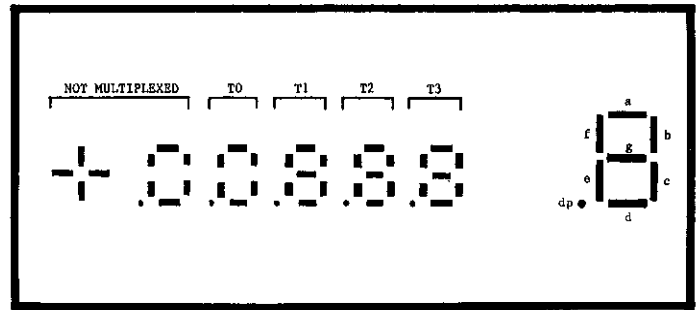

FIGURE 31. Digital Display.

TABLE 4-5. Display Coding

Numeral	Segments	Pins
0	A,B,C,D,E,F	1,13,10,8,7,2
1	B,C,	13,10
2	A,B,D,E,G	1,13,8,7,11
3	A,B,C,D,G	1,13,10,8,11
4	B,C,F,G	13,10,2,11
5	A,C,D,F,G	1,10,8,2,11
6	A,C,D,E,F,G	1,10,8,7,2,11
7	A,B,C	1,13,10
8	A,B,C,D,E,F,G	1,13,10,8,7,2,11
9	A,B,C,E,F,G	1,13,10,7,2,11
decimal	decimal	6

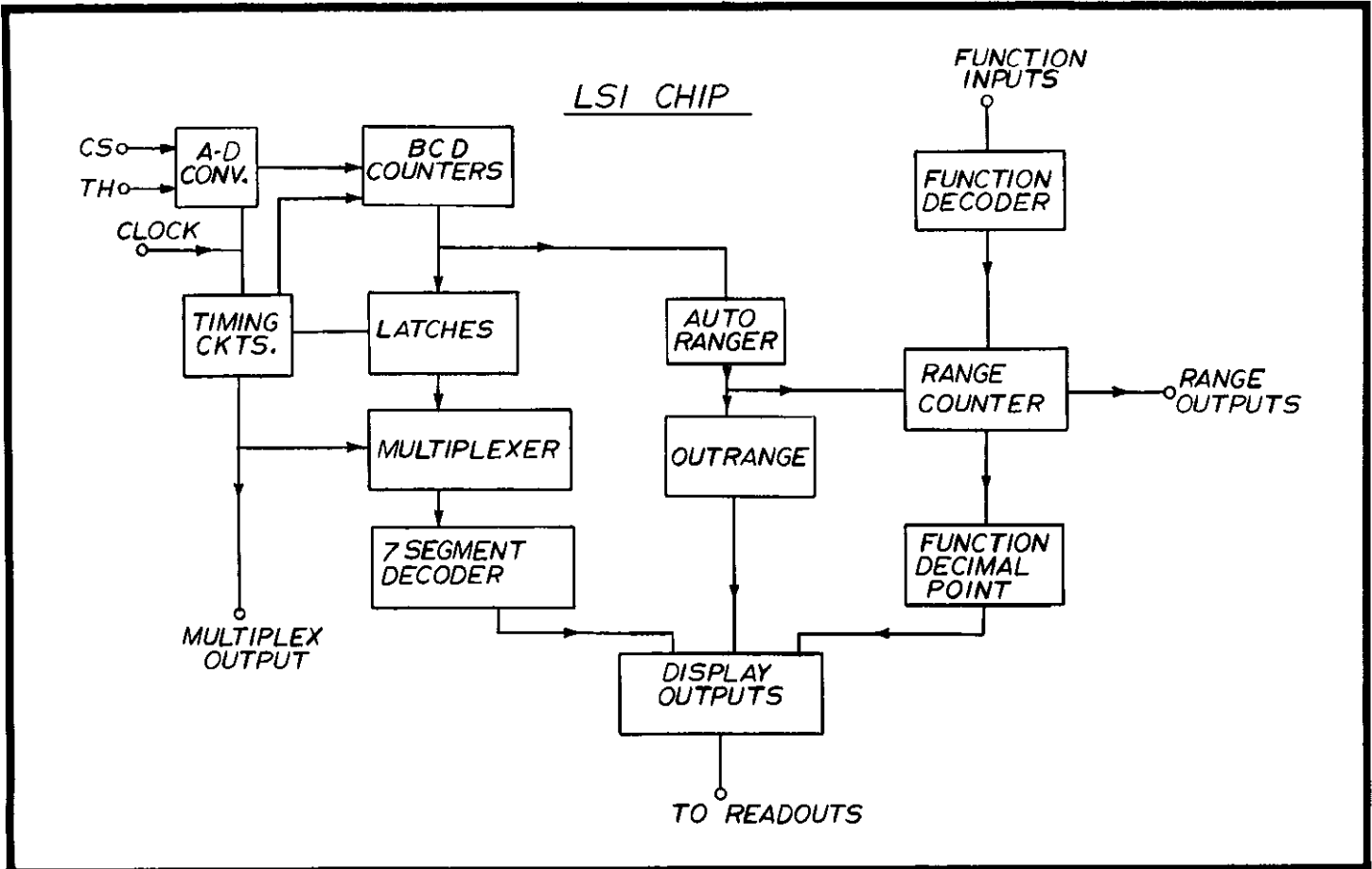

FIGURE 30. Functional Block Diagram of Large Scale Integrated Circuit.

c. Decimal Point (Sensitivity) Coding. Three coded lines are used to generate the decimal point drive. The lines are designated R_1 , R_2 , and R_4 . Inverters QA404A,C,E provide a logic "1" state for a corresponding logic "0" state (closure to LO) on any of the lines. When used in the AUTO mode, a fourth line is used to defeat the automatic ranging circuit. The remote enable line (MR) is activated when a connection to LO is made at pin 6 (MR) on LSI OA408. A truth table for decimal point logic is given in Table 4-6.

TABLE 4-6.
Decimal Point Coding

Sensitivity Setting	R_4	R_2	R_1
.01000	0	X	X
.1000	1	0	0
1.000	1	0	1
10.00	1	1	0
100.0	1	1	1

d. Overrange Indication. Overrange is indicated by diode network DN403. Transistor Q403 controls the cathodes for segments A,D,F,E to display a "0". When transistor Q403 is turned off, the display indicates a "1" since segments B and C are always turned on (pins 10 and 13 are connected to LO).

e. Dummy "0" Indication. When the 10 millivolt range is selected, the 616 display indicates a fifth digit (DN402) and decimal point. Transistor Q402 controls the cathodes for segments A,B,C,D,F,E to display a "0". Transistor Q402 is turned off when R_4 is high (QA404A = low).

f. Polarity Indication. The polarity display DN401 is controlled by transistor Q401. The minus sign is always lighted. Additional segments are turned on for the plus sign.

g. Overload Indication. The LSI module (QA408) contains additional circuitry for overload blanking of the display. When the display exceeds 200 volts, the circuit causes a blinking action of the three least significant digits. The display reads properly up to 201.7 volts (001.7 max.).

4-6. REFERENCE OSCILLATOR. The reference frequency (clock) circuit is composed of integrated circuit QA406 and other fixed components forming a free-running oscillator. The oscillator operates at frequency of approx. 10 kHz. The output of transistor Q411 is a clock pulse between -0.7 volt and +5 volts dc with a 5 microsecond pulse width.

4-7. MISCELLANEOUS CIRCUITS USED FOR 6162. These circuits are used to generate signals or signal levels for the Model 6162 Isolated Output/Control.

a. Gated Clock. This circuit is composed of inverters QA405D,E,F and NAND gates QA407A,B,C. The circuit combines signals from the LSI module and clock to provide a gated clock "GC". This signal and "CN" are used to generate BCD outputs in the Model 6162.

b. Decimal Point. This circuit is composed of inverter stages QA405A,B,C which provide sufficient drive for optical isolators in the Model 6162. Decimal point is coded in three lines R_4 , R_2 , R_1 as shown in Table 4-6.

4-8. POWER SUPPLIES (Schematic 25777D).

a. Primary Power. The Model 616 can be operated over two ranges of line voltage. Switch S201 has two line voltage positions as follows:

117V: 90V - 125V rms range
234V: 180V - 250V rms range } 50-60 Hz, 9W

Fuse (F201) must be selected for each line voltage range as follows:

117V: 3/16 ampere, 3AG SLO-BLO
234V: 1/10 ampere, 3AG SLO-BLO

b. Secondary Power. The Model 616 power supply is composed of four separate supplies. Transformer T201 provides four center-tapped secondary windings.

1. $\pm 275V$ Unregulated. This supply taps a-c power from secondary windings 1-2-3 of T201. Diodes D201 through D204 form voltage-doubling supplies. Output voltage is approximately 275 volts at 2 milliamperes (at nominal line voltage). Ripple is approximately 2 volts peak-to-peak at no load.

2. $\pm 12V$ Regulated. This supply taps a-c power from secondary windings 6-7-8 of T201. D205 is a four-diode full-wave bridge. Integrated circuit QA201 provides a regulated ± 12 volts at 10 milliamperes. Ripple is approximately 1 millivolt peak-to-peak at nominal loading.

3. -9V Regulated. This supply also utilizes D205 for full-wave rectification. Zener diode D206 provides a regulated voltage of -9V at 5 milliamperes. Ripple is approximately 3 millivolts peak-to-peak.

4. +5V Regulated. This supply taps a-c power from secondary windings 9-10-11 of T201. Diodes D207 and D208 form a full-wave rectifier. Integrated circuit QA203 provides a regulated output of +5 volts at 200 milliamperes. Ripple is approximately 1 millivolt peak-to-peak.

5. +10V Unregulated. This supply utilizes the unregulated output of the full-wave rectifier D207-D208. Ripple is approximately 1 volt peak-to-peak at 200 milliamperes loading.

6. -12V Regulated. This supply taps a-c power from secondary windings 13-14-15 of T201. Diodes D209 and D210 form a full-wave rectifier. Integrated circuit QA202 is a regulator element. Transistor Q201 is a series-pass regulator. Output voltage is -12V at 50 milliamperes. Ripple is approximately 2 millivolts peak-to-peak.

TABLE 4-7.
Pin Identification for LSI

Pin No.	Designation	Function	Voltage Levels
1	F	Segment drive	+5V = ON, 0V = OFF
2	G	Segment drive	+5V = ON
3	T1	Multiplex Line	+5V = ON
4	T3	Multiplex Line	+5V = ON
5	HOLD	Display hold	+5V = HOLD
6	MR	Range Enable	0V = inhibit autoranging
7	TH	Threshold input	+5V or -12V
8	CLK	Clock Pulse	Approx. 10kHz, +5V to -1V
9	B	Segment drive	+5V = ON
10	A	Segment drive	+5V = ON
11	D	Segment drive	+5V = ON
12	E	Segment drive	+5V = ON
13	C	Segment drive	+5V = ON
14	CS	Current Switch	+5V = integrate mode
15	DP	No connection	---
16	÷44	No connection	---
17	TO	Multiplex line	+5V = ON
18	F1	---	0V
19	F4	---	+5V
20	+5	Power	+5V
21	-12	Power	-12V
22	LOW	Common	0V
23	CN	Count Now	+5V = 2016 counts
24	TZ	Multiplex line	+5V = ON
25	R4	Range Line	See Table 4-6.
26	R1	Range Line	
27	R2	Range Line	
28	F2	---	

4-9. DIGITAL OUTPUT (Refer to schematic no's 25715D, 25716D, 25717C, and 25823C).

a. Isolation Circuitry. Isolation of electrometer LO and digital output LO is achieved through the use of an optically coupled isolator for each signal transmitted between the 616 and 6162. The isolators are NPN types and provide greater than $10^{10}\Omega$ isolation resistance. The anodes of all light emitting diodes are connected to +5 volts. The diode conducts whenever the cathode is connected low (a 330 Ω current limit resistor is used with each input). The output of each isolator transistor is connected in a ground-emitter or emitter-follower configuration.

b. Decade Counters. The Model 6162 utilizes three decade counter stages QA201, QA202, and QA203 for "1", "10", and "100" respectively. Each integrated circuit provides BCD information using four lines identified as 1×10^n , 2×10^n , 4×10^n , and 8×10^n .

c. Storage Registers. Individual storage registers are used to control data flow to the output buffer stages. Integrated circuits QA205, QA206, and QA207 are enabled by the output of QA223A (ENB).

d. Buffered Output Stage. Each buffer is composed of a Keithley Part No. IC-22 NAND gate (four gates per circuit module). The buffers utilize "open collector" output transistors. Each circuit module is connected to an individual STROBE control for mon-

itoring two or more 6162 outputs connected to a single output bus. Each set of four buffers is enabled whenever the Strobe line is pulled down to digital low. Each STROBE circuit consists of an inverter stage (Keithley IC-32), a 4.7 kilohm pull-up resistor, and a protection diode (Keithley RF-39).

e. Print Rate Control. Print rate for the Model 6162 consists of a timing circuit composed of integrated circuit QA108, resistor R116, potentiometer R115 and capacitor C101. Potentiometer R115 permits continuous control of Print Rate from 1/5 second per reading to 7 seconds per reading. The Print Rate control has no effect on the Model 616 display rate.

f. Flag Circuitry. The Flag output is generated by integrated circuit QA108. The output of buffer stage QA222C is high for a length of time established by the Print Rate Control. No change in the digital output is made during the interval when Flag is high. (Flag is low).

g. BCD Hold Circuit. This circuitry inhibits the Enable pulse which in turn holds the information in the storage registers. The Hold is activated whenever D101 is closed to output low. Integrated circuit QA109 is a flip-flop which is set by CN.

h. Display Hold. This circuitry controls the display driver in the Model 616. The Display Hold is activated whenever D102 is closed to output low.

SECTION 5. ACCESSORIES

5-1. GENERAL. The following Keithley accessories can be used with the Model 616 to provide additional convenience and versatility.

5-2. OPERATING INSTRUCTIONS. A separate Instruction Manual is supplied with each accessory giving complete operating information.

Model 6101A Shielded Probe

Description:

The Model 6101A is a shielded cable with a needle-point probe and 30 inches of low noise cable terminated by a UHF connector.



Model 6101B Shielded Probe

Description:

The Model 6101B is a shielded cable with a "gripping type" probe and 30 inches of low noise cable terminated by a UHF connector.

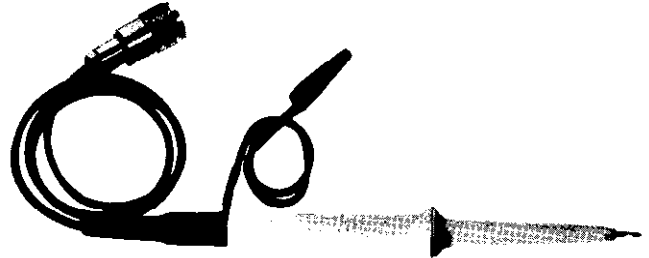

Model 6103C Divider Probe

Description:

The Model 6103C is a shielded cable with a needle-point probe and 30 inches of low noise cable terminated by a UHF connector. The probe includes a 1000:1 voltage divider with a $4.5 \times 10^{11} \Omega$ resistance. Accuracy is $\pm 5\%$ at 30 kilovolts.

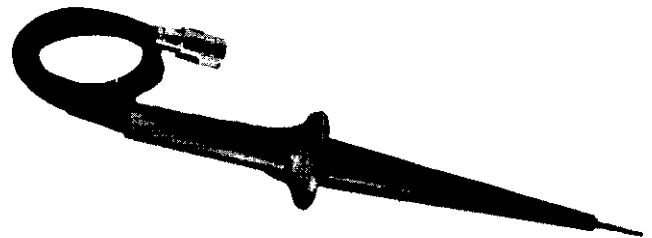

Model 6102A Divider Probe

Description:

The Model 6102A is a shielded cable with a needle-point probe and 30 inches of low noise cable terminated by a UHF connector. The probe includes a 10:1 voltage divider with $10^{10} \Omega$ input resistance. Accuracy is $\pm 4\%$ at 1000 volts.

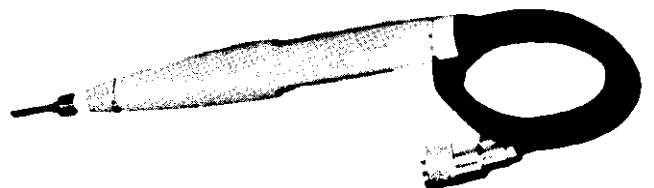

Model 6011 Input Cable

Description: The 6011 is a low-noise triaxial cable, 30" long, terminated by three color-coded alligator clips. This cable mates directly with the triaxial input. The cable is fabricated using a Keithley part no. CS-141 connector and part no. SC-22 low-noise cable.

Application: The 6011 may be used for measurements which require a triaxial connection, especially when the input LO is floated above CASE ground.



Model 6301 Guarded Probe

Description: The 6301 is a guarded triaxial cable, 3 ft. long, terminated by a probe for making point-to-point measurements.

Application: The 6301 may be used for measurements which require a triaxial cable with a guarded probe having an insulation resistance greater than 10^{14} ohms.



Model 1531 Gripping Probe

Description: The 1531 is a triaxial cable, 3 ft. long, terminated by a special gripping-type probe. The 1531 insulation resistance is greater than 10^{10} ohms. The probe is rated for off ground measurements up to 500 v

Application: The 1531 may be used for measurements which require a triaxial cable. The probe permits convenient connections to the circuit under test due to the gripping feature.

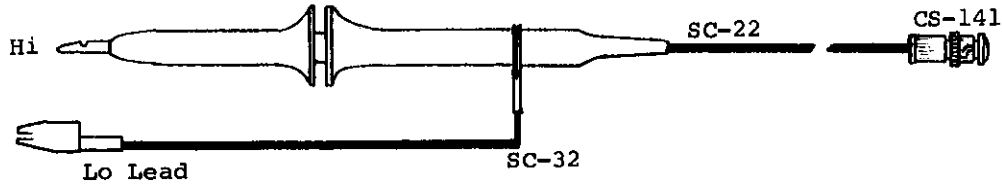

Model 6012 Triax-to-Coax Adapter

Description: The 6012 is an adapter for mating the triaxial input and UHF (coax) type connectors. This adapter can be used with Models 6101A, 6101B, 6103B, 6102A, etc.

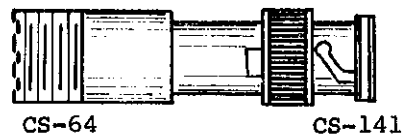

Model 6106 Electrometer Connection Kit

Description:

The Model 6106 contains a group of the most useful leads and adapters for low current measurements. All components are housed in a rugged carrying case with individual compartments.

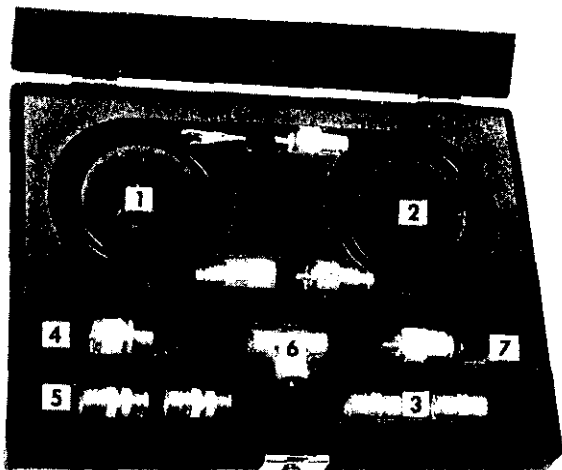

Parts List:

Description	Item No.	Keithley Part No.
Cable, 30", UHF to clips	1	19072C
Cable, 24", UHF to UHF	2	18265C
Connector, UHF to UHF	3	CS-5
Adaptor, UHF to BNC	4	CS-115
Adaptor, UHF to BNC	5	CS-172
Adaptor Tee, UHF to UHF	6	CS-171
Adaptor, Binding Post	7	19071B

The two cables (Items 1 and 2) are coaxial shielded leads useful for connections where low noise is essential. The 24" cable (Item 2) can be used to interconnect two instruments having UHF receptacles. The 30" cable (Item 1) can be used to connect to the circuit under test through the use of clip leads. A binding post adapter gives easy access to the electrometer "high" terminal. Two UHF femal couplers (Item 3) permit cables to be connected together. The UHF "tee" connector simplifies galvanometric current measurements when using a current source and electrometer or picoammeter. Adapters (Items 4 and 5) are useful for conversion from UHF to BNC terminations.

Models 2501, 2503 Static Detector Probes

Description:

The Models 2501 and 2503 are specially designed detectors used to measure static charge on plane surfaces. Either probe must be used with an electrometer

Model 2501:

The 2501 is useful for measurements of charge on flat surfaces. The static head is 3 inches in diameter. Recommended spacing is 3/8" from the surface for 10,000:1 divider ratio. The 2501 is calibrated such that a 1 volt deflection on the electrometer corresponds to 10 kilovolts of static charge.

Model 2503:

The 2503 consists of a rigid probe 1/2 inches in diameter. Operation is similar to the use of the 2501 probe.

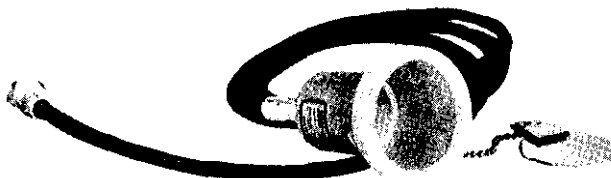

Model 6107 pH Electrode Adapter

Description:

The Model 6107 is a test fixture which simplifies connections to the electrometer when making pH measurements. The adapter can be used with electrodes manufactured by Leeds & Northrup, Coleman and Beckman. The 6107 can be used for guarded measurements as shown in the diagram. A voltage-to-pH conversion chart is supplied with the 6107.

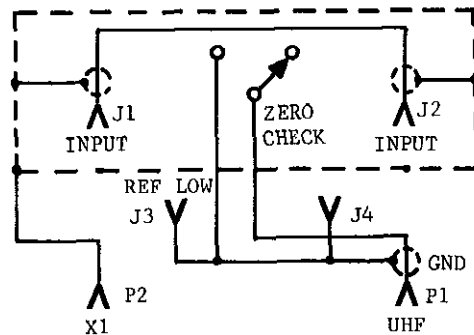

Model 6104 Test Shield

Description:

The Model 6104 is a shielded test box for two-terminal or three-terminal connections. The INPUT terminal is teflon insulated.

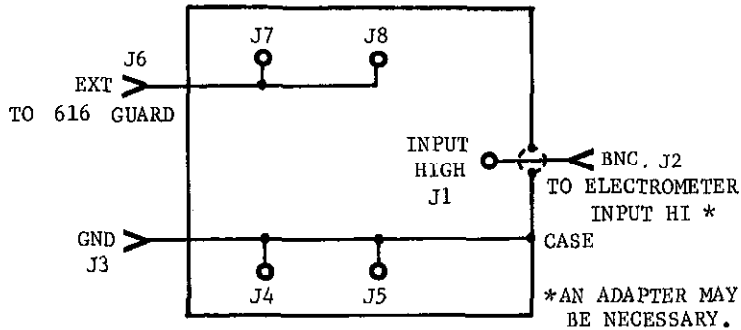

Applications:

1. Two Terminal Connections. Resistance measurements can be made conveniently using the INPUT and GROUND terminals on the Test Box. Connect the electrometer to the BNC output. Use the electrometer in NORMAL mode for ohms measurement.
2. Three Terminal Connections. The GUARD output on the Model 616 electrometer can be used for resistance measurements where the effects of cable capacitance may be significant. Connect the unknown between INPUT and EXT terminals. Connect the EXT terminal to the GUARD output on the electrometer. Use the electrometer in FAST mode for ohms measurement.

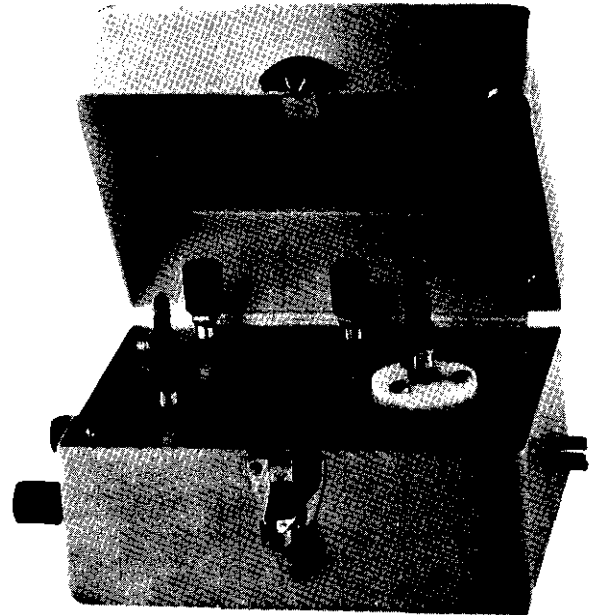

Model 6105 Resistivity Chamber

Description:

The Model 6105 is a guarded test fixture for measurement of surface and volume resistivities. The chamber is designed in accordance with ASTM Standard Method of Test for Electrical Resistance of Insulating Materials, D257-66. The 6105 can be used in conjunction with an electrometer and voltage supply.

Applications:

Resistivity can be determined by measuring the current through a sample with a known voltage impressed. The measurement can be made most conveniently when a set of electrodes are used which can be calibrated in terms of surface or volume resistivity. The Keithley Model 6105 Resistivity Adapter has been designed for use with a Keithley electrometer and an optional high voltage supply such as the Model 240A.

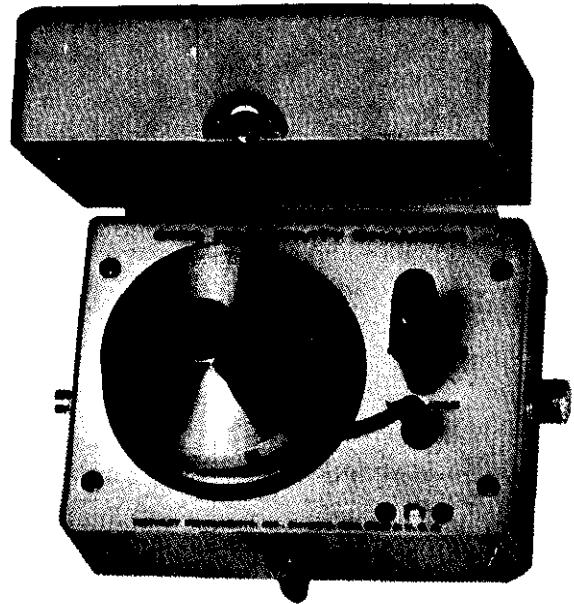

SECTION 6. MAINTENANCE

6-1. GENERAL. This section contains information necessary to maintain the instrument to published specifications.

6-2. REQUIRED TEST EQUIPMENT. Minimum requirements for test equipment are given in Tables 6-1 and 6-6.

6-3. PERFORMANCE VERIFICATION. Use the following procedure to verify proper operation of the instrument. Performance of the instrument is based on an operating temperature between 20°C and 30°C and relative humidity less than 70%.

a. Preliminary Set-up.

1. Set the Line Switch to 117 or 234V depending on the line power available.
2. Fuse Check: Verify that the appropriate line fuse is installed.

117V: 3/16 ampere, 3AG, SLO-BLO (Keithley FU-29)
 234V: 1/10 ampere, 3AG, SLO-BLO (Keithley FU-40)

3. Connect the power cord to a variable transformer which has been set to 117V ± 1V or 234V ± 2V depending on the line power available.

4. Connect the shorting link (on the rear panel) between LO and GROUND. For maximum operator safety, make certain that the chassis is connected to earth ground by way of the third conductor on the line cord or by way of a separate clip lead from GROUND to earth ground.

5. Turn the instrument power on and allow the instrument to stabilize at ambient temperature for at least 1/2 hour. Record the temperature so that temperature coefficients can be utilized as necessary.

b. Voltage Accuracy Check.

1. Select NORMAL mode and VOLT function.
2. Select the AUTO SENSITIVITY mode.
3. Place ZERO CHECK switch on. The display should indicate .00000 volts. If necessary, adjust the front panel ZERO control to obtain a zero reading with the polarity indicator blinking on and off.
4. Place ZERO CHECK switch off.
5. Apply dc voltages to the input of the Model 616 as given in Table 6-2 using Voltage Source (A).

TABLE 6-2.
Voltage Accuracy Check

Source Input	Source Accuracy	Display Reading	Reading Tolerance
10 mV	0.03%	.01000 V	±3 digits
100 mV	0.03%	.1000 V	±3 digits
1 V	0.03%	1.000 V	±3 digits
10 V	0.03%	10.00 V	±3 digits
100 V	0.03%	100.0 V	±3 digits

TABLE 6-1.
Required Test Equipment for Verification.

Item	Description	Specification	Mfr. and Model
A	Voltage Source (DC), 10mV to 100V in decade steps (For 10mV range use 10:1 divider)	±0.03% accuracy	Fluke, Model 341A GR 1455BH (divider for 10mV)
B	Resistance Source, 10 ⁵ Ω to 10 ¹² Ω in decade steps	±0.05%, 10 ⁵ Ω to 10 ⁷ Ω ±0.2%, 10 ⁸ Ω ±0.5%, 10 ⁹ Ω to 10 ¹² Ω	GR 1433, Keithley Model 5155
C	Current Source, 10 ⁻¹ A to 10 ⁻⁴ A	±0.05%, 10 ⁻¹ A to 10 ⁻⁴ A	Fluke, Model 3330B
D	Current Source, 10 ⁻⁵ A to 10 ⁻⁷ A Ranges	±0.05%, 10 ⁻⁵ A to 10 ⁻⁷ A	Fluke, Model 341A, and GR1433 See Note 1.
E	Current Source, 10 ⁻⁸ to 10 ⁻¹¹ A	0.2%, 10 ⁻⁸ A 0.6%, 10 ⁻⁹ A to 10 ⁻¹¹ A	Keithley Model 261. <i>3 mV range</i>

NOTE 1.

To verify the accuracy on the 10⁻⁵A to 10⁻⁷A ranges, a Model 341A should be used with precision resistors having ±0.02% accuracy.

c. Resistance Accuracy Check.

1. Select NORMAL mode.
2. Select the 1 VOLT SENSITIVITY mode.
3. Select the 10^5 ohm range.
4. Apply 10^5 ohms using Resistance Source (B).
5. Verify that the reading on the display is within ± 6 digits.
6. Check the remaining ranges in accord with Table 6-3.

TABLE 6-3.
Resistance Accuracy Check

Source Input	Source Accuracy	Range	Display Reading	Reading Tolerance
$10^5 \Omega$	$\pm 0.05\%$	$10^5 \Omega$	$1.000 \times 10^5 \Omega$	± 6 digits
$10^6 \Omega$	$\pm 0.05\%$	$10^6 \Omega$	$1.000 \times 10^6 \Omega$	± 6 digits
$10^7 \Omega$	$\pm 0.05\%$	$10^7 \Omega$	$1.000 \times 10^7 \Omega$	± 6 digits
$10^8 \Omega$	$\pm 0.2\%$	$10^8 \Omega$	$1.000 \times 10^8 \Omega$	± 21 digits
$10^9 \Omega$	$\pm 0.5\%$	$10^9 \Omega$	$1.000 \times 10^9 \Omega$	± 51 digits
$10^{10} \Omega$	$\pm 0.5\%$	$10^{10} \Omega$	$1.000 \times 10^{10} \Omega$	± 51 digits
$10^{11} \Omega$	$\pm 0.5\%$	$10^{11} \Omega$	$1.000 \times 10^{11} \Omega$	± 51 digits
$10^{12} \Omega$	$\pm 0.5\%$	$10^{12} \Omega$	$1.000 \times 10^{12} \Omega$	± 51 digits

d. Current Accuracy Check.

1. Select NORMAL mode.
2. Select 1 VOLT SENSITIVITY.
3. Select 10^{-1} ampere range.
4. Apply 10^{-1} ampere using Current Source (C).
5. Verify that the reading on the display is within ± 6 digits.

6. Check the $10^{-1}A$ to $10^{-4}A$ ranges in accord with Table 6-4.

7. Select FAST mode for verification of $10^{-5}A$ to $10^{-11}A$ ranges.

8. Check the $10^{-5}A$ to $10^{-11}A$ ranges using Current Source (D) and (E).

9. Verify ranges in accord with Table 6-4.

TABLE 6-4.
Current Accuracy Check.

Source Input	Source Accuracy	Range	Display Reading	Reading Tolerance
$10^{-1} A$	$\pm 0.05\%$	$10^{-1} A$	$1.000 \times 10^{-1} A$	± 6 digits
$10^{-2} A$	$\pm 0.05\%$	$10^{-2} A$	$1.000 \times 10^{-2} A$	± 6 digits
$10^{-3} A$	$\pm 0.05\%$	$10^{-3} A$	$1.000 \times 10^{-3} A$	± 6 digits
$10^{-4} A$	$\pm 0.05\%$	$10^{-4} A$	$1.000 \times 10^{-4} A$	± 6 digits
$10^{-5} A$	$\pm 0.05\%$	$10^{-5} A$	$1.000 \times 10^{-5} A$	± 6 digits
$10^{-6} A$	$\pm 0.05\%$	$10^{-6} A$	$1.000 \times 10^{-6} A$	± 6 digits
$10^{-7} A$	$\pm 0.05\%$	$10^{-7} A$	$1.000 \times 10^{-7} A$	± 6 digits
$10^{-8} A$	$\pm 0.2\%$	$10^{-8} A$	$1.000 \times 10^{-8} A$	± 21 digits
$10^{-9} A$	$\pm 0.6\%$	$10^{-9} A$	$1.000 \times 10^{-9} A$	± 51 digits
$10^{-10} A$	$\pm 0.6\%$	$10^{-10} A$	$1.000 \times 10^{-10} A$	± 51 digits
$10^{-11} A$	$\pm 0.6\%$	$10^{-11} A$	$1.000 \times 10^{-11} A$	± 51 digits

e. Coulombs Accuracy Check.

1. Select FAST mode.
2. Select 1 VOLT SENSITIVITY.
3. Apply an input current in decade steps from 10^{-8} ampere to 10^{-11} ampere in accordance with Table 6-5. (Display should read zero with "ZERO CHECK" switch open. If not, close "ZERO CHECK" switch for short period of time.)
4. Verify that the integration time to reach a 1.000 volt display is 10 seconds $\pm 1/2$ second.

TABLE 6-5.
Coulombs Accuracy Check.

Source Input	Source Accuracy	Range	Display Reading	Time to Reading	Tolerance
$10^{-8} A$	$\pm 0.5\%$	$10^{-7} Q$	$1.000 \times 10^{-7} Q$	10 secs.	$\pm 1/2$ sec.
$10^{-9} A$	$\pm 0.5\%$	$10^{-8} Q$	$1.000 \times 10^{-8} Q$	10 secs.	$\pm 1/2$ sec.
$10^{-10} A$	$\pm 0.5\%$	$10^{-9} Q$	$1.000 \times 10^{-9} Q$	10 secs.	$\pm 1/2$ sec.
$10^{-11} A$	$\pm 0.5\%$	$10^{-10} Q$	$1.000 \times 10^{-10} Q$	10 secs.	$\pm 1/2$ sec.

6-4. ADJUSTMENT AND CALIBRATION. This procedure should be used whenever it is necessary to calibrate the instrument to ensure that it meets published specifications. Calibration may be accomplished every 12 months to ensure accuracy over long-term use or more frequently if desired.

a. Test Equipment. The test equipment recommended in Table 6-6 should be used to ensure proper results. Other equipment may be substituted if specifications meet or exceed those given.

b. Environment. The calibration should be performed in a controlled environment. The factory calibration is performed at approximately 25°C temperature and less than 50% relative humidity. Recommended temperature range for calibration is 23°C to 27°C.

c. Preliminary Set-up.

1. Set the Line Switch to 117 or 234V depending on the line power available.
2. Fuse Check: Verify that the appropriate line fuse is installed.

117V: 3/16 ampere, 3AG, SLO-BLO (Keithley FU-29)
 234V: 1/10 ampere, 3AG, SLO-BLO (Keithley FU-40)

3. Connect the power cord to a variable transformer which has been set to 117V ± 1V or 234V ± 2V depending on the line power available.

4. Connect the shorting link (on the rear panel) between LO and GROUND. For maximum operating safety, make certain that the chassis is connected to earth ground by way of the third conductor on the line cord or by way of a separate clip lead from GROUND to earth ground.

5. Turn the instrument power on and allow the instrument to stabilize at ambient temperature for at least 1/2 hour. Record the temperature so that temperature coefficients can be utilized as necessary.

d. Power Supply Check. This procedure verifies that the power supply voltages are within nominal tolerances. No adjustments are required.

1. Measure the supply voltage at the test points given in Table 6-7 using Voltmeter (F).

2. Verify the reading for each voltage.

e. Voltage Calibration. (Select NORMAL mode for all Measurements.)

1. Front Panel Zero.

a). Place ZERO CHECK to on.

b). Select 10mV SENSITIVITY.

c). Monitor the X1 output (J118) using Voltmeter (F).

d). Reading on Voltmeter (F) should be .000 ±.010mV dc.

e). Adjust front panel ZERO (R119) as necessary.

NOTE

If the front panel ZERO control does not provide enough adjustment capability, the internal potentiometer R123 should be adjusted. (Located on small pc board inside shielded input compartment.)

2. A-D Input Zero.

a). Place ZERO CHECK to on.

b). Select 10mV SENSITIVITY.

c). Monitor the 1V output (J117) using Voltmeter (F).

d). Reading on Voltmeter (F) should be 00.0 ±1.0mV dc.

e). Adjust potentiometer R311 (A-D INPUT ZERO) as necessary.

TABLE 6-6.
 Required Test Equipment for Calibration.

Item	Description	Specification	Mfr. and Model
F	Voltmeter, 3-1/2 digits, 1µV resolution	±0.2% accuracy	Keithley Model 160
G	Oscilloscope (Used for power supply check)	1mV/division ac coupled	Tektronix, Model 561A
H	Voltage Source (DC) ±5mV	±1% accuracy	Keithley Model 260
I	Voltage Source (DC), 10mV to 100V in decade steps (For 10mV range use 10:1 divider)	±0.03% accuracy	Fluke, Model 341A GR 1455BH (divider for 10mV)
J	Resistance Source, 10 ⁵ Ω	±0.02% accuracy	General Radio, Model 1433

TABLE 6-7.
Power Supply Check

Voltage	Test Point	Tolerance	Pk-to-Pk Ripple	Line Regulation 90V - 125V AC
+5V	TP4	±250mV	<1mV	±10mV
+10V	+10V Unreg.	+7.5V to +11V	<1V	Unregulated
-12V	TP5	±600mV	<2mV	±10mV
-9V	TP2	±450mV	<4mV	±150mV
+12V	TP3	±600mV	<4mV	±10mV
+275V	+275V Unreg.	+205 to +300V	<3V	Unregulated
-275V	-275V Unreg.	-205 to -300V	<3V	Unregulated

3. Display Zero.

- a). Place ZERO CHECK to off.
- b). Select 1V SENSITIVITY.
- c). Apply +5 millivolts dc ±1% using Voltage Source (H).
- d). Reading on Model 616 should be +0.005 ±0 digits.
- e). Adjust potentiometer R308 (DISPLAY ZERO) as necessary.

4. Rectifier Zero.

- a). Select 1V SENSITIVITY.
- b). Apply -5 millivolts dc ±1% using Voltage Source (H).
- c). Reading on Model 616 should be -0.005 ±0 digits.
- d). Adjust potentiometer R305 (RECT. ZERO) as necessary.

NOTE

If an adjustment of potentiometer R305 is required, repeat steps 3 and 4 until both readings are obtained without further adjustment.

5. +DC CAL.

- a). Select 1V SENSITIVITY.
- b). Apply +1V dc ±0.03% using Voltage Source (I).
- c). Reading on Model 616 should be +1.000 ±0 digit.
- d). Adjust potentiometer R309 (+DC CAL) as necessary.

NOTE

The +DC CAL must be performed (in the order given) before the -DC CAL to obtain proper calibration.

6. -DC CAL.

- a). Select 1V SENSITIVITY.

- b). Apply -1V dc ±0.03% using Voltage Source (I).

- c). Reading on Model 616 should be -1.000 ±0 digit.

- d). Adjust potentiometer R307 (-DC CAL) as necessary.

7. 10mV RANGE ADJ.

- a). Select 10mV SENSITIVITY.

- b). Apply +10mV dc ±0.03% using Voltage Source (I) (with 10:1 divider).

- c). Reading on Model 616 should be +.01000 ±1 digit.

- d). Adjust potentiometer R303 (10mV RANGE ADJ.) as necessary. (This control has an adjustment range of approx. -0μV to +100μV.)

NOTE

The front panel ZERO control may have to be adjusted in ZERO CHECK prior to this adjustment to eliminate an error due to zero offset.

8. 100V RANGE ADJ.

- a). Select 100V SENSITIVITY.

- b). Apply +100.0V dc ±0.03% using Voltage Source (I).

- c). Reading on Model 616 should be +100.0V ±1 digit.

- d). Adjust potentiometer R304 (100V RANGE ADJ.) as necessary.

f. Resistance Calibration.

- 1. Select 1V SENSITIVITY.

- 2. Select 10⁵Ω range.

- 3. Apply a resistance of 100 kilohms ±0.02%.

- 4. Reading on the Model 616 should be 1.000 x 10⁵Ω ±0 digit.

- 5. Adjust potentiometer R114 (OHMS CAL) as necessary.

SECTION 7. REPLACEABLE PARTS

7-1. REPLACEABLE PARTS LIST: This section contains a list of components used in this instrument for user reference. The Replaceable Parts List describes the individual parts giving Circuit Designation, Description, Suggested Manufacturer (Code Number),

Manufacturer's Part Number, and the Keithley Part Number. Also included is a Figure Reference Number where applicable. The complete name and address of each Manufacturer is listed in the CODE-TO-NAME Listing, Federal Supply Code, Handbook H 4-2.

TABLE 7-1.
Abbreviations and Symbols

A	ampere	F	Farad	Ω	ohm
CbVar	Carbon Variable	Fig	Figure	p	pico (10 ⁻¹²)
CerD	Ceramic Disc	Gcb	Glass enclosed Carbon	PC	Printed Circuit
Cer Trimmer	Ceramic Trimmer	k	kilo (10 ³)	Poly	Polystyrene
Comp	Composition	μ	micro (10 ⁻⁶)	Ref.	Reference
DCb	Deposited Carbon	M	Meg (10 ⁶)	TCu	Tinner Copperweld
Desig.	Designation	Mfr.	Manufacturer	V	volt
EAL	Electrolytic, Aluminum	MtF	Metal Film	W	watt
ETB	Electrolytic, tubular	My	Mylar	WW	Wirewound
ETT	Electrolytic, tantalum	No.	Number	WWVar	Wirewound Variable

7-2. ELECTRICAL SCHEMATICS AND DIAGRAMS. Schematics and diagrams are included to describe the electrical circuits as discussed in Section 4.

Sales Service Department, Keithley Instruments, Inc. or your nearest Keithley representative.

b. When ordering parts, include the following information.

7-3. HOW TO USE THE REPLACEABLE PARTS LIST. This Parts List is arranged such that the individual types of components are listed in alphabetical order. Main Chassis parts are listed followed by printed circuit boards and other subassemblies.

1. Instrument Model Number.
2. Instrument Serial Number.
3. Part Description.
4. Schematic Circuit Designation.
5. Keithley Part Number.

7-4. HOW TO ORDER PARTS.

c. All parts listed are maintained in Keithley Spare Parts Stock. Any part not listed can be made available upon request. Parts identified by the Keithley Manufacturing Code Number 80164 should be ordered directly from Keithley Instruments, Inc.

a. Replaceable parts may be ordered through the

TABLE 7-2.
Schematic Diagrams

Description	Schematic No.
Electrometer Amp & Range Switching	25764E
Power Supply	25777D
LSI Circuit, Digital Logic & Display	25778E
Autoranging Amplifier, Integrator, Threshold Det.	25776D
Isolated Output/Control	25715D
Isolated Output/Control	25716D
Isolated Output/Control	25717C
Isolated Output/Control, Power Supply	25823C

TABLE 7-3.
Circuit Designation Series

Series	Description	Circuit Designation	Page No.
100	Electrometer Amplifier	PC-321, 361	40
200	Power Supply	PC-321	42
300	Auto-Ranging Amplifier	PC-324	44
300	Integrator, Threshold Det.	PC-324	44
400	Digital Logic & Display	PC-322, 323	45

TABLE 7-4.
Mechanical Parts List

Item No.	Description	Qty. Per Assembly	Keithley Part No.	Figure No.
--	Chassis Assembly	-	--	32
--	Front Panel Assembly	-	--	
1	Front Panel	1	25770B	
2	Screw, Slotted, 6-32 x 3/8	4	--	
3	Front Panel Overlay	1	25598B	
4	Rear Panel	1	25706B	
5	Side Extrusion Left	1	25773B	
6	Side Extrusion Right	1	25772B	
7	Corner Bracket	2	24745B	
8	Screw, Phillips, 6-32 x 1/2	4	--	
9	Screw, Phillips, 6-32 x 1/2	4	--	
10	Clip for Side Dress	2	FA-101	
11	Side Dress Panel	2	24360B	
--	Top Cover Assembly	-	--	
12	Top Cover	1	25771C	
13	Screw, Phillips, 6-32 x 5/16	4	--	
--	Bottom Cover Assembly	-	25564B	33
14	Bottom Cover	1	25563C	
15	Screw, Phillips, 6-32 x 5/16	4	--	
--	Feet Assembly	-	--	
16	Feet	4	24322B	
17	Ball	4	FE-6	
18	Tilt Bail	1	17147B	
19	Screw, Phillips, 6-32	4	--	
20	Keyp Nut, 6-32	4	--	

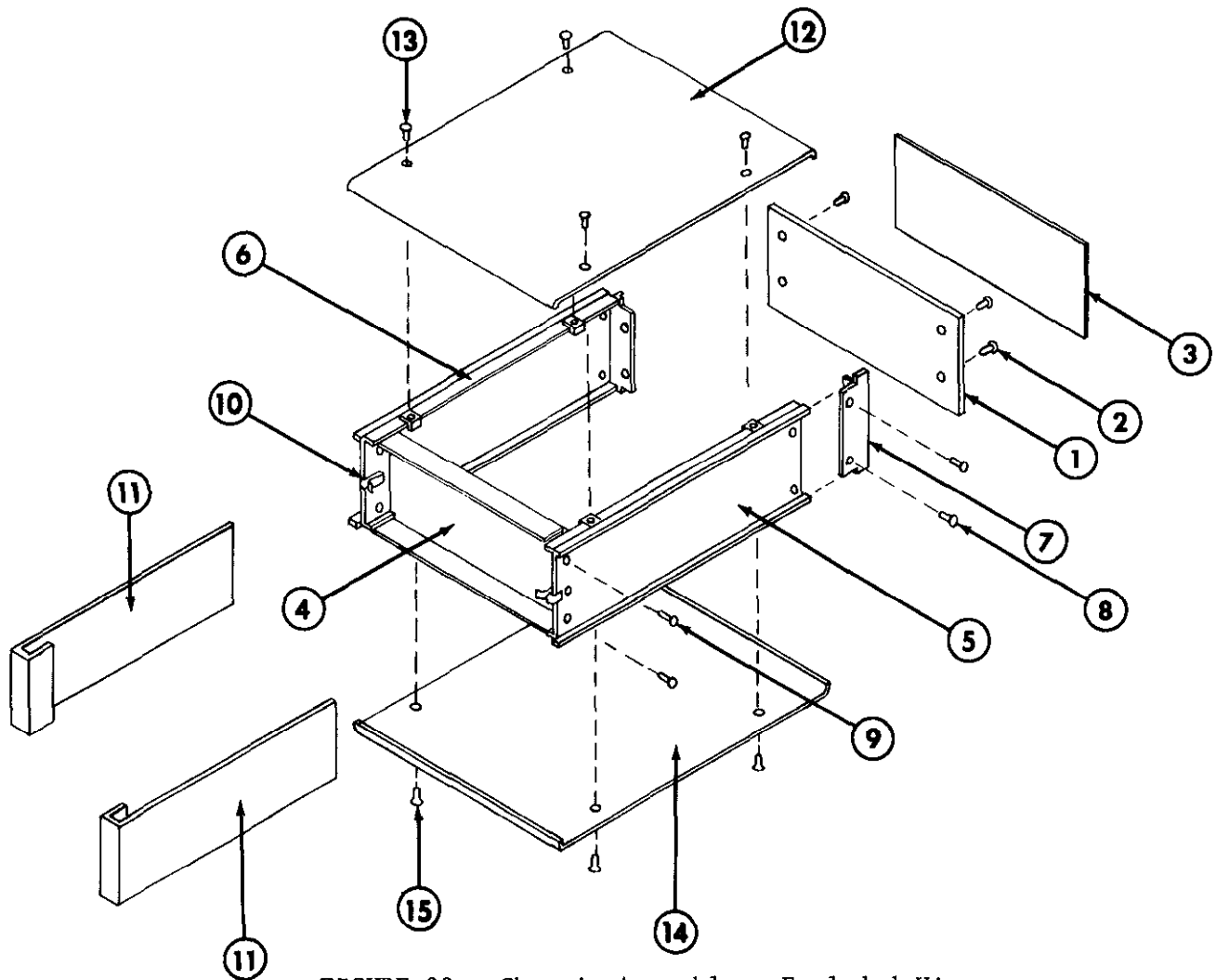

FIGURE 32. Chassis Assembly - Exploded View.

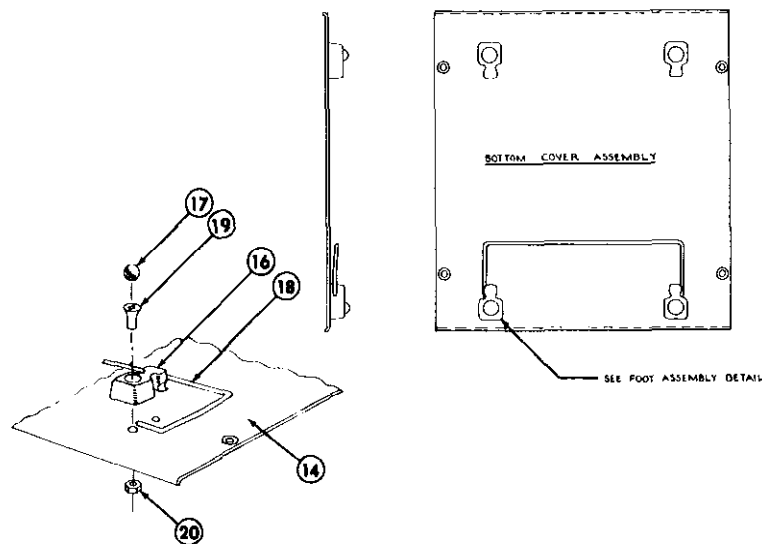

FIGURE 33. Bottom Cover Assembly.

COMPONENT DESIGNATION LISTING
Parts Shown on Schematic No. 25764E

Circuit Desig.	Description	Keithley Part No.	Location
C101	Capacitor, 5 pF, 200V, Poly	C31-5P	Range Switch
C102	Capacitor, 10 pF, 500V, Poly	C138-10P	Range Switch
C103	Capacitor, 22 pF, 500V, Poly	C138-22P	Range Switch
C104	Capacitor, 47 pF, 500V, Poly	C138-47P	Range Switch
C105	Capacitor, 100 pF, 630V, Poly	C252-100P	Range Switch
C106	Capacitor, 100 pF, 630V, Poly	C252-100P	Range Switch
C107	Capacitor, 100 pF, 630V, Poly	C252-100P	Range Switch
C108	Capacitor, 0.1 μ F, 200V, Poly	C251-.1M	Range Switch
C109	Capacitor, 0.01 μ F, 630V, Poly	C252-.01M	Range Switch
C110	Capacitor, 0.001 μ F, 630V, Poly	C252-.001M	Range Switch
C111	Capacitor, 100 pF, 630V, Poly	C252-100P	Range Switch
C112	Capacitor, 270 μ F, 6V, ETT	C194-270M	PC-321
C113	See page 46	...	PC-361
C114	Capacitor, 0.02 μ F, 1000V, CerD	C22-.02M	PC-321
C115	Capacitor, 10 pF, 1000V, CerD	C64-10P	Range Switch
D101	Diode	RF-28	PC-321
D102	Diode	RF-28	PC-321
D103	Diode	RF-28	PC-321
D104	Diode	RF-14	PC-321
J101	Connector, Card-Edge, 15-pin (Mates with PC-323)	CS-259	PC-321
J102	Connector, Card-Edge, 15-pin (Mates with PC-323)	CS-259	PC-321
J103	Connector, Card-Edge, 22-pin (Mates with PC-324)	CS-241	PC-321
J104	Connector, Card-Edge, 6-pin (Mates with PC-325)	CS-267	PC-321
J105	(Shown on Schematic no. 25778E)
J106	(Shown on Schematic no. 25778E)
J107	(Shown on Schematic no. 25778E)
J108	(Shown on Schematic no. 25778E)
J109	Connector, 5-pin	CS-251	PC-321
J110	(Shown on Schematic no. 25778E)
J111	Connector, 3-pin	CS-270	Front Panel
J112	Connector, 10-pin	CS-237	Front Panel
J113	Used on Model 6162
J114	Used on Model 6162
J115	Used on Model 6162
J116	Connector, 10-pin	CS-237	Front Panel
J117	(Shown on Schematic no. 25776D)
J118	Binding Post, White (X1)	BP-11	Rear Panel
J119	Binding Post, Blue (GUARD)	BP-11	Rear Panel
J120	Connector, Triaxial (INPUT)	CS-181	Front Panel
J121	Connector, Binding Post, Black (LO)	BP-11BLK	Rear Panel
J122	Connector, Binding Post, Black (LO)	BP-11BLK	Rear Panel
J123	Connector, Binding Post, Green (GND)	BP-11GRN	Rear Panel
K101	Relay (Zero Check)	SOL-7,RL-45	Chassis
P101	Connector, Card-Edge (PC-323)	...	PC-323
P102	Connector, Card-Edge (PC-323)	...	PC-323
P103	Connector, Card-Edge (PC-324)	...	PC-324
P104	See page 46	...	PC-361
P105	Connector, Male (10 pins)	CS-340-10-X	PC-321
P106	Connector, Male (10 pins)	CS-340-10-X	PC-321
P107	Connector, Male (10 pins)	CS-340-10-X	PC-321
P108	Connector, Male (10 pins)	CS-340-10-X	PC-321
P109	Connector, Male (5 pins)	CS-340-5-X	PC-321
P110	Connector, Male (5 pins)	CS-340-5-X	PC-321
P111	Connector, Male (3 pins)	CS-340-3-X	PC-321
P112	Connector, Male (10 pins)	CS-340-10-X	PC-321
P113	Connector, Male (5 pins)	CS-340-5-X	PC-321
P114	(Shown on schematic no. 25778E)
P115	Connector, Male (10 pins)	CS-340-10-X	PC-321
P116	Connector, Male (10 pins)	CS-340-10-X	PC-321

COMPONENT DESIGNATION LISTING
Parts Shown on Schematic No. 25764E

Circuit Desig.	Description	Part No.	Location
Q101	See page 44		
Q102	See page 44		
Q103	See page 44		
Q104	See page 44		
Q105	Transistor, NPN	TG-103	PC-321
Q106	Transistor, PNP	TG-102	PC-321
Q107	See page 44		
QA101	See page 44		
R101	Resistor, 9.99 Ω , 0.1%, 10W, WW	R221-9.99	Range Switch S101
R102	Resistor, 100 Ω , 0.1%, 10W, WW	R221-100	Range Switch S101
R103	Resistor, 1K Ω , 0.1%, 1/2W, MtF	R169-1K	Range Switch S101
R104	Resistor, 10K Ω , 0.1%, 1/2W, MtF	R169-10K	Range Switch S101
R105	Resistor, 100K Ω , 0.1%, 1/2W, MtF	R169-100K	Range Switch S101
R106	Resistor, 100K Ω , 0.1%, 1/2W, MtF	R169-100K	Range Switch S101
R107	Resistor, 10M Ω , 0.1%, 1/2W	R174-10M	Range Switch S101
R108	Resistor, 10 ⁸ Ω , 1%, 2W, DCb	R14-100M	Range Switch S101
R109	Resistor, 10 ⁹ Ω , +3%, -.5%, Megox	R222-10 ⁹	Range Switch S101
R110	Resistor, 10 ¹⁰ Ω , +3%, -.5%, Megox	R222-10 ¹⁰	Range Switch S101
R111	Resistor, 10 ¹¹ Ω , +3%, -.5%, Megox	R222-10 ¹¹	Range Switch S101
R112	Resistor, 10 ⁸ Ω , 5%, 1/2W	R180-10 ⁸	Range Switch S101
R113	Resistor, 200 Ω , 1%, 1/8W, MtF	R88-200	PC-321
R114	Resistor, Potentiometer, 2K Ω , 0.6W	RP94	PC-321
R115	Resistor, 10K Ω , 0.1%, 1/8W, MtF	R168-10K	PC-321
R116	Resistor, 10 Ω , 1%, 1/8W, MtF	R88-10	PC-321
R117	Resistor, 900 Ω , 0.1%, 1/8W, MtF	R168-900	PC-321
R118	Resistor, 100 Ω , 0.1%, 1/8W, MtF	R168-100	PC-321
R119	Resistor, Potentiometer, 1K Ω , (ZERO)	RP100-1K	Front Panel
R120	See page 44		
R121	See page 44		
R122	See page 44		
R123	See page 44		
R124	See page 44		
R125	Resistor, 10K Ω , 1%, 1/8W, MtF	R88-10K	PC-321
R126	Resistor, 4.02K Ω , 1%, 1/8W, MtF	R88-4.02K	PC-321
R127	Resistor, 4.02K Ω , 1%, 1/8W, MtF	R88-4.02K	PC-321
R128	Resistor, 39.2K Ω , 1%, 1/8W, MtF	R88-39.2K	PC-321
R129	Resistor, 20K Ω , 1%, 1/8W, MtF	R88-20K	PC-321
R130	Resistor, 20K Ω , 1%, 1/8W, MtF	R88-20K	PC-321
S101	Switch, Rotary (RANGE)	SW-368	Front Panel
S102	Switch, Toggle (ZERO CHECK)	SW-309	Front Panel
S103	Switch, Toggle (FAST/NORMAL)	SW-366	Front Panel

COMPONENT DESIGNATION LISTING
Parts Shown on Schematic No. 25777D

Circuit Desig.	Description	Keithley Part No.	Location
C201	Capacitor, 4.7 μ F, 350V, EAL	C240-4.7M	PC-321
C202	Capacitor, 10 μ F, 350V, EAL	C240-10M	PC-321
C203	Capacitor, 4.7 μ F, 350V, EAL	C240-4.7M	PC-321
C204	Capacitor, 10 μ F, 350V, EAL	C240-10M	PC-321
C205	Capacitor, 200 μ F, 35V, EAL	C177-200M	PC-321
C206	Capacitor, 39 μ F, 15V, Epoxy	C228-39M	PC-321
C207	Capacitor, 200 μ F, 35V, EAL	C177-200M	PC-321
C208	Capacitor, 100 pF,	C64-100P	PC-321
C209	Capacitor, 39 μ F, 15V, Epoxy	C228-39M	PC-321
C210	Capacitor, 2000 μ F, 15V, EAL	C210-2000M	PC-321
C211	Capacitor, 2000 μ F, 15V, EAL	C210-2000M	PC-321
C212	Capacitor, 100 pF, 1000V, CerD	C64-100P	PC-321
C213	Capacitor, 400 μ F, 35V, EAL	C212-400M	PC-321
C214	Capacitor, 10 μ F, 20V, ETT	C179-10M	PC-321
C215	Capacitor, 39 μ F, 15V, Epoxy	C228-39M	PC-321
C216	Capacitor, 39 μ F, 15V, Epoxy	C228-39M	PC-321
C217	Capacitor, 39 μ F, 15V, Epoxy	C228-39M	PC-321
C218	Capacitor, 39 μ F, 15V, Epoxy	C228-39M	PC-321
C219	Capacitor, 39 μ F, 15V, Epoxy	C228-39M	PC-321
C220	Capacitor, 0.01 μ F, 1000V, CerD	C22-.01M	PC-321
C221	Capacitor, 0.01 μ F, 1000V, CerD	C22-.01M	PC-321
C222	Capacitor, 0.01 μ F, 1000V, CerD	C22-.01M	PC-321
C223	Capacitor, 0.01 μ F, 1000V, CerD	C22-.01M	PC-321
C224	Capacitor, 4.7 μ F, 20V, ETT	C179-4.7M	PC-321
D201	Diode	RF-38	PC-321
D202	Diode	RF-38	PC-321
D203	Diode	RF-38	PC-321
D204	Diode	RF-38	PC-321
D205	Diode, Full-wave bridge	RF-36	PC-321
D206	Diode, Zener	DZ-7	PC-321
D207	Diode	RF-34	PC-321
D208	Diode	RF-34	PC-321
D209	Diode	RF-38	PC-321
D210	Diode	RF-38	PC-321
F201	Fuse (117V) 3/16A, 3AG SLO-BLO	FU-29	Rear Panel
	Fuse (234V) 1/10A, 3AG SLO-BLO	FU-40	Rear Panel
P201	Connector, Receptacle (Line Power)	CS-254	Rear Panel
Q201	Transistor, PNP, Flat Package	TG-100	PC-321
QA201	Integrated Circuit, Voltage Regulator	IC-25	PC-321
QA202	Integrated Circuit, Voltage Regulator	IC-25	PC-321
QA203	Integrated Circuit, Voltage Regulator	IC-34	PC-321
R201	Resistor, 1.21K Ω , 1%, 1/2W, MtF	R94-1.21K	PC-321
R202	Resistor, 3.01K Ω , 1%, 1/8W, MtF	R88-3.01K	PC-321
R203	Resistor, 22 Ω , 10%, 1/4W, Comp	R76-22	PC-321
R204	Resistor, 4.99K Ω , 0.1%, 1/8W	R176-4.99K	PC-321
R205	Resistor, 7.4K Ω , 0.1%, 1/8W	R176-7.4K	PC-321
R206	Resistor, 6.98K Ω , 1%, 1/8W, MtF	R88-6.98K	PC-321
R207	Resistor, 3.01K Ω , 1%, 1/8W, MtF	R88-3.01K	PC-321
R208	Resistor, 3.01K Ω , 1%, 1/8W, MtF	R88-3.01K	PC-321
R209	Resistor, 1.5K Ω , 10%, 1/4W, Comp	R76-1.5K	PC-321
R210	Resistor, 3.01K Ω , 1%, 1/8W, MtF	R88-3.01K	PC-321
R211	Resistor, 1M Ω , 10%, 1/4W, Comp	R76-1M	PC-321
R212	Resistor, 1M Ω , 10%, 1/4W, Comp	R76-1M	PC-321

COMPONENT DESIGNATION LISTING
 Parts Shown on Schematic No. 25777D

Circuit Desig.	Description	Keithley Part No.	Location
S201	Switch (117 - 234V)	SW-151	Rear Panel
S202	Switch, Toggle (Power ON)	SW-236	Front Panel
T201	Transformer	TR-152	PC-321
P108	Connector, Male (10 pins)	24249A	PC-321
P109	Connector, Male (4 pins)	24249A	PC-321
P110	Connector, Male (5 pins)	24249A	PC-321
P112	Connector, Male (10 pins)	24249A	PC-321
P114	Connector, Male (10 pins)	24249A	PC-321
J101	Connector, Card-Edge, 15-pin (Mates with PC-323)	CS-259	PC-321
J102	Connector, Card-Edge, 15-pin (Mates with PC-323)	CS-259	PC-321
J103	Connector, Card-Edge, 22-pin (Mates with PC-324)	CS-241	PC-321
J104	Connector, Card-Edge, 6-pin (Mates with PC-325)	CS-267	PC-321

COMPONENT DESIGNATION LISTING
Parts Shown on Schematic No. 25776D

Circuit Desig.	Description	Keithley Part No.	Location
C301	Capacitor, 330 pF, 1000V, CerD	C64-330P	PC-324
C302	Capacitor, 39 μ F, 15V, Epoxy	C228-39M	PC-324
C303	Capacitor, 39 μ F, 15V, Epoxy	C228-39M	PC-324
C304	Capacitor, .0033 μ F, 500V, CerD	C22-.0033M	PC-324
C305	Capacitor, 1 μ F, 100V, My	C245-1M	PC-324
C306	Capacitor, .0033 μ F, 500V, CerD	C22-.0033M	PC-324
C207	Capacitor, 39 μ F, 15V, Epoxy	C228-39M	PC-324
C308	Capacitor, 0.1 μ F, 250V, MtF	C178-.1M	PC-324
C309	Capacitor, 0.33 μ F, 50V, CerT	C237-.33M	PC-324
C310	Capacitor, 0.01 μ F, 50V, MPC	C201-.01M	PC-324
C311	Capacitor, 0.01 μ F, 50V, MPC	C201-.01M	PC-324
D301	Diode, Rectifier	RF-28	PC-324
D302	Diode, Rectifier	RF-28	PC-324
D303	Diode, Rectifier	RF-28	PC-324
D304	Diode, Zener, 9V	DZ-41	PC-324
DN301	Diode Network, 8-pin DIP	DN-2	PC-324
Q301	Transistor, Dual N-Channel J-FET, Case TO-71	TG-98	PC-324
Q302	Transistor, N-Channel, J-FET, Case TO-18	TG-97	PC-324
Q303	Transistor, N-Channel, J-FET, Case TO-18	TG-97	PC-324
Q304	Transistor, N-Channel, J-FET, Case TO-18	TG-97	PC-324
Q305	Transistor, N-Channel, J-FET, Case TO-18	TG-97	PC-324
Q306	Transistor, PNP, Case TO-92	TG-61	PC-324
Q307	Transistor, PNP, Case TO-106	TG-110	PC-324
QA301	Integrated Circuit, Amplifier, 8-pin DIP	IC-74	PC-324
QA302	Integrated Circuit, Amplifier, 8-pin DIP	IC-76	PC-324
QA303	Integrated Circuit, Amplifier, 8-pin DIP	IC-76	PC-324
QA304	Integrated Circuit, Amplifier, 8-pin DIP	IC-77	PC-324
QA305	Integrated Circuit, Amplifier, 8-pin DIP	IC-24	PC-324
QA306	Integrated Circuit, Transistor Array	IC-53	PC-324
R301	Resistor, 61.9K Ω , 0.1%, 1/8W, MtF	R168-61.9K	PC-324
R302	Resistor, 61.9K Ω , 0.1%, 1/8W, MtF	R168-1M Ω	PC-324
R303	Resistor, Potentiometer, 1M Ω , .75W	RP89-500K	PC-324
R304	Resistor, Potentiometer, 500 Ω , .75W	RP89-500	PC-324
R305	Resistor, Potentiometer, 500 Ω , .75W	RP89-500	PC-324
R306	Resistor, 1K Ω , 1%, 1/8W, MtF	R88-1K	PC-324
R307	Resistor, Potentiometer, 1K Ω , .75W	RP89-1K	PC-324
R308	Resistor, Potentiometer, 10K Ω , .75W	RP89-10K	PC-324
R309	Resistor, Potentiometer, 1K Ω , .75W	RP89-1K	PC-324
R310	Resistor, 2K Ω , 1%, 1/8W, MtF	R88-2K	PC-324
R311	Resistor, Potentiometer, 2K Ω	RP89-2K	PC-324
R312	Resistor, 10K Ω , 10%, 1/4W, Comp	R76-10K	PC-324
R313	Resistor, 80.6K Ω , 1%, 1/8W, MtF	R88-80.6K	PC-324
RN301	Resistor Network, Thick-Film (Revised)	TF-15*	PC-324
RN302	Resistor Network, Thick-Film	TF-5	PC-324
RN303	Resistor Network, Thick-Film, 16-pin DIP	TF-2	PC-324
RN304	Resistor Network, Thick-Film, 14-pin DIP	TF-3	PC-324
* Revised, RN-301-B Changed to 49.6M Ω			
P103	Connector, Card-Edge (PC-324)		PC-324
P112	Connector, Male (10-pins)	24249A	PC-321
J103	Connector, Card-Edge, 22-pin (Mates with PC-324)	CS-241	PC-321
J117	Connector, Binding Post, Red (1V)	BP-11R	Rear Panel

COMPONENT DESIGNATION LISTING
Parts Shown on Schematic No. 25778E

Circuit Desig.	Description	Keithley Part No.	Location
C401	Capacitor, 0.01 μ F, 500V, CerD	C22-.01M	PC-323
C402	Capacitor, 0.01 μ F, 50V, MPCb	C201-.01M	PC-323
C403	Capacitor, 4.7 μ F, 20V, ETT	C179-4.7M	PC-322
C404	Capacitor, 4700 pF, 500 V, CerD	C-22-4700P	PC-323
D401	Diode, Rectifier	RF-28	PC-323
D402	Diode, Rectifier	RF-28	PC-323
D403	Diode, Rectifier	RF-28	PC-323
D404	Diode, Rectifier	RF-28	PC-323
D405	Diode, Rectifier	RF-28	PC-323
D406	Diode, Rectifier	RF-28	PC-323
DN401	Digital Display (OVERRANGE)	DD-15	PC-322
DN402	Digital Display (Seven-segment)	DD-14	PC-322
DN403	Digital Display (Seven-segment)	DD-14	PC-322
DN404	Digital Display (Seven-segment)	DD-14	PC-322
DN405	Digital Display (Seven-segment)	DD-14	PC-322
DN406	Digital Display (Seven-segment)	DD-14	PC-322
J101	Connector, Card-Edge, 15-pin (Mates with PC-323)	CS-259	PC-321
J102	Connector, Card-Edge, 15-pin	CS-259	PC-321
J103	Connector, Card-Edge, 22-pin	CS-241	PC-321
J105	Connector, 10-pin	CS-237	Display Cable
J106	Connector, 10-pin	CS-237	Display Cable
J107	Connector, 10-pin	CS-237	Display Cable
J108	Connector, 10-pin	CS-237	Display Cable
J110	Connector, 5-pin	CS-251	S401
J115	Connector, (Used on Model 6162)		
P101	Connector, Card-Edge (PC-323)		PC-321
P102	Connector, Card-Edge (PC-323)		PC-321
P105	Connector, Male (10 pins)	24249A	PC-322
P106	Connector, Male (10 pins)	24249A	PC-322
P107	Connector, Male (10 pins)	24249A	PC-321
P108	Connector, Male (10 pins)	24249A	PC-321
P110	Connector, Male (5 pins)	24249A	PC-321
P112	Connector, Male (10 pins)	24249A	PC-321
P113	Connector, Male (5 pins)	24249A	PC-321
P114	Connector, Male (10 pins)	24249A	PC-321
Q401	Transistor, NPN, Case TO-92	TG-62	PC-321
Q402	Transistor, NPN, Case TO-104	TG-68	PC-323
Q403	Transistor, NPN, Case TO-104	TG-68	PC-323
Q404	Transistor, PNP, Case TO-92	TG-90	PC-323
Q405	Transistor, PNP, Case TO-92	TG-90	PC-323
Q406	Transistor, PNP, Case TO-92	TG-90	PC-323
Q407	Transistor, PNP, Case TO-92	TG-90	PC-323
Q408	Transistor, PNP, Case TO-106	TG-66	PC-323
Q409	Transistor, PNP, Case TO-106	TG-66	PC-323
Q410	Transistor, PNP, Case TO-106	TG-66	PC-323
Q411	Transistor, PNP, Case TO-106	TG-66	PC-323
Q412	Transistor, PNP, Case TO-106	TG-110	PC-323
QA401	Integrated Circuit, Hex Inverter, 14-pin DIP	IC-62	PC-323
QA402	Integrated Circuit, Quad 2-Input, NOR 14-pin DIP	IC-69	PC-323
QA403	Integrated Circuit, Quad NAND, 14-pin DIP	IC-22	PC-323
QA404	Integrated Circuit, Hex Inverters, 14-pin DIP	IC-45	PC-323
QA405	Integrated Circuit, Hex Inverters, 14-pin DIP	IC-45	PC-323
QA406	Integrated Circuit, Timing Logic, 8-pin DIP	IC-71	PC-323
QA407	Integrated Circuit, Triple 3-Input NAND, 14-pin DIP	IC-68	PC-323
QA408	Integrated Circuit, LSI, 28-pin DIP	LSI-2	PC-323
QA409	Integrated Circuit, Hex Inverter, 14-pin DIP	IC-62	PC-323

COMPONENT DESIGNATION LISTING
Parts Shown on Schematic No. 25778E

Circuit Desig.	Description	Keithley Part No.	Location
R401	Resistor, 1.1K Ω , 10%, 1/4W, Comp	R76-1.1K	PC-322
R402	Resistor, 845 Ω , 10%, 1/4W, Comp	R88-845	PC-321
R403	Resistor, 715 Ω , 1%, 1/8W, MtF	R88-715	PC-323
R404	Resistor, 715 Ω , 1%, 1/8W, MtF	R88-715	PC-323
R405	Resistor, 402 Ω , 10%, 1/4W, Comp	R88-402	PC-321
R406	Resistor, 402 Ω , 10%, 1/4W, Comp	R88-402	PC-321
R407	Resistor, 402 Ω , 10%, 1/4W, Comp	R88-402	PC-321
R408	Resistor, 402 Ω , 10%, 1/4W, Comp	R88-402	PC-321
R409	Resistor, 12.4K Ω , 1%, 1/8W, MtF	R88-12.4K	PC-323
R410	Resistor, 715 Ω , 1%, 1/8W, MtF	R88-715	PC-323
R411	Resistor, 3.01K Ω , 1%, 1/8W, MtF	R88-3.01K	PC-323
R412	Resistor, 1.1K Ω , 1%, 1/8W, MtF	R88-1.1K	PC-323
R413	Resistor, 6.04K Ω , 1%, 1/8W, MtF	R88-6.04K	PC-323
R414	Resistor, 20K Ω , 1%, 1/8W, MtF	R88-20K	PC-321
R415	Resistor, 20K Ω , 1%, 1/8W, MtF	R88-20K	PC-321
R416	Resistor, 20K Ω , 1%, 1/8W, MtF	R88-20K	PC-321
R417	Resistor, 20K Ω , 1%, 1/8W, MtF	R88-20K	PC-321
R418	Resistor, 2.2K Ω , 10%, 1/4W, Comp	R76-2.2K	PC-321
RN401	Resistor Network, Thick-Film, 16-pin DIP	TF-41	PC-322
RN402	Resistor Network, Thick-Film, 14-pin DIP	TF-16	PC-323
RN403	Resistor Network, Thick-Film, 14-pin DIP	TF-18	PC-323
RN404	Resistor Network, Thick-Film, 14-pin DIP	TF-19	PC-323
RN405	Resistor Network, Thick-Film, 14-pin DIP	TF-40	PC-323
S401	Switch, Rotary (SENSITIVITY)	SW-367	Front Panel

COMPONENT DESIGNATION LISTING
Parts Shown on Schematic No. 25764E

Circuit Desig.	Description	Keithley Part No.	Location
C113	Capacitor, 0.001 μ F, 1000V, CerD	C64-.001M	PC-361
P104	Card Edge, PC-361	PC-361	PC-361
Q101	Transistor, FET, Case TO-18, Selected TG-51	26612A	PC-361
Q107	Transistor, FET, Case TO-18, Selected TG-51	Matched Pair	PC-361
Q102A,B	Transistor, Dual NPN	TG-91	PC-361
Q103	Transistor, NPN, Case TO-106	TG-39	PC-361
Q104	Transistor, NPN, Case TO-106	TG-39	PC-361
Q101	Integrated Circuit, 8-pin DIP	IC-74	PC-361
R120	Resistor, 75k Ω , 0.1%, 0.3W	R212-75K	PC-361
R121	Resistor, 75k Ω , 0.1%, 0.3W	R212-75K	PC-361
R122	Resistor, 100 Ω , 0.1%, 1/8W, MtF	R168-100	PC-361
R123	Resistor, 200 Ω , 0.75W, Cermet	RP89-200	PC-361
R124	Resistor, 100k Ω , 10%, 1/4W, Comp	R76-100K	PC-361

COMPONENT DESIGNATION LISTING
Parts Shown on Schematic 25715D

Circuit Desig.	Description	Mfr. Code	Mfr. Desig.	Keithley Part No.
C101	Capacitor, 4 μ F, 100V, My	14752	230B1B505	C245-4M
D101	Diode	ITT	1N87	RF-39
D102	Diode	ITT	1N87	RF-39
D103	Diode	ITT	1N87	RF-39
D104	Diode	ITT	1N87	RF-39
D105	Diode	ITT	1N87	RF-39
D106	Diode	ITT	1N87	RF-39
D107	Diode	ITT	1N87	RF-39
Q101	Transistor, PNP, Case TO-106	FAIR	2N5139	TG-66
Q102	Transistor NPN, Case TO-92	MOT	2N5089	TG-62
Q103	Transistor NPN, Case TO-104	RCA	2N5183	TG-68
QA101	Integrated Circuit, Isolator, 6-pin DIP	07263	FCD820	IC-82
QA102	Integrated Circuit, Isolator, 6-pin DIP	07263	FCD820	IC-82
QA103	Integrated Circuit, Isolator, 6-pin DIP	07263	FCD820	IC-82
QA104	Integrated Circuit, Isolator, 6-pin DIP	07263	FCD820	IC-82
QA105	Integrated Circuit, Isolator, 6-pin DIP	07263	FCD820	IC-82
QA106	Integrated Circuit, Isolator, 6-pin DIP	07263	FCD820	IC-82
QA107	Integrated Circuit, Isolator, 6-pin DIP	07263	FCD820	IC-82
QA108	Integrated Circuit, Isolator, 6-pin DIP	07263	FCD820	IC-82
QA109	Integrated Circuit, Flip-Flop, TTL, 14-pin DIP	01295	SN74L74N	IC-87
QA110	Integrated Circuit, Flip-Flop, TTL, 14-pin DIP	01295	SN74L74N	IC-87
QA111	Integrated Circuit, Quad NAND, 14-pin DIP	04713	MC858P	IC-52
QA112	Integrated Circuit, Hex Inverter, 14-pin DIP	04713	MC836P	IC-80
QA113	Integrated Circuit, Hex Inverter, 14-pin DIP	04713	MC836P	IC-80
QA114	Integrated Circuit, Hex Inverter, 14-pin DIP	04713	MC836P	IC-80
R101	Resistor, 3.3K Ω , 10%, 1/4W, Comp	A-B	CB-332-10%	R76-3.3K
R102	Resistor, 1K Ω , 10%, 1/4W, Comp	A-B	CB-102-10%	R76-1K
R103	Resistor, 4.7K Ω , 10%, 1/4W, Comp	A-B	CB-472-10%	R76-4.7K
R104	Not Used			
R105	Not Used			
R106	Not Used			
R107	Resistor, 330 Ω , 10%, 1/4W, Comp	01121	CB-331-10%	R76-330
R108	Resistor, 10K Ω , 10%, 1/4W, Comp	01121	CB-103-10%	R76-10K
R109	Resistor, 330 Ω , 10%, 1/4W, Comp	01121	CB-331-10%	R76-330
R110	Resistor, 330 Ω , 10%, 1/4W, Comp	01121	CB-331-10%	R76-330
R111	Resistor, 330 Ω , 10%, 1/4W, Comp	01121	CB-331-10%	R76-330
R112	Resistor, 330 Ω , 10%, 1/4W, Comp	01121	CB-331-10%	R76-330
R113	Resistor, 330 Ω , 10%, 1/4W, Comp	01121	CB-331-10%	R76-330
R114	Resistor, 330 Ω , 10%, 1/4W, Comp	01121	CB-331-10%	R76-330
R115	Resistor, 2.5M Ω , 10%, 1/4W, Comp Variable			RP101-2.5M
R116	Resistor, 10K Ω , 1%, 1/8W, MtF	IRC	CEA-TO-10K	R88-10K
RN101	Resistor Network, Thick-Film, 14-pin DIP			TF19-4.7K
P101	Connector, Male (10 pins)			24249A
P102	Connector, Male (5 pins)			24249A
P104	Connector, Male (10 pins)			24249A
P105	Connector, Male (10 pins)			24249A
P108	Connector, Male (10 pins)			24249A

COMPONENT DESIGNATION LISTING
Parts Shown on Schematic No. 25716D

Circuit Desig.	Description	Mfr. Code	Mfr. Desig.	Keithley Part No.
C201	Capacitor, 0.001 μ F, 250V, MtF	AMPX	C280AE	C178-.001M
C202	Capacitor, 0.001 μ F, 250V, MtF	AMPX	C280AE	C178-.001M
C203	Capacitor, 0.001 μ F, 250V, MtF	AMPX	C280AE	C178-.001M
D201	Diode	ITT	1N87	RF-39
D202	Diode	ITT	1N87	RF-39
D203	Diode	ITT	1N87	RF-39
D204	Diode	ITT	1N87	RF-39
D205	Diode	ITT	1N87	RF-39
D206	Diode	ITT	1N87	RF-39
P108	Connector, Male (10 pins)			24249A
Q201	Transistor, NPN, Case TO-92	MOT	2N5089	TG-62
Q202	Transistor, NPN, Case TO-92	MOT	2N5089	TG-62
QA201	Integrated Circuit, BCD Counter, TTL, 14-pin DIP	TEXAS	SN74L90N	IC-84
QA202	Integrated Circuit, BCD Counter, TTL, 14-pin DIP	TEXAS	SN74L90N	IC-84
QA203	Integrated Circuit, BCD Counter, TTL, 14-pin DIP	01295	SN74L90N	IC-84
QA204	Integrated Circuit, Quad Latch, TTL, 16-pin DIP	02763	93L1459X	IC-90
QA205	Integrated Circuit, Quad Latch, TTL, 16-pin DIP	02763	93L1459X	IC-90
QA206	Integrated Circuit, Quad Latch, TTL, 16-pin DIP	02763	93L1459X	IC-90
QA207	Integrated Circuit, Quad Latch, TTL, 16-pin DIP	02763	93L1459X	IC-90
QA208	Integrated Circuit, Monostable, 14-pin DIP	01295	SN74L122N	IC-83
QA209	Integrated Circuit, Monostable, 14-pin DIP	01295	SN74L122N	IC-83
QA210	Integrated Circuit, Monostable, 14-pin DIP	01295	SN74L122N	IC-83
QA211	Integrated Circuit, Dual Flip-Flop, 14-pin DIP	01295	SN74L73N	IC-86
QA212	Integrated Circuit, Dual Flip-Flop, 14-pin DIP	01295	SN74L74N	IC-87
QA213	Not Used			
QA214	Integrated Circuit, Hex Inverter, 14-pin DIP	01295	SN74L04N	IC-85
QA215	Integrated Circuit, Hex Inverter, 14-pin DIP	01295	SN74L04N	IC-85
QA216	Not Used			
QA217	Integrated Circuit, Hex Inverter, 14-pin DIP	04713	MC836P	IC-80
QA218	Not Used			
QA219	Integrated Circuit, Quad NAND gate, 14-pin DIP	04713	MC858P	IC-52
QA220	Integrated Circuit, Quad NAND gate, 14-pin DIP	04713	MC858P	IC-52
QA221	Integrated Circuit, Quad NAND gate, 14-pin DIP	04713	MC858P	IC-52
QA222	Integrated Circuit, Quad NAND gate, 14-pin DIP	04713	MC858P	IC-52
QA223	Integrated Circuit, Dual NAND, 14-pin DIP	04713	MC1800P	IC-89
QA224	Integrated Circuit, Isolator, 6-pin DIP	07263	FCD820	IC-82
QA225	Integrated Circuit, Isolator, 6-pin DIP	07263	FCD820	IC-82
QA226	Integrated Circuit, Isolator, 6-pin DIP	07263	FCD820	IC-82
QA227	Integrated Circuit, Isolator, 6-pin DIP	07263	FCD820	IC-82
QA228	Integrated Circuit, Isolator, 6-pin DIP	07263	FCD820	IC-82
QA229	Integrated Circuit, Isolator, 6-pin DIP	07263	FCD820	IC-82
R201	Resistor, 330 Ω , 10%, 1/4W, Comp	01121	CB-331-10%	R76-330
R202	Resistor, 330 Ω , 10%, 1/4W, Comp	01121	CB-331-10%	R76-330
R203	Resistor, 330 Ω , 10%, 1/4W, Comp	01121	CB-331-10%	R76-330
R204	Resistor, 330 Ω , 10%, 1/4W, Comp	01121	CB-331-10%	R76-330
R205	Resistor, 330 Ω , 10%, 1/4W, Comp	01121	CB-331-10%	R76-330
R206	Resistor, 330 Ω , 10%, 1/4W, Comp	01121	CB-331-10%	R76-330
R207	Resistor, 1K Ω , 10%, 1/4W, Comp	01121	CB-102-10%	R76-1K
R208	Resistor, 1K Ω , 10%, 1/4W, Comp	01121	CB-102-10%	R76-1K
R209	Resistor, 10K Ω , 10%, 1/4W, Comp	01121	CB-103-10%	R76-10K
R210	Resistor, 10K Ω , 10%, 1/4W, Comp	01121	CB-103-10%	R76-10K
R211	Resistor, 10K Ω , 10%, 1/4W, Comp	01121	CB-103-10%	R76-10K
R212	Resistor, 10K Ω , 10%, 1/4W, Comp	01121	CB-103-10%	R76-10K
R213	Resistor, 10K Ω , 10%, 1/4W, Comp	01121	CB-103-10%	R76-10K
R214	Resistor, 10K Ω , 10%, 1/4W, Comp	01121	CB-103-10%	R76-10K
RN201	Resistor Network			TF19-4.7K

COMPONENT DESIGNATION LISTING
Parts Shown on Schematic No. 25717C

Circuit Desig.	Description	Mfr. Code	Mfr. Desig.	Keithley Part No.
D301	Germanium, 20V, 50 mA	15238	1N3592	RF-39
D302	Germanium, 20V, 50 mA	15238	1N3592	RF-39
D303	Germanium, 20V, 50 mA	15238	1N3592	RF-39
D304	Germanium, 20V, 50 mA	15238	1N3592	RF-39
P103	Connector, Male (10 pins)			24249A
P105	Connector, Male (10 pins)			24249A
P106	Connector, Male (10 pins)			24249A
P107	Connector, Male (10 pins)			24249A
P108	Connector, Male (10 pins)			24249A
QA301	Integrated Circuit, Quad NAND	04713	MC858P	IC-52
QA302	Integrated Circuit, Quad NAND	04713	MC858P	IC-52
QA303	Integrated Circuit, Decoder, 16-pin DIP	01295	SN74L42N	IC-88
QA304	Integrated Circuit, Quad Latch, 16-pin DIP	02763	93L1459X	IC-90
QA305	Not Used	-----		
QA306	Integrated Circuit, Quad NAND	04713	MC858P	IC-52
QA307	Integrated Circuit, Quad NAND	04713	MC858P	IC-52
RN301	Resistor Network			TF19-4.7K

COMPONENT DESIGNATION LISTING
Parts Shown on Schematic No. 25823C

Circuit Desig.	Description	Mfr. Code	Mfr. Desig.	Keithley Part No.
C401	Capacitor, 0.1 μ F, 250V, MtF	73445	C280AE	C178-.1M
C402	Capacitor, 2000 μ F, 15V, EAL	29309	JCN2000158P	C210-2000M
C403	Capacitor, 2000 μ F, 15V, EAL	29309	JCN2000158P	C210-2000M
C404	Capacitor, 39 μ F, 15V, Epoxy	17554	TD401539610	C228-39M
C405	Capacitor, 39 μ F, 15V, Epoxy	17554	TD401539610	C228-39M
C406	Capacitor, 39 μ F, 15V, Epoxy	17554	TD401539610	C228-39M
C407	Capacitor, 39 μ F, 15V, Epoxy	17554	TD401539610	C228-30M
C408	Capacitor, 39 μ F, 15V, Epoxy	17554	TD401539610	C228-39M
C409	Capacitor, 39 μ F, 15V, Epoxy	17554	TD401539610	C228-39M
C410	Capacitor, 39 μ F, 15V, Epoxy	17554	TD401539610	C228-39M
C411	Capacitor, 39 μ F, 15V, Epoxy	17554	TD401539610	C228-39M
C412	Capacitor, 39 μ F, 15V, Epoxy	17554	TD401539610	C228-39M
D401	Diode	13327	1N4139	RF-34
D402	Diode	13327	1N4139	RF-34
DS401	Pilot Lamp, Amber	07294	CF03ACS1869	PL-51
F401	Fuse, Slo-Blo 3AG, 1/8A	71400	MDL	FU-20
P401	Connector, Power Input	82389	EAC301	CS-254
QA401	Integrated Circuit, Regulator	12040	LM309K	IC-34
S401	Switch, Line Voltage (117V-234V)			SW-151
S402	Switch, Power ON			SW-236
T401	Transformer			TR-155
J401	Connector, Binding Post (Green) GROUND	BP-11-GRN
J402	Connector, Binding Post (Black) LO	BP-11-BLK
..	Shorting Link (Used between J401 and J402)			BP-6

TABLE 7-5.
Electrical Parts List

NOTE: The following list of electrical parts is arranged so that all parts are grouped by subassembly such as printed circuit board, switch, front chassis, etc. Component layouts showing physical position of each part is furnished for each printed circuit assembly. The Keithley part number should be used whenever replacement parts are ordered from Keithley Instruments or its representatives.

MAIN CHASSIS - FRONT PANEL

MISCELLANEOUS

Keithley Part No.	Quantity Per Assembly	Description	Mfr. Mfr. Desig.	Circuit Desig.
25579A	1	Knob Assembly (ZERO)	80164 ----	----
RP100-1K	1	Potentiometer (ZERO) 1K Ω	----- ----	R119
SW-236	1	Switch, Toggle (ON)	80164 ----	S202
SW-309	1	Switch, Toggle (ZERO CHECK)	80164 ----	S102
SW-367	1	Switch, Rotary (SENSITIVITY)	80164 ----	S401
25769A	1	Knob Assembly (SENSITIVITY)	80164 ----	----
SW-368	1	Switch, Rotary (RANGE)	80164 ----	S101
25573A	1	Knob Assembly (RANGE)	80164 ----	----
SW-366	1	Switch (FAST/NORMAL)	80164 ----	S103
CS-181	1	Connector, Triaxial (INPUT)	95712 33050-2NT34	J120

RANGE SWITCH

CAPACITORS

Keithley Part No.	Quantity Per Assembly	Description	Mfr. Mfr. Desig.	Circuit Desig.
C31-5P	1	5pF, 200V, Poly	00686 E1013-1	C101
C138-10P	1	10pF, 500V, Poly	71590 CPR-10J	C102
C138-22P	1	22pF, 500V, Poly	71590 CPR-22J	C103
C138-47P	1	47pF, 500V, Poly	71590 CPR-47J	C104
C251-.1M	1	0.1 μ F, 200V, Poly	97419 PYWR-.1 μ F	C108
C252-100P	4	100pF, .630V, Poly	97419 B31360-A1101	C105,106,107,111
C252-.001M	1	.001 μ F, .630V, Poly	97419 B31360-A1102	C110
C252-.01M	1	.01 μ F, .630V, Poly	97419 B31360-A1103	C109
C64-10P	1	10pF, 1000V, CerD	71590 DD-100-10%	C115

RESISTORS

R-229-100M

R14-100M	1	10 ⁸ Ω , 1%, 2W, DCb	91637 DC-2-10 ⁸	R108
R169-1K	1	1K Ω , 0.1%, 1/2W, MtF	91637 MFF-1K	R103
R169-10K	1	10K Ω , 0.1%, 1/2W, MtF	91637 MFF-10K	R104
R169-100K	1	100K Ω , 0.1%, 1/2W, MtF	91637 MFF-100K	R105
R169-1M	1	1M Ω , 0.1%, 1/2W, MtF	91637 MFF-1M	R106
R174-10M	1	10M Ω , 0.1%, 1/2W, MtF	14292 AME-70-10M	R107
R180-10 ⁸	1	10 ⁸ Ω , 5%, 1/2W	07716 GBTY2-10 ⁸	R112
R221-9.99	1	9.99 Ω , 0.1%, 10W, WW	02985 TS-10W-9.99	R101
R221-100	1	100 Ω , 0.1%, 10W, WW	02985 TS-10W-100	R102
R222-10 ⁹	1	10 ⁹ Ω , +3%, -5%, Megox	00327 M51-10 ⁹	R109
R222-10 ¹⁰	1	10 ¹⁰ Ω , +3%, -5%, Megox	00327 M51-10 ¹⁰	R110
R222-10 ¹¹	1	10 ¹¹ Ω , +3%, -5%, Megox	00327 M51-10 ¹¹	R111

MAIN CHASSIS - REAR PANEL

MISCELLANEOUS

Keithley Part No.	Quantity Per Assembly	Description	Mfr. Mfr.	Mfr. Desig.	Circuit Desig.
BP-11W	1	Binding Post, White (X1)	58474	DF21	J121, J122
BP-11R	1	Binding Post, Red (1V)	58474	DF21	J123
BP-11BLK	2	Binding Post, Black (LO)	58474	DF21	
BP-11BLU	1	Binding Post, Blue (GUARD)	58474	DF21	J119
BP-11GRN	1	Binding Post, Green (CASE)	58474	DF21	
BP-6	1	Shorting Link	24655	938-L	
FH-11	1	Fuse Holder	75915	348877	
FU-29	1	Fuse, 3AG, Slo-Blo, 117V, 3/16A	75915	313.187	F201
FU-40	1	Fuse, 3AG, Slo-Blo, 234V, 1/10A	75915	313.100S	F201
SW-151	1	Switch (117 - 234V)	80164		S201
CS-254	1	Receptacle, Line Power	82389	EAC301	P201
CO-7	1	Line Cord	70903		

MOTHER BOARD

PC-321

MISCELLANEOUS

Keithley Part No.	Quantity Per Assembly	Description	Mfr. Mfr.	Mfr. Desig.	Circuit Desig.
CS-236	69	Female Pin	22526	47439	—
CS-340-10	6	Connector, 10-pin	22526	20052	P112,114-116,107-108
CS-241	1	Connector, Card-Edge, 22-pin	71785	2522230240	J103
CS-251	2	Connector, 5-pin	22526	20370	P109
CS-259	2	Connector, Card-Edge, 15-pin	71785	2521530160	J101,102
CS-267	1	Connector, Card-Edge, 6-pin	71785	50-6B-10	J104
24249A	81	Male Pin	80164		
CS-270	1	Connector, 3-pin, Mini-PV	22526	65039-034	J111
DZ-7	1	Diode, Zener	04713	1N935	D206
RP94-2K	1	Potentiometer, 2K Ω , 0.6W	94271	50200S-2K	R114
TR-152	1	Transformer	80164		T101

CAPACITORS

Keithley Part No.	Quantity Per Assembly	Description	Mfr. Mfr.	Mfr. Desig.	Circuit Desig.
C22-.01M	4	0.01 μ F, 1000V, CerD	56289	10SS-S10	C220,221,222,223
C22-.02M	1	0.02 μ F, 1000V, CerD	56289	10SS-S20	C114
C64-100P	2	100pF, 1000V, CerD	71590	DD-101-10%	C208,212
C177-200M	2	200 μ F, 35V, EAL	90201	MTV200N35	C205,207
C179-10M	1	10 μ F, 20V, ETT	17554	TSD220106	C214
C194-270M	1	270 μ F, 6V, ETT	06751	TD5006277-20	C112
C210-2000M	2	2000 μ F, 15V, EAL	29309	JCN2000158P	C210,211
C212-400M	1	400 μ F, 35V, EAL	29309	JC12400358P	C213
C228-39M	7	39 μ F, 15V, Epoxy	17554	TD401533610	C206,209,215,216, 217,218,219
2240-4.7M	2	4.7 μ F, 350V, EAL	24138	PCK4.7UJ350	C201,203
C179-4.7	1	4.7 μ F, 20V, ETT	17554		C224
C240-10	2	10 μ F, 350V, EAL	24138	350VB10	C202, C204

MOTHER BOARD
PC-321

Keithley Part No.	Quantity Per Assembly	Description	Mfr. Mfr.	Desig.	Circuit Desig.
INTEGRATED CIRCUITS					
IC-25	2	Voltage Regulator, 14-pin DIP	07263	UGA7723393	QA201,202
IC-34	1	Voltage Regulator, Case TO-3	12040	LM309K	QA203
RESISTORS					
R76-22	1	22 Ω , 10%, 1/4W, Comp	01121	CB-220	R203
R88-845	1	845 Ω , 1%, 1/8W, MtF	01121	CEA-TO-845	R402
R88-402	4	402 Ω , 1%, 1/8W, MtF	01121	CEA-TO-402	R405, 6, 7, 8
R76-2.2K	1	2.2K Ω , 10%, 1/4W, Comp	01121	CB-222	R418
R76-1M	2	1M Ω , 10%, 1/4W, Comp	01121	CB-105	R211,212
R88-10	1	10 Ω , 1%, 1/8W, MtF	07716	CEA-TO-10 Ω	R116
R88-200	1	200 Ω , 1%, 1/8W, MtF	07716	CEA-TO-200 Ω	R113
R88-3.01K	4	3.01K Ω , 1%, 1/8W, MtF	07716	CEA-TO-3.01K Ω	R202,207,208,210
R88-2.49K	2	2.49K Ω , 1%, 1/8W, MtF	07716	CEA-TO-4.02K Ω	R126,127
R88-6.98K	1	6.98K Ω , 1%, 1/8W, MtF	07716	CEA-TO-6.98K Ω	R206
R88-10K	1	10K Ω , 1%, 1/8W, MtF	07716	CEA-TO-10K Ω	R125
R88-20K	6	20K Ω , 1%, 1/8W, MtF	07716	CEA-TO-20K Ω	R129,130,414,415, 416,417
R88-39.2K	1	39.2K Ω , 1%, 1/8W, MtF	07716	CEA-TO-39.2K Ω	R128
R94-1.21K	1	1.21K Ω , 1%, 1/2W, MtF	07716	CEC-1.21K Ω	R201
R168-100	1	100 Ω , 0.1%, 1/8W, MtF	91637	MFF-1/8-100	R118
R168-900	1	900 Ω , 0.1%, 1/8W, MtF	91637	MFF-1/8-900	R117
R168-10K	1	10K Ω , 0.1%, 1/8W, MtF	91637	MFF-1/8-10K Ω	R115
R176-4.99K	1	4.99K Ω , 0.1%, 1/8W	91637	MMF-1/8-4.99K Ω	R204
R176-7.4K	1	7.4K Ω , 0.1%, 1/8W	91637	MMF-1/8-7.4K Ω	R205
R88-1.5K	1	1.5K, 1%, 1/8W, MtF	00121	CEA-1.5K	R209
DIODES					
RF-14	1	Rectifier, 400mA, 225V	TEXAS	1N645	D104
RF-28	3	Rectifier	01295	1N914	D101,102,103
RF-34	2	Rectifier	13327	1N4139	D207-208
RF-36	1	Four diode, full-wave bridge	83701	PD-10	D205
RF-38	8	Rectifier, 1.0A, 800V	04713	1N4006	D201,202,203,204, 209,210,D105,106
TRANSISTORS					
TG-62	1	NPN, Case TO-92	04713	2N5089	Q401
TG-100	1	PNP, Flat Package	04713	D45C3	Q201
TG-105	2	PNP, Case TO-5	04713	8TP655 2N5416	Q106,Q109
TG-93	2	NPN, Case TO-5	04713	MST656 2N3439	Q105,Q108
R-1-220K	4	220K μ , 10%, 1/2W, Comp			R132,133,135,136
R76-10K	2	10K μ , 10%, 1/4W, Comp			R131
R76-1K	1	1K μ , 10%, 1/4W, Comp			R134

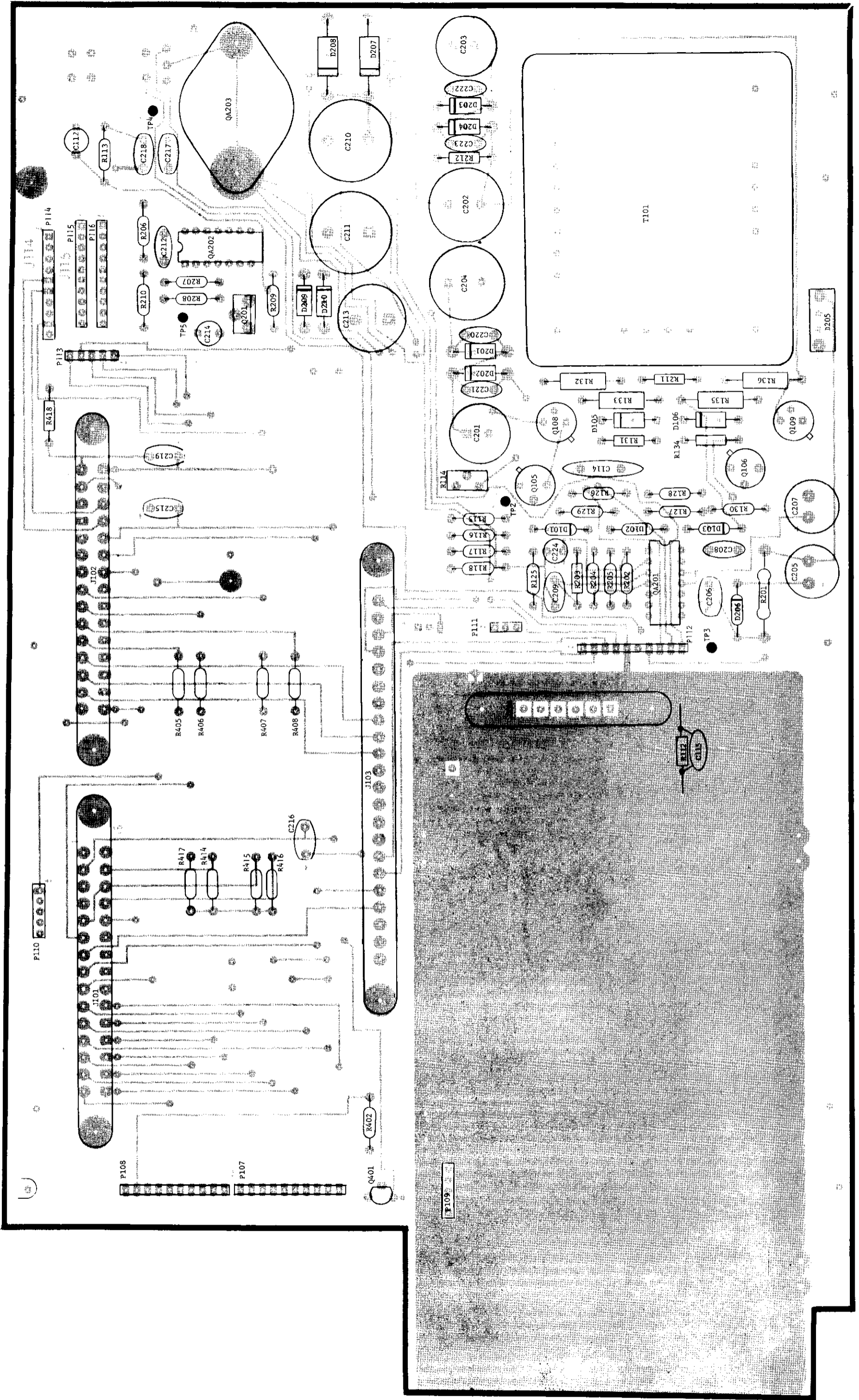

FIGURE 34. COMPONENT LAYOUT, PC-321.

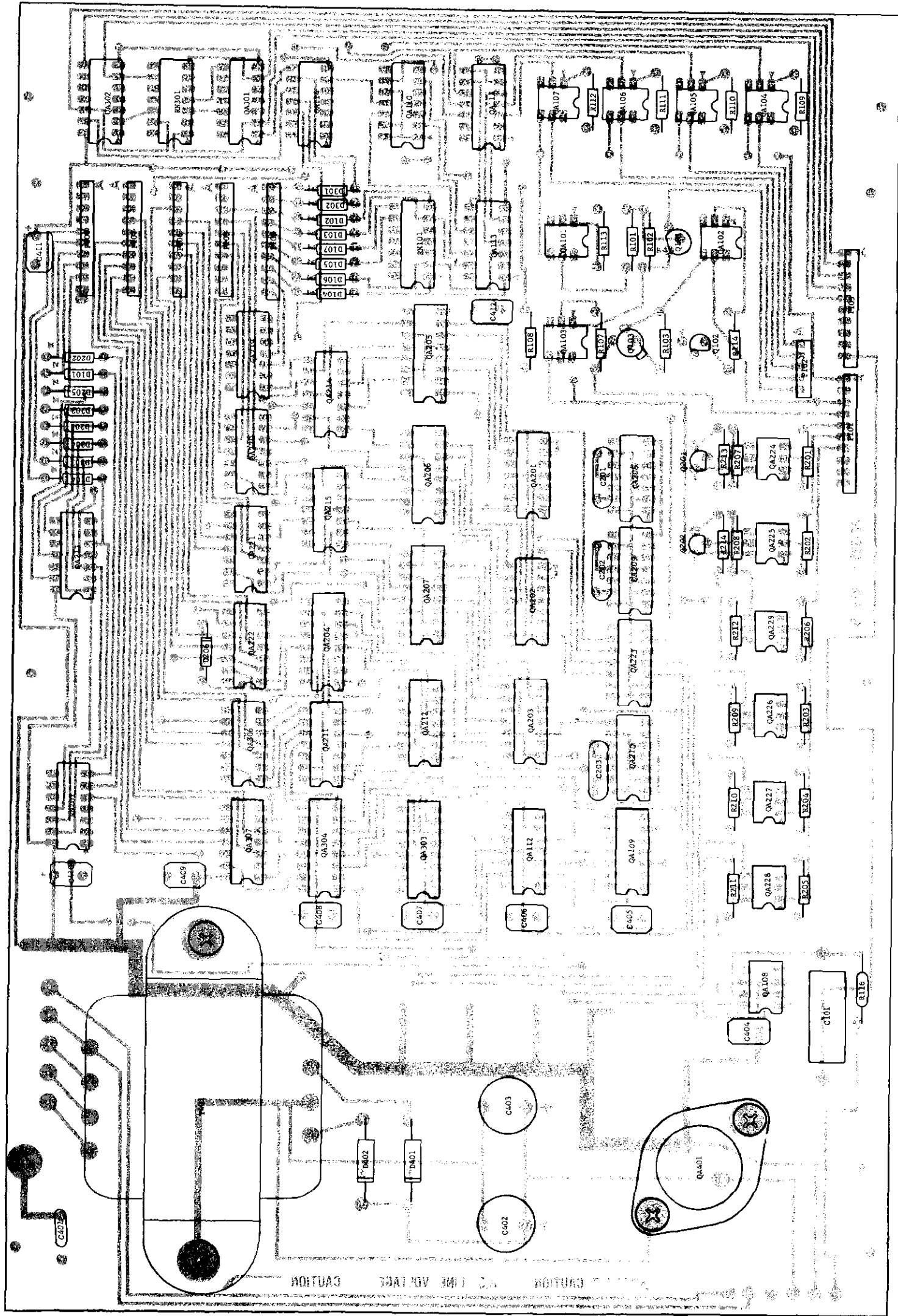

FIGURE 35. Component Layout, PC-335

DISPLAY BOARD

PC-322

MISCELLANEOUS

Keithley Part No.	Quantity Per Assembly	Description	Mfr.	Mfr. Desig.	Circuit Desig.
R-76-1.1K	1	Resistor, 1.1KΩ, 10%, 1/4W, Comp	01121	CB112-10%	R401
TF-41	1	Resistor Network, 16-pin DIP	CTS	Special	RN401
DD-9	5	Digital Display (Seven Segment)*	H-P	5082-7730	DN402,3,4,5,6
DD-11	1	Digital Display (Overrange)*	H-P	5082-7732	DN401

*Light intensity "C", "D", or "E"

CAPACITORS

C22-.01M	1	0.01μF, 500V, CerD	72982	87125U0103M	C401
C201-.01M	1	0.01μF, 50V, MPCB	14752	625B1A	C402

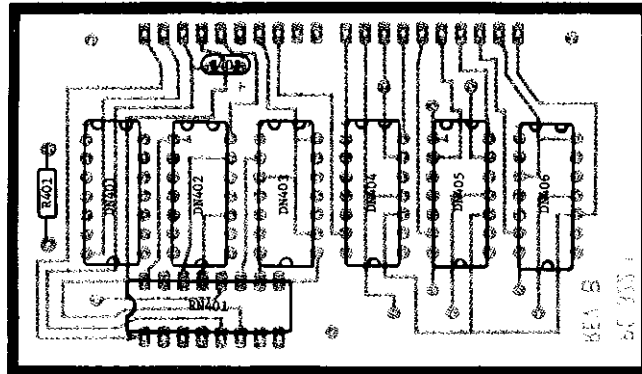

FIGURE 36. Component Layout, PC-322.

LOGIC BOARD
PC-323

INTEGRATED CIRCUITS

Keithley Part No.	Quantity Per Assembly	Description	Mfr.	Mfr. Desig.	Circuit Desig.
IC-22	1	Quad NAND, 14-pin DIP	04713	MC858P	QA403
IC-45	2	Hex Inverters, 14-pin DIP	01295	SN7403N	QA404,405
IC-62	2	Hex Inverter, 14-pin DIP	01295	SN7406	QA401,409
IC-68	1	Triple 3-Input Positive NAND, 14-pin DIP	01295	SN7412N	QA407
IC-69	1	Quad 2-Input Positive NOR, 14-pin DIP	01295	SN74L02N	QA402
IC-71	1	Timing Logic, 8-pin DIP	18324	NE555V	QA406

MISCELLANEOUS

LSI-2	1	Integrated Circuit	80164	-----	QA408
-------	---	--------------------	-------	-------	-------

RESISTORS

R88-715	3	715Ω, 1%, 1/8W, MtF	07716	CEA-715Ω	R410,403,404
R88-1.1K	1	1.1KΩ, 1%, 1/8W, MtF	07716	CEA-1.1KΩ	R412
R88-3.01K	1	3.01KΩ, 1%, 1/8W, MtF	07716	CEA-3.01KΩ	R411
R88-6.04K	1	6.04KΩ, 1%, 1/8W, MtF	07716	CEA-6.04KΩ	R413
R88-12.4K	1	12.4KΩ, 1%, 1/8W, MtF	07716	CEA-12.4KΩ	R409

DIODES

RF-28	5		01295	1N914	D401, 403-406
-------	---	--	-------	-------	---------------

RESISTOR NETWORKS

TF-16	1	Thick Film, 14-pin DIP	73138	1899-151.0	RN402
TF-18	1	Thick Film, 14-pin DIP	73138	1899-152-0	RN403
TF-19 (2.0K)	1	Thick Film, 14-pin DIP	73138	899-1-R2K	RN404
TF-40	1	Resistor Network, 14-pin DIP	CTS	Special	RN405

TRANSISTORS

TG-66	4	PNP, Case TO-106	07263	2N5139	Q408,409,410,411
TG-68	2	NPN, Case TO-104	02735	2N5183	Q402,403
TG-90	4	PNP, Case TO-92	04713	2N404A	Q404,405,406,407
TG-110	1	PNP, Case TO-106	07263	2N5140	Q412

CAPACITORS

C22-.01M	1	0.01μF, 500V, CerD	72982	871Z5U0103M	C401
C22-4700P		4700pF, 500V, CerD	-	-	C404
C201-.01M	1	0.01μF, 50V, MPCb	14752	625B1A	C402

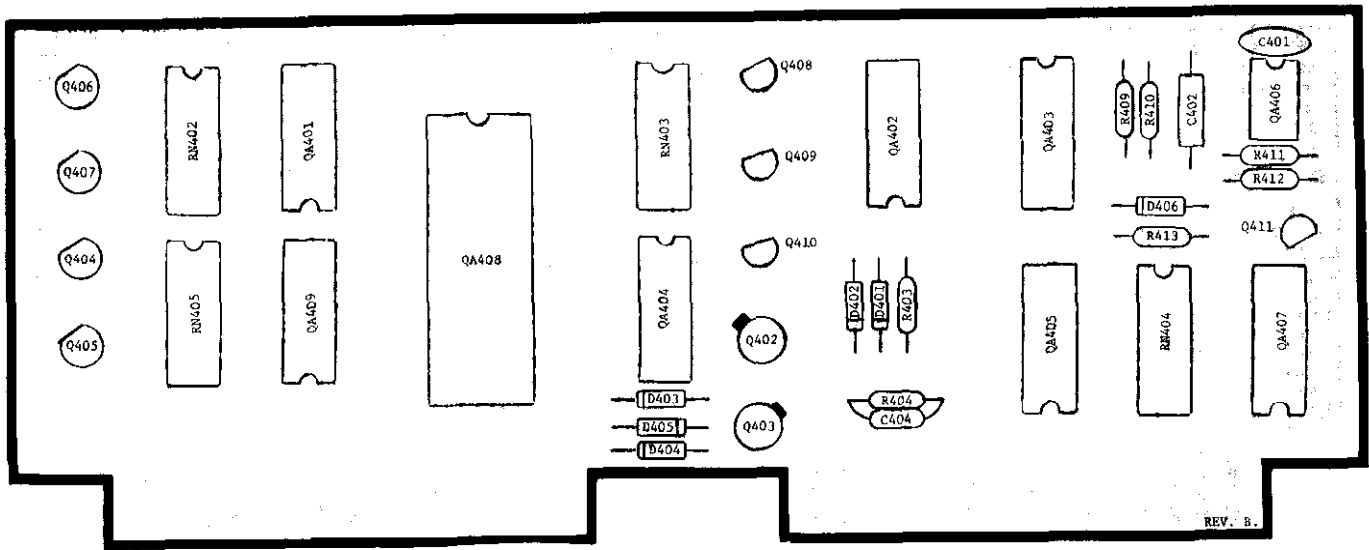

FIGURE 37. Component Layout, PC-323. (Logic Board)

RANGING BOARD

PC-324

CAPACITORS

Keithley Part No.	Quantity Per Assembly	Description	Mfr.	Mfr. Desig.	Circuit Desig.
C64-330P	1	330pF, 100V, CerD	71590	DD-331	C301
C178-.1M	1	0.1 μ F, 250V, MtF	73445	C280AE	C308
C201-.01M	1	0.01 μ F, 50V, MPC	14752	625B1A.01	C310
C201-.1M	1	0.1 μ F, 50V, MPC	14752	625B1A.1	C311
C228-39M	3	39 μ F, 15V, Epoxy	17554	TD401539610	C302,303,307
C237-.33M	1	0.33 μ F, 50V, CerF	72982	8131050651334M	C309
C245-1M	1	1.0 μ F, 100V, My	14752	230B1B105	C305
C22-.0033M	2	.0033 μ F, 500V, CerD	72982	801Z5U0332M	C304,306

MISCELLANEOUS

DN-2	1	Diode Network, 8-pin DIP		FSA2619M	DN301
DZ-41	1	Diode, Zener, 9V	06751	1N937	D304
RF-28	3	Diode, Rectifier	02195	1N914	D301-303

INTEGRATED CIRCUITS

IC-24	1	Analog Amplifier, 8-pin DIP	12040	LM301AN	QA305
IC-53	1	Transistor Array, 14-pin DIP	02735	CA3086	QA306
IC-74	1	Operational Amplifier, 8-pin DIP	32293	ITS6214	QA301
IC-76	2	Operational Amplifier, 8-pin DIP	07263	Special	QA302,303
IC-77	1	Operational Amplifier, 8-pin DIP	07263	Special	QA304

RESISTORS

R76-10K	1	10K Ω , 10%, 1/4W, Comp	01121	CB-103-10%	R312
R88-1K	1	1K Ω , 1%, 1/8W, MtF	07716	CEA-1K Ω	R306
R88-2K	1	2K Ω , 1%, 1/8W, MtF	07716	CEA-2K Ω	R310
R88-80.6K	1	80.6K Ω , 1%, 1/8W, MtF	07716	CEA-80.6K Ω	R313
R168-61.9K	2	61.9K Ω , 0.1%, 1/8W, MtF	91637	MFF-1/8-61.9K Ω	R301,302
RP89-500	2	Potentiometer, 500 Ω , .75W	73138	89P-500 Ω	R304,305
RP89-1K	2	Potentiometer, 1K Ω , .75W	73138	89P-1K Ω	R307,309
RP89-2K	1	Potentiometer, 2K Ω , .75W	73138	89P-2K Ω	R311
RP89-10K	1	Potentiometer, 10K Ω , .75W	73138	89P-10K Ω	R308
RP89-1M Ω	1	Potentiometer, 1M Ω , .75W	73138	89P-1M Ω ,	R303

RESISTOR NETWORKS

TF-2	1	Thick-Film, 16-pin DIP	80164	-----	RN303
TF-3	1	Thick-Film, 14-pin DIP	80164	-----	RN304
TF-5	1	Thick-Film, 16-pin DIP	73138	1898.64-0	RN302
TF-15	1	Thick-Film	80164	-----	RN301

TRANSISTORS

TG-61	1	PNP, Case TO-92	04713	2N5087	Q306
TG-97	4	N-Channel J-FET, Case TO-18	32293	ITS3538A	Q302,303,304,305
TG-98	1	Dual N-Channel J-FET, Case TO-71	32293	ITS30092	Q301
TG-110	1	PNP, Case TO-106	07263	2N5140	Q307

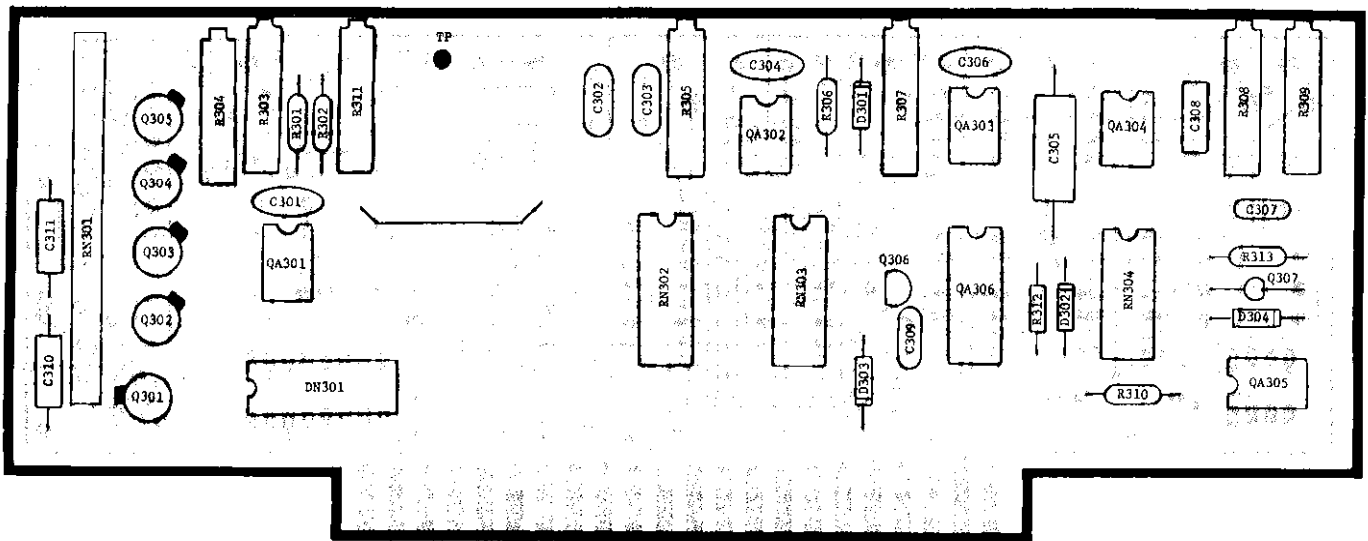

FIGURE 38. Component Layout, PC-324. (Ranging Board)

INPUT FET BOARD
PC-361

MISCELLANEOUS

Keithley Part No.	Quantity Per Assembly	Description	Mfr.	Mfr. Desig.	Circuit Desig.
C64-.001M	1	Capacitor, .001 μ F, 1000V, CerD	72982	808000Z5R0	C113
IC-74	1	Integrated Circuit, 8-pin DIP	32293	ITS6214	QA101

RESISTORS

R76-100K	1	100K Ω , 10%, 1/4W, Comp	01121	CB-104-10%	R124
R212-75K	2	75K Ω , 0.1%, 0.3W	18612	V53-1-75K Ω	R120,121
R168-100	1	100 Ω , 0.1%, 1/8W, MtF	91637	MFF-1/8-100	R122
RP89-200	1	200 Ω , .75W, Cermet	73138	89P-200 Ω	R123

TRANSISTORS

TG-39	2	NPN, Case TO-106	07263	2N3565	Q103,104
TG-91	1	Dual NPN, Case	32293	IT121	Q102
26612A	1	Matched pair, FET, Case TO-18 (selected TG-51)	RAY	RN1030	Q101, Q107

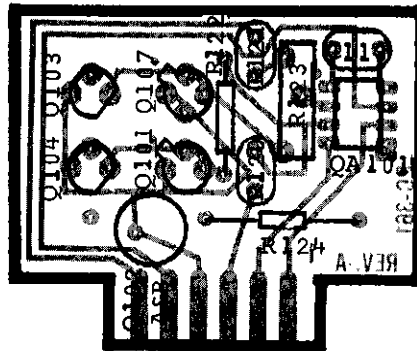

FIGURE 39. Component Layout, PC-361.

SCHEMATICS

Schematic diagrams are furnished to describe the Model 616 Digital Electrometer and the Model 6162 Isolated Output Control.

MODEL 616

<u>Schematic No.</u>	<u>Description</u>	<u>Page</u>
25777D	Power Supply for Model 616	63
25776D	Autoranging Amplifier	64
25764E	Electrometer Amplifier	65
25778E	LSI Circuit, Digital Logic	66

MODEL 6162

<u>Schematic No.</u>	<u>Description</u>	<u>Page</u>
25715D	Isolated/Output, Ranging	67
25716D	Isolated/Output, Data Lines	68
25717C	Isolated/Output, Decimal Point, Function	69
25823C	Power Supply for Model 6162	70

REV.	DATE	DESCRIPTION
1	2-7-72	INITIAL SCHEMATIC
2	2-7-72	REVISED SCHEMATIC
3	4-30-72	REVISED SCHEMATIC
4	5-8-72	REVISED SCHEMATIC
5	5-8-72	REVISED SCHEMATIC
6	5-8-72	REVISED SCHEMATIC

TO COLLECTOR OF Q105
(SCHEMATIC # 25764E)

(SCHEMATIC # 25764E)

TO COLLECTOR OF Q106
(SCHEMATIC # 25764E)

(SCHEMATIC # 25764E)

(SCHEMATIC # 25764E)

(SCHEMATIC # 25764E)

(SCHEMATIC # 25764E)

(SCHEMATIC # 25764E)

(SCHEMATIC # 25764E)

(SCHEMATIC # 25764E)

(SCHEMATIC # 25764E)

(SCHEMATIC # 25764E)

(SCHEMATIC # 25764E)

(SCHEMATIC # 25764E)

(SCHEMATIC # 25764E)

(SCHEMATIC # 25764E)

(SCHEMATIC # 25764E)

(SCHEMATIC # 25764E)

(SCHEMATIC # 25764E)

(SCHEMATIC # 25764E)

(SCHEMATIC # 25764E)

(SCHEMATIC # 25764E)

(SCHEMATIC # 25764E)

(SCHEMATIC # 25764E)

(SCHEMATIC # 25764E)

(SCHEMATIC # 25764E)

(SCHEMATIC # 25764E)

(SCHEMATIC # 25764E)

(SCHEMATIC # 25764E)

(SCHEMATIC # 25764E)

(SCHEMATIC # 25764E)

(SCHEMATIC # 25764E)

(SCHEMATIC # 25764E)

(SCHEMATIC # 25764E)

(SCHEMATIC # 25764E)

(SCHEMATIC # 25764E)

(SCHEMATIC # 25764E)

(SCHEMATIC # 25764E)

(SCHEMATIC # 25764E)

(SCHEMATIC # 25764E)

(SCHEMATIC # 25764E)

(SCHEMATIC # 25764E)

(SCHEMATIC # 25764E)

(SCHEMATIC # 25764E)

(SCHEMATIC # 25764E)

(SCHEMATIC # 25764E)

(SCHEMATIC # 25764E)

(SCHEMATIC # 25764E)

(SCHEMATIC # 25764E)

(SCHEMATIC # 25764E)

(SCHEMATIC # 25764E)

(SCHEMATIC # 25764E)

(SCHEMATIC # 25764E)

(SCHEMATIC # 25764E)

(SCHEMATIC # 25764E)

(SCHEMATIC # 25764E)

(SCHEMATIC # 25764E)

(SCHEMATIC # 25764E)

(SCHEMATIC # 25764E)

(SCHEMATIC # 25764E)

(SCHEMATIC # 25764E)

(SCHEMATIC # 25764E)

(SCHEMATIC # 25764E)

(SCHEMATIC # 25764E)

(SCHEMATIC # 25764E)

(SCHEMATIC # 25764E)

(SCHEMATIC # 25764E)

(SCHEMATIC # 25764E)

(SCHEMATIC # 25764E)

(SCHEMATIC # 25764E)

(SCHEMATIC # 25764E)

(SCHEMATIC # 25764E)

(SCHEMATIC # 25764E)

(SCHEMATIC # 25764E)

(SCHEMATIC # 25764E)

(SCHEMATIC # 25764E)

(SCHEMATIC # 25764E)

(SCHEMATIC # 25764E)

(SCHEMATIC # 25764E)

(SCHEMATIC # 25764E)

(SCHEMATIC # 25764E)

(SCHEMATIC # 25764E)

(SCHEMATIC # 25764E)

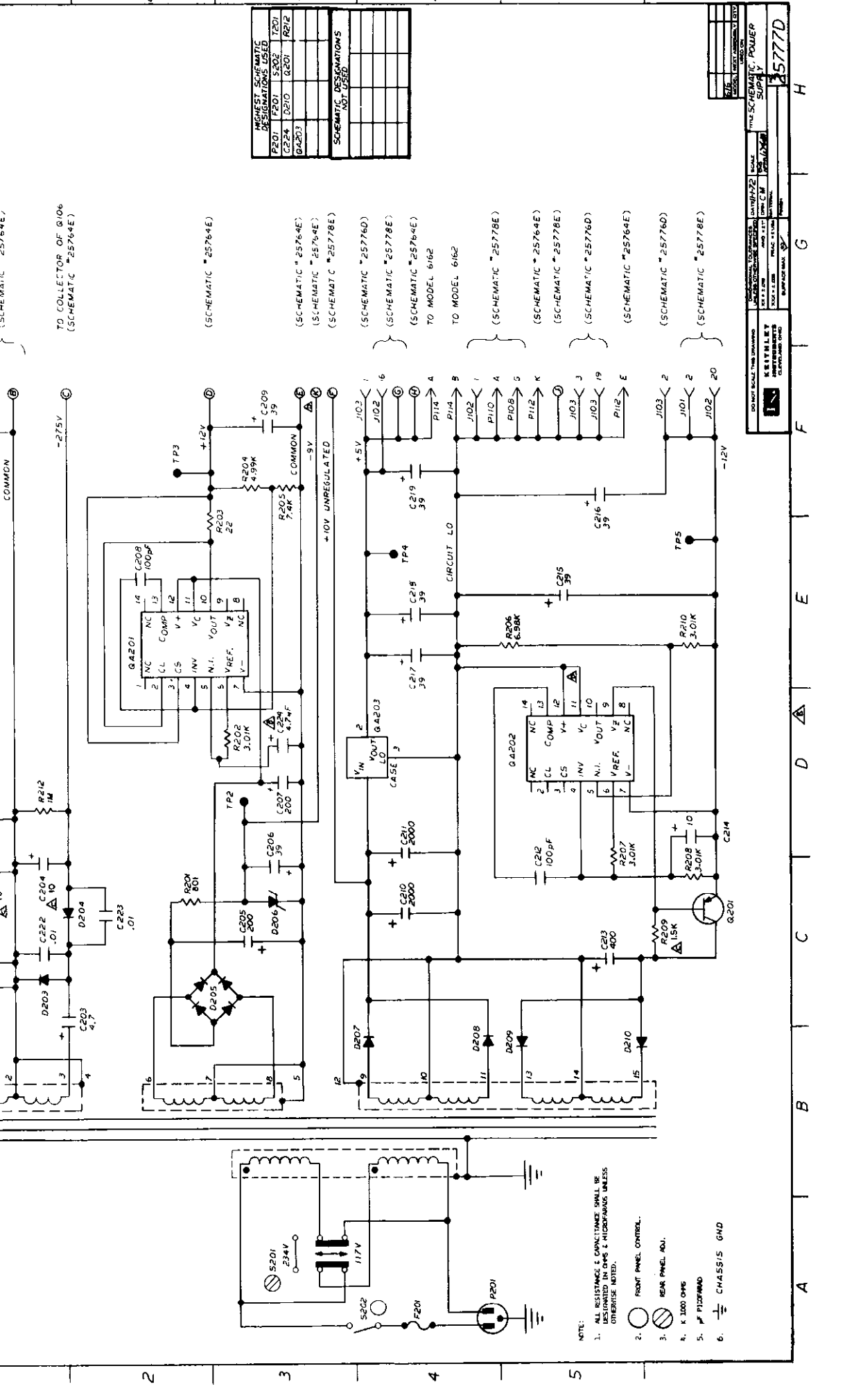

HIGHEST SCHEMATIC DESIGNATIONS USED
P201 P201 S202 T201
C224 D210 Q201 R212
Q203
SCHEMATIC DESIGNATIONS NOT USED

TO COLLECTOR OF Q105
(SCHEMATIC # 25764E)

(SCHEMATIC # 25764E)

TO COLLECTOR OF Q106
(SCHEMATIC # 25764E)

(SCHEMATIC # 25764E)

(SCHEMATIC # 25764E)

(SCHEMATIC # 25764E)

(SCHEMATIC # 25764E)

(SCHEMATIC # 25764E)

(SCHEMATIC # 25764E)

(SCHEMATIC # 25764E)

(SCHEMATIC # 25764E)

(SCHEMATIC # 25764E)

(SCHEMATIC # 25764E)

(SCHEMATIC # 25764E)

(SCHEMATIC # 25764E)

(SCHEMATIC # 25764E)

(SCHEMATIC # 25764E)

(SCHEMATIC # 25764E)

(SCHEMATIC # 25764E)

(SCHEMATIC # 25764E)

(SCHEMATIC # 25764E)

(SCHEMATIC # 25764E)

(SCHEMATIC # 25764E)

(SCHEMATIC # 25764E)

(SCHEMATIC # 25764E)

(SCHEMATIC # 25764E)

(SCHEMATIC # 25764E)

(SCHEMATIC # 25764E)

(SCHEMATIC # 25764E)

(SCHEMATIC # 25764E)

(SCHEMATIC # 25764E)

(SCHEMATIC # 25764E)

(SCHEMATIC # 25764E)

(SCHEMATIC # 25764E)

(SCHEMATIC # 25764E)

(SCHEMATIC # 25764E)

(SCHEMATIC # 25764E)

(SCHEMATIC # 25764E)

(SCHEMATIC # 25764E)

(SCHEMATIC # 25764E)

(SCHEMATIC # 25764E)

(SCHEMATIC # 25764E)

(SCHEMATIC # 25764E)

(SCHEMATIC # 25764E)

(SCHEMATIC # 25764E)

(SCHEMATIC # 25764E)

(SCHEMATIC # 25764E)

(SCHEMATIC # 25764E)

(SCHEMATIC # 25764E)

(SCHEMATIC # 25764E)

(SCHEMATIC # 25764E)

(SCHEMATIC # 25764E)

(SCHEMATIC # 25764E)

(SCHEMATIC # 25764E)

(SCHEMATIC # 25764E)

(SCHEMATIC # 25764E)

(SCHEMATIC # 25764E)

(SCHEMATIC # 25764E)

(SCHEMATIC # 25764E)

(SCHEMATIC # 25764E)

(SCHEMATIC # 25764E)

(SCHEMATIC # 25764E)

(SCHEMATIC # 25764E)

027752

DO NOT SCALE THIS DRAWING

KEYTLEY INSTRUMENTS

DATE: 2-7-72

SCALE: AS SHOWN

PROJECT: 15777D

15777D

NOTE:

- ALL RESISTORS & CAPACITORS SHALL BE 1% TOLERANCE UNLESS OTHERWISE NOTED.
- FRONT PANEL CONTROL.
- REAR PANEL ADJ.
- 1.000 OHMS
- P FIDELITY
- CHASSIS GND

REV	NO	DATE	BY	DESCRIPTION
A	2787	7/15	WJL	REVISED
B	2787	7/15	WJL	REVISED
C	2787	7/15	WJL	REVISED
D	2787	7/15	WJL	REVISED
E	2787	7/15	WJL	REVISED
F	2787	7/15	WJL	REVISED
G	2787	7/15	WJL	REVISED
H	2787	7/15	WJL	REVISED
I	2787	7/15	WJL	REVISED
J	2787	7/15	WJL	REVISED
K	2787	7/15	WJL	REVISED
L	2787	7/15	WJL	REVISED
M	2787	7/15	WJL	REVISED
N	2787	7/15	WJL	REVISED
O	2787	7/15	WJL	REVISED
P	2787	7/15	WJL	REVISED
Q	2787	7/15	WJL	REVISED
R	2787	7/15	WJL	REVISED
S	2787	7/15	WJL	REVISED
T	2787	7/15	WJL	REVISED
U	2787	7/15	WJL	REVISED

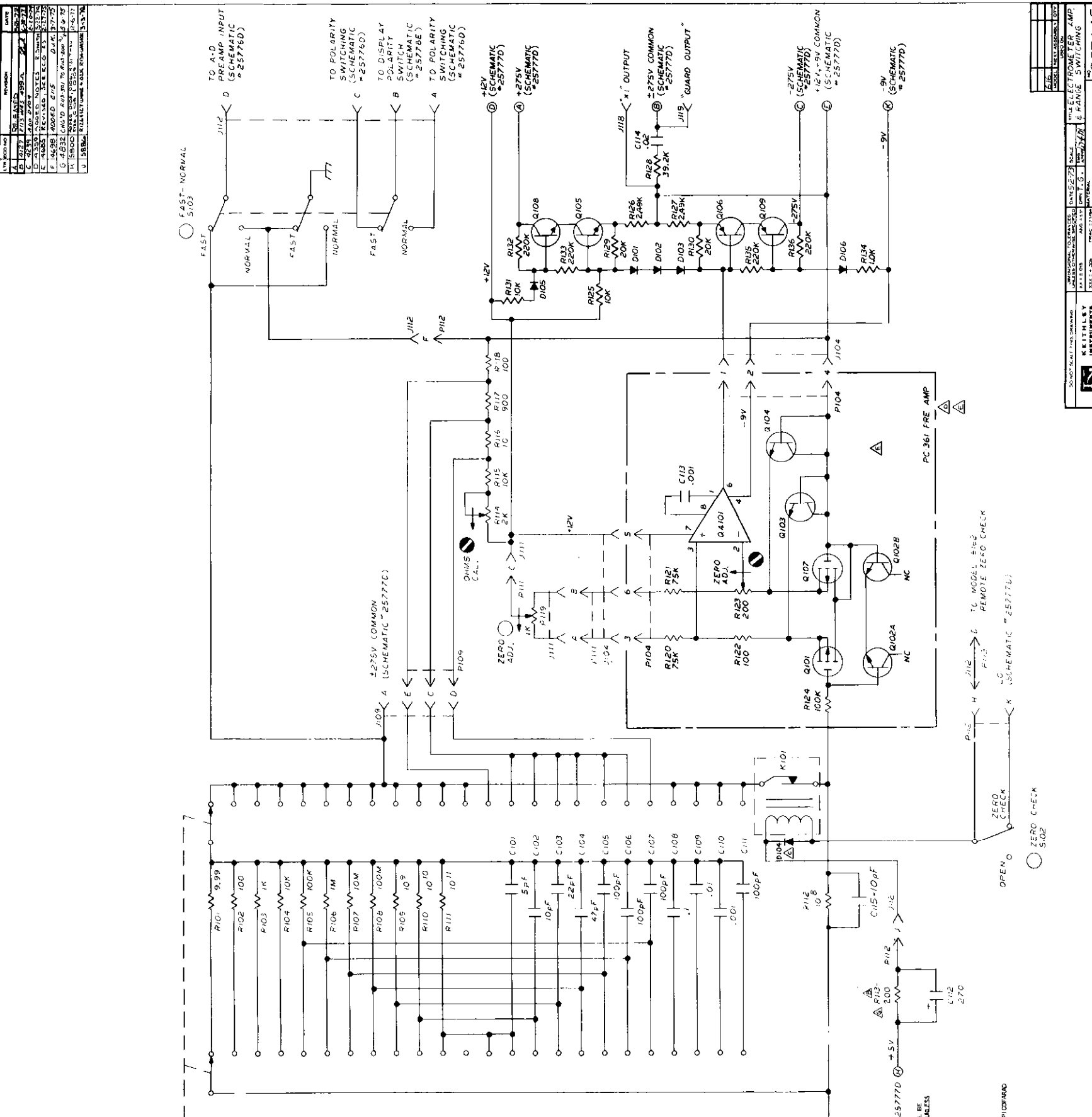
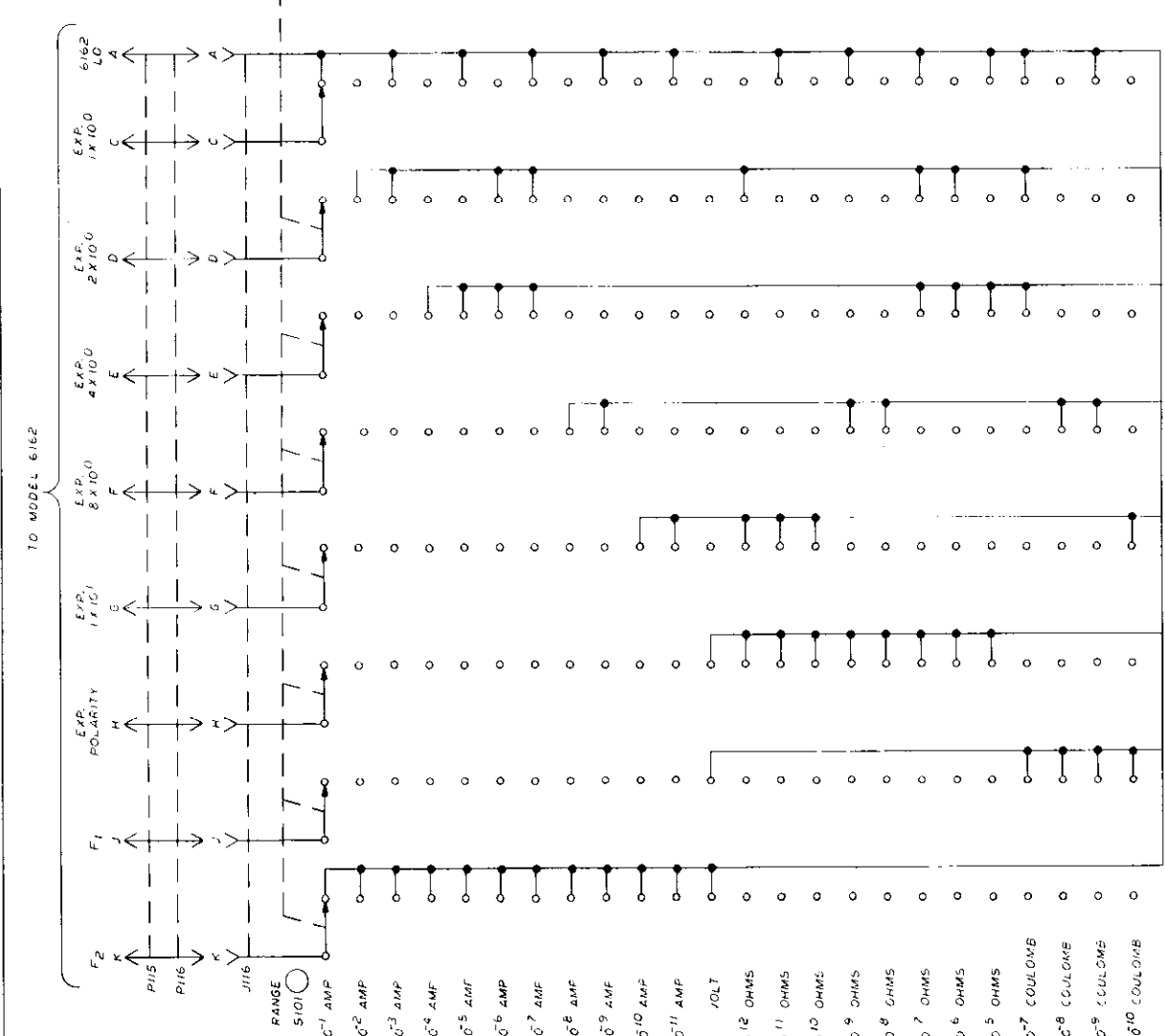

NOTE: 1. ALL RESISTANCE & CAPACITANCE SHALL BE DESIGNATED IN OHMS & MICROFARADS UNLESS OTHERWISE NOTED.
 2. FRONT PANEL CONTROL.
 3. INTERNAL SUBSTITUTED ADJ.
 4. M RESOM X 100 OHMS P² P100P400
 5. CLOSURE ROTATION
 6. POWER SUPPLY GND
 7. CHASSIS GND

HIGHEST SCHEMATIC DESIGNATIONS USED		
R136	Q109	P116
C115	K101	S103
D106	S103	
G101	J123	

SCHEMATIC DESIGNATIONS NOT USED		

DATE	2787	7/15
BY	WJL	
REVISED		
DATE		
BY		
REVISED		
DATE		
BY		
REVISED		
DATE		
BY		
REVISED		

WEITHELY ELECTRONIC CORP.
 1500 WASHINGTON BLVD.
 WASHINGTON, D.C. 20004
 TELEPHONE: 202-546-7000
 FAX: 202-546-7001

25764E

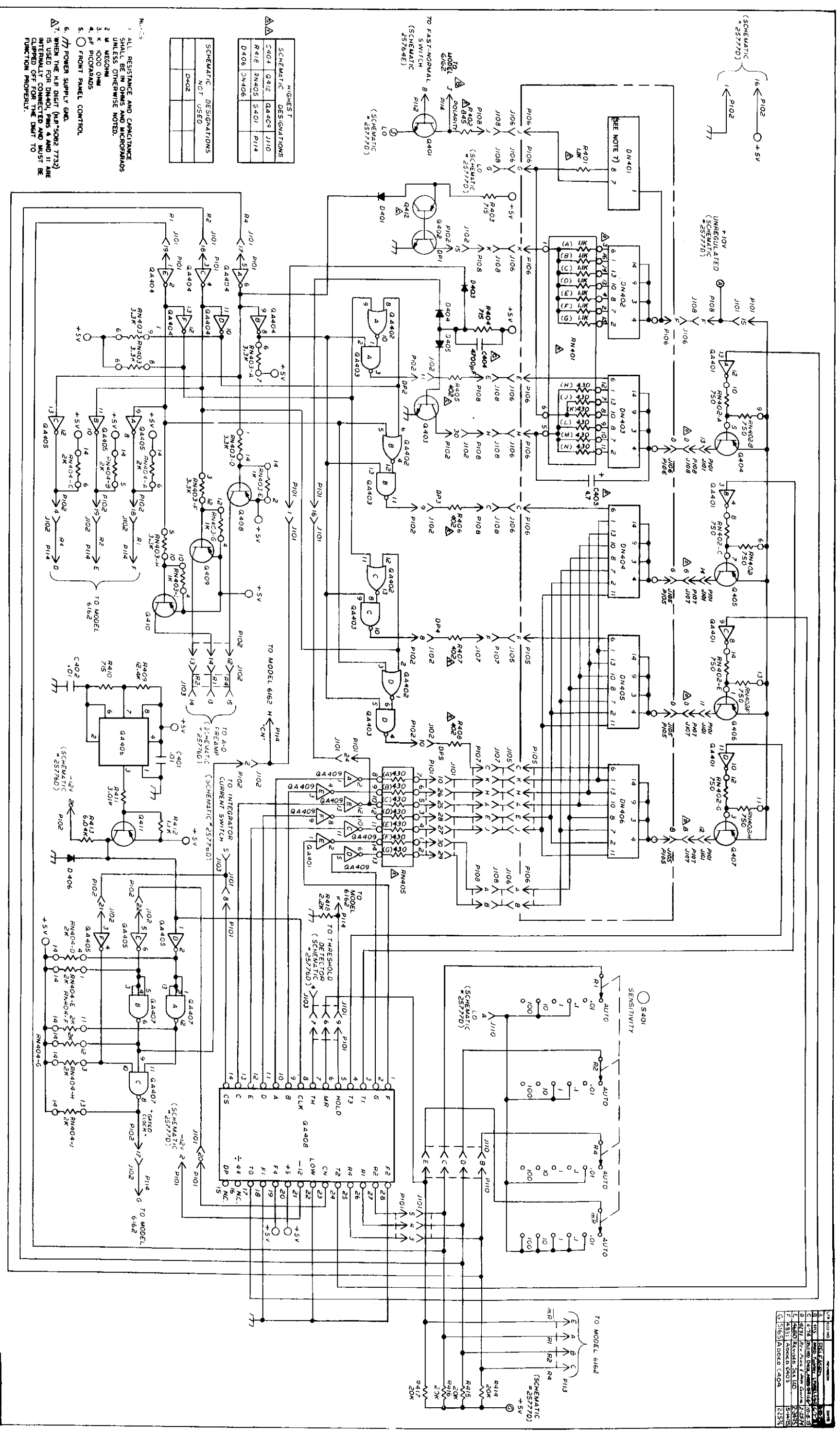

HIGHEST SCHEMATIC DESIGNATIONS

Q401	Q412	Q4409	J110
R418	R405	S401	P114
D406	DN406		

SCHEMATIC DESIGNATIONS NOT USED

	D402	
--	------	--

- NOTES
1. ALL RESISTANCE AND CAPACITANCE SHALL BE IN OHMS AND MICROFARADS UNLESS OTHERWISE NOTED.
 2. M = MEGOHM
 3. K = 1000 OHM
 4. P = PICOFARADS
 5. ○ = FRONT PANEL CONTROL
 6. // POWER SUPPLY GND.
 7. WHEN THE R.P. DIGIT (R.P. 5082 7732) IS USED FOR DN401, PINS 4 AND 11 ARE INTERNALLY CONNECTED AND MUST BE CLIPPED OFF FOR THE DIGIT TO FUNCTION PROPERLY.

Part No.	Description	Quantity
Q4408	Q4408	1
Q4401	Q4401	1
Q4402	Q4402	1
Q4403	Q4403	1
Q4404	Q4404	1
Q4405	Q4405	1
Q4406	Q4406	1
Q4407	Q4407	1
Q4409	Q4409	1
R401	R401	1
R402	R402	1
R403	R403	1
R404	R404	1
R405	R405	1
R406	R406	1
R407	R407	1
R408	R408	1
R409	R409	1
R410	R410	1
R411	R411	1
R412	R412	1
R413	R413	1
R414	R414	1
R415	R415	1
R416	R416	1
R417	R417	1
R418	R418	1
R419	R419	1
R420	R420	1
R421	R421	1
R422	R422	1
R423	R423	1
R424	R424	1
R425	R425	1
R426	R426	1
R427	R427	1
R428	R428	1
R429	R429	1
R430	R430	1
R431	R431	1
R432	R432	1
R433	R433	1
R434	R434	1
R435	R435	1
R436	R436	1
R437	R437	1
R438	R438	1
R439	R439	1
R440	R440	1
R441	R441	1
R442	R442	1
R443	R443	1
R444	R444	1
R445	R445	1
R446	R446	1
R447	R447	1
R448	R448	1
R449	R449	1
R450	R450	1
R451	R451	1
R452	R452	1
R453	R453	1
R454	R454	1
R455	R455	1
R456	R456	1
R457	R457	1
R458	R458	1
R459	R459	1
R460	R460	1
R461	R461	1
R462	R462	1
R463	R463	1
R464	R464	1
R465	R465	1
R466	R466	1
R467	R467	1
R468	R468	1
R469	R469	1
R470	R470	1
R471	R471	1
R472	R472	1
R473	R473	1
R474	R474	1
R475	R475	1
R476	R476	1
R477	R477	1
R478	R478	1
R479	R479	1
R480	R480	1
R481	R481	1
R482	R482	1
R483	R483	1
R484	R484	1
R485	R485	1
R486	R486	1
R487	R487	1
R488	R488	1
R489	R489	1
R490	R490	1
R491	R491	1
R492	R492	1
R493	R493	1
R494	R494	1
R495	R495	1
R496	R496	1
R497	R497	1
R498	R498	1
R499	R499	1
R500	R500	1
C401	C401	1
C402	C402	1
D401	D401	1
D402	D402	1
D403	D403	1
D404	D404	1
D405	D405	1
D406	D406	1
DN401	DN401	1
DN402	DN402	1
DN403	DN403	1
DN404	DN404	1
DN405	DN405	1
DN406	DN406	1
J101	J101	1
J102	J102	1
J103	J103	1
J104	J104	1
J105	J105	1
J106	J106	1
J107	J107	1
J108	J108	1
J109	J109	1
J110	J110	1
P101	P101	1
P102	P102	1
P103	P103	1
P104	P104	1
P105	P105	1
P106	P106	1
P107	P107	1
P108	P108	1
P109	P109	1
P110	P110	1
P111	P111	1
P112	P112	1
P113	P113	1
P114	P114	1
S401	S401	1

REV.	DATE	REVISION
1	11/13/62	INITIAL SCHEMATIC
2	11/13/62	REVISION 1
3	11/13/62	REVISION 2

6162-616 INTERCONNECTING CABLE		
6162	616	616
J101-A	J114-B	J102-D
J101-B	J114-C	J102-E
J101-C	J114-D	J102-F
J101-D	J114-E	J102-G
J101-E	J114-F	J102-H
J101-F	J114-G	J102-I
J101-G	J114-H	J102-J
J101-H	J114-I	J102-K
J101-I	J114-J	J102-L
J101-J	J114-K	J102-M
J101-K	J114-L	J102-N
J101-L	J114-M	J102-O
J101-M	J114-N	J102-P
J101-N	J114-O	J102-Q
J101-O	J114-P	J102-R
J101-P	J114-Q	J102-S
J101-Q	J114-R	J102-T
J101-R	J114-S	J102-U
J101-S	J114-T	J102-V
J101-T	J114-U	J102-W
J101-U	J114-V	J102-X
J101-V	J114-W	J102-Y
J101-W	J114-X	J102-Z

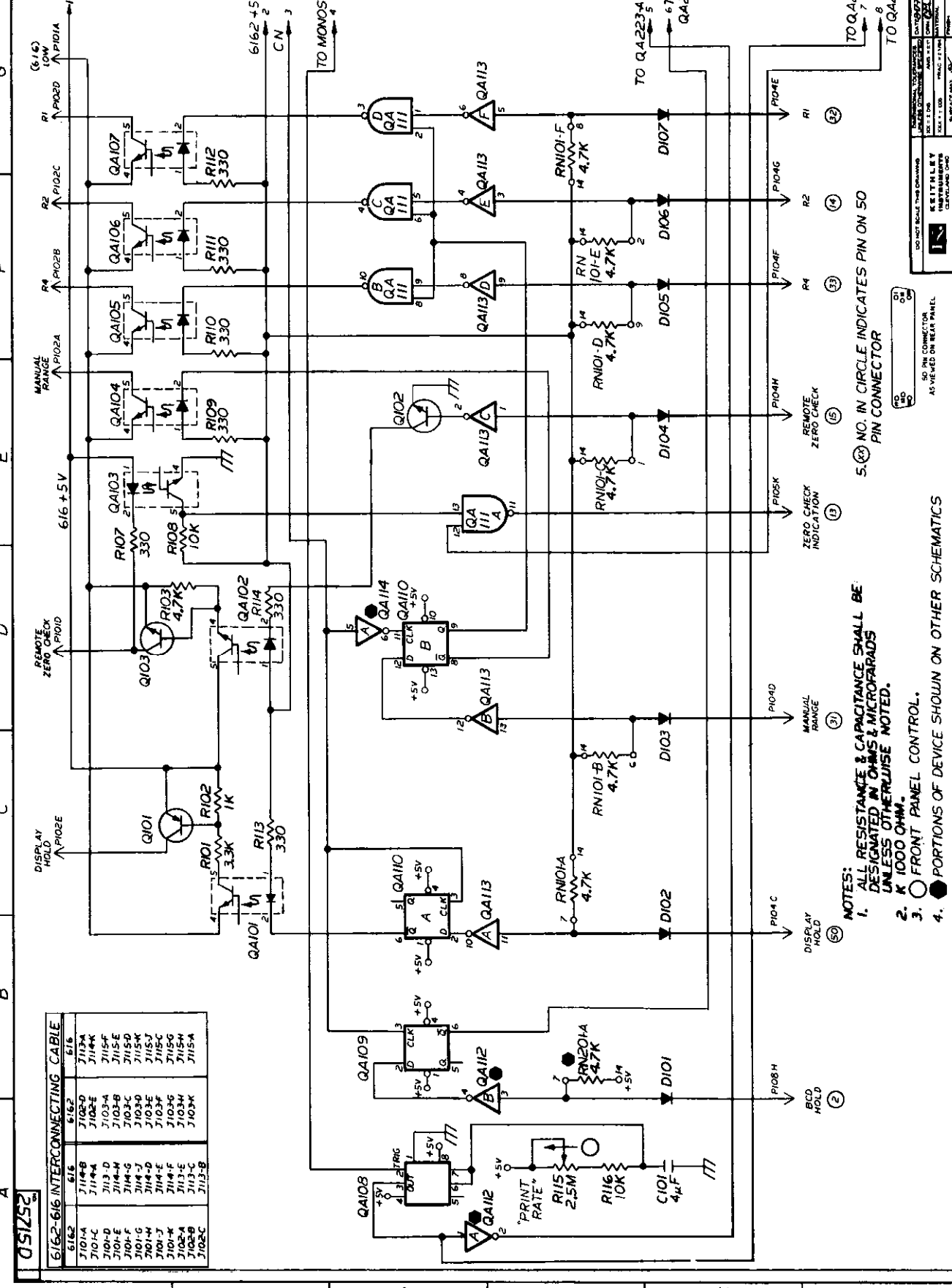

05152

6162-616 INTERCONNECTING CABLE		
6162	616	616
J101-A	J114-B	J102-D
J101-B	J114-C	J102-E
J101-C	J114-D	J102-F
J101-D	J114-E	J102-G
J101-E	J114-F	J102-H
J101-F	J114-G	J102-I
J101-G	J114-H	J102-J
J101-H	J114-I	J102-K
J101-I	J114-J	J102-L
J101-J	J114-K	J102-M
J101-K	J114-L	J102-N
J101-L	J114-M	J102-O
J101-M	J114-N	J102-P
J101-N	J114-O	J102-Q
J101-O	J114-P	J102-R
J101-P	J114-Q	J102-S
J101-Q	J114-R	J102-T
J101-R	J114-S	J102-U
J101-S	J114-T	J102-V
J101-T	J114-U	J102-W
J101-U	J114-V	J102-X
J101-V	J114-W	J102-Y
J101-W	J114-X	J102-Z

NOTES:

1. ALL RESISTANCE & CAPACITANCE SHALL BE DESIGNATED IN OHMS & MICROGRADS UNLESS OTHERWISE NOTED.
2. K 1000 OHM.
3. ○ FRONT PANEL CONTROL.
4. ● PORTIONS OF DEVICE SHOWN ON OTHER SCHEMATICS

5. (X) NO. IN CIRCLE INDICATES PIN ON 50 PIN CONNECTOR

50 PIN CONNECTOR AS VIEWED ON REAR PANEL

DO NOT SCALE THIS DRAWING

DATE: 11/13/62

SCALE: 1/8" = 1"

DESIGNED BY: [Signature]

CHECKED BY: [Signature]

APPROVED BY: [Signature]

PROJECT NO. 25715D

REV. 1

DATE: 11/13/62

05152

6162-616 INTERCONNECTING CABLE		
6162	616	616
J101-A	J114-B	J102-D
J101-B	J114-C	J102-E
J101-C	J114-D	J102-F
J101-D	J114-E	J102-G
J101-E	J114-F	J102-H
J101-F	J114-G	J102-I
J101-G	J114-H	J102-J
J101-H	J114-I	J102-K
J101-I	J114-J	J102-L
J101-J	J114-K	J102-M
J101-K	J114-L	J102-N
J101-L	J114-M	J102-O
J101-M	J114-N	J102-P
J101-N	J114-O	J102-Q
J101-O	J114-P	J102-R
J101-P	J114-Q	J102-S
J101-Q	J114-R	J102-T
J101-R	J114-S	J102-U
J101-S	J114-T	J102-V
J101-T	J114-U	J102-W
J101-U	J114-V	J102-X
J101-V	J114-W	J102-Y
J101-W	J114-X	J102-Z

NOTES:

1. ALL RESISTANCE & CAPACITANCE SHALL BE DESIGNATED IN OHMS & MICROGRADS UNLESS OTHERWISE NOTED.
2. K 1000 OHM.
3. ○ FRONT PANEL CONTROL.
4. ● PORTIONS OF DEVICE SHOWN ON OTHER SCHEMATICS

5. (X) NO. IN CIRCLE INDICATES PIN ON 50 PIN CONNECTOR

50 PIN CONNECTOR AS VIEWED ON REAR PANEL

DO NOT SCALE THIS DRAWING

DATE: 11/13/62

SCALE: 1/8" = 1"

DESIGNED BY: [Signature]

CHECKED BY: [Signature]

APPROVED BY: [Signature]

PROJECT NO. 25715D

REV. 1

DATE: 11/13/62

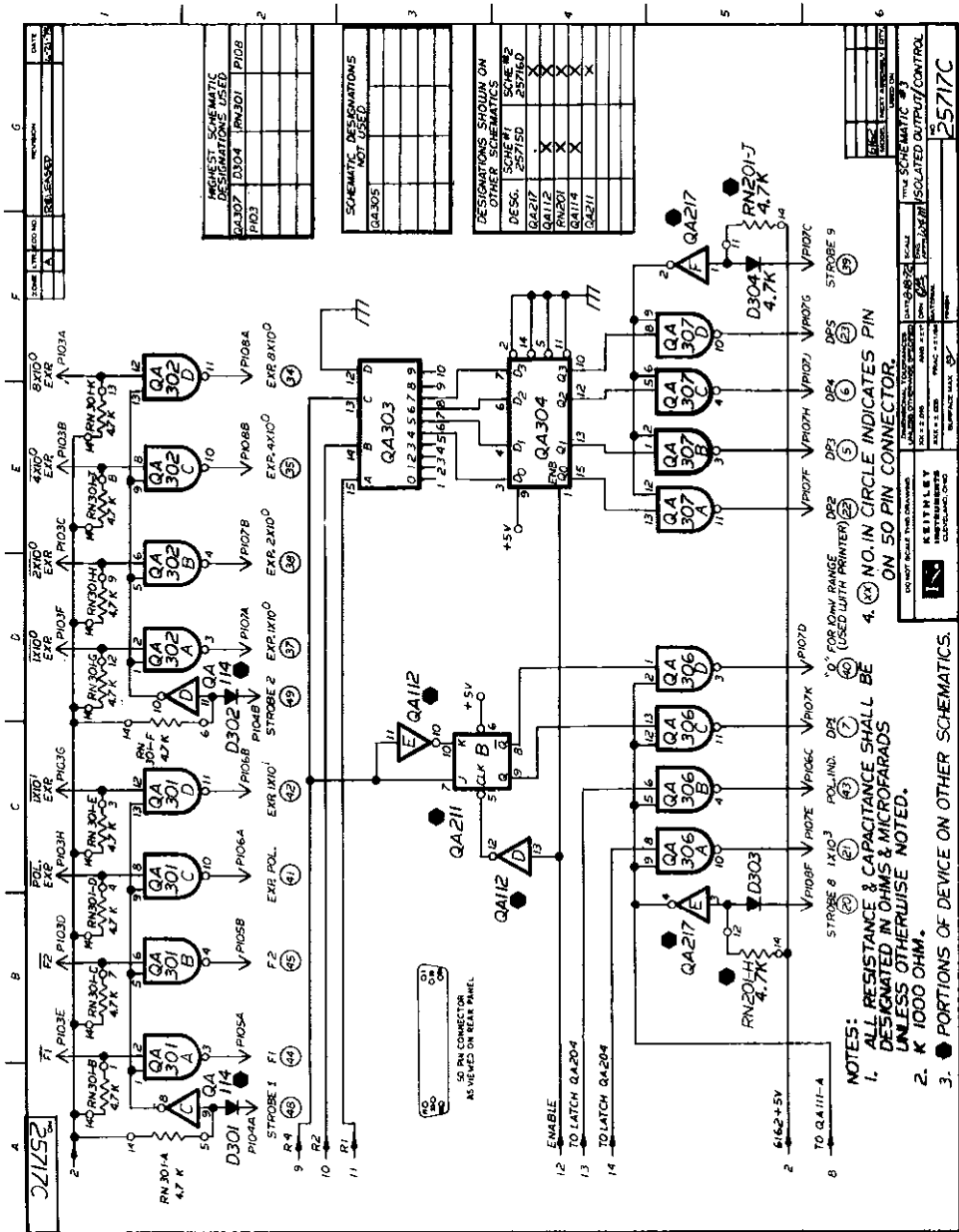

FORM	TYPE	REV	DATE
1	A	1	10/15/52

DATE	10/15/52
DESIGNED BY	W. J. B. / J. S. / J. S.
CHECKED BY	
APPROVED BY	
REVISIONS	

HIGHEST SCHEMATIC DESIGNATIONS USED	
QA307	DD04 (RN301) PI08
PI03	

SCHEMATIC DESIGNATIONS NOT USED	
QA305	

DESIGNATIONS SHOWN ON OTHER SCHEMATICS	
DESC.	SCHEMATIC
QA217	EST. 25710
QA112	X
RN201	X
QA114	X
QA211	X

DESIGNATIONS SHOWN ON OTHER SCHEMATICS	
DESC.	SCHEMATIC
QA217	EST. 25710
QA112	X
RN201	X
QA114	X
QA211	X

NOTES:

1. ALL RESISTANCE & CAPACITANCE SHALL BE DESIGNATED IN OHMS & MICROFARADS UNLESS OTHERWISE NOTED.
2. K 1000 OHM.
3. ● PORTIONS OF DEVICE ON OTHER SCHEMATICS.

STROBE 8 1X10³ POL. IND. DCR 0° FOR OHM RANGE DER (USED WITH PRINTER) (2) (5) (6) (7) (8) (9) (10) (11) (12) (13) (14) (15) (16) (17) (18) (19) (20) (21) (22) (23) (24) (25) (26) (27) (28) (29) (30) (31) (32) (33) (34) (35) (36) (37) (38) (39) (40) (41) (42) (43) (44) (45) (46) (47) (48) (49) (50)

4. ● IN CIRCLE INDICATES PIN ON 50 PIN CONNECTOR.

DATE	10/15/52
DESIGNED BY	W. J. B. / J. S. / J. S.
CHECKED BY	
APPROVED BY	
REVISIONS	

25717C

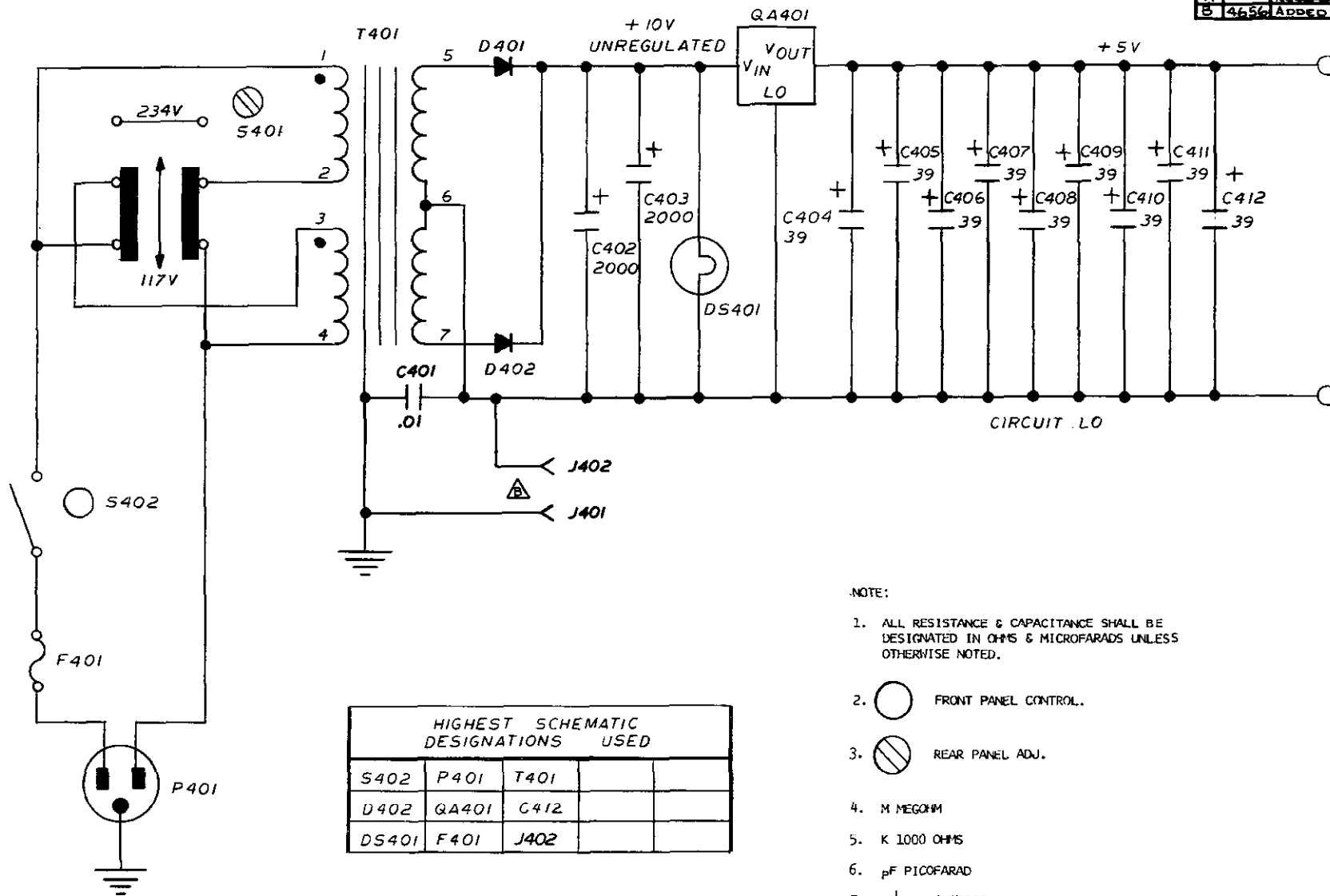

NOTE:

1. ALL RESISTANCE & CAPACITANCE SHALL BE DESIGNATED IN OHMS & MICROFARADS UNLESS OTHERWISE NOTED.
2. ○ FRONT PANEL CONTROL.
3. ◐ REAR PANEL ADJ.
4. M MEGOHM
5. K 1000 OHMS
6. pF PICOFARAD
7. ⊥ CHASSIS GND

HIGHEST SCHEMATIC DESIGNATIONS USED				
S402	P401	T401		
D402	QA401	C412		
DS401	F401	J402		

SCHEMATIC DESIGNATIONS NOT USED				

6162		
MODEL	NEXT ASSEMBLY	QTY.
USED ON		

DO NOT SCALE THIS DRAWING	DIMENSIONAL TOLERANCES UNLESS OTHERWISE SPECIFIED	DATE 4/4/73	SCALE	TITLE POWER SUPPLY
KEITHLEY INSTRUMENTS CLEVELAND, OHIO	XX - 2.010	ANG - ±1°	DRN: GEC/JVA	ENG: APPROV: JFM
	XXX - ±.005	FRAC. - ±1/64	MATERIAL	
	SURFACE MAX. 63	FINISH		5823C

SERVICE FORM

MODEL NO. _____ SERIAL NO. _____ P.O. NO. _____ DATE _____ R-

NAME _____ PHONE _____

COMPANY _____

ADDRESS _____ CITY _____ STATE _____ ZIP _____

1. Describe problem and symptoms using quantitative data whenever possible (enclose readings, chart recordings, etc.) _____

_____ (Attach additional sheets as necessary).

2. Show a block diagram of your measurement system including all instruments connected (whether power is turned on or not). Also describe signal source.

3. List the positions of all controls and switches on both front and rear panels of the instrument. _____

4. Describe input signal source levels, frequencies, etc. _____

5. List and describe all cables used in the experiment (length, shielding, etc.).

6. List and describe all other equipment used in the experiment. Give control settings for each. _____

7. Environment:
Where is the measurement being performed? (Factory, controlled laboratory, out-of-doors, etc.) _____
What power line voltage is used? _____ Variation? _____ Frequency? _____
Ambient temperature? _____°F. Variation? _____°F. Rel. Humidity? _____
Other _____

8. Additional Information. (If special modifications have been made by the user, please describe below.) _____

Instruction Manual Addendum Model 616 Digital Electrometer

The following information is supplied as a supplement to this manual in order to provide the user with the latest improvements in the least possible time. It is recommended that the information supplied in this addendum be incorporated into the appropriate places in the manual immediately.

Description Of Changes

Most changes included with this addendum concern the plug-in pre amp (PC-361), which is replaced with one of two versions of the pre amp (PC-601 or PC-602). Additionally, some parts elsewhere in the instrument have been changed, added, or deleted.

Schematic Changes

The following schematic diagram has been revised and is included with this addendum: Electrometer Amplifier, drawing number 25764E, page 65.

Component Layout Changes

Delete Figure 39 of the manual (PC-361) and replace it with component layout drawing numbers 32048 (PC-601) and 32053 (PC-602).

Parts List Changes

1. Delete the PC-361 parts list of the manual on page 60 and replace it with Table 1 of this addendum.
2. PC-321, parts list, page 51: Change parts as listed in Table 2.

Table 1. Parts List For PC-601 and PC-602

Circuit Desig.	Description	Keithley Part No.
C113	Capacitor, 0.01 μ F, \pm 20%, 500V, Ceramic Disc	C-22-.01
C117	Capacitor, 10pF, \pm 20%, 1000V, Ceramic Disc	C-64-10pF
Q101*	Transistor, matched pair with Q107	A26612*
Q101**	Transistor, Selected	A31484**
Q102	Transistor, Dual NPN, IT121	TG-91
Q103	Transistor, NPN Silicon, 2N3565	TG-39
Q104	Transistor, NPN Silicon, 2N3565	TG-39
Q107*	Transistor, matched pair with Q101	A26612*
R120	Resistor, 75k Ω , 0.1%, 1/10W	R-212-75k
R121	Resistor, 75k Ω , 0.1%, 1/10W	R-212-75k
R122	Resistor, 100 Ω , 0.1%, 1/8W, Metal Film	R-168-100
R123	Potentiometer, 200 Ω , 0.75W	RP-89-200
R124	Resistor, 100k Ω , 5%, 1/4W, Composition	R-76-100k
R137	Resistor, 20k Ω , 5%, 1/4W, Composition	R-76-20k
U101	IC, Operational Amplifier, 8-pin DIP, ITS6214 Pre Amp, assembled with all parts	IC-74 32053†

*PC-602 only

**PC-601 only

† PC-321 must be modified if used in place of PC-361

Table 2. PC-321 Parts Changes

Circuit Desig.	Action	Description	Keithley Part No.
C112	Changed	Capacitor, 250 μ F, 25V, Aluminum Electrolytic	C-314-250
C114	Changed	Capacitor, 1000pF, 100V, Ceramic Disc	C-64-1000pF
C206	Changed	Capacitor, 47 μ F, 16V, Aluminum Electrolytic	C-321-47
C209	Changed	Capacitor, 47 μ F, 16V, Aluminum Electrolytic	C-321-47
C214	Changed	Capacitor, 10 μ F, 25V, Aluminum Electrolytic	C-314-10
C215	Changed	Capacitor, 47 μ F, 16V, Aluminum Electrolytic	C-321-47
C216	Changed	Capacitor, 47 μ F, 16V, Aluminum Electrolytic	C-321-47
C217	Changed	Capacitor, 47 μ F, 16V, Aluminum Electrolytic	C-321-47
C218	Changed	Capacitor, 47 μ F, 16V, Aluminum Electrolytic	C-321-47
C219	Changed	Capacitor, 47 μ F, 16V, Aluminum Electrolytic	C-321-47
R128	Deleted		

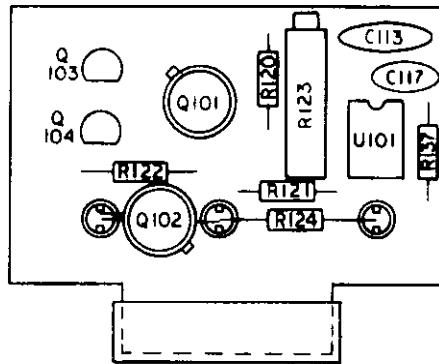

Figure 39. Component Layout, PC-601

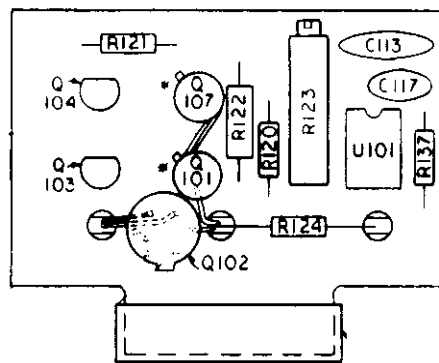
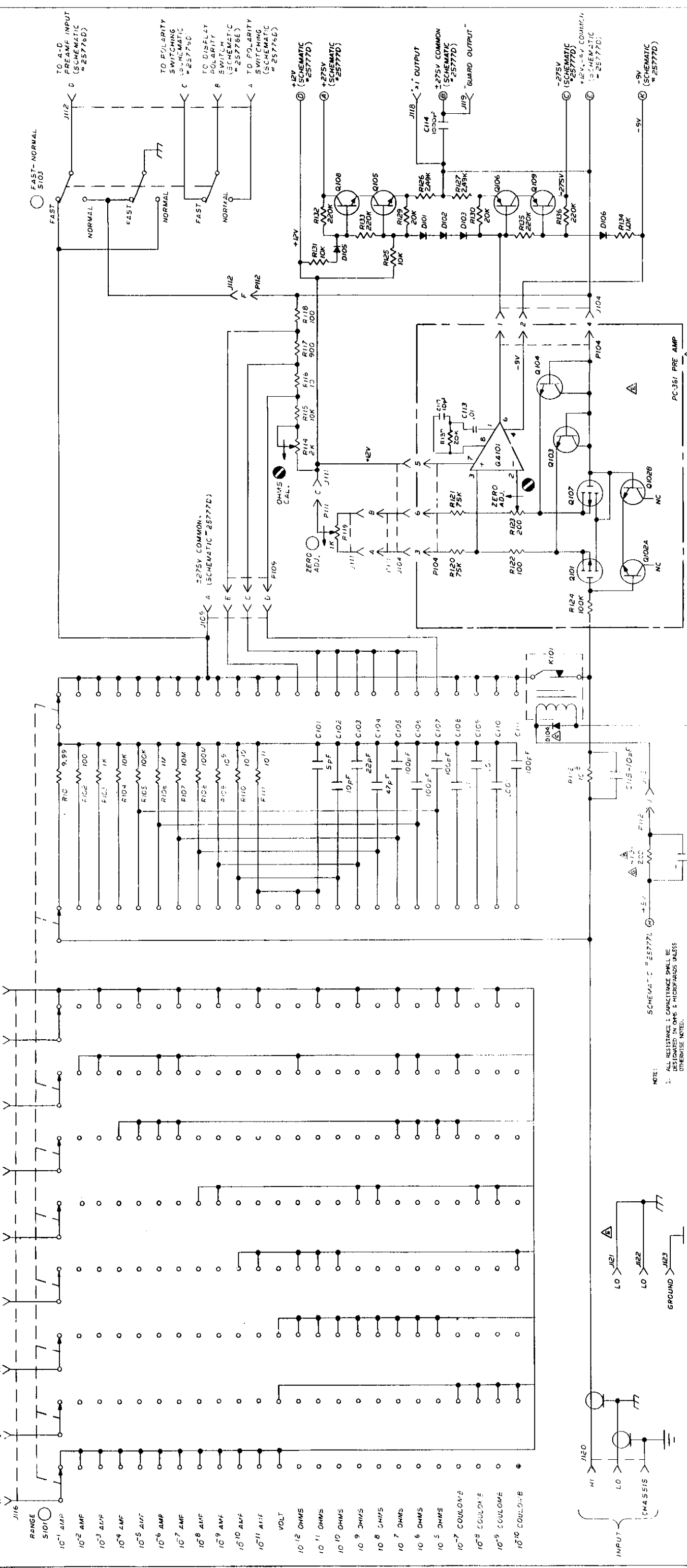

Figure 39. Component Layout, PC-602

REV	NO	DATE	DESCRIPTION
A	1	7-13-57	REVISED
B	2	7-13-57	REVISED
C	3	7-13-57	REVISED
D	4	7-13-57	REVISED
E	5	7-13-57	REVISED
F	6	7-13-57	REVISED
G	7	7-13-57	REVISED
H	8	7-13-57	REVISED
I	9	7-13-57	REVISED
J	10	7-13-57	REVISED
K	11	7-13-57	REVISED
L	12	7-13-57	REVISED
M	13	7-13-57	REVISED
N	14	7-13-57	REVISED

M



TO MODEL 6162

- NOTE:
1. ALL RESISTANCE & CAPACITANCE SHALL BE DESIGNATED IN OHMS & MICROFARADS UNLESS OTHERWISE NOTED.
 2. FRONT PANEL CONTROL.
 3. INTERNAL SPREADSWITCH ADJ.
 4. H HEDON & 1000 OHMS PF POTENTIOMETER.
 5. CLOCKWISE ROTATION.
 6. POWER SUPPLY GND.
 7. CHASSIS GND.

SCHEMATIC DESIGNATIONS	
NOT USED	USED
R137	Q109
C117	K101
D106	S103
G101	J123

HIGHEST SCHEMATIC DESIGNATIONS USED	
R137	Q109
C117	K101
D106	S103
G101	J123

PC-361 PRE AMP

ZERO CHECK

ZERO G-ECK

TO A-D PREAMP INPUT (SCHEMATIC # 25777D)

TO POLARITY SWITCHING (SCHEMATIC # 25775D)

TO POLARITY SWITCHING (SCHEMATIC # 25776E)

TO POLARITY SWITCHING (SCHEMATIC # 25777D)

TO POLARITY SWITCHING (SCHEMATIC # 25777D)

TO POLARITY SWITCHING (SCHEMATIC # 25777D)

TO POLARITY SWITCHING (SCHEMATIC # 25777D)

TO POLARITY SWITCHING (SCHEMATIC # 25777D)

TO POLARITY SWITCHING (SCHEMATIC # 25777D)

TO POLARITY SWITCHING (SCHEMATIC # 25777D)

TO POLARITY SWITCHING (SCHEMATIC # 25777D)

TO POLARITY SWITCHING (SCHEMATIC # 25777D)

DO NOT SCALE THIS DRAWING
 DRAWING NUMBER: 6162-1
 DATE: 7-13-57
 DRAWN BY: J. G. S. / J. G. S.
 CHECKED BY: J. G. S. / J. G. S.
 INSTRUMENTS: ELECTRONIC
 MATERIAL: WIRE, FUSES, TRANSISTORS, CAPACITORS, RESISTORS
 SURFACE: GND

25764E



KEITHLEY INSTRUMENTS, INC.

Page 1 of 1
0773

INSTRUCTION MANUAL
CHANGE NOTICE
MODEL 616 DIGITAL ELECTROMETER

INTRODUCTION: Since Keithley Instruments is continually improving product performance and reliability, it is often necessary to make changes to Instruction Manuals to reflect these improvements. Also, errors in Instruction Manuals occasionally occur that require changes. Sometimes, due to printing lead time and shipping requirements, we can't get these changes immediately into printed Manuals. The following new change information is supplied as a supplement to this Manual in order to provide the user with the latest improvements and corrections in the shortest possible time. Many users will transfer this change information directly to a Manual to minimize user error. All changes or additions are indicated in *italics*.

CHANGES:

Page iv: Specifications. ISOLATION: Circuit Lo to chassis ground; *greater than 10^9 ohms* shunted by 500 picofarads (*decreasing to 10^8 ohms* at 30°C and 70% relative humidity).