



Advanced Test Equipment Rentals
www.atecorp.com 800-404-ATEC (2832)

Service Manual

HP 8595A Portable Spectrum Analyzer



HP Part No. 08595-90001 Microfiche Part No. 08595-90002
Printed in USA March 1991

©Copyright Hewlett-Packard Company 1991
All Rights Reserved. Reproduction, adaptation, or translation without prior written
permission is prohibited, except as allowed under the copyright laws.
1212 Valley House Drive, Rohnert Park, CA 94928-4999, USA

Safety Symbols

The following safety symbols are used throughout this manual. Familiarize yourself with each of the symbols and its meaning before operating this instrument.

Caution



The *caution* sign denotes a hazard. It calls attention to a procedure which, if not correctly performed or adhered to, could result in damage to or destruction of the instrument. Do not proceed beyond a *caution* sign until the indicated conditions are fully understood and met.

Warning



The *warning* sign denotes a hazard. It calls attention to a procedure which, if not correctly performed or adhered to, could result in injury or loss of life. Do not proceed beyond a *warning* sign until the indicated conditions are fully understood and met.

General Safety Considerations

Warning



Before this instrument is switched on, make sure it has been properly grounded through the protective conductor of the ac power cable to a socket outlet provided with protective earth contact.

Any interruption of the protective (grounding) conductor, inside or outside the instrument, or disconnection of the protective earth terminal can result in personal injury.

Warning



There are many points in the instrument which can, if contacted, cause personal injury. Be extremely careful.

Any adjustments or service procedures that require operation of the instrument with protective covers removed should be performed only by trained service personnel.

Caution



Before this instrument is switched on, make sure its primary power circuitry has been adapted to the voltage of the ac power source.

Failure to set the ac power input to the correct voltage could cause damage to the instrument when the ac power cable is plugged in.

HP 8590 Series Spectrum Analyzer Documentation Description

Manuals Shipped with Your Spectrum Analyzer

Installation and Verification Manual

Describes how to install the spectrum analyzer.
Tells how to make measurements with your spectrum analyzer.
Details what to do in case of a failure.

HP 8590 Series Operating Manual

Tells how to make measurements with your spectrum analyzer.
Describes analyzer features.
Describes common applications.

HP 8590 Series Quick Reference Guide

Describes how to make a simple measurement with your spectrum analyzer.
Briefly describes the spectrum analyzer functions.
Lists all the programming commands.

Options

Option 910: Installation and Verification Manual, Operating Manual and Quick Reference Guide

Provides an additional copy of the installation and verification manual, the operating manual, and the quick reference guide.

Option 915: Service Manual (Model Specific) and Component-Level Information

Describes troubleshooting and repair of the spectrum analyzer.

Option 915 consists of two manuals:

Service manual describes assembly level repair of the analyzer.

HP 8590B/91A/92B/93A/94A/95A Component-Level Information provides information for component-level repair of the spectrum analyzer.

Options 021 and 023: HP 8590 Series Programming Manual

The *HP 8590 Series Spectrum Analyzer Programming Manual* describes analyzer operation via a remote controller (computer) for Options 021 and 023. This manual is provided when ordering either Option 021 or Option 023.

How to Order Manuals

Each of the manuals listed above can be ordered individually. To order, contact your local HP Sales and Service Office.

How to Use This Manual

Where to Start

If you have just received the HP 8591A or HP 8593A and want to get it ready for use for the first time:

1. Skim Chapter 1, "Introducing the Spectrum Analyzer," for a brief introduction to the unit and its capabilities.
2. Thoroughly read Chapter 2, "Installation and Preparation for Use," and follow its instructions for:
 - a. Unpacking the unit.
 - b. Preparing it for use.
 - c. Performing initial self-calibration routines (these are automatic self-checks and require no test equipment).
3. If you need to verify the unit is operating within its specifications, perform the verification tests in Chapter 3 (for the HP 8591A) or Chapter 4 (for the HP 8593A).

After completing performance verification, use the HP 8590 Series Operating Manual to learn how to use the analyzer and to find more detailed information about the analyzer, its applications, and key descriptions.

If the Analyzer Has Been in Use

To verify that it is operating correctly or to solve an apparent problem:

- Perform the calibration routines given in Chapter 2, "Installation and Preparation for Use," for a quick indication of proper operation.
- If you have the necessary test equipment, perform the verification tests in Chapter 3 or Chapter 4 to verify that the unit is operating within its specifications.
- If there is an apparent problem, read Chapter 5, "Problems," for hints on what may be wrong and how to solve the problem, and instructions for calling Hewlett-Packard for additional help.

Manual Terms and Conventions

Front-panel keys appear within a box, for example, **FREQUENCY**. Softkeys appear within a shaded box, for example, **CENTER FREQ.**

Contents

1. General Information	
Introduction	1-1
Manual Organization	1-2
Spectrum Analyzer Description	1-3
Serial-Number Label	1-4
Serial Number Description	1-4
Option Number	1-4
Firmware Revision Date	1-5
Firmware Upgrade Kit Ordering Information	1-5
Safety Considerations	1-6
Reliability Considerations	1-7
Spectrum-Analyzer Input Protection	1-7
Protection from Electrostatic Discharge	1-7
Handling of Electronic Components and ESD	1-8
Test Equipment Usage and ESD	1-8
For Additional Information about ESD	1-9
Returning Instruments for Service	1-10
Sales and Service Offices	1-13
Recommended Test Equipment	1-13
Recommended Service Tools	1-13
2. Adjustment Procedures	
Before You Start	2-1
Contents	2-2
Recommended Test Equipment	2-3
Abnormal Indications During Adjustment	2-3
Periodically Verifying Calibration	2-3
Standard-Value Replacement Components	2-3
1. Power Supply	2-9
2. Display	2-11
3. Sampler Match	2-16
4. 10 MHz Reference (Standard)	2-18
5. 10 MHz Reference Adjustment (Option 004)	2-20
6. Crystal and LC Bandwidth Filter	2-23
7. Cal Attenuator Error Correction	2-31
8. Log and Linear Amplifier	2-35
9. CAL FREQ Adjustment Routine	2-39
10. CAL AMPTD Adjustment Routine	2-41
11. CAL YTF Adjustment Routine	2-43
12. CAL MXR Adjustment Routine	2-46
13. Third Converter and Second IF Bandpass	2-48
14. Comb Generator	2-53

15. Frequency Response	2-57
16. Time and Date	2-65
17. First LO Distribution Amplifier Adjustment (Option 009, 010)	2-66
18. BITG Power Level Adjustments (Option 010)	2-68
19. Tracking Oscillator Adjustment (Option 010)	2-71
3. Replacement Procedures	
Introduction	3-1
Before You Start	3-1
Removal and Replacement Procedures in this Chapter	3-2
Instrument Cover	3-3
A1 Front-Frame Assembly	3-4
A1A1 Keyboard/Front-Panel Keys	3-7
A2 Display	3-9
Before Replacing the A3 Front-End Assembly	3-13
A3A3 Low-Pass and A3A9 Bandpass Filters	3-16
A3 Front-End Assembly	3-18
FL1 Low-Pass Filter	3-24
A3A15 Tracking Generator (Option 010)	3-27
A3A1 Comb Generator	3-30
A3A4 Second Converter	3-32
A3A5 Attenuator/DC Block	3-35
A3A2 Switched YTF	3-38
A3A7 YTO	3-44
A3A6 Dual Mixer	3-48
A3A14 First LO Distribution Amplifier (Option 009, 010)	3-54
A3A13 Isolator	3-56
A3A10 Directional Coupler	3-59
A7 Analog Interface Assembly	3-66
A8 Power Supply	3-70
A15 Motherboard and IF Extrusion	3-72
A16 Processor/Video Board Assembly	3-81
A16 Processor/Video Board Firmware ROMs	3-86
A17 Memory Card Reader Assembly	3-89
B1 Fan	3-91
BT101 Battery	3-93
Rear-Frame Assembly	3-95
4. Replaceable Parts	
Introduction	4-1
Assembly-Level Replaceable Parts Table Format	4-1
Parts Identification Format	4-2
Ordering Information	4-2
Direct Mail-Order System	4-2
Direct Phone-Order System	4-3
Regular Orders	4-3
Hotline Orders	4-3

5. Major Assembly and Cable Locations	
Introduction	5-1
Contents	5-1
6. General Troubleshooting	
Introduction	6-1
Before You Start Troubleshooting	6-1
Chapter Organization	6-2
Chapter 6, "General Troubleshooting"	6-2
Chapter 7, "RF/LO Section Troubleshooting"	6-3
Chapter 8, "IF Section Troubleshooting"	6-3
Chapter 9, "Control/Display Section Troubleshooting"	6-3
Chapter 10, "Softkey Descriptions"	6-3
Chapter 11, "Analyzer Messages"	6-4
Service Equipment	6-4
Replacement Assemblies	6-4
After an Instrument Repair	6-4
RF and LO Section Overview	6-13
RF Section Description	6-13
A3A5 Input Attenuator DC Block	6-13
A3A2 Switched YTF	6-13
A3A3 Low-Pass Filter	6-14
A3A6 Dual-Band Mixer	6-14
A3A4 Second Converter	6-14
A9 Third Converter	6-15
A3A1 Comb Generator	6-15
The A3A11 Step-Recovery Diode and the A3A12 3 dB Pad	6-15
LO Section Description	6-16
10 MHz Frequency Reference	6-16
A25 Counter Lock	6-16
A25A1 Sampler	6-16
A3A7 YTO, A3A13 Isolator, and A3A10 Directional Coupler	6-17
A7 Analog Interface	6-17
Instrument Settings for RF Power-Level Measurement	6-18
IF, Video, and Instrument Control Overview	6-19
IF Section Assembly Descriptions	6-19
A11 Bandwidth Filter	6-19
A12 Amplitude Control	6-19
A13 Bandwidth Filter	6-20
A14 Log Amplifier	6-20
A16 Processor/Video	6-20
A7 Analog Interface	6-21
A8 Power Supply	6-22
IF Power-Level Measurement	6-23
Instrument Settings for IF Power-Level Measurement	6-23
Typical Gains for the IF Assemblies	6-23
Measurement of the IF Signal from the A9 Third Converter	6-24
Signal Injection at the Output of the A11 Bandwidth Filter Assembly	6-24
Signal Injection at the Output of the A13 Bandwidth Filter Assembly	6-25
Problems at Instrument Power-Up	6-25
Symptoms at Power-Up	6-26

Troubleshooting an Inoperative Spectrum Analyzer	6-28
Check Instrument Setup	6-28
Instrument Failure Symptoms	6-28
The Line Fuse Has Blown	6-29
The Fan Is Not Operating	6-29
A8 Power Supply LEDs Are Off	6-30
If All the A8 LEDs are Off	6-30
If Individual A8 LEDs are Off	6-32
A16 Processor/Video Assembly Failure Symptoms	6-32
Blank A2 Display	6-32
A2 Display Troubleshooting	6-33
If the Display has an Intensity Problem	6-33
Check the A16 Display-Drive Circuitry	6-33
Check High-Power-Up Signal from the A8 Power Supply	6-34
Check for a Defective A2 Display	6-36
Symptoms of a Dead Battery	6-37
If a Random Display Periodically Flashes on Screen	6-37
If the Error Message FAIL: 0330 0000000000 Appears	6-37
Verify that the Correction Data is Missing	6-38
After Replacing the Battery	6-38
Instrument Recalibration after a Battery-Backed RAM Memory Loss	6-39
Locating an RF/LO/IF or Video Problem	6-40
Techniques for Isolating an RF/LO/IF or Video Failure	6-40
RF/LO/IF and Video Failure Symptoms	6-41
7. RF/LO Section Troubleshooting	
Introduction	7-1
Before You Start Troubleshooting	7-1
RF Section Information	7-2
RF Section Operation	7-2
Control of the A3A5 Input Attenuator	7-3
LO Section Information	7-4
A9 Third Converter Assembly	7-6
A25 Counter Lock Assembly	7-8
A3A15 Tracking Generator	7-9
Description	7-9
Tracking Oscillator	7-9
Upconverter	7-9
Pentupler	7-9
Modulator	7-9
Coupler	7-9
Output Mixer	7-10
Output Amplifier	7-10
Bias Board	7-10
Tracking Generator Troubleshooting	7-10
Output Goes Uneveled (TG UNLVL Message Displayed)	7-10
Excessive Residual FM	7-11
Flatness Out of Tolerance	7-12
Vernier Accuracy Out of Tolerance	7-13
Harmonic/Spurious Outputs Too High	7-13
Power Sweep Not Functioning Properly	7-14

No Power Output	7-15
A3A14 First LO Distribution Amplifier (LODA)	7-16
Description	7-16
First LO Distribution Amplifier Troubleshooting	7-16
8. IF Section Troubleshooting	
Introduction	8-1
Before You Start Troubleshooting	8-1
IF Section Information	8-2
Bandwidth Control Lines for the A11/A13 Bandwidth Filter Assemblies	8-2
IF Section Gain Control	8-3
Control Lines for the A12 Amplitude Control Assembly	8-5
Linear Gain Control Lines for A14 Log Amplifier	8-6
A15 Motherboard Assembly	8-7
9. Control/Display Section Troubleshooting	
Introduction	9-1
Before You Start Troubleshooting	9-1
Backing Up Spectrum Analyzer Correction Constants	9-2
Retrieving the Timebase and Flatness-Correction Constants	9-2
Retrieving the A12 Step-Gain-Correction Constants	9-3
A16 Memory Reset	9-6
Performing an A16 Memory Reset	9-6
Instrument Response after Memory Reset	9-7
Spectrum Analyzer Recovery after a A16 Memory Loss	9-8
Resetting the Spectrum Analyzer Power-On Units	9-9
Reloading the Timebase and Flatness Correction Constants	9-9
Reloading the A12 Step-Gain-Correction Constants	9-11
Instrument Recalibration after Reloading the Correction Constants	9-11
A7 Analog Interface Assembly	9-13
10. Softkey Descriptions	
Introduction	10-1
Calibration, Service, and Diagnostic Softkey Functions	10-1
[CAL] Softkey Organization	10-1
Passcodes	10-3
Entering A Passcode	10-3
Understanding Instrument Correction Data	10-4
Self-Calibration Correction Factors	10-4
Service-Calibration Correction Constants	10-4
+10 V REF DETECTOR +10 V Reference Detector	10-6
-10 V REF DETECTOR -10 V Reference Detector	10-6
2V REF DETECTOR 2 V Reference Detector	10-6
AUXA Auxiliary A	10-7
[CAL] Calibration Key	10-7
CAL AMPTD Calibrate Amplitude	10-7
CAL FETCH Calibration Fetch	10-9
CAL FREQ Calibrate Frequency	10-10
CAL FREQ & AMPTD Calibrate Frequency and Amplitude	10-12

CAL MIX Calibrate Mixer	10-12
CAL STORE Calibration Store	10-13
CAL TIMEBASE Calibrate Timebase	10-14
CAL YTF Calibrate YTF	10-14
COARSE TUNE DAC Coarse Tune DAC	10-15
CONF TEST Confidence Test	10-16
CORRECT ON OFF Correction On/Off	10-17
CRT HORZ POSITION CRT Horizontal Position	10-19
CRT VERT POSITION CRT Vertical Position	10-19
DACS DACs	10-19
DEFAULT CAL DATA Default Calibration Data	10-21
DISPLAY CAL DATA Display Calibration Data	10-23
DROOP Droop	10-25
EDIT FLATNESS Edit Flatness	10-26
EXECUTE TITLE Execute Title	10-27
EXIT Exit	10-27
FINE TUNE DAC Fine Tune DAC	10-27
FLATNESS DATA Flatness Data	10-28
FM COIL DRIVE FM Coil Drive	10-28
FM GAIN FM Gain	10-29
FM OFFSET FM Offset	10-30
FM SPAN FM Span	10-31
FREQ DIAG Frequency Diagnostics	10-32
FRQ DISC NORM OFF Frequency Discriminator Normal/Off	10-33
GND REF DETECTOR Ground-Reference Detector	10-33
IDNUM Identification Number	10-33
INIT FLT Initialize Flatness	10-34
MAIN COIL DR Main-Coil Drive	10-35
MAIN SPAN Main Span	10-35
MIXER BIAS DAC Mixer-Bias DAC	10-36
PRESEL DAC Preselector DAC	10-36
QP DET ON OFF Quasi-Peak Detector On/Off	10-37
QP GAIN ON OFF Quasi-Peak GAIN On/Off	10-37
QPD OFFSET Quasi-Peak Detector Offset	10-37
QPD RST ON OFF Quasi-Peak Detector Reset On/Off	10-38
SERVICE CAL Service Calibration	10-38
SERVICE DIAG Service Diagnostics	10-38
SET ATTN ERROR Set Attenuator Error	10-38
SETPLL OUTDAC Set PLL Out DAC	10-40
STOR PWR ON UNITS Store Power-On Units	10-40

STORE FLATNESS Store Flatness	10-41
STP GAIN ZERO Step-Gain Zero	10-41
SWEEP RAMP Sweep Ramp	10-41
SWEEP TIME DAC Sweep-Time DAC	10-42
VERIFY TIMEBASE Verify Timebase	10-42
X FINE TUNE DAC Extra-Fine Tune DAC	10-43
YTF DRIVER YTF Driver	10-43
YTF TUNE COARSE YTF Tune Coarse	10-44
YTF TUNE FINE YTF Tune Fine	10-44
YTF SPAN YTF Span	10-45

11. Analyzer Messages	
Introduction	11-1
Interpreting Analyzer Messages	11-1
Chapter Organization	11-1
ADC-GND FAIL (H)	11-2
ADC-TIME FAIL (H)	11-4
ADC-2V FAIL (H)	11-4
CAL: - - - (M)	11-6
CAL: DATA NOT STORED CAL AMP NEEDED (U)(H)	11-6
CAL: cannot execute CALAMP enter: 0 dB PREAMP GAIN (U)(H)	11-7
CAL: FM SPAN SENS FAIL (H)	11-7
CAL: GAIN FAIL (H)	11-8
CAL: LOST COMB SIGNAL (U)(H)	11-9
CAL: PASSCODE NEEDED (M)	11-9
CAL: RES BW AMPL FAIL (H)	11-9
CAL SIGNAL NOT FOUND (U)(H)	11-10
CAL: SPAN SENS FAIL (H)	11-11
CAL: USING DEFAULT DATA (M)	11-11
COMB SIGNAL NOT FOUND (U)(H)	11-11
CONF TEST FAIL (H)	11-12
FAIL: XXXX XXXXXXXXXXXX (H)	11-12
The Four-Digit Failure Code	11-13
The 10-Digit Failure Code	11-13
FREQ UNCAL (U) (H)	11-16
INVALID FLATNESS DATA (U)	11-16
MIXER BIAS CAL FAILED	11-17
OVEN COLD (M)	11-18
POS-PK FAIL (H)	11-18
RES-BW SHAPE FAIL (H)	11-19
RES-BW NOISE FAIL (H)	11-20
REF UNLOCK (M)(H)	11-20
SAMPLE FAIL (H)	11-21
STEP GAIN/ATTEN FAIL (H)	11-22
SRQ - - - (M)	11-22
VID-BW FAIL (H)	11-23

A. Component-Level Information Packets
Ordering CLIPs

A-1

Figures

1-1. HP 8595A Spectrum Analyzer	1-1
1-2. Typical Serial-Number Label	1-4
1-3. Example of a Static-Safe Work Station	1-8
1-4. Instrument Packaging Material	1-12
1-5. Special Service Tools	1-21
2-1. A16 Power Supply Test Point Location	2-9
2-2. Power Supply Adjustment Location	2-10
2-3. Fine Focus Adjustment Location	2-12
2-4. Coarse Focus Adjustment Location	2-14
2-5. Coarse Focus Adjustment Location (Rear View of Display Assembly)	2-15
2-6. A25 Counter Lock Assembly Test Points	2-17
2-7. 10 MHz Reference Adjustment Setup	2-18
2-8. Precision Frequency Reference Setup	2-21
2-9. Oven Reference Adjustment Location	2-22
2-10. Crystal Symmetry and Centering	2-24
2-11. LC Dip Location	2-26
2-12. Displayed Calibration Data	2-29
2-13. Cal Attenuator Error Correction Setup	2-31
2-14. Log and Linear Amplifier Adjustment Setup	2-36
2-15. Log and Linear Amplifier Adjustment Location	2-37
2-16. CAL FREQ Adjustment Routine Setup	2-39
2-17. CAL AMPTD Adjustment Routine Setup	2-41
2-18. CAL YTF Adjustment Setup	2-43
2-19. CAL MXR Adjustment Setup	2-46
2-20. Second IF Bandpass Filter Adjustment Setup	2-49
2-21. LPF Characterization	2-50
2-22. 300 MHz Calibrator Amplitude Accuracy Test Setup	2-51
2-23. Comb Generator Adjustment Location	2-54
2-24. Comb Generator Component Location	2-55
2-25. Frequency Response Setup	2-58
2-26. First LO Distribution Amplifier Adjustment Setup	2-67
2-27. BITG Power Level Adjustment Setup	2-69
2-28. BITG Power Level Adjustment Locations	2-69
2-29. Frequency Tracking Range Setup	2-72
2-30. Tracking Oscillator Adjustment Setup	2-73
3-1. A1 Front-Frame Replacement	3-5
3-2. A1A1 Front-Panel Key Positions	3-8
3-3. A2 Display Replacement	3-10
3-4. A2 Display, Rear View	3-11
3-5. A3 Front-End Assembly Order of Removal	3-14
3-6. A3 Front-End Bracket Assembly	3-15
3-7. A3A3 and A3A9 Filter Replacement	3-17

3-8. A3 Front-End Replacement, Bottom View	3-19
3-9. A3 Front-End Replacement, Top View	3-21
3-10. FL1 Filter Replacement	3-25
3-11. A3A15 Tracking Generator Replacement	3-28
3-12. A3A1 Comb Generator Replacement	3-31
3-13. A3A4 Second Converter Replacement	3-33
3-14. A3A5 Attenuator Replacement	3-36
3-15. A3A2 Switched YTF Replacement	3-39
3-16. A3A2 Switched YTF Wiring Replacement	3-42
3-17. A3A7 YTO Replacement	3-45
3-18. A3A7 YTO and YTO Enclosure	3-46
3-19. A3A6 Dual Mixer Replacement, Right-Side View	3-49
3-20. A3A6 Dual Mixer Replacement, Right and Left-Side Views	3-51
3-21. A3A14 First LO Distribution Amplifier Replacement	3-55
3-22. A3A13 Isolator Replacement	3-57
3-23. A3A10 Directional Coupler Replacement, Right-Side View	3-60
3-24. A3A10 Directional Coupler Replacement, Left-Side View	3-61
3-25. A3A10 Directional Coupler Replacement, Front and Right-Side Views	3-63
3-26. A7 Analog Interface Assembly Replacement	3-67
3-27. End View of Connectors for W12, W35, and W36	3-68
3-28. A8 Power Supply Replacement	3-71
3-29. A15 Motherboard Replacement	3-73
3-30. A15 Motherboard with IF Section	3-75
3-31. IF Extrusion Assembly Replacement	3-76
3-32. IF Extrusion Section Replacement	3-77
3-33. Connector Key Position on W12, W35, and W36	3-79
3-34. A16 Processor/Video Board Replacement	3-83
3-35. A16 Processor/Video Board Firmware ROM Replacement	3-87
3-36. A17 Memory Card Reader Replacement	3-90
3-37. B1 Fan Replacement	3-91
3-38. BT101 Battery Replacement	3-93
4-1. Spectrum Analyzer Parts Identification, Handle Assembly	4-12
4-2. Spectrum Analyzer Parts Identification, Cover Assembly	4-13
4-3. Spectrum Analyzer Parts Identification, Front Frame Assy	4-14
4-4. Spectrum Analyzer Parts Identification, Front Frame Assy	4-15
4-5. Spectrum Analyzer Parts Identification, Rear Frame Assembly	4-17
4-6. Spectrum Analyzer Parts Identification, IF Assembly	4-18
4-7. Spectrum Analyzer Parts Identification, Miscellaneous Chassis	4-19
4-8. Spectrum Analyzer Parts Identification, Miscellaneous Chassis	4-20
4-9. Spectrum Analyzer Parts Identification, Miscellaneous Chassis	4-21
4-10. Spectrum Analyzer Parts Identification, Front-End Bracket Assembly	4-23
4-11. Spectrum Analyzer Parts Identification, Front-End Right-Side View	4-24
4-12. Spectrum Analyzer Parts Identification, Front-End Left-Side View	4-26
4-13. Spectrum Analyzer Parts Identification, Impact Cover	4-27
5-1. HP 8595A A1 Front-Frame Assembly, Front and Rear Views	5-3
5-2. HP 8595A Top View	5-4
5-3. HP 8595A Card-Cage Options, Top View (Options 101, 102, 301)	5-5
5-4. HP 8595A Card-Cage Options, Top View (Options 009, 010)	5-6
5-5. HP 8595A Card-Cage Options, Top View (Options 103)	5-7
5-6. HP 8595A Bottom View	5-8
5-7. HP 8595A Options, Bottom View	5-9

5-8. HP 8595A A3 Front-End Assembly, Top and Left-Side Views	5-10
5-9. HP 8595A A3 Front-End Assembly, Right-Side View	5-11
5-10. HP 8595A A3 Front-End Assembly, Rear View with A3A5 Removed	5-12
5-11. HP 8595A A3 Front-End Assembly, Right-Side View (Option 009, 010)	5-13
5-12. HP 8595A A3 Front-End Assembly, Rear View with A3A5 Removed (Option 009, 010)	5-14
6-1. Graphics Symbols Used on Schematic and Block Diagrams	6-11
6-2. A15J13 Connector-Pin Designation	6-31
6-3. A16J8 Display Signal Output Pins	6-34
6-4. A16J1 Connector-Pin Orientation	6-35
6-5. Card-Cage Connector-Pin Orientation	6-36
F/O 6-1. HP 8595A RF Section, Overall Block Diagram	
F/O 6-2. HP 8595A IF/Control Overall, Block Diagram	
F/O 7-1. HP 8595A RF Section Block Diagram	
F/O 7-2. HP 8595A LO Section, Block Diagram	
F/O 7-3. HP 8595A A9 Third Converter Assembly, Block Diagram	
F/O 7-4. HP 8595A A25 Counter Lock Assembly, Block Diagram	
F/O 7-5. HP 8595A A10 Tracking Generator Control Block Diagram	
F/O 7-6. HP 8595A AM/FM DEMOD TV Trigger Block Diagram	
F/O 7-7. HP 8595A AM/FM DEMOD Quasi Peak Detector Block Diagram	
8-1. A15 Motherboard Connector Designation	8-8
8-2. A15 Connectors with Additional Associated Circuitry	8-9
8-3. A15J13 Connector-Pin Designation	8-11
8-4. Card-Cage Connector Pin Designation	8-12
9-1. Location of U104 on the A16 Assembly	9-7
F/O 9-1. HP 8595A A7 Analog Interface Assembly, Block Diagram	
10-1. Calibration, Service, and Diagnostic Softkey Tree	10-2
10-2. Default Calibration Data	10-21
10-3. Calibration Data Map	10-23
10-4. LO Frequency Diagnostic Data Display	10-32
11-1. A16J1 Connector-Pin Orientation	11-3
11-2. A16J1 Connector-Pin Orientation	11-5

Tables

1-1. HP 8595A Maximum Safe Input Level	1-7
1-2. Static-Safe Accessories	1-9
1-3. Hewlett-Packard Sales and Service Offices	1-14
1-4. Recommended Test Equipment	1-15
1-5. Special Service Tools	1-20
1-6. Required Common Hand Tools	1-22
2-1. HP 8595A Spectrum Analyzer Adjustments	2-2
2-2. Standard Value Replacement Capacitors	2-4
2-3. Standard Value Replacement Resistors, 0.125 W	2-5
2-4. Standard Value Replacement Resistors, 0.5 W	2-7
2-5. Power Supply Tolerances	2-10
2-6. Bandwidth Amplitude-Correction Map	2-29
2-7. A12 Amplitude Control Assembly Attenuator Errors	2-33
2-8. Log Fidelity Check	2-38
2-9. Linear Gain Check	2-38
2-10. Acceptable Mixer Bias DAC Correction Values	2-44
2-11. Frequency Response Errors Band 0	2-62
2-12. Frequency Response Errors Band 1	2-64
2-13. Tracking Oscillator Range Centering	2-75
4-1. Reference Designations, Abbreviations and Multipliers	4-4
4-2. HP 8595A Assembly-Level Replaceable Parts	4-8
4-3. Firmware History	4-11
6-1. Assembly-to-Functional-Block Matrix	6-5
6-2. Adjustments and Tests for Replaced or Repaired Assemblies	6-6
6-3. Relationship of Input Frequency to LO Harmonic	6-14
6-4. Power Levels at Measurement Points	6-18
6-5. Instrument Failure Symptoms at Power-On	6-27
7-1. Input Attenuator Control Output at A7J5	7-3
8-1. Nominal Resolution Bandwidth Control Line Voltages	8-2
8-2. IF Section Gain Table in dB	8-4
8-3. 10 dB Step-Gain Control Lines	8-5
8-4. Calibration-Attenuator Control Lines	8-5
8-5. Linear Gain Control Lines on the A14 Assembly	8-6
8-6. A15 Motherboard Mnemonic Descriptions	8-13
8-7. A15 Motherboard Pin Designations	8-17
9-1. RTXO Timebase Correction Constant (Instruments without Option 004)	9-4
9-2. Frequency-Response Correction Constants—Band 0	9-4
9-3. Frequency-Response Correction Constants—Band 1	9-5
9-4. A12 Step-Attenuator Correction Constants	9-5
11-1. Possible Cause of the Error Message “ADC-GND FAIL”	11-3
11-2. Possible Cause of the Error Message “ADC-2V FAIL”	11-5
11-3. Four-Digit Failure Code Interpretation	11-13
11-4. I/O Bus Address Failure-Code Interpretation	11-14

11-5. I/O Data Bus Failure Code Interpretation	11-14
11-6. A16 Video Ram Address Failure Code Interpretation	11-15
A-1. HP 8595A Spectrum Analyzer Board Assembly, Serial Number, and CLIP Part Number Cross-Reference	A-2

General Information

Introduction

The *HP 8595A Portable Spectrum Analyzer Service Manual* provides the information needed to adjust and repair the HP 8595A Portable Spectrum Analyzer to the assembly level.

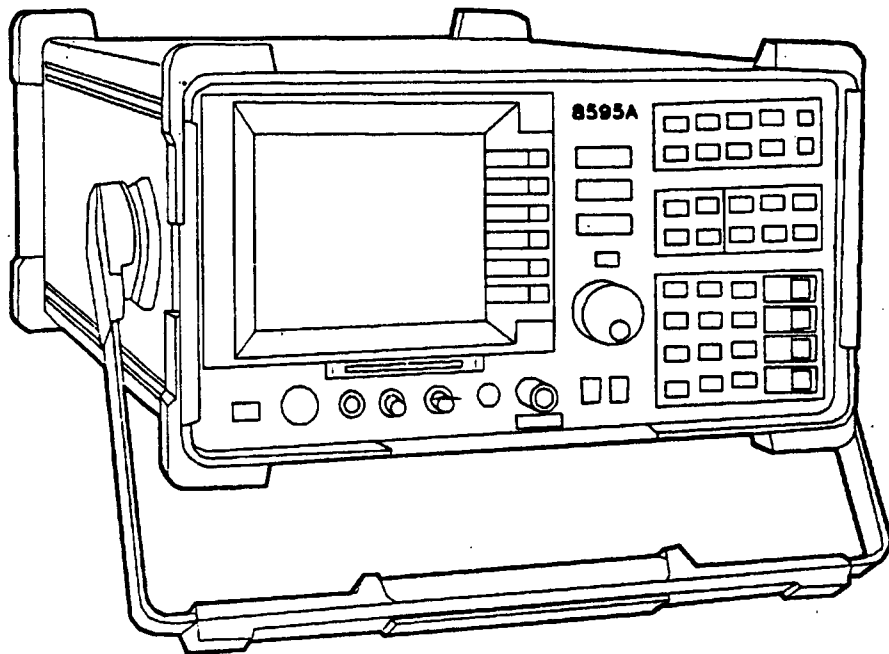

Figure 1-1. HP 8595A Spectrum Analyzer

The *HP 8590 Series Component-Level Information* binder provides component-level information for the repair of individual instrument assemblies. The binder contains Component-Level Information Packets (CLIPs) for selected assemblies. Each CLIP contains component-level schematics, a component parts list, and illustrations for component location by reference designator. Each CLIP has its own HP part number, which is changed whenever the HP part number for its related instrument assembly is changed. A list of all CLIP part numbers for the HP 8595A is provided in the appendix of this service manual.

Manual Organization

The manual is divided into the following chapters:

- Chapter 1, "General Information," contains information on spectrum-analyzer identification, safety considerations, return of an instrument for service, and recommended test equipment.
- Chapter 2, "Adjustments," contains the adjustment procedures needed to adjust the spectrum analyzer to meet its specifications.
- Chapter 3, "Replacement Procedures," contains instructions for the removal and replacement of all major assemblies.
- Chapter 4, "Replaceable Parts," contains information needed to order assemblies for the spectrum analyzer.
- Chapter 5, "Major Assembly and Cable Locations," contains figures identifying all major assemblies and cables.
- Chapter 6, "General Troubleshooting," contains a description of overall spectrum-analyzer operation and troubleshooting procedures that are useful when first troubleshooting a spectrum analyzer failure.
- Chapter 7, "RF/LO Section Troubleshooting," contains specific troubleshooting information for selected assemblies within the RF and LO sections.
- Chapter 8, "IF Section Troubleshooting," contains specific troubleshooting information for selected assemblies in the IF section and the A15 Motherboard assembly.
- Chapter 9, "Control/Display Section Troubleshooting," contains troubleshooting information for the A7 Analog Interface and A16 Processor/Video assemblies. Procedures for resetting spectrum analyzer memory are also provided.
- Chapter 10, "Softkey Descriptions," contains a description of the calibration, service, and diagnostic softkeys.
- Chapter 11, "Analyzer Messages," contains a description of the spectrum analyzer messages that are displayed when there is a problem with the spectrum analyzer.
- Appendixes, "Appendix A," contains a list of the HP part numbers for all the Component-Level Information packets (CLIPs) that are available for the HP 8595A.

Spectrum Analyzer Description

The HP 8590 series of portable spectrum analyzers provide measurement capabilities over the RF and microwave frequency ranges.

The standard HP 8595A Portable Spectrum Analyzer covers a frequency range of 9 kHz to 6.5 GHz with synthesizer-like frequency accuracy.

A memory card reader allows the analyzer to use downloadable software programs. The functional "personality" of the HP 8595A can also be altered using the memory card reader. This feature provides the user with one instrument that can perform the function of other types of microwave test equipment. The following options may be installed in the HP 8595A Spectrum Analyzer:

Option 004, precision frequency reference, provides a precision 10 MHz reference output at the rear frame.

Option 021, HP-IB, allows the HP 8595A Spectrum Analyzer to be controlled by a computer via HP-IB. An input connector for an external keyboard is also provided.

Option 023, RS-232, allows the HP 8595A Spectrum Analyzer to be controlled by a computer via an RS-232 interface bus. An input connector for an external keyboard is also provided.

Option 009, LO output on rear panel, provides local oscillator output and sweep + tune output at the rear panel for use with external tracking generators.

Option 010, tracking generator, provides a built-in tracking generator for the HP 8595A Spectrum Analyzer.

Option 101, fast time domain sweeps, provides fast analog-to-digital conversion of data for sweep times to 20 μ s in zero span.

Option 102, AM/FM speaker and TV sync trigger, enables the user to listen to a demodulated signal using either amplitude or frequency demodulation. It also allows the user to trigger on a selected line of a video picture frame.

Option 103, quasi-peak detector and AM/FM demodulator, enables the user to make automatic or manual quasi-peak measurements, to listen to a demodulated signal, and to use amplitude or frequency demodulation.

Option 105, time-gated spectrum analysis, allows the user to selectively measure the spectrum of signals that may overlap in the frequency domain, but be separated in the time domain.

Further information about the HP 8595A, and all its available options and accessories, is provided in the *HP 8594A/8595A Spectrum Analyzer Installation and Verification Manual*.

Serial-Number Label

Hewlett-Packard makes frequent improvements to its products to enhance their performance and reliability. HP service personnel have access to the records of design changes for each instrument, based on the instrument's serial number and option designation.

Whenever you contact Hewlett-Packard about your spectrum analyzer, have the complete serial number, firmware revision date, and option designation available. This will ensure that you obtain accurate service information.

A serial-number label is attached to the rear of the spectrum analyzer. This label has two instrument identification entries; the first provides the instrument's serial number and the second provides the identification number for each option built into the spectrum analyzer.

Serial Number Description

The serial number is divided into three parts. The first four digits are the serial-number prefix; the letter indicates the country of origin; the last five digits are the suffix. See Figure 1-2.

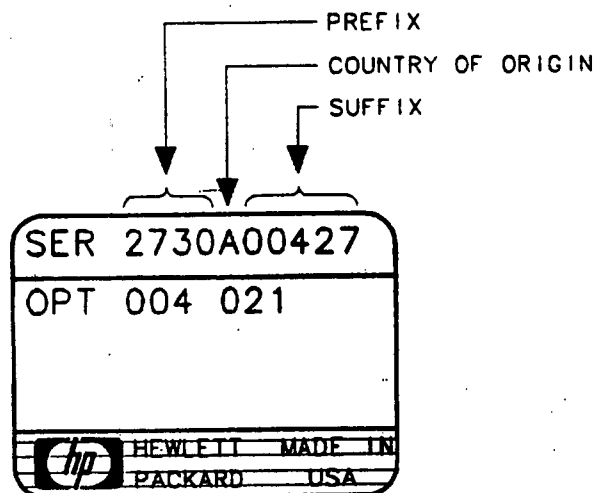

Figure 1-2. Typical Serial-Number Label

The serial-number prefix is a code that identifies the date of the last major design change that is built into the HP 8595A. The letter identifies the country where the unit was manufactured. The five-digit suffix is a sequential number and is different for each instrument.

Option Number

The serial-number label contains a three-digit option number for each option built into the spectrum analyzer. Each option number is entered sequentially below the serial number. See Figure 1-2.

Firmware Revision Date

When the spectrum analyzer is first turned on, a display appears that contains the copyright date and firmware revision date. (If the spectrum analyzer has either Option 021, HP-IB I/O, or Option 023, RS-232 I/O, the display will also contain the entries shown on the first line of the example below.) The version of firmware installed in the spectrum analyzer is identified by the day, month, and year in the following format:

```
(HP-IB: nn) or (RS232: nnnn)
COPYRIGHT HP 1986
rev dd.mm.yy
```

Whenever you contact Hewlett-Packard about your spectrum analyzer, be sure to provide the firmware date along with the complete serial number and option designation. This will ensure that you obtain accurate service information.

A history of firmware modification since the introduction of the HP 8595A is provided in Table 4-3, "Firmware History," located in Chapter 4. Each entry in the table contains the firmware revision date, part numbers for the four firmware EPROMs, the instrument serial-number break corresponding to the firmware change, and a brief description of the major firmware changes.

Firmware Upgrade Kit Ordering Information

There are occasions when the factory revises the instrument firmware to correct defects or make performance improvements. When a firmware revision is needed, a service note is distributed by the factory to all HP Service Centers. The service note identifies, by serial-number prefix, the instruments that require the latest firmware upgrade kit.

If your instrument requires a firmware upgrade kit it can be obtained by ordering FRMWR KT 92B/95A. Refer to "Ordering Information" in Chapter 4 for instructions on ordering parts.

Instructions for the replacement of the firmware ROMs is located under "A16 Processor/Video Board Firmware ROM" in Chapter 3.

Safety Considerations

Before servicing this instrument, familiarize yourself with the safety markings on the instrument and the safety instructions in this manual. This instrument has been manufactured and tested according to international safety standards. To ensure safe operation of the instrument and the personal safety of the user and service personnel, the cautions and warnings in this manual must be heeded.

Refer to the summary of safety considerations at the front of this manual. Individual chapters also contain detailed safety notation.

Warning



Failure to ground the instrument properly can result in personal injury, as well as instrument damage.

Before turning on the spectrum analyzer, connect a three-wire power cable with a standard IEC 320-C13 (CEE 22-V) inlet plug to the spectrum analyzer power receptacle. The power cable outlet plug must be inserted into a power-line outlet socket that has a protective earth-contact. **DO NOT** defeat the earth-grounding protection by using an extension cable, power cable, or autotransformer without a protective ground conductor.

If you are using an autotransformer, make sure its common terminal is connected to the protective ground conductor of its power-source outlet socket.

Reliability Considerations

Spectrum-Analyzer Input Protection

The spectrum-analyzer input circuitry can be damaged by power levels that exceed the maximum safe input-level specifications. Table 1-1 provides the input specifications. To prevent input damage, these specified levels must not be exceeded.

Table 1-1. HP 8595A Maximum Safe Input Level

Average continuous power	+30 dBm (1 watt, 7.1 Vrms), input attenuation ≥ 20 dB in band 1
Peak pulse power	+50 dBm (100 W) for $< 10 \mu\text{s}$ pulse width and $< 1\%$ duty cycle, input attenuation ≥ 30 dB
dc	0 V (dc coupled) 50 V (ac coupled)

The spectrum analyzer input can also be damaged by large transients. If it is likely that your HP 8595A will be exposed to potentially damaging transients, take whatever precautions are necessary to protect its input circuitry. The spectrum analyzer input can easily be protected by disconnecting it from the signal source whenever it is likely that large transients will be present. When it is impractical to disconnect the spectrum analyzer, a transient-limiting device should be used.

The HP 11947A Transient Limiter is an instrument accessory that protects the input circuitry from transients and accidental overloads. Contact your local Hewlett-Packard Sales or Service office for more information about the HP 11947A.

Caution



Transients are often produced during electromagnetic interference (EMI) conducted emissions testing. One type of device, the line impedance stabilization network (LISN), can produce large transients when its switch position or voltage input is changed.

Protection from Electrostatic Discharge

Electrostatic discharge (ESD) can damage or destroy electronic components. All work performed on assemblies containing electronic components should be done *only* at a static-safe work station.

Figure 1-3 shows an example of a static-safe work station using two types of ESD protection:

- Conductive table-mat and wrist-strap combination.
- Conductive floor-mat and heel-strap combination.

The two types must be used together to ensure adequate ESD protection. Refer to Table 1-2 for information on ordering static-safe accessories.

Warning

These techniques for a static-safe work station should not be used when working on circuitry that has a voltage potential greater than 500 volts.

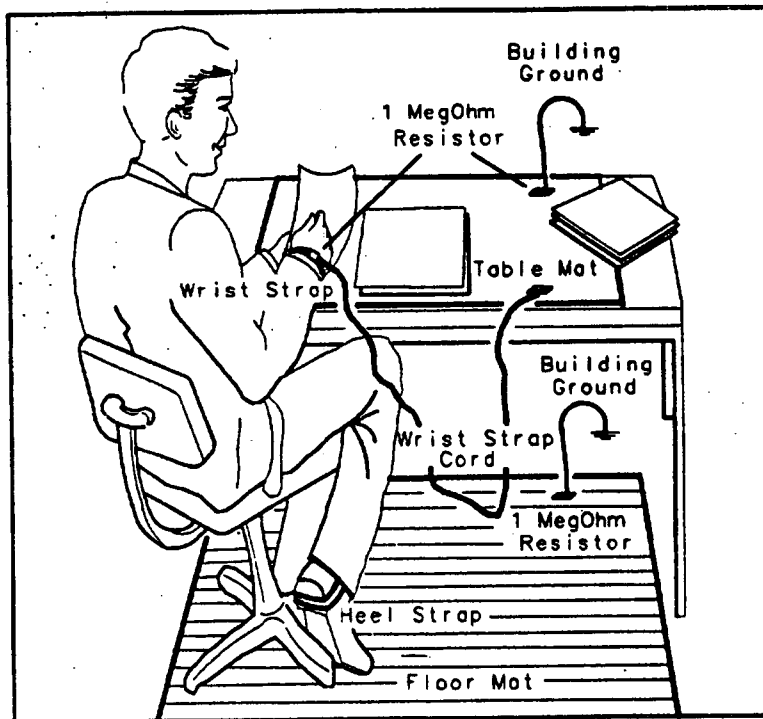

Figure 1-3. Example of a Static-Safe Work Station

Handling of Electronic Components and ESD

The possibility of unseen component damage caused by ESD is present whenever components are transported, stored, or used. The risk of ESD damage can be greatly reduced by close attention to how all components are handled.

- Perform work on all components at a static-safe work station.
- Keep static-generating materials at least one meter (40 inches) away from all components. Store or transport components in static-shielding containers.

Caution

Always handle printed circuit board assemblies by the edges. This will reduce the possibility of ESD damage to components and prevent contamination of exposed plating.

Test Equipment Usage and ESD

- Before connecting any coaxial cable to an instrument connector for the first time each day, momentarily short the center and outer conductors of the cable together.
- Personnel should be grounded with a 1 M Ω resistor-isolated wrist-strap before touching the center pin of any connector and before removing any assembly from the instrument.

- Be sure that all instruments are properly earth-grounded to prevent build-up of static charge.

For Additional Information about ESD

For more information about preventing ESD damage, contact the Electrical Overstress/Electrostatic Discharge (EOS/ESD) Association, Inc. The ESD standards developed by this agency are sanctioned by the American National Standards Institute (ANSI).

Table 1-2. Static-Safe Accessories

HP Part Number	Description
9300-0797*	Set includes: 3M static control mat 0.6 m x 1.2 m (2 ft x 4 ft) and 4.6 cm (15 ft) ground wire. (The wrist-strap and wrist-strap cord are not included. They must be ordered separately.)
9300-0980*	Wrist-strap cord 1.5 m (5 ft)
9300-1383*	Wrist-strap, color black, stainless steel, without cord, has four adjustable links and a 7 mm post-type connection.
9300-1169*	ESD heel-strap (reusable 6 to 12 months).
*Order through any Hewlett-Packard Sales and Service Office.	
92175A **	Black, hard-surface, static control mat, 1.2 m x 1.5 m (4 ft x 5 ft)
92175B **	Brown, soft-surface, static control mat, 2.4 m x 1.2 m (8 ft x 4 ft)
92175C **	Small, black, hard-surface, static control mat, 1.2 m x 0.9 m (4 ft x 3 ft)
92175T **	Tabletop static control mat, 58 cm x 76 cm (23 in x 30 in)
92176A **	Natural color anti-static carpet, 1.8 m x 1.2 m (6 ft x 4 ft)
92176C **	Russet color anti-static carpet, 1.8 m x 1.2 m (6 ft x 4 ft)
92176B **	Natural color anti-static carpet, 2.4 m x 1.2 m (8 ft x 4 ft)
92176D **	Russet color anti-static carpet, 2.4 m x 1.2 m (8 ft x 4 ft)
**Order by calling HP DIRECT Phone (800) 538-8787 or through any Hewlett-Packard Sales and Service Office.	

Returning Instruments for Service

When an instrument is returned to a Hewlett-Packard service office for servicing, it must be adequately packaged and have a blue repair tag attached. Repair tags are provided at the end of this chapter.

When filling out the blue repair tag, please be as specific as possible about the nature of the problem. Include copies of additional failure information (such as instrument failure settings, data related to instrument failure, and error messages) along with the instrument being returned.

Please notify the service office before returning your instrument for service. Any special arrangements for the instrument can be discussed at this time. This will help the service office to service and return your instrument as quickly as possible.

The original shipping containers should be used. If the original materials were not retained, identical packaging materials are available through any Hewlett-Packard office. Figure 1-4 illustrates the factory packaging material and provides their corresponding part numbers.

Caution



Instrument damage can result from using packaging materials other than those specified. Never use styrene pellets as packaging material. They do not adequately cushion the instrument or prevent it from shifting in the carton. They may also cause instrument damage by generating static electricity.

1. Fill out a blue repair tag (located at the end of this chapter) and attach it to the instrument. Include any specific performance details related to the problem.

If a blue repair tag is not available, the following information should be returned with the instrument.

- a. Type of service required.
- b. Description of the problem:
 - Whether problem is constant or intermittent.
 - Whether instrument is temperature sensitive.
 - Whether instrument is vibration sensitive.
 - Instrument failure settings.
 - Error codes.
 - Performance data.
- c. Company name and return address.
- d. Name and phone number of technical contact person.
- e. Model number of returned instrument.
- f. Full serial number of returned instrument.
- g. List of any accessories returned with instrument.

2. Pack the instrument in the appropriate packaging material. See Figure 1-4.

If the original or equivalent packaging materials cannot be obtained, instruments can be packaged using the following instructions.

Caution

Inappropriate packaging of instruments may result in damage to the instrument during transit.

- a. Wrap the instrument in antistatic plastic to reduce the possibility of damage caused by ESD.
 - b. For instruments that weigh less than 54 kg (120 lb), use a double-walled, corrugated cardboard carton of 159 kg (350 lb) test strength.
 - c. The carton must be large enough to allow three to four inches on all sides of the instrument for packing material, and strong enough to accommodate the weight of the instrument.
 - d. Surround the equipment with three to four inches of packing material, to protect the instrument and prevent it from moving in the carton. If packing foam is not available, the best alternative is S.D-240 Air Cap™ from Sealed Air Corporation (Commerce, California 90001). Air Cap looks like a plastic sheet filled with air bubbles. Use the pink (antistatic) Air Cap™ to reduce static electricity. Wrapping the instrument several times in this material will protect the instrument and prevent it from moving in the carton.
3. Seal the carton with strong nylon adhesive tape.
 4. Mark the carton "FRAGILE, HANDLE WITH CARE".
 5. Retain copies of all shipping papers.

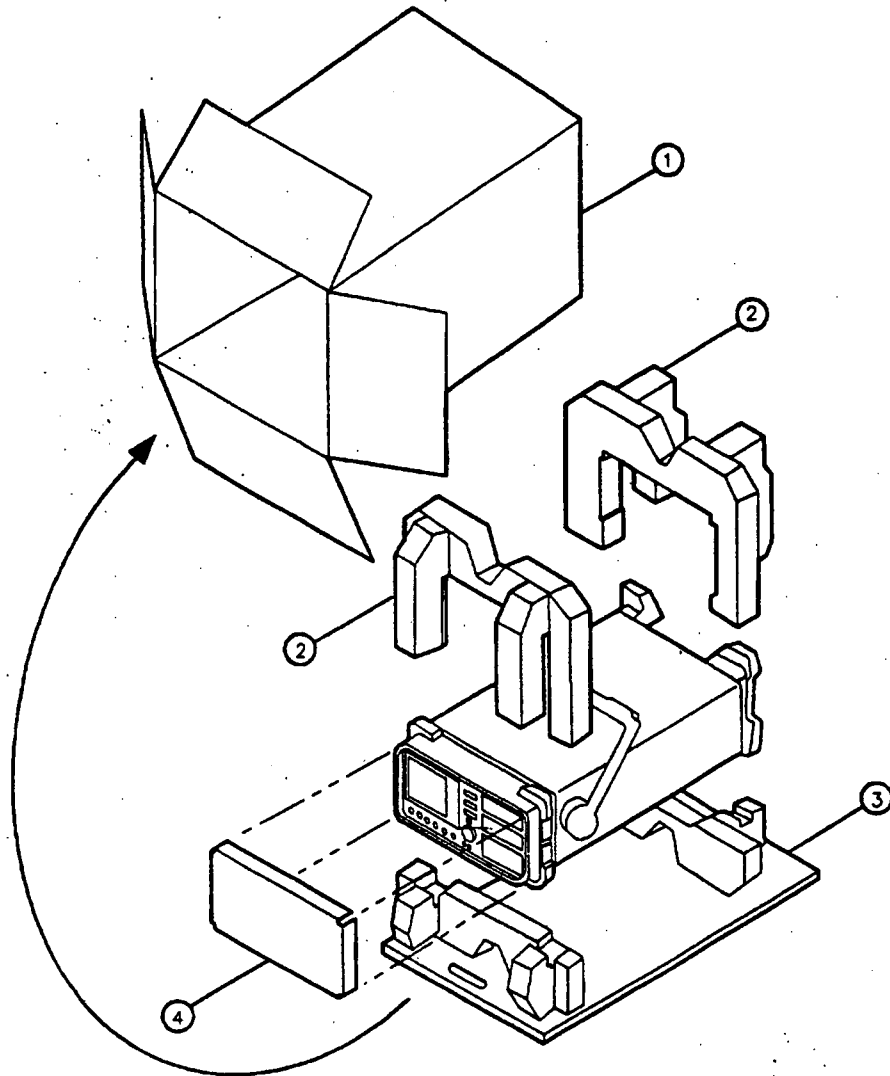

Item	HP Part Number	Description
1	9211-5636	Outer carton
2	08590-80013	Foam pad set
3	08590-80014	Bottom tray
4	9220-4488	Front frame insert

Figure 1-4. Instrument Packaging Material

Sales and Service Offices

Hewlett-Packard has sales and service offices located around the world to provide complete support for Hewlett-Packard products. To obtain servicing information or to order replacement parts, contact the nearest Hewlett-Packard Sales and Service Office listed in Table 1-3. In any correspondence or telephone conversation, refer to the instrument by its model number, serial number, firmware revision, and option designation.

Recommended Test Equipment

Equipment required for the adjustment, troubleshooting, and performance testing of the spectrum analyzer is listed in Table 1-4. Other equipment may be substituted for the recommended models, if it meets or exceeds the critical specifications listed in Table 1-4.

Recommended Service Tools

Table 1-5 and Figure 1-5 provide descriptions and HP part numbers for special service tools that are used throughout this manual.

Table 1-6 provides an additional list of common hand tools that are also recommended for repairing the HP 8595A.

Refer to "Ordering Information" in Chapter 4 when ordering service tools and accessories.

Table 1-3. Hewlett-Packard Sales and Service Offices

IN THE UNITED STATES	IN AUSTRALIA	IN JAPAN
California Hewlett-Packard Co. 1421 South Manhattan Ave. P.O. Box 4230 Fullerton, CA 92631 (714) 999-6700	Hewlett-Packard Australia Ltd. 31-41 Joseph Street Blackburn, Victoria 3130 895-2895	Yokogawa-Hewlett-Packard Ltd. 29-21 Takaido-Higashi, 3 Chome Suginami-ku Tokyo 168 (03) 331-6111
Hewlett-Packard Co. 301 E. Evelyn Mountain View, CA 94039 (415) 694-2000	IN CANADA Hewlett-Packard (Canada) Ltd. 17500 South Service Road Trans-Canada Highway Kirkland, Quebec H9J 2X8 (514) 697-4232	IN PEOPLE'S REPUBLIC OF CHINA China Hewlett-Packard, Ltd. P.O. Box 9610, Beijing 4th Floor, 2nd Watch Factory Main Bldg. Shuang Yu Shu, Bei San Huan Rd. Beijing, PRC 256-6888
Colorado Hewlett-Packard Co. 24 Inverness Place, East Englewood, CO 80112 (303) 649-5000	IN FRANCE Hewlett-Packard France F-91947 Les Ulis Cedex Orsay (6) 907-78-25	
Georgia Hewlett-Packard Co. 2000 South Park Place P.O. Box 105005 Atlanta, GA 30339 (404) 955-1500	IN GERMAN FEDERAL REPUBLIC Hewlett-Packard GmbH Vertriebszentrale Frankfurt Berner Strasse 117 Postfach 560 140 D-6000 Frankfurt 56 (0611) 50-04-1	IN SINGAPORE Hewlett-Packard Singapore Pte. Ltd. 1150 Depot Road Singapore 0410 273 7388 Telex HPSGSO RS34209 Fax (65) 2788990
Illinois Hewlett-Packard Co. 5201 Tollview Drive Rolling Meadows, IL 60008 (312) 255-9800	IN GREAT BRITAIN Hewlett-Packard Ltd. King Street Lane Winnersh, Wokingham Berkshire RG11 5AR 0734 784774	IN TAIWAN Hewlett-Packard Taiwan 8th Floor, Hewlett-Packard Building 337 Fu Hsing North Road Taipei (02) 712-0404
New Jersey Hewlett-Packard Co. 120 W. Century Road Paramus, NJ 07653 (201) 265-5000	IN OTHER EUROPEAN COUNTRIES Hewlett-Packard (Schweiz) AG Allmend 2 CH-8967 Widen (Zurich) (0041) 57 31 21 11	IN ALL OTHER LOCATIONS Hewlett-Packard Inter-Americas 3495 Deer Creek Rd. Palo Alto, California 94304
Texas Hewlett-Packard Co. 930 E. Campbell Rd. Richardson, TX 75081 (214) 231-6101		

Table 1-4. Recommended Test Equipment (1 of 5)

Instrument	Critical Specifications for Equipment Substitution	Recommended Model	Use*
Synthesized sweeper (two required)	Frequency range: 10 MHz to 6.5 GHz Frequency accuracy (CW): $\pm 0.02\%$ Leveling modes: internal and external Modulation modes: AM Power level range: -35 to +16 dBm	HP 8340A/B	P,A,T
Synthesizer function generator	Frequency range: 0.1 Hz to 500 Hz Frequency accuracy: $\pm 0.02\%$ Waveform: triangle	HP 3325B	P,T
Synthesizer/ level generator	Frequency range: 500 Hz to 80 MHz Amplitude range: +12 to -85 dBm Flatness: ± 0.15 dB Attenuator accuracy: ± 0.09 dB	HP 3335A	P,A,T
AM/FM signal generator	Frequency range: 1 MHz to 1000 MHz Amplitude range: -35 to +16 dBm SSB noise: < -120 dBc/Hz at 20 kHz offset	HP 8640B Option 002	P,A,T
Measuring receiver	Compatible with power sensors dB relative mode Resolution: 0.01 dB Reference accuracy: $\pm 1.2\%$	HP 8902A	P,A,T
Power meter	Power range: calibrated in dBm and dB relative to reference power -70 dBm to +44 dBm, sensor dependent	HP 436A	P,A,T
Power sensor	Frequency range: 1 MHz to 350 MHz Maximum SWR: 1.1 (1 MHz to 2.0 GHz) 1.30 (2.0 to 2.9 GHz)	HP 8482A	P,A,T
Low power sensor	Frequency range: 300 MHz Amplitude range: -20 dBm to -70 dBm Maximum SWR: 1.1 (300 MHz)	HP 8484A	P,T,A
Power sensor	Frequency range: 50 MHz to 6.5 GHz Maximum SWR: 1.15 (50 MHz to 100 MHz) 1.10 (100 MHz to 2 GHz) 1.15 (2.0 GHz to 6.5 GHz) HP 8485A	P,A,T	
* P = Performance Test, A = Adjustment, T = Troubleshooting			

Table 1-4. Recommended Test Equipment (2 of 5)

Instrument	Critical Specifications for Equipment Substitution	Recommended Model	Use*
Microwave frequency counter	Frequency range: 9 MHz to 7 GHz Timebase accy (Aging): $<5 \times 10^{-10}$ /day	HP 5343A	P,A,T
Spectrum analyzer	Frequency range: 10 MHz to 7 GHz	HP 8566A/B	A,T
Universal† Frequency Counter	Frequency: 10 MHz Resolution: ± 0.002 Hz External timebase	HP 5334A/B	P,A,T
Frequency standard	Frequency: 10 MHz Timebase accy (Aging): $<1 \times 10^{-9}$ /day	HP 5061B	P,A
Oscilloscope	Bandwidth: dc to 100 MHz Vertical scale factor of 0.5 V to 5 V/Div External trigger mode	HP 1741A	T
Digital voltmeter	Input resistance: ≥ 10 megohms Accuracy: ± 10 mV on 100 V range	HP 3456A	P,A,T
DVM test leads	For use with HP 3456A	HP 34118	A,T
Power splitter	Frequency range: 50 kHz to 6.5 GHz Insertion loss: 6 dB (nominal) Output tracking: <0.25 dB Equivalent output SWR: $<1.22:1$	HP 11667B	P,A
Directional bridge	Frequency range: 0.1 to 110 MHz Directivity: >40 dB Maximum VSWR: 1.1:1 Transmission arm loss: 6 dB (nominal) Coupling arm loss: 6 dB (nominal)	HP 8721A	P,T
Directional coupler	Frequency range: 1.7 GHz to 6.5 GHz Coupling: 16 dB (nominal) Max. coupling deviation: ± 1 dB Directivity: 14 dB minimum Flatness: 0.75 dB maximum VSWR: <1.45 Insertion loss: <1.3 dB	HP 0955-0125	P,T
<p>* P = Performance Test, A = Adjustment, T=Troubleshooting</p> <p>† HP 8595A Option 004</p>			

Table 1-4. Recommended Test Equipment (3 of 5)

Instrument	Critical Specifications for Equipment Substitution	Recommended Model	Use*
Low pass filter	Cutoff Frequency: 300 MHz Bandpass insertion loss: <0.9 dB at 300 MHz Stopband insertion loss: >40 dB at 435 MHz	HP 0955-0455	P,A,T
10 dB attenuator	Type N (m to f) Frequency: 300 MHz	HP 8491A Option 010	
20 dB attenuator	Type N (m to f) Attenuation: 20 dB Frequency: dc to 12.4 GHz	HP 8491A Option 020	A
1 dB step attenuator	Attenuation range: 0 to 12 dB Frequency range: 50 MHz Connectors: BNC female	HP 355C	P,A
10 dB step attenuator	Attenuation range: 0 to 30 dB Frequency range: 50 MHz Connectors: BNC female	HP 355D	P,A
Low pass filter	Cutoff frequency: 4.4 GHz Rejection at 5.5 GHz: >40 dB	HP 11689A	P,T
Low pass filter	Cutoff frequency: 50 MHz Rejection at 80 MHz: >50 dB	0955-0306	P,T
Termination	Impedance: 50Ω (nominal)	HP 909D	P,T
Logic Pulser	TTL voltage and current drive levels	HP 546A	T
Digital current tracer	Sensitivity: 1 mA to 500 mA Frequency response: Pulse trains to 10 MHz Minimum pulse width: 50 ns Pulse rise time: <200 ns	HP 547A	T
Logic clip	TTL voltage and current drive levels	HP 548A	T
Cable †	BNC, 50Ω, 23 cm (9 in)	8120-2682	P,A,T
Cable ‡	SMA (m) to type N (m) 22 cm (8.7 in)	8120-5148	P,A,T

* P = Performance Test, A = Adjustment, T=Troubleshooting

† Calibration (CAL) cable used with the standard model spectrum analyzer.

‡ YTF calibration (YTF CAL) cable used with the standard model spectrum analyzer.

Table 1-4. Recommended Test Equipment (4 of 5)

Instrument	Critical Specifications for Equipment Substitution	Recommended Model	Use*
Cable (two required)	Frequency range: 10 MHz to 6.5 GHz Maximum SWR: <1.4 at 6.5 GHz Length: ≥91 cm (36 in) Connectors: APC 3.5 (m) both ends Maximum insertion loss 2 dB	8120-4921	P,A
Cable	SMA (m) to SMA (m), 30 cm (12 in)	08592-60061	P,A,T
Cable	Frequency range: 50 MHz to 7 GHz Length: ≥91 cm (36 in) Connectors: SMA (m) both ends	5061-5458	P,A,T
Cable (four required)	Frequency range: dc to 1 GHz Length: ≥91 cm (36 in) Connectors: BNC (m) both ends	10503A	P,A,T
Cable	Frequency range: dc to 310 MHz Length: 20 cm (9 in) Connectors: BNC (m) both ends	10502A	P,A,T
Test cable (two required)	Length: ≥91 cm (36 in) Connectors: SMB (f) to BNC (m)	85680-60093	A,T
Cable assembly	Length: approximately 15 cm (6 in) Connectors: BNC (f) to Alligator Clips	8120-1292	A
Cable assembly	Length: ≥91 cm (36 in) Connectors: Banana Plug to Alligator Clips	HP 11102A	A
Adapter	Type N (f) to Type N (f)	1250-1472	P,A,T
Adapter (four required)	Type N (m) to BNC (f)	1250-1476	P,A,T
Adapter	Type N (m) to BNC (m)	1250-1473	P,A,T
Adapter	Type N (f) to BNC (m)	1250-1477	P,A,T
Adapter	Type N (f) to SMA (f)	1250-1772	P,A,T

* P = Performance Test, A = Adjustment, T=Troubleshooting

Table 1-4. Recommended Test Equipment (5 of 5)

Instrument	Critical Specifications for Equipment Substitution	Recommended Model	Use*
Adapter	Type N (m) to APC-3.5 (m)	1250-1743	P,A,T
Adapter	Type N (f) to APC-3.5 (f)	1250-1745	P,A,T
Adapter	APC-3.5 (f) to APC-3.5 (f)	5061-5311	P,A,T
Adapter	Type N (m) to APC-3.5 (f)	1250-1744	P,A,T
Adapter	SMA (f) to SMA (f)	1250-1158	P,A,T
Adapter	SMA (m) to SMA (m)	1250-1159	P,A,T
Adapter	SMB (m) to SMB (m)	1250-0813	A,T
Adapter	BNC (m) to BNC (m)	1250-0216	P,A,T
Adapter	SMC (m) to SMC (m)	1250-0827	A,T
Adapter	BNC tee (m)(f)(f)	1250-0781	T
Adapter	BNC (f) to SMB (m)	1250-1237	A,T

* P = Performance Test, A = Adjustment, T=Troubleshooting

Table 1-5. Special Service Tools

Item	Description	HP Part Number	Use*
1	Board puller, two prongs to lift PC boards	03950-4001	A,T
2	Extender board, pin and socket, 20 contacts (two required)	5062-1999	T
3	Extender board, pin and socket, 60 contacts	5062-2000	T
4	Extender board, 22 pin edge connector, 44 contacts	08565-60107	T
5	Injector board	5062-6421	A,T
6	Crystal bandwidth shorts (set of three)	5062-4855	A,T
	<i>Components Needed to Build One Crystal Short</i>		
6a	0.01 μ F capacitor	0160-4832	
6b	90.0 Ω resistor	0757-0400	
6c	Square, single-connector terminal (two required)	1251-4182	
6d	Two-terminal connector body	1251-0689	
6e	3/16 inch dia. heat shrink tubing, 1 1/8 inches long	0890-0029	
7	Combination wrench, 5/16 inch, with slotted box end (two required)	08555-20097	A,R
8	Combination wrench, 1/4 inch	8720-0014	R
9	Open end wrench, 15/64 inch, open end	8710-0946	R
10	Torque wrench, break-away, 10 inch-pounds, 5/16 inch, open end	40-60271 †	R
11	Cable puller, pry-bar style	5021-6773	A,T,R
12	Alignment tool, metal tip, plastic body	8710-0630	A,T
13	Alignment tool, nonmetallic tip, fiber body	8710-0033	A,T
14	TORX hand driver with required T8 and T10 bits, included in TORX driver kit with multiple bits (See tool-tip illustration)	8710-1426	A,R

*A = Adjustment, T = Troubleshooting, R = Replacement Procedure

† The part number provided is a non-HP part number. This tool can be ordered from:

Assembly Systems Inc.
16595 Englewood Avenue
Los Gatos, California 95032
(408) 395-5315

If you order a similar tool from your local supplier, it is important that the outside dimension of the wrench be no wider than 0.518 inches. This allows the wrench to be used on semirigid cable connectors in confined areas.

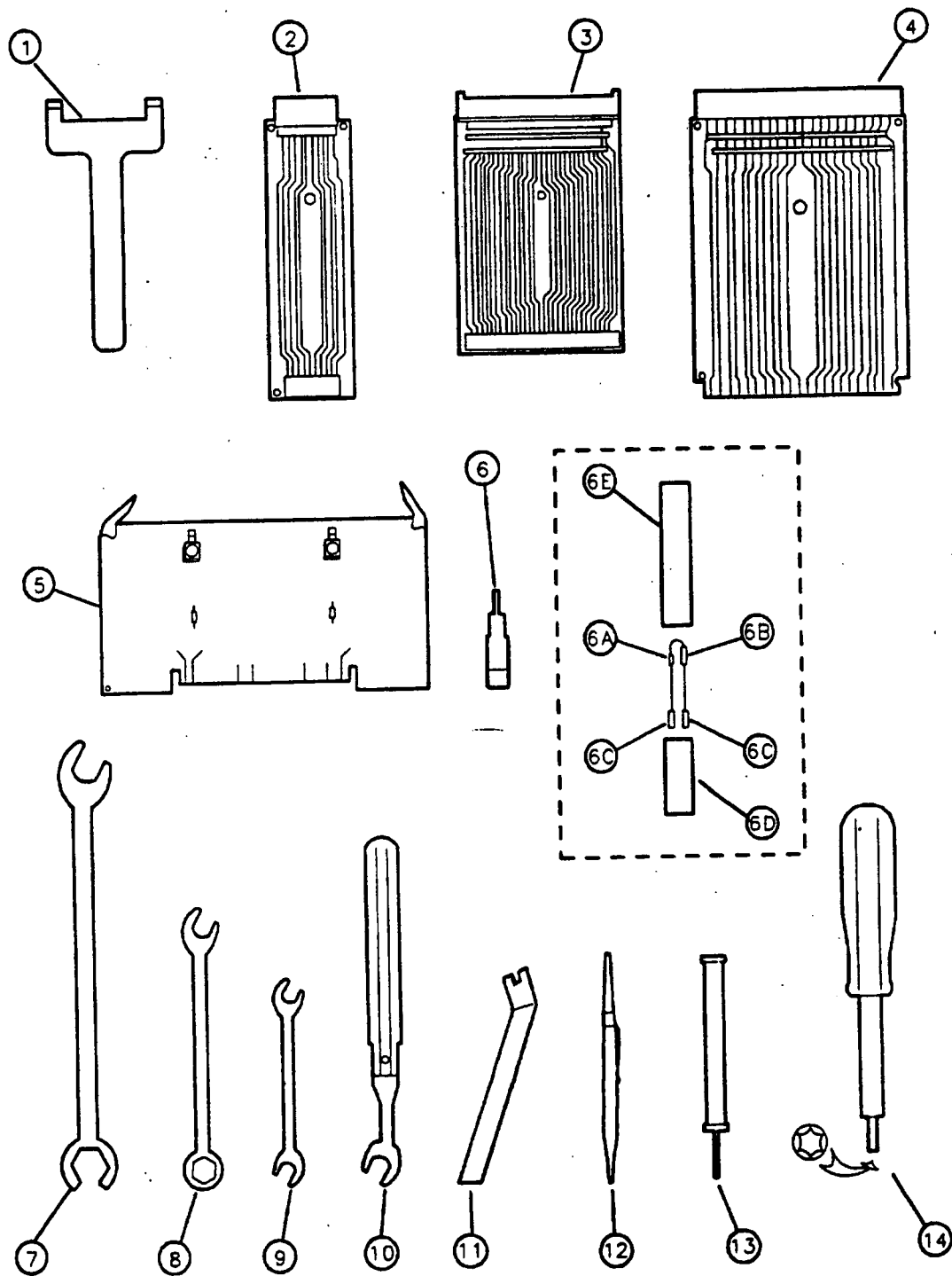

Figure 1-5. Special Service Tools

Table 1-6. Required Common Hand Tools

Description	HP Part Number	Use*
Hex (Allen) wrench, 3mm	8710-1392	R
Hex (Allen) wrench, 4mm	8710-1755	A,R
Hex (Allen) wrench, no. 4	5020-0288	R
Hex (Allen) wrench, no. 6	5020-0289	R
Nut driver, 7mm	8710-1217	R
Nut driver, 3/8 inch	8720-0005	R
Nut driver, 5/16 inch	8720-0003	R
Nut driver, 7/16 inch	8720-0006	R
Nut driver, 9/16 inch, drilled out, end covered with heatshrink tubing to protect front/rear-panel surface	8720-0008	R
Phillips Screwdriver, small no. 0	8710-0978	R
Posidriv screwdriver, small no. 1	8710-0899	A,R
Posidriv screwdriver, large no. 2	8710-0900	A,R
Long-nose pliers	8710-0003	R
Wire cutters	8710-0012	R
Wire strippers	8710-0058	R
* A = Adjustment, T = Troubleshooting, R = Replacement Procedure		

Adjustment Procedures

The procedures in this chapter adjust the spectrum analyzer's electrical performance to the specifications described in Table 1-3 of the *HP 8594A/8595A Spectrum Analyzer Installation and Verification Manual*.

If one or more spectrum analyzer assemblies has been replaced or repaired, related adjustment procedures should be done prior to performing the operation verification. Refer to the "Adjustments and Tests for Replaced or Repaired Assemblies" table in Chapter 6 when an assembly is replaced or repaired for a list of the required adjustments. It is important that adjustments are performed in the order indicated to ensure that the instrument meets all of its specifications.

Most adjustments require access to the interior of the spectrum analyzer.

Commands within parenthesis after a softkey, for example (ON), are used throughout this chapter to indicate the part of a softkey that should be underlined when the key is pressed.

Warning



The spectrum analyzer contains potentially hazardous voltages. Refer to the safety symbols provided on the spectrum analyzer, and in the general safety instructions in this manual, before operating the unit with the cover removed. Ensure that safety instructions are strictly followed. Failure to do so can result in severe or fatal injury.

Before You Start

There are three things you must do *before* attempting the adjustment procedures in this chapter:

- Familiarize yourself with the safety symbols marked on the spectrum analyzer, and read the general safety instructions and the symbol definitions given in the front of the Service Manual.
 - Allow the spectrum analyzer to warm up at least 30 minutes at room temperature.
-

Note



The spectrum analyzer must be allowed to stand at room temperature at least 2 hours prior to the 30 minute warm-up.

- Read the rest of this section.

Contents

The adjustments contained in this chapter are listed below in Table 2-1.

Table 2-1. HP 8595A Spectrum Analyzer Adjustments

Adjustment Number	Adjustment Name
1	Power Supply
2	Display
3	Sampler Match
4	10 MHz Reference (Standard)
5	10 MHz Reference (Option 004)
6	Crystal and LC Bandwidth Filter
7	Cal Attenuator Error Correction
8	Log and Linear Amplifier
9	CAL FREQ Adjustment Routine
10	CAL AMPTD Adjustment Routine
11	CAL YTF Adjustment Routine
12	CAL MXR Adjustment Routine
13	Third Converter and Second IF Bandpass
14	Comb Generator
15	Frequency Response
16	Time and Date
17	First LO Distribution Amplifier Adjustment (Option 009, 010)
18	BITG Power Level Adjustments (Option 010)
19	Tracking Oscillator Adjustment (Option 010)

Recommended Test Equipment

Each adjustment procedure includes a list of the equipment and accessories required for that adjustment. Table 1-4 lists the recommended test equipment needed to maintain and adjust the spectrum analyzer. Although Hewlett-Packard equipment is recommended, equivalent equipment may be used, provided it meets the critical specifications shown in Table 1-4.

Abnormal Indications During Adjustment

If the indications received during an adjustment do not agree with the normal conditions given in the adjustment procedures, a fault exists in your spectrum analyzer. The fault should be repaired *before* proceeding with any further adjustments. Refer to the troubleshooting and repair information in Chapter 6 of this manual.

Periodically Verifying Calibration

The spectrum analyzer requires periodic verification of operation. Under most conditions of use, you should test the spectrum analyzer at least once a year. To verify spectrum analyzer operation and calibration completely, you should run the entire set of performance tests indicated in the *HP 8594A/8595A Spectrum Analyzer Installation and Verification Manual*. When test results show proper operation and calibration, no adjustments are needed. However, if test results indicate that the instrument does not meet specifications, the cause should be determined and rectified. Refer to the troubleshooting information in Chapter 6 before attempting recalibration.

Standard-Value Replacement Components

The following tables provide part numbers for standard-value replacement components used in the adjustment procedures.

- Table 2-2 lists standard value replacement capacitors.
- Table 2-3 lists standard value replacement resistors, 0.125 W.
- Table 2-4 lists standard value replacement resistors, 0.5 W.

Table 2-2. Standard Value Replacement Capacitors

Capacitors					
Type: Tubular Range: 1 to 24 pF Tolerance: 1 to 9.1 pF = ± 0.25 pF 10 to 24 pF = $\pm 5\%$			Type: Dipped Mica Range: 27 to 470 pF Tolerance: $\pm 5\%$		
Value (pF)	HP Part Number	CD	Value (pF)	HP Part Number	CD
1.0	0160-2236	8	27	0160-2306	3
1.2	0160-2237	9	30	0160-2199	2
1.5	0150-0091	8	33	0160-2150	5
1.8	0160-2239	1	36	0160-2308	5
2.0	0160-2240	4	39	0140-0190	7
2.2	0160-2241	5	43	0160-2200	6
2.4	0160-2242	6	47	0160-2307	4
2.7	0160-2243	7	51	0160-2201	7
3.0	0160-2244	8	56	0140-0191	8
3.3	0150-0059	8	62	0140-0205	5
3.6	0160-2246	0	68	0140-0192	9
3.9	0160-2247	1	75	0160-2202	8
4.3	0160-2248	2	82	0140-0193	0
4.7	0160-2249	3	91	0160-2203	9
5.1	0160-2250	6	100	0160-2204	0
5.6	0160-2251	7	110	0140-0194	1
6.2	0160-2252	8	120	0160-2205	1
6.8	0160-2253	9	130	0140-0195	2
7.5	0160-2254	0	150	0140-0196	3
8.2	0160-2255	1	160	0160-2206	2
9.1	0160-2256	2	180	0140-0197	4
10.0	0160-2257	3	200	0140-0198	5
11.0	0160-2258	4	220	0160-0134	1
12.0	0160-2259	5	240	0140-0199	6
13.0	0160-2260	8	270	0140-0210	2
15.0	0160-2261	9	300	0160-2207	3
16.0	0160-2262	0	330	0160-2208	4
18.0	0160-2263	1	360	0160-2209	5
20.0	0160-2264	2	390	0140-0200	0
22.0	0160-2265	3	430	0160-0939	4
24.0	0160-2266	4	470	0160-3533	0

Table 2-3. Standard Value Replacement Resistors, 0.125 W

Resistors					
Type: Fixed-Film					
Range: 10Ω to 464 kΩ					
Wattage: 0.125 at 125°C					
Tolerance: ±1.0%					
Value (Ω)	HP Part Number	CD	Value (Ω)	HP Part Number	CD
10.0	0757-0346	2	422	0698-3447	4
11.0	0757-0378	0	464	0698-0082	7
12.1	0757-0379	1	511	0757-0416	7
13.3	0698-3427	0	562	0757-0417	8
14.7	0698-3428	1	619	0757-0418	9
16.2	0757-0382	6	681	0757-0419	0
17.8	0757-0294	9	750	0757-0420	3
19.6	0698-3429	2	825	0757-0421	4
21.5	0698-3430	5	909	0757-0422	5
23.7	0698-3431	6	1.0K	0757-0280	3
26.1	0698-3432	7	1.1K	0757-0424	7
28.7	0698-3433	8	1.21K	0757-0274	5
31.6	0757-0180	2	1.33K	0757-0317	7
34.8	0698-3434	9	1.47K	0757-1094	9
38.3	0698-3435	0	1.62K	0757-0428	1
42.2	0757-0316	6	1.78K	0757-0278	9
46.4	0698-4037	0	1.96K	0698-0083	8
51.1	0757-0394	0	2.15K	0698-0084	9
56.2	0757-0395	1	2.37K	0698-3150	6
61.9	0757-0276	7	2.61K	0698-0085	0
68.1	0757-0397	3	2.87K	0698-3151	7
75.0	0757-0398	4	3.16K	0757-0279	0
82.5	0757-0399	5	3.48K	0698-3152	8
90.9	0757-0400	9	3.83K	0698-3153	9
100	0757-0401	0	4.22K	0698-3154	0
110	0757-0402	1	4.64K	0698-3155	1
121	0757-0403	2	5.11K	0757-0438	3
133	0698-3437	2	5.62K	0757-0200	7
147	0698-3438	3	6.19K	0757-0290	5
162	0757-0405	4	6.81K	0757-0439	4
178	0698-3439	4	7.50K	0757-0440	7
196	0698-3440	7	8.25K	0757-0441	8
215	0698-3441	8	9.09K	0757-0288	1
237	0698-3442	9	10.0K	0757-0442	9
261	0698-3132	4	11.0K	0757-0443	0
287	0698-3443	0	12.1K	0757-0444	1
316	0698-3444	1	13.3K	0757-0289	2
348	0698-3445	2	14.7K	0698-3156	2
383	0698-3446	3	16.2K	0757-0447	4

Table 2-3. Standard Value Replacement Resistors, 0.125 W (continued)

Resistors					
Type: Fixed-Film					
Range: 10 Ω to 464 k Ω					
Wattage: 0.125 at 125°C					
Tolerance: $\pm 1.0\%$					
Value (Ω)	HP Part Number	CD	Value (Ω)	HP Part Number	CD
17.8K	0698-3136	8	100K	0757-0465	6
19.6K	0698-3157	3	110K	0757-0466	7
21.5K	0757-0199	3	121K	0757-0467	8
23.7K	0698-3158	4	133K	0698-3451	0
26.1K	0698-3159	5	147K	0698-3452	1
28.7K	0698-3449	6	162K	0757-0470	3
31.6K	0698-3160	8	178K	0698-3243	8
34.8K	0757-0123	3	196K	0698-3453	2
38.3K	0698-3161	9	215K	0698-3454	3
42.2K	0698-3450	9	237K	0698-3266	5
46.4K	0698-3162	0	261K	0698-3455	4
51.1K	0757-0458	7	287K	0698-3456	5
56.2K	0757-0459	8	316K	0698-3457	6
61.9K	0757-0460	1	348K	0698-3458	7
68.1K	0757-0461	2	383K	0698-3459	8
75.0K	0757-0462	3	422K	0698-3460	1
82.5K	0757-0463	4	464K	0698-3260	9
90.9K	0757-0464	5			

Table 2-4. Standard Value Replacement Resistors, 0.5 W

Resistors					
Type: Fixed-Film					
Range: 10Ω to 1.47 MΩ					
Wattage: 0.5 at 125°C					
Tolerance: ±1.0%					
Value (Ω)	HP Part Number	CD	Value (Ω)	HP Part Number	CD
10.0	0757-0984	4	383	0698-3404	3
11.0	0575-0985	5	422	0698-3405	4
12.1	0757-0986	6	464	0698-0090	7
13.3	0757-0001	6	511	0757-0814	9
14.7	0698-3388	2	562	0757-0815	0
16.2	0757-0987	9	619	0757-0158	4
17.8	0698-3389	3	681	0757-0816	1
19.6	0698-3390	6	750	0757-0817	2
21.5	0698-3391	7	825	0757-0818	3
23.7	0698-3392	8	909	0757-0819	4
26.1	0757-0003	8	1.00K	0757-0159	5
28.7	0698-3393	9	1.10K	0757-0820	7
31.6	0698-3394	0	1.21K	0757-0821	8
34.8	0698-3395	1	1.33K	0698-3406	5
38.3	0698-3396	2	1.47K	0757-1078	9
42.2	0698-3397	3	1.62K	0757-0873	0
46.4	0698-3398	4	1.78K	0698-0089	4
51.1	0757-1000	7	1.96K	0698-3407	6
56.2	0757-1001	8	2.15K	0698-3408	7
61.9	0757-1002	9	2.37K	0698-3409	8
68.1	0757-0794	4	2.61K	0698-0024	7
75.0	0757-0795	5	2.87K	0698-3101	7
82.5	0757-0796	6	3.16K	0698-3410	1
90.0	0757-0797	7	3.48K	0698-3411	2
100	0757-0198	2	3.83K	0698-3412	3
110	0757-0798	8	4.22K	0698-3346	2
121	0757-0799	9	4.64K	0698-3348	4
133	0698-3399	5	5.11K	0757-0833	2
147	0698-3400	9	5.62K	0757-0834	3
162	0757-0802	5	6.19K	0757-0196	0
178	0698-3334	8	6.81K	0757-0835	4
196	0757-1060	9	7.50K	0757-0836	5
215	0698-3401	0	8.25K	0757-0837	6
237	0698-3102	8	9.09K	0757-0838	7
261	0757-1090	5	10.0K	0757-0839	8
287	0757-1092	7	12.1K	0757-0841	2
316	0698-3402	1	13.3K	0698-3413	4
348	0698-3403	2	14.7K	0698-3414	5

Table 2-4. Standard Value Replacement Resistors, 0.5 W (continued)

Resistors					
Type: Fixed-Film					
Range: 10Ω to 1.47 MΩ					
Wattage: 0.5 at 125°C					
Tolerance: ±1.0%					
Value (Ω)	HP Part Number	CD	Value (Ω)	HP Part Number	CD
16.2K	0757-0844	5	162K	0757-0130	2
17.8K	0698-0025	8	178K	0757-0129	9
19.6K	0698-3415	6	196K	0757-0063	0
21.5K	0698-3416	7	215K	0757-0127	7
23.7K	0698-3417	8	237K	0698-3424	7
26.1K	0698-3418	9	261K	0757-0064	1
28.7K	0698-3103	9	287K	0757-0154	0
31.6K	0698-3419	0	316K	0698-3425	8
34.8K	0698-3420	3	348K	0757-0195	9
38.3K	0698-3421	4	383K	0757-0133	5
42.2K	0698-3422	5	422K	0757-0134	6
46.4K	0698-3423	6	464K	0698-3426	9
51.1K	0757-0853	6	511K	0757-0135	7
56.2K	0757-0854	7	562K	0757-0868	3
61.9K	0757-0309	7	619K	0757-0136	8
68.1K	0757-0855	8	681K	0757-0869	4
75.0K	0757-0856	9	750K	0757-0137	9
82.5K	0757-0857	0	825K	0757-0870	7
90.9K	0757-0858	1	909K	0757-0138	0
100K	0757-0367	7	1M	0757-0059	4
110K	0757-0859	2	1.1M	0757-0139	1
121K	0757-0860	5	1.21M	0757-0871	8
133K	0757-0310	0	1.33M	0757-0194	8
147K	0698-3175	5	1.47M	0698-3464	5

1. Power Supply

Description

The +5.1 V power supply is adjusted for $+5.1 \text{ V} \pm 0.05 \text{ V}$ using a digital voltmeter.

Equipment

Test Equipment

Digital Multimeter	HP 3456A
DMM Test Leads	HP 34118A

Adjustment Procedure

1. Turn the spectrum analyzer **LINE** switch to OFF. Remove the instrument cover assembly. Refer to the "Instrument Cover" removal procedure in Chapter 3 of this manual.
2. Connect the DMM test leads from the chassis (ground) to A16TP403. See Figure 2-1.

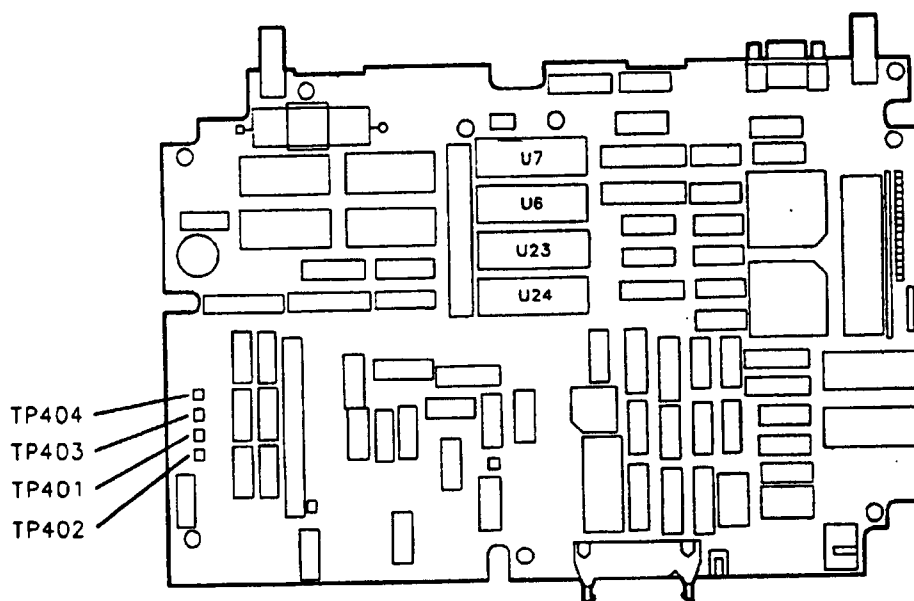

Figure 2-1. A16 Power Supply Test Point Location

3. Turn the spectrum analyzer **LINE** switch to ON. Adjust the +5.1 V adjustment (earlier units are labeled +5.2 V), for a voltage reading of $+5.1 \text{ V} \pm 0.05 \text{ V}$ (see Figure 2-2).

1. Power Supply

5.1V ADJUSTMENT

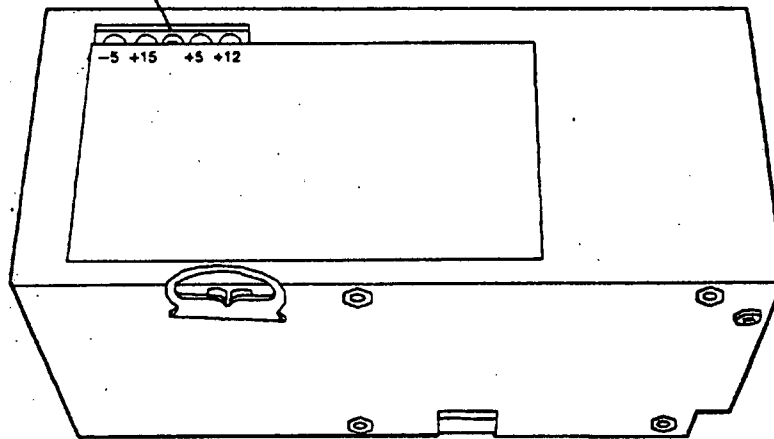

Figure 2-2. Power Supply Adjustment Location

4. The +15 V, -15 V, +12 V power supplies may be checked for proper operation. Refer to Table 2-5.

Table 2-5. Power Supply Tolerances

Power Supply	Test Point	Specification
+5.1 V	A16TP403	+5.1 V \pm 0.05 V
+12.0 V*	A16TP404	+12.0 V \pm 0.60 V
+15.0 V*	A16TP401	+15.0 V \pm 0.30 V
-15.0 V*	A16TP402	-15.0 V \pm 0.75 V
* These power supplies cannot be adjusted.		

2. Display

Description

The horizontal and vertical display positions are adjusted using **CRT HORZ POSITION** and **CRT VERT POSITION**. These positions are then stored in nonvolatile memory.

There are two focus adjustments, fine and coarse. The fine adjustment is located on the left side of the display assembly and can be accessed with the instrument cover on or off. The coarse adjustment is located on the rear of the display assembly and can only be adjusted with the instrument cover off.

Adjustment Procedure

Display Position

1. Press the following spectrum analyzer keys to adjust the horizontal position:

PRESET

CAL MORE 1 of 3

CRT HORZ POSITION

2. Rotate the knob until the display is centered horizontally.
3. Press the following spectrum analyzer softkey to adjust the vertical position:

CRT VERT POSITION

4. Rotate the knob until the display is centered vertically.
5. Press the following spectrum analyzer keys to store the horizontal and vertical position values into nonvolatile analyzer memory:

CAL

CAL STORE

Fine Focus Adjustment

6. Adjust the front panel **INTENSITY** control for a comfortable viewing intensity.
7. Use an adjustment tool to access the fine focus adjustment. See Figure 2-3. Adjust as necessary for a focused display. If one of the end-stops of the fine focus adjustment is reached, proceed with the "Coarse Focus Adjustment" section.

2. Display

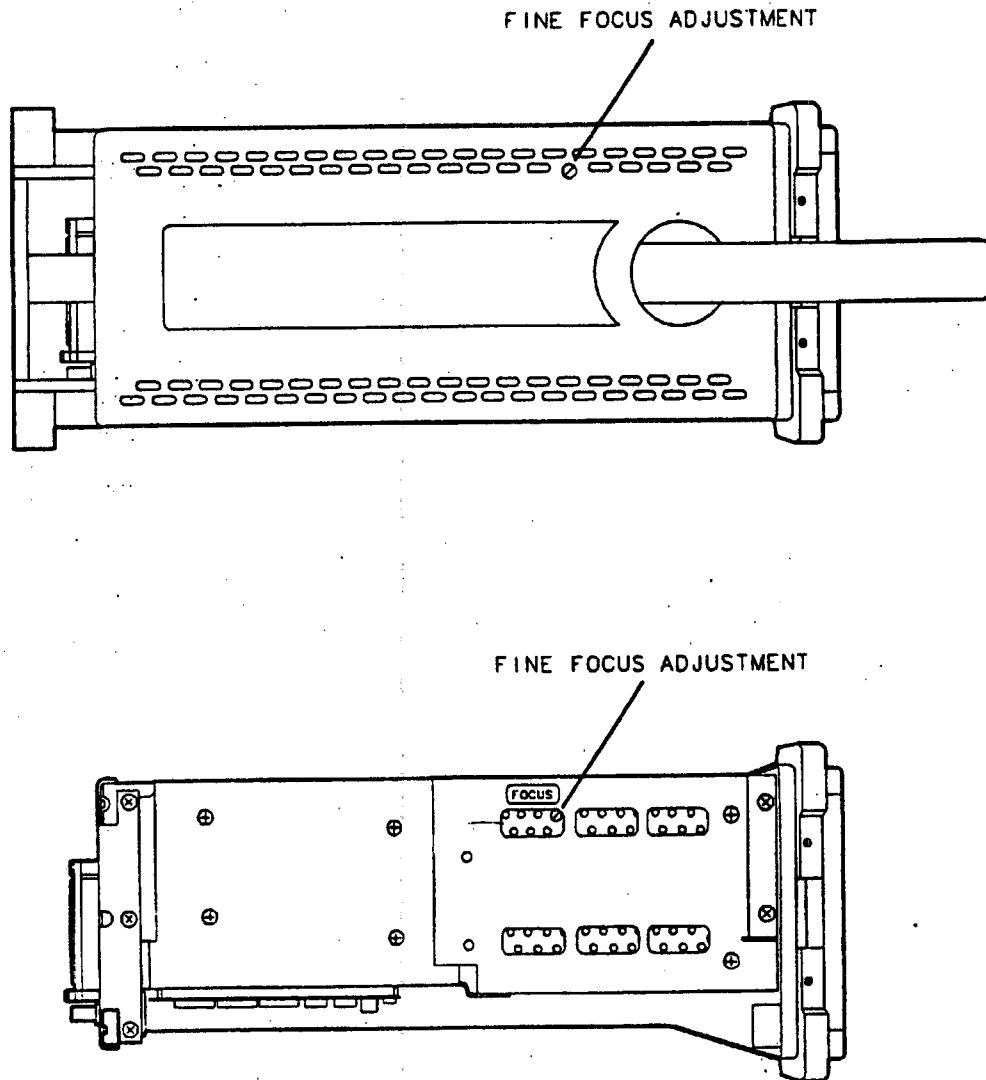

Figure 2-3. Fine Focus Adjustment Location

Coarse Focus Adjustment

8. Turn the spectrum analyzer **LINE** switch to OFF. Remove the instrument cover assembly. Refer to the "Instrument Cover" removal procedure in Chapter 3 of this manual.
9. Turn the spectrum analyzer **LINE** switch to ON.
10. Center the fine focus adjustment. Refer to Figure 2-3 for the adjustment location.
11. Adjust the coarse focus adjustment for the best possible focus.

Note



There are two ways to access the coarse focus adjustment without removing the display. Both may require a concentrated light source, such as a flashlight.

1. Bend an adjustment tool at a 90° angle. Looking at the top of the spectrum analyzer, locate the coarse focus adjustment through the back access hole of the display assembly. Refer to Figure 2-4 and Figure 2-5. Engage the adjustment tool and rotate the adjustment in small increments until the desired focus is obtained.
 2. Using a thin, narrow, insulated adjustment tool, approach the adjustment at a 90° angle through the oval access hole on the top of the display assembly. See Figure 2-4.
-

2. Display

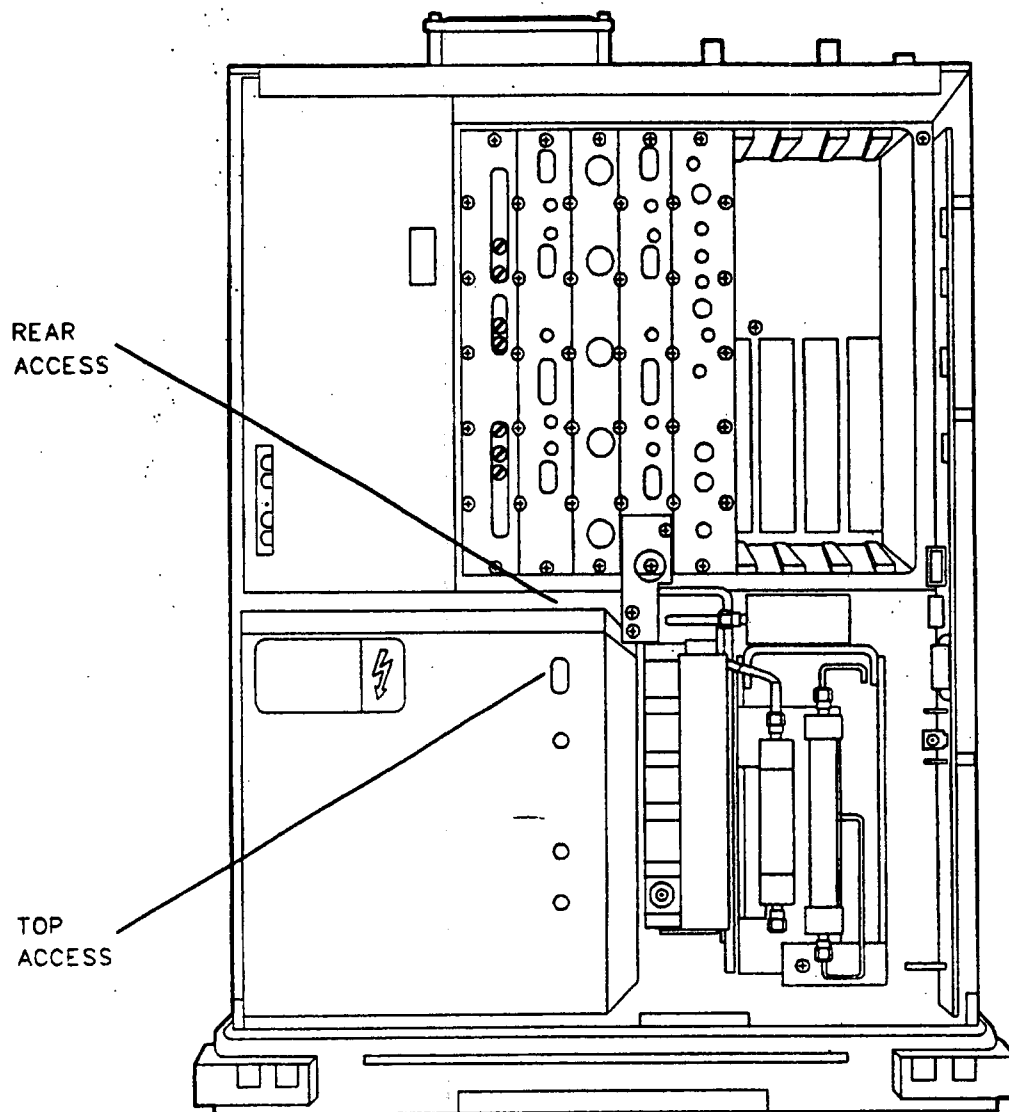

Figure 2-4. Coarse Focus Adjustment Location

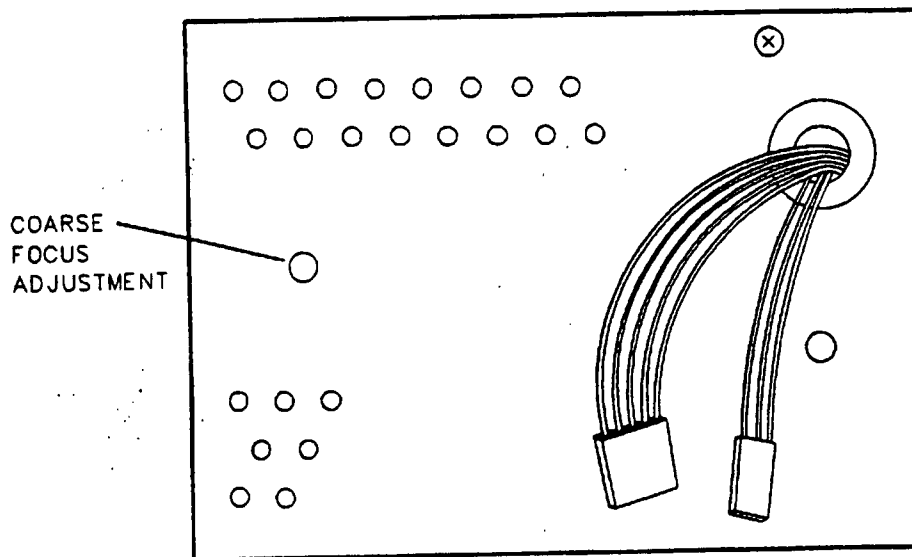

Figure 2-5. Coarse Focus Adjustment Location (Rear View of Display Assembly)

3. Sampler Match

Description

The match between the sampling oscillator and the sampler is optimized by first setting the sampling-oscillator frequency for midrange, then adjusting the sampler-match adjustment for maximum dc volts as read on a digital multimeter.

Equipment

Test Equipment

Digital Multimeter	HP 3456A
DMM Test Leads	HP 34118A

Adjustment Procedure

1. Turn the spectrum analyzer **LINE** switch to OFF. Remove the instrument cover assembly. Refer to the "Instrument Cover Removal" procedure in Chapter 3 of this manual.
2. Turn the spectrum analyzer **LINE** switch to ON.
3. Set the center frequency of the spectrum analyzer to 194 MHz. This forces the sampling oscillator to 288 MHz which is approximately the center of its range.
4. Connect the DMM from chassis ground to A25TP1. Refer to Figure 2-6.
5. Adjust A25C107 for maximum voltage as read on the DMM. This voltage must be between $+1.5\text{ V} \pm 1.0\text{ V}$.
6. Measure the voltage at A26TP2. It should be $-1.5\text{ V} \pm 1.0\text{ V}$. If it is not, readjust A25C107 until a compromise is established between the two test points, such that the voltage specifications of steps 5 and 6 are met. The absolute value of the final voltages in steps 5 and 6 should not be greater than 0.75 V.

3. Sampler Match

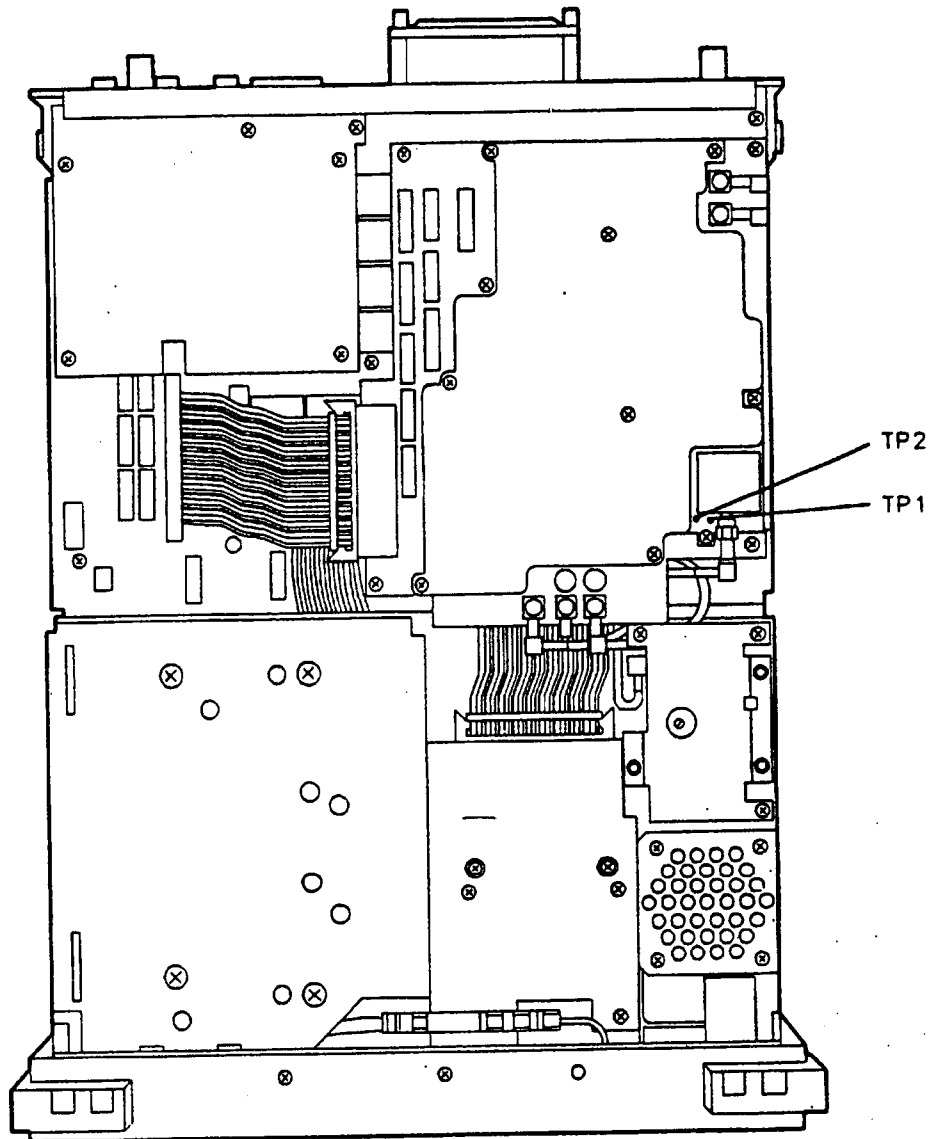

Figure 2-6. A25 Counter Lock Assembly Test Points

4. 10 MHz Reference (Standard)

Description

The internal 10 MHz time base is adjusted for frequency accuracy.

This procedure does not adjust for long-term drift or aging rate.

Only short-term accuracy is adjusted.

A frequency counter is connected to the CAL OUT, which is locked to the 10 MHz reference. This yields better effective resolution.

The time base is adjusted for a frequency of 300 MHz as read by the frequency counter.

Equipment

Test Equipment

Microwave Frequency Counter	HP 5343A
Frequency Standard	HP 5061A

Adjustment Procedure

1. Connect the equipment as shown in Figure 2-7.

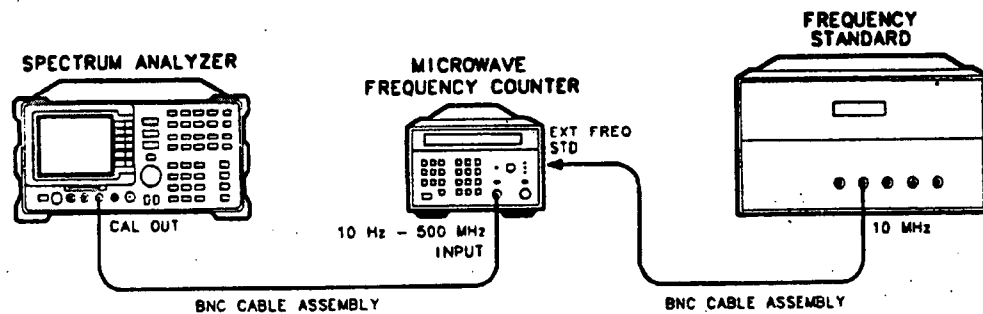

Figure 2-7. 10 MHz Reference Adjustment Setup

Note



To properly adjust the time base, a frequency standard with a better time base accuracy than that of the spectrum analyzer is required.

2. Set the HP 5343A controls as follows:

50 Ω /1 M Ω	50 Ω Impedance
10 Hz-500 MHz/500 MHz-18 GHz	10 Hz-500 MHz
SAMPLE RATE	Midrange
FREQUENCY STANDARD	EXTERNAL

3. Press the following spectrum analyzer keys:

FREQUENCY -2001 **Hz**

CAL MORE 1 of 3 MORE 2 of 3 **SERVICE CAL CAL TIMEBASE**

4. A number will be displayed in the active function block of the spectrum analyzer display. This is the setting of the DAC (0 to 255) which controls the frequency of the internal time base. Use the knob or keyboard to change the DAC setting until the frequency counter reads 300 MHz \pm 75 Hz (\pm 0.25 ppm).
5. Once the time base has been adjusted for minimum sideways movement press **CAL** **STORE**. The new DAC number is now stored in nonvolatile memory.

5. 10 MHz Reference Adjustment (Option 004)

Note



Replacement oscillators are factory adjusted after a complete warmup and after the specified aging rate has been achieved. Readjustment should not be necessary after oscillator replacement, and is not recommended.

Description

The frequency of the internal 10 MHz frequency reference is compared to a known frequency standard and adjusted for minimum frequency error. This procedure does not adjust the short-term stability or long-term stability of the 10 MHz Ovenized Crystal Oscillator (OCXO), which are determined by characteristics of the particular oscillator and the environmental and warmup conditions to which it has been recently exposed. The spectrum analyzer must be ON continuously for at least 24 hours immediately prior to oscillator adjustment to allow both the temperature and frequency of the oscillator to stabilize.

Equipment

Test Equipment

Frequency Standard any 10 MHz frequency standard with the accuracy of $\pm 10^{-10}$, such as the HP 5061B Cesium Beam Standard

Frequency Counter HP 5334A/B

Cable

BNC cable, 122 cm (48 in) (2 required) HP 10503A

Adjustment Procedure

Note



The spectrum analyzer must be ON continuously for at least 24 hours immediately prior to oscillator adjustment to allow both the temperature and frequency of the oscillator to stabilize. Failure to allow sufficient stabilization time could result in oscillator misadjustment.

1. Place the spectrum analyzer on its side as shown in Figure 2-8 and set the LINE switch of the spectrum analyzer to ON.
2. Allow the spectrum analyzer to remain powered ON and undisturbed for at least 24 hours, so that both the temperature and frequency of the OCXO can stabilize.
3. Connect the frequency standard to the frequency counter rear-panel TIMEBASE IN/OUT connector. Refer to Figure 2-8.
4. Disconnect the jumper between the 10 MHz REF OUTPUT and EXT REF IN jacks on the spectrum analyzer rear panel. Connect a BNC cable between the 10 MHz REF OUTPUT jack and INPUT A on the frequency counter.

5. 10 MHz Reference Adjustment (Option 004)

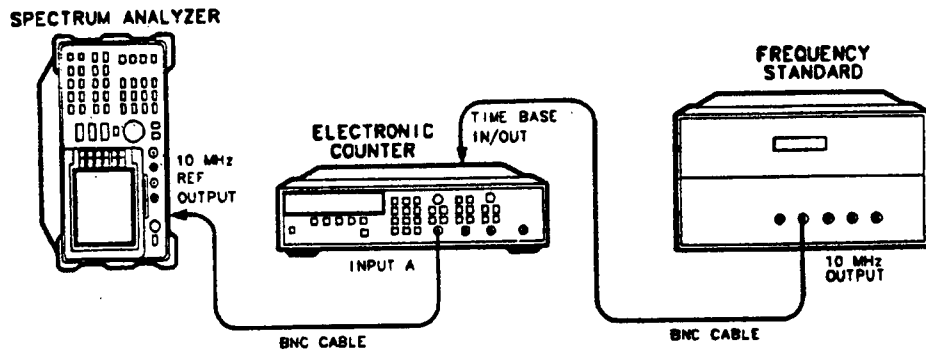

Figure 2-8. Precision Frequency Reference Setup

- Set the frequency counter controls as follows:

FUNCTION/DATA	FREQ A
INPUT A:	
x10 ATTN	OFF
AC	OFF (DC coupled)
50Ω Z	OFF (1 MΩ input impedance)
AUTO TRIG	ON
100 kHz FILTER A	OFF
INT/EXT switch (rear panel)	EXT

- On the frequency counter,

Select a 1 second gate time by pressing:

GATE TIME 1 **GATE TIME**

Offset the displayed frequency by -10.0 MHz by pressing:

MATH **SELECT/ENTER** **CHS/EEX** 10 **CHS/EEX** 6 **SELECT/ENTER** **SELECT/ENTER**

The frequency counter should now display the difference between the frequency of the INPUT A signal and 10.0 MHz with a displayed resolution of 10 MHz (0.010 Hz).

- Locate the FREQ ADJ control. See Figure 2-9. Remove the dust cap screw.
- Use a nonconductive adjustment tool to adjust the FREQ ADJ control on the OCXO for a frequency counter indication of 0.00 Hz.
- On the frequency counter, select a 10 second gate time by pressing **GATE TIME** 10 **GATE TIME**. The frequency counter should now display the difference between the frequency of the INPUT A signal and 10.0 MHz with a resolution of 0.001 Hz (1 MHz).
- Wait at least 2 gate periods for the frequency counter to settle, and then adjust the FREQ ADJ control on the OCXO for a stable frequency counter indication of 0.000 ±0.010 Hz.
- Replace the dust cap screw on the OCXO.

5. 10 MHz Reference Adjustment (Option 004)

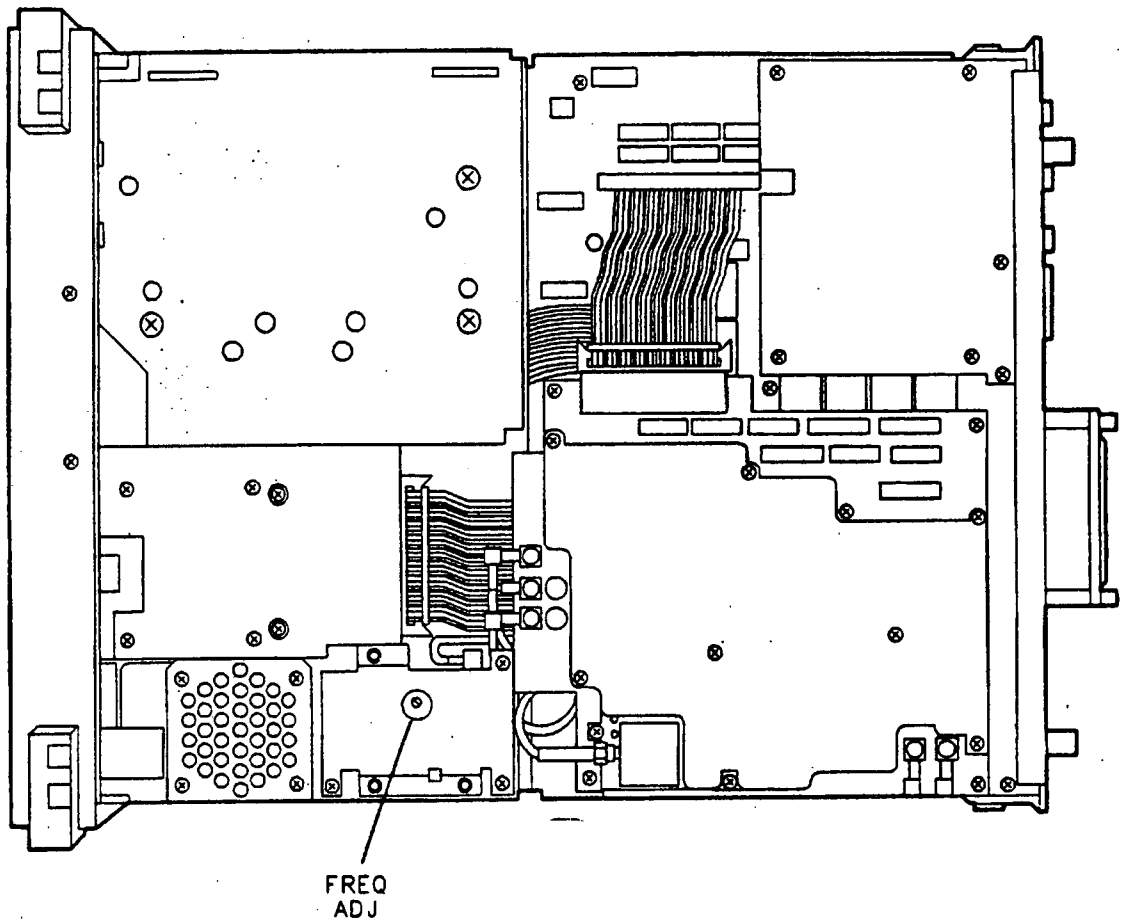

Figure 2-9. Oven Reference Adjustment Location

6. Crystal and LC Bandwidth Filter

Description

The crystal and LC bandwidth filter circuits are adjusted for symmetry, center frequency, and peak amplitude.

First, correction constants are turned off. This allows for uncorrected 3 dB resolution bandwidth centering and amplitude adjustments.

New corrections are then generated by running the CAL FREQ and CAL AMPTD adjustment routines.

Equipment

Test Equipment

Crystal Shorts (set of 3) HP 5062-4855

Cable

BNC Cable, 23 cm (9 in) HP 10503A

Adjustment Procedure

1. Turn the spectrum analyzer **LINE** switch to OFF. Remove the instrument cover assembly. Refer to the "Instrument Cover" removal procedure in Chapter 3 of this manual.
2. Turn the spectrum analyzer **LINE** switch to ON.
3. Press the following spectrum analyzer keys:

PRESET
CAL MORE 1 of 3
CORRECT ON OFF (OFF)

Crystal Alignment

4. Connect the CAL OUT to the INPUT 50Ω with the BNC cable.
5. Press the following spectrum analyzer keys:

FREQUENCY 300 **MHz**
SPAN 10 **MHz**
PEAK SEARCH
SIGNAL TRACK (ON)
SPAN 200 **kHz**
AMPLITUDE 20 **-dBm**
SCALE LOG LIN (LIN)
MORE 1 of 2 AMPTD UNITS dBm
BW 3 **kHz**

6. Press **AMPLITUDE**, then use the knob to place the signal at the sixth graticule line from the bottom.

6. Crystal and LC Bandwidth Filter

7. Press the following spectrum analyzer keys:

SIGNAL TRACK (OFF)
BW 30 **kHz**

Caution



Shorting the crystal test points to ground may permanently damage the bandwidth board assembly. If you make your own shorts, it is advisable to insulate the bare wires and connectors.

8. Connect the crystal shorts (through the access holes on the cover) across the following pairs of test points:

A13TP1 and A13TP2
A11TP1 and A11TP2
A11TP4 and A11TP5

9. Adjust A13C54 CTR for minimum signal amplitude. Then adjust A13C38 SYM and A13C54 CTR for a centered and symmetrical bandpass response as shown in Figure 2-10.

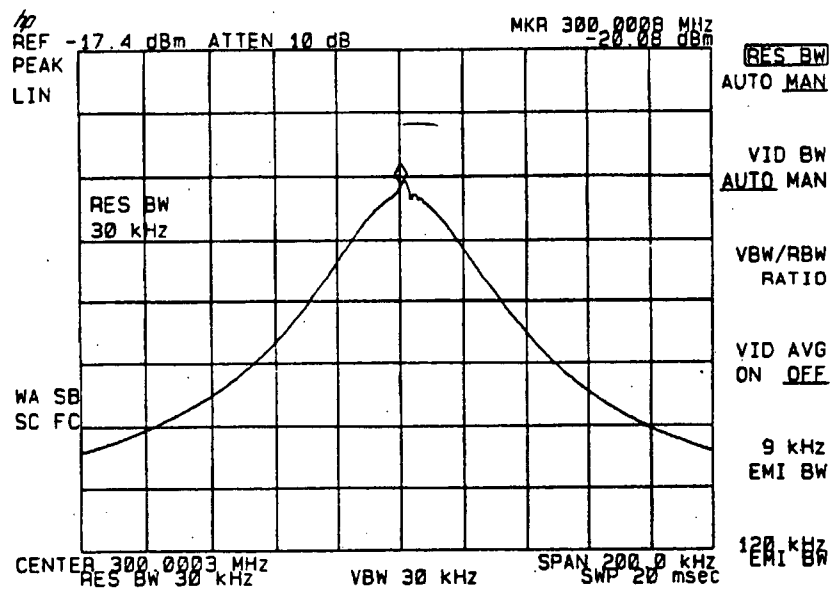

Figure 2-10. Crystal Symmetry and Centering

10. Remove the crystal short from A13TP1 and A13TP2 and connect it across A13TP4 and A13TP5.
11. Adjust A13C25 CTR for minimum signal amplitude. Then adjust A13C15 SYM and A13C25 CTR for a centered and symmetrical bandpass response.
12. Remove the crystal short from A11TP4 and A11TP5. Connect the short across A13TP1 and A13TP2.

6. Crystal and LC Bandwidth Filter

13. Adjust A11C54 CTR for minimum signal amplitude. Then adjust A11C38 SYM and A11C54 CTR for a centered and symmetrical bandpass response.
14. Remove the crystal short from A11TP1 and A11TP2. Connect the short across A11TP4 and A11TP5.
15. Adjust A11C25 CTR for minimum signal amplitude. Then adjust A11C15 SYM and A11C25 CTR for a centered and symmetrical bandpass response.
16. Remove the crystal shorts and press the following spectrum analyzer keys:

PEAK SEARCH
SIGNAL TRACK (ON)
SPAN 50 **kHz**
SIGNAL TRACK (OFF)
BW 3 **kHz**
PEAK SEARCH **MARKER DELTA**
BW 30 **kHz**
PEAK SEARCH

17. Verify that the MARKER Δ frequency does not exceed 3 kHz. If the signal shift is out of tolerance, repeat steps 4 through 17.
18. Press the following spectrum analyzer keys:

MKR
MARKERS OFF

LC Alignment Procedure

19. To access the LC dip capacitors C17 and C47, remove the covers from the A11 and A13 assemblies. See Figure 2-11.
20. Press the following spectrum analyzer keys:
BW 100 **kHz**
SPAN 5 **MHz**
21. Short A11TP3, A11TP6, and A13TP3 to ground to widen all but one of the LC filter poles.

Caution Use a tool with a nonmetallic body to make the LC dip adjustment.



Shorting components to ground may result in permanent damage to the bandwidth board assembly.

22. Center the signal on the spectrum analyzer display by pressing **PEAK SEARCH** and **SIGNAL TRACK** (ON). Then adjust A13C47 LC dip for a minimum signal amplitude.
23. Move the short from A13TP3 to A13TP6 and adjust A13C17 LC dip for a minimum signal amplitude.
24. Move the short from A11TP3 to A13TP3 and adjust A11C17 LC dip for a minimum signal amplitude.
25. Move the short from A11TP6 to A11TP3 and adjust A11C47 LC dip for a minimum signal amplitude.

6. Crystal and LC Bandwidth Filter

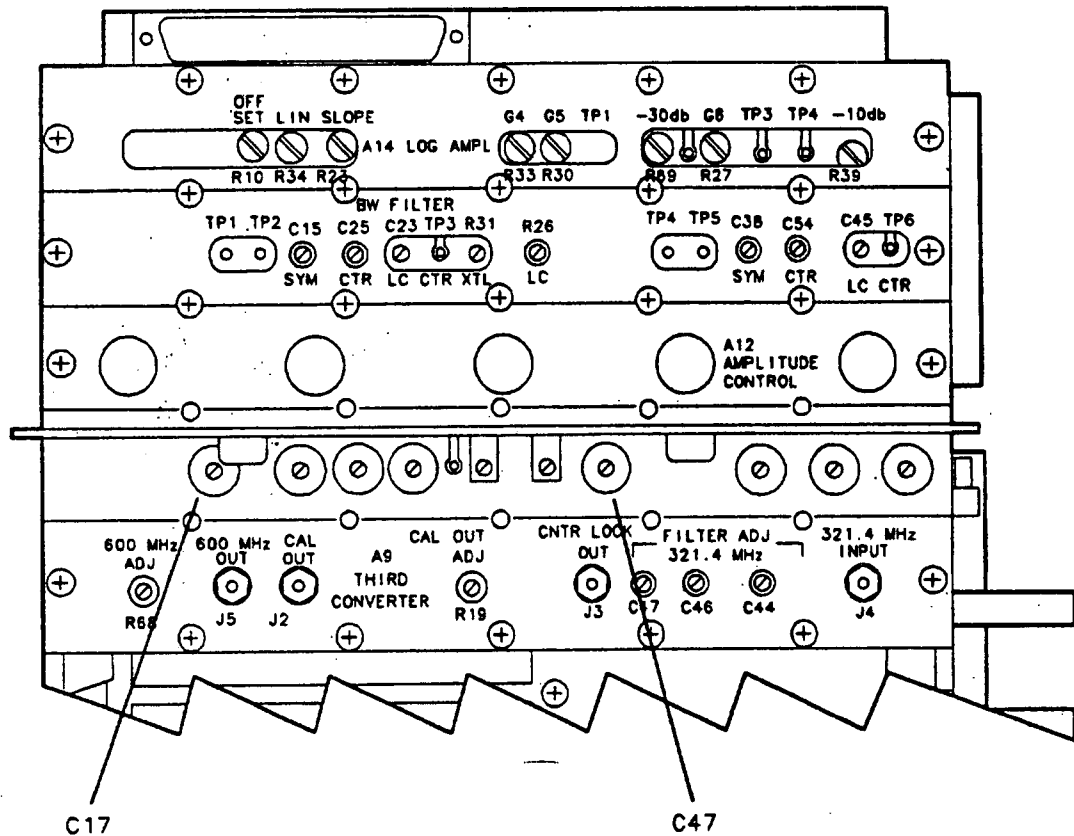

Figure 2-11. LC Dip Location

LC Centering Adjustment

26. Reinstall the covers on the A11 and A13 assemblies. Short A11TP3, A13TP6, and A13TP3 to ground. Press the following spectrum analyzer keys:

Note



The center frequency of the 100 kHz bandwidth is referenced to the 30 kHz bandwidth. During this procedure it is advisable to switch to the 30 kHz bandwidth occasionally and recenter it using **PEAK SEARCH** **MARKER** **> CF**.

27. Adjust A11C45 LC CTR for maximum signal at center-screen.
28. Move the short from A11TP3 to A11TP6 and adjust A11C23 LC CTR for maximum signal at center-screen.

6. Crystal and LC Bandwidth Filter

29. Move the short from A13TP6 to A11TP3 and adjust A13C45 LC CTR for maximum signal at center-screen.
30. Move the short from A13TP3 to A13TP6 and adjust A13C23 LC CTR for maximum signal at center-screen.
31. Disconnect all the shorts from A11 and A13 bandwidth board assemblies.

LC Amplitude Adjustment

32. Press the following spectrum analyzer keys:

BW 3 **MHz**
SPAN 2 **MHz**

33. Press **AMPLITUDE** and adjust the signal level one division down from the top graticule using the knob.
34. Press the following spectrum analyzer keys:

PEAK SEARCH
MARKER DELTA **MARKER DELTA**
SIGNAL TRACK (ON)
BW 100 **kHz**

35. Adjust A11R26 LC and A13R26 LC equally for a **MARKER Δ** amplitude of 0 dB.

Note



Each potentiometer should be adjusted to accomplish one-half of the necessary increase in signal amplitude. If A11R26 or A13R26 reaches its limit, recenter both potentiometers and repeat steps 32 through 35.

Final LC Centering Adjustment

36. Press the following spectrum analyzer keys:

BW 30 **kHz**
SPAN 100 **kHz**
PEAK SEARCH **MARKER Δ CF**
BW 100 **kHz**

37. Make final adjustments by adjusting A11C23, A11C45, A13C23, and A13C45 in succession to peak the amplitude of the marker at center-screen.
38. Repeat steps 36 and 37 until the 30 kHz and 100 kHz bandwidths are centered in relation to each other.
39. Press the following spectrum analyzer keys:

BW 30 **kHz**
PEAK SEARCH
MARKER DELTA **MARKER DELTA**
BW 100 **kHz**
PEAK SEARCH

40. Verify that the **MARKER Δ** frequency does not exceed 10 kHz.

6. Crystal and LC Bandwidth Filter

If the signal shift is out of tolerance, repeat steps 26 through 39.

Crystal Amplitude Adjustment

41. Press the following spectrum analyzer keys:

BW 30 **kHz**
SPAN 10 **kHz**
PEAK SEARCH
MARKER DELTA **MARKER DELTA**
SIGNAL TRACK (ON)
BW 1 **kHz**

42. Adjust A11R31 XTL and A13R31 XTL equally for a **MARKER Δ** amplitude reading of 0 dB.

Note



Each potentiometer should be adjusted to accomplish one-half of the necessary increase in signal amplitude. If A11R31 or A13R31 reaches its limit, recenter both potentiometers and repeat steps 41 and 42.

Final BW Amplitude Check

43. Run the "CAL FREQ Adjustment Routine" and the "CAL AMPTD Adjustment Routine".

44. Remember to press **CAL STORE** after the completion of the routines to store data in nonvolatile memory.

45. Press the following spectrum analyzer keys to verify that the bandwidth amplitude corrections are within specifications:

CAL **MORE 1 of 3** **MORE 2 of 3**
SERVICE DIAG
DISPLAY CAL DATA

46. Refer to the BW-AMP column of the spectrum analyzer display to locate the XTAL and LC bandwidth amplitude-correction numbers of the spectrum analyzer. All LC and XTAL bandwidth readings should be between -0.8 dB to +0.5 dB. Refer to Figure 2-12 for an example of the analyzer display. Table 2-6 shows the XTAL and LC bandwidth amplitude-correction numbers, using the readings of Figure 2-12 as an example.

6. Crystal and LC Bandwidth Filter

MISC-FREQ	RL-VENR	ERR	BW-AMP	LC-XTAL	SGAIN	RFATN	CAL FREQ & AMPTD
300000000	200	-0.08	0.00	0	255	0.06	0.07
126659000	200	-0.06	0.00	0	255	0.00	0.00
54820328	200	0.10	0.00	0	255	0.34	0.11
21641733	200	0.03	0.00	0	255	0.27	0.07
0.000203847	200	0.07	0.00	0	130	0.41	0.12
0.000001009	161	0.18	0.46	0	255	0.33	0.01
1079753938	161	0.18	0.06	0	221	0.31	0.15
2	161	0.18	-0.02	0	165	0.24	0.16
0	161	0.18	0.00	0	102	0.19	
0	161	0.18	0.00	0	32	0.20	
0.059218585	200	0.00	-0.27	47	255	1.785329103	
0	200	0.00	-0.40	103	255	1.812912941	CAL STORE
-9	200	0.00	-0.43	166	255	1.869230986	
1	200	0.00	-0.47	225	255	1.802058867	
1	200	0.00	-0.54	240	255	1.681241035	
65	200	0.00	-0.17	35	255	1.924278021	MORE 1 OF 3

Figure 2-12. Displayed Calibration Data

Table 2-6. Bandwidth Amplitude-Correction Map

Resolution Bandwidths	BW-AMP Correction Numbers
not used	0.00
not used	0.00
not used	0.00
not used	0.00
XTAL: 9 kHz	0.00
300 Hz	0.46
1 kHz	0.06
3 kHz	-0.02
10 kHz	0.00
30 kHz	0.00
LC: 100 kHz	-0.27
300 kHz	-0.40
1 MHz	-0.43
3 MHz	-0.47
5 MHz	-0.54
120 kHz	-0.17

6. Crystal and LC Bandwidth Filter

47. If the difference between the bandwidth amplitude-correction numbers of the 30 kHz XTAL and 3 MHz LC is greater than 0.8 dB, pad A11R8 or A13R8 and repeat the Final BW Amplitude Check. Refer to the Component Level Information Package for the location of A11R8 and A13R8.

Note

If the 30 kHz XTAL bandwidth amplitude correction is greater than the 3 MHz LC bandwidth correction, increase the value of A11R8 or A13R8.

If the 3 MHz LC bandwidth amplitude correction is greater than the 30 kHz XTAL bandwidth correction, decrease the value of A11R8 or A13R8.

48. If just the 100 kHz LC amplitude is out of range, repeat steps 23 through 38 and steps 43 through 46.
49. If the 1 kHz XTAL amplitude is out of the above range, repeat steps 41 through 46.

7. Cal Attenuator Error Correction

Description

The A12 Amplitude Control assembly has one 10 dB and two 20 dB nonadjustable amplifiers. It also has 1 dB, 2 dB, 4 dB, 8 dB, and 16 dB attenuators which are correctable. The 16 dB step is not used at this time.

The attenuator error correction procedure involves disabling the attenuator correction constants, determining the attenuator step errors, and entering the new correction constants into the spectrum analyzer memory.

Note



The accuracy of the amplitude control attenuator is critical to the proper calibration of the instrument; therefore, this procedure must be carefully and accurately performed.

Equipment

Test Equipment

Synthesizer/Level Generator HP 3335A

Cable

BNC cable, 120 cm (48 in) HP 10503A

Adapter

Adapter, Type N (m) to BNC (f) HP 1250-1476

Adjustment Procedure

1. Turn the spectrum analyzer **LINE** switch to OFF. Remove the instrument cover assembly. Refer to the "Instrument Cover" removal procedure in Chapter 3 of this manual.
2. Turn the spectrum analyzer **LINE** switch to ON.
3. Connect the 50Ω output of the HP 3335A to the spectrum analyzer INPUT 50Ω. See Figure 2-13.

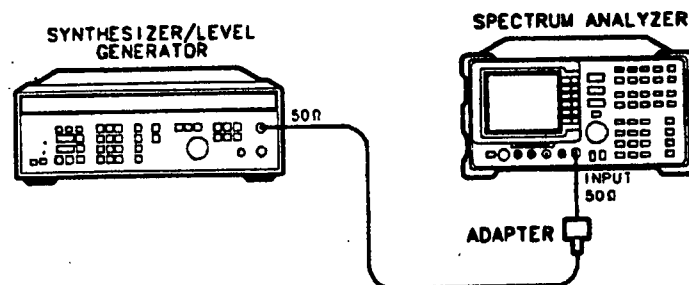

Figure 2-13. Cal Attenuator Error Correction Setup

4. Set the frequency of the HP 3335A to 25 MHz and the output to -19 dBm.

7. Cal Attenuator Error Correction

5. To turn the amplitude attenuator correction constants off, press the following spectrum analyzer keys:

PRESET
CAL MORE 1 of 3
CORRECT DN OFF (OFF)

1 dB Step Check

6. To measure the 1 dB step correction press the following spectrum analyzer keys:

FREQUENCY 25 (MHz)
SPAN 10 (MHz)
AMPLITUDE 18 (-dBm)
SCALE LOG LIN (LIN) MORE 1 of 2
AMPTD UNITS dBm
PEAK SEARCH
SIGNAL TRACK (ON)
SPAN 50 (kHz)
BW 3 (kHz)
VID BW AUTO MAN (MAN) 300 (Hz)

7. Press the following spectrum analyzer keys:

PEAK SEARCH **MARKER DELTA**
SIGNAL TRACK (ON)

8. The MKR Δ amplitude reading should be 0.0 dB \pm 0.01 dB. If it is not, repeat step 7.
9. Press **AMPLITUDE** 17 (-dBm).
10. Set the amplitude of the HP 3335A Synthesizer to -18 dBm.
11. Press **MKR** on the spectrum analyzer.
12. Record the MKR Δ amplitude reading in Table 2-7. This is the 1 dB attenuator step error of the A12 Amplitude Control assembly.

2 dB Step Check

13. Press the following spectrum analyzer keys:

AMPLITUDE 16 **-dBm**.

14. Set the amplitude of the HP 3335A Synthesizer to -17 dBm.

15. Press the following spectrum analyzer keys:

PEAK SEARCH

MARKER DELTA **MARKER DELTA**

SIGNAL TRACK (ON)

16. MKR Δ amplitude reading should be 0.0 ± 0.01 . If it is not, repeat step 15.
17. Press **AMPLITUDE** 14 **-dBm**.
18. Set the amplitude of the HP 3335A Synthesizer to -15 dBm.
19. Press **MKR** on the spectrum analyzer.
20. Record the MKR Δ amplitude reading in Table 2-7. This is the 2 dB attenuator step error of the A12 Amplitude Control assembly.

4 and 8 dB Step Error

21. Repeat steps 13 through 20 for attenuator steps 4 dB and 8 dB. Use Table 2-7 for synthesizer values and spectrum analyzer reference-level values.

Table 2-7. A12 Amplitude Control Assembly Attenuator Errors

Synthesizer Settings (dBm)		Reference Level Settings (dBm)		Attenuator Step (dB)	Error
Attenuator OFF	Attenuator ON	Attenuator OFF	Attenuator ON		
-19	-18	-18	-17	1	
-17	-15	-16	-14	2	
-18	-14	-17	-13	4	
-19	-11	-18	-10	8	

7. Cal Attenuator Error Correction

Enter Attenuator Error Correction Data

22. Press the following spectrum analyzer keys:

PRESET
FREQUENCY -2001 **Hz**
CAL **MORE 1 of 3** **MORE 2 of 3**
SERVICE CAL **SET ATTN ERROR**

Note The frequency of -2001 Hz is necessary to access the **SERVICE CAL** routines.



-
23. When the spectrum analyzer prompts you with the message **ENTER CAL ATTN ERROR**, enter the data from Table 2-7. Terminate the entry with either the **dBm** or **-dBm** key. When the spectrum analyzer prompts you to enter the 16 dB step, enter 0 dBm. At the completion of entering the 16 dB error, the spectrum analyzer will reset.
24. To confirm that the correct data is stored, access the cal attenuator corrections by pressing the following spectrum analyzer keys:

CAL **MORE 1 of 3** **MORE 2 of 3**
SERVICE DIAG
DISPLAY CAL DATA

Note that the cal-attenuator correction data are the first five corrections located in the ERR column.

8. Log and Linear Amplifier

Description

A 21.4 MHz signal is injected into an IF test board that has been inserted in place of the first resolution bandwidth assembly, A11. The gain of the A14 Log Amplifier Assembly is adjusted by observing the voltage at the AUX VIDEO OUT on the rear panel with a digital multimeter.

Equipment

Test Equipment

Synthesizer/Level Generator	HP 3335A
Digital Multimeter	HP 3456A
IF Test Board	HP 5062-6421

Cables

BNC Cable, 120 cm (48 in)	HP 10503A
BNC (f) to dual banana plug	HP 1251-2277
Test Cable	HP 85680-60093

Adjustment Procedure

1. Turn the spectrum analyzer **LINE** switch to OFF. Remove the instrument cover assembly. Refer to the "Instrument Cover" removal procedure in Chapter 3 of this manual.
2. Remove the first IF Bandwidth Filter assembly, A11. Install the IF test board into the A11 slot. Turn the spectrum analyzer **LINE** switch to ON.
3. Set the DMM to read dc volts.
4. Press the following spectrum analyzer keys:

```

PRESET
CAL MORE 1 of 3
CORRECT ON OFF (OFF) MORE 2 of 3
SERVICE DIAG
STP GAIN ZERO
SPAN 0 Hz
BW 10 kHz
VID BW AUTO MAN (MAN) 300 Hz
AMPLITUDE 10 -dBm
SCALE LOG LIN (LIN)
  
```

5. Set the synthesizer as follows:

```

FREQUENCY ..... 21.4 MHz
MANUAL TUNE ..... ON
AMPTD INCR ..... 0.01 dBm
AMPLITUDE ..... -6 dBm
  
```

8. Log and Linear Amplifier

6. Connect equipment as shown in Figure 2-14. Connect the output of the synthesizer to J2 of the IF test board. Connect the DMM to AUX VIDEO OUT (located on the rear panel).

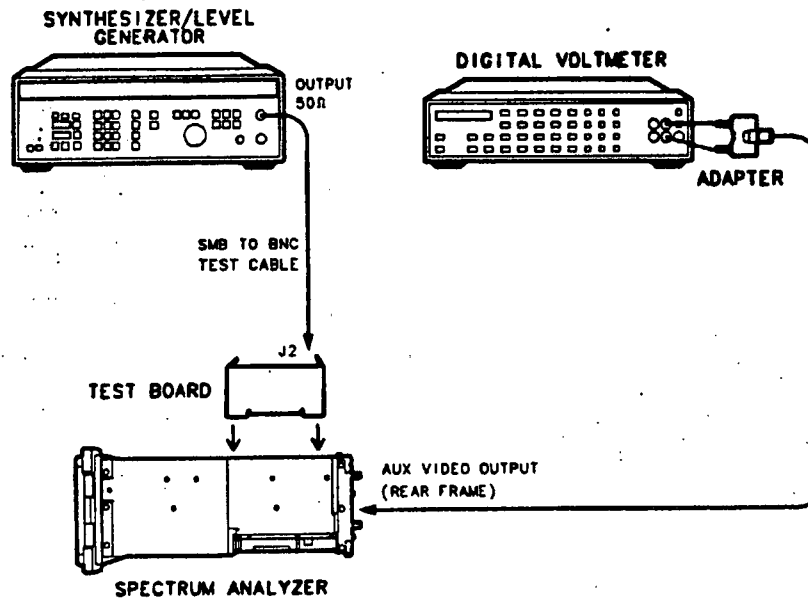

Figure 2-14. Log and Linear Amplifier Adjustment Setup

Log Fidelity Adjustment

7. Adjust the synthesizer knob for maximum signal amplitude on the display. Adjust the synthesizer amplitude as necessary to keep the signal on the display.
8. Adjust the synthesizer output level for a DMM reading of $1000 \text{ mV} \pm 1.0 \text{ mV}$. Record the synthesizer amplitude readout for later reference: _____ dBm
9. Press AMPTD INCR 10 dB on the synthesizer.
10. Press **SCALE** (LOG) on the spectrum analyzer.
11. Set the synthesizer to the level recorded in step 8 and adjust A14R23 SLOPE (refer to Figure 2-15) for a DMM reading of $1000 \text{ mV} \pm 1 \text{ mV}$.

8. Log and Linear Amplifier

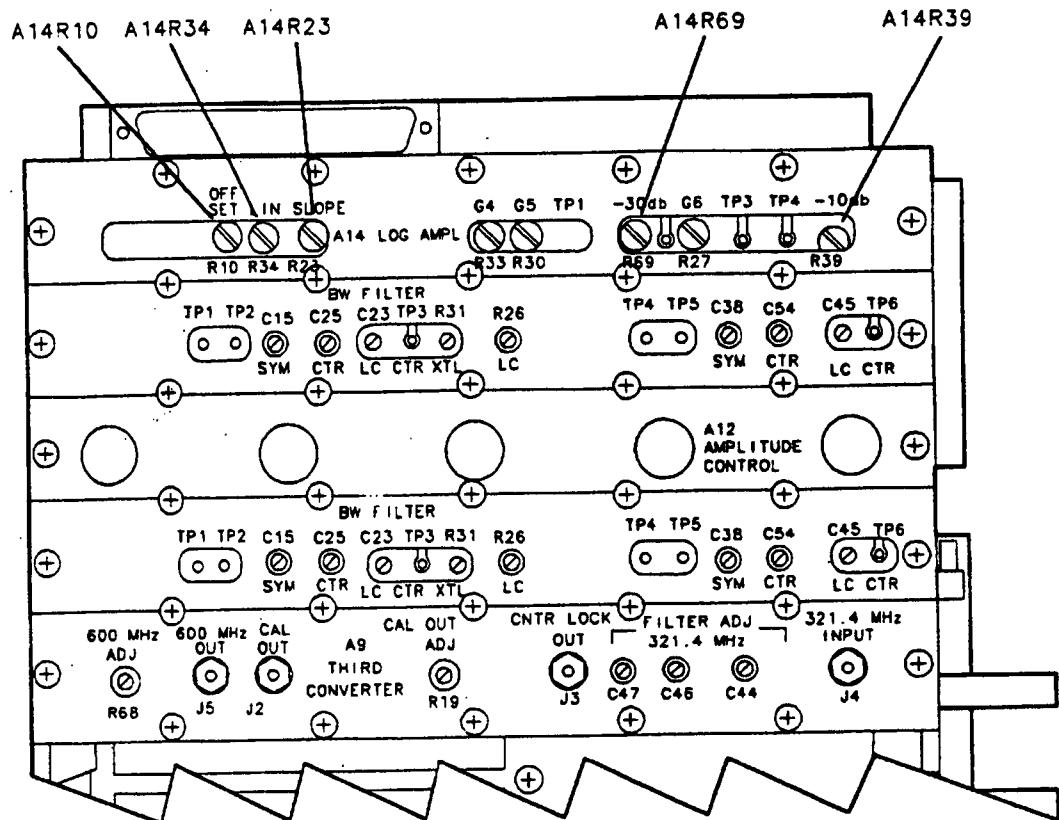

Figure 2-15. Log and Linear Amplifier Adjustment Location

12. Set the synthesizer amplitude 60 dB below that recorded in step 8 by pressing AMPLITUDE and then pressing STEP DOWN six times. Adjust A14R10 OFFSET for the DMM reading of $250 \text{ mV} \pm 1 \text{ mV}$.
13. Repeat steps 11 and 12 until no further adjustment is necessary.
14. Set the synthesizer amplitude 30 dB below that recorded in step 8 and adjust the A14R23 SLOPE for a DMM reading of $625 \text{ mV} \pm 1 \text{ mV}$.
15. Set the synthesizer amplitude to the level recorded in step 8 and adjust the A14R69 -30 dB for a DMM reading of $1000 \text{ mV} \pm 1 \text{ mV}$.
16. Repeat steps 14 and 15 until no further adjustment is necessary.
17. Set the synthesizer amplitude 10 dB below that recorded in step 8 and adjust the A14R23 SLOPE for a DMM reading of $875 \text{ mV} \pm 1 \text{ mV}$.
18. Set the synthesizer amplitude to the level recorded in step 8 and adjust the A14R39 -10 dB for a DMM reading of $1000 \text{ mV} \pm 1 \text{ mV}$.
19. Repeat steps 17 and 18 until no further adjustment is necessary.
20. Repeat steps 11 through 19 until the limits in Table 2-8 are met.

8. Log and Linear Amplifier

Table 2-8. Log Fidelity Check

Synthesizer Level	DMM Reading
Reference from step 8	1000 mV \pm 1 mV
Reference - 10 dB	875 mV \pm 3 mV
Reference - 20 dB	750 mV \pm 4 mV
Reference - 30 dB	625 mV \pm 4 mV
Reference - 40 dB	500 mV \pm 5 mV
Reference - 50 dB	375 mV \pm 6 mV
Reference - 60 dB	250 mV \pm 7 mV
Reference - 70 dB	125 mV \pm 8 mV

Linear Output and Step Gain Adjustments

21. Press the following spectrum analyzer keys:

AMPLITUDE 50 (-dBm)
 SCALE LOG LIN (LIN) MORE 1 of 2
 AMPTD UNITS dBm

22. Set the synthesizer amplitude to the level recorded in step 8 and adjust A14R34 LIN for a DMM reading of 1000 mV \pm 1 mV.
23. Make the adjustments indicated in Table 2-9.

Table 2-9. Linear Gain Check

Adjust	Synthesizer Level	Reference Level (dBm)	DMM Reading
A14R34	Reference from step 8	-50	1000 mV \pm 1 mV
A14R33	Reference - 10 dB	-60	1000 mV \pm 5 mV
A14R30	Reference - 20 dB	-70	1000 mV \pm 5 mV
A14R27	Reference - 30 dB	-80	1000 mV \pm 5 mV
N/A	Reference - 40 dB	-90	1000 mV \pm 30 mV

9. CAL FREQ Adjustment Routine

Description

The **CAL FREQ** softkey accesses an internal self-adjustment routine. The "CAL FREQ Adjustment Routine" adjusts the spectrum analyzer to obtain frequency accuracy using CAL OUT signal. The following adjustments are automatically performed by **CAL FREQ** routine:

- Sweep time calibration.
- YTO offset and slope.
- FM coil timing constants.
- Span attenuator.
- FM detector sensitivity.

Equipment

Cable	
BNC Cable, 20 cm (9 in)	HP 10502A
Adapter	
Adapter, Type N (m) to BNC (f)	HP 1250-0780

Adjustment Procedure

1. Connect the CAL OUT to the INPUT 50Ω with the BNC cable. See Figure 2-16.

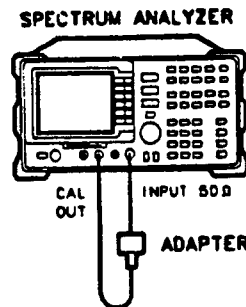

Figure 2-16. CAL FREQ Adjustment Routine Setup

2. Press the following spectrum analyzer keys:

CAL **CAL FREQ**

The **CAL FREQ** adjustment routine will take a few minutes to run.

The internal adjustment data will be stored in working RAM. To store this data in nonvolatile memory, press **CAL STORE**.

9. CAL FREQ Adjustment Routine

Note

Interrupting this routine may result in corrupt data being stored in RAM. If this occurs, rerun the **CAL FREQ** adjustment routine.

10. CAL AMPTD Adjustment Routine

Description

The **CAL AMPTD** softkey accesses an internal self-adjustment routine. The following adjustments are automatically performed by **CAL AMPTD**:

- The reference level is calibrated by adjusting the gain of the IF section.
- The 3 dB resolution bandwidths are adjusted.
- Bandwidth amplitude errors are determined. Errors are corrected with video offsets.
- Step-gain and input-attenuator errors are determined. Errors are corrected with video offsets.
- Log fidelity is checked in 1 dB steps. Errors are corrected with video offsets.

Equipment

Cable	
BNC Cable, 20 cm (9 in)	HP 10502A
Adapter	
Adapter, Type N (m) to BNC (f)	HP 1250-1476

Adjustment Procedure

Note It is recommended to complete the "CAL FREQ Adjustment Routine" prior to running the "CAL AMPTD Adjustment Routine".



1. Connect the CAL OUT to the INPUT 50Ω using a BNC cable. See Figure 2-17.

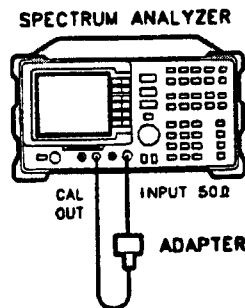

Figure 2-17. CAL AMPTD Adjustment Routine Setup

10. CAL AMPTD Adjustment Routine

2. Press the following spectrum analyzer keys:

CAL **CAL AMPTD**

The **CAL AMPTD** routine takes approximately 5 to 7 minutes to run. The internal adjustment data will be stored in working RAM. To store this data in nonvolatile memory, press **CAL STORE**.

11. CAL YTF Adjustment Routine

Description

The **CAL YTF** softkey accesses an internal adjustment routine. This routine adjusts the slope and offset of the A3A2 Switched YTF tune voltage. The comb generator is used as the source for this adjustment. The "CAL FREQ Adjustment Routine" must be performed prior to this adjustment.

Equipment

Cable

Type N (m) to SMA (m) Cable Assembly HP 8120-5148

Adjustment Procedure

1. Perform the CAL FREQ routine as indicated in the "CAL FREQ Adjustment Routine" in this chapter.
2. Connect the 100 MHz COMB OUT to INPUT 50Ω using the YTF CAL cable. Refer to Figure 2-18.

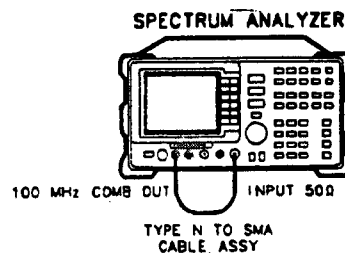

Figure 2-18. CAL YTF Adjustment Setup

3. Press the following keys:

PRESET
Hz
CAL
CAL YTF

The **CAL YTF** routine will take a few minutes to run. The message "CAL: DONE" will be displayed when the routine has finished. The internal adjustment data will be stored in working RAM.

If the message "LOST COMB SIGNAL" is displayed, perform the Mixer Bias DAC Initialization procedure.

4. Press **CAL STORE** to store the YTF correction data in nonvolatile memory.

11. CAL YTF Adjustment Routine

Mixer Bias DAC Initialization

If the message "LOST COMB SIGNAL" is displayed, the current mixer bias DAC settings may not be adequate to ensure that a comb signal is displayed.

1. Press the following keys to activate title mode:

PRESET

DISPLAY

CHANGE TITLE

2. Enter DSPBIAS; in the title at top screen, using the front-panel keys. This entry is the command for the display of the mixer bias DAC correction data.
3. Press the following keys to display the mixer bias values for frequency bands 1 through 4:

CAL

MORE 1 of 3

MORE 2 of 3

SERVICE CAL

EXECUTE TITLE

4. Record the displayed "Optimum Bias" DAC value.

Table 2-10. Acceptable Mixer Bias DAC Correction Values

Band	Optimum Bias	Acceptable Bias Range
1	_____	800 to 1900

5. If the recorded "Optimum Bias" values are within the acceptable ranges indicated in Table 2-10, RF section troubleshooting is necessary.

If the recorded "Optimum Bias" values are not within the acceptable ranges indicated in Table 2-10, complete the rest of this procedure to initialize the mixer bias DAC values.

11. CAL YTF Adjustment Routine

6. Press the following keys to allow entry of the default mixer bias DAC values:

PRESET

FREQUENCY -2001 **Hz**

DISPLAY

CHANGE TITLE

7. Enter CALMXRDATA 1600,1; as a title entry to set the mixer bias value to 1600 for band 1.
8. Press the following keys to store the mixer bias value for band 1 in nonvolatile memory:

CAL

MORE 1 of 3

MORE 2 of 3

SERVICE CAL

EXECUTE TITLE

9. Press the following keys to allow entry of the default mixer bias DAC value for band 2:

DISPLAY

CHANGE TITLE

10. Press the following keys to activate title mode:

PRESET

DISPLAY

CHANGE TITLE

11. Enter DSPBIAS; in the title at top screen.

12. Press the following keys to display the mixer bias value:

CAL

MORE 1 of 3

MORE 2 of 3

SERVICE CAL

EXECUTE TITLE

Confirm that the "Optimum Bias" DAC value displayed is 1600.

13. Repeat the CAL YTF adjustment procedure.

14. Perform the CAL MXR adjustment procedure.

12. CAL MXR Adjustment Routine

Description

The **CAL MXR** softkey accesses an internal adjustment routine which optimizes the dc bias for the A3A6 Dual Band Mixer when in high band (2.75 to 6.5 GHz). The comb generator is used as the source for this adjustment. The CAL YTF routine must be performed prior to this adjustment. New frequency response correction constants must be developed following the CAL MXR Adjustment Routine.

Equipment

Cable

Type N (m) to SMA (m) Cable Assembly HP 8120-5148

Procedure

1. Perform the CAL YTF routine as indicated in the "CAL YTF Adjustment Routine" in this chapter.
2. Connect the 100 MHz COMB OUT to INPUT 50Ω using the CAL YTF cable (Type N to SMA cable). Refer to Figure 2-19.

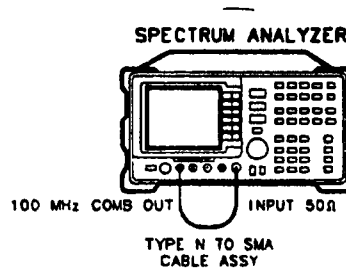

Figure 2-19. CAL MXR Adjustment Setup

3. Press the following spectrum analyzer keys:

PRESET
FREQUENCY -2001 **Hz**
CAL MORE 1 of 3 MORE 2 of 3
SERVICE CAL **CAL MXR**

Note

The frequency of -2001 Hz is necessary to access the **SERVICE CAL** routines.



12. CAL MXR Adjustment Routine

The CAL MXR routine will take a few minutes to run. The message "CAL: DONE" will be displayed when the routine has finished. The internal adjustment data will be stored in working RAM.

4. Press CAL STORE to store the correction data in nonvolatile memory.

13. Third Converter and Second IF Bandpass

Description

The 321.4 MHz, second IF bandpass filter is adjusted for maximum signal amplitude.

The CAL OUT amplitude is measured and adjusted for $-20 \text{ dBm} \pm 0.4 \text{ dB}$. The insertion loss of a low pass filter (LPF) and 10 dB attenuator are characterized. The harmonics of the CAL OUT signal are suppressed with the LPF before the amplitude accuracy is measured using a power meter.

Equipment

Test Equipment

Synthesized Sweeper	HP 8340A/B
Spectrum Analyzer	HP 8566A/B
Measuring Receiver (used as a power meter)	HP 8902A
Power Meter	HP 436A
Low Power Sensor with a 50 MHz reference attenuator	HP 8484A
Power Sensor	HP 8482A
Power Splitter	HP 11667A
10 dB Attenuator, Type N (m to f), dc-12.4 GHz Opt 010	HP 8491A
Low Pass Filter	HP 0955-0455
IF Test Board	HP 5062-6421

Cables

Type N, 152 cm (60 in)	HP 11500D
BNC Cable, 120 cm (48 in)	HP 10503A
Test Cable, SMB (f) to BNC (m) (2 required)	HP 85680-60093

Adapters

APC 3.5(f) to Type N(f)	HP 1250-1745
Type N(f) to BNC(m) (2 required)	HP 1250-1477
Type N(m) to BNC(f)	HP 1250-1476

Adjustment Procedure

Second IF Bandpass Filter Adjustment

1. Press INSTRUMENT PRESET on the HP 8566A/B and set the controls as follows:

CENTER FREQUENCY	21.4 MHz
FREQUENCY SPAN	50 MHz
REFERENCE LEVEL	-30 dBm
dB/DIV	1 dB/DIV

2. Set the synthesized sweeper controls as follows:

CW	321.4 MHz
POWER LEVEL	-26 dBm

3. Turn the spectrum analyzer **LINE** switch to OFF. Remove the instrument cover assembly. Refer to the "Instrument Cover" removal procedure in Chapter 3 of this manual.
4. Remove the first IF bandwidth filter assembly, A11.

13. Third Converter and Second IF Bandpass

5. Install the IF test board into the A11 slot.
6. Remove the W9 cable from A9J4, 321.4 MHz IF INPUT.
7. Connect the synthesized sweeper output to A9J4. Refer to Figure 2-20.

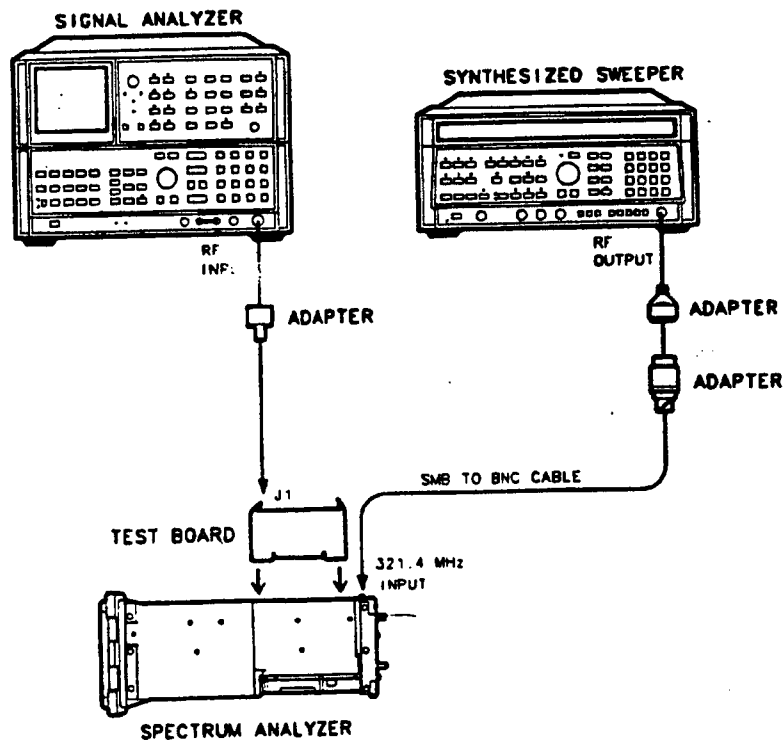

Figure 2-20. Second IF Bandpass Filter Adjustment Setup

8. Press the spectrum analyzer **LINE** switch to ON.
9. Press the following spectrum analyzer keys:
PRESET
SPAN 0 Hz
10. Connect the HP 8566A/B RF INPUT to J1 of the IF test board. Refer to Figure 2-20.
11. Adjust A9C44, A9C46, and A9C47 for maximum signal amplitude as observed on the HP 8566A/B. Adjust the reference level of the HP 8566A/B, as necessary, to display the signal below the top graticule.
12. Remove the test board from the A11 slot and install the A11 Bandwidth Filter assembly.
13. Reconnect W9 to A9J4, 321.4 MHz INPUT.

13. Third Converter and Second IF Bandpass

LPF, Attenuator and Adapter Insertion Loss Characterization

14. Zero and calibrate the HP 8902A and HP 8482A in LOG mode as described in the *HP 8902A Operation Manual*.

Caution

Do not attempt to calibrate the HP 8484A without the reference attenuator or damage to the HP 8484A will occur.

15. Zero and calibrate the HP 436A and HP 8484A, as described in the *HP 436A Operation Manual*.
16. Connect the equipment as shown in Figure 2-21. Connect the HP 8484A directly to the Power Splitter (bypass the LPF, Attenuator and Adapters).

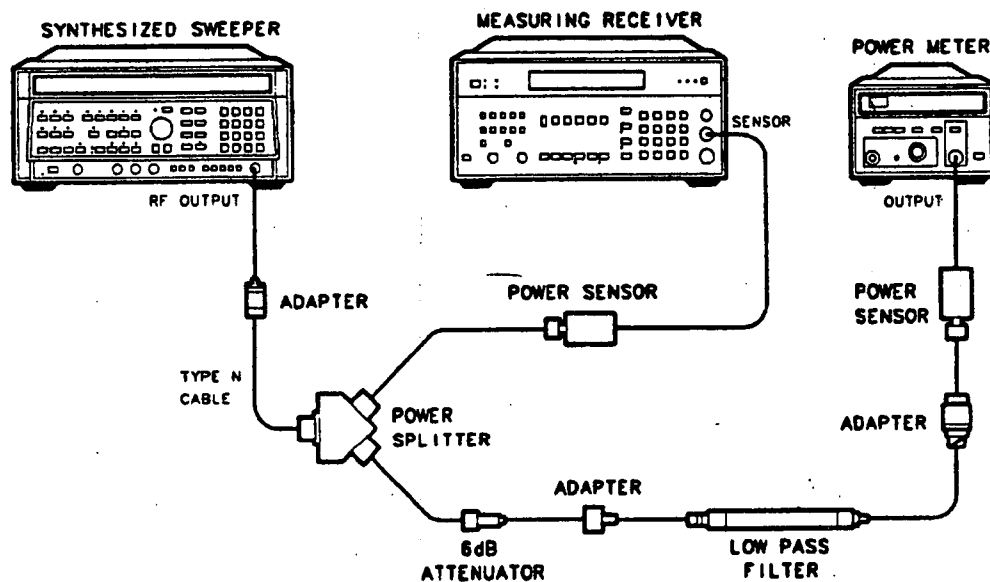

Figure 2-21. LPF Characterization

17. Press INSTRUMENT PRESET on the HP 8340A/B. Set the controls as follows:

CW	300 MHz
POWER LEVEL	-15 dBm

Note

Allow the power sensors to settle before proceeding.

18. On the HP 8902A, press RATIO mode. Power indication should be 0 dB.
19. On the HP 436A, press the dB REF mode key. Power indication should be 0 dB.

13. Third Converter and Second IF Bandpass

20. Connect the LPF, Attenuator and adapters as shown in Figure 2-21.
21. Record the HP 8902A reading in dB. This is the relative error due to mismatch.
Mismatch Error _____ dB
22. Record the HP 436A reading in dB. This is the relative uncorrected insertion loss of the LPF, attenuator, and adapters.
Uncorrected Insertion Loss _____ dB
23. Subtract the Mismatch Error (step 21) from the Uncorrected Insertion Loss (step 22). This is the corrected insertion loss.
Corrected Insertion Loss _____ dB

Example: If the Mismatch Error is +0.3 dB and the uncorrected Insertion Loss is -10.2 dB, subtract the mismatch error to the insertion loss gives a corrected reading of -10.5 dB.

300 MHz Calibrator Amplitude Adjustment

24. Connect the equipment as shown in Figure 2-22. The spectrum analyzer should be positioned so that the setup of the adapters, LPF and attenuator do not bind. It may be necessary to support the center of gravity of the devices.

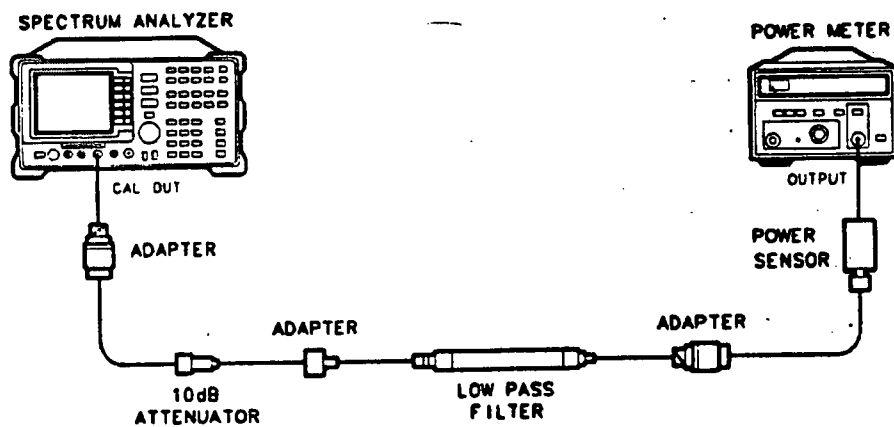

Figure 2-22. 300 MHz Calibrator Amplitude Accuracy Test Setup

25. On the HP 436A, press the dBm mode key. Record the HP 436A reading in dBm.
HP 436A Reading _____ dBm

13. Third Converter and Second IF Bandpass

26. Subtract the Corrected Insertion Loss (Step 23) from the HP 436A reading (step 25) and record as the CAL OUT power. The CAL OUT should be $-20 \text{ dBm} \pm 0.4 \text{ dB}$.

$$\text{CALOUT Power} = \text{HP 436A Reading} - \text{Corrected Insertion Loss}$$

Example: If the Corrected Insertion Loss is -10.0 dB , and the HP 8902A reading is -30 dB , then $-30 \text{ dB} - (-10.0) \text{ dB} = -20 \text{ dB}$

CAL OUT Power _____ dBm

27. Adjust A9R19 CAL OUT ADJ accordingly if the CAL OUT amplitude is not $-20 \text{ dBm} \pm 0.4 \text{ dB}$ as calculated in step 26.

14. Comb Generator

Description

The output signal from the A3A1 Comb Generator Assembly, with the Step Recovery Diode Module (SRD) disconnected, is adjusted for maximum peak-to-peak voltage. A3A1C5 FREQ is centered, and the comb generator frequency is measured with a frequency counter. If the measured frequency is not $100.000 \text{ MHz} \pm 0.0004 \text{ MHz}$, A3A1L3 is selected to bring the frequency within tolerance.

The comb generator signal is adjusted for maximum output power as measured with a measuring receiver (used as a power meter). If the amplitude is not $+26.0 \pm 0.8 \text{ dBm}$, A3A1R6 is selected to bring the amplitude within tolerance.

A3A1C5 FREQ is adjusted for a comb generator frequency of $100.000000 \text{ MHz} \pm 0.000010 \text{ MHz}$ (tolerance of $\pm 10 \text{ Hz}$).

Equipment

Test Equipment

Oscilloscope	HP 1980A/B
Frequency Counter	HP 5343A
Measuring Receiver (used as power meter)	HP 8902A
Power Sensor	HP 8482A
Attenuator, 20 dB	HP 8491B, Opt 020

Cables

SMA Cable, 90 cm (36 in.)	HP5061-5458
BMC Cable, 120 cm (48 in.)	HP 10503A

Adapters

Adapter, Type N (m) to SMA (f)	HP 1250-1250
Adapter, Type N (f) to Type N (f)	HP 1250-1472
Adapter, Type N (m) to BNC (f)	HP 1250-1476

Adjustment Procedure

1. Turn the spectrum analyzer **LINE** switch to OFF. Remove the instrument cover assembly. Refer to the Instrument Cover Removal Procedure in Chapter 3 of this manual.
2. Remove the front-end assembly. Refer to the "Front-End Assembly" removal procedure.
3. Remove the A3A1 Comb Generator assembly from the front-end assembly and place in a service position, leaving W13 connected to the A7 Analog Interface.
4. Remove W24 from the A3A1J1 comb generator output connector. Connect the SMA cable to A3A1J1. Refer to Figure 2-23.

14. Comb Generator

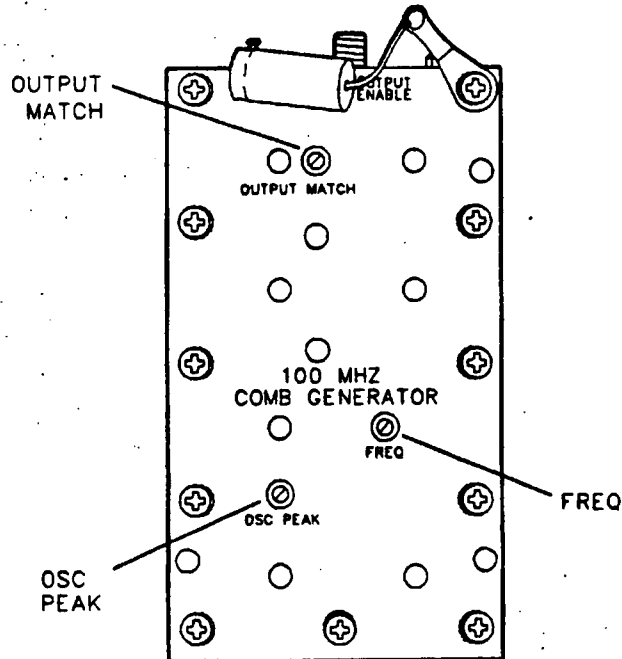

Figure 2-23. Comb Generator Adjustment Location

5. Turn the spectrum analyzer **LINE** switch to \ominus N.
6. Press the following spectrum analyzer keys:

AUX CTRL **COMB GEN ON OFF** (ON)

Frequency Adjustment

7. Connect the other end of the SMA cable to the 20 dB attenuator. Connect the output of the 20 dB attenuator to the 10 Hz to 500 MHz input of the frequency counter using adapters and the BNC cable.
8. Adjust A3A1C5 FREQ for 100.000000 MHz \pm 0.00004 MHz. Refer to Figure 2-23 for adjustment location.
9. Disconnect the BNC cable from the frequency counter and connect the BNC cable to CH1 of the oscilloscope. Set the oscilloscope controls as follows:

CH 1	ON
CH 2	OFF
CH 1 VOLTS/DIV	5 V
TIMEBASE	MAIN
CH A COUPLING	AC
SECS/DIV	50 μ S
TRIGGER	INT
TRIGGER COUPLING	AC

10. Adjust both A3A1C15 OUTPUT MATCH and A3A1C3 OSC PEAK for maximum peak-to-peak voltage on the oscilloscope display.

14. Comb Generator

11. Reconnect the BNC cable to the frequency counter input. The comb generator frequency must be $100.000000 \text{ MHz} \pm 0.00004 \text{ MHz}$.
12. Repeat steps 8 through 11 until the frequency is within specification.

Note

Perform steps 13 through 15 only if the comb generator frequency cannot be brought within tolerance with the output power peaked.

13. Set the **LINE** switch to OFF and remove the power cord. Remove the A3A1 Comb Generator cover plate.
14. Change the selected value of A3A1L3 to obtain an output frequency of $100.000500 \text{ MHz} \pm 0.004 \text{ MHz}$ with A3A1C5 FREQ centered. Increasing the value of A3A1L3 increases the output frequency of the comb generator. The frequency of the oscillator decreases about 500 Hz when the cover plate is installed. Refer to Figure 2-24 for component location.

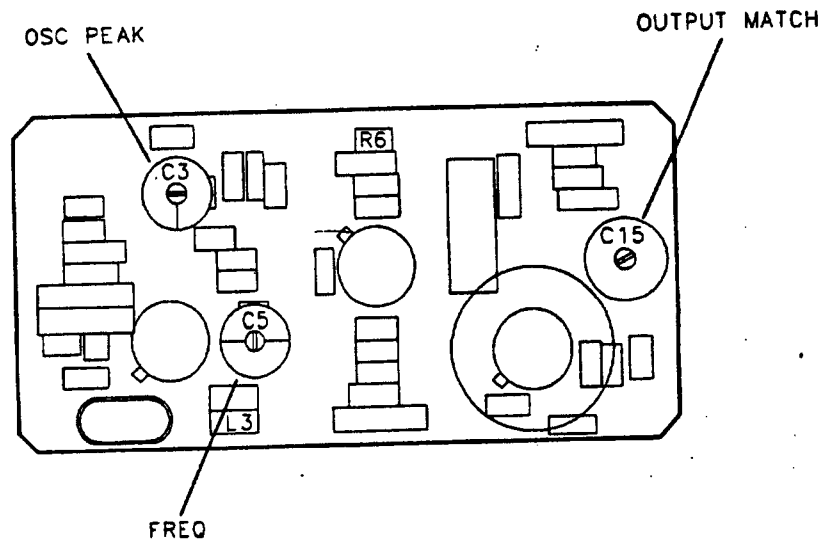

Figure 2-24. Comb Generator Component Location

15. Each time the value of A3A1L3 is changed, reconnect the power cord, set the **LINE** switch to ON, and adjust A3A1C3 OSC PEAK for maximum signal. The output frequency changes when A3A1C3 OSC PEAK is adjusted. Reinstall the comb generator cover plate and repeat steps 8 through 12.

14. Comb Generator

Output Power

16. Zero and calibrate the power sensor/measuring receiver combination in log mode (power reads out in dBm). Enter the power sensor 0.1 GHz cal factor into the measuring receiver.
17. Connect the power sensor to the output of the 20 dB attenuator using an adapter.
18. Adjust A3A1C15 OUTPUT MATCH for maximum power output. The measuring receiver should measure +6 dBm \pm 0.8 dB.

Note

Perform steps 19 through 21 only if the output power of the comb generator is out of tolerance.



-
19. Set the **LINE** switch to OFF, remove the power cord, and remove the A3A1 Comb Generator cover plate.
 20. Change the selected value of A3A1R6 to obtain an output power reading of +6.0 dBm \pm 0.8 dB. Increasing the value of A3A1R6 decreases the output power of the comb generator, while decreasing the value increases the output power. Refer to Figure 2-24 for component location.
 21. Each time the value of A3A1R6 is changed, reconnect the power cord, set the **LINE** switch to ON, and adjust A3A1C16 OUTPUT MATCH for maximum power out.
 22. Reinstall the comb generator assembly cover plate and all the screws. Connect a BNC cable from the 20 dB attenuator to the frequency counter input using adapters.
 23. Adjust A3A1C5 FREQ for a frequency counter reading of 100.000000 MHz \pm 0.000010 MHz (tolerance of \pm 10 Hz).
 24. Set the **LINE** switch to OFF and reconnect W24 to A3A1J1.
 25. Reinstall A3A1 Comb Generator Assembly into RF Section. Refer to the A3A1 Comb Generator Assembly Replacement Procedure.
 26. Reinstall the front-end assembly in the spectrum analyzer. Refer to the "Front-End Assembly" replacement procedure.

15. Frequency Response

Description

The frequency response (flatness) of the spectrum analyzer is measured with corrections off. The flatness data is then entered into the spectrum analyzer using the **SERVICE CAL** functions. The error corrections are stored in battery backed RAM on the A16 Processor/Video Assembly.

Equipment

Test Equipment

Synthesized Sweeper	HP 8340A/B
Measuring Receiver (used as a power meter)	HP 8902A
Power Sensor	HP 8485A
Power Sensor	HP 8482A
Power Splitter	HP 11667B

Adapters

Type N(m) to APC 3.5(m)	HP 1250-1743
Type N(f) to APC 3.5(m)	HP 1250-1750
APC 3.5(f) to APC 3.5(f)	HP 5061-5311

Cable

APC 3.5, 91 cm (36 in.)	HP 8120-4921
-------------------------------	--------------

Adjustment Procedure

Measuring Uncorrected Flatness

1. Zero and calibrate the measuring receiver and sensor LOG mode as described in the *HP 8902A Operation Manual*.
2. Connect the equipment as shown in Figure 2-25.
3. Press INSTRUMENT PRESET on the synthesized sweeper. Set the synthesized sweeper controls as follows:

CW	300 MHz
FREQ STEP	72 MHz
POWER LEVEL	-3 dBm

4. To enter band 0, press the following spectrum analyzer keys:

15. Frequency Response

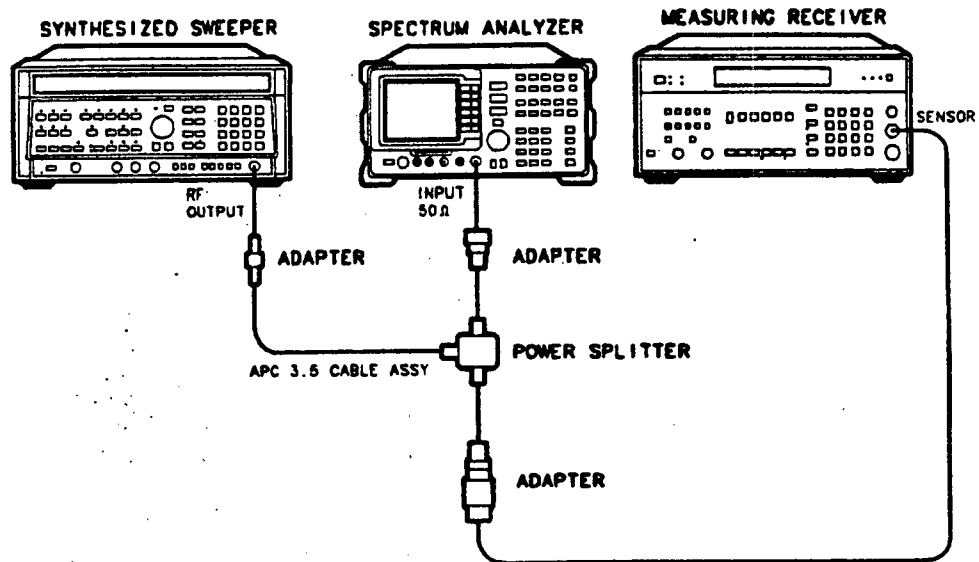

Figure 2-25. Frequency Response Setup

PRESET

CAL MORE 1 of 3

CORRECT ON OFF (OFF)

SPAN BAND LOCK 0 - 2.9 GHz BAND 0

5. Set the spectrum analyzer controls by pressing the following keys:

FREQUENCY 300 (MHz)

CF STEP AUTO MAN (MAN) 72 (MHz)

SPAN 5 (MHz)

AMPLITUDE 0 (dBm)

SCALE LOG LIN (LOG) 10 (dB)

BW 1 (MHz)

PEAK SEARCH

SIGNAL TRACK (ON)

6. Adjust the synthesized sweeper POWER LEVEL for a MKR-TRK amplitude reading of $-9 \text{ dBm} \pm 0.1 \text{ dB}$ on the spectrum analyzer.
7. Press RATIO on the measuring receiver.

Band 0

8. Set the synthesized sweeper CW to 12 MHz.

9. Press the following spectrum analyzer keys:

FREQUENCY 12 **MHz**

10. Adjust the synthesized sweeper POWER LEVEL for a MKR-TRK amplitude reading of $-9 \text{ dBm} \pm 0.1 \text{ dB}$ on the spectrum analyzer.

11. Record the power ratio displayed on the measuring receiver in Column 2 of Table 2-11.

12. On the synthesized sweeper, press CW and STEP UP.

13. On the spectrum analyzer, press the following keys:

MKR **MARKERS OFF**

FREQUENCY **↑**

PEAK SEARCH

SIGNAL TRACK (ON)

14. Step through the remaining frequencies listed in Table 2-11. At each new frequency, repeat steps 10 through 13 and enter the appropriate power sensor cal factor into the measuring receiver as listed in Column 3 of Table 2-11.

Band 1

15. Replace the HP 8482A Power Sensor with the HP 8485A Power Sensor.

16. Calibrate the measuring receiver and HP 8485A power sensor combination in log mode.

17. Set the synthesized sweeper to 300 MHz.

18. Press the following spectrum analyzer keys:

FREQUENCY 300 **MHz**

PEAK SEARCH

SIGNAL TRACK (ON)

19. Adjust the synthesized sweeper POWER LEVEL for a MKR-TRK amplitude reading of $-9 \text{ dBm} \pm 0.1 \text{ dB}$ on the spectrum analyzer.

20. Press RATIO on the measuring receiver.

21. To enter band 1, press the following spectrum analyzer keys:

MKR **MARKERS OFF**

SPAN **BAND LOCK 2.75 - 6.5 BAND 1**

22. Set the spectrum analyzer controls by pressing the following keys:

FREQUENCY 2.75 **GHz**

CF STEP AUTO MAN. (MAN) 234.9 **MHz**

SPAN 5 **MHz**

BW 1 **MHz**

23. Set the synthesized sweeper CW to 2.75 GHz and FREQ STEP to 234.9 MHz.

24. Press the following spectrum analyzer keys:

15. Frequency Response

PEAK SEARCH

SIGNAL TRACK (ON)

AMPLITUDE **PRESEL PEAK**

25. Adjust the synthesized sweeper POWER LEVEL for a MKR-TRK amplitude reading of $-9 \text{ dBm} \pm 0.1 \text{ dB}$ on the spectrum analyzer.
26. Record the power ratio displayed on the measuring receiver in Column 2 of Table 2-12.
27. On the synthesized sweeper, press CW and STEP UP.
28. On the spectrum analyzer, press the following keys:

MKR **MARKERS OFF**

FREQUENCY **(↑)**

29. Step through the remaining frequencies listed in Table 2-12. At each new frequency, repeat steps 24 through 28 and enter the appropriate power sensor cal factor into the measuring receiver as listed in Column 3 of Table 2-12.

Entering Flatness Correction Data

30. Enter the passcode by pressing the following spectrum analyzer keys:

PRESET

FREQUENCY -2001 **Hz**

31. To access the flatness correction menu, press the following spectrum analyzer keys:

CAL **MORE 1 of 3** **MORE 2 of 3**

SERVICE CAL

FLATNESS DATA

Note



Perform the next step *only if* all the flatness correction data must be replaced in memory due to the repair or replacement of the A16 Processor/Video assembly.

32. To initialize the area of memory where the flatness correction data is stored, press the following keys:

INIT FLT

PRESET

FREQUENCY -2001 **Hz**

CAL **MORE 1 of 3** **MORE 2 of 3**

SERVICE CAL

FLATNESS DATA

33. To enter flatness corrections, press **EDIT FLATNESS**.
34. The frequency of the first data point, 12.00 MHz, will be displayed in the active function block of the spectrum analyzer display.
35. Use the data keys on the spectrum analyzer to enter the amplitude value for 12 MHz from Column 2 of Table 2-11, Frequency Response Errors. Terminate the entry with the **dB**

15. Frequency Response

key. When entering negative amplitude values, precede the numeric entry with the \ominus and dB keys or the $\ominus\text{dB}$ key.

Each entry is displayed briefly before the data-entry routine steps to the next data point.

Note



The BK SP (backspace) key may be used to correct any entry if the terminator, dB or $\ominus\text{dB}$ key has *not* been pressed. Re-enter the data if the terminator has been pressed.

-
36. Press \uparrow (step up) and enter the data from Column 2 of the "Frequency Response Errors" tables for the next data point as described in step 34.
 37. Repeat step 35 for the remaining flatness correction data points listed in the "Frequency Response Errors" tables.

Note



At each point, verify that the frequency listed in the active function block corresponds to the frequency at which the data was taken. If these two frequencies do not correspond, press \uparrow (step up) or \downarrow (step down) until the proper frequency is displayed in the active function block.

If some data is incorrect after entering all of the data from the "Frequency Response Errors" tables, select the incorrect data point using \uparrow (step up) or \downarrow (step down) and re-enter the proper data.

-
38. After all corrections have been input, press **STORE FLATNESS** to store the correction data in nonvolatile memory. The instrument will automatically preset and display CAL: DONE in the active function block of the spectrum analyzer.

15. Frequency Response

Table 2-11. Frequency Response Errors Band 0

Column 1 Frequency (GHz)	Column 2 HP 8902A Reading (dB)	Column 3 CAL FACTOR Frequency (GHz)
0.012	_____	0.05
0.084	_____	0.05
0.156	_____	0.05
0.228	_____	0.05
0.300	_____	0.05
0.372	_____	0.05
0.444	_____	0.05
0.516	_____	0.05
0.588	_____	0.05
0.660	_____	0.05
0.732	_____	0.05
0.804	_____	0.05
0.876	_____	0.05
0.948	_____	0.05
1.020	_____	0.05
1.092	_____	2.0
1.164	_____	2.0
1.236	_____	2.0
1.308	_____	2.0
1.380	_____	2.0
1.452	_____	2.0
1.524	_____	2.0
1.596	_____	2.0
1.668	_____	2.0
1.740	_____	2.0
1.812	_____	2.0
1.884	_____	2.0

Table 2-11. Frequency Response Errors Band 0 (continued)

Column 1 Frequency (GHz)	Column 2 HP 8902A Reading (dB)	Column 3 CAL FACTOR Frequency (GHz)
1.956	_____	2.0
2.028	_____	2.0
2.100	_____	2.0
2.172	_____	2.0
2.244	_____	2.0
2.316	_____	2.0
2.388	_____	2.0
2.460	_____	2.0
2.532	_____	3.0
2.604	_____	3.0
2.676	_____	3.0
2.748	_____	3.0
2.820	_____	3.0
2.892	_____	3.0

15. Frequency Response

Table 2-12. Frequency Response Errors Band 1

Column 1 Frequency (GHz)	Column 2 HP 8902A Reading (dB)	Column 3 CAL FACTOR Frequency (GHz)
2.7500	_____	3.0
2.9849	_____	3.0
3.2198	_____	3.0
3.4547	_____	3.0
3.6896	_____	4.0
3.9245	_____	4.0
4.1594	_____	4.0
4.3943	_____	4.0
4.6292	_____	5.0
4.8641	_____	5.0
5.0990	_____	5.0
5.3339	_____	5.0
5.5688	_____	5.0
5.8037	_____	6.0
6.0386	_____	6.0
6.2735	_____	6.0
6.5084	_____	6.0

16. Time and Date

Description

The time and date are displayed in the top left corner of the display when the timedate mode is activated. The time and date are changed using the front-panel keys.

Adjustment Procedure

1. To turn the time and date ON or OFF, press the following spectrum analyzer keys:

CONFIG

TIMEDATE

TIMEDATE ON OFF (ON) or (OFF) as desired

The time and date will be displayed in the top-left corner with ON underlined.

2. The time and date may be displayed as month, day, and year (MDY) or as day, month, and year (DMY). To change the display, press the following spectrum analyzer keys:

CONFIG

TIMEDATE

DATEMODE MDY DMY (MDY) or (DMY) as desired

3. To change the date, press the following spectrum analyzer keys:

CONFIG

TIMEDATE

SET DATE

The active function block of the spectrum analyzer will display YYMMDD (year, month, and day). Use the data keys on the spectrum analyzer to enter the correct date as YYMMDD. Terminate the entry with one of the **ENTER** data keys.

4. To change the time, press the following spectrum analyzer keys:

CONFIG

TIMEDATE

SET TIME

The active function block of the spectrum analyzer will display HHMMSS (hours, minutes, and seconds). Use the data keys on the spectrum analyzer to enter the correct time as HHMMSS. Terminate the entry with one of the **ENTER** data keys.

17. First LO Distribution Amplifier Adjustment (Option 009, 010)

Assembly Adjusted

A10 Tracking Generator Control assembly

Related Performance Test

There is no related performance test.

Description

The gate bias for the A3A14 LO Distribution Amplifier assembly is adjusted to the value specified on a label on the RF section. The LO power is adjusted so that the LO SENSE voltage is equal to the value specified on the label. The adjustments are made on the A10 Tracking Generator Control assembly, which is located in the card cage.

Equipment

Measuring Receiver	HP 8902A
Digital Voltmeter	HP 3456A
Power Sensor	HP 8485A
DVM Test Leads	HP 34118

Adapters

Dual Banana Plug	1251-2816
------------------------	-----------

Procedure

1. Set the spectrum analyzer **LINE** switch to off, then disconnect the line cord. Remove the cover assembly, then reconnect the line cord.
2. Remove the 50 Ω termination from the spectrum-analyzer rear-panel LO OUTPUT connector.
3. Connect the positive DVM test lead to A10TP5, GB (gate bias). Connect the negative DVM test lead to A10TP2, AGND (analog ground). See Figure 2-26.
4. Set the digital voltmeter controls as follows:

FUNCTION	DC VOLTS
RANGE	10 V
RESOLUTION	1 mV
5. Set the spectrum analyzer **LINE** switch to on.
6. Adjust A10R29 (GATE) for a digital voltmeter reading within 5 mV of the GATE (gate bias) voltage printed on the RF section label.
7. Zero and calibrate the measuring receiver and power sensor in LOG mode. (Power levels read in dBm.) Enter the power sensor's 5 GHz cal factor into the measuring receiver.
8. Connect the power sensor to the spectrum analyzer's LO OUTPUT.
9. On the spectrum analyzer, press **PRESET**, **SPAN**, **ZERO SPAN**, **FREQUENCY**, 4.6786, **GHz**.

17. First LO Distribution Amplifier Adjustment (Option 009, 010)

10. Connect the positive DVM test lead to A10TP4, LOS (LO sense).
11. Note the SENS (LO sense) voltage printed on the RF section label. Adjust A10R25, LO PWR (LO power) until the DVM reads equal to the SENS voltage printed on the RF section label.
12. Check that the measuring receiver power level reads greater than +12 dBm.
13. Disconnect the power sensor from LO OUTPUT, then reconnect the 50 Ω termination to LO OUTPUT.
14. Disconnect the DVM leads from A10TP4 and A10TP2.

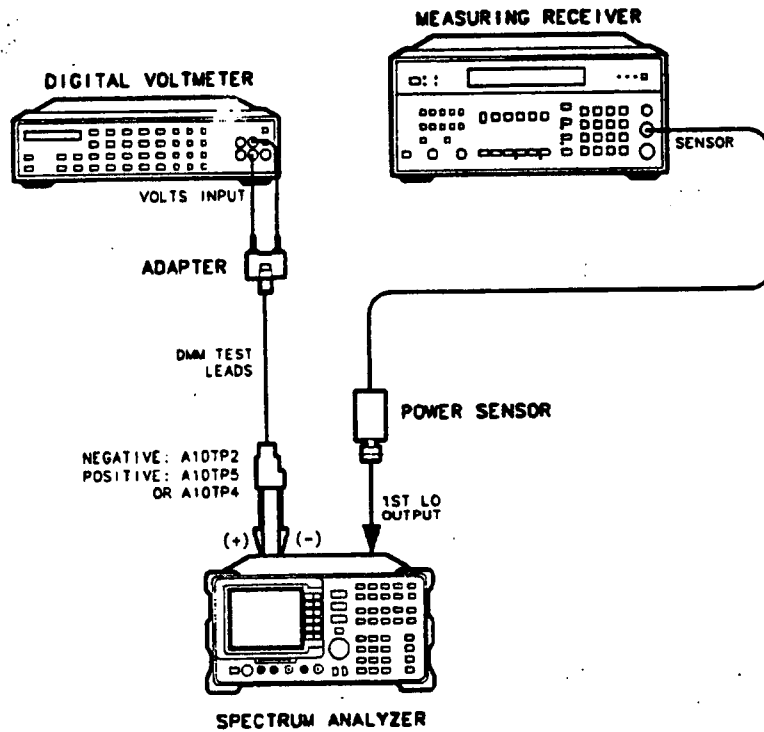

Figure 2-26. First LO Distribution Amplifier Adjustment Setup

18. BITG Power Level Adjustments (Option 010)

Assembly Adjusted

A3A15 Built-In Tracking Generator (BITG) assembly

Related Performance Test

Absolute Amplitude and Vernier Accuracy

Description

The BITG has two adjustments for setting the output power. The -10 dB ADJ (A3A15R13) sets the power level when the source power level is set to -10 dBm, and the 0 dB ADJ (A3A15R18) sets the power level when the source power level is set to 0 dBm. The -10 dB ADJ acts as an offset adjustment, while 0 dB ADJ acts as a gain adjustment.

These adjustments are set in the factory for a 10 dB difference in output power between the -10 dBm and 0 dBm source power level settings. When installing a replacement BITG, it should only be necessary to adjust -10 dB ADJ (the offset adjustment) to account for variations in cable loss from the BITG to the RF OUT 50Ω connector. This adjustment is done at a 0 dBm source power level setting. This ensures that the absolute power level with a 0 dBm source power level setting is 0 dBm, with little or no effect on the vernier accuracy.

In some cases, the power level at the -10 dBm source power level setting might be out of tolerance. In such cases, the -10 dB ADJ is set at a source power level setting of -10 dBm and the 0 dB ADJ is set at a source power level setting of 0 dBm. These two adjustments must be repeated until the power level at the two settings are within the given tolerances.

Equipment

Measuring Receiver HP 8902A
Power Sensor HP 8482A

Cable

Type N, 62 cm (24 in.) HP 11500B/C

Procedure

1. Set the spectrum analyzer **LINE** switch to off. Disconnect the line cord. Remove the cover assembly, then reconnect the line cord.
2. Connect the cable between the RF OUT 50Ω and INPUT 50Ω connectors on the spectrum analyzer.
3. Press **PRESET** on the spectrum analyzer and set the controls as follows:
CENTER FREQ 300 MHz
SPAN 0 Hz
4. On the spectrum analyzer, press the following keys:

BW 10 **kHz**

AUX CTRL **TRACK GEN** **SRC PWR ON OFF** (ON) 10 **-dBm**

18. BITG Power Level Adjustments (Option 010)

5. On the spectrum analyzer, press **TRACKING PEAK**. Wait for the **PEAKING** message to disappear.
6. Zero and calibrate the measuring-receiver/power-sensor combination in log mode (power levels readout in dBm). Enter the power sensor's 300 MHz cal factor into the measuring receiver.
7. Disconnect the cable from the RF OUT 50Ω connector, then connect the power sensor to the RF OUT 50Ω connector. See Figure 2-27.

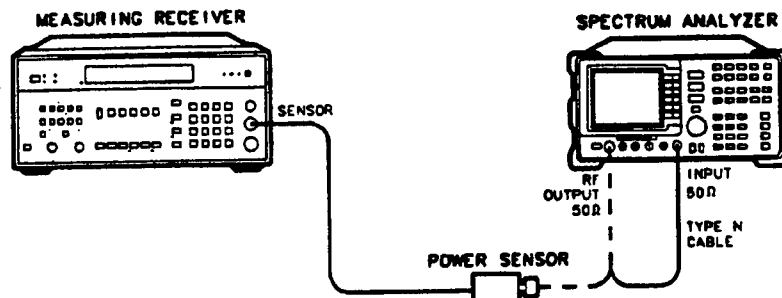

Figure 2-27. BITG Power Level Adjustment Setup

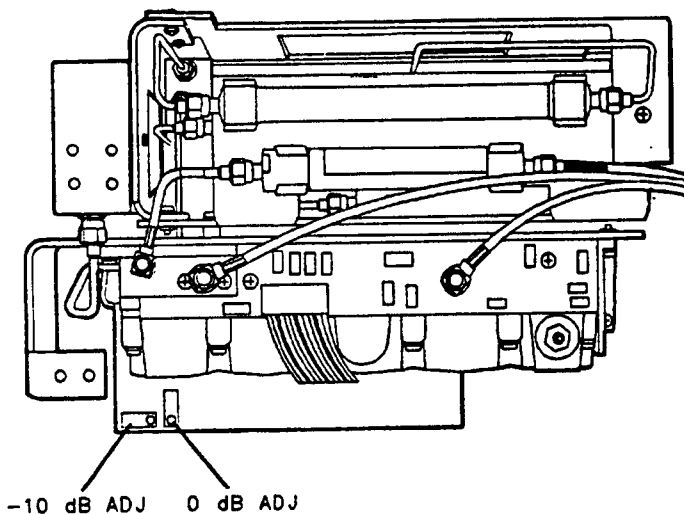

Figure 2-28. BITG Power Level Adjustment Locations

8. On the spectrum analyzer, press **SRC PWR ON OFF** (ON), 0, **dBm**, **SGL SWP**.

Note



Some spectrum analyzers may have sealing compound over A3A15R13 (-10 dB ADJ) and A3A15R18 (0 dB ADJ) adjustments. Remove this compound before making these adjustments.

9. Adjust -10 dB ADJ (A3A15R13) for a 0 dBm ± 0.05 dB reading on the measuring receiver. Refer to Figure 2-28 for adjustment location.

18. BITG Power Level Adjustments (Option 010)

10. Set the SRC PWR level to -10 dBm. Note the power displayed on the measuring receiver.

If the power level is -9.77 dBm to -10.23 dBm, then the adjustment is complete. If the power level is not within the range, then continue with steps 11 through 13.

Power at -10 dBm Setting _____ dBm

Note



The next steps should be performed *only* if the power level noted in step 10 was outside the range of -10 dBm ± 0.23 dB.

11. With the SRC PWR level set to -10 dBm, adjust -10 dB ADJ (A3A15R13) for a -10 dBm ± 0.1 dB reading on the measuring receiver. Refer to Figure 2-28 for adjustment location.
12. Set the SRC PWR level to 0 dBm. Adjust 0 dB ADJ (A3A15R18) for a 0 dBm ± 0.2 dB reading on the measuring receiver. Refer to Figure 2-28 for adjustment location.
13. Repeat steps 11 and 12 until the output power level is within the tolerances indicated at both the -10 dBm and 0 dBm SRC PWR level settings. Adjust -10 dB ADJ only with the SRC POWER level set to -10 dBm, and adjust 0 dB ADJ only with the SRC PWR level set to 0 dBm.

19. Tracking Oscillator Adjustment (Option 010)

Note

This is *not* a routine adjustment. This adjustment should only be performed if the range of either the automatic tracking peak adjustment (**TRACKING PEAK**) or the manual tracking peak adjustment (**MAN TRK ADJUST**) is insufficient to peak a signal.

Assembly Adjusted

A10 Tracking Generator assembly

Related Performance Test

There is no related performance test.

Description

The centering of the tracking oscillator range is adjusted in the factory to ensure that the tracking adjustment will work properly. Over a period of 5 years, however, the center frequency of the tracking oscillator range may drift outside of acceptable limits.

The tracking oscillator range is checked first. A tracking peak test is performed and the output frequency is recorded. Then the manual tracking adjustment is set to its minimum and maximum values and the output frequency is recorded. The minimum and maximum frequencies are compared to the peaked frequency. If the difference is less than 5 kHz, adjustment is necessary.

The adjustment recenters the tracking oscillator range. The A3 RF assembly is placed in its service position to perform this adjustment. A frequency counter is used to measure the output frequency.

Equipment

Microwave Frequency Counter	HP 5343A
50 Ω Termination	1810-0118
Alignment Tool, Non-Metallic	8710-0033

Cables

BNC, 122 cm (48 in.) (2 required)	HP 10503A
---	-----------

Adapters

Type N (f) to APC-3.5 (f)	1250-1745
Type N (m) to BNC (f)	1250-1476

19. Tracking Oscillator Adjustment (Option 010)

Procedure

Frequency Tracking Range Check

1. Connect a cable between the RF OUT 50Ω and INPUT 50Ω connectors on the spectrum analyzer.
2. Remove the rear-panel jumper that is between the 10 MHz REF OUTPUT and EXT REF IN jacks. Connect the frequency counter FREQ STD OUT connector to the spectrum analyzer EXT REF IN connector as shown in Figure 2-29.

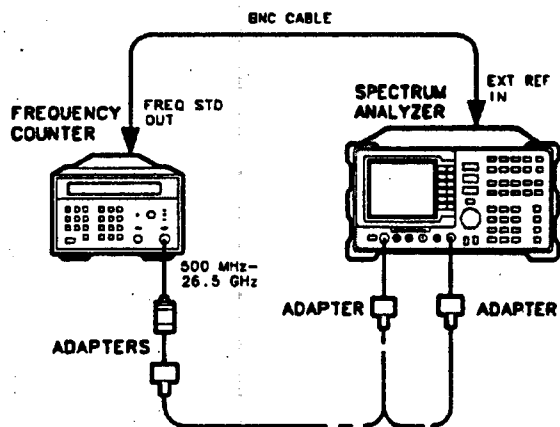

Figure 2-29. Frequency Tracking Range Setup

3. Press **PRESET** on the spectrum analyzer, then set the controls as follows:

CENTER FREQ	500 MHz
SPAN	0 Hz
4. On the spectrum analyzer, press the following key:

BW 10 kHz
AUX CTRL TRACK GEN SRC PWR ON OFF (ON) 5 -dBm
5. On the spectrum analyzer press **TRACKING PEAK**. Wait for the **PEAKING** message to disappear.
6. Set the microwave frequency counter controls as follows:

SAMPLE RATE	Midrange
10 Hz-500 MHz/500 MHz-26.5 GHz Switch	500 MHz - 26.5 GHz
RESOLUTION	1 Hz
7. Connect the RF OUT 50Ω connector to the microwave frequency counter input as shown in Figure 2-29.
8. Wait for the microwave frequency counter to gate two or three times, then record the microwave frequency counter reading below as the peaked frequency:

Peaked Frequency: _____ MHz

19. Tracking Oscillator Adjustment (Option 010)

9. On the spectrum analyzer, press **MAN TRK ADJUST**, 4095, **ENTER**. Wait for the microwave frequency counter to gate two or three times, then record the microwave frequency counter reading below as the minimum frequency:

Minimum Frequency: _____ MHz

10. On the spectrum analyzer, press **MAN TRK ADJUST**, 0, **ENTER**. Wait for the microwave frequency counter to gate two or three times, then record the microwave frequency counter reading below as the maximum frequency:

Maximum Frequency: _____ MHz

11. If the absolute value of the difference between either the minimum or maximum frequency and the peaked frequency is less than 5 kHz, proceed with the adjustment procedure below. If the differences are greater than 5 kHz, no adjustment is necessary.
12. Disconnect the cable from the **EXT REF IN** connector, then replace the rear-panel jumper.

Adjustment Procedure

13. Remove the A3 RF Section assembly as described in Chapter 3 of this supplement. With A3 sitting on top of the A2 Display assembly, reconnect all cables from A3 to their respective jacks on A7, A9, A25, and A10. Reconnect W40 to A3A15J8. Connect the 50Ω termination to the end of W42.
14. Connect the equipment as shown in Figure 2-30. The microwave frequency counter provides the frequency reference for the spectrum analyzer.

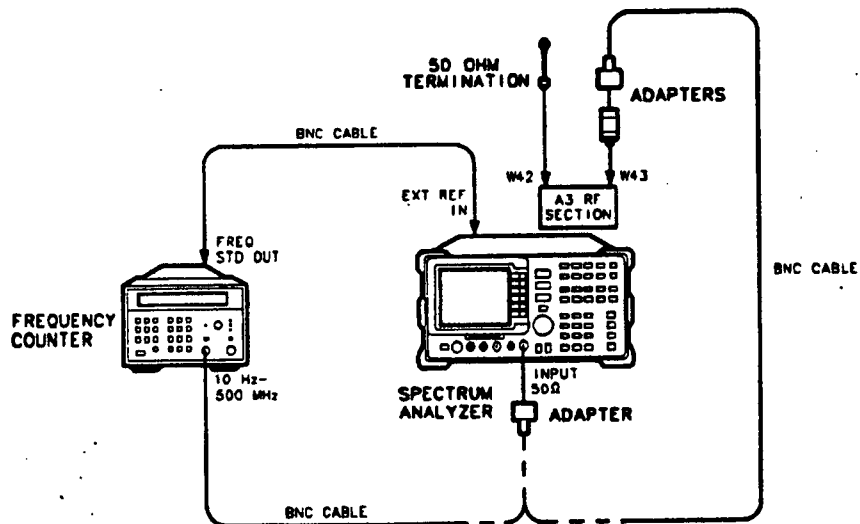

Figure 2-30. Tracking Oscillator Adjustment Setup

19. Tracking Oscillator Adjustment (Option 010)

15. Set the spectrum analyzer **(LINE)** switch to on. Press **(AUX CTRL)**, **TRACK GEN**, **SRC PWR ON OFF (ON)**. Allow the spectrum analyzer to warm up for at least 5 minutes. Set the controls as follows:

CENTER FREQ 300 MHz
SPAN 0 Hz

16. Set the microwave frequency counter controls as follows:

SAMPLE RATE Fully CCW
10 Hz-500 MHz/500 MHz-26.5 GHz Switch 10 Hz-500 MHz
50Ω - 1 MΩ Switch 50Ω

17. Remove the screw, located on the front of the tracking generator, used to seal the tracking oscillator adjustment.

18. On the spectrum analyzer, press **(AUX CTRL)**, **TRACK GEN**, **MAN TRK ADJUST**, 0, **(Hz)**.

19. Record the microwave frequency counter reading in Table 2-13 as F1.

20. On the spectrum analyzer, press **MAN TRK ADJUST**, 4095, **(Hz)**.

21. Record the microwave frequency counter reading in Table 2-13 as F2.

22. Calculate Fcenter as shown below, and record it in Table 2-13.

$$F_{center} = (F1 + F2)/2$$

23. Set SRC TRACK ADJ to 350. This sets the tracking oscillator near the center of its frequency range. (The relationship between the SRC TRACK ADJ DAC number and the output frequency is nonlinear.) Adjust SRC TRACK ADJ until the microwave frequency counter reads Fcenter ±100 Hz.

24. Record the value of SRC TRACK ADJ in Table 2-13.

Note

A3A15C3 (TRK OSC CTR) is rated for a maximum of 10 adjustment cycles. Due to this limitation, adjust TRK OSC CTR only when absolutely necessary.

25. Adjust A3A15C3 (TRK OSC CTR) until the microwave frequency counter reads 300 MHz ±500 Hz.

26. Repeat steps 17 through 24 at least once more until no further adjustment of A3A15C3 is necessary.

27. Set the spectrum analyzer **(LINE)** switch to off, then replace the screw removed in step 17.

28. Reinstall the A3 RF Section assembly into the spectrum analyzer.

29. Replace the rear-panel jumper between the 10 MHz REF OUTPUT and EXT REF IN connectors.

19. Tracking Oscillator Adjustment (Option 010)

Table 2-13. Tracking Oscillator Range Centering

N	F1 (MHz)	F2 (MHz)	Fcenter (MHz)	SRC TRACK ADJ Setting
1				
2				
3				
4				
5				
6				

Replacement Procedures

Introduction

The procedures in this chapter describe the removal and replacement of major assemblies in the HP 8595A Spectrum Analyzer.

The words "right" and "left" are used throughout these procedures to indicate the sides of the analyzer as normally viewed from the front of the instrument. Numbers in parentheses, for example (1), indicate numerical callouts on the figures.

If one or more analyzer assemblies have been replaced, related adjustments and performance verification tests should be done. Refer to the "Adjustments and Tests for Replaced or Repaired Assemblies" table in Chapter 6 of this manual for the related adjustments and performance verification tests required for each assembly.

Before You Start

There are three things you must do *before* you begin the replacement procedures in this chapter:

- Familiarize yourself with the safety symbols marked on the spectrum analyzer, and read the general safety instructions and the symbol definitions given in the front of this manual.
- The spectrum analyzer contains electrostatic sensitive components. Read the section entitled "Protection From Electrostatic Discharge" in Chapter 1 of this manual.
- Refer to Tables 1-5 and 1-6 for service tools required to complete these replacement procedures.

Removal and Replacement Procedures in this Chapter

Instrument Cover

A1 Front-Frame Assembly

A1A1 Keyboard/Front-Panel Keys

A2 Display

Before Replacing the A3 Front-End Assembly

A3A3 Low-Pass and A3A9 Bandpass Filters

A3 Front-End Assembly

FL1 Low-Pass Filter

A3A1 Comb Generator

A3A2 Switched YTF

A3A4 Second Converter

A3A5 Attenuator/DC Block

A3A6 Dual Mixer

A3A7 YTO

A3A10 Directional Coupler

A3A13 Isolator

A3A14 First LO Distribution Amplifier (Option 009, 010)

A3A15 Tracking Generator (Option 010)

A7 Analog Assembly

A8 Power Supply

A15 Motherboard and IF Extrusion

A16 Processor/Video Board Assembly

A16 Processor/Video Board Firmware ROMs

A17 Memory Card Reader

B1 Fan

BT101 Battery

Rear-Frame Assembly

Instrument Cover

Removal

1. Disconnect the analyzer from ac power.

Caution



To prevent damage to the front frame, use a soft cloth or towel between the work surface and the front frame.

-
2. Carefully place the analyzer on the work surface with the front frame facing down.
 3. Remove the four screws and washers attaching the instrument cover to the rear frame.
 4. Unscrew, but do not remove, the four rear-feet screws, using a 4 mm hex wrench.
 5. Pull the instrument cover off towards the rear of the instrument.

Replacement

1. Disconnect the analyzer from ac power.

Caution



To prevent damage when replacing the instrument cover, remember the following:

- Place a soft cloth or towel between the work surface and the front frame.
- Ensure that cables do not bind between the instrument cover and its internal assemblies.

-
2. Carefully place the analyzer on the work surface with the front frame facing down.
 3. Replace the instrument cover assembly by matching the seam on the cover with the bottom of the instrument.
 4. Fit the leading edge of the cover completely into the slot on the back of the front-frame assembly. The cover should fit snugly against the EMI gasket in the slot.
 5. Tighten the four rear-feet screws with a 4 mm hex wrench.
 6. Replace the four screws and washers attaching the instrument cover assembly to the rear frame.

A1 Front-Frame Assembly

Caution Use ESD precautions when performing this replacement procedure.



Removal

1. Remove the instrument cover assembly. Refer to the "Instrument Cover" removal procedure.
2. Place the analyzer with the bottom side facing up on the work surface.
3. Remove the A17 Memory Card Reader. Refer to the "A17 Memory Card Reader" removal procedure.
4. Remove the two screws (1) that secure the front frame to the main chassis. See Figure 3-1.
5. Remove the cable tie (2) that secures the A3A11 and A3A12 assemblies to the W10 semirigid cable.
6. Disconnect the W37 semirigid cable (3) from the 100 MHz COMB OUT connector on the front-frame assembly.
7. Disconnect the W10 semirigid cable (4) from the INPUT 50Ω connector.

Note



If the instrument came equipped with an A3A15 Tracking Generator (Option 010), disconnect the W43 semirigid cable (5) from the RF OUT 50Ω connector on the front-frame assembly.

-
8. Disconnect W3 (6) from A1R1, the front-panel INTEN control.

Note



If the instrument came equipped with an A102 AM/FM Speaker and TV Synch Trigger (Option 102) or A103 Quasi Peak Detector (Option 103), disconnect W102 from the VOL control wiring connector at A1R1.

-
9. Disconnect W1 (7) from A16J9.
 10. Place the analyzer with the front frame forward and the top side facing up on the work surface.
 11. Disconnect W7 from A9J2.
 12. Remove the five screws (8) that secure the front frame to the main chassis sides. There are three screws on the right and two screws on the left.

Caution



To prevent damage to W10, make sure it is completely disconnected from the input connector *before* removing the front frame.

13. Separate the front frame from the main chassis and disconnect the W4 ribbon cable from the A1A1 Keyboard assembly.
14. Remove the front-frame assembly.

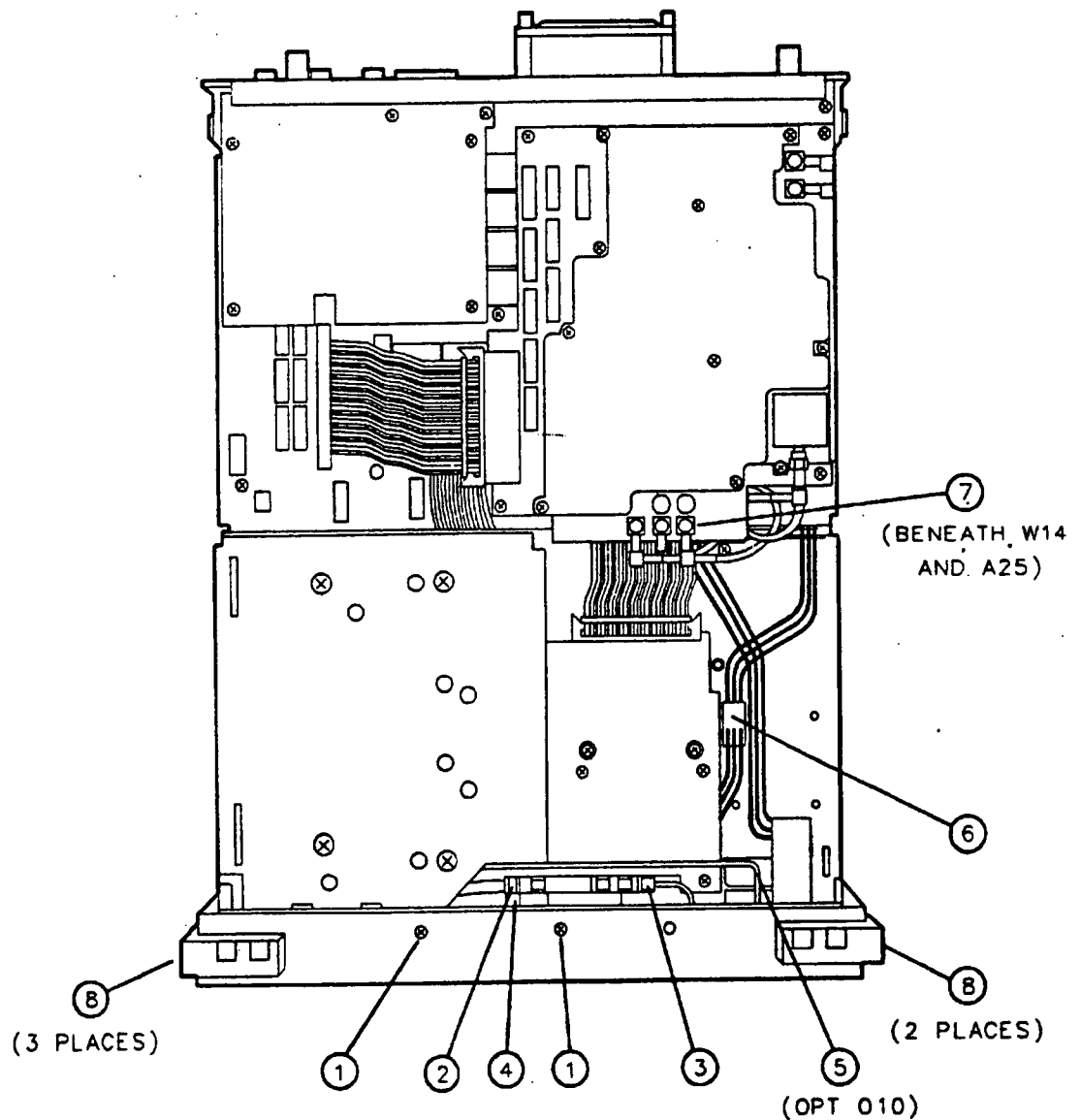

Figure 3-1. A1 Front-Frame Replacement

A1 Front-Frame Assembly

Replacement

1. Connect W7 to A9J2 and route the cable down between the A2 Display assembly and the A3 Front-End Assembly.
2. Connect the W4 ribbon cable to the A1A1 Keyboard assembly.
3. Align the W10 semirigid cable (4) with the INPUT 50 Ω connector while replacing the front frame on the main chassis. Make sure that the cables attached to the front-frame are not pinched between adjacent assemblies.
4. Replace the five screws (8) that secure the front frame to the main chassis sides. There are three screws on the right and two screws on the left.
5. Place the analyzer with the front frame forward and the bottom side facing up on the work surface.
6. Connect W1 (7) to A16J9.
7. Connect W3 (6) to the connector from A1R1, the front-frame INTEN control.

Note



If the instrument came equipped with an A102 AM/FM Speaker and TV Synch Trigger (Option 102) or A103 Quasi Peak Detector (Option 103), connect W102 to the VOL control wiring connector at A1R1.

Note



If the instrument came equipped with an A3A15 Tracking Generator (Option 010), connect the W43 semirigid cable (5) to the RF OUT 50 Ω connector on the front-frame assembly.

8. Connect the W10 semirigid cable (4) at the INPUT 50 Ω connector to 10 inch-pounds.
9. Connect the W37 semirigid cable (3) to the 100 MHz COMB OUT on the front-frame assembly.
10. Place the cable tie (2) around W10 and the A3A11 and A3A12 assemblies. Tighten the cable tie to secure the A3A11 and A3A12 assemblies to the W10 semirigid cable.
11. Replace the two screws (1) that secure the front frame to the main chassis.
12. Replace the A17 Memory Card Reader. Refer to the "A17 Memory Card Reader" replacement procedure.
13. Replace the instrument cover assembly. Refer to the "Instrument Cover" replacement procedure.

A1A1 Keyboard/Front-Panel Keys

Removal

1. Remove the front frame from the analyzer. Refer to the "A1 Front-Frame Assembly" removal procedure.
2. Place the front frame face down on the work surface.
3. Disconnect W5 from A1A1J3 and the A1A2 wiring connector from A1A1J2.
4. Remove the nine screws holding the A1A1 Keyboard assembly to the front frame and remove the assembly. Be careful to keep the front frame level. All front-panel keys are now loose and held in place only by gravity.
5. Remove the rubber keypad.

Note



The front-panel menu key actuators are part of the display bezel assembly and are not replaceable. If the menu keys are damaged, replace the bezel assembly.

Replacement

1. Check that all front-panel keys are correctly placed in the front frame assembly. Figure 3-2 illustrates the positions of all keys as viewed from the backside of the front panel. Make sure that the indented orientation mark located on the back of each key is next to the raised marks located on the front-frame casting next to each key.
2. Place the rubber keypad over the keys, ensuring that the screw holes are visible through the pad.
3. Place the A1A1 Keyboard assembly over the rubber keypad. Secure with nine panhead screws.
4. Connect the A1A2 wiring connector to A1A1J2 and W5 to A1A1J3.
5. Install the front frame to the analyzer. Refer to the "A1 Front Frame" replacement procedure.

A1A1 Keyboard/Front-Panel Keys

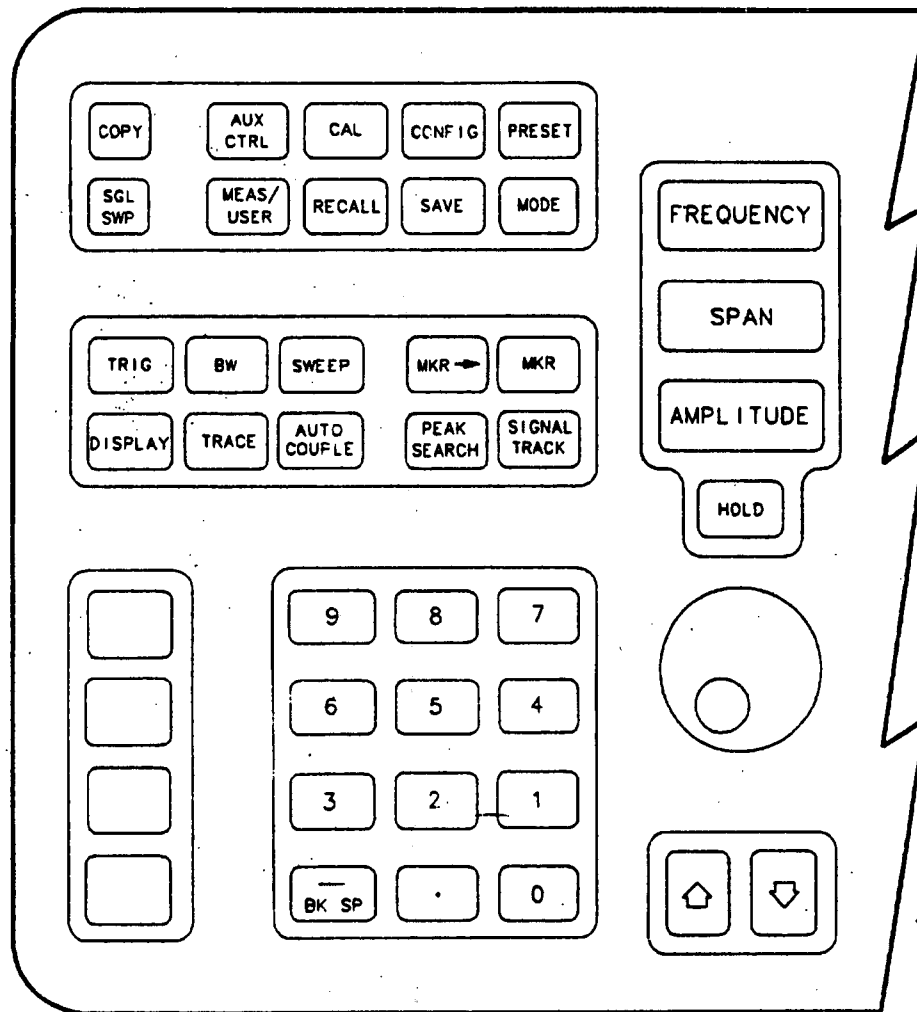

Figure 3-2. A1A1 Front-Panel Key Positions

A2 Display

Caution Use ESD precautions when performing this replacement procedure.



Removal

1. Remove the instrument cover assembly. Refer to the "Instrument Cover" removal procedure.
2. Remove the A17 Memory Card Reader. Refer to the "A17 Memory Card Reader" removal procedure.
3. Remove the A1 Front-Frame assembly. Refer to the "A1 Front-Frame Assembly" removal procedure.
4. Place the instrument on the work surface with the bottom side facing up.
5. Remove the three screws (1) that secure the A2 Display to the chassis. See Figure 3-3.
6. Disconnect the W2 wire harness (2) from A16J8 on the A16 Processor/Video Board Assembly.
7. Place the instrument on its right side.

Caution The plastic locking clip on the W3 connector (3) is fragile. Protect the connector by wrapping it with a piece of tape before pushing it down into the slot (4) on the instrument chassis.



8. Push the W2 wire harness (2) and the W3 wire harness (3) down into the slot (4) on the instrument chassis.
9. Hold the display in position and remove the two screws (5) that secure the display to the left side of the instrument chassis.

Caution A corner of the A8 Power Supply partially blocks the slot (4) in the instrument chassis. Make sure that the display's wiring harness and connectors do not jam between the power supply and the chassis.



10. Slowly remove the display assembly from the front of the instrument. Continue to route W2 and W3 through the slot (4) as the display is removed.

A2 Display

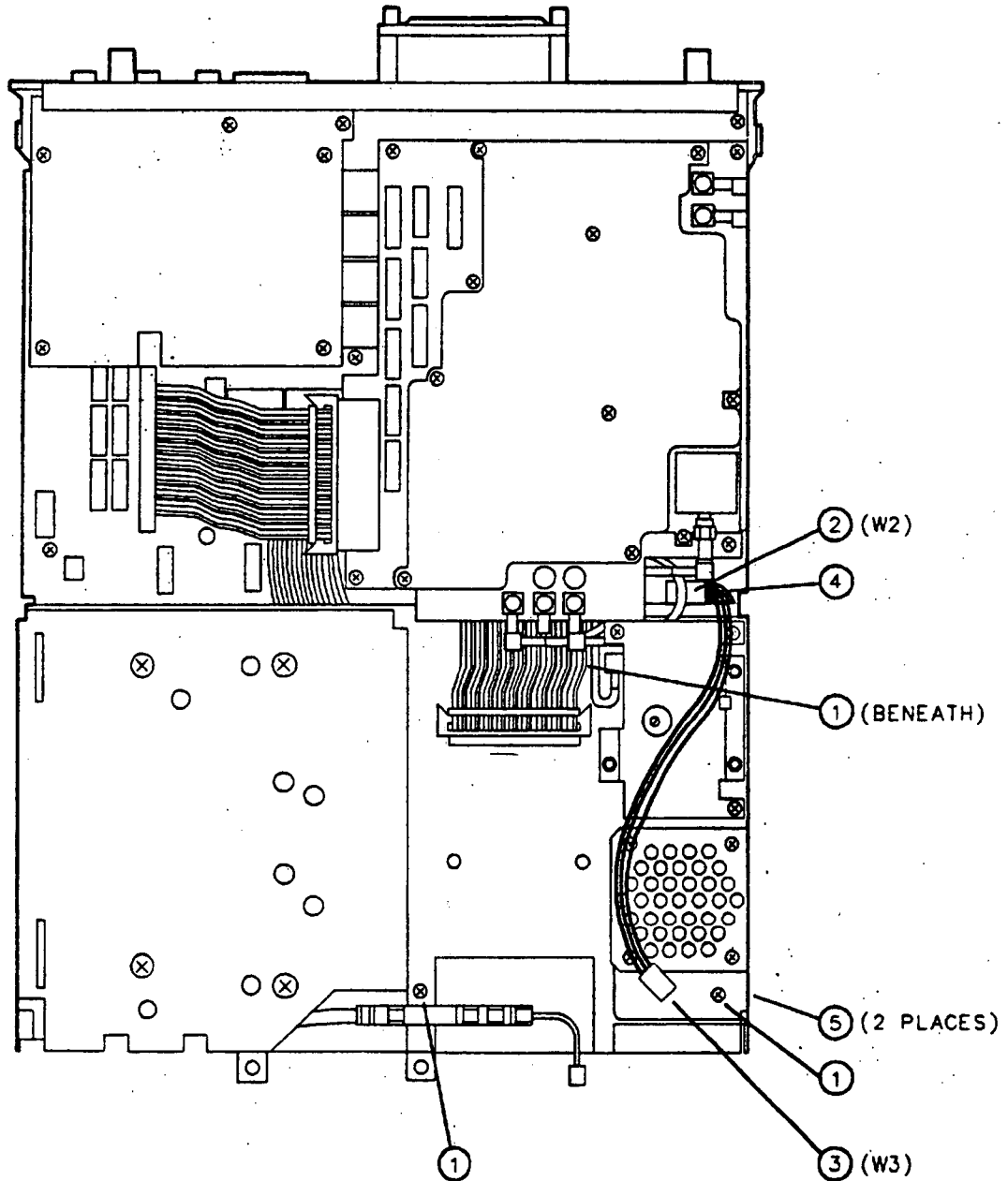

Figure 3-3. A2 Display Replacement

11. Remove the screw and flat washer (6) that secure the A2 display to its enclosure (7). See Figure 3-4.
12. Slowly pull the display out of its enclosure while routing W2 and W3 through the opening in the enclosure (8).

Warning



A high-voltage potential may remain within the A2 Display assembly for some time after it has been removed from the instrument. Do not attempt to remove the post-accelerator lead from the cathode-ray tube.

13. Disconnect W2 (9) and W3 (10) from the display.

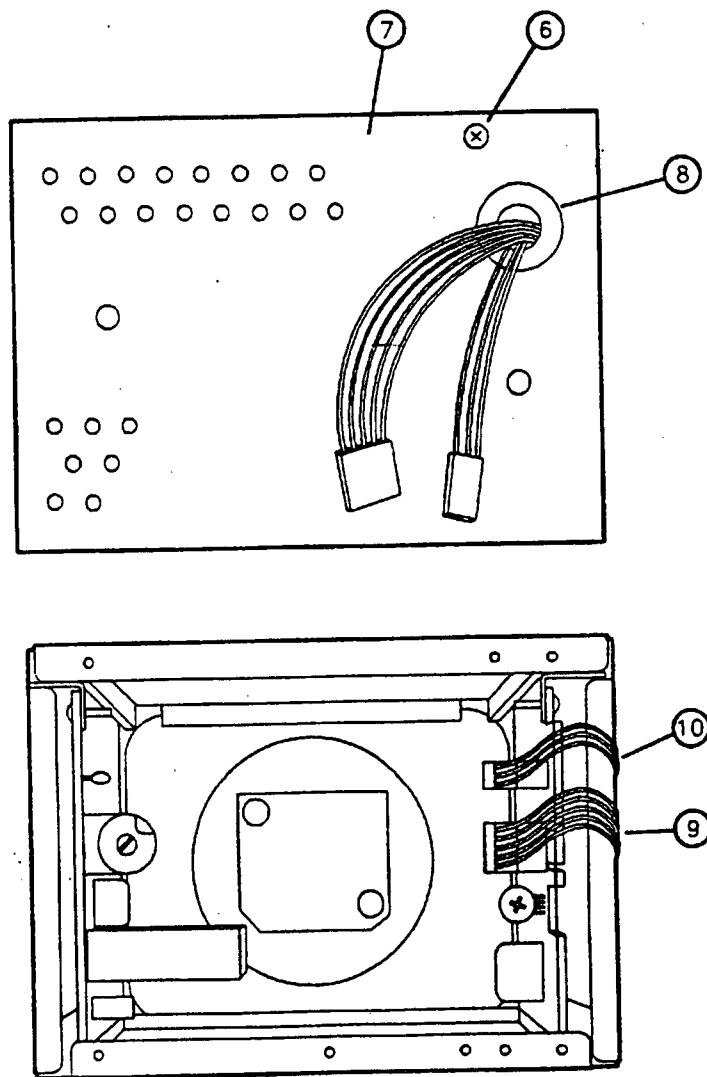

Figure 3-4. A2 Display, Rear View

A2 Display

Replacement

1. Connect W2 (9) and W3 (10) to the A2 Display. See Figure 3-4.

Caution

The plastic locking clip on the W3 connector (10) is fragile. Protect the connector by wrapping it with a piece of tape before pushing it through the opening (8) on the enclosure.

2. Place the display close to the front of the enclosure and route W2 and W3 out through the opening (8).
3. Slowly push the display into the enclosure while pulling W2 and W3 through the opening (8).
4. Replace the screw and flat washer (6) that secure the display to the enclosure.
5. Place the instrument on the work surface so that it is resting on its right side.
6. Position the display assembly part of the way into the front of the instrument.
7. Begin to push W2 and W3 out through the slot (4) in the instrument chassis. See Figure 3-3.

Caution

A corner of the A8 Power Supply partially blocks the slot (4) in the instrument chassis. Make sure that the display's wiring harness and connectors do not jam between the power supply and the chassis.

8. Replace the display in the instrument while carefully pulling W2 and W3 through the slot (4) in the instrument chassis.
9. Hold the display in position and replace the two screws (5) that secure the display to the left side of the instrument chassis.
10. Place the instrument on the work surface with the bottom side facing up.
11. Remove the tape protecting the plastic clip on W3 (3).
12. Connect W2 (2) to A16J8 on the A16 Processor/Video Board Assembly.
13. Replace the three screws (1) that secure the display to the chassis.
14. Replace the A1 Front-Frame assembly. Refer to the "A1 Front-Frame Assembly" replacement procedure.
15. Replace the A17 Memory Card Reader. Refer to the "A17 Memory Card Reader" replacement procedure.
16. Replace the instrument cover assembly. Refer to the "Instrument Cover" replacement procedure.

Before Replacing the A3 Front-End Assembly

Introduction

Replacement procedures for a complete HP 8595A A3 Front-End assembly, and the First LO Distribution Amplifier and Tracking Generator assemblies within an Options 009 and 010 are provided. The location of each assembly within the A3 Front-End assembly is provided in Chapter 5.

The A3 Front-End assembly replacement procedures are organized in the logical order of assembly removal and replacement. Figure 3-5 provides the order of removal for each assembly within the A3 Front-End assembly.

The A3 Front-End assembly replacement procedures provided are based on the order of removal shown in Figure 3-5, as follows:

- “A3A3 Low-Pass Filter and A3A9 Bandpass Filter” describes the replacement of either filter. The filters can be replaced without removing the front-end assembly.
- “A3 Front-End Assembly” provides for the replacement of a complete front-end assembly.
- After the A3 Front-End assembly has been removed, any one of the following replacement procedures can be done for the assemblies that are part of the A3 Front-End assembly.
 - “FL1 Low-Pass Filter” provides for the replacement of the FL1 Low-Pass Filter.
 - “A3A15 Tracking Generator (Option 010)” provides for the replacement of the tracking generator. The FL1 Low-Pass Filter must be removed prior to replacing this assembly.
 - “A3A1 Comb Generator” provides for the replacement of the comb generator.
 - “A3A4 Second Converter” provides for the replacement of the second converter assembly.
 - “A3A5 Attenuator/DC Block” provides for the replacement of the attenuator assembly.
 - “A3A2 Switched YTF” provides for the replacement of the switched YTF assembly. The A3A4 Second Converter and A3A5 Attenuator/DC Block assemblies must be removed prior to replacing this assembly.
 - “A3A7 YTO” provides for the replacement of the YTO assembly. The FL1 Low-Pass Filter and A3A5 Attenuator/DC Block must be removed prior to replacing this assembly.
 - “A3A6 Dual Mixer” provides for the replacement of the dual mixer.
 - “A3A13 Isolator” provides for the replacement of the isolator. The A3A6 Dual Mixer must be removed prior to replacing this assembly.
 - “A3A14 First LO Distribution Amplifier (Option 009, 010)” provides for the replacement of the first LO distribution amplifier. The A3A6 Dual Mixer must be removed prior to replacing this assembly.

Caution



The A3 Front-End assembly has static-sensitive components. Read the “Protection from Electrostatic Discharge” section of Chapter 1 before proceeding.

Before Replacing the A3 Front-End Assembly

The standard A3 Front-End assembly contains 12 assemblies that are attached to the front-end bracket assembly. The bracket assembly is made up of four separate brackets. Whenever the brackets are called out in a replacement procedure they are designated by the letters A through D, as illustrated in Figure 3-6.

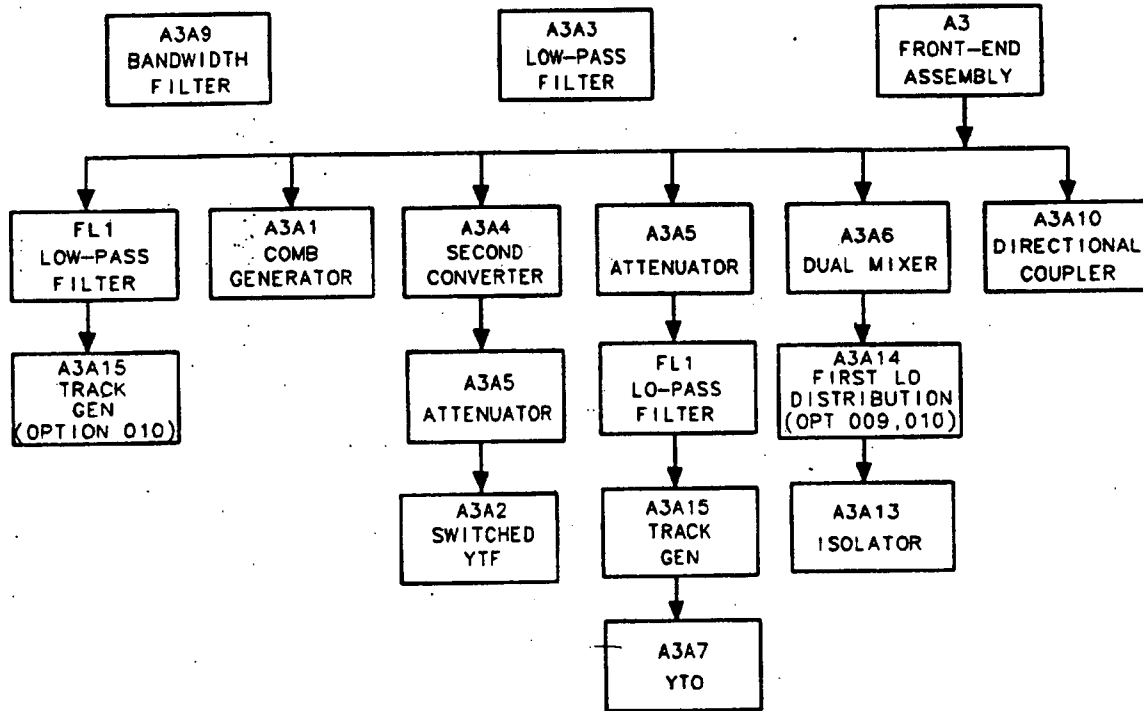

Figure 3-5. A3 Front-End Assembly Order of Removal

Before Replacing the A3 Front-End Assembly

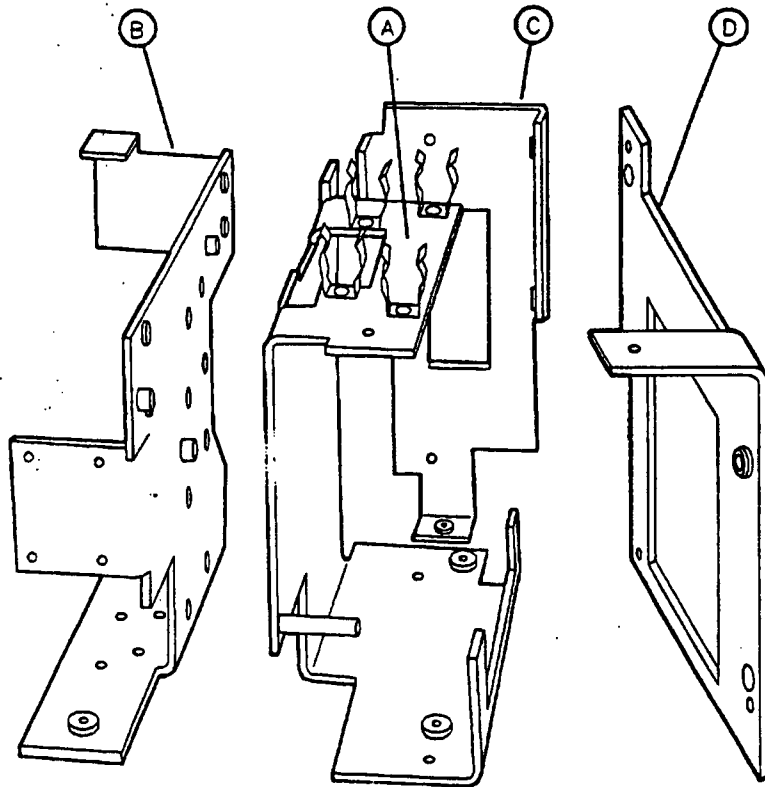

Figure 3-6. A3 Front-End Bracket Assembly

A3A3 Low-Pass and A3A9 Bandpass Filters

Caution Use ESD precautions when performing this replacement procedure.



These procedures can be used for the removal and replacement of either the A3A3 Low-Pass Filter or the A3A9 Bandpass Filter.

Removal

Note Read the “Before Replacing the A3 Front-End Assembly” section of this chapter *before* performing this procedure.



-
1. Remove the instrument cover assembly. Refer to the “Instrument Cover” removal procedure.

Caution Hold the A3A3 Low-Pass Filter firmly in place when loosening either the W26 or the W27 semirigid cable. The cables can be easily damaged if the filter is allowed to twist.



-
2. Disconnect the cables attached to the filter. Hold one end of the filter (1) in position with a 7/16 inch wrench and loosen the cable connections with a 5/16 inch wrench. See Figure 3-7.
 3. Pry the filter from the filter clips (2) attached to the “A” bracket.

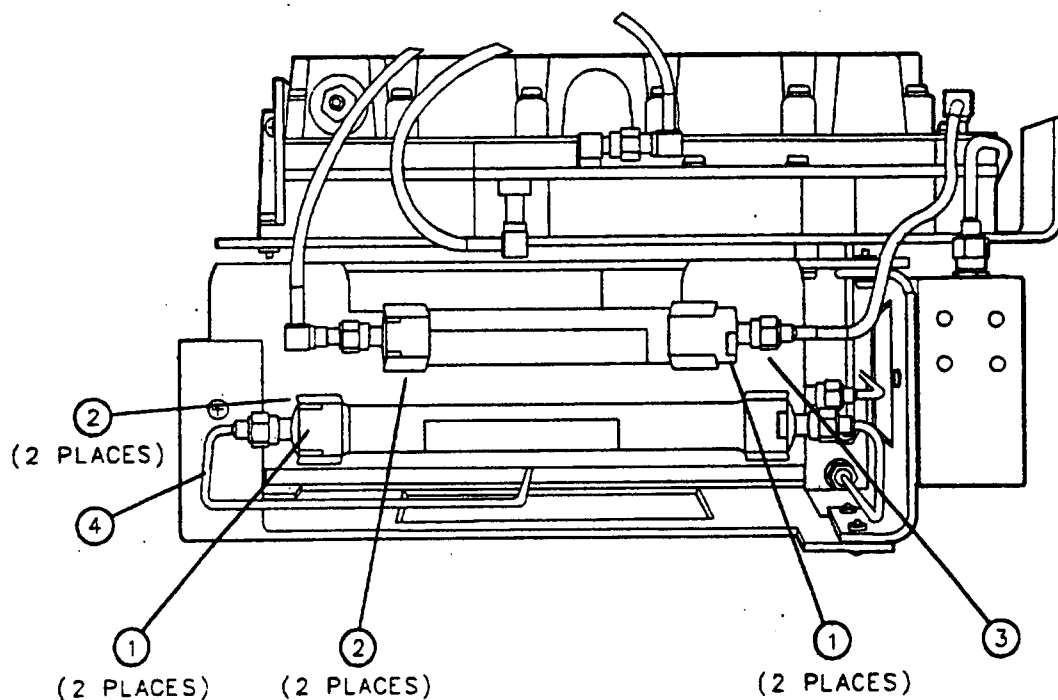

Figure 3-7. A3A3 and A3A9 Filter Replacement

Replacement

Note



Although both filters are bidirectional devices, they are installed at the factory as follows:

- The A3A9 filter connector labeled "INPUT" is connected to W23 (3). See Figure 3-7.
- The A3A3 filter is installed so that the filter label reads from left to right, with the W24 semirigid cable (4) on the left as a reference.

1. Position the filter over the filter clips (2) attached to the A3 Front-End Assembly.
2. Press the filter into place.

Caution



Hold the A3A3 Low-Pass Filter firmly in place when tightening either the W26 or the W27 semirigid cable. The cables can be easily damaged if the filter is allowed to twist.

3. Connect the cables to the filter. Hold one end of the filter (1) in position with a 7/16 inch wrench and tighten the cable connections to 10 inch-pounds using a 5/16 inch torque wrench.
4. Replace the instrument cover assembly. Refer to the "Instrument Cover" replacement procedure.

A3 Front-End Assembly

Caution Use ESD precautions when performing this replacement procedure.



Removal

Note Read the “Before Replacing the A3 Front-End Assembly” section of this chapter *before* performing this procedure.



1. Remove the instrument cover assembly. Refer to the “Instrument Cover” removal procedure.
2. Remove the front-frame assembly. Refer to the “A1 Front-Frame Assembly” removal procedure.
3. Place the instrument so that its left side is resting on the work surface.
4. Disconnect the W20 coaxial cable (1) from AT1, the 10 dB pad. See Figure 3-8.
5. Push W20 through the slot (2) on the instrument chassis.
6. Remove the four screws (3) that secure the A3 Front-End assembly to the instrument chassis.

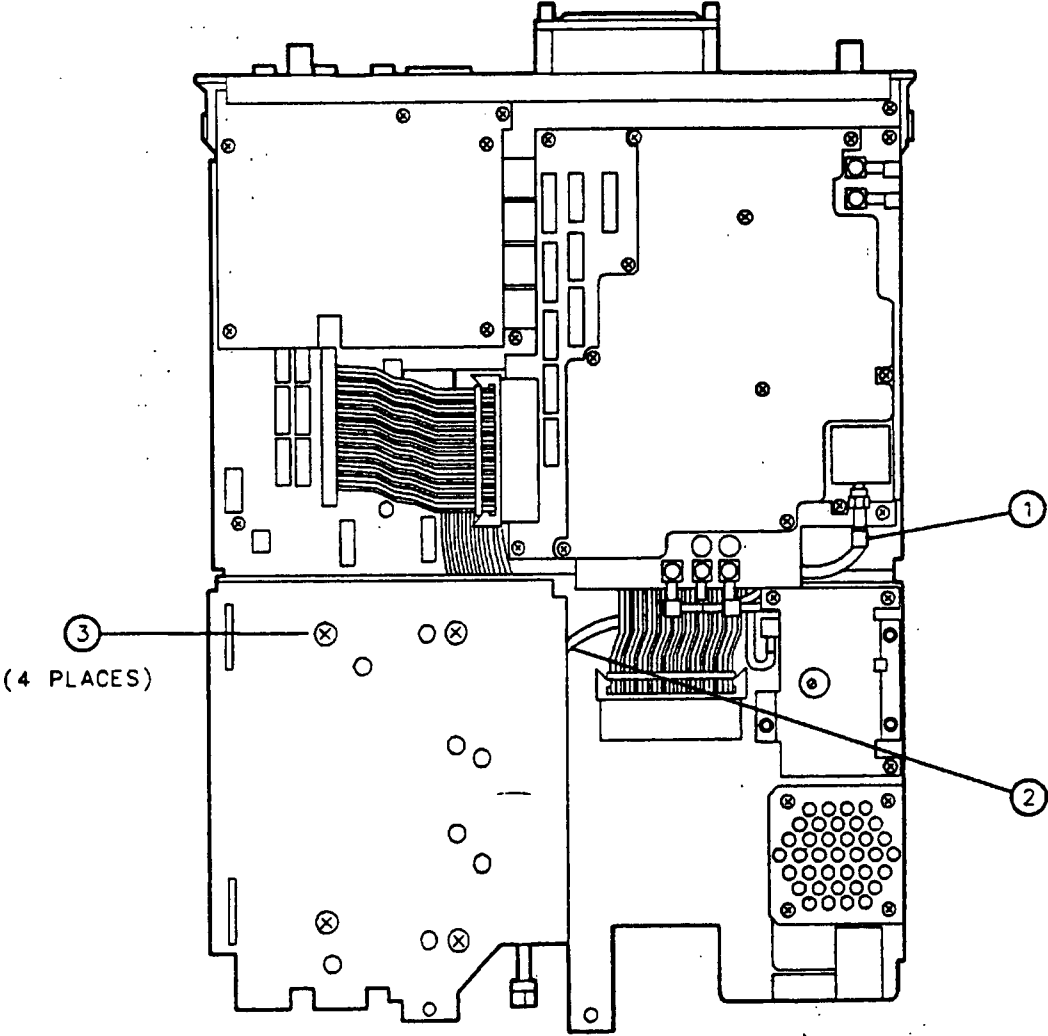

Figure 3-8. A3 Front-End Replacement, Bottom View

A3 Front-End Assembly

7. Place the instrument on the work surface with the top side facing up.
8. Remove the A7 Analog Interface assembly. Refer to the "A7 Analog Assembly" removal procedure.
9. Note how the cables attached to the A9 Third Converter assembly are dressed. (This information will be used later during the "A3 Front-End Assembly" replacement procedure.)

Note

Some card-cage options have a different cable dress that includes the use of cable tie-wraps. The tie-wraps are required to hold the wires in place during installation of the instrument cover.

10. Disconnect W8 (4) from A9J5 and W9 (4) from A9J4. See Figure 3-9.

Note

If the instrument came equipped with a tracking generator (Option 010) disconnect W39 from A10J1 and W38 from A10J2.

If the instrument came equipped with an LO Output on the rear panel (Option 009), disconnect W42 from the LO OUTPUT connector on the rear-frame assembly.

11. Remove the three screws and two washers (5) from the front-end-to-IF support bracket, then remove the bracket.
12. Tuck the cables and wire harness that are attached to the front-end assembly down into the space (6) between the "D" bracket and the A3A9 filter. This reduces the possibility that wires will be damaged while the front-end assembly is removed.
13. Lift the A3 Front-End assembly out of the instrument.

A3 Front-End Assembly

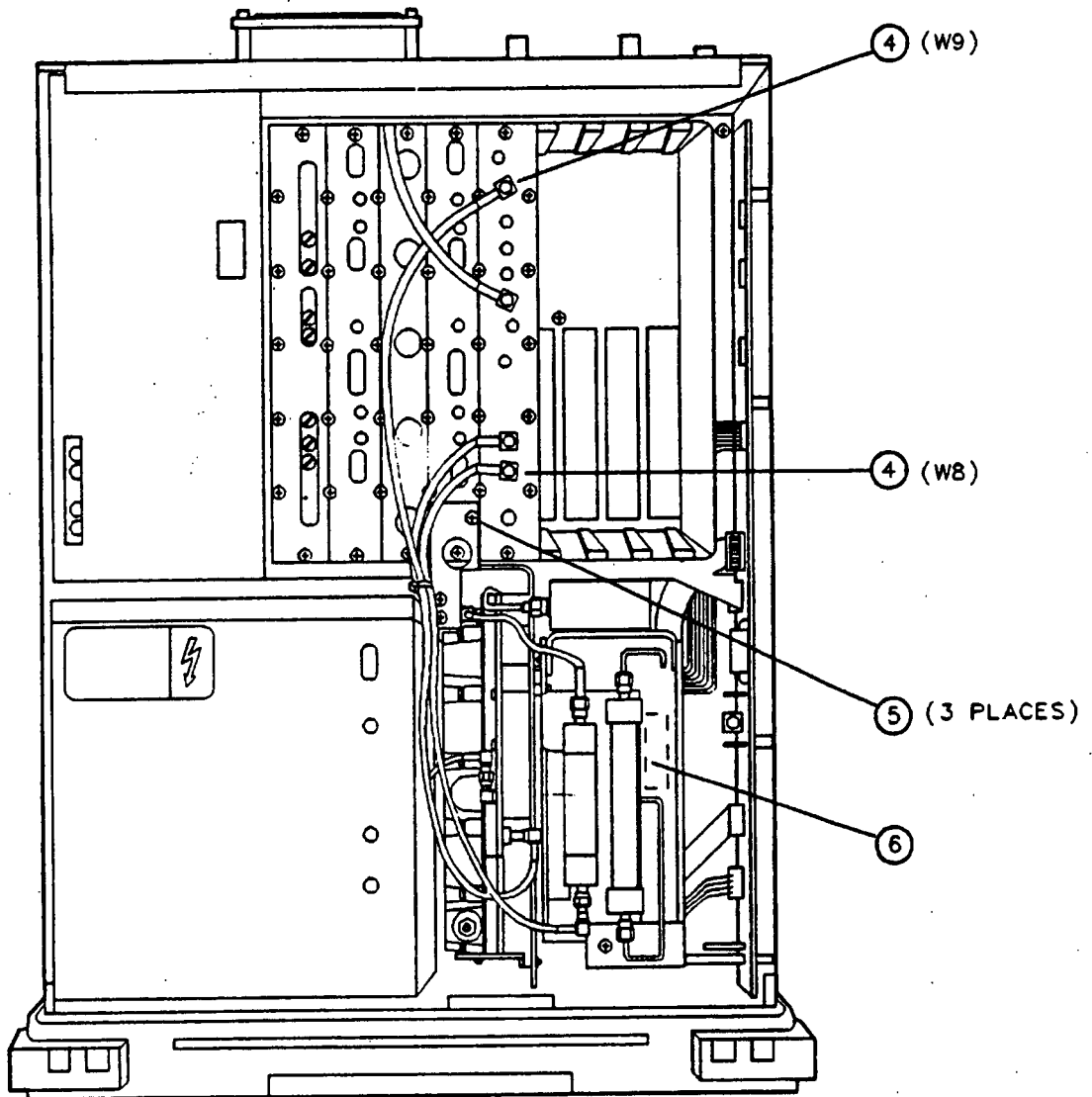

Figure 3-9. A3 Front-End Replacement, Top View

A3 Front-End Assembly

Replacement

1. Tuck all cables and wire harnesses on the A3 Front-End assembly (except for cables W20 and W24) down into the space (6) between the "D" bracket and the A3A9 filter. This reduces the possibility of damaging wires while replacing the front-end assembly. See Figure 3-9.
2. Place the instrument on the work surface with the top side facing up.
3. Set the front-end assembly on top of the A2 Display assembly and route the W20 coaxial cable into the slot on the instrument chassis that is just below the lower-right rear corner of the A2 Display assembly.
4. Position the front-end assembly over the front-end section of the instrument chassis.

Caution



Protect the center pin of the W10 semirigid cable and make sure that cables W20 and W24, as well as all other wiring, are not pinched between the front-end assembly and the instrument.

5. Lower the front-end assembly into the instrument chassis.
6. Replace the front-end-to-IF support bracket, and install the three screws and two washers (5) on the bracket without tightening.
7. Connect W8 (4) to A9J5 and W9 (4) to A9J4. See Figure 3-9.

Note



If the instrument came equipped with a tracking generator (Option 010) connect W39 to A10J1 and W38 to A10J2.

If the instrument came equipped with an LO Output on the rear panel (Option 009), connect W42 to the LO OUTPUT connector on the rear-frame assembly.

8. Place the instrument so that its left side is resting on the work surface.
9. Install and tighten the four screws (3) that secure the front-end assembly to the chassis. See Figure 3-8.
10. Route W20 through the slot (2) in the instrument chassis and under the ribbon cable.
11. Connect W20 (1) to the AT1 assembly and tighten it to 10 inch-pounds.
12. Place the instrument on the work surface with the top side facing up.
13. Tighten the three screws (5) on the front-end-to-IF support bracket. See Figure 3-9.
14. Replace the A7 Analog Board assembly. Refer to the "A7 Analog Interface Assembly" replacement procedure.
15. Dress all cables as noted during the removal procedure.

Note



For card-cage options with additional wiring, replace the original tie-wraps and dress the wiring so that there will be no interference with the instrument cover assembly.

16. Replace the front-frame assembly. Refer to the "A1 Front-Frame Assembly" replacement procedure.
17. Replace the instrument cover assembly. Refer to the "Instrument Cover" replacement procedure in Chapter 3 of the Service Manual.

FL1 Low-Pass Filter

Caution Use ESD precautions when performing this replacement procedure.



Removal

Note Read the "Before Replacing the A3 Front-End Assembly" section of this chapter *before* performing this procedure.



1. Remove the instrument cover assembly. Refer to the "Instrument Cover" removal procedure.
2. Remove the A3 Front-End Assembly. Refer to the "A3 Front-End Assembly" removal procedure.
3. Place the A3 Front-End Assembly on the work surface with the right side of the assembly facing out.

Caution The FL1 filter can be easily damaged. Make sure that the body of the filter is not allowed to bend or twist while loosening the cables attached to the filter.



4. Reach through the opening in the "D" bracket and loosen W29 (1) on the A3A6 Dual Mixer. See Figure 3-10. Do not disconnect W29.
5. Place the front-end assembly on the work surface with the left side facing up. Be sure that no wiring is pinched beneath the front-end assembly.

Note Hold the W30 semirigid cable firmly in position while loosening the cable-connector nut at the A3A4 Second Converter. This reduces stress on the FL1 filter.



6. Loosen W30 (2) at the second converter with a 5/16 inch wrench.
7. Disconnect the FL1 filter from W29 (3) using a 5/16 inch wrench on the filter connector and a 1/4 inch wrench on the W29 connector.
8. Disconnect the FL1 filter from W30 (4) using a 5/16 inch wrench on the filter connector and a 1/4 inch wrench on the W30 connector.
9. Remove the two screws and flat washers (5), then remove the FL1 filter and the filter clamps.

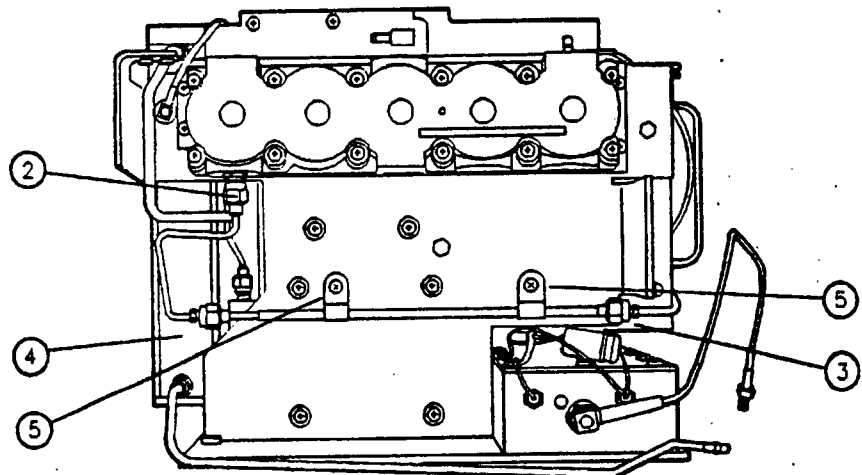
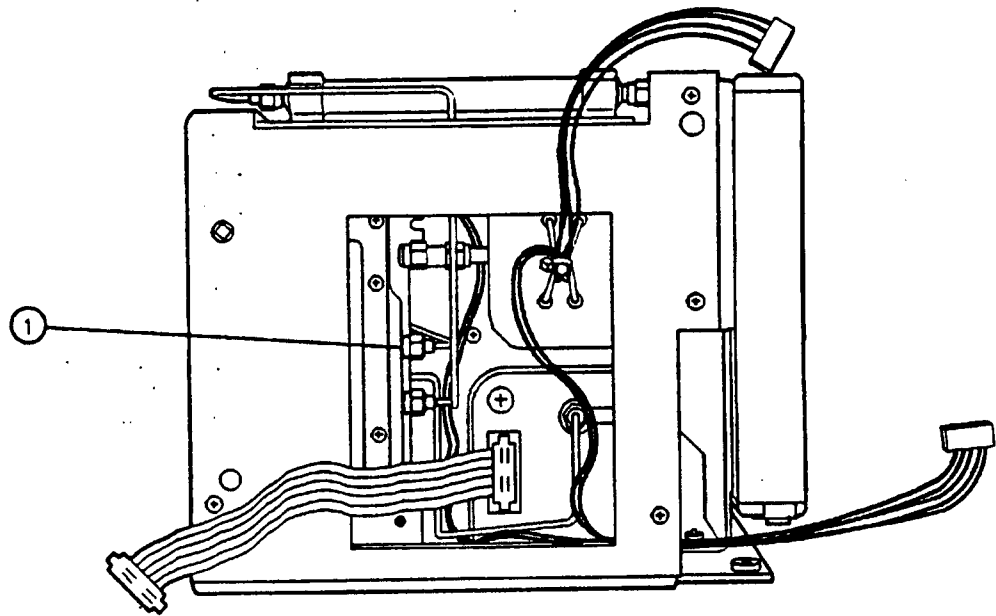

Figure 3-10. FL1 Filter Replacement

FL1 Low-Pass Filter

Replacement

1. Place the A3 Front-End Assembly on the work surface with the left side facing up. Be sure that no wiring is pinched beneath the front-end assembly.
2. Position the FL1 filter in the two filter clamps and replace the two screws and flat washers (5). See Figure 3-10. Make sure that the warning label on the filter is right-side up and facing out.
3. Connect the FL1 filter to W30 (4).

Caution



The FL1 filter can be easily damaged. Make sure that the body of the filter is not allowed to bend or twist while tightening the cable connector-nuts attached to the filter.

4. Tighten W30 to 10 inch-pounds with a 5/16 inch torque wrench. Hold the W30 connector firmly in position with a 1/4 inch wrench while tightening.
5. Connect the FL1 filter to W29 (3).
6. Tighten W29 to 10 inch-pounds. Hold the W29 connector firmly in position with a 1/4 inch wrench.
7. Tighten W30 (2) on the A3A4 Second Converter assembly to 10 inch-pounds. Hold the W30 semirigid cable firmly in position.
8. Place the front-end assembly on the work surface with the right side of the assembly facing out.
9. Tighten W29 (1) on the A3A6 Dual Mixer to 10 inch-pounds.
10. Replace the A3 Front-End Assembly. Refer to the "A3 Front-End Assembly" replacement procedure.
11. Replace the instrument cover assembly. Refer to the "Instrument Cover" replacement procedure.

A3A15 Tracking Generator (Option 010)

Caution Use ESD precautions when performing this replacement procedure.



Removal

Note Read the "Before Replacing the A3 Front-End Assembly" section of this chapter *before* performing this procedure.



1. Remove the instrument cover assembly. Refer to the "Instrument Cover" removal procedure.
2. Remove the A3 Front-End assembly. Refer to the "A3 Front-End Assembly" removal procedure.

Caution The FL1 filter can be easily damaged. Avoid any action that causes the filter to bend or twist.



3. Remove the FL1 Low-Pass Filter. Refer to the "FL1 Low-Pass Filter" removal procedure.

Caution The area between the second converter and the tracking generator is limited. Be careful when removing the W41 and W43 semirigid cables.



4. Disconnect the W41 and W43 semirigid cables (1) from the A3A15 Tracking Generator. See Figure 3-11.
5. Disconnect the W40 and W42 coaxial cables (2) from the A3A15 Tracking Generator.
6. Remove the three screws (3) that secure the A3A15 to the "B" bracket.
7. Remove the tracking generator from the front-end assembly.

A3A15 Tracking Generator (Option 010)

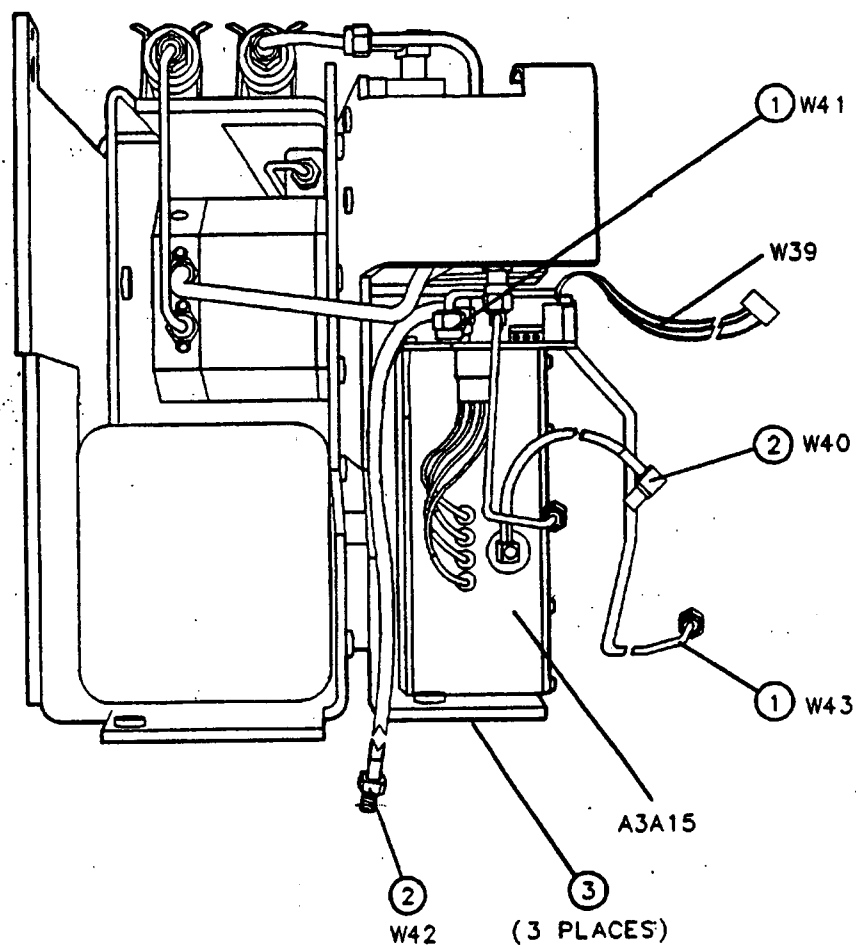

Figure 3-11. A3A15 Tracking Generator Replacement

Replacement

1. Position the A3A15 Tracking Generator in the A3 Front-End assembly.
2. Replace the three screws (3) that secure the tracking generator to the "B" bracket. See Figure 3-11.
3. Connect the W40 and W42 coaxial cables (2) to the A3A15 Tracking Generator.

Caution



The area between the second converter and the tracking generator is limited. Be careful when replacing the W41 and W43 semirigid cables.

4. Connect the W41 and W43 semirigid cables (1) to the A3A15 Tracking Generator.

Caution



The FL1 filter can be easily damaged. Avoid any action that causes the filter to bend or twist.

5. Replace the FL1 Low-Pass Filter. Refer to the "FL1 Low-Pass Filter" replacement procedure.
6. Replace the A3 Front-End assembly. Refer to the "A3 Front-End Assembly" replacement procedure.
7. Replace the instrument cover assembly. Refer to the "Instrument Cover" replacement procedure.

A3A1 Comb Generator

Caution Use ESD precautions when performing this replacement procedure.



Removal

Note Read the "Before Replacing the A3 Front-End Assembly" section of this chapter *before* performing this procedure.



1. Remove the instrument cover assembly. Refer to the "Instrument Cover" removal procedure.
2. Remove the A3 Front-End Assembly. Refer to the "A3 Front-End Assembly" removal procedure.
3. Disconnect the W24 coaxial cable (1) from the A3A1 Comb Generator. See Figure 3-12.
4. Desolder the orange wire (2) from the ground lug on the comb generator.
5. Desolder the violet wire (3) from the terminal on the comb generator.
6. Desolder the yellow wire (4) from the terminal on the comb generator.
7. Remove the two screws (5) that secure the comb generator to the "A" and "B" brackets.
8. Remove the comb generator from the front-end assembly.

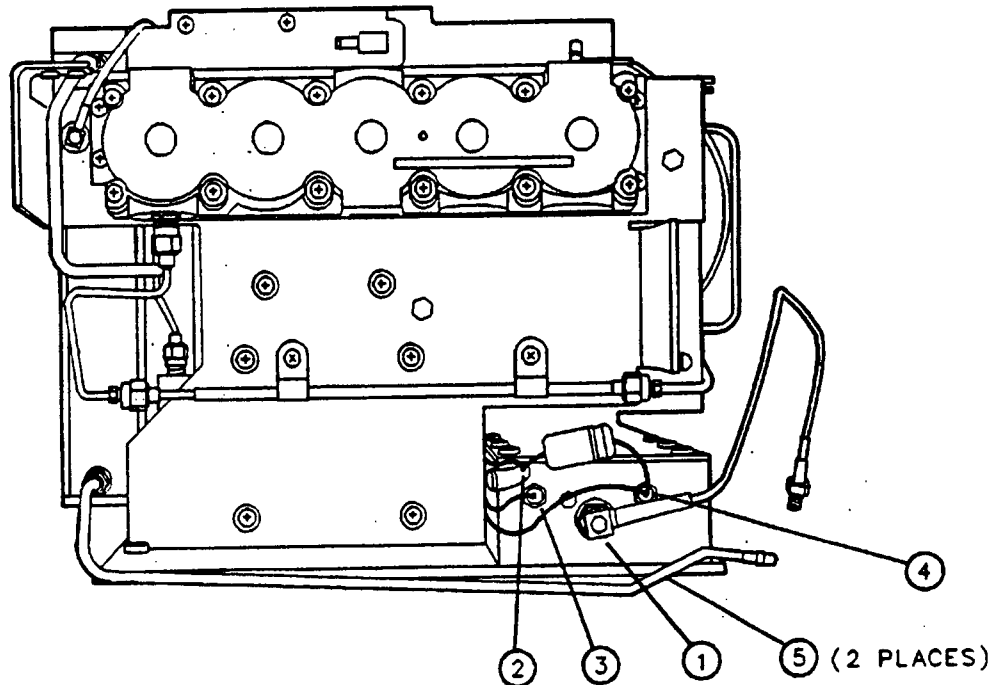

Figure 3-12. A3A1 Comb Generator Replacement

Replacement

1. Position the A3A1 Comb Generator in the A3 Front-End Assembly.
2. Replace the two screws (5) that secure the comb generator to the "A" and "B" brackets. See Figure 3-12.
3. Solder the yellow wire (4) to the terminal on the comb generator.
4. Solder the violet wire (3) to the terminal on the comb generator.
5. Solder the orange wire (2) to the ground lug on the comb generator.
6. Connect the W24 coaxial cable (1) to the A3A1 Comb Generator and position it as shown in Figure 3-12.
7. Tighten W24 to 10 inch-pounds with a 5/16 inch torque wrench.
8. Replace the A3 Front-End Assembly. Refer to the "A3 Front-End Assembly" replacement procedure.
9. Replace the instrument cover assembly. Refer to the "Instrument Cover" replacement procedure.

A3A4 Second Converter

Caution Use ESD precautions when performing this replacement procedure.



Removal

Note Read the "Before Replacing the A3 Front-End Assembly" section of this chapter *before* performing this procedure.



1. Remove the instrument cover assembly. Refer to the "Instrument Cover" removal procedure.
2. Remove the A3 Front-End Assembly. Refer to the "A3 Front-End Assembly" removal procedure.
3. Place the A3 Front-End Assembly on the work surface with its left side facing up. Be sure that no wiring is pinched beneath the front-end assembly.
4. Remove W8, W22, W23, and W35 (1) from the A3A4 Second Converter. See Figure 3-13.

Caution FL1, the low-pass filter (2), can be easily damaged. Avoid any action that causes the filter to bend or twist.



5. Disconnect the W30 semirigid cable (3) from the second converter with a 5/16 inch wrench. Hold W30 firmly in position while loosening its connector nut. This reduces stress on the FL1 filter.
6. Hold the second converter in place and remove the four screws (4) that secure the second converter to the "B" bracket.
7. Remove the second-converter assembly.

A3A4 Second Converter

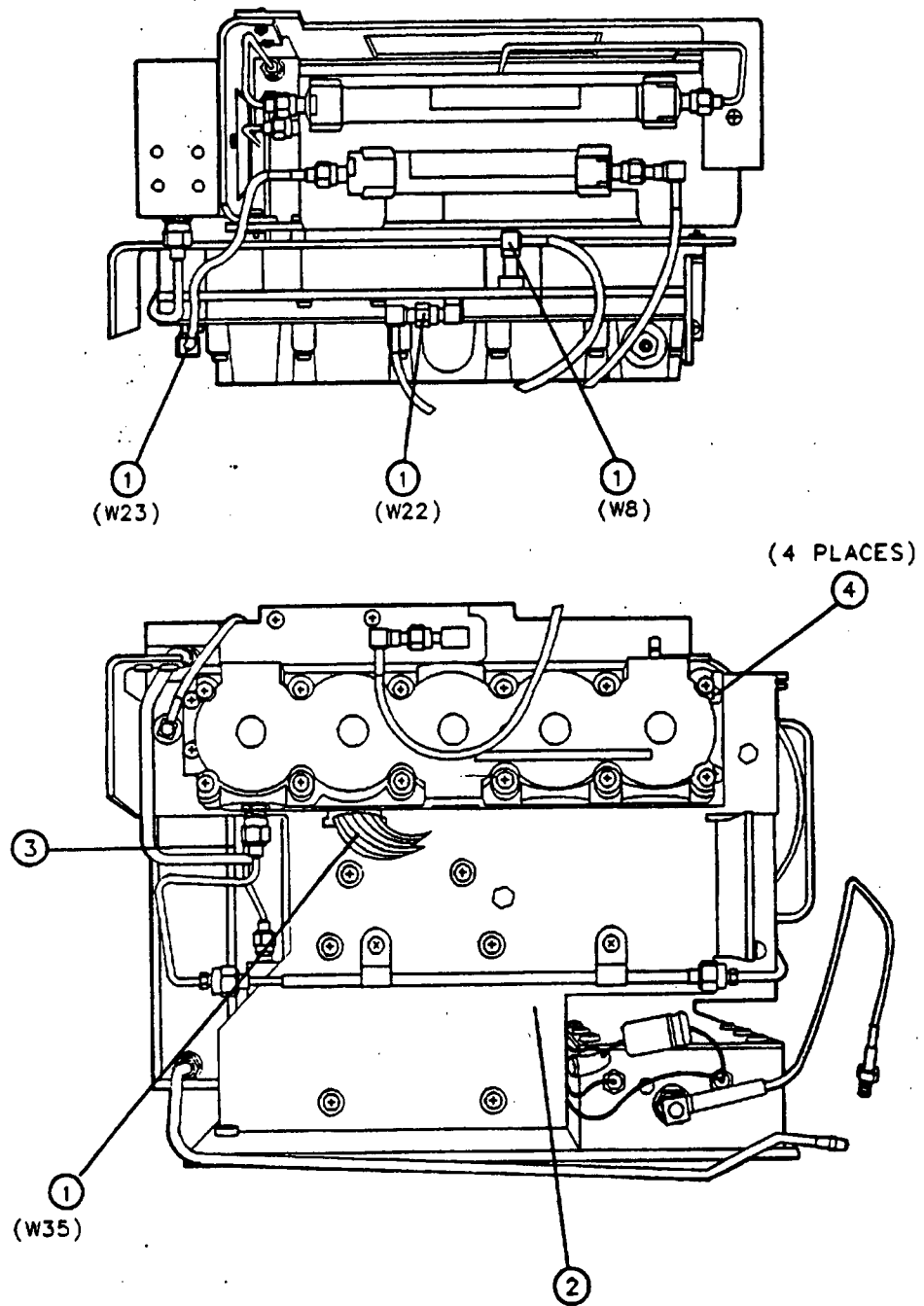

Figure 3-13. A3A4 Second Converter Replacement

A3A4 Second Converter

Replacement

1. Place the A3 Front-End Assembly on the work surface with its left side facing up. Be sure that no wiring is pinched beneath the front-end assembly.
2. Position the A3A4 Second Converter on the "B" bracket.
3. Replace the four screws (4) that secure the second converter to the "B" bracket. See Figure 3-13.

Caution

The FL1 filter (2), can be easily damaged. Avoid any action that causes the filter to bend or twist.

4. Carefully connect the W30 semirigid cable (3) to the second converter without tightening.
5. Hold W30 firmly in position and tighten its connector nut to 10 inch-pounds.
6. Replace W8, W22, W23 and W35 (1) on the A3A4 Second Converter assembly.
7. Torque the connector on W22 to 10 inch-pounds.
8. Replace the A3 Front-End Assembly. Refer to the "A3 Front-End Assembly" replacement procedure.
9. Replace the instrument cover assembly. Refer to the "Instrument Cover" replacement procedure.

A3A5 Attenuator/DC Block

Caution Use ESD precautions when performing this replacement procedure.



Removal

Note Read the "Before Replacing the A3 Front-End Assembly" section of this chapter *before* performing this procedure.



1. Remove the instrument cover assembly. Refer to the "Instrument Cover" removal procedure.
2. Remove the A3 Front-End Assembly. Refer to the "A3 Front-End Assembly" removal procedure.
3. Place the A3 Front-End Assembly on the work surface top side up.
4. Remove the two screws (1) that secure the "C" bracket to the "D" bracket. See Figure 3-6 for an illustration of the front-end bracket assembly.
5. Note the alignment of the W10 semirigid cable (2) to the left side of the front-end assembly. See Figure 3-14. (This information is used later, in the attenuator replacement procedure.)
6. Disconnect W10 (3) from the A3A5 Attenuator.
7. Disconnect the W11 semirigid cable (4) from the attenuator.
8. Hold the attenuator in place and remove the two screws (5) that secure the "C" bracket to the "A" bracket. The top screw is accessible through the hole in the "D" bracket.
9. Remove the "C" bracket and attenuator.
10. Remove the W36 ribbon cable (6) from the attenuator.
11. Remove the two screws that secure the "C" bracket to the attenuator.

A3A5 Attenuator/DC Block

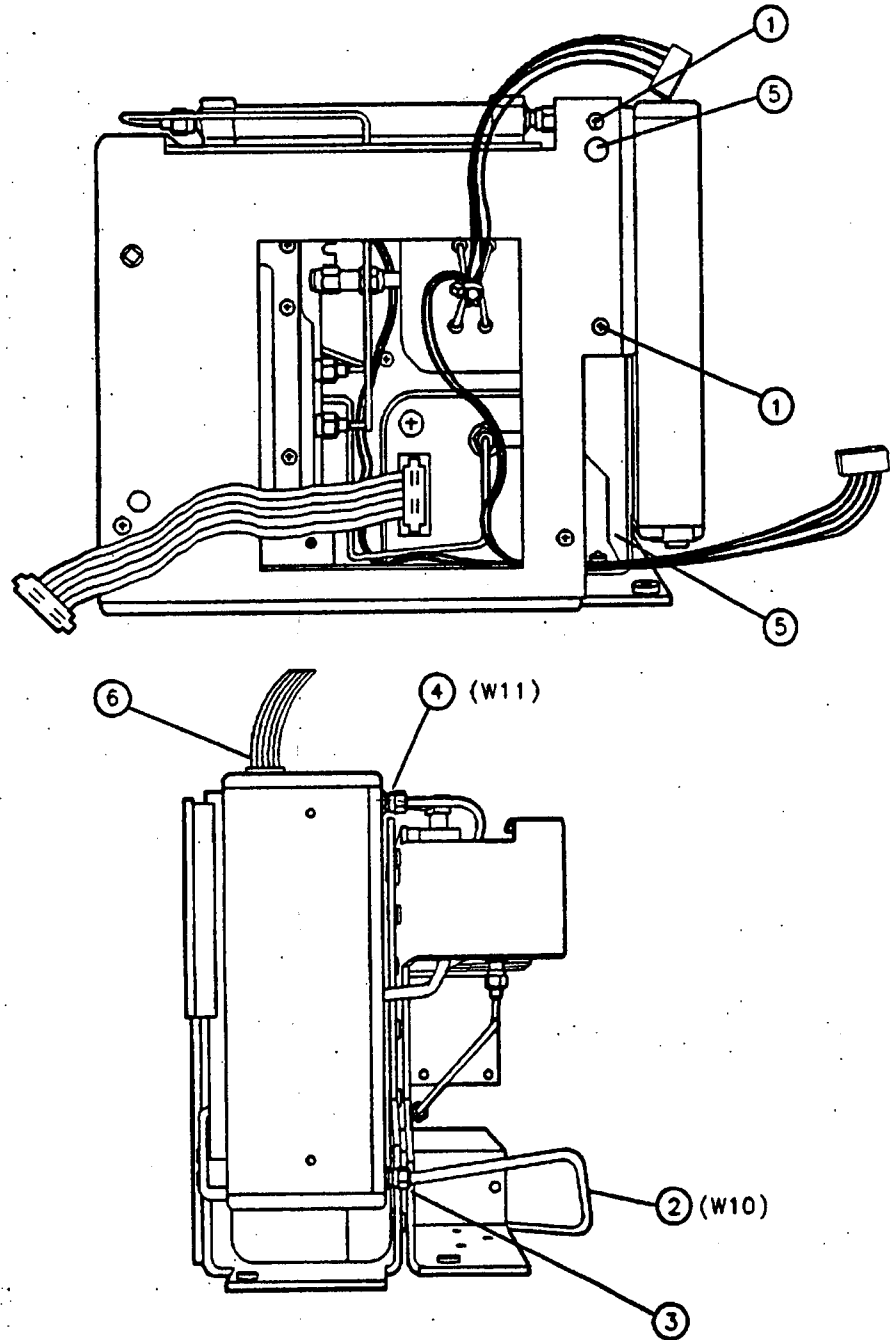

Figure 3-14. A3A5 Attenuator Replacement

Replacement

1. Position the "C" bracket on the A3A5 Attenuator and replace the two screws that secure the bracket to the attenuator.
2. Replace the W36 ribbon cable (6) on the attenuator. See Figure 3-14.
3. Position the attenuator assembly on the A3 Front-End Assembly.
4. Replace the two screws (5) that secure the "C" bracket to the "A" bracket.
5. Connect the W11 semirigid cable (4) to the attenuator and tighten to 10 inch-pounds using a 5/16 inch torque wrench.
6. Connect the W10 semirigid cable (3) to the attenuator and position as noted in the attenuator removal procedure (2).
7. Tighten W10 to 10 inch-pounds.
8. Replace the two screws (1) that secure the "C" bracket to the "D" bracket.
9. Replace the A3 Front-End Assembly in the instrument. Refer to the "A3 Front-End Assembly" replacement procedure.
10. Replace the instrument cover assembly. Refer to the "Instrument Cover" replacement procedure.

A3A2 Switched YTF

Caution Use ESD precautions when performing this replacement procedure.



Removal

Note Read the “Before Replacing the A3 Front-End Assembly” section of this chapter *before* performing this procedure.



1. Remove the instrument cover assembly. Refer to the “Instrument Cover” removal procedure.
2. Remove the A3 Front-End Assembly. Refer to the “A3 Front-End Assembly” removal procedure.
3. Remove the A3A4 Second Converter. Refer to the “A3A4 Second Converter” removal procedure.

Note Removing the second converter allows access to two of the four screws that secure the A3A2 Switched YTF to the “A” bracket.



4. Note the cable dress of W12, W13, and W34 (1) that pass through the opening in the “D” bracket. See Figure 3-15. (This information is used later, during the YTF replacement procedure.)
5. Remove the A3A5 Attenuator. Refer to the “A3A5 Attenuator” removal procedure.

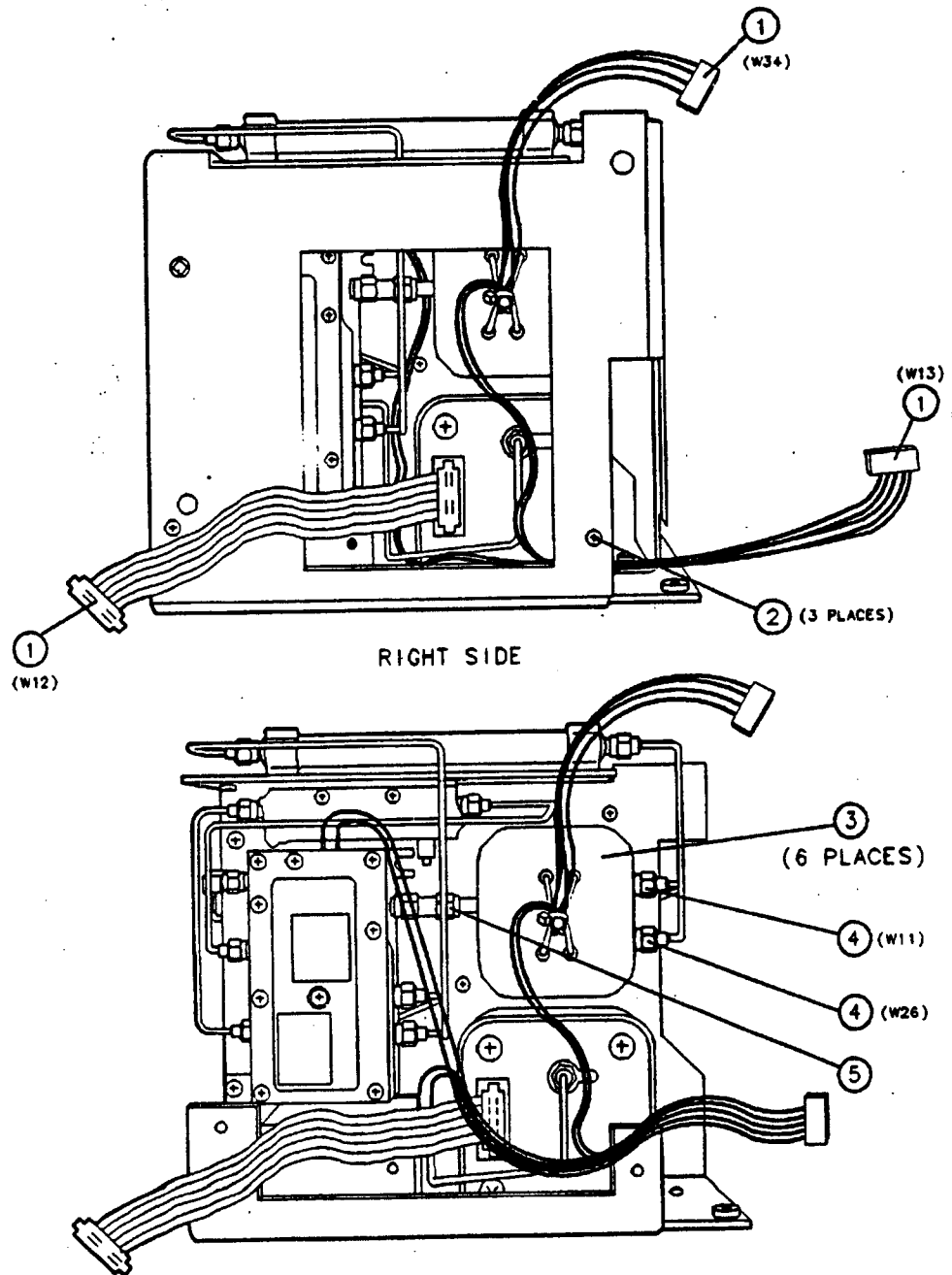

Figure 3-15. A3A2 Switched YTF Replacement

6. Place the front-end assembly on the work surface with the right side of the assembly facing up.
7. Remove the three screws (2) that hold the "D" bracket to the "A" bracket and remove the bracket.

A3A2 Switched YTF

8. Remove W13 and W34 wire harnesses (3) from the YTF using needle-nose pliers. Pull each wire straight out from the YTF assembly being careful not to bend the wire connectors.
9. Disconnect the W11 cable from A3A2J1 (4) and the W26 cable from A3A2J3 (4).
10. Place the front-end assembly on the work surface with the left side facing up. The four holes in the "B" bracket allow access to the screws installed on the back of the YTF.
11. Hold the YTF in position on the "A" bracket and remove the four screws that secure the YTF to the "A" bracket.
12. Place the front-end assembly on the work surface with the right side of the assembly facing up.
13. Disconnect the SMA adapter (5) at A3A2J2.
14. Remove the Switched YTF.

Replacement

1. Place the front-end assembly on the work surface with the right side of the assembly facing up.
2. Position the YTF and connect the A3A2J2 connector to the SMA adapter (5) without tightening. See Figure 3-15.
3. Hold the YTF in position on the "A" bracket and turn the front-end assembly over so that its left side is facing up.
4. Replace the four screws that secure the back of the YTF to the "A" bracket.
5. Place the front-end assembly on the work surface with the right side of the assembly facing up.
6. Tighten the SMA connector at A3A2J2 (5) to 10 inch-pounds using a 5/16 inch torque wrench.
7. Reconnect the W11 cable to A3A2J1 (4) and the W26 cable to A3A2J3 (4).
8. Replace the W13 and W34 wire harnesses (3) on the YTF using needle-nose pliers. Push each wire connector onto its recessed connector pin without bending. See Figure 3-15.

Caution



There are two brown wires connected to the A3A2 Switched YTF. Be sure to connect the correct brown wire to the correct terminal as described in the following note.

Note



Use the wiring illustration from Figure 3-16 that applies to the coverplate on the replacement YTF and replace the wires as follows:

- Connect the violet wire (1) to the "+ HEATER" terminal.
 - Connect the green wire (2) to the "- HEATER" terminal.
 - Connect the orange wire (3) to the "- Tune" terminal.
 - Connect the brown wire of the W34 wire harness (4) to the "+ Tune" terminal.
 - Connect the red (5) to the "LOW SWITCH" terminal.
 - Connect the brown wire of the W13 wire harness (6) to the "HI SWITCH" terminal.
-

A3A2 Switched YTF

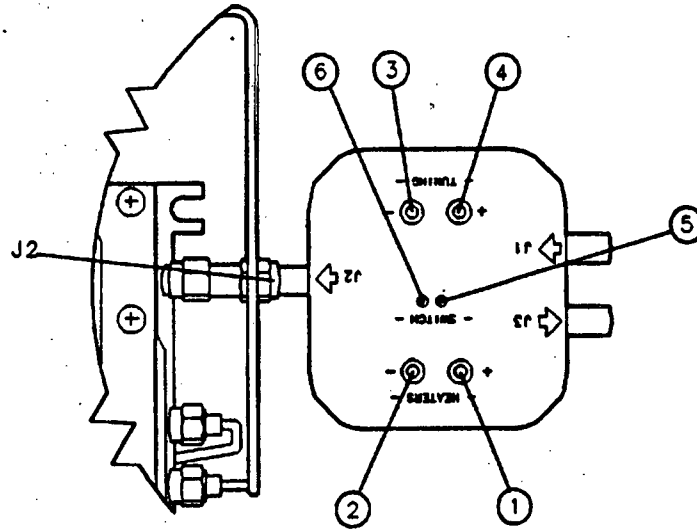

Figure 3-16. A3A2 Switched YTF Wiring Replacement

9. Pass W12, W13, and W34 (1) through the opening in the "D" bracket. See Figure 3-15.
10. Position the "D" bracket on the front-end assembly and replace the three screws (2) that hold it to the "A" bracket.
11. Replace the A3A5 Attenuator. Refer to the "A3A5 Attenuator" replacement procedure.
12. Reposition W12, W34, and W13 (1) as noted during the YTF removal procedure.
13. Replace the A3A4 Second Converter. Refer to the "A3A4 Second Converter" replacement procedure.
14. Replace the A3 Front-End Assembly. Refer to the "A3 Front-End Assembly" replacement procedure.
15. Replace the instrument cover assembly. Refer to the "Instrument Cover" replacement procedure.

A3A7 YTO

Caution

Use ESD precautions when performing this replacement procedure.



Removal

Note

Read the "Before Replacing the A3 Front-End Assembly" section of this chapter *before* performing this procedure.



1. Remove the instrument cover assembly. Refer to the "Instrument Cover" removal procedure.
2. Remove the A3 Front-End Assembly. Refer to the "A3 Front-End Assembly" removal procedure.
3. Note the cable dress of W12, W34, and W13 (1) that pass through the opening in the "D" bracket. See Figure 3-17. (This information is used later, during the YTO replacement procedure.)
4. Remove the A3A5 Attenuator. Refer to the "A3A5 Attenuator" removal procedure.
5. Place the front-end assembly on the work surface with the right side of the assembly facing up.
6. Remove the three screws (2) that secure the "D" bracket to the "A" bracket, and remove the "D" bracket.
7. Remove the W12 ribbon cable (3) from the YTO.
8. Disconnect the W31 semirigid cable (4) from the YTO.
9. Place the front-end assembly on the work surface with the left side facing up. The four holes in the "B" bracket allow access to the screws that secure the A3A7 YTO to the "A" bracket.
10. Hold the YTO assembly in position on the "A" bracket and remove the four screws that secure the YTO assembly to the "A" bracket (5).
11. Place the front-end assembly on the work surface with the right side of the assembly facing up.
12. Slide the YTO assembly to the right and out of the front-end assembly.

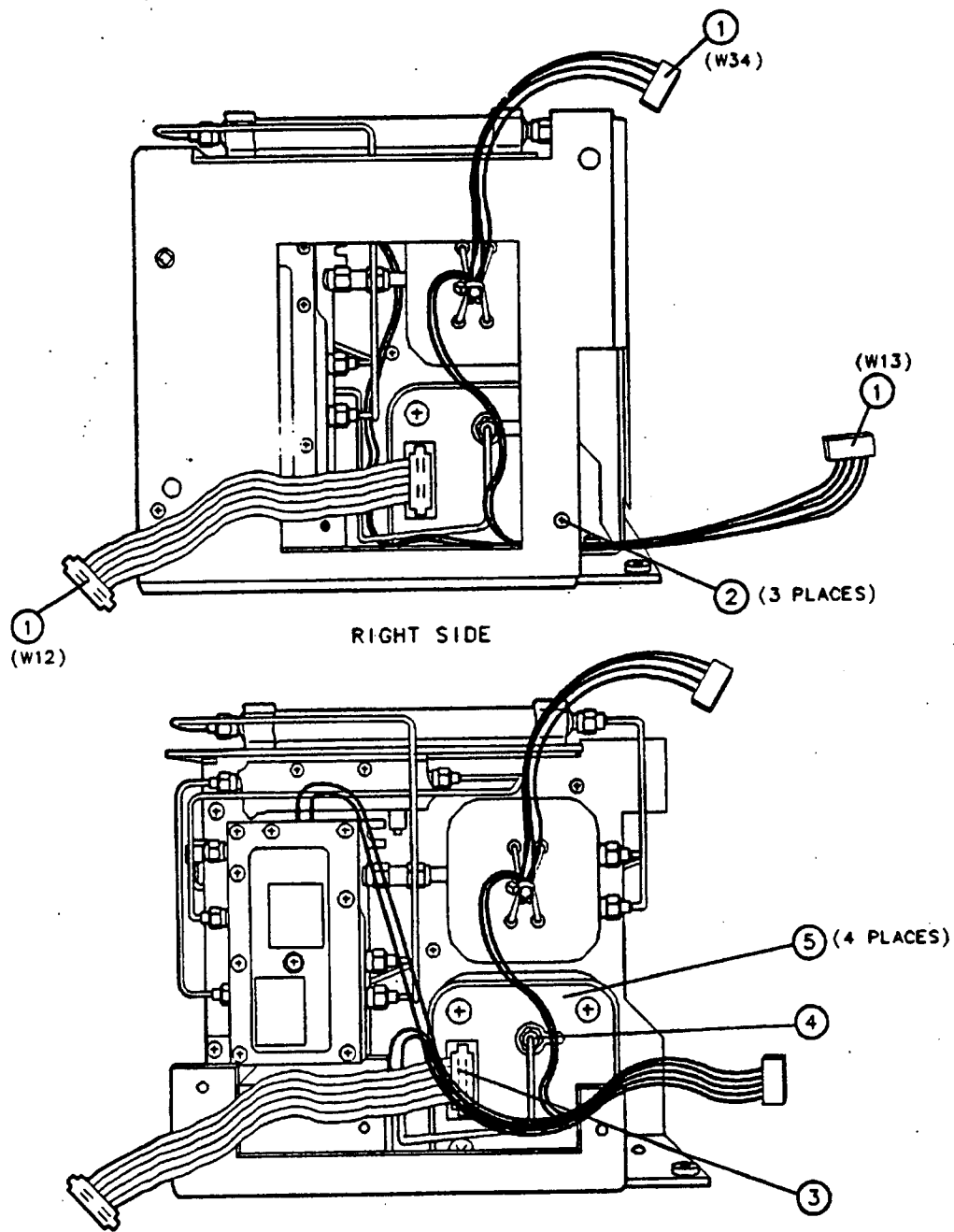

Figure 3-17. A3A7 YTO Replacement

A3A7 YTO

13. Remove the outer YTO enclosure (6). See Figure 3-18. Set the enclosure aside for use in the replacement procedure.
14. Retain the inner YTO enclosure (7) with the YTO that is being removed.
15. Remove the four screws (8) that secure the YTO cover to the YTO, and remove the cover (9). Set the cover aside for use in the replacement procedure.

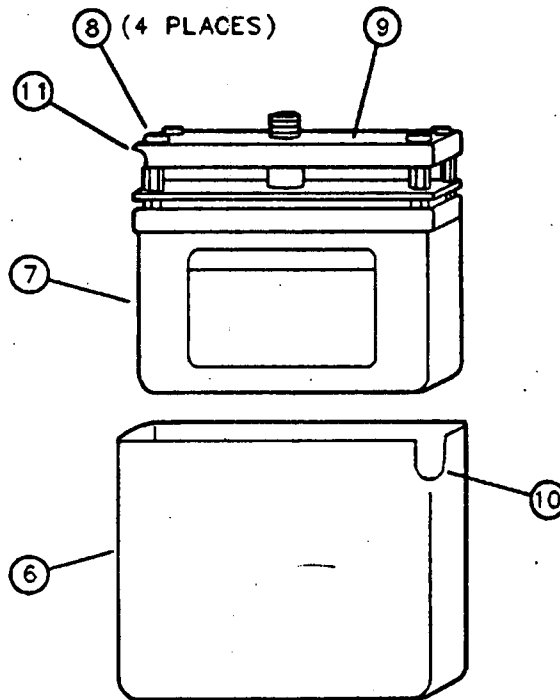

Figure 3-18. A3A7 YTO and YTO Enclosure

Replacement

1. Position the YTO cover (9) on the YTO and replace the four screws (8) that secure the YTO cover to the YTO. See Figure 3-18.
2. Make sure that the inner YTO enclosure (7) stays in position and replace the outer YTO enclosure (6) on the YTO assembly.

Note



Make sure that the notch on the outer YTO enclosure (10) and on the YTO cover (11) are not lined up when the YTO enclosure is replaced. A hole in the YTO enclosure is created if the notches are allowed to line up. An opening would reduce the magnetic-shielding ability of the enclosure.

3. Place the A3 Front-End Assembly on the work surface with the right side of the assembly facing up.
4. Place the YTO in the front-end assembly.
5. Hold the YTO in position on the "A" bracket and turn the front-end assembly over so that its left side is facing up.
6. Replace the four screws that secure the YTO assembly to the "A" bracket (5).
7. Place the front-end assembly on the work surface with the right side of the assembly facing up.
8. Connect the W31 semirigid cable (4) to the YTO and tighten to 10 inch-pounds using a 5/16 inch torque wrench. See Figure 3-17.
9. Replace the W12 ribbon cable (3) on the YTO.
10. Pass W12, W34, and W13 (1) through the opening in the "D" bracket. See Figure 3-17.
11. Position the "D" bracket on the front-end assembly and replace the three screws (2) that hold it to the "A" bracket.
12. Replace A3A5 Attenuator. Refer to the "A3A5 Attenuator" replacement procedure.
13. Reposition W12, W34, and W13 (1) as noted during the YTO removal procedure.
14. Replace the A3 Front-End Assembly. Refer to the "A3 Front-End Assembly" replacement procedure.
15. Replace the instrument cover assembly. Refer to the "Instrument Cover" replacement procedure.

A3A6 Dual Mixer

Caution Use ESD precautions when performing this replacement procedure.



Removal

Note Read the “Before Replacing the A3 Front-End Assembly” section of this chapter *before* performing this procedure.



1. Remove the instrument cover assembly. Refer to the “Instrument Cover” removal procedure.
2. Remove the A3 Front-End Assembly. Refer to the “A3 Front-End Assembly” removal procedure.
3. Place the A3 Front-End Assembly on the work surface with the right side of the assembly facing up.
4. Note the cable dress of W12, W13, and W34 wire harnesses (1) that pass through the opening in the “D” bracket. See Figure 3-19. (This information is used later, during the A3A6 Dual Mixer replacement procedure.)
5. Remove the five screws (2) that hold the “D” bracket in place and remove the bracket.

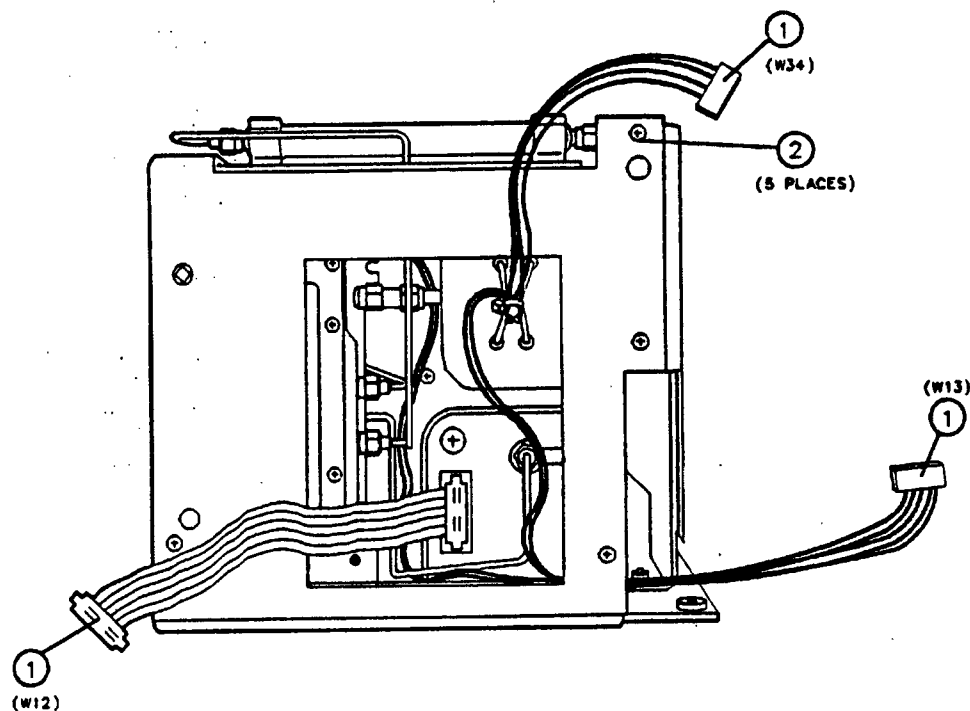

Figure 3-19. A3A6 Dual Mixer Replacement, Right-Side View

6. Loosen, but do not disconnect, the W29 semirigid cable (3) from A3A6J2 on the dual mixer. See Figure 3-20.
7. Place the front-end assembly on the work surface with the left side facing up.

Caution



The FL1 filter can be easily damaged. Avoid any action that causes the filter to bend or twist.

8. Disconnect W29 from the FL1 filter (4) using a 1/4 inch wrench on the W29 connector and a 5/16 inch wrench on the FL1 connector. If there is not enough clearance around the connector, remove the two screws and washers (5) on the cable clamps.

Note



Hold the W29 connector firmly in position while loosening the connector nut on the filter. This reduces stress on the FL1 filter.

9. Place the front-end assembly on the work surface with the right side facing up.
10. Dress all wiring away from the dual mixer.
11. Disconnect the blue wire (6) and the green wire (7) from the dual mixer, using needle-nose pliers. (The wires are part of the W13 wire harness.)
12. Disconnect the W33 semirigid cable (8) from A3A6J4 on the dual mixer.

A3A6 Dual Mixer

13. Disconnect the W22 coaxial cable (9) from A3A6J5 on the dual mixer.
14. Disconnect the W27 semirigid cable (10) from the A3A3 Low-Pass Filter.
15. Remove the screw and washer (11) that secure the dual mixer to the standoff on the "A" bracket.
16. Hold the dual mixer in position and disconnect the SMA adapter at A3A2J2 (12) on the YTF assembly using a 5/16 inch wrench.

Caution

Make sure that the W29 semirigid cable does not catch on the FL1 filter or the front-end bracket assembly during removal of the dual mixer.

17. Carefully remove the dual mixer from the front-end assembly.
18. Remove the SMA adapter from A3A6J3, the W29 semirigid cable from A3A6J2, and the W27 semirigid cable from A3A6J1.

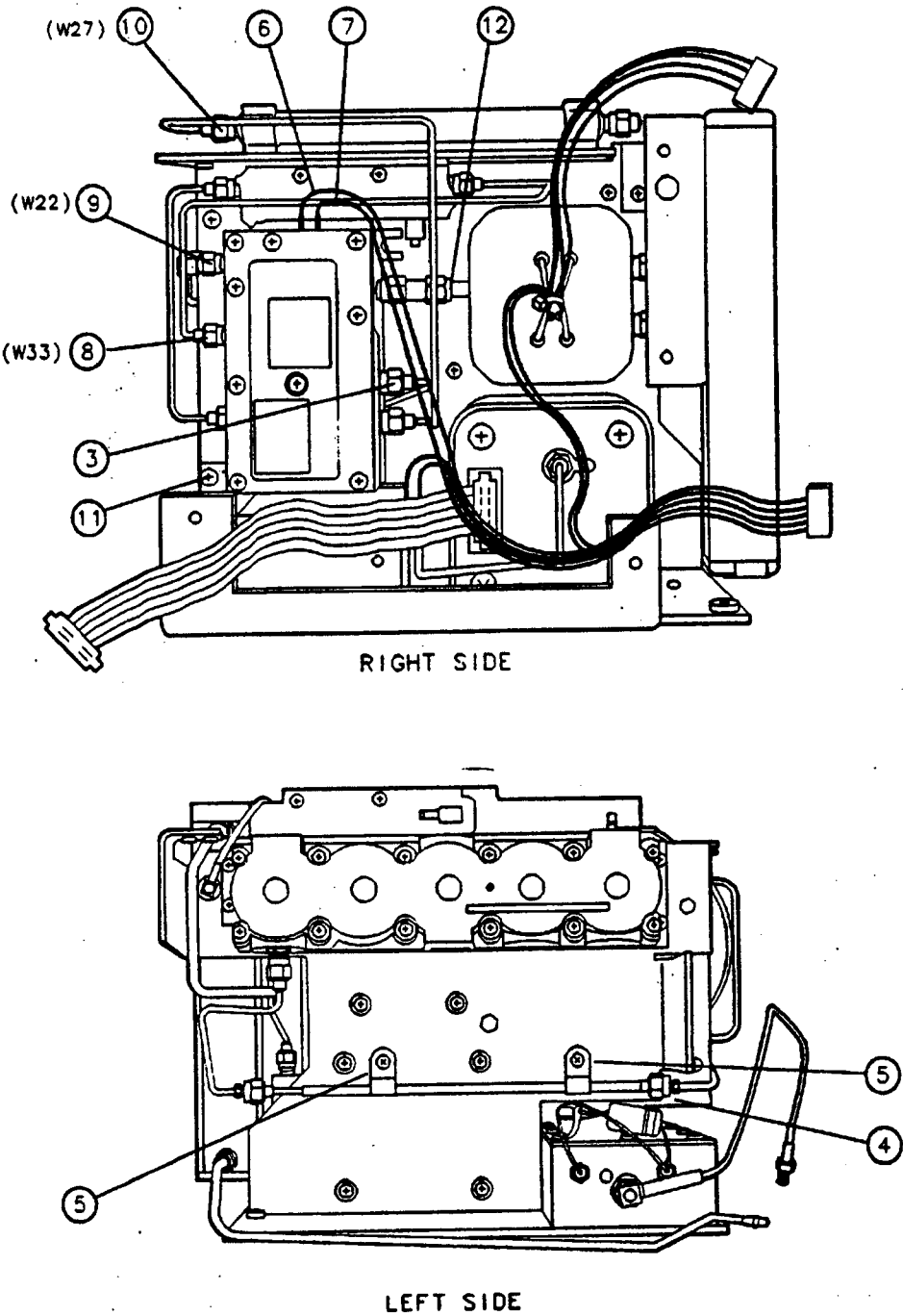

Figure 3-20. A3A6 Dual Mixer Replacement, Right and Left-Side Views

A3A6 Dual Mixer

Replacement

1. Attach the SMA adapter to A3A6J3 on the A3A6 Dual Mixer and tighten to 10 inch-pounds using a 5/16 inch torque wrench.
2. Connect the W29 semirigid cable to A3A6J2 without tightening.
3. Connect the W27 semirigid cable to A3A6J1 without tightening.
4. Place the A3 Front-End Assembly on the work surface with the right side facing up.

Caution

Protect the FL1 filter from being bent or twisted during the installation of the dual mixer.



5. Insert the dual mixer into the A3 Front-End Assembly. Carefully route the end of the W29 semirigid cable around to the "B" side of the front-end assembly. See Figure 3-20.
6. Hold the dual mixer in position and connect the SMA adapter at A3A2J2 (12) on the YTF assembly without tightening. See Figure 3-20.
7. Install the screw and washer (11) that secure the dual mixer to the standoff on the "A" bracket without tightening.
8. Torque the SMA connector at A3A2J2 (12) to 10 inch-pounds.
9. Tighten the screw (11) that secures the dual mixer to the standoff on the "A" bracket.
10. Connect the W27 semirigid cable (10) to the A3A3 Low-Pass Filter and tighten to 10 inch-pounds using a 5/16 inch torque wrench.
11. Connect the W22 coaxial cable (9) to A3A6J5 on the dual mixer and tighten to 10 inch-pounds using a 5/16 inch torque wrench.
12. Connect the W33 semirigid cable (8) to A3A6J4 on the dual mixer and tighten to 10 inch-pounds using a 5/16 inch torque wrench.
13. Dress the wiring that goes to the A3A1 Comb Generator beneath the lower-right corner of the dual mixer.
14. Connect the blue wire (6) and the green wire (7) to the dual mixer, using needle-nose pliers.
15. Place the front-end assembly on the work surface with the left side facing up.

Caution

The FL1 filter can be easily damaged. Avoid any action that causes the filter to bend or twist.



16. Connect W29 to the FL1 filter (4). If there is not enough clearance around the connector, remove the two screws (5) on the cable clamps that hold the filter in place.

Note

Hold the W29 connector firmly in position while tightening the connector nut on the filter. This reduces stress on the FL1 filter.



17. Tighten the FL1 filter connection (4) to 10 inch-pounds using a 1/4 inch wrench on the W29 connector and a 5/16 inch torque wrench on the FL1 connector.
18. If the two screws and washers (5) on the cable clamps were removed, replace and tighten them.
19. Place the front-end assembly on the work surface with the right side of the assembly facing up.
20. Tighten the W29 semirigid cable (3) at A3A6J2 on the dual mixer to 10 inch-pounds using a 5/16 inch torque wrench.
21. Dress the W12, W13, and W34 cables (1) out through the opening in the "D" bracket. See Figure 3-19.
22. Replace the "D" bracket and the five screws (2) that attach the bracket to the front-end assembly.
23. Replace the A3 Front-End Assembly. Refer to the "A3 Front-End Assembly" replacement procedure.
24. Replace the instrument cover assembly. Refer to the "Instrument Cover" replacement procedure.

A3A14 First LO Distribution Amplifier (Option 009, 010)

Caution Use ESD precautions when performing this replacement procedure.



Removal

Note Read the "Before Replacing the A3 Front-End Assembly" *before* performing this procedure.



1. Remove the instrument cover assembly. Refer to the "Instrument Cover" removal procedure.
2. Remove the A3 Front-End assembly. Refer to the "A3 Front-End Assembly" removal procedure.
3. Remove the A3A6 Dual Mixer. Refer to the "A3A6 Dual Mixer" removal procedure.
4. Disconnect the W31, W33 and W41 semirigid cables (1) from the A3A14 First LO Distribution Amplifier.
5. Disconnect the W20 coaxial cable (2) and W38 wire harness (2) from the A3A14 First LO Distribution Amplifier.
6. Remove the two screws (3) that secure the A3A14 First LO Distribution Amplifier to the "A" bracket.

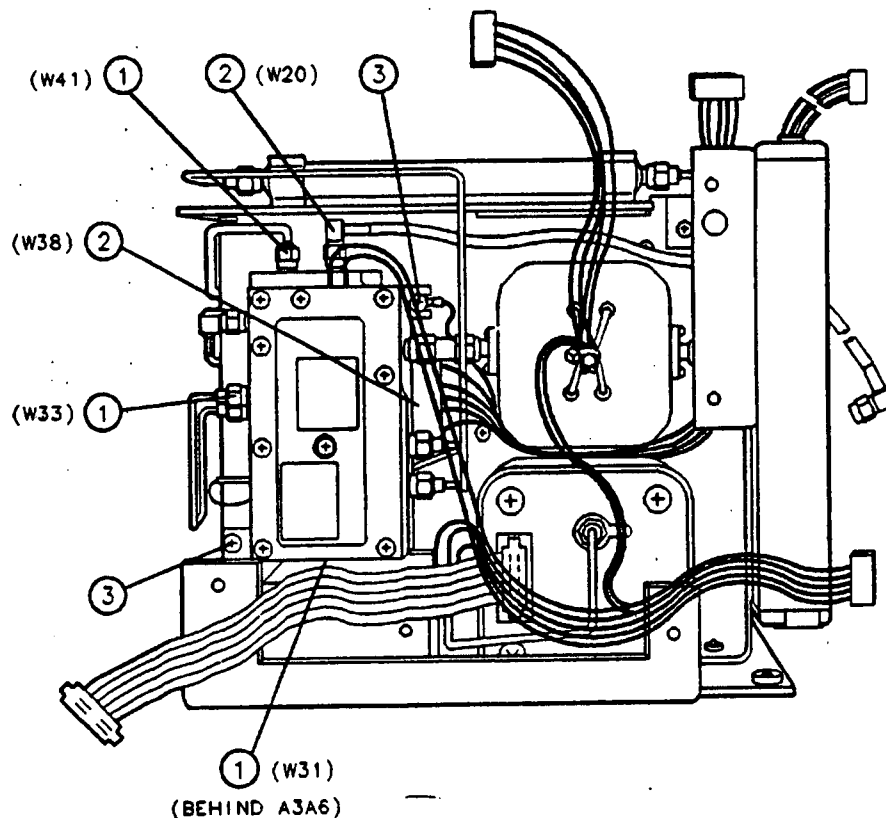

Figure 3-21. A3A14 First LO Distribution Amplifier Replacement

Replacement

1. Position the A3A14 First LO Distribution Amplifier on the "A" bracket.
2. Replace the two screws (3) that secure the A3A14 First LO Distribution Amplifier to the "A" bracket.
3. Connect the W20 coaxial cable (2) and W38 wire harness (2) to the A3A14 First LO Distribution Amplifier.
4. Connect the W31, W33 and W41 semirigid cables (1) to the A3A14 First LO Distribution Amplifier.
5. Replace the A3A6 Dual Mixer. Refer to the "A3A6 Dual Mixer" replacement procedure.
6. Replace the A3 Front-End assembly. Refer to the "A3 Front-End Assembly" replacement procedure.
7. Replace the instrument cover assembly. Refer to the "Instrument Cover" replacement procedure.

A3A13 Isolator

Caution Use ESD precautions when performing this replacement procedure.



Removal

Note Read the "Before Replacing the A3 Front-End Assembly" section of this chapter *before* performing this procedure.



1. Remove the instrument cover assembly. Refer to the "Instrument Cover" removal procedure.
2. Remove the A3 Front-End Assembly. Refer to the "A3 Front-End Assembly" removal procedure.

Caution The FL1 filter can be easily damaged. Avoid any action that causes the filter to bend or twist.



3. Remove the A3A6 Dual Mixer. Refer to the "A3A6 Dual Mixer" removal procedure.
4. Loosen, but do not remove, the W32 semirigid cable (1) at the A3A10 Directional Coupler. See Figure 3-22.
5. Disconnect W32 from the A3A13 Isolator (2).
6. Loosen the W31 semirigid cable (3) at the isolator.
7. Disconnect the W23 coaxial cable (4) from the A3A4 Second Converter.
8. Remove the screw (5) that secures the A3A1 Comb Generator to the "B" bracket.
9. Place the front-end assembly on the work surface with the right side facing out.
10. Remove the three screws (6) that secure the "B" bracket to the "A" bracket.
11. Carefully separate the "B" bracket from the "A" bracket at the front of the front-end assembly until the hardware for the isolator can be reached. Observe the following while separating the two brackets:
 - Separate the two brackets only at the front of the A3 Front-End assembly.
 - Slide the "B" bracket out from under the A3A1 Comb Generator (7) and over the W10 semirigid cable (8).
 - Pivot the "B" bracket around the W10 semirigid cable (9). The "B" bracket remains trapped by W10 and does not have to be removed from around W10 for this procedure.
 - Make sure that W10 does not interfere with W30 (10) while moving the "B" bracket.
12. Remove the two screws, lock-washers, and nuts (11) that secure the A3A13 Isolator to the "A" bracket, using a #0 Phillips screwdriver and needle-nose pliers.

- 13. Disconnect W31 (3) from the isolator.
- 14. Remove the isolator from the front-end assembly.

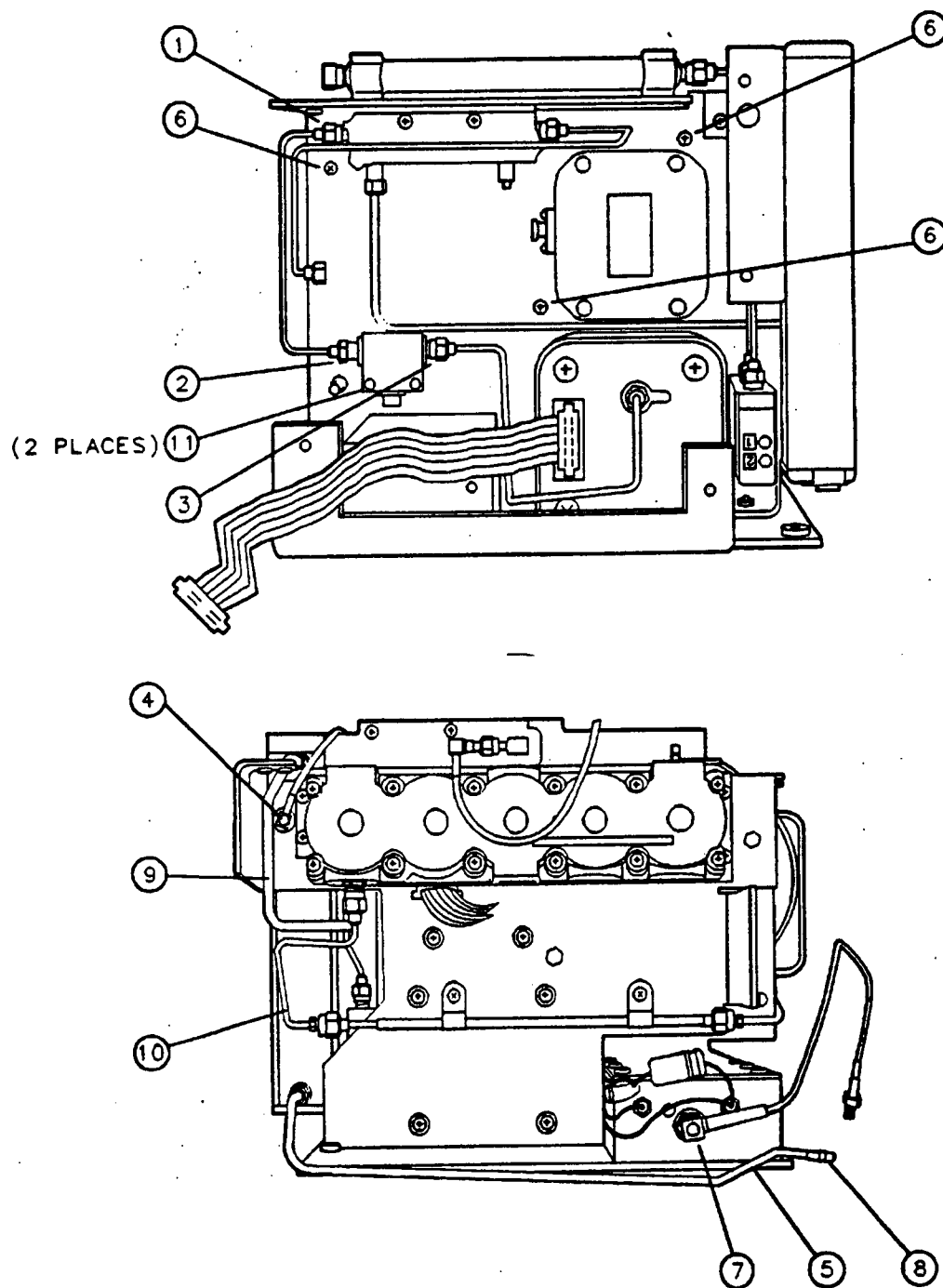

Figure 3-22. A3A13 Isolator Replacement

A3A13 Isolator

Replacement

1. Place the front-end assembly on the work surface with the right side facing out.
2. Note how each connector on the A3A13 Isolator is identified.
3. Position the isolator in the A3 Front-End Assembly with the label on the isolator facing the "A" bracket.
4. Connect the W31 semirigid cable (3) to the connector labeled "1" on the isolator, without tightening.
5. Replace the two screws, lock-washers, and nuts (11) that secure the isolator to the "A" bracket, using a #0 Phillips screwdriver and needle-nose pliers. Place the lock-washers and nuts on the isolator-side of the "A" bracket.
6. Carefully align the "B" bracket with the "A" bracket. Observe the following, while positioning the two brackets:
 - Make sure that W10 does not interfere with W30 (10) while moving the "B" bracket.
 - Pivot the "B" bracket around the W10 semirigid cable (9).
 - Slide the "B" bracket over the W10 semirigid cable (8) and under the A3A1 Comb Generator (7).
7. Replace the three screws (6) that secure the "B" bracket to the "A" bracket.
8. Replace the screw (5) that secures the A3A1 Comb Generator to the "B" bracket.
9. Connect the W23 coaxial cable (4) to the A3A4 Second Converter.
10. Tighten W31 (3) to 10 inch-pounds, using a 5/16 inch torque wrench.
11. Connect the W32 semirigid cable (2) to the isolator and tighten to 10 inch-pounds.
12. Tighten W32 (1) at the A3A10 Directional Coupler to 10 inch-pounds.
13. Replace the A3A6 Dual Mixer. Refer to the "A3A6 Dual Mixer" replacement procedure.
14. Replace the A3 Front-End Assembly. Refer to the "A3 Front-End Assembly" replacement procedure.
15. Replace the instrument cover assembly. Refer to the "Instrument Cover" replacement procedure.

A3A10 Directional Coupler

Caution Use ESD precautions when performing this replacement procedure.



Removal

Note Read the "Before Replacing the A3 Front-End Assembly" section of this chapter *before* performing this procedure.



1. Remove the instrument cover assembly. Refer to the "Instrument Cover" removal procedure.
2. Remove the A3 Front-End Assembly. Refer to the "A3 Front-End Assembly" removal procedure.
3. Place the A3 Front-End Assembly on the work surface with the right side of the assembly facing up.
4. Note the cable dress of W12, W13, and W34 (1) that pass through the opening in the "D" bracket. See Figure 3-23. (This information is used later, during the directional coupler replacement procedure.)
5. Loosen, but do not disconnect, the W29 semirigid cable (2) from A3A6J2 on the dual mixer.
6. Remove the five screws (3) that hold the "D" bracket in place and remove the bracket.

A3A10 Directional Coupler

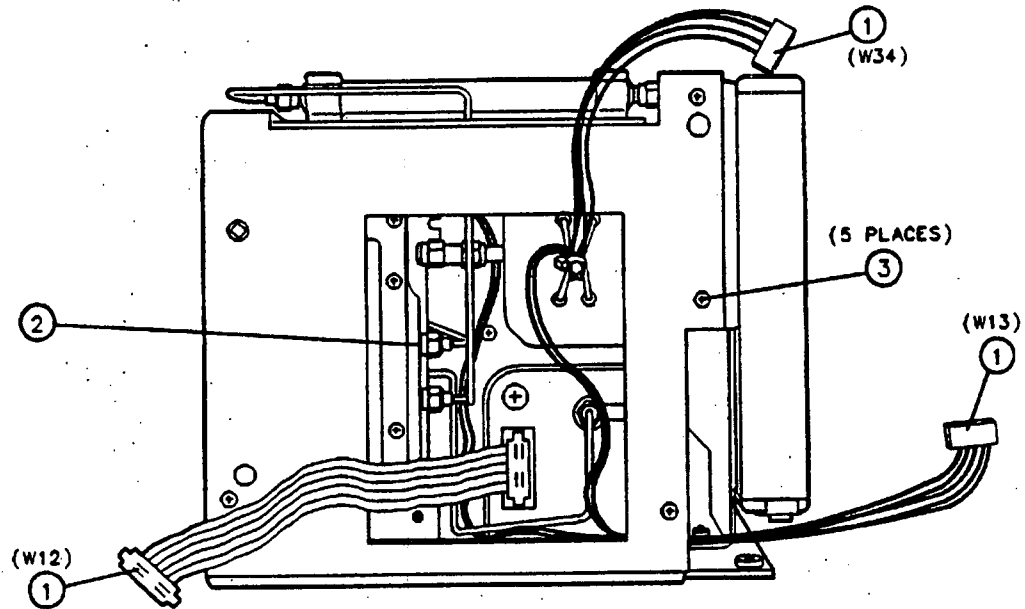

Figure 3-23. A3A10 Directional Coupler Replacement, Right-Side View

7. Place the front-end assembly on the work surface with the left side facing up.

Caution



The FL1 filter can be easily damaged. Avoid any action that causes the filter to bend or twist.

8. If there is not enough clearance for the use of wrenches at the W29 connector (4), remove the two screws and flat washers (5) on the cable clamps that hold the filter in place. See Figure 3-24.

Note



Hold the W29 connector firmly in position while loosening the connector nut on the filter. This reduces stress on the FL1 filter.

9. Disconnect W29 (4) from the FL1 filter using a 1/4 inch wrench on the W29 connector and a 5/16 inch wrench on the FL1 connector.
10. Disconnect the W23 coaxial cable (6) from the A3A4 Second Converter.
11. Remove the screw (7) that secures the A3A1 Comb Generator to the "B" bracket.

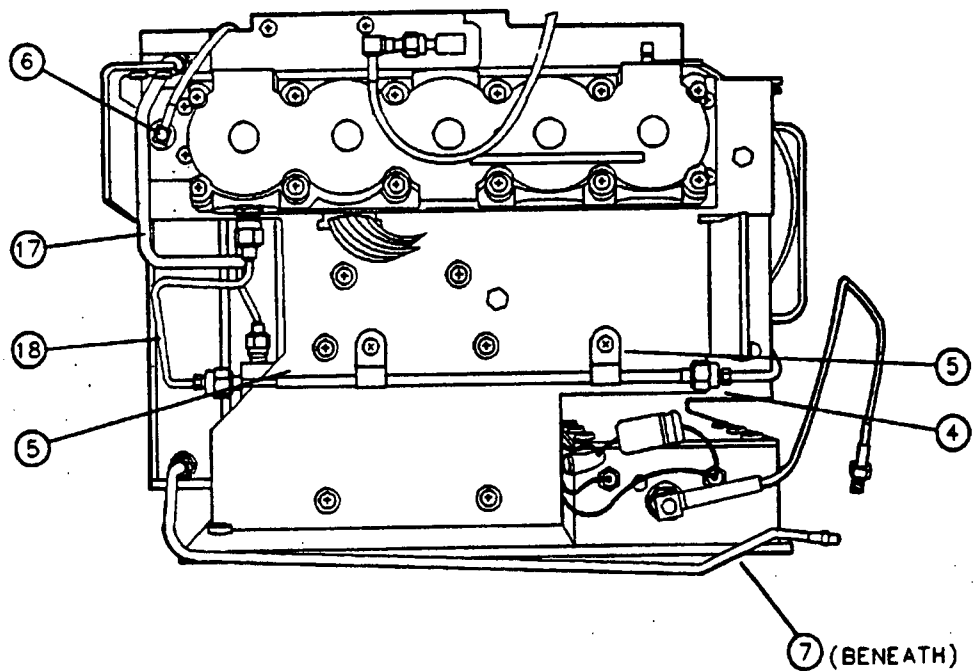

Figure 3-24. A3A10 Directional Coupler Replacement, Left-Side View

12. Place the front-end assembly on the work surface with the front of the assembly facing out.
13. Disconnect the W33 semirigid cable (8) from A3A6J4 on the dual mixer. See Figure 3-25.
14. Disconnect the W22 coaxial cable (9) from A3A6J5 on the dual mixer.
15. Loosen the W20 coaxial cable (10) from the directional coupler. Note how W20 is routed through the front-end assembly.
16. Loosen the W32 semirigid cable (11) at the directional coupler.
17. Disconnect the W32 semirigid cable (12) from the A3A13 Isolator.
18. Remove the three screws (13) that secure the "B" bracket to the "A" bracket.

A3A10 Directional Coupler

19. Carefully separate the "B" bracket from the "A" bracket at the front of the front-end assembly until the hardware for the directional coupler can be reached. Observe the following while separating the two brackets:
 - Position the W29 semirigid cable (14) so that it does not interfere with the separation of the two brackets.
 - Separate the two brackets only at the front of the A3 Front-End assembly.
 - Slide the "B" bracket (15) out from under the A3A1 Comb Generator and over the W10 semirigid cable (16).
 - Pivot the "B" bracket around the W10 semirigid cable (17). See Figure 3-24. The "B" bracket remains trapped by W10 and does not have to be removed from around the cable for this procedure.
 - Make sure that W10 does not interfere with W30 (18) while moving the "B" bracket.
20. Remove the two screws, lock-washers, and nuts (19) that secure the A3A10 Directional Coupler to the "A" bracket, using a small Pozidrive screwdriver and needle-nose pliers. See Figure 3-25.
21. Pull the directional coupler (20) out from behind the A3A6 Dual Mixer and disconnect the W20 coaxial cable (10). Leave W20 in the front-end assembly.
22. After removing the directional coupler, disconnect the W32 (11) and W33 (21) semirigid cables.

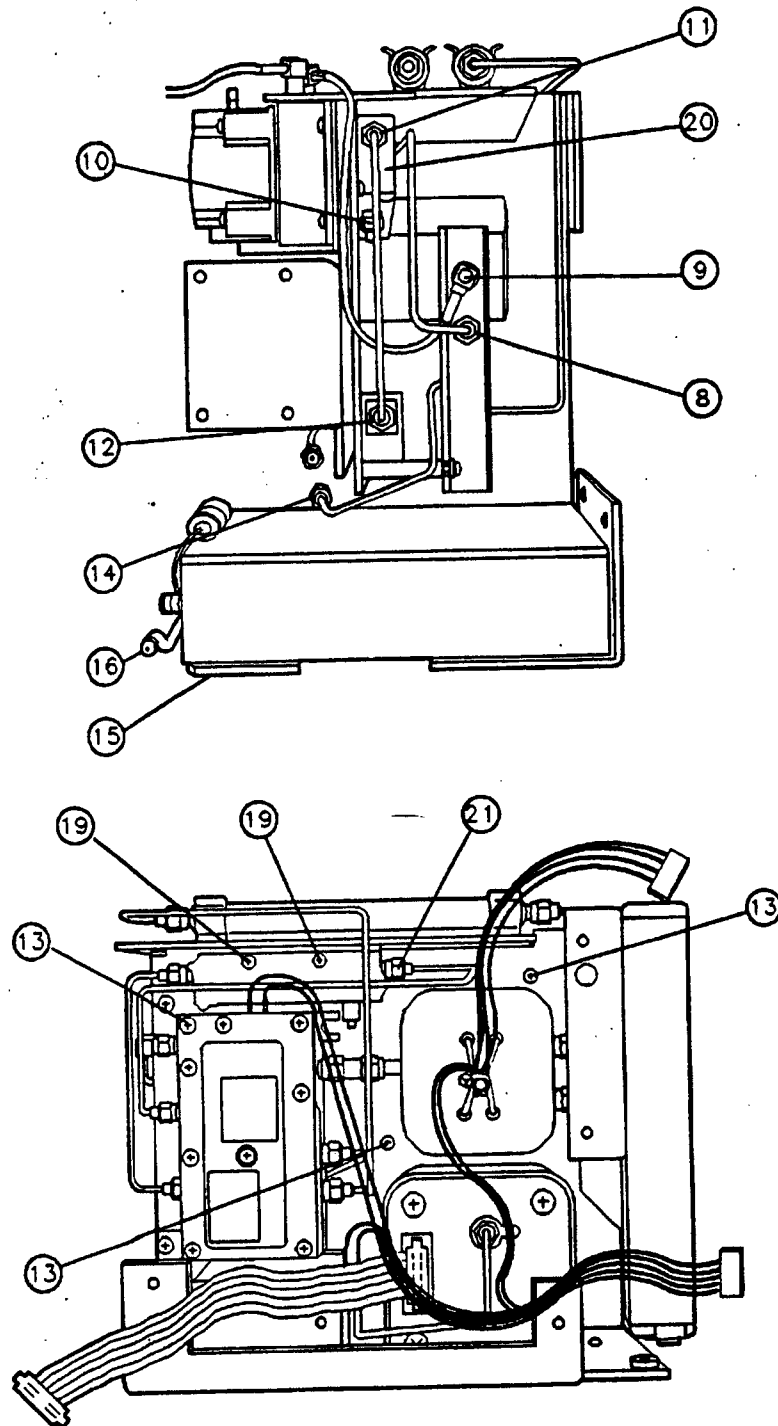

Figure 3-25. A3A10 Directional Coupler Replacement, Front and Right-Side Views

A3A10 Directional Coupler

Replacement

1. Connect the W32 semirigid cable to the A3A10 Directional Coupler without tightening. See Figure 3-25.
2. Connect the W33 cable to the input of the directional coupler. Make sure the cable is connected so that the label on the directional coupler faces the "A" bracket when installed in the front-end assembly.
3. Place the front-end assembly on the work surface with the front of the assembly facing out.
4. Before installing the directional coupler in the front-end assembly, connect the W20 coaxial cable to the directional coupler. Tighten W20 to 10 inch-pounds with a 5/16 inch torque wrench.
5. Position the directional coupler (20) in the front-end assembly. Make sure that W20 is correctly routed through the front-end assembly, as noted in the directional-coupler removal procedure.
6. Replace the two screws, lock-washers, and nuts (19) that secure the directional coupler to the "A" bracket, using a small Pozidrive screwdriver and needle-nose pliers. The lock-washers and nuts should be against the "B" bracket.
7. Carefully align the "B" bracket with the "A" bracket. Observe the following while mating the two brackets:
 - Make sure that W10 does not interfere with W30 (18) while moving the "B" bracket. See Figure 3-24.
 - Pivot the "B" bracket around the W10 semirigid cable (17).
 - Slide the "B" bracket over the W10 semirigid cable (16) and under the A3A1 Comb Generator (15). See Figure 3-25.
 - Position the W29 semirigid cable (14) so that it does not interfere with the alignment of the two brackets.
8. Replace the three screws (13) that secure the "B" bracket to the "A" bracket.
9. Connect the W32 semirigid cable (12) to the A3A13 Isolator and tighten to 10 inch-pounds, using a 5/16 inch torque wrench.
10. Tighten the W32 semirigid cable (11) at the directional coupler to 10 inch-pounds.
11. Tighten the W33 semirigid cable (21) at the directional coupler to 10 inch-pounds.
12. Connect the W22 coaxial cable (9) to A3A6J5 on the dual mixer and tighten to 10 inch-pounds.
13. Connect the W33 semirigid cable (8) to A3A6J4 on the dual mixer and tighten to 10 inch-pounds.
14. Replace the screw (7) that secures the comb generator the "B" bracket. See Figure 3-24.
15. Place the front-end assembly on the work surface with the left side facing up.
16. Connect the W23 coaxial cable (6) to the A3A4 Second Converter.

Caution



The FL1 filter can be easily damaged. Avoid any action that causes the filter to bend or twist.

17. Connect W29 (4) to the FL1 filter, without tightening.

Caution



Hold the W29 connector firmly in position with a 1/4 inch wrench while tightening the connector nut on the filter. This reduces stress on the FL1 filter.

18. Tighten W29 (4) to 10 inch-pounds.

19. If the two screws and flat washers (5) on the cable clamps were removed, replace them.

20. Place the A3 Front-End Assembly on the work surface with the right side of the assembly facing up.

21. Route the W12, W13, and W34 wire-harnesses (1) through the opening in the "D" bracket. See Figure 3-23.

22. Position the "D" bracket on the "A" bracket and replace the five screws (3) that hold the "D" bracket in place.

23. Tighten the W29 semirigid cable (2) at A3A6J2 on the dual mixer to 10 inch-pounds.

24. Replace the A3 Front-End Assembly. Refer to the "A3 Front-End Assembly" replacement procedure.

25. Replace the instrument cover assembly. Refer to the "Instrument Cover" replacement procedure.

A7 Analog Interface Assembly

Caution Use ESD precautions when performing this replacement procedure.



Removal

1. Remove the instrument cover assembly. Refer to the "Instrument Cover" removal procedure.

Note The next step requires a Torx screwdriver with a T8 bit.



2. Remove the four screws (1), which secure the A7 Analog Interface assembly to the right side of the instrument chassis. See Figure 3-26.
3. Note how the cables and wiring attached to the A7 assembly are dressed. (This information will be used later during the replacement procedure.)

Note If the instrument came equipped with an LO Output on the rear panel (Option 009), disconnect W42 from the LO OUTPUT connector on the rear-frame assembly (2).



4. Pull the A7 assembly partially out of its slot and disconnect W12, W13, W34, W35, and W36 from the A7 assembly (3).
5. Remove the A7 assembly and place it in a static-safe container.

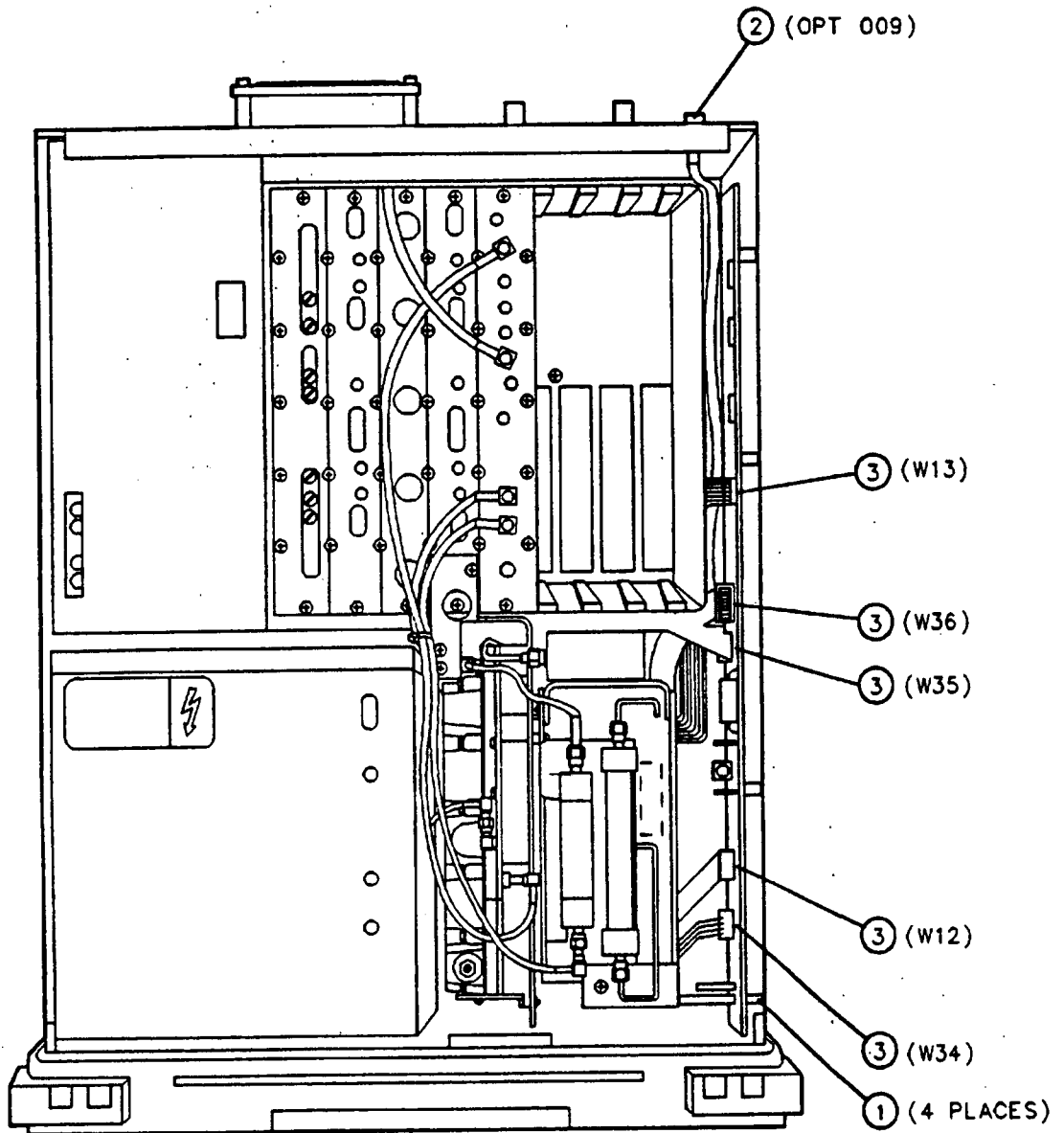

Figure 3-26. A7 Analog Interface Assembly Replacement

A7 Analog Interface Assembly

Replacement

Caution



Serious instrument damage will result if any wire connector is not installed correctly. A connector can be installed backwards or in the wrong position. Inspect each connector and make sure it is not damaged or missing a key plug. Also inspect the A7 assembly for bent connector pins. Incorrect connector installation is most likely to occur with the connectors on W12, W35 and W36. See Figure 3-27.

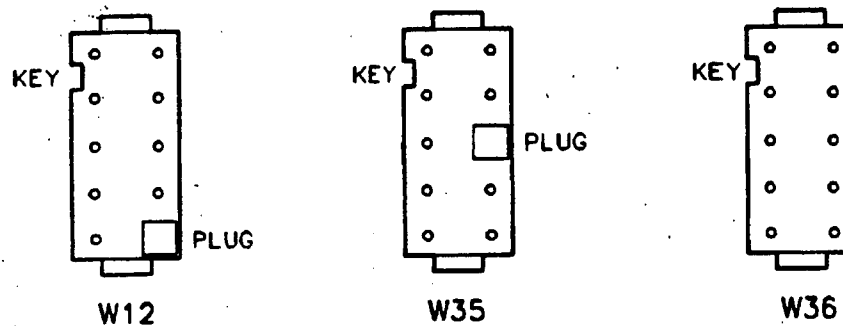

Figure 3-27. End View of Connectors for W12, W35, and W36

1. Lower the A7 assembly part way into the A7 slot and connect W12 and W34 (3) to the A7 assembly.

Note



If the instrument came equipped with an LO Output on the rear panel (Option 009), connect W42 to the LO OUTPUT connector on the rear-frame assembly (2).

Note



To ensure proper installation of the A7 assembly, perform the following:

- a. Arrange W42 below W13 (3) and W36 (3), between the A7 assembly and the IF card cage.
 - b. Arrange all wiring so that the wires do not press against the A7 assembly.
 - c. Align the two tabs on the bottom of the A7 assembly with the slots on the instrument chassis.
 - d. Avoid bending the pins on the A15 Motherboard connector while positioning the A7 assembly.
 - e. Align the A7 Analog Interface assembly connector with the A15 Motherboard connector carefully.
2. Install the A7 assembly. Slide the A7 assembly toward the back of the A7 slot so that the front-end-to-chassis spacer, mounted on the leading edge of the A7 assembly, will drop smoothly into place.

3. Install W13, W35, and W36 (3) on the A7 assembly.

Note

The next step requires a Torx screwdriver with a T8 bit.



4. Replace the four screws (1) that secure the A7 assembly to the right side of the chassis.
5. Replace the instrument cover assembly. Refer to the "Instrument Cover" replacement procedure.

A8 Power Supply

Removal

1. Remove the instrument cover assembly. Refer to the "Instrument Cover" removal procedure.
2. Remove the instrument rear frame. Refer to the "Rear-Frame Assembly" removal procedure.

Note The next step requires a Torx screwdriver with a T8 bit.



-
3. Remove the four Torx screws and washers on the left side of the chassis adjacent to the A8 Power Supply.
 4. Grasp the power supply pull-tab (1), pull straight up, and remove the A8 assembly from the instrument chassis. See Figure 3-28.

Replacement

1. Lower the A8 assembly into the instrument chassis. The two alignment pins (2) on the power-supply connector provide the proper mating with the A15 Motherboard connector. Reposition the A8 assembly back or forward until it drops into place.
2. With the connectors properly aligned, push down on top of the A8 assembly close to the pull tab (3). The assembly is correctly installed when the four mounting holes on the left side of the chassis are aligned with the tapped holes on the A8 assembly.

Note The next step requires a Torx screwdriver with a T8 bit.



-
3. Replace the four Torx screws and washers on the left side of the chassis.
 4. Replace the rear frame. Refer to the "Rear-Frame Assembly" replacement procedure.
 5. Replace the instrument cover assembly. Refer to the "Instrument Cover" replacement procedure.

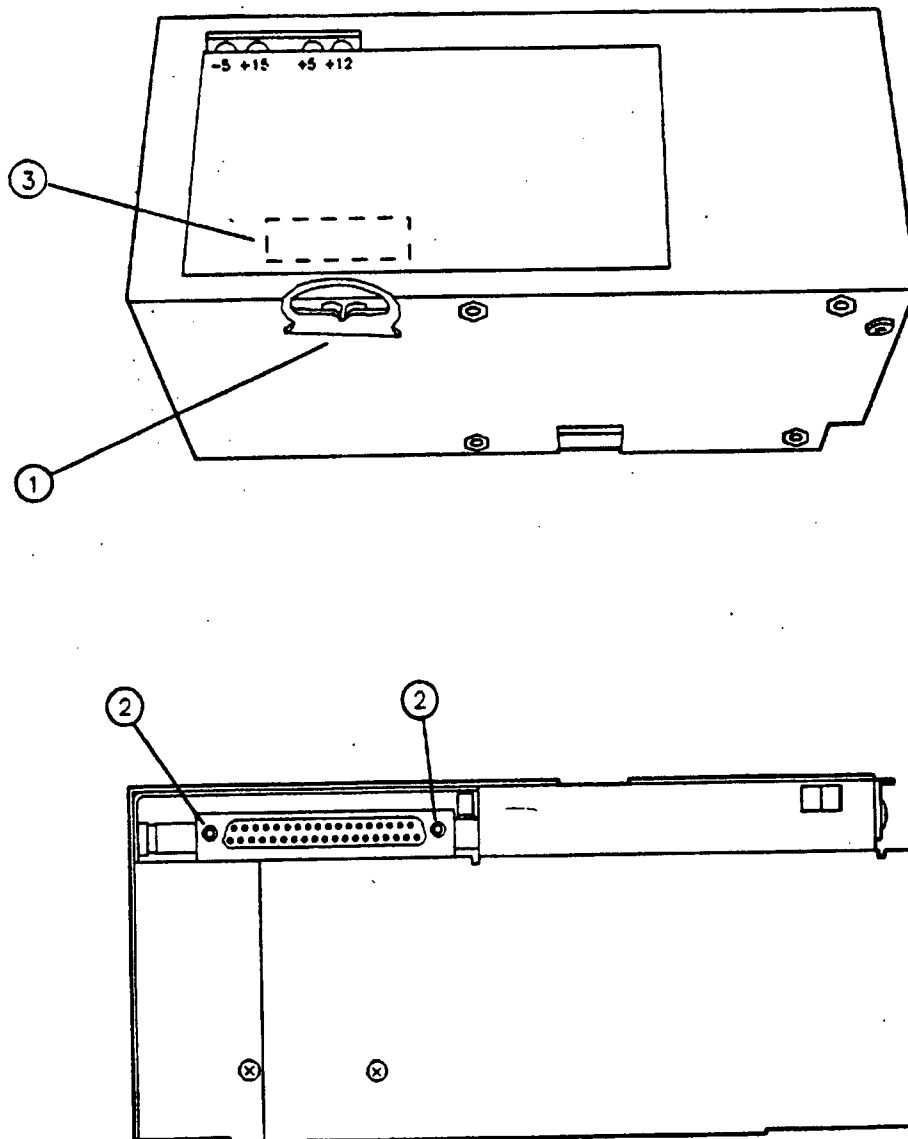

Figure 3-28. A8 Power Supply Replacement

A15 Motherboard and IF Extrusion

Caution Use ESD precautions when performing this replacement procedure.



Removal of the A15 Motherboard

1. Remove the instrument cover assembly. Refer to the "Instrument Cover" removal procedure.
2. Remove the A8 Power Supply. Refer to the "A8 Power Supply" removal procedure.

Note If there are options installed in the card cage, perform the following:



- Note how the wiring and cables to each option are dressed.
- Remove all cable ties.
- Disconnect all cables and wire harnesses attached to each option.
- Remove the option assemblies from the card cage.

-
3. Remove W7, W8, W9 and W21 (1) from the A9 Third Converter. See Figure 3-29.

Note This procedure requires a Torx screwdriver with a T8 bit.



-
4. Remove the four screws and flat washers (2) that secure the A7 Analog Interface assembly to the right side of the instrument chassis.
 5. Note how the wiring attached to the A7 assembly is dressed. (This information will be used later during the A15 Motherboard Assembly replacement procedure.)
 6. Pull the A7 assembly partially out of its slot and disconnect W12, W13, W34, W35, and W36 (3) from the A7 assembly.
 7. Remove the A7 assembly and place it in a static-safe container.
 8. Remove the two screws (4) on the front-end-to-IF support bracket.
 9. Disconnect the W19 coaxial cable (5) from the A15J18 at the rear of the instrument. See Figure 3-30.
 10. Disconnect the B1 Fan wire harness (6) from A15J19 at the rear of the instrument.
 11. Remove the 40 screws (7) that secure the five IF board assemblies in the IF extrusion assembly.

Caution Use the two-prong board-puller tool to remove the IF board assemblies that do not have attached covers. Traces on the printed circuit boards can be damaged if tools with sharp edges are used to remove the IF board assemblies.



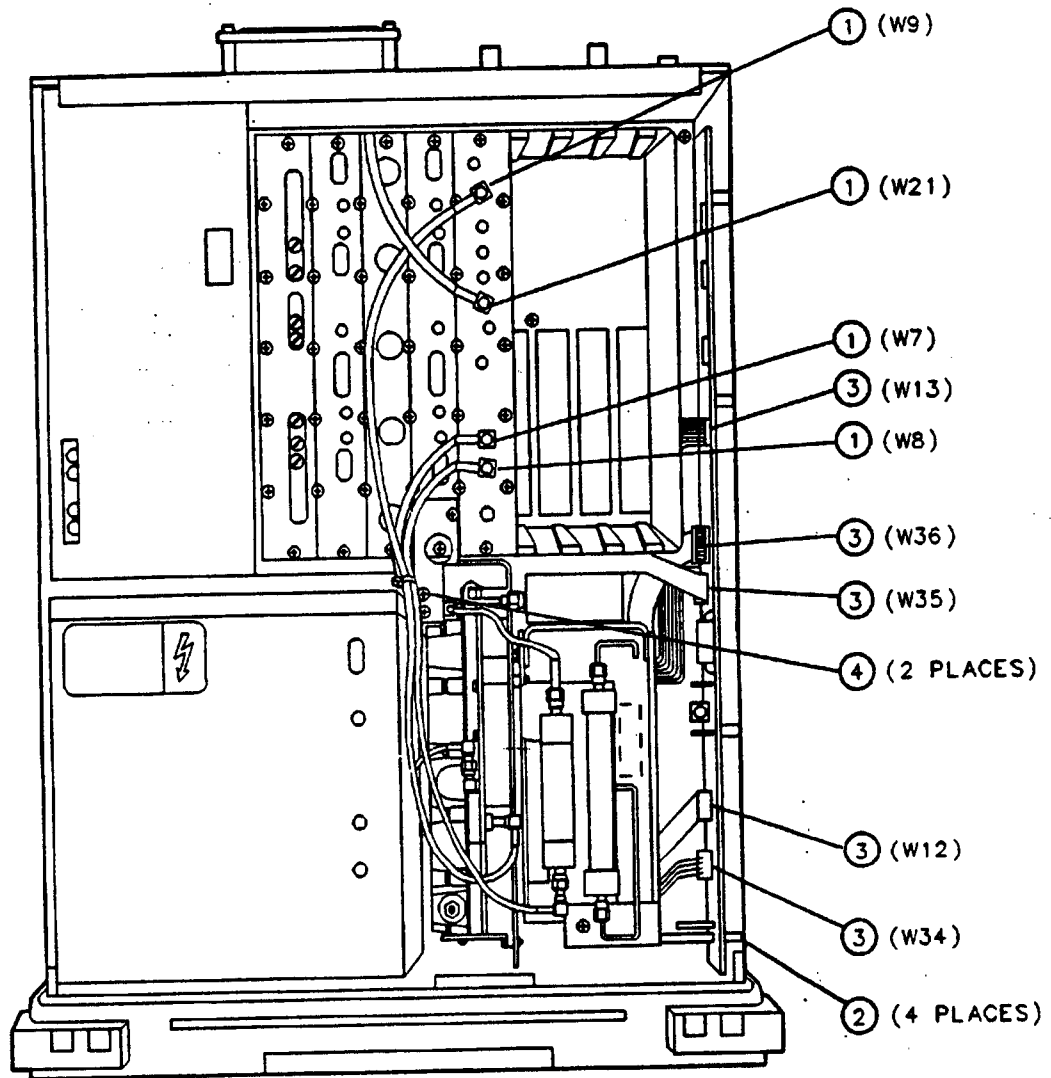

Figure 3-29. A15 Motherboard Replacement

12. Remove the five IF board assemblies (8) from the IF extrusion and place them in a static-safe container.
13. Remove the five screws (9) that secure the A15 Motherboard to the instrument chassis.

Caution



Do not twist the motherboard sideways while removing it from the instrument. This avoids damaging the connector on the A16 Processor/Video Board Assembly that is mated with the connector on the back side of the A15 Motherboard.

14. Pull the motherboard straight up and out of the instrument chassis. If the motherboard is difficult to remove, a slight rocking action, from front to rear, will help it disconnect from the connector on the processor/video board assembly.

A15 Motherboard and IF Extrusion

15. Remove the four screws (10) that secure the card-cage bracket to the sides of the IF extrusion.
16. Turn the motherboard assembly upside down on the work surface and remove the two screws (11) that secure the card-cage bracket to the motherboard. Remove the bracket.
17. Remove the 40 screws (12) that secure the IF extrusion assembly to the motherboard.

Note

If you are replacing a defective A15 Motherboard, continue at the "Replacement of the A15 Motherboard" procedure.

18. Remove the motherboard and place it in a static-safe container.

A15 Motherboard and IF Extrusion

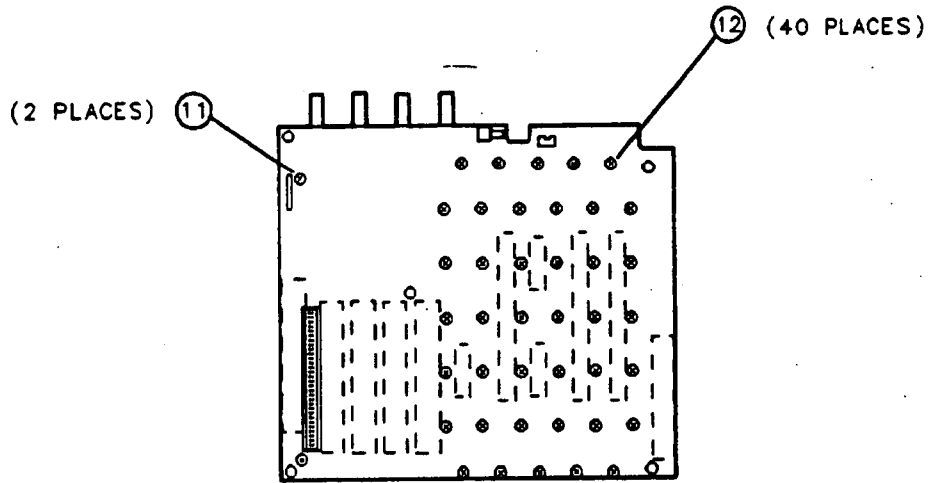
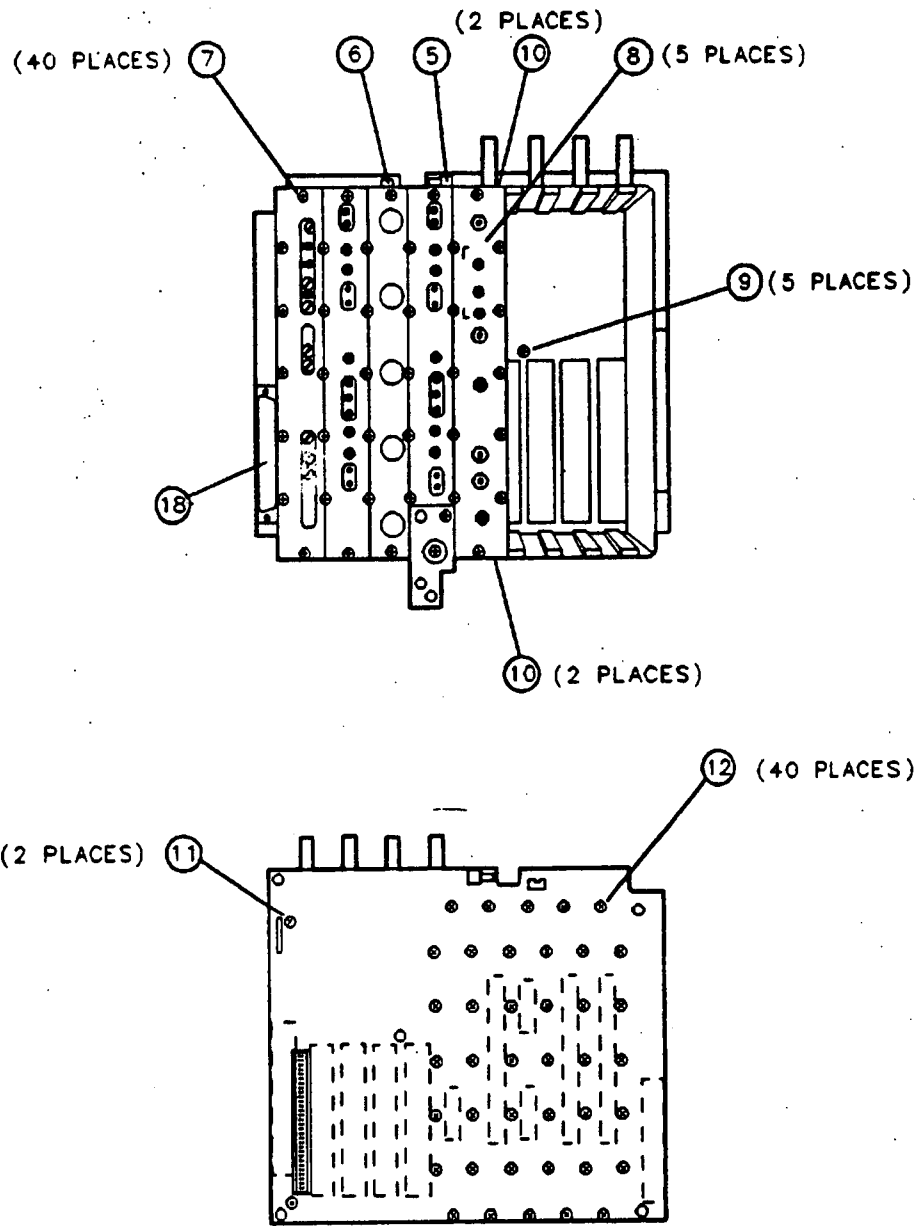

Figure 3-30. A15 Motherboard with IF Section

A15 Motherboard and IF Extrusion

Removal of Individual Sections on the IF Extrusion Assembly

Caution



While separating sections of the IF extrusion, protect the top and bottom finished surfaces of each extrusion section (13) from damage. See Figure 3-31.

19. Separate individual sections of the IF extrusion, as required, by sliding them apart, one at a time. The sections fit together tightly and must be forced apart.
20. Place the extrusion assembly on a solid, level work surface with the slots facing up.
21. Position the assembly so that the joints (14) of the extrusion section to be removed extend out over the edge of the work surface.

Caution



When sliding extrusion sections apart, use a soft-faced hammer to protect the surface of the extrusion assembly. If only a hard-faced hammer is available, use blocks, made of plastic or wood, to protect the extrusion surface.

22. Make sure that the portion of the extrusion assembly resting on the table is held firmly in place.
23. Alternately strike each corner (15) of the extrusion section with a soft-faced hammer, until the extrusion sections slide apart. Strike directly on the corners with light to moderate force.
24. Repeat the previous three steps for each extrusion section that must be removed.

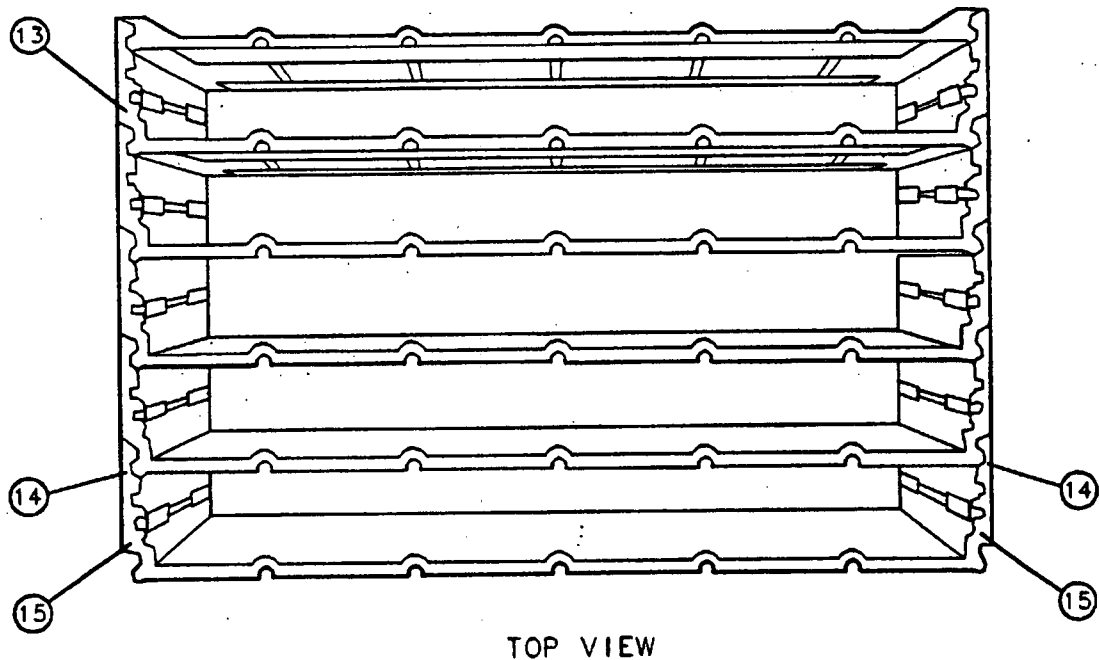

Figure 3-31. IF Extrusion Assembly Replacement

Replacement of Individual Sections of the IF Extrusion

Assembly

Caution



When replacing sections of the IF extrusion, protect the top and bottom finished surfaces (13) of the extrusion sections from damage. See Figure 3-31.

1. Place the incomplete extrusion assembly on a solid, level work surface with its IF board assembly slots facing up. Make sure the work surface is clean so that it will not damage the bottom surface of the extrusion assembly.
2. Place a single extrusion section next to the incomplete extrusion as shown in Figure 3-32.
3. Interlock the joint (1) of the single extrusion section with the joint on the incomplete extrusion assembly.
4. Position the other joint (2) of the single extrusion section against the joint on the extrusion assembly.
5. Squeeze the two adjoining extrusion sections together at the center of each section (3). Press with both hands, using moderate force, until the joint (2) of the single extrusion section snaps into place on the extrusion assembly.
6. Repeat the previous four steps, replacing the extrusion sections one at a time, until the extrusion assembly is complete.
7. All extrusion sections must be level with each other. Place a metal straight-edge across the finished surface of the extrusion assembly and check the level of each extrusion section. Use a soft-faced hammer to reposition extrusion sections, as needed.

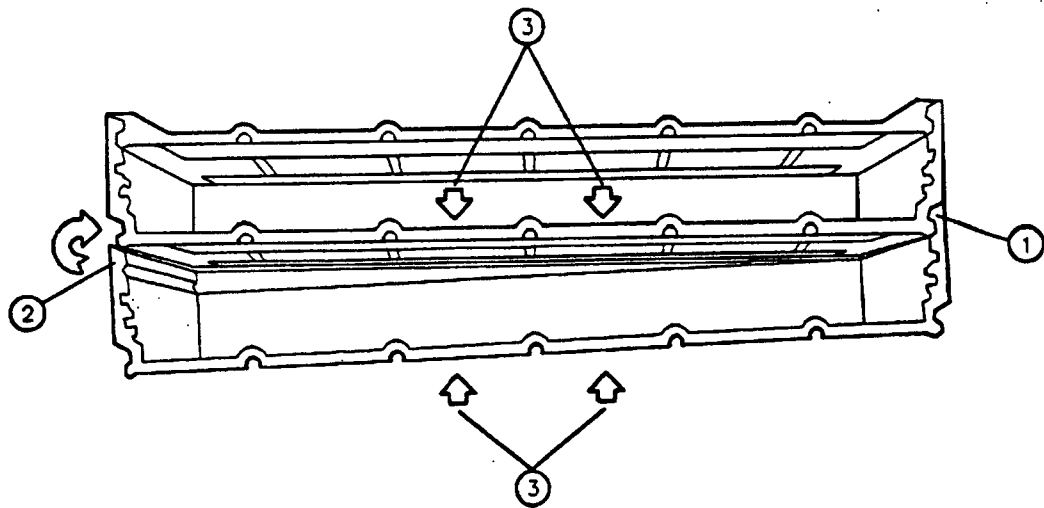

Figure 3-32. IF Extrusion Section Replacement

A15 Motherboard and IF Extrusion

Replacement of the A15 Motherboard

8. Position the IF extrusion assembly on the work surface with its IF board assembly slots facing up. There is no "top" or "bottom" to the IF extrusion; it can be installed with either finished surface mated to the A15 Motherboard.
9. Make sure that the mating surfaces of the extrusion assembly and the motherboard are free of debris.

Note

The IF extrusion assembly contains one flat extrusion end-section. Make sure that the extrusion assembly is positioned with the flat extrusion end-section next to the A8 Power Supply connector (18). See Figure 3-30.

10. Turn the A15 Motherboard upside down and align it with the IF extrusion assembly.

Caution

The screws used on the IF extrusion produce metal filings as they are screwed into the extrusion. Make sure that the motherboard is held tightly to the IF extrusion so that no metal filings will be caught between the two mating surfaces.

11. Replace the 40 screws (12) that secure the IF extrusion assembly to the motherboard.
12. While the extrusion assembly remains upside down, remove any metal filings from the extrusion slots using compressed air or a long-handled brush.
13. Replace the card-cage bracket and align it with the two holes on the motherboard.
14. Replace the two screws (11) that secure the card-cage bracket to the motherboard without tightening.
15. Turn the motherboard assembly right side up and replace the four screws (10) that secure the card-cage bracket to the sides of the IF extrusion assembly.
16. Tighten the two screws (11) on the bottom-side of the motherboard.

Caution

Do not twist the motherboard sideways while inserting its connector into the A16 board assembly connector. This prevents damage to either connector.

17. Lower the motherboard assembly into the instrument chassis and align it with the connector on the processor/video board assembly.
18. If it is difficult to insert the motherboard connector into the processor/video connector, a slight rocking action, from front to rear, will help it drop into place.
19. Make sure that the holes in the motherboard assembly line up with the holes in the instrument chassis.

Note

If the holes do not line up, loosen the screws that secure the A16 Processor/Video Board Assembly to the instrument chassis. Refer to the "A16 Processor/Video Board Assembly" replacement procedure.

20. Replace the five screws (9) that secure the A15 Motherboard to the instrument chassis.

21. Replace the five IF board assemblies (8) in the IF extrusion.
22. Place each IF cover over its corresponding IF board assembly.
23. Replace the 40 screws (7) that secure the IF board assemblies to the IF extrusion.
24. Connect the B1 Fan wire harness (6) to A15J19 at the rear of the motherboard.
25. Connect the W19 coaxial cable (5) on A15J18 at the rear of the motherboard.
26. Replace the two screws and flat washers (4) on the front-end-to-IF support bracket. See Figure 3-29.
27. Lower the A7 Analog Interface assembly part of the way into the A7 slot.

Caution



Serious instrument damage will result if any wire connector is not installed correctly. A connector can be installed backwards or in the wrong position. Inspect each connector and make sure it is not damaged or missing a key plug. Also inspect the A7 assembly for bent connector pins. This problem is most likely for the connectors on W12, W35 and W36. See Figure 3-33.

28. Connect W12 and W34 to the A7 assembly (3).

Note



Perform the following to ensure proper installation of the A7 assembly:

- Arrange all wiring so that it does not press against the A7 assembly.
- Correctly align the two tabs on the bottom of the A7 assembly with the slots on the instrument chassis.
- Take care to avoid bending the pins on the A15 Motherboard connector while positioning the A7 assembly.
- Correctly align the A7 assembly connector with the connector on the A15 Motherboard.

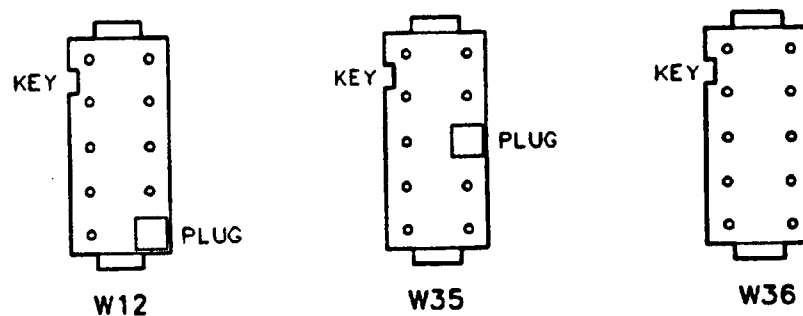

Figure 3-33. Connector Key Position on W12, W35, and W36

29. Install the A7 assembly completely, then connect W13, W35, and W36 (3).

A15 Motherboard and IF Extrusion

Note

The next step requires a Torx screwdriver with a T8 bit.



30. Install the four screws and flat washers (2) that secure the A7 assembly to the right side of the instrument chassis.
 31. Replace W7, W8, W9, and W21 (1) on the A9 Third Converter.
-

Note

If the instrument is equipped with card-cage options, perform the following:



- Replace the option assemblies in the card-cage slot that they were removed from.
 - Connect all option cables and wire harnesses as noted in the removal procedure.
 - Replace all cable ties as noted in the removal procedure.
 - Position all wiring and cables so that they do not interfere with the installation of the instrument cover.
-

32. Replace the A8 Power Supply. Refer to the "A8 Power Supply" replacement procedure.
33. Replace the instrument cover assembly. Refer to the "Instrument Cover" replacement procedure.

A16 Processor/Video Board Assembly

Before Replacing the A16 Processor/Video Board Assembly

Frequency response and cal attenuator correction constants (for the A12 Amplitude Control Board Assembly) are stored in battery-backed RAM on the A16 Processor/Video Board Assembly. Prior to removing the A16 assembly, record these correction constants using the following procedure.

Note

If you are unable to perform the following steps or the current correction constants are invalid, new correction constants must be generated *after* replacing the board assembly. Refer to the "10 MHz Reference (Standard)," "Frequency Response," and "Cal Attenuator Error Correction" adjustment procedures in Chapter 2 of this manual.

If valid correction constants can be removed from analyzer memory before replacing the A16 assembly, record the correction values using the following procedures from "Backing Up Correction Constants" in Chapter 9.

1. Use the "Retrieving the Timebase and Flatness-Correction Constants" procedure to record the timebase and flatness correction constants.
2. Use the "Retrieving the A12 Step-Gain Correction Constants" procedure to record the step gain correction constants.
3. Return to this chapter and perform the removal procedure for the A16 assembly.

A16 Processor/Video Board Assembly

Caution Use ESD precautions when performing this replacement procedure.



Removal

1. Remove the instrument cover assembly. Refer to the "Instrument Cover" removal procedure.
 2. Place the analyzer on the work surface with the bottom side facing up.
 3. Detach the instrument rear frame from the chassis. Pull the rear frame back so that the A16 Processor/Video Board Assembly is completely exposed.
 4. Disconnect the W14 ribbon cable (1) from A16J2 and A25J4. See Figure 3-34.
 5. Remove the 4 screws (2) that secure the A25 Counter-Lock Assembly.
 6. Remove the A25 assembly (3).
-

Note For Option 021 or 023 only:



- Remove the four screws (4) that secure the A20 or A21 IO Board Assembly.
 - Remove the A20 or A21 I/O Board Assembly (5).
-

7. Remove the nine screws (6) that secure the A16 assembly.
-

Caution The A16 assembly may be damaged if it is placed on a conductive surface. Use a static-safe work station. Ensure that the assembly is not placed on any conductive material.



8. Remove the A16 assembly and place it in a static-safe container.

A16 Processor/Video Board Assembly

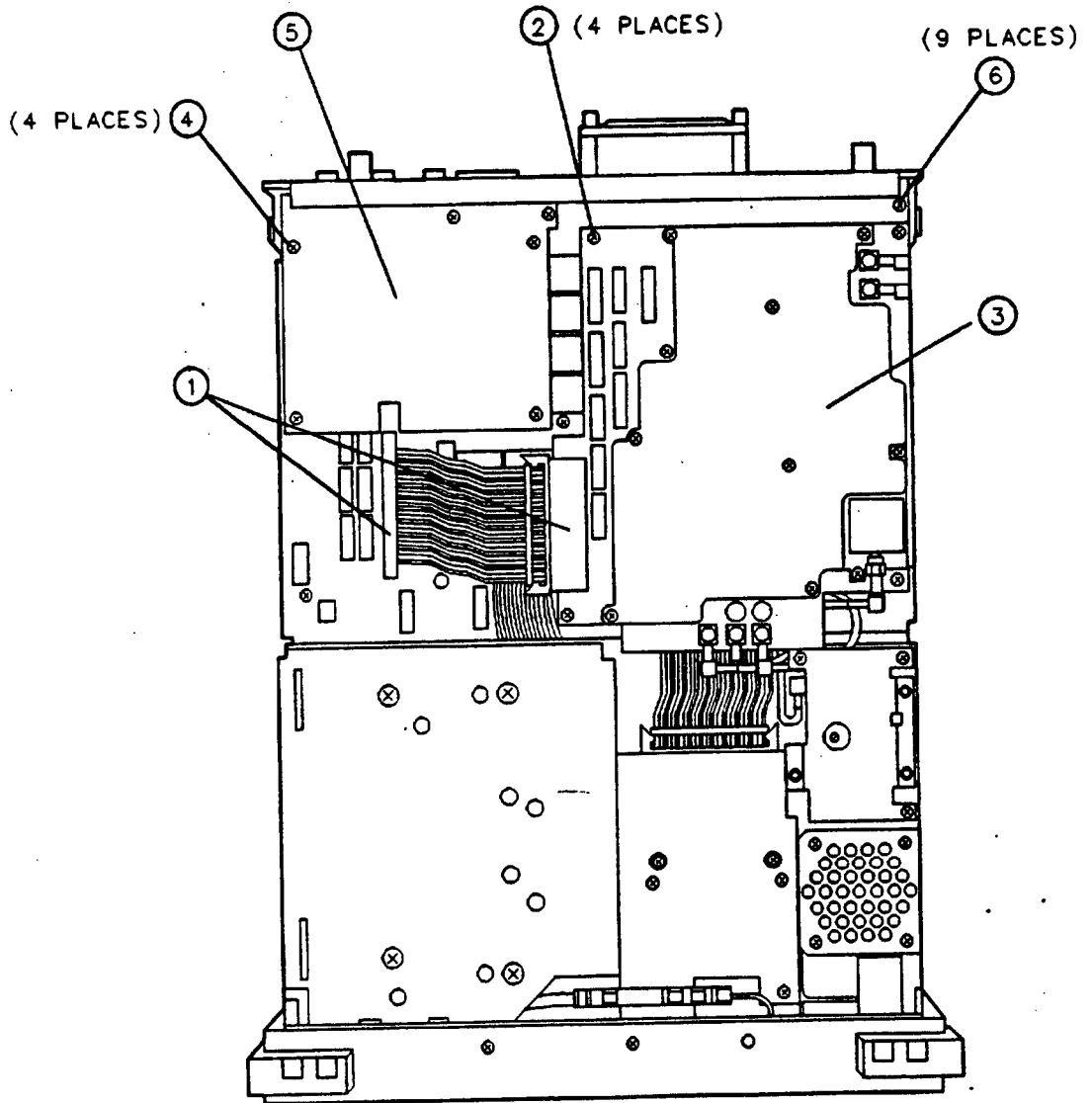

Figure 3-34. A16 Processor/Video Board Replacement

A16 Processor/Video Board Assembly

Replacement

Caution

To prevent damage to connectors A16J1 and A15J2, make sure that they are mated correctly before pushing the A16 assembly into place. Avoid twisting the A16 assembly from side to side during installation.

1. Replace the A16 Processor/Video Board Assembly.
 2. Replace the nine screws (6) that secure the A16 assembly. See Figure 3-34.
-

Note

For Option 021 or 023 only:

- Replace the A20 or A21 IO Board Assembly (5).
 - Replace the four screws (4) that secure the A20 or A21 IO Board Assembly.
-

3. Replace the A25 Counter-Lock Assembly (3).
 4. Replace the four screws (2) that secure the A25 assembly.
 5. Connect the W14 ribbon cable (1) to A16J2 and A25J4.
-

Caution

To prevent cable and wire damage, ensure all wiring is routed to one side of the SMB connector, A15J18, and through the notch located on the rear edge of the A15 motherboard.

6. Replace the rear-frame assembly.
7. Replace the instrument cover assembly. Refer to the "Instrument Cover" replacement procedure.

After Replacing the A16 Processor/Video Board Assembly

Note

If no valid correction constants were saved before removal of the A16 assembly, new correction constants must be generated.

- Perform the “Resetting the Analyzer Power-On Units” procedure in Chapter 9.
 - Perform the “10 MHz Reference (Standard),” “Frequency Response,” and “Cal Attenuator Error Correction” adjustment procedures in Chapter 2 to generate new correction constants.
 - Perform the “Instrument Recalibration after Reloading the Correction Constants” in Chapter 9.
-

If valid correction constants were saved before replacing the A16 assembly, restore the corrections to RAM memory and recalibrate the analyzer using the following procedures from “Analyzer Recovery after a A16 Memory Loss” in Chapter 9.

1. Use the “Resetting the Analyzer Power-On Units” procedure to reset the display units that appear when the analyzer is first powered on.
2. Use the “Reloading the Timebase and Flatness-Correction Constants” procedure to restore the timebase and flatness correction constants in RAM memory.
3. Use the “Reloading the A12 Step-Gain Correction Constants” procedure to restore the step gain correction constants in RAM memory.
4. Use the “Instrument Recalibration after Reloading the Correction Constants” procedure to recalibrate the analyzer and set it to the original default configuration settings.

A16 Processor/Video Board Firmware ROMs

Caution Use ESD precautions when performing this replacement procedure.



Removal

1. Remove the instrument cover assembly. Refer to the "Instrument Cover" removal procedure.
2. Disconnect the W14 ribbon cable from A25J4 (1). See Figure 3-34.
3. Remove the four screws (2) that secure the A25 Counter-Lock Assembly.
4. Remove the A25 assembly (3).
5. Note the location of the four firmware ROMs: A16U6, A16U7, A16U23, and A16U24. Refer to Figure 3-35.
6. Carefully pry the ROMs upward using a small-blade screwdriver. Pull the ROMs from their sockets evenly so that the IC pins (1) at the rear of each ROM are not bent.

Replacement

Caution



To prevent damage to the ROMs, make sure that the ROMs are oriented correctly with the sockets on the A16 assembly. Match the notch (2) at the end of each ROM with the notch at the end of its socket. Align each ROM IC pin with the opening of its pin receptacle on the socket.

1. Position each ROM on the A16 assembly as illustrated in Figure 3-35.
2. Install each ROM by carefully pushing down on both ends of the ROM with equal pressure.
3. Replace the A25 Counter-Lock assembly (3). See Figure 3-34.
4. Replace the four screws (2) that secure the counter-lock assembly.
5. Connect the W14 ribbon cable to A25J4 (1).
6. Replace the instrument cover assembly. Refer to the "Instrument Cover" replacement procedure.
7. Continue at the "Adjustments Required after ROM Replacement" procedure.

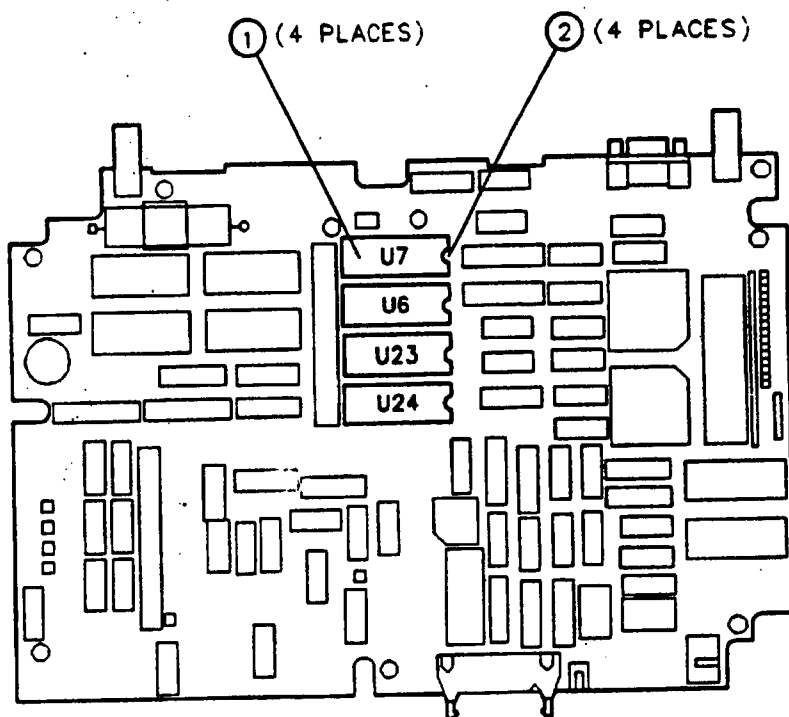

Figure 3-35. A16 Processor/Video Board Firmware ROM Replacement

Adjustments Required after ROM Replacement

1. Plug the power cable into the line module of the analyzer.
2. Plug the power cable into an ac power socket.
3. Press the **LINE** switch.
4. Press **PRESET**.
5. Let the analyzer warm up for 30 minutes.

Note



A **FREQ UNCAL** message may appear on screen but will disappear after the successful completion of the self-calibration routines.

6. Press the following analyzer keys:

CONFIG **MORE 1 of 3**

DISPOSE USER MEM DISPOSE USER MEM DEFAULT CONFIG DEFAULT CONFIG

7. Connect **CAL OUT** to the analyzer's input connector, using the appropriate cable and adapters.
8. Press **CAL**, **CAL AMPTD & FREQ**. Wait for the completion of the self-calibration routines.

A16 Processor/Video Board Firmware ROMs

Note



If the error message CAL SIGNAL NOT FOUND is displayed, verify that CAL OUT is properly connected to the analyzer input. If the connection is correct, set the user pass code by pressing **FREQUENCY**, **CENTER FREQ**, **-37 Hz**, then repeat step 8. (Enabling the pass code causes the self-calibration routine to skip the CAL OUT setup check.)

9. Connect 100 MHz COMB OUT to the analyzer's input, using the appropriate cable and adapters.
10. Press **CAL YTF**. Wait for the completion of the CAL YTF self-calibration routine.
11. Press **CAL STORE**.
12. Press **MORE 1 of 3**, **CRT HORIZ POSITION**.
13. Using the analyzer knob, adjust the display's horizontal position, if necessary.
14. Press **CRT VERT POSITION**.
15. Using the analyzer knob, adjust the display's vertical position, if necessary.
16. Press **MORE 2 of 3**, **MORE 3 of 3**, **CAL STORE**.

A17 Memory Card Reader Assembly

Removal

1. Remove the instrument cover assembly. Refer to the "Instrument Cover" removal procedure.
2. Place the analyzer on the work surface with the bottom side facing up.
3. Disconnect the W14 ribbon cable (1) from the A17 Memory Card Reader assembly. See Figure 3-36.
4. Remove the two screws (2) that secure the A17 assembly to the chassis.

Caution

When removing the A17 assembly, be sure to slide the assembly straight backward to prevent damage to the two alignment tabs on the front of the A17 support bracket.

5. Remove the A17 assembly (3), gently sliding the assembly towards the rear of the analyzer and up.
6. Remove the four screws (4) that secure the A17 assembly to the memory-card base and remove the A17 assembly.

Replacement

1. Place the analyzer on the work surface with the bottom side facing up.
2. Place the A17 Memory Card Reader assembly on the memory-card base.
3. Replace the four screws (4) that secure the A17 assembly to the memory-card base.

Caution

The two alignment tabs on the memory-card base beneath the A17 Memory Card Reader assembly can be easily damaged. When replacing the A17 Memory Card Reader assembly, carefully mate the two alignment tabs with the memory-card bezel on the front-frame assembly.

4. Replace the A17 assembly (3), gently sliding the assembly along the chassis toward the memory-card reader bezel on the front-frame assembly.
5. Replace the two screws (2) that secure the A17 assembly to the chassis.
6. Connect the W14 ribbon cable (1) to the A17 assembly.
7. Replace the instrument cover assembly. Refer to the "Instrument Cover" replacement procedure.

A17 Memory Card Reader Assembly

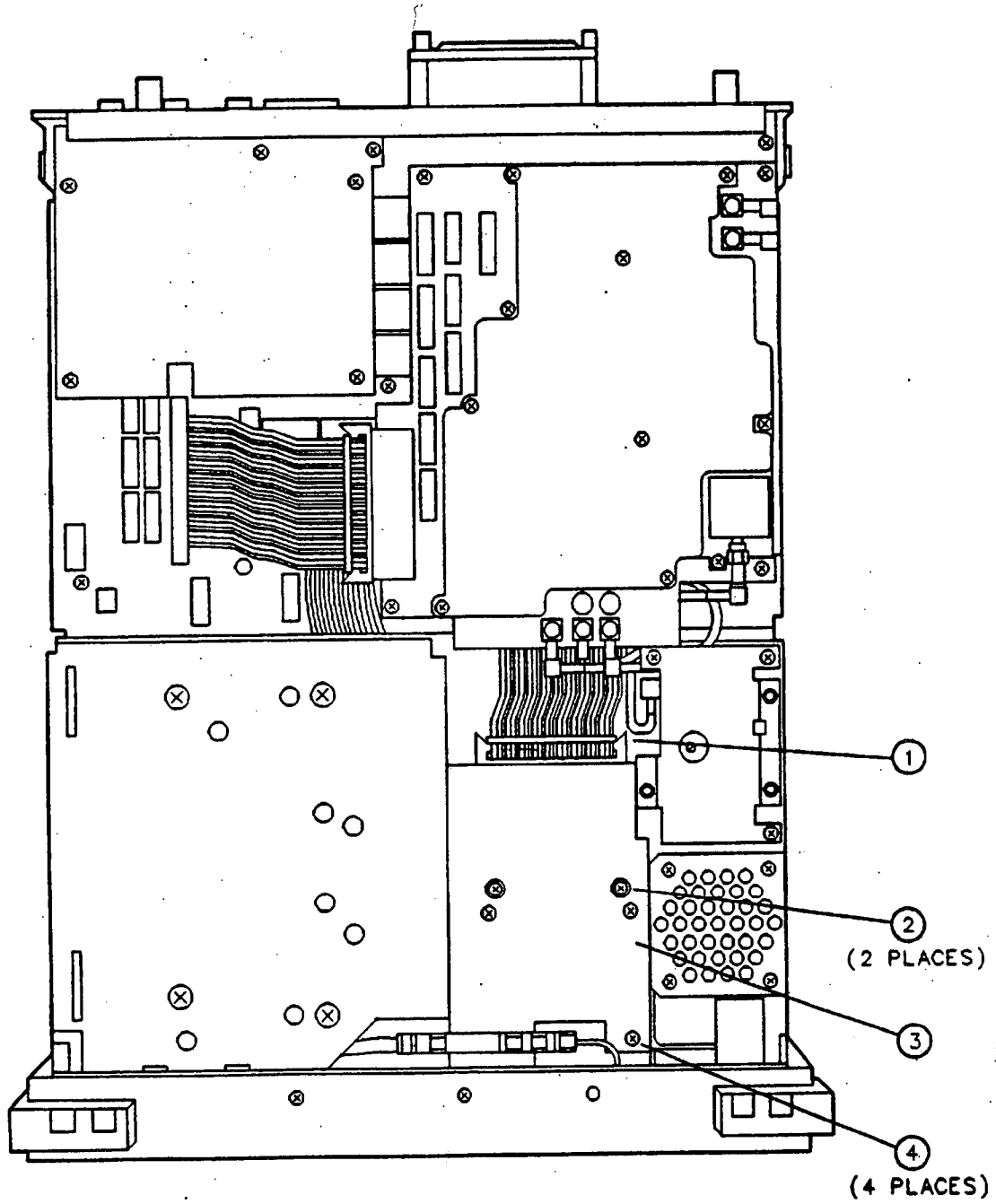

Figure 3-36. A17 Memory Card Reader Replacement

B1 Fan

Removal

1. Disconnect the analyzer from ac power.
2. Place the instrument on the work surface with the back end facing out.
3. Hold the B1 Fan assembly in position and loosen the four screws (1) that secure the fan assembly to the rear-frame assembly. See Figure 3-37.
4. Pull the fan 2 inches away from the instrument, reach into the opening in the rear frame, and disconnect the fan wiring from A15J19 (2).
5. Remove the four screws, washers, and spacers from the fan (1).
6. Remove the fan grill (3).

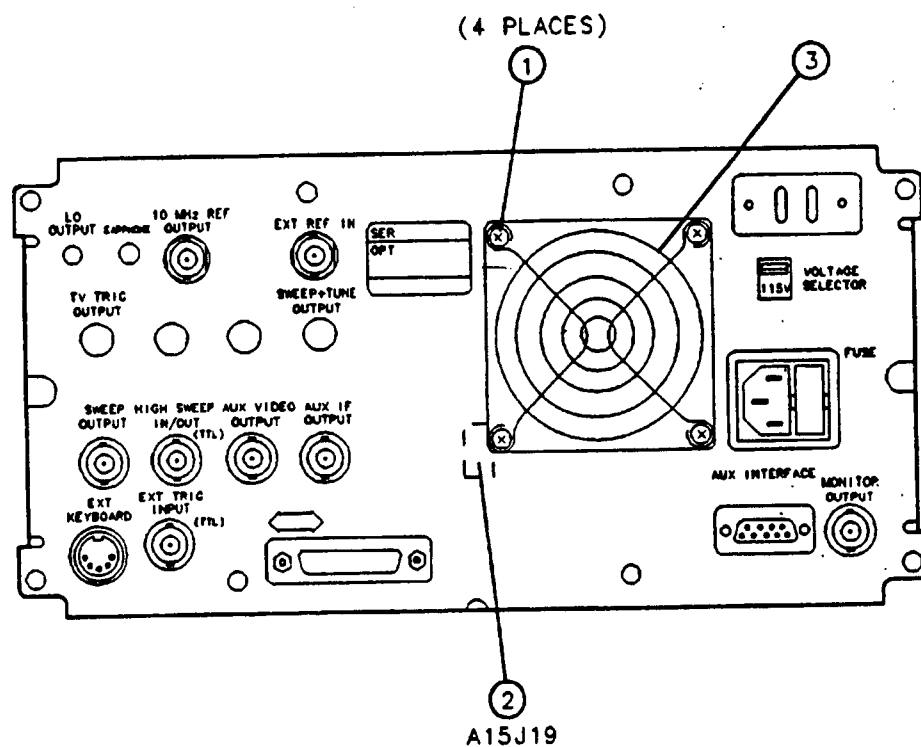

Figure 3-37. B1 Fan Replacement

B1 Fan

Replacement

Note

The direction of airflow through the instrument is important for proper cooling. The HP 8595A Portable Spectrum Analyzer fan pulls air from inside the instrument and exhausts it to the outside. This is a change in airflow from that of the HP 8590A and HP 8592A.

1. Position the fan grill on the B1 Fan (3). The fan label must be visible through the fan grill to make sure that the fan provides the correct airflow. See Figure 3-37.
2. Position the four spacers on the fan and replace the screws and washers (1).
3. Hold the fan 2 inches away from the instrument and connect the fan wiring to A15J19 (2).
4. Position the fan assembly on the instrument and tighten the four screws (1) that secure it to the rear frame.

BT101 Battery

Caution Use ESD precautions when performing this replacement procedure.



Warning Battery BT101 contains lithium iodide. Do not incinerate or puncture this battery. Dispose of the discharged battery in a safe manner.



Removal/Replacement

Caution The A16 Processor/Video Board assembly may be damaged if it is placed on a conductive surface. Use a static-safe work station. Ensure that the processor/video board assembly is not placed on any conductive material.



1. Remove the A16 Processor/Video Board assembly. Refer to the "A16 Processor/Video Board Assembly" removal procedure.
2. Remove the center pin (1) from the fastener (2) that secure the nylon insulator to the A16 assembly. See Figure 3-38.

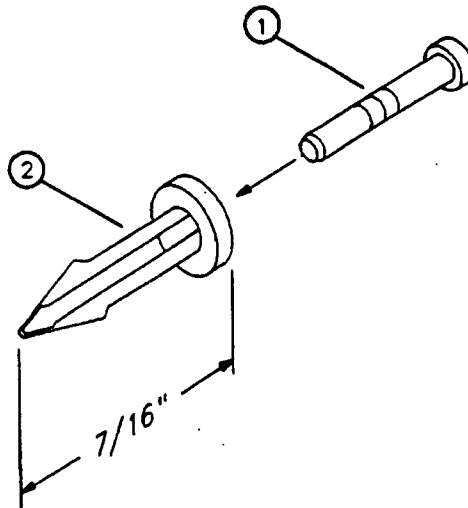

Figure 3-38. BT101 Battery Replacement

BT101 Battery

Caution



Placing the bottom side of the A16 assembly on a conductive work surface without the nylon insulator can result in loss of correction data stored in RAM. Protect the A16 assembly from contact with any conductive surface.

3. Remove the nylon insulator from the bottom of the A16 board assembly.
4. Locate the battery leads on the A16 assembly, desolder them, and remove the old battery.

Note



A16C106 maintains the voltage required to back up RAM for a maximum of 8 hours. A16C106 is the large capacitor next to A16C101.

5. Remove the insulating tubing from the positive (+) lead of the old battery and place it on the positive (+) lead of the new battery.

Note



If the battery is installed backwards, LED DS101 comes on. DS101 is located to the right of the battery on the A16 printed circuit board.

6. Replace and solder the leads on the new battery, ensuring proper polarity as silkscreened on the A16 board assembly.
7. Replace the nylon insulator on the bottom of the A16 board assembly. Insert the fastener (2) through the insulator and A16 board assembly. Then insert the center pin (1) to secure the nylon insulator.
8. Record the battery-replacement date on the battery label located on the analyzer rear frame.
9. Replace the A16 Processor/Video Board assembly. Refer to the "A16 Processor/Video Board Assembly" replacement procedure.

Rear-Frame Assembly

Caution Use ESD precautions when performing this replacement procedure.



Removal

1. Remove the instrument cover assembly. Refer to the "Instrument Cover" removal procedure.
2. Place the spectrum analyzer with the top side facing up.
3. Remove the six screws (three on each side) that secure the rear-frame to the main chassis.
4. Remove the W6 jumper from the 10 MHz REF OUTPUT and the EXT REF IN connectors.

Note



If the instrument came equipped with an LO Output on the rear panel (Option 009), do the following steps:

- a. Remove the 50 Ω load from the W42 coaxial cable.
- b. Remove the nut and washer that secure the W42 coaxial cable to the LO OUTPUT connector on the rear-frame.

-
5. Pull the rear-frame straight back away from the main chassis.
 6. Disconnect the fan assembly from J19 on the A15 IF Motherboard assembly.
 7. Disconnect W44, W45, and W46 from the A111 assembly.
 8. Disconnect W17 from the 10 MHz REF OUTPUT connector on the rear-frame assembly.

Replacement

1. Connect W17 to the 10 MHz REF OUTPUT connector on the rear-frame assembly.
2. Connect W44, W45, and W46 to the A111 assembly.
3. Connect the fan assembly to J19 on the A15 IF Motherboard assembly.

Caution



Wiring can be pinched between the rear frame and the edge of the A15 Motherboard. Make sure that all wiring is routed to one side of the SMB connector, A15J18, and through the notch located on the rear edge of the motherboard.

-
4. Place the rear-frame on the main chassis.

Rear-Frame Assembly

Note



If the instrument came equipped with an LO Output on the rear panel (Option 009), do the following steps:

- a. Insert the W42 coaxial cable through the rear-frame assembly and replace the nut and washer that secure the cable to the rear frame.
- b. Replace the 50 Ω load on the W42 coaxial cable.

-
5. Replace the W6 jumper between the 10 MHz REF OUTPUT and the EXT REF IN connectors.
 6. Replace the six screws (three on each side) that secure the rear-frame to the main chassis.
 7. Replace the instrument cover assembly. Refer to the "Instrument Cover" replacement procedure.

Replaceable Parts

Introduction

This chapter contains information for identifying and ordering replacement assemblies and mechanical parts for the HP 8595A Portable Spectrum Analyzer. Major assembly and cable location information is given in Chapter 5.

The following tables and figures are also included in this chapter:

- Table 4-1 lists reference designations, abbreviations, and value multipliers used in the parts lists.
- Table 4-2 lists all major assemblies, and all major mechanical and electrical parts that are not part of a major assembly.
- Table 4-3 lists the history of the firmware. This includes the revision dates, part numbers of the ROMs, serial number breaks, and major changes of the firmware.
- Figures 4-1 through 4-13 give the spectrum analyzer parts identification information.

Note



The parts lists, schematics, and component-location diagrams for the HP 8595A Portable Spectrum Analyzer's board assemblies are available separately in HP 8590 Series Component-Level Information Packets.

Assembly-Level Replaceable Parts Table Format

Table 4-2 lists the following information for each major assembly and for each major mechanical and electrical part that is not part of a major assembly:

1. Assembly reference designation.
2. Hewlett-Packard part number.
3. Part number check digit (CD).
4. Description of the assembly.

Parts Identification Format

Figures 4-1 through 4-13 contain illustrations of the spectrum analyzer with a listing of the chassis mechanical parts that are identified in each figure. The following information is listed for each part:

1. Item number of callout in figure.
2. Hewlett-Packard part number.
3. Part number check digit (CD).
4. Description of the part.

Ordering Information

To order an assembly or mechanical part listed in this chapter, quote the Hewlett-Packard part number and the check digit, and indicate the quantity required. The check digit is used to verify the correct part number. The check digit will ensure accurate processing of your order.

To order a part that is *not* listed, include the following information with the order:

- Spectrum analyzer model number.
- Spectrum analyzer serial number.
- Description of where the part is located, what it looks like, and its function (if known).
- Quantity needed.

Parts can be ordered by addressing the order to the nearest Hewlett-Packard office. Customers within the USA can also use either the direct mail-order system, or the direct phone-order system described below. The direct phone-order system has a toll-free phone number available.

Direct Mail-Order System

Within the USA, Hewlett-Packard can supply parts through a direct mail-order system. Advantages of using the system are as follows:

- Direct ordering and shipment from Hewlett-Packard.
- No maximum or minimum on any mail order. (There is a minimum order amount for parts ordered through a local HP office when the orders require billing and invoicing.)
- Prepaid transportation. (There is a small handling charge for each order.)
- No invoices.

To provide these advantages, a check or money order must accompany each order. Mail-order forms and specific ordering information are available through your local HP office.

Direct Phone-Order System

Within the USA, a phone order system is available for regular and hotline replacement parts service. A toll-free phone number is available, and Mastercard and Visa are accepted.

Regular Orders

The toll-free phone number, (800) 227-8164, is available Monday through Friday, 6 AM to 5 PM (Pacific time). Regular orders have a four-day delivery time.

Hotline Orders

Hotline service is available 24 hours a day, 365 days a year, for emergency parts ordering. The toll-free phone number, (800) 227-8164, is available Monday through Friday, 6 AM to 5 PM (Pacific time). After-hours and on holidays, call (415) 968-2347.

To cover the cost of freight and special handing, there is an additional hotline charge on each order (three line items maximum per order). Hotline orders are normally delivered the next business day after they are ordered.

Table 4-1. Reference Designations, Abbreviations and Multipliers (1 of 4)

REFERENCE DESIGNATIONS		
A	Assembly	F Fuse
AT	Attenuator, Isolator, Limiter, Termination	FL Filter
B	Fan, Motor	HY Circulator
BT	Battery	J Electrical Connector (Stationary Portion), Jack
C	Capacitor	K Relay
CP	Coupler	L Coil, Inductor
CR	Diode, Diode Thyristor, Step Recovery Diode, Varactor	M Meter
DC	Directional Coupler	MP Miscellaneous Mechanical Part
DL	Delay Line	P Electrical Connector (Movable Portion), Plug
DS	Annunciator, Lamp, Light Emitting Diode (LED), Signaling Device (Visible)	Q Silicon Controlled Rectifier (SCR), Transistor, Triode Thyristor
E	Miscellaneous Electrical Part	R Resistor
		RT Thermistor
		S Switch
		T Transformer
		TB Terminal Board
		TC Thermocouple
		TP Test Point
		U Integrated Circuit, Microcircuit
		V Electron Tube
		VR Breakdown Diode (Zener), Voltage Regulator
		W Cable, Wire, Jumper
		X Socket
		Y Crystal Unit (Piezoelectric, Quartz)
		Z Tuned Cavity, Tuned Circuit

ABBREVIATIONS		
A		BSC Basic
A	Across Flats, Acrylic, Air (Dry Method), Ampere	BTN Button
ADJ	Adjust, Adjustment	C
ANSI	American National Standards Institute (formerly USASI-ASA)	C Capacitance, Capacitor, Center Tapped, Cermet, Cold, Compression
ASSY	Assembly	CCP Carbon Composition Plastic
AWG	American Wire Gage	CD Cadmium, Card, Cord
B		CER Ceramic
BCD	Binary Coded Decimal	CHAM Chamfer
BD	Board, Bundle	CHAR Character, Characteristic, Charcoal
BE-CU	Beryllium Copper	CMOS Complementary Metal Oxide Semiconductor
BNC	Type of Connector	
BRG	Bearing, Boring	D
BRS	Brass	D Deep, Depletion, Depth, Diameter, Direct Current
		DA Darlington
		CNDCT Conducting, Conductive, Conductivity, Conductor
		CONT Contact, Continuous, Control, Controller
		CONV Converter
		CPRSN Compression
		CUP-PT Cup Point
		CW Clockwise, Continuous Wave

Table 4-1. Reference Designations, Abbreviations, and Multipliers (2 of 4)

ABBREVIATIONS					
DAP-GL	Diallyl Phthalate Glass	FT	Current Gain Bandwidth Product (Transition Frequency), Feet, Foot	JFET	Junction Field Effect Transistor
DBL	Double				K
DCDR	Decoder				
DEG	Degree				
D-HOLE	D-Shaped Hole	FXD	Fixed	K	Kelvin, Key, Kilo, Potassium
DIA	Diameter				
DIP	Dual In-Line Package		G	KNRLD	Knurled
DIP-SLDR	Dip Solder			KVDC	Kilovolts Direct Current
D-MODE	Depletion Mode	GEN	General, Generator		
DO	Package Type Designation	GND	Ground		L
DP	Deep, Depth, Dia- metric Pitch, Dip	GP	General Purpose, Group		
DP3T	Double Pole Three Throw		H	LED	Light Emitting Diode
DPDT	Double Pole Double Throw	H	Henry, High	LG	Length, Long
DWL	Dowell	HDW	Hardware	LIN	Linear, Linearity
		HEX	Hexadecimal, Hexagon, Hexagonal	LK	Link, Lock
	E			LKG	Leakage, Locking
E-R	E-Ring	HLCL	Helical--	LUM	Luminous
EXT	Extended, Extension, External, Extinguish	HP	Hewlett-Packard Company, High Pass		M
	F		I	M	Male, Maximum, Mega, Mil, Milli, Mode
F	Fahrenheit, Farad, Female, Film (Resistor), Fixed, Flange, Frequency	IC	Collector Current, Integrated Circuit	MA	Milliampere
		ID	Identification, Inside Diameter	MACH	Machined
FC	Carbon Film/ Composition, Edge of Cutoff Frequency, Face	IF	Forward Current, Intermediate Frequency	MAX	Maximum
		IN	Inch	MC	Molded Carbon Composition
FDTHRU	Feedthrough	INCL	Including	MET	Metal, Metallized
FEM	Female	INT	Integral, Intensity, Internal	MHZ	Megahertz
FIL-HD	Fillister Head			MINTR	Miniature
FL	Flash, Flat, Fluid		J	MIT	Miter
FLAT-PT	Flat Point			MLD	Mold, Molded
FR	Front		J-FET	MM	Magnetized Material, Millimeter
FREQ	Frequency		Junction Field Effect Transistor	MOM	Momentary
				MTG	Mounting
				MTLC	Metallic
				MW	Milliwatt

Table 4-1. Reference Designations, Abbreviations, and Multipliers (3 of 4)

ABBREVIATIONS					
N		PLSTC	Plastic	SMA	Subminiature, A Type (Threaded Connector)
N	Nano, None	PNL	Panel	SMB	Subminiature, B Type (Slip-on Connector)
N-CHAN	N-Channel	PNP	Positive Negative Positive (Transistor)	SMC	Subminiature, C-Type (Threaded Connector)
NH	Nanohenry	POLYC	Polycarbonate	SPCG	Spacing
NM	Nanometer, Nonmetallic	POLYE	Polyester	SPDT	Single Pole Double Throw
NO	Normally Open, Number	POT	Potentiometer	SPST	Single Pole Single Throw
NOM	Nominal	POZI	Pozidriv Recess	SQ	Square
NPN	Negative Positive Negative (Transistor)	PREC	Precision	SST	Stainless Steel
NS	Nanosecond, Non-Shorting, Nose	PRP	Purple, Purpose	STL	Steel
NUM	Numeric	PSTN	Piston	SUBMIN	Subminiature
NYL	Nylon (Polyamide)	PT	Part, Point, Pulse Time	SZ	Size
	O	PW	Pulse Width		
OA	Over-All		Q		
OD	Outside Diameter		Q		
OP AMP	Operational Amplifier		Q		
OPT	Optical, Option, Optional		R		
	P		R		T
PA	Picoampere, Power Amplifier	REF	Range, Red, Resistance, Resistor, Right, Ring	T	Teeth, Temperature, Thickness, Time, Timed, Tooth, Typical
PAN-HD	Pan Head	RES	Reference	TA	Ambient Temperature, Tantalum
PAR	Parallel, Parity	RF	Resistance, Resistor	TC	Temperature Coefficient
PB	Lead (Metal), Pushbutton	RGD	Radio Frequency	THD	Thread, Threaded
PC	Printed Circuit	RIGD	Rigid	THK	Thick
PCB	Printed Circuit Board	RND	Round	TO	Package Type Designation
P-CHAN	P-Channel	RR	Rivet, Riveted	TPG	Tapping
PD	Pad, Power Dissipation	RVT	Rear	TR-HD	Truss Head
PF	Picofarad, Power Factor		S	TRMR	Trimmer
PKG	Package	SAWR	Surface Acoustic Wave Resonator	TRN	Turn, Turns
		SEG	Segment	TRSN	Torsion
		SGL	Single		
		SI	Silicon, Square Inch		
		SL	Slide, Slow		
		SLT	Slot, Slotted		

Table 4-1. Reference Designations, Abbreviations, and Multipliers (4 of 4)

ABBREVIATIONS					
	U		VAR Variable		Y
			VDC Volts—Direct Current		YIG Yttrium-Iron-Garnet
UCD	Microcandela			W	
UF	Microfarad				
UH	Microhenry				
UL	Microliter,				
	Underwriters'	W	Watt, Wattage,		Z
	Laboratories, Inc.		White, Wide, Width		
UNHDND	Unhardened	W/SW	With Switch		ZNR Zener
		WW	Wire Wound		
	V			X	
V	Variable, Violet,				
	Volt, Voltage	X	By (Used with		
VAC	Vacuum, Volts—		Dimensions),		
	Alternating Current		Reactance		

MULTIPLIERS					
Abbreviation	Prefix	Multiple	Abbreviation	Prefix	Multiple
T	tera	10 ¹²	m	milli	10 ⁻³
G	giga	10 ⁹	μ	micro	10 ⁻⁶
M	mega	10 ⁶	n	nano	10 ⁻⁹
k	kilo	10 ³	p	pico	10 ⁻¹²
da	deka	10	f	femto	10 ⁻¹⁵
d	deci	10 ⁻¹	a	atto	10 ⁻¹⁸
c	centi	10 ⁻²			

Table 4-2. HP 8595A Assembly-Level Replaceable Parts

Reference Designator	HP Part Number	CD	Description
A1	08595-60004	0	FRONT FRAME ASSEMBLY
	08595-60009	5	FRONT FRAME ASSEMBLY (OPTION 103)
A1A1	*		BOARD ASSEMBLY, KEYBOARD
A1A2	0960-0745	6	ROTARY PULSE GENERATOR
A1R1	08590-60133	1	VOLUME-INTENSITY DUAL-POT ASSEMBLY
A2	5062-6404	7	CRT DISPLAY ASSEMBLY (CABLES AND SHIELD NOT INCLUDED)
A3			FRONT-END ASSEMBLY
A3A1	*		COMB GENERATOR ASSEMBLY
A3A1A1	08569-60026	4	BOARD ASSEMBLY, COMB GENERATOR
A3A2	5086-7803	2	SWITCHED YIG TUNED FILTER (YTF) 6.5 GHZ
A3A3	0955-0420	3	FILTER LOW PASS 2.9 GHZ SMA
A3A4	5086-7819	0	SECOND CONVERTER ASSEMBLY
A3A5	5086-7777	8	ATTENUATOR, 0-70 DB/DC BLOCK
A3A6	5086-7826	9	DUAL BAND MIXER
A3A7	5086-7833	8	YIG TUNED OSCILLATOR (YTO) 3.0-6.82 GHZ
A3A8			NOT ASSIGNED
A3A9	9135-0252	0	BANDPASS FILTER 321.3 MHZ
A3A10	0955-0098	1	DIRECTIONAL COUPLER
A3A11	0955-0149	3	MODULE-DIODE RECOVERY DRIVE FREQ=100 MHZ
A3A12	0955-0412	3	3 DB MICROWAVE ATTENUATOR
A3A13	0955-0204	1	MICROWAVE ISOLATOR 6.6 GHZ MAX
A3A14	5086-7744	0	FIRST LO DISTRIBUTION AMPLIFIER ASSEMBLY (OPTION 009, 010)
A3A15	5086-7840	7	TRACKING GENERATOR ASSEMBLY (OPTION 010)
A7	*		BOARD ASSEMBLY, ANALOG INTERFACE
A8	0950-1977	7	POWER SUPPLY 100W
A9	*		BOARD ASSEMBLY, THIRD CONVERTER
	*		BOARD ASSEMBLY, THIRD CONVERTER (OPTION 010)
A10	*		BOARD ASSEMBLY, TRACKING GENERATOR CONTROL (OPTION 010)
	*		BOARD ASSEMBLY, LODA CONTROL (OPTION 009)
A11	*		BOARD ASSEMBLY, BANDWIDTH FILTER #1
A12	*		BOARD ASSEMBLY, AMPLITUDE CONTROL
A13	*		BOARD ASSEMBLY, BANDWIDTH FILTER #2
A14	*		BOARD ASSEMBLY, LOG AMP
A15	*		BOARD ASSEMBLY, MOTHERBOARD
A16	*		BOARD ASSEMBLY, PROCESSOR/VIDEO
A17	*		BOARD ASSEMBLY, MEMORY CARD (OPTION 003)
A18			NOT ASSIGNED

* Refer to Table A-1 for current HP part number.

Table 4-2. HP 8595A Assembly-Level Replaceable Parts

Reference Designator	HP Part Number	CD	Description
A19			NOT ASSIGNED
A20	*		BOARD ASSEMBLY, HP-IB I-O (OPTION 021)
A21	*		BOARD ASSEMBLY, RS-232 I-O (OPTION 023)
A22	1813-0644	4	10 MHZ, OVEN CONTROLLED CRYSTAL OSCILLATOR (OCXO) (OPTION 004)
A23			NOT ASSIGNED
A24			NOT ASSIGNED
A25	*		BOARD ASSEMBLY, COUNTER-LOCK
A101	*		BOARD ASSEMBLY, FAST TIME DOMAIN SWEEP (OPTION 101), BLACK AND BROWN EXTRACTORS
A102	*		BOARD ASSEMBLY, AM/FM SPEAKER/TV SYNC TRIGGER (OPTION 102), BLACK AND RED EXTRACTORS
A103	*		BOARD ASSEMBLY, QUASI PEAK DETECTOR (OPTION 103), BLACK AND ORANGE EXTRACTORS
A105	*		BOARD ASSEMBLY, TIME GATE (OPTION 105) BLACK AND GREEN EXTRACTORS
AT1	0955-0122	2	ATTENUATOR, 10 DB
AT2	1250-2289	9	50Ω TERMINATION (OPTION 009, 010)
B1	08590-60166	0	FAN ASSEMBLY
BT101	1420-0331	3	BATTERY, 3.6 V, 1.7 AMP HOURS
F1	2110-0709	3	FUSE 5.0A 250V F
FL1	0955-0405	4	3.9 GHZ LOW PASS FILTER
J1	1250-2180	3	CONNECTOR, RF INPUT (INPUT 50Ω), TYPE N (F)
J2	1250-1753	4	CONNECTOR, COMB GEN. OUTPUT, SMA (F)
J3	1250-2180	3	CONNECTOR, RF OUTPUT, TYPE N (F) (OPTION 010)
LS1	08590-60134	2	CABLE/SPEAKER ASSY
W1	5062-4809	2	CABLE ASSY WITH LINE SWITCH, A1 TO A16J9
W2	08590-60159	1	CABLE ASSY, DISPLAY VIDEO, A2 TO A16J8
W3	08590-60037	4	CABLE ASSY, INTENSITY, WITHOUT POTENTIOMETER, A1R1 TO A2
W4	08592-60037	6	CABLE ASSY, KEYBOARD, A1A1J1 TO A16J10
W5	5062-4826	3	CABLE ASSY, PROBE POWER, WITHOUT CONNECTOR, A1A1 TO A1
W6	1250-1499	5	JUMPER, 10 MHZ REF OUTPUT TO EXT REF IN
W7	8120-5052	6	CABLE ASSY, CAL OUTPUT, A9J2 TO A1
W8	8120-5020	8	CABLE ASSY, 600 MHZ DRVR, A9J5 TO A3A4J4
W9	8120-5106	1	CABLE ASSY, 2ND IF, A3A9J2 TO A9J4
W10	08592-20056	5	CABLE ASSY, RF INPUT, J1 TO A3A5J1
W11	08595-20002	3	CABLE ASSY, ATTENUATOR OUTPUT TO SWITCHED YTF, A3A5J2 TO A3A2J1

* Refer to Table A-1 for current HP part number.

Table 4-2. HP 8595A Assembly-Level Replaceable Parts

Reference Designator	HP Part Number	CD	Description
W12	08592-60019	4	CABLE ASSY, YTO DRIVER, A7J3 TO A3A7J1
W13	5062-7787		CABLE ASSY, POWER CONTROL, A7J2 TO A3A1/A3A2/A3A6
W14	08591-60008	2	CABLE ASSY, COUNTER LOCK/MEMORY CARD CONTROL, A16J2 TO A17J1/A25J4
W15	5062-6468	3	CABLE ASSY, PRECISION FREQUENCY REFERENCE POWER, A25J3 TO A22 (OPTION 004)
W16	08591-60013	7	CABLE ASSY, 10 MHZ OUTPUT, A25J7 TO REAR PANEL
W17	8120-5056	1	CABLE ASSY, 10 MHZ OUTPUT, A22J1 TO REAR PANEL (OPTION 004)
W18	08591-60009	3	CABLE ASSY, EXT REF IN, REAR PANEL TO A25J2
W19	08591-60012	6	CABLE ASSY, COUNT IF, A25J5 TO A15J18
W20	8120-5068	5	CABLE ASSY, SAMPLER FIRST LO, A3A10 TO AT1
W21	08591-60010	4	CABLE ASSY, SAMPLER FIRST LO, A3A14J4 TO AT1
W22	8120-5067	3	CABLE ASSY, 300 MHZ COUNT LOCK DRIVE, A9J3 TO A25J1
W23	8120-5058	2	CABLE ASSY, FIRST MIXER HI BAND, A3A6J5 TO A3A4J3
W24	08592-60058	1	CABLE ASSY, 2ND CONV. 321.4 MHZ OUT, A3A4J2 TO A3A9J1
W25			CABLE ASSY, COMB GEN. OUT, A3A1J1 TO A3A11
W26	08595-20003	5	NOT ASSIGNED
W27	08592-20048	5	SWITCHED YTF OUT, A3A2J3 TO A3A3J1
W28	1250-1788	5	CABLE ASSY, 2.9 GHZ LPF OUT, A3A3J2 TO A3A6J1
W29	08592-20046	3	CABLE ASSY, SWITCHED YTF OUT, A3A2J2 TO A3A6J3
	08593-20006	3	CABLE ASSY, FIRST MIXER LOW BAND, A3A6J2 TO FL1J1
		3	CABLE ASSY, FIRST MIXER LOW BAND, A3A6J2 TO FL1J1 (OPTION 010)
W30	08592-20049	6	CABLE ASSY, LPF OUTPUT, FL1J2 TO A3A4J1
	08593-20005	6	CABLE ASSY, LPF OUTPUT, FL1J2 TO A3A4J1 (OPTION 010)
W31	08592-20053	2	CABLE ASSY, YTO OUTPUT, A3A7J2 TO A3A13J1
	08593-20004	4	CABLE ASSY, YTO OUTPUT, A3A7J2 TO A3A14J1 (OPTION 009, 010)
W32	08592-20052	1	CABLE ASSY, ISOLATOR, A3A13J2 TO A3A10
W33	08592-20065	6	CABLE ASSY, DIR. CPLR. OUTPUT, A3A10 TO A3A6J4
	08593-20003	3	CABLE ASSY, 3.0 TO 6.8214 GHz OUTPUT, A3A14J2 TO A3A6J4 (OPTION 009, 010)
W34	08592-60018	3	CABLE ASSY, YTF DRIVER, A7J301 TO A3A2
W35	5062-6434	3	CABLE ASSY, 2ND CONV DRIVER, A7J4 TO A3A4J5
W36	5062-4813	8	CABLE ASSY, ATTENUATOR DRIVER, A7J5 TO A3A5

Table 4-2. HP 8595A Assembly-Level Replaceable Parts

Reference Designator	HP Part Number	CD	Description
W37	08592-20061	2	CABLE ASSY, COMB GEN. OUTPUT, A3A12 TO J2
W38	08593-60009	9	CABLE ASSY, LODA DRIVE, A10J2 TO A3A14 (OPTION 010)
W39	5062-7715	5	CABLE ASSY, TRACKING GENERATOR CONTROL, A10J1 TO A3A15J1 (OPTION 010)
W40	08593-60015	8	CABLE ASSY, 600 MHz TRACKING GENERATOR DRIVE, A3A15J8 TO A9J7 (OPTION 010)
W41	08593-20002	2	CABLE ASSY, FIRST LO, A3A14J3 TO A3A15J4 (OPTION 010)
W42	5062-7710	0	CABLE ASSY, FIRST LO OUTPUT, A3A15J3 TO REAR PANEL (OPTION 009, 010)
W43	08593-20007	7	CABLE ASSY, RF OUT, J3 TO A3A15J2 (OPTION 010)
W44-W46			NOT ASSIGNED
W47	08560-60001	6	CABLE ASSY, EXT ALC INPUT, REAR PANEL TO A3A15J6 (OPTION 010)
W48	8120-5401		CABLE ASSY, SWEEP + TUNE OUTPUT, A7J8 TO REAR PANEL (OPTION 009)
W49-W100			NOT ASSIGNED
W101	08591-60024	9	CABLE ASSY, TV TRIGGER OUTPUT, A102J2 TO REAR PANEL (OPTION 102)
W102	08590-60136	4	CABLE ASSY, VOLUME CONTROL, A1R1 TO A102 (OPTION 102)
W103			NOT ASSIGNED
W104	08590-60135	3	CABLE ASSY, HEADPHONE, A102 TO REAR PANEL (OPTION 102, 103)

Table 4-3 lists the history of the HP 8595A Portable Spectrum Analyzer firmware. Determine the version of firmware that is installed in the spectrum analyzer by cycling the instrument power and looking at the date displayed in the active function block.

Table 4-3. Firmware History

Revision Date (ddmmyy)	ROM Part Number U6, U7, U23, U24	Serial Prefix Break
17.12.90	08592-80083 08592-80084 08592-80085 08592-80086	First Serial Prefix 3051A

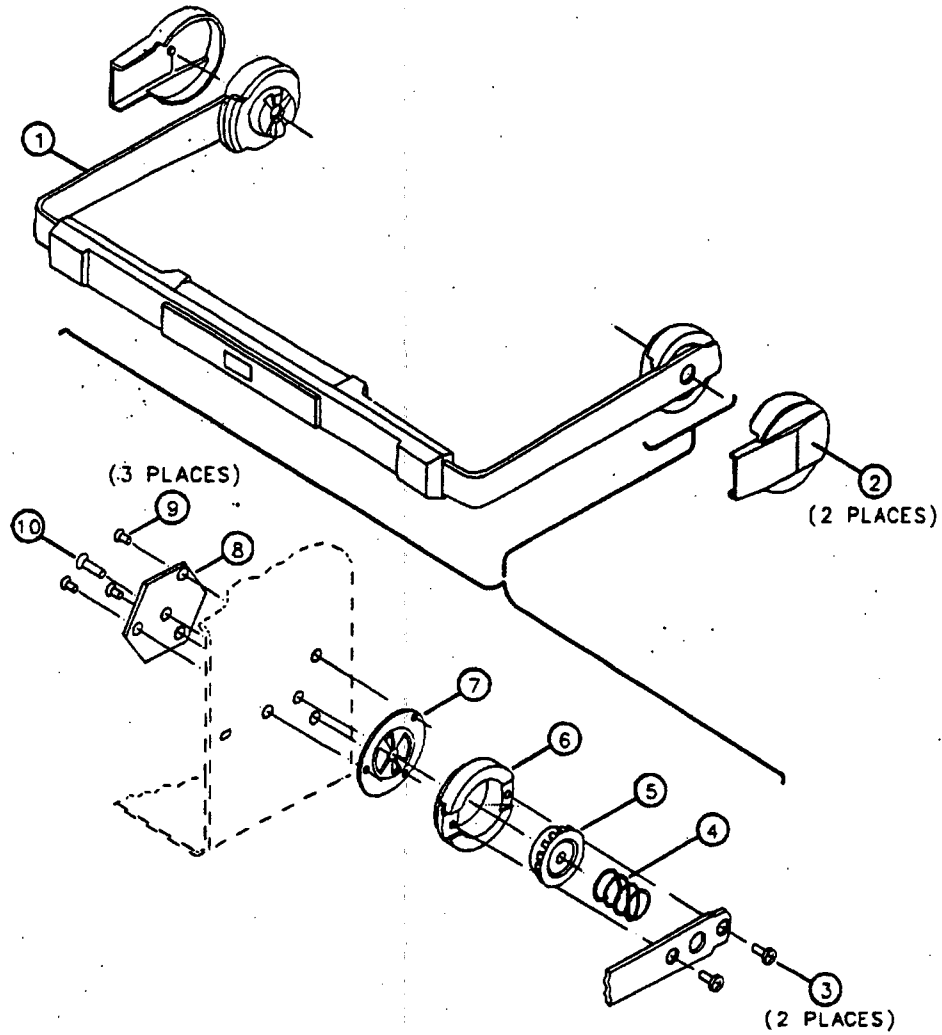

Item	HP Part Number	CD	Description
1	5041-8911	1	HANDLE
2	5041-8912	2	TRIM CAP
3	0515-1114	2	SCREW-MACH M4×0.7 10MM-LG PAN-HD
4	1460-2164	8	SPRING-CPR
5	5021-6343	7	RING GEAR
6	5021-6344	8	SOCKET GEAR
7	5021-8667	2	HANDLE PLATE
8	5001-8728	4	BACKUP PLATE
9	0515-1367	0	SCREW-MACH M4×0.7 8MM-LG FLH-HD
10	0515-1133	5	SCREW-MACH M5×0.8 16MM-LG

Figure 4-1. Spectrum Analyzer Parts Identification, Handle Assembly

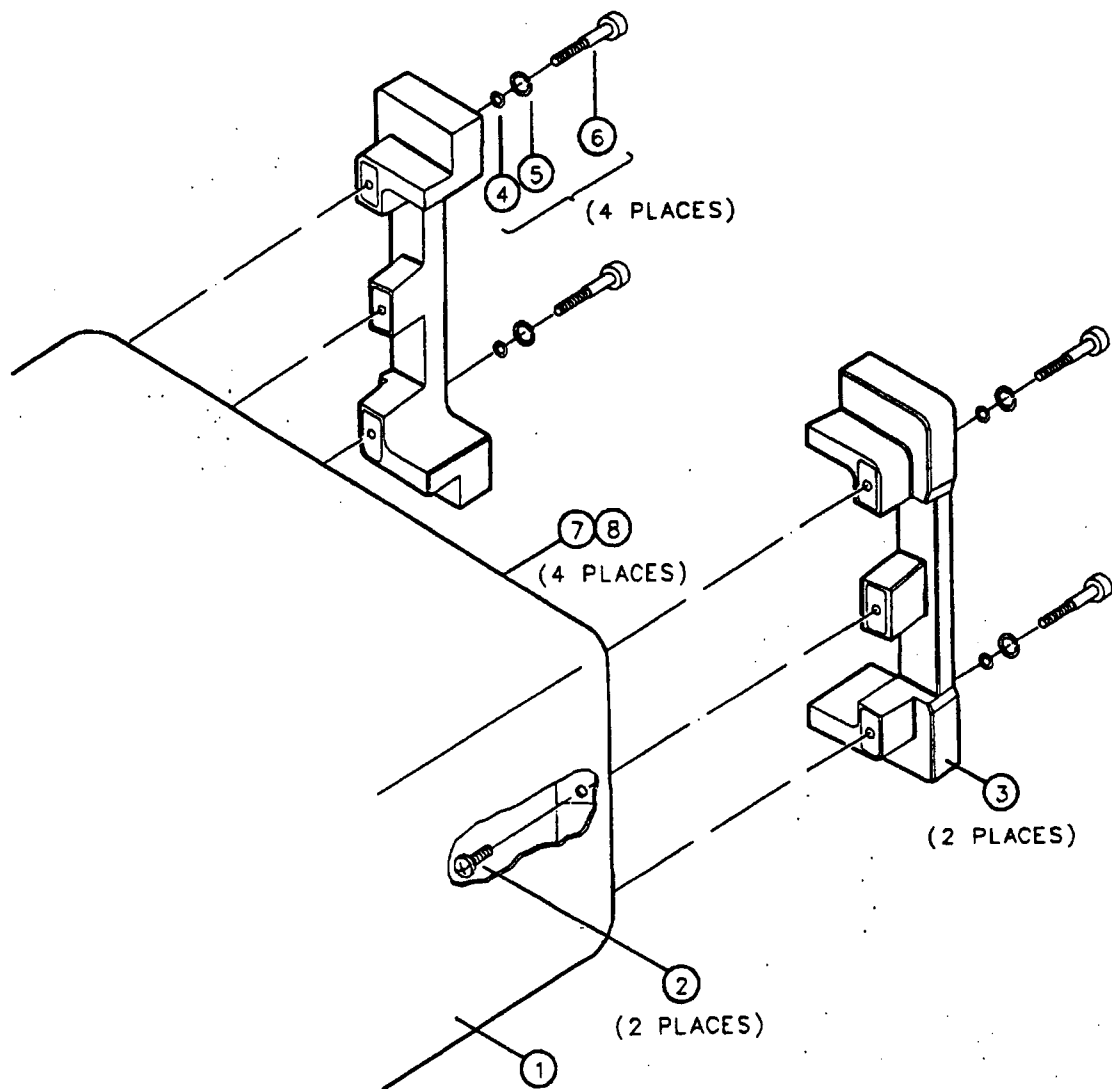

Item	HP Part Number	CD	Description
1	5001-8785	3	COVER
2	0515-1114	2	SCREW-MACH M4×0.7 10MM-LG PAN-HD
3	5041-8907	5	REAR FOOT
4	0900-0024	8	O-RING .145-IN-ID .07-IN-XSECT-DIA SIL
5	2190-0587	3	WASHER-LK HLCL 5.0 MM 5.1-MM-ID
6	0515-1218	7	SCREW-SKT-HD-CAP M5.0×0.8 40 MM-LG
7	3050-0893	9	WASHER-FLAT
8	0515-1069	6	SCREW M4.0×10MM PAN-HD

Figure 4-2. Spectrum Analyzer Parts Identification, Cover Assembly

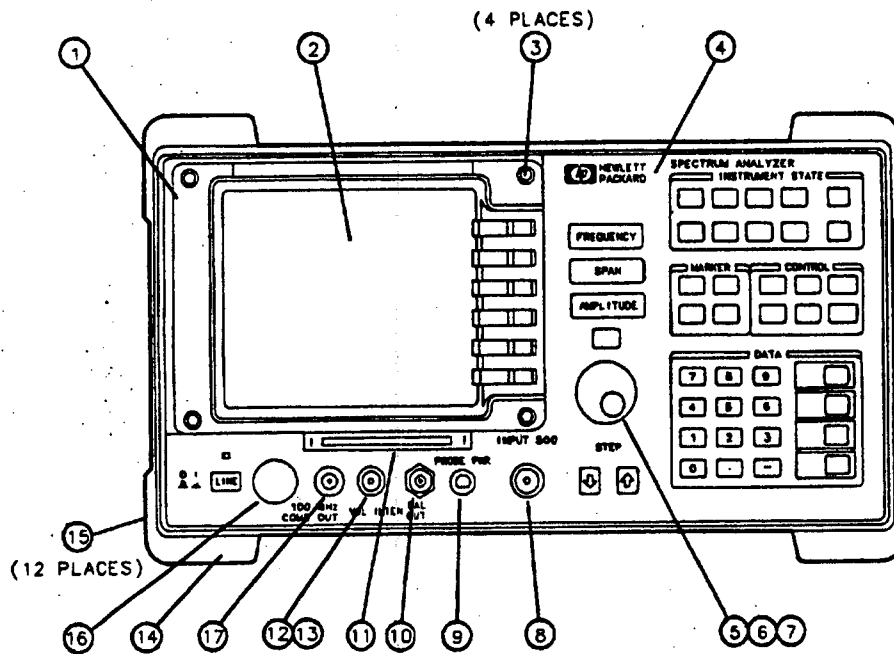

Item	HP Part Number	CD	Description
1	5041-8914	4	DISPLAY BEZEL ASSEMBLY
2	1000-0846	5	DISPLAY FILTER
3	0515-1622	7	SCREW-SKT-HD-CAP M4x0.7 8 MM-LG
4	08595-00001	9	HP8593A FRONT PANEL-DRESS
5	0370-3069	2	RPG TUNING KNOB
6	2950-0043	8	NUT-HEX-3/8x32
7	2190-0016	3	WASHER-LK INTL T 3/8 IN .377-IN-ID
8	1250-2180	3	ADAPTER,(F) SMA TO (F) TYPE N (INPUT 50Ω)
9	5060-0467	6	PROBE POWER CONNECTOR (M)
10	0590-1251	6	NUT-SPCLY 15/32-32-THD (SECURES W7)
11	5041-8917	7	MEMORY CARD BEZEL
12	5041-8924	6	VOLUME KNOB
13	5041-8925	7	INTENSITY KNOB
14	5062-4806	9	BUMPER KIT (SET OF 4)
15	0515-1079	8	SCREW-MACH M3.0 8MM-LG PAN-HD
16	6960-0148	8	PLUG (NOT ON OPTION 010)
17	1250-1753	4	ADAPTER SMA F TO SMA F

Figure 4-3. Spectrum Analyzer Parts Identification, Front Frame Assy

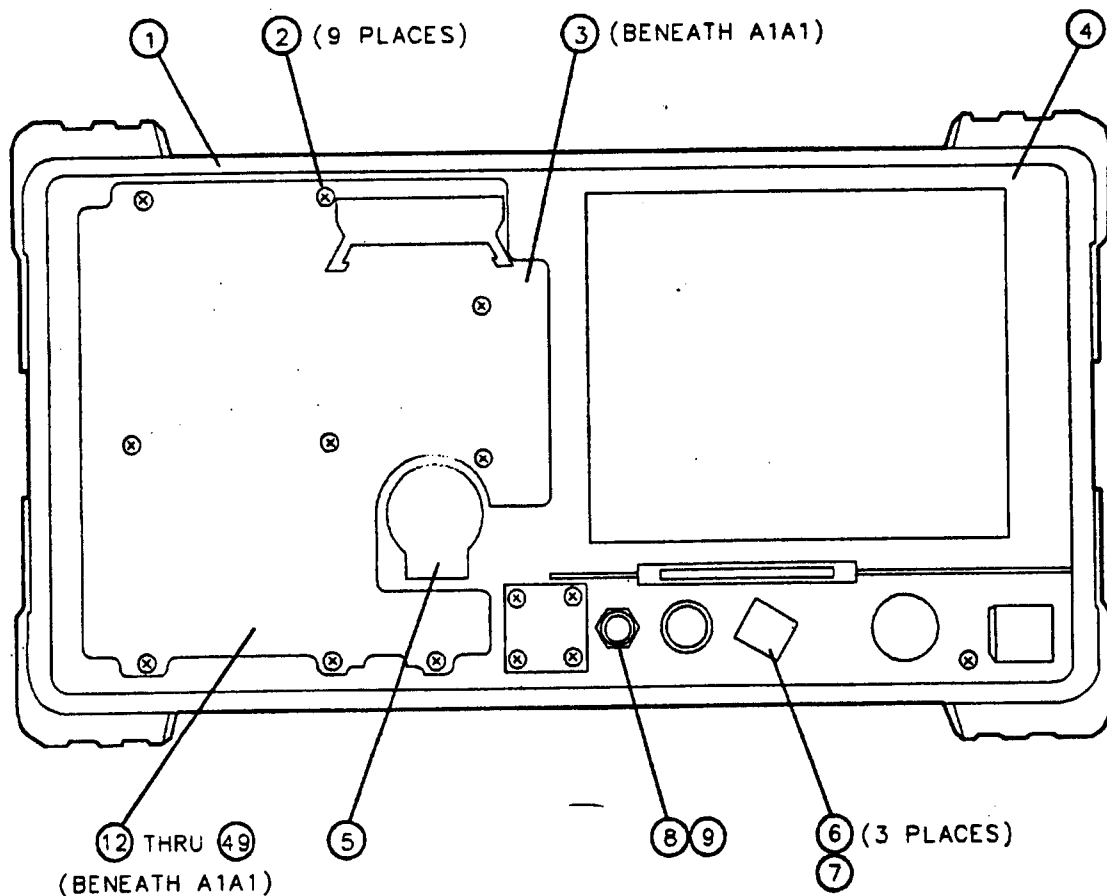

Item	HP Part Number	CD	Description
1	8160-0520	7	GASKET-EMI, 3 FT.
2	0515-1717	1	SCREW M2.5x6MM PAN-HD
3	5041-3938	2	RUBBER KEYPAD
4	5021-8666	1	FRONT FRAME CASTING
5	0960-0745	6	ROTARY PULSE GENERATOR
6	3050-0103	4	WASHER-FLAT .250ID12
7	08590-60133	1	VOLUME-INTENSITY DUAL-POT ASSEMBLY
8	2190-0016	3	LOCK WASHER .377ID
9	2950-0043	8	HEX NUT 3/8-32

Figure 4-4. Spectrum Analyzer Parts Identification, Front Frame Assy (1 of 2)

Item	HP Part Number	CD	Description
12	0535-0082	3	NUT WITH LOCK WASHER M4 (RETAINER FOR FRONT PANEL-DRESS)
13	5041-3939	3	KEY, "0"
14	5041-3940	6	KEY, "."
15	5041-3941	7	KEY, "1"
16	5041-3942	8	KEY, "2"
17	5041-3943	9	KEY, "3"
18	5041-3944	0	KEY, "4"
19	5041-3945	1	KEY, "5"
20	5041-3946	2	KEY, "7"
21	5041-3947	3	KEY, "8"
22	5041-3948	4	KEY, "BK SP"
23	5041-3949	5	KEY, "PK SEARCH"
24	5041-3950	8	KEY, "MKR ▶"
25	5041-3951	9	KEY, "HOLD"
26	5041-3954	2	KEY, "9"
27	5041-3955	3	KEY, "STEP"
28	5041-3956	4	KEY, "TERM"
29	5041-3957	5	KEY, "PRESET"
30	5041-3960	0	KEY, "FREQUENCY"
31	5041-3961	1	KEY, "SPAN"
32	5041-3962	2	KEY, "AMPLITUDE"
33	5041-3964	4	KEY, "SAVE"
34	5041-3965	5	KEY, "RECALL"
35	5041-3967	7	KEY, "AUTO COUPLE"
36	5041-3972	4	KEY, "BW"
37	5041-3973	5	KEY, "TRACE"
38	5041-3974	6	KEY, "DISPLAY"
39	5041-3976	8	KEY, "TRIG"
40	5041-3977	9	KEY, "SWEEP"
41	5041-7253	2	KEY, "CAL"
42	5041-7254	3	KEY, "CONFIG"
43	5041-7256	5	KEY, "MKR"
44	5041-7257	6	KEY, "SIG TRK"
45	5041-8919	9	KEY, "SGL SWP"
46	5041-8920	2	KEY, "AUX CTRL"
47	5041-8921	3	KEY, "COPY"
48	5041-8922	4	KEY, "MODE"
49	5041-8923	5	KEY, "MEAS/USER"

Figure 4-4. Spectrum Analyzer Parts Identification, Front Frame Assy. (2 of 2)

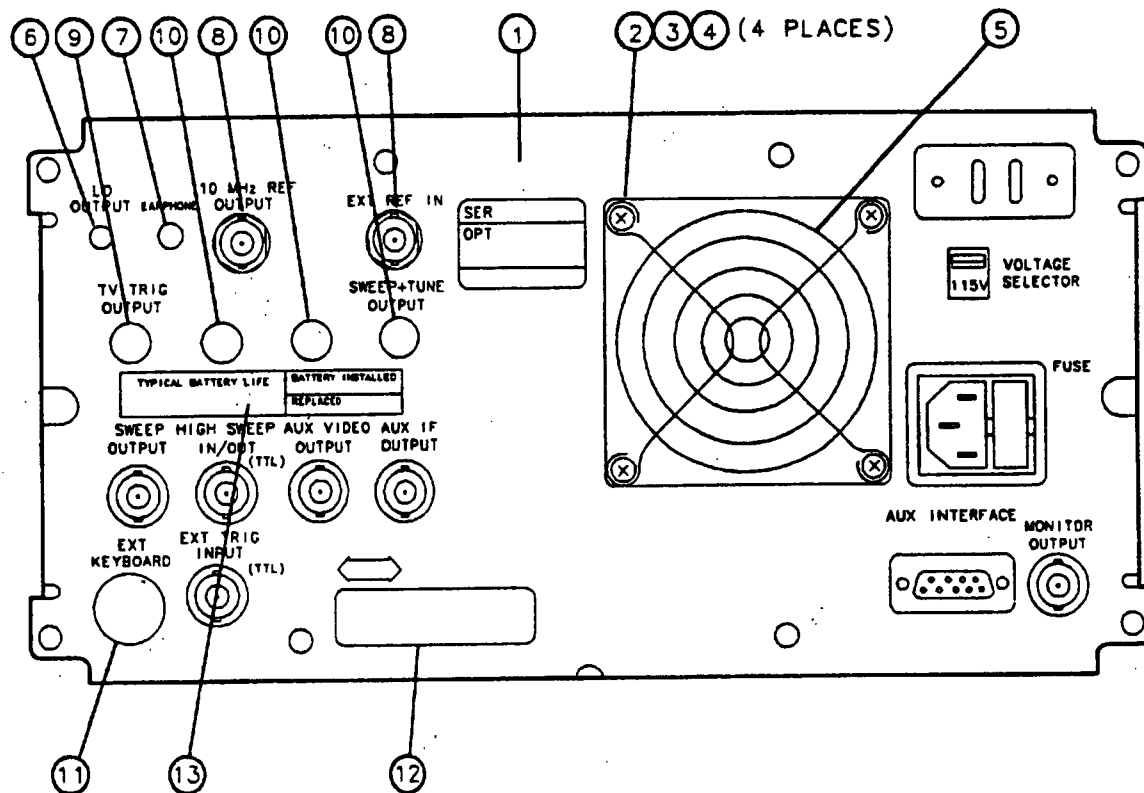

Item	HP Part Number	CD	Description
1	5001-8780	8	REAR FRAME
2	0380-1900	7	SPACER-ROUND .688L.166ID
3	3050-0105	6	WASHER-FLAT .125ID
4	0515-1465	6	SCREW-MACHINE M3.0 SEMPNPD
5	3160-0309	5	FAN GRILL
6	6960-0076	2	HOLE PLUG .312D (NOT ON OPTION 009)
7	6960-0076	2	HOLE PLUG .312D
	1252-0995	8	MINI-JACK CONNECTOR AND NUT (OPTION 102)
8	0590-1251	6	HEX NUT 15/32-32
9	6960-0150	3	HOLE PLUG 12.7DMM
	0590-1251	6	HEX NUT 15/32-32
10	6960-0150	3	HOLE PLUG 12.7DMM
11	6960-0082	0	HOLE PLUG .922D (NOT ON OPTION 021 OR 023)
12	08590-80012	7	HOLE COVER (NOT ON OPTION 021 OR 023)
13	9320-6058	9	BATTERY LABEL

Figure 4-5. Spectrum Analyzer Parts Identification, Rear Frame Assembly

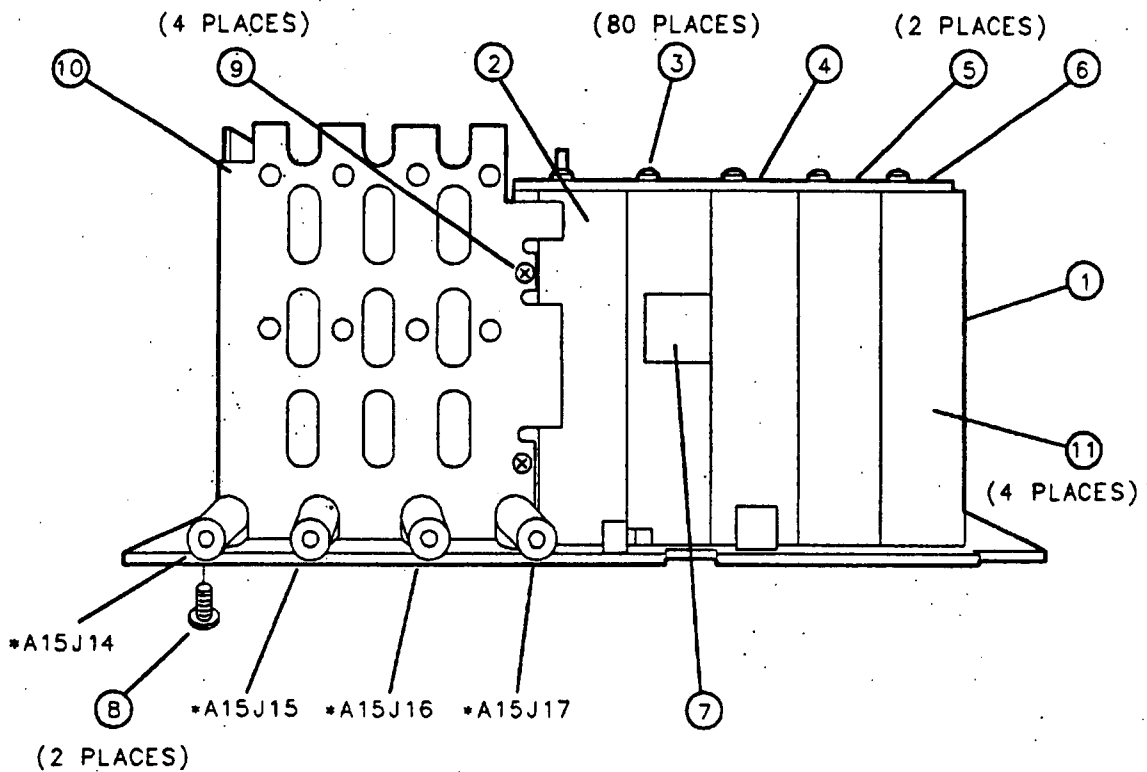

• REFER TO A15 COMPONENT LEVEL INFORMATION

Item	HP Part Number	CD	Description
1	5021-9907	4	EXTRUSION, END PLATE ENCLOSURE
2	5021-9908	5	EXTRUSION, CIRCUIT ENCLOSURE, TAPPED
3	0515-0866	2	SCREW-MACH M3.0 X 8MM
4	5001-8782	0	COVER-AMPLITUDE CONTROL
5	5001-8783	1	COVER-BANDWIDTH FILTER
6	5001-8769	3	COVER-LOG AMPLIFIER
7	1400-0510	8	CABLE CLAMP
8	2200-0103	2	SCREW-MACH 440 .250 PNPD
9	0515-0866	2	SCREW-MACH M3.0 X 8MM
10	5001-8767	1	CARD CAGE
11	5021-9395	9	EXTRUSION, CIRCUIT ENCLOSURE

Figure 4-6. Spectrum Analyzer Parts Identification, IF Assembly

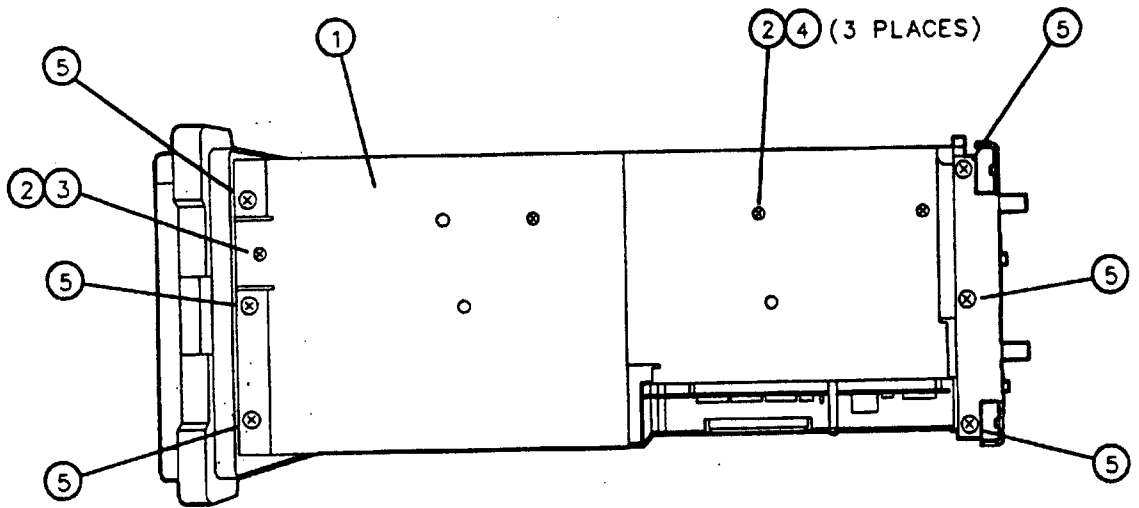

RIGHT SIDE

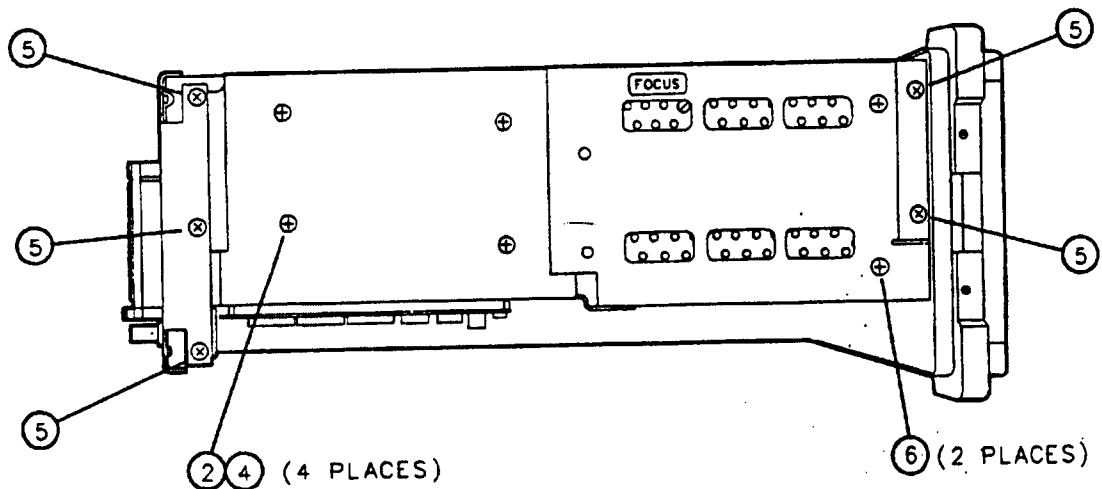

LEFT SIDE

Item	HP Part Number	CD	Description
1	5001-8766	0	CHASSIS
2	3050-0105	6	WASHER-FLAT .125ID
3	0515-1468	9	SCREW-MACH M3.0 40 SEMPNPD
4	0515-2087	0	SCREW-SQBU M3.0x6MM TORX-HD
5	0515-1367	7	SCREW-MACH M4.0 8 PCFLPDS
6	0515-0808	9	SCREW-ST M4.0 12 PNP

Figure 4-7. Spectrum Analyzer Parts Identification, Miscellaneous Chassis

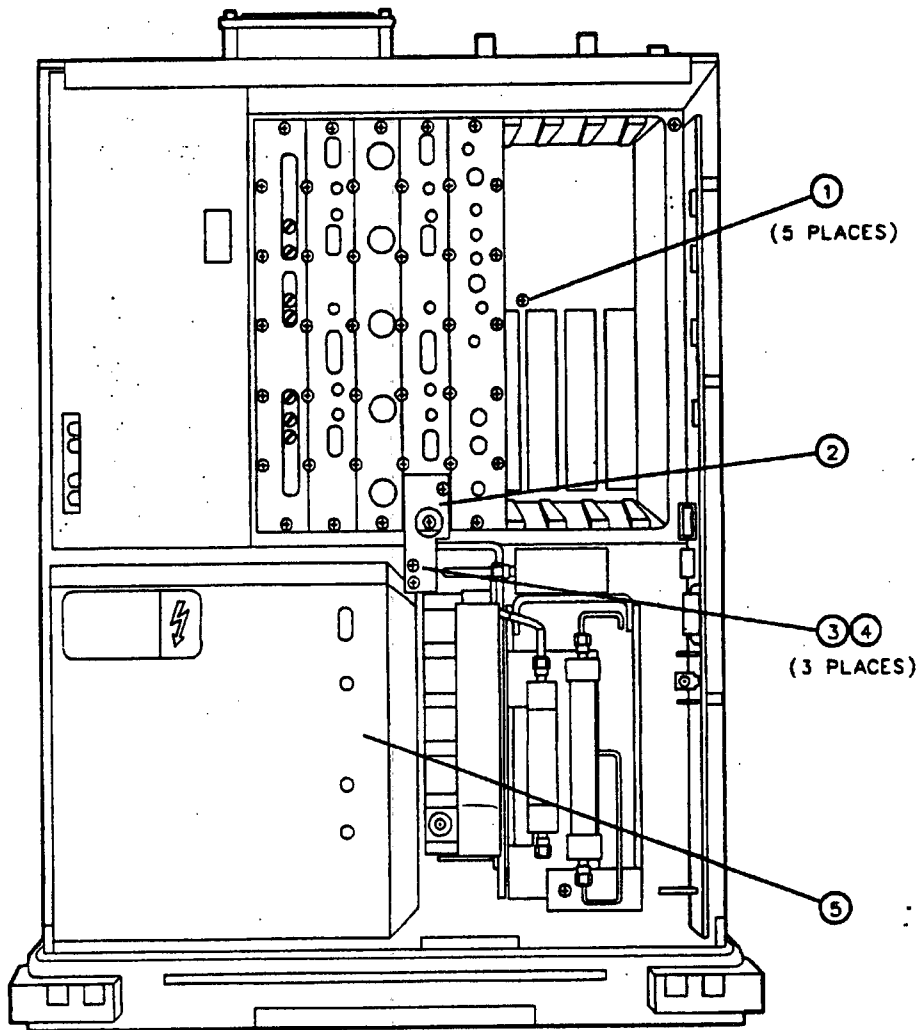

Item	HP Part Number	CD	Description
1	0515-0866	9	SCREW-MACH M3.0 8 CWPNPDS
2	5002-0618	7	FRONT END TO IF SUPPORT BRACKET
3	0515-0866	9	SCREW-MACH M3.0 8 CWPNPDS
4	3050-0893	9	WASHER-FLAT M4.0ID
5	08590-00006	1	DISPLAY SHIELD

Figure 4-8. Spectrum Analyzer Parts Identification, Miscellaneous Chassis

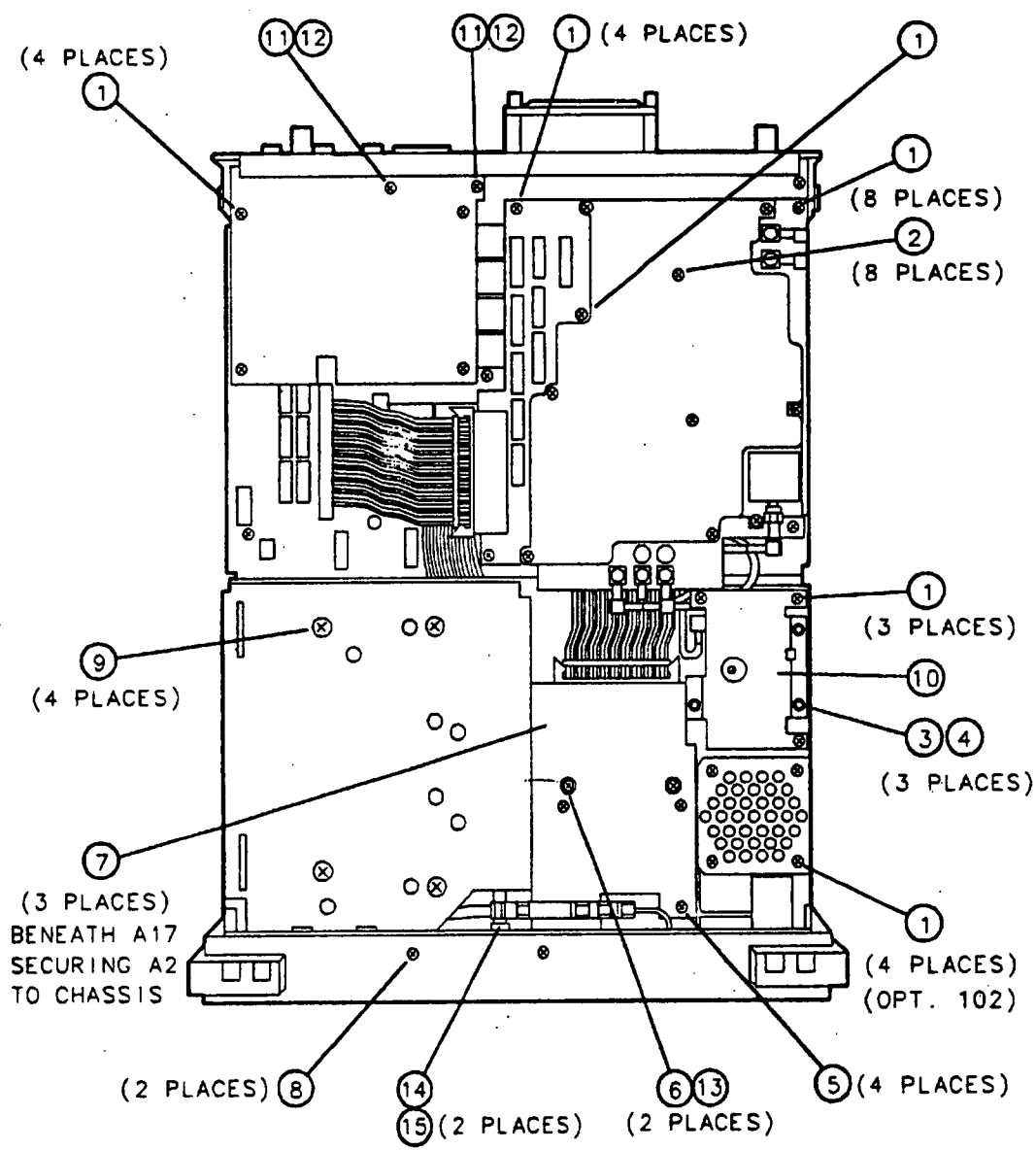
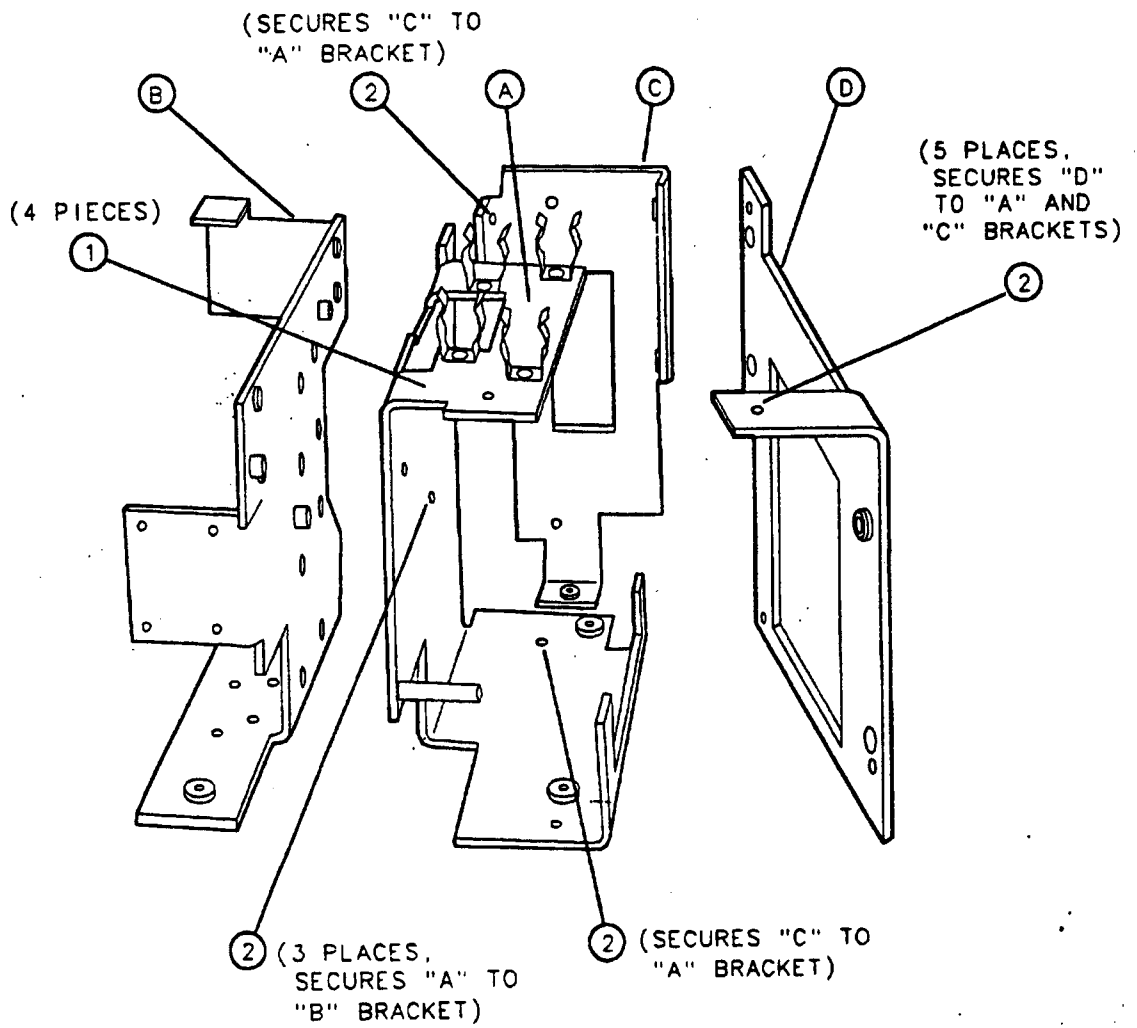

Figure 4-9. Spectrum Analyzer Parts Identification, Miscellaneous Chassis (1 of 2)

Item	HP Part Number	CD	Description
1	0515-0866	9	SCREW-MACH M3.0 8 CWPNPDS
2	0515-1532	0	SCREW-MACH M3.0 10 PNPDS
3	3050-0893	9	WASHER-FLAT M4.0ID
4	0535-0031	2	NUT-MACH WLKWR M3.0
5	0515-0866	9	SCREW-MACH M3.0 8 CWPNPDS
6	0515-1453	0	SCREW-MACH M3.0 12 SEMPNPD
7	0515-0808	9	SCREW-ST M4.0 12 PNP
8	0515-1110	8	SCREW-MACH M3.0 12 PCPNPDS
9	0515-0898	7	SCREW-MACH M4.0 6 PCPNPDS
10	5002-0635	8	OCXO MOUNTING BRACKET
11	2200-0109	8	SCREW-MACH .438 PNP (OPTION 021)
	0515-0169	5	SCREW-MACH M3.0 10SEMPNPD (OPTION 023)
12	2190-0587	3	WASHER-LK M5.0ID (OPTION 021)
	0535-0025	4	NUT-DBLHXS M3.0 (OPTION 023)
13	3050-0105	6	WASHER, FLAT .125ID
14	9170-0555	0	INPUT CABLE TORRIOD
15	1400-0249	0	CABLE TIE .062D .09W

Figure 4-9. Spectrum Analyzer Parts Identification, Miscellaneous Chassis (2 of 2)



Item	HP Part Number	CD	Description
1	08592-00009	6	RF BRACKET - 4 PIECES
2	0515-0866	9	SCREW M3.0 X 8MM PAN-HD

Figure 4-10. Spectrum Analyzer Parts Identification, Front-End Bracket Assembly

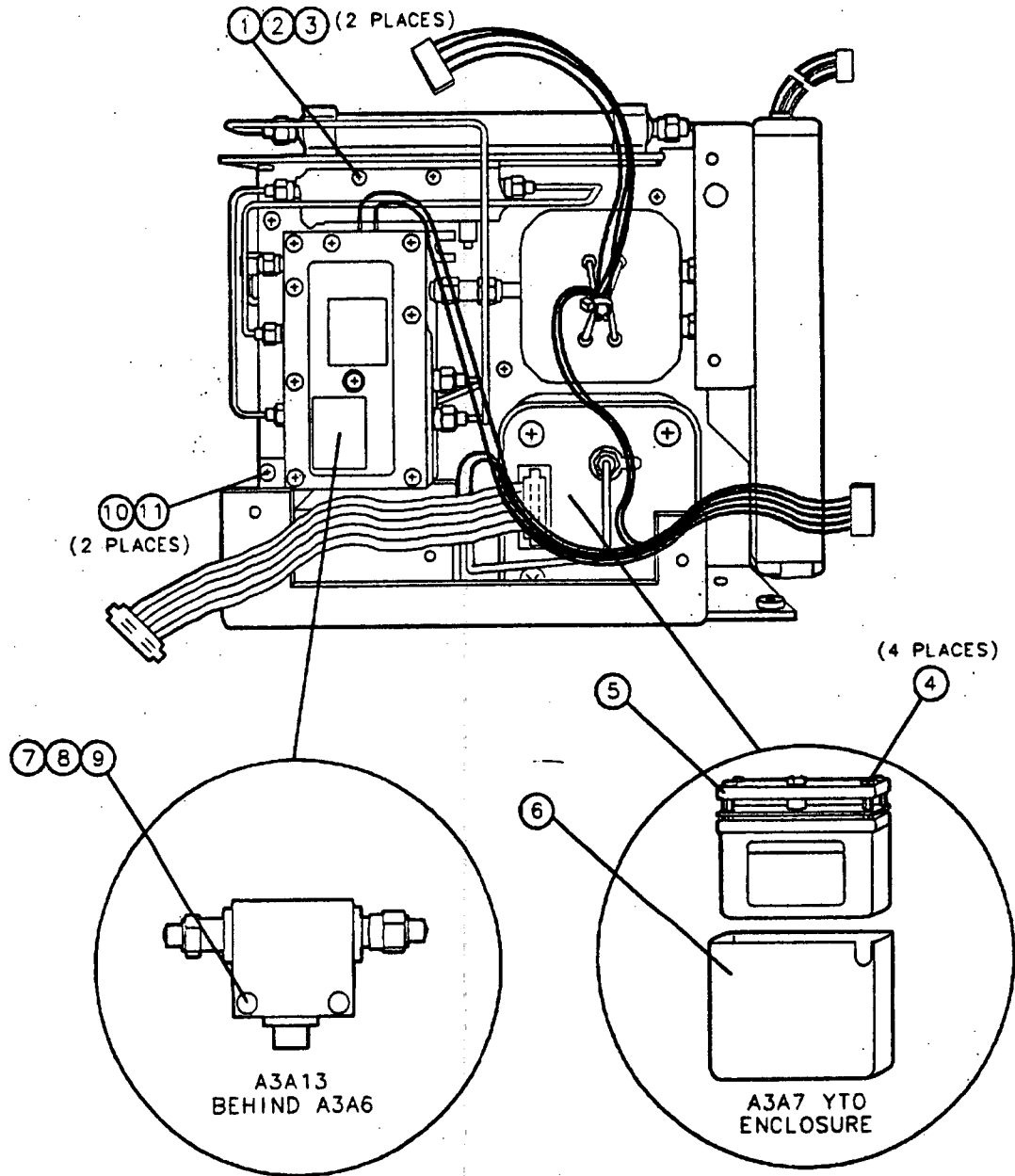
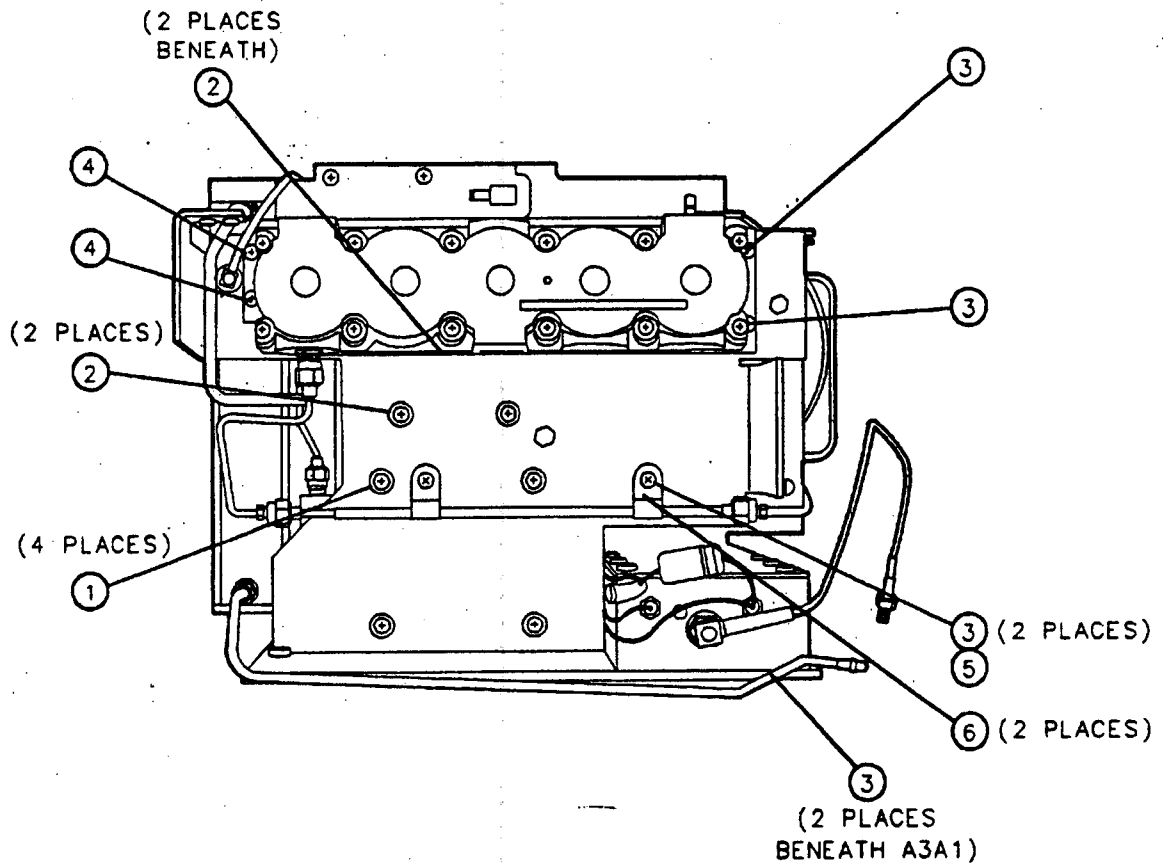

Figure 4-11. Spectrum Analyzer Parts Identification, Front-End Right-Side View (1 of 2)

Item	HP Part Number	CD	Description
1	0515-1373	5	SCREW M2.5 X 16MM PAN-HD
2	2190-0583	9	LOCK WASHER M2.5ID
3	0535-0070	9	HEX NUT M2.5
4	2360-0111	0	SCREW 3-32 X .188 PAN-HD
5	7100-1308	4	COVER SHIELD FOR EYO
6	7100-1309	5	CAN SHIELD FOR EYO
7	0515-0973	9	SCREW M2.0 X 20MM PAN-HD
8	2190-0654	5	WASHER, LOCK M2.0ID
9	0535-0069	6	HEX NUT M2.0
10	0515-0866	9	SCREW M3.0 X 8MM PAN-HD
11	3050-0105	6	FLAT WASHER .125ID

Figure 4-11. Spectrum Analyzer Parts Identification, Front-End Right-Side View (2 of 2)



Item	HP Part Number	CD	Description
1	2360-0117	6	SCREW 6-32 X .375 PAN-HD
2	2360-0117	6	SCREW 6-32 X .375 PAN-HD
3	0515-0866	9	SCREW M3.0 X 8MM PAN-HD
4	0515-1462		SCREW M3.0 X 16MM PAN-HD
5	3050-0105	6	FLAT WASHER .125ID
6	1400-0053	4	CABLE CLIP .17D .37W

Figure 4-12. Spectrum Analyzer Parts Identification, Front-End Left-Side View

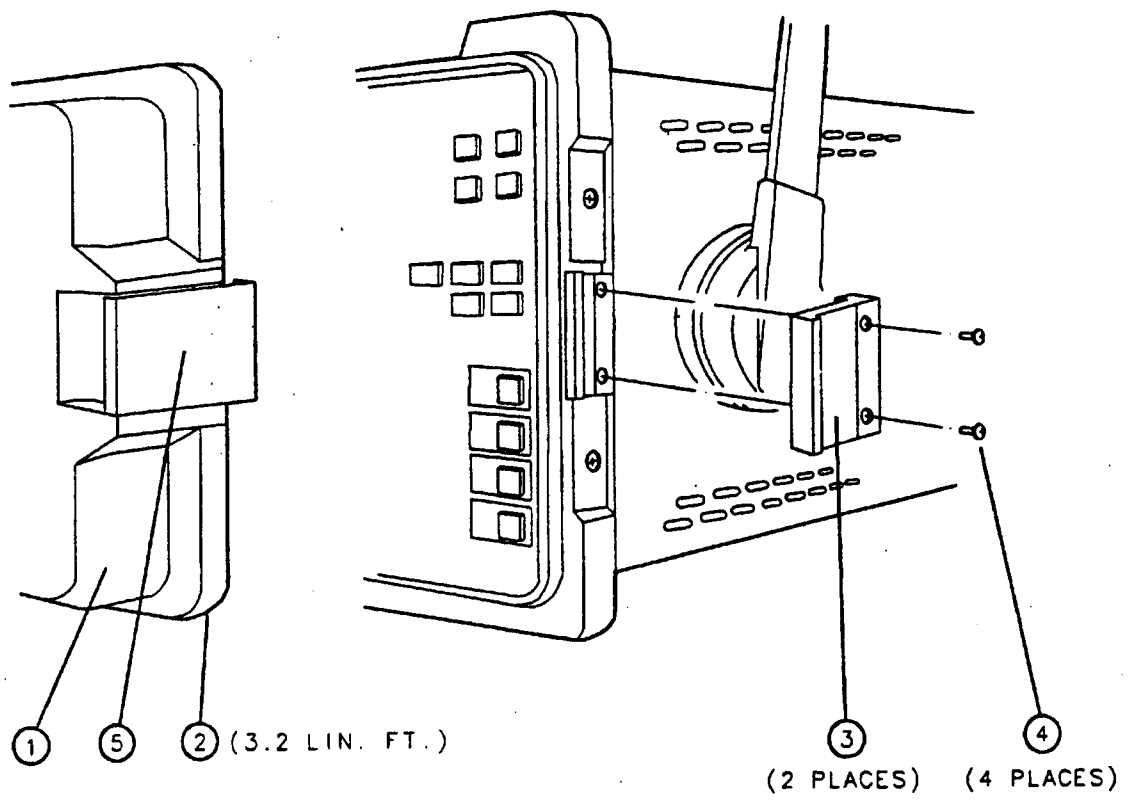

Item	HP Part Number	CD	Description
1	5062-4805	8	IMPACT COVER ASSEMBLY
2	5041-7235	0	GASKET, 3.2 FT.
3	5021-5483	4	CATCH LATCH
4	0515-0894	3	SCREW-MACH M2.5 6MM-LG PAN-HD
5	5062-0730	0	DRAW CATCH ASSEMBLY

Figure 4-13. Spectrum Analyzer Parts Identification, Impact Cover

Major Assembly and Cable Locations

Introduction

The various assemblies and cables of the spectrum analyzer are illustrated in this chapter. Refer to Chapter 4, "Replaceable Parts," for part numbers, assembly descriptions, and ordering information.

Contents

Figure	Page
5-1. HP 8595A A1 Front-Frame Assembly, Front and Rear Views	5-3
5-2. HP 8595A Top View	5-4
5-3. HP 8595A Card-Cage Options, Top View (Options 101, 102, 301).....	5-5
5-4. HP 8595A Card-Cage Options, Top View (Options 009, 010)	5-6
5-5. HP 8595A Card-Cage Options, Top View (Options 103)	5-7
5-6. HP 8595A Bottom View	5-8
5-7. HP 8595A Options, Bottom View	5-9
5-8. HP 8595A A3 Front-End Assembly, Top and Left-Side Views	5-10
5-9. HP 8595A A3 Front-End Assembly, Right-Side View	5-11
5-10. HP 8595A A3 Front-End Assembly, Rear View with A3A5 Removed	5-12
5-11. HP 8595A A3 Front-End Assembly, Right-Side View (Option 009, 010)	5-13
5-12. HP 8595A A3 Front-End Assembly, Rear View with A3A5 Removed (Option 009, 010)	5-14

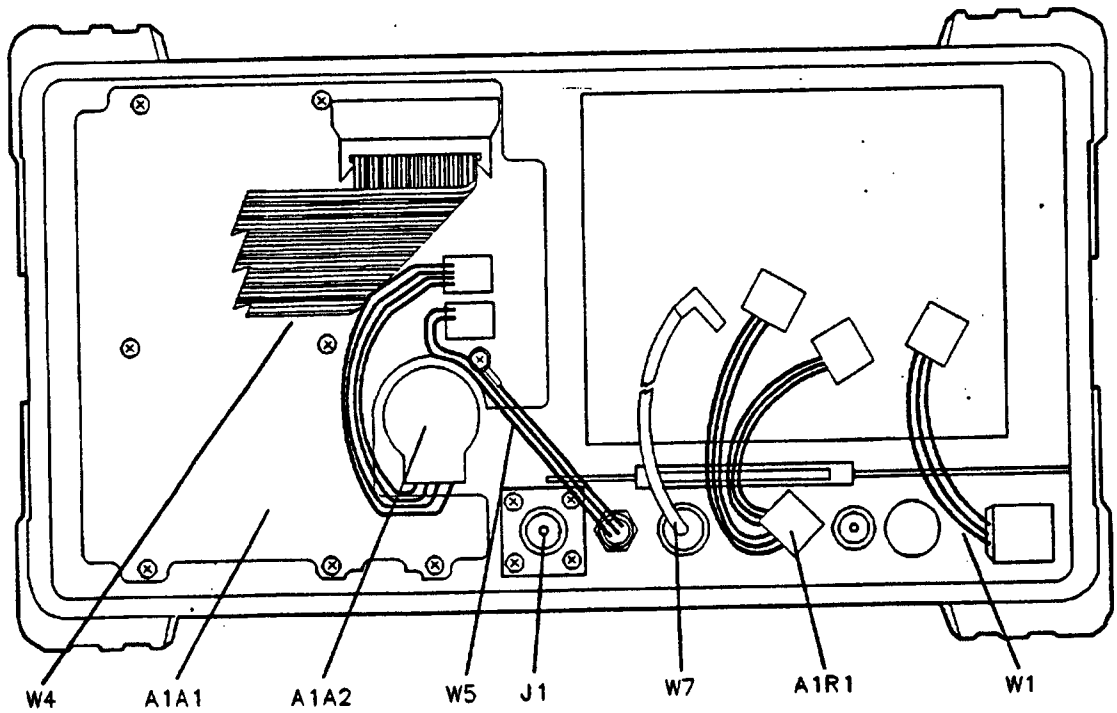
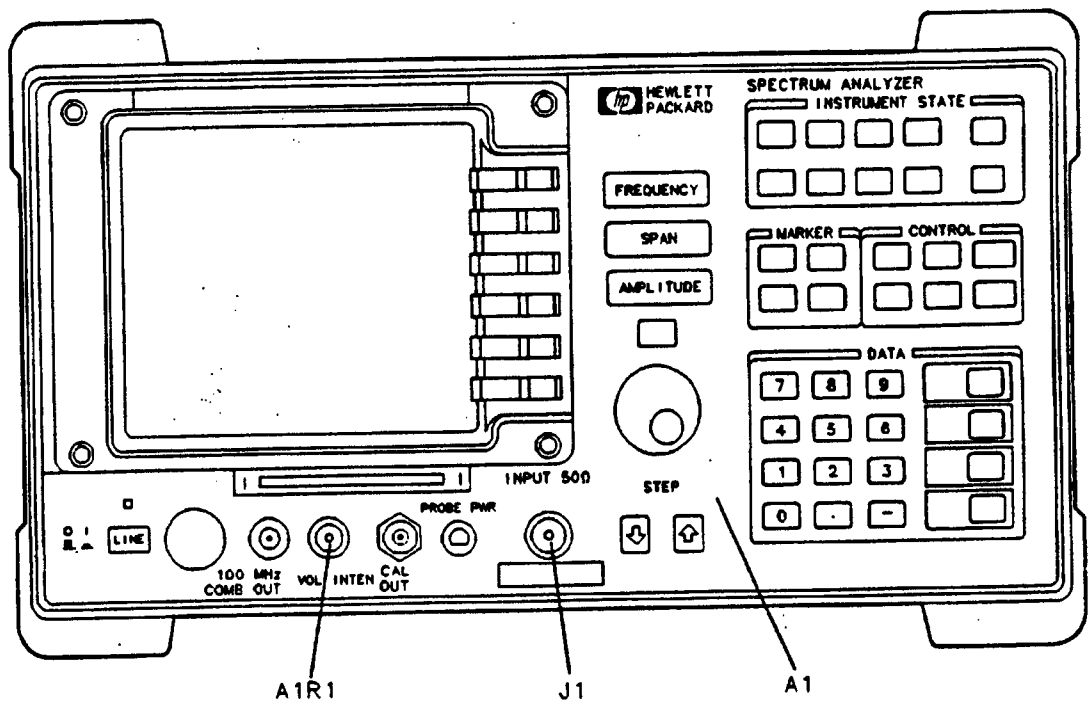

Figure 5-1. HP 8595A A1 Front-Frame Assembly, Front and Rear Views

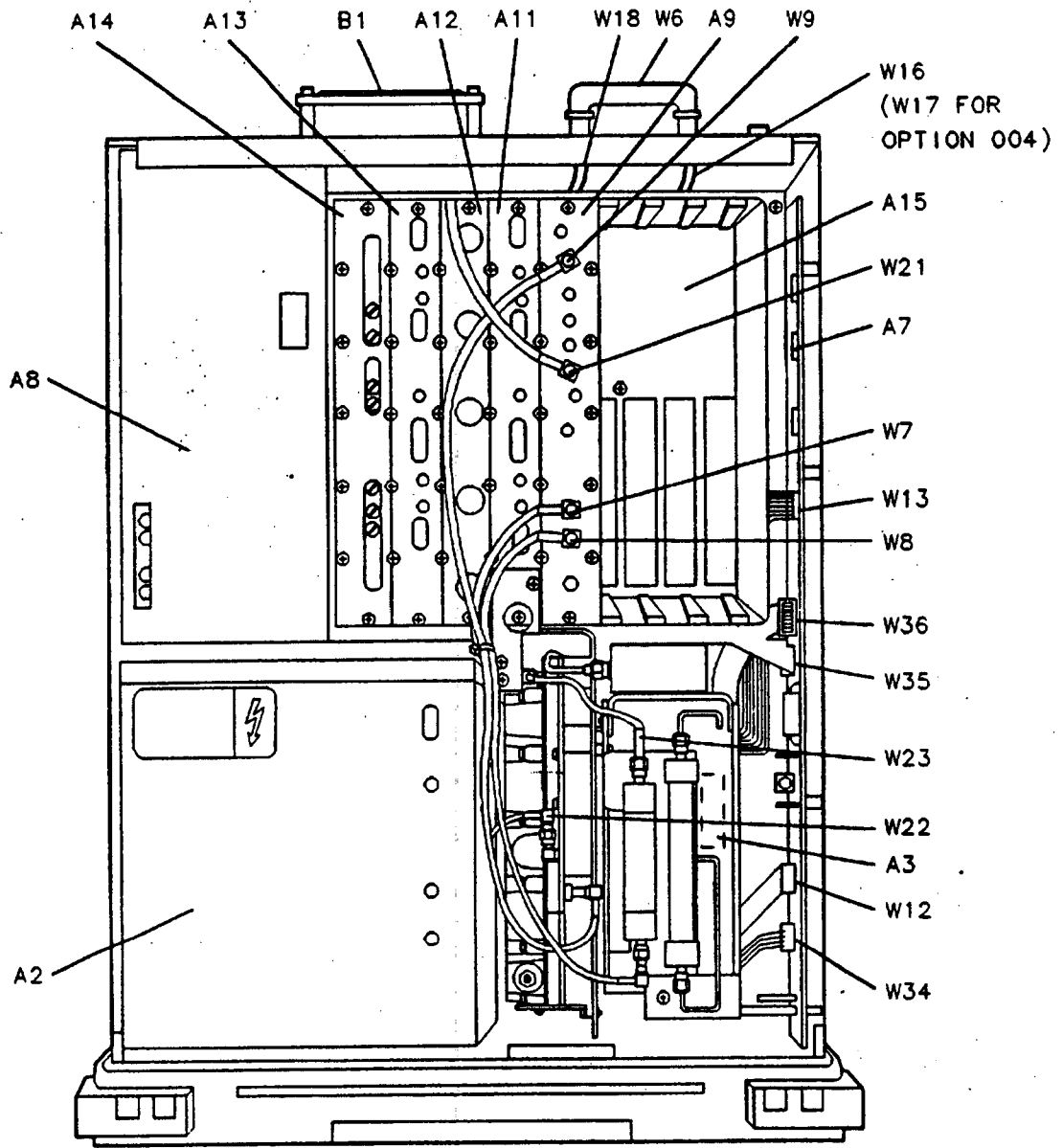

Figure 5-2. HP 8595A Top View

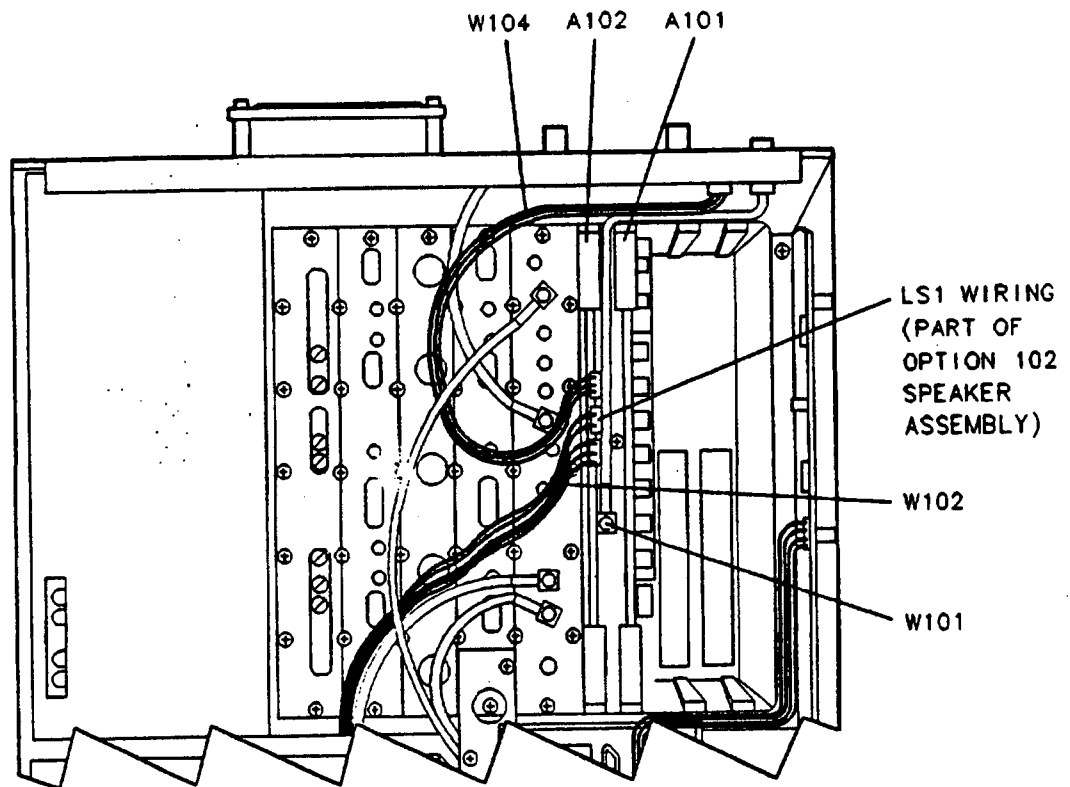

Figure 5-3. HP 8595A Card-Cage Options, Top View (Options 101, 102, 301)

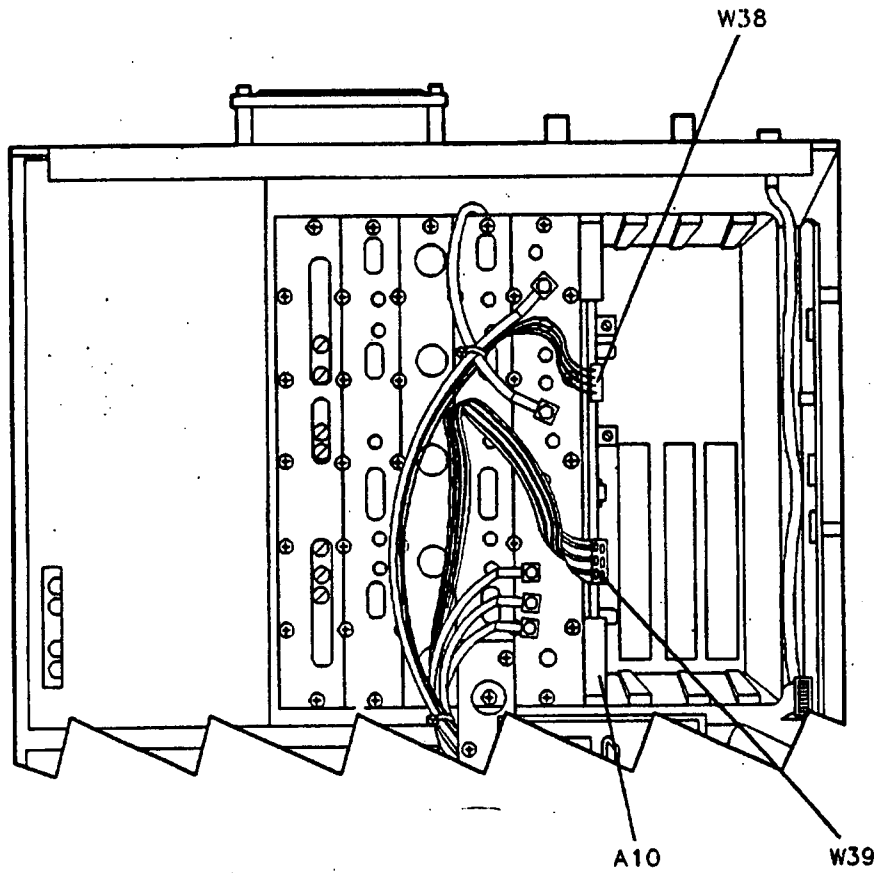

Figure 5-4. HP 8595A Card-Cage Options, Top View (Options 009, 010)

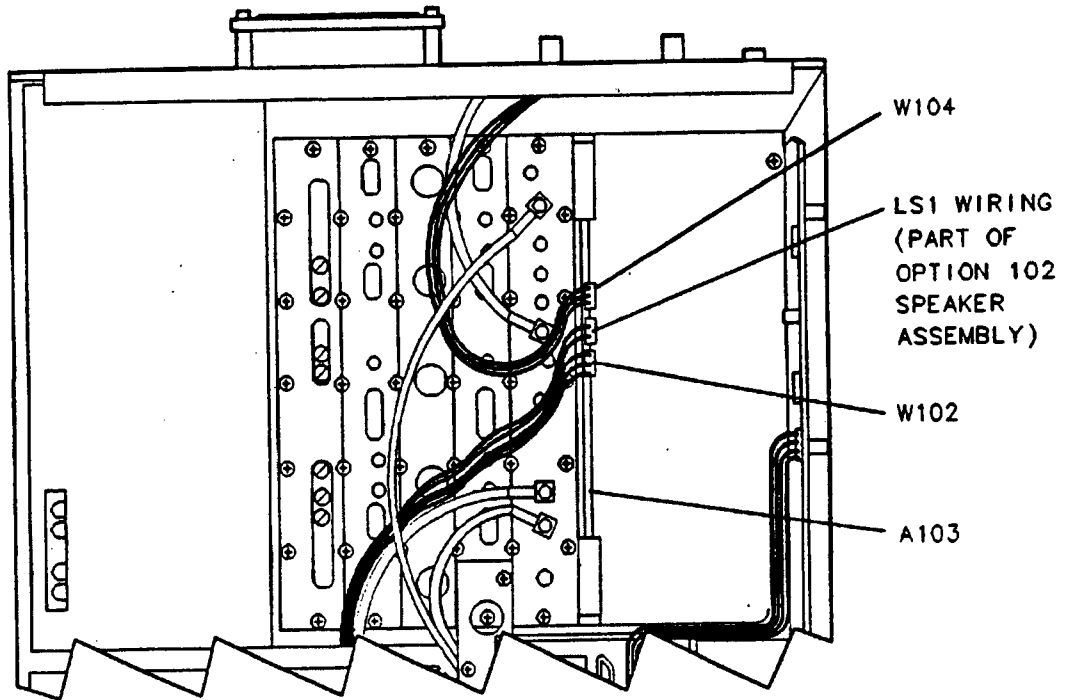

Figure 5-5. HP 8595A Card-Cage Options, Top View (Options 103)

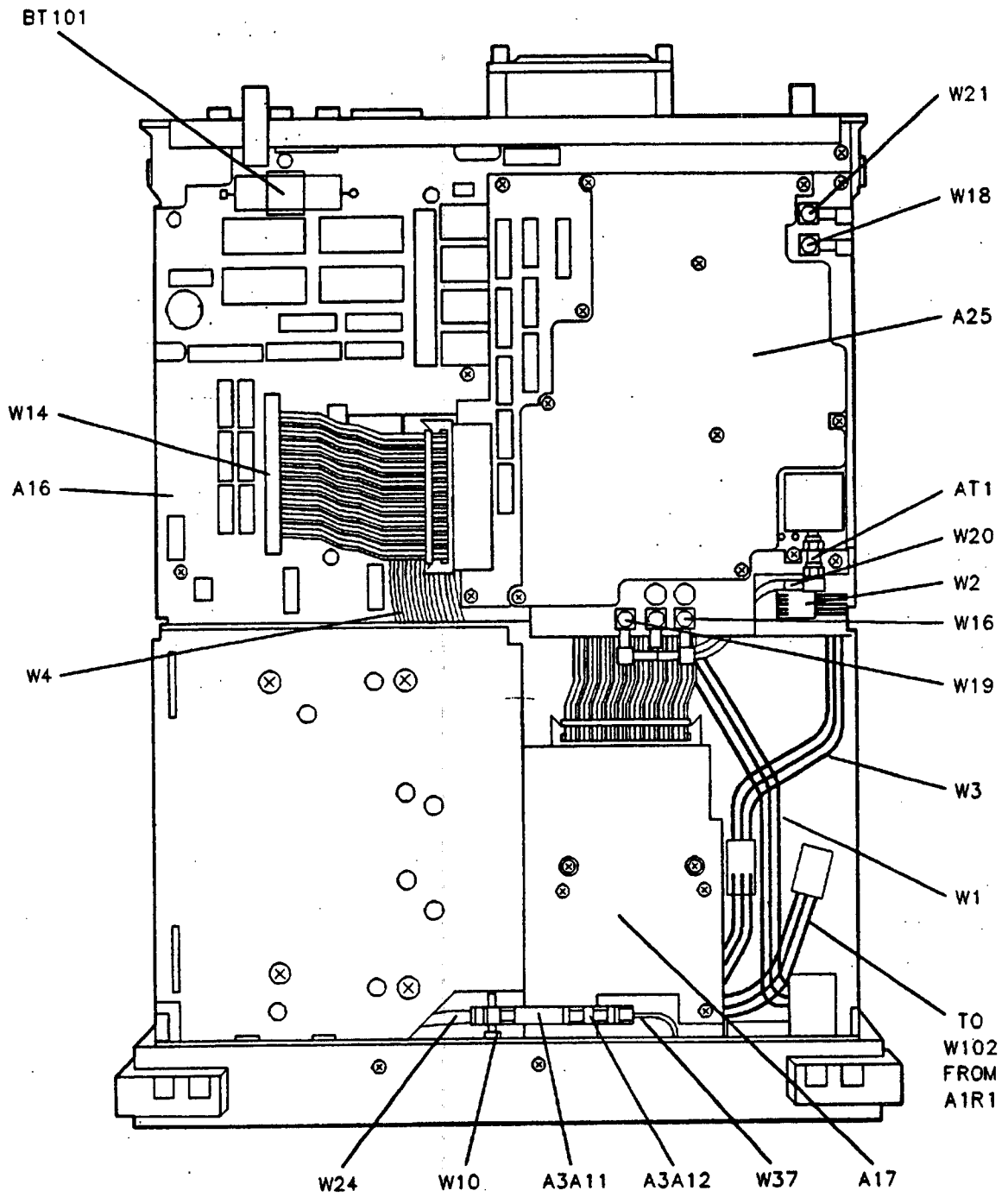

Figure 5-6. HP 8595A Bottom View

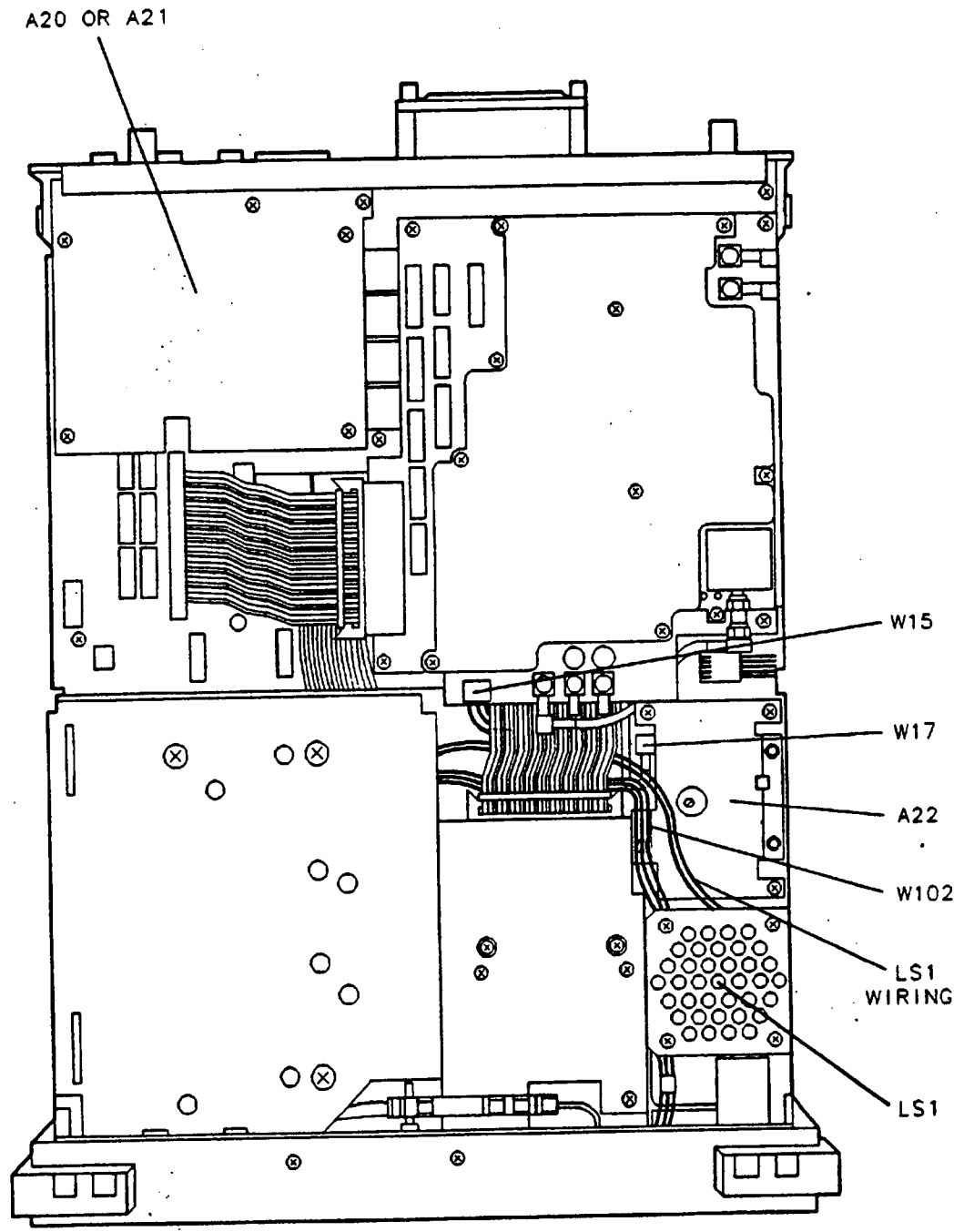

Figure 5-7. HP 8595A Options, Bottom View

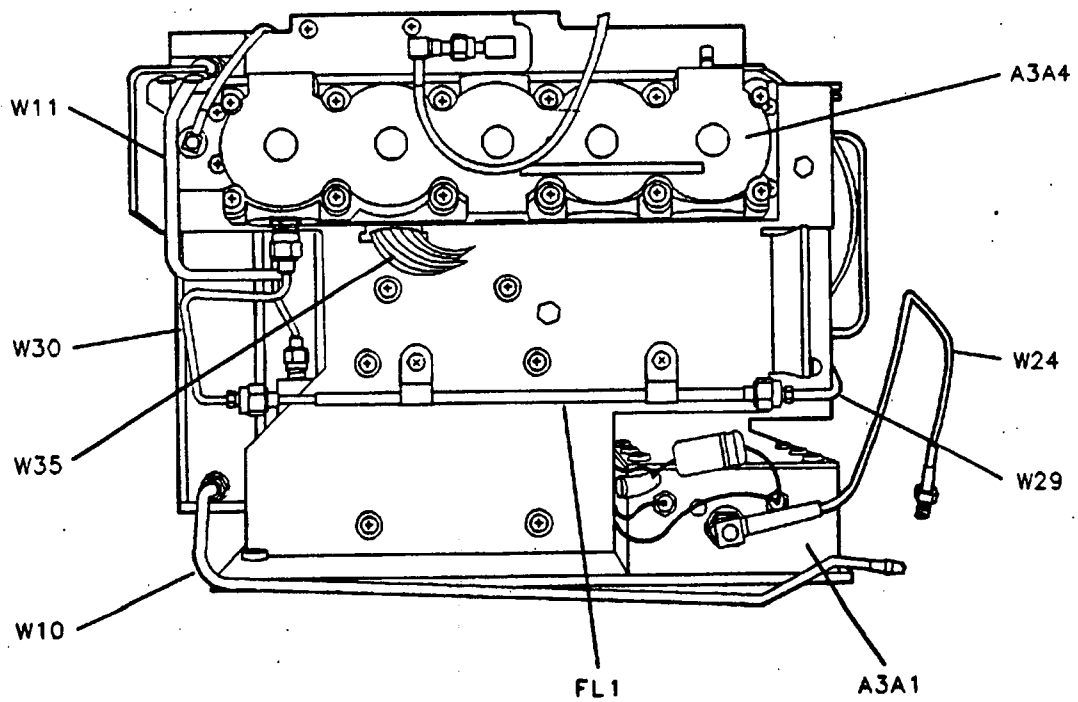
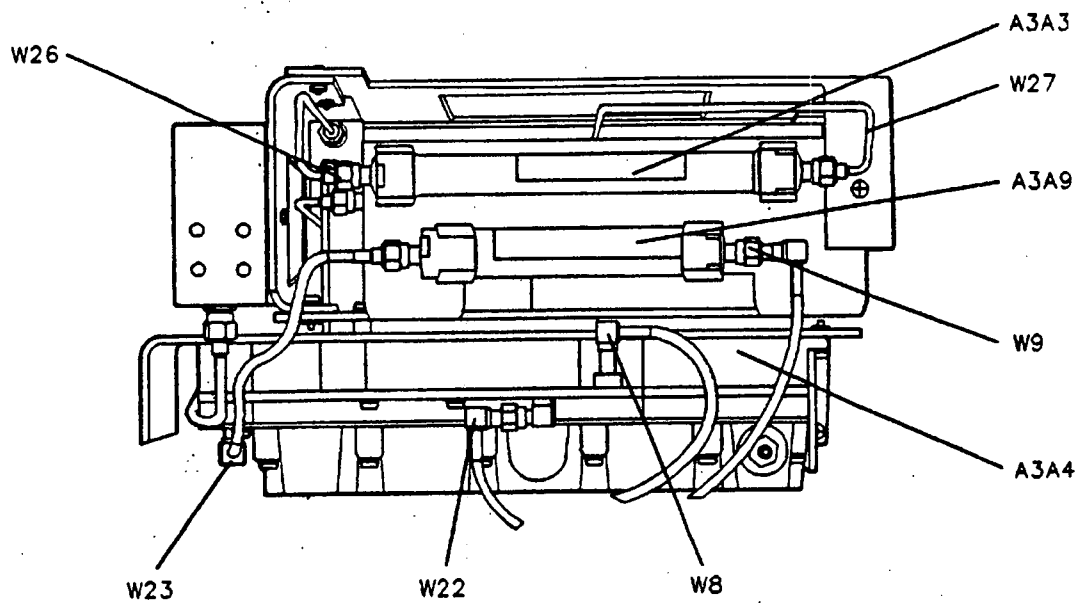

Figure 5-8. HP 8595A A3 Front-End Assembly, Top and Left-Side Views

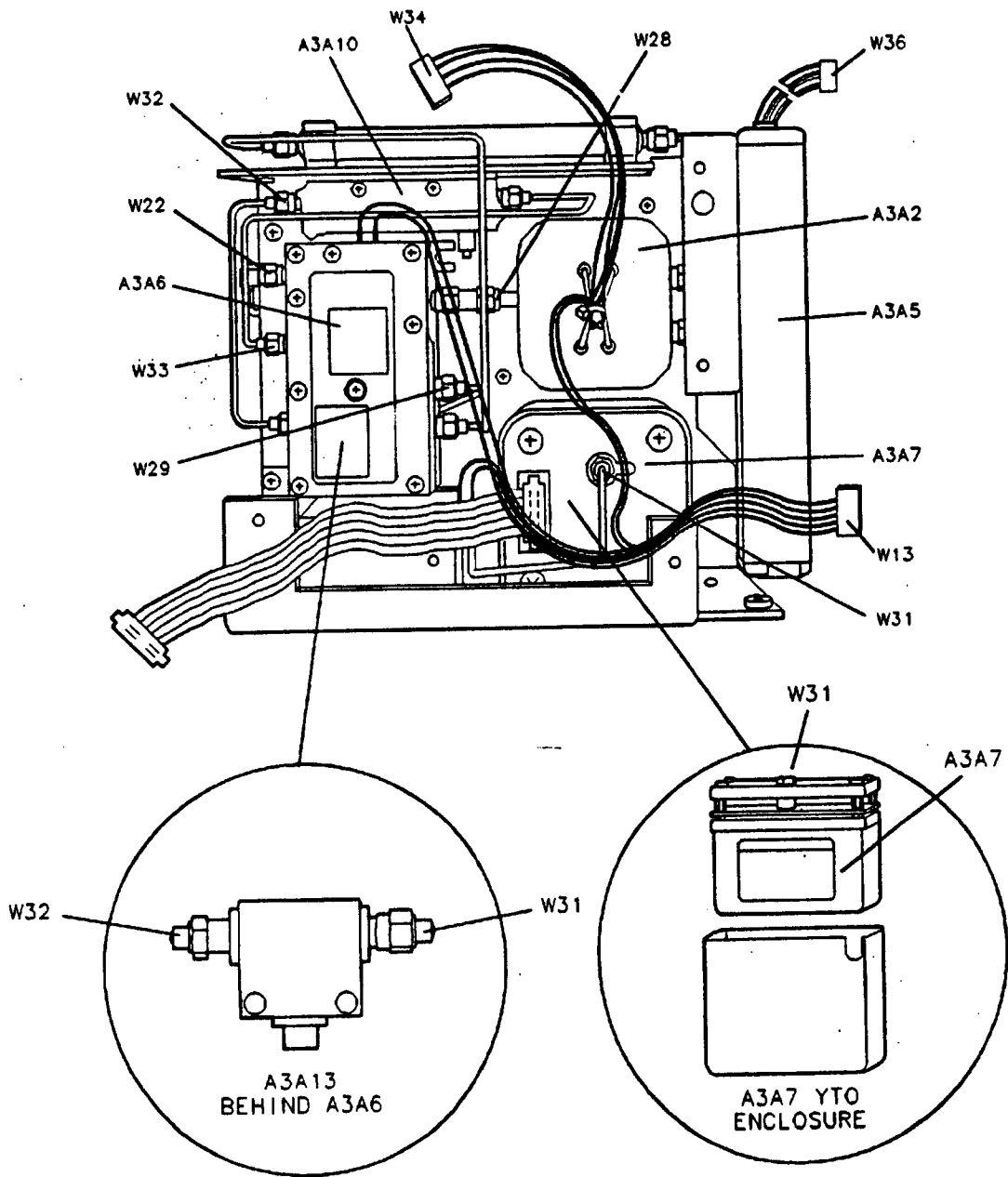

Figure 5-9. HP 8595A A3 Front-End Assembly, Right-Side View

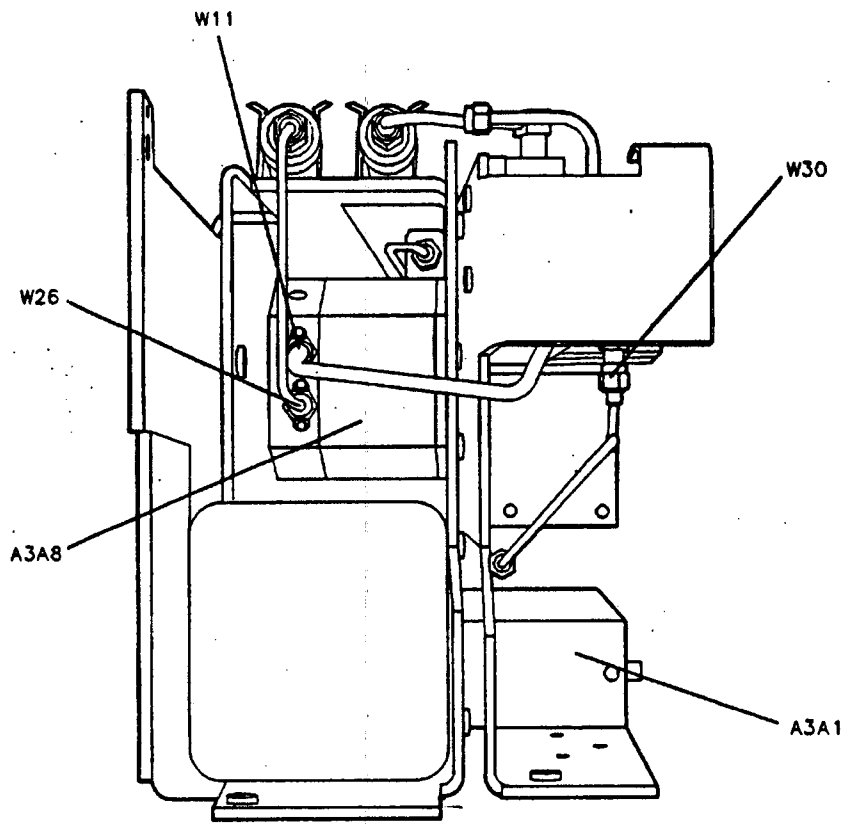

Figure 5-10. HP 8595A A3 Front-End Assembly, Rear View with A3A5 Removed

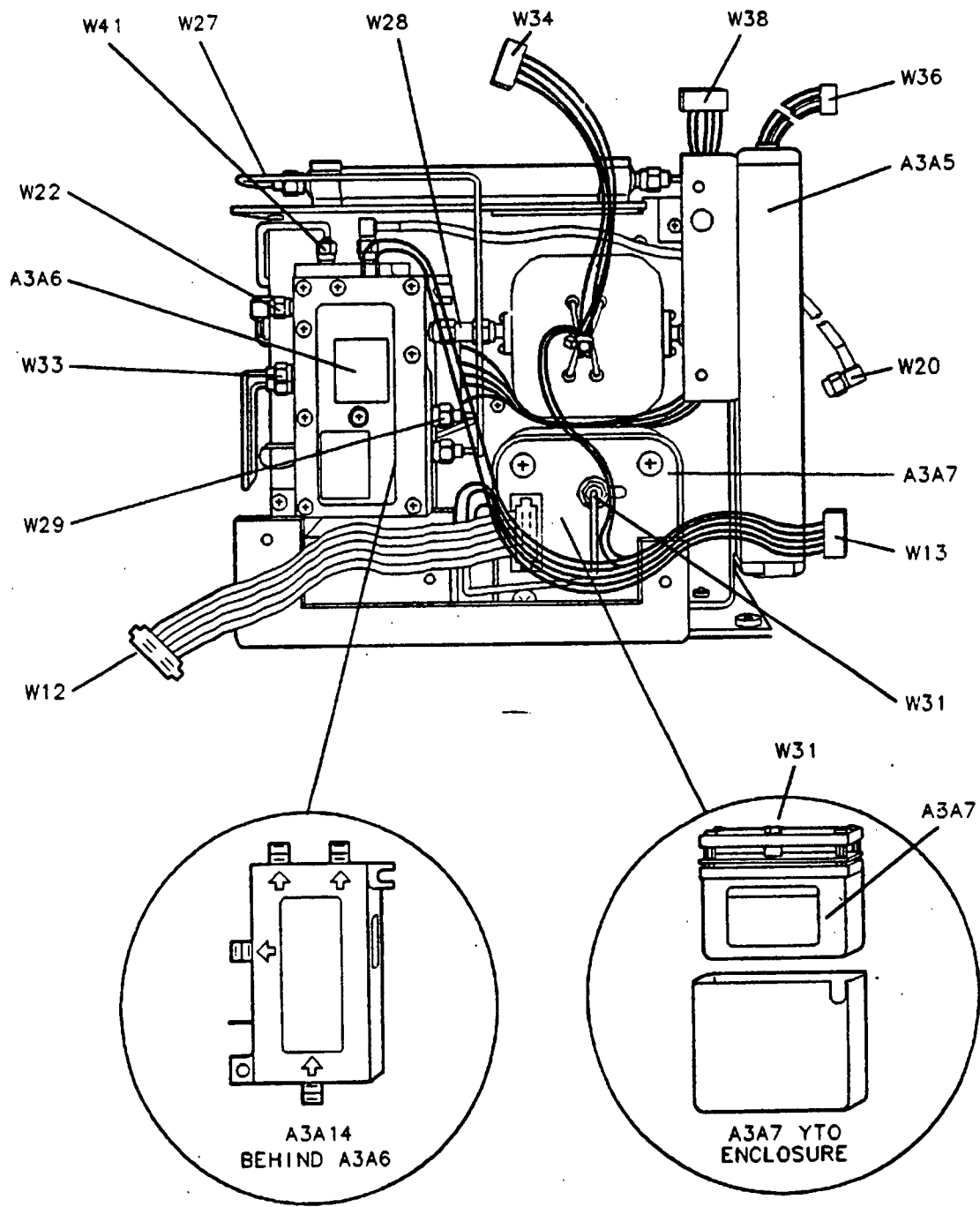

Figure 5-11. HP 8595A A3 Front-End Assembly, Right-Side View (Option 009, 010)

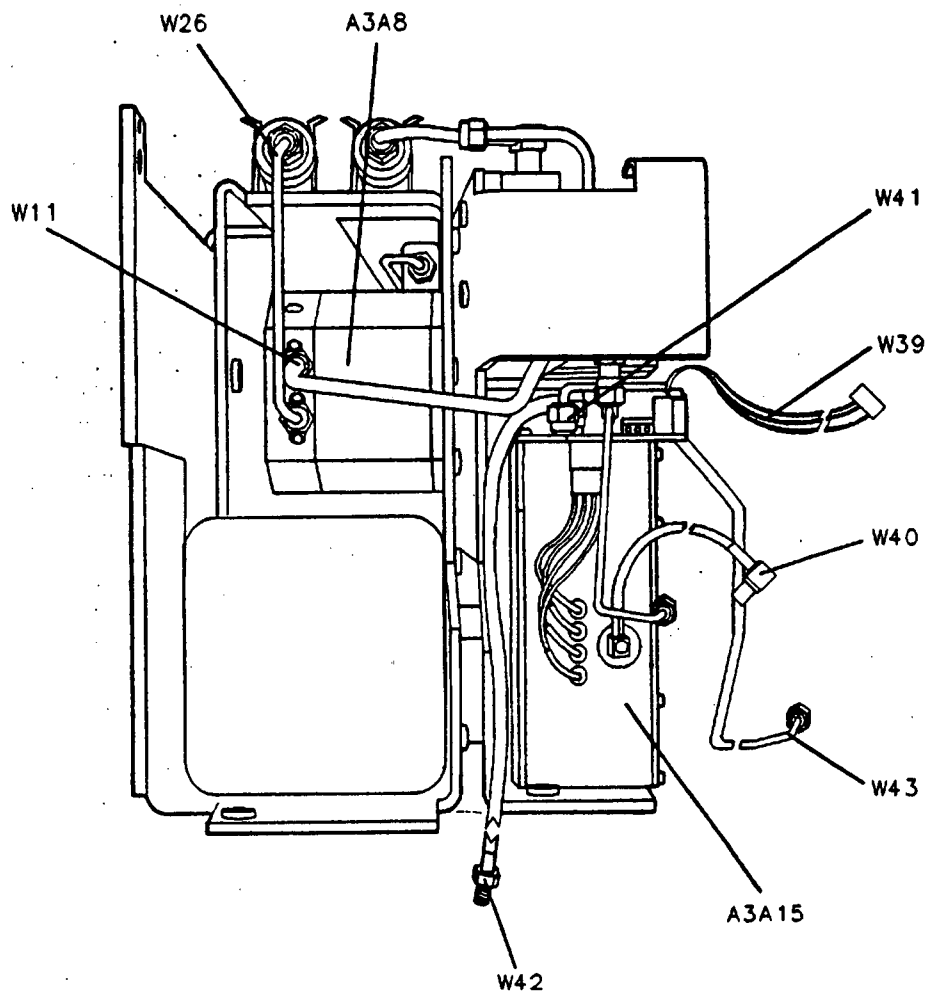

Figure 5-12.
HP 8595A A3 Front-End Assembly, Rear View with A3A5 Removed (Option 009, 010)

General Troubleshooting

Introduction

This chapter describes the operation of the HP 8595A spectrum analyzer and provides information that is useful when working on an instrument failure. Refer to "Chapter Organization" for an overview of the troubleshooting information provided in this chapter and the chapters that follow.

Component-level information for the HP 8595A spectrum analyzer is provided in the *HP 8590 Series Portable Spectrum Analyzers Component-Level Information* binder. Refer to Appendix A for a list of available component-level service information.

Before You Start Troubleshooting

There are three things you must do *before* you begin troubleshooting an instrument failure:

- Familiarize yourself with the safety symbols marked on the spectrum analyzer, and read the general safety instructions and the symbol definitions given in the front of this manual.
- The spectrum analyzer contains static sensitive components. Read the section entitled "Protection From Electrostatic Discharge" in Chapter 1.
- Become familiar with the organization of the troubleshooting information in this chapter and the chapters that follow.

Warning



The spectrum analyzer contains potentially hazardous voltages. Refer to the safety symbols on the spectrum analyzer and the general safety instructions in this manual before operating the unit with the cover removed. Failure to heed the safety precautions can result in severe or fatal injury.

Chapter Organization

This section provides the organization of the general troubleshooting information contained in this chapter and the more detailed troubleshooting information contained in Chapter 7 through Chapter 11.

Chapter 6, "General Troubleshooting"

The first part of the chapter provides an overview of instrument operation and procedures for measuring power levels along the signal path from the spectrum analyzer input to the A16 Processor/Video assembly:

- Table 6-1, Assembly-to-Functional-Block Matrix. Provides an overview of the assemblies that are part of each functional section within the spectrum analyzer.
- Table 6-2, Adjustments and Tests for Replaced or Repaired Assemblies. Directs the user to adjustment and testing information to ensure that the spectrum analyzer meets its specifications after the replacement or repair of individual assemblies.
- Figure 6-1, Graphic Symbols Used on Schematic and Block Diagrams. Defines the symbols used on the block diagrams in this chapter.
- "RF and LO Section Overview." Provides an introduction to the operation of the RF and LO sections.
- "Instrument Settings for RF Power Level Measurement." Provides procedures for taking power-level measurements in the RF section at the points shown on Foldout 6-1.
- Table 6-3, RF Power Levels at Measurement Points. Provides power levels for the measurement points shown on Foldout 6-1. The indicated power levels are valid only when the spectrum analyzer settings provided prior to the table are used.
- Foldout 6-1, RF Section Overall Block Diagram. Provides an overall block diagram of the RF and LO sections.
- "IF, Video, and Instrument Control Overview." Provides an introduction to the operation of the IF and Processor/Video assemblies.
- "IF Power Levels at Measurement Points." Provides procedures for taking power-level measurements in the IF section at the points shown on Foldout 6-2. The indicated power levels are valid only when the spectrum analyzer settings provided in the procedure are used.
- Foldout 6-2, IF/Control Overall Block Diagram. Provides an overall block diagram of the IF, instrument control, and display sections.

The second part of Chapter 6 provides troubleshooting procedures that are useful when first starting to troubleshoot a spectrum analyzer failure:

- "Problems at Instrument Power-Up." Provides troubleshooting procedures for failures that occur when the spectrum analyzer is first turned on.
- "Troubleshooting an Inoperative Spectrum Analyzer." Provides troubleshooting procedures to use when there is little evidence of what caused the spectrum analyzer to fail.
- "A2 Display Troubleshooting." Provides procedures for troubleshooting display problems.
- "Locating an RF/LO/IF or Video Problem." Provides procedures for isolating a failure to the RF, LO, IF or Video section.

Chapter 7, "RF/LO Section Troubleshooting"

This chapter provides further troubleshooting information for the RF and LO sections.

- "RF Section Information." Provides a detailed block diagram of the RF section and additional information about the RF section.
- "LO Section Information." Provides a detailed block diagram of the LO section and additional information about the LO section.
- "A9 Third Converter Assembly." Provides a detailed block diagram of the A9 assembly and additional A9 information.
- "A25 Counter Lock Assembly." Provides a detailed block diagram of the A25 assembly and additional information about A25 operation.
- "A3A14 First LO Distribution Amplifier." Provides information about A3A14 operation.
- "A3A15 Tracking Generator." Provides a detailed block diagram of the A3A15 assembly and additional information about A3A15 operation.

Chapter 8, "IF Section Troubleshooting"

This chapter provides further troubleshooting information for the IF section.

- "IF Section Information." Provides an overview of the individual gain stages for each IF assembly. Control line tables, which match the control lines for each IF assembly with their corresponding spectrum analyzer settings, are also provided.
- "A15 Motherboard Assembly." Provides specific details for tracing signals that pass through the A15 Motherboard.

Chapter 9, "Control/Display Section Troubleshooting"

This chapter provides information about the correction data stored in memory on the A16 Processor/Video assembly and the operation of the A7 Analog Interface assembly.

- "Backing Up Spectrum Analyzer Correction Constants." Provides procedures for recording the correction constant data and restoring the data to instrument memory.
- "A16 Memory Reset." Provides procedures for initializing instrument memory and recalibrating the instrument after an instrument memory failure.
- "Spectrum Analyzer Recovery after a A16 Memory Loss." Provides procedures for restoring correction constants to spectrum analyzer memory, initializing lost spectrum analyzer settings, and recalibrating the spectrum analyzer, after a A16 memory failure.
- "A7 Analog Interface Assembly." Provides a detailed block diagram of the A7 assembly and additional A7 information. Chapter 8 provides further control details for the assemblies that are controlled by the A16 assembly using various control voltages from the A7 assembly.

Chapter 10, "Softkey Descriptions"

This chapter provides information about the calibration, service, and diagnostic softkey functions. Details about the instrument passcodes, the instrument correction data, and the function of each service-related softkey are also provided.

Chapter 11, "Analyzer Messages"

This chapter describes how to interpret the spectrum analyzer messages that appear during instrument operation or when a failure occurs. Troubleshooting hints for each spectrum analyzer error message are also provided.

Service Equipment

- Refer to Table 1-4 for the recommended test equipment needed to troubleshoot and repair the spectrum analyzer. Although Hewlett-Packard equipment is recommended, other equipment may be used, provided that it meets the specifications shown in the table.
- Refer to Table 1-5 for a list of required service tools, and Table 1-6 for recommended hand tools.

Replacement Assemblies

The following assemblies are not repairable to the component level and must be replaced as an assembly.

- A2 Display.
- A3A2 Switched YTF.
- A3A3 2.9 GHz Low-Pass Filter.
- A3A4 Second Converter.
- A3A5 Input Attenuator DC Block.
- A3A6 Dual Mixer.
- A3A7 YTO.
- A3A9 321.4 MHz Bandpass Filter.
- A3A14 First LO Distribution Amplifier (Option 009, 010)
- A3A15 Tracking Generator (Option 010)
- A8 Power Supply.
- A22 Precision Frequency Reference (Option 004).
- A25A1 Sampler.

Refer to Chapter 4 when ordering replacement assemblies.

After an Instrument Repair

If one or more spectrum analyzer assemblies have been repaired or replaced, perform the related adjustments and performance verification tests. Refer to Table 6-2, Adjustments and Tests for Replaced or Repaired Assemblies, for the related adjustments and performance verification tests required for each assembly.

Table 6-1. Assembly-to-Functional-Block Matrix

Assembly Description	Display/Control Section	RF Section	LO Section	IF Section
A1 Front Frame	x			
A2 Display	x			
A3A1 100 MHz Comb Generator		x		
A3A2 Switched YTF		x		
A3A3 2.9 GHz Low Pass Filter		x		
A3A4 Second Converter		x		
A3A5 Input Attenuator DC Block		x		
A3A6 Dual Mixer		x		
A3A7 YTO			x	
A3A9 321.4 MHz Bandpass Filter		x		
A3A10 Directional Coupler			x	
A3A11 Step Recovery Diode		x		
A3A12 3dB Attenuator		x		
A3A13 Isolator			x	
A3A14 LO Distribution Amplifier		x	x	
A3A15 Tracking Generator		x	x	
A7 Analog Interface	x	x	x	x
A8 Power Supply	x	x	x	x
A9 Third Converter		x	x	
A10 Tracking Generator Control		x	x	
A11 Bandwidth Filter				x
A12 Amplitude Control				x
A13 Bandwidth Filter				x
A14 Log Amplifier				x
A15 Motherboard	x			x
A16 Processor/Video Board	x			x
A17 Memory Card	x			
A25 Counter-Lock			x	
AT1 10 dB Attenuator			x	
FL1 3.9 GHz Low Pass Filter		x		
<i>Optional Assemblies</i>				
A20 HP-IB I/O, Option 021	x			
A21 RS-232 I/O, Option 023	x			
A22 Precision Frequency Reference, Option 004			x	
A101 Fast Time Domain Sweeps, Option 101	x			
A102 AM/FM Speaker and TV Sync Trigger, Option 102	x			
A103 Demod Quasi Peak, Option 103	x			
A105 Time Gate Spectrum Analysis, Option 105	x			

Table 6-2. Adjustments and Tests for Replaced or Repaired Assemblies

Replaced or Repaired Assembly	Related Adjustments and Adjustment Routines	Related Performance Verification Tests
A1 Front Frame	CAL AMPTD Adjustment Routine	Input Attenuator Accuracy Frequency Response Residual Responses
A2 Display	Display CAL AMPTD Adjustment Routine	Input Attenuator Accuracy Frequency Response Residual Responses
A3A1 Comb Generator	Comb Generator CAL YTF Adjustment Routine	Comb Generator Frequency Accuracy Input Attenuator Accuracy Frequency Response Residual Responses
A3A2 Switched YTF	CAL FREQ Adjustment Routine CAL AMPTD Adjustment Routine CAL YTF Adjustment Routine	Frequency Response Residual Responses
A3A3 2.9 GHz Low-Pass Filter	CAL FREQ Adjustment Routine CAL YTF Adjustment Routine CAL AMPTD Adjustment Routine	Frequency Response Residual Responses
A3A4 Second Converter	CAL FREQ Adjustment Routine CAL AMPTD Adjustment Routine CAL YTF Adjustment Routine	Noise Sidebands System Related Sidebands Frequency Response Other Input Related Spurious Spurious Response Displayed Average Noise Level Residual Responses
A3A5 Input Attenuator DC Block	CAL FREQ Adjustment Routine CAL AMPTD Adjustment Routine CAL YTF Adjustment Routine Frequency Response	Input Attenuator Accuracy Frequency Response Residual Responses
A3A6 Dual-Band Mixer	CAL FREQ Adjustment Routine CAL AMPTD Adjustment Routine CAL YTF Adjustment Routine CAL MXR Adjustment Routine Frequency Response	Noise Sidebands System Related Sidebands Frequency Response Other Input Related Spurious Spurious Response Gain Compression Displayed Average Noise Level Residual Responses

**Table 6-2.
Adjustments and Tests for Replaced or Repaired Assemblies (continued)**

Replaced or Repaired Assembly	Related Adjustments and Adjustment Routines	Related Performance Verification Tests
A3A7 YTO	First LO Distribution Amplifier Adjustment <i>(Tracking generator options only)</i> CAL FREQ Adjustment Routine CAL AMPTD Adjustment Routine CAL YTF Adjustment Routine	Frequency Readout Accuracy and Marker Count Accuracy Noise Sidebands System Related Sidebands Residual FM Frequency Span Readout Accuracy Frequency Response Other Input Related Spurious Spurious Response Residual Responses
A3A9 Bandpass Filter	CAL FREQ Adjustment Routine CAL AMPTD Adjustment Routine	None
A3A10 Directional Coupler <i>(Not used with Option 009, 010)</i>	CAL FREQ Adjustment Routine CAL AMPTD Adjustment Routine CAL YTF Adjustment Routine	System Related Sidebands Frequency Response Other Input Related Spurious Spurious Response Residual Responses
A3A11 Step-Recovery Diode	CAL FREQ Adjustment Routine CAL AMPTD Adjustment Routine	Comb Generator Frequency Accuracy
A3A12 3 dB Attenuator	CAL FREQ Adjustment Routine CAL AMPTD Adjustment Routine	None
A3A13 Isolator <i>(Not used with Option 009, 010)</i>	CAL FREQ Adjustment Routine CAL AMPTD Adjustment Routine CAL YTF Adjustment Routine	System Related Spurious Frequency Response Other Input Related Spurious Spurious Response Residual Responses
A3A14 First LO Distribution Amplifier <i>(Option 009, 010)</i>	First LO Distribution Amplifier Adjustment CAL FREQ Adjustment Routine CAL AMPTD Adjustment Routine CAL YTF Adjustment Routine	Frequency Readout Accuracy and Marker Count Accuracy Noise Sidebands System Related Sidebands Residual FM Frequency Span Readout Accuracy Frequency Response Other Input Related Spurious Spurious Response Residual Responses

**Table 6-2.
Adjustments and Tests for Replaced or Repaired Assemblies (continued)**

Replaced or Repaired Assembly	Related Adjustments and Adjustment Routines	Related Performance Verification Tests
A3A15 Tracking Generator <i>(Option 010)</i>	First LO Distribution Amplifier Adjustment CAL FREQ Adjustment Routine CAL AMPTD Adjustment Routine CAL YTF Adjustment Routine BITG Power Level Adjustments	Tracking Generator Absolute Amplitude and Vernier Accuracy Power Sweep Range Tracking Generator Level Flatness Harmonic Spurious Outputs Non-Harmonic Spurious Outputs Tracking Generator Feedthrough RF Power-Off Residuals Tracking Generator LO Feedthrough Amplitude
A7 Analog Interface	CAL FREQ Adjustment Routine CAL AMPTD Adjustment Routine CAL YTF Adjustment Routine	Frequency Readout Accuracy and Marker Count Accuracy Noise Sidebands System Related Sidebands Residual FM Frequency Span Readout Accuracy Sweep Time Accuracy Scale Fidelity Input Attenuator Accuracy Reference Level Accuracy Resolution Bandwidth Switching Uncertainty Frequency Response
A8 Power Supply	Power Supply	System Related Sidebands Spurious Response Residual Responses
A9 Third Converter	Third Converter Second IF Bandpass CAL FREQ Adjustment Routine CAL AMPTD Adjustment Routine BITG Power Level Adjustments <i>(Tracking generator options only)</i>	Noise Sidebands System Related Sidebands Calibrator Amplitude Accuracy Other Input Related Spurious Spurious Response Residual Responses
A10 Tracking Generator Control	First LO Distribution Amplifier Adjustment CAL FREQ Adjustment Routine CAL AMPTD Adjustment Routine CAL YTF Adjustment Routine BITG Power Level Adjustments	Frequency Response Tracking Generator Absolute Amplitude and Vernier Accuracy Tracking Generator Level Flatness

Table 6-2.
Adjustments and Tests for Replaced or Repaired Assemblies (continued)

Replaced or Repaired Assembly	Related Adjustments and Adjustment Routines	Related Performance Verification Tests
A11 First Bandwidth Filter	Crystal and LC Bandwidth Filter CAL FREQ Adjustment Routine CAL AMPTD Adjustment Routine	Scale Fidelity Resolution Bandwidth Switching Uncertainty
A12 Amplitude Control	CAL FREQ Adjustment Routine CAL Attenuator Error Correction CAL AMPTD Adjustment Routine	Scale Fidelity Displayed Average Noise Level
A13 2nd Bandwidth Filter	Crystal and LC Bandwidth Filter CAL FREQ Adjustment Routine CAL AMPTD Adjustment Routine	Scale Fidelity Resolution Bandwidth Switching Uncertainty
A14 Log Amplifier	Log and Linear Amplifier CAL FREQ Adjustment Routine CAL AMPTD Adjustment Routine	Scale Fidelity Reference Level Accuracy
A15 Motherboard	CAL FREQ Adjustment Routine CAL AMPTD Adjustment Routine	Operation Verification
A16 Processor/Video Board	10 MHz Reference (Standard) CAL FREQ Adjustment Routine CAL AMPTD Adjustment Routine CAL YTF Adjustment Routine CAL MXR Adjustment Routine* CAL Attenuator Error Correction* Frequency Response* Time and Date Instrumentation Amplifier Null Adjustment (<i>Option E02 only</i>)	Reference Level Accuracy Frequency Response
A17 Memory Card	None	None [†]
A20 HP-IB I/O (<i>Option 021</i>)	None	None
A21 RS-232 I/O (<i>Option 029</i>)	None	None
A25 Counter Lock	10 MHz Reference (Standard) Sampler Match Adjustment CAL FREQ Adjustment Routine CAL AMPTD Adjustment Routine	10 MHz Reference Accuracy (Standard Timebase) Frequency Readout Accuracy and Marker Count Accuracy Noise Sidebands System Related Sidebands Residual FM Spurious Response Residual Responses
<p>* These adjustments are not necessary if valid correction constants are recovered from the defective A16 assembly. See the "A16 Processor/Video Board Assembly" replacement procedure in Chapter 4 of the Service Manual.</p> <p>† Perform the examples from the HP 8594A/8594A Spectrum Analyzer Installation and Verification Manual that demonstrate the operation of this assembly.</p>		

**Table 6-2.
Adjustments and Tests for Replaced or Repaired Assemblies (continued)**

Replaced or Repaired Assembly	Related Adjustments and Adjustment Routines	Related Performance Verification Tests
A101 Fast Time Domain Sweeps (<i>Option 101</i>)	CAL FREQ Adjustment Routine CAL AMPTD Adjustment Routine	Fast Time Domain Sweeps (<i>Option 101</i>)
A102 AM/FM Speaker and TV Synch Trigger (<i>Option 102</i>)	CAL FREQ Adjustment Routine CAL AMPTD Adjustment Routine	None†
A103 Quasi Peak Detector and TV Synch Trigger (<i>Option 103</i>)	CAL FREQ Adjustment Routine CAL AMPTD Adjustment Routine	None†
A105 Time Gate and TV Synch Trigger (<i>Option 105</i>)	CAL FREQ Adjustment Routine CAL AMPTD Adjustment Routine	None†
† Perform the examples from the HP 8594A/8594A Spectrum Analyzer Installation and Verification Manual that demonstrate the operation of this assembly.		

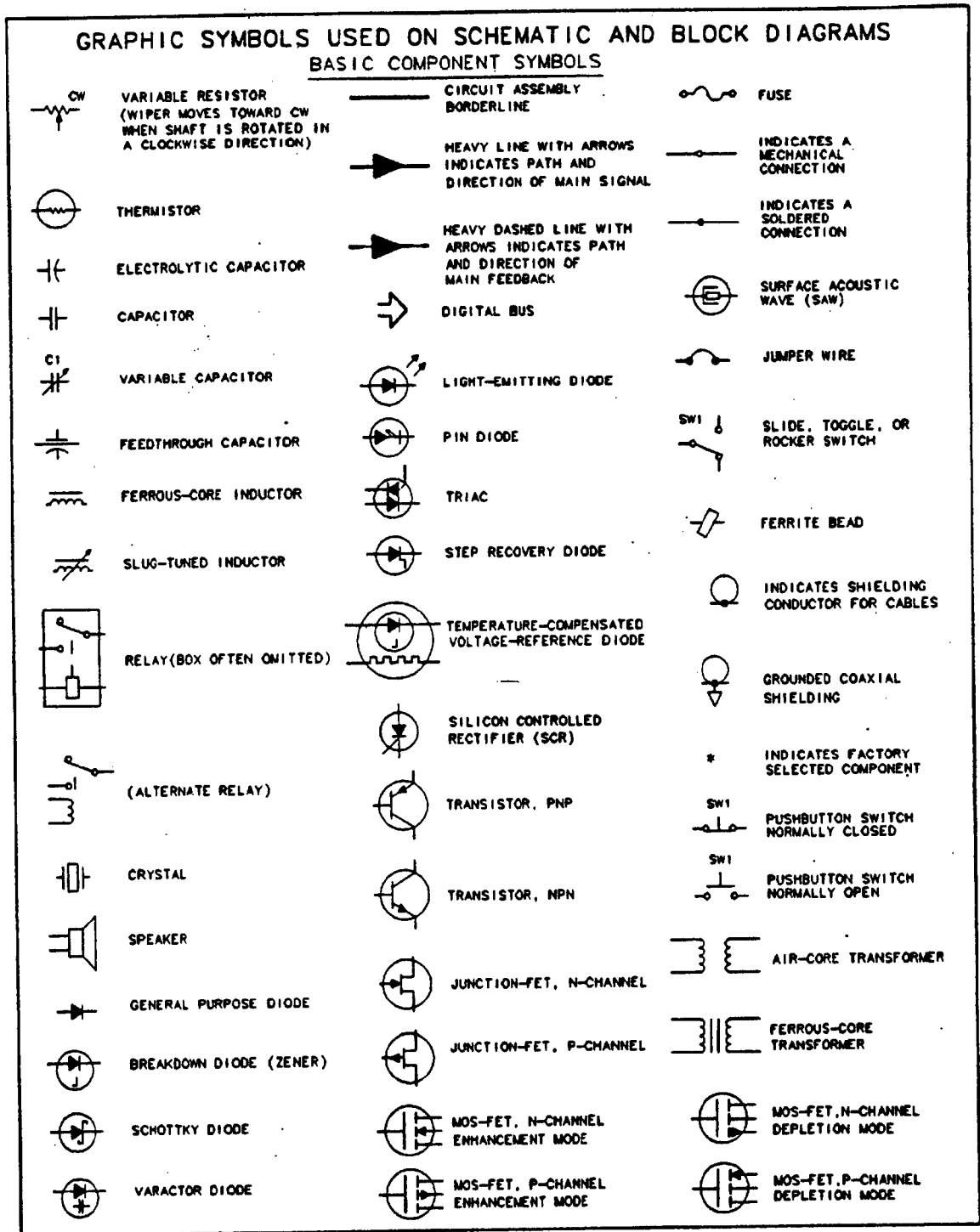

Figure 6-1. Graphics Symbols Used on Schematic and Block Diagrams (1 of 2)

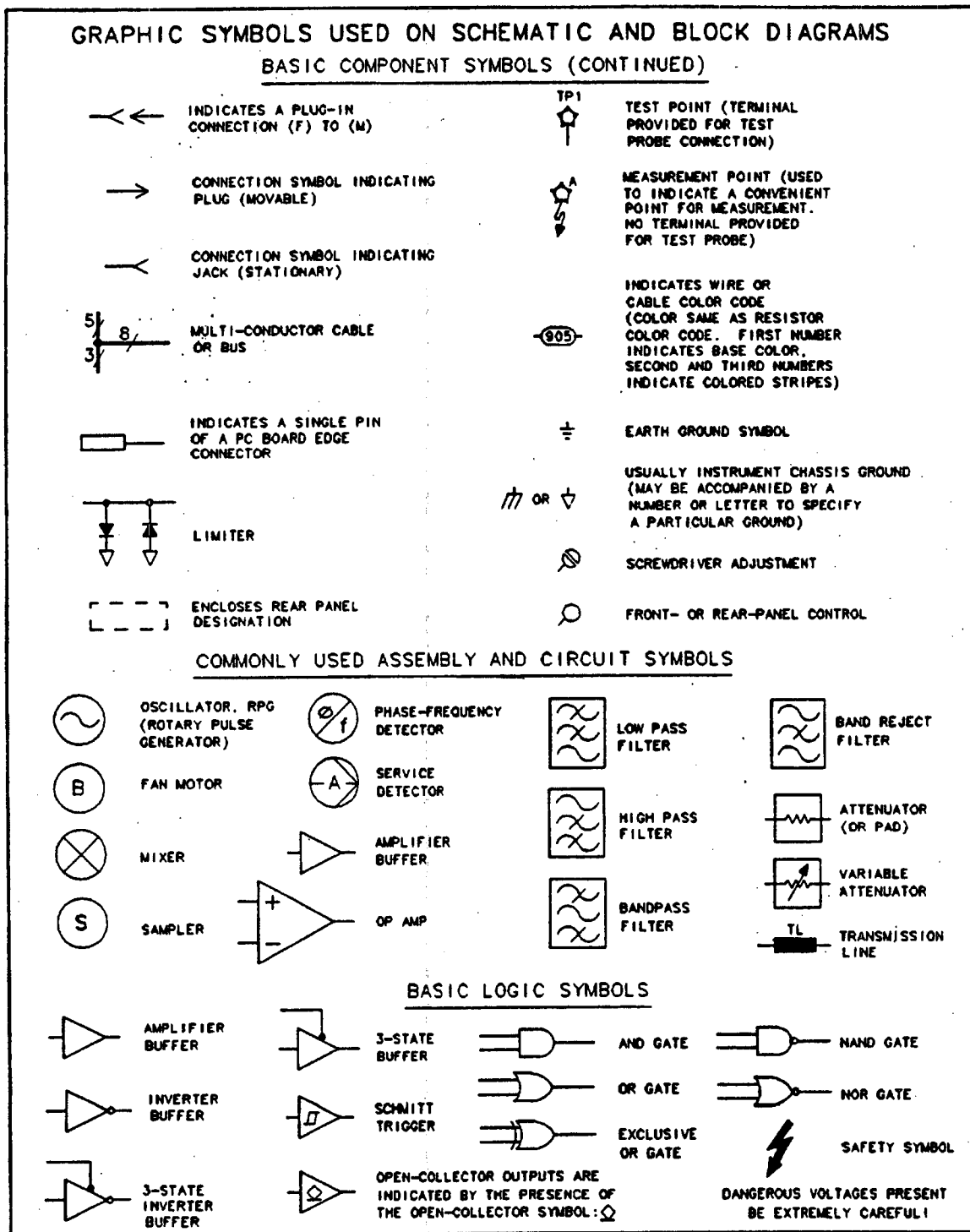

Figure 6-1. Graphics Symbols Used on Schematic and Block Diagrams (2 of 2)

RF and LO Section Overview

This section describes the operation of the A3 Front-End assembly and the A25 Counter Lock assembly. The related operation of the A7 Analog Interface assembly and the A9 Third Converter are also described. Each block of text describes an instrument assembly designated by its reference designator. Foldout 6-1, RF Section Overall Block Diagram, illustrates the assembly descriptions in this section.

The spectrum analyzer is a microprocessor-controlled swept receiver covering a frequency range of 9 kHz to 6.5 GHz. Frequency accuracy is enhanced by counter-locking the local oscillator to a 10 MHz frequency reference. The overall description briefly describes each of the major instrument assemblies.

RF Section Description

A3A5 Input Attenuator DC Block

The A3A5 Input Attenuator has a 70 dB range and is selectable from the front panel. When the spectrum analyzer is off, the attenuator is automatically set to 70 dB for protection from electrostatic discharge (ESD). **PRESET** or instrument power-on selects 10 dB attenuation and dc block. If **POWERON LAST** is selected, the spectrum analyzer is reset to the settings in use when the spectrum analyzer was turned off.

A3A2 Switched YTF

The A3A2 Switched YTF (SYTF) directs the output of the A3A5 attenuator to the A3A3 2.9 GHz Low-Pass Filter in low band (band 0) or to the A3A6 Dual Mixer in high band (band 1).

Continuous sweeps are possible from low band to high band.

When switching between bands, the A7 Analog Interface assembly switches the A3A2 output simultaneously with the PIN diode switches on the A3A6 Dual Mixer and the A3A4 Second Converter.

The YTF (built in to the A3A2 assembly) is a tracking preselector, with a bandwidth of approximately 25 MHz at 2.75 GHz. DACs on the A7 Analog Interface assembly control the adjustment of the YTF. The YTF Coarse DAC and Span DAC provide a coarse adjustment, and the YTF Fine DAC provides a fine adjustment. The YTF Fine DAC is also used for preselector peaking.

Note



Use of the **CAL YTF** routine ensures that the unpeaked frequency response is optimal at different operating temperatures. The routine sets the preselector defaults that are used by the **PRESEL DEFAULT** function.

Perform the routine whenever **PRESEL PEAK** has more than a 2 dB effect on signal amplitude while operating in a single band sweep.

The YTF closely tracks the tuned input frequency at any temperature and does not require preselector peaking to meet the unpeaked frequency response specification. The following must be done to ensure optimum unpeaked frequency response:

- Select **PRESEL DEFAULT** when preselector peaking is not required.

- Perform the **CAL YTF** self-calibration routine periodically. Refer to the *HP 8594A/8595A Installation and Verification Manual*.

A3A3 Low-Pass Filter

The A3A3 Low-Pass Filter has a cutoff frequency of 2.9 GHz. It decreases the level of any out-of-band responses.

A3A6 Dual-Band Mixer

The A3A6 Dual Band-Mixer contains two separate mixers: one for low band (band 0), and one for high band (band 1). A limiter is built into the low-band mixer to prevent damage from high peak-pulse-power signals. Refer to "Spectrum-Analyzer Input Protection" in Chapter 1 for maximum input level requirements.

The frequency of the desired YTO harmonic is always greater than the tuned input frequency. Refer to Table 6-3 for the relationship of tuned frequency to LO harmonic.

- In low band, the dual mixer produces a 3.9214 GHz 1st IF output that passes through FL1, a 4.4 GHz low-pass filter, to the A3A4 Second Converter.
- In high band, the mixer produces the 321.4 MHz IF that passes directly to the A3A4 assembly.

Table 6-3. Relationship of Input Frequency to LO Harmonic

Band Number	LO Harmonic (N)	Frequency Range
0	1	9 kHz to 2.9 GHz
1	1	2.75 GHz to 6.5 GHz

The A7 Analog Interface assembly controls a PIN diode switch in the A3A6 to direct the output of the 1st LO from the A3A10 Directional Coupler assembly to either the low-band or the high-band mixer.

DACs on the A7 assembly adjust the mixer bias for band 1. A DAC value for band 1 is stored in battery-backed RAM. Refer to the **MIXER BIAS DAC** and **CAL MIX** descriptions in Chapter 10 for more information.

A3A4 Second Converter

In low band, the A3A4 Second Converter mixes the 3.9214 GHz 1st IF with the 3.6 GHz 2nd LO to produce the 321.4 MHz 2nd IF. The 2nd IF signal then passes through a PIN diode switch in the second converter, to the A3A9 321.4 MHz Bandpass Filter, and the A9 Third Converter assembly.

The 3.6 GHz 2nd LO is generated by multiplying the 600 MHz reference from A9 by six. Cavity filters are used for the 1st IF bandpass filter and the second LO bandpass filter. The 2nd LO bandpass filters are necessary to remove unwanted harmonics of the 600 MHz driving signal.

In high band, the PIN diode switch in the A3A4 Second Converter passes the 321.4 MHz 1st IF directly from the A3A6 Dual Mixer, through the A3A9 321.4 MHz Bandpass Filter, to the A9 Third Converter.

A9 Third Converter

The A9 Third Converter performs five functions:

- Produces the 300 MHz CAL OUT signal. The CAL OUT signal is rich in harmonics; these are required for the CAL FREQ self-calibration routine.
- Provides the 600 MHz reference to the multiplier on the A3A4 assembly.
- Sends a 300 MHz signal to the A25 Counter Lock assembly. The A25 assembly locks the 300 MHz signal to the 10 MHz frequency reference.
- Converts the 321.4 MHz IF signal to the final 21.4 MHz IF signal.
 - The 321.4 MHz IF signal is first amplified and filtered by the 321.4 MHz bandpass filter.
 - The 600 MHz reference is divided to produce the 300 MHz 3rd LO. Refer to "LO Section Information" in Chapter 7 for information on the stability of the 600 MHz reference.
 - The filtered 321.4 MHz IF signal and the 300 MHz third LO mix at the third mixer, a double-balanced mixer, to produce the 21.4 MHz IF.
 - The 21.4 MHz IF passes through a 21.4 MHz bandpass filter, a buffer amplifier with a nominal 19 dB of gain, and a variable IF calibration amplifier. The variable amplifier has a gain range of -15 to +2 dB.
- Changes the amplitude of the 21.4 MHz IF signal to calibrate the instrument during the CAL AMPTD self-calibration routine.
 - The amplitude of the detected 21.4 MHz IF signal is measured on the A16 Processor/Video assembly.
 - The A7 Analog Interface assembly adjusts the gain of the IF calibration amplifier based on the A16 amplitude measurement.
 - The CAL AMPTD routine adjusts the output of the IF calibration amplifier for a displayed amplitude of -20 dBm at 300 MHz. The instrument is set for a reference level of -20 dBm and a center frequency of 300 MHz. (The calibration routine uses the CAL OUT signal.)

A3A1 Comb Generator

The A3A1 Comb Generator produces a 100 MHz signal with an amplitude of approximately +27 dBm when COMB GEN ON is selected. If COMB GEN OFF is selected, a 100 MHz signal remains, but it is lower in amplitude.

The A3A11 Step-Recovery Diode and the A3A12 3 dB Pad

When COMB GEN ON is selected, the 100 MHz comb generator signal drives the A3A11 Step Recovery Diode to produce 100 MHz comb teeth. The A3A12 3 dB Pad improves the output match of the A3A11.

The 100 MHz comb output is used by the CAL MXR and CAL YTF self-calibration routines.

LO Section Description

10 MHz Frequency Reference

The 10 MHz frequency reference is used to phase-lock the 600 MHz oscillator on the A9 Third Converter. There are two frequency references available for the HP 8595A Portable Spectrum Analyzer:

- The standard 10 MHz room temperature crystal oscillator (RTXO). The reference is located on the A25 Counter Lock assembly.
- The optional A22 Precision Frequency Reference (PFR), Option 004. The A22 is a 10 MHz oven-controlled crystal oscillator (OCXO).

The output from either frequency reference is sent to the rear-panel 10 MHz REF OUTPUT connector. The W16 cable that connects the RTXO to the rear panel is replaced by W17 when the OCXO is installed in the spectrum analyzer. A jumper on the rear panel connects the 10 MHz REF OUTPUT to the EXT REF IN connector.

If an external frequency reference is desired, the jumper is removed and the external reference connected to the EXT REF IN connector. EXT REF IN is connected to the reference PLL circuitry on A25 assembly. Refer to the *HP 8594A/8595A Installation and Verification Manual* for the power level required when using the EXT REF IN connector.

A25 Counter Lock

The A25 Counter Lock assembly improves the frequency stability of the spectrum analyzer by phase-locking the 600 MHz reference on the A9 assembly to the 10 MHz frequency reference and count-locking the center frequency of the LO.

In spans less than or equal to 10 MHz, the A25 assembly further improves LO stability and frequency accuracy by frequency-locking the LO sweep, using a frequency discriminator.

The 300 MHz CNTR LOCK OUT signal from A9 and the 10 MHz reference from the rear panel of the spectrum analyzer are fed to the reference PLL circuitry on the A25 Counter Lock assembly.

- The 300 MHz signal is divided by 40 to yield a 7.5 MHz reference signal for use by the frequency counter, discriminator, and sampling oscillator PLL.
- The 10 MHz reference and 7.5 MHz signal are divided and compared in a phase/frequency detector.
- The detector output tunes the 600 MHz reference via the VTO.TUNE line.

The sampling oscillator PLL on A25 can be tuned between 279 MHz and 298 MHz in 150 kHz steps. The output of the sampling oscillator PLL drives the A25A1 Sampler.

A25A1 Sampler

The A25A1 Sampler mixes the 1st LO with a harmonic of the sampling oscillator to produce the 76 MHz to 89 MHz sampler IF output. In the phase-locking process, the sampler IF is counted and the YTO tune DACs on the A7 Analog Interface assembly are adjusted until the actual sampler IF frequency is equal to the desired sampler IF. In YTO spans of 10 MHz or less, the sampler IF is also applied to a discriminator. The output of the discriminator (DISCRIM) fine-tunes the YTO precisely to the center frequency.

A3A7 YTO, A3A13 Isolator, and A3A10 Directional Coupler

The A3A7 YTO provides the 3.0 to 6.8214 GHz 1st LO. The YTO output passes through the A3A13 Isolator to the A3A10 Directional Coupler.

- The main-line output of A3A10 is used to drive the A3A6 Dual Band Mixer.
- The A3A10 couples the LO signal to drive the A25A1 Sampler. The coupled output power of the A3A10 is approximately -1 dBm before it is attenuated further by the AT1 10 dB Pad.

A7 Analog Interface

The A7 Analog Interface assembly receives digital control input on the IOB control lines from the A16 Processor/Video assembly, and produces analog control signals for most of the instrument functions. This section describes several of the control functions illustrated on Foldout 6-1.

- Provides control voltages for the Sweep Generator and Span Dividers:
 - The SWEEP RAMP output is 0 to +10 V.
 - The RAMP output is -10 V to +10 V for any span.
 - Two SPAN signals, MAIN SPAN and FM SPAN, are generated by attenuating the RAMP signal. The amplitude of the SPAN signals depends on the span setting selected.
 - The MAIN SPAN signal is used for LO spans greater than 10 MHz.
 - The FM SPAN signal is used for LO spans less than or equal to 10 MHz.
 - The MAIN SPAN and FM SPAN signals are fed to the YTO drivers to sweep the YTO frequency.
- Controls the center frequency of the YTO:
 - The YTO tune DACs in the A7 YTO driver circuitry determine the center frequency of the YTO.
 - For LO spans greater than 10 MHz, the MAIN SPAN signal is summed with the output of the YTO tune DAC in the YTO main coil driver.
 - For LO spans less than or equal to 10 MHz, the FM SPAN signal is summed with the A25 DISCRIM signal in the FM coil driver. The DISCRIM signal is used to lock the YTO precisely to the center frequency.
 - The control voltages produced using either SPAN signal are then converted to currents that drive the A3A7 YTO.

Instrument Settings for RF Power-Level Measurement

Ensure that the CAL OUT amplitude is within specification. (Refer to the Calibrator Amplitude Performance Test in the Installation, Verification, and Operation Manual.)

The power level ranges listed for measurements A through E in Table 6-4 apply under the following conditions:

Select the appropriate input signal for the desired frequency band:

Band 0 300 MHz at -20 dBm (CAL OUT signal)
 Band 1 5 GHz at 0 dBm

Set the spectrum analyzer to the following settings:

PRESET Wait for the spectrum analyzer to complete the instrument preset routine.

FREQUENCY same as input signal

SPAN 0 Hz

AMPLITUDE 0 dBm

ATTEN 10 dB

BW 3 MHz

SWEEP 20 ms

SWEPTIME 20 ms

Table 6-4. Power Levels at Measurement Points

Measurement Point	Measurement Frequency	Power Level Range *	
		Band 0	Band 1
A	Same as input frequency	-30 to -33 dBm	—
B	Same as input frequency	—	-14 to -19 dBm
C	321.4 MHz	—	10 to 16 dB below B †
D	3.9214 GHz	8 to 12 dB below A †	—
E	321.4 MHz	5 to 11 dB below D †	1 to 6 dB below C †

* A frequency-selective measuring device, such as another spectrum analyzer, is recommended for making these measurements. Broadband measuring devices, such as power meters, will give erroneous results due to the presence of other, higher-amplitude signals.

† The power-level range is relative to the actual measurement taken at the measurement point indicated.

IF, Video, and Instrument Control Overview

This section describes the operation of the IF section assemblies and the A16 Processor/Video assembly. The related operation of the A7 Analog Interface assembly and the A8 Power Supply are also described. The IF/Control Overall Block Diagram, Foldout 6-2, illustrates the assembly descriptions in this section.

The A15 Motherboard pin designation of related assemblies along the IF signal path are detailed on Foldout 6-2. Refer to "A15 Motherboard Assembly" in Chapter 8 for more information about the connection of instrument assemblies to the motherboard.

IF Section Assembly Descriptions

A11 Bandwidth Filter

The A11 Bandwidth Filter assembly contains two synchronously tuned LC filter poles and two synchronously tuned crystal filter poles. Buffer amplifiers provide isolation for each filter pole.

Eight IF bandwidths, from 1 kHz to 3 MHz, can be selected in a 1,3,10 sequence. The desired IF passband, or resolution bandwidth, is produced by either a four-pole LC bandpass filter or a four-pole crystal bandpass filter. The A13 Bandwidth Filter assembly is identical to the A11 assembly and provides two of the four filter poles. The LC bandpass filters provide the 100 kHz to 3 MHz bandwidths, and the crystal bandpass filters provide the 1 kHz to 30 kHz bandwidths.

When a bandwidth is selected, the A7 Analog Interface assembly interprets the A16 Processor/Video assembly commands and produces the corresponding bandwidth control currents. The A7 assembly produces a bias voltage (BW5) to select LC or crystal mode, and a bandwidth control current for either the LC filters (BW7) or the crystal filters (BW6). Bandwidth errors are corrected by the **CAL AMPTD** self-calibration routine. Refer to Chapter 10 for a description of **CAL AMPTD**.

The resolution bandwidths are normally coupled to the frequency span of the spectrum analyzer for an optimum ratio of span to resolution bandwidth. Sweep time is also coupled to both resolution bandwidth and span for optimum amplitude response. The resolution bandwidth, sweep time, and span can be set independently.

A12 Amplitude Control

The A12 Amplitude Control assembly provides gain or attenuation in eight stages: three step-gain amplifiers and five step attenuators. All stages, except the 10 dB step gain, provide full gain or attenuation when turned on and unity gain when turned off. The 10 dB step gain has a gain of 15 dB when on and a gain of 5 dB when off.

When the reference level is changed, the A7 Analog Interface assembly interprets the A16 Processor/Video assembly commands and produces the appropriate combination of gain and attenuation control voltages in 1 dB increments. Reference-level resolution of less than 1 dB is produced by mathematically offsetting the digitized video signal on the A16 Processor/Video assembly.

A12 step-gain errors are corrected by correction factors produced by the **CAL AMPTD** self-calibration routine. Each correction factor is an offset of the digitized video signal and is stored in nonvolatile memory on the A16 assembly.

A12 step-attenuator errors are corrected by correction constants that are characterized values initially installed at the factory. The corrected calibration attenuators provide the amplitude reference used by **CAL AMPTD** self-calibration routine.

A13 Bandwidth Filter

The A13 Bandwidth Filter assembly is identical to the A11 assembly. Refer to the A11 assembly description in this section.

After leaving the A13 assembly, the 21.4 MHz IF signal branches on the A15 Motherboard:

- One branch passes directly to the A14 Log Amplifier assembly.
- A buffer amplifier on the A15 Motherboard attenuates the IF signal by 20 dB and distributes it to the card-cage assemblies (**AUX_IF**), the rear panel **AUX IF OUTPUT** connector (**AUX_IF_BP**), and the A25 Counter Lock assembly (**COUNT_IF**). The **COUNT_IF** signal is used by the A25 assembly to count the actual IF frequency when **MKR CNT ON** is selected.
- Another buffer amplifier on the A15 assembly sends the IF signal (**AUX_IF**) to assemblies installed in the card cage.

A14 Log Amplifier

The A14 Log Amplifier assembly provides the following functions:

- **Log Mode.** The input signal is logarithmically displayed due to the sequential response of seven log amplifier stages.
 - The log amplifier stages have an overall range of 70 dB. This allows a greater range of signal amplitudes to be simultaneously displayed.
 - All seven amplifier stages are at maximum gain for low input signal levels.
 - As the signal level increases, the gain of the each 10 dB amplifier is reduced in sequence, with the last stage dropping to unity gain first.
 - The vertical display axis is calibrated in dBm (relative to a milliwatt) rather than volts.
- **Linear Mode.** The seven log amplifier stages are biased to operate as linear amplifiers. Linear gains from 0 dB to 40 dB can be selected.
- **The Video Detector.** The detector is a half-wave rectifier and filter. The video signal (**VIDEO_IF**) has a 0 to 2 volt output that is proportional to the signal level.
- **T/C Supply.** A temperature-compensated -8 V reference supply (-8 VT).
 - Maintains amplitude stability of the log stages over temperature.
 - Maintains linear step-gain accuracy by providing a stable voltage source for the linear step-gain control lines that originate on the A7 assembly.

A16 Processor/Video

The A16 assembly coordinates the operation of all instrument assemblies to perform all spectrum analyzer functions. This section briefly describes the major instrument functions provided directly by the A16 Processor/Video assembly.

- Selection of the input signal for the ADC. The input MUX selects one of the following:

- An analog signal from assemblies installed in the card cage.
- The detected 21.4 MHz IF signal (VIDEO_IF).
- A +2 V reference used for ADC calibration of the graticule at top screen.
- An analog ground (ACOM) reference used for ADC calibration of graticule at bottom screen.
- Final processing of the detected 21.4 MHz IF signal before the video signal is converted by the ADC for further digital processing by the central processing unit (CPU).
 - Video bandwidths from 30 Hz to 3 MHz are available in a 1, 3, 10 sequence.
 - The ADC input MUX selects the positive-peak detector, or bypasses the positive-peak detector, and selects the sample detector. In sample mode, the video signal passes directly to the ADC from the video bandwidth circuitry.
 - The MUX can also select the processed video signal from an assembly in the card cage.
- Mathematical offset of the digitized video signal for greater reference-level resolution and instrument calibration accuracy.
- Digital control of instrument assemblies directly over the IO bus.
- Analog control of instrument assemblies via the A7 Analog Interface assembly.
- Nonvolatile RAM memory-storage of DLP software, instrument calibration data, and error correction data. Refer to Chapter 10 for more information about instrument calibration and error correction.
- Processing and integration of trace and text information for output to the A2 Display assembly. The digitized video signal is merged by the CPU with other trace information. The trace information is then combined with text information for input to the display drive circuitry.
- Generation of the A2 display drive signals. The digital display input is converted back into analog voltages by the A16 display drive-circuitry and sent to the A2 assembly. The display signal is also sent to MONITOR OUTPUT on the rear panel.

A7 Analog Interface

The A7 Analog Interface assembly converts the digital commands from the A16 assembly to analog control signals for the following assemblies shown on Foldout 6-2:

- DAC control of the A11/A13 Bandwidth Filter assemblies. Refer to "A7 Analog Interface Assembly" in Chapter 9 and "IF Section Information" in Chapter 8 for more information about bandwidth switching.
 - LC to crystal mode switching. BW5 controls switching between crystal and LC bandwidth filter modes.
 - Bandwidth control. The A7 bandwidth control DACs supply two control lines to drive the PIN diodes on the A11 and A13 assemblies. Companding DACs are used because their nonlinear output compensates for the nonlinear resistance-versus-current of the PIN diodes they control.
 - BW6 control line. Controls the crystal bandwidths from 30 kHz to 1 kHz. More DAC current produces a narrower bandwidth in crystal mode.

- BW7 control line. Controls the LC bandwidths from 5 MHz to 100 kHz. In LC mode more DAC current produces a wider bandwidth.
- A12 Amplitude Control assembly. When the reference level is changed, the A7 assembly switches the calibration attenuators and 10 dB step gains on the A12 assembly to change the displayed signal position. Refer to "IF Section Information" in Chapter 8 for more information about switching for the calibration attenuator, the 10 dB step gains, and the log/linear switch.
 - Calibration attenuators. A TTL high on selected A7 control lines activates a combination of attenuator steps. The 1, 2, 4, and 8 dB step attenuators are combined to provide attenuation in 1 dB increments. Currently, the 16 dB attenuator is not used.
 - 10 dB step gains. Temperature-compensated control voltages activate a combination of the three A12 step-gain stages. Step gains are produced in 10 dB increments over a 50 dB range.

Step gain errors are corrected by the **CAL AMPTD** self-calibration routine. Refer to Chapter 10 for a description of **CAL AMPTD**.

- A14 Log Amplifier assembly. The A7 assembly controls two functions on the A14 assembly:
 - Log/linear mode switching. A temperature-compensated control bias voltage switches the seven A14 amplifier stages to function as either linear amplifiers or logging amplifiers.
 - 10 dB linear step gains. In linear mode, three temperature-compensated control lines bias four of the seven linear amplifiers to provide step gains in 10 dB increments over a 40 dB range. Two amplifiers are switched by one control line to provide the 20 dB step-gain stage.

Linear step-gain errors are corrected by the **CAL AMPTD** self-calibration routine. Refer to Chapter 10 for a description of **CAL AMPTD**.

A8 Power Supply

The A8 Power Supply is a switching power supply that plugs into a connector on the A15 Motherboard. It is not repairable to the component level.

When the line switch is on, the power supply receives the low-power-on (LPWRON) signal and produces the following:

- +12 V for the B1 fan.
- The +5 V, +15 V, -15 V, and +12 V supply voltages.
- A line-trigger signal (LINE.TRIG) at the power-line frequency.
- The high-power-on (HPWRUP) signal used to coordinate the start-up of the A7 and A16 assemblies.

IF Power-Level Measurement

The following measurement procedures are used for troubleshooting along the 21.4 MHz IF signal path from the A9 Third Converter assembly, through the IF section, to output of the A14 Log Amplifier assembly.

To calibrate the reference level of the analyzer, the **CAL AMPTD** self-calibration routine adjusts the gain of the 21.4 MHz IF variable amplifier on the A9 assembly and mathematically offsets the digitized video signal on the A16 Processor/Video assembly. Due to component variations it is unlikely that any two spectrum analyzers will have the same 21.4 MHz IF signal level for the same instrument settings. Furthermore, a defective spectrum analyzer may produce misleading IF signal levels if the **CAL AMPTD** routine has been run.

An IF test board is used in the following procedures to simplify troubleshooting. The test board is used to isolate the RF section from the IF section and allows the testing of individual IF assemblies. Refer to Table 1-5, Special Service Tools, for the part number of the IF test board.

Instrument Settings for IF Power-Level Measurement

The power levels provided with the measurement procedures in this section are accurate when the following steps are followed.

1. Ensure that the CAL OUT amplitude is within specification. Refer to the Calibrator Amplitude Performance Test in the *HP 8594A/8595A Installation and Verification Manual*.
2. Connect the CAL OUT signal to the RF input using the CAL cable.
3. Set the spectrum analyzer to the following settings:

PRESET Wait for the spectrum analyzer to complete the instrument preset routine.

FREQUENCY 300 MHz

SPAN 0 Hz

Typical Gains for the IF Assemblies

The overall gain of individual assemblies in the IF section are listed below. The gain level provided for the A12 assembly is correct only when the spectrum analyzer settings provided in step three, above.

- The A11 Bandwidth Filter assembly produces 10 dB of gain.
- The A12 Amplitude Control assembly produces -5 dB of gain.
- The A13 Bandwidth Filter assembly produces 10 dB of gain.
- A +10 dBm signal at the input of the A14 Log Amplifier assembly produces a 2 V signal (VIDEO IF) that is equivalent to a top-screen display.

Refer to "IF Section Information" in Chapter 8 for the changes in gain output when the instrument settings are changed from the settings used in this section.

Measurement of the IF Signal from the A9 Third Converter

Measure the 21.4 MHz IF output from the A9 assembly with the following procedure. Refer to Foldout 6-2, IF/Control Overall Block Diagram, while performing this procedure.

1. Remove the A11 Bandwidth Filter assembly.
2. Insert the IF test board in the A11 assembly slot.
3. Measure the 21.4 MHz IF output at J1 on the IF test board using an active probe, with a spectrum analyzer attached. (Use of a 50 Ω spectrum analyzer will cause erroneous power-level measurements.)
4. The test limit for the 21.4 MHz IF signal is $-25 \text{ dBm} \pm 2 \text{ dB}$. The test board receives the signal at measurement point A on the block diagram.

Note



The variable IF amplifier at the output of the A9 assembly has a gain range of -15 to $+2 \text{ dB}$. This level is dependent on the output from the reference level DAC, located on the A7 Analog Interface assembly, that is adjusted during the **CAL AMPTD** self-calibration routine.

Signal Injection at the Output of the A11 Bandwidth Filter Assembly

Inject a 21.4 MHz signal at the output of the A11 Bandwidth Filter assembly with the following procedure. Refer to Foldout 6-2 while performing this procedure.

1. Remove the A11 Bandwidth Filter assembly.
2. Insert the IF test board in the A11 assembly slot.
3. Connect a synthesizer/level-generator to the J2 input connector on the IF test board. The test board injects the signal at A15J8 pin 22.
4. Set the signal source for 21.4 MHz at $+5 \text{ dBm}$. This signal level provides $+10 \text{ dBm}$ at the input to the A14 Log Amplifier assembly and simulates a top-screen signal.
5. Check for the following nominal signal outputs.

- A -10 dBm at the AUX IF OUTPUT connector on the rear panel. Refer to measurement point C on Foldout 6-2.

Use an active probe to make the measurement. If a 50 Ω spectrum analyzer is used, an additional 6 dB drop in signal level results. (The AUX IF OUTPUT has a 50 Ω output impedance.)

- One volt at the AUX VIDEO OUTPUT connector on the rear panel (measurement point B). A voltage divider on the A15 Motherboard reduces the uncorrected 2 V video signal (AUX VIDEO) to a 1 V output.
- A signal at the top graticule line and a marker reading of approximately 0 dBm.

Note



Use **CORRECT ON OFF** to observe the magnitude of video offsets that the A16 assembly is currently using to correct the signal position at top-screen. Refer to Chapter 10 for more information about **CORRECT ON OFF**.

Signal Injection at the Output of the A13 Bandwidth Filter Assembly

Inject a 21.4 MHz signal at the output of the A13 Bandwidth Filter assembly with the following procedure. Refer to Foldout 6-2 while performing this procedure.

1. Remove the A13 Bandwidth Filter assembly.
2. Insert the IF test board in the A13 assembly slot.
3. Connect a synthesizer/level-generator to the J2 input connector on the IF test board. The test board injects the signal at A15J11 pin 22.
4. Set the signal source for 21.4 MHz at +13 dBm. This signal level provides +10 dBm at the input to the A14 Log Amplifier assembly and simulates a signal at top-screen. The output impedance of the IF test board interacts with circuitry on the A15 assembly to cause a 3 dB signal loss.
5. Check for the following nominal signal outputs.

- A -10 dBm at the AUX IF OUTPUT connector on the rear panel. Refer to measurement point C on Foldout 6-2.

Use an active probe to make the measurement. If a 50 Ω spectrum analyzer is used, an additional 6 dB drop in signal level results. (The AUX IF OUTPUT has a 50 Ω output impedance.)

- One Volt at the AUX VIDEO OUTPUT connector on the rear panel (Measurement Point B). A voltage divider on the A15 Motherboard reduces the uncorrected 2 V video signal (AUX_VIDEO) to a 1 V output.
- A signal at the top graticule line and a marker reading of approximately 0 dBm.

Note



Use **CORRECT ON OFF** to observe the magnitude of video offsets that the A16 assembly is currently using to correct the signal position at top-screen. Refer to Chapter 10 for more information about **CORRECT ON OFF**.

Problems at Instrument Power-Up

Caution



Immediately unplug the spectrum analyzer from the ac power line if the unit shows any of the following symptoms:

- Smoke, arcing, or unusual noise from inside the unit.
- No response of any kind when unit is plugged into ac power mains and turned on.
- The spectrum analyzer's ac power fuse blows.
- A circuit breaker or fuse on the main ac power line opens.

These potentially serious faults must be corrected before proceeding. Refer to "Troubleshooting an Inoperative Spectrum Analyzer."

Symptoms at Power-Up

Note



Instruments equipped with the AM/FM Speaker and TV Sync Trigger, Option 102, normally emit noise from the speaker at power-up. Adjust the volume control as desired.

Symptoms that can occur when the instrument is first powered up are described here, along with the location of related troubleshooting information. Refer to Table 6-5 for an overview of symptoms at power-up and their possible cause.

- The spectrum analyzer is completely dead and there is no obvious cause of the failure. Refer to “Troubleshooting an Inoperative Spectrum Analyzer.”
- The A2 Display is blank, yet the instrument fan is running and the green LED above the LINE switch is on. Refer to “Blank A2 Display.”
- A firmware-controlled instrument routine fails. Refer to Chapter 10 and Chapter 11 for troubleshooting information about the following failures:
 - Initial Power-Up routine.
 - Instrument Preset routine.
 - A self-calibration routine.
 - A confidence test.
- The A2 Display is distorted. Refer to “A2 Display Troubleshooting.”
- Refer to “Symptoms of a Dead Battery” if the A2 Display has either of the following symptoms:
 - A random display periodically flashes on-screen.
 - An empty rectangle first appears, followed by the message SYNTAX EMPTY. Approximately 8 seconds later the instrument performs an instrument preset and the error message FAIL: 0330 0000000000 is displayed.
- There is no displayed signal or the signal level is abnormal. Refer to “Locating an RF/LO/IF or Video Problem.”

Table 6-5. Instrument Failure Symptoms at Power-On

Line LED	A8 LED -15 V	A8 LED +15 V	A8 LED +5.2 V	A8 LED +12 V	A16 LEDs DS1-DS16	B1 Fan	A2 Display	Possible Cause
ON	ON	ON	ON	ON	M	ON	ON	Normal Operation *
OFF	ON	ON	ON	ON	M	ON	ON	W1 wiring to Line LED, or Line LED
OFF	OFF	OFF	OFF	OFF	OFF	OFF	OFF	Line fuse, A8 primary circuit failure
ON	M	M	M	M	X	M	X	A8 primary overload
ON	OFF	ON	ON	ON	X	ON	X	-15 V supply failure
ON	OFF	M	M	M	X	M	X	-15 V supply overload
ON	ON	OFF	ON	ON	X	ON	X	+15 V supply failure
ON	M	OFF	M	M	X	M	X	+15 V supply overload
ON	M	M	OFF	M	X	M	X	+5.2 V supply failure or supply overload
ON	ON	ON	ON	OFF	X	OFF	OFF	+12 V supply failure
ON	M	M	M	OFF	X	OFF	OFF	+12 V supply overload
ON	ON	ON	ON	ON	M	OFF	ON	Fan failure or open along +12 V supply line to fan
ON	ON	ON	ON	ON	OFF	ON	OFF	No HPWRUP signal
ON	ON	ON	ON	ON	ON	ON	X	A16 assembly failure
ON	ON	ON	ON	ON	M	ON	OFF	Display failure, intensity-control failure, or A16 memory failure
ON	ON	ON	ON	ON	M	ON	M	Intensity control failure, or A16 memory failure

M = LED or assembly is momentarily on, then goes off.
X = Status of LED or assembly does not matter.

* DS13 remains on after **PRESET**.

Troubleshooting an Inoperative Spectrum Analyzer

When a spectrum analyzer appears to be dead there is often little evidence that points directly to the cause. This section covers typical failure modes for the A2 Display, the A8 Power Supply, the A16 Processor/Video assembly, and related assemblies.

Additional troubleshooting details for specific assemblies are available in the following areas of this manual:

- Foldout 6-2, IF/Control Overall Block Diagram.
- "A15 Motherboard Assembly" in Chapter 8.
- Individual assembly descriptions.
- The adjustment procedures in Chapter 2.
- The component-level information packets (CLIPs) located in the *HP 8590 Series Component-Level Information* binder.

"A15 Motherboard Assembly" in Chapter 8 provides detailed information about the instrument power-up signals and the power-supply distribution network. Refer to this section when tracing signals or supply voltages throughout the instrument.

Check Instrument Setup

Before troubleshooting the instrument, ensure that it has been set up correctly.

- Check that the voltage-selector switch on the rear of the A8 Power Supply is correct for the ac power line in use.
- Check that the ac line-power voltage is present and that the instrument line cord is in good condition.
- Check the line fuse. If it has blown, perhaps a nonstandard fuse with too low a current rating was installed.

Caution



If the fuse must be replaced, make sure that the replacement fuse is specified for the line voltage in use. Failure to use the proper fuse specified for the HP 8595A spectrum analyzer can cause substantial instrument damage, and is a serious fire hazard.

Instrument Failure Symptoms

If the instrument was set up correctly and still does not function, look for troubleshooting information related to the observed failure symptoms, in the following sections:

- "The Line Fuse Has Blown." A line fuse of the correct rating has blown.
- "The Fan Is Not Operating." The fan is not running, yet the rest of the instrument is operating normally.
- "The A8 Power Supply LEDs Are Off." One or more of the LEDs on the A8 Power Supply is not on.
- "A16 Processor/Video Assembly Failure Symptoms." Failure symptoms indicate that the A16 assembly is the likely source of the problem.

- "Blank A2 Display." The display is blank but there are no failure symptoms from the rest of the instrument.

The Line Fuse Has Blown

If the instrument was set up correctly, and the line fuse still blows, check the operation of the power supply after removing it from the instrument. The A8 assembly is a switching power-supply and does not operate normally without a load on the dc power-supply outputs. Without an output load, the dc output voltages will not be within specification.

Caution

After removing the A8 Power Supply from the instrument, do not operate the power supply without a load on the dc supplies for more than 1 minute.

After removing the power supply from the instrument, use the following procedure to check that the power supply will power up.

1. Remove the A8 Power Supply from the instrument. Refer to the A8 Power Supply removal procedure in Chapter 3.
2. Replace the line fuse.
3. Connect line-power cord to the power supply.
4. Simulate the low-power-on (LPWRON) signal by shorting pin 19 on A8J1 to the A8 chassis ground. The power supply is functioning if all the A8 LEDs come on. It is normal for the LEDs on some power supplies to come on momentarily and then stay off.
5. If the A8 LEDs do not come on, disconnect the line power, and check the line fuse.
 - If the line fuse has blown again, the power supply is defective. The A8 assembly is not field-repairable; refer to Chapter 4 for ordering instructions.
 - If the fuse does not blow, suspect a short somewhere in the dc supply distribution network. Refer to "A15 Motherboard Assembly" in Chapter 8 for the A15 connector-pin designation of each assembly supplied by the power supply. Note the components on the A15 Motherboard that are attached to the dc power supplies.
6. After detecting a short, or low resistance, within one of the dc supply networks, remove each related assembly, one at a time, until the defective assembly is found.
 - If a short is detected on a trace from the A15 Motherboard to the A16 Processor/Video assembly, remove the A15 Motherboard from the instrument and check it separately.

The Fan Is Not Operating

Caution

The A8 Power Supply will be extremely hot if the instrument has been operating without the fan running. Allow the instrument to cool down before troubleshooting.

The B1 Fan receives +12 V dc from the A8 Power Supply after the power supply receives the start-up signal, low-power-on (LPWRON). First check the +12 V dc supply to the fan at the Rear Frame.

1. Disconnect the line-power cord from the spectrum analyzer.
2. Look through the fan grill. If the cables routed near the fan are jammed in the fan, remove the fan from the rear frame, reroute the cables, and remount the fan.
3. Remove the fan from the rear frame and disconnect its wiring connector from A15J19.
4. Reconnect line power to the spectrum analyzer and turn it on.
5. Refer to "A15 Motherboard Assembly" in Chapter 8 for the pin identification of the fan-supply connector, A15J19, and the A8 Power-Supply connector, A8J1.
6. Check that pin 2 on A15J19 is connected to digital common-ground (DCOM). If the ground connection is open, suspect the A15 Motherboard.
7. Check pin 1 on A15J19 for +12 V dc.
8. If the +12 V dc is absent, do the following:
 - Disconnect the spectrum analyzer from the line power.
 - Remove the A8 Power Supply.
 - Check the continuity of the A15 Motherboard from pin 1 on A15J19 to pin 8 on A15J13.
 - If the continuity of the motherboard is correct, suspect a bad connection on the D Sub connector (between pin 8 on A15J13 and pin 8 on A8J1) or a defective power supply.

The power supply is an original equipment manufacturer (OEM) assembly purchased by Hewlett-Packard from an outside vendor. It is not field-repairable, and must be replaced as an assembly. Refer to Chapter 4 for ordering instructions.

•A8 Power Supply LEDs Are Off

Caution



After removing the A8 Power Supply from the instrument, *do not* operate the power supply without a load on the dc supplies for more than 1 minute.

If All the A8 LEDs are Off

If all the power-supply LEDs remain off, the low-power-on (LPWRON) control line must be checked from the front-panel line switch, through the A16 Processor/Video assembly and A15 Motherboard, to the A8 Power Supply.

1. Disconnect the spectrum analyzer line-power cord, remove the instrument cover, and turn the instrument so its bottom side faces up.
2. Check that the line switch provides the correct LPWRON signal at pin 2 on A16J9.
 - LPWRON becomes TTL low when the line switch is on. The closed switch connects A16J9 pin 2 to the digital common-ground (DCOM) through the W1 wiring harness.
 - LPWRON is pulled TTL high by the power supply when the line switch is in STANDBY.
3. Remove the A8 Power Supply. Refer to the A8 Power Supply removal procedure in Chapter 3.

Note

The A8 assembly is a switching power supply and does not operate normally without a load on the dc power supply outputs. Without an output load, the dc output voltages will not be within specification.

4. Plug the line-power cord into the supply.
5. Simulate the LPWRON signal by shorting A8J1 pin 19 to the power-supply case using a jumper wire. If the power-supply LEDs do not come on, the power supply is defective. It is normal for the LEDs on some power supplies to come on momentarily and then stay off.
6. Check the continuity of the LPWRON signal trace from pin 2 on A16J9 to pin 19 on A15J13. Refer to Figure 6-2 for the numbering of the A15J13 connector-pins.

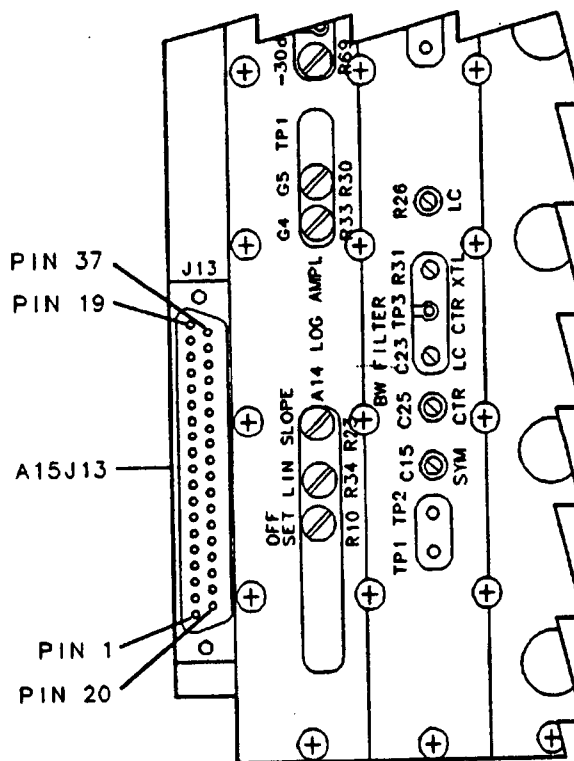

Figure 6-2. A15J13 Connector-Pin Designation

7. Refer to "A15 Motherboard Assembly" in Chapter 8 for the connector-pin designations of the A16 and A15 assemblies.
8. If the LPWRON signal path from the previous step is correct, suspect a bad connection on the D sub-connector (between pin 19 on A15J13 and pin 19 on A8J1).

The power supply is (OEM) assembly purchased by Hewlett-Packard from an outside vendor. It is not field-repairable, and must be replaced as an assembly. Refer to Chapter 4 for ordering instructions.

If Individual A8 LEDs are Off

If one or more of the A8 Power Supply LEDs remain off, determine whether the power supply is defective or circuitry on the dc power-supply distribution network is loading the supply down.

1. Remove the power supply from the instrument. Refer to the A8 Power Supply removal procedure in Chapter 3.
2. Plug the line-power cord into the supply.
3. Simulate the LPWRON signal by shorting pin 19 on A8J1 to the power-supply case using a jumper wire. If the power supply LEDs do not come on, the power supply is defective. It is normal for the LEDs on some power supplies to come on momentarily and then stay off.
4. Replace the power supply in the instrument.
5. Refer to "A15 Motherboard Assembly" in Chapter 8 to identify all the assemblies that are connected to the inoperative dc power supply.
6. Remove each related assembly, one at a time, until the defective assembly is found.
7. Refer to "A15 Motherboard Assembly" for the A15 connector-pin designation of each assembly connected to the supply.
 - If the problem remains after removing all related assemblies, suspect the A15 Motherboard assembly. It contains components that are attached to the dc power supplies. Refer to Figure 8-3 in the "A15 Motherboard Assembly."
 - If a short is detected on a trace from the A15 Motherboard to the A16 Processor/Video assembly, remove the A15 Motherboard from the instrument and check it separately.

A16 Processor/Video Assembly Failure Symptoms

If all the A8 Power-Supply LEDs are on, check the dc power-supply voltages on the A16 Processor/Video assembly. Check each voltage at the A16 assembly test points, TP401 through TP404. Refer to Foldout 6-2, for the dc-voltage assignment of each test point.

If a dc voltage is missing, suspect an open connection in the dc power-supply distribution network. Refer to "A15 Motherboard Assembly" in Chapter 8 for the connector-pin designation of each assembly connected to the missing dc voltage supply.

If all the dc voltages are correct at the A16 assembly, refer to "A16 Memory Reset" in Chapter 9.

Blank A2 Display

Use this section when the A8 Power Supply is functioning but there is no display on the A2 Display assembly. Check the following conditions before proceeding with the A2 Display troubleshooting procedures.

1. Plug the instrument into an ac power-line outlet and depress the **LINE** switch. Check that the B1 Fan is running and the green LED above the **LINE** switch is on. If they are not operating, refer to the appropriate section of "Troubleshooting an Inoperative Spectrum Analyzer."

Note

If an external monitor is available, attach it to the MONITOR OUTPUT on the rear frame. Adjust the horizontal hold on the external monitor. If a normal instrument display is present, the display failure is limited to the A2 Display and its related circuitry. Refer to the *HP 8594A/8595A Installation and Verification Manual* for a list of the available external monitors.

2. Disconnect the ac line power and remove the instrument cover. Refer to the instrument cover removal procedure in Chapter 3.
-

Note

The A8 Power Supply draws current whenever ac line power is applied, even when the LINE switch is in the STANDBY position. However, no voltages are distributed outside the A8 assembly when the LINE switch is in the STANDBY position, except for a TTL high on LPWRON.

3. Plug the spectrum analyzer into the ac line power and set the LINE switch to ON.
4. Check the four LEDs on the A8 Power Supply assembly. If they are not on, refer to the beginning of "Troubleshooting an Inoperative Spectrum Analyzer."
5. Check the dc power supplies on the A16 Processor/Video assembly. If an adjustment is required, refer to the power-supply adjustment procedure in Chapter 2. If there is a failure, refer to the beginning of "Troubleshooting an Inoperative Spectrum Analyzer."

A2 Display Troubleshooting

This section covers troubleshooting of the A2 Display and its related circuitry. Refer to the display overview provided in the A1 Front-Frame block on Foldout 6-2.

If the Display has an Intensity Problem

Caution

The A1R1 potentiometer leads are easily broken. Do not twist the W3 wire harness where it attaches to A1R1.

1. Disconnect W3 from the A1R1 intensity control potentiometer on the front frame.
2. Check the continuity and resistance range (0 to 100 k Ω) of the inner potentiometer on A1R1.
3. Reconnect W3 to A1R1.

Check the A16 Display-Drive Circuitry

Perform the following steps to check output of the drive circuitry from the A16 Processor/Video assembly to the A2 Display.

1. Position the spectrum analyzer with the bottom side facing up.
-

Caution

Do not short any two of the A16J8 pins together. Damage to the spectrum analyzer may result.

2. Disconnect the W2 wire harness.

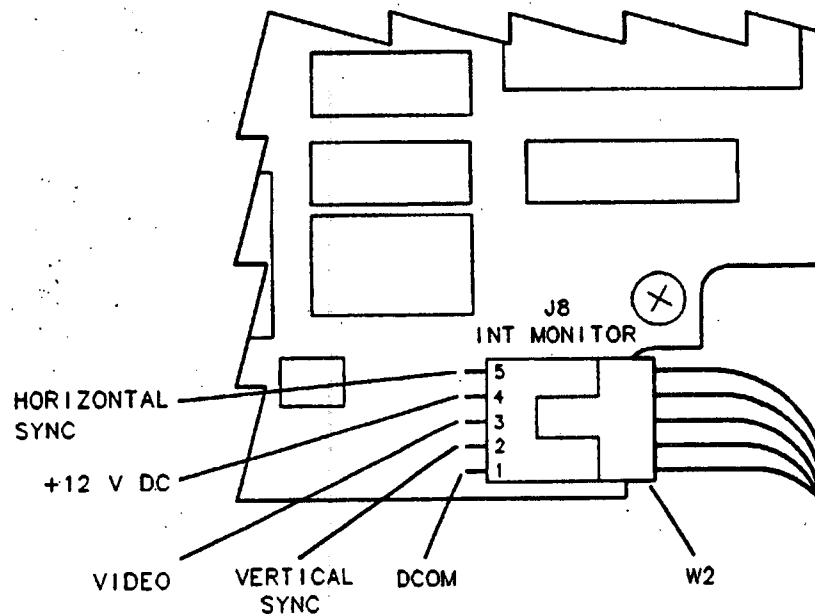

Figure 6-3. A16J8 Display Signal Output Pins

3. Refer to Figure 6-3 for the location of the test points and measure the following signals, using an oscilloscope:
 - A16J8 pin 1: signal ground. Check for ground connection to DCOM.
 - A16J8 pin 2: vertical sync signal. Check for a 60 Hz TTL signal with a pulse width of approximately 0.5 milliseconds and a repetition rate of approximately 16.6 milliseconds.
 - A16J8 pin 3: video signal. Check for an approximately 3 V pk-pk video signal.
 - A16J8 pin 4: +12 V dc power supply.
 - A16J8 pin 5: horizontal sync signal. Check for a 19.2 kHz TTL signal with a pulse width of approximately 8 microseconds and a repetition rate of approximately 52 microseconds.

Check High-Power-Up Signal from the A8 Power Supply

The A8 Power Supply assembly sends the high-power-up (HPWRUP) signal to the A16 assembly after it receives the low-power-on (LPWRON) signal and the +5 V supply has stabilized. If HPWRUP is low, the display remains blank and the A16 failure LEDs (DS1 through DS16) will not come on during power-up.

If the video, horizontal, and vertical signals are missing, but the +12 V supply voltage is present, check the HPWRUP signal.

1. Check for the +5 V TTL HPWRUP signal at pin 54 on the A16J1. The A16J1 connector is on the trace side of the A16 assembly. Refer to Figure 6-4 for the numbering order of A16J1 connector-pins accessible from the component side of the A16 assembly.

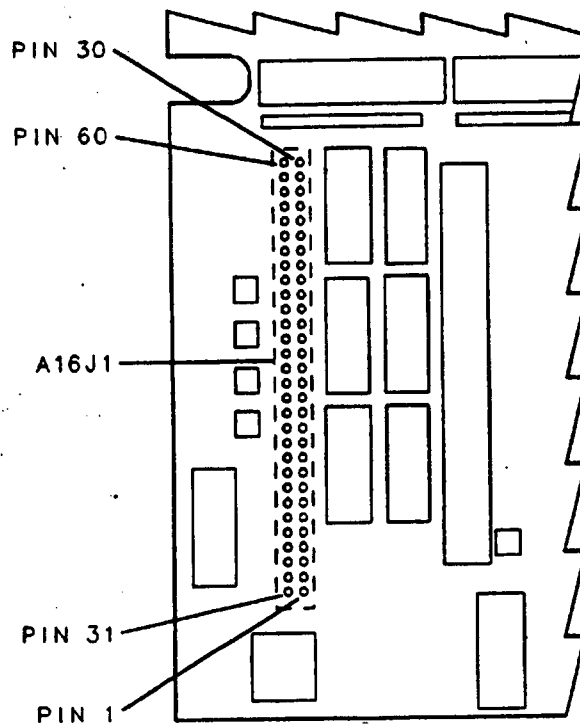

Figure 6-4. A16J1 Connector-Pin Orientation

2. If the HPWRUP signal is missing, trace the signal back through the A15 Motherboard to the A8 Power Supply assembly, pin 37 on A8J1. Refer to "A15 Motherboard Assembly" in Chapter 8 for the connector-pin designation of the HPWRUP signal path.

Note



The HPWRUP signal can be measured on pin 55 of each card-cage slot on the A15 Motherboard. Refer to Figure 6-5 for the numbering order of the connector pins on A15J3 through A15J6.

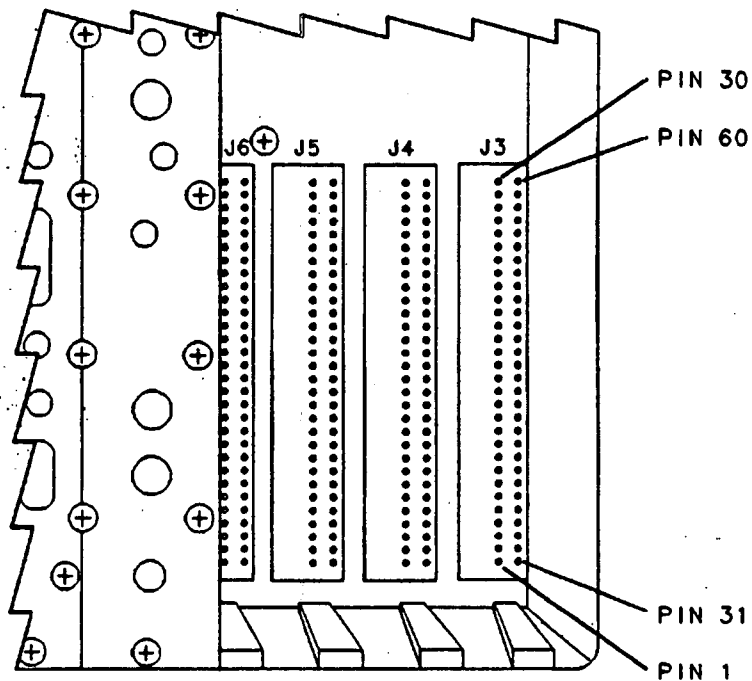

Figure 6-5. Card-Cage Connector-Pin Orientation

3. If the HPWRUP signal is present, yet one or more of the A16 outputs is incorrect, suspect a defective A16 Processor/Video assembly. Before replacing the A16 assembly refer to "A16 Memory Reset" in Chapter 9.
4. If all the A16 display outputs are correct, suspect a defective A2 Display.

Check for a Defective A2 Display

Warning



High voltage is present within the A2 Display and remains for some time after it has been disconnected. Be careful while troubleshooting the display outside of its enclosure.

If an A2 Display assembly failure is suspected, the display must be removed from its enclosure for further troubleshooting. Refer to the A2 Display assembly removal procedure in Chapter 3 before checking the continuity of the W2 and W3 wire harnesses. If both W2 and W3 are good, suspect the A2 Display.

The A2 Display is not field-repairable, and must be replaced as an assembly. Refer to Chapter 4 for ordering instructions.

After replacement, adjust the new display with the procedures from the Display Adjustments section in Chapter 2.

Symptoms of a Dead Battery

A dead BT101 battery will cause the loss of all correction-factor and correction-constant data. When the data stored in memory is lost, the spectrum analyzer normally substitutes the default-correction data stored in ROM and performs the instrument-preset routine.

If a Random Display Periodically Flashes on Screen

The spectrum analyzer did not load the default-correction data and cannot perform an instrument preset. The CPU is cycling slowly but is not able to recover.

Note



Allow approximately 2 seconds between each key press so that the CPU has time to respond.

Although the softkeys are not visible, load the default-calibration data by performing the following steps:

1. Press **FREQUENCY**.
2. Enter the -37 Hz passcode.
3. Press **CAL**.
4. Press the lowest softkey—**MORE 1 OF 3**.
5. Press the lowest softkey again—**MORE 2 OF 3**.
6. Press the third softkey from the top—**DEFAULT CAL DATA**.

After the default-calibration data is accepted, the spectrum analyzer should recover by performing an instrument preset.

- If the spectrum analyzer does not recover, repeat the steps above.
- If a normal display appears, continue at "Verify that the Correction Data is Missing."

If the Error Message FAIL: 0330 0000000000 Appears

The spectrum analyzer has successfully recovered by substituting the default-calibration data for the missing correction data and performing an instrument preset.

The following display sequence is normal when the spectrum analyzer recovers from a loss of RAM memory.

1. An empty rectangle appears.
2. The message SYMTAB EMPTY appears in the rectangle.
3. After approximately 8 seconds, the spectrum analyzer performs an instrument preset.
4. The error message FAIL: 0330 0000000000 is displayed.

Note



Either this display sequence, or the random, flashing display, will appear whenever the power-up sequence is repeated.

Verify that the Correction Data is Missing

Although the spectrum analyzer now appears to operate normally, it is no longer calibrated.

1. Confirm that the self-calibration correction-factor data has been replaced by the default-correction data:

Look at the default-data provided with the **DEFAULT CAL DATA** softkey description in Chapter 10.

Use **DISPLAY CAL DATA** to retrieve the current correction-data.

Compare the current correction-factor data to the default correction-data. If they match, the current correction-factor data has been lost.

2. Confirm that the correction-constant data is invalid:

Look at the current correction-data retrieved by **DISPLAY CAL DATA**.

If the first five entries in the ERR column contain zeros, the amplitude correction-constants for the A12 step-attenuators have been lost.

Use **EDIT FLATNESS** to review the flatness-correction constants. If the error message **INVALID FLATNESS DATA** appears, the flatness-correction constants have been lost.

3. If the battery is dead, replace it using the BT101 Battery replacement procedures in Chapter 3. Leave the instrument cover off to allow access to the area surrounding the battery.

After Replacing the Battery

After replacing the dead battery, verify that it is operating correctly using the following procedure.

1. Connect the spectrum analyzer to ac power.
2. Turn the spectrum analyzer on and allow it to run for at least 1 hour. It takes approximately 1 hour for the new battery to charge C106, the holding capacitor, to a level where the charging current stabilizes. A charge current of no more than 24 μ A ensures the 5-year life of the battery.
3. Disconnect the spectrum analyzer from ac power.
4. Position the spectrum analyzer with the A16 assembly facing up.
5. Locate R103, a 1 k Ω resistor, to the right of the battery, near the rear edge of the A16 assembly. The resistor is in series with the battery.
6. Measure the voltage across the 1 k Ω resistor. When the battery supply circuit is operating normally, no more than 24 mV is present across the resistor. If the voltage is greater than 24 mV, replace the A16 assembly or troubleshoot the circuit with component-level information from the A16 assembly CLIP.

Quickly confirm that the instrument can store data correctly in memory:

1. Connect the spectrum analyzer to ac power.
2. Enter the -2001 Hz passcode prior to pressing **CAL**.
3. Use **SET ATTN ERROR** to store five temporary A12 step-attenuator values.

4. Cycle the instrument power.
5. Recall the correction data with **DISPLAY CAL DATA**.
6. If the first five entries in the ERR column contain the values entered with **SET ATTN ERROR**, the memory-loss problem has been corrected.

Instrument Recalibration after a Battery-Backed RAM Memory Loss

To fully recalibrate the instrument, perform the steps in "Spectrum Analyzer Recovery after a A16 Memory Loss" in Chapter 9.

Locating an RF/LO/IF or Video Problem

This section provides techniques for isolating amplitude failures along the signal path from the spectrum analyzer input to the A16 Processor/Video assembly. For frequency failures refer to "LO Section" in Chapter 7. These troubleshooting methods isolate the failure to one of four functional sections in the spectrum analyzer:

- The RF section. This section includes the assemblies from the spectrum analyzer input to the output of the A9 Third Converter assembly.
- The LO section. This section involves the assemblies that provide a local oscillator output to the RF section. The A25 Counter Lock assembly is one of the assemblies involved.
- The IF section. This section includes the assemblies from the output of the A9 Third Converter to the output of the A14 Log Amplifier assembly.
- The video section. This includes the circuitry from the output of the A14 Log Amplifier assembly to the ADC section on the A16 Processor/Video. This section of the spectrum analyzer processes the detected 21.4 MHz IF signal from the IF section.

Once the problem has been isolated to one of the four sections, use standard troubleshooting methods to locate the source of the failure.

Techniques for Isolating an RF/LO/IF or Video Failure

Generally, the following troubleshooting techniques, in the order provided, are effective for isolating amplitude failures. The use of these procedures for specific failure symptoms is demonstrated in "RF/LO/IF and Video Failure Symptoms", below.

1. With the failure symptoms present, switch the spectrum analyzer from positive-peak detector to sample-detector mode.
 - If the spectrum analyzer returns to normal operation, the positive-peak detector is defective.
 - If the failure symptoms remain, continue at the next step.
2. Use the service diagnostic functions, **2V REF DETECTOR** and **GND REF DETECTOR** to verify that the main ADC on the A16 assembly is operating correctly. Refer to Chapter 10 for information about the use of service-related softkeys. Refer to Foldout 6-2, IF/Control Overall Block Diagram, for an overview of the A16 assembly.
 - If either top-screen (2 V) or bottom-screen (0 V) are not correct, suspect the ADC circuitry on the A16 assembly.
 - If the top-screen and bottom-screen signal positions are correct, the A16 signal-processing circuitry from the MUX, located just before the ADC, through the A16 assembly is operating normally.
3. Use **DISPLAY CAL DATA** to find the DAC value used to adjust the gain at the output of the A9 Third Converter assembly. The DAC value is in the REF LVL CAL DAC block in the second column. Refer to Chapter 10 for information about **DISPLAY CAL DATA**.

The DAC value is unique for each spectrum analyzer. The **CAL AMPTD** self-calibration routine adjusts this value based on the amplitude of the digitized video signal on the A16 assembly. The calibration routine makes this adjustment while calibrating the reference level at top-screen.

After running the **CAL AMPTD** routine, the REF LVL CAL DAC has a typical value of 165 with a range from 130 to 185. The higher the DAC value, the greater the output from the A9 assembly.

If **DEFAULT CAL DATA** is used, a default DAC value of 200 replaces the current value.

If the DAC value is 0 or 255, there is a significant gain problem in the RF/LO sections or the IF section. Either DAC value indicates that the **CAL AMPTD** routine was not able to calibrate the spectrum analyzer. Continue at the next step.

4. Refer to Foldout 6-2 and read "IF Power-Level Measurement."
5. Set up the instrument as shown in "Instrument Settings for IF Power-Level Measurement."
6. Measure the output of the A9 assembly using the procedure in "Measurement of the IF Signal from the A9 Third Converter."
 - If the REF LVL CAL DAC value is 255 and the A9 output is above the test limit, suspect a low gain problem in the IF section. Continue with the troubleshooting procedures in "Instrument Settings for IF Power-Level Measurement."
 - If the REF LVL CAL DAC value is 255 and the A9 output is below the test limit, suspect a low gain problem in the RF/LO sections.
 1. Set up the instrument as shown in "Instrument Settings for RF Power-Level Measurement." Refer to Foldout 6-1.
 2. Isolate the failure to an RF or LO assembly by taking RF and LO power-level measurements using the values in Table 6-4.
 - If the REF LVL CAL DAC value is 0 and the A9 output is above the test limit, suspect a high gain problem in the RF section.
 1. Set up the instrument as shown in "Instrument Settings for RF Power-Level Measurement." Refer to Foldout 6-1.
 2. Isolate the failure to an RF or LO assembly by taking RF and LO power-level measurements using the values in Table 6-4.
 - If the REF LVL CAL DAC value is 0 and the A9 output is nominal, suspect a high gain problem in the IF section. Continue with the troubleshooting procedures in "Instrument Settings for IF Power-Level Measurement."

RF/LO/IF and Video Failure Symptoms

The following failure symptoms are examples of problems where the failure-isolation methods presented in the previous section are effective. Each symptom is accompanied by additional troubleshooting hints used with the methods described earlier in "Locating an RF/LO/IF or Video Failure."

Failure Symptom: No signal or noise floor is present, only a horizontal trace at bottom screen.

- Check for a peak-detector failure by switching between the positive-peak detector and sample detector modes.
- Check for an ADC failure on the A16 assembly using the **2v REF DETECTOR** and **GND REF DETECTOR** functions.

- Check the signal path from the spectrum analyzer input to the output of the A14 Log Amplifier assembly. Refer to steps 4 through 6 in "Locating an RF/LO/IF or Video Failure."
- Check the output of the 1st, 2nd, and 3rd LO. Refer to "Instrument Settings for RF Power-Level Measurement" and Foldout 6-1.

Failure Symptom: The spectrum analyzer displays a low signal level that causes a self-calibration routine to stop. There is no noticeable frequency error.

- Check the amplitude of the CAL OUT signal and ensure that the CAL OUT signal is properly connected to the spectrum analyzer input. (The self-calibration routines perform an initial set-up check. If the signal level is below -40 dBm, the routine stops.)
- Use **DEFAULT CAL DATA** to set the REF LVL CAL DAC to a default value of 200.
- Check the signal path from the spectrum analyzer input to the output of the A14 Log Amplifier assembly. Refer to steps 4 through 6 in "Locating an RF/LO/IF or Video Failure."

Failure Symptom: A low signal level causes the **CAL AMPTD** self-calibration routine to fail after the initial set-up check is passed.

- Check the current correction factor for the REF LVL CAL DAC using **DISPLAY CAL DATA**.

Later firmware revisions stop the calibration routine if the REF LVL CAL DAC reaches either 0 or 255. The routine does not store the correction factors from an incomplete calibration; however, the corrections from the incomplete calibration are temporarily retained and can be viewed using **DISPLAY CAL DATA**. Refer to Chapter 11 for the description of the displayed error message.

Note



Firmware revisions 11.7.89 and 18.7.89 do not stop the **CAL AMPTD** routine if the REF LVL CAL DAC value is set to 0 or 255.

- Check the signal path from the spectrum analyzer input to the output of the A14 Log Amplifier assembly. Refer to steps 4 through 6 in "Locating an RF/LO/IF or Video Failure."

Failure Symptom: The **CAL AMPTD** self-calibration routine passes but the spectrum analyzer has a high noise floor. The spectrum analyzer may also fail the displayed average noise specification.

This problem is caused by low gain somewhere along the RF or IF signal path.

The calibration routine compensates for the low gain by increasing the gain of the A9 Third Converter assembly using the REF LVL CAL DAC. The excessive gain may cause the high noise floor by amplifying the noise level from the RF section or over-driving a stage in the IF section.

- Check the DAC value using **DISPLAY CAL DATA**. This type of problem causes the DAC value to be close to the 255 maximum.

- Check the signal path from the spectrum analyzer input to the output of the A14 Log Amplifier assembly. Refer to steps 4 through 6 in “Locating an RF/LO/IF or Video Failure.”
- Refer to “IF Section Information” in Chapter 8 for information about the gain settings of each IF assembly.

Failure Symptom: The displayed signal is too high and the **CAL AMPTD** self-calibration routine did not fail.

This problem is caused by high gain somewhere along the RF or IF signal path. The displayed CAL OUT signal appears to have an amplitude greater than -20 dBm. The excessive gain causes a calibration error that makes the CAL OUT signal appear higher than normal.

- Check for a REF LVL CAL DAC value of 0 using **DISPLAY CAL DATA**. The values in the ERR column are 0.00 or have a negative value.
- Check the signal path from the spectrum analyzer input to the output of the A14 Log Amplifier assembly. Refer to steps 4 through 6 in “Locating an RF/LO/IF or Video Failure.”
- Refer to “IF Section Information” in Chapter 8 for information about the gain settings of each IF assembly.

Failure Symptom: The displayed signal is distorted with distinct lobes on each side. A high noise floor may also be present.

Note



An intermittent hardware failure during the **CAL AMPTD** self-calibration routine can cause this type of amplitude failure. The erroneous calibration data causes the failure symptoms even while the hardware is operating normally.

- If the signal looks normal when **CORRECT ON OFF** is off, check the values in the RFATN and SGAIN columns using **DISPLAY CAL DATA**.

If a correction factor in either column is greater than two, there may be a failure on the A3A5 Input Attenuator or the A12 Amplitude Control assembly.

Refer to Chapter 10 for the description of the corrections that are disabled when **CORRECT ON OFF** is off.

- Troubleshoot the input attenuator or step gain symptoms with **CORRECT ON OFF** turned off.
- Check the signal path from the spectrum analyzer input to the output of the A14 Log Amplifier assembly. Refer to steps 4 through 6 in “Locating an RF/LO/IF or Video Failure.”
- Refer to “IF Section Information” in Chapter 8 for information about IF gain versus reference level for each IF assembly.

Note

Recalibrate the spectrum analyzer after the adjustment or replacement of each suspect assembly. A functioning spectrum analyzer may still appear to be defective if calibration data from before the repair is used.

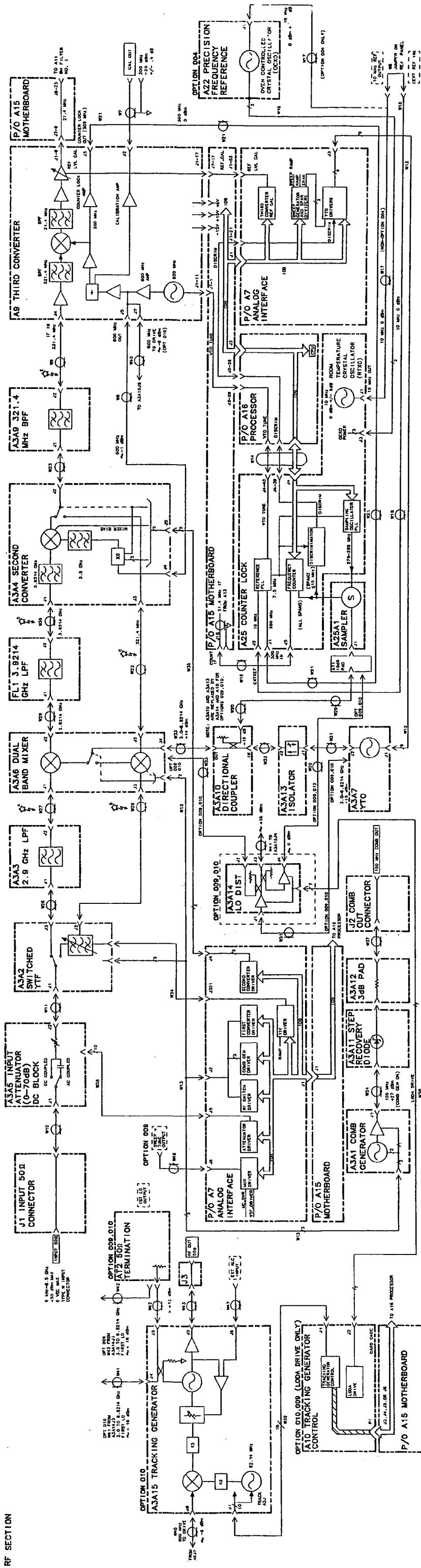

FOLDOUT 6-1. HP 8595A RF SECTION, OVERALL BLOCK DIAGRAM

RF/LO Section Troubleshooting

Introduction

This chapter provides detailed troubleshooting information for the RF and LO sections of the spectrum analyzer. Troubleshooting information is also provided for A9 Third Converter and A25 Counter Lock assemblies.

Refer to Chapter 6 for an overview of spectrum analyzer operation and troubleshooting procedures that are useful when first starting to troubleshoot a spectrum analyzer failure.

Before You Start Troubleshooting

There are three things you must do *before* you begin troubleshooting an instrument failure:

- Familiarize yourself with the safety symbols marked on the spectrum analyzer, and read the general safety instructions and the symbol definitions given in the front of the Service Manual.
- The spectrum analyzer contains static sensitive components. Read the section entitled "Protection From Electrostatic Discharge" in Chapter 1.
- Become familiar with the organization of the troubleshooting information in Chapter 6 and the information in this chapter.

Warning



The spectrum analyzer contains potentially hazardous voltages. Refer to the safety symbols on the spectrum analyzer and the general safety instructions in this manual before operating the unit with the cover removed. Failure to heed the safety precautions can result in severe or fatal injury.

RF Section Information

Note



The function-block letter designators shown in the block diagram correspond to the designators on the assembly schematic in the CLIP. The block diagram also indicates which function blocks are on each schematic sheet.

The RF Section includes the following assemblies:

- A3A1 Comb Generator
- A3A2 Switched YTF (YIG-Tuned Filter)
- A3A3 2.9 GHz LPF
- A3A4 Second Converter
- A3A5 Input Attenuator DC Block
- A3A6 Dual Band Mixer
- A3A9 321.4 MHz Low Pass Filter
- A3A11 Step Recovery Diode
- A3A12 3 dB Pad
- A3A15 Tracking Generator (Option 010)
- A7 Analog Interface
- A9 Third Converter
- FL1 3.9214 GHz Low Pass Filter

For details about the operation of the RF section, refer to Foldout 7-1, RF Section Block Diagram, at the end of this section.

RF Section Operation

The RF section converts all input signals to a fixed 21.4 MHz IF. The microcircuits in the RF section are controlled by signals from the A7 Analog Interface assembly. The A7 assembly also includes circuitry for controlling the LO and IF sections.

Five frequency bands cover the spectrum analyzer input range:

- Band 0 has a frequency range of 9 kHz to 2.9 GHz.
- Band 1 has a range of 2.75 to 6.5 GHz.

Band 0 (low band) uses triple conversion to produce the final 21.4 MHz IF. The A3A6 Dual Band Mixer up-converts the RF input to a 3.9214 GHz 1st IF. The A3A4 Second Converter down-converts the 3.9214 GHz 1st IF to a 321.4 MHz 2nd IF. The A9 Third Converter down-converts the second IF to the final 21.4 MHz IF.

Band 1 (high band) use double conversion. The A3A6 Dual-Band Mixer down-converts the RF input to a 321.4 MHz 1st IF. Although this first IF passes through the A3A4 Second Converter, it bypasses the second mixer. The second and final conversion occurs in the A9 Third Converter where the first IF is down-converted to produce the final 21.4 MHz IF.

Control of the A3A5 Input Attenuator

The A7 Analog Interface assembly controls the three attenuator steps and blocking capacitor in the A3A5 Input Attenuator using eight control lines. Refer to Foldout 7-1, RF Section Block Diagram, at the end of this section. Each attenuator step requires two control lines, as shown in Table 7-1. The attenuator is connected to A7J5 on the A7 assembly with the ribbon cable, W36. Locate W36 using the top view of the spectrum analyzer in Chapter 6.

Use a digital multimeter (DMM) and the values from Table 7-1 to check the control voltages. Measure the voltages at the A7J5 pins on the trace side of the A7 assembly.

Table 7-1. Input Attenuator Control Output at A7J5

Attenuator Setting (dB)	10 dB Step		40 dB Step		20 dB Step		Blocking Capacitor	
	Pin 2	Pin 1	Pin 9	Pin 4	Pin 8	Pin 5	Pin 7	Pin 6
0	H	L	H	L	H	L	—	—
10	L	H	H	L	H	L	—	—
20	H	L	H	L	L	H	—	—
30	L	H	H	L	L	H	—	—
40	H	L	L	H	H	L	—	—
50	L	H	L	H	H	L	—	—
60	H	L	L	H	L	H	—	—
70	L	H	L	H	L	H	—	—
Blocking Capacitor In	—	—	—	—	—	—	L	H
Blocking Capacitor Out	—	—	—	—	—	—	H	L

H = -10 V (with the attenuator connected at A7J5)
H = 0 V (A floating output if the attenuator is disconnected.)
L = -15 V (A low at pin 2, 9, or 8 indicates that the attenuator step is in the signal path. A low at pin 7 indicates the blocking capacitor is in the signal path.)

LO Section Information

Note



The function-block letter designators shown in the block diagram correspond to the designators on the assembly schematic in the CLIP. The block diagram also indicates which function blocks are on each schematic sheet.

The LO Section includes the following assemblies:

- A3A7 YTO (YIG-Tuned Oscillator)
- A3A10 Directional Coupler
- A3A13 Isolator
- A7 Analog Interface
- A9 Third Converter
- A22 Precision Frequency Reference (Option 004 only)
- A25 Counter Lock
- AT1 10 dB Pad

Refer to Foldout 7-2, LO Section Block Diagram, at the end of this section for details about the operation of the LO section.

The LO section provides a 3.0 to 6.8214 GHz 1st LO, a 600 MHz 2nd LO, a 300 MHz 3rd LO, a 300 MHz CAL OUT signal, and an IF frequency counter. The counter and the local oscillators use one of two 10 MHz frequency references: the standard room temperature crystal oscillator (RTXO) that is located on the A25 assembly; or the A22 Precision Frequency Reference, oven-controlled crystal oscillator (OCXO), Option 004.

The 10 MHz reference phase-locks the 600 MHz oscillator on the A9 Third Converter. The 600 MHz signal drives the second converter and is divided to produce the 300 MHz 3rd LO and CAL OUT signals. A 300 MHz signal that is sent to the A25 assembly is divided down further to produce a 7.5 MHz reference signal. This 7.5 MHz reference is used by the stabilizer, the sampling oscillator, and frequency counter. The phase-frequency detector is located on the A25 assembly.

The 1st LO output of the A3A7 YTO is fed through the A3A13 Isolator to the A3A10 Directional Coupler. The main output of the coupler is sent to the A3A6 Dual-Band Mixer. The coupled output is fed through the AT1 10 dB Pad to the A25A1 Sampler. The sampler mixes the 1st LO with a harmonic of the sampling oscillator to generate a 60 to 100 MHz sampler IF. This value is then divided by 10, producing a 6 to 10 MHz output.

During retrace, the YTO is locked to the selected 1st LO frequency. The divided sampler IF is then counted in the frequency counter. The YTO tune DACs on the A7 assembly are adjusted until the counted frequency is equal to the desired frequency. In LO spans less than or equal to 10 MHz, the divided sampler IF is also fed to a stabilizer, which generates the DISCRIM (discriminator) signal. DISCRIM tunes the YTO precisely to the desired 1st LO frequency.

When a trigger signal occurs, a sweep ramp is applied to the main coil drivers while in LO spans greater than 10 MHz, or to the FM coil drivers while in LO spans less than or equal to 10 MHz. During a main coil sweep, the sampling oscillator is disconnected from the A25A1 Sampler.

In frequency count mode, the 1st LO sweeps up to the marked signal and pauses. The divided sampler IF is counted to calculate the actual 1st LO frequency. Then the prescaled 21.4 MHz IF, nominally 5.35 MHz, is counted and the actual input frequency calculated.

A9 Third Converter Assembly

Note



The function-block letter designators shown in the block diagram correspond to the designators on the assembly schematic in the CLIP.

The A9 Third Converter performs the following functions:

- Down-converts the 321.4 MHz IF to the final 21.4 MHz IF.
- Generates the 300 MHz 3rd LO.
- Provides variable gain from the calibrator amplifier that adjusts the amplitude of the 21.4 MHz IF during the spectrum analyzer **CAL AMPTD** self-calibration routine.
- Generates the 600 MHz 2nd LO drive signal for the A3A4 Second Converter assembly and for the tracking generator (Option 010).
- Generates the 300 MHz CAL OUT signal at -20 dBm.
- Provides a buffered 300 MHz to drive the external reference PLL circuitry on the A25 Counter Lock assembly.

Refer to Foldout 7-3, A9 Third Converter Assembly Block Diagram, at the end of this section for details about the operation of the A9 assembly.

Refer to "A15 Motherboard Assembly" in Chapter 8 when tracing control signals for the A9 assembly.

The output of the 600 MHz surface acoustical wave (SAW) oscillator is buffered, providing the 2nd LO signal to the A3A4 Second Converter. This signal is further buffered, divided by two, and buffered again to produce three 300 MHz outputs. A second 600 MHz output drive signal is available for the tracking generator (Option 010).

The amplitude of the 300 MHz signal from the Calibrator Amplifier is adjusted to provide the -20 dBm output for the 300 MHz CAL OUT signal. This amplifier produces rich harmonics that are used in the spectrum analyzer self-calibration routines.

The 300 MHz signal sent to the 300 MHz Buffer produces the other two 300 MHz outputs:

- The 300 MHz 3rd LO sent to the Mixer/Filter.
- The 300 MHz feedback signal sent to the A25 Counter Lock assembly by the counter lock buffer. This signal is divided down and compared to the 10 MHz reference in a phase/frequency detector on the A25 assembly. The output of the phase/frequency detector, VTO_TUNE, is fed back to the 600 MHz SAW Oscillator to increase its frequency stability.

The 321.4 MHz 2nd IF signal from the A3A4 Second Converter is amplified and bandpass-filtered on the A9 assembly. This signal is mixed with the 300 MHz 3rd LO to produce the 21.4 MHz difference signal that is then bandpass-filtered and buffered.

The buffered 21.4 MHz IF signal is amplified in the IF Calibration Amplifier (IF Cal Amp). The gain of the calibration amplifier is controlled by a DAC on the A7 Analog Interface assembly via the REF_LVL_CAL control line. During the CAL AMPTD routine, the gain of the calibration amplifier is adjusted so that the reference level at top-screen is calibrated. The amplitude reference for the routine is provided by the -20 dBm CAL OUT signal with 10 dB of input attenuation in band 0. Refer to "IF Power-Level Measurement" in Chapter 6 for more information about the 21.4 MHz output from the A9 assembly.

A25 Counter Lock Assembly

Note



The function-block letter designators shown in the block diagram correspond to the designators on the assembly schematic in the CLIP.

The A25 Counter Lock assembly performs four main functions:

- Phase-locks the 600 MHz SAW oscillator on the A9 Third Converter to the 10 MHz reference.
- Counts the 1st LO frequency.
- Provides discriminator output, DISCRIM, to the A7 Analog Interface assembly.
- Counts the 21.4 MHz IF.

Refer to Foldout 7-4, A25 Counter Lock Assembly Block Diagram, at the end of this section for details about the operation of the A25 assembly.

On the A9 Third Converter, the output of the 600 MHz oscillator is divided by two and the resulting 300 MHz signal is routed to the A25 assembly. The A25 assembly divides the 300 MHz signal by 40 to generate a 7.5 MHz reference for the sampling oscillator, stabilizer, and frequency counter. The 7.5 MHz reference and the 10 MHz reference are divided further and compared in a phase-frequency detector. The output of the phase-frequency detector, VTO.TUNE, is fed back to A9 to tune the 600 MHz oscillator.

The sampling oscillator provides a 279 to 298 MHz driving signal to the A25A1 Sampler. The 1st LO signal is also applied to A25A1. The 1st LO signal is mixed with a harmonic of the sampling oscillator signal to generate the sampler IF. This IF is divided by 10 and fed to one input of the frequency counter. The equation used to produce the 1st LO frequency is:

$$\text{1st LO Frequency} = N \times F_{SO} + \text{Sampler IF}$$

N represents the harmonic of the sampling oscillator.

F_{SO} represents the sampling oscillator frequency.

Sampler IF represents the counted sampler IF (may be negative).

The stabilizer mixes the divided sampler IF (nominally 8.25 MHz) with the 7.5 MHz, and feeds the difference signal into the discriminator. The discriminator output, DISCRIM, is fed back to the A7 Analog Interface assembly to tune the A3A7 YTO precisely to the center frequency.

When the frequency count marker is active, the spectrum analyzer pauses at the marked frequency and counts the 1st LO as described previously. The 21.4 MHz IF is then divided by four, to a nominal value of 5.35 MHz, fed to another frequency counter input, and counted. With the 2nd LO, the 3rd LO, the counted 1st LO, and the counted final IF all referenced to the 10 MHz reference, the actual input signal frequency is calculated.

A3A15 Tracking Generator

Description

The A3A15 Tracking Generator assembly consists of several smaller circuits. The A3A15 assembly is not component-level repairable; a rebuilt exchange assembly is available.

The tracking generator recreates only one of the spectrum analyzer's intermediate frequencies. This minimizes isolation problems associated with a built-in tracking generator. Each of the blocks of the A3A15 Tracking Generator assembly is described below.

Refer to Foldout 7-1, "HP 8595A RF Section Block Diagram," and Foldout 7-3, "HP 8595A Option 010 A10 Tracking Generator Control Block Diagram," for details about the operation of the tracking generator.

Tracking Oscillator

The tracking oscillator enables the fine adjustment of the tracking generator output frequency to compensate for the frequency inaccuracies of the spectrum analyzer's 21.4 MHz IF. The tracking oscillator determines the residual FM and frequency drift of the tracking generator. The 184.28 MHz output frequency is obtained by doubling the output of a crystal oscillator operating at 92.14 MHz.

Upconverter

The upconverter mixes the tracking oscillator output with the buffered 600 MHz reference from the A9 Third Converter assembly. The upconverter also contains a filter to pass only the 784.28 MHz upper sideband.

Pentupler

The pentupler multiplies the 784.28 MHz signal by five to generate 3.9214 GHz, the spectrum analyzer's 1st IF in low band. A dual cavity bandpass filter centered at 3.9214 GHz eliminates all unwanted multiples of 784.28 MHz.

Modulator

The output of the pentupler is passed through a modulator to adjust the power level into the output mixer. The modulator is controlled by an ALC circuit on the bias board, which is fed by a detector in the output amplifier. If the detected output power is too high, the ALC will drive the modulator to decrease the input level into the output mixer, resulting in a decrease in output power.

Coupler

The 1st LO signal from the A3A14 First LO Distribution Amplifier assembly is coupled off, then buffered to drive the output mixer. The main line of the coupler is fed to the LO OUTPUT connector on the rear panel. The loss through the coupler main line is less than 2.5 dB.

Output Mixer

The 3.9214 GHz signal from the modulator is fed into the RF port of the output mixer. The LO port of the output mixer is driven by the buffered 1st LO signal from the coupler. The output of the mixer is then amplified.

Output Amplifier

The output amplifier filters the signal emerging from the output mixer and then amplifies it into a usable range. The amplifier also contains a detector for leveling the output.

Bias Board

The bias board contains the ALC circuitry for the tracking generator and distributes dc power from the A10 Tracking Generator Control assembly to the rest of the tracking generator. The ALC inputs come from the A10 Tracking Generator Control assembly (for controlling the power level), the EXT ALC INPUT line, and the detector in the output amplifier. The ALC loop drives the modulator.

Tracking Generator Troubleshooting

The following troubleshooting information is aimed at isolating tracking-generator-related faults to either the A3A15 Tracking Generator assembly or one of the other supporting assemblies, such as A9, A10, or A3A14. The A3A15 Tracking Generator assembly is not field-repairable; a rebuilt-exchange assembly is available.

Output Goes Unleveled (TG UNLVL Message Displayed)

A window comparator on the A10 Tracking Generator Control assembly is used to monitor the control line ALC_MON (ALC Monitor) from A3A15 assembly. If ALC_MON is greater than +1.0 Vdc or less than -0.10 Vdc TG UNLVL will be displayed, indicating that the output of the tracking generator (or TG) is unleveled. The tracking generator can typically be set for +2.75 dBm output power and remain leveled. In any case, the output should remain leveled for output power settings of +1 dBm or less. It is normal for the tracking generator to be unleveled at frequencies below 300 kHz.

The ALC_MON line is continuously monitored during a sweep, but the TG UNLVL message will only be displayed at the end of the sweep. For this reason, it is possible that the output could be unleveled during a portion of a sweep, and although the output returns to a leveled condition by the end of the sweep, TG UNLVL will be displayed at the end of the sweep.

If TG UNLVL is displayed, proceed as follows:

1. Check at which frequencies the output is unleveled. Set the spectrum analyzer to zero span and step the center frequency in 50 MHz increments. Note at which frequencies the output is unleveled.
2. Check at which power levels the output is unleveled. Connect the RF OUT 50 Ω connector to the INPUT 50 Ω connector. With the spectrum analyzer in zero span, set CENTER FREQ to 300 MHz or one of the frequencies noted in step 1, with the spectrum analyzer in zero span. Press **AUX CTRL**, **TRACK GEN**, **SRC PWR ON OFF** (ON underlined), **TRACKING PEAK**. Wait for the PEAKING message to disappear. Step the SRC POWER setting in 1 dB increments and note at which power levels the output is unleveled. The output should be unleveled only when the power level is greater than +1 dBm.

3. Check maximum power available from the tracking generator. Connect the RF OUT 50 Ω connector to the INPUT 50 Ω connector. Press **PRESET**, **AMPLITUDE**, 20, **+dBm**, **LOG dB/DIV**, 5, **dB**, **AUX CTRL**, **TRACK GEN**, **SRC PWR ON OFF** (**ON** underlined), **MORE 1 OF 2**, **ALC INT EXT** (**EXT** underlined). The available power should always be greater than +1 dBm. If the output is unlevelled only at specific frequencies, a power hole will usually be visible at those frequencies.
4. Check the LO OUTPUT power level as follows:
 - a. Set the spectrum analyzer to zero span at a 0 Hz center frequency.
 - b. Zero and calibrate a power-meter/power-sensor combination. Set the power meter to readout power in dBm. Enter the power sensor's 4 GHz cal factor into the power meter.
 - c. Connect the power sensor to the LO OUTPUT connector on the spectrum analyzer's rear panel.
 - d. Record the power meter reading. The power level should be greater than +12.5 dBm.
 - e. Increase the spectrum analyzer's center frequency setting by 100 MHz. The LO OUTPUT frequency will be 3.9214 GHz greater than the center frequency setting.
 - f. Enter the appropriate power sensor cal factor into the power meter.
 - g. Repeat steps d through f until the center frequency setting is 2.9 GHz.
5. If the LO OUTPUT power-level check fails, note the center frequency setting at which the power level was out of tolerance. If the LO OUTPUT power level check passes, proceed to step 7.
6. Place the A3 Front End assembly in its service position. Place the A3A15 Tracking Generator assembly in its service position. Disconnect W41 from A3A15J4 (LO IN). Connect the power sensor to the free end of W41. Repeat the LO OUTPUT power level check above, noting the center frequency settings at which the power level is out of tolerance. The power level for this check should be +16.5 dBm \pm 2 dB.
 - If the power level is within tolerance at W41, but out of tolerance at the LO OUTPUT (rear panel), and the center frequency setting of the out-of-tolerance power levels is close to the frequencies at which the output is unlevelled, suspect A3A15.
 - If the power level at W41 is also out of tolerance, suspect either the A3A14 LODA assembly, A3A7 YTO assembly, or W41. Refer to the "LO Section Information," in Chapter 7 of the Service Manual.
7. If the output is unlevelled only at certain power level settings or certain frequencies, monitor A10J1 pin 8 with a DVM. Connect the negative DVM lead to A7JTP1. Vary the SRC POWER setting or center frequency setting, as appropriate, and plot the voltage variation versus power level or frequency. A discontinuity in the plot near the frequency or power level at which the output is unlevelled indicates a problem on the A10 Tracking Generator Control assembly.

Excessive Residual FM

Either the tracking oscillator or the ALC circuitry could be responsible for excessive residual FM. The residual FM should be measured on another spectrum analyzer, such as an HP 8566A/B or HP 8568A/B, using slope detection with the HP 8595A set to zero span. Proceed as follows to troubleshoot residual FM problems:

1. Perform the Residual FM performance test for the spectrum analyzer (see the Installation, Verification, and Operation Manual). If this test passes, the 1st LO input and 600 MHz drive signals should be within tolerance. If the test fails, troubleshoot the LO section.
2. Monitor A10J1 pin 5 (TUNE) with an oscilloscope. Connect the oscilloscope probe ground lead to A7TP1. The voltage at this point should be greater than 500 mV.
 - If the voltage is less than 500 mV, perform the "Frequency Tracking Range Check" in the Tracking Oscillator adjustment procedure, in Chapter 2. If this check fails, perform the "Adjustment Procedure" which follows the "Frequency Tracking Range Check".
 - If the noise on this tune line is greater than 10 mV, troubleshoot the A10 Tracking Generator Control assembly.
3. Monitor the output of the tracking generator with another spectrum analyzer (the HP 8595A should be in zero span). Check for high-amplitude spurious responses from 100 kHz to at least 3 GHz. If the spurious responses are too high in amplitude, the (broadband) ALC detector may cause the ALC loop to oscillate, generating FM sidebands. If any spurious responses are excessively high, refer to "Harmonic /Spurious Outputs Too High" later in this section.
4. If no spurious responses are present, or if the spurious responses are sufficiently low enough in amplitude to not cause a problem, suspect the tracking oscillator in the A3A15 assembly.

Flatness Out of Tolerance

The output level flatness of the tracking generator is specified at a 0 dBm output power setting. In general, most flatness problems will be a result of a failure in the A3A15 Tracking Generator microcircuit. However, the PWR_LVL signal from the A10 Tracking Generator Control assembly and the 1ST LO IN signal from the A3A14 First LO Distribution Amplifier assembly can also contribute to flatness problems.

1. Check the function of the PWR_LVL signal from the A10 Tracking Generator Control assembly. Set the SRC POWER setting to a level at which the flatness is out of tolerance. Monitor A10J1 pin 8 with a DVM, step the center frequency setting in 100 MHz increments from 100 MHz to 2.9 GHz, and plot the voltage variation versus frequency. A discontinuity in the plot near the frequency at which the flatness is out of tolerance indicates a problem on the A10 Tracking Generator Control assembly.
2. Check the flatness of the 1ST LO IN signal. Perform the LO OUTPUT amplitude check as described in "Output Goes Unleveled (TG UNLVL Message Displayed)," section.
 - If the check passes, the fault is most likely in the A3A15 Tracking Generator assembly.
 - If the test fails, note the center frequency setting at which the power level was out of tolerance and compare against the frequencies at which the flatness was out of tolerance. Repeat the check with the power sensor connected to the end of W41 that is nearest the A3A15 assembly, noting the center frequency of any out of tolerance power levels. The power level should be $+16.5 \text{ dBm} \pm 2 \text{ dB}$.
 - If the power level is within tolerance at W41, but out of tolerance at the LO OUTPUT connector (rear panel), and the center frequency settings of the out-of-tolerance power levels are close to the frequencies at which the flatness is out of tolerance, suspect the A3A15 assembly.

- If the power level at W41 is also out of tolerance, suspect either the A3A14 First LO Distribution Amplifier or the A3A7 YTO assembly. Refer "LO Section Information," in Chapter 7 of the Service Manual.

3. Check all coax cables, especially semi-rigid cables. A fault in one of these cables can cause a very-high-Q power hole.

Vernier Accuracy Out of Tolerance

Vernier accuracy is a function of the PWR_LVL drive signal from the A10 Tracking Generator Control assembly and the ALC circuitry on A3A15. The vernier accuracy is specified at 300 MHz. Since vernier accuracy is tested using a broadband power sensor, abnormally high spurious responses could cause the measured vernier accuracy to fail when in fact the accuracy of the 300 MHz signal alone is within specification.

1. Check the PWR_LVL drive signal from A10. Monitor A10J1 pin 8 with a DVM. Change the SRC POWER setting in 1 dB steps and note the voltage at each power level setting. The voltage should change by the same amount for each 1 dB step. If the voltage does not change by the same amount for each 1 dB step, the fault lies on the A10 Tracking Generator Control assembly.
2. Check for abnormally high spurious outputs. Connect the RF OUT 50 Ω connector to the input of another spectrum analyzer (the test analyzer). Set the test spectrum analyzer to sweep from 300 kHz to 2.9 GHz, with a sweeptime of 100 msec or less. Set the HP 8595A to sweep from 300 kHz to 2.9 GHz with a 50 second sweeptime. Press **SGL SWP** on the HP 8595A and observe any responses on the test spectrum analyzer, ignoring the desired output signal. If any spurious responses are greater than -20 dBc, the vernier accuracy measurement may fail. Refer to "Harmonic/Spurious Outputs Too High" below.
3. Check for excessive LO feedthrough. Use the LO Feedthrough performance test in the Installation, Verification, and Operation Manual, but check over a center frequency range of 300 kHz to 100 MHz. The LO Feedthrough will be 3.9214 GHz greater than the center frequency setting.

Harmonic/Spurious Outputs Too High

Harmonic and spurious outputs may be generated by A3A15 itself or may be present on either the 600 MHz drive or 1st LO drive signal. There is a direct relationship between spurious signals on the 1st LO and spurious signals on the tracking generator output. There is a five-to-one relationship between spurious signals on the 600 MHz drive and the spurious signals on the tracking generator output. For example, if the 600 MHz signal moves 1 MHz, the tracking generator output signal will move 5 MHz. This is due to the multiplication in the pentupler.

1. If the Harmonic Spurious Responses performance test failed, connect another spectrum analyzer, such as an HP 8566A/B, to the HP 8595A LO OUTPUT connector. Set the HP 8595A to each frequency as indicated in the performance test, with the SPAN set to 0 Hz. The 1st LO frequency will be 3.9214 GHz greater than the center frequency setting. Use the HP 8566A/B to measure the level of the second and third harmonics of the 1st LO signal.

Note

The 1st LO typically has a higher harmonic content than the tracking generator output. For the purposes of this check, it is the variation in harmonic content versus frequency which is important.

If the variation of the harmonic level of the 1st LO versus frequency tracks the harmonic level variation of the tracking generator output, repeat step 1 while measuring the 1st LO signal at the end of W41 nearest A3A15. If there is little variation in the 1st LO harmonic level between the LO OUTPUT connector and W41, and the relative variation in harmonic level tracks with the tracking generator output harmonic level, suspect either the A3A14 First LO Distribution Amplifier assembly or the A3A7 YTO assembly.

If the harmonic level variation of the 1st LO versus frequency does not track the harmonic level variation of the tracking generator output, suspect A3A15.

2. If sidebands are present at the same frequency offset at every output frequency, use another spectrum analyzer to check the spectral purity of the 1st LO and the 600 MHz drive signals. When checking the 1st LO, the HP 8595A must be set to zero span. The 1st LO frequency will be 3.9214 GHz greater than the center frequency setting. A 1 MHz sideband on the 1st LO will appear as a 1 MHz sideband on the output signal.

To verify that the 600 MHz drive or 1st LO signal is responsible for the sidebands, substitute a clean signal for the 600 MHz drive or 1st LO signal. If the sidebands on the output disappear when using the clean signal, the substituted signal was responsible for the sidebands.

Note

The 600 MHz drive signal should be $-8 \text{ dBm} \pm 3.5 \text{ dB}$. The 1st LO signal should be $+16 \text{ dBm} \pm 2 \text{ dB}$.

Power Sweep Not Functioning Properly

Power sweep is accomplished by summing an attenuated SWEEP RAMP signal with the PWR_LVL signal. The SWEEP_RAMP is attenuated using the 12-bit power sweep DAC. The power sweep DAC output is then fed to a summing amplifier where it is summed with the power level DAC output to yield the PWR_LVL signal.

1. If some power sweep ranges do not appear to work properly, the fault is probably the power sweep DAC on the A10 Tracking Generator Control assembly. Check the operation of the power sweep DAC as follows:

- a. Monitor A10U9 pin 7 with an oscilloscope. Connect the ground lead of the oscilloscope to A10TP1. (Refer to the schematic for the A10 Tracking Generator Control assembly.) Trigger the oscilloscope using the spectrum analyzer's HIGH SWEEP IN/OUT signal on the rear panel.

- b. Set the spectrum analyzer controls as follows:

CENTER FREQ	300 MHz
SPAN	0 Hz
RES BW	300 kHz
SRC POWER	-10 dBm
SRC PWR SWEEP	10 dB

- c. The amplitude of the positive-going ramp displayed on the oscilloscope should be approximately 7.8V.
- d. Change the SRC PWR SWEEP setting to any value between 1 and 11 dB. The ramp amplitude displayed on the oscilloscope should be 780 mV per dB of the SRC PWR SWEEP setting.

Note

Although the source power sweep may be set to a 12.75 dB sweep width, the power sweep function is only warranted to have a 11 dB sweep width.

2. Perform the Vernier Accuracy performance test. See the Installation, Verification, and Operation Manual. If this test fails, refer to "Vernier Accuracy Out of Tolerance" earlier in this section.

No Power Output

The A3A15 assembly requires power supplies, a 1st LO signal, and a 600 MHz drive signal in order to provide power output.

1. Check the power supplies on A10J1 and A3A15J1. Refer to the A10 Tracking Generator Control assembly schematic.
2. Verify that the voltage at A10J1 pin 4 is greater than +14 Vdc when the tracking generator is on. If the voltage is not greater than +14 Vdc, troubleshoot A10.
3. Check that ALC_EXT, measured at A10J1 pin 10, is at a TTL low when the tracking generator is set to ALC INT and at a TTL high when the tracking generator is set to ALC EXT.
4. Check that the 600 MHz drive signal is $-8 \text{ dBm} \pm 3.5 \text{ dB}$. If the signal is outside of this range, troubleshoot the A9 Third Converter assembly.
5. Check that the 1st LO input signal is $+16 \text{ dBm} \pm 2 \text{ dB}$. Perform the LO OUTPUT amplitude check described in "Output Goes Unleveled (TG UNLVLD Message Displayed)" earlier in this section, measuring instead at the end of W41 nearest A3A15.
6. Check the tracking adjustment controls. Monitor A10J1 pin 5 with a DVM. On the HP 8595A, use the step keys and knob to change the MAN TRACK ADJUST value from 0 to 4095. The voltage measured should increase from 0 V to +12 V.

Caution

The following step requires adjustment of A3A15C3. The lifetime of A3A15C3 is rated for less than 10 cycles. Do not adjust A3A15C3 unless it is absolutely necessary.

7. If all of the checks above are acceptable, the tracking oscillator might not be functioning. Setup the HP 8595A as indicated in the Tracking Oscillator adjustment procedure in Chapter 2, using a spectrum analyzer, such as an HP 8566A/B, in place of the frequency counter. Try to adjust A3A15C3 until a signal is displayed on the HP 8566A/B. If adjusting A3A15C3 does not result in the tracking generator beginning to function, the A3A15 Tracking Generator assembly is suspect.

A3A14 First LO Distribution Amplifier (LODA)

Description

The A3A14 First LO Distribution Amplifier, (LODA), amplifies and levels the 1st LO signal from the A3A7 YTO and distributes it to the A25A1 Sampler (through attenuator AT1), A3A8 Dual Band Mixer, and A3A15 Tracking Generator. The leveling control circuitry is on the A10 Tracking Generator Control assembly.

The LODA consists of a PIN diode attenuator, an amplifier, three directional couplers, a buffer amplifier, and a detector. Refer to Foldout 7-2. All three directional couplers are connected in series. The main line of the directional couplers is the output to the A3A15 Tracking Generator assembly. The directional coupler outputs feed the A3A6 Dual Band Mixer, the detector, and the buffer amplifier for driving the A25A1 Sampler.

The detector output is fed to the A10 Tracking Generator Control assembly. Here it is fed into a loop integrator. The reference voltage for the loop integrator is adjustable and determines the output power of the LODA. The gate bias adjustment is also on A10. Note that the LODA drive circuit common is connected only to the A3A14 LODA itself and not to any other grounds on A10.

Refer to Foldout 7-2, "HP 8595A LO Section Block Diagram," for details about the operation of the A3A14 assembly.

First LO Distribution Amplifier Troubleshooting

The following troubleshooting information is aimed at isolating 1st LO amplitude-related faults to either the A3A14 LODA assembly, A10 Tracking Generator Control assembly, or the A3A7 YTO assembly. The A3A7 YTO and A3A14 LODA are not field repairable. The A10 Tracking Generator Control assembly is field repairable. However, if the repair time exceeds 30 minutes, it may be more cost-effective to order a replacement assembly rather than to continue component-level repair.

1. Place the A3 Front End assembly in its service position. Place the A10 Tracking Generator Control assembly on an extender board. Remove W33, the semi-rigid coax cable between A3A14 and A3A6. Do not reconnect W20 to AT1.
2. Connect a DVM's negative lead to A10TP2, AGND. Connect the positive lead to A10TP6 (PIN).
3. Set the spectrum analyzer controls as follows:

CENTER FREQ	300 MHz
SPAN	20 MHz
TRIGGER	SINGLE

4. Measure the LO power at A3A14J2 and the free end of W20. Refer to Foldout 7-2 for acceptable power level ranges.
5. If both LO power levels are lower than acceptable, the voltage on A10TP6 (PIN) should be above 0 V. If both LO power levels are higher than acceptable, this voltage should be more negative than -10 V.

6. If the voltage measured in step 5 is as described, the LODA drive circuitry is acceptable. Check the A3A7 YTO output power level. Refer to Foldout 7-2 for acceptable power level range.
7. If the voltage measured in step 5 is not as described, either the LODA drive circuitry or the LODA itself is malfunctioning. Check that the operational amplifier's output is consistent with its inputs.
8. Set the spectrum analyzer **LINE** switch to off, disconnect W38 from A10J2, then set the spectrum analyzer **LINE** switch to on.
9. Connect a jumper between A10J2 and A10TP2. This connects ground A2, a floating ground, to AGND. Connect another jumper between A10TP4, LOS (LO sense) and +10VR (refer to the A10 schematic).
10. The voltage measured on the DVM should be greater than +14 Vdc.
11. Move the jumper from +10VR to -10VR (refer to the A10 schematic). The voltage measured should be more negative than -13 Vdc.
12. If the voltages do not meet the limits described in steps 10 and 11, troubleshoot the A10 Tracking Generator Control assembly.
13. Connect the positive DVM lead to A10J2 pin 1.
14. The measured voltage should be approximately +5 Vdc. If the voltage is not +5 Vdc, troubleshoot the A10 Tracking Generator Control assembly.
15. Connect the positive DVM lead to A10TP5, GB (gate bias). The voltage should measure within 5% of the GATE voltage listed on the RF section label.
16. If the voltage is not within this range, rotate A10R29 (GATE) through its range while monitoring the DVM.
17. If the voltage varies between 0 Vdc and -2 Vdc, adjust A10R29 (GATE) for a DVM reading within 5% of the GATE voltage listed on the RF section label. If the voltage does not vary outside the range of 0 Vdc and -2 Vdc, troubleshoot the A10 assembly.
18. Set the spectrum analyzer **LINE** switch to off, reconnect W38 to A10J2, then set the spectrum analyzer **LINE** switch to on.
19. If the DVM reading changes more than 50 mV, the A3A14 LODA is probably defective.

RF SECTION

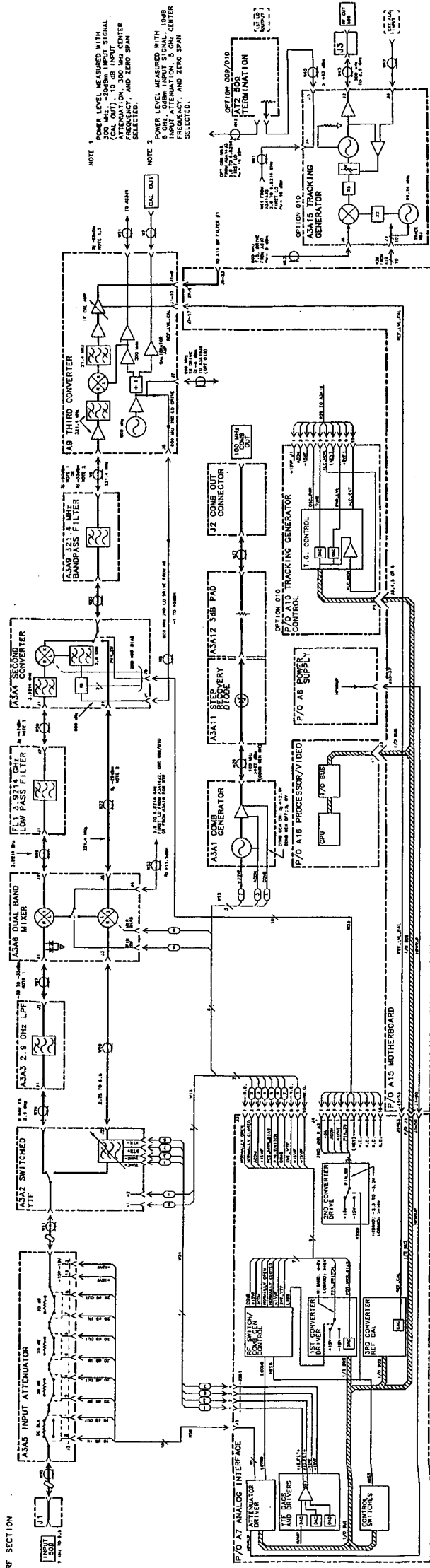
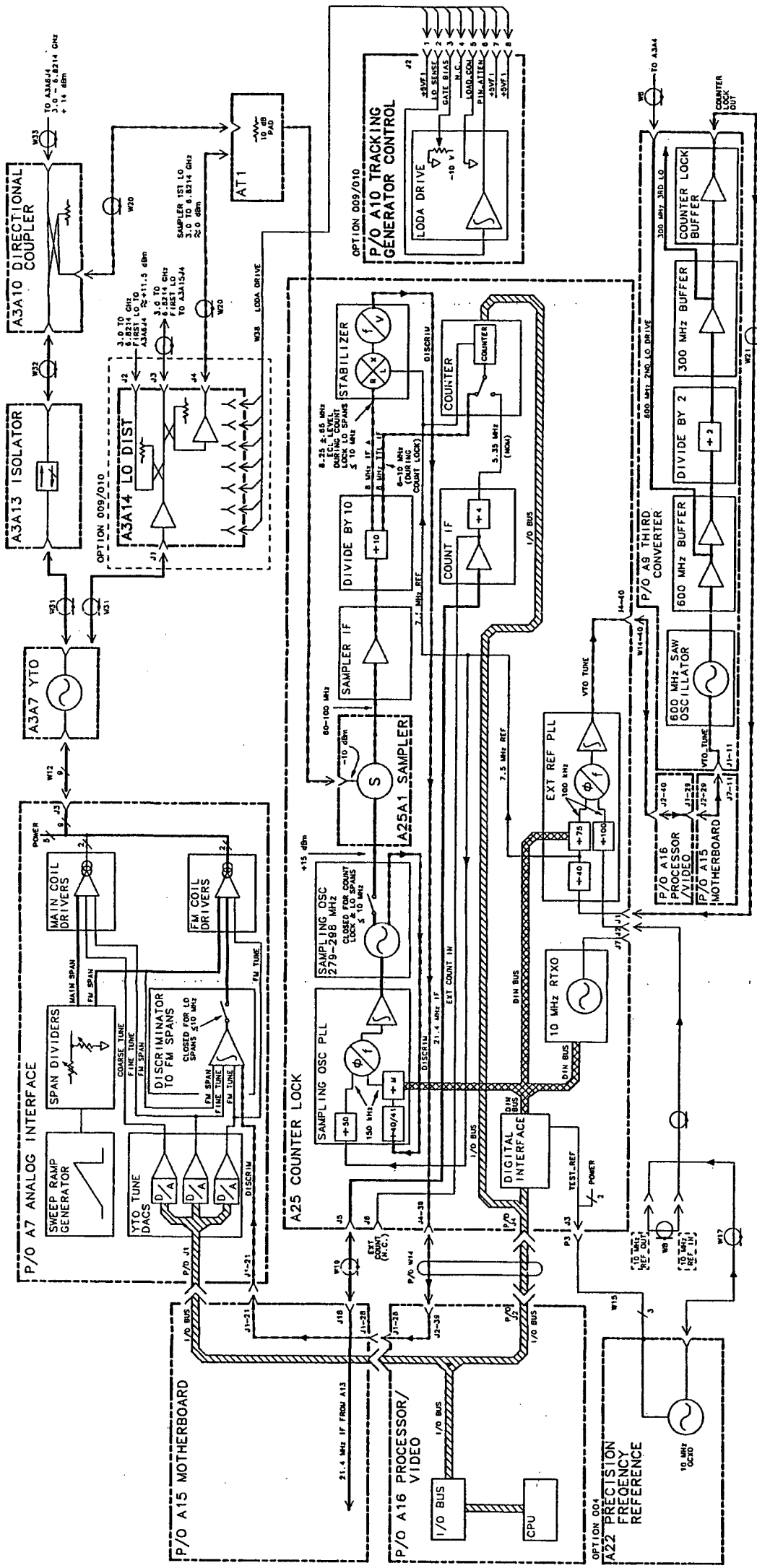

FIGURE 7-1. HP 8998A RF SECTION BLOCK DIAGRAM

RF/LO Section Troubleshooting



FOLDDOUT 7-2. HP 8595A LO SECTION, BLOCK DIAGRAM
RF/LO Section Troubleshooting

A9 THIRD CONVERTER ASSEMBLY

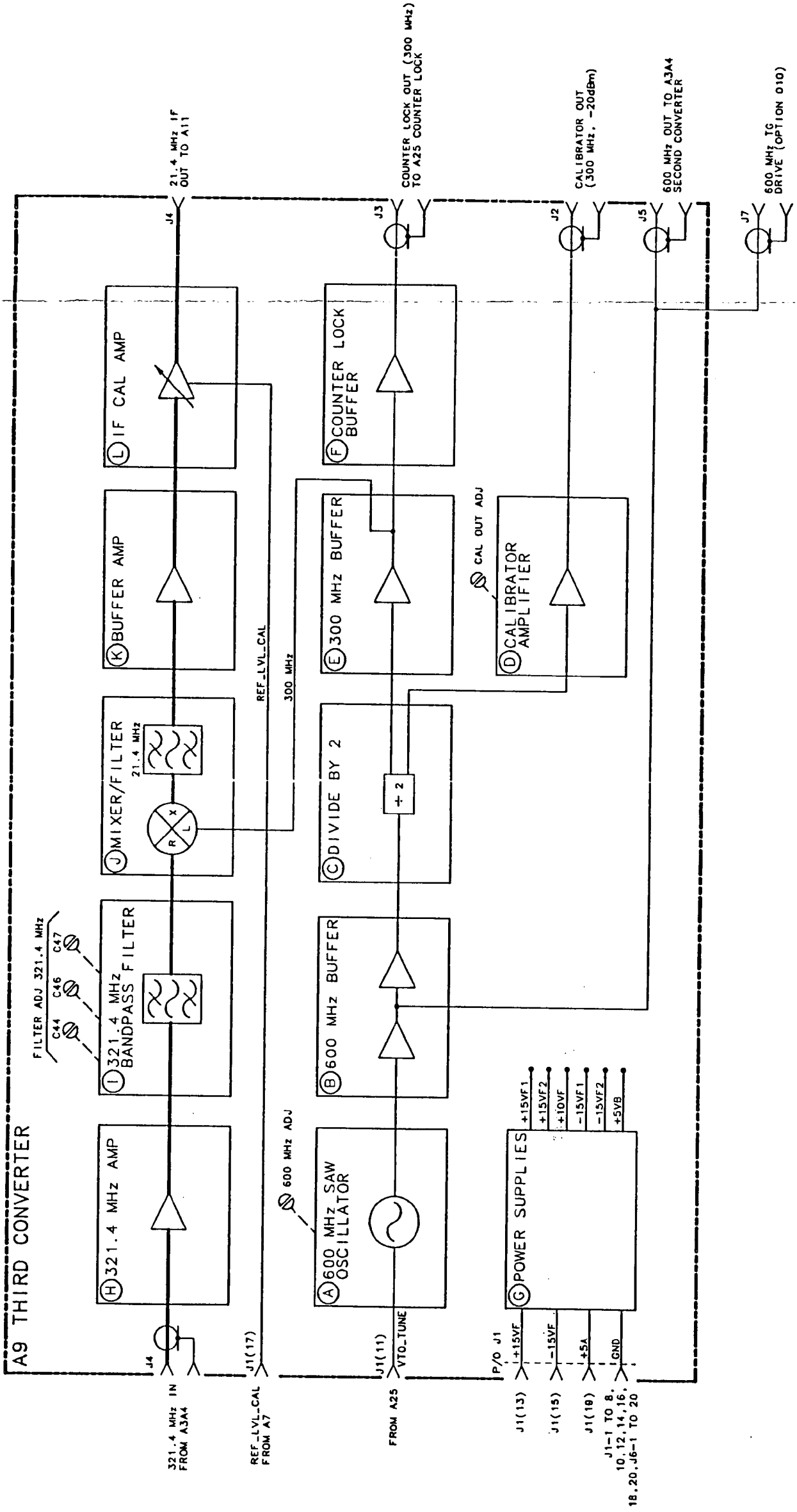

HP 8595A TRACKING GENERATOR CONTROL

A10 TRACKING GENERATOR CONTROL

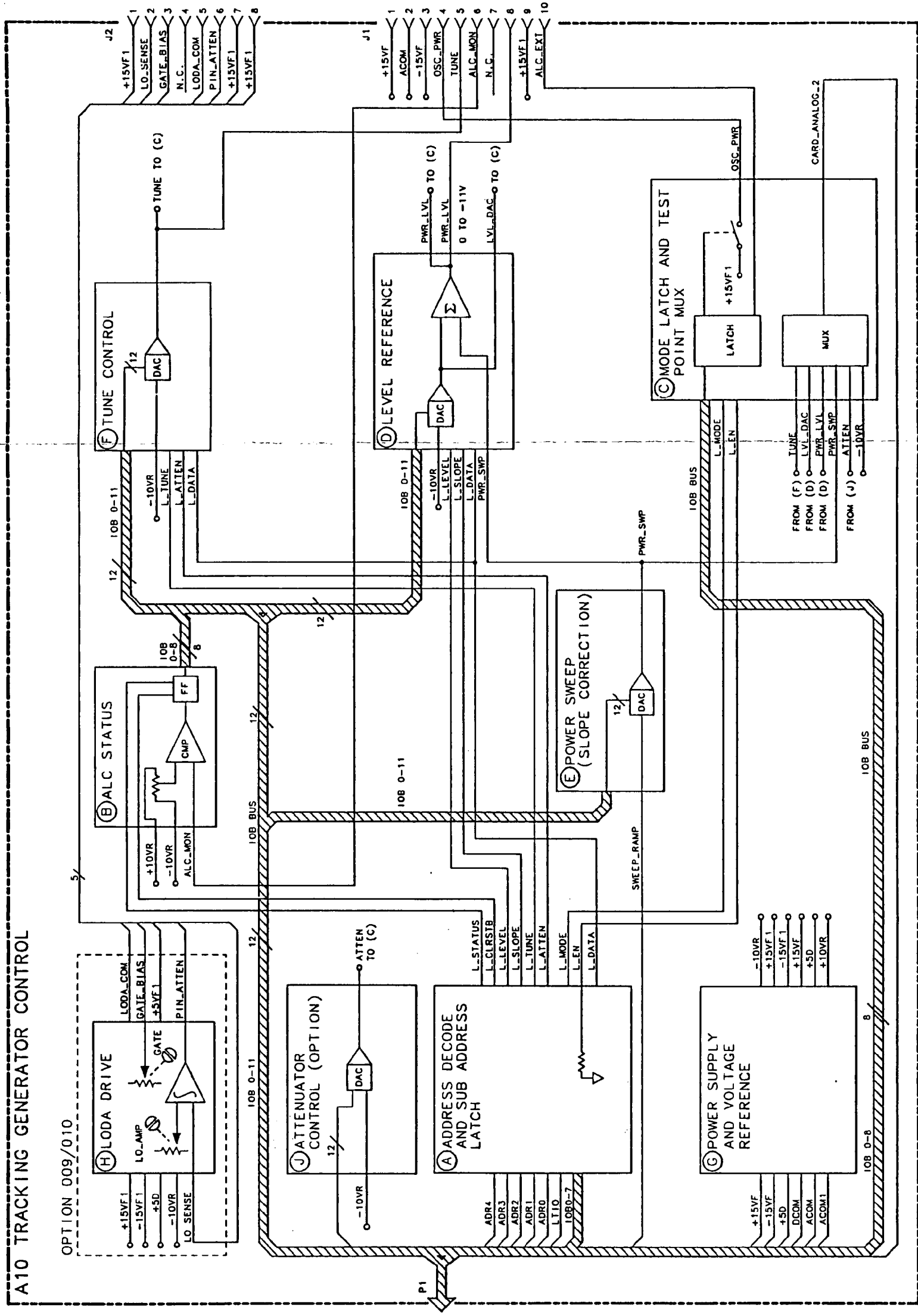

CARD CAGE OPTION

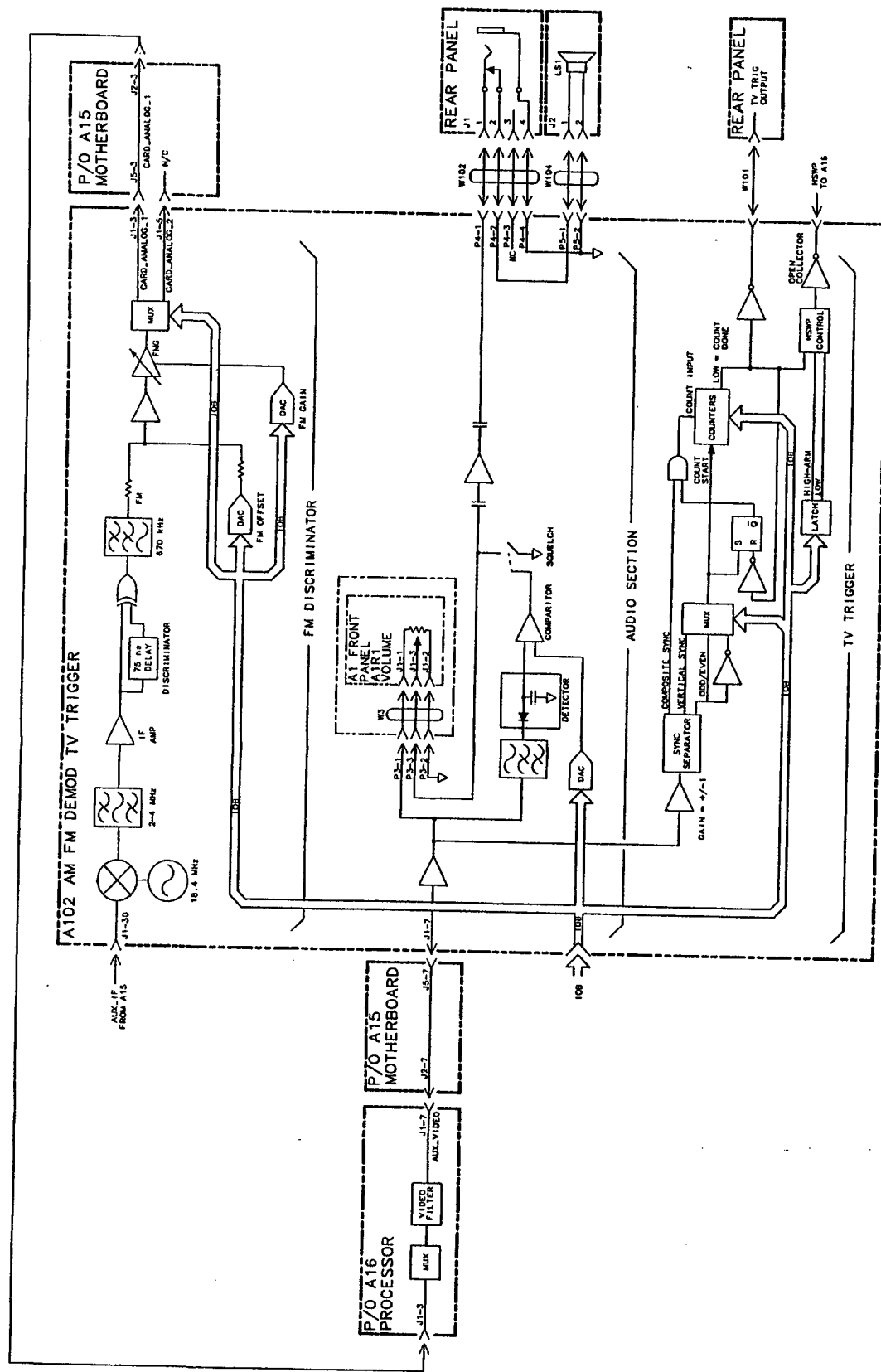

FOLDDOUT 7-6. HP 8555A AM/FM DEMOD TV TRIGGER BLOCK DIAGRAM
RF/LO Section Troubleshooting

CARD CAGE OPTION

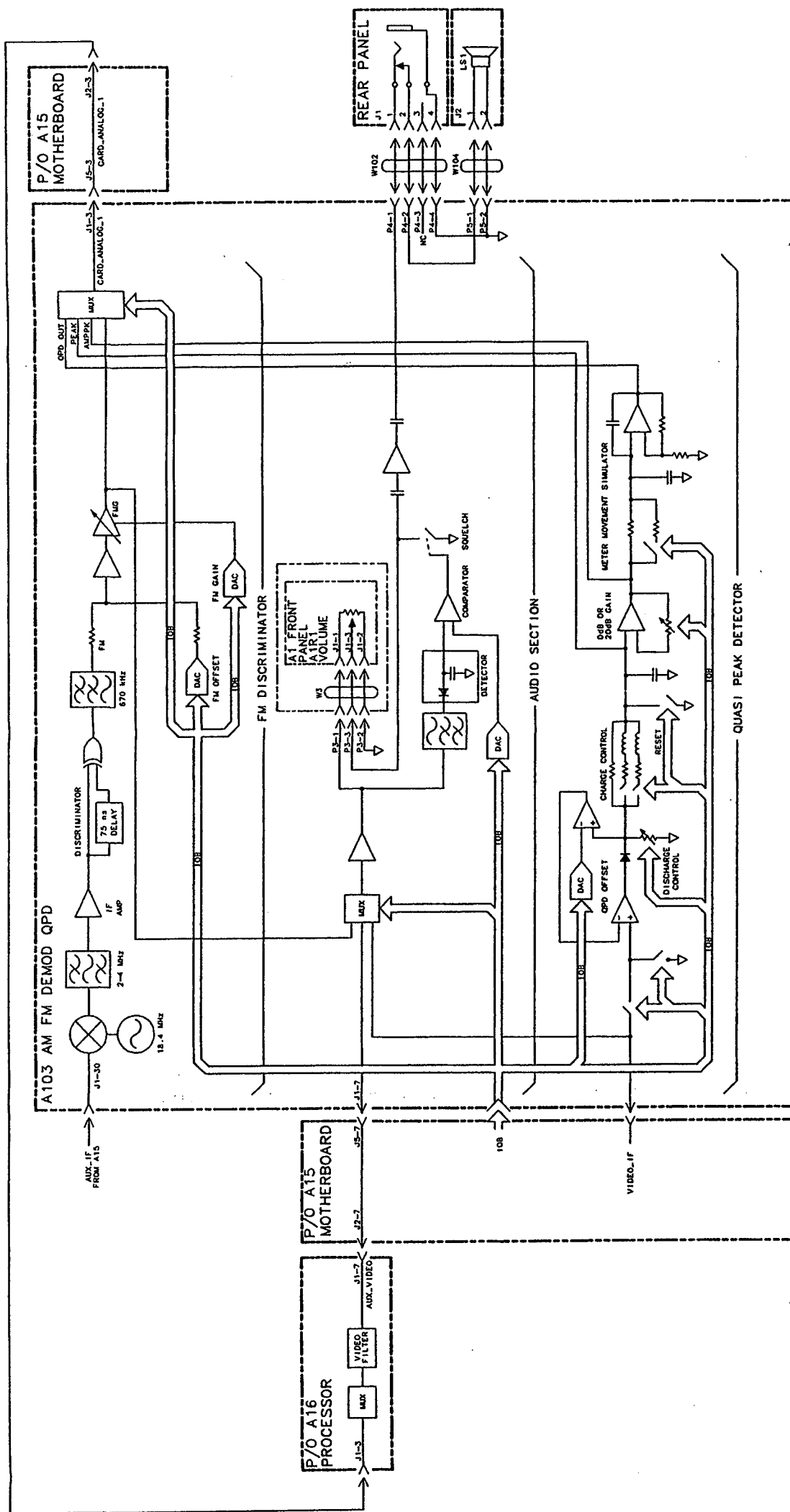

FOLDDOUT 7-7. HP 8595A AM/FM DEMOD QUASI PEAK DETECTOR BLOCK DIAGRAM

IF Section Troubleshooting

Introduction

This chapter provides detailed troubleshooting information for the IF section of the analyzer. Troubleshooting information for tracing signals on A15 Motherboard assembly is also provided.

Refer to Chapter 6 for an overview of analyzer operation and troubleshooting procedures that are useful when first starting to troubleshoot an analyzer failure.

Before You Start Troubleshooting

There are three things you must do *before* you begin troubleshooting an instrument failure:

1. Familiarize yourself with the safety symbols marked on the analyzer, the general safety instructions, and the symbol definitions given in the front of this manual.
2. Read the section entitled "Protection from Electrostatic Discharge" in Chapter 1. The spectrum analyzer contains static-sensitive components.
3. Become familiar with the organization of the troubleshooting information in Chapter 6 and the information in this chapter.

Warning



The analyzer contains potentially hazardous voltages. Refer to the safety symbols on the analyzer and the general safety instructions in this manual before operating the unit with the cover removed. Failure to heed the safety precautions can result in severe or fatal injury.

IF Section Information

This section provides the control details for the assemblies in the IF section. The control-line outputs are valid when the instrument settings provided with each table are used.

For many IF functions, the A7 Analog Interface assembly converts the digital control signals from the A16 Processor/Video assembly to analog control signals. Some analyzer functions are performed directly by the A16 assembly. The A16 assembly also makes amplitude error corrections to improve instrument performance. The analyzer-setting changes and error-correction functions performed on the A16 assembly are a combined mathematical offset of the digitized video signal.

For more information about the A15 Motherboard assembly and the tracing of specific signals in the IF section, refer to "A15 Motherboard Assembly" in this chapter.

Bandwidth Control Lines for the A11/A13 Bandwidth Filter Assemblies

Table 8-1 provides nominal bandwidth control voltages sent to the A11 and A13 Bandwidth Filter assemblies from the A7 Analog Interface assembly. A calibrated analyzer produces control voltages similar to the values in Table 8-1. (The values in Table 8-1 were measured while default calibration data was in use.)

- Use the difference in control voltage between bandwidths from the table as a guide for normal bandwidth operation.
- Use an extender board to measure the bandwidth control voltages at the motherboard connector for the A7 assembly or the A11/A13 filter assemblies.
- Refer to "A15 Motherboard Assembly" for the location of the control lines for each assembly.

Table 8-1. Nominal Resolution Bandwidth Control Line Voltages

Resolution Bandwidth	BW5	BW6	BW7
3 dB			
5 MHz	+14.0	+4.5	+4.4
3 MHz	+14.0	+4.5	+6.4
1 MHz	+14.0	+4.5	+8.5
.3 MHz	+14.0	+4.5	+9.4
.1 MHz	+14.0	+4.5	+9.7
30 kHz	-1.0	+9.7	+9.7
10 kHz	-1.0	+9.5	+9.7
3 kHz	-1.0	+8.9	+9.7
1 kHz	-1.0	+7.3	+9.7
.3 kHz	-1.0	+4.5	+9.7
6 dB EMI			
9 kHz	-1.0	+9.3	+9.7
120 kHz	+14.0	+4.5	+9.6

IF Section Gain Control

Table 8-2 lists the changes in IF Section gain that alter the displayed signal position when the reference level is changed in increments as small as 1 dB. The control voltages from the A7 Analog Interface assembly that change the gain of specific IF assemblies are provided in Table 8-4, Table 8-3, and Table 8-5.

When the reference level is changed, the A16 assembly performs two step-gain functions that change the position of the displayed signal. Refer to Table 8-2 for the reference levels where the A16 assembly changes the signal position in increments of 10 dB. When a reference-level change of less than 1 dB is required, the A16 assembly makes a corresponding change in the signal position. These changes in signal position are made by mathematically offsetting the digitized video signal on the A16 assembly.

The A16 assembly also makes amplitude error corrections to improve instrument performance. The reference-level changes and error-correction functions are a combined mathematical offset of the digitized video signal. This makes it difficult to distinguish which offset is contributing to a change in displayed signal level when the reference level is changed. Disable the error corrections by setting **CORRECTION ON OFF** to Off.

Refer to "A15 Motherboard Assembly" in this chapter when tracing control lines in the IF section.

The entries in Table 8-2 are valid when the following instrument settings are used:

PRESET

Band Lock Band 0
Input Attenuator 10 dB

Table 8-2. IF Section Gain Table in dB

Reference Level (dBm)	A12 Calibration Attenuator (Log/Linear Mode)	A12 Step Gain * (Log/Linear Mode)	A14 Gain (Linear Mode)	A16 Video Offset (Log Mode) †	A16 Video Offset (Linear Mode) †
0	10	0	0	0	0
-1	9	0	0	0	0
-2	8	0	0	0	0
-3	7	0	0	0	0
-4	6	0	0	0	0
-5	5	0	0	0	0
-6	4	0	0	0	0
-7	3	0	0	0	0
-8	2	0	0	0	0
-9	1	0	0	0	0
-10	10	10	0	0	0
-20	10	20	0	0	0
-30	10	30	0	0	0
-40	10	40	0	0	0
-50	10	50	0	0	0
-60	10	50	10	10	0
-70	10	50	20	20	0
-80	10	50	30	30	0
-90	10	50	40	40	0
-100	10	50	40	50	10
-110	10	50	40	60	20
-120	10	50	40	70	30
-130	10	50	40	80	40
-131	9	50	40	80	40
-132	8	50	40	80	40
-133	7	50	40	80	40
-134	6	50	40	80	40
-135	5	50	40	80	40
-136	4	50	40	80	40
-137	3	50	40	80	40
-138	2	50	40	80	40
-139	1	50	40	80	40

* The gain of the 10 dB step-gain stage is 15 dB when enabled and 5 dB when disabled.

† Turn **CORRECT ON OFF** off to remove the amplitude error corrections generated by **CAL AMP TD**.

Control Lines for the A12 Amplitude Control Assembly

Table 8-3 and Table 8-4 provide the control line output from the A7 Analog Interface assembly that change the gain of the A12 assembly when the reference level is changed. The Calibration Attenuator settings in Table 8-4 provide reference-level changes in 1 dB increments for the full reference-level range of the analyzer.

Refer to "A15 Motherboard Assembly" in this chapter when tracing control lines in the IF section.

The entries in Table 8-3 and Table 8-4 are valid when the instrument is set up as follows:

PRESET

Band Lock Band 0
 Input Attenuator 10 dB

Table 8-3. 10 dB Step-Gain Control Lines

Reference Level (dBm)	10 dB Step Gains	IFG1 (10 dB Step)	IFG2 (20-1 dB Step)	IFG3 (20-2 dB Step)
0	0	L	L	L
-10	10	H	L	L
-20	20	L	H	L
-30	30	H	H	L
-40	40	L	H	H
-50	50	H	H	H

H = >2.5 V (TTL High)
 L = <0.8 V (TTL Low)

For each reference level in Table 8-3, the Calibration Attenuator control lines are set to 10 dB of attenuation as shown in the first entry of Table 8-4. The control line settings from Table 8-4 repeat, starting with each reference level in Table 8-3 to produce reference-level changes in 1 dB increments.

Table 8-4. Calibration-Attenuator Control Lines

Reference Level (dBm)	Calibration Attenuator	IFA1 (1 dB)	IFA2 (2 dB)	IFA3 (4 dB)	IFA4 (8 dB)	IFA5 (16 dB)
0	10	L	H	L	H	L
-1	9	H	L	L	H	L
-2	8	L	L	L	H	L
-3	7	H	H	H	L	L
-4	6	L	H	H	L	L
-5	5	H	L	H	L	L
-6	4	L	L	H	L	L
-7	3	H	H	L	L	L
-8	2	L	H	L	L	L
-9	1	H	L	L	L	L

H = >2.5 V (TTL High)
 L = <0.8 V (TTL Low)

Linear Gain Control Lines for A14 Log Amplifier

Table 8-5 provides the control line voltages from A7 Analog Interface assembly to the A14 Log Amplifier assembly. When the analyzer is in linear mode, the seven A14 log amplifier stages are biased to operate as linear amplifiers. Four of the seven stages are also used to provide 40 dB of gain in 10 dB increments. The linear gains are enabled for the reference levels indicated in Table 8-2 and Table 8-5. Two of the four stages operate as one 20 dB amplifier and are controlled by the same control line, IFG6.

Refer to "A15 Motherboard Assembly" in this chapter when tracing control lines in the IF section.

Note



When enabled, each control line has a -7.6 V dc output. This voltage is supplied by the -8 VT temperature-compensated power supply located on the A14 assembly.

The entries in Table 8-5 are valid when the instrument is set up as follows:

PRESET

Band Lock Band 0
 Input Attenuator 10 dB
~~SCALE LOG LIN~~ Linear

Table 8-5. Linear Gain Control Lines on the A14 Assembly

Reference Level (dBm)	A14 Gain in Linear Mode (dB)	IFG4 (10-1 dB Step)	IFG5 (10-2 dB Step)	IFG6 (20 dB Step)
-50	0	H	H	H
-60	10	L	H	H
-70	20	L	L	H
-80	30	L	H	L
-90	40	L	L	L

H = +14.3 V dc (disabled)
 L = -7.6 V dc (enabled)

A15 Motherboard Assembly

Use this section to identify and locate all the signals and voltages that pass through the A15 Motherboard assembly. The location of active components on the motherboard are also provided.

The following information is provided in this section:

- Figure 8-1, A15 Motherboard Connector Designation. Shows the location and reference designator for each connector on the motherboard.
- Figure 8-2, A15 Connectors with Additional Associated Circuitry. Provides a simplified circuit diagram for the components on the motherboard. To help locate the components, the motherboard connector-pin that is connected to each component is shown.
- Figure 8-3, A15J13 Connector-Pin Designation. Provides the pin numbering sequence for the connector that connects the AS Power Supply to the motherboard.
- Figure 8-4, Card-Cage Connector Pin Designation. Provides the pin-numbering sequence for the four motherboard connectors in the card cage. The motherboard connector for the A7 Analog Interface assembly (not shown) has the same pin-numbering sequence, but is installed in a position that is reversed when compared to the card-cage connectors.
- Table 8-6, A15 Motherboard Mnemonic Descriptions. Provides the mnemonic, full name, and functional description for each signal and voltage on the motherboard.
- Table 8-7, A15 Motherboard Pin Designations. Identifies the signal or voltage distribution for each signal and voltage on the motherboard.

Each column identifies the instrument assembly that is connected to the A15 motherboard. The associated motherboard reference designator for each assembly is also supplied.

The mnemonics from Table 8-6 are arranged alphabetically by row on the left-hand side of the table.

For a given mnemonic, read across the row to find all the assemblies that the signal or voltage is connected to. The A15 connector pin numbers in each box indicate the A15 connector pins where the signal or voltage appear.

Be sure to read the footnotes at the bottom of Figure 8-1.

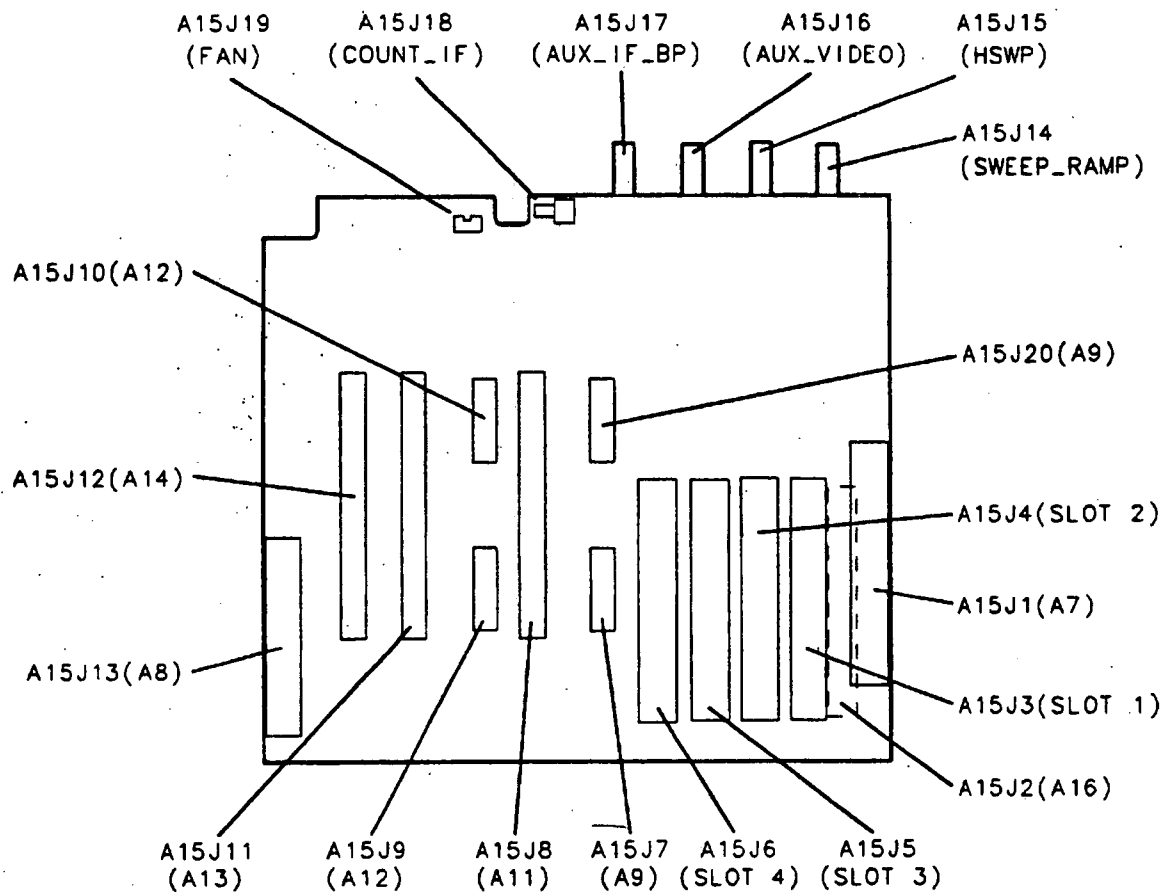

Figure 8-1. A15 Motherboard Connector Designation

- All connector pins on A9J20 are tied to ground (ACOM).
- The A15J1 connector for the A7 Analog Interface assembly is installed in a position that is reversed when compared to card-cage connectors A15J3, A15J4, A15J5, and A15J6; therefore, the pin-numbering order is also reversed for A15J1 when compared to the card-cage connectors.

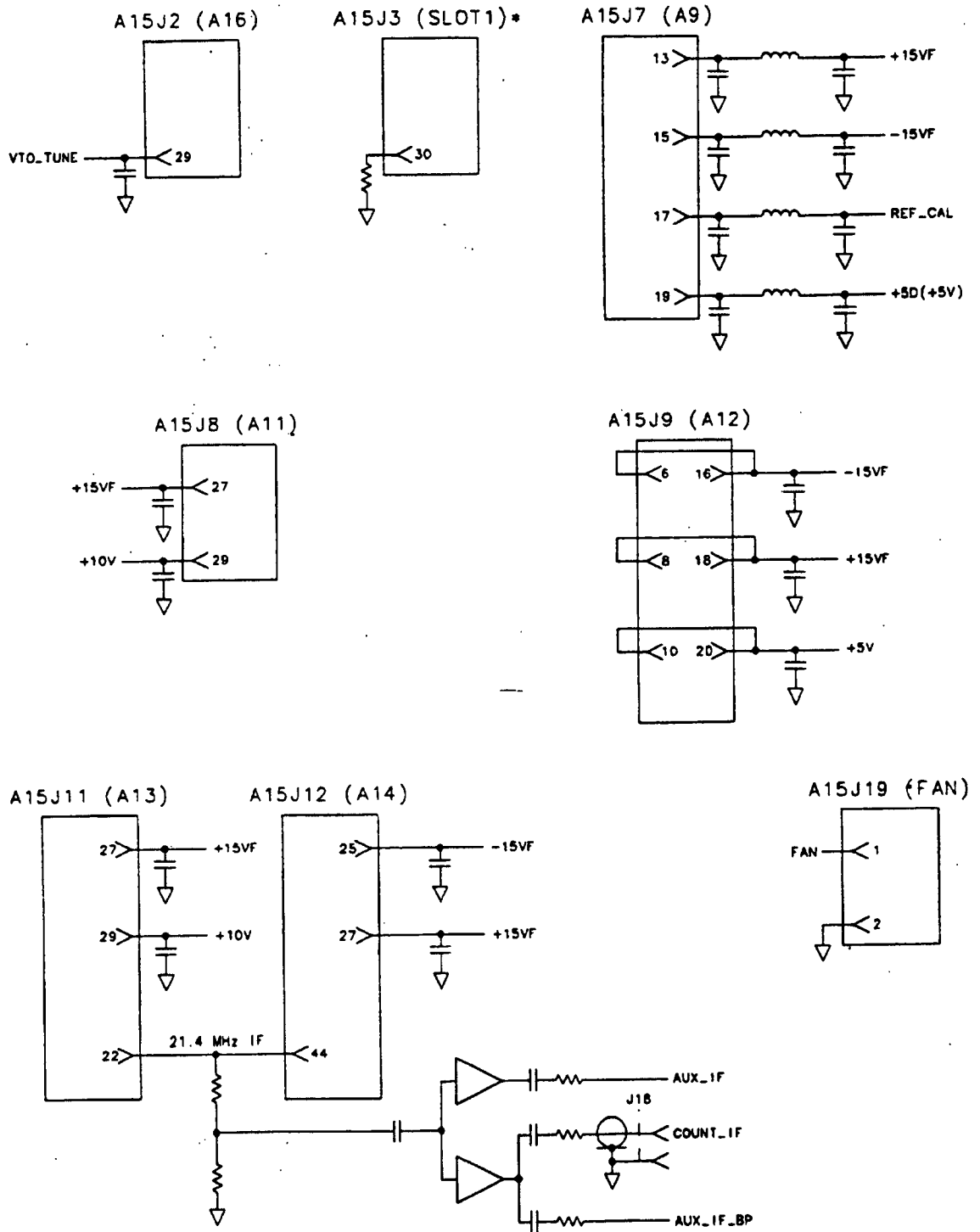
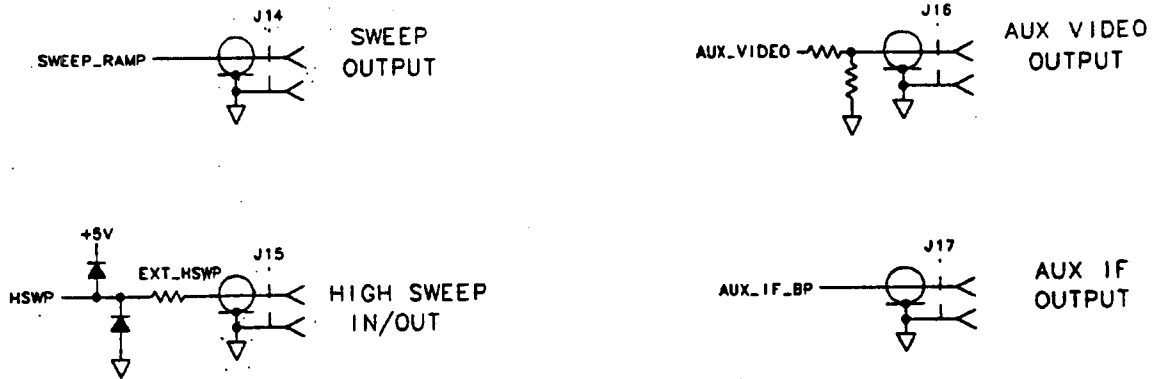

Figure 8-2. A15 Connectors with Additional Associated Circuitry (1 of 2)

REAR FRAME CONNECTORS



A15 Connectors with Additional Associated Circuitry (2 of 2)

- The A15 Motherboard pin designation for the 21.4 MHz IF signal path is provided on Foldout 6-2, IF/Control Overall Block Diagram, and in Table 8-7.
- All the connector pins with the same number are connected in parallel for the card-cage connectors A15J3, A15J4, A15J5, and A15J6.

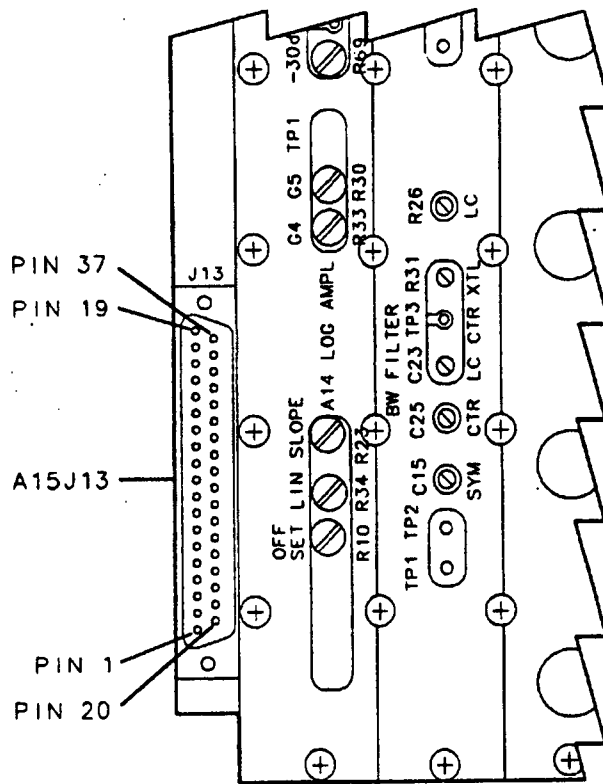

Figure 8-3. A15J13 Connector-Pin Designation

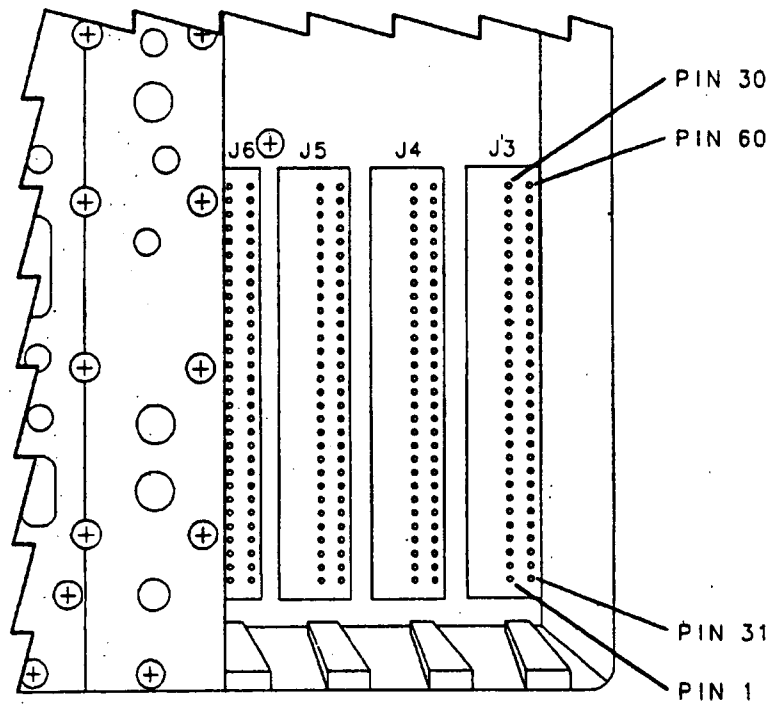

Figure 8-4. Card-Cage Connector Pin Designation

Table 8-6. A15 Motherboard Mnemonic Descriptions

Mnemonic	Full Name	Description
21.4 MHz IF	21.4 MHz IF	The 21.4 MHz IF signal between the A9 Third Converter assembly and the detector on the A14 Log Amplifier assembly.
+10V	+10 V Supply	The A7 Analog assembly provides a +10 V bias supply for the LC bandwidth filters on the A11/A13 Bandwidth Filter assemblies.
+12V	+12 V Supply	+12 V supply for the A2 Display and the RS-232 option, referenced to DCOM.
+15VF	+15 V Supply	+15 V power supply, referenced to ACOM.
+5V	+5 V Supply	+5 V power supply, referenced to DCOM.
-15V	-15 V Supply	-15 V power supply, referenced to ACOM.
-8VT	-8 V Temperature Compensated Supply	Provides -8 V from the temperature-compensated (TC) power supply on the A14 Log Amplifier assembly to the A7 Analog Interface assembly. The A7 provides temperature-compensation for the IFG4-IFG6 and the Log/Lin control lines using the -8 VT as a TC reference.
ACOM	Analog Common	A common ground for all analog circuitry.
ADC_SYNC	A/D Conversion Synchronization	A positive-going signal that indicates when the main ADC on the A16 Video/Processor assembly has started a A/D conversion. ADC_SYNC resets the peak detectors located on assemblies installed in the HP8591A/93A card cage.
ADR0-ADR4	Address 0-4	Input/Output (IO) address lines.
ANA_TEST	Analog Test	Provides a series of test signals from A7 Analog Interface assembly to A16 Processor/Video assembly during instrument calibration and troubleshooting. (Refer to the A7 Overview Section)
AUX_IF	Auxiliary IF	An uncorrected, buffered 21.4 MHz IF signal from the output of the A13 Bandwidth Filter assembly to the four card-cage slots.
AUX_IF_BP	Auxiliary IF Back Panel	A uncorrected, buffered 21.4 MHz IF signal from the output of the A13 Bandwidth Filter assembly to J17, AUX IF OUTPUT.
AUX_VIDEO	Auxiliary Video	A detected video signal (0—2 V) that has passed through the video filters. No amplitude corrections have been applied to this signal. A voltage divider at J16, AUX VIDEO OUTPUT, reduces the signal amplitude to 0—1 V.

Mnemonic	Full Name	Description
BW5	Bandwidth 5	A bias voltage that activates either the LC or crystal bandwidth-filter mode.
BW6	Bandwidth 6	Controls the crystal-filter bandwidth.
BW7	Bandwidth 7	Controls the LC filter bandwidth.
COUNT_IF	Counterlock IF	A buffered 21.4 MHz IF signal from the output of the A13 Bandwidth Filter assembly to A25 Counter-Lock assembly.
CRD_ANLG.1	Card Cage Analog 1	An analog signal from assemblies installed in the card cage to the A16 input multiplexer. When it is selected, the signal passes through the A16 video-filter and peak-detector sections. It is available on AUX_VIDEO after it passes through the video filter.
CRD_ANLG.2	Card Cage Analog 2	An analog signal from assemblies installed in the card cage. The signal goes directly to A16 A/D conversion section, bypassing both the video-filter and peak-detector sections.
DCOM	Digital Common	A common ground for all digital circuitry.
DISCRIM or DISCRIMINATOR	Discriminator	For Spans ≤ 10 MHz, the A25 Counter-Lock assembly sends a dc tuning voltage through the A16 Processor/Video assembly to the A7 Analog Interface assembly. The A7 assembly then adjusts the YTO to reduce residual FM.
EXT_HSWP	External High Sweep	EXT.HSWP performs two functions: 1) It provides external control of high sweep on the A16 Processor/Video when an external signal is connected to J15, HIGH SWEEP INPUT/OUTPUT. 2) It provides the HSWP signal as a rear-panel output at J15, HIGH SWEEP INPUT/OUTPUT. <i>This is an open-collector signal. It should never be driven high.</i>
FAN	FAN	+12 V power supply for the B1 Fan.
HPWRUP	High Power Up	Enables the initial start-up sequence for the CPU on the A16 Processor/Video assembly when the analyzer is first turned on. This occurs prior to the start-up of other related assemblies.
HSWP	High Sweep	Provides control for the analyzer display sweep and retrace. A TTL high starts a sweep and a TTL low initiates a retrace. <i>This is an open-collector signal. It should never be driven high.</i>

Mnemonic	Full Name	Description
IFA1	IF Attenuation 1	Control line for 1dB step attenuator on the A12 Amplitude Control assembly.
IFA2	IF Attenuation 2	Control line for the 2 dB step attenuator on the A12 Amplitude Control assembly.
IFA3	IF Attenuation 3	Control line for the 4 dB step attenuator on the A12 Amplitude Control assembly.
IFA4	IF Attenuation 4	Control line for the 8 dB step attenuator on the A12 Amplitude Control assembly.
IFA5	IF Attenuation 5	Control line for the 16 dB step attenuator on the A12 Amplitude Control assembly.
IFG1	IF Gain 1	Control line for the 10 dB step gain on the A12 Amplitude Control assembly.
IFG2	IF Gain 2	Control line for the first 20 dB step gain on the A12 Amplitude Control assembly.
IFG3	IF Gain 3	Control line for the second 20 dB step gain on the A12 Amplitude Control assembly.
IFG4	IF Gain 4	Temperature-compensated control line for the 10 dB linear gain on the A14 Log Amplifier assembly.
IFG5	IF Gain 5	Temperature-compensated control line for the 10 dB linear gain on the A14 Log Amplifier assembly.
IFG6	IF Gain 6	Temperature-compensated control line for the 20 dB linear gain on the A14 Log Amplifier assembly.
INTERBUS	Interbus	A communication line between the four slots in the card cage. It coordinates functions between options when more than one option is installed in the card cage.
IOB0-IOB15	Input/Output Bus 0- Input/Output Bus 15	Input/Output (IO) data lines used between the A16 Processor/Video assembly and related assemblies.
LBIO	Low Bottom-box Input/Output	Strobe line for Input/Output (IO) data transfers.
LINE_TRIG	Line Trigger	Provides a TTL signal at the power-line frequency rate. It enables the line-trigger mode on the A16 Processor/Video assembly.
LOG_LIN	Log Linear	Controls switching between log and linear modes on the A14 Log Amplifier assembly.

Mnemonic	Full Name	Description
LPWRON	Low Power On	The front-panel line switch provides a TTL low when the switch is depressed. This initiates start-up of the A8 Power Supply and A16 Processor/Video assemblies.
LTIO	Low Top-box Input/Output	Strobe line for Input/Output (I/O) data transfers.
REF.CAL	Reference Cal	A DAC on the A7 Analog Interface assembly adjusts the gain of the A9 Third Converter assembly through REF.CAL. (Refer to A7 Analog Interface assembly Overview section)
SWEEP_RAMP	Sweep Ramp	A 0 to +10 V ramp signal that corresponds to signal sweep across the display. The signal is sent to J14, SWEEP OUTPUT, on the rear frame.
VIDEO.IF	Video IF	The detected 21.4 MHz IF signal from the detector on the A14 Log Amplifier assembly to the input multiplexer on the A16 Processor/Video assembly.
VTO.TUNE	Voltage-Tuned Oscillator Tune	A tuning voltage from the A25 Counter-Lock assembly to A9 Third Converter assembly. It locks the 600 MHz oscillator on the A9 assembly to the frequency reference.

Table 8-7. A15 Motherboard Pin Designations

Mnemonic	Instrument Assemblies										Card Cage
	A7 A15J1	A8 A15J13	A9 A15J7	A11 A15J8	A12 A15J9	A12 A15J10	A13 A15J11	A14 A15J12	A16 A15J2		
21.4 MHz IF			9	22, 23	1	20	22, 23	#			Slots 1,2,3,4 A15J3,4,5,6
+10 V	22 *			29			29	#			
+12 V		13, 32 *							27, 57		
+15 V	3, 33	1, 2, 3 *	#	27	8, 18		27	#	8, 38		9, 39
+5 V	19, 49	9,10,11,12 *	#		10, 20				25, 26, 55, 56		26, 56
-15 V	4, 34	4, 5, 6 *	#		6, 16	#			9, 39		10, 40
-8 VT	23							8 *			
ACOM	2, 32	7, 26, 27	1-8, 10, 12, 14, 16, 18, 20	1-21, 24-26, 28, 33-44	2-5, 7, 9, 11-15, 17, 19	5-10, 15-19	1-21, 24-26, 28, 33-44	1, 3-7, 9-24, 26, 28-30, 32-37, 41-43	2, 4, 6, 32-37		2, 4, 6, 8 29, 31-38, 59, 60
ADC_SYNC									30 *		27
ADRO	6								11 *		12
ADR1	36								41 *		42
ADR2	7								12 *		13

* Pin numbers indicate assembly where signal or voltage originates.

Refer to the figure, "A15 Connectors with Additional Associated Circuitry" in this section

Table 8-7. A15 Motherboard Pin Designations (continued)

Mnemonic	Instrument Assemblies													Card Cage
	A7 A15J1	A8 A15J13	A9 A15J7	A11 A15J8	A12 A15J9	A12 A15J10	A13 A15J11	A14 A15J12	A16 A15J2					
ADR3	37								42	*				43
ADR4	8								13	*				14
ANA_TEST	31								31	*				
AUX_IF							22	**						30
AUX_IF_BP							22	**						
AUX_VIDEO									7	*				7
BW5	24	*		30			30							
BW6	54	*		31			31							
BW7	25	*		32			32							
COUNT_IF														
CRD_ANLG_1									3	*				3
CRD_ANLG_2									5	*				5

* Pin numbers indicate assembly where signal or voltage originates.
 # Refer to the figure, "A15 Connectors with Additional Associated Circuitry" in this section.

Table 8-7. A15 Motherboard Pin Designations (continued)

Mnemonic	Instrument Assemblies										Card Cage
	A7 A15J1	A8 A15J13	A9 A15J7	A11 A15J8	A12 A15J9	A12 A15J10	A13 A15J11	A14 A15J12	A16 A15J2	A16 A15J2	
DCOM	11, 16, 35, 38 43, 48	14-17, 33-36							16, 21, 40 43, 48, 53	17, 22, 41 44, 49, 54	Slots 1,2,3,4 A15J3,4,5,6
DISCRIMI- NATOR	21								*		
EXT_HSWP	#										
FAN #		8 *									
HPWRUP	50	37 *							54	55	
HSWP #									58 *	57	
IFA1	58 *					4					
IFA2	29 *					3					
IFA3	59 *					2					
IFA4	30 *					1					
IFA5	60 *					11					
IFG1	55 *					14					

* Pin numbers indicate assembly where signal or voltage originates.
Refer to the figure, "A15 Connectors with Additional Associated Circuitry" in this section.

Table 8-7. A15 Motherboard Pin Designations (continued)

Mnemonic	Instrument Assemblies										Card Cage
	A7 A15J1	A8 A15J13	A9 A15J7	A11 A15J8	A12 A15J9	A12 A15J10	A13 A15J11	A14 A15J12	A16 A15J2	A16 A15J2	
IFG2	26 *					13					Slots 1,2,3,4 A15J3,4,5,6
IFG3	56 *					12					
IFG4	27 *						38				
IFG5	57 *						39				
IFG6	28 *						40				
INTERBUS											58 #
IOB0	9								14		15
IOB1	39								44		45
IOB2	10								5		16
IOB3	40								45		46
IOB4	41								46		47
IOB5	12								17		18

* Pin numbers indicate assembly where signal or voltage originates.
Refer to the figure, "A15 Connectors with Additional Associated Circuitry" in this section.

Table 8-7. A15 Motherboard Pin Designations (continued)

Mnemonic	Instrument Assemblies										Card Cage
	A7 A15J1	A8 A15J13	A9 A15J7	A11 A15J8	A12 A15J9	A12 A15J10	A13 A15J11	A14 A15J12	A16 A15J2	A16 A15J3, 4, 5, 6	
IOB6	42								47	48	
IOB7	13								18	19	
IOB8	14								19	20	
IOB9	44								49	50	
IOB10	15								20	21	
IOB11	45								50	51	
IOB12	46								51	52	
IOB13	17								22	23	
IOB14	47								52	53	
IOB15	18								23	24	
LBIO	5								*	*	11
LINE_TRIG		18	*							60	

* Pin numbers indicate assembly where signal or voltage originates.

Refer to the figure. *A15 Connectors with Additional Associated Circuitry* in this section.

Table 8-7. A15 Motherboard Pin Designations (continued)

Mnemonic	Instrument Assemblies										Card Cage
	A7 A15J1	A8 A15J13	A9 A15J7	A11 A15J8	A12 A15J9	A12 A15J10	A13 A15J11	A14 A15J12	A16 A15J2	A16 A15J2	
LOG_LIN	52 *							31			Slots 1,2,3,4 A15J3,4,5,6
LPWRON		19							59 *		
LTIO									24 *		25
REF_CAL	53 *		#								
SWEEP_RAMP	51 *										28
VIDEO_IF								2 *	1		1
VTO_TUNE			11						29 **	#	

* Pin numbers indicate assembly where signal or voltage originates.
 # Refer to the figure, "A15 Connectors with Additional Associated Circuitry" in this section.

Control/Display Section Troubleshooting

Introduction

This chapter provides detailed procedures for safe-guarding the correction data stored in RAM on the A16 Processor/Video assembly, and resetting the spectrum analyzer memory after a repair or replacement of the A16 assembly. Troubleshooting information for the A7 Analog Interface assembly is also included.

Commands within parenthesis after a softkey, for example (LOG), are used throughout this chapter to indicate the part of a softkey which should be underlined when the key is pressed.

Refer to Chapter 6 for an overview of spectrum analyzer operation and troubleshooting procedures that are useful when starting to troubleshoot a spectrum analyzer failure.

Before You Start Troubleshooting

There are three things you must do *before* you begin troubleshooting an instrument failure:

- Familiarize yourself with the safety symbols marked on the spectrum analyzer, and read the general safety instructions and the symbol definitions given in the front of the Service Manual.
- The spectrum analyzer contains static sensitive components. Read the section entitled "Protection From Electrostatic Discharge".
- Become familiar with the organization of the troubleshooting information in Chapter 6 and the information in this chapter.

Warning



The spectrum analyzer contains potentially hazardous voltages. Refer to the safety symbols on the spectrum analyzer and the general safety instructions in this manual before operating the unit with the cover removed. Failure to heed the safety precautions can result in severe or fatal injury.

Backing Up Spectrum Analyzer Correction Constants

This section describes how to retrieve the correction-constant data from the instrument memory and record the data as a backup copy. As long as the data remains valid it can be used to recalibrate the instrument quickly after a memory loss. It is recommended that a copy of this data be maintained in the user's records. Procedures for restoring the correction constants to battery-backed RAM memory are also provided in this section.

Note



If the current correction constants are not valid, new correction constants must be generated. Refer to the "10 MHz Reference (Standard)," "Frequency Response," and "Cal Attenuator Error Correction" adjustment procedures in Chapter 2.

The HP 8595A stores the following correction constants in RAM:

- The flatness correction constants, used to correct frequency-response amplitude errors.
- The step-attenuation correction constants, used to correct A12 Amplitude Control step-attenuator errors and provide a relative amplitude reference for the **CAL AMPTD** self-calibration routine.
- The timebase correction constant, used by the DAC that tunes the RTXO (10 MHz timebase) on the A25 Counter Lock assembly. Instruments with Option 004, Precision Frequency Reference, do not use this correction constant.

Retrieving the Timebase and Flatness-Correction Constants

1. Make a copy of the Correction Constant Backup-Data Record, Table 9-1 through Table 9-4, at the end of this section.
2. Record the date and instrument serial number.
3. Press the following keys:

PRESET

FREQUENCY -37 **Hz**

CAL **MORE 1 of 3** **MORE 2 of 3**

Note



For Option 004 instruments, bypass the next two steps.

4. Press **VERIFY TIMEBASE**.
5. Record the number that is displayed in the active-function block in Table 9-1.

6. Press the following keys:

SERVICE CAL

FLATNESS DATA

EDIT FLATNESS

7. The signal trace represents the frequency-response (flatness) correction-constant data. The active-function block displays the frequency response error, in dB, for 12 MHz.
8. Record the frequency-response error for 12 MHz in Table 9-2.
9. Press **↑**.

Note



There is an overlap in the frequency data between bands. For example, near the edge of band 0 and band 1, the frequencies displayed will be 2.820, 2.892, 2.7500, and 2.9849 GHz.

- The data for 2.820 and 2.892 GHz is for band 0.
- The data for 2.7500 and 2.9849 GHz is for band 1.

10. Record the next frequency-response error in Table 9-2.
11. Repeat the previous two steps until all frequency-response errors are recorded in Table 9-2 through Table 9-3. Use **↓** to view previous data points.
12. Press **EXIT** when all frequency-response errors have been recorded.

Retrieving the A12 Step-Gain-Correction Constants

1. Press the following keys to view the current A12 step-attenuator correction constants.

CAL MORE 1 of 3 MORE 2 of 3

SERVICE DIAG

DISPLAY CAL DATA

2. Look at the first five entries in the ERR column; they are the amplitude errors for the 1 dB, 2 dB, 4 dB, 8 dB, and 16 dB step-attenuators.
3. Record the amplitude errors (correction constants) for the five step-attenuators in Table 9-4.

File the completed copy of the Correction-Constant Data Record for future reference.

Correction Constant Backup-Data Record

Hewlett-Packard Company	
Model HP 8595A	
Serial No. _____	Date _____

**Table 9-1.
RTXO Timebase Correction Constant (Instruments without Option 004)**

Timebase	_____
----------	-------

Table 9-2. Frequency-Response Correction Constants—Band 0

Frequency (GHz)	Error (dB)	Frequency (GHz)	Error (dB)	Frequency (GHz)	Error (dB)	Frequency (GHz)	Error (dB)
0.012	_____	0.804	_____	1.596	_____	2.388	_____
0.084	_____	0.876	_____	1.668	_____	2.460	_____
0.156	_____	0.948	_____	1.740	_____	2.532	_____
0.228	_____	1.020	_____	1.812	_____	2.604	_____
0.300	_____	1.092	_____	1.884	_____	2.676	_____
0.372	_____	1.164	_____	1.956	_____	2.748	_____
0.444	_____	1.236	_____	2.028	_____	2.820	_____
0.516	_____	1.308	_____	2.100	_____	2.892	_____
0.588	_____	1.380	_____	2.172	_____		_____
0.660	_____	1.452	_____	2.244	_____		_____
0.732	_____	1.524	_____	2.316	_____		_____

Correction Constant Backup-Data Record

Hewlett-Packard Company	
Model HP 8595A	
Serial No. _____	Date _____

Table 9-3. Frequency-Response Correction Constants—Band 1

Frequency (GHz)	Error (dB)	Frequency (GHz)	Error (dB)	Frequency (GHz)	Error (dB)	Frequency (GHz)	Error (dB)
2.7500	_____	3.9245	_____	5.0990	_____	6.2735	_____
2.9849	_____	4.1594	_____	5.3339	_____	6.5084	_____
3.2198	_____	4.3943	_____	5.5688	_____		
3.4547	_____	4.6292	_____	5.8037	_____		
3.6896	_____	4.8641	_____	6.0386	_____		

Table 9-4. A12 Step-Attenuator Correction Constants

Attenuator Step	ERR (dB)	Attenuator Step	ERR (dB)
1 dB	_____	4 dB	_____
2 dB	_____	8 dB	_____
		16 dB	_____

A16 Memory Reset

Note



Before performing a memory reset, check the status LEDs on the A16 assembly at instrument power-up. If the A16 LEDs, DS1 through DS16, do not cycle on and off at power-up, there is a problem with the A16 central processing unit (CPU) that a memory reset will not correct. (It is normal for DS13 to remain on after pressing **PRESET**.)

The A16 memory may contain erroneous information that causes the A16 CPU to malfunction. The following are possible memory-failure symptoms.

- A random display periodically flashes on-screen. Refer to the "Symptoms of a Dead Battery" section in this chapter.
- Following instrument preset, the error message FAIL: 0330 000000000 is displayed. Refer to the "Symptoms of a Dead Battery" section in Chapter 6.
- The spectrum analyzer halts during power-up or when **PRESET** is used.

A CPU malfunction can be caused by a user's accidentally writing to a sensitive memory location or by a defective down-loadable program (DLP). The spectrum analyzer may also appear to be defective because the CPU is making extreme instrument corrections based on erroneous calibration data.

Performing an A16 Memory Reset

There are three levels of memory reset; each level has a greater effect on the instrument memory.

1. Before doing a memory reset, enter the -37 Hz passcode and use **DEFAULT CAL DATA** to bypass the current calibration data.
 - If the instrument functions properly, recalibrate it using the self-calibration routines.
 - If the instrument still does not function properly, continue with the next level of memory reset.
2. Use **DISPOSE USER MEMORY** to eliminate all programs stored in user memory.

All down-loaded programs (DLPs) that are stored in user memory must be reloaded after using this function.

Refer to the *HP 8594A/8595A Installation and Verification Manual* for information about **DISPOSE USER MEMORY**.

Caution



The following memory-reset procedure is the most extreme level of memory reset. It should be performed only if all other attempts at solving the problem have failed. A memory reset will delete all the correction constants stored in RAM. New correction constants must be generated if the original correction constants were not saved before the spectrum analyzer failed.

Use the procedures in "Backing Up the Correction Constants" to retrieve the correction constants.

3. Use the following procedure to erase all RAM memory. This procedure disables the battery-backed RAM by shorting the holding capacitor, C106, that is in parallel with the BT101 Battery.
 1. Turn the spectrum analyzer off and disconnect line power.
 2. Remove the instrument cover. Refer to the instrument cover removal procedure in Chapter 3.
 3. Position the spectrum analyzer so that the bottom side is facing up.
 4. Locate U104 on the A16 assembly. Refer to Figure 9-1.

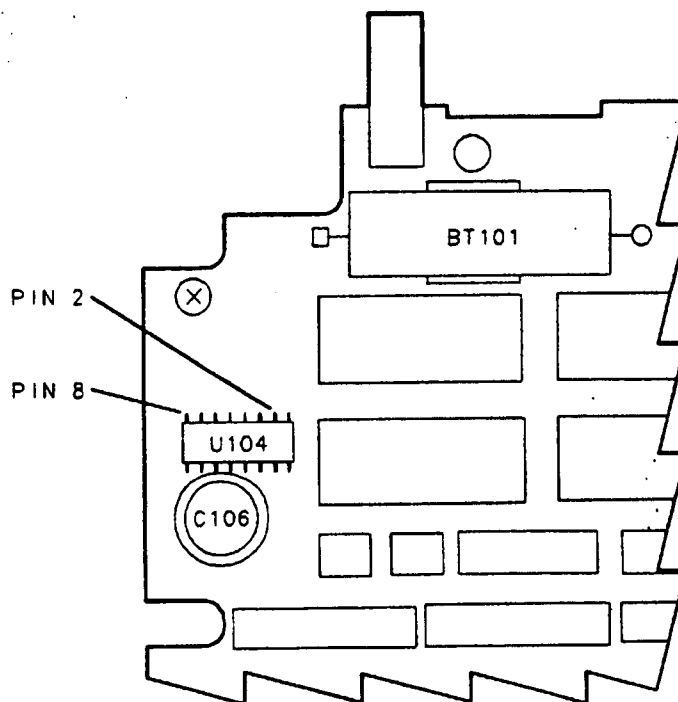

Figure 9-1. Location of U104 on the A16 Assembly

5. Connect a small jumper wire from pin 2 to pin 8 on U104 for approximately 10 seconds.
6. Reconnect the line cord and turn the instrument on.

Instrument Response after Memory Reset

After a memory reset, the spectrum analyzer may display one of the following symptoms:

- A random display periodically flashes on-screen.
- An empty rectangle appears, closely followed by the message SYMTAB EMPTY or INVALID SCR MOVE. Approximately 8 seconds later, the instrument performs an instrument preset and the error message FAIL: 0330 0000000000 is displayed.

If the random display appears, the spectrum analyzer did not automatically load the default-correction data and cannot perform an instrument preset. The CPU is cycling slowly but is not able to recover. Although the softkeys are not visible, load the default-calibration data by performing the following steps:

Note Allow approximately 2 seconds between each key press so that the CPU has time to respond.



-
1. Press **FREQUENCY**.
 2. Enter the -37 Hz passcode.
 3. Press **CAL**.
 4. Press the lowest softkey—**MORE 1 OF 3**.
 5. Press the lowest softkey again—**MORE 2 OF 3**.
 6. Press the third softkey from the top—**DEFAULT CAL DATA**.

After the default calibration-data is accepted, the spectrum analyzer should recover by performing an instrument preset.

- If the spectrum analyzer does not recover, repeat the six steps above.
- If a normal display appears, continue at “Spectrum Analyzer Recovery after a A16 Memory Loss.”
- If the error message FAIL: 0330 0000000000 is displayed, it is not a problem. Continue at the next section.

Spectrum Analyzer Recovery after a A16 Memory Loss

The procedures in this section restore the correction constants recorded on the Correction Constant Backup-Data Record to spectrum analyzer memory, initialize the analyzer settings that are lost after a memory failure, and recalibrate the spectrum analyzer.

Note If the current correction constants are not valid, new correction constants must be generated and stored in memory.



- Perform the steps in “Resetting the Spectrum Analyzer Power-On Units.”
 - Perform the “10 MHz Reference (Standard),” “Frequency Response,” and “Cal Attenuator Error Correction” adjustment procedures in Chapter 2 to generate new correction constants.
 - Return to this procedure and perform the steps in “Instrument Recalibration after Reloading the Correction Constants.”
-

Resetting the Spectrum Analyzer Power-On Units

1. Turn the spectrum analyzer on.

Note



After a memory loss, the spectrum analyzer may display one of the following symptoms:

- A random display periodically flashes on-screen.
- An empty rectangle appears, closely followed by the message SYMTAB EMPTY or INVALID SCR MOVE. Approximately 8 seconds later, the instrument performs an instrument preset and the error message FAIL: 0330 0000000000 is displayed.

Perform the steps in "Instrument Response after Memory Reset" in the previous section and then continue with this procedure.

2. Set the spectrum analyzer power-on units by pressing the following spectrum analyzer keys:

```
PRESET
FREQUENCY -2001 Hz
AMPLITUDE MORE 1 of 3 INPUT 2, 50 75 (50)
AMPLITUDE SCALE LOG LIN (LOG)
MORE 1 of 3 AMPTD UNITS dBm
AMPLITUDE SCALE LOG LIN (LIN)
MORE 1 of 3 AMPTD UNITS Volts
AMPLITUDE SCALE LOG LIN (LOG)
CAL MORE 1 of 3 MORE 2 of 3
SERVICE CAL
STOR POWR ON UNITS
```

Reloading the Timebase and Flatness Correction Constants

Ensure that all recorded correction constants are valid before they are reentered in the instrument memory. Repair, replacement, or adjustment of particular assemblies requires the generation of new correction constants. Refer to Table 6-2, "Adjustments and Tests for Replaced or Repaired Assemblies," for the assemblies that affect the correction constants.

1. Press the following keys to eliminate erroneous data that may be stored in RAM:

```
PRESET
FREQUENCY -37 Hz
CAL MORE 1 of 3 MORE 2 of 3
DEFAULT CAL DATA
```

2. Press the following keys to enter the service calibration menu:

PRESET

FREQUENCY -2001 Hz

CAL MORE 1 of 3 MORE 2 of 3

SERVICE CAL

Note For Option 004 instruments, bypass the next four steps.



3. Press **CAL TIMEBASE**.

4. Enter the value from Table 9-1.

5. Press the following keys to store the timebase data in memory:

CAL MORE 1 of 3

CAL FETCH

MORE 2 of 3 MORE 3 of 3

CAL STORE

6. Press the following keys to reenter the passcode and return to the service calibration menu:

FREQUENCY -2001 Hz

CAL MORE 1 of 3 MORE 2 of 3

SERVICE CAL

7. On the spectrum analyzer press the following keys:

FLATNESS DATA

IDNUM 5 (ENTER)

8. Press **INIT FLT** to initialize the area of memory where the flatness data is stored, and set the start frequency, stop frequency and step size for the entry of the flatness correction constants.

9. Press the following keys before entering the correction data:

FREQUENCY -2001 Hz

CAL MORE 1 of 3 MORE 2 of 3

SERVICE CAL

FLATNESS DATA

EDIT FLATNESS

10. Enter the correction constant for 12 MHz from Table 9-2 and terminate the entry with the **(+dBm)** or **(-dBm)** key, as appropriate.
11. Enter each correction constant from Table 9-2. Each entry is displayed briefly before the data-entry routine steps to the next correction data point.
12. Use **(↑)** and **(↓)** to edit previously entered correction data.
13. When all flatness correction constants are entered, press **STORE FLATNESS**. The spectrum analyzer will automatically preset.

Reloading the A12 Step-Gain-Correction Constants

1. Press the following keys before reloading the step-attenuator correction constants:

PRESET

FREQUENCY -2001 **(Hz)**

CAL MORE 1 of 3 MORE 2 of 3

SERVICE CAL

SET ATTN ERROR

REF LVL OFFSET is displayed in the active-function block above the prompt ENTER CAL ATTN ERROR 1.

2. At the prompt, Enter the five step-attenuator correction constants (resolution 0.01 dB) from Table 9-4.

Terminate each entry with either **(+dBm)** or **(-dBm)**, as appropriate. Each entry is displayed to the left of the graticule as an amplitude offset, but only with 0.1 dB resolution. An instrument preset occurs after the 16 dB step-attenuator error is entered.

Instrument Recalibration after Reloading the Correction Constants

1. Connect the CAL cable from CAL OUT to INPUT 50Ω.
2. Perform the self-calibration routines by pressing the following keys:

PRESET

FREQUENCY -37 **(Hz)**

CAL FREQ & AMPTD

When CAL: DONE is displayed in the active-function block, the instrument is calibrated. The calibration procedure takes approximately 8 minutes.

3. Perform the "CAL YTF" and "CAL MXR" adjustment procedures in Chapter 2.
4. Adjust the vertical and horizontal position of the display using **CRT VERT POSITION** and **CRT HORZ POSITION**.
Refer to the "Display Position" section of the "Display" adjustment procedure in Chapter 2.
5. Press **CAL** and **CAL STORE** to store the correction values in nonvolatile memory.

Note

Refer to the *HP 8594A/8595A Spectrum Analyzer Installation and Verification Manual* for a description of the default settings provided by **DEFAULT CONFIG**.

6. Press the following keys to clear user memory and return the instrument to the default configuration:

CONFIG

MORE 1 of 2

DISPOSE USER MEM

DEFAULT CONFIG

7. If a new A16 assembly (with a new battery attached) is installed, enter the replacement date on the battery label located on the rear-frame of the spectrum analyzer.
8. Adjust the time and date. Refer to the "Time and Date" adjustment procedure in Chapter 2 of this manual.

A7 Analog Interface Assembly

Note



The function-block letter designators shown in the block diagram correspond to the designators on the assembly schematic in the CLIP.

The A7 Analog Interface assembly interprets commands from the A16 Processor/Video assembly, and produces control signals that are compatible with the individual control requirements of each assembly.

The following assemblies in the RF section receive control signals from the A7 assembly:

- A3A1 Comb Generator
- A3A2 Switched YTF (YIG-Tuned Filter)
- A3A4 Second Converter
- A3A5 Input Attenuator
- A3A6 Dual Band Mixer
- A9 Third Converter

Refer to Foldout 7-1, RF Section Block Diagram, for more information about the RF assemblies.

The A3A7 YTO in the LO section receives control signals from the A7 assembly. Refer to Foldout 7-2, LO Section Block Diagram, for more information about the YTO.

The following assemblies in the IF section receive control signals from the A7 assembly:

- A11 Bandwidth Filter
- A12 Amplitude Control
- A13 Bandwidth Filter
- A14 Log Amplifier

Refer to "IF Section Information" and "A15 Motherboard Assembly" in Chapter 8 when tracing control lines in the IF section.

Refer to Foldout 9-1, A7 Analog Interface Assembly Block Diagram, at the end of this section for details about the operation of the A7 assembly.

The A7 assembly processes the digital commands sent over the IOB by the A16 Processor/Video Assembly and sends various control signals to the assemblies listed above. There are three types of control signals:

- DAC outputs are used to adjust amplifier gains, IF filter bandwidths, and mixer bias current.
- Current sources are used to tune the YTO and YTF.
- On/Off control voltages are used to switch the input attenuator steps, the RF switch, various PIN diode switches, and amplifier stages.

The A7 assembly also routes several key voltages to the main ADC on the A16 assembly. The CPU uses the test point voltages to monitor the performance of individual assemblies. These

voltage values are used during the self-calibration routines and while related **SERVICE DIAG** softkey functions are in use. Refer to Chapter 10 for more information.

A7 ANALOG INTERFACE ASSEMBLY

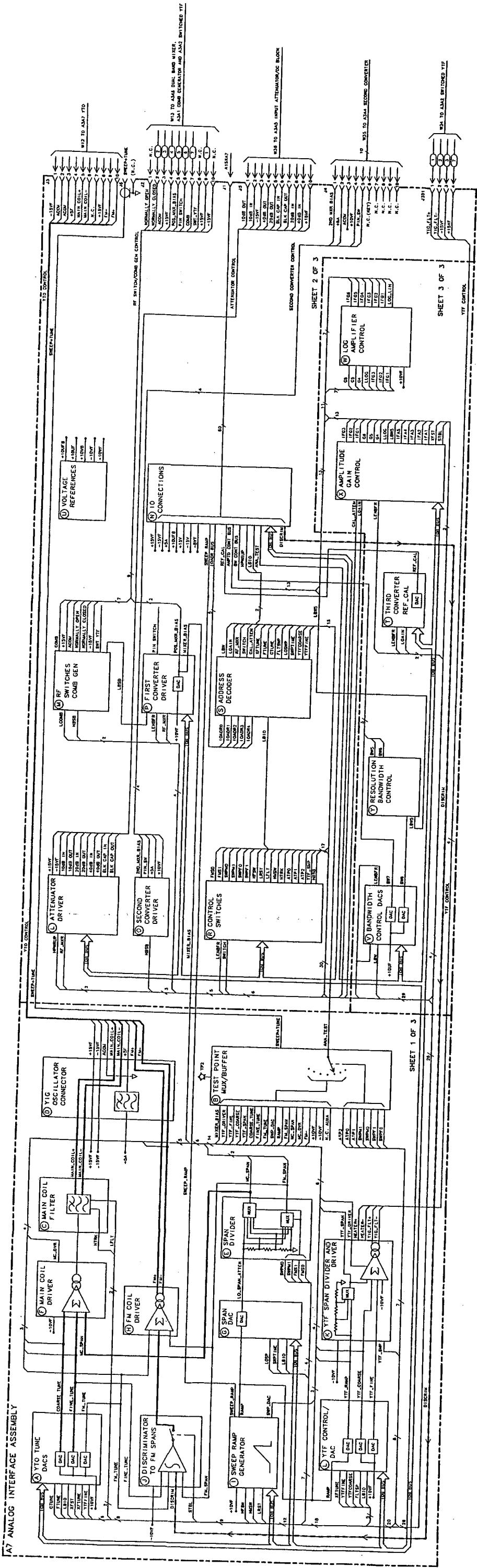

FOLDDOUT 9-1. HP 8595A A7 ANALOG INTERFACE ASSEMBLY, BLOCK DIAGRAM
Control/Display Section Troubleshooting

Softkey Descriptions

Introduction

Refer to this chapter for an explanation of the HP 8594A Spectrum Analyzer passcodes, the two types of instrument correction data, and the service-related softkeys that are available after pressing **CAL**.

The calibration, service, and diagnostic softkey functions are listed alphabetically. A list of service-related softkeys follows each softkey description, when appropriate. Refer to the description of each related softkey to understand how the softkey functions interrelate.

Calibration, Service, and Diagnostic Softkey Functions

The front-panel **CAL** key provides the softkey menus for the self-calibration routines, the confidence test, the service-calibration and service-diagnostic routines. Refer to Figure 10-1 for the organization of the softkeys related to **CAL**.

Caution



Correction-constant data can be lost if the **SERVICE-CAL** softkeys are used improperly. Refer to the appropriate softkey description for instructions on softkey usage.

CAL Softkey Organization

Figure 10-1 provides the organization of all softkeys available after pressing **CAL**. Each block of softkeys represents the softkeys that are displayed at one time. The diagram flow indicates the actual key sequence used for each softkey. The footnotes identify softkeys that appear only when a passcode has been entered or a specific instrument option is installed in the analyzer.

CAL

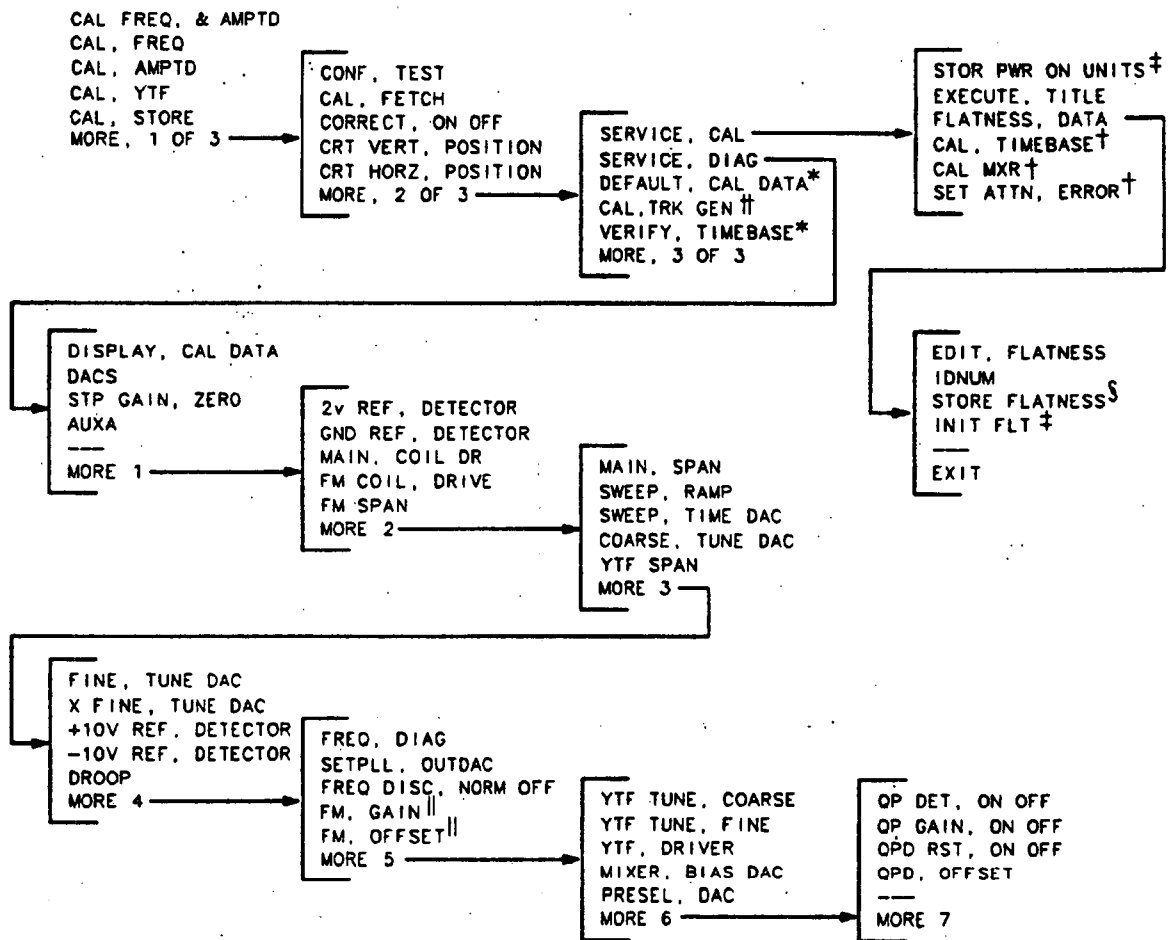

* Function is not active unless either -37 Hz or -2001 Hz Passcode is entered.
 † Function is not active unless -2001 Hz Passcode is entered.
 ‡ Present only if -2001 Hz Passcode is entered.
 § Present only if -2001 Hz Passcode is entered and "EDIT FLATNESS" softkey is pressed.
 †† Present for Option 102 only.
 †† Present for Option 010 only.

Figure 10-1. Calibration, Service, and Diagnostic Softkey Tree

Passcodes

Passcodes activate specific softkey functions and protect the correction data from accidental erasure or modification. The two passcodes, -37 Hz and -2001 Hz, are explained below.

- Use the -37 Hz passcode to perform the following functions:
 - Replace the current calibration-factors with the default calibration data provided by **DEFAULT CAL DATA**.
 - Check the accuracy of the 10 MHz frequency reference using **VERIFY TIMEBASE**. Refer to the 10 MHz Reference Accuracy (Standard Timebase) Verification Test in the *HP 8594A/8595A Installation and Verification Manual*.
 - Bypass the CAL OUT set-up check within individual self-calibration routines.
- Use the -2001 Hz service passcode to perform the following functions:
 - Set the model number of the spectrum analyzer using **IDNUM**.
 - Set the start frequency, stop frequency, and step size of the flatness correction points using **INIT FLT**.
 - Edit the flatness-correction constants using **EDIT FLATNESS**.
 - Edit the A12 Amplitude Control step-attenuator correction constants using **SET ATTN ERROR**.
 - Set the correction factor for the 10 MHz frequency reference (standard timebase).
 - Modify the displayed power units that appear when the instrument is first turned on using **STOR PWR ON UNITS**.
 - Bypass the CAL OUT signal check within individual self-calibration routines.

Entering A Passcode

The passcode must be entered before pressing **CAL**. Press the following keys to enter a passcode.

FREQUENCY

-37 **Hz** or -2001 **Hz**

CAL

When SRVC appears in the lower-left corner of the display, the passcode has been accepted.

Understanding Instrument Correction Data

The firmware uses correction data to improve instrument performance by minimizing the effect of variations in hardware. There are two categories of correction data:

- Self-calibration correction factors.
- Service-calibration correction constants.

All correction data can be displayed and modified with the softkey functions provided by **CAL**.

Self-Calibration Correction Factors

Self-calibration correction factors enhance instrument accuracy by adjusting DACs on the A7 Analog Interface assembly and by adding offsets to trace information. The correction factor data is stored in nonvolatile memory on the A16 Processor/Video assembly after pressing **CAL STORE**.

The correction-factor data is produced by the **CAL AMPTD** and **CAL FREQ** self-calibration routines. The horizontal and vertical display positions, adjusted by **CRT VERT POSITION** and **CRT HORZ POSITION**, are also retained.

Refer to the softkey descriptions in this section for further information.

Service-Calibration Correction Constants

The service-calibration correction constants enhance instrument performance by compensating for frequency-response variation and A12 Amplitude Control step-attenuation errors. The correction constants are unique for each instrument.

The correction constants for frequency response can be viewed, or modified, using **FLATNESS DATA**. Refer to the Frequency Response adjustment procedure in Chapter 2 for instructions on generating new correction constants.

The correction constants for step-attenuation errors on the A12 Amplitude Control assembly can be modified using **SET ATTN ERROR**. Refer to the Cal Attenuator adjustment procedure in Chapter 2 for instructions on generating new correction constants.

The frequency of the 10 MHz standard timebase, a room temperature crystal oscillator (RTXO), is controlled by a DAC located on the A25 Counter Lock assembly. Refer to the 10 MHz Reference (Standard) procedure in chapter 2 to adjust the timebase DAC using **CAL TIMEBASE**.

The initial service-calibration correction constants are stored by the factory in nonvolatile memory on the A16 assembly. After shipment, new correction constants must be manually generated whenever an adjustment or repair affects frequency response or A12 Amplitude Control step attenuation.

Refer to "After an Instrument Repair" in Chapter 6 for the specific assemblies that affect frequency response. Whenever the A16 Processor/Video assembly is replaced, new correction constants must also be generated, unless valid correction constants were saved prior to the instrument failure.

Note

The manual generation of the new service-calibration correction constants is a lengthy procedure. Avoid having to generate new correction constants manually by periodically recording the current correction constants. Refer to "Backing Up Analyzer Correction Constants" in Chapter 9.

Refer to the softkey descriptions in this section for specific information about the use and modification of the correction-constant data.

+10 V REF DETECTOR +10 V Reference Detector

DESCRIPTION Displays the output of the +10 V reference from the A7 Analog Interface assembly as a horizontal line along the top graticule. The analyzer must be in a single-band sweep for the display to be valid.

Refer to "A7 Analog Interface Assembly" in Chapter 9 for additional troubleshooting information.

**RELATED
SOFTKEYS**

-10 V REF DETECTOR

-10 V REF DETECTOR -10 V Reference Detector

DESCRIPTION Displays the output of the -10 V reference from the A7 Analog Interface assembly as horizontal line at the bottom graticule. The analyzer must be in a single-band sweep for the display to be valid.

Refer to "A7 Analog Interface Assembly" in Chapter 9 for additional troubleshooting information.

**RELATED
SOFTKEYS**

+10 V REF DETECTOR

2V REF DETECTOR 2 V Reference Detector

DESCRIPTION Displays the output of the 2 V reference produced on the A16 Processor/Video assembly as a horizontal line at the top graticule. If the line is at the top graticule, the main ADC is adjusted correctly.

This routine uses the 2 V reference at the input MUX on the A16 assembly. Refer to Foldout 6-2, IF/Control Overall Block Diagram, for the location of the input MUX.

Note



During **PRESET**, The analog-ground and 2 V signal are used to calibrate the main ADC. The analog ground and 2 V reference at the input MUX are used during calibration. If either signal is out of range, the **ADC-GND FAIL** or **ADC-2V FAIL** error message is displayed.

**RELATED
SOFTKEYS**

CAL AMPD

AUXA Auxiliary A

DESCRIPTION Displays the voltage present at the AUX A connector, A7J7, on the A7 Analog Interface assembly. At present the AUX A function is not used and no connection is made to A7J7. The AUX A input to the A16 Processor/Video assembly floats to a high positive voltage. When **AUX A** is selected, a horizontal line above the top graticule line is displayed.

CAL Calibration Key

DESCRIPTION **CAL** provides access to the softkeys for the self-calibration, service-diagnostics, and service-calibration functions. A passcode is required for access to specific softkeys.

RELATED SOFTKEYS Refer to Figure 10-1 at the beginning of this chapter for the softkeys that are available after pressing **CAL**.

CAL AMPTD Calibrate Amplitude

DESCRIPTION

Note



If both **CAL FREQ** and **CAL AMPTD** self-calibration routines are required, perform the **CAL FREQ** routine first.

The **CAL AMPTD** softkey initiates an amplitude self-calibration routine. Connect **CAL OUT** to the analyzer input before pressing **CAL AMPTD**.

During the **CAL AMPTD** self-calibration routine, messages are sequentially displayed, indicating a specific calibration activity. Each calibration performed by **CAL AMPTD** is described below.

- While **CAL AMPTD** is displayed, the following calibrations are performed:
 - The amplitude error of each resolution bandwidth is corrected using the 3 kHz resolution bandwidth as the amplitude reference. Each amplitude error is then stored as a calibration factor.
 - The center frequency error of each bandwidth is corrected.
 - The top-screen reference level is calibrated using the amplitude of the **CAL OUT** signal as a reference.
 1. The amplitude of the detected 21.4 MHz IF signal is measured on the A16 Processor/Video assembly.

2. The Reference-Level-Calibration DAC on the A7 Analog Interface assembly adjusts the gain of the IF Calibration Amplifier on the A9 Third Converter assembly to correct the amplitude measured on the A16 assembly.
 3. After the A7 DAC adjusts the A9 output, fine amplitude corrections are made with a digital offset of the video signal on the A16 assembly.
 4. The A7 DAC value and video offset are stored as correction factors on the A16 assembly.
- While CAL: 3dB BW is displayed, the following calibrations are performed:
 - The 3 dB and 6 dB EMI resolution bandwidths are measured.
 - DACs on the A7 Analog Interface assembly adjust the bandwidth of the LC and crystal filters on the A11 and A13 Bandwidth Filter assemblies.
 - The DAC bandwidth correction factors are stored on the A16 Processor/Video assembly.
 - While CAL: ATTEN is displayed, the following calibrations are performed:
 - The amplitude error of the 10 dB step gains on the A12 Amplitude Control assembly and the 10 dB linear gains on the A14 Log Amplifier/Detector assembly are corrected.

The 10 dB step gain on the A12 assembly is the amplitude reference.

Step-gain and linear-gain errors are corrected with digital offsets of the video signal on the A16 assembly.

The video offsets are stored as correction factors.

- Amplitude errors for the A3A5 Input Attenuator are corrected.

The 10 dB step attenuator is the amplitude reference.

Input attenuator errors are corrected with digital offsets of the video signal on the A16 assembly.

The attenuator offsets are stored as correction factors.

- While CAL: LOG AMP is displayed, the following calibrations are performed:
 - The log fidelity is measured in 1 dB steps.
 - Errors are corrected with digital offsets of the video signal on the A16 assembly.
 - The video offsets are stored as correction factors.

If a failure occurs during this calibration routine, an error message is displayed. Refer to Chapter 11 for the description of displayed error messages.

Note

Be sure to press **CAL STORE** after running the **CAL AMPTD** routine.

**RELATED
SOFTKEYS****DISPLAY CAL DATA****CAL FREQ****CAL FREQ & AMPTD****CAL FETCH****CAL STORE****CORRECT ON OFF**

CAL FETCH Calibration Fetch**DESCRIPTION**

CAL FETCH retrieves the self-calibration correction factors from the area of memory that retains data when the analyzer is turned off and places it in working (volatile) RAM memory.

Caution

Pressing **CAL FETCH** clears the correction-data-error flag and can permit erroneous data to be stored. Use **CAL FETCH** only for troubleshooting.

**RELATED
SOFTKEYS****CAL AMPTD****CAL FREQ****CAL FREQ & AMPTD****CAL STORE**

CAL FREQ Calibrate Frequency

DESCRIPTION **CAL FREQ** initiates the frequency self-calibration routine. Connect CAL OUT to the analyzer input before initiating **CAL FREQ**.

Note  It is normal for the FREQ UNCAL error message to appear briefly during **CAL FREQ**.

During the **CAL FREQ** self-calibration routine, messages are sequentially displayed, indicating a specific calibration activity. Each function performed by **CAL FREQ** is described below.

- Before the calibration routine starts, an instrument setup check is performed.

The CAL OUT signal must be within 300 MHz \pm 50 MHz and greater than or equal to -45 dBm to pass the setup check. If the CAL OUT signal is not present, the routine stops.

If the **DEFAULT CAL DATA** correction factors are in use, a frequency offset may occur that prevents the CAL OUT signal from being found. If desired, the instrument setup check can be bypassed. Enter the -37 Hz passcode before pressing **CAL** and **CAL FREQ**.

Refer to the CAL SIGNAL NOT FOUND error message description in Chapter 11 for more information.

- While CAL: SWEEP is displayed:
 - The sweep ramp is calibrated.
 - The values are stored as correction factors.
- While CAL: FREQ is displayed:
 - Harmonics of the CAL OUT signal are used to adjust the start and stop end-points for the A3A7 YTO.
 - The end-point values are stored as correction factors.
- While CAL: SPAN is displayed:
 - The main-coil sweep sensitivity and span attenuator are adjusted for LO spans greater than 10 MHz.
 - The adjustment routine checks for three displayed signals: 0 Hz, 300 MHz, and 600 MHz. The test passes if all three signals are found within a 750 MHz span.
- FM DAC Error Check:
 - The analyzer changes the center frequency setting to move the displayed signal four divisions.
 - If the signal moves within \pm 1.25 divisions of the expected display position, the FM coil drive is within tolerance.

- Instruments equipped with Option 102, AM/FM Speaker and TV Sync Trigger, display the message CAL: FM GAIN + OFFSET. While CAL: FM GAIN + OFFSET is displayed:
 - The FM offset DAC is adjusted to position the signal at center-screen. This calibrates the center screen-position so that it represents an unmodulated signal.
 - The top to bottom screen deviation of a demodulated FM signal, referenced to center screen, is calibrated for a specific frequency deviation.
 - A demodulated signal with a 100 kHz frequency deviation is simulated using the CAL OUT signal and a center frequency step of 100 kHz.
 - The center frequency is stepped up and the FM gain is adjusted to position the signal at top screen.
 - The center frequency is stepped down and the FM gain is adjusted to position the signal at bottom-screen.

If a failure occurs during this calibration routine, an error message is displayed. Refer to Chapter 11, Analyzer Messages, for the description of displayed error messages.

Note

Be sure to press **CAL STORE** after running the **CAL FREQ** routine.



**RELATED
SOFTKEYS**

CAL AMPTD

CAL FREQ & AMPTD

CAL FETCH

CAL STORE

DISPLAY CAL DATA

FM GAIN

FM OFFSET

CAL FREQ & AMPTD Calibrate Frequency and Amplitude

DESCRIPTION **CAL FREQ & AMPTD** initiates both the frequency and amplitude self-calibration routines. Connect CAL OUT to the analyzer input before initiating **CAL FREQ & AMPTD**.

Note Be sure to press **CAL STORE** after running the **CAL FREQ & AMPTD** routine.



**RELATED
SOFTKEYS**

CAL AMPTD

CAL FREQ

CAL FETCH

CAL STORE

CAL MXR Calibrate Mixer

DESCRIPTION

Note Use **CAL MXR** in the order of adjustment and test routines provided in "After an Instrument Repair" in Chapter 6.



The high-band mixer in the A3A6 Dual-Band Mixer receives a mixer-bias current from a DAC on the A7 Analog Interface assembly. The mixer-bias current must be adjusted for each frequency band to minimize conversion loss in the A3A6 Dual-Band Mixer.

Note Use the YTF CAL cable when performing the **CAL MXR** routine. Refer to Table 1-4 for the cable part number.



The **CAL MXR** routine adjusts the bias-current DAC setting for the optimum displayed-signal amplitude, using the 100 MHz COMB OUT signal. The routine adjusts the bias current at several frequencies in each band; an optimum bias setting for that band is then determined. During the routine, **TRACE A** displays the frequency spectrum, while **TRACE B** displays the signal amplitude versus mixer-bias DAC setting.

The -2001 passcode must be entered to activate the **CAL MXR** calibration routine. Enter the passcode before pressing the **(CAL)** key.

Note

The **CAL YTF** routine must be performed before running the **CAL MXR** routine. New frequency response correction constants must also be generated whenever the **CAL MXR** routine is used. Refer to the **CAL MXR** adjustment routine in Chapter 2 for instructions on the use of the **CAL YTF** and **CAL MXR** routines.

Once the **CAL MXR** routine is finished, the optimum bias-current value for each frequency band is displayed. The displayed values are the mixer bias DAC setting multiplied by 16. The DAC values are automatically stored as correction constants in nonvolatile memory on the A16 Processor/Video assembly.

**RELATED
SOFTKEYS****CAL YTF****EDIT FLATNESS**

CAL STORE Calibration Store**DESCRIPTION**

CAL STORE copies the correction factors from working RAM to the area of memory on the A16 Processor/Video assembly that retains data after the analyzer is turned off.

Caution

If the correction factors are not stored, they will be lost when the analyzer is turned off.

**RELATED
SOFTKEYS****CAL AMPTD****CAL FREQ****CAL FREQ & AMPTD****CAL FETCH****CAL YTF****CAL TIMEBASE****CRT VERT POSITION****CRT HORZ POSITION**

CAL TIMEBASE Calibrate Timebase

DESCRIPTION

Note

Instruments equipped with Option 004, Precision Frequency Reference, do not use this softkey function.



Use this softkey to change the setting of the 10 MHz reference (standard timebase) DAC on A25 Counter Lock assembly.

The -2001 Hz passcode must be entered to activate this function.

The DAC controls the frequency of the internal 10 MHz oscillator over a frequency range of approximately 65 ppm. At a 10 MHz nominal frequency, one DAC count provides a resolution of less than 0.5 ppm. The DAC has an adjustment range of 0 to 255.

Refer to the 10 MHz Frequency Reference Adjustment procedure in Chapter 2 for further information on the use of **CAL TIMEBASE**.

Note

Be sure to press **CAL STORE** to store the timebase DAC setting.



RELATED SOFTKEYS

CAL STORE

DEFAULT CAL DATA

VERIFY TIMEBASE

DISPLAY CAL DATA

CAL YTF Calibrate YTF

DESCRIPTION

Note

The user should perform the **CAL YTF** routine if there has been a large change in ambient temperature.



In band 1, amplitude accuracy, particularly frequency response, is a function of how well the A3A2 YTF bandpass filter tracks the tuned frequency of the analyzer. YTF tuning is controlled by DACs located on the A7 Analog Interface assembly. **CAL YTF** minimizes amplitude uncertainty due to YTF tracking by determining the optimum YTF DAC settings.

Note

Use the YTF CAL cable when performing the **CAL YTF** routine. Refer to Table 1-4 for the cable part number.

The **CAL YTF** routine, using the 100 MHz COMB GEN OUT signal, tunes the analyzer to two frequencies. The routine minimizes tracking error by adjusting the YTF coarse- and fine-tune DAC settings for an optimum displayed-signal amplitude. **TRACE A** displays the typical frequency spectrum and **TRACE B** displays the amplitude versus YTF DAC setting.

The routine then sets the analyzer to sweep over the frequency range. The YTF Span DAC is adjusted for the maximum swept-amplitude response in each band. During this part of the routine, **TRACE A** displays the frequency spectrum, and **TRACE B** displays the amplitude versus YTF span DAC setting.

Note

Be sure to press **CAL STORE** after running the **CAL YTF** routine.

**RELATED
SOFTKEYS****CAL STORE****CAL MXR**

COARSE TUNE DAC Coarse Tune DAC**DESCRIPTION**

Displays the analog output of the YTO coarse-tune DAC located on the A7 Analog Interface assembly. The mnemonic for the control voltage is C_TUNE. The instrument must be in a single-band sweep for the display to be valid.

When **COARSE TUNE DAC** is selected, a horizontal line is displayed in the lower four divisions of the screen. The line represents the 0 V to -10 V DAC output voltage. When the YTO DAC voltage becomes more negative, the YTO frequency is increased, and the displayed line moves lower on screen.

Refer to Chapter 7 for additional LO troubleshooting information.

**RELATED
SOFTKEYS****FINE TUNE DAC**

CONF TEST Confidence Test

DESCRIPTION

This test automates an informal, visual test that quickly checks the basic operation of six IF and video functions. Each test checks for a simple change in signal position when the analyzer settings for the function under test are changed. Instrument specifications are not used as test limits.

If a test failure occurs, the error message **CONF TEST FAIL** is displayed along with error messages for the failed test. Each check and its corresponding error message are described below.

1. Positive-Peak Detector Check and error message POS-PK FAIL.

The test checks switching for the positive-peak detector. The noise-floor level should increase when switching from the sample detector to the positive-peak detector.

The test detects the noise-floor increase by statistically comparing the level of the noise floor for the positive-peak detector to the level for the sample detector.

If the error message **POS-PK FAIL** is displayed, the mean of the data from the positive-peak detector is less than the mean from the sample detector data.

2. Sample-Detector Check and error message SAMPLE FAIL.

The test checks switching for the sample detector. The peak-to-peak amplitude of the noise floor for the sample detector should be wider than the noise floor for the positive-peak detector.

The test detects the wider noise floor by statistically comparing the peak-to-peak amplitude of the noise floor for the sample detector to the noise floor for the positive-peak detector.

If the error message **SAMPLE FAIL** is displayed, the standard deviation of the data from the sample detector is less than the standard deviation of the data from the positive-peak detector.

3. Video-Bandwidth Check and error message VID-BW FAIL.

The test checks video-bandwidth switching by stepping the analyzer from the widest video bandwidth setting to the narrowest.

The test detects switching activity by comparing the peak-to-peak amplitude of the noise floor for each video bandwidth.

If the error message **VID-BW FAIL** is displayed, the peak-to-peak amplitude did not decrease when a narrower video bandwidth was switched on.

4. Resolution-Bandwidth Noise Check and error message RES-BW NOISE FAIL.

The test makes a relative comparison of noise-floor amplitude for each resolution bandwidth.

The test compares the noise-floor amplitude of each resolution bandwidth to that of the next, narrower resolution bandwidth.

If the error message RES-BW NOISE FAIL is displayed, a decrease in the noise floor amplitude did not occur when the test switched to the narrower bandwidth. The test displays the narrower bandwidth as the test failure and displays all bandwidths that fail.

5. A12 Step-Gain Check and error message STEP GAIN/ATTEN FAIL.

The test checks the switching of the step gains on the A12 Amplitude Control assembly. The test does not check step-gain accuracy.

The test steps the reference level from -60 dBm to +30 dBm, in 10 dB increments, with the input attenuator set to 60 dB.

The test detects step-gain switching activity by comparing the noise-floor level for each 10 dB step gain.

If the error message STEP GAIN/ATTEN FAIL is displayed, the displayed noise level did not decrease when the reference level was changed.

6. 3 dB Resolution-Bandwidth Check and error message RES-BW SHAPE FAIL.

The test checks the 3 dB resolution bandwidth of the 10 kHz, 30 kHz, 100 kHz, 300 kHz, 1 MHz, and 3 MHz bandwidth filters.

If the error message RES-BW SHAPE FAIL is displayed, the bandwidths that are displayed with the error message are not within $\pm 20\%$. Resolution bandwidth accuracy is a characteristic, not a specification.

Check the failed bandwidths manually using the **3 dB POINTS** softkey.

CORRECT ON OFF Correction On/Off

DESCRIPTION

The analyzer corrects for variations in hardware performance in two ways:

- Digital offsets of the video signal on the A16 Processor/Video assembly.
- Adjustment of the DAC control voltages provided by the A7 Analog Interface assembly.

The **CORRECT ON OFF** function affects only the digital offsets of the video signal.

The uncorrected performance of individual assemblies can be checked by disabling the correction data. The following corrections are disabled when **CORRECT OFF** is selected:

- Step-gain-error correction factors. New correction factors are produced by the **CAL AMPTD** self-calibration routine.

- Bandwidth-amplitude correction factors. New correction factors are produced by the **CAL AMPTD** self-calibration routine.
- Log-scale-fidelity correction factors. New correction factors are produced by the **CAL AMPTD** self-calibration routine.
- Input-attenuator correction factors. New correction factors are produced by the **CAL AMPTD** self-calibration routine.
- Bandwidth-centering correction factors. New correction factors are produced by the **CAL AMPTD** self-calibration routine.
- Flatness-correction constants. The original constants are placed in the analyzer memory at the factory. New constants must be generated manually using the Frequency Response adjustment procedure in Chapter 2.
- A12 Amplitude Control step-attenuator-correction constants. The original constants are placed in the analyzer memory at the factory. New constants must be generated manually using the Cal Attenuator Error Correction procedure in Chapter 2.

The **CORRECT ON OFF** function does not affect the following DAC adjustments:

- Resolution bandwidth corrections.
- Reference level amplitude correction.
- YTO frequency and span corrections.
- 10 MHz reference (standard timebase) DAC correction.

Refer to the **CAL AMPTD** description in this chapter and "Locating RF/IF/LO Problems" in Chapter 6 when the displayed signal exhibits symptoms of either low or high gain.

**RELATED
SOFTKEYS**

CAL AMPTD

CAL FREQ

CAL STORE

DEFAULT CAL DATA

CRT HORZ POSITION CRT Horizontal Position

- DESCRIPTION** The softkey provides an adjustment for the horizontal display position.
- Press **CRT HORZ POSITION** and use the A1A2 knob on the front panel to adjust the display.
- If the A1A2 knob is turned too far clockwise, the display will become distorted. This is a normal response; simply readjust the knob counterclockwise.
- If desired, press **CAL STORE** to retain the new display position.

**RELATED
SOFTKEYS**

CRT VERT POSITION

CAL STORE

DEFAULT CAL DATA

CRT VERT POSITION CRT Vertical Position

- DESCRIPTION** The softkey provides the following adjustment for the vertical display position:
- Press **CRT VERT POSITION** and use the A1A2 knob on the front panel to adjust the display.
 - If desired, press **CAL STORE** to retain the new display position.

**RELATED
SOFTKEYS**

CRT HORZ POSITION

CAL STORE

DEFAULT CAL DATA

DACS DACs

- DESCRIPTION** Use **DACS** to change the DAC numbers of the span, YTO coarse-tune, YTO fine-tune, and YTO FM tune DACs located on the A7 Analog Interface assembly. The following terminator keys are used to select the desired DAC.

YTO Adjustment DAC Selection	Terminator Key
Span DAC	GHz
YTO coarse-tune DAC	MHz
YTO fine-tune DAC	kHz
YTO FM tune DAC	Hz

Press the following keys to select a YTO adjustment DAC:

SGL SWP

CAL

MORE 1 OF 3

MORE 2 OF 3

SERVICE DIAG

DACS

Press the terminator key for the desired DAC.

Each DAC may be set to any integer between 0 and 4095 using the A1A2 knob on the front panel. Use the **↑** and **↓** keys to make large changes in the DAC settings:

- The **↑** key increments the DAC setting in an even binary progression of 0, 2, 4, 8, 16, ... , 4096.
- The **↓** key decrements the DAC setting in an odd binary progression of 4095, 2047, 1023, 511, ... , 1.

Refer to Chapter 7 for additional LO troubleshooting information.

RELATED
SOFTKEYS

COARSE TUNE DAC

FINE TUNE DAC

X FINE TUNE DAC

FM SPAN

MAIN SPAN

DEFAULT CAL DATA Default Calibration Data

DESCRIPTION

The current correction-factor data is replaced in nonvolatile memory by the factory-loaded default calibration data when **DEFAULT CAL DATA** is used. The default data can be used only if a passcode, either -37 Hz or -2001 Hz, has been entered.

There are two types of correction factors that are changed when the default data is used:

- Video offsets. They are used on the A16 Processor/Video assembly.
- DAC settings. They are used on A7 Analog Interface assembly.

After entering the passcode and pressing **DEFAULT CAL DATA**, the default data can be viewed using **DISPLAY CAL DATA**. Figure 10-2 provides the screen display of the default-calibration data.

MISC-FREQ	RL-VENR	ERR	BW-AMP	LC-XTAL	SGAIN	RFATN
300000000	200	X.XX	0.00	0 255	0.00	0.00
250000000	200	X.XX	0.00	0 255	0.00	0.00
519000000	200	X.XX	0.00	0 255	0.00	0.00
207250000	200	X.XX	0.00	0 255	0.00	0.00
0.000200000	200	X.XX	0.00	0 91	0.00	0.00
0.000001010	200	0.00	0.00	0 255	0.00	0.00
10320000000	200	0.00	0.00	0 214	0.00	0.00
1.000000000	200	0.00	0.00	0 158	0.00	0.00
0	200	0.00	0.00	0 91	0.00	
0	200	0.00	0.00	0 1	0.00	TC
0.059500001	200	0.00	0.00	0 255		XXXX
129	200	0.00	0.00	98 255		XXXXX
0	200	0.00	0.00	163 255		XXXX
200	200	0.00	0.00	218 255	X.XXXXXXXX	
500	200	0.00	0.00	255 255	X.XXXXXXXX	
65	XXX	0.00	0.00	0 255	X.XXXXXXXX	

* The values indicated are not default data and are different for each analyzer.

Figure 10-2. Default Calibration Data

The following A16 video offsets are reset to zero when **DEFAULT CAL DATA** is used. Refer to Figure 10-2.

- Amplitude correction factors. Refer to the "ERR" column.

When the analyzer is calibrated using **CAL AMPTD**, the correction factors fine-tune the amplitude calibration of the reference level at top screen.

Note



The top five entries in the "ERR" column are correction constants for the A12 Amplitude Control step-attenuators. They are not reset and are different for each instrument.

- Bandwidth amplitude correction factors. Refer to the "BW-AMP" column.

- A12 amplitude control step-gain correction factors. Refer to the "SGAINS" column.
- Input attenuator correction factors. Refer to the "RFATN" column.

The following DACs are reset to predetermined values when **DEFAULT CAL DATA** is used. Refer to Figure 10-2.

- Amplitude correction factors for the Reference Level Vernier. Refer to the "RL-VENR" column.

When the analyzer is calibrated using **CAL AMPTD**, the correction factors coarse-tune the amplitude calibration of the reference level at top screen.

- Bandwidth correction factors. Refer to the "LC-XTAL" column.
- Correction factors for A3A7 YTO span error. Refer to "FM SWPSENS" and "MAIN SWPSENS" in the "MISC-FREQ" column.

Default correction values for span error can offset the frequency of a displayed signal.

- Frequency correction factors for the A3A7 YTO. Refer to "FM COILSENS" and "MAIN COILSENS" in the "MISC-FREQ" column.

Default YTO correction values can offset the frequency of a displayed signal.

- Frequency correction factor for the 10 MHz Frequency Reference (standard timebase). Refer to the last entry of the "RL-VENR" column. Refer to the **CAL TIMEBASE** description for more information.

Refer to the **DISPLAY CAL DATA** description for more information about the display of correction data.

RELATED
SOFTKEYS

DISPLAY CAL DATA

CAL FREQ

CAL AMPTD

CAL TIMEBASE

CORRECT ON OFF

DISPLAY CAL DATA Display Calibration Data

DESCRIPTION

Displays the current correction-factor data generated by the **CAL FREQ** and **CAL AMPTD** self-calibration routines. Refer to Figure 10-3 for the location of each data column displayed when using **DISPLAY CAL DATA**. Press **PRESET** to exit the data display.

MISC-FREQ	RL-VENR	ERR	BW-AMP	LC-XTAL	SGAIN	RFATH
CALFRQ	200	-1dB	0.00	0 255	0	0dB
ZEROFREQ	200	-2dB	0.00	0 255	0.00 10 REF	0.00 10dB
FASTSWP	200	-4dB	0.00	0 255	20	20dB
SLOWSWP	200	-8dB	0.00	0 255	30	30dB
FM SWPSENS	200	-16dB	0.00	0 255	40	40dB
MAIN SWPSENS		BND 0		-9kHz - 0	50	50dB
MEDSWP		BND 1		-300kHz - 0	10	60dB
FM COILSENS		BND 2		-1kHz - 0	20	60dB
GATCAL		BND 3		-3kHz - 0	30	70dB
0		BND 4		-10kHz - 0	40	
MAIN COILSENS	200			-30kHz - 0		
0	200	0.00		-100kHz - 255		
PKDETOFS	200	0.00		-300kHz - 255		
1	200	0.00		-1MHz - 255		
1	200	0.00		-3MHz - 255		
85	200	0.00		-5MHz - 255		
	RTXO DAC	0.00		-120kHz - 255		

Figure 10-3. Calibration Data Map

The following text describes each column of correction data illustrated in Figure 10-3. The sections of Figure 10-3 that contain numbers retain data that is the same for all analyzers; the data is stored in memory at the factory and cannot be changed.

- **MISC FREQ.** These miscellaneous frequency correction values correct for variations in instrument hardware performance.
- **RL-VENR.** The reference-level-vernier error corrections are DAC values that calibrate the reference level at top-screen during the **CAL AMPTD** self-calibration routine.

The first five entries are fixed constants.

The second five entries provide a coarse gain-adjustment of the A9 Third Converter assembly. Only one DAC value is produced by the calibration routine and is duplicated for all five entries.

The A7 Analog Interface assembly uses the DAC value to adjust the gain of the A9 assembly. The DAC adjustment range is from 0 to 255. The higher the DAC value, the greater the gain on the A9 assembly. Refer to the **CAL AMPTD** softkey description for more information.

- **RTXO DAC.** The DAC value adjusts the 10 MHz frequency reference on the A25 Counter Lock assembly. Refer to the 10 MHz Reference (Standard) adjustment procedure in Chapter 2.
- **ERR.** These error corrections are mathematical offsets of the digitized video signal on the A16 Processor/Video assembly.

The first five entries in the "ERR" column are correction constants that correct amplitude errors for the calibration attenuators on the A12 Amplitude Control assembly. Currently, the entry for the 16 dB attenuator is not used.

The calibration attenuators are the amplitude reference for the **CAL AMPTD** self-calibration routine. The five constants are stored in nonvolatile memory initially at the factory. The constants can be retrieved from, and restored to, nonvolatile memory using the procedures in "Backing-Up Analyzer Correction Constants" in Chapter 9. When required, new constants are produced using the Cal Attenuator adjustment procedures in Chapter 2.

Refer to the **SET-ATTN** softkey description for more information about the calibration attenuators on the A12 assembly.

The second five entries in the "ERR" column are one correction factor that provides a fine adjustment of the reference-level during the **CAL AMPTD** self-calibration routine. The calibration routine produces one video offset and stores it for all five entries.

The video offset is used to make a fine reference-level adjustment after a coarse reference-level adjustment is done using the DAC correction values from "RL-VENR".

- **BW-AMP.** The bandwidth amplitude corrections are mathematical offsets of the digitized video signal on the A16 Processor/Video assembly. Refer to the **CAL AMPTD** softkey description for more information.
- **LC-XTAL.** The A7 Analog Interface assembly uses these DAC values to adjust the bandwidths of the 21.4 MHz crystal and LC bandwidth filters on the A11 and A13 Bandwidth Filter assemblies. The **CAL AMPTD** self-calibration routine produces DAC values that adjust each bandwidth to within $\pm 20\%$.

The 9 kHz and 120 kHz entries are for the 6 dB EMI resolution bandwidths. All other entries are for the 3 dB resolution bandwidths.

Refer to the **CAL AMPTD** softkey description for more information.

- **SGAIN.** The step-gain and linear-gain corrections are mathematical offsets of the digitized video signal on the A16 Processor/Video assembly.

The first six entries in the "SGAIN" column are for the 10 dB step gains on the A12 Amplitude Control assembly. The **CAL AMPTD** self-calibration routine uses the 10 dB step gain as an amplitude reference while calibrating the step gains.

The last four entries in the "SGAIN" column are for the 10 dB linear gains on the A14 Log Amplifier assembly.

Refer to the **CAL AMPTD** softkey description for more information about the calibration of the step-gain and linear-gain stages. Refer to "IF Section Gain Control" in Chapter 8 to identify the gain stages that are in use for a given reference-level setting.

- **RFATN**. The input attenuator corrections are mathematical offsets of the digitized video signal on the A16 Processor/Video assembly. The 10 dB attenuator step is the amplitude reference used by the **CAL AMPTD** self-calibration routine while calibrating the input attenuator. Refer to the **CAL AMPTD** softkey description for more information about the calibration of the input attenuators.

Refer to "Control of the A3A5 Input Attenuator" in Chapter 7 to identify the attenuators that are in use for a given input attenuation setting.

**RELATED
SOFTKEYS**

CAL FREQ

CAL AMPTD

DEFAULT CAL DATA

CAL STORE

CAL FETCH

SET ATTN ERROR

CAL TIMEBASE

DROOP Droop

DESCRIPTION

Droop disables the reset of the peak detector on the A16 Processor/Video assembly after each analog-to digital conversion. When an impulse signal is applied, the decrease, or droop, in the peak-detector output is visible. The peak detector will charge up to the peak value of the input signal and then its amplitude will decrease over time.

Refer to the "Locating an RF/LO/IF or Video Problem" in Chapter 6 for additional troubleshooting information about the peak detector.

**RELATED
SOFTKEYS**

CONF TEST

EDIT FLATNESS Edit Flatness

DESCRIPTION

Note



To safeguard the current flatness-correction constants, refer to “Backing Up Analyzer Correction Constants” in Chapter 9 before using this function.

The flatness-correction constants can be viewed or modified using **EDIT FLATNESS**.

- To view the flatness-correction constants, do not enter the passcode before proceeding to **EDIT FLATNESS**.
- To edit the flatness data, enter the -2001 Hz passcode, press **CAL** and proceed to **EDIT FLATNESS**.
 1. After pressing **EDIT FLATNESS**, the **STORE FLATNESS** softkey appears, and the flatness data is ready for editing.
 2. Use the A1A2 knob, the **↑** key, or the **↓** key to move along the frequency band of the analyzer.
 3. Enter the amplitude offset for the desired frequency point and terminate the entry with **-dBm** or **+dBm**.
 4. Store the flatness constants by pressing **STORE FLATNESS**; the new correction constants are stored and an instrument preset is performed.
- Exit the routine at any time by pressing **EXIT**; no changes are made to the existing correction constants and an instrument preset is performed.

Refer to the Frequency Response adjustment procedures in Chapter 2 for complete instructions related to the flatness-correction constants.

RELATED SOFTKEYS

INIT FLT

STORE FLATNESS

FLATNESS DATA

CAL MXR

EXIT

EXECUTE TITLE Execute Title

DESCRIPTION Use **EXECUTE TITLE** to execute remote programming commands that have been entered from the front-panel using **CHANGE TITLE**. Refer to the *HP 8594A/8595A Installation and Verification Manual* for more information about **CHANGE TITLE**.

**RELATED
SOFTKEYS** **CHANGE TITLE**

EXIT Exit

DESCRIPTION Use **EXIT** to withdraw from a softkey function. No changes are made within the function and an instrument preset is performed.

**RELATED
SOFTKEYS** **EDIT FLATNESS**

FINE TUNE DAC Fine Tune DAC

DESCRIPTION Displays the output of the YTO fine-tune DAC produced on the A7 Analog Interface assembly. The analyzer must be in a single-band sweep for the display to be valid. When **FINE TUNE DAC** is selected, a horizontal line is displayed in the lower four divisions of the screen. The line represents the 0 V to -10 V DAC output voltage. When the YTO DAC voltage becomes more negative, the YTO frequency is increased, and the displayed line moves lower on-screen.

Refer to Chapter 7 for additional LO troubleshooting information.

**RELATED
SOFTKEYS** **COARSE TUNE DAC**

FLATNESS DATA Flatness Data

DESCRIPTION Provides access to the softkeys used for viewing or editing the flatness correction constants. The -2001 Hz passcode is required when editing the correction data.

**RELATED
SOFTKEYS** **EDIT FLATNESS**
STORE FLATNESS
INIT FLT

FM COIL DRIVE FM Coil Drive

DESCRIPTION Displays the output of the FM Coil Driver produced on the A7 Analog Interface assembly.

Perform the following steps to observe the output of the FM coil driver for the FM spans (LO spans less than or equal to 10 MHz):

1. Activate **SPAN** before pressing **CAL** to select the **FM COIL DRIVE** function.
2. Press **FM COIL DRIVE** to display a positive-going ramp.
3. Adjust the span setting while observing the displayed ramp. The slope of the ramp increases as the span is increased.

Due to quantization errors, the display appears flat for LO spans less than 500 kHz. For the main-coil spans (LO spans greater than 10 MHz) the display is a flat line.

Refer to Chapter 7 for additional LO troubleshooting information.

**RELATED
SOFTKEYS** **FM SPAN**
FINE TUNE DAC
X FINE TUNE DAC

FM GAIN FM Gain

Note



This function is available for instruments equipped with Option 102, AM/FM Speaker and TV Sync Trigger, only.

DESCRIPTION

This softkey duplicates the functions of the **FM GAIN** key that is accessed using **AUX CTRL**. **FM GAIN** adjusts the top-to-bottom screen deviation range of a demodulated FM signal, referenced to center-screen. The **CAL FREQ** self-calibration routine calibrates the FM screen deviation and modulation offset.

Use **FM GAIN** to do a functional check of the demodulation circuitry. The CAL OUT signal can be used in place of a FM modulated signal source.

1. Connect the CAL OUT signal to the analyzer input and make the following instrument settings:

PRESET
FREQUENCY 300 MHz
CF STEP AUTO MAN (MAN) 500 kHz
SPAN 0 Hz
BW 5 **MHz**
AMPLITUDE -20 dBm

2. Press the following keys:

AUX CTRL
DEMOD
DEMOD ON OFF (ON)
DEMOD AM FM (FM)
FM GAIN

When **FM GAIN** is first enabled, it has a 100 kHz deviation from center-screen.

3. Set the maximum deviation from center screen by entering 500 kHz using the data keys, the A1A2 knob, or the **↑** and **↓** keys.
4. Simulate a 500 kHz modulated signal by pressing the following keys:

FREQUENCY
↑

If **FM GAIN** is functioning correctly, the displayed signal is deflected from center screen to bottom screen as the center frequency is stepped up 500 kHz from the original center frequency setting.

5. Press the **⇩** key twice. The displayed signal moves from bottom-screen to top-screen as the center frequency is stepped down 500 kHz from the original center frequency.

RELATED
SOFTKEYS

DEMOD

DEMOD AM FM

FM OFFSET

FM OFFSET FM Offset

Note



This function is available for instruments equipped with Option 102, AM/FM Speaker and TV Sync Trigger, only.

DESCRIPTION

Use **FM OFFSET** to adjust the horizontal trace for center-screen with no modulation on the carrier. This function is useful for adjusting the carrier offset when **FM GAIN** is set for a modulated signal with a small frequency deviation. The **CAL FREQ** self-calibration routine calibrates an initial center-screen offset.

Use **FM OFFSET** to do a functional check of the demodulation circuitry. The CAL OUT signal can be used in place of an unmodulated carrier signal.

1. Connect the CAL OUT signal to the analyzer input and make the following instrument settings:

PRESET

FREQUENCY 300 MHz

SPAN 0 Hz

BW 5 **MHz**

AMPLITUDE -20 dBm

2. Press the following keys:

AUX CTRL

DEMOD

DEMOD ON OFF (ON)

DEMOD AM FM (FM)

CAL

MORE 1 of 3

MORE 2 of 3

SERVICE DIAG

MORE 1

MORE 2

MORE 3

MORE 4

FM OFFSET

3. Adjust the position of the horizontal trace to center-screen using the A1A2 knob.
4. To calculate the actual frequency offset in kHz, multiply the displayed value by 300.

**RELATED
SOFTKEYS**

DEMOD

DEMOD AM FM

FM GAIN

FM SPAN FM Span

DESCRIPTION Displays the FM_SPAN signal from the Span Dividers on the A7 Analog Interface assembly.

Perform the following steps to observe the FM-SPAN signal for FM spans (LO spans less than or equal to 10 MHz):

1. Activate **SPAN** before pressing **CAL** to select the **FM SPAN** function.
2. Press **FM SPAN** to display a negative-going ramp.
3. Adjust the span setting while observing the displayed ramp. The slope of the ramp increases as the span is increased.

Due to quantization errors, the display appears flat for LO spans less than 500 kHz.

For the main-coil spans (LO spans greater than 10 MHz) the display is a flat line.

Refer to Chapter 7 for additional LO troubleshooting information.

**RELATED
SOFTKEYS**

MAIN SPAN

FREQ DIAG Frequency Diagnostics

DESCRIPTION

Displays, in real-time, frequency diagnostic information for the LO section. Refer to Figure 10-4 for the location of each block of frequency data.

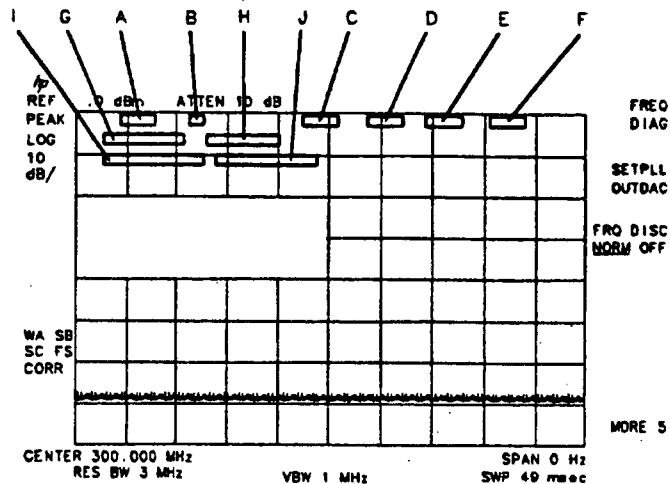

Figure 10-4. LO Frequency Diagnostic Data Display

- A The calculated coarse-tune DAC value.
- B The desired sampling-oscillator harmonic.
- C The error, in Hz, between the sampler IF frequency (H) and the actual frequency counted at the sampler IF.
- D The actual coarse-tune DAC value (0 to 4095).
- E The actual fine-tune DAC value (0 to 4095).
- F The actual extra-fine-tune DAC value (0 to 4095).
- G The sampling-oscillator frequency in Hz.
- H The sampler IF frequency in Hz.
- I Multiply this value by the main-coil sensitivity (J) to yield the FM coil sensitivity in bits/Hz.
- J The main-coil sensitivity in bits/Hz.

Refer to Chapter 7 for additional LO troubleshooting information.

RELATED SOFTKEYS

DISPLAY CAL DATA

FRQ DISC NORM OFF Frequency Discriminator Normal/Off

- DESCRIPTION** Indicates the status of the frequency discriminator as a function of LO span.
- In LO spans less than or equal to 10 MHz, **NORM** should be underlined, indicating the discriminator is in use.
 - In LO spans greater than 10 MHz, **OFF** should be underlined, indicating the discriminator is not in use.

GND REF DETECTOR Ground-Reference Detector

DESCRIPTION Displays the output of the analog-ground reference produced on the A16 Processor/Video assembly. A horizontal line at the bottom graticule line indicates that the ADC is adjusted correctly. The ground reference is produced on the A16 Processor/Video assembly.

The **CAL AMPTD** self-calibration routine uses the analog-ground reference to calibrate the bottom-screen level of the main ADC on the A16 Processor/Video assembly.

Note



During **PRESET** the analog-ground and +2 V signal are used to calibrate the main ADC. The analog ground and 2 V reference at the input MUX are used during calibration. If the signals are out of range, the **ADC-GND FAIL** or **ADC-2V FAIL** error messages are displayed.

**RELATED
SOFTKEYS**

CAL AMPTD

IDNUM Identification Number

DESCRIPTION Selects the identity of the spectrum analyzer. There is one firmware set for the HP 8592B, HP 8593A, HP8594A, and HP 8595A spectrum analyzers. By selecting the appropriate identification number (**IDNUM**), the firmware configures the analyzer to the proper frequency range and analyzer functions.

The following table shows the relationship between the **IDNUM** and the spectrum analyzer model number.

IDNUM	Spectrum Analyzer
3	HP 8592B/8593A
4	HP 8594A
5	HP 8595A

Refer to "Analyzer Recovery after a A16 Memory Loss" in Chapter 9.

RELATED
SOFTKEYS

INIT FLT

INIT FLT Initialize Flatness

DESCRIPTION

Prepares the analyzer memory for the entry of new flatness correction constants. The -2001 Hz passcode is required and must be entered before pressing **CAL**.

INIT FLT performs the following functions:

- Sets up the start frequency, stop frequency, and step size of the frequency-response-correction points up to 6.5 GHz.
- Initializes A16 memory by entering a default value of 0 dB into memory for all frequency points.

Caution

The current flatness-correction constants are lost when **INIT FLT** is pressed.



RELATED
SOFTKEYS

EDIT FLATNESS

STORE FLATNESS

MAIN COIL DR Main-Coil Drive

DESCRIPTION

Displays the output of the main-coil driver produced on the A7 Analog Interface assembly. The instrument must be in a single-band sweep for the display to be valid.

Perform the following steps to observe the output of the main-coil driver:

1. Activate either **SPAN** or **CENTER FREQ**, as needed.
2. Press **CAL** to select the **MAIN COIL DR** function.
3. Change either the span or center-frequency setting and observe the displayed signal.

- When the span setting is increased (For LO spans greater than 10 MHz), the positive slope of the displayed ramp increases.

Due to quantization errors, the display appears flat for LO spans less than 500 MHz.

- When the center frequency setting is increased within a band, the vertical position of the ramp moves up the screen. The vertical position of the ramp is a function of the YTO tune frequency.

The combination of the ramp slope and vertical position represents a voltage that is proportional to the current in the A3A7 YTO main coil.

Refer to Chapter 7 additional LO troubleshooting information.

RELATED SOFTKEYS

FM COIL DRIVE

MAIN SPAN Main Span

DESCRIPTION

Displays the main-coil-span signal, MC_SPAN, from the span dividers on the A7 Analog Interface assembly. The instrument must be in a single-band sweep for the display to be valid.

Perform the following steps to observe MC_SPAN for the main-coil spans (LO spans greater than 10 MHz):

1. Press **SPAN** before pressing **CAL**.
2. Press **MAIN SPAN** to display a negative-going ramp.
3. Adjust the span setting while observing the displayed ramp. The slope of the ramp increases as the span increases.

Due to quantization errors, the display appears flat for LO spans less than 100 MHz. For FM coil spans (LO spans less than or equal to 10 MHz), the display is a flat line.

Refer to Chapter 7 for additional LO troubleshooting information.

RELATED
SOFTKEYS

FM SPAN

MIXER BIAS DAC Mixer-Bias DAC

DESCRIPTION

Displays the output of the mixer-bias DAC from the first-converter driver on the A7 Analog Interface assembly. This DAC provides a bias current for the high-band mixer in the A3A6 Dual-Band Mixer. The instrument must be in a single-band sweep for the display to be valid.

The top four display divisions represent the DAC range of 0 V to +10 V. A horizontal line, representing the DAC output voltage, is displayed within the top four divisions. The DAC voltage should not change within a frequency band.

Refer to Chapter 7 for additional troubleshooting information.

RELATED
SOFTKEYS

CAL MIR

PRESEL DAC Preselector DAC

DESCRIPTION

Peaks the YTF preselector by manually adjusting the YTF fine-tune DAC. The front-panel entry range for the DAC is from 1 to 3840.

The analyzer firmware adds the entered value to an 8-bit value (0 to 255), yielding a result between 1 and 4095. This result then drives the 12-bit YTF fine-tune DAC.

Note



Use either **PRESET** or **PRESEL DEFAULT** to set the **PRESEL DAC** to an initial value of 2048.

RELATED
SOFTKEYS

CAL YTF

PRESEL DEFAULT

QP DET ON OFF Quasi-Peak Detector On/Off

DESCRIPTION **QP DET ON OFF** turns the quasi-peak detector on or off.

RELATED **QP GAIN ON OFF**
SOFTKEYS

QP RST ON OFF

QPD OFFSET

QP GAIN ON OFF Quasi-Peak GAIN On/Off

DESCRIPTION **QP GAIN ON OFF** amplifies the video signal ten times (20 dB).

Note  The reference level offset is not changed. The marker readout and reference level readout must be divided by 10 to obtain the correct amplitude readout.

RELATED **QP DET ON OFF**
SOFTKEYS

QP RST ON OFF

QPD OFFSET

QPD OFFSET Quasi-Peak Detector Offset

DESCRIPTION Sets the offset of the quasi-peak detector.

Note  For accurate quasi-peak measurements, **QPD OFFSET** should be set to a value of 29. The quasi-peak detector offset is set to a value of 29 by pressing **PRESET**.

RELATED **QP DET ON OFF**
SOFTKEYS

QP GAIN ON OFF

QPD RST ON OFF

QPD RST ON OFF Quasi-Peak Detector Reset On/Off

DESCRIPTION **QPD RST ON OFF** discharges and resets the quasi-peak detector.

**RELATED
SOFTKEYS** **QP DET ON OFF**

QP GAIN ON OFF

QPD OFFSET

SERVICE CAL Service Calibration

DESCRIPTION Provides access to the service-softkey functions.

**RELATED
SOFTKEYS** Refer to Figure 10-1.

SERVICE DIAG Service Diagnostics

DESCRIPTION Provides access to the service-diagnostic softkey functions. For selected service softkeys, an abbreviation for the active service function appears in the detector display block. The display block is located in the upper left-hand corner of the display.

**RELATED
SOFTKEYS** Refer to Figure 10-1.

SET ATTN ERROR Set Attenuator Error

DESCRIPTION

Note



To avoid losing correction-constant data, make a backup copy of all correction data before servicing the analyzer. Refer to **DISPLAY CAL DATA** and **EDIT FLATNESS** for the location of the correction data.

The step attenuators on the A12 Amplitude Control assembly are the relative amplitude reference for the **CAL AMPTD** routine. Four of the five step attenuators (the 1 dB, 2 dB, 4 dB, and 8 dB steps) are used. Currently, the 16 dB attenuator step is not used.

If the factory-loaded attenuator-correction constants are no longer valid, new attenuator-correction constants must be developed for the following circumstances:

- A new A12 Amplitude Control assembly is installed.
- A new A16 Processor/Video assembly is installed.
- The battery-backed nonvolatile memory contains errors caused by any one of the following:
 - A dead BT101 battery.
 - Correction data accidentally altered by the user after he has entered the passcode and gained access to the SERVICE CAL softkeys.
 - Defective hardware on the A16 assembly.

Use the "Cal Attenuator Error Correction" section of Chapter 2 to characterize the four attenuator steps and produce new attenuator correction constants.

Enter the new correction constants into A16 RAM with the following procedure:

1. Press the following keys:

PRESET

FREQUENCY -2001 Hz

SET ATTN ERROR

2. The data-entry instruction for the 1 dB step, ENTER CAL ATTN ERROR 1, is displayed in the active-function block, just below the active entry for the reference-level-offset value, REF LVL OFFSET.
3. Enter the characterization data for the 1 dB, 2 dB, 4 dB, and 8 dB steps, with a 0.01 dB resolution for each entry.
4. Terminate each entry with either the +dBm or -dBm key.
5. Enter the original factory value, or a default value of 0 dBm, for the 16 dB step.

After each entry the characterized value is displayed, with 0.1 dB resolution, to the left of the graticule, followed by the offset-reference-level indicator, OFFSET.

If desired, use DISPLAY CAL DATA to review the new attenuator-characterization data with 0.01 dB resolution. Refer to DISPLAY CAL DATA for an explanation of the displayed calibration data.

RELATED
SOFTKEYS

CAL AMPTD

DISPLAY CAL DATA

SETPLL OUTDAC Set PLL Out DAC

DESCRIPTION Allows the sampling-oscillator frequency to be set manually. Use the following steps to change the sampling-oscillator frequency.

1. Divide the desired sampling-oscillator frequency by 150 kHz.
2. Enter the value and press **ENTER**.

Refer to Chapter 7 for additional LO troubleshooting information.

**RELATED
SOFTKEYS**

FREQ DIAG

STOR PWR ON UNITS Store Power-On Units

DESCRIPTION Allows the user to change the amplitude display units that appear at instrument power-on or when **PRESET** is pressed. The units must be changed for both log and linear mode.

The following amplitude display units can be selected: dBm, dBmV, dB μ V, Volts, and Watts. For example, press the following keys to set the analyzer power-on units to read out in dBmV in log mode and volts in linear mode.

PRESET

FREQUENCY -2001 **Hz**

AMPLITUDE **MORE 1 of 2** **INPUT Z** (50)

AMPLITUDE **SCALE LOG LIN** (LOG) **MORE 1 of 2** **AMPTD UNITS**
dBmV

AMPLITUDE **SCALE LOG LIN** (LIN) **MORE 1 of 2** **AMPTD UNITS**
Volts

AMPLITUDE **SCALE LOG LIN** (LOG)

CAL **MORE 1 of 3** **MORE 2 of 3** **SERVICE CAL** **STOR PWR ON UNITS**

Note



Selecting **INPUT Z** (50) ensures that the analyzer will make amplitude calculations based on a 50 Ω system. Changing **INPUT Z** does not affect the input impedance of the analyzer.

To return the analyzer to the standard power-on settings, use the procedures in "After Replacing the A16 Processor/Video Board Assembly" in Chapter 3.

STORE FLATNESS Store Flatness

DESCRIPTION

Note The **STORE FLATNESS** softkey is accessible only after entering the -2001 Hz passcode prior to pressing the **CAL** and **EDIT FLATNESS** softkeys.



After entering new flatness-correction constants, use **STORE FLATNESS** to store them in nonvolatile memory.

RELATED SOFTKEYS

EDIT FLATNESS

STP GAIN ZERO Step-Gain Zero

DESCRIPTION

Disables the two 20-dB step-gain amplifiers on the A12 Amplitude Control assembly. While disabled, the A12 assembly provides the same gain for all reference-level settings of -10 dBm and below. The two amplifiers are disabled as part of the A14 Log Amplifier adjustment procedure in Chapter 2. Use **PRESET** to reset the step-gain amplifiers.

SWEEP RAMP Sweep Ramp

DESCRIPTION

Displays the RAMP signal from the Sweep-Ramp Generator on the A7 Analog Interface assembly.

The RAMP signal has a range of -10 V to +10 V. A positive-going ramp extending from the lower-left corner of the screen to the upper-right corner represents a normal RAMP signal.

Refer to Chapter 7 for additional troubleshooting information.

SWEEP TIME DAC Sweep-Time DAC

DESCRIPTION Displays the output of the sweep-time DAC, SWP_DAC, from the sweep-ramp generator on the A7 Analog Interface assembly. The top graticule represents +10 V and the bottom represents -10 V.

The instrument must be in a single-band sweep for the display to be valid.

The sweep times are grouped into three ranges:

- 20 milliseconds to less than 300 milliseconds.
- 300 milliseconds to less than 6 seconds.
- 6 seconds to 100 seconds.

Within each range, a negative voltage is displayed and becomes more negative as the sweep time is decreased.

Refer to "A7 Analog Interface Assembly" in Chapter 9 for further troubleshooting information.

**RELATED
SOFTKEYS**

SWEEP RAMP

VERIFY TIMEBASE Verify Timebase

DESCRIPTION

Note



Instruments equipped with Option 004, Precision Frequency Reference, do not use this softkey function.

Allows the DAC value for the 10 MHz timebase to be changed temporarily. Either the -37 Hz or the -2001 Hz passcode must be entered to activate this function.

This function is used to verify the settability specification for the timebase. Refer to the 10 MHz Reference Accuracy (Standard Timebase) verification test in the *HP 8594A/8595A Installation and Verification Manual*.

**RELATED
SOFTKEYS**

CAL TIMEBASE

X FINE TUNE DAC Extra-Fine Tune DAC

DESCRIPTION Displays the output of the YTO extra-fine-tune DAC, FM_TUNE, on the A7 Analog Interface assembly.

The instrument must be in a single-band sweep for the display to be valid.

The lower four divisions of the screen represent a 0 to -10 V output range. Midscreen represents 0 V and bottom-screen represents -10 V. The DAC voltage level is displayed as a horizontal line within the four divisions.

Refer to Chapter 7 for additional LO troubleshooting information.

**RELATED
SOFTKEYS**

COARSE TUNE DAC

FINE TUNE DAC

DACS

YTF DRIVER YTF Driver

DESCRIPTION Displays the output of the sample-and-hold circuit in the YTF span divider and driver on the A7 Analog Interface assembly. This signal is then converted to a current to drive the YTF.

The instrument must be in a single-band sweep for the display to be valid.

The lower four divisions of the screen represent a 0 to -10 V output range. Midscreen represents 0 V and bottom-screen represents -10 V.

A ramp is displayed for all spans except zero span. In zero span, a horizontal line is displayed.

The displayed voltage is the sum of the YTF fine-tune DAC, YTF coarse-tune DAC, and YTF span voltages. The voltage becomes more negative as the tuned frequency increases.

Refer to Chapter 7 for further troubleshooting information.

**RELATED
SOFTKEYS**

YTF TUNE COARSE

YTF TUNE FINE

YTF SPAN

YTF TUNE COARSE YTF Tune Coarse

DESCRIPTION Displays the output of the YTF coarse-tune DAC produced on the A7 Analog Interface assembly.

The instrument must be in a single-band sweep for the display to be valid.

The lower four divisions of the screen represent a 0 to -10 V output range. Midscreen represents 0 V and bottom-screen represents -10 V.

The DAC voltage level is displayed as a horizontal line within the four lower divisions. The voltage becomes more negative as the center frequency is increased. Refer to Chapter 7 for further troubleshooting information.

**RELATED
SOFTKEYS**

YTF TUNE FINE

YTF DRIVER

YTF SPAN

YTF TUNE FINE YTF Tune Fine

DESCRIPTION Displays the output of the YTF fine-tune DAC on the Analog Interface assembly. This DAC voltage provides only fine adjustment of the YTF tuning; there is no direct correlation between the DAC voltage and the center-frequency setting.

The instrument must be in a single-band sweep for the display to be valid.

The lower four divisions of the screen represent a 0 to -10 V output range. Midscreen represents 0 V and bottom-screen represents -10 V.

The DAC voltage level is displayed as a horizontal line within the four lower divisions.

Refer to Chapter 7 for further troubleshooting information.

**RELATED
SOFTKEYS**

YTF TUNE COARSE

PRESEL DAC

PRESEL DEFAULT

YTF SPAN YTF Span

DESCRIPTION

Displays the output of the YTF span divider, YTF_SPAN, on the A7 Analog Interface assembly.

The analyzer must be in a single-band sweep for the display to be valid. The swept range of the A3A2 Switched YTF cannot exceed 7 GHz.

Perform the following steps to observe YTF_SPAN:

1. Press **SPAN** before pressing **CAL**.
2. Press **YTF SPAN** to display a negative-going ramp, centered about the center horizontal graticule.
3. Adjust the span setting while observing the displayed ramp. The slope of the ramp increases as the span is increased.
4. Press **YTF SPAN** after each change in span setting.

For spans of less than 200 MHz, the display appears flat, due to quantization errors.

Refer to Chapter 7 for further troubleshooting information.

RELATED SOFTKEYS

YTF TUNE COARSE

YTF TUNE FINE

YTF DRIVER

Analyzer Messages

Introduction

Refer to this chapter for information about hardware-error and informational messages that are displayed when a problem with the operation of the analyzer occurs.

Refer to the *HP 8594A/8595A Installation and Verification Manual* for information about user-created error messages.

Interpreting Analyzer Messages

The analyzer firmware displays error messages and informational prompts to warn the user of instrument failure or improper use.

There are three types of messages: hardware-error messages (H), informational messages (M), and user-created error messages (U).

- Hardware-error messages indicate that the firmware has detected a fault in the analyzer hardware.
- Informational messages provide prompts or messages to inform the user of the analyzer status during a specific routine.
- User-created error messages indicate the analyzer is being used incorrectly. They are usually generated during remote operation.

Chapter Organization

Each analyzer message is listed in alphabetical order. The following information is provided, where applicable:

- The message type, identified by an H, M, or U.
- An operational definition for each analyzer message.
- The related analyzer assembly, or assemblies, that is the likely cause of the problem defined by the hardware-error message.
- Relevant troubleshooting hints.

ADC-GND FAIL (H)

Description

During an instrument preset, the analog-to-digital converter reading for ground on the A16 Processor/Video assembly is outside the test limit. An instrument preset routine is also performed during the self-calibration routines.

Related Assemblies

A7 Analog Interface, A8 Power Supply, A15 Motherboard, A16 Processor/Video, assemblies installed in the card cage

Troubleshooting Hints

The +15 V and -15 V supplies from the A8 Power Supply can cause this error message. If the power-supply LEDs for both power supplies are on, check that the supplies are within tolerance using the test points on the A16 Processor/Video assembly. If the supplies are not within tolerance, refer to "Problems at Instrument Power-Up" in Chapter 6.

A voltage greater than +10 V dc on pins 1, 3, 5, 7, or 31 of A16J1 can cause this error message. Refer to Figure 11-1 for the numbering order of the A16J1 connector pins that are accessible from the component side of the A16 assembly. If a voltage greater than +10 V is present on any one of the A16J1 pins indicated, use Table 11-1 to locate the source of the error message.

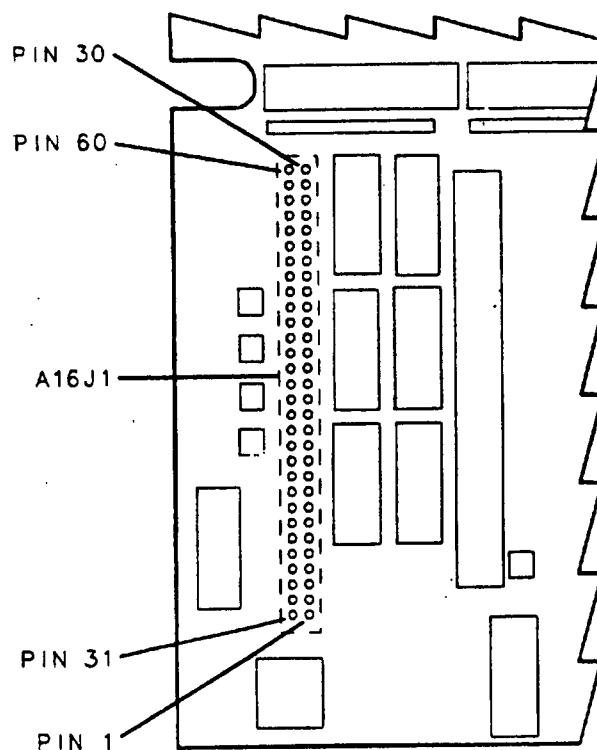

Figure 11-1. A16J1 Connector-Pin Orientation

Table 11-1. Possible Cause of the Error Message "ADC-GND FAIL"

A16J1 Pin Number	Possible Error-Message Source
1	A14 Log Amplifier assembly An assembly installed in the card cage
3	An assembly installed in the card cage
5	An assembly installed in the card cage
7	A16 Processor/Video assembly An assembly installed in the card cage Signal incorrectly applied to the AUX VIDEO output
31	A7 Analog Interface

Before removing the A16 Processor/Video assembly, check all assemblies that are identified in Table 11-1.

1. Turn the instrument power off and remove each assembly, one at a time.
2. Turn the instrument on.
 - If the ADC ground fault remains, the instrument preset at power-up displays the error message.
 - If the error message goes away, the last assembly removed is the cause of the problem.
 - If the error message remains after the removal of all related assemblies, suspect the A16 assembly.

An ADC ground failure can also be checked manually, using the service diagnostic **GND REF DETECTOR**.

ADC-TIME FAIL (H)

Description

During an instrument preset, the time between analog-to-digital conversion readings is greater than the test limit. An instrument preset routine is also performed during the self-calibration routines.

Related Assemblies

A16 Processor/Video

Troubleshooting Hints

If the instrument does not sweep, and all other instrument functions are normal, the probable cause of the error message is a defective A16 Processor/Video assembly.

ADC-2V FAIL (H)

Description

During an instrument preset, the analog-to-digital converter reading for the +2 V reference on the A16 Processor/Video assembly is outside the test limit. An instrument preset routine is also performed during the self-calibration routines.

Related Assemblies

A8 Power Supply, A15 Motherboard, A16 Processor/Video, assemblies installed in the card cage

Troubleshooting Hints

The +15 V and -15 V supplies from the A8 Power Supply can cause this problem. If the power-supply LEDs for both supplies are on, check that the supplies are within tolerance using the test points on the A16 processor assembly. If the supplies are not within tolerance, refer to "Problems at Instrument Power-Up" in Chapter 6.

A voltage greater than +10 V dc on pins 1, 3, 5, 7, or 31 of A16J1 can cause this error message. Refer to Figure 11-2 for the numbering order of the A16J1 connector pins that are accessible from the component side of the A16 assembly. If a voltage greater than +10 V is present on any one of the A16J1 pins indicated, use Table 11-2 to locate the source of the error message.

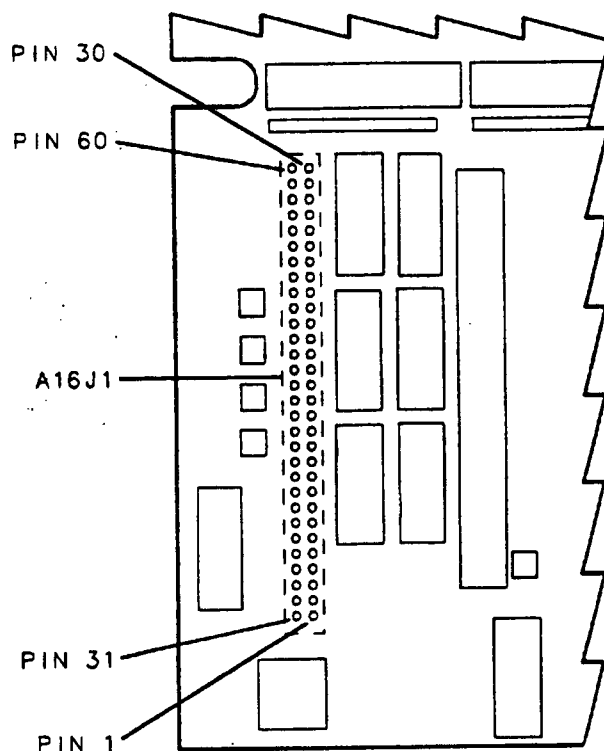

Figure 11-2. A16J1 Connector-Pin Orientation

Table 11-2. Possible Cause of the Error Message "ADC-2V FAIL"

A16J1 Pin Number	Possible Error-Message Source
1	A14 Log Amplifier assembly An assembly installed in the card cage
3	An assembly installed in the card cage
5	An assembly installed in the card cage
7	A16 Processor/Video assembly An assembly installed in the card cage Signal incorrectly applied to the AUX VIDEO output
31	A7 Analog Interface assembly

Before removing the A16 Processor/Video assembly, check all assemblies that are identified in Table 11-2.

1. Turn the instrument power off and remove each assembly, one at a time.
2. Turn the instrument on.
 - If the ADC 2 V fault remains, the instrument preset at power-up displays the error message.
 - If the error message goes away, the last assembly removed is the cause of the problem.
 - If the error message remains after the removal of all related assemblies, suspect the A16 assembly.

Check the ADC 2 V Reference Voltage on the A16 assembly. Refer to *HP 8590 Series Component-Level Information* for the location of the 2 V reference circuit in the analog-to-digital function block.

A 2 V reference failure can also be checked manually, using the service diagnostic **2V REF DETECTOR**.

CAL: - - (M)

Description

During the **CAL FREQ** and **CAL AMPTD** self-calibration routines, messages are sequentially displayed, indicating that the routine is progressing:

- **SWEEP**, **FREQ**, and **SPAN** appear during the **CAL FREQ** routine. **FM GAIN + OFFSET** also appears for instruments equipped with Option 102, AM/FM Speaker and TV Sync Trigger or Option 103, Quasi-Peak Detector/Demodulator.
- **AMPTD**, **3dB BW**, **ATTEN**, and **LOG AMP** appear during the **CAL AMPTD** routine.
- **YTF** and **PEAKING** appear during the **CAL YTF** routine.
- **MIXER BIAS** and **PEAKING** appear during the **CAL MXR** routine.

Refer to the **CAL FREQ**, **CAL AMPTD**, **CAL YTF**, and **CAL MXR** softkey descriptions in Chapter 10 for further information.

Note

It is normal for the **FREQ UNCAL** error message to appear briefly during **CAL FREQ**.

Troubleshooting Hints

If the firmware detects a problem during the self-calibration routine, the routine will stop and display an error message (H). Refer to the appropriate error-message description in this section.

CAL: DATA NOT STORED CAL AMP NEEDED (U)(H)

Description

The current correction-factor data is the default calibration data. The instrument firmware prevents the default data from being stored. While the default data is in use, a flag is set. If **CAL STORE** is pressed, the error message is displayed and **CAL STORE** is disabled. Successful completion of the **CAL AMPTD** routine clears the flag.

Related Assemblies

A16 Processor/Video

Troubleshooting Hints

Perform the **CAL FREQ**, **CAL AMPTD** and **CAL YTF** routines. If the error message reappears after pressing **CAL STORE**, the **CAL AMPTD** routine was not successfully completed.

Note



Pressing **CAL FETCH** also clears the correction-data error flag and can permit erroneous data to be stored. Use **CAL FETCH** only for troubleshooting.

CAL: cannot execute CALAMP enter: 0 dB PREAMP GAIN (U)(H)

Description

The preamplifier gain is not set to 0 dB. The preamplifier gain must be set to 0 dB for the **CAL AMPTD** routine to be performed.

Troubleshooting Hints

Reset the preamplifier gain to 0 dB using the following routines:

1. Press **EXT PREAMP** and set the preamplifier gain to 0 dB.
2. Perform the **CAL AMPTD** routine.
3. Press **CAL STORE** to store the new calibration factors and the preamplifier setting of 0 dB.

Note



PRESET does not initialize the preamp-gain setting to 0 dB.

If this message is still displayed after resetting the preamp gain, it is likely there is a failure in RAM on the A16 Processor/Video assembly.

CAL: FM SPAN SENS FAIL (H)

Description

During the **CAL FREQ** self-calibration routine the analyzer cannot set the span sensitivity of the FM coil. The output of the fine-tune DAC, located on the A7 Analog Interface assembly, is changed to move the displayed signal four divisions. If the signal does not move to within ± 1.25 divisions of the expected display position, the error message is displayed.

Related Assemblies

A3A7 YTO, A7 Analog Interface

Troubleshooting Hints

Caution



For instruments with firmware revisions 11.7.89 and 18.7.89 that *are not* equipped with Option 004, Precision Frequency Reference, the data stored in **CAL TIMEBASE** is lost whenever **DEFAULT CAL DATA** is used.

- Before using **DEFAULT CAL DATA**, manually record the current timebase data. Use **DISPLAY CAL DATA** to view the timebase value.
- After using **DEFAULT CAL DATA**, be sure to reenter the recorded timebase value. Refer to the 10 MHz Reference (standard) adjustment procedure in Chapter 2.

Use the default-calibration factors provided by a **DEFAULT CAL DATA**. If the error message disappears after replacing each related assembly, the replaced assembly is defective.

Recalibrate the analyzer using the **CAL FREQ**, **CAL AMPTD**, and **CAL YTF** routines. Refer to the description of each routine for further information.

Be sure to store the new calibration factors with **CAL STORE**.

CAL: GAIN FAIL (H)

Description

During the **CAL AMPTD** routine, the amplitude of the video signal at the ADC on the A16 Processor/Video assembly is too low. The error message appears when the reference-level-calibration DAC, located on the A7 Analog Interface assembly, has been adjusted to its maximum of 255, and the amplitude of the video signal remains below tolerance.

Related Assemblies

A3 Front End, A7 Analog Interface, A9 Third Converter, A11 Bandwidth Filter, A12 Amplitude Control, A13 Bandwidth Filter, A14 Log Amplifier

Troubleshooting Hints

The **CAL AMPTD** routine checks the amplitude of the video signal as it adjusts the A7 reference-level-calibration DAC. Normally, the video-signal amplitude should move within tolerance as the A7 DAC changes the gain of the IF calibration amplifier on the A9 Third Converter assembly. Refer to Foldout 6-1, RF Section Overall Block Diagram, and Foldout 6-2, IF/Control Overall Block Diagram, for more information.

Check the signal amplitude along the signal path from the RF input, through the IF section, to the output of the A14 Log Amplifier. Refer to "Locating an RF/LO/IF or Video Problem" in Chapter 6 for further troubleshooting information.

CAL: LOST COMB SIGNAL (U)(H)

Description

The **CAL YTF** routine cannot continue because the comb generator signal is absent or too low in amplitude.

Related Assemblies

A3A1 Comb Generator, A3A11 Step-Recovery Diode, A3A12 3dB Attenuator,
J2 Comb-Generator Output Connector

Troubleshooting Hints

This error message can be caused by using the wrong cable to perform the YTF calibration.

The Comb Generator cable supplied with the instrument must be used to perform this calibration. A BNC cable will not work for this procedure due to excessive cable loss. Refer to Table 1-4 for the part number of the Comb Generator cable.

The A3A1 comb-generator output at the input to the A3A11 Step-Recovery Diode should be greater than +26.0 dBm. If it is not, perform the A3A1 Comb Generator adjustment in Chapter 2.

CAL: PASSCODE NEEDED (M)

Description

The service function executed cannot be performed without the service passcode.

Troubleshooting Hints

Before performing any function that requires a service passcode, be sure you understand the consequences of the function. Improper use of functions that require a passcode can delete factory correction constants that are difficult to replace.

Refer to "Passcodes" in Chapter 10 for information about the proper use of the passcodes.

CAL: RES BW AMPL FAIL (H)

Description

During the **CAL AMPTD** routine, the insertion loss of a resolution bandwidth filter, relative to the amplitude of the 3 kHz resolution bandwidth filter, was greater than 2.2 dB.

Related Assemblies

A7 Analog Interface, A11 Bandwidth Filter, A13 Bandwidth Filter, A14 Log
Amplifier/Detector

Troubleshooting Hints

The **CAL AMPTD** routine will stop at the resolution bandwidth that failed. If the A11/A13 Bandwidth Filter assemblies require realignment, use the Crystal and LC Bandwidth Filter adjustment procedures in Chapter 2.

If a defective bandwidth filter board is suspected, refer to the "IF Power-Levels at Measurement Points" in Chapter 6 and "Bandwidth Control Lines for the A11 and A13 Bandwidth Filter Assemblies" in Chapter 8.

CAL SIGNAL NOT FOUND (U)(H)

Description

During a self-calibration routine, the CAL OUT signal cannot be found. The primary purpose of the CAL OUT check is to confirm that CAL OUT is connected to the input. A CAL OUT signal that is not within 300 MHz \pm 50 MHz, or is not greater than or equal to -45 dBm, causes this error message to be displayed.

Related Assemblies

A7 Analog Interface, A9 Third Converter

Troubleshooting Hints

If one of the following conditions are present, the error message is displayed:

- The CAL OUT signal is missing. Ensure that the CAL OUT is connected to the input connector using the Cal Out cable supplied with the analyzer.

Refer to Table 1-4 for the part number of the Cal Out cable.

If the calibration cable is connected properly, manually check the CAL OUT signal.

- The CAL OUT signal is not within \pm 50 MHz of 300 MHz, or it has an amplitude less than or equal to -45 dBm. The test limits are large enough to indicate an obvious failure for either the CAL OUT signal or the spectrum analyzer.
- The **DEFAULT CAL DATA** is in use and the frequency of the CAL OUT signal appears out of tolerance.

The default data introduces frequency offsets that can make an accurate CAL OUT signal appear to be outside the test limits for the CAL OUT check. If desired, the instrument CAL OUT check can be bypassed. Enter the -37 Hz passcode before pressing **CAL** and the desired self-calibration softkey.

Refer to the description of **DEFAULT CAL DATA** in Chapter 10 for additional information.

- The analyzer has extremely low gain. Refer to "Locating an RF/LO/IF or Video Problem" in Chapter 6.

Be sure to perform all internal self-calibration routines after resolving the calibration signal problem. Refer to the *HP 8594A/8595A Installation and Verification Manual*.

CAL: SPAN SENS FAIL (H)

Description

During the **CAL_FREQ** self-calibration routine the main-coil span-sensitivity adjustment routine has failed, indicating that the spans controlled by the main coil (LO spans greater than 10 MHz) are not working correctly. The span-sensitivity adjustment routine checks for three displayed signals: 0 Hz, 300 MHz, and 600 MHz. If three signals are not found in a 750 MHz span, the error message is displayed.

Related Assemblies

A7 Analog Interface, A3A7 YTO, A9 Third Converter, A16 Processor/Video

Troubleshooting Hints

Spurious signals can cause this routine to fail.

Refer to the **MAIN_SPAN** softkey description for further information in Chapter 10.

CAL: USING DEFAULT DATA (M)

Description

The **CAL_AMPTD** routine was not completed and default correction factors are being used.

Troubleshooting Hints

Interruption of the **CAL_AMPTD** routine can cause the routine to terminate and produce this message.

Refer to Chapter 10 for more information about **DEFAULT_CAL_DATA**.

COMB SIGNAL NOT FOUND (U)(H)

Description

During the **CAL_YTF** self-calibration routine, the comb signal cannot be found.

Related Assemblies

A3A1 Comb Generator, A3A11 Step Recovery Diode, A3A12 3dB Attenuator,
J2 Comb-Generator Output Connector

Troubleshooting Hints

- Make sure that the 100 MHz COMB OUT is connected to the analyzer input using the Comb Generator cable (SMA to Type N) supplied with the analyzer. (A Comb Generator cable (SMA to SMA) is supplied with Option 026 instruments.)
- Perform the following steps to verify the comb-generator output manually:

1. Press the following keys:

PRESET

FREQUENCY 100 **MHz**

SPAN 500 **MHz**

2. Look for the 100 MHz comb-generator signal to the right of the local oscillator signal. When **COMB GEN ON OFF** is OFF, this signal has an amplitude of approximately -8 dBm and the 100 MHz harmonics are less than -20 dBc.
3. Press the following keys:

AUX CTRL

COMB GEN ON OFF (On)

4. When the comb-generator output amplifier is enabled, the amplitude of the 100 MHz signal and the 100 MHz harmonics increase. The 100 MHz signal amplitude increases to approximately $+12$ dBm.
 - If the signal amplitude does not increase, check that the comb-generator control line from the A7 Analog Interface assembly is switching correctly.
Refer to Foldout 7-1, HP 8595A RF Section Block Diagram, for the comb-generator control voltage values.
 - If the A7 control line is correct, suspect the A3A11 Step Recovery Diode or the A3A1 Comb Generator.

Refer to Foldout 6-1, RF Section Overall Block Diagram, for more information.

CONF TEST FAIL (H)

Description

The confidence test routine has failed.

Troubleshooting Hints

The confidence test routine identifies the analyzer function that failed the test. Refer to the **CONF TEST** description in Chapter 10 for more information.

FAIL: XXXX XXXXXXXXXXXX (H)

Description

A circuit-test failure was detected by the central processing unit (CPU) during power-up or instrument preset. A failure code has two major parts: a 4-digit code followed by a 10-digit code. The 10-digit code contains three separate failure codes. Each failure code must be converted from hexadecimal to binary before it can be interpreted, using Table 11-3 through Table 11-6.

Component-level information is provided with this error message description. Refer to the *HP 8590 Series Component-Level Information* binder for further information about the indicated components.

The Four-Digit Failure Code

The four-digit failure code identifies the circuit location of the failure on the A16 Processor/Video assembly. Component-level failure information is also provided. Each digit of the four-digit hexadecimal segment must be translated to its binary equivalent before using Table 11-3 to locate the probable failure.

The 16 LEDs along the right-hand side of the A16 assembly provide the same error information that is contained in the 4-digit failure code. Use Table 11-3 to interpret the illuminated LEDs for an instrument failure.

Here is an example of a failure code. It is unlikely that an analyzer would have so severe a failure involving all the components indicated. The example is for demonstration only.

FAIL: DF30 0625C1F72D

The four-digit failure code (DF30) is interpreted in Table 11-3. The three fail codes within the 10-digit section (0625C1F72D) are interpreted in the "The 10-Digit Failure Code" description.

Table 11-3. Four-Digit Failure Code Interpretation

Digits From Example	Equivalent Binary Value	A16 LEDs	A16 Circuit Tested	A16 Reference Designator
D →	8	15	Video RAM *	U305, U306
↵	4	14	I/O Bus Address *	U18
↵	2	13	CPU	U12
↵	1	12 †	68230	U57
F →	8	11	I/O Bus (Odd byte)	U2
↵	4	10	I/O Bus (Even byte)	U3
↵	2	9	User RAM	U5
↵	1	8	User RAM	U22
	8	7	User RAM	U5
	4	6	User RAM	U22
3 →	2	5	Calibration RAM (Odd byte)	U4
↵	1	4	Calibration RAM (Even byte)	U21
	8	3	ROM (Odd B LSB)	U6
	4	2	ROM (Even B LSB)	U23
	2	1	ROM (Odd A LSB)	U7
0	1	0	ROM (Even A LSB)	U24
<p>* Refer to the 10-digit failure code description for more information. † LED DS12 remains on after pressing PRESET.</p>				

The 10-Digit Failure Code

The 10-digit segment provides further failure information for the I/O address bus, the I/O data bus, and the A16 video RAM circuitry. Each digit of the 10-digit hexadecimal segment must be translated to its binary equivalent to obtain the failure information.

The 10-digit failure code section is divided into three separate codes. The 10-digit failure code example (0625C1F72D) is separated into three codes as shown below:

FAIL: DF30 (06) (25C1) (F72D)

Each failure code from the example is converted from hexadecimal to binary and interpreted in Table 11-4, Table 11-5, and Table 11-6.

The I/O Address Bus Failure Code. The first two digits of the 10-digit code identify the failed address lines on the I/O address bus. Convert the two digits to binary and interpret them with Table 11-4.

Table 11-4. I/O Bus Address Failure-Code Interpretation

Digits From Example	Equivalent Binary Value	A16 Circuit Tested	A16 Reference Designator
0	8	Not Used	U18
	4	Not Used	
	2	Not Used	
	1	Error at ADR 4	
6 → ↵	8	Error at ADR 3	U18
	4	Error at ADR 2	U18
	2	Error at ADR 1	U18
	1	Error at ADR 0	U18

The I/O Data-Bus Failure Code. The next four digits identify failed data lines on the I/O data bus. Convert the four digits to binary and interpret them with Table 11-5.

Table 11-5. I/O Data Bus Failure Code Interpretation

Digits From Example	Equivalent Binary Value	A16 Circuit Tested	A16 Reference Designator
2 →	8	Error at IOB 15	U3
	4	Error at IOB 14	U3
	2	Error at IOB 13	U3
	1	Error at IOB 12	U3
5 → ↵	8	Error at IOB 11	U3
	4	Error at IOB 10	U3
	2	Error at IOB 9	U3
	1	Error at IOB 8	U3
C → ↵	8	Error at IOB 7	U2
	4	Error at IOB 6	U2
	2	Error at IOB 5	U2
	1	Error at IOB 4	U2
1 →	8	Error at IOB 3	U2
	4	Error at IOB 2	U2
	2	Error at IOB 1	U2
	1	Error at IOB 0	U2

The Video RAM Failure Code. The last four digits identify the failure address for the video RAM on the A16 assembly. A video RAM failure code indicates an internal failure on the A16 assembly; the section of the Video RAM circuitry that is tested is not connected to other instrument assemblies. Convert the four digits to binary and interpret them with Table 11-6.

Table 11-6. A16 Video Ram Address Failure Code Interpretation

Digits From Example	Equivalent Binary Value	A16 Circuit Tested	A16 Reference Designator
F →	8	Error at MAD 15 *	U306
↪	4	Error at MAD 14	U305
↪	2	Error at MAD 13	U306
↪	1	Error at MAD 12	U305
7 →	8	Error at MAD 11	U306
↪	4	Error at MAD 10	U305
↪	2	Error at MAD 9	U306
↪	1	Error at MAD 8	U305
2 →	8	Error at MAD 7	U306
↪	4	Error at MAD 6	U305
↪	2	Error at MAD 5	U306
↪	1	Error at MAD 4	U305
D →	8	Error at MAD 3	U306
↪	4	Error at MAD 2	U305
↪	2	Error at MAD 1	U306
↪	1	Error at MAD 0	U305
<p>* The acronym <i>MAD</i> stands for "Multiplexed Address and Data." There are no separate address and data lines within the A16 video RAM circuitry.</p>			

Related Assemblies

A7 Analog Interface, A16 Processor/Video, A17 Memory Card, A25 Counter Lock, assemblies installed in the card cage

Troubleshooting Hints

Refer to Foldout 6-1, RF Section Overall Block Diagram, and Foldout 6-2, IF/Control Overall Block Diagram, in Chapter 6 for an overview of the assemblies attached to the I/O bus. Refer also to "A15 Motherboard Assembly" in Chapter 8 for the location of specific I/O signal traces on related assemblies.

- If a failure code for an I/O bus address or data line occurs, remove the related assemblies one at a time until the failure message disappears. Be sure to turn the analyzer power off while removing and installing each assembly.
 - If the failure message disappears, suspect the assembly that was removed last.
 - If the failure message remains after all related assemblies have been removed, suspect the A16 assembly.
- If a A16 video RAM fail code occurs, the A16 assembly is defective.

FREQ UNCAL (U) (H)

Description

The YTO (YIG-tuned oscillator) frequency is more than 20 MHz from the desired frequency.

Related Assemblies

A3A7 YTO, A7 Analog Interface, A25 Counter Lock

Troubleshooting Hints

- This error message may occur when using correction data from **DEFAULT CAL DATA**. Refer to the **DEFAULT CAL DATA** description in Chapter 10 for more information.

If **DEFAULT CAL DATA** is in use, the instrument self-calibration routines must be run. Refer to the *HP 8594A/8595A Installation and Verification Manual*.

- The error message may occur if incomplete frequency calibration factors are used. Interrupting the **CAL FREQ** self-calibration routine produces incomplete frequency calibration data.

Performing the **CAL FREQ** routine may eliminate the problem. Be sure to press **CAL STORE** to store the correction factors produced by **CAL FREQ**.

- The error message may occur if either the reference oscillator or the sampling oscillator on the A25 assembly is unlocked.

Refer to "Locating an RF/LO/IF or Video Problem" in Chapter 6 for further information.

Note

It is normal for the FREQ UNCAL message to appear briefly during the **CAL FREQ** routine.



INVALID FLATNESS DATA (U)

Description

The message is displayed when **EDIT FLATNESS** is used to edit the flatness correction constants and no start, stop, or step size has been set for the entry of the flatness data. All correction constants are probably missing.

Troubleshooting Hints

The error message appears when a new A16 Processor/Video assembly is installed or the data stored in RAM is lost. A dead BT101 battery can also produce this error message.

Follow the procedure in Chapter 9 "Spectrum Analyzer Recovery after a A16 Memory Loss" to initialize the flatness parameters.

Refer to the Frequency Response adjustment procedure in Chapter 2 for further information about entering flatness correction constants.

MIXER BIAS CAL FAILED

Description

During the **CAL MXR** routine, the comb signal was not found at the displayed center frequency.

Related Assemblies

A3A1 Comb Generator, A3A11 Step Recovery Diode, A3A12 3dB Attenuator, J2 Connector

Troubleshooting Hints

- Make sure that the 100 MHz COMB OUT is connected to the analyzer input using the Comb Generator cable (SMA to Type N) supplied with the analyzer.
- Perform the following steps to verify the comb-generator output manually:
 1. Press the following keys:
 - PRESET**
 - FREQUENCY** 100 **MHz**
 - SPAN** 500 **MHz**
 2. Look for the 100 MHz comb-generator signal to the right of the local oscillator signal. When **COMB GEN ON OFF** is OFF, this signal has an amplitude of approximately -8 dBm and the 100 MHz harmonics are less than -20 dBc.
 3. Press the following keys:
 - AUX CTRL**
 - COMB GEN ON OFF** (On)
 4. When the comb-generator output amplifier is enabled, the amplitude of the 100 MHz signal and the 100 MHz harmonics increase. The 100 MHz signal amplitude increases to approximately +12 dBm.
 - If the signal amplitude does not increase, check that the comb-generator control line from the A7 Analog Interface assembly is switching correctly.

Refer to Foldout 7-1, HP 8595 A RF Section Block Diagram, for the comb-generator control voltage values.
 - If the A7 control line is correct, suspect the A3A11 Step Recovery Diode or the A3A1 Comb Generator.

Refer to Foldout 6-1, RF Section Overall Block Diagram, for more information.

OVEN COLD (M)

Description

This message is displayed for instruments equipped with Option 004, Precision Frequency Reference.

The message is displayed for 5 minutes after the instrument is turned on. The message alerts the user that the oven in the A22 Precision Frequency Reference has not been on long enough to warm the reference to its operating temperature.

Note

On earlier analyzers, the OVEN COLD message is displayed briefly during instrument preset.



Related Assemblies

A22 Precision Frequency Reference (Option 004)

Troubleshooting Hints

This is a timed message that comes on whenever the instrument is turned on; the temperature of the A22 Precision Frequency Reference oven-controlled crystal oscillator (OCXO) is not measured.

The instrument firmware displays the message only when it senses that the A22 assembly is connected to its power supply through W15, the OCXO power cable. If the message does not appear, check the W15 cable.

POS-PK FAIL (H)

Description

The positive-peak-detector check has failed during the confidence test routine, **CONF TEST**. The level of the noise floor for the positive-peak detector is statistically compared to that of the sample detector. The mean of the data from the positive-peak detector should be greater than the mean of the data from the sample detector.

Related Assemblies

A16 Processor/Video

Troubleshooting Hints

This test performs a functional check of switching for the positive-peak detector on the A16 Processor/Video assembly.

Refer to the **CONF TEST** description in Chapter 10 for more information about the confidence test routine.

RES-BW SHAPE FAIL (H)

Description

During the confidence test routine, **CONF TEST**, the 3 dB bandwidth of a resolution bandwidth was not within 20% of its nominal value. The 10 kHz, 30 kHz, 100 kHz, 300 kHz, 1 MHz, and 3 MHz bandwidths are checked and the bandwidths that fail are displayed.

Note



On earlier analyzers, resolution bandwidth accuracy is an instrument characteristic, not a specification.

Related Assemblies

A7 Analog Interface, A11 Bandwidth Filter, A13 Bandwidth Filter

Troubleshooting Hints

- The bandwidth of the failed resolution bandwidths may have drifted since the last time the self-calibration routines were run. The **CAL AMPTD** self-calibration routine corrects for bandwidth error.
If a bandwidth drifts out of tolerance soon after performing **CAL AMPTD**, a bandwidth-filter assembly or bandwidth control line may be unstable.
 1. Check the 3 dB bandwidth of the failed resolution bandwidths using the **3 dB POINTS** softkey.
 2. Use **DISPLAY CAL DATA** to view the current bandwidth control factors.
 3. Perform the **CAL AMPTD** self-calibration routine. Use **DISPLAY CAL DATA** to monitor changes in the bandwidth control factors each time the **CAL AMPTD** routine is performed.
 4. Repeat the **CONF TEST** routine. If the error message is still present, look for an unstable bandwidth-filter assembly or bandwidth control line.

Refer to "Bandwidth Control Lines for the A11 and A13 Bandwidth Filter Assemblies" in Chapter 8 when troubleshooting the bandwidth control lines.

- The bandpass shape of the failed resolution bandwidths may have drifted since the last time the self-calibration routines were run.
 1. Look at the bandpass shape of each failed bandwidth. If realignment is needed, refer to the Crystal and LC Bandwidth Filter adjustment procedure in Chapter 2.
 2. Run the **CAL AMPTD** self-calibration routine and store the data using **CAL STORE**.
 3. Repeat the **CONF TEST** routine. If the error message is still present, one of the bandwidth-filter assemblies may be defective.

Refer to the **CONF TEST** description in Chapter 10 for more information about the confidence test routine.

RES-BW NOISE FAIL (H)

Description

During the confidence test routine, **CONF TEST**, the noise floor level was too high for the indicated resolution bandwidth.

Starting with the widest resolution bandwidth, the test compares the noise floor amplitude of each bandwidth to the noise floor amplitude of the next, narrower resolution bandwidth. If a decrease in noise-floor amplitude does not occur, the test displays the narrower bandwidth as a test failure.

Related Assemblies

A11 Bandwidth Filter, A13 Bandwidth Filter

Troubleshooting Hints

Refer to the **CONF TEST** description in Chapter 10 for more information about the confidence test routine.

- A high noise floor can be caused by a defective bandwidth control line.

Look for a change in noise floor level and bandwidth when manually switching between bandwidths. If no change occurs, check the bandwidth control lines from the A7 Analog Interface assembly.

Refer to Foldout 6-2, IF/Control Overall Block Diagram, in Chapter 6 and "Bandwidth Control Lines for the A11 and A13 Bandwidth Filter Assemblies" in Chapter 8 for further information.

- A high noise floor can also be caused by loose screws in the IF assembly section. Make sure the IF assembly cover screws are properly tightened.

REF UNLOCK (M)(H)

Description

The oscillator on the A9 Third Converter is not locked to a 10 MHz frequency reference. The analyzer must be connected to one of the following frequency references:

- 10 MHz standard timebase. The reference is a room-temperature crystal oscillator (RTXO) that is located on the A25 assembly.
- Option 004, Precision Frequency Reference. The reference is a oven-controlled crystal oscillator (OCXO).
- External 10 MHz frequency reference.

Related Assemblies

A22 Precision Frequency Reference (Option 004), A25 Counter-Lock

Troubleshooting Hints

Refer to Foldout 6-1, RF Section Overall Block Diagram, for an overview of the RF and LO section operation.

1. Check the rear-panel cable connections for the 10 MHz reference.

When using either the standard 10 MHz timebase or the precision frequency reference, make sure that the 10 MHz REF OUT on the rear panel is connected to the EXT REF IN. The W6 jumper is supplied with the analyzer for this purpose.

When using an external 10 MHz reference, make sure it is connected to the EXT REF IN on the rear panel.

2. If the rear panel connection is correct, check the power output of the 10 MHz frequency reference.
 - The standard 10 MHz timebase (RTXO) that is located on the A25 assembly has an typical output of 0 dBm \pm 6 dB.
 - Option 004, A22 Precision Frequency Reference (OCXO), has an typical output of 0 dBm \pm 3 dB.
 - An external 10 MHz reference should have an output between -2 dBm and +10 dBm.
3. If the output of the 10 MHz reference is correct, check the continuity of W18, the EXT REF IN cable, and W16, the 10 MHz OUT cable. (W17 replaces W16 when Option 004 is installed.)
4. Check the continuity of the VTO_TUNE control line. Refer to "LO Section" in Chapter 7 and "A15 Motherboard Assembly" in Chapter 8 for information about VTO_TUNE.
5. Check the continuity of the W14 ribbon cable and the W21 coaxial cable.
6. Check the continuity of the A25 assembly connections to the A9 assembly that pass through the A15 Motherboard. Refer to "LO Section" in Chapter 7 and "A15 Motherboard Assembly" in Chapter 8 for information about the A25 assembly.
7. If the error message is still present, suspect the A25 Counter-Lock assembly.

SAMPLE FAIL (H)

Description

During the confidence test routine, **CONF TEST**, the sample-detector test has failed. The test makes a statistical comparison between the peak-to-peak amplitude of the noise floor for the positive-peak detector and the noise floor for the sample detector.

The error message is displayed if the standard deviation of the data for the sample detector is less than the standard deviation of data for the positive-peak detector.

Related Assemblies

A16 Processor/Video

Troubleshooting Hints

This test performs a functional check of switching for the sample detector on the A16 Processor/Video assembly.

Refer to the **CONF TEST** description in Chapter 10 for more information about the confidence test routine.

STEP GAIN/ATTEN FAIL (H)

Description

During the confidence test routine, **CONF TEST**, the step-gain switching check has failed. Looking at displayed noise, the test steps the reference level from -60 dBm to +30 dBm, in 10 dB increments, with the input attenuator set to 60 dB. The error message is displayed if the noise level does not increase for each 10 dB step in reference level.

Related Assemblies

A12 Amplitude Control

Troubleshooting Hints

The confidence test performs a functional check of the A12 assembly step gains; it does not check the function of the A12 step attenuators. The test passes if it detects any increase in noise floor level for each 10 dB change in reference level.

Refer to "IF Section Gain Control" in Chapter 8 for further information about the operation of the 10 dB step gains.

Note



There is no manual adjustment for the 10 dB step gains. The **CAL-AMPTD** self-calibration routine corrects for the 10 dB step gains and input attenuator errors. Refer to the **CAL-AMPTD** description in Chapter 10 for more information.

If one of the 10 dB step gains appears to be faulty, check the step-gain control lines from the A7 Analog Interface assembly.

Refer to "A15 Motherboard Assembly" in Chapter 8 for the location of the step gain control lines.

If the control lines function correctly, suspect a A12 Amplitude Control assembly failure.

Refer to the **CONF TEST** description in Chapter 10 for more information about the confidence test routine.

SRQ . . . (M)

Description

The service request is active. Service requests are an informational message and are explained in Appendix B of the *HP 8594A/8595A Installation and Verification Manual*.

VID-BW FAIL (H)

Description

During the **CONF TEST** routine the video bandwidth check has failed. The test checks for a decrease in the peak-to-peak excursion of the noise trace as the video bandwidth is decreased.

Related Assemblies

A14 Log Amplifier/Detector, A16 Processor/Video

Troubleshooting Hints

The **CONF TEST** routine performs a functional check of switching for the video bandwidth circuitry on the A16 Processor/Video assembly.

Refer to **CONF TEST** description in Chapter 10 for more information about the confidence test routine.

Problems with the low-pass filter on the A14 Log Amplifier/Detector assembly can cause the video bandwidths to appear to be incorrect.

Component-Level Information Packets

Component-level information is available for selected instrument assemblies. The information for each repairable assembly is provided in the form of Component-Level Information Packets (CLIPs).

A CLIP packet consists of a parts list, component-location diagram, and schematic diagram relating to a unique instrument assembly. An HP part number is assigned to each CLIP packet. When an instrument assembly part number changes, a new CLIP is generated.

Ordering CLIPs

For ordering convenience, current CLIPs for a specific instrument are combined into Component-Level Information binders. The current set of CLIPs contains information supporting the instrument assemblies manufactured at the time this manual was printed, plus a packet containing general CLIP information.

A complete set of CLIPs can be obtained by ordering the *HP 8590 Series Spectrum Analyzers Component-Level Information* binder, HP part number 5958-7046.

Updated or replacement CLIPs may be ordered through your local Hewlett-Packard Sales or Service office using the CLIP part number provided in Table A-1. To order *General CLIP Information*, use HP part number 5958-7060.

CLIPs are packaged in protective plastic envelopes. To use and store your CLIPs effectively, the following accessories are available:

- 2-1/2 inch CLIP binder (for 25 to 30 packets) HP part number 9282-1134
- 2 inch CLIP binder (for 15 to 25 packets) HP part number 9282-1133
- 1-1/2 inch CLIP binder (for fewer than 15 packets) ... HP part number 9282-1132
- Replacement plastic CLIP envelope HP part number 9222-1536

Note

CLIPs may not be available for recently introduced assemblies.



**Table A-1.
HP 8595A Spectrum Analyzer
Board Assembly, Serial Number, and CLIP Part Number Cross-Reference**

Assembly	Instrument Serial Prefix	Board Assembly Part Number	CLIP Part Number
A1A1 Keyboard	3051A and above	08590-60004*	08590-90116
A3A1 Comb Generator	3051A and above	08569-60024*	08569-90132
A7 Analog Interface	3051A and above	08595-60001*	08595-90003
A9 Third Converter	3051A and above	8590-60192*	08590-90146
A9 Third Converter (Option 009 and 010)		08593-60021*	
A10 Tracking Generator Control (Option 009 and 010)	3051A and above	5062-6432*	5960-2501
A10 Tracking Generator Control (Option 009 only)		5062-8219*	
A11/A13 Bandwidth Filter Boards #1 and #2	3051A and above	5062-8236	5062-8260
A12 Amplitude Control	3051A and above	08590-60105*	08590-90121
A14 Log Amp	3051A and above	08590-60149*	08590-90122
A15 Motherboard	3051A and above	08591-60017*	08591-90014
*These CLIPs are included in the current Component-Level Information binder.			

Table A-1.
HP 8595A Spectrum Analyzer
Board Assembly, Serial Number, and CLIP Part Number Cross-Reference
(continued)

Assembly	Instrument Serial Prefix	Board Assembly Part Number	CLIP Part Number
A16 Processor/Video	3051A and above	08593-60005*	5960-2581
A17 Memory Card Reader (Option 009)	3051A and above	08590-60107*	08590-90124
A20 HP-IB I/O (Option 021)	3051A and above	08590-60108*	08590-90125
A21 RS-232 I/O (Option 029)	3051A and above	08590-60109*	08590-90126
A25 Counter Lock	3051A and above	08591-60027*	08591-90028
A101 Fast ADC (Option 101 and 301)	3051A and above	5062-7079	5958-7174
A102 AM/FM Speaker and TV Synch Trigger (Option 102 and 301)	3051A and above	5062-1982*	5958-7055
A103 Demodulator/ Quasi Peak Detector (Option 109)	3051A and above	5062-1983*	5960-2504
A105 Gate Card (Option 105)	3051A and above	5062-7754*	5960-2568
*These CLIPs are included in the current Component-Level Information binder.			

S E R V I C E N O T E

SUPERSEDES: None

HP 8595A Spectrum Analyzer

Serial Numbers: 0000A00000 / 9999A99999

Analyzer appears to reset when Edit Flatness is initiated.

Situation:

When flatness correction data is to be modified or re-entered, the analyzer is Preset and the service code is entered. The data is then modified or new data entered by selecting "Edit Flatness". Instead of allowing entry of the data, the analyzer "Resets". The result is that the data can not be modified or new data entered.

Solution/Action

1. Press Preset and enter the service code (Frequency -2001Hz). Select the "IDNUM" command under "Flatness Data". Select "3" to identify the analyzer as an 8593A and then Init Flat 22 GHz.
2. Repeat the steps in 1. but select "5" to identify the analyzer as an 8595A and then press Init Flat. The flatness parameters will initialize and then Preset the instrument. Now, using the service code, you can proceed to modify or enter data into the analyzer.

DATE: 10 December 1991

ADMINISTRATIVE INFORMATION

SERVICE NOTE CLASSIFICATION:		
INFORMATION ONLY		
AUTHOR:	ENTITY:	ADDITIONAL INFORMATION:
PGS	5300	