



OPERATION/MAINTENANCE INSTRUCTIONS FOR DLM-50-20-100

SPECIFICATIONS

115 VAC \pm 10% 47-63 Hz or 230 VAC \pm 10% 47-63 HZ*			
Input Voltage: 3-50 VDC	Meter Accuracy:		\pm 3%
Max. Current: 20A	Program Voltage:		0-6V
Max. Power: 100W	Current Sample:		20mV/A

OPERATING INSTRUCTIONS

External Connections:

*Check AC input voltage range. For 115V install W1 and W2, W3 not used; for 230 VAC install W3, W1 and W2 not used.

Connect AC input voltage to TB2-1 (AC), TB2-2 (ACC), TB2-3 (GND). If remote program is to be used, connect + to TB2-4 and RTN to TB2-5. If current sample is to be used, connect + to TB2-6 and RTN to TB2-5. Connect source under test to TB1-1 (+) and TB1-2 (-).

OPERATION

Place ammeter in correct range. Select mode.

C/C- Constant current. Load will draw from 0-full current as adjusted with the coarse and fine load adjust controls. The load current will remain fixed regardless of any change in input source voltage.

NOTE: Power supplies and similar devices incorporating a fold-back current limit circuit may not build up into a constant current load.

A/V- Amps per volt. Simulates a resistor; load current will increase as source voltage increases. Minimum resistance (load adjust fully clockwise) will provide 5A of load current for each source volt.

RMT- Remote program. The front panel load adjust controls vary the gain of the remote program signal controlling the load current. With the coarse load adjust control fully clockwise, load current may be varied from 0 to full load as the RMT program signal is varied from 0-6 VDC. Load will be constant current: see note under C/C. For dynamic load testing any positive 0-6V signal may be applied.

CALIBRATION

Ammeter- Use and external reference ammeter. Adjust load for mid-scale ammeter indication; adjust R29 for low range, or R27 for high range, until front panel ammeter agrees with reference ammeter.

Current Sample—Set load for 20A in C/C mode. Adjust R39 for a current sample signal of 400mV.

A/V- A/V Mode, set coarse adjust fully clockwise. Apply a source voltage of 4V and adjust R21 for 20A of load current.

RMT PGM- Load connected to 5V source, coarse loads adjust fully clockwise. Apply a remote program signal of 6.0 VDC. Adjust R9 for 20A of load current. Reduce program signal to 0.5V and adjust R5 for 1.67A of load current. Recheck with 6.0V program signal.

Current Limit- Load connected to 5V source, A/V mode, increase the load current to between 21 and 25A. Adjust R23 so the maximum current the load will draw is 23A.

Power Limit- Load in constant current set for 3A with 5V source. Increase source voltage to 50V; adjust R18 until load current is limited 2.5A.

A bias of +8.2V and -3.3V is developed by zener diodes VR1, VR2 and series dropping resistor R2 from the =25 VDC across C1. Load current is controlled by operational amplifier U1a which compares a reference voltage that is selected from VR3 by the load adjusts controls R11 and R12 to the voltage developed across the current sample resistors R35-R38.

As the reference voltage is increase, the non-inverting input of U1a becomes more positive than the inverting input. This causes U1a output to go positive which drives transistors Q1 thru Q6, causing more current to flow thru the load. When sufficient current flows through current sense resistors R35-R38 to develop a feedback voltage at U1a inverting input equal to the reference at the non-inverting input, the current is regulated at that level.

In the remote program mode, the reference voltage diode VR3 is replaced by the external programming signal.

In the A/V mode, the reference voltage is developed from the source voltage at the load input terminals. As the source voltage increases, the reference voltage will also increase causing more current to flow through the load, simulating a resistor.

Current/Power Limit- The voltage developed across the current sensing resistors R35-R38 is fed through R23 (current limit adjust) to U1b inverting input. R16 keeps the inverting input normally low. When sufficient current flows through the current sense resistors, U1b inverting input becomes positive with respect to the non-inverting input. This causes U1b output to limit the drive to shunt transistors by restricting the base drive of Q1 via CR1, thus limiting the current through the load.

As the source voltage is increased, VR6 conducts which allows current to flow through R17, R18, and R20. This signal is added to the current limit signal which causes the current limit point to be reduced as the source voltage is increased, creating a power limiting circuit.

To prevent excessive reduction in current at higher voltages, zener diode VR4, R19 and VR5 are used to shunt away some of the signal which is added to the current limit signal. This creates two "knees" on the power limit curve for better accuracy.



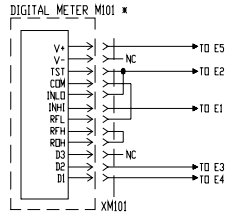

INPUT:
103-126 VAC
47-63 Hz

PCB ASSY I12069-07

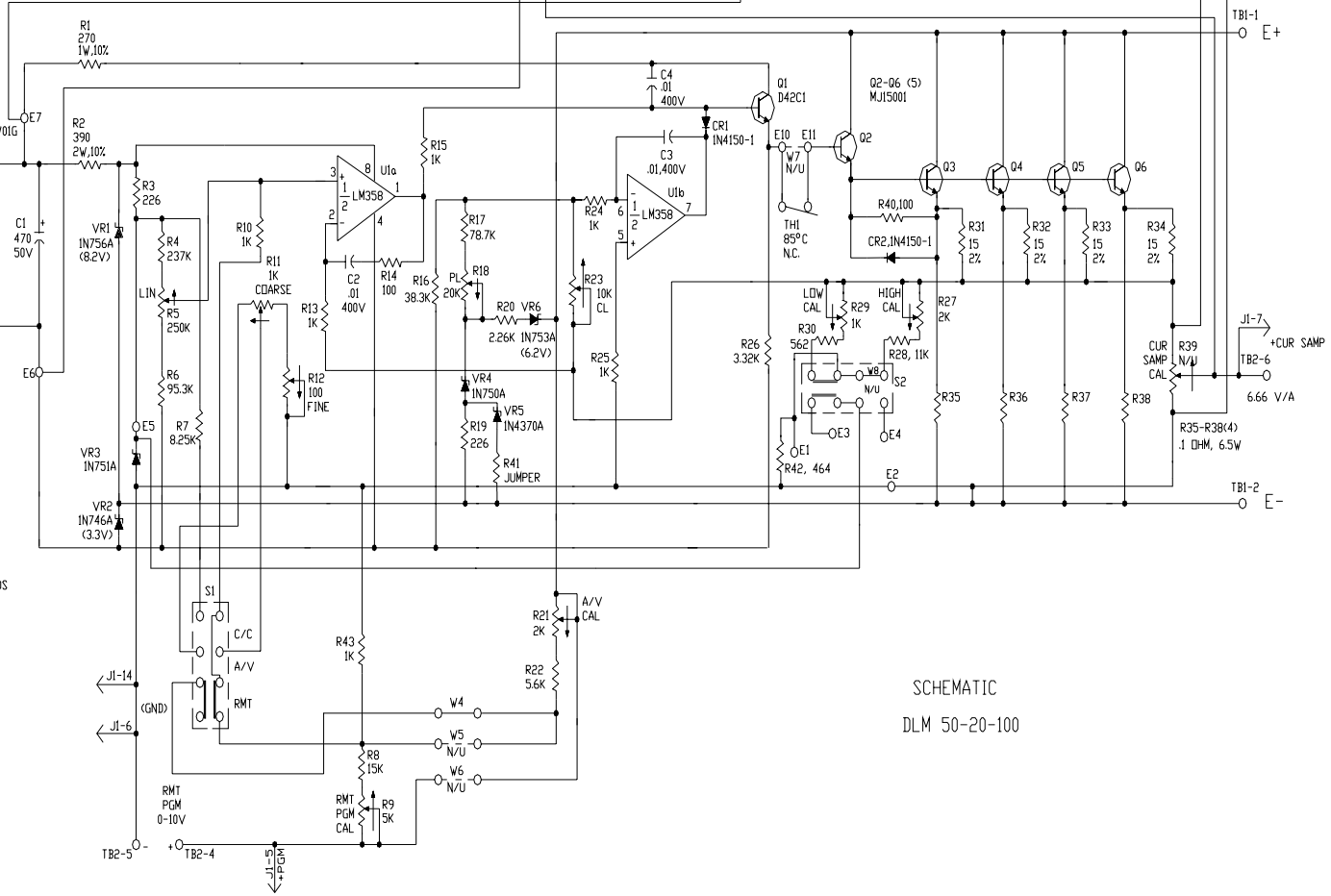
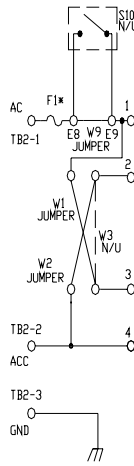
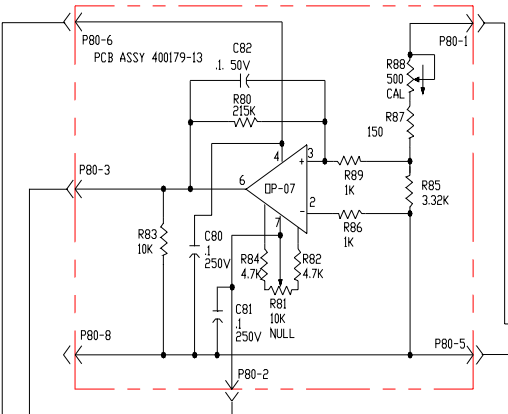

NOTES:
1. UNLESS OTHERWISE SPECIFIED:
-ALL RESISTOR VALUES ARE OHMS,
1/4W,1%
-ALL CAPACITOR VALUES ARE MICROFARADS

SCHEMATIC
DLM 50-20-100