

Provided by:



www.atecorp.com
(800) 404-ATEC

QSA GLOBAL.



OPENVISION DX.

Inspect large amounts of piping in environments such as refineries and petrochemical plants onshore and offshore in a fraction of the time.



For more information visit us at qsa-global.com

WHY OPENVISION.

RUGGED AND RELIABLE. A rugged aluminum and carbon fiber c-arm house a robust x-ray source, controller, battery, and a CMOS imager. Battery life is 3+ hours of operation and data is securely stored on the internal hard drive or remote tablet.

MINIMIZE MISSED CALLS. High resolution live digital video allows operators to minimize missed calls. Direct download of high-resolution images and videos provide quick transfer into reports for rapid reporting.

ACCESS TIGHT SPACES. A 30% thinner imager and a repositionable c-arm increases access to tight spaces.

MAXIMIZE PROBABILITY OF DETECTION. New ergonomic features support multiple configurations to facilitate both vertical and horizontal inspections at various heights, enable access to tighter spaces, and lessen operator fatigue.

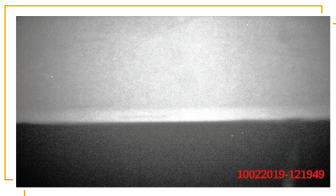

Scale

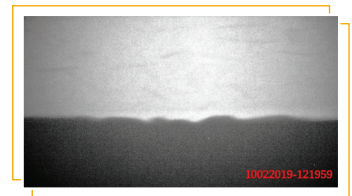

Pitting



Corrosion

Weld

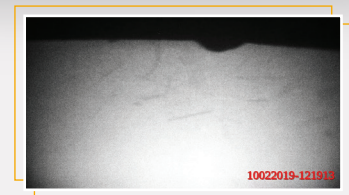
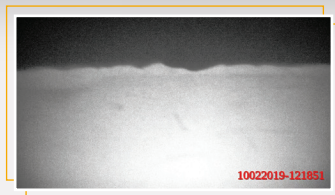

OpenVision is a true nondestructive testing (NDT) method that uses live video output for real-time radiographic inspection of hundreds of feet (many tens of meters) of insulated piping for indications of corrosion.



CAPTURE DEFECTS

A patent-pending combination of a c-arm, mounted 70 kV x-ray source, and digital imager allows you to observe external defects as small as 0.010-inch (250 micron) on insulated piping. Record high-resolution still images and video directly onto OpenVision DX's internal storage or remotely from the wireless monitor. Review images and videos in real time or download for integration into client reports.

ACCESSORIES.



RUGGED TABLET

Wireless monitor allows viewing of live video feed from OpenVision.



PIRATE EYE

Hands-free viewing of live video feed from OpenVision.

SPECIFICATIONS

WEIGHT

C-Arm	15 lb (6.8 kg)
Monitor + Handle	2 lb (0.9 kg)
Shipping Weight	50 lb (23 kg)

STARTUP/SHUTDOWN

Startup	~30 sec
Shutdown	~5 sec

TEMPERATURE

Operating	-20 to 120 °F (-29 to 49 °C)
Storage	-20 to 140 °F (-29 to 60 °C)

X-RAY OUTPUT AT 12 in (30.5 cm)

	Voltage kV	Current mA	Output R/hr (Sv/hr)
Low	40	0.300	50 (0.5)
Medium	55	0.218	80 (0.8)
High	70	0.171	95 (0.95)

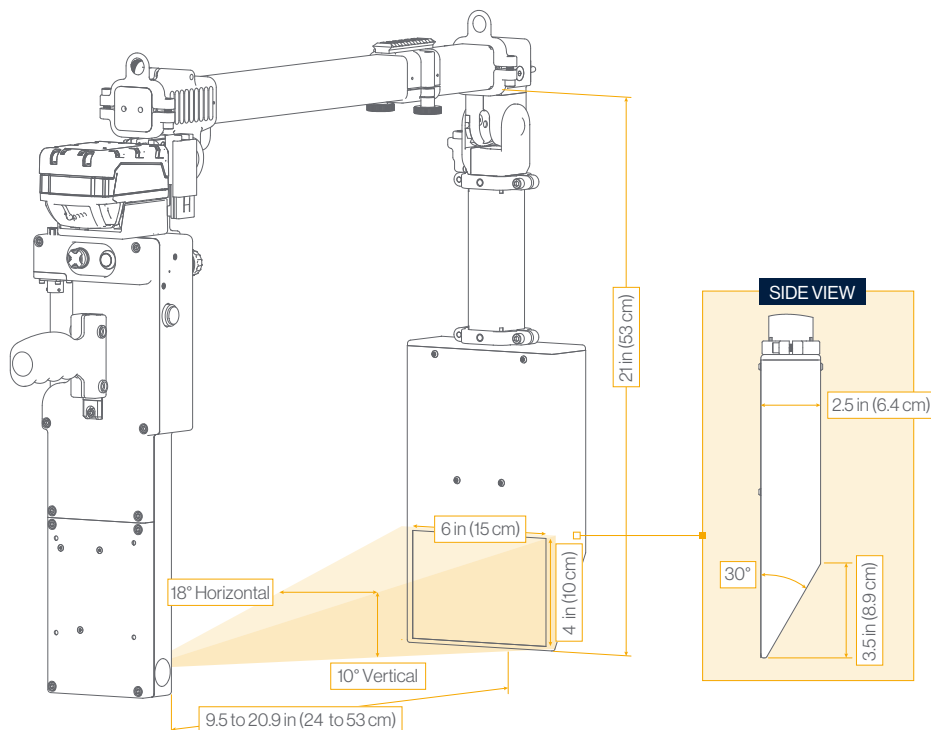

IMAGE RESOLUTION

Anomalies down to 250 μm/ 0.01 in

BATTERY LIFE (5 Ah Battery)

3 Hours Continuous Duty Cycle
8 Hours Standby

DISPLAY OPTIONS

HDMI Monitor: 7 in (17.5 cm) LED; 1920 × 1200
WiFi Tablet: 10 in (25.4 cm); 1400 × 900; 2.4 GHz
PirateEye: HUD; 854 × 480

RECORDING CAPABILITIES

Internal: 128 GB
WiFi Tablet: 128 GB
Resolution: 1280 × 720
File Transfer: USB

STANDARDS

ANSI/HPS N43.5 (2005)
ISTA 3A Over the Road Vibration Standard
MIL-STD-810, Method 514, Annex C, Cat 4
REACH/ROHS
FDA Accession #: 1680071-000



For more information
visit us at
qsa-global.com