

## AES 5501 AUTOMOTIVE EMISSIONS SYSTEM FOR ISO 7637-2



- **The only complete, compliant solution for ISO 7637-2 emissions testing**
- **Clean, reliable 100 A operation with very low voltage drop**
- **Industry standard relay footprint for a wide selection of relays (one 100 A relay included)**
- **Separate control station with automatic, manual or external triggering of the switching behavior**
- **Smaller switch enclosure for easier compliance to various cable-length requirements**
- **Totally redesigned AN with improved, fully compliant impedance curve**
- **Convenient measurement ports**

The AES 5501 is a system of electronic and mechanical switches, an artificial network, and a unique control station designed for emissions testing to ISO 7637-2. Having gone through meticulous development and intensive beta testing, the AES 5501 contains unique features and uncompromising quality and conformity found nowhere else. Consisting of a four-part solution, the user has complete control over where, when and how the switches can be placed and controlled, including the necessary drive voltages for the relays.

The 100 A connectors are carefully placed and countersunk to allow precise cabling between the switches, the artificial network and test bench and allows for the electronic or mechanic switches to be placed at any point before or after the artificial network. Multiple switches may also be utilized at the same time as required. This careful attention to detail for switch placement and cable length means that numerous manufacturer standards can also be met. The AES 5501 features a rugged construction with unpainted underside for good earth contact, precise switching control and numerous monitoring locations. A counter for the relay and LED indicators for both electronic and mechanical switches are provided. The AES 5501 has temperature controlled fans for quiet operation and a thermal shutdown feature.

### Block diagram

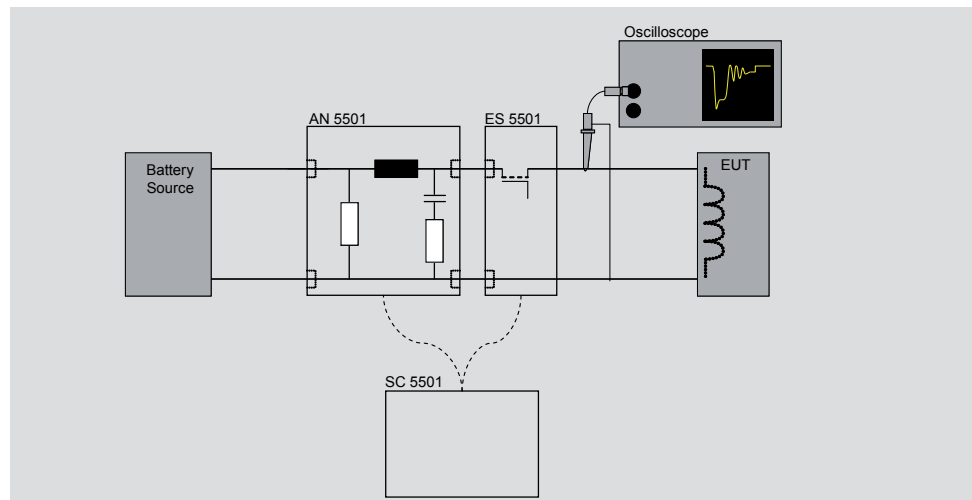

# AES 5501 AUTOMOTIVE EMISSIONS SYSTEM FOR ISO 7637-2

Electronic switch - typical switching curve with test load

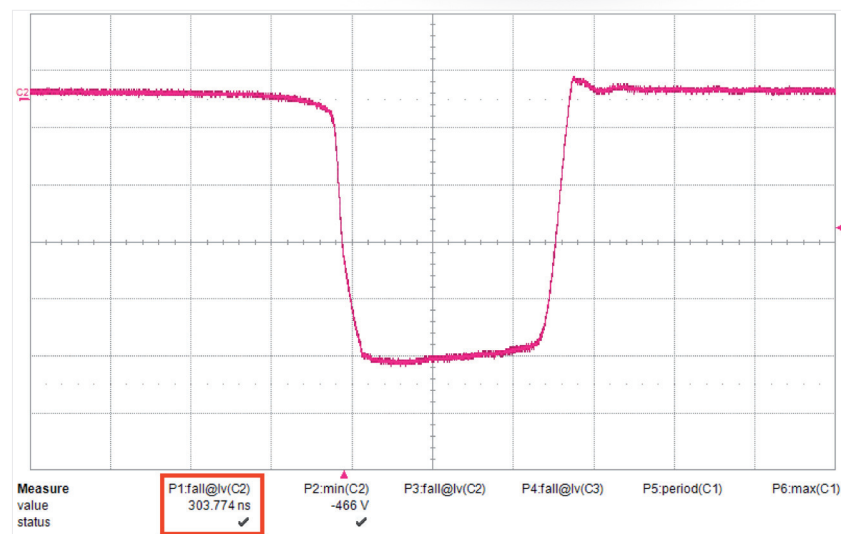

Typical impedance curve of AN 5501

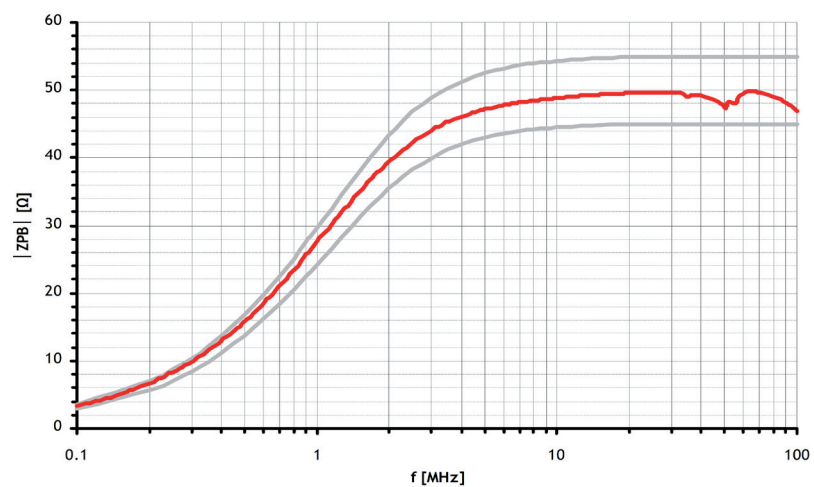

**Teseq AG**  
 Nordstrasse 11F 4542 Luterbach Switzerland  
 T +41 32 681 40 40 F +41 32 681 40 48  
 sales@teseq.com [www.teseq.com](http://www.teseq.com)

© February 2011 Teseq®  
 Specifications subject to change without notice.  
 Teseq® is an ISO-registered company. Its products  
 are designed and manufactured under the strict  
 quality and environmental requirements of the ISO  
 9001. This document has been carefully checked.  
 However, Teseq® does not assume any liability for  
 errors or inaccuracies.

# AES 5501 AUTOMOTIVE EMISSIONS SYSTEM FOR ISO 7637-2

## Technical specifications

<b>Complete system</b> <sup>1)</sup>		
Battery current	100 A	
Inrush current <sup>2)</sup>	300 A for 200 ms	
Battery voltage	0 to 60 VDC	
Shunt resistor (R <sub>s</sub> )	10, 20, 40, 120 Ω, Ext.	
Trigger modes	External, internal, manual	
Battery off time (t <sub>off</sub> )	10 ms – 10 s ±(10% + 10 ms)	
Battery on time (t <sub>on</sub> )	0.5 ms – 10.5 s ±(10% + 10 ms)	
Mains input voltage	85 – 264 VAC, 47 – 63 Hz	
Available relay voltage	12, 24, 36 V (for 42 V applications)	
<b>Electronic switch</b>		
Switching time Δt <sub>s</sub>	300 ns ±20% <sup>3)</sup>	
Voltage drop	<1 V @ 25 A Typical 2.1 V @ 100 A	
Transient voltage protection	440 V	
<b>Mechanical switch</b>		
Type	Automotive relay	
Contacts	High purity AgNi with no suppression across contacts	
Voltage rating	> 400 V	
<b>Artificial network</b>		
Inductance	5 μH	
Capacitance	0.1 μF	
Resistance	50 Ω	
Impedance	As per ISO 7637-2 (see above impedance curve)	
Connectors	100 A MC type, countersunk, 50 mm above ground plane	
Housing	Stainless steel, unpainted underside, screw terminal and earth connections	
Indicators	Counter on relay, LED indicator on controller for mechanical and electronic switches	
Measurements ports	MS 5501, ES 5501 - directly connected to output AN 5501 – 5.6 k output impedance (to output connector – necessary for improved RF performance)	
Physical dimensions (L x W x H)	ES 5501	125 x 125 x 125 mm
	MS 5501	125 x 125 x 125 mm
	AN 5501	340 x 270 x 205 mm
All tolerances ± 10% unless otherwise noted.		

**Teseq AG**  
 Nordstrasse 11F 4542 Luterbach Switzerland  
 T +41 32 681 40 40 F +41 32 681 40 48  
 sales@teseq.com [www.teseq.com](http://www.teseq.com)

© February 2011 Teseq®  
 Specifications subject to change without notice.  
 Teseq® is an ISO-registered company. Its products are designed and manufactured under the strict quality and environmental requirements of the ISO 9001. This document has been carefully checked. However, Teseq® does not assume any liability for errors or inaccuracies.

# **AES 5501**

## **AUTOMOTIVE EMISSIONS SYSTEM FOR ISO 7637-2**

- 1) Active, temperature dependant cooling. The ES 5501 is depending on duty cycle, approximately 3 minutes at 100 A with 100% duty cycle before the switch will be deactivated for cooling.
- 2) With supplied relay or electronic switch
- 3) With test load defined in ISO 7627-2. Purely resistive loads display typically in the range of a few microseconds.

### **Accessories**

Included: 4 x 60 mm cable, MC connector

Included: 2 x 100 mm cable, MC connector

Included: 4 x 0 mm pin, used when the housings will be pushed together (for zero millimeter distance)

Included: INA 5031 – 100:1 high voltage probe compliant to ISO 7637-2

Optional: INA 163 – Set of ten MC to banana adapters (only available in red)

Optional: INA 5500-TL – Reference load ( $R = 0.6 \Omega$ ,  $L = 50 \mu\text{H}$ )

Optional: INA 5500-CK – Calibration kit for impedance curve verification (used for connection to network analyzer)

Optional: MS 5501 – Additional unit for additional prepared relays

Optional: Various inserts for MC 5501 for industry standard relay footprints

**Switch housings are compact, optimized for conformity to strict layout requirements and offer ample earth contacts.**



### **Teseq AG**

Nordstrasse 11F 4542 Luterbach Switzerland  
T +41 32 681 40 40 F +41 32 681 40 48  
sales@teseq.com [www.teseq.com](http://www.teseq.com)

© February 2011 Teseq®

Specifications subject to change without notice. Teseq® is an ISO-registered company. Its products are designed and manufactured under the strict quality and environmental requirements of the ISO 9001. This document has been carefully checked. However, Teseq® does not assume any liability for errors or inaccuracies.

691-268B February 2011

# **T ESEQ**

Advanced Test Solutions for EMC