



Errata

Title & Document Type: 8165A Signal Course Operating and Service Manual

Manual Part Number: 08165-90005

Revision Date: September 1983

HP References in this Manual

This manual may contain references to HP or Hewlett-Packard. Please note that Hewlett-Packard's former test and measurement, semiconductor products and chemical analysis businesses are now part of Agilent Technologies. We have made no changes to this manual copy. The HP XXXX referred to in this document is now the Agilent XXXX. For example, model number HP8648A is now model number Agilent 8648A.

About this Manual

We've added this manual to the Agilent website in an effort to help you support your product. This manual provides the best information we could find. It may be incomplete or contain dated information, and the scan quality may not be ideal. If we find a better copy in the future, we will add it to the Agilent website.

Support for Your Product

Agilent no longer sells or supports this product. You will find any other available product information on the Agilent Test & Measurement website:

www.tm.agilent.com

Search for the model number of this product, and the resulting product page will guide you to any available information. Our service centers may be able to perform calibration if no repair parts are needed, but no other support from Agilent is available.



OPERATING AND SERVICE MANUAL

8165A PROGRAMMABLE SIGNAL SOURCE

(Including Options 002, 003 and 907 to 910)

SERIAL NUMBERS

This manual applies directly to instrument with serial number 2248G01961 and higher. Any change made in instruments having serial numbers higher than the above number will be found in a "Manual Changes" supplement supplied with this manual. Be sure to examine the supplement for changes which apply to your instrument and record these changes in the manual. Backdating information for instruments with lower serial numbers can be found in Section 7 (yellow pages).

© HEWLETT-PACKARD GmbH 1979
D-703 BÖBLINGEN, HERRENBERGER STR. 110
FEDERAL REPUBLIC OF GERMANY

MANUAL PART No. 08165-90005
MICROFICHE PART No. 08165-95005

PRINTED: SEP 1983

CONTENTS

Section	Page	Page
Section 1	General Information	
1-1	Introduction	1-1
1-6	Safety Considerations	1-1
1-9	Instruments Covered by Manual	1-1
1-11	Description	1-1
1-13	Options	1-1
1-18	Accessories Supplied	1-2
1-20	Recommended Test Equipment	1-2
Section 2	Installation	
2-1	Introduction	2-1
2-3	Initial Inspection	2-1
2-5	Preparation for Use	2-1
2-6	Power Requirements	2-1
2-10	Power Cable	2-1
2-13	HP-IB Connector	2-2
2-15	HP-IB Logic Levels	2-2
2-17	Operating Environment	2-2
2-19	Front Handle/Rack Mounting	2-3
2-21	Use of Rear Panel Connectors	2-3
2-23	Claims and Repackaging	2-3
2-24	Claims for Damage	2-3
2-26	Storage and Shipment	2-3
Section 3	Operation	
3-1	Introduction	3-1
3-3	Special Operating Conditions	3-1
3-5	Operator's Checks	3-1
3-7	Controls, Connectors and Indicators	3-1
3-9	Operating Instructions	3-1
3-12	Function and Duty Cycle	3-2
3-14	Input Modes	3-2
3-41	Output Parameters	3-5
3-45	Selection and Storage of Parameters	3-7
3-60	Error Indication	3-7
3-62	Programming Instructions	3-8
3-66	Addressing	3-8
3-68	Mode and Parameter Setting	3-9
3-70	Control Messages and Commands	3-10
3-79	Program Example	3-11

Section 4	Performance Tests	Page
4-1	Introduction	4-1
4-3	Equipment Required	4-1
4-5	Test Record	4-1
4-7	Performance Tests	4-1
4-10	Frequency	4-2
4-11	Burst	4-3
4-12	Amplitude and Offset	4-4
4-13	Sine Characteristics	4-6
4-14	Pulse Characteristics	4-8
4-15	Ramp Characteristics	4-9
4-16	Gate and Trigger Performance	4-10
4-17	FM	4-12
4-18	Sweep (Option 002 only)	4-13
4-19	Amplitude Modulator (Option 002 only)	4-15
4-20	Store/Recall Capability	4-16
4-21	HP-IB Capability	4-17
Section 5	Adjustments	
5-1	Introduction	5-1
5-3	Safety Considerations	5-1
5-9	Equipment Required	5-1
5-11	Adjustment Procedure	5-1
5-14	Adjustment Record	5-1
5-16	Adjustments	5-1
5-17	Power Supplies	5-2
5-18	VCO	5-2
5-19	Output Amplifier and Offset Generator	5-4
5-20	High Frequency Adjustments	5-6
5-21	VCO Control	5-7
5-22	Reference Loop	5-8
5-23	Baseline Centering	5-8
5-24	Sweep Generator	5-9
5-25	Amplitude Modulation	5-10
Section 6	Replaceable Parts	
6-1	Introduction	6-1
6-3	Abbreviations	6-1
6-5	Replaceable Parts	6-1
6-8	Ordering Information	6-1
Section 7	Backdating	
7-1	Introduction	7-1
7-3	Change Sequence	7-1

Section 8	Service	Page
8-1	Introduction	8-1
8-4	Safety Considerations	8-1
8-6	After Service Safety Check	8-1
8-15	Service Blocks (Theory/Troubleshooting)	8-1
8-18	IC Information	8-2
8-20	Board Exchange Program	8-2
Service Block 1	Troubleshooting Tree/Device Bus Transfer	8-21
Service Block 2	Burst Generator	8-37
Service Block 3	Frequency Generation	8-47
Service Block 4	Output Amplifier	8-81
Service Block 5	Microprocessor and Display	8-107
Service Block 6	Power Supply	8-129
Service Block 7	Sweep	8-137
Service Block 8	Amplitude Modulator	8-145

ILLUSTRATIONS

Figure	Title	Page
1-1	8165A and Supplied Accessories	1-0
1-2	Available Rack Mounting Accessories	1-0
1-3	Serial Number Plate	1-1
2-1	Switch Settings for the various Nominal Powerline Voltages	2-1
2-2	Power Cable Available: Plug Identification	2-2
2-3	HP-IB Connector	2-2
2-4	Removing Plastic Trim	2-2
3-1	Front and Rear Panel Controls, Connectors and Indicators	3-0
3-2	Normal Mode (50 % duty cycle/symmetry)	3-1
3-3	Normal Mode (20 and 80 % duty cycle/symmetry)	3-1
3-4	Example of Operation in VCO mode	3-2
3-5	VCO Mode Characteristics	3-2
3-6	External Trigger Mode (50 % duty cycle/symmetry)	3-3
3-7	External Trigger Mode (20 and 80 % duty cycle/symmetry)	3-3
3-8	Example of Gate Mode	3-3
3-9	Example of Burst Mode	3-4
3-10	Sweep Mode Characteristics	3-4
3-11	Example of Sweep Mode	3-5
3-12	Example of Triangle Output below 1 kHz	3-5
3-13	Source/Load Configurations	3-6
3-14	Configuration of Output Stage	3-6
3-15	Illustrative Flow Chart	3-13
3-16	Program Example	3-14
4-1 to 4-14	Performance Test Setups	4-2 to 4-17
5-1 to 5-10	Adjustment Location/Waveform Adjustment Diagrams	5-2 to 5-10
6-1	Parts Identification for Main Assembly	6-4
8-1-1	8165A Block Diagram	8-20/8-35
8-1-2	Categories of 8165A Malfunction	8-21
8-1-3	Troubleshooting Tree	8-22
8-1-4	Device Bus Acceptor Circuit (1 load pulse)	8-24
8-1-5	Device Bus Acceptor Circuit (3 load pulses)	8-24
8-1-6	Device Bus Test Setup	8-25
8-2-1	Burst Generator Block Diagram	8-38
8-2-2	Burst Timing Diagram	8-39
8-3-1	Frequency Generation Block Diagram	8-46
8-3-2	Ramp Generation	8-48
8-3-3	Positive Source Switching	8-48
8-3-4	Main VCO Timing and Enablement	8-49
8-3-5	Basic PLL Frequency Synthesizer	8-50
8-3-6	Typical Variable Frequency Synthesizers	8-51
8-3-7	Frequency Synthesis in the 8165A	8-52
8-3-8	LF Generator: Block Diagram	8-53
8-3-9	Triangle Generator, Up/Down Logic	8-54
8-3-10	Operation in Trigger Mode	8-55
8-3-11	Count Enable in Gate and Burst Modes	8-56
8-3-12	Sine Operation	8-57
8-3-13	Square/Pulse Operation	8-57

ILLUSTRATIONS

Figure	Title	Page
8-3-14	Triangle/Ramp Operation and Output Driver	8-58
8-3-15	VCO Functional Diagram	8-60
8-3-16	Triangle Voltage Window at TP5	8-60
8-3-17	Timing diagram for Trigger/Gate/Burst Control	8-62
8-3-18	Sine Shaper Waveforms	8-63
8-3-19	Sine Shaper Waveforms	8-63
8-3-20	Block Diagram of Duty Cycle Logic	8-64
8-3-21	Example: LF Generator Output 1 Hz	8-65
8-3-22	Block Diagram of LF Generator Counter	8-65
8-3-23	Timing Diagram for LF Generator Counter	8-65
8-3-24	Start/Stop Circuit	8-66
8-3-25	Trigger Mode	8-66
8-3-26	Gate Mode	8-66
8-3-27	PLL Block Diagram	8-67
8-3-28	Waveform Loop 1	8-67
8-3-29	Waveform Loop 2	8-68
8-3-30	Waveforms (VCO frequency 100 kHz)	8-69
8-3-31	Waveforms (VCO frequency 100 kHz)	8-69
8-4-1	Output Amplifier Block Diagram	8-81
8-4-2	Operating Principle for Each Stage of Active Vernier	8-82
8-4-3	Functional Diagram of Active Vernier Current Source	8-83
8-4-4	Inter-relationship of Active Vernier Stages	8-84
8-4-5	Power Amplifier Block Diagram	8-85
8-4-6	Switchable Amplifier Functional Diagram	8-86
8-4-7	Attenuator Ranges	8-87
8-4-8	Offset Generator Block Diagram	8-88
8-4-9	Active Vernier	8-89
8-5-1	Controller Block Diagram	8-108
8-5-2	Control Line and Interface	8-109
8-5-3	Microprocessor Pre-conditions	8-111
8-5-4	μ P Clock	8-112
8-5-5	Power On/Re-start	8-112
8-5-6	Flowchart	8-112
8-5-7	Address Bus Signatures	8-113
8-5-8	Address Decoder IC's	8-113
8-5-9	Data Bus IC's	8-114
8-5-10	Display Flowchart	8-114
8-5-11	Section of Microprocessor Board A3	8-115
8-5-12	U40 Timing in NORM Operation	8-116
8-5-13	Keyboard Scanner Timing Cycle	8-117
8-6-1	Principle of Fixed Voltage Regulator	8-130
8-6-2	Reference Shutdown Circuit	8-130
8-6-3	Heat-sink Dis-assembling	8-131
8-6-4	Heat-sink Rear-view	8-131
8-7-1	Sweep Block Diagram	8-137
8-7-2	Start/Stop Data Set for Max. Output Signal	8-140

ILLUSTRATIONS

Figure	Title	Page
Service Sheet 1	Ext Input, Burst Counter; A7	8-36
Service Sheet 2	VCO; A5, A8	8-44
Service Sheet 3	LF Generator; A10	8-78
Service Sheet 4	Amplitude, Offset, Output Amplifier; A4, A6, A12	8-80
Service Sheet 5	PLL; A9	8-98
Service Sheet 6	VCO Control; A8	8-103
Service Sheet 7	HP-IB Interface; A14	8-104
Service Sheet 8	Microprocessor, Memory and Displays; A1, A2, A3	8-106
Service Sheet 9	Power Supplies; A4, A6	8-128
Service Sheet 10	Sweep Generator	8-136
Service Sheet 11	Amplitude Modulation	8-144

TABLES

Table	Title	Page
1-1	Recommended Test Equipment	1-2
1-2	Specifications	1-3
3-1	Bands in VCO Mode	3-3
3-2	Bands in Sweep Mode	3-4
3-3	Output Voltage Summary	3-6
3-4	Available Addresses	3-8
3-5	Mode and Parameter-setting Messages	3-9
3-6	Control Messages and Commands	3-12
3-7	Error Messages	3-12
3-8	Code Assignments for the 8165A	3-15
4-1	Performance Test Record	4-18
5-1	Adjustment Record	5-17
6-1	Abbreviations for Replaceable Parts	6-2
6-2	Manufacturer's Codes	6-4
6-3	Replaceable Parts	6-5
7-1	Manual Backdating Changes	7-1
8-1	Index to Assemblies	8-1
8-2	Index to Service Blocks	8-1
8-3	Schematic Diagram Notes	8-2
8-4	IC Information	8-5
8-1-1	Internal Bus Device Addresses	8-25
8-1-2	Input Mode Data Transfer	8-26
8-1-3	Input Mode Data Function	8-27
8-1-4	Waveform Data Transfer	8-28
8-1-5	Duty Cycle De-coding	8-29
8-1-6	Amplitude Data Transfer	8-29
8-1-7	Amplitude D/A Converter Table	8-30
8-1-8	Complete Amplitude Data (50 Ω / 50 Ω)	8-30
8-1-9	Output Mode Data	8-31
8-1-10	Offset Data	8-31
8-1-11	Sweep Mode Data Transfer	8-31
8-1-12	Sweep Mode	8-32
8-1-13	Sweep Start/Stop Data Transfer	8-32
8-1-14	Start/Stop Data	8-33
8-1-15	Sweep Time Data Transfer	8-33
8-1-16	Sweep Time Data	8-34
8-2-1	Input Mode Table	8-39
8-2-2	Burst Data Transfer	8-39
8-3-1	FRQ Display to Voltage	8-59
8-3-2	FRQ Range to VCO Input	8-59
8-3-3	Current Source Linearity	8-61
8-3-4	VCO Ranges	8-61
8-3-5	Capacitor Ranges	8-61
8-3-6	Duty Cycle Ranges	8-61
8-3-7	U101 Truth Table	8-62
8-3-8	Waveform Control	8-63
8-3-9	Frequency Ratio Table	8-64

TABLES

Table	Title	Page
8-3-10	Duty Cycle Switching	8-65
8-3-11	LF Mode Selection	8-66
8-3-12	Loop 1 (95 kHz – 540 kHz)	8-67
8-3-13	Loop 2 (8.01 MHz – 9.00 MHz)	8-68
8-3-14	Divider Settings	8-69
8-4-1	D/A Converter Voltage to Current Table	8-89
8-4-2	Complete Current Range Table	8-89
8-4-3	Amplitude Ranges p-p (1 k Ω / 50 Ω)	8-90
8-4-4	Amplitude Ranges p-p (50 Ω / 50 Ω)	8-90
8-4-5	Attenuator Ranges	8-90
8-4-6	Norm-Inverting	8-91
8-4-7	D/A Converter Voltage Table (50 Ω / 50 Ω)	8-91
8-4-8	D/A Converter Table (1 k Ω / 50 Ω)	8-91
8-4-9	Offset Polarity and Range	8-92
8-5-1	Address Decoder Signatures	8-113
8-5-2	ROM and Data Bus Signatures	8-114
8-5-3	Display Signatures	8-115
8-5-4	Display RAM Signatures	8-117
8-7-1	Sweep Mode Data Transfer	8-138
8-7-2	Sweep Mode	8-138
8-7-3	Sweep Time Data Transfer	8-138
8-7-4	Start/Stop Data Transfer	8-139
8-7-5	Start/Stop Data-Output Voltage	8-140

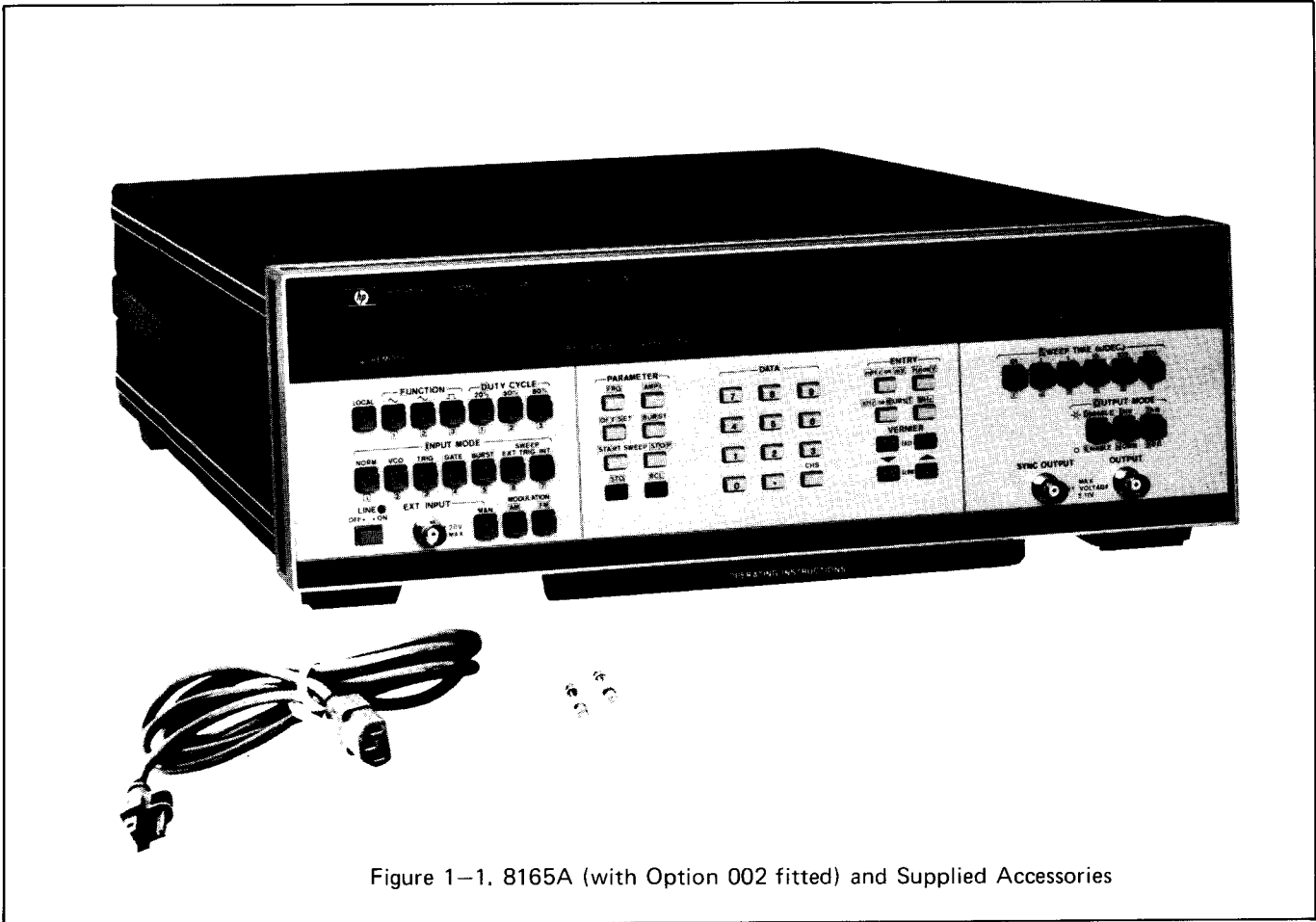
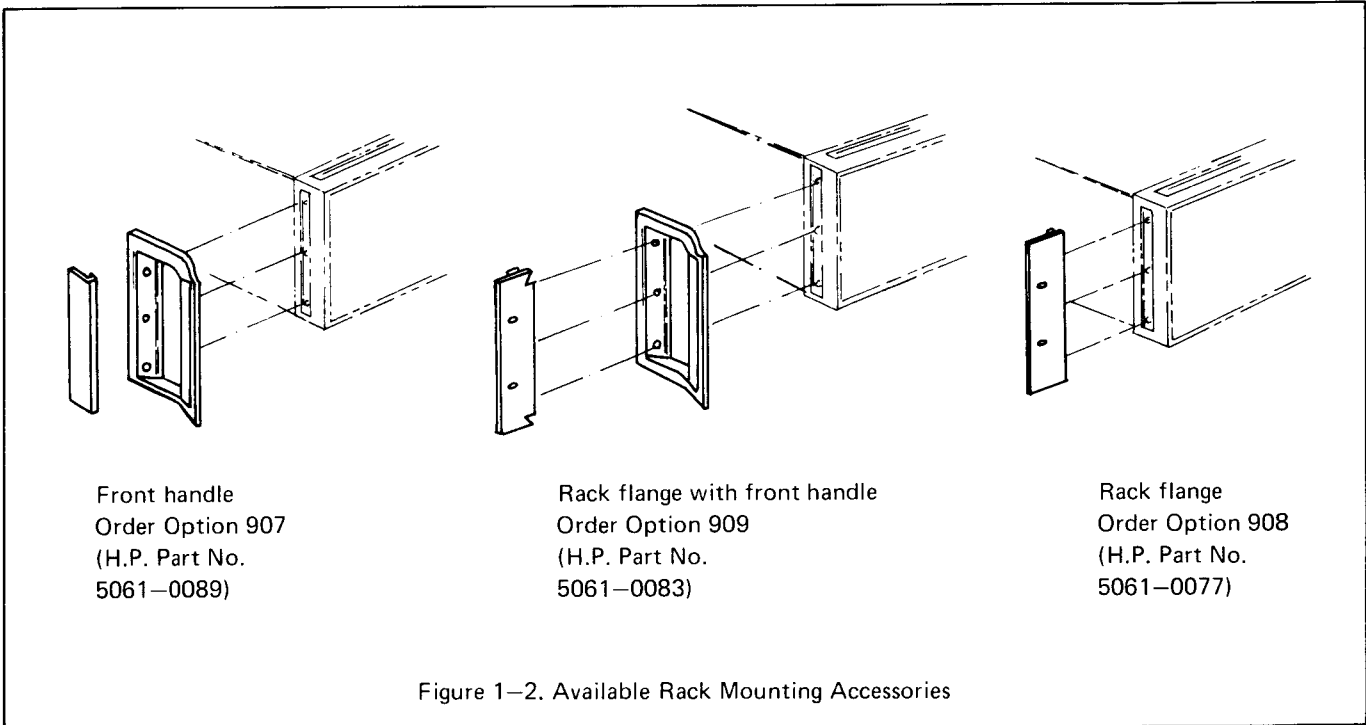

Figure 1-1. 8165A (with Option 002 fitted) and Supplied Accessories



Front handle
Order Option 907
(H.P. Part No.
5061-0089)

Rack flange with front handle
Order Option 909
(H.P. Part No.
5061-0083)

Rack flange
Order Option 908
(H.P. Part No.
5061-0077)

Figure 1-2. Available Rack Mounting Accessories

SECTION I GENERAL INFORMATION

1-1 INTRODUCTION

1-2 This Operating and Service Manual contains information required to install, operate, test, adjust and service the Hewlett-Packard Model 8165A. Figure 1-1 shows the mainframe and accessories supplied. This section covers instrument identification, description, accessories, specifications, and other basic information.

1-3 A Microfiche version of this manual is available on 4 x 6 inch microfilm transparencies (order number on title page). Each microfilm contains up to 60 photoduplicates of the manual pages. The microfiche package also includes the latest Manual Changes supplement as well as all pertinent Service Notes.

1-4 SPECIFICATIONS

1-5 Instrument specifications are listed in Table 1-2. These specifications are the performance standards or limits against which the instrument is tested.

1-6 SAFETY CONSIDERATIONS

1-7 The Model 8165A is a Safety Class 1 instrument (it has an exposed metal chassis that is directly connected to earth via the power supply cable).

1-8 This operating and service manual contains information, cautions, and warnings which must be followed by the user to ensure safe operation and to maintain the instrument in a safe condition.

1-9 INSTRUMENTS COVERED BY MANUAL

1-10 Attached to the rear of this instrument is a serial number plate (Figure 1-3). The first four digits of the serial number only change when there is a significant change to the instrument. The last five digits are assigned to instruments sequentially. The contents of this manual apply directly to the instrument serial number quoted on the title page. For instruments with lower serial numbers, refer to the backdating information in Section VII of this manual. For instruments with higher serial numbers, refer to the Manual Change sheets at the end of this manual. In addition to change information, the

Manual Change sheets may contain information for correcting errors in the manual. To keep this manual as up-to-date and accurate as possible, Hewlett-Packard recommends that you periodically request the latest Manual Change supplement. The supplement for this manual is identified with this manual's print date and part number, both of which appear on this manual's title page. Complimentary copies of the supplement are available from Hewlett-Packard.

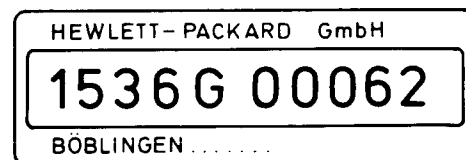

Figure 1-3. Serial Number Plate

1-11 DESCRIPTION

1-12 The HP Model 8165A Programmable Signal Source provides sine, triangle and square waveforms in the frequency range 1 mHz to 50 MHz. Operating modes include: normal (internal trigger), voltage-controlled oscillator, external trigger, gate, burst and FM. Output capabilities include normal/invert, selectable source impedance, variable offset up to ± 10 V and variable amplitude up to ± 20 Vpp. Microprocessor design makes mode selection and parameter setting easy whether done manually or programmed over the HP-IB*. Current operating status, including notification of operating or programming error, is available to the bus and indicated on the front panel.

* Hewlett-Packard Interface Bus, Hewlett-Packard's implementation of IEEE Standard 488 „Standard Digital Interface for Programmable Instrumentation“.

1-13 OPTIONS

1-14 **8165A Option 002** provides additional AM feature and up/down logarithmic sweep modes. The sweep modes have selectable start and stop frequencies and the sweep time may be selected from six discrete values. Sweep start may be externally triggered or, for continuous operation, internally triggered.

NOTE: Option 001 (additional sweep mode only) is obsolete. Refer to Backdating.

1-15 8165A Options 907, 908 and 909 provide handles and/or rack mounting accessories. Refer to Figure 1-2.

1-16 8165A Option 910 provides an additional manual.

1-17 All options will be delivered with the instrument if ordered at the same time as the instrument.

1-18 ACCESSORIES SUPPLIED

1-19 The 8165A is supplied complete with the following items (see Figure 1-1):

ITEM	HP PART NUMBER
1A Fuse for 230V operation	2110-0001
2A Fuse for 115V operation	2110-0002
Power cable	see Figure 2-2
User's Reference (inserted in pull-out under instrument)	08165-90011

1-20 RECOMMENDED TEST EQUIPMENT

1-21 Equipment required to maintain the model 8165A is listed in Table 1-1. Other equipment can be substituted if it meets or exceeds the critical specifications listed in the table.

Table 1-1 Recommended Test Equipment

INSTRUMENT	RECOMMENDED MODEL	REQUIRED CHARACTERISTICS	USE*
Counter	HP5345A	50 uHz to 50 MHz, 8 digit display	P, A
Digital voltmeter	HP3455A	0.1-20 V, ac rms and dc. 0.004% accy.	P, A
Spectrum analyzer	HP181A + 8557A or HP141T + 8552A + 8556A	1 - 50 MHz	P, A
Spectrum analyzer	HP3580A	100 Hz - 1 MHz	A
Sampling scope	TEK7603 with 7T11/7S11 and S-3A	Dual channel, 2 mV/div, 10 ps - 50 us/div.	P, A
Scope	HP1740A	100 MHz bandwidth	P, A
Pulse/Function generator	HP8116A	1 Hz-1 MHz, square, pulse, offset, sine	P, A
Voltage source	HP6213A	100 mV - 10 V dc	P, A
System controller	HP9825A+98034A	Desktop computer, HP-IB interface	P
Logic analyzer	HP1600A	16-bit	T
Logic probe	HP545A	TTL, MOS	T
Cable assembly (3)	HP11170B	50 Ohm, 61 cm (24 in), BNC	P, A
Cable assembly (2)	HP11170A	50 Ohm, 30 cm (12 in), BNC	P, A
Feedthrough termination	HP10100C	50 Ohm, BNC	P, A
Power attenuator	NARDA 766-20	20 dB, 20 W	P, A
BNC Tee	HP1250-0781	1 male, 2 female	P, A
Adapter	HP1251-2277	Banana/BNC female	P, A
1:1 Probe	HP10007/8B	BNC/retractable hook	A
10:1 Probe	HP10006B	BNC/retractable hook	A
Capacitor	HP0160-372	0.47 uF	A
Extender board	09865-66514	24 pin	T
Extender board	5060-0630	22 pin	T
Extender board	HP5060-1742	18 pin	T
Extender board	5060-0258	12 pin	T
Extender board	5060-0651	6 pin	T
Power meter	HP436A	100 k - 50 MHz	P, A
Power sensor	HP8482A	1 uW - 100 mW, 100 kHz - 50 MHz	P, A

* P = Performance Test; A = Adjustments; T = Troubleshooting

Table 1-2 Specifications

Frequency Characteristics

Waveforms: Sine, square, pulse, triangle, ramp.
Range: 0.001 Hz to 50.00 MHz (0.001 Hz to 19.99 MHz for 20 and 80% duty cycle/symmetry).

Accuracy, Stability and Resolution:

	Norm	Trig. Gate, Burst	
		f < 1 kHz	f ≥ 1 kHz
Accuracy	0.001% *	0.001%*	5%
Stability over 1 hour	± 1x10 ⁻⁶ *	± 1x10 ⁻⁶ **	± 5x10 ⁻⁴ **
Stability over 24 hours	± 1x10 ⁻⁶ *	± 1x10 ⁻⁶ **	± 1x10 ⁻³ **
Resolution (digits)	4	4	3

* Accuracy and stability can be improved by phase locking to an external frequency reference.

** After 15 minutes.

Jitter: ≤ 0.2% at 20/80% duty cycle/symmetry
 ≤ 0.1% (≥ 1 kHz)
 ≤ 0.02% (0.1 Hz – 999 Hz), further improvement at lower frequencies.

Output Characteristics

(50 Ω Source terminated by 50 Ω load unless stated otherwise)

Range: amplitude and offset independently variable within ± 10 V.

Source Impedance: selectable 50 Ω ± 1% or 1 kΩ ± 10%, in parallel with 50 pF.

Amplitude: 10.0 mV_{pp} to 10.0 V_{pp},
 2.00 V_{pp} to 20.0 V_{pp} (1 k Ω into 50 Ω).

Accuracy	Sine V _{Rms}	Square	Triangle (50%)	Ramp 20%-80%	Pulse 20%-80%
< 1 kHz	+/- 3%	+/- 2%	+/- 3%	+/- 3%	+/- 2%
1 kHz - 4.99 MHz	+/- 3%	+/- 2%	+/- 3%	+/- 5%	+/- 2%
5 MHz - 19.9 MHz	+/- 8%	+/- 5%	+/- 10%	+/- 10%	+/- 5%
20 MHz - 50 MHz	+/- 8%	+/- 5%	+5% to -20%		

Resolution: 3 digits.

Offset: 0 to ± 5.00 V,
 0 to ± 10.0 V (1 kΩ into 50 Ω).

Accuracy: ± (1% programmed value + 1% signal V_{pp} + 20 mV).

Resolution: 2 digits (10 to 99 mV), 3 digits (≥ 100 mV).

Baseline Drift (Trig, Gate and Burst modes): ≤ 5% of peak amplitude.

Sine Characteristics (Norm mode):

Harmonic Components: Up to 5 MHz, THD < 1% of fundamental. Above 5 MHz, all harmonics at least 30 dB below fundamental.

Spurious: all non-harmonically related outputs at least 40 dB below fundamental.

Triangle/Ramp Characteristics

Symmetry: 20, 50, 80% selectable.

Linearity: (10% to 90%): ± 1% (up to 5 MHz),
 ± 5% (above 5 MHz).

cont'd.

Square/Pulse Characteristics:

Duty cycle: 20, 50, 80% selectable.

Transition times (10% to 90%): < 5 ns,
 < 7 ns (1 kΩ into 50 Ω).

Preshoot/Overshoot/Ringing: ± 5%,
 ±10% (1 kΩ into 50 Ω).

Operating Modes

Norm: continuous waveform is generated, phase locked to an internal 10 MHz crystal reference.

VCO: external voltage (100 kHz max) from 10 mV to 10 V linearly sweeps 3 decades up to top of decade in which the 8165A frequency is set. Four bands limited to less than 3 decades:

- 100 mV – 10 V for 100 kHz – 10 MHz and 10 Hz – 1 kHz,
- 10 mV – 2 V for 100 kHz – 20 MHz,
- 50 mV – 5 V for 500 kHz – 50 MHz.

Trig: pos. ext input pulse ≥ 10 ns wide generates one output cycle. Upper level ≥ +250 mV, lower level ≤ 0V.

Gate: oscillator-enabled when ext input ≥ +250 mV, disabled when ≤ 0 V. First and last output cycles are always complete.

Burst: a preprogrammed number of output cycles is generated. Min. time between bursts 50 ns. Burst length 0 to 9999 cycles. Min. trigger pulse width 10 ns, upper level ≥ + 250 mV, lower level ≤ 0 V.

FM: 0 to ± 1 V modulates 0 to ± 1% deviation.

Modulating Frequency: 100 Hz to 20 kHz (Norm mode), dc to 20 kHz (Gate mode with carrier frequency ≥ 1 kHz).

Input Impedance: 10 kΩ typical.

AM (Option 002 only): 0 to 2.5 V_{pp} modulates 0 to 100% modulation depth.

Modulating Frequency: dc to 10 MHz (-3 dB).

Input Impedance: 10 kΩ typical.

Pulse Modulation: transition times < 50 ns.

Envelope Distortion (dc to 250 kHz mod. freq.):

Carrier	Modulation	Distortion
≤ 1 MHz	0 to 90%	< 1%
> 1 MHz	0 to 30%	< 3%

Carrier Frequency Deviation: < 0.01%, 0 to 30% modulation.

Sweep (Option 002 only): provides logarithmic up/down sweep up to 3 decades between limits set on the 8165A. As in VCO mode, 4 bands limited to less than 3 decades. Min frequency 1 mHz.

Sweep-rate: 0.01, 0.1, 1, 10, 100, 1000 seconds per decade selectable.

Trigger: one up-down sweep per trigger pulse (upper level ≥ +250 mV, lower level ≤ 0 V, width ≥ 10 ns).

Accuracy: sweep start frequency ± (15% + 0.5% of max. stop frequency), sweep stop frequency ± 15%.

Resolution: 2 digits.

Table 1-2 Specifications (continued)

Auxiliary outputs and inputs

Ext. Input: external signals used in VCO, Trig, Gate, Burst and (Option 001) Sweep ext. trig.
Signal range in VCO: 10 mV to 10 V for 3-decade sweep.
Signal thresholds in Trig, Gate, Burst, Sweep ext trig: +250 mV (upper), 0 V (lower).
Max. input: ± 20 V,
Input impedance: 10 kΩ typical.

Sync. output: one trigger pulse per main output cycle.
Amplitude: 3 V_{pp} into open circuit (1.5 V_{pp} into 50 Ω).

Ext. 10 MHz ref.: external 10 MHz, TTL, system clock.
 Rear panel switch selects ext or int clock as instrument reference.

Mod Inp: FM and (Option 002 only) AM input.
Signal range in FM: 0 to ± 1 V for 0 to ± 1% deviation.
Signal range in AM: 0 to 2.5 V_{pp} for 0 to 100% modulation depth.
Max. input: ± 20 V.
Input impedance: 10 kΩ typical.

Sweep out (Option 002 only): triangular sweep voltage, 0 to 2.99 V amplitude for 3 decades (1 V/decade).

HP-IB capability and microprocessor

Code	Interface Function	Code	Interface Function
SH 1	Source Handshake	SR 1	Service Request
AH 1	Acceptor Handshake	RL 1	Remote/Local
T 6	Talker (basic talker, serial poll, unaddress to talk if addressed to listen)	PP 0	No Parallel Poll
		DC 0	No Device Clear
		DT 1	Device Trigger
		C 0	No Controller
L 4	Listener (Basic listener, unaddress to listen if addressed to talk)	E 1	Three-state Bus Drivers

Accuracy: See Frequency and Output Characteristics

Settling times:
Frequency: < 20 ms to ± 5% of programmed value. In Norm mode, and in Trig, Gate, Burst at frequencies < 1 kHz : < 70 ms to ± 2% of programmed value, < 300 ms to final value.
Other Functions: 20 ms. The following range changes can take up to 200 ms:
 Change of duty cycle.
 Selection to or from Sweep/VCO.
 Changing up to/down from the following decades:
 Frequency 1 kHz, 10 kHz, 100 kHz, 1 MHz, 20 MHz.
 Amplitude 100 mV, 1 V
 Offset 1 V.

Number of bytes sent/received
Listener: up to 65 bytes (89 in Option 002) for one complete set of operating parameters.
Talker-Learn Mode: 8 lines. Each line up to 16 bytes plus CR LF. Total: 144 bytes max.
Talker-Error Message: 1 byte.

Byte Rate:
Function Time (typical values): set up as talker/listener 1.1 ms, receiving time per character 0.1 ms, processing per parameter 3.0 ms, entry time per digit 2.0 ms, check time per parameter entry 5-10 ms, waveform/duty cycle/modulation 1.0 ms, input mode 6.5 ms, output modes 9.0 ms, recall 25 ms, store 380 ms.

Memory: 10 addressable locations plus one for existing operating state.
Capacity: each location can store a complete set of operating parameters and modes.
Access time: 20 ms each location.
Storage time: internal battery provides memory retention for approx. 4 weeks at room temperature. Battery re-charges when 8165A is switched on.

General

Power Requirements: 100 V, 120 V, 220 V or 240 V; +5 V to -10%, 48 to 66 Hz, 200 VA max.

Environmental: operates to specifications from 0 to 50°C, and with relative humidity to 95% at 40°C.
Storage: -20 to +70°C.

Weight: net 12 kg (26.5 lbs.). Shipping 16 kg (35.3 lbs.).

Dimensions: 426 mm wide, 145 mm high, 450 mm deep (16.8 x 5.7 x 17.7 inches).

Accessories Available: The following cables for interconnecting HP-IB instruments to the bus are available:

10631A	1 m (3.28 ft)	10631C	4 m (13.1 ft)
10631B	2 m (6.56 ft)	10631D	0.5 m (1.64 ft)

The following adapters for connecting to the DUT are available:

15104A	Adder/Splitter
15450A	Adapter for terminating at DUT
15451A	TTL-CMOS Translator. CMOS level originates from DUT thus protecting it.

OPTIONS
Option 002: Sweep and Amplitude Modulation
Option 003: Rear Panel I/O
Option 907: Front Handle Kit, p.n. 5061-0089
Option 908: Rack Mounting Kit, p.o. 5061-0077
Option 909: Combined Front Handle and Rack Mounting Kit, p.n. 5061-0083
Option 910: extra Operating and Service Manual

Specifications describe the instrument's warranted performance. Supplement characteristics - identified by the word "typical" - are intended to provide information useful in applying the instrument by giving typical, but non-warranted, performance parameters.

Data subject to change

SECTION II INSTALLATION

2-1 INTRODUCTION

2-2 This section provides installation instructions for the instrument and its accessories. It also includes information about initial inspection and damage claims, preparation for use, and packaging, storage and shipment.

2-3 INITIAL INSPECTION

2-4 Inspect the shipping container for damage. If the container or cushioning material is damaged, it should be kept until the contents of the shipment have been checked for completeness and the instrument has been checked mechanically and electrically. The contents of the shipment should be as shown in Figure 1-1 plus any accessories that were ordered with the instrument. Procedures for checking the electrical operation are given in Section 3. If the contents are incomplete, if there is mechanical damage or defect, or if the instrument does not pass the operator's checks, notify the nearest Hewlett-Packard office. Keep the shipping materials for carrier's inspection. The HP office will arrange for repair or replacement without waiting for settlement.

2-5 PREPARATION FOR USE

2-6 Power Requirements

2-7 The instrument requires a power source of 100V, 120V, 220V or 240V (+5%, -10%) at a frequency of 48 to 66 Hz single phase. The maximum power consumption is 200 VA.

2-8 Line Voltage Selection



BEFORE SWITCHING ON THIS INSTRUMENT make sure that the instrument is set to the local line voltage.

2-9 Figure 2-1 provides information for line voltage and fuse selection:

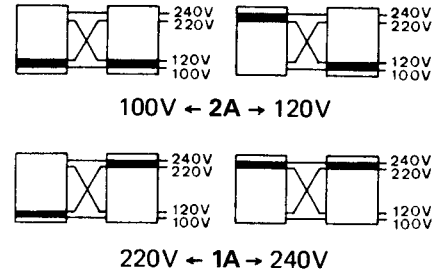

Figure 2-1. Switch Settings for the various Nominal Powerline Voltages

2-10 Power Cable



To avoid the possibility of injury or death, the following precautions must be followed before the instrument is switched on:

- a. *If this instrument is to be energized via an auto-transformer for voltage reduction, make sure that the common terminal is connected to the neutral pole of the power source (non-symmetrical supplies). Ensure that the ground connection is preserved.*
- b. *The power cable plug shall only be inserted into a socket outlet provided with a protective ground contact. The protective action must not be negated by the use of an extension cord without a protective conductor.*
- c. *Before switching on the instrument, the protective ground terminal of the instrument must be connected to a protective conductor of the power cable. This is verified by checking that the resistance between the instrument chassis and the front panel and the ground pin of the power cable plug is zero ohms.*

2-11 In accordance with international safety standards, this instrument is equipped with a three-wire power cable. When connected to an appropriate ac power receptacle,

this cable grounds the instrument cabinet. The type of power cable shipped with each instrument depends on the country of destination. Refer to Figure 2-2 for the part number of the power cords available.

2-12 If the plug on the cable supplied does not fit your power outlet, then cut the cable at the plug end and connect a suitable plug. The plug should meet local safety requirements and include the following features:

- Minimum current rating of 2A
- Ground connection
- Cable clamp.

The colour coding used in the cable will depend on the cable supplied (see Figure 2-2).

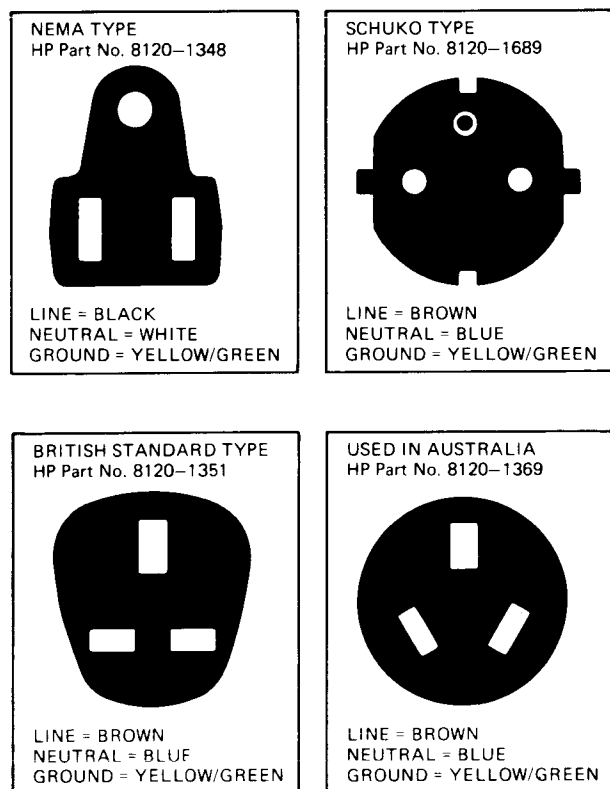

Figure 2-2. Power Cables Available: Plug Identification

2-13 HP-IB Connector

2-14 The rear panel HP-IB connector (Figure 2-3) is compatible with the connectors on Cable Assemblies 10631A, B, C and D. If a cable is to be locally-manufactured, use connector male, HP part number 1251-0293.

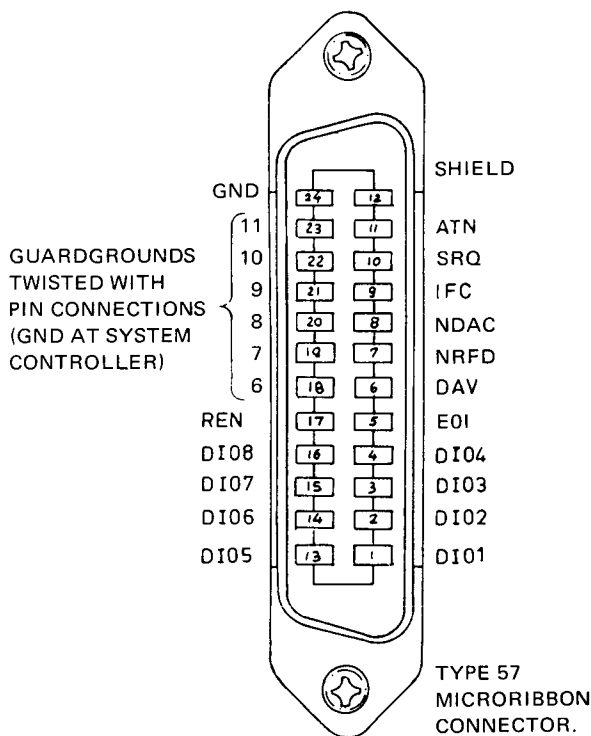

Figure 2-3. HP-IB Connector

2-15 HP-IB Logic Levels

2-16 The 8165A HP-IB lines use standard TTL logic. Logic levels are as follows:

- True = low = digital ground or 0V dc to +0.4V dc,
- False = high = open or +2.5V dc to +5V dc.

All HP-IB lines have LOW assertion ("1") states. High states are held at +3V dc by pullups within the instrument. When a line functions as an input, approximately 3.2mA of current is required to pull it low through a closure to digital ground. When a line functions as an output, it will sink up to 48mA in the low state and approximately 0.6mA in the high state.



Isolation. The HP-IB line screens are not isolated from outer chassis (frame) ground.

2-17 Operating Environment

2-18 The instrument will operate within specifications when the ambient temperature is between 0°C and 50°C.

2-19 FRONT HANDLE/RACK MOUNTING

2-20 Figure 1-2 shows the possible handle/rack-mounting configurations. If handles are fitted and subsequently need to be removed, the plastic trim must first be taken off as shown in Figure 2-4.

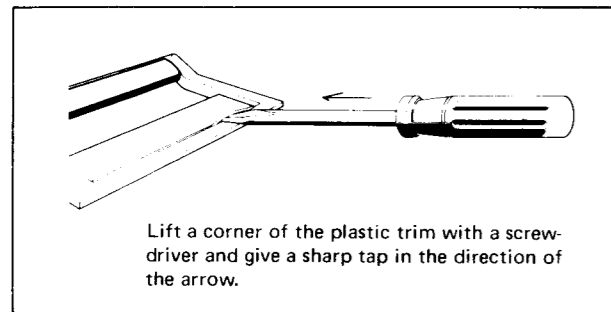

Figure 2-4. Removing Plastic Trim

2-21 USE OF REAR PANEL CONNECTORS

2-22 The 8165A is supplied with a duplicate set of BNC connectors on the rear panel (Figure 3-1) which are not connected internally. If, typically in a rack environment, any or all of the front panel BNC inputs or outputs are preferred to be taken via the rear panel instead, the instrument covers must be removed (switch off power and disconnect from supply) and the internal leads on the rear panel BNC's substituted for those of front panel.

2-23 CLAIMS AND REPACKAGING

2-24 Claims for Damage

2-25 If physical damage is evident or if the instrument does not meet specification when received, notify the

carrier and the nearest Hewlett-Packard Sales/Service Office. The Sales/Service Office will arrange for repair or replacement of the unit without waiting for settlement of the claim against the carrier.

2-26 Storage and shipment

2-27 The instrument can be stored or shipped at temperatures between -20°C and 70°C . The instrument should be protected from temperature extremes which cause condensation within the instrument.

2-28 If the instrument is to be shipped to a Hewlett-Packard Sales/Service Office, attach a tag showing owner, return address, model number and full serial number and the type of service required. The original shipping carton and packaging material may be re-usable but the Hewlett-Packard Sales/Service office will also provide information and recommendations on materials to be used if the original packing is not available or re-usable. General instructions for re-packing are as follows:

1. Wrap instrument in heavy paper or plastic.
2. Use strong shipping container. A double wall carton made of 350-pound test material is adequate.
3. Use enough shock-absorbing material (3 to 4-inch layer) around all sides of instrument to provide firm cushion and prevent movement inside container. Protect control panel with cardboard.
4. Seal shipping container securely.
5. Mark shipping container FRAGILE to encourage careful handling.
6. In any correspondence, refer to instrument by model number and serial number.

8165A OPTION 002
FRONT PANEL

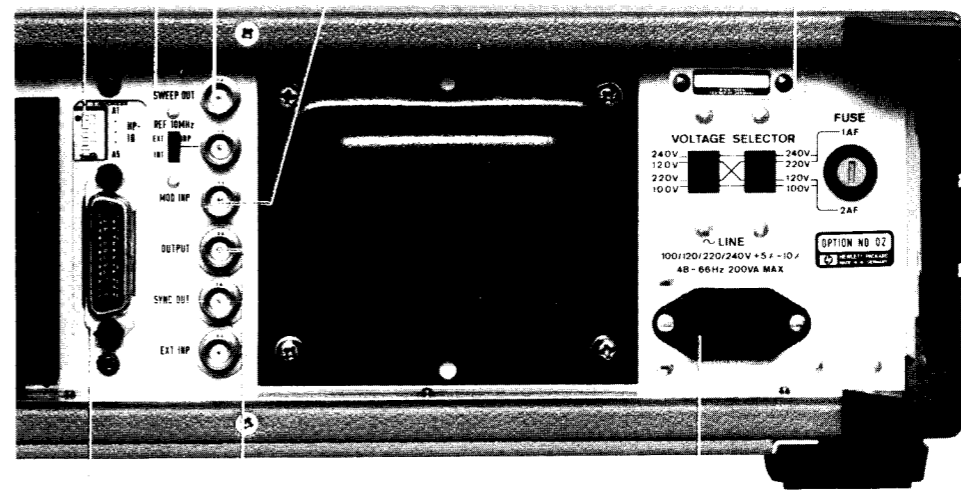
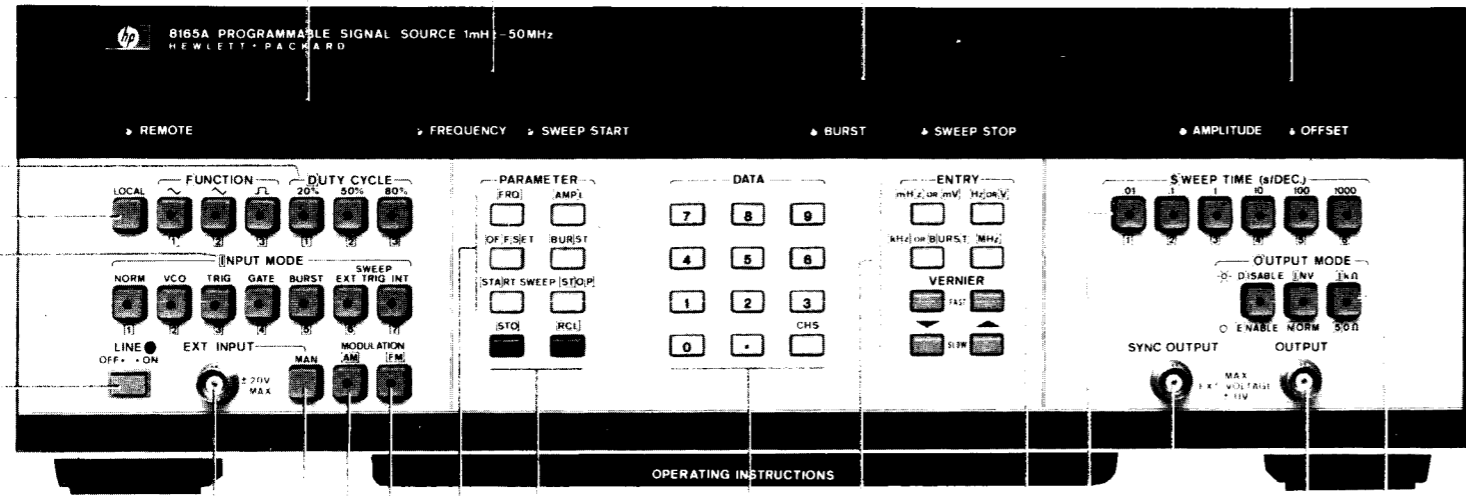

- ① LINE ON/OFF. Primary ac power switch and indicator.
- ② INPUT MODE. Pushbutton selectors for NORM (continuous), VCO (voltage-controlled oscillator), external TRIGGER, GATE and triggered BURST modes. Built-in indicator lights when mode selected. Additional modes in Option 002: SWEEP EXTERNAL TRIGGER and SWEEP INTERNAL TRIGGER (continuous).
- ③ FUNCTION and DUTY CYCLE. Two sets of pushbuttons select output waveform: sine, triangle, square, ramp 20% / 80%, pulse 20% / 80%.
- ④ EXT INPUT. Connector for external signal in VCO, TRIGGER, GATE, BURST and (option 002 only) SWEEP EXTERNAL TRIGGER modes.
- ⑤ MAN. Manual trigger for TRIGGER and BURST modes.

- ⑥ MODULATION FM. Selects frequency modulation.
- ⑦ REMOTE indicator lights when system controller assumes control.
- ⑧ LOCAL RESET push-button enables manual return to local (but see local lockout § 3-73).
- ⑨ ERROR lamp indicates operator or program error.
- ⑩ 4-digit display for frequency and (option 002) sweep start. Lamps indicate magnitude and parameter.
- ⑪ 4-digit display for burst length and (option 002) sweep stop.
- ⑫ 4-digit display for amplitude and offset voltages.
- ⑬⑭⑮ PARAMETER, DATA, ENTRY keys for 3-step operation: select parameter, select data, enter magnitude.

- ⑯ VERNIER keys allow output frequency, amplitude and offset to be varied after selecting parameter.
- ⑰ STO/RCL. Current set of operating modes and parameters can be stored in one of 10 addressable locations by pressing STO key followed by any integer 0-9. Previously stored data can be re-instated by pressing RCL and appropriate integer key.
- ⑱ SWEEP TIME (Option 002 only). Pushbutton selectors for sweep time. Built-in indicators light for selected range.
- ⑲ SYNC OUTPUT. BNC connector providing SYNC OUTPUT signal.
- ⑳ OUTPUT. BNC connector providing signal output.
- ㉑ OUTPUT MODE. Pushbuttons enable/disable output, selects normal or inverted output, 1 kΩ or 50 Ω source impedance. Built-in indicators light for selected status.

- ㉒ MODULATION AM. Selects amplitude modulation (Option 002).
- ㉓ HP-IB address selector.
- ㉔ HP-IB connector.
- ㉕ Connector and switch for external 10 MHz reference.
- ㉖ Modulation input for MOD FM mode and MOD AM mode.
- ㉗ Auxillary connectors for EXT INPUT, SYNC OUTPUT and OUTPUT are fitted on rear panel. These may be connected internally instead of the front panel connectors.
- ㉘ Fuse and line voltage selector.
- ㉙ Line input.

Figure 3-1 Controls and Connectors

SECTION III OPERATION AND PROGRAMMING

3-1 INTRODUCTION

3-2 This section explains the functions of controls, connectors and indicators, and provides operating and programming information. The sweep and AM option (002) is included.

3-3 SPECIAL OPERATING CONSIDERATIONS

3-4 The following steps must be taken before applying power to the Model 8165A.

- a) Read the safety summary at the front of this manual.
- b) Be sure the power selector switches are set properly for the power source being used to avoid instrument damage.
- c) Ensure load is not overdriven (up to 20 V p-p or 400 mA can be delivered).

CAUTION

Do not change the LINE SELECTOR Switch setting with the instrument on or with power connected to the rear panel.

3-5 OPERATORS CHECKS

3-6 Use the performance checks in Section IV to verify proper operation of the 8165A.

3-7 CONTROLS, CONNECTORS AND INDICATORS

3-8 Refer to Figure 3-1.

3-9 OPERATING INSTRUCTIONS

3-10 Operating modes and parameters can be set on the front panel (local operation) or programmed using the HP-IB. The operating modes, selected by pushbuttons with built-in indicators, are explained in the following paragraphs. Signal parameter selection, involving a 3-step operation (select PARAMETER, select DATA, ENTER units) and using a numerical display with a units indicator, is dealt with in § 3-45.

3-11 Commence by setting the LINE switch on and press the DISABLE/ENABLE button (the lamp should

go out, indicating that the output is enabled). The 8165A will have automatically assumed the operating state prevailing at switch-off (see also § 3-59). Should the ERROR lamp flash, an incompatible setting has been attempted and reference should be made to § 3-60.

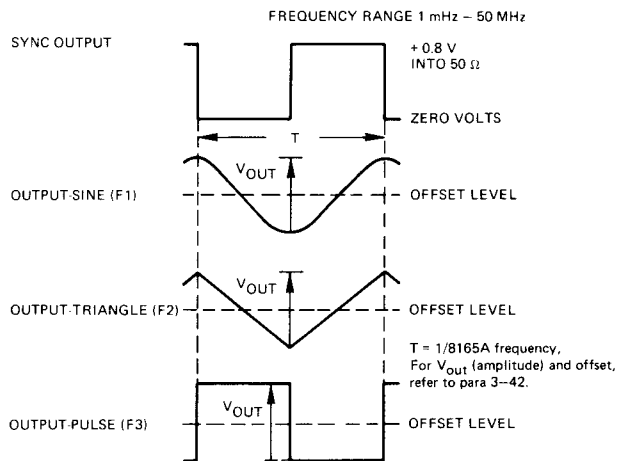

Figure 3-2 Normal Mode (50 % duty cycle/symmetry)

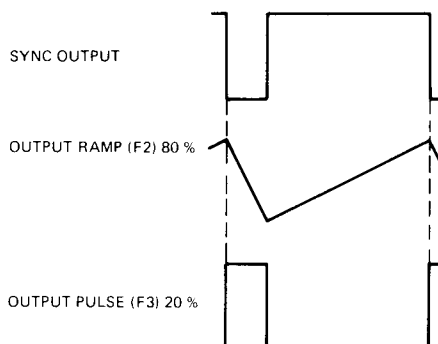
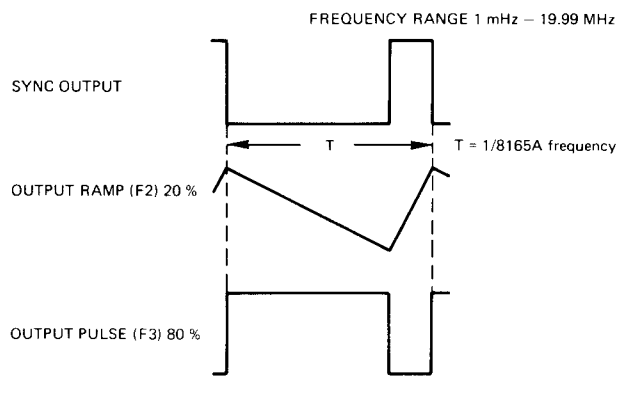

Figure 3-3 Normal Mode (20 and 80% duty cycle/symmetry)

3-12 Function and Duty cycle

3-13 As shown in Figures 3-2 and 3-3, triangular or square wave output with 20, 50 or 80% symmetry/duty cycle, or sine wave may be selected by pressing the appropriate FUNCTION and DUTY CYCLE buttons. The Figures, in which NORM input mode (§3-15) and NORM output (§3-44) are assumed, also shows the relationship between OUTPUT and SYNC OUTPUT.

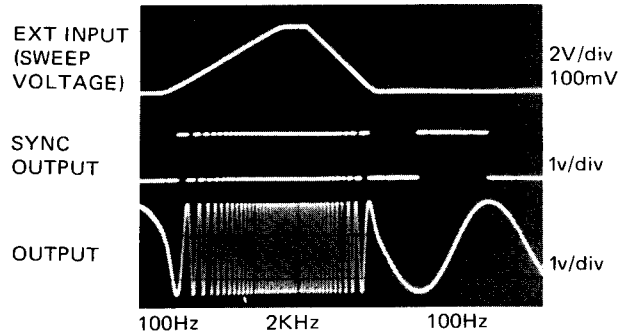

Figure 3-4. Example of operation in VCO mode

3-14 Input Modes (Note: frequency generation above and below 1kHz are dissimilar, see §3-37).

3-15 Normal Mode (NORM) (Figures 3-2, 3-3).

3-16 When normal mode is selected, the output is continuous and its frequency is determined by the FREQUENCY setting (§3-46).

3-17 Voltage-controlled Oscillator Mode (VCO)

3-18 In this mode, a signal applied to the EXT INPUT connector determines the output frequency. The applied signal may change at rates up to 100 kHz. The working

range of input voltage (10 mV – 10V) sweeps the output frequency over a maximum range of 1 : 1000; the actual range swept depends, as shown in Table 3-1, on the 8165A's frequency setting.

3-19 As an example, suppose a sweep from 50 Hz up to 500 Hz is required. This means that, when the 8165A is set to a frequency anywhere in the range 100 Hz – 999 Hz (which brackets the desired sweep maximum), the desired sweep can be obtained by applying an external signal which varies between + 500 mV and + 5 V levels. See Figure 3-5.

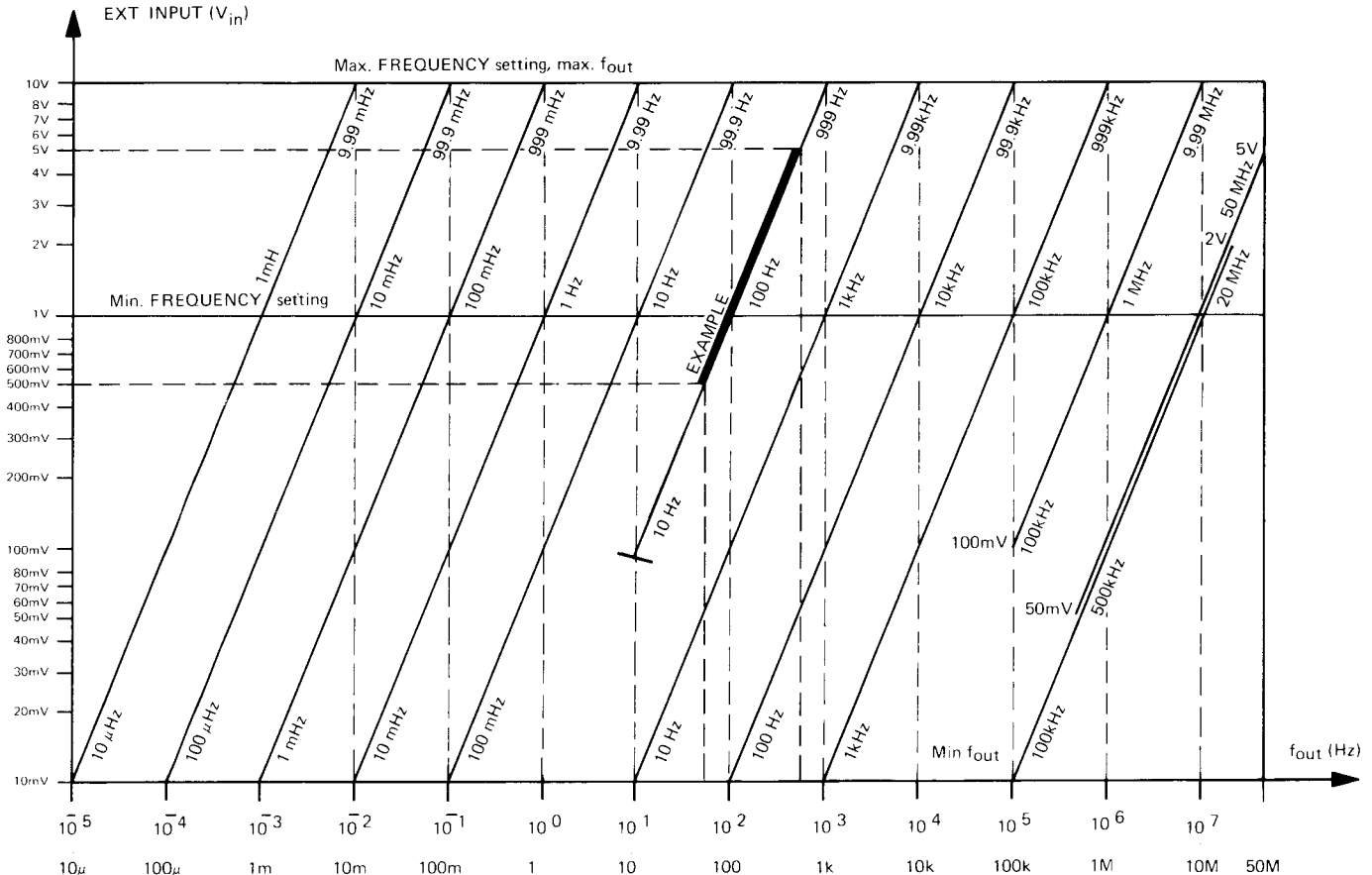

Figure 3-5 VCO mode characteristics

Table 3-1. Bands in VCO Mode

FREQUENCY setting of 8165A	Sweepable band			
	From V_{in} min	f_{out} min	To V_{in} max	f_{out} max
1 mHz – 9.99 mHz	10mV	10 μ Hz	10V	10mHz
10 mHz – 99.9 mHz	10mV	100 μ Hz	10V	100 mHz
100 mHz – 999 mHz	10mV	1mHz	10V	1Hz
1 Hz – 9.99 Hz	10mV	10mHz	10V	10Hz
10 Hz – 99.9 Hz	10mV	100mHz	10V	100Hz
100 Hz – 999 Hz	100mV	10 Hz	10V	1kHz
1 kHz – 9.99 kHz	10mV	10Hz	10V	10kHz
10 kHz – 99.9 kHz	10mV	100Hz	10V	100kHz
100 kHz – 999 kHz	10mV	1kHz	10V	1MHz
1 MHz – 9.99 MHz	100mV	100kHz	10V	10MHz
10 MHz – 19.99 MHz	10mV	100kHz	2V	20MHz
20 MHz – 50 MHz	50mV	500kHz	5V	50MHz

3-20 External Trigger Mode (TRIG)

3-21 When externally triggered, the positive-going edge of the pulse applied to the EXT INPUT connector initiates one complete output cycle (Figure 3-6), the frequency (and also the maximum trigger frequency) being defined by the 8165A's frequency setting. Thus, a pulse train of desired repetition rate and pulse width can be set up. By using different duty cycle settings a variety of waveform possibilities are realized (Figure 3-7). Triggering may also be done manually or by programming.

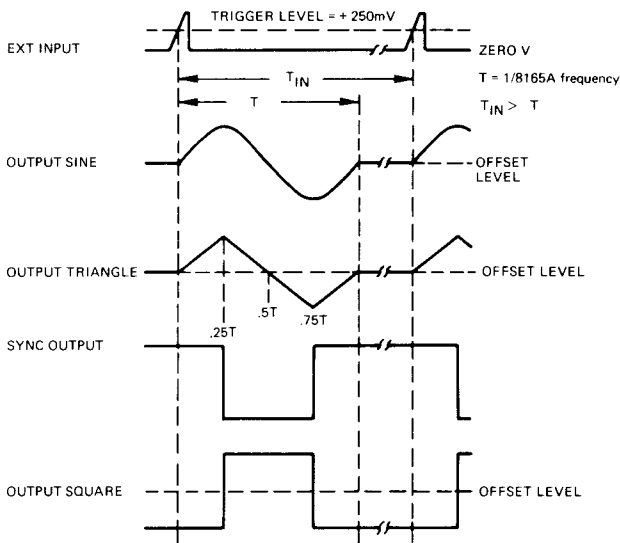

Figure 3-6 External Trigger Mode (50 % duty cycle/symmetry)

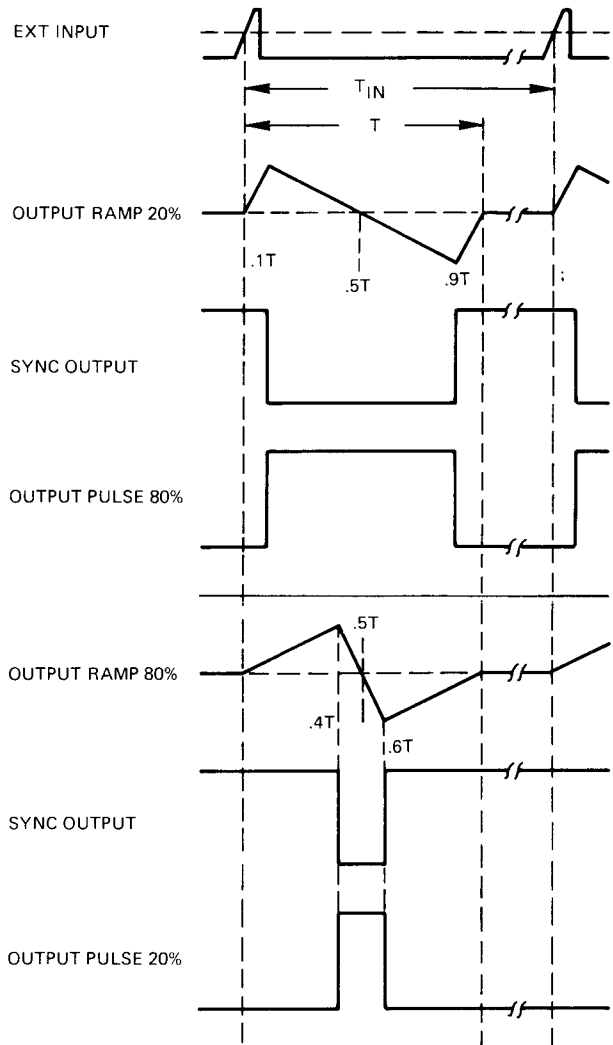

Figure 3-7. External Trigger Mode (20 and 80% duty cycle/symmetry)

3-22 Gate Mode (GATE)

3-23 In gate mode, the leading edge of a positive pulse applied to the EXT INPUT connector initiates the output stream, and the trailing edge causes the following

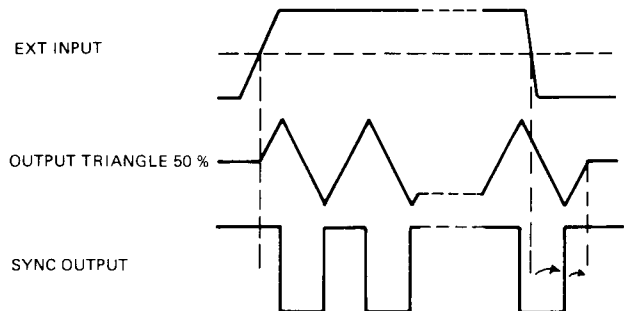

Figure 3-8. Example of Gate Mode

positive edge of the SYNC OUTPUT to terminate the stream at the next crossover. A whole number of complete output pulses are always generated.

3-24 Burst Mode (BURST)

3-25 A preset number of output cycles can be generated on each leading edge of a positive-going trigger pulse signal applied to EXT INPUT when burst mode is selected. The burst length may be set up to 9999 cycles as described in §3-50. At least 50 ns must separate consecutive bursts. Can be triggered manually.

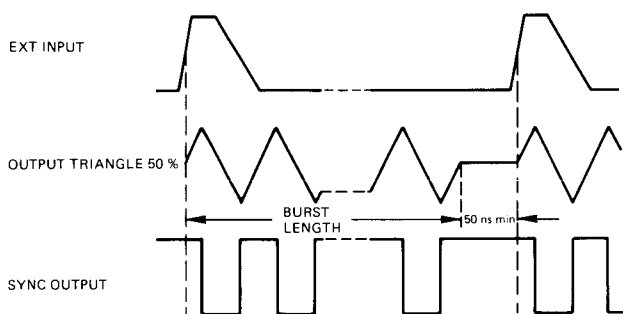

Figure 3-9. Example of Burst Mode

3-26 Sweep Modes – OPTION 002 Only

3-27 Internal Trigger Sweep selection will cause the output frequency to make one up/down sweep from the SWEEP START to the SWEEP STOP limits set on the 8165A (§3-48). As shown in Table 3-2, the sweep takes place within a band whose top decade brackets the SWEEP STOP value. The internally-generated, triangular, sweep voltage V_{sweep} is available at the rear panel SWEEP OUT BNC. Frequency change rate is logarithmic.

Table 3-2. Bands in Sweep Mode

SWEEP START min		SWEEP STOP max	
f_{out}	V_{sweep}	f_{out}	V_{sweep}
1 mHz	2.0 V	9.9 mHz	2.99 V
1 mHz	1.0 V	99 mHz	2.99 V
1 mHz	0.0 V	.99 Hz	2.99 V
10 mHz	0.0 V	9.9 Hz	2.99 V
.10 Hz	0.0 V	99 Hz	2.99 V
10 Hz	1.0 V	.99 kHz	2.99 V
10 Hz	0.0 V	9.9 kHz	2.99 V
.10 kHz	0.0 V	99 kHz	2.99 V
1 kHz	0.0 V	.99 MHz	2.99 V
100 kHz	1.0 V	9.9 MHz	2.99 V
500 kHz	0.69 V	50 MHz	2.69 V

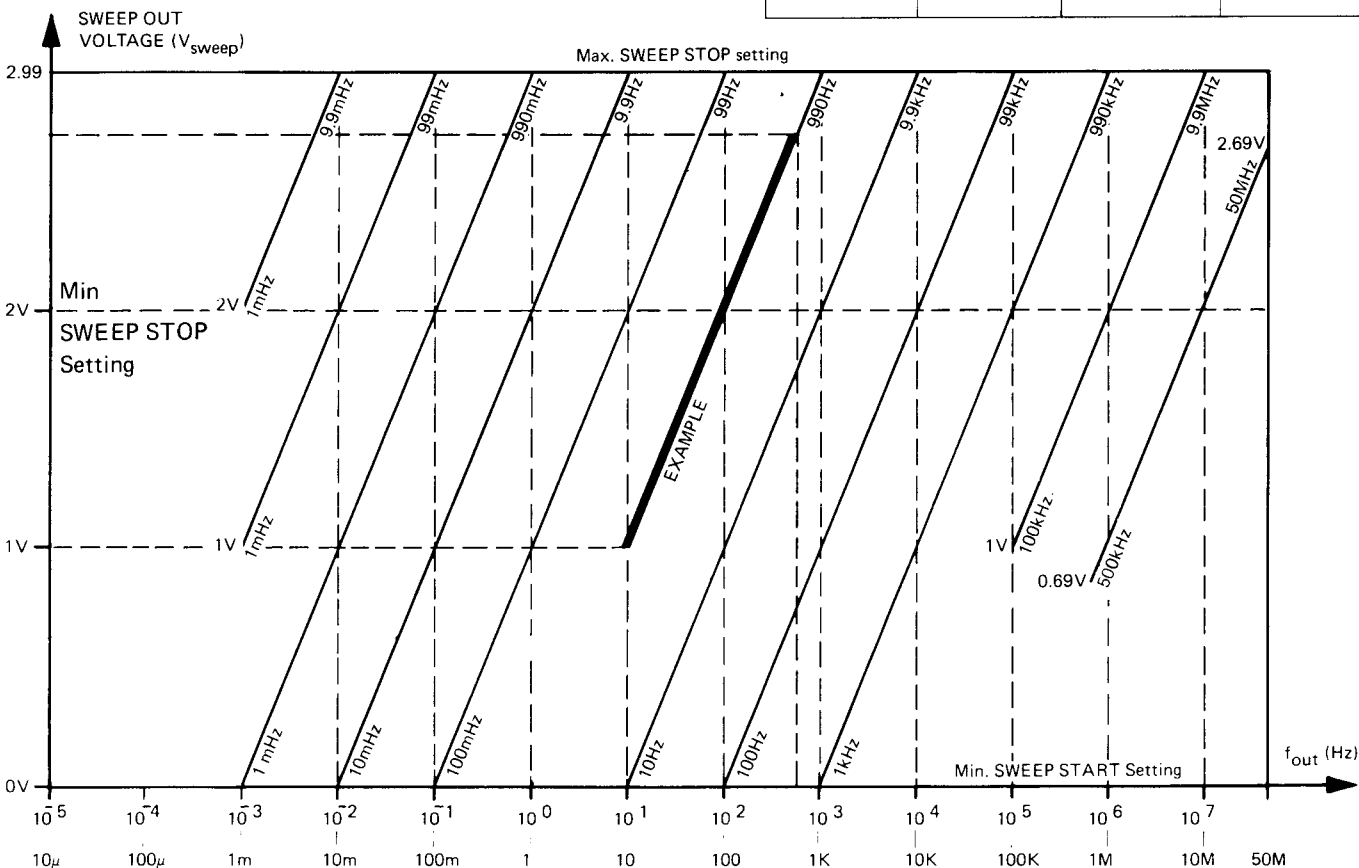

Figure 3-10. Sweep Mode Characteristics

3-28 As an example, suppose a sweep is required from 10 Hz (SWEEP START) to 700 Hz (SWEEP STOP), then V sweep varies between the levels 1.00 V (i.e., log 10) and 2.84 V (i.e., log 700).

3-29 Sweep times of 0.01, 0.1, 1, 10, 100, 1000 seconds per decade can be selected on the SWEEP TIME push-buttons.

3-30 **External Trigger Sweep** requires the application of a positive pulse at the EXT INPUT connector to initiate a single up/down sweep (Figure 3-11). In other respects, operation is the same as internal trigger sweep.

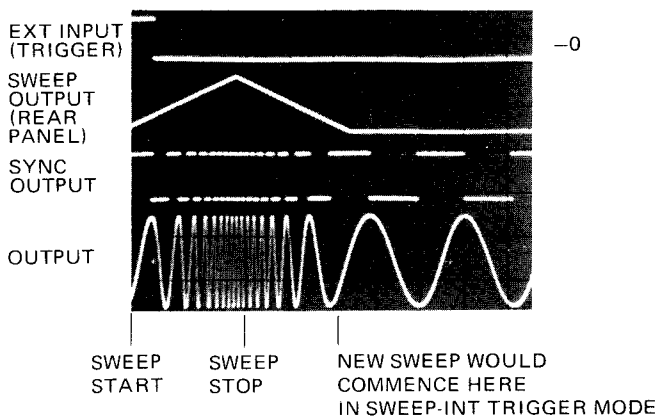

Figure 3-11. Example of Sweep Mode

3-31 Frequency Modulation (FM)

3-32 The 8165A's output can be frequency modulated by applying a voltage to the rear panel MOD INP connector. The maximum deviation is $\pm 1\%$ of carrier frequency for which an external voltage of ± 1 V is needed. In normal mode, the modulating voltage can vary in the range 100 Hz to 20 kHz. In trigger, gate or burst modes, the modulating frequency may be extended down to dc, but the 8165A's (carrier) frequency must be set to at least 1.000 kHz.

3-33 Amplitude Modulation (AM)

3-34 A signal can be applied to the rear panel MOD INP connector to provide a precisely amplitude-modulated signal at the 8165A output. Amplitude range for the modulating signal is 0–2.5 V_{pp} to provide a modulation range of 0–100%. Modulating frequency is dc to 10 kHz (–3 dB points).

3-35 Frequency Reference

3-36 Phase lock techniques, using an internal, precision 10 MHz crystal reference, achieve very stable output frequencies.

3-37 Frequency Generation

3-38 Because of the 8165A's wide frequency range, two methods of frequency generation are used. These lead to different distortion and stability considerations – but first, a brief description of the two methods.

3-39 The heart of the 8165A is a voltage-controlled, 1 kHz–50 MHz, oscillator which usually operates in phase lock using, as already mentioned, a crystal reference. For frequencies below 1 kHz, the output of the voltage-controlled oscillator is arranged to be an exact multiple of the required frequency, and a programmed divider reduces it to that needed. A triangular waveform is approximated by means of an up/down counter (programmed for 20, 50, or 80% duty cycle) and a D/A converter. (Sinewave is derived from the 50% duty cycle triangle using the same sine shaper as is used for frequencies above 1 kHz; square wave is derived by detecting the highest and lowest count of the up/down counter.) The D/A converter output consists of 1000 amplitude steps per output cycle; this means that, at 1 mHz for example, the amplitude changes from one discrete level to the next every second.

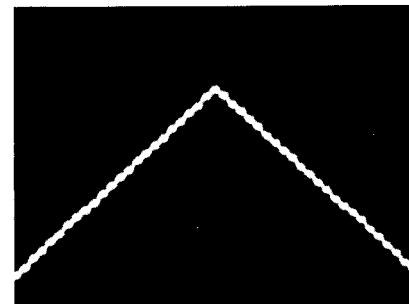

10 ms/div, 10 mV/div
8165A: 50Hz, triangle, 1 V.

Figure 3-12. Example of Triangle Output below 1 kHz

3-40 Differences in operation can now be summarized as follows:

- frequencies below 1 kHz
 - amplitude steps through 1000 discrete levels per cycle,
 - phase lock in all modes,
- frequencies above 1 kHz
 - amplitude continuous,
 - phase lock in normal mode only.

3-41 Output Parameters

3-42 The 8165A is designed so that source/load configurations of 50Ω into 50Ω , 50Ω into high impedance, and 1 k Ω into 50Ω can be easily arranged.

Amplitude and offset are independently variable and depend upon the source/load configuration (Table 3-3). As shown in Figure 3-13, reflections are minimized when the system is terminated by a low-capacitance 50Ω-load at the device which the 8165A drives. However, termination at the 8165A may be preferred if the device impedance is reactive.

20 V AMPLITUDE CAPABILITY
 OUTPUT MODE 50Ω, LOAD IMPEDANCE 1KΩ

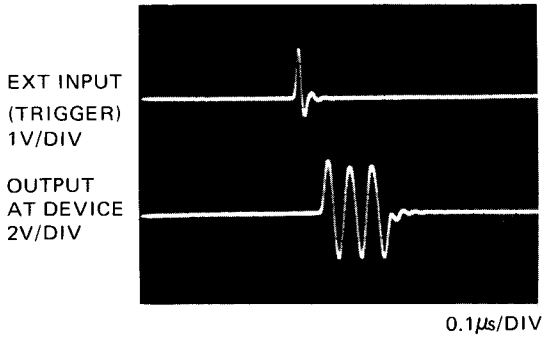

20 V AMPLITUDE CAPABILITY
 OUTPUT MODE 1KΩ, LOAD IMPEDANCE 50Ω

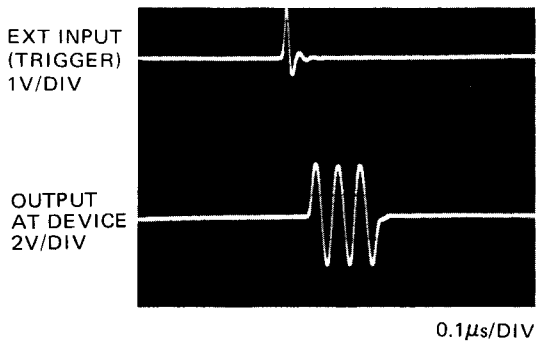

10 V AMPLITUDE CAPABILITY
 OUTPUT MODE 50Ω, LOAD IMPEDANCE 50Ω

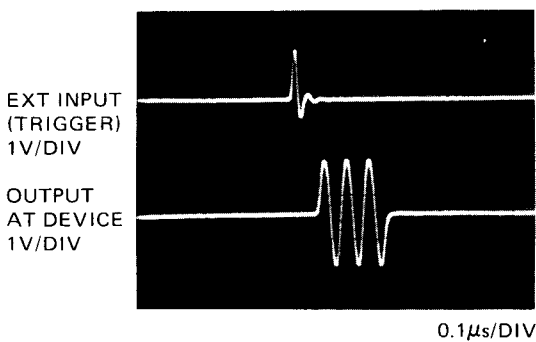

8165A SETTINGS: SINE, BURST (3 CYCLES), 20 MHz,
 AMPLITUDE 2.5V (DIGITAL DISPLAY), ZERO OFFSET

Figure 3-13. Source/load configurations (Low-capacitance load)

Table 3-3 Output Voltage Summary

OUTPUT MODE	EXT LOAD	AMPLITUDE ¹ V _{pp}		OFFSET ¹ V _{dc}		VOLTAGE AT EXT LOAD V _{pp} /V _{dc}
		MIN	MAX	MIN	MAX	
50Ω ²	50Ω	10mV	10V	0±10mV	±5V	As digital display
50Ω ²	HIGH Z	20mV	20V	0±20mV	±10V	Approx 2x digital display
1kΩ ³	50Ω	2V	20V	0±20mV	±10V	As digital display

Notes

1. Amplitude + offset must lie within a ± 10 V window. Voltages set as in §3-52.
 2. Applies only to displayed amplitudes ≤ 10V_{pp}
 3. Applies only to displayed amplitudes ≥ 2V_{pp}
- Attempts to select incompatible impedance/voltage configurations will not be accepted and will cause the ERROR lamp to light.

3-43 In addition to 50 Ω systems, the instrument is also suitable for driving any desired impedance. This is due to the current mode output configuration (Figure 3-14) where the maximum current available with 1 kΩ source impedance is ± 200mA peak signal and ± 200mA offset.

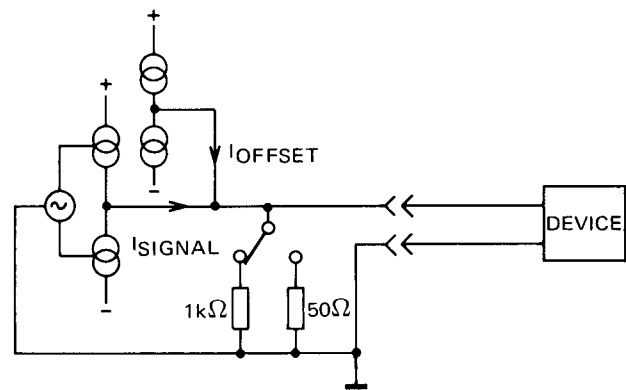

Figure 3-14. Configuration of Output Stage

3-44 The output can be turned on and off with the DISABLE/ENABLE button and may be inverted using the INV/NORM button. The OUTPUT MODE buttons are respectively lit when disable, invert and 1 kΩ are effective. Disable is automatic at switch-on. For threshold testing, the offset can be obtained without signal by selecting trigger, gate or burst modes in the absence of a trigger signal.

3-45 Selection and Storage of Parameters

3-46 Frequency

- 3-47 The 8165A's frequency is set as follows:
- press FRQ key, check that FREQUENCY lamp blinks,
 - press the required DATA keys sequentially (e.g., 4 then 3, then 2, then . , then 6) and observe that the display above the FREQUENCY lamp displays the desired number,
 - press the appropriate ENTRY key for the unit desired (e.g., "Hz or V") verify that the correct unit appears to the right of the FREQUENCY display and that the lamp glows steadily. The 8165A is now operating at the new frequency (432.6 Hz, in this example).

Use may be made of the VERNIER controls as follows:

- press FRQ key,
- press the appropriate VERNIER key for fast or slow, up or down shift. The output frequency changes with the display during this process so that it is only necessary to press an ENTRY key if the unit is to be changed.

When setting frequency for the VCO mode, refer to Table 3-1.

3-48 Sweep Start/Stop (Option 002 only)

- 3-49 When sweep mode is required, set the start and stop frequencies using procedures similar to §3-45 in conjunction with the SWEEP START and SWEEP STOP keys. Refer to Table 3-2 for the permissible bands.

3-50 Burst

- 3-51 The number of cycles per burst is set as follows:
- press PARAMETER key BURST, check that BURST lamp blinks,
 - press the desired DATA keys, check that the required number shows in the display above the BURST lamp,
 - press the ENTRY key "kHz or BURST".

3-52 Amplitude and Offset

- 3-53 Amplitude and offset are each set in a manner similar to frequency, using the AMPL and OFFSET keys.

If a negative offset is required, press the CHS (change sign) key any time during DATA entry but before pressing the mV or V key.

3-54 Storage and Recall

- 3-55 Ten addressable store locations are available, each of which is capable of storing a complete set of 8165A operating modes and parameters. To store a current set of modes and parameters:

- press STO (store) key,
- press a DATA key (0 to 9, as desired).

To put the 8165A into a previously-stored set of operating modes and parameters:

- press RCL (recall) key
- press the required DATA key (0 to 9).

3-56 Power-fail Memory

- 3-57 When power is removed from the 8165A, the current operating parameters are automatically stored in the power-fail memory so that, when the supply is restored, the 8165A can return to its previous operating state. However, to protect external circuits and prevent possible remote control ambiguities:

- the output is disabled,
- local control is implemented.

Consequently, deliberate (manual or programmed) intervention is required to obtain an output or to acquire remote control.

3-58 Storage and Access Times

- 3-59 Addressable memories and the power-fail memory remain effective for approx 4 weeks at room temperature after power has been removed. Access time is 20ms, see Table 1-2 for settling times.

Note: If the internal batteries are allowed to run down, data must be re-entered and the instrument should be left switched on so that the batteries can recharge.

3-60 Error Indication

- 3-61 If it is attempted to select incompatible operating modes or parameters, the ERROR lamp will flash and the 8165A will remain in its previous operating state. To clear an error, correct DATA and ENTRY. Common causes of errors are:

- frequency out of range,
- duty cycle/frequency,
- output impedance/voltage (see §3-41).

3-62 PROGRAMMING INSTRUCTIONS

3-63 The 8165A operates on the HP-IB as follows:
listens to messages from the HP-IB system controller by means of which all* 8165A operating parameters and modes can be programmed; access time (the time between program command and the implementation at the 8165A output, refer also to specifications, Table 1-2) is 20 ms, **vernier operation is simulated by programming a loop which increments/decrements a value.*
talks; provides error messages and reports operating state.

3-64 The bus lines are as follows (all use negative logic):
8-bit data bus (lines DIO 1 to 8),
handshake lines — DAV (data valid), NRFD (not ready for data), NDAC (data not accepted),
control lines — IFC (interface clear), ATN (attention), SRQ (service request), REN (remote enable), EOI (end or identify).

The 8165A uses all lines except EOI. Terminations, logic levels and pinouts are described in Section II. In this manual, bus information will generally be restricted to 8165A specifics, for this reason, the handshake lines will not be discussed and the control lines will only be mentioned in connection with specific 8165A activity.
 Permissible codes are presented in Table 3-8. For more bus information, refer to the condensed description in HP publication 59401-90030 and to IEEE Standard 488.

3-65 To use the 8165A on the bus, remote control must be implemented. This is done by setting the REN line true. A return to local control can be made manually (LOCAL RESET button), by sending the command GTL (go to local), or by setting REN false. Refer to §3-73.

3-66 Addressing

3-67 Talk and listen addresses are transmitted by the system controller over the data bus with the ATN line true. When an instrument recognizes its address, it will adopt the appropriate bus mode (i.e., it will listen to the bus if its listen address has been transmitted, talk if the talk address has been transmitted). The 8165A's addresses are selected by a switch on the rear panel from the possibilities presented in Table 3-4. When allocating addresses, make sure no two instruments have the same address.

When programming an address, set ATN true and arrange that the ASCII character derived from Table 3-4 appears on the bus. To deaddress, use UNL, UNT commands (or address another device as talker).

Table 3-4 Available Addresses (ATN true)

Data bus (DIO lines)		Address in ASCII		
Fixed	Selectable	Talk	Listen	
8 7 6	5 4 3 2 1			
0 T L	0 0 0 0 0	@	Space	
0 T L	0 0 0 0 1	A	!	
0 T L	0 0 0 1 0	B	"	
0 T L	0 0 0 1 1	C	#	
0 T L	0 0 1 0 0	D	\$	
0 T L	0 0 1 0 1	E	%	
0 T L	0 0 1 1 0	F	&	
0 T L	0 0 1 1 1	G	'	
0 T L	0 1 0 0 0	H	(
0 T L	0 1 0 0 1	I)	
0 T L	0 1 0 1 0	J	*	
0 T L	0 1 0 1 1	K	+	
0 T L	0 1 1 0 0	L	,	
0 T L	0 1 1 0 1	M	-	
0 T L	0 1 1 1 0	N	.	
0 T L	0 1 1 1 1	O	/	
0 T L	1 0 0 0 0	P	0	8165A set to this address at factory.
0 T L	1 0 0 0 1	Q	1	
0 T L	1 0 0 1 0	R	2	
0 T L	1 0 0 1 1	S	3	
0 T L	1 0 1 0 0	T	4	
0 T L	1 0 1 0 1	U	5	Usually controller address!
0 T L	1 0 1 1 0	V	6	
0 T L	1 0 1 1 1	W	7	
0 T L	1 1 0 0 0	X	8	
0 T L	1 1 0 0 1	Y	9	
0 T L	1 1 0 1 0	Z	:	
0 T L	1 1 0 1 1	[;	
0 T L	1 1 1 0 0	\	<	
0 T L	1 1 1 0 1]	=	
0 T L	1 1 1 1 0	^	>	
0 T L	1 1 1 1 1	—	?	Forbidden setting! UNT, UNL commands.

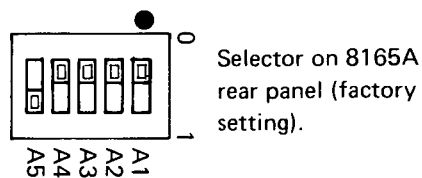

L = 1 for listen address, 0 for talk address
 T = 1 for talk address, 0 for listen address

3-68 Mode and Parameter Setting

3-69 When the 8165A has been listen-addressed, it will be prepared to accept messages which will change a parameter or its operating mode. Each mode and parameter-setting message consists of a number of ASCII data bytes transmitted serially over the data lines with

ATN false. The coding for the bytes is given on the front panel and also shown in Table 3-5 which summarizes all mode and parameter-setting messages, and provides an example. Reference may be made to Table 3-8 to convert each ASCII byte to a bit pattern on the data bus.

Table 3-5 Mode and Parameter-setting Messages (ATN false)

Message	Serial ASCII bytes	Comments
Function		
select sine	F1	
select triangle	F2	
select square	F3	
Duty cycle:		
select 20%	D1	See §3-76
select 50%	D2	
select 80%	D3	
Input mode:		
select normal	I1	
select VCO	I2	
select trigger	I3	Trigger message (Table 3-6) can be used.
select gate	I4	
select burst	I5	Trigger message (Table 3-6) can be used.
select ext trig sweep	I6	Option 002 only.
select int trig sweep	I7	Option 002 only.
Modulation:		
select FM	FM1	
reject FM	FM ϕ	
select AM	AM1	} AM Option 002 only
reject AM	AM ϕ	
Parameters:		
set frequency to <i>f</i> mHz	FRQfMZ	<i>f</i> a number 1-9999
set frequency to <i>f</i> Hz	FRQfHZ	<i>f</i> a number 0.001-9999
set frequency to <i>f</i> kHz	FRQfKHZ	<i>f</i> a number 0.001-9999
set frequency to <i>f</i> MHz	FRQfMHZ	<i>f</i> a number 0.001-50 (50% duty cycle), 0.001-19.99 (20,80%).
set amplitude to <i>v</i> mV	AMPvMV	<i>v</i> a number 10/20-999
set amplitude to <i>v</i> V	AMPvV	<i>v</i> a number 0.01 = 10/20
set offset to <i>v</i> mV *	OFSvMV	<i>v</i> a number $\pm 10/20 - \pm 5/10$
set offset to <i>v</i> V *	OFSvV	<i>v</i> a number $\pm 0.01 - \pm 5/10$
<i>*If no sign is given, the previous sign is assumed.</i>		} see §3-42.
set burst to <i>n</i> cycles	BURnBT	<i>n</i> an integer 0-9999
set sweep start to <i>f</i> mHz	STAfMZ	} Option 002 only, for <i>f</i> refer to §3-26.
set sweep start to <i>f</i> Hz	STAfHZ	
set sweep start to <i>f</i> kHz	STAfKHZ	
set sweep start to <i>f</i> MHz	STAfMHZ	
set sweep stop to <i>f</i> mHz	STPfMZ	
set sweep stop to <i>f</i> Hz	STPfHZ	
set sweep stop to <i>f</i> kHz	STPfKHZ	
set sweep stop to <i>f</i> MHz	STPfMHZ	

Table 3-5 (cont'd)

Message	Serial ASCII bytes	Comments
Sweep time: select 0.01s/decade select 0.1s/decade select 1 s/decade select 10s/decade select 100 s/decade select 1000s/decade	S1 S2 S3 S4 S5 S6	} Option 002 only
Output mode: disable output enable output invert input normal output select 1 kΩ output impeded. select 50 Ω output impeded.	OD OE OI ON O1 O5	
Memory: store current operating modes and parameters in 8165A store location n adopt parameters in store location n	STOn RCLn	} n an integer 0-9, see § 3-54

Example: a serial byte transmission

F2 D1 I4 FRQ99.9MZ AMP1.3V OFS-20MV OE OI O5 STO2

sets a listen-addressed 8165A to the following parameters: triangle, 20% duty cycle, gate mode, 99.9mHz, 1.3V amplitude, -20mV offset, output enabled, output inverted, 50 Ω output impedance. This entire set of parameters is then stored in the 8165A's memory location 2.

Example using Model 9825A Desktop Computer:

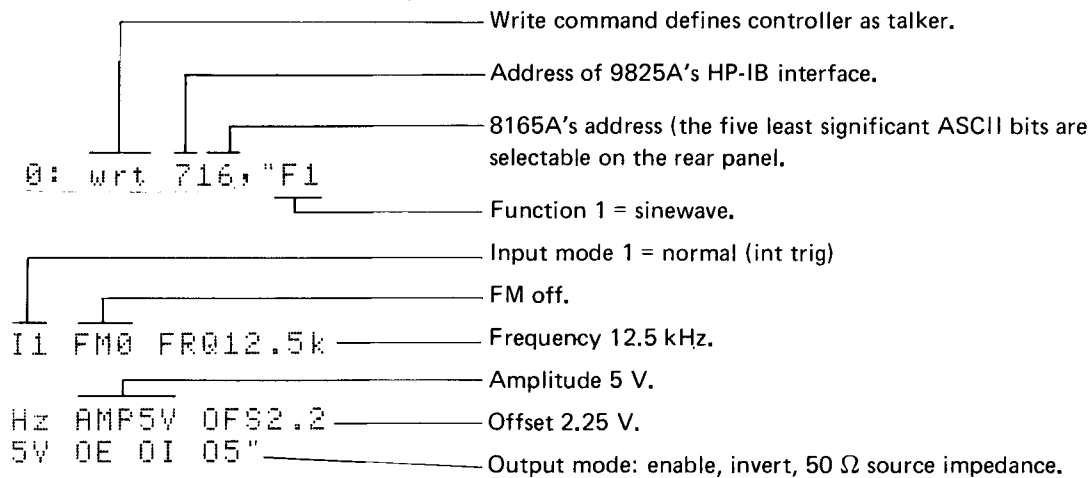

Notes

- Lower-case (small) letters may replace any or all of the ASCII capitals.
- Separators (i.e. space or comma) should be inserted between messages as shown in the above example
- In sweep mode, a separator must be inserted after a 'set sweep start' or 'set sweep stop' message.
- Omission of a separator may cause malfunction in error reporting (§ 3-77).
- The order in which parameters are programmed is not significant.

3-70 Control Messages and Commands (Table 3-6)

3-71 Programmed trigger

3-72 When the 8165A is in trigger or burst modes, a trigger message (GET) will initiate a single cycle or a burst. Example using HP 9825A Desktop Computer: trg 716.

3-73 Local, Remote and Local Lockout

3-74 When in remote, the 8165A's LOCAL RESET button can be inhibited by the local lockout command. To cancel local lockout, send GTL (go to local) or set the REN line false (or, the 8165A may be switched off, and on again at the LINE switch). The 9825A's GTL command is programmed by: lcl 7.

3-75 Learn Mode

3-76 When the 8165A is addressed as a talker subsequent to receiving the message 'SET':, the 8165A will output its current operating parameters to the bus (same coding as in Table 3-5). The message 'SETn' accesses addressable memory n. In neither case are the store contents changed in any way. The parameters are transmitted in 8 strings, as follows:

- String 1 — function, duty cycle, input mode, FM status, AM status.
 - String 2 — sweep time, output status, output norm/comp, output 50 Ω/1 kΩ.
 - String 3 — frequency.
 - String 4 — amplitude.
 - String 5 — offset.
 - String 6 — burst.
 - String 7 — sweep start
 - String 8 — sweep stop
- } Standard 8165A transmits CR/LF

Each string has up to 16 characters and is terminated by CR/LF. Note that, in pulse operation, the learn mode duty cycle message is changed. Use the following table to check the interpretation:

		Program (Listen)	Learn (Talk)
Duty cycle (Square/pulse)	20 %	D1	D3
	50 %	D2	D2
	80 %	D3	D1
Symmetry (Triangle/tramp)	20 %	D1	D1
	50 %	D2	D2
	80 %	D3	D3

Example using the HP 9825A Desktop Computer:

```
0: dim A$(0,20) — Array dimensioned.
1: wrt 716,"SET:" — Request for current parameters.
2: read 716,A$(1) — Talk address. 9825A reads first string.
3: end
*2742
```

F1 D2 I6 FM0 AM0 -9825A prints first string.

Step 2 is repeated for other strings (A\$ [x]) as required.

3-77 Error Reporting

3-78 In the event of a program attempting to put the 8165A into an error condition, the 8165A will remain in its previous operating condition and make a service request (sets SRQ line true). Under these circumstances, when addressed as a talker for purposes of a serial poll (i.e. SPE command sent from system controller), the 8165A puts an error message on the data bus. This message consists of a single byte in which bit 7 is set true when the 8165A has set the SRQ line true, and bits 1 to 4 comprise an error code (Table 3-7). See step 6 of Figure 3-16 overleaf.

Table 3-7. Error Messages

Data bus DIO lines	Message
8 7 6 5 4 3 2 1	
0 1 0 0 1 0 0 0	Amplitude out of range
0 1 0 0 1 0 0 1	Offset out of range
0 1 0 0 1 0 1 0	Frequency out of range
0 1 0 0 1 0 1 1	Output impedance error
0 1 0 0 1 1 0 0	Duty cycle/frequency incompatible
0 1 0 0 1 1 0 1	Sweep start/stop incompatible
0 1 0 0 1 1 1 0	Sweep out of range
0 1 0 0 1 1 1 1	Syntax error

Table 3–6. Control Messages and Commands

Message/Command	8165A Status	Bus data (ASCII)	9825A program example	Comments
Remote control	Local Listen/talk	Listen/talk address	rem 716	REN line true
Go to local	Listen Local	[SOH] *	lcl 716	ATN line true
Local lockout (LLO)	Listen	[DC1] *	llo 7	ATN line true
Give current operating parameters	Listen Talk	SET: As Table 3–5	wrt 716, "SET:"	
Give parameter set in location <i>n</i>	Listen Talk	SET <i>n</i> As Table 3–5	wrt 716, "SET <i>n</i> "	<i>n</i> is an integer 0–9
Trigger (GET)	Listen	[BS] *	trg.716	
Serial poll (SPE)	Any Talk	[CAN] * Error message (Table 3–7)	rds 716	with SRQ true DIO 7 true if 8165A has set SRQ true.

[] * = Single ASCII character. Do *not* program the individual characters within the brackets.

3–79 Program Example

3–80 The flow chart in Figure 3–15 illustrates typical 8165A bus activity when used with a computing controller. An imaginary situation has been chosen in which sequential operation at ten harmonically-related frequencies is required, each frequency being active for a duration of one second. The frequencies (as, indeed, all other operating modes and parameters) are stored in the 8165A's memory, counter loops being employed to generate location address and frequencies. A programmed loop reads the 8165A status and prints a report in the event of an error.

3–81 A possible way of implementing the flow chart using the Model 9825A Desktop Computer with HP-IB

interface 98034A is shown in the program example of Figure 3–16. In this example, the 98034A's address is assumed to be 7, thus the address of an instrument on the HP-IB is 7XX where XX is the *decimal* equivalent of the five least significant bits of the bus address. As an 8165A address selector setting of 10000 (Table 3–4) is assumed, for which the decimal equivalent is 16, the 8165A's address for purposes of programming with the 9825A is 716. Talk or listen addresses (more specifically, bits 6 and 7 of the HP-IB address) are automatically specified by the kind of statement governing the 9825A's activity, e.g., the statement rds 716 tells the 9825A to read from the bus and tells the 8165A to talk (talk address 16, ASCII P); the statement wrt 716 tells the 9825A to output to the bus and tells the 8165A to listen (listen address 16, ASCII zero).

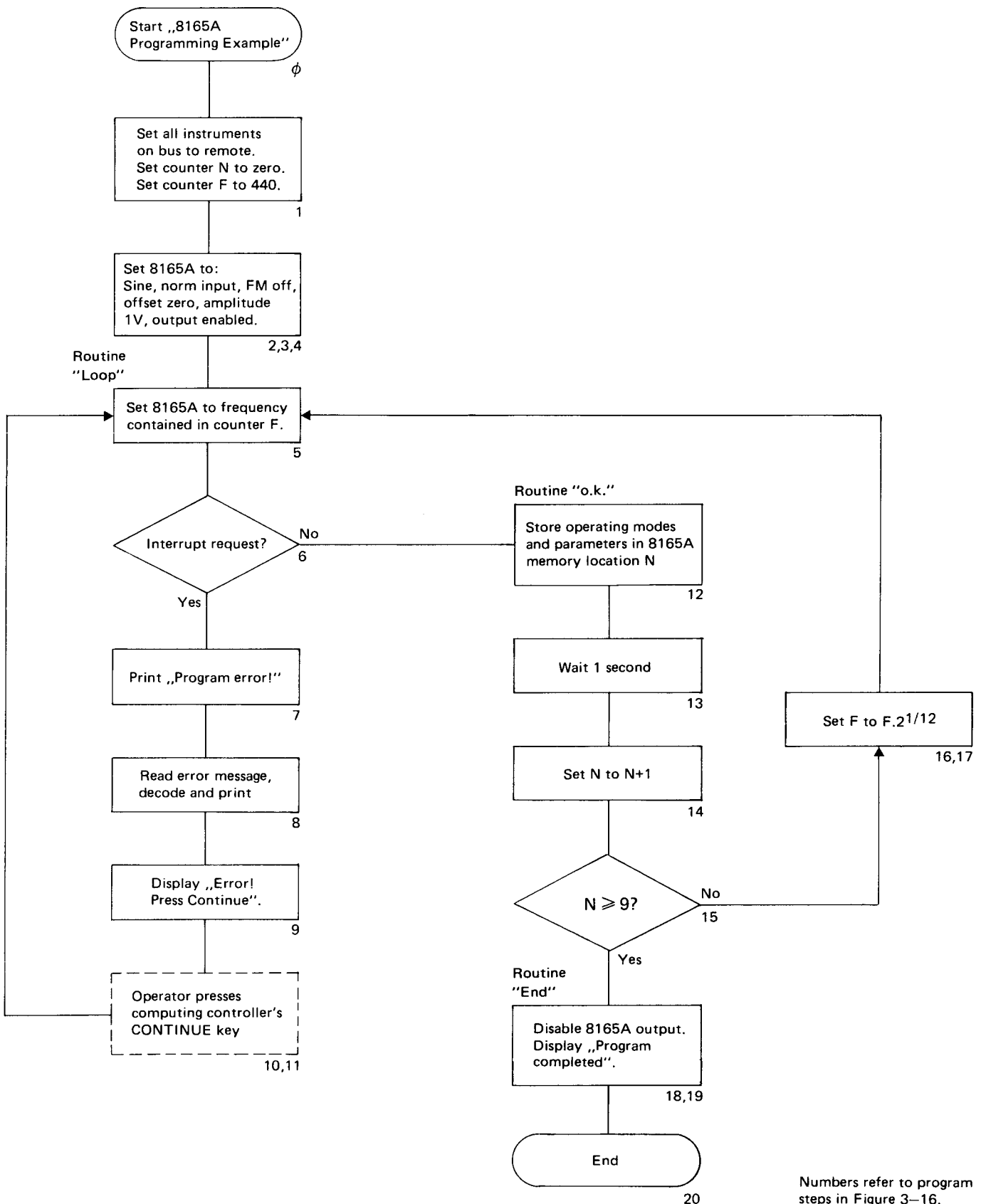

Numbers refer to program steps in Figure 3-16.

Figure 3-15. Illustrative Flow Chart

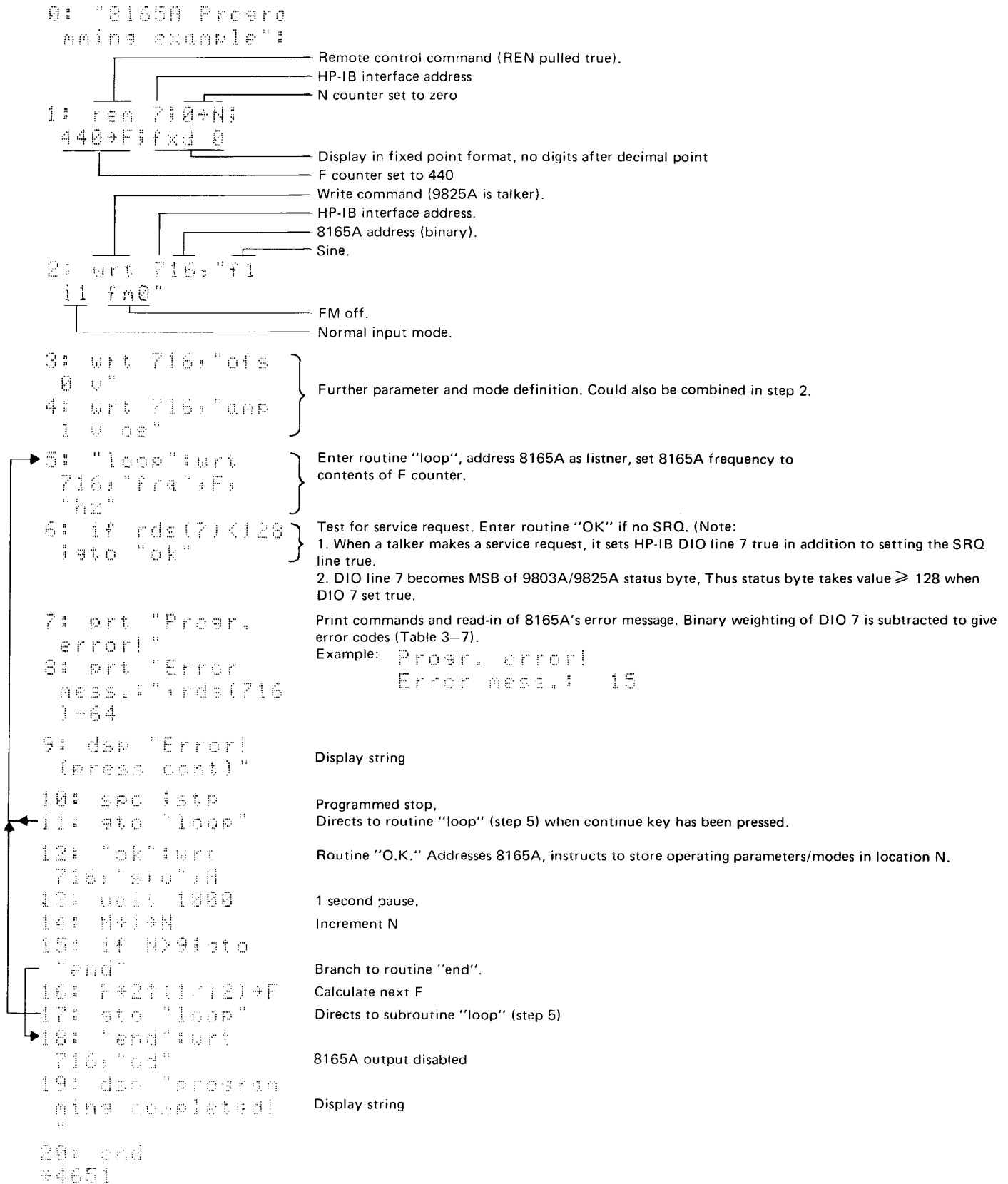

Figure 3-16. Program Example

Table 3-8. HP-IB Code Assignments (ASCII) for the 8165A

APPLIES ONLY IN COMMAND MODE (ATN TRUE)
 THESE CHARACTERS CAUSE SRQ
 THESE CHARACTERS ARE IGNORED

HP-IB DATA LINES					7	0	0	0	0	1	1	1	1		
4	3	2	1	0	0	0	0	1	1	0	0	1	1		
0	0	0	0	0	NUL										
0	0	0	1	1	SOH	GTL		LLO		0		␣	P		p
0	0	1	0	2	STX					1		A	Q		a
0	0	1	1	3	ETX					2		B	R		b
0	1	0	0	4	EOT					3		C	S		c
0	1	0	1	5	ENQ					4		D	T		d
0	1	1	0	6	ACK					5		E	U		e
0	1	1	1	7	BEL					6		F	V		f
1	0	0	0	8	BS	GET		SPE		7					
1	0	0	1	9	HT			SPD		8		H			h
1	0	1	0	10	LF					9		I			i
1	0	1	1	11	VT								Z		
1	1	0	0	12	FF							K			k
1	1	0	1	13	CR							L			l
1	1	1	0	14	SO							M			m
1	1	1	1	15	SI							N			n
												UNL	O		
															oo

↑ ASSIGNED LISTEN ADDRESS ↑ ASSIGN LISTEN ADDRESS ↓ ASSIGNED TALK ADDRESS ↓ ASSIGNED TALK ADDRESS

← SAME INTERPRETATION ← SAME INTERPRETATION

SECTION IV PERFORMANCE TESTS

4-1 INTRODUCTION

4-2 The procedures in this section test the electrical performance of the instrument using the specifications of Table 1-2 as performance standards. All tests can be performed without access to the interior of the instrument.

4-3 EQUIPMENT REQUIRED

4-4 Equipment required for the performance tests is listed in Table 1-1, Recommended Test Equipment. Any equipment that satisfies the critical specifications given in the table may be substituted for the recommended model(s).

4-5 TEST RECORD

4-6 Results of the performance tests may be tabulated on the Test Record at the end of the test procedures. The Test Record lists all of the tested specifications and their acceptable limits. Test results recorded at incoming

inspection can be used for comparison in periodic maintenance, troubleshooting, and after repairs or adjustments.

4-7 PERFORMANCE TESTS

4-8 The performance tests given in this section are suitable for incoming inspection, troubleshooting, or preventive maintenance. During any performance test, all shields and connecting hardware must be in place. The tests are designed to verify the published instrument specifications, perform the tests in the order given and record the data on the test card and/or in the data spaces provided at the end of each procedure.

4-9 Each test is arranged so that the specification is written as it appears in Table 1-2. Next, a description of the test and any special instructions or problem areas are included. Each test that requires test equipment has a setup drawing and a list of the required equipment. The initial steps of each procedure give control settings required for that particular test.

PERFORMANCE TESTS

4-10 FREQUENCY

SPECIFICATION

1.000 mHz to 50.00 MHz (1.000 mHz to 19.99 MHz for 20 % and 80 % duty cycle/symmetry).
 Accuracy in NORM input mode: 0.001 %.

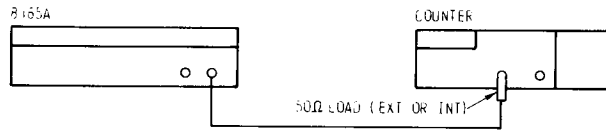

Figure 4-1. Test Setup for Frequency and Burst

EQUIPMENT

- Counter
- Cable Assembly BNC (61 cm)
- Feedthrough Termination 50 Ω (if necessary).

PROCEDURE

1. Connect equipment as shown in Figure 4-1
2. Set 8165A as follows:

INPUT MODE	NORM
FUNCTION	SQUARE
DUTY CYCLE	50%
FM	OFF
AMPL	1 V
OFFSET	0 V
OUTPUT MODE	ENABLE
	NORM
	50 Ω

3. Set counter to frequency measurement.
4. Set 8165A frequency and verify counter frequency reading as follows:

8165A setting	Counter reading
50.0 MHz	50.0000 MHz ± 500 Hz
10.0 MHz	10.0000 MHz ± 100 Hz
10.0 kHz	10.0000 kHz ± 0.1 Hz
1.00 kHz	1.00000 kHz ± 0.01 Hz

5. Set 8165A frequency and verify counter period reading as follows:

8165A setting	Counter reading
1.00 Hz	1.00000 s ± 10 μs
100 mHz	10.00000 s ± 100 μs

PERFORMANCE TESTS

4-11 BURST

SPECIFICATION

A pre-programmed number of output cycles is generated on receipt of an input trigger signal or manual command, min time between bursts: 50 ns. Burst length: 1 to 9999 cycles.

EQUIPMENT

- Counter
- Cable Assembly BNC (61 cm)
- Feedthrough Termination 50 Ω (if necessary).

PROCEDURE

1. Load Burst number 8165 into 8165A.
2. Set 8165A as follows:

INPUT MODE	BURST
FUNCTION	SQUARE
DUTY CYCLE	50 %
FM	OFF
FRQ	10 kHz
AMPL	1 V
OFFSET	0 V
BURST	8165
OUTPUT MODE	ENABLE
		NORM
		50 Ω

3. Use figure 4-1 test setup and set counter to START.
4. Press 8165A's MAN button and verify that counter now displays the set number (8165) of output cycles. (5345A reading will be 8164, since first pulse arms the counter).

PERFORMANCE TESTS

4-12 AMPLITUDE AND OFFSET

SPECIFICATION

Amplitude and offset independently variable within ± 10 V. Source impedance: selectable $50 \Omega \pm 1\%$ or $1 \text{ k}\Omega \pm 10\%$, in parallel with 50 pF .

Ranges: 10.0 mV_{pp} to 10.0 V_{pp} (50Ω into 50Ω) and 2.00 V_{pp} to 20.0 V_{pp} ($1 \text{ k}\Omega$ into 50Ω).

Accuracy	Sine V V _{rms}	Square	Triangle (50%)	Ramp 20%-80%	Pulse 20%-80%
< 1 kHz	+/- 3%	+/- 2%	+/- 3%	+/- 3%	+/- 2%
1 kHz - 4.99 MHz	+/- 3%	+/- 2%	+/- 3%	+/- 5%	+/- 2%
5 MHz - 19.9 MHz	+/- 8%	+/- 5%	+/- 10%	+/- 10%	+/- 5%
20 MHz - 50 MHz	+/- 8%	+/- 5%	+5% to -20%		

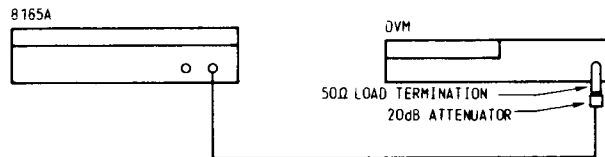

Figure 4-2. Test Setup for Amplitude and Offset.

EQUIPMENT

- Digital Voltmeter
- Cable Assembly BNC (1 x 61 cm)
- Feedthrough Termination 50Ω
- Power Attenuator 20 dB, 20 W

Total attenuation to be within $\pm 0.5\%$ of nominal.

PROCEDURE

1. Connect the equipment as shown in Figure 4-2.
2. Set 8165A as follows:

INPUT MODE	NORM
FUNCTION	SINE
DUTY CYCLE	50 %
FM	OFF
FRQ	10 kHz
OFFSET	0 V
OUTPUT MODE	ENABLE
	NORM
	1 k Ω

PERFORMANCE TESTS

3. Using best DVM resolution, measure the RMS voltages for the following 8165A settings:

OUTPUT MODE	AMPL	FUNCTION	DVM Reading
1 k Ω	20.0 V	Sine	0.686 V - 0.728 V
		triangle	0.560 V - 0.595 V
		square	0.980 V - 1.020 V
50 Ω	10.0 V	Sine	0.343 V - 0.364 V
		triangle	0.280 V - 0.297 V
		square	0.490 V - 0.510 V

4. Remove 20 dB attenuator and continue:

50 Ω	5.00 V	Sine	1.715 V - 1.821 V
		triangle	1.400 V - 1.487 V
		square	2.450 V - 2.550 V
50 Ω	3.00 V	Sine	1.029 V - 1.092 V
		triangle	0.840 V - 0.892 V
		square	1.470 V - 1.530 V
50 Ω	1.00 V	Sine	0.343 V - 0.364 V
		triangle	0.280 V - 0.297 V
		square	0.490 V - 0.510 V
50 Ω	100 mV	Sine	33.4 mV - 36.4 mV
		triangle	28.0 mV - 29.7 mV
		square	49.0 mV - 51.0 mV

5. Set 8165A to AMPL 10 mV SINE.

6. Using best DVM resolution, measure dc voltages for the following 8165A settings:

OUTPUT MODE	OFFSET	DVM Reading
50 Ohm	5.00 V	4.93 V - 5.070 V
50 Ohm	3.00 V	2.95 V - 3.050 V
50 Ohm	1.00 V	0.970 V - 1.030 V
50 Ohm	100 mV	79.9 mV - 121.1 mV

PERFORMANCE TESTS

4-13 SINE CHARACTERISTICS

SPECIFICATION

Harmonic Components: Up to 5 MHz, THD < 1% of fundamental. Above 5 MHz with amplitude greater than or equal to 100 mV, all harmonics at least 30 dB below fundamental.

Spurious: all non-harmonically related outputs at least 40 dB below fundamental.

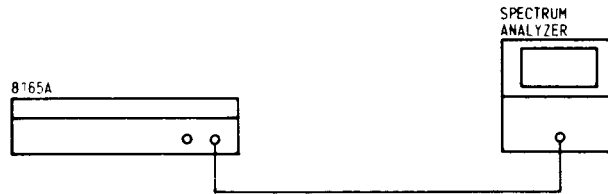

Figure 4-3. Test Setup for Sine Characteristics

EQUIPMENT

- Spectrum analyzer
- Cable assembly BNC (1 x 61 cm)

PROCEDURE

1. Connect the equipment as shown in Figure 4-3.
2. Set 8165A as follows:

INPUT MODE	NORM
FUNCTION	SINE
DUTY CYCLE	50 %
FM	OFF
FRQ	1 MHz
AMPL	1.99 V
OFFSET	0 V
OUTPUT MODE	ENABLE
		NORM
		50 Ω

3. Tune spectrum analyzer for minimum display amplitude. Adjust gain so that fundamental corresponds to 0 dB. Verify that the 2nd and 3rd harmonics do not exceed the - 42 and - 47 dB levels, respectively.

PERFORMANCE TESTS

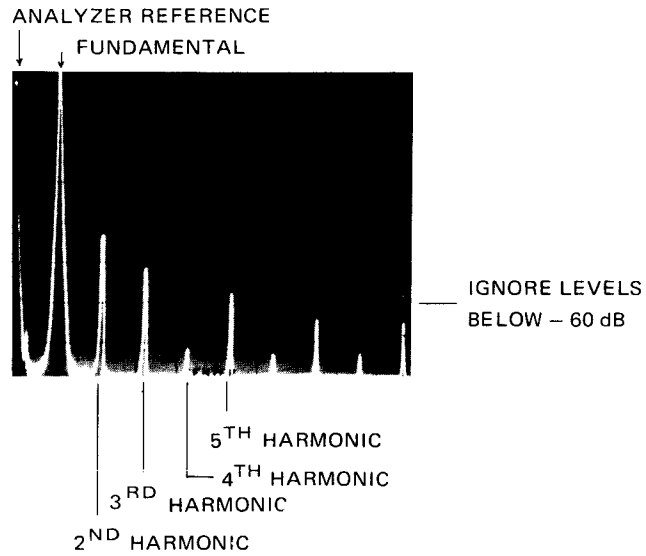

Figure 4-4. Typical Spectrum Analyzer Display at 1 MHz

4. Verify that THD < 1 %

$$THD = \frac{\sqrt{E_1^2 + E_2^2 + E_3^2 + \dots}}{E_0} \cdot 100 \%$$

where E_0 = fundamental voltage amplitude and E_1, E_2 etc are the 2nd, 3rd etc harmonic amplitudes.

When the harmonics are expressed in dB the formula becomes:

$$THD = \sqrt{10^{\frac{A_1}{10}} + 10^{\frac{A_2}{10}} + 10^{\frac{A_3}{10}} + \dots} \cdot 100 \%$$

where A_1 = first harmonic in dB etc.

5. Set 8165A FRQ to 50 MHz.
 6. Tune spectrum analyzer for minimum display amplitude. Adjust gain so that fundamental corresponds to 0 dB. Verify that no harmonics exceed the -30 dB level.

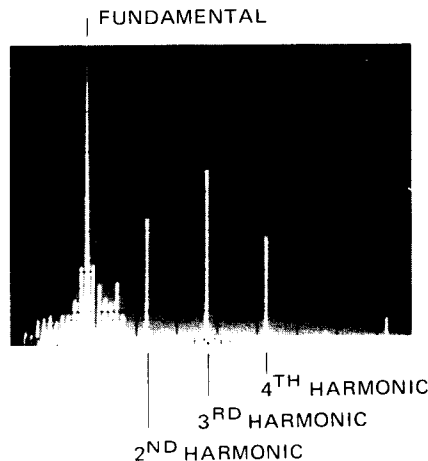

Figure 4-5. Typical Spectrum Analyzer Display at 50 MHz

PERFORMANCE TESTS

4-14 PULSE CHARACTERISTICS

SPECIFICATION

Transition times (10% to 90%): < 5 ns,
 < 7 ns (1 kΩ into 50 Ω).

Preshoot/Overshoot/Ringing: ± 5%,
 ±10% (1 kΩ into 50 Ω).

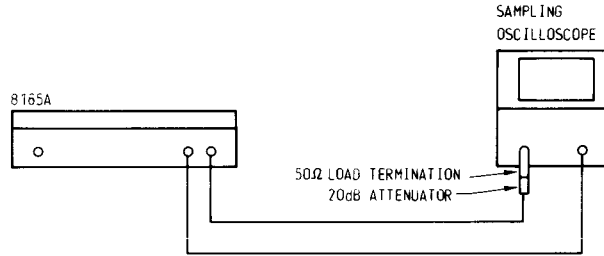

Figure 4-6. Test Setup for Pulse Characteristics.

EQUIPMENT

- Sampling oscilloscope
- Cable assembly BNC (2 x 61 cm)
- Feedthrough termination 50 Ω
- Power attenuator 20 dB, 20 W

PROCEDURE

1. Connect the equipment as shown in Figure 4-6.
2. Set the 8165A as follows:

INPUT MODE	NORM
FUNCTION	SQUARE
DUTY CYCLE	50 %
FM	OFF
FRQ	1 MHz
AMPL	1 V
OFFSET	0 V
OUTPUT MODE	ENABLE
		NORM
		50 Ω

3. Set scope so that one cycle fills the display (Figure 4-7).

- leading edge (risetime) ≤ 5 ns
- trailing edge (risetime) ≤ 5 ns
- preshoot ≤ ± 5 % of amplitude
- overshoot and ringing ≤ ± 5 % of amplitude

PERFORMANCE TESTS

4-15 RAMP CHARACTERISTICS

SPECIFICATION

Linearity (10 % to 90 %): $\pm 1\%$ (up to 5 MHz), $\pm 5\%$ (above 5 MHz)

EQUIPMENT

- Sampling oscilloscope
- Cable assembly BNC (2 x 61 cm)
- Feedthrough termination 50 Ω
- Power attenuator 20 dB, 20W

PROCEDURE

1. Connect the equipment as shown in Figure 4-6.
2. Set the 8165A as follows:

INPUT MODE	NORM
FUNCTION	TRIANGLE
DUTY CYCLE	50 %
FM	OFF
FRO	1 MHz
AMPL	1 V
OFFSET	0 V
OUTPUT MODE	ENABLE
	NORM
	50 Ω

3. Set scope so that one cycle fills the display.
4. Verify leading edge non-linearity (Figure 4-7) $< \pm 1\%$ of amplitude.
5. Set 8165A output mode to INV and verify that signal changes polarity.

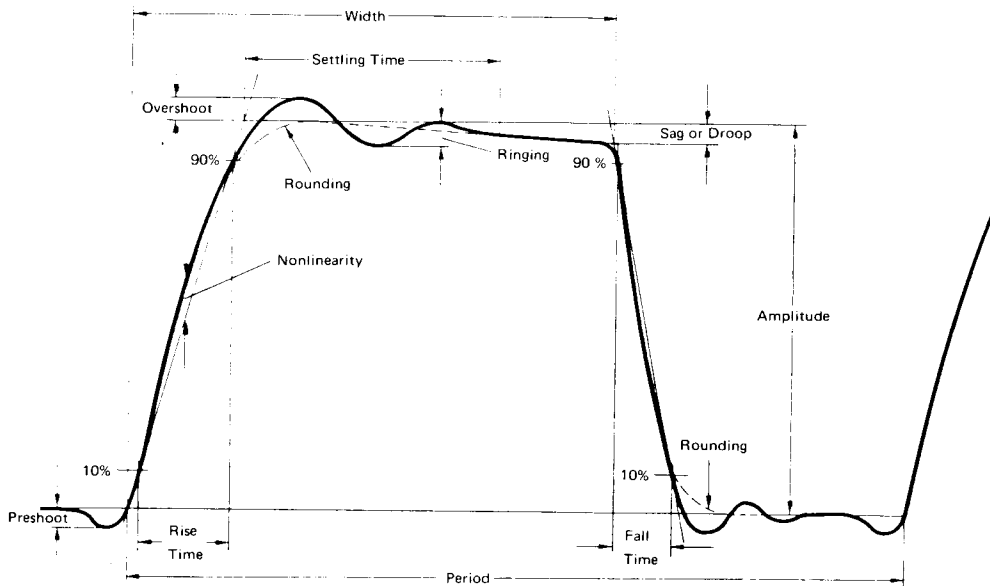

Figure 4-7. Pulse Parameters

PERFORMANCE TESTS

4-16 GATE AND TRIGGER PERFORMANCE

SPECIFICATION

Trig: pos. ext input pulse ≥ 10 ns wide generates one output cycle. Upper level $\geq +250$ mV, lower level ≤ 0 V.

Gate: oscillator enabled when ext input $\geq +250$ mV, disabled when ≤ 0 V. First and last output cycles are always complete.

Max input: ± 20 V

Input impedance: 10 k Ω typical

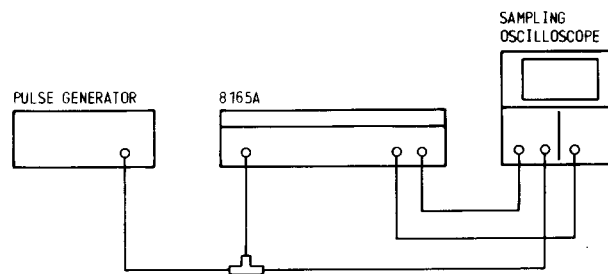

Figure 4-8. Test Setup for Burst Gate and Trigger Performance

EQUIPMENT

- Pulse generator
- Oscilloscope
- Cable assembly (3 x 61 cm, 2 x 30 cm)
- BNC Tee,
- Feedthrough termination 50 Ω

PROCEDURE

1. Connect the equipment as shown in Figure 4-8.
2. Set the 8165A as follows:

INPUT MODE	GATE
FUNCTION	SINE
DUTY CYCLE	50 %
FM	OFF
FRQ	100 kHz
AMPL	1 V
OFFSET	0 V
OUTPUT MODE	ENABLE
		NORM
		50 Ω

PERFORMANCE TESTS

- Set pulse generator for output pulse approx $50 \mu\text{s}$ wide, rep. rate 1 kHz, baseline zero or more negative, pulse top + 250 mV. Verify that each positive gate releases a burst of output cycles and that each cycle is complete (Figure 4–9).

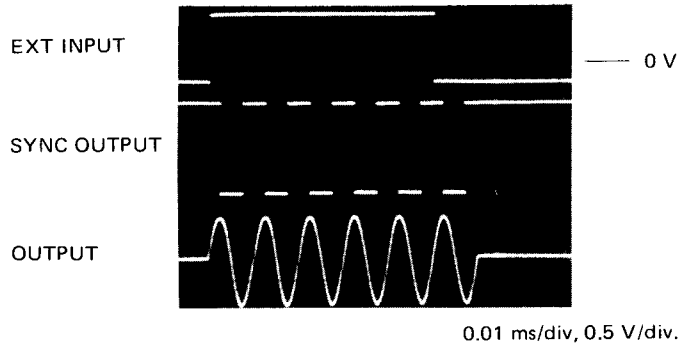

Figure 4–9. Example of correct gate operation

- Set 8165A to TRIG mode. Verify that each trigger pulse generator one complete output cycle (Figure 4–10).

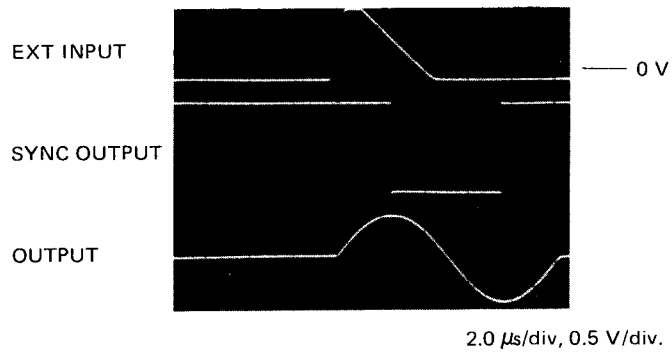

Figure 4–10. Example of correct trigger operation

PERFORMANCE TESTS

4-17 FM.

SPECIFICATION

Output is frequency modulated by an external voltage applied to a rear panel BNC, 0 to ± 1 V modulates 0 to ± 1 % deviation.

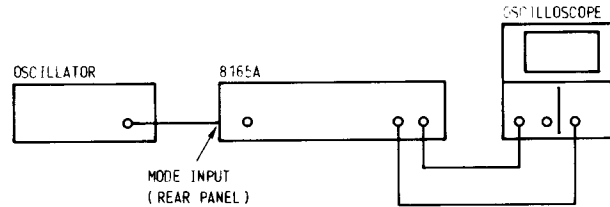

Figure 4-11. Test Setup for FM

EQUIPMENT

- Oscillator
- Oscilloscope
- Cable assembly BNC (3 x 61 cm)

PROCEDURE

1. Connect the equipment as shown in Figure 4-11.
2. Set oscillator to 10 kHz, 2 Vpp
3. Set oscilloscope to 1 μ s/div main timebase, 0.05 μ s/div delayed time base.
4. Set the 8165A as follows:

INPUT MODE	NORM
FUNCTION	SQUARE
DUTY CYCLE	50 %
FM	0 N
FRQ	1 MHz
AMPL	1 V
OFFSET	0 V
OUTPUT MODE	ENABLE
		NORM
		50 Ω

5. Check the delayed sweep for a jitter of 2 div ± 10 %.
6. Turn FM off, verify that the delayed sweep jitter ≤ 0.2 div.

PERFORMANCE TESTS

4-18 SWEEP (OPTION 002 ONLY)

SPECIFICATION

Provides logarithmic up/down sweep up to 3 decades between limits set on the 8165A.
As in VCO mode, 4 bands limited to less than 3 decades Min frequency 1 mHz.

Sweep-rate: 0.01, 0.1, 1, 10, 100, 1000 seconds per decade selectable.

Trigger: one up-down sweep per trigger pulse (upper level $\geq +250$ mV, lower level ≤ 0 V, width > 10 ns).

Accuracy: sweep start frequency: $\pm 15\%$ $\pm 0.5\%$ of max. stop frequency
sweep stop frequency: $\pm 15\%$

Resolution: 2 digits



Figure 4-12. Test Setup for Sweep Option 002

EQUIPMENT

Counter
Cable assembly BNC (1 x 61 cm)
Feedthrough termination $50\ \Omega$ (if necessary).

PROCEDURE

1. Connect the equipment as shown in Figure 4-12.

PERFORMANCE TESTS

2. Set the 8165A as follows:

INPUT MODE	SWEEP: INT TRIG
FUNCTION	SINE
DUTY CYCLE	50 %
FM	OFF
FRQ	1 kHz
AMPL	2 V
OFFSET	0 V
OUTPUT MODE	ENABLE
		NORM
		50 Ω
SWEEP START	10 kHz
SWEEP STOP	10 kHz
SWEEP TIME	1 s/decade

3. Verify counter reading for the following settings:

SWEEP START	SWEEP STOP	Counter reading
10 kHz	10 kHz	10 kHz +/- 6.5 kHz
1 MHz	1 MHz	1 MHz +/- 400 kHz
40 MHz	40 MHz	40 MHz +/- 6.25 MHz

PERFORMANCE TESTS

4-19 AMPLITUDE MODULATOR (Option 002 only)

SPECIFICATION

(Option 002 only): 0 to 2.5 V_{pp} modulates 0 to 100 % modulation depth.

Modulating Frequency: dc to 10 MHz (- 3 dB).

Input Impedance: 10 kΩ typical.

Pulse Modulation: transition times < 50 ns.

Envelope Distortion: (dc to 250 kHz mod. freq.):

Carrier	Modulation	Distortion
≤ 1 MHz	0 to 90 %	< 1 %
> 1 MHz	0 to 30 %	< 3 %

Carrier Frequency Deviation: < 0.01 %, 0 to 30 % modulation.

EQUIPMENT

- Oscillator
- Oscilloscope

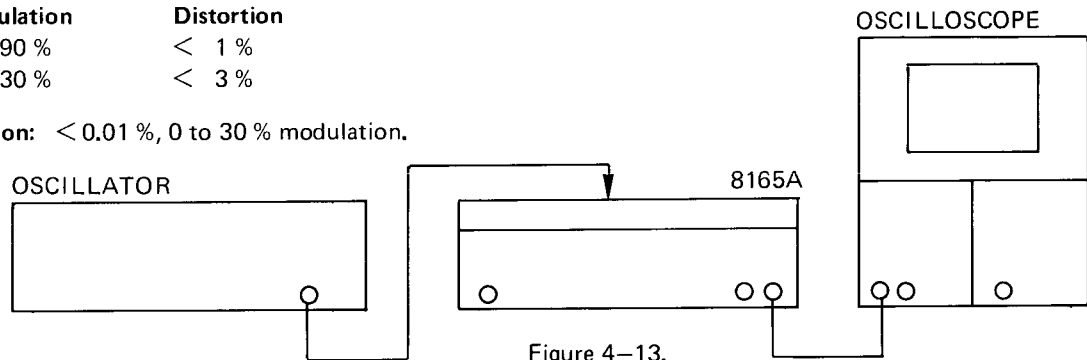

Figure 4-13.

PROCEDURE

1. Connect the equipment as shown in Figure 4-13.
2. Set the 8165A as follows:

INPUT MODE	NORM
FUNCTION	SINE
DUTY CYCLE	50 %
FM	OFF
FRQ	100 kHz
AMPL	
OFFSET	0 V
OUTPUT MODE	ENABLE
		NORM
		50 Ω
SWEEP START	10 kHz
SWEEP STOP	10 kHz
SWEEP TIME	1 s/decade
AM	ON

3. Set oscillator for 1 kHz and 2.5 V_{pp} amplitude.
4. The display should be of a modulation depth of 100 %.

PERFORMANCE TESTS

4–20 STORE/RECALL CAPABILITY

SPECIFICATION

10 addressable store locations plus one for existing operating state. Each location can store a complete set of operating parameters and modes.

Access time: 20 ms each location.

Storage time: internal battery provides memory retention for approx 4 weeks at room temperature.

PROCEDURE

1. Set the 8165A as follows:

INPUT MODE	NORM
FUNCTION	TRIANGLE
DUTY CYCLE	20 %
FM	ON
FRQ	11.11 kHz
AMPL	2 V
OFFSET	+ 1 V
OUTPUT MODE	ENABLE
		NORM
		50 Ω

2. Press STO and 1.

3. Set the 8165A as follows:

INPUT MODE	BURST
FUNCTION	SQUARE
DUTY CYCLE	80 %
FM	OFF
FRQ	19.9 MHz
AMPL	5 V
OFFSET	– 2 V
BURST	99
OUTPUT MODE	DISABLE
		INV
		1 kΩ

4. Press STO and 2.

5. Press RCL and 1, verify that the settings of step 1 are displayed.

6. Press RCL and 2, verify that the settings of step 3 are displayed.

PERFORMANCE TESTS

4–21 HP-IB CAPABILITY

SPECIFICATION

Accuracy: See Frequency Characteristics, Output Characteristics.

Settling times:

Frequency: < 20 ms to $\pm 5\%$ of programmed value. In Norm mode, and in Trig, Gate, Burst at frequencies < 1 kHz : < 70 ms to $\pm 2\%$ of programmed value, < 300 ms to final value.

Other Functions: 20 ms. The following range changes can take up to 200 ms:

Change of duty cycle.

Selection to or from Sweep/VCO.

Changing up to/down from the following decades:

Frequency 1 kHz, 10 kHz, 100 kHz, 1 MHz, 20 MHz.

Amplitude 100 mV, 1 V

Offset 1 V.

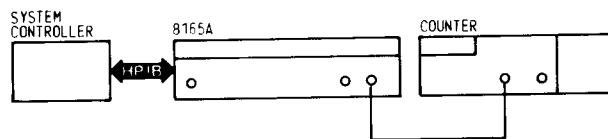

Figure 4–14. Test Setup for HP-IB Operation

EQUIPMENT

- System controller
- Counter
- Cable assembly (1 x 61 cm)

PROCEDURE

1. Connect the equipment as shown in Figure 4–14.
2. Load program presented in Figure 3–16 (modify wait command in step 13 to 10 s — or as desired).
3. Run program and verify functional operation.
4. Verify accuracy of first and last programmed frequencies:

Programmed frequency	Counter reading
440 Hz	440 Hz \pm 4.4 mHz
739.99 Hz	739 Hz \pm 7.4 mHz

PERFORMANCE TESTS

Table 4-4. Performance Test Record (1 of 3)

Hewlett-Packard Company Model 8165A/8165A Option 002 Programmable Signal Source Serial No. _____				Tested By _____ Date _____		
Para. No.	Test Description			Results		
				Actual	Min	Max
4-10	Frequency					
		50.0 MHz		49.9995 MHz	_____	50.0005 MHz
		10.0 MHz		9.9999 MHz	_____	10.0001 MHz
		10.0 kHz		9.9999 kHz	_____	10.0001 kHz
		1.00 kHz		0.9999 kHz	_____	1.00001 kHz
		1.00 Hz		0.99999 s	_____	1.00001 s
	100 mHz		9.99990 s	_____	10.00001 s	
4-11	Burst Number of actual output cycles same as set burst length ?				yes/no	
4-12	Amplitude and Offset					
	OUTPUT MODE	AMPL	FUNCTION			
	1 kΩ	20.0 V	sine	0.693 V	_____	0.721 V
			triangle	0.566 V	_____	0.589 V
			square	0.980 V	_____	1.02 V
	50 Ω	10.0 V	sine	0.347 V	_____	0.361 V
			triangle	0.283 V	_____	0.294 V
			square	0.49 V	_____	0.51 V
	50 Ω	5.00 V	sine *	1.73 V	_____	1.80 V
			triangle *	1.41 V	_____	1.47 V
			square *	2.45 V	_____	2.55 V
	50 Ω	3.00 V	sine *	1.039 V	_____	1.082 V
			triangle *	0.849 V	_____	0.883 V
			square *	1.47 V	_____	1.53 V
	50 Ω	1.00 V	sine *	0.347 V	_____	0.361 V
			triangle *	0.283 V	_____	0.294 V
			square *	0.49 V	_____	0.51 V
	50 Ω	100 mV	sine *	34.7 mV	_____	36.1 mV
			triangle *	28.3 mV	_____	29.4 mV
			square *	49 mV	_____	51 mV
	* Remove 20 dB attenuator					

PERFORMANCE TESTS

Table 4-4. Performance Test Record (2 of 3)

Para No.	Test Description	Results		
		Min	Actual	Max
	<p>OUTPUT OFFSET MODE</p> <p>1 kΩ 10.0 V 50 Ω 5.00 V 50 Ω 3.00 V</p> <p>50 Ω 1.00 V 50 Ω 100 mV</p>	<p>9.880 V 4.930 V 2.950 V</p> <p>0.970 V 79 mV</p>	<p>_____</p> <p>_____</p> <p>_____</p> <p>_____</p> <p>_____</p>	<p>10.12 V 5.070 V 3.050 V</p> <p>1.030 V 121 mV</p>
4-13	<p>Sine Characteristics (Harmonic level)</p> <p>FRQ = 1 MHz (2nd harmonic) FRQ = 1 MHz (3rd harmonic) FRQ = 1 MHz (THD) FRQ = 50 MHz (worst harmonic)</p>		<p>_____</p> <p>_____</p> <p>_____</p> <p>_____</p>	<p>-42 dB -47 dB 1 % -30 dB</p>
4-14	<p>Pulse Characteristics</p> <p>Leading edge Trailing edge Preshoot Overshoot and ringing</p>	<p>≤ -5 % ≤ -5 %</p>	<p>_____</p> <p>_____</p> <p>_____</p> <p>_____</p>	<p>≤ 5 ns ≤ 5 ns ≤ +5 % ≤ +5 %</p>
4-15	<p>Ramp Characteristics</p> <p>Leading edge linearity INV/NORM selection o.k. ?</p>	<p>≤ -1 %</p>	<p>_____</p> <p>yes/no</p>	<p>≤ +1 %</p>
4-16	<p>Gate and Trigger</p> <p>Positive gate releases a burst of output cycles, first and last cycles complete ?</p> <p>Positive trigger releases one complete output cycle ?</p>		<p>_____</p> <p>_____</p> <p>yes/no</p> <p>_____</p> <p>yes/no</p>	
4-17	<p>FM Mode</p> <p>Jitter, FM on Jitter, FM off</p>	<p>1.8 div</p>	<p>_____</p> <p>_____</p>	<p>2.2 div 0.2 div</p>

PERFORMANCE TESTS

Table 4-4. Performance Test Record (3 of 3)

Para No.	Test Description	Results		
		Min	Actual	Max
4-18	Sweep Mode (Option 002 only) Sweep start = sweep stop: 10 kHz 1 MHz 40 MHz	3.5 kHz 600 kHz 33.75 MHz	_____ _____ _____	16.5 kHz 1.4 MHz 46.25 MHz
4-19	Amplitude Modular (Option 002 only) Modulation depth 100 %		_____ yes/no	
4-20	Store/Recall Capability Satisfactory ?		_____ yes/no	
4-21	HP-IB Capability Functionally ? Settling accuracy: 440 Hz 739.99 Hz	439.9956 Hz 738.9926 Hz	_____ yes/no _____ _____	440.0044 Hz 739.0074 Hz
8-6	Safety Check Satisfactory ?		_____ yes/no	

SECTION V ADJUSTMENTS

5-1 INTRODUCTION

5-2 This section describes the adjustments which will return the instrument to peak operating condition after repairs are completed. An adjustment location diagram is given on a fold-out page at the end of this section.

5-3 SAFETY CONSIDERATIONS

5-4 Although this instrument has been designed in accordance with international safety standards, this manual contains information, cautions, and warnings which must be followed to ensure safe operation and to retain the instrument in safe condition (see Sections II and III). Service and adjustments should be performed only by qualified service personnel.

WARNING

Any interruption of the protective (grounding) conductor (inside or outside the instrument) or disconnection of the protective earth terminal is likely to make the instrument dangerous. Intentional interruption is prohibited.

5-5 Any adjustment, maintenance, and repair of the opened instrument with voltage applied should be avoided as much as possible and, when inevitable, should be carried out only by a skilled person who is aware of the hazard involved.

5-6 Capacitors inside the instrument may still be charged even if the instrument has been disconnected from its source of supply.

5-7 Make sure that only fuses with the required rated current and of the specified type (normal blow, time delay, etc.) are used for replacement. The use of repaired fuses and the shortcircuiting of fuseholders must be avoided.

5-8 Whenever it is likely that the protection offered by fuses has been impaired, the instrument must be made inoperative and secured against any unintended operation.

WARNING

Adjustments described herein are performed with power supplied to the instrument while protective covers are removed. Energy available at many points may, if contacted, result in personal injury.

5-9 EQUIPMENT REQUIRED

5-10 The test equipment required for the adjustment procedures is listed in Table 1-1, Recommended Test Equipment. The critical specifications of substitute test instruments must meet or exceed the standards listed in the table if the instrument is to meet the standards set forth in Table 1-2, Specifications.

5-11 ADJUSTMENT PROCEDURE

- § 5-17 Power Supplies
- § 5-18 VCO/Control pre-adjust
- § 5-19 Output Amplifier and Offset Generator
- § 5-20 Pulse Response
- § 5-21 High Frequency Adjustments
- § 5-22 Reference Loop
- § 5-23 Baseline Centering
- § 5-24 Sweep Generator (option 002)
- § 5-25 Amplitude Modulator (option 002)

When repairs have been made, § 5-17 Power Supplies should always be carried out. Of the remaining paragraphs, only those which the repairs could affect need be done. Execute a paragraph completely and in the order in which it is presented. Only the significant instrument settings are given.

5-13 Allow a 1 hour warm-up time before starting the adjustments. During adjustments, keep the covers in place as far as is possible so that the instrument's temperature remains steady.

5-14 ADJUSTMENT RECORD

5-15 Results of adjustments may be tabulated on the Adjustment Record at the end of the adjustment paragraphs.

3.2 Set DVM to 10 V Range (or use a low pass Filter for the 1 V Range). Connect DVM (dc, floating), measure and adjust as follows:

DVM	DVM	Adjust	Result
Low	High		E
A5TP1	A5TP2	—	Note: Voltage E (should lie between + 5 mV and - 5 mV).
A5TP4	A5TP3	A15R33	Adjust for same voltage and polarity as E.

4 TRIANGLE AMPLITUDE (VCO)

4.1 Set DVM to 1 V Range (without low pass Filter). Connect DVM (ac) to A5TP9 and ground. Adjust A5R71 for 695 mV rms ± 1 mV.

5 OUTPUT DRIVER BALANCE

5.1 Set DVM to 10 V range or use a low pass filter for the 1 V Range. Connect DVM (dc, floating) between A5TP10 and A5TP11. Adjust A16R430 for 0 ± 0.5 mV.

5.2 Disconnect DVM.

6 LF D/A CONVERTER: RAMP DISTORTION

6.1 Connect 10:1 scope probe to A10TP1 and set 8165A FRQ to 999 Hz.

6.2 Adjust A10R212 for min. ramp distortion (Figure 5-1).

6.3 Disconnect scope.



Figure 5-1. Ramp Distortion Adjustment

7 HF RAMP DISTORTION

7.1 Set 8165A frequency to 9.999 kHz.

7.2 Connect 10:1 Probe from Analyzer to A5TP10.

7.3 Set Analyzer:

- Resolution bandwidth 300 Hz
- Frequency span/div 5 kHz
- Sweep time/div 0.2 s
- Sweep mode repetitive
- Input sensitivity 0.2 V

7.4 Adjust A15R35 for minimum 2nd harmonic (Figure 5-2). Verify level is 50 dB below fundamental or lower.

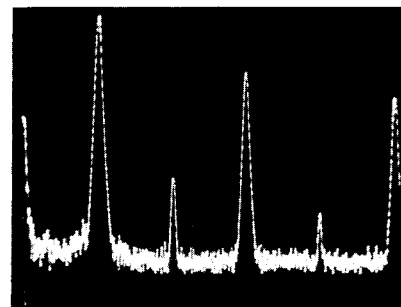

(Figure 5-2. Triangle Distortion Adjustment: LF)

8 TRIANGLE DISTORTION : HF

8.1 Connect the capacitor (0.47 μF) between junction A5R50/R60 and ground.

8.2 Set 8165A FRQ to 50 MHz.

8.3 Adjust A15R37 for minimum 2nd harmonic. (Figure 5-3). Then turn CW to verify level is 50 dB below fundamental.

8.4 Set 8165A FRQ to 20 MHz and check harmonics. If necessary re-adjust A15R37 for best compromise.

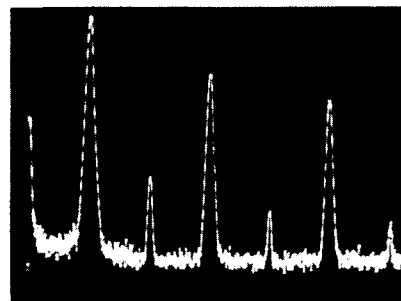

Figure 5-3. Triangle Adjustment: HF
Disconnect spectrum analyzer and capacitor.

9 VCO RANGE 1:999

- 9.1** Connect counter to 8165A's SYNC OUTPUT and set counter as follows:

Function Frequency A
Channel A

- 9.2** Set 8165A's INPUT MODE to VCO and FRQ to 999 kHz.

- 9.3** Connect voltage source via 20 dB Power Attenuator to 8165A's EXT INPUT and adjust source for 1 kHz reading on counter.

- 9.4** Measure voltage source, value should be $10 \text{ mV} \pm 30 \text{ mV}$. Leave at setting obtained in **9.3** for the following adjustment. Disconnect counter.

10 VCO DISTORTION

- 10.1** Connect spectrum analyzer to 8165A's OUTPUT and set analyzer as follows:

Resolution bandwidth 100 Hz
Frequency span/div 1 kHz
Sweep time/div 0.2 s
Sweep mode repetitive

- 10.2** Adjust A15R39 for min 2nd harmonic (Figure 5-4). Verify level is 35 dB below fundamental or lower.

- 10.3** Disconnect voltage source.

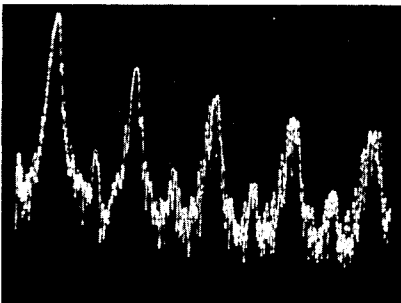

Figure 5-4. VCO Distortion Adjustment

11 HF SINE DISTORTION

- 11.1** Connect spectrum analyzer to 8165A's OUTPUT and set as follows:

Resolution bandwidth 300 Hz
Frequency span/div 5 kHz
Sweep time/div 0.1 s
Sweep mode repetitive

- 11.2** Change the following 8165A settings:

FUNCTION Sine
INPUT MODE Norm
and check that FRQ 9.999 kHz

- 11.3** Change OUTPUT MODE from NORM to COMP and back. Adjust A17R340 for same 3rd harmonic value.

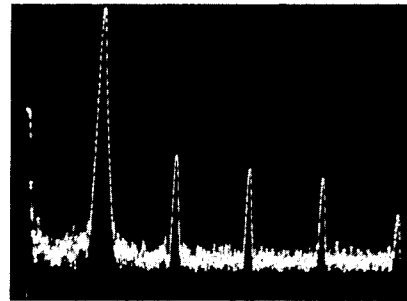

Figure 5-5. Sine Distortion Adjustment: 9.999 kHz

- 11.4** Adjust A16R350 for a 2nd harmonic of -42 dB or slightly better. Check at following settings for best compromise and same level ($< -42 \text{ dB}$).

Connect to HF spectrum analyzer
Settings: FRQ 1 MHz, AMP 1.99 V
FRQ 999 kHz, AMP 2.00 V

- 11.5** Set 8165A FRQ to 999 Hz.
Set spectrum analyzer as follows:

Resolution bandwidth 100 Hz
Frequency span 0.5 kHz
Sweep time2S/Div

- 11.6** Adjust 3rd harmonic with A10R227 and 2nd harmonic with A10R206 for minimum (Figure 5-6). Verify that these levels are $42 \text{ dB}/47 \text{ dB}$ below fundamental or lower.

- 11.7** Disconnect the spectrum analyzer.

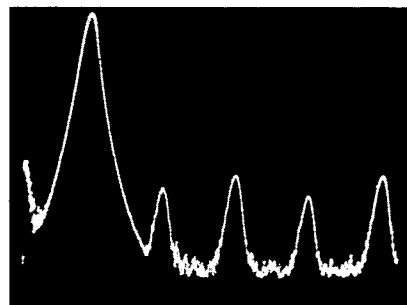

Figure 5-6. Sine Distortion Adjustment: 999 Hz

12 TRIANGLE AMPLITUDE

- 12.1** Connect DVM (ac) to A5TP9 and ground.

- 12.2** Set 8165A FRQ to 110 Hz and TRIANGLE.

- 12.3 Adjust A10R241 for 695 mV rms \pm 1 mV.
- 12.4 Change 8165A frequency to 9.999 kHz. Verify DVM reading of 695 mV \pm 2mV. If not within specification, readjust from step 4 Triangle Amplitude.
- 12.5 Leave DVM in position.
- 13 SINE AND SQUARE AMPLITUDE
- 13.1 Set 8165A FUNCTION to sine. Adjust A17R360 for 850.7 mV rms \pm 1 mV.
- 13.2 Change frequency to 110 Hz. Verify DVM reading of 850.7 mV \pm 2 mV rms. Readjust A10R227. Re-check step 11.6
- 13.3 Set 8165A FUNCTION to square. Frequency to 9.999 kHz. Adjust A17R230 for 1204 mV rms \pm 2 mV.
- 13.4 Set 8165A frequency to 110 Hz. Verify DVM reading of 1204 mV \pm 3 mV rms.
- 14 SINE AND SQUARE BALANCE
- 14.1 Set DVM to 10 V range or use a low pass filter for the 1 V Range. Connect DVM (dc, floating between A5TP10/TP11.
- 14.2 Change 8165A's FUNCTION to sine, FRQ to 9.999 kHz.
- 14.3 Adjust A16R243 for 0 V \pm 1 mV.
- 14.4 Change 8165A's FUNCTION to square, adjust A16R240 for 0 V \pm 1 mV.
- 15 TRIANGLE DC BALANCE
- 15.1 Set 8165A's FUNCTION to triangle, FRQ to 999 Hz, INPUT MODE to TRIG. Leave DVM in its position (step 14.1).
- 15.2 Adjust A10R235 for 0 V \pm 1 mV.

5-19 Output Amplifier and Offset Generator

Pre-condition for this adjustment is a correctly adjusted VCO(5-18).

EQUIPMENT

Digital voltmeter, with cable and termination:
total error < 0.5% at 1 kHz.
Oscilloscope, 1:1 probe

Note: Use shielded cable for all dc-adjustments.

PROCEDURE

1 VOLTAGE SOURCE PRE-AMP BALANCE

1.1 Set 8165A as follows:

INPUT MODE	NORM
FUNCTION	SQUARE
DUTY CYCLE	50 %
FM	OFF
FRQ	999 Hz
AMPL	10.0 V
OFFSET	0.0 V
OUTPUT MODE	ENABLE
		NORM
		50 Ω

1.2 Connect scope via 1:1 probe to A4TP3.

1.3 Adjust A4R161 for minimum amplitude.

1.4 Set 8165A OUTPUT MODE to INV. Verify scope display \leq 10 mV p-p. Find a good compromise in both, NORM and INV output modes.
Disconnect scope.

2 VERNIER D/A CONVERTER

2.1 Set 8165A AMPL to 1.0 V, OUTPUT to NORM, and connect DVM (dc mode) to A6TP1.

2.2 Adjust A6R805 for -4.00 V \pm 3 mV.

2.3 Disconnect DVM.

- 3 OP AMP BALANCE: U3
- 3.1 Set 8165A as follows:
- | | |
|-------------------|-------------|
| OFFSET | + 1.0 V |
| OUTPUT MODE | ENABLE |
| | NORM |
| | 50 Ω |
- 3.2 Connect DVM (dc, floating) to A12TP1/2.
- 3.3 Adjust A12R20 for 0 V \pm 0.1 mV.
- 3.4 OP AMP BALANCE: U2
- 3.5 Connect DVM (dc, floating) to A12TP3/4.
- 3.6 Adjust A12R12 for 0 V \pm 0.1 mV.
- 4 OP AMP BALANCE: U4
- 4.1 Set 8165A OFFSET to -1.0 V.
- 4.2 Connect DVM (dc, floating) to A12TP5/6.
- 4.3 Adjust A12R31 for 0 V \pm 0.1 mV.
Remove DVM.
- 4.4 Set 8165A FRQ to 110 Hz. INPUT MODE to TRIG. OFS to 0 V. FUNCTION to TRIANGLE.
- 5 PRE-AMP DC BALANCE
- 5.1 Connect DVM (dc mode) to 8165A OUTPUT via 50 Ω cable and 50 Ω feedthrough termination. Note: total error DVM/cable/termination must be $< 0.5\%$ at 1 kHz.
- 5.2 While switching 8165A OUTPUT MODE between NORM and INV, adjust A4R111 for a minimum offset change ≤ 5 mV.
- 6 X1 AMPLIFIER BALANCE
- 6.1 Set 8165A AMPL to 1.99 V and OUTPUT MODE to NORM.
- 6.2 Adjust A6R1 for an output offset of 0 V \pm 1 mV.
- 6.3 Set 8165A OUTPUT MODE to INV. Verify offset is 0 V \pm 10 mV.
- 5-6
- 7 X2 AMPLIFIER BALANCE
- 7.1 Set 8165A AMPL to 10 V and OUTPUT MODE to NORM.
- 7.2 Adjust A6R2 for an output offset of 0 V \pm 2 mV.
- 7.3 Set 8165A OUTPUT MODE to INV. Verify offset is 0 V \pm 20 mV.
- 8 X1 AMPLIFIER GAIN
- 8.1 Connect DVM (ac mode) to 8165A OUTPUT via 50 Ω cable and 50 Ω feedthrough termination. Note: total error DVM/cable/termination must be $< 0.5\%$ at 1 kHz.
- 8.2 Set 8165A INPUT MODE to NORM, SQUARE.
- 8.3 Adjust the following amplitude settings:
- | 8165A
AMPL (p-p) | Adjust | DVM
Reading (rms) |
|---------------------|--------|-------------------------|
| 1.99 V | A6R912 | 995 mV rms \pm 1 mV |
| 1.00 V | A6R810 | 500 mV rms \pm 0.5 mV |
| 1.50 V | A6R826 | 750 mV rms \pm 0.5 mV |
- 9 X2 AMPLIFIER GAIN
- 9.1 Leave DVM connected as given in step 8.1.
- 9.2 Adjust the following amplitude settings:
- | 8165A
AMPL | Adjust | DVM
Reading |
|---------------|--------|------------------------|
| 3.99 V | A4R306 | 1.995 V rms \pm 1 mV |
| 5.99 V | A6R920 | 2.995 V rms \pm 2 mV |
| 7.99 V | A6R915 | 3.995 V rms \pm 3 mV |
- 10 OFFSET RANGE
Pre-condition for this adjustment is a correctly adjusted **baseline (5-23 BASELINE CENTERING)**.
- 10.1 Set 8165A OFFSET TO +2.56 V, AMPL 10 mV, INPUT MODE to TRIG, FUNCTION to TRIANGLE.
- 10.2 Connect DVM (dc) to 8165A OUTPUT.
- 10.3 Adjust A6R614 for + 2.560 V \pm 1 mV.

- 11 OFFSET D/A CONVERTER
 - 11.1 Set 8165A OFFSET to + 2.55 V.
 - 11.2 Adjust A6R601 for + 2.550 V ± 1 mV.
- 12 OFFSET: + 999 mV RANGE
 - 12.1 Set 8165A OFFSET to + 999 mV, IMP 50 Ω, AMPL 10 mV.
 - 12.2 Adjust A12R4 for + 999 mV ± 1 mV.
- 13 OFFSET: – 999 mV RANGE
 - 13.1 Set 8165A OFFSET to – 999 mV.
 - 13.2 Adjust A12R23 for – 999 mV ± 1 mV.
 - 13.3 Set 8165A OFFSET to – 5.00 V and verify that DVM reads – 5.000 V ± 30 mV.
 - 13.4 Disconnect DVM.
- 14 OFFSET: LINEARITY
 - 14.1 Set 8165A OFFSET to + 5.00 V, OUTPUT MODE 1 kΩ, AMPL 2 V.
 - 14.2 Adjust A6R610 for + 5.000 V.
 - 14.3 Set 8165A OUTPUT MODE to 50 Ω and verify DVM reads + 5.000 V ± 30 mV.

5–20 PULSE RESPONSE

EQUIPMENT:

- Sampling scope
- Power attenuator 20 dB

- 1 SQUARE WAVE RESPONSE
 - 1.1 Connect sampling scope via 20 dB attenuator and feedthrough termination to 8165A OUTPUT. Trigger from SYNC OUTPUT.

- 1.2 Set 8165A FRQ to 10 MHz, square wave. Adjust for best pulse shape in each of the following ranges:

8165A	Adjust
2 V	A4C106/R115
10.0 V	C513/R526
without 20 dB att.	
999 mV	A4C512/R525
99 mV	A4C511/R524

Verify that, in all cases, overshoot (Figure 4–9) ≤ ± 5 % of amplitude, transition times ≤ 5 ns.

Verify that with AMPL 1.99 V, 1 V and 100mV overshoot ≤ ± 5 % of amplitude, transition times ≤ 5 ns.

- 1.3 Set 8165A OUTPUT MODE to 1 kΩ and verify that the transition times at the above amplitude ranges are ≤ 7 ns and pulse perturbation is ≤ ± 10 %.

5–21 HIGH FREQUENCY ADJUSTMENTS

EQUIPMENT:

- Sampling scope
- Power attenuator 20 dB
- DVM
- Voltage source (TTL)
- Power Meter
- Power Sensor

- 1 VCO CONTROL ADJUST

- 1.1 Set 8165A as follows:

INPUT MODE GATE
FUNCTION TRIANGLE
DUTY CYCLE 50 %
FM OFF
FRQ 20 MHz
AMPL 1.99 V
OFFSET 0 V
OUTPUT MODE ENABLE
 NORM
 50 Ω

- 1.2 Connect voltage source to EXT INPUT. Connect counter to 8165A output.
- 1.3 Adjust A8R407 for 20 MHz ± .5 %.
- 1.4 Set 8165A FRQ to 35 MHz.

- 1.5 Adjust A8R420 for 35 MHz \pm .5 MHz/ \pm 0 MHz.
- 1.6 Remove counter, connect sampling scope to output.
- 1.7 Set 8165A FRQ to 1 MHz.
Set sampling scope for 100 % display as reference.
- 1.8 Set 8165A FRQ for 50 MHz.
Adjust A5R10/R51 for a HIL -10 %
and a LOL -5 %.
- 1.9 Repeat steps 1.3 to 1.5 with counter.
- 1.10 Set 8165A FRQ to 50 MHz
Adjust A8R418 for 50.0 MHz
 \pm .5 MHz/ -0 MHz.
- 1.11 Repeat steps 1.6 to 1.10 for optimum.
- 2 VCO CONTROL FRQ ADJUST
- 2.1 Set 8165A FRQ to 1 MHz, SQUARE
connect sampling scope to output and set
display for 100 % as reference.
- 2.2 Set 8165A FRQ to 50 MHz, SINE
Adjust A5C309 for an ampl. of -2 %.
Check at 35 MHz (2 V) and find best
compromise.
- 2.2.1 Connect Power Meter to output and check
power for 9.90 mW \pm 1.65 mW/ -1.52 mW
in both, NORM and INV output modes.
- 2.2.2 Set 8165A FRQ to 35 MHz,
check power for 9.90 mW \pm 1.65 mW/ -1.52 mW
in both, NORM and INV output modes.
- 2.2.3 Set 8165A FRQ to 1 MHz.
Check power for 9.90 mW \pm 0.6 mW/ -0.58 mW
in both, NORM and INV output modes.
- 2.3 Set 8165A to SQUARE.
FRQ 50 MHz and connect sampling scope
to output
Adjust A5R235 for 50 % duty cycle.
Check at 35 MHz and find best compromise.
- 2.4 Set 8165A FRQ to 19.9 MHz
DUTY CYCLE 20 %, TRIANGLE

Adjust A8R412 for 19.3 MHz
 \pm 200 kHz/ -0 kHz.
- 2.5 Set 8165A FRQ to 10.0 MHz.
- 2.6 Find best compromise between 10 MHz and
19.9 MHz in all duty cycle modes for better 4 %.
- 2.7 Set 8165A FRQ to 9.99 MHz
DUTY CYCLE 50 %

Adjust A4R409 for 10.0 MHz \pm .1 MHz / -0 MHz.
- 2.8 Set 8165A to 1 MHz.

Check frequency in all duty cycle modes
for better 4 %.
- 2.9 Set 8165A FRQ to 999 kHz
DUTY CYCLE 80 %.

Adjust A8R405 for 962 kHz \pm 10 kHz,
 -0 kHz.
- 2.10 Set 8165A FRQ for 100 kHz check frequency
in all duty cycle modes for better 4 %.
-
- 5-22 Reference Loop**
-
- EQUIPMENT**
- Counter
 - Spectrum analyzer
 - Pulse generator
 - Voltage source
 - Oscilloscope
 - 10:1 probe
 - 1:1 probe
- PROCEDURE**
- 1 OSCILLATOR FREQUENCY
- 1.1 Set 8165A as follows:
- INPUT MODE NORM
FUNCTION SQUARE
DUTY CYCLE 50 %
FRQ 10 MHz
- 1.2 Connect counter to SYNC OUTPUT.
- 1.3 Adjust A9C602 for a frequency of 10.000000 MHz
 \pm 5 mHz.
- 1.4 Disconnect counter.
- 5-8

- 2 SINE SHAPER DISTORTION (PLL)
 - 2.1 Connect scope to A9TP4 via 10:1 probe.
 - 2.2 Set 8165A INPUT MODE to GATE and FRQ to 3 kHz.
 - 2.3 Apply + 1 V from voltage source to 8165A EXT INPUT.
 - 2.4 Adjust with A9R313 and A9R310 the signal amplitude and offset for best sine waveform.
 - 2.5 Check the signal waveform between 1 kHz and 9.9 kHz.
 - 2.6 Re-adjust A9R313, R310, if necessary, for best compromise.
- 3 MIXER BALANCE
 - 3.1 Connect scope via 10:1 probe to A9TP5.
 - 3.2 Set 8165A to 2 kHz.
 - 3.3 Adjust A9R406 for min. pulse amplitude.
 - 3.4 Check the pulse amplitude between 1 kHz and 9.9 kHz for ≤ 130 mVp-p.

- 1.3 Set 8165A INPUT MODE to GATE, FRQ to 1 kHz.
- 1.4 Adjust A7R4 for a stable gated output signal.
- 1.5 Check operation with 8165A FRQ 999 Hz.
- 2 GATE BASELINE
 - 2.1 Connect pulse generator output to 8165A's EXT INPUT, pulse generator trigger output to scope ext trigger, 8165A OUTPUT to scope channel A.
 - 2.2 Set pulse generator to square wave, baseline 0 V, pulse to + 2 V, rate 1.00 MHz. Set 8165A as follows:

```

INPUT MODE ..... GATE
FUNCTION ..... Triangle
DUTY CYCLE ..... 50 %
FRQ ..... 19.9 MHz
OFFSET ..... 0.0 V
    
```

- 2.3 Observe gated output waveform on scope. Adjust A5R115 to center baseline (Figure 5-9).

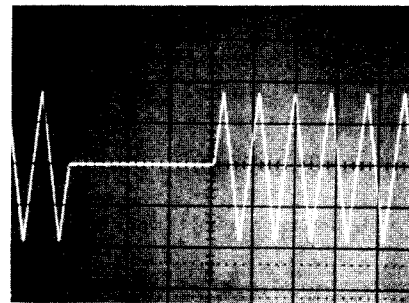

Figure 5-9. Gate Baseline Adjustment

- 2.4 Change frequency and observe baseline. Shift should be $\leq 3\%$.
- 2.5 Change duty cycle and observe baseline. Shift should be $\leq 4\%$.

5-23 BASELINE CENTERING

- 1 EXTERNAL TRIGGER LEVEL
 - 1.1 Set external pulse generator to: frequency 500 Hz, amplitude 200 mV p-p, offset + 50 mV.
 - 1.2 Connect pulse generator to EXT INPUT and oscilloscope to 8165A output.

5-24 Sweep Generator (Option 002 only)

EQUIPMENT

Digital voltmeter
Counter

PROCEDURE

Check first which revision is installed in your instrument. The following procedure is written for revision F.

For revisions C and D, E see the backdating session.

1 SWEEP VOLTAGE

1.1 Set 8165A as follows:

INPUT MODE	SWEEP EXT
FUNCTION	Triangle
DUTY CYCLE	50 %
FM	OFF
FRQ	1 kHz
AMPL	2 V
OFFSET	0 V
OUTPUT MODE	ENABLE
		NORM
		50 Ω
SWEEP START	990 kHz
SWEEP STOP	990 kHz
SWEEP TIME	1

1.2 Connect DVM (dc) without 50 Ω to rear panel SWEEP OUT connector (or A11TP2).

1.3 Adjust A11R410 for 3.00 V ± 5 mV.

1.4 Set 8165A SWEEP START to 1 kHz.

1.5 Adjust A11R404 for 0 V ± 2 mV

2 SWEEP FREQUENCY

2.1 Connect counter to SYNC OUTPUT
set SWP STA to .99 MHz
set STP to .99 MHz. Press STO 1
set SWP STA to .10 MHz
and STP to 999 kHz. Press STO 2
set SWP STA to 1 kHz
and STP to 999 kHz. Press STO 3

2.2 Press RCL 1
check frequency for 999 kHz ± 5 %

2.3 Press RCL 2
check frequency for 105 kHz ± 5 kHz

2.4 Press RCL 3
check frequency for 1 kHz ± 5 %

If one of the tests above fails perform following procedure.

2.5 Press RCL 1
Adjust A11R428 for 999 kHz ± 3 %

2.6 Press RCL 2
Adjust A11R423 for a reading ratio of 10:1 between RCL 1 (999 K) and RCL 2 (100 K) A11R423 does respond to the high and low end.

Example:
RCL 1 reading 805 K
RCL 2 reading 80.5 K

2.7 Press RCL 1
Adjust A11R428 for 999 kHz ± 3 %

2.8 Press RCL 3
Adjust A11R433 for 1 kHz ± 5 %

2.9 Re-check steps 2.2 to 2.4.
and re-adj. if necessary

2.10 Check with DUTY CYCLE 20 % ,
80 % for ± 10 %

3 SWEEP TIME

3.1 Connect counter to SWEEP OUTPUT.

3.2 Set 8165A to:

SWEEP TRIGGER	INT
SWEEP START	99 kHz
SWEEP STOP	990 kHz
SWEEP TIME	0.01 sec/dec

3.3 Adjust A11R203 for a 20 ms period

5-24 Sweep Generator (Option 002 only)

EQUIPMENT

Digital voltmeter
Counter

PROCEDURE

Check first which revision is installed in your instrument. The following procedure is valid for revision C.

1 SWEEP VOLTAGE

1.1 Set 8165A as follows:

INPUT MODE	SWEEP EXT
FUNCTION	Triangle
DUTY CYCLE	50 %
FM	OFF
FRQ	1 kHz
AMPL	2 V
OFFSET	0 V
OUTPUT MODE	ENABLE
		NORM
		50 Ω
SWEEP START	990 kHz
SWEEP STOP	990 kHz
SWEEP TIME	1

1.2 Connect DVM (dc) to rear panel SWEEP OUT connector (or A11TP2).

1.3 Adjust A11R410 for 3.00 V ± 5 mV.

1.4 Set 8165A SWEEP START to 1 kHz.

1.5 Adjust A11R404 for 0 V ± 2 mV.

2 SWEEP FREQUENCY

2.1 Connect counter to SYNC OUTPUT and adjust A11R423 for 1.00 kHz reading on counter.

2.2 Set 8165A SWEEP START to 990 kHz.

2.3 Adjust A11R428 for 990 kHz reading on counter.

2.4 Set 8165A SWEEP START to 100 kHz.

2.5 Adjust A11R426 for 100 kHz reading on counter.

2.6 Set sweep start to 1.00 kHz. Check for 1 kHz ± 5 %.

2.7 Set sweep start to 990 kHz. Check for 990 kHz ± 2 %.

2.8 Set sweep start to 100 kHz. Check for 100 kHz ± 2 %.

2.9 Repeat steps 2.1 to 2.5 if necessary.

2.10 Check with DUTY CYCLE 20 %, 80 % for ± 10 %

3 SWEEP TIME

3.1 Connect counter to SWEEP OUTPUT.

3.2 Set 8165A to:

SWEEP TRIGGER	INT
SWEEP START	99 kHz
SWEEP STOP	990 kHz
SWEEP TIME	0.01 sec/dec

3.3 Adjust A11R203 for a 20 ms period.

5-24 Sweep Generator (Option 002 only)

EQUIPMENT

Digital voltmeter
Counter

PROCEDURE

Check first which revision is installed.
The following procedure is written for revision D and E.

1 SWEEP VOLTAGE**1.1 Set 8165A as follows:**

INPUT MODE	SWEEP EXT
FUNCTION	Triangle
DUTY CYCLE	50 %
FM	OFF
FRQ	1 kHz
AMPL	2 V
OFFSET	0 V
OUTPUT MODE	ENABLE
		NORM
		50 Ω
SWEEP START	990 kHz
SWEEP STOP	990 kHz
SWEEP TIME	1

2 SWEEP FREQUENCY

- 2.1 Connect counter to SYNC OUTPUT.
Set A11R423, R428 fully CW.
- 2.2 Set SWP STA to .5 MHz and STP to 10 MHz
Press STO 4
- 2.3 Set SWP STA to .99 MHz and STP to
.99 MHz. Press STO 1
- 2.4 Set SWP STA to 1 kHz and STP to
.99 MHz. Press STO 2
- 2.5 Set SWP STA to .1 MHz and STP to
.99 MHz. Press STO 3
- 2.6 Press RCL 1
Adjust A11R428 for max. possible frequency.
- 2.7 Press RCL 2
Adjust A11R423 to 3 kHz \pm 5 %.
- 2.8 Press RCL 1
Adjust A11R428 for 990 kHz \pm 3 %.
- 2.9 Press RCL 2
Adjust A11R423 for 1 kHz \pm 5 %.

- 2.10 Press RCL 3
check frequency for 110 kHz \pm 5 kHz

If out of tolerance repeat steps 2.8 to 2.10
for best compromise.

- 2.11 A11R426 has very little effect only and needs
usually no calibration.

- 2.12 Check with DUTY CYCLE 20 % ,
80 % for \pm 10 %

3 SWEEP TIME

- 3.1 Connect counter to SWEEP OUTPUT.

- 3.2 Set 8165A to:

SWEEP TRIGGER	INT
SWEEP START	99 kHz
SWEEP STOP	990 kHz
SWEEP TIME	0.01 sec/dec

- 3.3 Adjust A11R203 for a 20 ms period.

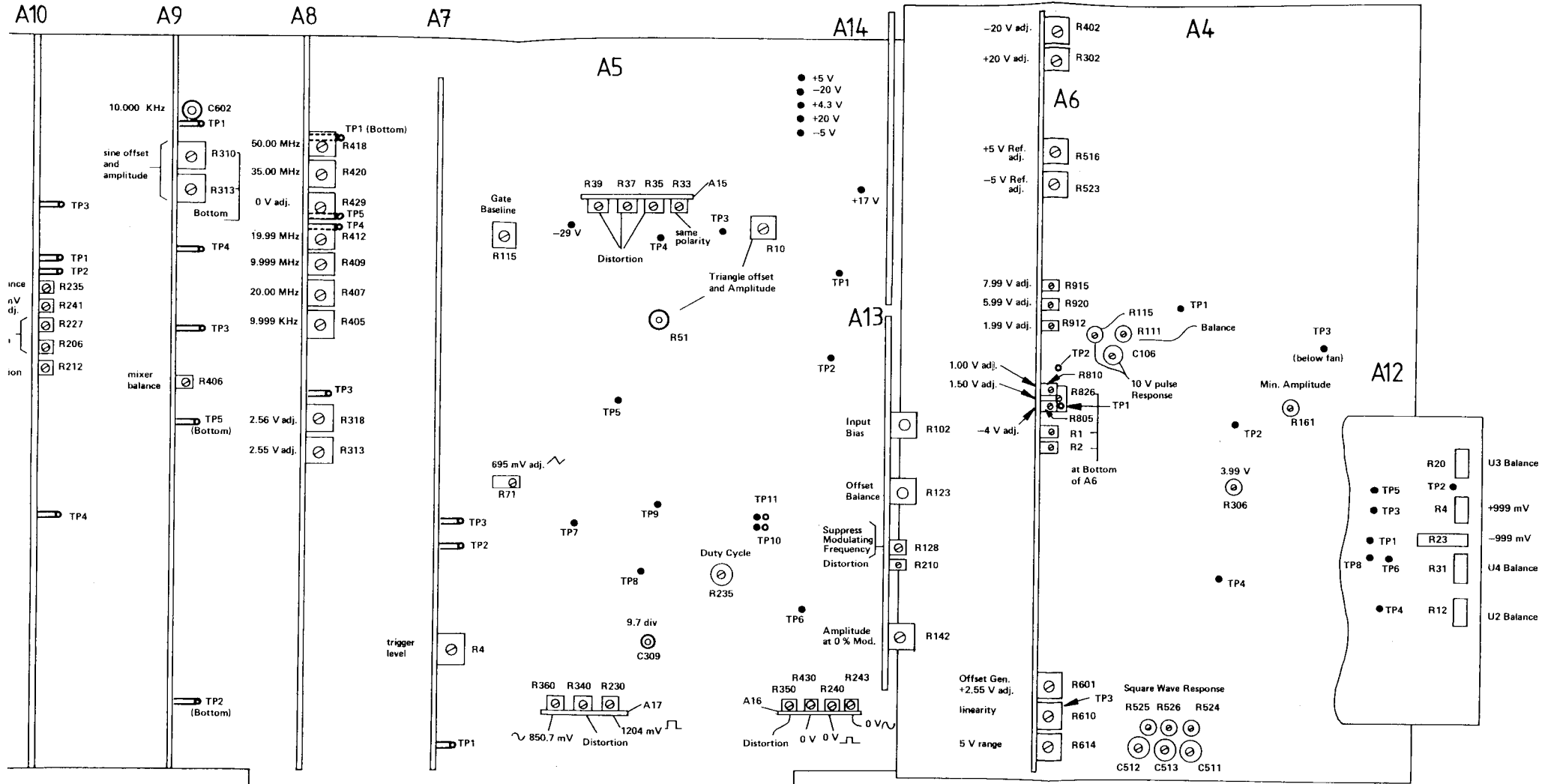

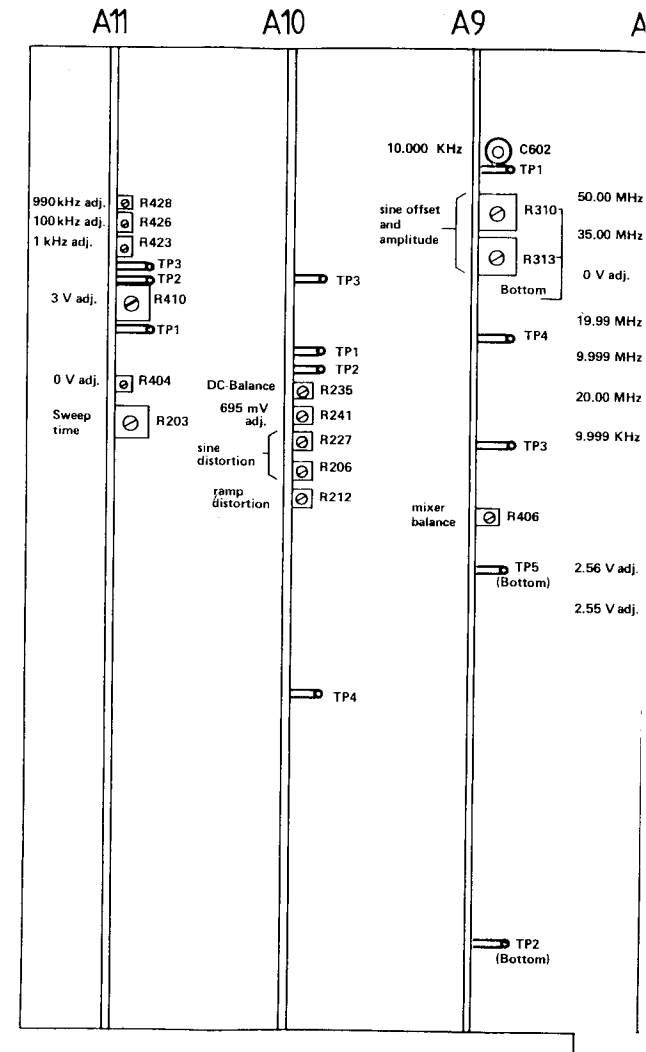
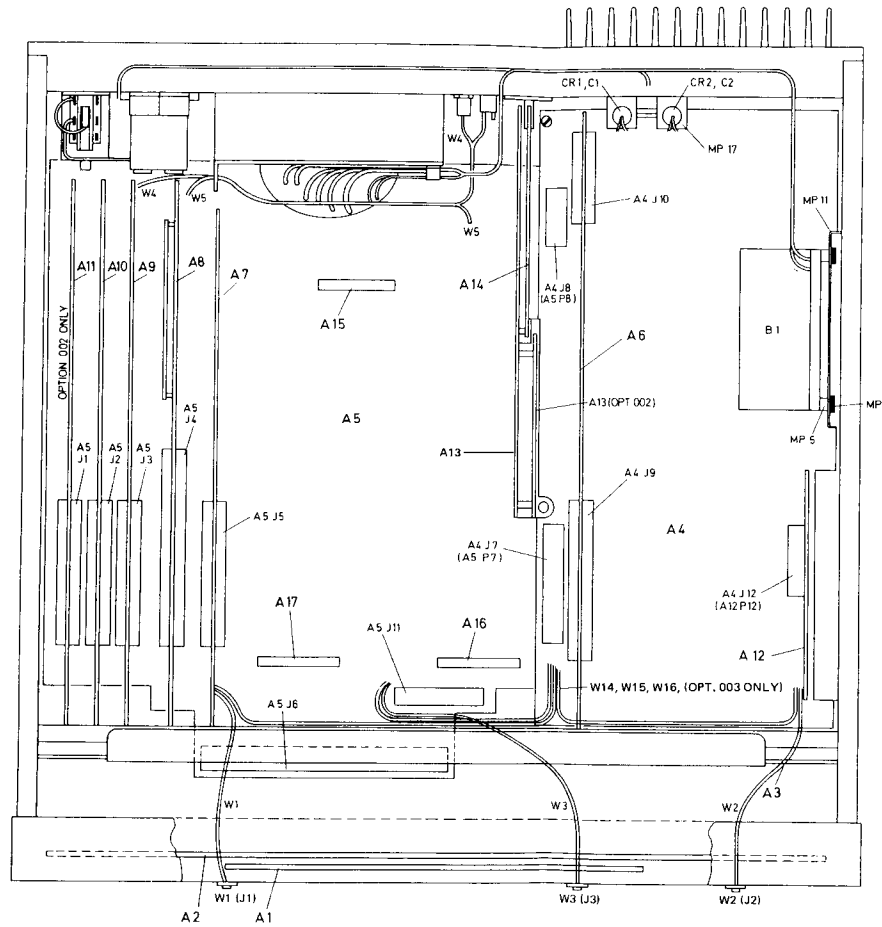

SECTION VI REPLACEABLE PARTS

6-1 INTRODUCTION

6-2 This section contains information for ordering parts. Table 6-1 lists abbreviations used in the parts lists and elsewhere in the manual. Table 6-3 lists all replaceable parts in reference designator order. Table 6-2 contains the names and addresses that correspond to the manufacturer code numbers.

6-3 EXCHANGE ASSEMBLIES

6-4 Hewlett-Packard operates a blue stripe exchange program for the microprocessor board A3 (08165-66503).

6-5 ABBREVIATIONS

6-6 Table 6-1 lists abbreviations used in the parts lists, schematics and elsewhere in the manual. In some cases two forms of the abbreviation are used, one all in capital letters, and one partial or no capitals. This occurs because the abbreviations in the parts lists are always all capitals. However, in the schematics and other parts of the manual, the same abbreviations may have upper and lower case letters.

6-7 REPLACEABLE PARTS LIST

6-8 Table 6-2 is the list of replaceable parts and is organised as follows:

- a. Mainframe (chassis) parts in alphanumeric order by reference designation.
- b. Electrical assemblies and their components in alpha-numerical order by reference designation.

Reference designators are of the form A5R9 i.e. resistor 9 on assembly 5. See Table 6-3. Mainframe parts are not prefixed.

6-9 The information given for each part consists of the following:

- a. The Hewlett-Packard part number.
- b. The total quantity (Qty) in the instrument. This is given only once for each part — at the first appearance of the part in the list.
- c. The description of the part.
- d. A typical manufacturer of the part in a five-digit code.
- e. The manufacturer's code number for the part.
- f. Part number check digit (CD).

6-10 ORDERING INFORMATION

6-11 To order a part listed in the replaceable parts table, quote the Hewlett-Packard part number (with check digit), indicate the quantity required, and address the order to the nearest Hewlett-Packard office (list of Sales/Service offices at the rear of this manual). The check digit will ensure accurate and timely processing of your order.

6-12 To order a part that is not listed in the replaceable parts table, include the instrument model number, instrument serial number, the description and function of the part, and the number of parts required, address the order to the nearest Hewlett-Packard office.

6-13 SPARE PARTS KIT

6-14 Stocking spare parts for an instrument is often done to ensure quick return to service after a malfunction occurs. Hewlett-Packard has a Spare Parts Kit available for this purpose. The kit consists of selected replaceable assemblies and components for this instrument. The contents of the kit and the Recommended Spares list are based on failure reports and repair data, and parts support for one year. A Recommended Spares list for this instrument may be obtained on request and the Spare Parts Kit may be ordered through your nearest Hewlett-Packard office.

6-15 DIRECT MAIL ORDER SYSTEM

6-16 Within the USA, Hewlett-Packard can supply parts through a direct mail order system. Advantages of using the system are as follows:

- a. Direct ordering and shipment from the HP Parts Center in Mountain View, California.
- b. No maximum or minimum on any mail order (there is a minimum order amount for parts ordered through a local HP office when the orders require billing and invoicing).
- c. Prepaid transportation (there is a small handling charge for each order).
- d. No invoices — to provide these advantages, a check or money order must accompany each order.

6-17 Mail order forms and specific ordering information is available through your local HP office. Addresses and phone numbers are located at the back of this manual.

Table 6-1. Abbreviations for Replaceable Parts List

REFERENCE DESIGNATIONS

<p>A assembly AT attenuator; isolator; termination B fan; motor BT battery C capacitor CP coupler CR diode; diode thyristor; varactor DC directional coupler DL delay line DS annunciator; signaling device (audible or visual); lamp; LED</p>	<p>E miscellaneous electrical part F fuse FL filter H hardware HY circulator J electrical connector (stationary portion); jack K relay L coil; inductor M meter MP miscellaneous mechanical part</p>	<p>P electrical connector (movable portion); plug Q transistor; SCR; triode thyristor R resistor RT thermistor S switch T transformer TB terminal board TC thermocouple TP test point U integrated circuit; microcircuit V electron tube</p>	<p>VR voltage regulator; breakdown diode W cable; transmission path; wire X socket Y crystal unit (piezo- electric or quartz) Z tuned cavity; tuned circuit</p>
--	---	--	---

ABBREVIATIONS

<p>A ampere ac alternating current ACCESS accessory ADJ adjustment A/D analog-to-digital AF audio frequency AFC automatic frequency control AGC automatic gain control AL aluminum ALC automatic level control AM amplitude modula- tion AMPL amplifier APC automatic phase control ASSY assembly AUX auxiliary avg average AWG American wire gauge BAL balance BCD binary coded decimal BD board BE CU beryllium copper BFO beat frequency oscillator BH binder head BKDN breakdown BP bandpass BPF bandpass filter BRS brass BWO backward-wave oscillator CAL calibrate ccw counter-clockwise CER ceramic CHAN channel cm centimeter CMO cabinet mount only COAX coaxial COEF coefficient COM common COMP composition COMPL complete CONN connector CP cadmium plate CRT cathode-ray tube CTL complementary transistor logic</p>	<p>CW continuous wave cw clockwise cm centimeter D/A digital-to-analog dB decibel dBm decibel referred to 1 mW dc direct current deg degree (temperature interval or difference) ° degree (plane angle) °C degree Celsius (centigrade) °F degree Fahrenheit °K degree Kelvin DEPC deposited carbon DET detector diam diameter DIA diameter (used in parts list) DIFF AMPL differential amplifier div division DPDT double-pole, double-throw DR drive DSB double sideband DTL diode transistor logic DVM digital voltmeter FCL emitter coupled logic EMF electromotive force EDP electronic data processing ELECT electrolytic ENCAP encapsulated EXT external F farad FET field-effect transistor F/F flip-flop FH flatt head FIL H fillister head FM frequency modulation FP front panel FREQ frequency FXD fixed g gram GE germanium GHz gigahertz GL glass GRD ground(ed) H henry</p>	<p>h hour HET heterodyne HEX hexagonal HD head HDW hardware HF high frequency HG mercury HI high HP Hewlett-Packard HPF high pass filter HR hour (used in parts list) HV high voltage Hz Hertz IC integrated circuit ID inside diameter IF intermediate frequency IMPG impregnated in inch INCD incandescent INCL include(s) INP input INS insulation INT internal kg kilogram kHz kilohertz kΩ kilohm kV kilovolt lb pound LC inductance- capacitance LED light-emitting diode LF low frequency LG long LH left hand LIM limit LIN linear taper (used in parts list) lin linear LK WASH lock washer LO low; local oscillator LOG logarithmic taper (used in parts list) log logarithm(ic) LPF low pass filter LV low voltage m meter (distance) mA milliamperes MAX maximum MΩ megohm MEG meg (10⁶) (used in parts list) MET FLM metal film</p>	<p>MET OX metallic oxide MF medium frequency; microfarad (used in parts list) MFR manufacturer mg milligram MHz megahertz mH millihenry mho mho MIN minimum min minute (time) ' minute (plane angle) MINAT miniature mm millimeter MOD modulator MOM momentary MOS metal-oxide semiconductor ms millisecond MTG mounting MTR meter (indicating device) mV millivolt mVac millivolt, ac mVdc millivolt, dc mVpk millivolt, peak mVp-p millivolt, peak- to-peak mVrms millivolt, rms mW milliwatt MUX multiplex MY mylar μA microampere μF microfarad μH microhenry μmho micromho μs microsecond μV microvolt μVac microvolt, ac μVdc microvolt, dc μVp-p microvolt, peak- to-peak μVrms microvolt, rms μW microwatt nA nanoampere NC no connection N/C normally closed NE neon NEG negative nF nanofarad NI PL nickel plate N/O normally open NOM nominal</p>
---	--	--	---

NOTE

All abbreviations in the parts list will be in upper-case.

Table 6-1. Abbreviations for Replaceable Parts List (cont'd)

NORM normal	POT potentiometer	SI silicon	VFO variable-frequency oscillator
NPN negative-positive-negative	p-p peak-to-peak	SIL silver	VHF very-high frequency
NPO negative-positive zero (zero temperature coefficient)	PP peak-to-peak (used in parts list)	SL slide	Vpk volts, peak
NRRF not recommended for field replacement	PPM pulse-position modulation	SNR signal-to-noise ratio	Vp-p volts, peak-to-peak
NSR not separately replaceable	PREAMPL preamplifier	SPDT single-pole, double-throw	Vrms volts, rms
ns nanosecond	PRF pulse-repetition frequency	SPG spring	VSWR voltage standing wave ratio
nW nanowatt	PRR pulse repetition rate	SR split ring	VTO voltage-tuned oscillator
OBD order by description	PS picosecond	SPST single-pole, single-throw	VTVM Vacuum-tube voltmeter
OD outside diameter	PT point	SSB single sideband	V(X) volts, switched
OH oval head	PTM pulse-time modulation	SST stainless steel	W watt
OP AMPL operational amplifier	PTM pulse-time modulation	STL steel	W with
OPT option	PWM pulse-width modulation	SQ square	WIV working inverse voltage
OSC oscillator	PWV peak working voltage	SWR standing-wave ratio	WW wirewound
OX oxide	RC resistance-capacitance	SYNC synchronize	W/O without
oz ounce	RECT rectifier	T timed (slow-blow fuse)	YIG yttrium-iron-garnet
Ω ohm	REF reference	TA tantalum	Z ₀ characteristic impedance
P peak (used in parts list)	REG regulated	TC temperature compensating	
PAM pulse-amplitude modulation	REPL replaceable	TD time delay	
PC printed circuit	RF radio frequency	TERM terminal	
PCM pulse-code modulation; pulse-count modulation	RFI radio frequency interference	TFT thin-film transistor	
PDM pulse-duration modulation	RH round head; right hand	TGL toggle	
pF picofarad	RLC resistance-inductance-capacitance	THD thread	
PH BRZ phosphor bronze	RMO rack mount only	THRU through	
PHL Phillips	rms root-mean-square	TI titanium	
PIN positive-intrinsic-negative	RND round	TOL tolerance	
PIV peak inverse voltage	ROM read-only memory	TRIM trimmer	
pk peak	R&P rack and panel	TSTR transistor	
PL phase lock	RWV reverse working voltage	TTL transistor-transistor logic	
PLO phase lock oscillator	S scattering parameter	TV television	
PM phase modulation	s second (time)	TVI television interference	
PNP positive-negative-positive	" second (plane angle)	TWT traveling wave tube	
P/O part of	S-B slow-blow (fuse) (used in parts list)	U micro (10 ⁶) (used in parts list)	
POLY polystyrene	SCR silicon controlled rectifier; screw	UF microfarad (used in parts list)	
PORC porcelain	SE selenium	UHF ultrahigh frequency	
POS positive; position(s) (used in parts list)	SECT sections	UNREG unregulated	
POSN position	SEMICON semiconductor	V volt	
	SHF superhigh frequency	VA voltampere	
		Vac volts, ac	
		VAR variable	
		VCO voltage-controlled oscillator	
		Vdc volts, dc	
		VDCW volts, dc, working (used in parts list)	
		V(F) volts, filtered	

MULTIPLIERS

Abbreviation	Prefix	Multiple
T	tera	10 ¹²
G	giga	10 ⁹
M	mega	10 ⁶
k	kilo	10 ³
da	deka	10
d	deci	10 ⁻¹
c	centi	10 ⁻²
m	milli	10 ⁻³
μ	micro	10 ⁻⁶
n	nano	10 ⁻⁹
p	pico	10 ⁻¹²
f	femto	10 ⁻¹⁵
a	atto	10 ⁻¹⁸

NOTE

All abbreviations in the parts list will be in upper case.

Table 6-2. Manufacturers Code List

VFR NO.	MANUFACTURER NAME	ADDRESS	ZIP CODE
02549	VALVO GMBH	HAMBURG	GM
00001	GTE SYLVANIA MINIATURE LT PROD	HILLSBORO	NH
00000	ANY SATISFACTORY SUPPLIER		03244
00040	UNIROOF COMPUTER PRODUCTS CORP	METHUEN	MA
01121	ALLEN-BRADLEY CO	MILWAUKEE	WI
01295	TEXAS INSTR INC SEMICOND CMPNT DIV	DALLAS	TX
01929	RCA CORP SOLID STATE DIV	SOMERVILLE	NJ
02111	SPECTROL ELECTRONICS CORP	CITY OF IND	CA
03884	KODI PYROFILM CORP	WHIPPANY	NJ
04713	MOTOROLA SEMICONDUCTOR PRODUCTS	PHOENIX	AZ
07263	FAIRCHILD SEMICONDUCTOR DIV	MOUNTAIN VIEW	CA
11236	CTS OF BERNE INC	BERNE	IN
14324	SIGNETICS CORP	SUNNYVALE	CA
19701	MEPCOELECTRA CORP	MINERAL WELLS	TX
20932	EMCON DIV ITW	SAN DIEGO	CA
21936	PAYOTOR DIV WILLIAM J PIRNY	BURLINGAME	CA
24044	TRANSITRON ELECTRONIC CORP	WAKEFIELD	MA
24546	CORNING GLASS WORKS (BRADFORD)	BRADFORD	PA
27014	NATIONAL SEMICONDUCTOR CORP	SANTA CLARA	CA
28480	HEWLETT-PACKARD CO CORPORATE HQ	PALO ALTO	CA
32293	INTERFIL INC	CUPERTINO	CA
32997	BOJHNS INC TRIMPOT PROD DIV	RIVERSIDE	CA
34649	INTEL CORP	MOUNTAIN VIEW	CA
51642	CENTRE ENGINEERING INC	STATE COLLEGE	PA
52761	STETTNER-TRUSH INC	CAZENOVIA	NY
56289	SPRAGUE ELECTRIC CO	NORTH ADAMS	MA
72136	ELECTRO MOTIVE CORP SUR IEC	WILLIMANTIC	CT
73134	BECKMAN INSTRUMENTS INC HELIPOT DIV	FULLERTON	CA
75042	TRW INC PHILADELPHIA DIV	PHILADELPHIA	PA
75915	LITTELFUSE INC	DES PLAINES	IL

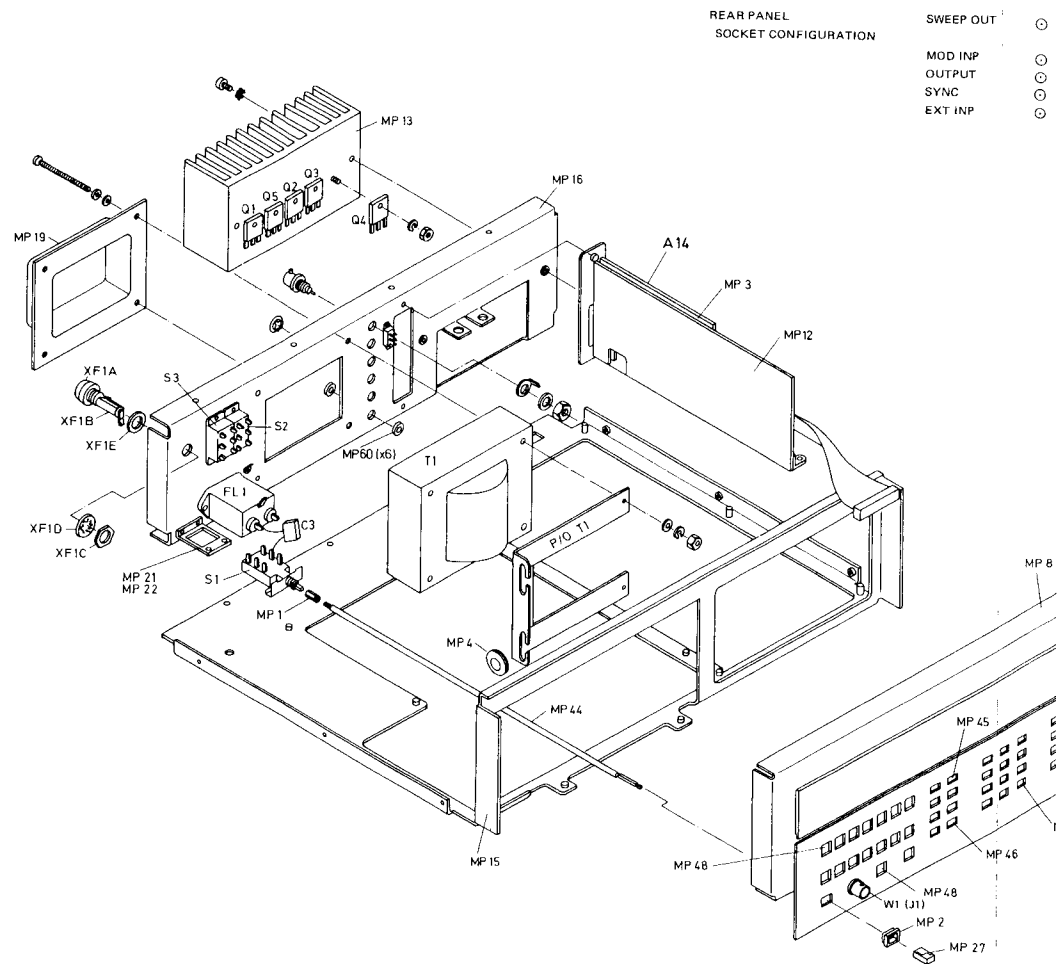
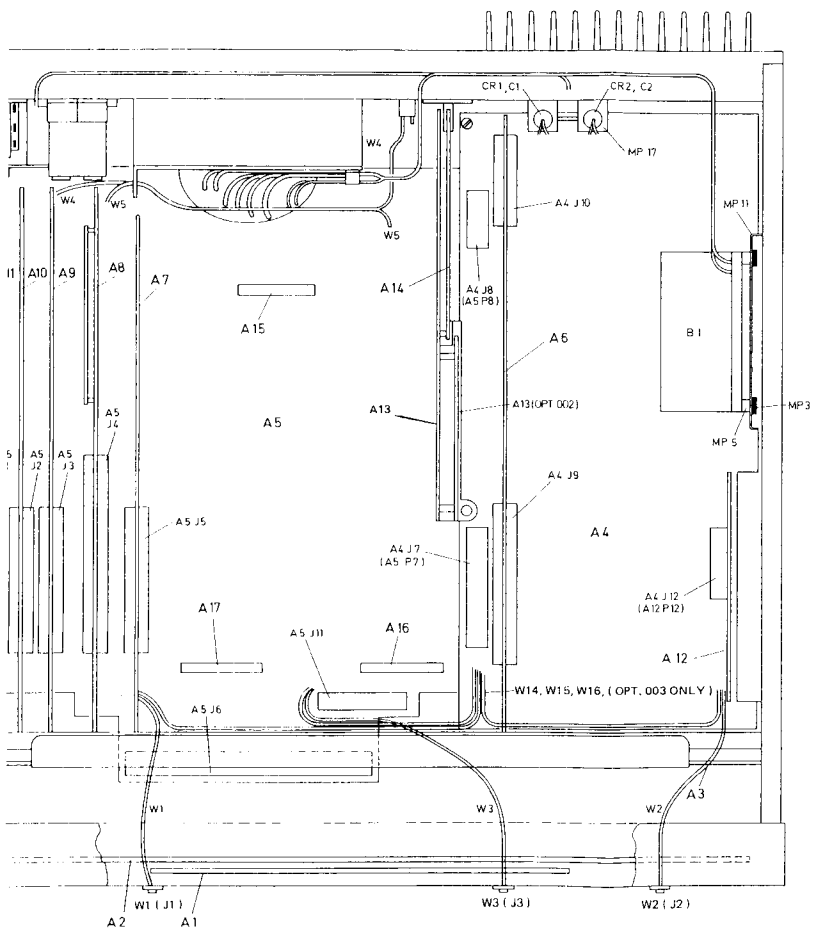

REAR PANEL
SOCKET CONFIGURATION

- SWEEP OUT ○
- MOD INP ○
- OUTPUT ○
- SYNC ○
- EXT INP ○

REAR PANEL
SOCKET CONFIGURATION

- | | | |
|-----------|------------|----------------|
| SWEEP OUT | ○ J5 | } OPT 003 ONLY |
| MOD INP | ○ J6 | |
| OUTPUT | ○ W16 (J2) | |
| SYNC | ○ W15 (J3) | |
| EXT INP | ○ W14 (J1) | |

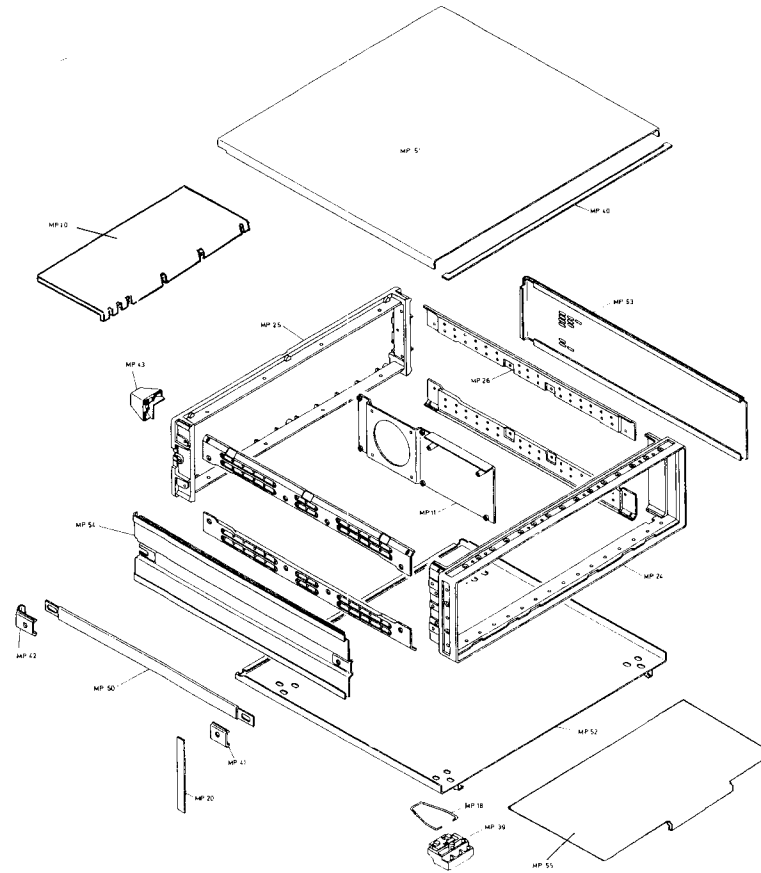
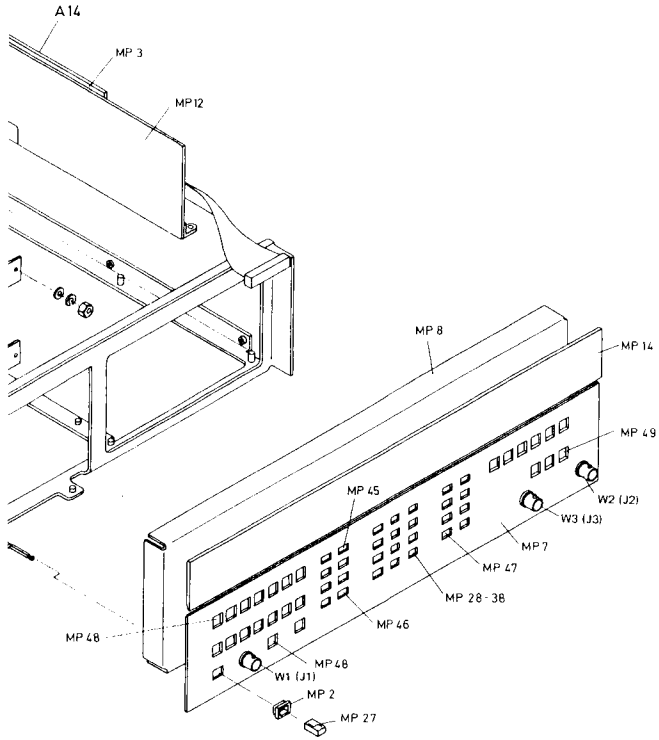

Table 6-3. Replaceable Parts

Reference Designation	HP Part Number	C D	Qty	Description	Mfr Code	Mfr Part Number
A1	08165-66501	4		BD AY KEY		
A2	08165-66502	5		BD AY DISPLAY		
A3	08165-66503	6		BD AY PRCR		
A4	08165-66504	7		BD AY OUT AMPL		
A5	08165-66505	8		BD AY TIMING		
A6	08165-66506	9		BD AY PWR CONT		
A7	08165-66507	0		BD AY INP MOD		
A8	08165-66508	1		BD AY VCO CONT		
A9	08165-66509	2		BD AY REF LOOP		
A10	08165-66510	5		BD AY LOW FREQ G		
A12	08165-66512	7		BD AY OFFSET GEN		
A14	08165-66514	9		BD AY HP-IB		
A15	08165-66515	0		BD AY-RAMP ADJ		
A16	08165-66516	1		BD AY-SOURCES AD		
A17	08165-66517	2		BD AY-APTD ADJ		
B1	3160-0209	4	1	FAN-TBAX 32-CFM 105-125V 50/60-HZ	23930	8500C
C1	0160-3731	0	2	CAPACITOR-FXD .01UF +-20% 1KVDC CER	28480	0160-3731
C2	0160-3731	0		CAPACITOR-FXD .01UF +-20% 1KVDC CER	28480	0160-3731
C3	0160-4084	8	1	CAPACITOR-FXD .1UF +-20% 50VDC CER	28480	0160-4084
CR1	1901-0496	1	2	DIODE-PWR RECT 100V 12A DO-4	04713	MR1121
CR2	1901-0496	1		DIODE-PWR RECT 100V 12A DO-4	04713	MR1121
FL1	9135-0035	1		FILTER LINE		
J4	1250-0118	3		CONNECTOR-RF BNC FEM 8GL-HOLE-FR 50-OHM	28480	1250-0118
J5	1250-0118	3		CONNECTOR-RF BNC FEM 8GL-HOLE-FR 50-OHM	28480	1250-0118
MP1	01830-23201	3	1	COUPLER, SWITCH 10-24	28480	01830-23201
MP2	0370-0914	0	1	BEZEL-PB KNOB, .490LG, .330W, .165HI, JADE	28480	0370-0914
MP3	0380-0599	8	1	SPACER-HEADED .125 ID, .439 DIA HD, .237	28480	0380-0599
MP4	0400-0077	1	1	GROMMET-RND .375-IN-ID .5-IN-GRV-OD	28480	0400-0077
MP5	0400-0193	2	1	GROMMET-SPCL .221-IN-ID	28480	0400-0193
MP6	2260-0009	3	1	NUT-HEX-W/LKWR 4-40-THD .094-IN-THK	00000	ORDER BY DESCRIPTION
MP7	08165-00207	4	1	PANEL FRONT	28480	08165-00207
MP8	08165-00208	5	1	PANEL, SUB	28480	08165-00208
MP10	08165-01201	5	1	BRACKET, PC BOARD	28480	08165-01201
MP11	08165-01202	6	1	BRACKET, FAN	28480	08165-01202
MP12	08165-01204	8	1	BRACKET, MP-IB BOARD	28480	08165-01204
MP13	08165-21101	6	1	HEAT SINK	28480	08165-21101
MP14	08165-28101	0	1	WINDOW	28480	08165-28101
MP15	08165-60101	8	1	CHASSIS ASSEMBLY	28480	08165-60101
MP16	08165-60201	9	1	PANEL ASSEMBLY, REAR	28480	08165-60201
MP17	1200-0080	3	1	INSULATOR-DIG ALUMINUM HD-ANDZ	28480	1200-0080
MP18	1460-1345	5	1	TILT STAND BST	28480	1460-1345
MP19	5000-8915	9	1	COVER, TRANSFORMER, OLIVE BLACK	28480	5000-8915
MP19	5040-6011	6	2		28480	5040-6011
MP20	5001-0439	8	1	TRIM, FRONT SIDE	28480	5001-0439
MP21	5001-1206	9	1	PLATE, SAFETY POWER	28480	5001-1206
MP22	5001-1207	0	1	INSULATOR, POWER SWITCH	28480	5001-1207
MP24	5020-8803	6	1	FRAME, FRONT	28480	5020-8803
MP25	5020-8804	7	1	FRAME, REAR	28480	5020-8804
MP26	5020-8836	5	1	CORNER STRUT 15	28480	5020-8836
MP27	5040-1124	2	1	KNOB, PUSHBUTTON, POWER	28480	5040-1124
MP28	5040-6010	5	1	KEY CAP, 0	28480	5040-6010
MP29	5040-6011	6	1	KEY CAP, 1	28480	5040-6011
MP30	5040-6012	7	1	KEY CAP, 2	28480	5040-6012
MP31	5040-6013	8	1	KEY CAP, 3	28480	5040-6013

Table 6-3. Replaceable Parts (cont'd)

Reference Designation	HP Part Number	C D	Qty	Description	Mfr Code	Mfr Part Number
MP32	5040-6014	9	1	KEY CAP, 4	28480	5040-6014
MP33	5040-6015	0	1	KEY CAP, 5	28480	5040-6015
MP34	5040-6016	1	1	KEY CAP, 6	28480	5040-6016
MP35	5040-6017	2	1	KEY CAP, 7	28480	5040-6017
MP36	5040-6018	3	1	KEY CAP, 8	28480	5040-6018
MP37	5040-6019	4	1	KEY CAP, 9	28480	5040-6019
MP38	5040-6020	7	1	KEY CAP, 0	28480	5040-6020
MP39	5040-7201	8	1	FOOT(STANDARD)	28480	5040-7201
MP40	5040-7202	9	1	TRIM, TOP	28480	5040-7202
MP41	5040-7219	8	1	STRAP, HANDLE, CAP-FRONT	28480	5040-7219
MP42	5040-7220	1	1	STRAP, HANDLE, CAP-REAR	28480	5040-7220
MP43	5040-7221	2	1		28480	5040-7221
MP44	5040-7756	8	1		28480	5040-7756
MP45	5040-9305	7	1	KEY, LARGE, OLIVE REIGE	28480	5040-9305
MP46	5040-9306	8	1	KEY, LARGE, OLIVE GREY	28480	5040-9306
MP47	5040-9307	9	1	KEY, LARGE, GOLD	28480	5040-9307
MP48	5041-0309	5	1	KEY CAP, QUARTER	28480	5041-0309
MP49	5041-0318	6	1	LOCK CAP, PTY GREY	28480	5041-0318
MP50	5060-9803	2	1		28480	5060-9803
MP51	5060-9834	9	1	COVER ASSY, TOP	28480	5060-9834
MP52	08170-64111	5	1	COVER ASSY, BOTTOM	28480	08170-64111
MP53	5060-9911	3	1	COVER, SIDE	28480	5060-9911
MP54	5060-9936	2	1	COVER, SIDE 15"	28480	5060-9936
MP55	9222-0608	5	1	COVER, OPERATION CARD	28480	9222-0608
MP56	08165-45201	7	1	HOUSING, LAMP	28480	08165-45201
MPE1	0340-1042		6	INSULATING WASHER		0340-1042
Q1	1853-0251	3	3	TRANSISTOR PNP SI PD=90W FT=2MHZ	28480	1853-0251
Q2	1854-0433	5	2	TRANSISTOR NPN SI PD=90W FT=2MHZ	28480	1854-0433
Q3	1853-0251	3		TRANSISTOR PNP SI PD=90W FT=2MHZ	28480	1853-0251
Q4	1854-0433	5		TRANSISTOR NPN SI PD=90W FT=2MHZ	28480	1854-0433
Q5	1853-0251	3		TRANSISTOR PNP SI PD=90W FT=2MHZ	28480	1853-0251
S2	3101-2298			SWITSCH SLIDE		
S3	3101-2298			SWITSCH SLIDE		
S4	3101-0070			SWITSCH SLIDE OPDT		
S1	3101-2216	2	1	SWITCH PSTN	28480	3101-1720
T1	08165-61101	0	1	TRANSFORMER, POWER	28480	08165-61101
W1	08165-61611		2	CBL AY EXT INPUT	28480	08165-61611
W2	08165-61612			CBL AY SIGN OUTPUT	28480	08165-61612
W3	08165-61613			CBL AY SYNC OUTPUT	28480	08165-61613
W5	01865-61605			CBL AY CONTROL CURRENT	28480	08165-61605
X10	08165-61601	5	2	CABLE ASSEMBLY, COAX	28480	08165-61601
X11	08165-61601	5		CABLE ASSEMBLY, COAX	28480	08165-61601
X12	A120-1692	2	1	CABLE ASSY 3-CNDCT MGP-JKT	28480	A120-1692
XF1C	2110-0569			NUT HEX		
XF1A	2110-0565			FUSEHOLDER CAP		
XF1B	2110-0564			FUSEHOLDER BODY		
XF1E	1400-0090			WASHER NEOPRENE		

Table 6-3. Replaceable Parts (cont'd)

Reference Designation	HP Part Number	C D	Qty	Description	Mfr Code	Mfr Part Number
A1	08165-66501	4	1	BOARD ASSEMBLY, KEY	28480	08165-66501
A1W9	50P1-1962	2	1	CABLE, RIBBON 14C 330MM	28480	50P1-1962
A2	08165-66502	5	1	BOARD ASSEMBLY, DISPLAY	28480	08165-66502
A2C1	0160-0174	9	54	CAPACITOR-FXD .47UF +80-20X 25VDC CER	28480	0160-0174
A2C2	0160-0174	9		CAPACITOR-FXD .47UF +80-20X 25VDC CER	28480	0160-0174
A2C3	01A0-1704	5	11	CAPACITOR-FXD 47UF+-10% 6VDC TA	56289	150D476X900662
A2C4	01A0-1704	5		CAPACITOR-FXD 47UF+-10% 6VDC TA	56289	150D476X900662
A2D51	1990-0487	7	21	LED-VISIBLE LUM-INT=1MCD IF=20MA-MAX	28480	5082-4584
A2D52	1990-0487	7		LED-VISIBLE LUM-INT=1MCD IF=20MA-MAX	28480	5082-4584
A2D53	1990-0487	7		LED-VISIBLE LUM-INT=1MCD IF=20MA-MAX	28480	5082-4584
A2D54	1990-0487	7		LED-VISIBLE LUM-INT=1MCD IF=20MA-MAX	28480	5082-4584
A2D55	1990-0487	7		LED-VISIBLE LUM-INT=1MCD IF=20MA-MAX	28480	5082-4584
A2D56	1990-0487	7		LED-VISIBLE LUM-INT=1MCD IF=20MA-MAX	28480	5082-4584
A2D57	1990-0487	7		LED-VISIBLE LUM-INT=1MCD IF=20MA-MAX	28480	5082-4584
A2DS10 to 20	1990-0670	7		LED VISIBLE YEL		
A2DS29,30,31	1990-0670	7		LED VISIBLE YEL	28480	5082-4584
A2D532	1990-0485	5	1	LED-VISIBLE LUM-INT=800UCD IF=30MA-MAX	28480	5082-4984
A2D533	2140-0016	8	7	LAMP-INCAND 683 5VDC 60MA T-1-BULB	0000J	683
A2D534	2140-0016	8		LAMP-INCAND 683 5VDC 60MA T-1-BULB	0000J	683
A2D535	2140-0016	8		LAMP-INCAND 683 5VDC 60MA T-1-BULB	0000J	683
A2D536	2140-0016	8		LAMP-INCAND 683 5VDC 60MA T-1-BULB	0000J	683
A2D541	2140-0016	8		LAMP-INCAND 683 5VDC 60MA T-1-BULB	0000J	683
A2D542	2140-0016	8		LAMP-INCAND 683 5VDC 60MA T-1-BULB	0000J	683
A2D543	2140-0016	8		LAMP-INCAND 683 5VDC 60MA T-1-BULB	0000J	683
A2D551	1990-0452	6	12	DISPLAY-NUM-SEG 1-CHAR .3-H	28480	5082-7731, CAT C-E
A2D552	1990-0452	6		DISPLAY-NUM-SEG 1-CHAR .3-H	28480	5082-7731, CAT C-E
A2D553	1990-0452	6		DISPLAY-NUM-SEG 1-CHAR .3-H	28480	5082-7731, CAT C-E
A2D554	1990-0452	6		DISPLAY-NUM-SEG 1-CHAR .3-H	28480	5082-7731, CAT C-E
A2D555	1990-0452	6		DISPLAY-NUM-SEG 1-CHAR .3-H	28480	5082-7731, CAT C-E
A2D556	1990-0452	6		DISPLAY-NUM-SEG 1-CHAR .3-H	28480	5082-7731, CAT C-E
A2D557	1990-0452	6		DISPLAY-NUM-SEG 1-CHAR .3-H	28480	5082-7731, CAT C-E
A2D558	1990-0452	6		DISPLAY-NUM-SEG 1-CHAR .3-H	28480	5082-7731, CAT C-E
A2D559	1990-0452	6		DISPLAY-NUM-SEG 1-CHAR .3-H	28480	5082-7731, CAT C-E
A2D560	1990-0452	6		DISPLAY-NUM-SEG 1-CHAR .3-H	28480	5082-7731, CAT C-E
A2D561	1990-0452	6		DISPLAY-NUM-SEG 1-CHAR .3-H	28480	5082-7731, CAT C-E
A2D562	1990-0452	6		DISPLAY-NUM-SEG 1-CHAR .3-H	28480	5082-7731, CAT C-E
A2J4	1200-0589	7	12	SOCKET-IC 14-CONT DIP-SLDR	28480	1200-0589
A2J5	1200-0589	7		SOCKET-IC 14-CONT DIP-SLDR	28480	1200-0589
A2J6	1200-0589	7		SOCKET-IC 14-CONT DIP-SLDR	28480	1200-0589
A2J7	1200-0589	7		SOCKET-IC 14-CONT DIP-SLDR	28480	1200-0589
A2J8	1200-0589	7		SOCKET-IC 14-CONT DIP-SLDR	28480	1200-0589
A2J9	1200-0589	7		SOCKET-IC 14-CONT DIP-SLDR	28480	1200-0589
A2J10	1200-0589	7		SOCKET-IC 14-CONT DIP-SLDR	28480	1200-0589
A2J11	1200-0589	7		SOCKET-IC 14-CONT DIP-SLDR	28480	1200-0589
A2J12	1200-0589	7		SOCKET-IC 14-CONT DIP-SLDR	28480	1200-0589
A2J13	1200-0589	7		SOCKET-IC 14-CONT DIP-SLDR	28480	1200-0589
A2J14	1200-0589	7		SOCKET-IC 14-CONT DIP-SLDR	28480	1200-0589
A2J15	1200-0589	7		SOCKET-IC 14-CONT DIP-SLDR	28480	1200-0589
A2Q1	1854-0215	1	54	TRANSISTOR NPN 8I PD=350MW FT=300MHZ	04713	2N3904
A2Q2	1854-0215	1		TRANSISTOR NPN 8I PD=350MW FT=300MHZ	04713	2N3904
A2Q3	1854-0215	1		TRANSISTOR NPN 8I PD=350MW FT=300MHZ	04713	2N3904
A2Q4	1854-0215	1		TRANSISTOR NPN 8I PD=350MW FT=300MHZ	04713	2N3904
A2Q5	1854-0477	1	11	TRANSISTOR NPN 2N2222A 8I TO-18 PD=500MW	04713	2N2222A
A2Q6	1854-0477	7		TRANSISTOR NPN 2N2222A 8I TO-18 PD=500MW	04713	2N2222A
A2P1	0757-0706	A	9	RESISTOR 51.1 1% .25W F TC=0+-100	24546	C5=1/4-T0=51R1-F
A2P2	0757-0706	8		RESISTOR 51.1 1% .25W F TC=0+-100	24546	C5=1/4-T0=51R1-F
A2P3	0757-0706	8		RESISTOR 51.1 1% .25W F TC=0+-100	24546	C5=1/4-T0=51R1-F
A2P4	0757-0706	A		RESISTOR 51.1 1% .25W F TC=0+-100	24546	C5=1/4-T0=51R1-F
A2P5	0757-0280	3	7A	RESISTOR 1K 1% .125W F TC=0+-100	24546	C4=1/8-T0=1001-F

Table 6-3. Replaceable Parts (cont'd)

Reference Designation	HP Part Number	C D	Qty	Description	Mfr Code	Mfr Part Number
A2P6	0757-0280	3		RESISTOR 1K 1% .125W F TC=0+-100	24546	C4=1/B=T0=1001-F
A2P7	0757-0280	3		RESISTOR 1K 1% .125W F TC=0+-100	24546	C4=1/B=T0=1001-F
A2R8	0757-0280	3		RESISTOR 1K 1% .125W F TC=0+-100	24546	C4=1/B=T0=1001-F
A2R9	0757-0280	3		RESISTOR 1K 1% .125W F TC=0+-100	24546	C4=1/B=T0=1001-F
A2R10	0757-0280	3		RESISTOR 1K 1% .125W F TC=0+-100	24546	C4=1/B=T0=1001-F
A2R11	0757-0281	4	4	RESISTOR 2,74K 1% .125W F TC=0+-100	24546	C4=1/B=T0=2741-F
A2R12	0757-0281	4		RESISTOR 2,74K 1% .125W F TC=0+-100	24546	C4=1/B=T0=2741-F
A2R13	0757-0281	4		RESISTOR 2,74K 1% .125W F TC=0+-100	24546	C4=1/B=T0=2741-F
A2R14	0757-0281	4		RESISTOR 2,74K 1% .125W F TC=0+-100	24546	C4=1/B=T0=2741-F
A2R15	069A-3155	1	11	RESISTOR 4,64K 1% .125W F TC=0+-100	24546	C4=1/B=T0=4641-F
A2R16	069A-3155	1		RESISTOR 4,64K 1% .125W F TC=0+-100	24546	C4=1/B=T0=4641-F
A2R17	0757-0417	8	4	RESISTOR 562 1% .125W F TC=0+-100	24546	C4=1/B=T0=562R-F
A2R18	1810-0162	5	1	NETWORK-RES 14-DIP4,7K OHM X 13	11236	760-1-R4,7K
A2R19	R159-0005	0	3	WIRE 22AWG W PVC 1X22 80C	28480	R159-0005
A2R20	R159-0005	0		WIRE 22AWG W PVC 1X22 80C	28480	R159-0005
A2P21	R159-0005	0		WIRE 22AWG W PVC 1X22 80C	28480	R159-0005
A281	5060-9436	7	17	PUSHBUTTON SWITCH P.C. MOUNT	28480	5060-9436
A282	5060-9436	7		PUSHBUTTON SWITCH P.C. MOUNT	28480	5060-9436
A283	5060-9436	7		PUSHBUTTON SWITCH P.C. MOUNT	28480	5060-9436
A284	5060-9436	7		PUSHBUTTON SWITCH P.C. MOUNT	28480	5060-9436
A285	5060-9436	7		PUSHBUTTON SWITCH P.C. MOUNT	28480	5060-9436
A286	5060-9436	7		PUSHBUTTON SWITCH P.C. MOUNT	28480	5060-9436
A287	5060-9436	7		PUSHBUTTON SWITCH P.C. MOUNT	28480	5060-9436
A288	5060-9436	7		PUSHBUTTON SWITCH P.C. MOUNT	28480	5060-9436
A289	5060-9436	7		PUSHBUTTON SWITCH P.C. MOUNT	28480	5060-9436
A2810	5060-9436	7		PUSHBUTTON SWITCH P.C. MOUNT	28480	5060-9436
A2811	5060-9436	7		PUSHBUTTON SWITCH P.C. MOUNT	28480	5060-9436
A2812	5060-9436	7		PUSHBUTTON SWITCH P.C. MOUNT	28480	5060-9436
A2814	5060-9436	7		PUSHBUTTON SWITCH P.C. MOUNT	28480	5060-9436
A2815	5060-9436	7		PUSHBUTTON SWITCH P.C. MOUNT	28480	5060-9436
A2824	5060-9436	7		PUSHBUTTON SWITCH P.C. MOUNT	28480	5060-9436
A2825	5060-9436	7		PUSHBUTTON SWITCH P.C. MOUNT	28480	5060-9436
A2826	5060-9436	7		PUSHBUTTON SWITCH P.C. MOUNT	28480	5060-9436
A2U1	1820-1200	5	1	IC INV TTL LS HEX	01295	8N74LS05N
A2U2	1820-0628	9	3	IC TTL 64-RIT RAM 60-NS 0-C	01295	8N7489N
A2U3	1820-0491	4	1	IC ODDP TTL BCD-T0-OEC 4-T0-10-LINE	01295	8N74145N
A2W1	5081-1980	4	2	CABLE, RIBBON ILC 279MM	28480	5081-1980
A2W2	5081-1980	4		CABLE, RIBBON ILC 279MM	28480	5081-1980
A2W3	5081-1981	5	1	CABLE, RIBBON 26C 305MM	28480	5081-1981
A3	08165-66523	6	1	BOARD ASSEMBLY, PROCESSOR	28480	0A165-66523
A3B71	1420-0574	6	2	BATTERY 1.2V .15A-HR NI-CD 8LDR-TAB	28480	1420-0574
A3B72	1420-0574	6		BATTERY 1.2V .15A-HR NI-CD 8LDR-TAB	28480	1420-0574
A3C1	0160-4299	7	2	CAPACITOR-FXD 2200PF +-20% 250VDC CER	56289	C067F251F222M922-COH
A3C2	0160-1715	8	2	CAPACITOR-FXD 150UF+-10% 6VDC TA	56289	150D157X9006R2
A3C3	0160-4212	4	7	CAPACITOR-FXD .068UF +-20% 50VDC POLYE	28480	0160-4212
A3C4	0160-4212	4		CAPACITOR-FXD .068UF +-20% 50VDC POLYE	28480	0160-4212
A3C5	0160-4212	4		CAPACITOR-FXD .068UF +-20% 50VDC POLYE	28480	0160-4212
A3C6	0160-0174	9		CAPACITOR-FXD .47UF +80-20% 25VDC CER	28480	0160-0174
A3C7	0180-1714	7	1	CAPACITOR-FXD 330UF+-10% 6VDC TA	56289	150D337X9006B2
A3C8	0180-1704	5		CAPACITOR-FXD 47UF+-10% 6VDC TA	56289	150D476X9006B2
A3C9	0180-0228	6	2	CAPACITOR-FXD 22UF+-10% 15VDC TA	56289	150D226X9015B2
A3C10	0160-0174	9		CAPACITOR-FXD .47UF +80-20% 25VDC CER	28480	0160-0174
A3C11	0180-1704	5		CAPACITOR-FXD 47UF+-10% 6VDC TA	56289	150D476X9006B2
A3C12	0180-0197	8	6	CAPACITOR-FXD 2,2UF+-10% 20VDC TA	56289	150D225X9020A2
A3C13	0160-2150	5	7	CAPACITOR-FXD 33PF +-5% 300VDC MICA	28480	0160-2150
A3C14	0160-2150	5		CAPACITOR-FXD 33PF +-5% 300VDC MICA	28480	0160-2150
A3C15	0160-2150	5		CAPACITOR-FXD 33PF +-5% 300VDC MICA	28480	0160-2150
A3C16	0140-0192	9	3	CAPACITOR-FXD 68PF +-5% 300VDC MICA	72136	DM15E680J0300VV1CR
A3C17	0160-2150	5		CAPACITOR-FXD 33PF +-5% 300VDC MICA	28480	0160-2150
A3C18	0140-0192	9		CAPACITOR-FXD 68PF +-5% 300VDC MICA	72136	DM15E680J0300VV1CR
A3C19	0160-2055	9	10	CAPACITOR-FXD .01UF +80-20% 100VDC CER	28480	0160-2055
A3C20	0160-0155	6	1	CAPACITOR-FXD 3300PF +-10% 200VDC POLYE	28480	0160-0155
A3C21	0160-4210	2	9	CAPACITOR-FXD .022UF +-20% 50VDC POLYE	28480	0160-4210
A3C22	0160-3724	1	1	CAPACITOR-FXD .47UF +-10% 40VDC	28480	0160-3724
A3C23	0160-3874	2	1	CAPACITOR-FXD 10PF +-5PF 200VDC CER	28480	0160-3874
A3CR1	1901-0050	3	20	DIODE-SWITCHING 80V 200MA 2NS DO-35	28480	1901-0050
A3CR2	1901-0050	3		DIODE-SWITCHING 80V 200MA 2NS DO-35	28480	1901-0050
A3CR3	1901-0050	3		DIODE-SWITCHING 80V 200MA 2NS DO-35	28480	1901-0050
A3CR4	1901-0050	3		DIODE-SWITCHING 80V 200MA 2NS DO-35	28480	1901-0050
A3CR5	1901-0050	3		DIODE-SWITCHING 80V 200MA 2NS DO-35	28480	1901-0050

Table 6-3. Replaceable Parts (cont'd)

Reference Designation	HP Part Number	C D	Qty	Description	Mfr Code	Mfr Part Number
A3J1	1251-3024	8	3	CONNECTOR 26-PIN M RECTANGULAR	28480	1251-3024
A3J2	1251-3024	8		CONNECTOR 26-PIN M RECTANGULAR	28480	1251-3024
A3J3	1251-3024	8		CONNECTOR 26-PIN M RECTANGULAR	28480	1251-3024
A3J4	1200-0548	8	1	SOCKET-IC 14-CONT DIP DIP-SLDR	28480	1200-0548
A3J5	1200-0654	2	1	SOCKET-IC 40-CONT DIP-SLDR	28480	1200-0659
A3MP1	08160-02301	3	1	PC BOARD HOLDER	28480	08160-02301
A3MP2	4040-0750	7	2	EXTR-PC BD RED POLYC .062-BD-TMKN8	28480	4040-0750
A3MP3	4040-0750	7		EXTR-PC BD RED POLYC .062-BD-TMKN8	28480	4040-0750
A3MP4	0340-0451	7	1	INSULATOR-XSTR MICA	28480	0340-0451
A3Q1	1854-0330	1	1	TRANSISTOR NPN SI PD=21W FT=10MHZ	28480	1854-0330
A3Q2	1854-0477	7		TRANSISTOR NPN 2N2222A SI TO-18 PD=500MW	04713	2N2222A
A3Q3	1853-0086	2	16	TRANSISTOR PNP SI PD=310MW FT=40MHZ	27014	2N5087
A3Q4	1853-0086	2		TRANSISTOR PNP SI PD=310MW FT=40MHZ	27014	2N5087
A3Q5	1854-0215	1		TRANSISTOR NPN SI PD=350MW FT=300MHZ	04713	2N3904
A3Q6	1853-0036	2	34	TRANSISTOR PNP SI PD=310MW FT=250MHZ	28480	1853-0036
A3Q7	1853-0086	2		TRANSISTOR PNP SI PD=310MW FT=40MHZ	27014	2N5087
A3Q8	1854-0392	5	8	TRANSISTOR NPN SI PD=310MW FT=50MHZ	04713	2N5088
A3Q9	1854-0215	1		TRANSISTOR NPN SI PD=350MW FT=300MHZ	04713	2N3904
A3Q10	1854-0215	1		TRANSISTOR NPN SI PD=350MW FT=300MHZ	04713	2N3904
A3Q11	1854-0215	1		TRANSISTOR NPN SI PD=350MW FT=300MHZ	04713	2N3904
A3Q12	1854-0215	1		TRANSISTOR NPN SI PD=350MW FT=300MHZ	04713	2N3904
A3R1	1810-0055	5	3	NETWORK-RES 9-SIP10,OK OHM X 8	28480	1810-0055
A3R2	0757-0442	0	40	RESISTOR 10K 1% .125W F TC=0+-100	24546	C4=1/8-T0=1002-F
A3R3	0757-0401	0	27	RESISTOR 100 1% .125W F TC=0+-100	24546	C4=1/8-T0=101-F
A3R4	0757-0412	3	1	RESISTOR 365 1% .125W F TC=0+-100	24546	C4=1/8-T0=365R-F
A3R5	0757-0417	8		RESISTOR 562 1% .125W F TC=0+-100	24546	C4=1/8-T0=562R-F
A3R6	0757-0706	8		RESISTOR 51.1K 1% .125W F TC=0+-100	24546	C5=1/4-T0=5111-F
A3R7	0757-0280	3		RESISTOR 1K 1% .125W F TC=0+-100	24546	C4=1/8-T0=1001-F
A3R8	0757-0438	3	22	RESISTOR 5.11K 1% .125W F TC=0+-100	24546	C4=1/8-T0=5111-F
A3R9	0698-4458	9	3	RESISTOR 590 1% .125W F TC=0+-100	24546	C4=1/8-T0=590R-F
A3R10	0698-3447	4	3	RESISTOR 422 1% .125W F TC=0+-100	24546	C4=1/8-T0=422R-F
A3R11	0757-0438	3		RESISTOR 5.11K 1% .125W F TC=0+-100	24546	C4=1/8-T0=5111-F
A3R12	0757-0439	4	16	RESISTOR 6.81K 1% .125W F TC=0+-100	24546	C4=1/8-T0=6811-F
A3R13	0757-0444	1	27	RESISTOR 12.1K 1% .125W F TC=0+-100	24546	C4=1/8-T0=1212-F
A3R14	0757-0458	7	14	RESISTOR 51.1K 1% .125W F TC=0+-100	24546	C4=1/8-T0=5112-F
A3R15	0698-3260	9	2	RESISTOR 464K 1% .125W F TC=0+-100	28480	0698-3260
A3R16	0757-0123	3	1	RESISTOR 34.8K 1% .125W F TC=0+-100	28480	0757-0123
A3R18	0757-0291	6	1	RESISTOR 24.9 1% .125W F TC=0+-100	19701	MF4C1/8-T0=2492-F
A3R19	0757-0280	3		RESISTOR 1K 1% .125W F TC=0+-100	24546	C4=1/8-T0=1001-F
A3R20	0757-0280	3		RESISTOR 1K 1% .125W F TC=0+-100	24546	C4=1/8-T0=1001-F
A3R21	0757-0401	0		RESISTOR 100 1% .125W F TC=0+-100	24546	C4=1/8-T0=101-F
A3R22	0757-0465	6	6	RESISTOR 100K 1% .125W F TC=0+-100	24546	C4=1/8-T0=1003-F
A3R23	0698-3447	4		RESISTOR 422 1% .125W F TC=0+-100	24546	C4=1/8-T0=422R-F
A3R24	0757-0465	6		RESISTOR 100K 1% .125W F TC=0+-100	24546	C4=1/8-T0=1003-F
A3R25	0698-4486	3	5	RESISTOR 24.9K 1% .125W F TC=0+-100	24546	C4=1/8-T0=2492-F
A3R26	0757-0283	6	11	RESISTOR 2K 1% .125W F TC=0+-100	24546	C4=1/8-T0=2001-F
A3R27	0698-4486	8		RESISTOR 24.9K 1% .125W F TC=0+-100	24546	C4=1/8-T0=2492-F
A3R28	0698-3178	3	8	RESISTOR 487 1% .125W F TC=0+-100	24546	C4=1/8-T0=487R-F
A3R29	0698-4444	3	6	RESISTOR 4.87K 1% .125W F TC=0+-100	24546	C4=1/8-T0=4871-F
A3R30	0757-0280	3		RESISTOR 1K 1% .125W F TC=0+-100	24546	C4=1/8-T0=1001-F
A3R31	0757-0442	9		RESISTOR 10K 1% .125W F TC=0+-100	24546	C4=1/8-T0=1002-F
A3R32	0698-4086	9	5	RESISTOR 22.6 1% .125W F TC=0+-100	03888	PME55=1/8-T0=22R6-F
A3R33	0757-0346	2	20	RESISTOR 10 1% .125W F TC=0+-100	24546	C4=1/8-T0=10R0-F
A3R34	0698-3178	8		RESISTOR 487 1% .125W F TC=0+-100	24546	C4=1/8-T0=487R-F
A3R35	0698-4444	3		RESISTOR 4.87K 1% .125W F TC=0+-100	24546	C4=1/8-T0=4871-F
A3R36	0757-0280	3		RESISTOR 1K 1% .125W F TC=0+-100	24546	C4=1/8-T0=1001-F
A3R37	0757-0442	9		RESISTOR 10K 1% .125W F TC=0+-100	24546	C4=1/8-T0=1002-F
A3R38	0698-4086	9		RESISTOR 22.6 1% .125W F TC=0+-100	03888	PME55=1/8-T0=22R6-F
A3R39	0757-0346	2		RESISTOR 10 1% .125W F TC=0+-100	24546	C4=1/8-T0=10R0-F
A3R41	0757-0349	5	12	RESISTOR 22.6K 1% .125W F TC=0+-100	24546	C4=1/8-T0=2262-F
A3R42	0757-0438	3		RESISTOR 5.11K 1% .125W F TC=0+-100	24546	C4=1/8-T0=5111-F
A3R43	0757-0283	6		RESISTOR 2K 1% .125W F TC=0+-100	24546	C4=1/8-T0=2001-F
A3R44	0757-0283	6		RESISTOR 2K 1% .125W F TC=0+-100	24546	C4=1/8-T0=2001-F
A3R45	1810-0055	5		NETWORK-RES 9-SIP10,OK OHM X 8	28480	1810-0055
A3R46	0757-0442	9		RESISTOR 10K 1% .125W F TC=0+-100	24546	C4=1/8-T0=1002-F
A3R47	0757-0442	9		RESISTOR 10K 1% .125W F TC=0+-100	24546	C4=1/8-T0=1002-F
A3R48	0757-0450	9	1	RESISTOR 22.1K 1% .125W F TC=0+-100	24546	C4=1/8-T0=2212-F
A3R50	0757-0442	9		RESISTOR 10K 1% .125W F TC=0+-100	24546	C4=1/8-T0=1002-F
A3R51	0757-0465	6		RESISTOR 100K 1% .125W F TC=0+-100	24546	C4=1/8-T0=1003-F
A3R52	0698-4460	3	6	RESISTOR 649 1% .125W F TC=0+-100	24546	C4=1/8-T0=649R-F
A3R53	0757-0472	5	1	RESISTOR 200K 1% .125W F TC=0+-100	24546	C4=1/8-T0=2003-F
A3R55	0698-4460	3		RESISTOR 649 1% .125W F TC=0+-100	24546	C4=1/8-T0=649R-F
A3R56	0698-4460	3		RESISTOR 649 1% .125W F TC=0+-100	24546	C4=1/8-T0=649R-F
A3R57	0698-4460	3		RESISTOR 649 1% .125W F TC=0+-100	24546	C4=1/8-T0=649R-F
A3R58	0698-4460	3		RESISTOR 649 1% .125W F TC=0+-100	24546	C4=1/8-T0=649R-F
A3R59	0698-4460	3		RESISTOR 649 1% .125W F TC=0+-100	24546	C4=1/8-T0=649R-F

Table 6-3. Replaceable Parts (cont'd)

Reference Designation	HP Part Number	C D	Qty	Description	Mfr Code	Mfr Part Number
A3R60	1810-0055	5		NETWORK-RES 9-SIP10.0K OHM X A	28480	1810-0055
A3R61	0757-0493	0	A	RESISTOR 15 1X .25W F TC=0+-100	19701	MF52C1/4-T0-15R0-F
A3R62	0757-0493	0		RESISTOR 15 1X .25W F TC=0+-100	19701	MF52C1/4-T0-15R0-F
A3R63	0757-0493	0		RESISTOR 15 1X .25W F TC=0+-100	19701	MF52C1/4-T0-15R0-F
A3R64	0757-0493	0		RESISTOR 15 1X .25W F TC=0+-100	19701	MF52C1/4-T0-15R0-F
A3R65	0757-0493	0		RESISTOR 15 1X .25W F TC=0+-100	19701	MF52C1/4-T0-15R0-F
A3R66	0757-0493	0		RESISTOR 15 1X .25W F TC=0+-100	19701	MF52C1/4-T0-15R0-F
A3R67	0757-0493	0		RESISTOR 15 1X .25W F TC=0+-100	19701	MF52C1/4-T0-15R0-F
A3R6A	0757-0493	0		RESISTOR 15 1X .25W F TC=0+-100	19701	MF52C1/4-T0-15R0-F
A3R70	1810-0041	9	3	NETWORK-RES 9-SIP2.7K OHM X B	28480	1810-0041
A3R71	0698-3439	4	13	RESISTOR 178 1X .125W F TC=0+-100	24546	C4-1/8-T0-178R-F
A3R72	0698-3439	4		RESISTOR 178 1X .125W F TC=0+-100	24546	C4-1/8-T0-178R-F
A3R73	0698-3439	4		RESISTOR 178 1X .125W F TC=0+-100	24546	C4-1/8-T0-178R-F
A3R74	0698-3439	4		RESISTOR 178 1X .125W F TC=0+-100	24546	C4-1/8-T0-178R-F
A3R75	0698-3439	4		RESISTOR 178 1X .125W F TC=0+-100	24546	C4-1/8-T0-178R-F
A3R76	0698-3439	4		RESISTOR 178 1X .125W F TC=0+-100	24546	C4-1/8-T0-178R-F
A3R77	0698-3439	4		RESISTOR 178 1X .125W F TC=0+-100	24546	C4-1/8-T0-178R-F
A3R78	0698-3439	4		RESISTOR 178 1X .125W F TC=0+-100	24546	C4-1/8-T0-178R-F
A3R79	1810-0041	9		NETWORK-RES 9-SIP2.7K OHM X B	28480	1810-0041
A3R80	1810-0041	9		NETWORK-RES 9-SIP2.7K OHM X B	28480	1810-0041
A3R81	0698-3439	4		RESISTOR 178 1X .125W F TC=0+-100	24546	C4-1/8-T0-178R-F
A3R82	0698-3439	4		RESISTOR 178 1X .125W F TC=0+-100	24546	C4-1/8-T0-178R-F
A3R83	0698-3439	4		RESISTOR 178 1X .125W F TC=0+-100	24546	C4-1/8-T0-178R-F
A3R84	0698-3439	4		RESISTOR 178 1X .125W F TC=0+-100	24546	C4-1/8-T0-178R-F
A3R87	0757-0442	9		RESISTOR 10K 1X .125W F TC=0+-100	24546	C4-1/8-T0-1002-F
A3R8A	0683-5645	7	1	RESISTOR 560K 5X .25W FC TC=+100/+900	01121	CR5645
A3R90	0757-0384	8	A	RESISTOR 20 1X .125W F TC=0+-100	19701	MF4C1/8-T0-20R0-F
A3R91	0757-0384	8		RESISTOR 20 1X .125W F TC=0+-100	19701	MF4C1/8-T0-20R0-F
A3R92	0757-0384	8		RESISTOR 20 1X .125W F TC=0+-100	19701	MF4C1/8-T0-20R0-F
A3R93	0757-0384	8		RESISTOR 20 1X .125W F TC=0+-100	19701	MF4C1/8-T0-20R0-F
A3R94	0757-0384	8		RESISTOR 20 1X .125W F TC=0+-100	19701	MF4C1/8-T0-20R0-F
A3R95	0757-0384	8		RESISTOR 20 1X .125W F TC=0+-100	19701	MF4C1/8-T0-20R0-F
A3R96	0757-0280	1		R-FXD 1K 1% .125W		
A3RT1	0837-0050	5	1	THERMISTOR DISC 1K-OHM TC=-.4%/C-DEG	28480	0837-0050
A3U1	1820-0491	6	1	IC 74145N	01295	SN74LS367AN
A3U2	1820-1217	4	1	IC MUXR/DATA-SEL TTL LS 8-T0-1-LINE	01295	SN74LS151N
A3U3	1820-1481	4	3	IC NMOS	04713	MC6821L
A3U4	1820-1201	6	2	IC GATE TTL LS AND QUAD 2-INP	01295	SN74LS08N
A3U5	1820-1201	6		IC GATE TTL LS AND QUAD 2-INP	01295	SN74LS08N
A3U6	1820-1445	0	A	IC LCH TTL LS 4-BIT	01295	SN74LS375N
A3U7	1820-1445	0		IC LCH TTL LS 4-BIT	01295	SN74LS375N
A3U8	1820-1445	0		IC LCH TTL LS 4-BIT	01295	SN74LS375N
A3U9	1820-1445	0		IC LCH TTL LS 4-BIT	01295	SN74LS375N
A3U10	1820-1445	0		IC LCH TTL LS 4-BIT	01295	SN74LS375N
A3U11	1820-1423	4	3	IC MV TTL LS MONOSTBL RETRIG DUAL	01295	SN74LS123N
A3U12	1820-1804	5	1	IC BFR NMOS CLOCK DRVR	04713	MP06842
A3U13	1820-1480	3	1	IC MICPROC NMOS 8-BIT	04713	MC6800L
A3U14	1820-1199	1	4	IC INV TTL LS HEX 1-INP	01295	SN74LS04N
A3U15	1820-1281	2	2	IC DCDR TTL LS 2-T0-4-LINE DUAL 2-INP	01295	SN74LS139N
A3U16	1820-1199	1		IC INV TTL LS HEX 1-INP	01295	SN74LS04N
A3U17	1820-1208	3	2	IC GATE TTL LS OR QUAD 2-INP	01295	SN74LS32N
A3U18	1820-1144	6	3	IC GATE TTL LS NOR QUAD 2-INP	01295	SN74LS02N
A3U19	1820-1425	6	1	IC SCHMITT-TRIG TTL LS NAND QUAD 2-INP	01295	SN74LS132N
A3U20	1818-0695			IC MEM CMOS 5101		
A3U21	1818-0695			IC MEM CMOS 5101		
A3U22	1818-0695			IC MEM CMOS 5101		
A3U24	1818-1348	3	1	IC MEM NMOS 32 K	04713	MC46832L PROGRAMMED
A3U25	1818-1347	4	1	IC MEM NMOS 32 K	04713	MC46832L PROGRAMMED
A3U27	1820-1423	4		IC MV TTL LS MONOSTBL RETRIG DUAL	01295	SN74LS123N
A3U28	1820-1746	4	3	IC BFR CMOS INV HEX	04713	MC14049UBCP
A3U29	1820-1199	1		IC INV TTL LS HEX 1-INP	01295	SN74LS04N
A3U30	1820-1266	3	1	IC BFR CMOS NON-INV HEX	07263	40097PC
A3U31	1820-1144	6		IC GATE TTL LS NOR QUAD 2-INP	01295	SN74LS02N
A3U32	1820-1194	6	1	IC CNTR TTL LS BIN UP/DOWN SYNCHRD	01295	SN74LS193N
A3U33	1820-1418	7	1	IC DCDR TTL LS BCD-T0-DEC 4-T0-10-LINE	01295	SN74LS42N
A3U34	1820-1746	4		IC BFR CMOS INV HEX	04713	MC14049UBCP
A3U35	1820-1197	9	13	IC GATE TTL LS NAND QUAD 2-INP	01295	SN74LS00N
A3U36	1820-0628	9		IC TTL 64-BIT RAM 60-NS 0-C	01295	SN7489N
A3U37	1820-0628	9		IC TTL 64-BIT RAM 60-NS 0-C	01295	SN7489N
A3U3A	1820-1644	1	1	IC DCDR TTL LS BCD-T0-7-SEG 4-T0-7-LINE	01295	SN74LS248N
A3U39	1858-0023	7	1	TRANSISTOR ARRAY	01928	CA3081E
A3U40	1820-0495	8	1	IC DCDR TTL 4-T0-16-LINE 4-INP	01295	SN74154N

Table 6-3. Replaceable Parts (cont'd)

Reference Designation	HP Part Number	C D	Qty	Description	Mfr Code	Mfr Part Number
A3U41	185A-0014	6	3	TRANSISTOR ARRAY	28480	185A-0014
A3U42	185A-0014	6		TRANSISTOR ARRAY	28480	185A-0014
A3U43	185A-0014	6		TRANSISTOR ARRAY	28480	185A-0014
A3U44	1820-1445	0		IC LCH TTL LS 4-BIT	01295	SN74LS375N
A3U45	1820-1445	0		IC LCH TTL LS 4-BIT	01295	SN74LS375N
A3U46	1820-1445	0		IC LCH TTL LS 4-BIT	01295	SN74LS375N
A3U47	1820-1197	9		IC GATE TTL LS NAND QUAD 2-INP	01295	SN74LS00N
A3U48	1820-1281	2		IC OCDR TTL LS 2-TO-4-LINE DUAL 2-INP	01295	SN74LS139N
A3U49	1820-1451	8	6	IC GATE TTL S NAND QUAD 2-INP	01295	SN74S38N
A3U50	1820-1451	8		IC GATE TTL S NAND QUAD 2-INP	01295	SN74S38N
A3U51	1820-1197	9		IC GATE TTL LS NAND QUAD 2-INP	01295	SN74LS00N
A3U52	1820-1197	9		IC GATE TTL LS NAND QUAD 2-INP	01295	SN74LS00N
A3U53	1820-1197	9		IC GATE TTL LS NAND QUAD 2-INP	01295	SN74LS00N
A3U54	1820-1451	8		IC GATE TTL S NAND QUAD 2-INP	01295	SN74S38N
A3U55	1820-1451	8		IC GATE TTL S NAND QUAD 2-INP	01295	SN74S38N
A3U56	1820-1451	8		IC GATE TTL S NAND QUAD 2-INP	01295	SN74S38N
A3VR1	1902-3188	6	3	DIODE-ZNR 12.7V 2% DO-7 PDM.4W TC*+.061%	28480	1902-3188
A3VR2	1902-0048	1	3	DIODE-ZNR 6.81V 5% DO-7 PDM.4W TC*+.043%	28480	1902-0048
A4	08165-66504	7	1	BOARD ASSEMBLY, OUTPUT AMPLIFIER	28480	08165-66504
A4C1	0180-2837	7	1	CAPACITOR-FXD .032F+75-10% 20VDC AL	28480	0180-2837
A4C2	0180-2240	6	1	CAPACITOR-FXD 2400UF+75-10% 25VDC AL	56289	3902486025JL6-D88
A4C3	0180-0677	9	2	CAPACITOR-FXD 5800UF+75-10% 40VDC AL	28480	0180-0677
A4C4	0180-0677	9		CAPACITOR-FXD 5800UF+75-10% 40VDC AL	28480	0180-0677
A4C5	0160-3731	0	4	CAPACITOR-FXD .01UF +-20% 1KVDC CER	28480	0160-3731
A4C6	0160-3731	0		CAPACITOR-FXD .01UF +-20% 1KVDC CER	28480	0160-3731
A4C7	0160-3731	0		CAPACITOR-FXD .01UF +-20% 1KVDC CER	28480	0160-3731
A4C8	0160-3731	0		CAPACITOR-FXD .01UF +-20% 1KVDC CER	28480	0160-3731
A4C9	0160-3731	0		CAPACITOR-FXD .01UF +-20% 1KVDC CER	28480	0160-3731
A4C10	0160-3731	0		CAPACITOR-FXD .01UF +-20% 1KVDC CER	28480	0160-3731
A4C11	0180-0228	6		CAPACITOR-FXD 22UF+-10% 15VDC TA	56289	150D226x901582
A4C101	0160-3879	7	40	CAPACITOR-FXD .01UF +-20% 100VDC CER	28480	0160-3879
A4C102	0160-3879	7		CAPACITOR-FXD .01UF +-20% 100VDC CER	28480	0160-3879
A4C103	0160-2306	3	1	CAPACITOR-FXD 27PF +-5% 300VDC MICA	28480	0160-2306
A4C104	0160-0576	2	2	CAPACITOR-FXD 4700PF +-20% 100VDC CER	28480	0160-0576
A4C105	0160-0134	1	2	CAPACITOR-FXD 220PF +-5% 300VDC MICA	28480	0160-0134
A4C106	0121-0475	1	4	CAPACITOR-V TRMR-POLYP 2-22PF 100V	02540	2222 808 11229
A4C107	0160-0174	9		CAPACITOR-FXD .47UF +80-20% 25VDC CER	28480	0160-0174
A4C109	0160-0570	5	2	CAPACITOR-FXD 220PF +-20% 100VDC CER	20932	5024EM100RD221M
A4C110	0160-0576	5	20	CAPACITOR-FXD .1UF +-20% 50VDC CER	28480	0160-0576
A4C111	0160-0174	9		CAPACITOR-FXD .47UF +80-20% 25VDC CER	28480	0160-0174
A4C112	0160-0174	9		CAPACITOR-FXD .47UF +80-20% 25VDC CER	28480	0160-0174
A4C113	0160-3879	7		CAPACITOR-FXD .01UF +-20% 100VDC CER	28480	0160-3879
A4C114	0160-3879	7		CAPACITOR-FXD .01UF +-20% 100VDC CER	28480	0160-3879
A4C115	0160-0576	5		CAPACITOR-FXD .1UF +-20% 50VDC CER	28480	0160-0576
A4C117	0160-3873	1	4	CAPACITOR-FXD 4.7PF +-5PF 200VDC CER	28480	0160-3873
A4C118	0160-0576	5		CAPACITOR-FXD .1UF +-20% 50VDC CER	28480	0160-0576
A4C119*	0160-3872	0	1	CAPACITOR-FXD 2.2PF +-25PF 200VDC CER	28480	0160-3872
A4C120	0160-3873	1		CAPACITOR-FXD 4.7PF +-5PF 200VDC CER	28480	0160-3873
A4C121	0160-3878	6	9	CAPACITOR-FXD 1000PF +-20% 100VDC CER	28480	0160-3878
A4C122	0160-3878	0	1	CAPACITOR-FXD .001UF +-20% 100VDC CER	28480	0160-3878
A4C123	0160-0127	2	1	CAPACITOR-FXD 1UF +-20% 25VDC CER	28480	0160-0127
A4C124	0180-4386	3	1	CAPACITOR-FXD 33PF +-5% 200VDC CER 0+-30	51642	200-200-NP0-330J
A4C125	0160-3878	3		CAPACITOR-FXD 1000PF +-20% 100VDC CER	28480	0160-3878
A4C201	0160-0576	5	4	CAPACITOR-FXD .1UF +-20% 50VDC CER	28480	0160-0576
A4C202	0160-0128	3		CAPACITOR-FXD 2.2UF +-20% 50VDC CER	28480	0160-0128
A4C203	0180-1704	5		CAPACITOR-FXD 47UF+-10% 6VDC TA	56289	150D476x900682
A4C204	0160-3879	7		CAPACITOR-FXD .01UF +-20% 100VDC CER	28480	0160-3879
A4C205	0160-3879	7		CAPACITOR-FXD .01UF +-20% 100VDC CER	28480	0160-3879
A4C206	0160-0174	9		CAPACITOR-FXD .47UF +80-20% 25VDC CER	28480	0160-0174
A4C207	0160-3879	7		CAPACITOR-FXD .01UF +-20% 100VDC CER	28480	0160-3879
A4C208	0160-0576	5		CAPACITOR-FXD .1UF +-20% 50VDC CER	28480	0160-0576
A4C209	0160-0128	3		CAPACITOR-FXD 2.2UF +-20% 50VDC CER	28480	0160-0128
A4C210	0180-1704	5		CAPACITOR-FXD 47UF+-10% 6VDC TA	56289	150D476x900682
A4C211	0160-3879	7		CAPACITOR-FXD .01UF +-20% 100VDC CER	28480	0160-3879
A4C212	0160-4210	2		CAPACITOR-FXD .022UF +-20% 50VDC POLYE	28480	0160-4210
A4C213	0160-3879	7		CAPACITOR-FXD .01UF +-20% 100VDC CER	28480	0160-3879
A4C214	0160-0174	9		CAPACITOR-FXD .47UF +80-20% 25VDC CER	28480	0160-0174
A4C301	0160-3879	7		CAPACITOR-FXD .01UF +-20% 100VDC CER	28480	0160-3879
A4C302	0160-0575	4	1	CAPACITOR-FXD .047UF +-20% 50VDC CER	28480	0160-0575
A4C303	0160-3879	7		CAPACITOR-FXD .01UF +-20% 100VDC CER	28480	0160-3879
A4C304	0160-3879	7		CAPACITOR-FXD .01UF +-20% 100VDC CER	28480	0160-3879
A4C305	0160-3879	7		CAPACITOR-FXD .01UF +-20% 100VDC CER	28480	0160-3879
A4C501	0160-0576	5		CAPACITOR-FXD .1UF +-20% 50VDC CER	28480	0160-0576
A4C502	0160-3879	7		CAPACITOR-FXD .01UF +-20% 100VDC CER	28480	0160-3879
A4C503	0160-3879	7		CAPACITOR-FXD .01UF +-20% 100VDC CER	28480	0160-3879

Table 6-3. Replaceable Parts (cont'd)

Reference Designation	HP Part Number	C D	Qty	Description	Mfr Code	Mfr Part Number
A4C504	0180-1743	2	1	CAPACITOR-FXD .01UF+-10% 35VDC TA	56289	150D104X9035A2
A4C505	0180-0197	8		CAPACITOR-FXD 2.2UF+-10% 20VDC TA	56289	150D225X9020A2
A4C506	0160-4209	9	16	CAPACITOR-FXD .01UF +-20% 50VDC POLYE	28480	0160-4209
A4C50A	0160-4209	9		CAPACITOR-FXD .01UF +-20% 50VDC POLYE	28480	0160-4209
A4C509	0160-3879	7		CAPACITOR-FXD .01UF +-20% 100VDC CER	28480	0160-3879
A4C510	0160-4209	9		CAPACITOR-FXD .01UF +-20% 50VDC POLYE	28480	0160-4209
A4C511	0121-0475	1		CAPACITOR-V TRMR-POLYP 2-22PF 100V	02540	2222 808 11229
A4C512	0121-0475	1		CAPACITOR-V TRMR-POLYP 2-22PF 100V	02540	2222 808 11229
A4C513	0121-0475	1		CAPACITOR-V TRMR-POLYP 2-22PF 100V	02540	2222 808 11229
A4C514	0160-4385	1		CAPACITOR-FXD 15PF 200VDC		0160-4385
A4CR1	1901-0731	7	5	DIODE-PWR RECT 400V 1A	28480	1901-0731
A4CR2	1901-0731	7		DIODE-PWR RECT 400V 1A	28480	1901-0731
A4CR3	1901-0522	4	4	DIODE-GEN PRP 200V 3A 2US	28480	1901-0522
A4CR4	1901-0522	4		DIODE-GEN PRP 200V 3A 2US	28480	1901-0522
A4CR5	1901-0522	4		DIODE-GEN PRP 200V 3A 2US	28480	1901-0522
A4CR6	1901-0522	4		DIODE-GEN PRP 200V 3A 2US	28480	1901-0522
A4CR7	1901-0731	7		DIODE-PWR RECT 400V 1A	28480	1901-0731
A4CR8	1901-0731	7		DIODE-PWR RECT 400V 1A	28480	1901-0731
A4CR101	1901-0460	9	3	DIODE-STABILISOR 30V 150MA DO-7	28480	1901-0460
A4CR201	1901-0050	3		DIODE-SWITCHING 80V 200MA 2NS DO-35	28480	1901-0050
A4CR203	1901-0620	3	2	DIODE-SWITCHING 60V 400MA DO-35	0004G	NDP250
A4CR204	1901-0050	3		DIODE-SWITCHING 80V 200MA 2NS DO-35	28480	1901-0050
A4CR206	1901-0620	3		DIODE-SWITCHING 60V 400MA DO-35	0004G	NDP250
A4CR301	1901-0050	3		DIODE-SWITCHING 80V 200MA 2NS DO-35	28480	1901-0050
A4CR302	1901-0460	9		DIODE-STABILISOR 30V 150MA DO-7	28480	1901-0460
A4CR304	1901-0050	3		DIODE-SWITCHING 80V 200MA 2NS DO-35	28480	1901-0050
A4CR305	1901-0460	9		DIODE-STABILISOR 30V 150MA DO-7	28480	1901-0460
A4CR501	1901-0040	1	5A	DIODE-SWITCHING 30V 50MA 2NS DO-35	28480	1901-0040
A4CR502	1901-0040	1		DIODE-SWITCHING 30V 50MA 2NS DO-35	28480	1901-0040
A4CR503	1901-0040	1		DIODE-SWITCHING 30V 50MA 2NS DO-35	28480	1901-0040
A4CR504	1901-0040	1		DIODE-SWITCHING 30V 50MA 2NS DO-35	28480	1901-0040
A4CR505	1901-0040	1		DIODE-SWITCHING 30V 50MA 2NS DO-35	28480	1901-0040
A4CR506	1901-0040	1		DIODE-SWITCHING 30V 50MA 2NS DO-35	28480	1901-0040
A4J1	1200-0814	1	5	SOCKET-XSTR 3-CONT DIP-SLDR	28480	1200-0814
A4J2	1200-0814	1		SOCKET-XSTR 3-CONT DIP-SLDR	28480	1200-0814
A4J3	1200-0814	1		SOCKET-XSTR 3-CONT DIP-SLDR	28480	1200-0814
A4J4	1200-0814	1		SOCKET-XSTR 3-CONT DIP-SLDR	28480	1200-0814
A4J5	1200-0814	1		SOCKET-XSTR 3-CONT DIP-SLDR	28480	1200-0814
A4J7	1251-3785	8	1	CONNECTOR 20-PIN F METRIC CIS	28480	1251-3785
A4J8	1251-3708	5	1	CONNECTOR 10-PIN F METRIC CIS	28480	1251-3708
A4J9	1251-1365	6	1	CONNECTOR-PC EDGE 22-CONT/ROW 2-ROWS	28480	1251-1365
A4J10	1251-1626	2	1	CONNECTOR-PC EDGE 12-CONT/ROW 2-ROWS	28480	1251-1626
A4J12	1251-0472	4	1	CONNECTOR-PC EDGE 6-CONT/ROW 2-ROWS	28480	1251-0472
A4K101	0490-1034	1	2	RELAY 2C 12VDC-COIL .5A 350VDC	28480	0490-1034
A4K102	0490-1079	4	14	RELAY-REED 1A 500MA 100VDC 5VDC-COIL	28480	0490-1079
A4K401	0490-1079	4		RELAY-REED 1A 500MA 100VDC 5VDC-COIL	28480	0490-1079
A4K402	0490-1079	4		RELAY-REED 1A 500MA 100VDC 5VDC-COIL	28480	0490-1079
A4K403	0490-1079	4		RELAY-REED 1A 500MA 100VDC 5VDC-COIL	28480	0490-1079
A4K404	0490-0617	4	3	RELAY-REED 1C 250MA 28VDC 5VDC-COIL	28480	0490-0617
A4K405	0490-1034	1		RELAY 2C 12VDC-COIL .5A 350VDC	28480	0490-1034
A4L101	5081-1973	5	10	INDUCTANCE, 3-BEAD	28480	5081-1973
A4L102	5081-1973	5		INDUCTANCE, 3-BEAD	28480	5081-1973
A4L103	5081-1973	5		INDUCTANCE, 3-BEAD	28480	5081-1973
A4L104	9170-0029	3	16	CORE-SHIELDING BEAD	28480	9170-0029
A4L201	5081-1973	5		INDUCTANCE, 3-BEAD	28480	5081-1973
A4L202	5081-1973	5		INDUCTANCE, 3-BEAD	28480	5081-1973
A4L203	9170-0029	3		CORE-SHIELDING BEAD	28480	9170-0029
A4L204	9170-0029	3		CORE-SHIELDING BEAD	28480	9170-0029
A4L205	9170-0029	3		CORE-SHIELDING BEAD	28480	9170-0029
A4L206	9170-0029	3		CORE-SHIELDING BEAD	28480	9170-0029
A4L301	5081-1973	5		INDUCTANCE, 3-BEAD	28480	5081-1973
A4L302	5081-1973	5		INDUCTANCE, 3-BEAD	28480	5081-1973
A4MP1	08165-03201	9	1	COUPLER, THERMAL	28480	08165-03201
A4MP2	08165-01101	4	1	HEAT SINK, OUTPUT AMPLIFIER	28480	08165-01101
A4MP3	1205-0425	1	1	HEAT SINK	28480	1205-0425
A4MP4	08165-00602	8	1	SHIELD, ATTENUATOR	28480	08165-00602
A4Q101	1853-0315	0	6	TRANSISTOR PNP SI TO-39 PD=1W FT=1GHZ	28480	1853-0315
A4Q102	1853-0315	0		TRANSISTOR PNP SI TO-39 PD=1W FT=1GHZ	28480	1853-0315
A4Q103	1854-0477	7		TRANSISTOR NPN 2N2222A SI TO-18 PD=500MW	04713	2N2222A
A4Q104	1854-0477	7		TRANSISTOR NPN 2N2222A SI TO-18 PD=500MW	04713	2N2222A
A4Q105	1854-0477	7		TRANSISTOR NPN 2N2222A SI TO-18 PD=500MW	04713	2N2222A
A4Q106	1853-0086	2		TRANSISTOR PNP SI PD=310MW FT=40MHZ	27014	2N5087
A4Q107	5081-1978	0	2	TRANSISTOR, MATCHES PAIR	28480	5081-1978
A4Q108	5081-1978	0		TRANSISTOR, MATCHES PAIR	28480	5081-1978
A4Q111	1854-0368	0	1	TRANSISTOR NPN 2N5191 SI PD=40W FT=2MHZ	04713	2N5191
A4Q201	1854-0498	2	2	TRANSISTOR NPN SI TO-39 PD=1W	28480	1854-0498

Table 6-3. Replaceable Parts (cont'd)

Reference Designation	HP Part Number	C D	Qty	Description	Mfr Code	Mfr Part Number
A4Q202	1A53-0314	9	A	TRANSISTOR PNP 2N2905A SI TO-39 PD#600MW	04713	2N2905A
A4Q203	1A53-0315	0		TRANSISTOR PNP SI TO-39 PD#1W FT#1GHZ	28480	1A53-0315
A4Q204	1A53-0315	0		TRANSISTOR PNP SI TO-39 PD#1W FT#1GHZ	28480	1A53-0315
A4Q205	1A54-0637	1	7	TRANSISTOR NPN 2N2219A SI TO-5 PD#800MW	01295	2N2219A
A4Q206	1A54-0332	1	2	TRANSISTOR NPN SI TO-39 PD#1W FT#800MHZ	28480	1A54-0332
A4Q207	1A53-0281	9	9	TRANSISTOR PNP 2N2907A SI TO-18 PD#400MW	04713	2N2907A
A4Q208	1A54-0392	5		TRANSISTOR NPN SI PD#310MW FT#50MHZ	04713	2N5088
A4Q209	1A53-0036	2		TRANSISTOR PNP SI PD#310MW FT#250MHZ	28480	1A53-0036
A4Q210	1A54-0477	7		TRANSISTOR NPN 2N2222A SI TO-18 PD#500MW	04713	2N2222A
A4Q301	1A54-0498	2		TRANSISTOR NPN SI TO-39 PD#1W	28480	1A54-0498
A4Q302	1A53-0314	9		TRANSISTOR PNP 2N2905A SI TO-39 PD#600MW	04713	2N2905A
A4Q303	1A53-0315	0		TRANSISTOR PNP SI TO-39 PD#1W FT#1GHZ	28480	1A53-0315
A4Q304	1A53-0315	0		TRANSISTOR PNP SI TO-39 PD#1W FT#1GHZ	28480	1A53-0315
A4Q305	1A54-0637	1		TRANSISTOR NPN 2N2219A SI TO-5 PD#800MW	01295	2N2219A
A4Q306	1A54-0332	3		TRANSISTOR NPN SI TO-39 PD#1W FT#800MHZ	28480	1A54-0332
A4Q307	1A53-0314	9		TRANSISTOR PNP 2N2905A SI TO-39 PD#600MW	04713	2N2905A
A4Q308	1A54-0392	5		TRANSISTOR NPN SI PD#310MW FT#50MHZ	04713	2N5088
A4Q309	1A53-0036	2		TRANSISTOR PNP SI PD#310MW FT#250MHZ	28480	1A53-0036
A4Q310	1A54-0637	1		TRANSISTOR NPN 2N2219A SI TO-5 PD#800MW	01295	2N2219A
A4Q501	1A54-0215	1		TRANSISTOR NPN SI PD#350MW FT#300MHZ	04713	2N3904
A4Q502	1A53-0086	2		TRANSISTOR PNP SI PD#310MW FT#40MHZ	27014	2N5087
A4Q503	1A54-0392	5		TRANSISTOR NPN SI PD#310MW FT#50MHZ	04713	2N5088
A4Q504	1A54-0392	5		TRANSISTOR NPN SI PD#310MW FT#50MHZ	04713	2N5088
A4Q505	1A53-0086	2		TRANSISTOR PNP SI PD#310MW FT#40MHZ	27014	2N5087
A4Q506	1A53-0086	2		TRANSISTOR PNP SI PD#310MW FT#40MHZ	27014	2N5087
A4Q507	1A54-0215	1		TRANSISTOR NPN SI PD#350MW FT#300MHZ	04713	2N3904
A4Q508	1A53-0086	2		TRANSISTOR PNP SI PD#310MW FT#40MHZ	27014	2N5087
A4Q509	1A54-0215	1		TRANSISTOR NPN SI PD#350MW FT#300MHZ	04713	2N3904
A4Q510	1A54-0215	1		TRANSISTOR NPN SI PD#350MW FT#300MHZ	04713	2N3904
A4R1	0757-0706	8		RESISTOR 51.1 1% .25W F TC#0+-100	24546	C5=1/4-T0=51R1-F
A4R2	0811-1827	2	2	RESISTOR .1 10% 3W PW TC#0+-90	28480	0811-1827
A4R3	0757-0706	8		RESISTOR 51.1 1% .25W F TC#0+-100	24546	C5=1/4-T0=51R1-F
A4R4	0812-0040	1	1	RESISTOR .27 5% .5W PW TC#0+-300	75042	R#20-1/2-27/100-J
A4R5	0757-0407	6	21	RESISTOR 200 1% .125W F TC#0+-100	24546	C4=1/8-T0=201-F
A4R6	0812-0045	6	2	RESISTOR .15 5% 3W PW TC#0+-90	28480	0812-0045
A4R7	0757-0407	6		RESISTOR 200 1% .125W F TC#0+-100	24546	C4=1/8-T0=201-F
A4R8	0812-0045	6		RESISTOR .15 5% 3W PW TC#0+-90	28480	0812-0045
A4R9	0811-1827	2		RESISTOR .1 10% 3W PW TC#0+-90	28480	0811-1827
A4R10	0757-0407	6		RESISTOR 200 1% .125W F TC#0+-100	24546	C4=1/8-T0=201-F
A4R101	0757-0304	0	24	RESISTOR 51.1 1% .125W F TC#0+-100	24546	C4=1/8-T0=51R1-F
A4R102	0757-0306	2		RESISTOR 10 1% .125W F TC#0+-100	24546	C4=1/8-T0=10R0-F
A4R103	0757-0394	0		RESISTOR 51.1 1% .125W F TC#0+-100	24546	C4=1/8-T0=51R1-F
A4R104	0757-0306	2		RESISTOR 10 1% .125W F TC#0+-100	24546	C4=1/8-T0=10R0-F
A4R105	0757-0796	6	2	RESISTOR 82.5 1% .5W F TC#0+-100	28480	0757-0796
A4R106	0757-0796	6		RESISTOR 82.5 1% .5W F TC#0+-100	28480	0757-0796
A4R107	0757-0499	6	1	RESISTOR 27.4 1% .25W F TC#0+-100	19701	MF52C1/4-T0=27R4-F
A4R108	0698-4086	9		RESISTOR 22.6 1% .125W F TC#0+-100	03888	PF55=1/8-T0=22R6-F
A4R109	0698-4086	9		RESISTOR 22.6 1% .125W F TC#0+-100	03888	PF55=1/8-T0=22R6-F
A4R110	0757-0199	3	7	RESISTOR 21.5K 1% .125W F TC#0+-100	24546	C4=1/8-T0=2152-F
A4R111	2100-2030	6	1	RESISTOR-TRMR 20K 10% C TOP-ADJ 1-TRN	73138	82PR20K
A4R112	0757-1094	9	14	RESISTOR 1.47K 1% .125W F TC#0+-100	24546	C4=1/8-T0=1471-F
A4R113	0757-0200	7	3	RESISTOR 5.62K 1% .125W F TC#0+-100	24546	C4=1/8-T0=5621-F
A4R114	0698-4358	8	9	RESISTOR 4.02K 1% .125W F TC#0+-100	24546	C4=1/8-T0=4021-F
A4R115	2100-2061	3	5	RESISTOR-TRMR 200 10% C TOP-ADJ 1-TRN	73138	82PR200
A4R116	0757-0706	8		RESISTOR 51.1 1% .25W F TC#0+-100	24546	C5=1/4-T0=51R1-F
A4R117	0757-0995	7	1	RESISTOR 33.2 1% .5W F TC#0+-100	28480	0757-0995
A4R118	0757-0706	8		RESISTOR 51.1 1% .25W F TC#0+-100	24546	C5=1/4-T0=51R1-F
A4R119	0698-4425	0	7	RESISTOR 1.54K 1% .125W F TC#0+-100	24546	C4=1/8-T0=1541-F
A4R120	0757-0283	0		RESISTOR 2K 1% .125W F TC#0+-100	24546	C4=1/8-T0=2001-F
A4R121	0757-0280	3		RESISTOR 1K 1% .125W F TC#0+-100	24546	C4=1/8-T0=1001-F
A4R122	0757-0401	0		RESISTOR 100 1% .125W F TC#0+-100	24546	C4=1/8-T0=101-F
A4R123	0757-0387	1	1	RESISTOR 27.4 1% .125W F TC#0+-100	19701	MF4C1/8-T0=27R4-F
A4R124	0698-5418	3	4	RESISTOR 50 .1% .125W F TC#0+-50	28480	0698-5418
A4R125	0698-5418	3		RESISTOR 50 .1% .125W F TC#0+-50	28480	0698-5418
A4R126	0698-7205	0	6	RESISTOR 51.1 1% .05W F TC#0+-100	24546	C3=1/8-T00=51R1-G
A4R127	0757-0401	0		RESISTOR 100 1% .125W F TC#0+-100	24546	C4=1/8-T0=101-F
A4R128	0757-0180	2	1	RESISTOR 31.6 1% .125W F TC#0+-100	28480	0757-0180
A4R129	0698-5418	3		RESISTOR 50 .1% .125W F TC#0+-50	28480	0698-5418
A4R130	0698-5418	3		RESISTOR 50 .1% .125W F TC#0+-50	28480	0698-5418
A4R131	0698-7205	0		RESISTOR 51.1 1% .05W F TC#0+-100	24546	C3=1/8-T00=51R1-G
A4R132	0757-0401	0		RESISTOR 100 1% .125W F TC#0+-100	24546	C4=1/8-T0=101-F
A4R133	0757-0276	7	1	RESISTOR 81.9 1% .125W F TC#0+-100	24546	C4=1/8-T0=8192-F
A4R134	0698-4343	1	2	RESISTOR 100 .1% .125W F TC#0+-50	28480	0698-4343
A4R135	0698-4343	1		RESISTOR 100 .1% .125W F TC#0+-50	28480	0698-4343

Table 6-3. Replaceable Parts (cont'd)

Reference Designation	HP Part Number	C D	Qty	Description	Mfr Code	Mfr Part Number
A4R130	0698-7205	0		RESISTOR 51.1 1% .05W F TC=0+-100	24546	C3-1/8-T00-51R1-G
A4R13A	0757-0273	4	4	RESISTOR 3.01K 1% .125W F TC=0+-100	24546	C4-1/8-T0-3011-F
A4R139	0757-02A3	6		RESISTOR 2K 1% .125W F TC=0+-100	24546	C4-1/8-T0-2001-F
A4R140	0757-041A	9	3	RESISTOR 619 1% .125W F TC=0+-100	24546	C4-1/8-T0-619R-F
A4R141	0698-5174	8	2	RESISTOR 200 5% .125W CC TC=330/+800	01121	RR2015
A4R142	0698-5174	8		RESISTOR 200 5% .125W CC TC=330/+800	01121	RR2015
A4R144	0698-3113	1	1	RESISTOR 100 5% .125W CC TC=-270/+540	01121	RA1015
A4R151	0757-0199	3		RESISTOR 21.5K 1% .125W F TC=0+-100	24546	C4-1/8-T0-2152-F
A4R152	0757-0199	3		RESISTOR 21.5K 1% .125W F TC=0+-100	24546	C4-1/8-T0-2152-F
A4R153	0698-0084	9	1	RESISTOR 2.15K 1% .125W F TC=0+-100	24546	C4-1/8-T0-2151-F
A4R154	0757-0273	4		RESISTOR 3.01K 1% .125W F TC=0+-100	24546	C4-1/8-T0-3011-F
A4R155	0757-0401	0		RESISTOR 100 1% .125W F TC=0+-100	24546	C4-1/8-T0-101-F
A4R156	0757-1001	8	2	RESISTOR 56.2 1% .5W F TC=0+-100	28480	0757-1001
A4R157	0757-1001	6		RESISTOR 56.2 1% .5W F TC=0+-100	28480	0757-1001
A4R158	0757-02A0	3		RESISTOR 1K 1% .125W F TC=0+-100	24546	C4-1/8-T0-1001-F
A4R159	0757-0280	3		RESISTOR 1K 1% .125W F TC=0+-100	24546	C4-1/8-T0-1001-F
A4R160	0698-3442	9	3	RESISTOR 237 1% .125W F TC=0+-100	24546	C4-1/8-T0-237R-F
A4R161	2100-2061	3		RESISTOR-TRMR 200 10% C TOP=40J 1-TRN	73138	A2PR50
A4R162	0698-3132	4	4	RESISTOR 261 1% .125W F TC=0+-100	24546	C4-1/8-T0-2610-F
A4R201	0757-0346	2		RESISTOR 10 1% .125W F TC=0+-100	24546	C4-1/8-T0-10R0-F
A4R202	0757-0405	4	3	RESISTOR 162 1% .125W F TC=0+-100	24546	C4-1/8-T0-162R-F
A4R203	0698-4825	4	4	RESISTOR 64.9 1% .5W F TC=0+-100	28480	0698-4825
A4R204	0757-0794	4	4	RESISTOR 68.1 1% .5W F TC=0+-100	28480	0757-0794
A4R205	0757-0394	0		RESISTOR 51.1 1% .125W F TC=0+-100	24546	C4-1/8-T0-51R1-F
A4R206	0698-4825	0		RESISTOR 1.54K 1% .125W F TC=0+-100	24546	C4-1/8-T0-1541-F
A4R207	0698-5022	5	2	RESISTOR 40.2 1% .5W F TC=0+-100	28480	0698-5022
A4R208	0757-0280	3		RESISTOR 1K 1% .125W F TC=0+-100	24546	C4-1/8-T0-1001-F
A4R209	0757-0401	0		RESISTOR 100 1% .125W F TC=0+-100	24546	C4-1/8-T0-101-F
A4R211	0757-0346	2		RESISTOR 10 1% .125W F TC=0+-100	24546	C4-1/8-T0-10R0-F
A4R212	0757-0405	4		RESISTOR 162 1% .125W F TC=0+-100	24546	C4-1/8-T0-162R-F
A4R213	0698-4825	4		RESISTOR 64.9 1% .5W F TC=0+-100	28480	0698-4825
A4R214	0757-0794	4		RESISTOR 68.1 1% .5W F TC=0+-100	28480	0757-0794
A4R215	0757-0394	0		RESISTOR 51.1 1% .125W F TC=0+-100	24546	C4-1/8-T0-51R1-F
A4R216	0698-4825	0		RESISTOR 1.54K 1% .125W F TC=0+-100	24546	C4-1/8-T0-1541-F
A4R217	0698-4367	9	2	RESISTOR 20.5 1% .125W F TC=0+-100	03888	PVE55-1/8-T0-20R5-F
A4R218	0757-0702	4	2	RESISTOR 36.5 1% .25W F TC=0+-100	24546	C5-1/4-T0-36R5-F
A4R219	0757-02A0	3		RESISTOR 1K 1% .125W F TC=0+-100	24546	C4-1/8-T0-1001-F
A4R220	0757-0401	0		RESISTOR 100 1% .125W F TC=0+-100	24546	C4-1/8-T0-101-F
A4R221	0698-3162	0	6	RESISTOR 46.4K 1% .125W F TC=0+-100	24546	C4-1/8-T0-4642-F
A4R222	0757-0438	3		RESISTOR 5.11K 1% .125W F TC=0+-100	24546	C4-1/8-T0-5111-F
A4R223	0698-3162	0		RESISTOR 46.4K 1% .125W F TC=0+-100	24546	C4-1/8-T0-4642-F
A4R225	0757-0421	0	6	RESISTOR 825 1% .125W F TC=0+-100	24546	C4-1/8-T0-825R-F
A4R226	0757-0394	0		RESISTOR 51.1 1% .125W F TC=0+-100	24546	C4-1/8-T0-51R1-F
A4R227	0757-0421	4		RESISTOR 825 1% .125W F TC=0+-100	24546	C4-1/8-T0-825R-F
A4R228	0757-0421	4		RESISTOR 825 1% .125W F TC=0+-100	24546	C4-1/8-T0-825R-F
A4R229	0757-0394	0		RESISTOR 51.1 1% .125W F TC=0+-100	24546	C4-1/8-T0-51R1-F
A4R230	0757-0421	4		RESISTOR 825 1% .125W F TC=0+-100	24546	C4-1/8-T0-825R-F
A4R301	0757-0346	2		RESISTOR 10 1% .125W F TC=0+-100	24546	C4-1/8-T0-10R0-F
A4R302	0698-4413	6	4	RESISTOR 154 1% .125W F TC=0+-100	24546	C4-1/8-T0-154R-F
A4R303	0698-4825	4		RESISTOR 64.9 1% .5W F TC=0+-100	28480	0698-4825
A4R304	0757-0794	4		RESISTOR 68.1 1% .5W F TC=0+-100	28480	0757-0794
A4R305	0757-0394	4		R-FXD 51.1 1%	28480	0757-0794
A4R306	2100-2060	2	3	RESISTOR-TRMR 50 20% C TOP=ADJ 1-TRN	73138	A2PR50
A4R307	0698-5022	5		RESISTOR 40.2 1% .5W F TC=0+-100	28480	0698-5022
A4R308	0757-02A0	3		RESISTOR 1K 1% .125W F TC=0+-100	24546	C4-1/8-T0-1001-F
A4R309	0757-0401	0		RESISTOR 100 1% .125W F TC=0+-100	24546	C4-1/8-T0-101-F
A4R310	0757-0394	0		RESISTOR 51.1 1% .125W F TC=0+-100	24546	C4-1/8-T0-51R1-F
A4R311	0757-0346	2		RESISTOR 10 1% .125W F TC=0+-100	24546	C4-1/8-T0-10R0-F
A4R312	0698-4413	6		RESISTOR 154 1% .125W F TC=0+-100	24546	C4-1/8-T0-154R-F
A4R313	0698-4825	4		RESISTOR 64.9 1% .5W F TC=0+-100	28480	0698-4825
A4R314	0757-0794	4		RESISTOR 68.1 1% .5W F TC=0+-100	28480	0757-0794
A4R315	0757-0394	0		RESISTOR 51.1 1% .125W F TC=0+-100	24546	C4-1/8-T0-51R1-F
A4R317	0698-4367	9		RESISTOR 20.5 1% .125W F TC=0+-100	03888	PVE55-1/8-T0-20R5-F
A4R318	0757-0702	4		RESISTOR 36.5 1% .25W F TC=0+-100	24546	C5-1/4-T0-36R5-F
A4R319	0757-0280	3		RESISTOR 1K 1% .125W F TC=0+-100	24546	C4-1/8-T0-1001-F
A4R320	0757-0394	0		RESISTOR 51.1 1% .125W F TC=0+-100	24546	C4-1/8-T0-51R1-F
A4R321	0698-3162	0		RESISTOR 46.4K 1% .125W F TC=0+-100	24546	C4-1/8-T0-4642-F
A4R322	0757-0438	3		RESISTOR 5.11K 1% .125W F TC=0+-100	24546	C4-1/8-T0-5111-F
A4R323	0698-3162	0		RESISTOR 46.4K 1% .125W F TC=0+-100	24546	C4-1/8-T0-4642-F
A4R401	0698-A3A7	1	2	RESISTOR 247.5 1% .25W F TC=0+-50	19701	WF52C1/4-T2-247R5-B
A4R402	0698-7984	2	3	RESISTOR 61.1 1% .5W F TC=0+-50	28480	0698-7984
A4R403	0698-744A	3	2	RESISTOR 100 .1% .25W F TC=0+-25	19701	WF52C1/4-T9-100R-B
A4R404	0698-744A	3		RESISTOR 100 .1% .25W F TC=0+-25	19701	WF52C1/4-T9-100R-B
A4R405	0698-83A7	1		RESISTOR 247.5 1% .25W F TC=0+-50	19701	WF52C1/4-T2-247R5-B
A4R406	0698-7984	2		RESISTOR 61.1 1% .5W F TC=0+-50	28480	0698-7984

Table 6-3. Replaceable Parts (cont'd)

Reference Designation	HP Part Number	C D	Qty	Description	Mfr Code	Mfr Part Number
44R407	0698-7984	2		RESISTOR 61.1 1% .5W F TC=0+-50	28480	0698-7984
44R408	0698-8884	3	2	RESISTOR 150 1% .5W F TC=0+-25	28480	0698-8884
44R409	0698-8884	3		RESISTOR 150 1% .5W F TC=0+-25	28480	0698-8884
44R410	0698-3488	3	1	RESISTOR 442 1% .125W F TC=0+-100	24546	C4-1/8-T0-422R-F
44R501	0757-0438	3		RESISTOR 5.11K 1% .125W F TC=0+-100	24546	C4-1/8-T0-5111-F
44R502	0757-0721	7	1	RESISTOR 274 1% .25W F TC=0+-100	24546	C5-1/4-T0-274R-F
44R503	0757-0349	5		RESISTOR 22.6K 1% .125W F TC=0+-100	24546	C4-1/8-T0-2262-F
44R504	0757-0447	4	1	RESISTOR 16.2K 1% .125W F TC=0+-100	24546	C4-1/8-T0-1622-F
44R505	0757-0349	5		RESISTOR 22.6K 1% .125W F TC=0+-100	24546	C4-1/8-T0-2262-F
44R506	0698-3443	0	2	RESISTOR 287 1% .125W F TC=0+-100	24546	C4-1/8-T0-287R-F
44R507	0757-0394	0		RESISTOR 51.1 1% .125W F TC=0+-100	24546	C4-1/8-T0-511R-F
44R508	0757-0394	0		RESISTOR 51.1 1% .125W F TC=0+-100	24546	C4-1/8-T0-511R-F
44R510	0757-0349	5		RESISTOR 22.6K 1% .125W F TC=0+-100	24546	C4-1/8-T0-2262-F
44R511	0757-0438	3		RESISTOR 5.11K 1% .125W F TC=0+-100	24546	C4-1/8-T0-5111-F
44R512	0757-0416	7	3	RESISTOR 511 1% .125W F TC=0+-100	24546	C4-1/8-T0-511R-F
44R513	0698-3457	6	1	RESISTOR 316K 1% .125W F TC=0+-100	28480	0698-3457
44R514	0698-4539	7	1	RESISTOR 402K 1% .125W F TC=0+-100	28480	0698-4539
44R515	0698-3162	0		RESISTOR 46.4K 1% .125W F TC=0+-100	24546	C4-1/8-T0-4642-F
44R516	0757-0349	5		RESISTOR 22.6K 1% .125W F TC=0+-100	24546	C4-1/8-T0-2262-F
44R517	0698-3162	0		RESISTOR 46.4K 1% .125W F TC=0+-100	24546	C4-1/8-T0-4642-F
44R520	0757-0349	5		RESISTOR 22.6K 1% .125W F TC=0+-100	24546	C4-1/8-T0-2262-F
44R521	0757-0438	3		RESISTOR 5.11K 1% .125W F TC=0+-100	24546	C4-1/8-T0-5111-F
44R522	0757-0349	5		RESISTOR 22.6K 1% .125W F TC=0+-100	24546	C4-1/8-T0-2262-F
44R523	0757-0438	3		RESISTOR 5.11K 1% .125W F TC=0+-100	24546	C4-1/8-T0-5111-F
44R524	2100-2061	3		RESISTOR-TRMR 200 10% C TOP-ADJ 1-TRN	73138	82PR200
44R525	2100-2061	3		RESISTOR-TRMR 200 10% C TOP-ADJ 1-TRN	73138	82PR200
44R526	2100-2061	3		RESISTOR-TRMR 200 10% C TOP-ADJ 1-TRN	73138	82PR200
44U101	1826-0389	1	1	IC	28480	1826-0389
44U102	1826-0161	3	3	IC OP AMP GP QUAD 14-DIP-P	04713	uLM324P
44U201	1826-0043	4	13	IC OP AMP GP T0-99	0192B	CA307T
44U202	1826-0043	4		IC OP AMP GP T0-99	0192B	CA307T
44U501	1820-1961	5	2	IC GATE CMOS NAND TPL 3-INP	04713	MC14023BCP
44U502	1820-1961	5		IC GATE CMOS NAND TPL 3-INP	04713	MC14023BCP
44U503	1820-14A5	8	1	IC MV CMOS MONOSTBL DUAL	27014	MM74C221N
44VR101	1902-0935	5	6	DIODE-ZNR 9.1V 5% PD=5W IR=100UA	28480	1902-0935
44VR102	1902-0935	5		DIODE-ZNR 9.1V 5% PD=5W IR=100UA	28480	1902-0935
44VR103	1902-0777	3	5	DIODE-ZNR 14825 6.2V 5% CO-7 PD=.4W	04713	1N425
44VR104	1902-0534	0	2	DIODE-ZNR 3.74V 2% DO-15 PD=1K TC=-.053%	28480	1902-0534
44VR105	1902-0534	0		DIODE-ZNR 3.74V 2% DO-15 PD=1K TC=-.053%	28480	1902-0534
44VR107	1902-3182	0	2	DIODE-ZNR 12.1V 5% DO-7 PD=.4W TC=-.064%	28480	1902-3182
44VR201	1902-3094	3		DIODE-ZNR 5.11V 2% DO-7 PD=.4W TC=-.009%	28480	1902-3094
44VR202	1902-3188	6		DIODE-ZNR 12.7V 2% DO-7 PD=.4W TC=-.061%	28480	1902-3188
44VR203	1902-1285	0	2	DIODE-ZNR 12V 5% PD=5W IR=50UA	28480	1902-1285
44VR204	1902-3094	3		DIODE-ZNR 5.11V 2% DO-7 PD=.4W TC=-.009%	28480	1902-3094
44VR205	1902-3188	6		DIODE-ZNR 12.7V 2% DO-7 PD=.4W TC=-.061%	28480	1902-3188
44VR206	1902-1285	0		DIODE-ZNR 12V 5% PD=5W IR=50UA	28480	1902-1285
44VR207	1902-0935	5		DIODE-ZNR 9.1V 5% PD=5W IR=100UA	28480	1902-0935
44VR208	1902-0935	5		DIODE-ZNR 9.1V 5% PD=5W IR=100UA	28480	1902-0935
44VR301	1902-0935	5		DIODE-ZNR 9.1V 5% PD=5W IR=100UA	28480	1902-0935
44VR302	1902-0935	5		DIODE-ZNR 9.1V 5% PD=5W IR=100UA	28480	1902-0935
A5	08165-66505	8	1	BOARD ASSEMBLY, TIMING	28480	08165-66505
A5C1	0160-3712	7	1	CAPACITOR-FXD 3300PF +-10% 250VDC	28480	0160-3712
A5C2	0180-0375	4	1	CAPACITOR-FXD 68UF+-10% 20VDC TA	56289	150D886X902082
A5C3	0160-0174	9		CAPACITOR-FXD .47UF +-R0-20% 25VDC CER	28480	0160-0174
A5C4	0160-0574	2		C-FXD .022UF 100V	28480	0160-0573
A5C5	0160-0576	5		CAPACITOR-FXD .1UF +-20% 50VDC CER	28480	0160-0576
A5C6	0140-0196	3	1	CAPACITOR-FXD 150PF +-5% 300VDC MICA	72136	0M15F151J0300MV1CR
A5C7	0160-3879	7		CAPACITOR-FXD .01UF +-20% 100VDC CER	28480	0160-3879
A5C8	0140-0196	3		CAPACITOR-FXD 150PF +-5% 300VDC MICA	72136	0M15F151J0300MV1CR
A5C9	0160-3878	6		CAPACITOR-FXD 1000PF +-20% 100VDC CER	28480	0160-3878
A5C11	0160-3879	7		CAPACITOR-FXD .01UF +-20% 100VDC CER	28480	0160-3879
A5C12	0160-3694	4	2	CAPACITOR-FXD 330PF +-10% 100VDC CER	28480	0160-3694
A5C14	0160-0174	9		CAPACITOR-FXD .47UF +-R0-20% 25VDC CER	28480	0160-0174
A5C15	0180-2435	1	1	CAPACITOR-FXD 220UF+-50-10% 40VDC AL	28480	0180-2435
A5C16	0180-0149	0	1	CAPACITOR-FXD 65UF+-100-10% 60VDC AL	28480	0180-0149
A5C17	0160-3879	7		CAPACITOR-FXD .01UF +-20% 100VDC CER	28480	0160-3879
A5C18	0140-0196	3		CAPACITOR-FXD 150PF +-5% 300VDC MICA	72136	0M15F151J0300MV1CR
A5C19	0160-3879	7		CAPACITOR-FXD .01UF +-20% 100VDC CER	28480	0160-3879
A5C21	0160-0683	5	1	CAPACITOR-FXD .02UF +-2% 50VDC POLYSTY	28480	0160-0683
A5C22	0160-4270	4	1	CAPACITOR-FXD .2UF +-1% 50VDC MET-POLYCY	28480	0160-4270
A5C23	0160-0134	1		CAPACITOR-FXD 220PF +-5% 300VDC MICA	28480	0160-0134

Table 6-3. Replaceable Parts (cont'd)

Reference Designation	HP Part Number	C D	Qty	Description	Mfr Code	Mfr Part Number
ASC24	0160-4040	6	2	CAPACITOR-FXD 1000PF +-5% 100VDC CER	28480	0160-4040
ASC25	0160-4040	6		CAPACITOR-FXD 1000PF +-5% 100VDC CER	28480	0160-4040
ASC27	0160-3879	7		CAPACITOR-FXD .01UF +-20% 100VDC CER	28480	0160-3879
ASC2A	0160-3878	6		CAPACITOR-FXD 1000PF +-20% 100VDC CER	28480	0160-3878
ASC29	0160-3879	7		CAPACITOR-FXD .01UF +-20% 100VDC CER	28480	0160-3879
ASC31	0160-3878	6		CAPACITOR-FXD 1000PF +-20% 100VDC CER	28480	0160-3878
ASC32	0160-3873	1		CAPACITOR-FXD 4.7PF +- .5PF 200VDC CER	28480	0160-3873
ASC33	0160-0229	7	2	CAPACITOR-FXD 33UF+-10% 10VDC TA	56289	150D336X901082
ASC34	0160-3879	7		CAPACITOR-FXD .01UF +-20% 100VDC CER	28480	0160-3879
ASC35	0160-3879	7		CAPACITOR-FXD .01UF +-20% 100VDC CER	28480	0160-3879
ASC36	0160-3878	6		CAPACITOR-FXD 1000PF +-20% 100VDC CER	28480	0160-3878
ASC37	0160-0174	9		CAPACITOR-FXD .47UF +80-20% 25VDC CER	28480	0160-0174
ASC38	0160-0570	9		CAPACITOR-FXD 220PF +-20% 100VDC CER	20932	5024EM100RD221M
ASC39	0160-0576	5		CAPACITOR-FXD .1UF +-20% 50VDC CER	28480	0160-0576
ASC40	0160-0174	9		CAPACITOR-FXD .47UF +80-20% 25VDC CER	28480	0160-0174
ASC41	0160-0576	5		CAPACITOR-FXD .1UF +-20% 50VDC CER	28480	0160-0576
ASC101	0160-3877	5	2	CAPACITOR-FXD 100PF +-20% 200VDC CER	28480	0160-3877
ASC102	0160-0576	5		CAPACITOR-FXD .1UF +-20% 50VDC CER	28480	0160-0576
ASC103	0160-3877	5		CAPACITOR-FXD 100PF +-20% 200VDC CER	28480	0160-3877
ASC104	0160-3879	7		CAPACITOR-FXD .01UF +-20% 100VDC CER	28480	0160-3879
ASC105	0160-3879	7		CAPACITOR-FXD .01UF +-20% 100VDC CER	28480	0160-3879
ASC106	0160-0197	8		CAPACITOR-FXD 2.2UF+-10% 25VDC TA	56289	150D225X9020A2
ASC107	0160-0576	5		CAPACITOR-FXD .1UF +-20% 50VDC CER	28480	0160-0576
ASC201	0160-3879	7		CAPACITOR-FXD .01UF +-20% 100VDC CER	28480	0160-3879
ASC202	0160-0576	5		CAPACITOR-FXD .1UF +-20% 50VDC CER	28480	0160-0576
ASC203	0160-3879	7		CAPACITOR-FXD .01UF +-20% 100VDC CER	28480	0160-3879
ASC204	0160-0174	9		CAPACITOR-FXD .47UF +80-20% 25VDC CER	28480	0160-0174
ASC205	0160-3879	7		CAPACITOR-FXD .01UF +-20% 100VDC CER	28480	0160-3879
ASC206	0160-1974	1	1	CAPACITOR-FXD 100UF+-10% 35VDC TA	56289	150D106X9035R2
ASC207	0160-3879	7		CAPACITOR-FXD .01UF +-20% 100VDC CER	28480	0160-3879
ASC208	0160-3878	6		CAPACITOR-FXD 1000PF +-20% 100VDC CER	28480	0160-3878
ASC210	0160-0576	5		CAPACITOR-FXD .1UF +-20% 50VDC CER	28480	0160-0576
ASC211	0160-0128	3		CAPACITOR-FXD 2.2UF +-20% 50VDC CER	28480	0160-0128
ASC212	0160-0576	5		CAPACITOR-FXD .1UF +-20% 50VDC CER	28480	0160-0576
ASC301	0160-3878	6		CAPACITOR-FXD 1000PF +-20% 100VDC CER	28480	0160-3878
ASC302	0160-0576	5		CAPACITOR-FXD .1UF +-20% 50VDC CER	28480	0160-0576
ASC303	0160-0576	5		CAPACITOR-FXD .1UF +-20% 50VDC CER	28480	0160-0576
ASC304	0160-3879	7		CAPACITOR-FXD .01UF +-20% 100VDC CER	28480	0160-3879
ASC305	0160-3694	4		CAPACITOR-FXD 330PF +-10% 100VDC CER	28480	0160-3694
ASC306	0160-0576	5		CAPACITOR-FXD .1UF +-20% 50VDC CER	28480	0160-0576
ASC307	0160-3879	7		CAPACITOR-FXD .01UF +-20% 100VDC CER	28480	0160-3879
ASC308	0160-3879	7		CAPACITOR-FXD .01UF +-20% 100VDC CER	28480	0160-3879
ASC309	0121-0467	1	1	CAPACITOR-V TRMR-CER 2.5-9PF 100V PC-MTG	28480	0121-0467
ASC310	0160-3878	6		CAPACITOR-FXD 1000PF +-20% 100VDC CER	28480	0160-3878
ASC311	0160-3875	3	2	CAPACITOR-FXD 22PF +-5% 200VDC CER 0+-30	28480	0160-3875
ASC312	0160-3873	1		CAPACITOR-FXD 4.7PF +- .5PF 200VDC CER	28480	0160-3873
ASC401	0160-3879	7		CAPACITOR-FXD .01UF +-20% 100VDC CER	28480	0160-3879
ASC402	0160-3879	7		CAPACITOR-FXD .01UF +-20% 100VDC CER	28480	0160-3879
ASC403	0160-3879	7		CAPACITOR-FXD .01UF +-20% 100VDC CER	28480	0160-3879
ASC404	0160-3879	7		CAPACITOR-FXD .01UF +-20% 100VDC CER	28480	0160-3879
ASC406	0160-0128	3		C-FXD 2.2UF 25V		
ASC405	0160-0174	9		CAPACITOR-FXD .47UF +80-20% 25VDC CER	28480	0160-0174
ASC501	0160-3878	6		CAPACITOR-FXD 1000PF +-20% 100VDC CER	28480	0160-3878
ASC502	0160-0576	5		CAPACITOR-FXD .1UF +-20% 50VDC CER	28480	0160-0576
ASC503	0160-2207	5	1	CAPACITOR-FXD 100UF+-10% 10VDC TA	56289	150D107X9010R2
ASC504	0160-3879	7		CAPACITOR-FXD .01UF +-20% 100VDC CER	28480	0160-3879
ASC505	0160-3879	7		CAPACITOR-FXD .01UF +-20% 100VDC CER	28480	0160-3879
ASC506	0160-2208	6	1	CAPACITOR-FXD 220UF+-10% 10VDC TA	56289	150D227X901082
ASCR1	1901-0363	3	1	DIODE-FW BRDG 100V 1A	28480	1901-0363
ASCR2	1901-0050	1		DIODE-SWITCHING 80V 200MA 2%S DO-35	28480	1901-0050
ASCR101	1901-1068	5	0	DIODE-SCHOTTKY	28480	1901-1068
ASCR102	1901-1068	5		DIODE-SCHOTTKY	28480	1901-1068
ASCR103	1901-0533	7	2	DIODE-SCHOTTKY	28480	1901-0533
ASCR104	1901-0533	7		DIODE-SCHOTTKY	28480	1901-0533
ASCR201	1901-1068	5		DIODE-SCHOTTKY	28480	1901-1068
ASCR202	1901-1068	5		DIODE-SCHOTTKY	28480	1901-1068
ASCR203	1901-1068	5		DIODE-SCHOTTKY	28480	1901-1068
ASCR204	1901-1068	5		DIODE-SCHOTTKY	28480	1901-1068
ASCR205	1901-1068	5		DIODE-SCHOTTKY	28480	1901-1068
ASCR301	1901-1068	5		DIODE-SCHOTTKY	28480	1901-1068
ASCR401	1901-1068	5		DIODE-SCHOTTKY	28480	1901-1068
ASCR501	1901-0040	1		DIODE-SWITCHING 30V 50MA 2%S DO-35	28480	1901-0040
ASCR502	1901-0040	1		DIODE-SWITCHING 30V 50MA 2%S DO-35	28480	1901-0040
ASCR503	1901-0040	1		DIODE-SWITCHING 30V 50MA 2%S DO-35	28480	1901-0040
ASCR504	1901-0040	1		DIODE-SWITCHING 30V 50MA 2%S DO-35	28480	1901-0040
ASCR505	1901-0040	1		DIODE-SWITCHING 30V 50MA 2%S DO-35	28480	1901-0040
ASCR506	1901-0040	1		DIODE-SWITCHING 30V 50MA 2%S DO-35	28480	1901-0040
ASCR507	1901-0040	1		DIODE-SWITCHING 30V 50MA 2%S DO-35	28480	1901-0040

Table 6-3. Replaceable Parts (cont'd)

Reference Designation	HP Part Number	C D	Qty	Description	Mfr Code	Mfr Part Number
A5CR90A	1901-0040	1	2	DIODE-SWITCHING 30V 50MA 2NS DD=35	28480	1901-0040
A5CR909	1901-0047	8		DIODE-SWITCHING 20V 75MA 1NS	28480	1901-0047
A5CR910	1901-0047	5		DIODE-SWITCHING 20V 75MA 1NS	28480	1901-0047
A5CR912	1901-0040	1		DIODE-SWITCHING 30V 50MA 2NS DD=35	28480	1901-0040
A5CR913	1901-0040	1		DIODE-SWITCHING 30V 50MA 2NS DD=35	28480	1901-0040
A5CR914	1901-0040	1	DIODE-SWITCHING 30V 50MA 2NS DD=35	28480	1901-0040	
A5CR601	1901-0040	1	DIODE-SWITCHING 30V 50MA 2NS DD=35	28480	1901-0040	
A5CR701	1901-0731	7	DIODE-PWR RECT 400V 1A	28480	1901-0731	
A5J1	1251-2026	8	2	CONNECTOR-PC EDGE 18-CONT/ROW 2-ROWS	28480	1251-2026
A5J2	1251-2026	8		CONNECTOR-PC EDGE 18-CONT/ROW 2-ROWS	28480	1251-2026
A5J3	1251-2026	8		CONNECTOR-PC EDGE 18-CONT/ROW 2-ROWS	28480	1251-2026
A5J4	1251-2582	1		CONNECTOR-PC EDGE 24-CONT/ROW 2-ROWS	28480	1251-2582
A5J5	1251-2026	8		CONNECTOR-PC EDGE 18-CONT/ROW 2-ROWS	28480	1251-2026
A5J6	1251-2582	1	CONNECTOR-PC EDGE 24-CONT/ROW 2-ROWS	28480	1251-2582	
A5J7	1251-4504	1	2	CONNECTOR 10-PIN M POST TYPE	28480	1251-4504
A5J8	1251-4504	1		CONNECTOR 10-PIN M POST TYPE	28480	1251-4504
A5J11	1251-3119	2		CONNECTOR 20-PIN M RECTANGULAR	28480	1251-3119
A5K1	0490-1079	4		RELAY-REED 1A 500MA 100VDC 5VDC-COIL	28480	0490-1079
A5K2	0490-1079	4		RELAY-REED 1A 500MA 100VDC 5VDC-COIL	28480	0490-1079
A5K3	0490-1079	4	RELAY-REED 1A 500MA 100VDC 5VDC-COIL	28480	0490-1079	
A5K4	0490-1079	4	RELAY-REED 1A 500MA 100VDC 5VDC-COIL	28480	0490-1079	
A5K5	0490-1079	4	RELAY-REED 1A 500MA 100VDC 5VDC-COIL	28480	0490-1079	
A5K301	0490-0617	4	RELAY-REED 1C 250MA 2AVDC 5VDC-COIL	28480	0490-0617	
A5K302	0490-1079	4	RELAY-REED 1A 500MA 100VDC 5VDC-COIL	28480	0490-1079	
A5K401	0490-0617	4	RELAY-REED 1C 250MA 2AVDC 5VDC-COIL	28480	0490-0617	
A5L1	9100-1647	6	2	COIL-MLD 470UH 5% Q=65 .190X.44LG-NOM	28480	9100-1647
A5L2	5081-1973	5		INDUCTANCE, 3-BEAD	28480	5081-1973
A5L3	5081-1973	5		INDUCTANCE, 3-BEAD	28480	5081-1973
A5L5	9170-0029	3		CORE-SHIELDING BEAD	28480	9170-0029
A5L6	9170-0029	3		CORE-SHIELDING BEAD	28480	9170-0029
A5L7	9170-0029	3	CORE-SHIELDING BEAD	28480	9170-0029	
A5L8	9170-0029	3	CORE-SHIELDING BEAD	28480	9170-0029	
A5L9	9170-0029	3	CORE-SHIELDING BEAD	28480	9170-0029	
A5L10	9100-2251	0	1	COIL-MLD 220NH 10% Q=32 .095DX.25LG-NOM	28480	9100-2251
A5L11	9100-2252	1		COIL-MLD 270NH 10% Q=30 .095DX.25LG-NOM	28480	9100-2252
A5L12	9170-0029	3		CORE-SHIELDING BEAD	28480	9170-0029
A5L201	9170-0029	3		CORE-SHIELDING BEAD	28480	9170-0029
A5L301	9170-0029	3		CORE-SHIELDING BEAD	28480	9170-0029
A5L302	9100-2247	4	1	COIL-MLD 160NH 10% Q=34 .095DX.25LG-NOM	28480	9100-2247
A5L303	9170-0029	3		CORE-SHIELDING BEAD	28480	9170-0029
A5L401	9170-0029	3		CORE-SHIELDING BEAD	28480	9170-0029
A5L402	9100-1647	6		COIL-MLD 470UH 5% Q=65 .190X.44LG-NOM	28480	9100-1647
A5L403	5081-1973	5		INDUCTANCE, 3-BEAD	28480	5081-1973
A5L405	9100-0346	0	1	COIL-MLD 50NH 20% Q=40 .095DX.25LG-NOM	28480	9100-0346
A5L406	9170-0029	3		CORE-SHIELDING BEAD	28480	9170-0029
A5L407	9170-0029	3		CORE-SHIELDING BEAD	28480	9170-0029
A5L501	9140-0210	1		COIL-SHIELDING BEAD	28480	9140-0210
A5MP1	1205-0011	0		2	HEAT SINK TO-5/TD=39-CS	28480
A5MP2	01801-22301	7	HEAT SINK		28480	01801-22301
A5MP3	1205-0204	3	HEAT SINK TO-18-CS		28480	1205-0204
A5MP4	1205-0037	0	HEAT SINK TO-18-CS		28480	1205-0037
A5MP5	08165-03202	0	COUPLER, THERMAL		28480	08165-03202
A5MP6	1205-0037	0	HEAT SINK TO-18-CS	28480	1205-0037	
A5MP7	1205-0037	0	HEAT SINK TO-18-CS	28480	1205-0037	
A5MP201	1205-0037	0	HEAT SINK TO-18-CS	28480	1205-0037	
A5MP202	1205-0037	0	HEAT SINK TO-18-CS	28480	1205-0037	
A5MP301	1205-0011	0	HEAT SINK TO-5/TD=39-CS	28480	1205-0011	
A5MP302	1205-0037	0	HEAT SINK TO-18-CS	28480	1205-0037	
A5MP401	1205-0037	0	HEAT SINK TO-18-CS	28480	1205-0037	
A5Q1	1854-0477	7	5	TRANSISTOR NPN 2N2222A SI TO-18 PD=500MW	04713	2N2222A
A5Q2	1854-0472	2		TRANSISTOR NPN SI DARL PD=500MW	04713	MP8=A14
A5Q3	1853-0086	2		TRANSISTOR PNP SI PD=310MW FT=40MHZ	27014	2N5087
A5Q4	1853-0281	9		TRANSISTOR PNP 2N2907A SI TO-18 PD=400MW	04713	2N2907A
A5Q5	1853-0086	2		TRANSISTOR PNP SI PD=310MW FT=40MHZ	27014	2N5087
A5Q6	1853-0086	2	2	TRANSISTOR PNP SI PD=310MW FT=40MHZ	27014	2N5087
A5Q7	1853-0075	9		TRANSISTOR-DUAL PNP PD=400MW	28480	1853-0075
A5Q8	1853-0314	9		TRANSISTOR PNP 2N2905A SI TO-39 PD=600MW	04713	2N2905A
A5Q9	1854-0472	2		TRANSISTOR NPN SI DARL PD=500MW	04713	MP8=A14
A5Q10	1855-0215	3		TRANSISTOR MOSFET N-CHAN E-MODE TO-72 SI	28480	1855-0215
A5Q12	5081-1977	9	1	FET, SELECTED	28480	5081-1977
A5Q13	1854-0485	7		TRANSISTOR NPN SI TO-104 PD=175MW	28480	1854-0485
A5Q14	1854-0354	9		TRANSISTOR NPN SI TO-52 PD=360MW	28480	1854-0354
A5Q16	1854-0485	7		TRANSISTOR NPN SI TO-104 PD=175MW	28480	1854-0485
A5Q17	1854-0485	7		TRANSISTOR NPN SI TO-104 PD=175MW	28480	1854-0485

Table 6-3. Replaceable Parts (cont'd)

Reference Designation	HP Part Number	C D	Qty	Description	Mfr Code	Mfr Part Number
A501A	1A54-0305	0	2	TRANSISTOR NPN SI TO-18 PD=400MW	2A480	1A54-0305
A5019	1A54-0305	0		TRANSISTOR NPN SI TO-18 PD=400MW	2A480	1A54-0305
A5020	1A55-0215	3		TRANSISTOR MOSFET N-CHAN E-MODE TO-72 SI	2A480	1A55-0215
A5021	1A54-0472	2		TRANSISTOR NPN SI DARL PD=500MW	04713	MP8-A14
A5022	1A54-0485	7		TRANSISTOR NPN SI TO-184 PD=175MW	2A480	1A54-0485
A5023	1A54-0354	9		TRANSISTOR NPN SI TO-52 PD=360MW	2A480	1A54-0354
A5024	1A54-0215	1		TRANSISTOR NPN SI PD=350MW FT=300MHZ	04713	2N3904
A5025	1A53-0357	0	A	TRANSISTOR PNP SI TO-18 PD=360MW	2A480	1A53-0357
A50101	1A53-0357	0		TRANSISTOR PNP SI TO-18 PD=360MW	2A480	1A53-0357
A50102	1A53-0357	0		TRANSISTOR PNP SI TO-18 PD=360MW	2A480	1A53-0357
A50103	1A53-0357	0		TRANSISTOR PNP SI TO-18 PD=360MW	2A480	1A53-0357
A50104	1A53-0314	9		TRANSISTOR PNP 2N2905A SI TO-39 PD=600MW	04713	2N2905A
A50105	1A54-0472	2		TRANSISTOR NPN SI DARL PD=500MW	04713	MP8-A14
A50106	1A54-0354	9		TRANSISTOR NPN SI TO-52 PD=360MW	2A480	1A54-0354
A50107	1A54-0637	1		TRANSISTOR NPN 2N2219A SI TO-5 PD=800MW	01295	2N2219A
A50108	1A55-0215	3		TRANSISTOR MOSFET N-CHAN E-MODE TO-72 SI	2A480	1A55-0215
A50109	1A53-0036	2		TRANSISTOR PNP SI PD=310MW FT=250MHZ	2A480	1A53-0036
A50201	1A54-0354	9		TRANSISTOR NPN SI TO-52 PD=360MW	2A480	1A54-0354
A50202	1A54-0215	1		TRANSISTOR NPN SI PD=350MW FT=300MHZ	04713	2N3904
A50203	1A53-0357	0		TRANSISTOR PNP SI TO-18 PD=360MW	2A480	1A53-0357
A50204	1A53-0357	0		TRANSISTOR PNP SI TO-18 PD=360MW	2A480	1A53-0357
A50205	1A54-0215	1		TRANSISTOR NPN SI PD=350MW FT=300MHZ	04713	2N3904
A50206	1A53-0357	0		TRANSISTOR PNP SI TO-18 PD=360MW	2A480	1A53-0357
A50207	1A53-0281	9		TRANSISTOR PNP 2N2907A SI TO-18 PD=400MW	04713	2N2907A
A50208	1A53-0357	0		TRANSISTOR PNP SI TO-18 PD=360MW	2A480	1A53-0357
A50209	1A53-0036	2		TRANSISTOR PNP SI PD=310MW FT=250MHZ	2A480	1A53-0036
A50210	1A53-0036	2		TRANSISTOR PNP SI PD=310MW FT=250MHZ	2A480	1A53-0036
A50211	1A54-0215	1		TRANSISTOR NPN SI PD=350MW FT=300MHZ	04713	2N3904
A50212	1A53-0314	9		TRANSISTOR PNP 2N2905A SI TO-39 PD=600MW	04713	2N2905A
A50301	1A54-0354	9		TRANSISTOR NPN SI TO-52 PD=360MW	2A480	1A54-0354
A50302	1A53-0281	9		TRANSISTOR PNP 2N2907A SI TO-18 PD=400MW	04713	2N2907A
A50303	1A53-0075	2		TRANSISTOR DUAL PNP PD=400MW	2A480	1A53-0075
A50304	1A53-0036	9		TRANSISTOR PNP SI PD=310MW FT=250MHZ	2A480	1A53-0036
A50401	1A54-0354	9		TRANSISTOR NPN SI TO-52 PD=360MW	2A480	1A54-0354
A50402	1A54-0477	7		TRANSISTOR NPN 2N2222A SI TO-18 PD=500MW	04713	2N2222A
A50403	1A53-0036	2		TRANSISTOR PNP SI PD=310MW FT=250MHZ	2A480	1A53-0036
A50404	1A54-0354	9		TRANSISTOR NPN SI TO-52 PD=360MW	2A480	1A54-0354
A50501	1A54-0215	1		TRANSISTOR NPN SI PD=350MW FT=300MHZ	04713	2N3904
A50502	1A54-0215	1		TRANSISTOR NPN SI PD=350MW FT=300MHZ	04713	2N3904
A50503	1A54-0215	1		TRANSISTOR NPN SI PD=350MW FT=300MHZ	04713	2N3904
A50504	1A54-0215	1		TRANSISTOR NPN SI PD=350MW FT=300MHZ	04713	2N3904
A50505	1A54-0215	1		TRANSISTOR NPN SI PD=350MW FT=300MHZ	04713	2N3904
A50506	1A54-0215	1		TRANSISTOR NPN SI PD=350MW FT=300MHZ	04713	2N3904
A50507	1A54-0215	1		TRANSISTOR NPN SI PD=350MW FT=300MHZ	04713	2N3904
A50508	1A54-0215	1		TRANSISTOR NPN SI PD=350MW FT=300MHZ	04713	2N3904
A50509	1A53-0036	2		TRANSISTOR PNP SI PD=310MW FT=250MHZ	2A480	1A53-0036
A50510	1A53-0036	2		TRANSISTOR PNP SI PD=310MW FT=250MHZ	2A480	1A53-0036
A50511	1A54-0215	1		TRANSISTOR NPN SI PD=350MW FT=300MHZ	04713	2N3904
A50512	1A54-0215	1		TRANSISTOR NPN SI PD=350MW FT=300MHZ	04713	2N3904
A50513	1A54-0583	6	A	TRANSISTOR NPN SI TO-92 PD=310MW	04713	MP8-A18
A50514	1A54-0215	1		TRANSISTOR NPN SI PD=350MW FT=300MHZ	04713	2N3904
A50515	1A54-0215	1		TRANSISTOR NPN SI PD=350MW FT=300MHZ	04713	2N3904
A50516	1A54-0215	1		TRANSISTOR NPN SI PD=350MW FT=300MHZ	04713	2N3904
A50517	1A53-0036	2		TRANSISTOR PNP SI PD=310MW FT=250MHZ	2A480	1A53-0036
A50518	1A54-0215	1		TRANSISTOR NPN SI PD=350MW FT=300MHZ	04713	2N3904
A50601	1A54-0215	1		TRANSISTOR NPN SI PD=350MW FT=300MHZ	04713	2N3904
A5R1	0757-0280	3		RESISTOR 1k 1% .125W F TC=0+-100	24546	C4=1/8-T0=1001-F
A5R2	0757-0449	6	7	RESISTOR 20k 1% .125W F TC=0+-100	24546	C4=1/8-T0=2002-F
A5R3	0698-4428	3	5	RESISTOR 1.69k 1% .125W F TC=0+-100	24546	C4=1/8-T0=1691-F
A5R4	0757-0401	0		RESISTOR 100 1% .125W F TC=0+-100	24546	C4=1/8-T0=101-F
A5R5	0757-0465	6		RESISTOR 100k 1% .125W F TC=0+-100	24546	C4=1/8-T0=1003-F
A5R6	0698-6615	4	1	RESISTOR 3.75k .1% .125W F TC=0+-25	28480	0698-6615
A5R7	0757-0453	2	1	RESISTOR 30.1k 1% .125W F TC=0+-100	24546	C4=1/8-T0=3012-F
A5R8	0698-6624	5	1	RESISTOR 2k .1% .125W F TC=0+-25	28480	0698-6624
A5R9	0757-0407	6	7	RESISTOR 200 1% .125W F TC=0+-100	24546	C4=1/8-T0=201-F
A5R10	2100-3210	6	1	RESISTOR-TRMR 10k 10% C TOP=ADJ 1-TRN	28480	2100-3210
A5R11	069A-3558	8		RESISTOR 4.02k 1% .125W F TC=0+-100	24546	C4=1/8-T0=4021-F
A5R12	0757-0200	7		RESISTOR 5.62k 1% .125W F TC=0+-100	24546	C4=1/8-T0=5621-F
A5R13	0698-5453	6	2	RESISTOR 900 .1% .125W F TC=0+-50	03888	PM55 T=2-900R-R
A5R14	0698-5453	6		RESISTOR 900 .1% .125W F TC=0+-50	03888	PM55 T=2-900R-R
A5R15	0698-4086	9		RESISTOR 22.0 1% .125W F TC=0+-100	03888	PM55-1/8-T0=22R6-F
A5R16	0698-6616	5	1	RESISTOR 750 .1% .125W F TC=0+-25	28480	0698-6616
A5R17	069A-4424	9	4	RESISTOR 1.4k 1% .125W F TC=0+-100	24546	C4=1/8-T0=1401-F
A5R18	0757-0280	3	1	RESISTOR 1k 1% .125W F TC=0+-100	24546	C4=1/8-T0=1001-F
A5R19	0698-4435	2	5	RESISTOR 2.49k 1% .125W F TC=0+-100	24546	C4=1/8-T0=2491-F
A5R20	0698-3499	6	2	RESISTOR 40.2k 1% .125W F TC=0+-100	24546	C4=1/8-T0=4022-F

Table 6—3. Replaceable Parts (cont'd)

Reference Designation	HP Part Number	C D	Qty	Description	Mfr Code	Mfr Part Number
A5R21	069A-3178	8		RESISTOR 487 1X .125W F TC=0+100	24546	C4-1/8-T0=487R-F
A5R22	0698-9824	1	1	RESISTOR 562K 1X .125W F TC=0+100	28480	0698-8824
A5R23	0698-7209	4	1	RESISTOR 75 1X .05W F TC=0+100	24546	C3-1/8-T00=75R0-G
A5R24	069A-3152	8	3	RESISTOR 3.48K 1X .125W F TC=0+100	24546	C4-1/8-T0=3481-F
A5R25	069A-71A8	8	4	RESISTOR 10 1X .05W F TC=0+100	24546	C3-1/8-T00=10R-G
A5R26	0698-4444	3		RESISTOR 4.87K 1X .125W F TC=0+100	24546	C4-1/8-T0=4871-F
A5R27	0757-0449	6		RESISTOR 20K 1X .125W F TC=0+100	24546	C4-1/8-T0=2002-F
A5R28	069A-3223	4	2	RESISTOR 1.24K 1X .125W F TC=0+100	24546	C4-1/8-T0=1241-F
A5R29	0757-0401	0		RESISTOR 100 1X .125W F TC=0+100	24546	C4-1/8-T0=101-F
A5R31	0757-0407	6		RESISTOR 200 1X .125W F TC=0+100	24546	C4-1/8-T0=201-F
A5R32	069A-3223	4		RESISTOR 1.24K 1X .125W F TC=0+100	24546	C4-1/8-T0=1241-F
A5R34	069A-5094	1	3	RESISTOR 5.1M 5X .25W FC TC=900/+1100	01121	CA5155
A5R36	0698-3557	7	1	RESISTOR 806 1X .125W F TC=0+100	24546	C4-1/8-T0=806R-F
A5R38	0698-4456	7	1	RESISTOR 549 1X .125W F TC=0+100	24546	C4-1/8-T0=549R-F
A5R40	0698-3458	9	1	R-FXD 348 K 1% .125W	24546	C4-1/8-T0=3013-F
A5R41	0757-0346	2		RESISTOR 10 1X .125W F TC=0+100	24546	C4-1/8-T0=10R0-F
A5R42	0757-0283	6		RESISTOR 2K 1X .125W F TC=0+100	24546	C4-1/8-T0=2001-F
A5R43	0698-4435	2		RESISTOR 2.49K 1X .125W F TC=0+100	24546	C4-1/8-T0=2491-F
A5R45	0757-0394	0		RESISTOR 51.1 1X .125W F TC=0+100	24546	C4-1/8-T0=51R1-F
A5R50	0698-3438	2	4	R-FXD 147 1% .125W	24546	C4-1/8-T0=133R-F
A5R51	2100-2060	2		RESISTOR-TRMR 50 20X C TOP-ADJ 1-TRN	73138	A2PR50
A5R52	0757-0346	2		RESISTOR 10 1X .125W F TC=0+100	24546	C4-1/8-T0=10R0-F
A5R53	0757-0407	6		RESISTOR 200 1X .125W F TC=0+100	24546	C4-1/8-T0=201-F
A5R54	0698-4455	6	2	RESISTOR 536 1X .125W F TC=0+100	24546	C4-1/8-T0=536R-F
A5R55	0698-7221	0	1	RESISTOR 237 1X .05W F TC=0+100	24546	C3-1/8-T0=237R-G
A5R56	0757-0394	0		RESISTOR 51.1 1X .125W F TC=0+100	24546	C4-1/8-T0=51R1-F
A5R57	0757-0274	5	10	RESISTOR 1.21K 1X .125W F TC=0+100	24546	C4-1/8-T0=1213-F
A5R58	0757-0388	2	6	RESISTOR 30.1 1X .125W F TC=0+100	24546	C4-1/8-T0=30R1-F
A5R60	0757-0346	2		RESISTOR 10 1X .125W F TC=0+100	24546	C4-1/8-T0=10R0-F
A5R61	069A-4422	7	3	RESISTOR 1.27K 1X .125W F TC=0+100	24546	C4-1/8-T0=1271-F
A5R62	0757-0407	6		RESISTOR 200 1X .125W F TC=0+100	24546	C4-1/8-T0=201-F
A5R63	0698-4455	6		RESISTOR 536 1X .125W F TC=0+100	24546	C4-1/8-T0=536R-F
A5R64	0698-3111	9	A	RESISTOR 30 5X .125W CC TC=270/+540	01121	BB3005
A5R65	0698-7205	0		RESISTOR 51.1 1X .05W F TC=0+100	24546	C3-1/8-T00=51R1-G
A5R66	0698-4424	9		RESISTOR 1.4K 1X .125W F TC=0+100	24546	C4-1/8-T0=1401-F
A5R67	0757-0438	3		RESISTOR 5.11K 1X .125W F TC=0+100	24546	C4-1/8-T0=5111-F
A5R68	0757-0290	5	4	RESISTOR 6.19K 1X .125W F TC=0+100	19701	MF4C1/8-T0=6191-F
A5R69	0757-0407	6		RESISTOR 200 1X .125W F TC=0+100	24546	C4-1/8-T0=201-F
A5R70	0757-0405	4		RESISTOR 162 1X .125W F TC=0+100	24546	C4-1/8-T0=162R-F
A5R71	2100-3288	8	1	RESISTOR-TRMR 50 20X C TOP-ADJ 17-TRN	28480	2100-3288
A5R73	0698-4424	9		RESISTOR 1.4K 1X .125W F TC=0+100	24546	C4-1/8-T0=1401-F
A5R74	0757-0388	2		RESISTOR 30.1 1X .125W F TC=0+100	24546	C4-1/8-T0=30R1-F
A5R76	0698-3439	4		RESISTOR 178 1X .125W F TC=0+100	24546	C4-1/8-T0=178R-F
A5R77	0757-0384	8		RESISTOR 20 1X .125W F TC=0+100	19701	MF4C1/8-T0=20R0-F
A5R78	0698-3442	9		RESISTOR 237 1X .125W F TC=0+100	24546	C4-1/8-T0=237R-F
A5R80	0757-1094	9		RESISTOR 1.47K 1X .125W F TC=0+100	24546	C4-1/8-T0=1471-F
A5R81	0757-0433	8	5	RESISTOR 3.32K 1X .125W F TC=0+100	24546	C4-1/8-T0=3321-F
A5R82	0698-4435	2		RESISTOR 2.49K 1X .125W F TC=0+100	24546	C4-1/8-T0=2491-F
A5R83	0757-0816	1	1	RESISTOR 681 1X .5W F TC=0+100	28480	0757-0816
A5R84	0698-4379	3	1	RESISTOR 44.2 1X .125W F TC=0+100	24546	C4-1/8-T0=44R2-F
A5R85	0757-0398	4	1	RESISTOR 75 1X .125W F TC=0+100	24546	C4-1/8-T0=75R0-F
A5R86	0757-0407	6		RESISTOR 200 1X .125W F TC=0+100	24546	C4-1/8-T0=201-F
A5R87	0757-0428	1	2	RESISTOR 1.62K 1X .125W F TC=0+100	24546	C4-1/8-T0=1621-F
A5R88	0757-0388	2		RESISTOR 30.1 1X .125W F TC=0+100	24546	C4-1/8-T0=30R1-F
A5R101	0757-0401	0		RESISTOR 100 1X .125W F TC=0+100	24546	C4-1/8-T0=101-F
A5R102	0757-0402	1	4	RESISTOR 110 1X .125W F TC=0+100	24546	C4-1/8-T0=111-F
A5R103	0698-4453	4	10	RESISTOR 402 1X .125W F TC=0+100	24546	C4-1/8-T0=402R-F
A5R105	0757-0416	7		RESISTOR 511 1X .125W F TC=0+100	24546	C4-1/8-T0=511R-F
A5R106	0757-0416	7		RESISTOR 511 1X .125W F TC=0+100	24546	C4-1/8-T0=511R-F
A5R107	0757-0725	1	1	RESISTOR 475 1X .25W F TC=0+100	24546	C5-1/4-T0=475R-F
A5R108	0757-0410	1	4	RESISTOR 301 1X .125W F TC=0+100	24546	C4-1/8-T0=301R-F
A5R109	0757-0410	1		RESISTOR 301 1X .125W F TC=0+100	24546	C4-1/8-T0=301R-F
A5R110	0757-0401	0		RESISTOR 100 1X .125W F TC=0+100	24546	C4-1/8-T0=101-F
A5R111	0698-7188	8		RESISTOR 10 1X .05W F TC=0+100	24546	C3-1/8-T00=10R-G
A5R112	0757-0438	3		RESISTOR 5.11K 1X .125W F TC=0+100	24546	C4-1/8-T0=5111-F
A5R115	2100-0567	0	1	RESISTOR-TRMR 2K 10X C TOP-ADJ 1-TRN	28480	2100-0567
A5R116	0698-3154	0	4	RESISTOR 4.22K 1X .125W F TC=0+100	24546	C4-1/8-T0=4221-F
A5R117	0698-3540	9	3	R-FXD 15.4K 1%	24546	C4-1/8-T0=4222-F
A5R118	0757-0273	4		RESISTOR 3.01K 1X .125W F TC=0+100	24546	C4-1/8-T0=3011-F
A5R119	0698-0085	0	3	RESISTOR 2.61K 1X .125W F TC=0+100	24546	C4-1/8-T0=2611-F
A5R120	0757-0407	6		RESISTOR 200 1X .125W F TC=0+100	24546	C4-1/8-T0=201-F
A5R121	0757-0805	8	2	RESISTOR 221 1X .5W F TC=0+100	28480	0757-0805
A5R122	0698-3495	2	2	RESISTOR 866 1X .125W F TC=0+100	24546	C4-1/8-T0=866R-F
A5R123	0757-0410	1		RESISTOR 301 1X .125W F TC=0+100	24546	C4-1/8-T0=301R-F
A5R124	0757-0442	9		RESISTOR 10K 1X .125W F TC=0+100	24546	C4-1/8-T0=1002-F

Table 6-3. Replaceable Parts (cont'd)

Reference Designation	HP Part Number	C D	Qty	Description	Mfr Code	Mfr Part Number
A5R125	0757-0449	6		RESISTOR 20K 1% .125W F TC=0+-100	24546	C4-1/8-T0-2002-F
A5R126	0757-0438	3		RESISTOR 5.11K 1% .125W F TC=0+-100	24546	C4-1/8-T0-5111-F
A5R201	0757-0384	8		RESISTOR 20 1% .125W F TC=0+-100	19701	MF4C1/8-T0-20R0-F
A5R202	0698-3178	8		RESISTOR 487 1% .125W F TC=0+-100	24546	C4-1/8-T0-487R-F
A5R203	0757-0280	3		RESISTOR 1K 1% .125W F TC=0+-100	24546	C4-1/8-T0-1001-F
A5R204	0757-0401	0		RESISTOR 100 1% .125W F TC=0+-100	24546	C4-1/8-T0-101-F
A5R205	0757-0394	0		RESISTOR 51.1 1% .125W F TC=0+-100	24546	C4-1/8-T0-51R1-F
A5R207	0757-0410	1		RESISTOR 301 1% .125W F TC=0+-100	24546	C4-1/8-T0-301R-F
A5R208	0757-0401	0		RESISTOR 100 1% .125W F TC=0+-100	24546	C4-1/8-T0-101-F
A5R209	0698-3178	8		RESISTOR 487 1% .125W F TC=0+-100	24546	C4-1/8-T0-487R-F
A5R210	0757-0280	3		RESISTOR 1K 1% .125W F TC=0+-100	24546	C4-1/8-T0-1001-F
A5R211	0757-0419	0	11	RESISTOR 681 1% .125W F TC=0+-100	24546	C4-1/8-T0-681R-F
A5R212	0757-0419	0		RESISTOR 681 1% .125W F TC=0+-100	24546	C4-1/8-T0-681R-F
A5R213	0757-0407	8		RESISTOR 200 1% .125W F TC=0+-100	24546	C4-1/8-T0-201-F
A5R214	0698-4423	8	2	RESISTOR 1.37K 1% .125W F TC=0+-100	24546	C4-1/8-T0-1371-F
A5R215	0757-0346	2		RESISTOR 10 1% .125W F TC=0+-100	24546	C4-1/8-T0-10R0-F
A5R216	0757-0805	8		RESISTOR 221 1% .5W F TC=0+-100	24480	0757-0805
A5R217	0698-3258	5	2	RESISTOR 5.36K 1% .125W F TC=0+-100	24546	C4-1/8-T0-5361-F
A5R218	0698-4423	8		RESISTOR 1.37K 1% .125W F TC=0+-100	24546	C4-1/8-T0-1371-F
A5R219	0757-0407	6		RESISTOR 200 1% .125W F TC=0+-100	24546	C4-1/8-T0-201-F
A5R220	0757-0346	2		RESISTOR 10 1% .125W F TC=0+-100	24546	C4-1/8-T0-10R0-F
A5R221	0757-0394	0		RESISTOR 51.1 1% .125W F TC=0+-100	24546	C4-1/8-T0-51R1-F
A5R223	0757-0394	0		RESISTOR 51.1 1% .125W F TC=0+-100	24546	C4-1/8-T0-51R1-F
A5R224	0757-0394	0		RESISTOR 51.1 1% .125W F TC=0+-100	24546	C4-1/8-T0-51R1-F
A5R225	0757-0438	3		RESISTOR 5.11K 1% .125W F TC=0+-100	24546	C4-1/8-T0-5111-F
A5R228	0757-0407	6		RESISTOR 200 1% .125W F TC=0+-100	24546	C4-1/8-T0-201-F
A5R229	0757-0280	3		RESISTOR 1K 1% .125W F TC=0+-100	24546	C4-1/8-T0-1001-F
A5R231	0698-3447	4		RESISTOR 422 1% .125W F TC=0+-100	24546	C4-1/8-T0-422R-F
A5R232	0757-0407	6		RESISTOR 200 1% .125W F TC=0+-100	24546	C4-1/8-T0-201-F
A5R233	0757-0424	7	3	RESISTOR 1.1K 1% .125W F TC=0+-100	24546	C4-1/8-T0-1101-F
A5R234	0757-0395	1	1	RESISTOR 56.2 1% .125W F TC=0+-100	24546	C4-1/8-T0-56R2-F
A5R235	2100-2060	2		RESISTOR-TRMR 50 20% C TOP-ADJ 1-TRN	73138	R2PR50
A5R236	0757-0401	0		RESISTOR 100 1% .125W F TC=0+-100	24546	C4-1/8-T0-101-F
A5R237	0698-3159	5	3	RESISTOR 26.1K 1% .125W F TC=0+-100	24546	C4-1/8-T0-2612-F
A5R238	0757-0438	3		RESISTOR 5.11K 1% .125W F TC=0+-100	24546	C4-1/8-T0-5111-F
A5R239	0757-0454	3	7	RESISTOR 33.2K 1% .125W F TC=0+-100	24546	C4-1/8-T0-3322-F
A5R241	0757-0449	6		RESISTOR 20K 1% .125W F TC=0+-100	24546	C4-1/8-T0-2002-F
A5R242	0757-0290	5		RESISTOR 6.19K 1% .125W F TC=0+-100	19701	MF4C1/8-T0-6191-F
A5R244	0698-4424	9		RESISTOR 1.4K 1% .125W F TC=0+-100	24546	C4-1/8-T0-1401-F
A5R245	0757-0283	6		RESISTOR 2K 1% .125W F TC=0+-100	24546	C4-1/8-T0-2001-F
A5R246	0757-0407	6		RESISTOR 200 1% .125W F TC=0+-100	24546	C4-1/8-T0-201-F
A5R247	0757-0801	4	1	RESISTOR 150 1% .5W F TC=0+-100	28480	0757-0801
A5R248	0698-4408	9	1	RESISTOR 124 1% .125W F TC=0+-100	24546	C4-1/8-T0-124R-F
A5R301	0698-3374	6	2	RESISTOR 20 5% .125W CC TC=-270/+540	01121	BR3005
A5R302	0757-0458	7		RESISTOR 51.1K 1% .125W F TC=0+-100	24546	C4-1/8-T0-5112-F
A5R303	0698-7212	9	6	RESISTOR 100 1% .05W F TC=0+-100	24546	C3-1/8-T0-100R-G
A5R304	0698-4413	6		RESISTOR 154 1% .125W F TC=0+-100	24546	C4-1/8-T0-154R-F
A5R305	0698-4413	6		RESISTOR 154 1% .125W F TC=0+-100	24546	C4-1/8-T0-154R-F
A5R306	0698-3111	9		RESISTOR 30 5% .125W CC TC=-270/+540	01121	BR3005
A5R307	0698-7223	2	10	RESISTOR 287 1% .05W F TC=0+-100	24546	C3-1/8-T0-287R-G
A5R308	0698-7223	2		RESISTOR 287 1% .05W F TC=0+-100	24546	C3-1/8-T0-287R-G
A5R309	0698-4429	4	2	RESISTOR 1.87K 1% .125W F TC=0+-100	24546	C4-1/8-T0-1871-F
A5R310	0698-7212	9		RESISTOR 100 1% .05W F TC=0+-100	24546	C3-1/8-T0-100R-G
A5R311	0698-4409	0	3	RESISTOR 127 1% .125W F TC=0+-100	24546	C4-1/8-T0-127R-F
A5R312	0698-4409	0		RESISTOR 127 1% .125W F TC=0+-100	24546	C4-1/8-T0-127R-F
A5R313	0698-3111	9		RESISTOR 30 5% .125W CC TC=-270/+540	01121	BR3005
A5R314	0698-7223	2		RESISTOR 287 1% .05W F TC=0+-100	24546	C3-1/8-T0-287R-G
A5R315	0698-7223	2		RESISTOR 287 1% .05W F TC=0+-100	24546	C3-1/8-T0-287R-G
A5R316	0757-0421	4		RESISTOR 825 1% .125W F TC=0+-100	24546	C4-1/8-T0-825R-F
A5R317	0698-7212	9		RESISTOR 100 1% .05W F TC=0+-100	24546	C3-1/8-T0-100R-G
A5R318	0698-4406	7	2	RESISTOR 115 1% .125W F TC=0+-100	24546	C4-1/8-T0-115R-F
A5R319	0698-4406	7		RESISTOR 115 1% .125W F TC=0+-100	24546	C4-1/8-T0-115R-F
A5R320	0698-3111	9		RESISTOR 30 5% .125W CC TC=-270/+540	01121	BR3005
A5R321	0698-7223	2		RESISTOR 287 1% .05W F TC=0+-100	24546	C3-1/8-T0-287R-G
A5R322	0698-7223	2		RESISTOR 287 1% .05W F TC=0+-100	24546	C3-1/8-T0-287R-G
A5R323	0757-0418	9		RESISTOR 619 1% .125W F TC=0+-100	24546	C4-1/8-T0-619R-F
A5R324	0698-7212	9		RESISTOR 100 1% .05W F TC=0+-100	24546	C3-1/8-T0-100R-G
A5R325	0698-3132	4		RESISTOR 261 1% .125W F TC=0+-100	24546	C4-1/8-T0-2610-F
A5R326	0698-3132	4		RESISTOR 261 1% .125W F TC=0+-100	24546	C4-1/8-T0-2610-F
A5R327	0698-3111	9		RESISTOR 30 5% .125W CC TC=-270/+540	01121	BR3005
A5R328	0698-7223	2		RESISTOR 287 1% .05W F TC=0+-100	24546	C3-1/8-T0-287R-G
A5R329	0698-7223	2		RESISTOR 287 1% .05W F TC=0+-100	24546	C3-1/8-T0-287R-G
A5R330	0698-3518	0	1	RESISTOR 7.32K 1% .125W F TC=0+-100	24546	C4-1/8-T0-7321-F
A5R331	0698-7212	9		RESISTOR 100 1% .05W F TC=0+-100	24546	C3-1/8-T0-100R-G
A5R332	0698-4411	4	3	RESISTOR 140 1% .125W F TC=0+-100	24546	C4-1/8-T0-140R-F

Table 6-3. Replaceable Parts (cont'd)

Reference Designation	HP Part Number	C D	Qty	Description	Mfr Code	Mfr Part Number
ASR333	0698-4411	4		RESISTOR 140 1X .125W F TC=0+-100	2454b	C4=1/8-T0=140W-F
ASR334	0698-3111	9		RESISTOR 30 5X .125W CC TC=-270/+540	01121	BB3005
ASR335	0698-7223	2		RESISTOR 287 1X .05W F TC=0+-100	2454b	C3=1/8-T0=287W-G
ASR336	0698-7223	2		RESISTOR 287 1X .05W F TC=0+-100	2454b	C3=1/8-T0=287R-G
ASR337	0698-4468	1	1	RESISTOR 1.13K 1X .125W F TC=0+-100	2454b	C4=1/8-T0=1131-F
ASR338	0698-4422	7		RESISTOR 1.27K 1X .125W F TC=0+-100	2454b	C4=1/8-T0=1271-F
ASR339	0757-0273	4		RESISTOR 3.01K 1X .125W F TC=0+-100	2454b	C4=1/8-T0=3011-F
ASR341	0757-0438	3		RESISTOR 5.11K 1X .125W F TC=0+-100	2454b	C4=1/8-T0=5111-F
ASR342	0698-7238	9	1	RESISTOR 1.21K 1X .05W F TC=0+-100	2454b	C3=1/8-T0=1211-G
ASR343	0698-7212	9		RESISTOR 100 1X .05W F TC=0+-100	2454b	C3=1/8-T0=100R-G
ASR344	0757-0402	1		RESISTOR 110 1X .125W F TC=0+-100	2454b	C4=1/8-T0=111-F
ASR345	0698-3202	9	1	RESISTOR 1.74K 1X .125W F TC=0+-100	2454b	C4=1/8-T0=1741-F
ASR346	0757-0394	0		RESISTOR 51.1 1X .125W F TC=0+-100	2454b	C4=1/8-T0=51R1-F
ASR347	0757-0274	5		RESISTOR 1.21K 1X .125W F TC=0+-100	2454b	C4=1/8-T0=1213-F
ASR348	0757-0407	6		RESISTOR 200 1X .125W F TC=0+-100	2454b	C4=1/8-T0=201-F
ASR349	0698-4428	3		RESISTOR 1.69K 1X .125W F TC=0+-100	2454b	C4=1/8-T0=1691-F
ASR351	0698-4425	0		RESISTOR 1.54K 1X .125W F TC=0+-100	2454b	C4=1/8-T0=1541-F
ASR352	0757-0280	3		RESISTOR 1K 1X .125W F TC=0+-100	2454b	C4=1/8-T0=1001-F
ASR353	0698-3178	8		RESISTOR 487 1X .125W F TC=0+-100	2454b	C4=1/8-T0=487R-F
ASR354	0698-3178	8		RESISTOR 487 1X .125W F TC=0+-100	2454b	C4=1/8-T0=487R-F
ASR355	0757-0407	6		RESISTOR 200 1X .125W F TC=0+-100	2454b	C4=1/8-T0=201-F
ASR356	0698-3437	2		RESISTOR 133 1X .125W F TC=0+-100	2454b	C4=1/8-T0=133R-F
ASR357	0698-4386	2	2	RESISTOR 59 1X .125W F TC=0+-100	2454b	C4=1/8-T0=59R0-F
ASR358	0698-4386	2		RESISTOR 59 1X .125W F TC=0+-100	2454b	C4=1/8-T0=59R0-F
ASR359	0698-7229	8	2	RESISTOR 511 1X .05W F TC=0+-100	2454b	C3=1/8-T0=511R-G
ASR361	0698-7229	8		RESISTOR 511 1X .05W F TC=0+-100	2454b	C3=1/8-T0=511R-G
ASR362	0757-0401	0		RESISTOR 100 1X .125W F TC=0+-100	2454b	C4=1/8-T0=101-F
ASR363	0757-0346	2		RESISTOR 10 1X .125W F TC=0+-100	2454b	C4=1/8-T0=10R0-F
ASR364	0757-0401	0		RESISTOR 100 1X .125W F TC=0+-100	2454b	C4=1/8-T0=101-F
ASR365	0757-0401	0		RESISTOR 100 1X .125W F TC=0+-100	2454b	C4=1/8-T0=101-F
ASR366	0757-0438	3		RESISTOR 5.11K 1X .125W F TC=0+-100	2454b	C4=1/8-T0=5111-F
ASR367	0698-3442	9		RESISTOR 237 1X .125W F TC=0+-100	2454b	C4=1/8-T0=237R-F
ASR401	0698-3111	9		RESISTOR 30 5X .125W CC TC=-270/+540	01121	BB3005
ASR402	0757-0274	5		RESISTOR 1.21K 1X .125W F TC=0+-100	2454b	C4=1/8-T0=1213-F
ASR403	0698-3111	9		RESISTOR 30 5X .125W CC TC=-270/+540	01121	BB3005
ASR404	0698-3374	6		RESISTOR 20 5X .125W CC TC=-270/+540	01121	BB2005
ASR405	0757-1094	9		RESISTOR 1.47K 1X .125W F TC=0+-100	2454b	C4=1/8-T0=1471-F
ASR406	0757-0402	1		RESISTOR 110 1X .125W F TC=0+-100	2454b	C4=1/8-T0=111-F
ASR407	0757-0402	1		RESISTOR 110 1X .125W F TC=0+-100	2454b	C4=1/8-T0=111-F
ASR408	0698-4422	7		RESISTOR 1.27K 1X .125W F TC=0+-100	2454b	C4=1/8-T0=1271-F
ASR409	0757-0401	0		RESISTOR 100 1X .125W F TC=0+-100	2454b	C4=1/8-T0=101-F
ASR410	0757-0401	0		RESISTOR 100 1X .125W F TC=0+-100	2454b	C4=1/8-T0=101-F
ASR411	0698-4037	0	6	RESISTOR 46.4 1X .125W F TC=0+-100	2454b	C4=1/8-T0=46R4-F
ASR412	0698-4037	0		RESISTOR 46.4 1X .125W F TC=0+-100	2454b	C4=1/8-T0=46R4-F
ASR413	0698-7205	0		RESISTOR 51.1 1X .05W F TC=0+-100	2454b	C3=1/8-T0=51R1-G
ASR414	0698-7205	0		RESISTOR 51.1 1X .05W F TC=0+-100	2454b	C3=1/8-T0=51R1-G
ASR415	0698-4037	0		RESISTOR 46.4 1X .125W F TC=0+-100	2454b	C4=1/8-T0=46R4-F
ASR416	0698-4037	0		RESISTOR 46.4 1X .125W F TC=0+-100	2454b	C4=1/8-T0=46R4-F
ASR417	0757-0388	2		RESISTOR 30.1 1X .125W F TC=0+-100	2454b	C4=1/8-T0=30R1-F
ASR418	0757-0394	0		RESISTOR 51.1 1X .125W F TC=0+-100	2454b	C4=1/8-T0=51R1-F
ASR419	0698-4383	2		RESISTOR 53.6 1X .125W F TC=0+-100	2454b	C4=1/8-T0=53R6-F
ASR420	0698-4383	9		RESISTOR 53.6 1X .125W F TC=0+-100	2454b	C4=1/8-T0=53R6-F
ASR421	0698-0271	7	1	RESISTOR 2.7 10X .25W FC TC=400/+500	01121	CR27G1
ASR425	0698-4428	3		RESISTOR 1.69K 1X .125W F TC=0+-100	2454b	C4=1/8-T0=1691-F
ASR426	0698-4458	9		RESISTOR 590 1X .125W F TC=0+-100	2454b	C4=1/8-T0=590R-F
ASR427	0698-3258	5		RESISTOR 5.36K 1X .125W F TC=0+-100	2454b	C4=1/8-T0=5361-F
ASR428	0757-0407	6		RESISTOR 200 1X .125W F TC=0+-100	2454b	C4=1/8-T0=201-F
ASR429	0698-4428	3		RESISTOR 1.69K 1X .125W F TC=0+-100	2454b	C4=1/8-T0=1691-F
ASR431	0757-0274	5		RESISTOR 1.21K 1X .125W F TC=0+-100	2454b	C4=1/8-T0=1213-F
ASR432	0757-0394	0		RESISTOR 51.1 1X .125W F TC=0+-100	2454b	C4=1/8-T0=51R1-F
ASR501	0757-0449	6		RESISTOR 20K 1X .125W F TC=0+-100	2454b	C4=1/8-T0=2002-F
ASR502	0757-0449	6		RESISTOR 20K 1X .125W F TC=0+-100	2454b	C4=1/8-T0=2002-F
ASR503	0757-0449	6		RESISTOR 20K 1X .125W F TC=0+-100	2454b	C4=1/8-T0=2002-F
ASR504	0757-0438	3		RESISTOR 5.11K 1X .125W F TC=0+-100	2454b	C4=1/8-T0=5111-F
ASR505	0757-0438	3		RESISTOR 5.11K 1X .125W F TC=0+-100	2454b	C4=1/8-T0=5111-F
ASR506	0757-0442	9		RESISTOR 10K 1X .125W F TC=0+-100	2454b	C4=1/8-T0=1002-F
ASR507	0757-0442	9		RESISTOR 10K 1X .125W F TC=0+-100	2454b	C4=1/8-T0=1002-F
ASR508	0757-0442	9		RESISTOR 10K 1X .125W F TC=0+-100	2454b	C4=1/8-T0=1002-F
ASR509	0698-4428	3		RESISTOR 1.69K 1X .125W F TC=0+-100	2454b	C4=1/8-T0=1691-F
ASR510	0698-3136	8	9	RESISTOR 17.8K 1X .125W F TC=0+-100	2454b	C4=1/8-T0=1782-F
ASR511	0757-0283	6		RESISTOR 2K 1X .125W F TC=0+-100	2454b	C4=1/8-T0=2001-F
ASR512	0757-0421	4		RESISTOR 825 1X .125W F TC=0+-100	2454b	C4=1/8-T0=825R-F
ASR513	0757-0442	9		RESISTOR 10K 1X .125W F TC=0+-100	2454b	C4=1/8-T0=1002-F
ASR514	0698-3499	6		RESISTOR 40.2K 1X .125W F TC=0+-100	2454b	C4=1/8-T0=4022-F
ASR515	0757-0442	9		RESISTOR 10K 1X .125W F TC=0+-100	2454b	C4=1/8-T0=1002-F

Table 6-3. Replaceable Parts (cont'd)

Reference Designation	HP Part Number	C D	Qty	Description	Mfr Code	Mfr Part Number
ASR516	069A-4453	4		RESISTOR 402 1% .125W F TC0+100	24546	C4=1/8-T0=402R-F
ASR517	0757-02A0	3	3	RESISTOR 1K 1% .125W F TC0+100	24546	C4=1/8-T0=1001-F
ASR51A	06A3-1065	7		RESISTOR 10M 5% .25W FC TC=900/+1100	01121	CB1065
ASR520	069A-71A8	8		RESISTOR 10 1% .05W F TC0+100	24546	C3=1/8-T0=104-G
ASR521	0757-02B0	3		RESISTOR 1K 1% .125W F TC0+100	24546	C4=1/8-T0=1001-F
ASR519	0683-1065	4		R-FXD 10M 5% .25W		
ASR523	069A-71A8	A		RESISTOR 10 1% .05W F TC0+100	24546	C3=1/8-T0=104-G
ASR524	0757-02A0	3		RESISTOR 1K 1% .125W F TC0+100	24546	C4=1/8-T0=1001-F
ASR525	0757-0438	3		RESISTOR 5.11K 1% .125W F TC0+100	24546	C4=1/8-T0=5111-F
ASR526	0757-0438	3		RESISTOR 5.11K 1% .125W F TC0+100	24546	C4=1/8-T0=5111-F
ASR527	0757-0442	9		RESISTOR 10K 1% .125W F TC0+100	24546	C4=1/8-T0=102-F
ASR52A	0757-0442	9		RESISTOR 10K 1% .125W F TC0+100	24546	C4=1/8-T0=102-F
ASR529	0757-0442	9		RESISTOR 10K 1% .125W F TC0+100	24546	C4=1/8-T0=102-F
ASR601	0757-0442	9		RESISTOR 10K 1% .125W F TC0+100	24546	C4=1/8-T0=102-F
ASR602	0757-02B0	3		RESISTOR 1K 1% .125W F TC0+100	24546	C4=1/8-T0=1001-F
ASR603	0757-02A0	3		RESISTOR 1K 1% .125W F TC0+100	24546	C4=1/8-T0=1001-F
ASR701	1810-0049	7	2	NETWORK-RES 12-81P6.8K OHM X 10	28480	1810-0049
ASR702	1810-0049	7		NETWORK-RES 12-81P6.8K OHM X 10	28480	1810-0049
ASRT1	0837-0085	6	1	THERMISTOR WOD 680-OHM TC=+.7%/C-DEG	28480	0837-0085
ASU1	1826-0059	2	9	IC OP AMP GP TO-99	01295	LM201AL
ASU2	1826-0059	2		IC OP AMP GP TO-99	01295	LM201AL
ASU3	1826-0059	2		IC OP AMP GP TO-99	01295	LM201AL
ASU4	1826-0147	9	1	IC 7A12 V RGLTR TO-220	04713	MC7812CP
ASU5	1826-0315	3		IC OP AMP GP QUAD 14-DIP-P	27014	LM348N
ASU6	1826-0043	4		IC OP AMP GP TO-99	01928	CA307T
ASU101	1820-0802	1	A	IC GATE ECL NOR QUAD 2-IMP	04713	MC10102P
ASU201	1820-0751	9	1	IC CNTR TTL DECD NEG-EDGE-TRIG PRESET	01295	SN74196N
ASU202	1820-0802	1		IC GATE ECL NOR QUAD 2-IMP	04713	MC10102P
ASU301	185A-0040	8	3	TRANSISTOR ARRAY	01928	CA3127E
ASU302	185B-0040	8		TRANSISTOR ARRAY	01928	CA3127E
ASU303	185B-0040	8		TRANSISTOR ARRAY	01928	CA3127E
ASU304	1826-0043	4		IC OP AMP GP TO-99	01928	CA307T
ASU305	1826-0043	4		IC OP AMP GP TO-99	01928	CA307T
ASU306	1826-0111	7	11	IC OP AMP GP DUAL TO-99	04713	MC14586
ASU401	1858-0030	6	1	TRANSISTOR ARRAY 16-PIN CER DIP	28480	1858-0030
ASU402	1826-0111	7		IC OP AMP GP DUAL TO-99	04713	MC14586
ASU601	1826-0081	0	1	IC OP AMP WR TO-99	27014	LM318M
ASVR1	1902-3024	9	2	DIODE-ZNR 2.87V 5% DO-7 PDS.4W TC=+.07%	28480	1902-3024
ASVR2	1902-0032	3	3	DIODE-ZNR 5.49V 5% DO-7 PDS.4W TC=+.009%	28480	1902-0032
ASVR3	1902-0032	3		DIODE-ZNR 5.49V 5% DO-7 PDS.4W TC=+.009%	28480	1902-0032
ASVR4	1902-0032	3		DIODE-ZNR 5.49V 5% DO-7 PDS.4W TC=+.009%	28480	1902-0032
ASVR5	1902-3024	9		DIODE-ZNR 2.87V 5% DO-7 PDS.4W TC=+.07%	28480	1902-3024
ASVR6	1902-3094	3		DIODE-ZNR 5.11V 2% DO-7 PDS.4W TC=+.009%	28480	1902-3094
ASVR7	1902-0692	1	1	DIODE-ZNR 6.3V 1% DO-7 PDS.4W TC=+.001%	28480	1902-0692
ASVR8	1902-3002	3	1	DIODE-ZNR 2.37V 5% DO-7 PDS.4W TC=+.074%	28480	1902-3002
ASVR9	1902-0685	2	1	DIODE-ZNR 9V 2% DO-7 PDS.5W TC=+.001%	28480	1902-0685
ASVR101	1902-0048	1		DIODE-ZNR 6.81V 5% DO-7 PDS.4W TC=+.043%	28480	1902-0048
ASVR102	1902-0041	4	6	DIODE-ZNR 5.11V 5% DO-7 PDS.4W TC=+.009%	28480	1902-0041
ASVR103	1902-3149	9	1	DIODE-ZNR 9.09V 5% DO-7 PDS.4W TC=+.057%	28480	1902-3149
ASVR104	1902-0126	6	3	DIODE-ZNR 2.61V 5% DO-7 PDS.4W TC=+.072%	28480	1902-0126
ASVR201	1902-0126	6		DIODE-ZNR 2.61V 5% DO-7 PDS.4W TC=+.072%	28480	1902-0126
ASVR202	1902-0126	6		DIODE-ZNR 2.61V 5% DO-7 PDS.4W TC=+.072%	28480	1902-0126
ASVR203	1902-07A6	4	7	DIODE-ZNR 1N937 9V 5% DO-7 PDS.5W	24046	1N937
ASVR301	1902-07B6	4		DIODE-ZNR 1N937 9V 5% DO-7 PDS.5W	24046	1N937
ASVR302	1902-07A6	4		DIODE-ZNR 1N937 9V 5% DO-7 PDS.5W	24046	1N937
ASVR401	1902-3094	3		DIODE-ZNR 5.11V 2% DO-7 PDS.4W TC=+.009%	28480	1902-3094
ASVR402	1902-0777	3	2	DIODE-ZNR 1N825 6.2V 5% DO-7 PDS.4W	04713	1N825
A6	08165-66506	9	1	BOARD ASSEMBLY, POWER CONTROL	28480	08165-66506
A6C101	0160-3650	2	1	CAPACITOR-FXD .018UF +-10% 50VDC CER	28480	0160-3650
A6C102	0160-0174	9		CAPACITOR-FXD .47UF +80-20% 25VDC CER	28480	0160-0174
A6C103	0160-2265	3	1	CAPACITOR-FXD 22PF +-5% 500VDC CER 0+-30	28480	0160-2265
A6C104	0160-3879	7		CAPACITOR-FXD .01UF +-20% 100VDC CER	28480	0160-3879
A6C105	0160-1704	5		CAPACITOR-FXD 47UF+-10% 6VDC TA	56289	150D476X900682
A6C201	0160-0174	9		CAPACITOR-FXD .47UF +80-20% 25VDC CER	28480	0160-0174
A6C202	0160-1704	5		CAPACITOR-FXD 47UF+-10% 6VDC TA	56289	150D476X900682
A6C301	0160-0174	9		CAPACITOR-FXD .47UF +80-20% 25VDC CER	28480	0160-0174
A6C302	0160-2257	3	3	CAPACITOR-FXD 10PF +-5% 500VDC CER 0+-60	28480	0160-2257
A6C303	0160-0116	1	5	CAPACITOR-FXD 6.8UF+-10% 35VDC TA	56289	150D685X903582
A6C401	0160-0174	9		CAPACITOR-FXD .47UF +80-20% 25VDC CER	28480	0160-0174
A6C402	0160-2257	3		CAPACITOR-FXD 10PF +-5% 500VDC CER 0+-60	28480	0160-2257
A6C403	0160-0116	1		CAPACITOR-FXD 6.8UF+-10% 35VDC TA	56289	150D685X903582
A6C501	0160-2055	9		CAPACITOR-FXD .01UF +80-20% 100VDC CER	28480	0160-2055
A6C502	0160-0291	3	1	CAPACITOR-FXD 1UF+-10% 35VDC TA	56289	150D105X9035A2

Table 6-3. Replaceable Parts (cont'd)

Reference Designation	HP Part Number	C D	Qty	Description	Mfr Code	Mfr Part Number
A6C503	0160-0229	7		CAPACITOR-FXD 33UF +-10% 10VDC TA	56289	150D336X901082
A6C505	0160-0174	9		CAPACITOR-FXD .47UF +80-20% 25VDC CER	28480	0160-0174
A6C506	0160-0174	9		CAPACITOR-FXD .47UF +80-20% 25VDC CER	28480	0160-0174
A6C601	0160-0174	9		CAPACITOR-FXD .47UF +80-20% 25VDC CER	28480	0160-0174
A6C602	0160-2150	5		CAPACITOR-FXD 33PF +-5% 300VDC MICA	28480	0160-2150
A6C603	0160-4212	4		CAPACITOR-FXD .068UF +-20% 50VDC POLYE	28480	0160-4212
A6CR01	0100-0196	3		CAPACITOR-FXD 150PF +-5% 300VDC MICA	72136	DM15F151J0300MVICR
A6CR101	1901-0040	1		DIODE-SWITCHING 30V 50MA 2NS DO-35	28480	1901-0040
A6CR201	1901-0040	1		DIODE-SWITCHING 30V 50MA 2NS DO-35	28480	1901-0040
A6CR301	1901-0040	1		DIODE-SWITCHING 30V 50MA 2NS DO-35	28480	1901-0040
A6CR401	1901-0040	1		DIODE-SWITCHING 30V 50MA 2NS DO-35	28480	1901-0040
A6CR501	1901-0044	5	23	DIODE-SWITCHING 50V 50MA 6NS	28480	1901-0044
A6CR502	1901-0044	5		DIODE-SWITCHING 50V 50MA 6NS	28480	1901-0044
A6CR503	1901-0044	5		DIODE-SWITCHING 50V 50MA 6NS	28480	1901-0044
A6CR504	1901-0044	5		DIODE-SWITCHING 50V 50MA 6NS	28480	1901-0044
A6CR505	1901-0044	5		DIODE-SWITCHING 50V 50MA 6NS	28480	1901-0044
A6CR506	1901-0050	3		DIODE-SWITCHING 80V 200MA 2NS DO-35	28480	1901-0050
A6CR507	1901-0050	3		DIODE-SWITCHING 80V 200MA 2NS DO-35	28480	1901-0050
A6CR601	1901-0044	5		DIODE-SWITCHING 50V 50MA 6NS	28480	1901-0044
A6CR602	1901-0044	5		DIODE-SWITCHING 50V 50MA 6NS	28480	1901-0044
A6CR603	1901-0044	5		DIODE-SWITCHING 50V 50MA 6NS	28480	1901-0044
A6CR604	1901-0044	5		DIODE-SWITCHING 50V 50MA 6NS	28480	1901-0044
A6CR801	1901-0040	1		DIODE-SWITCHING 30V 50MA 2NS DO-35	28480	1901-0040
A6CR802	1901-0040	1		DIODE-SWITCHING 30V 50MA 2NS DO-35	28480	1901-0040
A6CR803	1901-0040	1		DIODE-SWITCHING 30V 50MA 2NS DO-35	28480	1901-0040
A6CR804	1901-0040	1		DIODE-SWITCHING 30V 50MA 2NS DO-35	28480	1901-0040
A6CR805	1901-0040	1		DIODE-SWITCHING 30V 50MA 2NS DO-35	28480	1901-0040
A6MP1	1205-0284	9	1	HEAT SINK PLSTC-PWR-C8	28480	1205-0284
A6MP2	4040-0753	0	1	EXTR-PC BD GRN POLYC .062-BD=THKNS	28480	4040-0753
A6Q101	1853-0212	6	1	TRANSISTOR PNP 2N5194 SI PD=40W FT=2MHZ	04713	2N5194
A6Q102	1854-0477	7		TRANSISTOR NPN 2N2222A SI TO-18 PD=500MW	04713	2N2222A
A6Q201	1853-0281	9		TRANSISTOR PNP 2N2907A SI TO-18 PD=400MW	04713	2N2907A
A6Q301	1854-0637	1		TRANSISTOR NPN 2N2219A SI TO-5 PD=800MW	01295	2N2219A
A6Q401	1853-0314	9		TRANSISTOR PNP 2N2905A SI TO-39 PD=600MW	04713	2N2905A
A6Q501	1854-0637	1		TRANSISTOR NPN 2N2219A SI TO-5 PD=800MW	01295	2N2219A
A6Q502	1853-0314	9		TRANSISTOR PNP 2N2905A SI TO-39 PD=600MW	04713	2N2905A
A6Q503	1854-0477	7		TRANSISTOR NPN 2N2222A SI TO-18 PD=500MW	04713	2N2222A
A6Q504	1853-0281	9		TRANSISTOR PNP 2N2907A SI TO-18 PD=400MW	04713	2N2907A
A6Q601	1853-0036	2		TRANSISTOR PNP SI PD=310MW FT=250MHZ	28480	1853-0036
A6Q602	1853-0036	2		TRANSISTOR PNP SI PD=310MW FT=250MHZ	28480	1853-0036
A6Q603	1853-0036	2		TRANSISTOR PNP SI PD=310MW FT=250MHZ	28480	1853-0036
A6Q604	1855-0081	1	7	TRANSISTOR J-FET N-CHAN D-MODE SI	01295	2N5245
A6Q605	1855-0081	1		TRANSISTOR J-FET N-CHAN D-MODE SI	01295	2N5245
A6Q606	1855-0081	1		TRANSISTOR J-FET N-CHAN D-MODE SI	01295	2N5245
A6Q607	1854-0472	2		TRANSISTOR NPN SI DARL PD=500MW	04713	MP8-A14
A6Q801	1853-0400	4	6	TRANSISTOR PNP SI DARL TO-92 PD=500MW	28480	1853-0400
A6Q802	1853-0036	2		TRANSISTOR PNP SI PD=310MW FT=250MHZ	28480	1853-0036
A6Q803	1853-0036	2		TRANSISTOR PNP SI PD=310MW FT=250MHZ	28480	1853-0036
A6Q804	1854-0215	1		TRANSISTOR NPN SI PD=350MW FT=300MHZ	04713	2N3904
A6Q906	1853-0400	4		TRANSISTOR PNP SI DARL TO-92 PD=500MW	28480	1853-0400
A6Q907	1853-0400	4		TRANSISTOR PNP SI DARL TO-92 PD=500MW	28480	1853-0400
A6Q908	1853-0086	2		TRANSISTOR PNP SI PD=310MW FT=400MHZ	27014	2N5087
A6Q909	1853-0281	9		TRANSISTOR PNP 2N2907A SI TO-18 PD=400MW	04713	2N2907A
A6Q910	1853-0400	4		TRANSISTOR PNP SI DARL TO-92 PD=500MW	28480	1853-0400
A6Q911	1853-0086	2		TRANSISTOR PNP SI PD=310MW FT=400MHZ	27014	2N5087
A6Q912	1854-0637	1		TRANSISTOR NPN 2N2219A SI TO-5 PD=800MW	01295	2N2219A
A6Q913	1853-0281	9		TRANSISTOR PNP 2N2907A SI TO-18 PD=400MW	04713	2N2907A
A6R1	2100-3053	5	2	RESISTOR-TRMR 20 20% C SIDE-ADJ 17-TRN	02111	43P200
A6R2	2100-3053	5		RESISTOR-TRMR 20 20% C SIDE-ADJ 17-TRN	02111	43P200
A6R101	0757-0280	3		RESISTOR 1K 1% .125W F TC=0+-100	24546	C4-1/8-T0=1001-F
A6R102	0757-0280	3		RESISTOR 1K 1% .125W F TC=0+-100	24546	C4-1/8-T0=1001-F
A6R103	0757-0280	3		RESISTOR 1K 1% .125W F TC=0+-100	24546	C4-1/8-T0=1001-F
A6R104	0698-3444	1	3	RESISTOR 316 1% .125W F TC=0+-100	24546	C4-1/8-T0=316R-F
A6R105	0698-4389	5	1	RESISTOR 64.9 1% .125W F TC=0+-100	24546	C4-1/8-T0=6489-F
A6R106	0698-3445	2	1	RESISTOR 348 1% .125W F TC=0+-100	24546	C4-1/8-T0=348R-F
A6R107	0757-0346	2		RESISTOR 10 1% .125W F TC=0+-100	24546	C4-1/8-T0=10R0-F
A6R108	0757-0984	4	1	RESISTOR 10 1% .5W F TC=0+-100	28480	0757-0984
A6R109	0757-0280	3		RESISTOR 1K 1% .125W F TC=0+-100	24546	C4-1/8-T0=1001-F
A6R110	0757-0280	3		RESISTOR 1K 1% .125W F TC=0+-100	24546	C4-1/8-T0=1001-F
A6R111	0698-3159	5		RESISTOR 26.1K 1% .125W F TC=0+-100	24546	C4-1/8-T0=2612-F
A6R112	0698-3159	5		RESISTOR 26.1K 1% .125W F TC=0+-100	24546	C4-1/8-T0=2612-F
A6R201	0757-0280	3		RESISTOR 1K 1% .125W F TC=0+-100	24546	C4-1/8-T0=1001-F
A6R202	0757-0280	3		RESISTOR 1K 1% .125W F TC=0+-100	24546	C4-1/8-T0=1001-F
A6R203	0757-0280	3		RESISTOR 1K 1% .125W F TC=0+-100	24546	C4-1/8-T0=1001-F
A6R204	0757-0401	0		RESISTOR 100 1% .125W F TC=0+-100	24546	C4-1/8-T0=101-F
A6R205	0757-0280	3		RESISTOR 1K 1% .125W F TC=0+-100	24546	C4-1/8-T0=1001-F
A6R206	0757-0280	3		RESISTOR 1K 1% .125W F TC=0+-100	24546	C4-1/8-T0=1001-F

Table 6-3. Replaceable Parts (cont'd)

Reference Designation	HP Part Number	C D	Qty	Description	Mfr Code	Mfr Part Number
A6R207	0698-4486	3		RESISTOR 24.9K 1% .125W F TC0+-100	24546	C4-1/A-T0-2492-F
A6R20A	0698-4486	3		RESISTOR 24.9K 1% .125W F TC0+-100	24546	C4-1/B-T0-2492-F
A6R301	0698-4471	6	4	RESISTOR 7.15K 1% .125W F TC0+-100	24546	C4-1/A-T0-7151-F
A6R302	2100-3351	6	4	RESISTOR-TRMR 500 10% C SIDE-ADJ 1-TRN	28480	2100-3351
A6R303	0698-4433	0	10	RESISTOR 2.26K 1% .125W F TC0+-100	24546	C4-1/B-T0-2261-F
A6R304	0698-4433	0		RESISTOR 2.26K 1% .125W F TC0+-100	24546	C4-1/B-T0-2261-F
A6R305	0698-4442	1	6	RESISTOR 4.42K 1% .125W F TC0+-100	24546	C4-1/B-T0-4421-F
A6R306	0757-0280	3		RESISTOR 1K 1% .125W F TC0+-100	24546	C4-1/B-T0-1001-F
A6R307	0757-0718	2	4	RESISTOR 200 1% .25W F TC0+-100	24546	C5-1/4-T0-201-F
A6R308	0757-0280	3		RESISTOR 1K 1% .125W F TC0+-100	24546	C4-1/B-T0-1001-F
A6R309	0757-0280	3		RESISTOR 1K 1% .125W F TC0+-100	24546	C4-1/B-T0-1001-F
A6R310	0698-3158	4	5	RESISTOR 23.7K 1% .125W F TC0+-100	24546	C4-1/B-T0-2372-F
A6R311	0698-3158	4		RESISTOR 23.7K 1% .125W F TC0+-100	24546	C4-1/B-T0-2372-F
A6R312	0757-0718	2	4	RESISTOR 200 1% .25W F TC0+-100	24546	C5-1/4-T0-201-F
A6R401	0698-4471	6		RESISTOR 7.15K 1% .125W F TC0+-100	24546	C4-1/B-T0-7151-F
A6R402	2100-3351	6		RESISTOR-TRMR 500 10% C SIDE-ADJ 1-TRN	28480	2100-3351
A6R403	0698-4433	0	0	RESISTOR 2.26K 1% .125W F TC0+-100	24546	C4-1/B-T0-2261-F
A6R404	0698-4433	0	1	RESISTOR 2.26K 1% .125W F TC0+-100	24546	C4-1/B-T0-2261-F
A6R405	0698-4442	1	0	RESISTOR 4.42K 1% .125W F TC0+-100	24546	C4-1/B-T0-4421-F
A6R406	0757-0280	3		RESISTOR 1K 1% .125W F TC0+-100	24546	C4-1/B-T0-1001-F
A6R407	0757-0718	2	0	RESISTOR 200 1% .25W F TC0+-100	24546	C5-1/4-T0-201-F
A6R408	0698-5449	0	5	RESISTOR 5K .1% .125W F TC0+-50	19701	MF4C1/B-T2-5001-B
A6R409	0698-5449	0	0	RESISTOR 5K .1% .125W F TC0+-50	19701	MF4C1/B-T2-5001-B
A6R410	0698-6943	1	1	RESISTOR 20K 1% .125W F TC0+-50	28480	0698-6943
A6R411	0698-3451	0	4	RESISTOR 133K 1% .125W F TC0+-100	24546	C4-1/B-T0-1333-F
A6R412	0698-6608	5	2	RESISTOR 23.5K .1% .125W F TC0+-25	28480	0698-6608
A6R413	0757-0718	2	7	RESISTOR 200 1% .25W F TC0+-100	24546	C5-1/4-T0-201-F
A6R501	0698-3226	7	2	RESISTOR 6.49K 1% .125W F TC0+-100	24546	C4-1/B-T0-6491-F
A6R502	0698-4453	4	4	RESISTOR 402 1% .125W F TC0+-100	24546	C4-1/B-T0-402R-F
A6R503	0698-3226	7		RESISTOR 6.49K 1% .125W F TC0+-100	24546	C4-1/B-T0-6491-F
A6R504	0698-4453	4		RESISTOR 402 1% .125W F TC0+-100	24546	C4-1/B-T0-402R-F
A6R505	0757-0271	2	1	RESISTOR 124K 1% .125W F TC0+-100	24546	C4-1/B-T0-1243-F
A6R506	0757-0444	1		RESISTOR 12.1K 1% .125W F TC0+-100	24546	C4-1/B-T0-1212-F
A6R507	0757-0442	9		RESISTOR 10K 1% .125W F TC0+-100	24546	C4-1/B-T0-1002-F
A6R508	0698-3449	6	1	RESISTOR 28.7K 1% .125W F TC0+-100	24546	C4-1/B-T0-2872-F
A6R509	0698-4521	7	2	RESISTOR 154K 1% .125W F TC0+-100	24546	C4-1/A-T0-1543-F
A6R510	0757-0280	3		RESISTOR 1K 1% .125W F TC0+-100	24546	C4-1/B-T0-1001-F
A6R511	0757-0280	3		RESISTOR 1K 1% .125W F TC0+-100	24546	C4-1/B-T0-1001-F
A6R512	0757-0346	2		RESISTOR 10 1% .125W F TC0+-100	24546	C4-1/B-T0-10R0-F
A6R513	0757-0419	0		RESISTOR 681 1% .125W F TC0+-100	24546	C4-1/B-T0-681R-F
A6R514	0698-00A5	0		RESISTOR 2.61K 1% .125W F TC0+-100	24546	C4-1/B-T0-2611-F
A6R515	0757-0428	8	1	R-FXD 1.62K 1%	0	24546
A6R516	2100-3352	6		R-VAR 1K .5W	28480	2100-3351
A6R517	0698-3259	6	2	RESISTOR 7.87K 1% .125W F TC0+-100	24546	C4-1/B-T0-7871-F
A6R518	0698-4429	4		RESISTOR 1.87K 1% .125W F TC0+-100	24546	C4-1/B-T0-1871-F
A6R519	0757-0280	1	2	RESISTOR 9.09K 1% .125W F TC0+-100	19701	MF4C1/B-T0-9091-F
A6R520	0698-4471	4		R-FXD 7.15K 1%	24546	C4-1/B-T0-6811-F
A6R521	0698-4442	1	7	RESISTOR 4.42K 1% .125W F TC0+-100	24546	C4-1/B-T0-4421-F
A6R522	0757-0458	7		RESISTOR 51.1K 1% .125W F TC0+-100	24546	C4-1/B-T0-5112-F
A6R523	2100-3351	6		RESISTOR-TRMR 500 10% C SIDE-ADJ 1-TRN	28480	2100-3351
A6R601	2100-3350	5	3	RESISTOR-TRMR 200 10% C SIDE-ADJ 1-TRN	28480	2100-3350
A6R602	0757-0422	5	3	RESISTOR 909 1% .125W F TC0+-100	24546	C4-1/B-T0-909R-F
A6R603	0757-0280	3		RESISTOR 1K 1% .125W F TC0+-100	24546	C4-1/B-T0-1001-F
A6R604	0757-0454	3		RESISTOR 33.2K 1% .125W F TC0+-100	24546	C4-1/B-T0-3322-F
A6R605	0757-0458	7		RESISTOR 51.1K 1% .125W F TC0+-100	24546	C4-1/B-T0-5112-F
A6R606	0757-0454	3		RESISTOR 33.2K 1% .125W F TC0+-100	24546	C4-1/B-T0-3322-F
A6R607	0757-0458	9		RESISTOR 51.1K 1% .125W F TC0+-100	24546	C4-1/B-T0-5112-F
A6R609	0757-0442	7		RESISTOR 10K 1% .125W F TC0+-100	24546	C4-1/B-T0-1002-F
A6R610	2100-3356	1	1	RESISTOR-TRMR 200K 10% C SIDE-ADJ 1-TRN	28480	2100-3356
A6R611	0698-4521	7		RESISTOR 154K 1% .125W F TC0+-100	24546	C4-1/B-T0-1543-F
A6R608	0698-3158	4		RESISTOR 23.7K 1% .125W F TC0+-100	24546	C4-1/B-T0-2372-F
A6R612	0698-4444	3		RESISTOR 4.87K 1% .125W F TC0+-100	24546	C4-1/B-T0-4871-F
A6R613	0698-4442	1		RESISTOR 4.42K 1% .125W F TC0+-100	24546	C4-1/B-T0-4421-F
A6R614	2100-3352	7	2	RESISTOR-TRMR 1K 10% C SIDE-ADJ 1-TRN	28480	2100-3352
A6R615	0757-0274	5		RESISTOR 1.21K 1% .125W F TC0+-100	24546	C4-1/B-T0-1213-F
A6R616	0757-0438	3		RESISTOR 5.11K 1% .125W F TC0+-100	24546	C4-1/B-T0-5111-F
A6R617	0698-5449	0		RESISTOR 5K .1% .125W F TC0+-50	19701	MF4C1/B-T2-5001-B
A6R618	0698-5449	0		RESISTOR 5K .1% .125W F TC0+-50	19701	MF4C1/B-T2-5001-B
A6R619	0698-5449	0		RESISTOR 5K .1% .125W F TC0+-50	19701	MF4C1/B-T2-5001-B
A6R801	0698-3152	8		RESISTOR 3.48K 1% .125W F TC0+-100	24546	C4-1/B-T0-3481-F
A6R802	0698-3152	8		RESISTOR 3.48K 1% .125W F TC0+-100	24546	C4-1/B-T0-3481-F
A6R803	0757-1094	9		RESISTOR 1.47K 1% .125W F TC0+-100	24546	C4-1/B-T0-1471-F
A6R804	0698-4425	0		RESISTOR 1.54K 1% .125W F TC0+-100	24546	C4-1/B-T0-1541-F
A6R805	2100-3154	7	4	RESISTOR-TRMR 1K 10% C SIDE-ADJ 1-TRN	02111	43P102
A6R807	0757-0280	3		RESISTOR 1K 1% .125W F TC0+-100	24546	C4-1/B-T0-1001-F

Table 6-3. Replaceable Parts (cont'd)

Reference Designation	HP Part Number	C D	Qty	Description	Mfr Code	Mfr Part Number
A6R80A	069A-4409	0		RESISTOR 127 1X .125W F TC=0+-100	24546	C4-1/8-T0-127R-F
A6R809	069A-3495	2		RESISTOR 866 1X .125W F TC=0+-100	24546	C4-1/8-T0-866R-F
A6R810	2100-3103	6	6	RESISTOR-TRMR 10K 10% C SIDE=ADJ 17-TRN	02111	43P103
A6R811	0698-4470	5	1	RESISTOR 6.98K 1X .125W F TC=0+-100	24546	C4-1/8-T0-6981-F
A6R812	069A-3156	2	6	RESISTOR 14.7K 1X .125W F TC=0+-100	24546	C4-1/8-T0-1472-F
A6R813	0757-0411	2	6	RESISTOR 332 1X .125W F TC=0+-100	24546	C4-1/8-T0-332R-F
A6R814	0757-0280	3		RESISTOR 1K 1X .125W F TC=0+-100	24546	C4-1/8-T0-1001-F
A6R815	0757-0442	9		RESISTOR 10K 1X .125W F TC=0+-100	24546	C4-1/8-T0-1002-F
A6R816	0698-3150	6	1	RESISTOR 2.37K 1X .125W F TC=0+-100	24546	C4-1/8-T0-2371-F
A6R817	069A-445A	9		RESISTOR 590 1X .125W F TC=0+-100	24546	C4-1/8-T0-590R-F
A6R818	069A-4467	0	1	RESISTOR 1.05K 1X .125W F TC=0+-100	24546	C4-1/8-T0-1051-F
A6R819	0698-3446	3	1	RESISTOR 383 1X .125W F TC=0+-100	24546	C4-1/8-T0-383R-F
A6R820	0698-3440	7	1	RESISTOR 196 1X .125W F TC=0+-100	24546	C4-1/8-T0-196R-F
A6R821	0757-0401	0		RESISTOR 100 1X .125W F TC=0+-100	24546	C4-1/8-T0-101-F
A6R822	0698-3150	6		RESISTOR 2.37K 1X .125W F TC=0+-100	24546	C4-1/8-T0-2371-F
A6R823	0757-0424	7		RESISTOR 1.1K 1X .125W F TC=0+-100	24546	C4-1/8-T0-1101-F
A6R824	0757-0438	3		RESISTOR 5.11K 1X .125W F TC=0+-100	24546	C4-1/8-T0-5111-F
A6R825	0757-0283	6		RESISTOR 2K 1X .125W F TC=0+-100	24546	C4-1/8-T0-2001-F
A6R826	2100-3207	1	5	RESISTOR-TRMR 5K 10% C SIDE=ADJ 17-TRN	28480	2100-3207
A6R909	0698-3259	6		RESISTOR 7.87K 1X .125W F TC=0+-100	24546	C4-1/8-T0-7871-F
A6R910	069A-3154	0		RESISTOR 4.22K 1X .125W F TC=0+-100	24546	C4-1/8-T0-4221-F
A6R911	0757-0280	3		RESISTOR 1K 1X .125W F TC=0+-100	24546	C4-1/8-T0-1001-F
A6R912	2100-3056	8	2	RESISTOR-TRMR 5K 10% C SIDE=ADJ 17-TRN	02111	43P502
A6R913	0757-0280	3		RESISTOR 1K 1X .125W F TC=0+-100	24546	C4-1/8-T0-1001-F
A6R914	0757-0280	3		RESISTOR 1K 1X .125W F TC=0+-100	24546	C4-1/8-T0-1001-F
A6R915	2100-3056	8		RESISTOR-TRMR 5K 10% C SIDE=ADJ 17-TRN	02111	43P502
A6R916	0757-0280	3		RESISTOR 1K 1X .125W F TC=0+-100	24546	C4-1/8-T0-1001-F
A6R917	0757-0439	4		RESISTOR 6.81K 1X .125W F TC=0+-100	24546	C4-1/8-T0-6811-F
A6R918	0757-0442	9		RESISTOR 10K 1X .125W F TC=0+-100	24546	C4-1/8-T0-1002-F
A6R919	0757-0442	9		RESISTOR 10K 1X .125W F TC=0+-100	24546	C4-1/8-T0-1002-F
A6R920	2100-3103	6		RESISTOR-TRMR 10K 10% C SIDE=ADJ 17-TRN	02111	43P103
A6R921	0698-0083	8		RESISTOR 1.9AK 1X .125W F TC=0+-100	24546	C4-1/8-T0-1961-F
A6R922	0757-0280	3		RESISTOR 1K 1X .125W F TC=0+-100	24546	C4-1/8-T0-1001-F
A6R923	0757-0439	4		RESISTOR 6.81K 1X .125W F TC=0+-100	24546	C4-1/8-T0-6811-F
A6R924	0757-0442	9		RESISTOR 10K 1X .125W F TC=0+-100	24546	C4-1/8-T0-1002-F
A6R925	0757-0442	9		RESISTOR 10K 1X .125W F TC=0+-100	24546	C4-1/8-T0-1002-F
A6R926	0757-0705	7	1	RESISTOR 47.5 1X .125W F TC=0+-100	28480	0757-0705
A6R927	0757-0346	2		RESISTOR 10 1X .125W F TC=0+-100	24546	C4-1/8-T0-10R0-F
A6U101	1826-0111	7		IC OP AMP GP DUAL T0-99	04713	MC1458G
A6U201	1826-0111	7		IC OP AMP GP DUAL T0-99	04713	MC1458G
A6U301	1826-0043	4		IC OP AMP GP T0-99	0192B	CA3077
A6U302	1826-0059	2		IC OP AMP GP T0-99	01295	LM201AL
A6U401	1826-0043	4		IC OP AMP GP T0-99	0192B	CA3077
A6U402	1826-0059	2		IC OP AMP GP T0-99	01295	LM201AL
A6U501	1826-0043	4		IC OP AMP GP T0-99	0192B	CA3077
A6U502	1826-0180	0	1	IC TIMER TTL MONO/ASTBL	04713	MC1455P1
A6U503	1826-0111	7		IC OP AMP GP DUAL T0-99	04713	MC1458G
A6U601	1826-0188	8	4	IC CONV 8-B-D/A 16-DIP-C	04713	MC1408L-8
A6U602	1826-0161	7	4	IC OP AMP GP QUAD 14-DIP-P	04713	LM324P
A6U701	1820-1745	3	10	IC GATE CMOS NOR QUAD 2-INP	04713	MC14001BCP
A6U702	1820-1963	7	9	IC FF CMOS D-TYPE POS-EDGE-TRIG DUAL	0192B	CD40138AE
A6U703	1820-1956	8	29	IC LCH CMOS COM CLOCK QUAD	0192B	CD4042BE
A6U704	1820-1956	8		IC LCH CMOS COM CLOCK QUAD	0192B	CD4042BE
A6U705	1820-1956	8		IC LCH CMOS COM CLOCK QUAD	0192B	CD4042BE
A6U706	1820-1956	8		IC LCH CMOS COM CLOCK QUAD	0192B	CD4042BE
A6U707	1820-1976	2	6	IC BFR CMOS NON-INV HEX	0192B	CD4050BE
A6U708	1820-1976	2		IC BFR CMOS NON-INV HEX	0192B	CD4050BE
A6U710	1820-1745	3		IC GATE CMOS NOR QUAD 2-INP	04713	MC14001BCP
A6U711	1820-1956	8		IC LCH CMOS COM CLOCK QUAD	0192B	CD4042BE
A6U712	1820-1956	8		IC LCH CMOS COM CLOCK QUAD	0192B	CD4042BE
A6U713	1820-1956	8		IC LCH CMOS COM CLOCK QUAD	0192B	CD4042BE
A6U714	1820-1976	2		IC BFR CMOS NON-INV HEX	0192B	CD4050BE
A6U715	1820-1976	2		IC BFR CMOS NON-INV HEX	0192B	CD4050BE
A6U801	1826-0188	8		IC CONV 8-B-D/A 16-DIP-C	04713	MC1408L-8
A6U802	1826-0161	7		IC OP AMP GP QUAD 14-DIP-P	04713	LM324P
A6U901	1826-0161	7		IC OP AMP GP QUAD 14-DIP-P	04713	LM324P
A6VR501	1902-3171	7	2	DIODE-ZNR 11V 5% DO-7 PDR.4W TC=+.062%	28480	1902-3171
A6VR502	1902-3171	7		DIODE-ZNR 11V 5% DO-7 PDR.4W TC=+.062%	28480	1902-3171
A6VR503	1902-0041	4		DIODE-ZNR 5.11V 5% DO-7 PDR.4W TC=+.009%	28480	1902-0041
A6VR504	1902-0777	3		DIODE-ZNR 1N825 6.2V 5% DO-7 PDR.4W	04713	1N825
A6VR601	1902-0041	4		DIODE-ZNR 5.11V 5% DO-7 PDR.4W TC=+.009%	28480	1902-0041
A6VR602	1902-0786	4		DIODE-ZNR 1N937 9V 5% DO-7 PDR.5W	24046	1N937
A6VR801	1902-0049	2	1	DIODE-ZNR 6.19V 5% DO-7 PDR.4W TC=+.022%	28480	1902-0049
A6VRA02	1902-0786	4		DIODE-ZNR 1N937 9V 5% DO-7 PDR.5W	24046	1N937
A6VRA03	1902-0025	4	9	DIODE-ZNR 10V 5% DO-7 PDR.4W TC=+.06%	28480	1902-0025
A6VRA04	1902-0025	4		DIODE-ZNR 10V 5% DO-7 PDR.4W TC=+.06%	28480	1902-0025

Table 6-3. Replaceable Parts (cont'd)

Reference Designation	HP Part Number	C D	Qty	Description	Mfr Code	Mfr Part Number
A7	08165-06507	0	1	BOARD ASSEMBLY, INPUT MODULATOR	28480	08165-06507
A7C1	0160-2241	5	1	CAPACITOR-FXD 2.2PF +-25PF 500VDC CER	28480	0160-2241
A7C2	0160-0574	3	2	CAPACITOR-FXD .022UF +-20% 100VDC CER	28480	0160-0574
A7C3	0160-0574	3		CAPACITOR-FXD .022UF +-20% 100VDC CER	28480	0160-0574
A7C4	0160-4213	5	3	CAPACITOR-FXD .1UF +-20% 50VDC POLYE	28480	0160-4213
A7C5	0160-0576	5		CAPACITOR-FXD .1UF +-20% 50VDC CER	28480	0160-0576
A7C6	0160-4210	2		CAPACITOR-FXD .022UF +-20% 50VDC POLYE	28480	0160-4210
A7C7	0160-2150	5		CAPACITOR-FXD 33PF +-5% 300VDC MICA	28480	0160-2150
A7C8	0160-3875	3		CAPACITOR-FXD 22PF +-5% 200VDC CER 0+-30	28480	0160-3875
A7C11	0160-2055	9		CAPACITOR-FXD .01UF +-80-20% 100VDC CER	28480	0160-2055
A7C12	0160-4299	7		CAPACITOR-FXD 2200PF +-20% 250VDC CER	56289	C067F251F222M322-CDH
A7C14	0160-4210	2		CAPACITOR-FXD .022UF +-20% 50VDC POLYE	28480	0160-4210
A7C15	0160-0196	3		CAPACITOR-FXD 150PF +-5% 300VDC MICA	72136	DM15F151J0300WV1CP
A7C16	0160-4210	2		CAPACITOR-FXD .022UF +-20% 50VDC POLYE	28480	0160-4210
A7C21	0160-0374	3	4	CAPACITOR-FXD 10UF+-10% 20VDC TA	56289	1500106X902082
A7C22	0160-0374	3		CAPACITOR-FXD 10UF+-10% 20VDC TA	56289	1500106X902082
A7C101	0160-4210	2		CAPACITOR-FXD .022UF +-20% 50VDC POLYE	28480	0160-4210
A7C102	0160-4210	2		CAPACITOR-FXD .022UF +-20% 50VDC POLYE	28480	0160-4210
A7CR1	1901-0050	3		DIODE-SWITCHING 80V 200MA 2NS DO-35	28480	1901-0050
A7CR2	1901-0050	3		DIODE-SWITCHING 80V 200MA 2NS DO-35	28480	1901-0050
A7CR3	1901-0050	3		DIODE-SWITCHING 80V 200MA 2NS DO-35	28480	1901-0050
A7CR4	1901-0050	3		DIODE-SWITCHING 80V 200MA 2NS DO-35	28480	1901-0050
A7CR5	1901-0050	3		DIODE-SWITCHING 80V 200MA 2NS DO-35	28480	1901-0050
A7CP6	1901-0050	3		DIODE-SWITCHING 80V 200MA 2NS DO-35	28480	1901-0050
A7CR7	1901-0050	3		DIODE-SWITCHING 80V 200MA 2NS DO-35	28480	1901-0050
A7CR8	1901-0050	3		DIODE-SWITCHING 80V 200MA 2NS DO-35	28480	1901-0050
A7CR9	1901-0535	9	1	DIODE-SCHOTTKY	28480	1901-0535
A7MP1	4040-0752	9	1	EXTR-PC BD YEL POLY C .062-80-TMKN8	28480	4040-0752
A7Q1	1853-0215	1		TRANSISTOR NPN SI PD=350MW FT=300MHZ	04713	2N3904
A7Q2	1853-0036	2		TRANSISTOR PNP SI PD=310MW FT=250MHZ	28480	1853-0036
A7Q3	1853-0036	2		TRANSISTOR PNP SI PD=310MW FT=250MHZ	28480	1853-0036
A7Q5	1853-0218	2	2	TRANSISTOR PNP SI TO-18 PD=360MW	28480	1853-0218
A7Q6	1853-0036	2		TRANSISTOR PNP SI PD=310MW FT=250MHZ	28480	1853-0036
A7Q8	1853-0218	2		TRANSISTOR PNP SI TO-18 PD=360MW	28480	1853-0218
A7Q101	1853-0215	1		TRANSISTOR NPN SI PD=350MW FT=300MHZ	04713	2N3904
A7R1	0698-4444	3		RESISTOR 4.87K 1% .125W F TC=0+-100	24546	C4=1/8-T0=4871-F
A7R2	0698-3153	9	1	RESISTOR 3.83K 1% .125W F TC=0+-100	24546	C4=1/8-T0=3831-F
A7R3	0757-0317	7	1	RESISTOR 1.33K 1% .125W F TC=0+-100	24546	C4=1/8-T0=1331-F
A7R4	2100-3274	2	1	RESISTOR-TRMR 10K 10% C SIDE-ADJ 1-TRN	28480	2100-3274
A7R5	0757-0442	9		RESISTOR 10K 1% .125W F TC=0+-100	24546	C4=1/8-T0=1002-F
A7R6	0757-0407	6		RESISTOR 200 1% .125W F TC=0+-100	24546	C4=1/8-T0=201-F
A7R7	0698-4453	4		RESISTOR 402 1% .125W F TC=0+-100	24546	C4=1/8-T0=402R-F
A7R8	0698-4453	4		RESISTOR 402 1% .125W F TC=0+-100	24546	C4=1/8-T0=402R-F
A7R9	0757-0280	3		RESISTOR 1K 1% .125W F TC=0+-100	24546	C4=1/8-T0=1001-F
A7R10	0757-0280	3		RESISTOR 1K 1% .125W F TC=0+-100	24546	C4=1/8-T0=1001-F
A7R11	0757-0280	3		RESISTOR 1K 1% .125W F TC=0+-100	24546	C4=1/8-T0=1001-F
A7R12	0757-0458	7		RESISTOR 51.1K 1% .125W F TC=0+-100	24546	C4=1/8-T0=5112-F
A7R13	0757-0349	5		RESISTOR 22.6K 1% .125W F TC=0+-100	24546	C4=1/8-T0=2262-F
A7R14	0757-0465	6		RESISTOR 100K 1% .125W F TC=0+-100	24546	C4=1/8-T0=1003-F
A7R15	0757-0280	3		RESISTOR 1K 1% .125W F TC=0+-100	24546	C4=1/8-T0=1001-F
A7R16	0698-4435	2		RESISTOR 2.49K 1% .125W F TC=0+-100	24546	C4=1/8-T0=2491-F
A7R17	0757-0394	0		RESISTOR 51.1K 1% .125W F TC=0+-100	24546	C4=1/8-T0=5112-F
A7R18	0757-0283	6		RESISTOR 2K 1% .125W F TC=0+-100	24546	C4=1/8-T0=2001-F
A7R19	0757-0411	2		RESISTOR 332 1% .125W F TC=0+-100	24546	C4=1/8-T0=332R-F
A7R20	0757-0280	3		RESISTOR 1K 1% .125W F TC=0+-100	24546	C4=1/8-T0=1001-F
A7R21	0757-0283	6		RESISTOR 2K 1% .125W F TC=0+-100	24546	C4=1/8-T0=2001-F
A7R22	0757-0411	2		RESISTOR 332 1% .125W F TC=0+-100	24546	C4=1/8-T0=332R-F
A7R23	0757-0418	9		RESISTOR 619 1% .125W F TC=0+-100	24546	C4=1/8-T0=619R-F
A7R24	0757-0433	8		RESISTOR 3.32K 1% .125W F TC=0+-100	24546	C4=1/8-T0=3321-F
A7R25	0757-0419	0		RESISTOR 681 1% .125W F TC=0+-100	24546	C4=1/8-T0=681R-F
A7R26	0698-3155	1		RESISTOR 4.64K 1% .125W F TC=0+-100	24546	C4=1/8-T0=4641-F
A7R27	0757-0419	0		RESISTOR 681 1% .125W F TC=0+-100	24546	C4=1/8-T0=681R-F
A7R28	0757-0419	0		RESISTOR 681 1% .125W F TC=0+-100	24546	C4=1/8-T0=681R-F
A7R29	0757-0280	3		RESISTOR 1K 1% .125W F TC=0+-100	24546	C4=1/8-T0=1001-F
A7R30	0757-0419	0		RESISTOR 681 1% .125W F TC=0+-100	24546	C4=1/8-T0=681R-F
A7R31	0698-3433	8	1	RESISTOR 28.7 1% .125W F TC=0+-100	03888	PME55-1/8-T0=28R7-F
A7R32	0698-3488	3		RESISTOR 442 1% .125W F TC=0+-100	24546	C4=1/8-T0=442R-F
A7R33	0757-0401	0		RESISTOR 100 1% .125W F TC=0+-100	24546	C4=1/8-T0=101-F
A7R35	0757-0390	6	1	RESISTOR 36.5 1% .125W F TC=0+-100	24546	C4=1/8-T0=36R5-F
A7R36	0757-0419	0		RESISTOR 681 1% .125W F TC=0+-100	24546	C4=1/8-T0=681R-F
A7R37	0757-0280	3		RESISTOR 1K 1% .125W F TC=0+-100	24546	C4=1/8-T0=1001-F
A7R38	0757-0280	3		RESISTOR 1K 1% .125W F TC=0+-100	24546	C4=1/8-T0=1001-F
A7R39	0698-3488	3		RESISTOR 442 1% .125W F TC=0+-100	24546	C4=1/8-T0=442R-F
A7R40	0757-0280	3		RESISTOR 1K 1% .125W F TC=0+-100	24546	C4=1/8-T0=1001-F
A7R43	0698-3488	3		RESISTOR 442 1% .125W F TC=0+-100	24546	C4=1/8-T0=442R-F

Table 6-3. Replaceable Parts (cont'd)

Reference Designation	HP Part Number	C D	Qty	Description	Mfr Code	Mfr Part Number
A7R44	0698-4392	0	1	RESISTOR 71.5 1% .125W F TC=0+-100	24546	C4-1/8-T0-71R5-F
A7R45	0698-4469	2	1	RESISTOR 1.15K 1% .125W F TC=0+-100	24546	C4-1/8-T0-1151-F
A7R46	0698-4420	5	2	RESISTOR 226 1% .125W F TC=0+-100	24546	C4-1/8-T0-226R-F
A7R50	0698-3488	3		RESISTOR 442 1% .125W F TC=0+-100	24546	C4-1/8-T0-422R-F
A7R51	0698-3155	1		RESISTOR 4.64K 1% .125W F TC=0+-100	24546	C4-1/8-T0-4641-F
A7R52	0698-3155	1		RESISTOR 4.64K 1% .125W F TC=0+-100	24546	C4-1/8-T0-4641-F
A7R53	0698-3155	1		RESISTOR 4.64K 1% .125W F TC=0+-100	24546	C4-1/8-T0-4641-F
A7R54	0698-3155	1		RESISTOR 4.64K 1% .125W F TC=0+-100	24546	C4-1/8-T0-4641-F
A7R55	0757-0419	0		RESISTOR 681 1% .125W F TC=0+-100	24546	C4-1/8-T0-681R-F
A7R56	0757-0400	9	1	RESISTOR 90.9 1% .125W F TC=0+-100	24546	C4-1/8-T0-90R9-F
A7R57	0698-3150	6		RESISTOR 2.37K 1% .125W F TC=0+-100	24546	C4-1/8-T0-2371-F
A7R58	0698-3443	0		RESISTOR 287 1% .125W F TC=0+-100	24546	C4-1/8-T0-287R-F
A7R59	0757-0419	0		RESISTOR 681 1% .125W F TC=0+-100	24546	C4-1/8-T0-681R-F
A7R60	0757-0280	3		RESISTOR 1K 1% .125W F TC=0+-100	24546	C4-1/8-T0-1001-F
A7R61	0757-0409	8	1	RESISTOR 274 1% .125W F TC=0+-100	24546	C4-1/8-T0-274R-F
A7R62	0698-4452	3	1	RESISTOR 374 1% .125W F TC=0+-100	24546	C4-1/8-T0-374R-F
A7R63	0698-3488	3		RESISTOR 442 1% .125W F TC=0+-100	24546	C4-1/8-T0-422R-F
A7R101	0757-0349	5		RESISTOR 22.6K 1% .125W F TC=0+-100	24546	C4-1/8-T0-2262-F
A7R102	0757-0349	5		RESISTOR 22.6K 1% .125W F TC=0+-100	24546	C4-1/8-T0-2262-F
A7U1	1820-0810	1	1	IC RCVR ECL LINE RCVR TPL 2-INP	04713	MC10116P
A7U2	1820-1400	7	2	IC GATE ECL AND QUAD 2-INP	04713	MC10104P
A7U3	1820-0802	1		IC GATE ECL NOR QUAD 2-INP	04713	MC10102P
A7U4	1820-0817	8	1	IC FF ECL D-M/S DUAL	04713	MC10131P
A7U5	1820-0802	1		IC GATE ECL NOR QUAD 2-INP	04713	MC10102P
A7U6	1820-1400	7		IC GATE ECL AND QUAD 2-INP	04713	MC10104P
A7U7	1820-0804	3	1	IC GATE ECL NOR TPL	04713	MC10106P
A7U8	1820-0802	1		IC GATE ECL NOR QUAD 2-INP	04713	MC10102P
A7U9	1820-0820	3	1	IC FF ECL J-BAR K-BAR COM CLOCK DUAL	04713	MC10135L
A7U10	1820-1193	5	3	IC CNTR TTL LS BIN ASYNCHRO	01295	SN74LS197N
A7U11	1820-1193	5		IC CNTR TTL LS BIN ASYNCHRO	01295	SN74LS197N
A7U12	1820-1193	5		IC CNTR TTL LS BIN ASYNCHRO	01295	SN74LS197N
A7U13	1820-1130	0	1	IC GATE TTL 3 NAND 13-INP	01295	SN74S133N
A7U14	1820-1746	4		IC BFR CMOS INV HEX	04713	MC14049UBCP
A7U101	1820-1745	3		IC GATE CMOS NOR QUAD 2-INP	04713	MC14001BCP
A7U102	1820-1963	7		IC FF CMOS D-TYPE POS-EDGE-TRIG DUAL	0192B	CD40138AE
A7U103	1820-1745	3		IC GATE CMOS NOR QUAD 2-INP	04713	MC14001BCP
A7U104	1820-1956	8		IC LCH CMOS COM CLOCK QUAD	0192B	CD4042BE
A7U105	1820-1956	8		IC LCH CMOS COM CLOCK QUAD	0192B	CD4042BE
A7U106	1820-1956	8		IC LCH CMOS COM CLOCK QUAD	0192B	CD4042BE
A7U107	1820-1956	8		IC LCH CMOS COM CLOCK QUAD	0192B	CD4042BE
A7U108	1820-1956	8		IC LCH CMOS COM CLOCK QUAD	0192B	CD4042BE
A8	08165-66508	1	1	BOARD ASSEMBLY, VCO CONTROL	28480	08165-66508
A8C101	0160-3048	2	6	CAPACITOR-FXD 8000PF +-1% 100VDC MICA	28480	0160-3048
A8C102	0160-3048	2		CAPACITOR-FXD 8000PF +-1% 100VDC MICA	28480	0160-3048
A8C103	0160-3048	2		CAPACITOR-FXD 8000PF +-1% 100VDC MICA	28480	0160-3048
A8C104	0160-3048	2		CAPACITOR-FXD 8000PF +-1% 100VDC MICA	28480	0160-3048
A8C105	0160-3048	2		CAPACITOR-FXD 8000PF +-1% 100VDC MICA	28480	0160-3048
A8C106	0160-3048	2		CAPACITOR-FXD 8000PF +-1% 100VDC MICA	28480	0160-3048
A8C107	0160-4209	9		CAPACITOR-FXD .01UF +-20% 50VDC POLYE	28480	0160-4209
A8C108	0160-0174	9		CAPACITOR-FXD .47UF +80-20% 25VDC CER	28480	0160-0174
A8C109	0160-4209	9		CAPACITOR-FXD .01UF +-20% 50VDC POLYE	28480	0160-4209
A8C110	0160-1704	5		CAPACITOR-FXD .47UF+-10% 6VDC TA	56289	150D476X900682
A8C111	0160-0375	4		CAPACITOR-FXD 68UF+-10% 20VDC TA	56289	150D686X902082
A8C112	0160-0375	4		CAPACITOR-FXD 68UF+-10% 20VDC TA	56289	150D686X902082
A8C113	0160-1704	5		CAPACITOR-FXD 47UF+-10% 6VDC TA	56289	150D476X900682
A8C201	0160-0128	3		CAPACITOR-FXD 2.2UF +-20% 50VDC CER	28480	0160-0128
A8C202	0160-4211	3	1	CAPACITOR-FXD .047UF +-20% 50VDC POLYE	28480	0160-4211
A8C203	0160-4213	5		CAPACITOR-FXD .1UF +-20% 50VDC POLYE	28480	0160-4213
A8C301	0140-0193	0	4	CAPACITOR-FXD 82PF +-5% 300VDC MICA	72136	DM15E620J03004V1CR
A8C302	0160-0174	9		CAPACITOR-FXD .47UF +80-20% 25VDC CER	28480	0160-0174
A8C402	0160-2150	5		CAPACITOR-FXD 33PF +-5% 300VDC MICA	28480	0160-2150
A8C501	0140-0196	3		CAPACITOR-FXD 150PF +-5% 300VDC MICA	72136	DM15F151J03004V1CR
A8C502	0140-0196	3		CAPACITOR-FXD 150PF +-5% 300VDC MICA	72136	DM15F151J03004V1CR
A8CR201	1901-0040	1		DIODE-SWITCHING 30V 50MA 2NS DO-35	28480	1901-0040
A8CR202	1901-0040	1		DIODE-SWITCHING 30V 50MA 2NS DO-35	28480	1901-0040
A8CR301	1901-0044	5		DIODE-SWITCHING 50V 50MA 6NS	28480	1901-0044
A8CR302	1901-0044	5		DIODE-SWITCHING 50V 50MA 6NS	28480	1901-0044
A8CR303	1901-0044	5		DIODE-SWITCHING 50V 50MA 6NS	28480	1901-0044
A8CR304	1901-0044	5		DIODE-SWITCHING 50V 50MA 6NS	28480	1901-0044
A8CR401	1901-0040	1		DIODE-SWITCHING 30V 50MA 2NS DO-35	28480	1901-0040
A8CR402	1901-0040	1		DIODE-SWITCHING 30V 50MA 2NS DO-35	28480	1901-0040
A8CR403	1901-0044	5		DIODE-SWITCHING 50V 50MA 6NS	28480	1901-0044
A8CR404	1901-0044	5		DIODE-SWITCHING 50V 50MA 6NS	28480	1901-0044

Table 6-3. Replaceable Parts (cont'd)

Reference Designation	HP Part Number	C D	Qty	Description	Mfr Code	Mfr Part Number
ARCR405	1901-0044	5		DIODE-SWITCHING 50V 50MA 6NS	28480	1901-0044
ARCR406	1901-0044	5		DIODE-SWITCHING 50V 50MA 6NS	28480	1901-0044
ARCR501	1901-0040	1		DIODE-SWITCHING 30V 50MA 2NS DO-35	28480	1901-0040
ARCR502	1901-0040	1		DIODE-SWITCHING 30V 50MA 2NS DO-35	28480	1901-0040
AR401	0490-1079	4		RELAY-REED 1A 500MA 100VDC 5VDC-COIL	28480	0490-1079
AR402	0490-1079	4		RELAY-REED 1A 500MA 100VDC 5VDC-COIL	28480	0490-1079
ABMP1	0A165-00601	7	1	SHIELD	28480	0A165-00601
ABMP2	4040-0751	1	1	EXTR-PC 80 ORN POLYCO .062-80-TMKNS	28480	4040-0751
ARQ101	1A54-0215	1		TRANSISTOR NPN SI PD=350MW FT=300MHZ	04713	2N3904
ARQ102	1A54-0215	1		TRANSISTOR NPN SI PD=350MW FT=300MHZ	04713	2N3904
ARQ201	1A53-0036	2		TRANSISTOR PNP SI PD=310MW FT=250MHZ	28480	1A53-0036
ARQ202	1A53-0036	2		TRANSISTOR PNP SI PD=310MW FT=250MHZ	28480	1A53-0036
ARQ203	1A54-0215	1		TRANSISTOR NPN SI PD=350MW FT=300MHZ	04713	2N3904
ARQ301	1A55-0081	1		TRANSISTOR J-FET N-CHAN D-MODE SI	01295	2N5245
ARQ302	1A55-0081	1		TRANSISTOR J-FET N-CHAN D-MODE SI	01295	2N5245
ARQ303	1A55-0081	1		TRANSISTOR J-FET N-CHAN D-MODE SI	01295	2N5245
ARQ304	1A53-0036	2		TRANSISTOR PNP SI PD=310MW FT=250MHZ	28480	1A53-0036
ARQ305	1A53-0036	2		TRANSISTOR PNP SI PD=310MW FT=250MHZ	28480	1A53-0036
ARQ401	1A54-0215	1		TRANSISTOR NPN SI PD=350MW FT=300MHZ	04713	2N3904
ARQ402	1A54-0215	1		TRANSISTOR NPN SI PD=350MW FT=300MHZ	04713	2N3904
ARQ403	1A53-0086	2		TRANSISTOR PNP SI PD=310MW FT=40MHZ	27014	2N5087
ARQ404	1A54-0215	1		TRANSISTOR NPN SI PD=350MW FT=300MHZ	04713	2N3904
ARQ405	1A53-0086	2		TRANSISTOR PNP SI PD=310MW FT=40MHZ	27014	2N5087
ARQ406	1A54-0215	1		TRANSISTOR NPN SI PD=350MW FT=300MHZ	04713	2N3904
ARQ407	1A54-0215	1		TRANSISTOR NPN SI PD=350MW FT=300MHZ	04713	2N3904
ARQ408	1A55-0386	9	1	TRANSISTOR J-FET 2N4392 N-CHAN D-MODE	04713	2N4392
ARQ409	1A54-0392	5		TRANSISTOR NPN SI PD=310MW FT=50MHZ	04713	2N5088
ARQ410	1A54-0392	5		TRANSISTOR NPN SI PD=310MW FT=50MHZ	04713	2N5088
ARQ411	1A54-0583	6		TRANSISTOR NPN SI TO-92 PD=310MW	04713	MP8-A18
ARQ412	1A54-0583	6		TRANSISTOR NPN SI TO-92 PD=310MW	04713	MP8-A18
ARQ413	1A54-0215	1		TRANSISTOR NPN SI PD=350MW FT=300MHZ	04713	2N3904
ARQ501	1A54-0215	1		TRANSISTOR NPN SI PD=350MW FT=300MHZ	04713	2N3904
ARQ502	1A53-0036	2		TRANSISTOR PNP SI PD=310MW FT=250MHZ	28480	1A53-0036
ARR101	0698-3158	4		RESISTOR 23.7K 1% .125W F TC0+/-100	24546	C4-1/8-T0-2372-F
ARR102	0698-3158	4		RESISTOR 23.7K 1% .125W F TC0+/-100	24546	C4-1/8-T0-2372-F
ARR103	0698-4482	9	1	RESISTOR 17.4K 1% .125W F TC0+/-100	03888	PME55-1/8-T0-1742-F
ARR104	0757-0444	1		RESISTOR 12.1K 1% .125W F TC0+/-100	24546	C4-1/8-T0-1212-F
ARR105	0698-3450	9		RESISTOR 42.2K 1% .125W F TC0+/-100	24546	C4-1/8-T0-4222-F
ARR106	0698-3450	9		RESISTOR 42.2K 1% .125W F TC0+/-100	24546	C4-1/8-T0-4222-F
ARR107	0698-3450	8	2	RESISTOR 15.4K 1% .125W F TC0+/-100	24546	C4-1/8-T0-1542-F
ARR108	0757-0444	1		RESISTOR 12.1K 1% .125W F TC0+/-100	24546	C4-1/8-T0-1212-F
ARR109	0757-0199	3		RESISTOR 21.5K 1% .125W F TC0+/-100	24546	C4-1/8-T0-2152-F
ARR110	0757-0199	3		RESISTOR 21.5K 1% .125W F TC0+/-100	24546	C4-1/8-T0-2152-F
ARR111	0757-0199	3		RESISTOR 21.5K 1% .125W F TC0+/-100	24546	C4-1/8-T0-2152-F
ARR112	0757-0444	1		RESISTOR 12.1K 1% .125W F TC0+/-100	24546	C4-1/8-T0-1212-F
ARR113	0757-0288	1		RESISTOR 9.09K 1% .125W F TC0+/-100	19701	MF4C1/8-T0-9091-F
ARR115	0757-0200	7		RESISTOR 5.62K 1% .125W F TC0+/-100	24546	C4-1/8-T0-5621-F
ARR116	0757-1094	9		RESISTOR 1.47K 1% .125W F TC0+/-100	24546	C4-1/8-T0-1471-F
ARR117	0757-0346	2		RESISTOR 10.1K 1% .125W F TC0+/-100	24546	C4-1/8-T0-1010-F
ARR119	0698-3441	8	1	RESISTOR 215 1% .125W F TC0+/-100	24546	C4-1/8-T0-215R-F
ARR120	0757-0441	8	2	RESISTOR 8.25K 1% .125W F TC0+/-100	24546	C4-1/8-T0-8251-F
ARR121	0757-0417	8		RESISTOR 562 1% .125W F TC0+/-100	24546	C4-1/8-T0-562R-F
ARR201	0757-0442	9		RESISTOR 10K 1% .125W F TC0+/-100	24546	C4-1/8-T0-1002-F
ARR202	0698-3155	1		RESISTOR 4.64K 1% .125W F TC0+/-100	24546	C4-1/8-T0-4641-F
ARR203	0757-0452	1	3	RESISTOR 27.4K 1% .125W F TC0+/-100	24546	C4-1/8-T0-2742-F
ARR204	0698-3245	0	3	RESISTOR 20.5K 1% .125W F TC0+/-100	24546	C4-1/8-T0-2052-F
ARR205	0757-0459	8	2	RESISTOR 56.2K 1% .125W F TC0+/-100	24546	C4-1/8-T0-5622-F
ARR206	0757-0439	4		RESISTOR 6.81K 1% .125W F TC0+/-100	24546	C4-1/8-T0-6811-F
ARR207	0757-0439	4		RESISTOR 6.81K 1% .125W F TC0+/-100	24546	C4-1/8-T0-6811-F
ARR208	0757-0444	1		RESISTOR 12.1K 1% .125W F TC0+/-100	24546	C4-1/8-T0-1212-F
ARR209	0757-0442	9		RESISTOR 10K 1% .125W F TC0+/-100	24546	C4-1/8-T0-1002-F
ARR210	0698-3155	8		RESISTOR 4.64K 1% .125W F TC0+/-100	24546	C4-1/8-T0-4641-F
ARR211	0698-0082	7	6	RESISTOR 464 1% .125W F TC0+/-100	24546	C4-1/8-T0-4640-F
ARR212	0757-0452	1		RESISTOR 27.4K 1% .125W F TC0+/-100	24546	C4-1/8-T0-2742-F
ARR301	0757-1094	9		RESISTOR 1.47K 1% .125W F TC0+/-100	24546	C4-1/8-T0-1471-F
ARR302	0698-4480	0	1	R-FXD 15.8K 1%	24546	C4-1/8-T0-1872-F
ARR303	0698-3359	7	1	R-FXD 12.7K 1%	24546	C4-1/8-T0-1152-F
ARR304	0698-3558	8		RESISTOR 4.02K 1% .125W F TC0+/-100	24546	C4-1/8-T0-4021-F
ARR305	0698-6320	8	4	RESISTOR 5K 1% .125W F TC0+/-25	03888	PME55-1/8-T0-5001-B
ARR306	0757-0280	3		RESISTOR 1K 1% .125W F TC0+/-100	24546	C4-1/8-T0-1001-F
ARR307	0698-6320	8		RESISTOR 5K 1% .125W F TC0+/-25	03888	PME55-1/8-T0-5001-b
ARR308	0757-0439	4		RESISTOR 6.81K 1% .125W F TC0+/-100	24546	C4-1/8-T0-6811-F
ARR309	0698-3136	8		RESISTOR 17.8K 1% .125W F TC0+/-100	24546	C4-1/8-T0-1782-F

Table 6-3. Replaceable Parts (cont'd)

Reference Designation	HP Part Number	C D	Qty	Description	Mfr Code	Mfr Part Number
ARR310	0757-0439	4		RESISTOR 6.81K 1% .125W F TC0+/-100	24546	C4-1/8-T0-6811-F
ARR311	0698-3136	8		RESISTOR 17.8K 1% .125W F TC0+/-100	24546	C4-1/8-T0-1782-F
ARR312	0757-0422	5		RESISTOR 909 1% .125W F TC0+/-100	24546	C4-1/8-T0-909H-F
ARR313	2100-3350	5		RESISTOR-TRMR 200 10% C SIDE=ADJ 1-TRN	28480	2100-3350
ARR314	0698-6320	8		RESISTOR 5K .1% .125W F TC0+/-25	0388A	PME55-1/8-T9-5001-H
ARR315	0698-6320	8		RESISTOR 5K .1% .125W F TC0+/-25	0388A	PME55-1/8-T9-5001-H
ARR317	0757-0280	3		RESISTOR 1K 1% .125W F TC0+/-100	24546	C4-1/8-T0-1001-F
ARR318	2100-3350	5		RESISTOR-TRMR 200 10% C SIDE=ADJ 1-TRN	28480	2100-3350
ARR319	0698-6348	0		RESISTOR 3K .1% .125W F TC0+/-25	28480	0698-6348
ARR320	0698-6348	0	2	RESISTOR 3K .1% .125W F TC0+/-25	28480	0698-6348
ARR401	0757-0439	4		RESISTOR 6.81K 1% .125W F TC0+/-100	24546	C4-1/8-T0-6811-F
ARR402	0757-0439	4		RESISTOR 6.81K 1% .125W F TC0+/-100	24546	C4-1/8-T0-6811-F
ARR403	0698-3245	0		RESISTOR 20.5K 1% .125W F TC0+/-100	24546	C4-1/8-T0-2052-F
ARR404	0698-3156	2		RESISTOR 14.7K 1% .125W F TC0+/-100	24546	C4-1/8-T0-1472-F
ARR405	2100-3207	1		RESISTOR-TRMR 5K 10% C SIDE=ADJ 1-TRN	28480	2100-3207
ARR406	0757-0458	7		RESISTOR 51.1K 1% .125W F TC0+/-100	24546	C4-1/8-T0-5112-F
ARR407	2100-3354	9	2	RESISTOR-TRMR 50K 10% C SIDE=ADJ 1-TRN	28480	2100-3354
ARR408	0698-3245	0		RESISTOR 20.5K 1% .125W F TC0+/-100	24546	C4-1/8-T0-2052-F
ARR409	2100-3352	7		RESISTOR-TRMR 1K 10% C SIDE=ADJ 1-TRN	28480	2100-3352
ARR410	0698-4444	3		RESISTOR 4.87K 1% .125W F TC0+/-100	24546	C4-1/8-T0-4871-F
ARR411	0757-0459	8		RESISTOR 56.2K 1% .125W F TC0+/-100	24546	C4-1/8-T0-5622-F
ARR412	2100-3355	0	1	RESISTOR-TRMR 100K 10% C SIDE=ADJ 1-TRN	28480	2100-3355
ARR413	0757-0199	3		RESISTOR 21.5K 1% .125W F TC0+/-100	24546	C4-1/8-T0-2152-F
ARR414	0698-3178	8		RESISTOR 487 1% .125W F TC0+/-100	24546	C4-1/8-T0-487R-F
ARR415	0757-0444	1		RESISTOR 12.1K 1% .125W F TC0+/-100	24546	C4-1/8-T0-1212-F
ARR416	0757-0444	1		RESISTOR 12.1K 1% .125W F TC0+/-100	24546	C4-1/8-T0-1212-F
ARR417	0757-0417	8		RESISTOR 562 1% .125W F TC0+/-100	24546	C4-1/8-T0-562R-F
ARR418	2100-3207	1		RESISTOR-TRMR 5K 10% C SIDE=ADJ 1-TRN	28480	2100-3207
ARR419	0757-1094	9		RESISTOR 1.47K 1% .125W F TC0+/-100	24546	C4-1/8-T0-1471-F
ARR420	2100-3207	1		RESISTOR-TRMR 5K 10% C SIDE=ADJ 1-TRN	28480	2100-3207
ARR421	0757-0433	8		RESISTOR 3.32K 1% .125W F TC0+/-100	24546	C4-1/8-T0-3321-F
ARR422	0757-0439	4		RESISTOR 6.81K 1% .125W F TC0+/-100	24546	C4-1/8-T0-6811-F
ARR423	0698-3156	2		RESISTOR 14.7K 1% .125W F TC0+/-100	24546	C4-1/8-T0-1472-F
ARR424	0757-0290	5		RESISTOR 6.19K 1% .125W F TC0+/-100	19701	MF4C1/8-T0-6191-F
ARR425	0698-3156	2		RESISTOR 14.7K 1% .125W F TC0+/-100	24546	C4-1/8-T0-1472-F
ARR426	0757-0290	5		RESISTOR 6.19K 1% .125W F TC0+/-100	19701	MF4C1/8-T0-6191-F
ARR427	0698-0083	8		RESISTOR 1.96K 1% .125W F TC0+/-100	24546	C4-1/8-T0-1961-F
ARR428	0698-4442	1		RESISTOR 4.42K 1% .125W F TC0+/-100	24546	C4-1/8-T0-4421-F
ARR429	2100-3358	3	3	RESISTOR-TRMR 1M 20% C SIDE=ADJ 1-TRN	28480	2100-3358
ARR430	0698-5094	1		RESISTOR 5.1M 5% .25W FC TC=900/+1100	01121	CB5155
ARR431	0757-0467	8	3	RESISTOR 121K 1% .125W F TC0+/-100	24546	C4-1/8-T0-1213-F
ARR432	0757-0454	3		RESISTOR 33.2K 1% .125W F TC0+/-100	24546	C4-1/8-T0-3322-F
ARR433	0683-6855	3	1	RESISTOR 6.8M 5% .25W FC TC=900/+1100	01121	CB6855
ARR434	0757-0467	8		RESISTOR 121K 1% .125W F TC0+/-100	24546	C4-1/8-T0-1213-F
ARR435	0757-0454	3		RESISTOR 33.2K 1% .125W F TC0+/-100	24546	C4-1/8-T0-3322-F
ARR436	0683-1065	7		RESISTOR 10M 5% .25W FC TC=900/+1100	01121	CB1065
ARR437	0757-0444	1		RESISTOR 12.1K 1% .125W F TC0+/-100	24546	C4-1/8-T0-1212-F
ARR438	0757-0439	4		RESISTOR 6.81K 1% .125W F TC0+/-100	24546	C4-1/8-T0-6811-F
ARR439	0757-0444	1		RESISTOR 12.1K 1% .125W F TC0+/-100	24546	C4-1/8-T0-1212-F
ARR440	0757-0444	1		RESISTOR 12.1K 1% .125W F TC0+/-100	24546	C4-1/8-T0-1212-F
ARR501	0757-0442	9		RESISTOR 10K 1% .125W F TC0+/-100	24546	C4-1/8-T0-1002-F
ARR502	0757-0442	9		RESISTOR 10K 1% .125W F TC0+/-100	24546	C4-1/8-T0-1002-F
ARR503	0757-0439	4		RESISTOR 6.81K 1% .125W F TC0+/-100	24546	C4-1/8-T0-6811-F
ARR504	0757-0439	4		RESISTOR 6.81K 1% .125W F TC0+/-100	24546	C4-1/8-T0-6811-F
ARR505	0757-0444	1		RESISTOR 12.1K 1% .125W F TC0+/-100	24546	C4-1/8-T0-1212-F
ARR506	0757-0452	1		RESISTOR 27.4K 1% .125W F TC0+/-100	24546	C4-1/8-T0-2742-F
ARR507	0757-0274	5		RESISTOR 1.21K 1% .125W F TC0+/-100	24546	C4-1/8-T0-1213-F
ARU101	1826-0315	3		IC OP AMP GP QUAD 14-DIP-P	27014	LM348N
ARU201	1820-1188	8	2	IC PL LOOP 16-DIP-P	01928	CD4046AF
ARU202	1826-0043	4		IC OP AMP GP TO-99	01928	CA307T
ARU301	1826-0043	4		IC OP AMP GP TO-99	01928	CA307T
ARU302	1826-01A8	8		IC CONV 8-B-D/A 16-DIP-C	04713	MC1408L-8
ARU303	1826-0161	7		IC OP AMP GP QUAD 14-DIP-P	04713	LM324P
ARU401	1826-0059	2		IC OP AMP GP TO-99	01295	LM201AL
ARU402	1826-0415	4	1	IC SWITCH ANLG QUAD 16-DIP-P	18324	SD5000B
ARU501	1826-0111	7		IC OP AMP GP DUAL TO-99	04713	MC1458G
ARU601	1820-1956	8		IC LCH CMOS COM CLOCK QUAD	01928	CD4042BL
ARU602	1820-1956	8		IC LCH CMOS COM CLOCK QUAD	01928	CD4042BE
ARU603	1820-1956	8		IC LCH CMOS COM CLOCK QUAD	01928	CD4042BE
ARU604	1820-1976	2		IC BFR CMOS NON-INV HEX	01928	CD4050BE
ARU605	1820-1976	2		IC BFR CMOS NON-INV HEX	01928	CD4050BE
ARU606	1820-1956	8		IC LCH CMOS COM CLOCK QUAD	01928	CD4042BE
ARU701	1820-1745	3		IC GATE CMOS NOR QUAD 2-INV	04713	MC14001BCP
ARU702	1820-1963	7		IC FF CMOS D-TYPE POS-EDGE-TRIG DUAL	01928	CD4013BAE
ARU703	1820-1745	3		IC GATE CMOS NOR QUAD 2-INV	04713	MC14001BCP
ARU704	1820-1956	8		IC LCH CMOS COM CLOCK QUAD	01928	CD4042BE
ARU705	1820-1956	8		IC LCH CMOS COM CLOCK QUAD	01928	CD4042BE

Table 6-3. Replaceable Parts (cont'd)

Reference Designation	HP Part Number	C D	Qty	Description	Mfr Code	Mfr Part Number
AAU707	1820-1956	A		IC LCM CMOS COM CLOCK QUAD	0192B	CD04028E
AAU708	1820-1956	B		IC LCM CMOS COM CLOCK QUAD	0192B	CD04028E
AAU709	1820-1956	A		IC LCM CMOS COM CLOCK QUAD	0192B	CD04028E
ABVR201	1902-0025	4		DIODE-ZNR 10V 5% DO-7 PD=.4W TC=+.06X	28480	1902-0025
ABVR202	1902-0025	4		DIODE-ZNR 10V 5% DO-7 PD=.4W TC=+.06X	28480	1902-0025
ABVR301	1902-0041	7	1	DIODE-ZNR 5.11V 5%	28480	1902-3105
ABVR302	1902-0041	4		DIODE-ZNR 5.11V 5% DO-7 PD=.4W TC=+.009X	28480	1902-0041
ABVR303	1902-0041	4		DIODE-ZNR 5.11V 5% DO-7 PD=.4W TC=+.009X	28480	1902-0041
A9	08165-66509	2	1	BOARD ASSEMBLY, REFERENCE LOOP	28480	08165-66509
A9C201	0160-4209	9		CAPACITOR-FXD .01UF +-20% 50VDC POLYE	28480	0160-4209
A9C202	0160-0374	3		CAPACITOR-FXD 10UF+-10% 20VDC TA	56289	150D106X9020B2
A9C203	0160-0174	9		CAPACITOR-FXD .47UF +80-20% 25VDC CER	28480	0160-0174
A9C204	0160-4209	9		CAPACITOR-FXD .01UF +-20% 50VDC POLYE	28480	0160-4209
A9C205	0140-0196	3		CAPACITOR-FXD 150PF +-5% 300VDC MICA	72136	DM15F151J0300MV1CR
A9C206	0160-0571			C-FXD470PF		
A9C302	0160-3220	2	1	CAPACITOR-FXD 6800PF +-5% 250VDC	28480	0160-3220
A9C303	0160-0197	8		CAPACITOR-FXD 2.2UF+-10% 20VDC TA	56289	150D225X9020A2
A9C304	0160-0197	8		CAPACITOR-FXD 2.2UF+-10% 20VDC TA	56289	150D225X9020A2
A9C401	0160-0116	1		CAPACITOR-FXD 6.8UF+-10% 35VDC TA	56289	150D685X9035B2
A9C402	0160-0174	9		CAPACITOR-FXD .47UF +80-20% 25VDC CER	28480	0160-0174
A9C403	0160-4212	4		CAPACITOR-FXD .068UF +-20% 50VDC POLYE	28480	0160-4212
A9C404	0160-0174	9		CAPACITOR-FXD .47UF +80-20% 25VDC CER	28480	0160-0174
A9C405	0160-1704	5		CAPACITOR-FXD .47UF+-10% 6VDC TA	56289	150D476X9006B2
A9C501	0160-0174	9		CAPACITOR-FXD .47UF +80-20% 25VDC CER	28480	0160-0174
A9C502	0160-0174	9		CAPACITOR-FXD .47UF +80-20% 25VDC CER	28480	0160-0174
A9C503	0160-0576	5		CAPACITOR-FXD .1UF +-20% 50VDC CER	28480	0160-0576
A9C602	0121-0165	6	1	CAPACITOR-V TRMP-CER 7-25PF 350V PC-MTG	52763	304324 7/25PF N300
A9C603	0160-0174	9		CAPACITOR-FXD .47UF +80-20% 25VDC CER	28480	0160-0174
A9C604	0160-4209	9		CAPACITOR-FXD .01UF +-20% 50VDC POLYE	28480	0160-4209
A9C701	0160-2055	9		CAPACITOR-FXD .01UF +80-20% 100VDC CER	28480	0160-2055
A9C702	0160-2055	9		CAPACITOR-FXD .01UF +80-20% 100VDC CER	28480	0160-2055
A9C703	0160-4210	2		CAPACITOR-FXD .022UF +-20% 50VDC POLYE	28480	0160-4210
A9C704	0140-0190	7	1	CAPACITOR-FXD 30PF +-5% 300VDC MICA	72136	DM15E390J0300MV1CR
A9C705	0160-0174	9		CAPACITOR-FXD .47UF +80-20% 25VDC CER	28480	0160-0174
A9C706	0160-4213	5		CAPACITOR-FXD .1UF +-20% 50VDC POLYE	28480	0160-4213
A9CR201	1901-0040	1		DIODE-SWITCHING 30V 50MA 2NS DO-35	28480	1901-0040
A9CR202	1901-0040	1		DIODE-SWITCHING 30V 50MA 2NS DO-35	28480	1901-0040
A9CR301	1901-0040	1		DIODE-SWITCHING 30V 50MA 2NS DO-35	28480	1901-0040
A9CR302	1901-0040	1		DIODE-SWITCHING 30V 50MA 2NS DO-35	28480	1901-0040
A9CR303	1901-0040	1		DIODE-SWITCHING 30V 50MA 2NS DO-35	28480	1901-0040
A9CR304	1901-0040	1		DIODE-SWITCHING 30V 50MA 2NS DO-35	28480	1901-0040
A9CR501	1901-0040	1		DIODE-SWITCHING 30V 50MA 2NS DO-35	28480	1901-0040
A9CR502	1901-0040	1		DIODE-SWITCHING 30V 50MA 2NS DO-35	28480	1901-0040
A9CR503	1901-0040	1		DIODE-SWITCHING 30V 50MA 2NS DO-35	28480	1901-0040
A9CR504	1901-0040	1		DIODE-SWITCHING 30V 50MA 2NS DO-35	28480	1901-0040
A9CR505	1901-0040	1		DIODE-SWITCHING 30V 50MA 2NS DO-35	28480	1901-0040
A9CR506	1901-0040	1		DIODE-SWITCHING 30V 50MA 2NS DO-35	28480	1901-0040
A9CR507	1901-0040	1		DIODE-SWITCHING 30V 50MA 2NS DO-35	28480	1901-0040
A9CR508	1901-0040	1		DIODE-SWITCHING 30V 50MA 2NS DO-35	28480	1901-0040
A9CR509	1901-0040	1		DIODE-SWITCHING 30V 50MA 2NS DO-35	28480	1901-0040
A9CR510	1901-0040	1		DIODE-SWITCHING 30V 50MA 2NS DO-35	28480	1901-0040
A9CR511	1901-0040	1		DIODE-SWITCHING 30V 50MA 2NS DO-35	28480	1901-0040
A9CR512	1901-0040	1		DIODE-SWITCHING 30V 50MA 2NS DO-35	28480	1901-0040
A9CR601	1901-0040	1		DIODE-SWITCHING 30V 50MA 2NS DO-35	28480	1901-0040
A9CR701	1901-0040	1		DIODE-SWITCHING 30V 50MA 2NS DO-35	28480	1901-0040
A9CR702	1901-0040	1		DIODE-SWITCHING 30V 50MA 2NS DO-35	28480	1901-0040
A9CR703	1901-0040	1		DIODE-SWITCHING 30V 50MA 2NS DO-35	28480	1901-0040
A9CR704	1901-0040	1		DIODE-SWITCHING 30V 50MA 2NS DO-35	28480	1901-0040
A9Q201	1854-0215	1		TRANSISTOR NPN SI PD=350MW FT=300MHZ	04713	2N3904
A9Q202	1854-0215	1		TRANSISTOR NPN SI PD=350MW FT=300MHZ	04713	2N3904
A9Q301	1853-0400	4		TRANSISTOR PNP SI DARL TC=92 PD=500MW	28480	1853-0400
A9Q302	1853-0086	2		TRANSISTOR PNP SI PD=310MW FT=40MHZ	27014	2N5087
A9Q303	1854-0392	5		TRANSISTOR NPN SI PD=310MW FT=50MHZ	04713	2N5088
A9Q304	1853-0036	2		TRANSISTOR PNP SI PD=310MW FT=250MHZ	28480	1853-0036
A9Q305	1854-0215	1		TRANSISTOR NPN SI PD=350MW FT=300MHZ	04713	2N3904
A9Q306	1853-0036	2		TRANSISTOR PNP SI PD=310MW FT=250MHZ	28480	1853-0036
A9Q501	1854-0215	1		TRANSISTOR NPN SI PD=350MW FT=300MHZ	04713	2N3904
A9Q502	1854-0215	1		TRANSISTOR NPN SI PD=350MW FT=300MHZ	04713	2N3904
A9Q503	1853-0036	2		TRANSISTOR PNP SI PD=310MW FT=250MHZ	28480	1853-0036
A9Q504	1853-0036	2		TRANSISTOR PNP SI PD=310MW FT=250MHZ	28480	1853-0036
A9Q601	1853-0036	2		TRANSISTOR PNP SI PD=310MW FT=250MHZ	28480	1853-0036
A9Q701	1855-0062	8	1	TRANSISTOR J-FET N-CHAN D-MODE SI	28480	1855-0062

Table 6-3. Replaceable Parts (cont'd)

Reference Designation	HP Part Number	C D	Qty	Description	Mfr Code	Mfr Part Number
A9R101	069A-3155	1		RESISTOR 4.64K 1% .125W F TC0+/-100	24546	C4-1/8-T0=4641-F
A9R201	069A-4433	0		RESISTOR 2.26K 1% .125W F TC0+/-100	24546	C4-1/8-T0=2261-F
A9R202	069A-4433	0		RESISTOR 2.26K 1% .125W F TC0+/-100	24546	C4-1/8-T0=2261-F
A9R203	0757-0444	1		RESISTOR 12.1K 1% .125W F TC0+/-100	24546	C4-1/8-T0=1212-F
A9R204	0757-0444	1		RESISTOR 12.1K 1% .125W F TC0+/-100	24546	C4-1/8-T0=1212-F
A9R205	0698-0084	5		R-FXD 2.15K 1%	24546	C4-1/8-T0=1213-F
A9R206	0757-0444	1		RESISTOR 12.1K 1% .125W F TC0+/-100	24546	C4-1/8-T0=1212-F
A9R207	0757-0439	4		RESISTOR 6.81K 1% .125W F TC0+/-100	24546	C4-1/8-T0=6811-F
A9R208	0698-4433	0		RESISTOR 2.26K 1% .125W F TC0+/-100	24546	C4-1/8-T0=2261-F
A9R209	0757-0444	1		RESISTOR 12.1K 1% .125W F TC0+/-100	24546	C4-1/8-T0=1212-F
A9R210	0698-3260	9		RESISTOR 464K 1% .125W F TC0+/-100	28480	0698-3260
A9R211	0757-0442	9		RESISTOR 10K 1% .125W F TC0+/-100	24546	C4-1/8-T0=1002-F
A9R212	0757-0444	1		RESISTOR 12.1K 1% .125W F TC0+/-100	24546	C4-1/8-T0=1212-F
A9R213	0698-4437	1		R-FXD 2.94K 1% .125W	24546	C4-1/8-T0=4021-F
A9R214	0698-4433	0		RESISTOR 2.26K 1% .125W F TC0+/-100	24546	C4-1/8-T0=2261-F
A9R301	069A-6942	0	3	RESISTOR 25K .1% .125W F TC0+/-50	28480	0698-6942
A9R302	0698-6942	0		RESISTOR 25K .1% .125W F TC0+/-50	28480	0698-6942
A9R303	0698-6608	5		RESISTOR 23.5K .1% .125W F TC0+/-25	28480	0698-6608
A9R304	0698-6942	0		RESISTOR 25K .1% .125W F TC0+/-50	28480	0698-6942
A9R306	0757-0280	3		RESISTOR 1K 1% .125W F TC0+/-100	24546	C4-1/8-T0=1001-F
A9R307	0757-0280	3		RESISTOR 1K 1% .125W F TC0+/-100	24546	C4-1/8-T0=1001-F
A9R308	0698-3558	8		RESISTOR 4.02K 1% .125W F TC0+/-100	24546	C4-1/8-T0=4021-F
A9R309	0698-3558	8		RESISTOR 4.02K 1% .125W F TC0+/-100	24546	C4-1/8-T0=4021-F
A9R310	2100-3207	1		RESISTOR-TMR 5x 10% C SIDE-ADJ 1-TRN	28480	2100-3207
A9R311	0757-0444	1		RESISTOR 12.1K 1% .125W F TC0+/-100	24546	C4-1/8-T0=1212-F
A9R312	0757-0274	5		RESISTOR 1.21K 1% .125W F TC0+/-100	24546	C4-1/8-T0=1213-F
A9R313	2100-3353	8	1	RESISTOR-TRMR 20K 10% C SIDE-ADJ 1-TRN	32997	3386x-Y46=203
A9R314	0757-0407	6		RESISTOR 200 1% .125W F TC0+/-100	24546	C4-1/8-T0=201-F
A9R315	0698-3136	8		RESISTOR 17.8K 1% .125W F TC0+/-100	24546	C4-1/8-T0=1782-F
A9R316	0698-3155	1		RESISTOR 4.64K 1% .125W F TC0+/-100	24546	C4-1/8-T0=4641-F
A9R401	0698-3156	2		RESISTOR 14.7K 1% .125W F TC0+/-100	24546	C4-1/8-T0=1472-F
A9R402	0757-0394	0		RESISTOR 51.1 1% .125W F TC0+/-100	24546	C4-1/8-T0=5111-F
A9R403	0757-0394	0		RESISTOR 51.1 1% .125W F TC0+/-100	24546	C4-1/8-T0=5111-F
A9R404	0757-0442	9		RESISTOR 10K 1% .125W F TC0+/-100	24546	C4-1/8-T0=1002-F
A9R405	0757-0442	9		RESISTOR 10K 1% .125W F TC0+/-100	24546	C4-1/8-T0=1002-F
A9R406	2100-3103	6		RESISTOR-TRMR 10K 10% C SIDE-ADJ 17-TRN	02111	43P103
A9R407	0698-0082	7		RESISTOR 464 1% .125W F TC0+/-100	24546	C4-1/8-T0=4640-F
A9R408	0757-0394	0		RESISTOR 51.1 1% .125W F TC0+/-100	24546	C4-1/8-T0=5111-F
A9R409	0757-0280	3		RESISTOR 1K 1% .125W F TC0+/-100	24546	C4-1/8-T0=1001-F
A9R410	0757-0280	3		RESISTOR 1K 1% .125W F TC0+/-100	24546	C4-1/8-T0=1001-F
A9R411	0757-0439	4		RESISTOR 6.81K 1% .125W F TC0+/-100	24546	C4-1/8-T0=6811-F
A9R412	0698-3154	0		RESISTOR 4.22K 1% .125W F TC0+/-100	24546	C4-1/8-T0=4221-F
A9R413	0698-3154	0		RESISTOR 4.22K 1% .125W F TC0+/-100	24546	C4-1/8-T0=4221-F
A9R414	0757-0280	3		RESISTOR 1K 1% .125W F TC0+/-100	24546	C4-1/8-T0=1001-F
A9R501	0757-0283	6		RESISTOR 2K 1% .125W F TC0+/-100	24546	C4-1/8-T0=2001-F
A9R502	0698-3437	2		RESISTOR 133 1% .125W F TC0+/-100	24546	C4-1/8-T0=133R-F
A9R503	0757-0280	3		RESISTOR 1K 1% .125W F TC0+/-100	24546	C4-1/8-T0=1001-F
A9R504	0698-3437	2		RESISTOR 133 1% .125W F TC0+/-100	24546	C4-1/8-T0=133R-F
A9R505	0757-0399	5	2	RESISTOR 82.5 1% .125W F TC0+/-100	24546	C4-1/8-T0=82R5-F
A9R506	0698-0082	7		RESISTOR 464 1% .125W F TC0+/-100	24546	C4-1/8-T0=4640-F
A9R507	0757-0399	5		RESISTOR 82.5 1% .125W F TC0+/-100	24546	C4-1/8-T0=82R5-F
A9R508	0698-4037	0		RESISTOR 46.4 1% .125W F TC0+/-100	24546	C4-1/8-T0=46R4-F
A9R509	0757-0411	2		RESISTOR 332 1% .125W F TC0+/-100	24546	C4-1/8-T0=332R-F
A9R510	0698-4037	0		RESISTOR 46.4 1% .125W F TC0+/-100	24546	C4-1/8-T0=46R4-F
A9R511	0757-0388	2		RESISTOR 30.1 1% .125W F TC0+/-100	24546	C4-1/8-T0=30R1-F
A9R512	0757-0403	2	1	RESISTOR 121 1% .125W F TC0+/-100	24546	C4-1/8-T0=121R-F
A9R513	0757-0388	2		RESISTOR 30.1 1% .125W F TC0+/-100	24546	C4-1/8-T0=30R1-F
A9R514	069A-3435	0	3	RESISTOR 38.3 1% .125W F TC0+/-100	24546	C4-1/8-T0=38R3-F
A9R515	069A-3435	0		RESISTOR 38.3 1% .125W F TC0+/-100	24546	C4-1/8-T0=38R3-F
A9R516	0757-0444	1		RESISTOR 12.1K 1% .125W F TC0+/-100	24546	C4-1/8-T0=1212-F
A9R517	0698-3136	8		RESISTOR 17.8K 1% .125W F TC0+/-100	24546	C4-1/8-T0=1782-F
A9R518	0757-0433	8		RESISTOR 3.32K 1% .125W F TC0+/-100	24546	C4-1/8-T0=3321-F
A9R519	0757-1094	9		RESISTOR 1.47K 1% .125W F TC0+/-100	24546	C4-1/8-T0=1471-F
A9R520	0757-1094	9		RESISTOR 1.47K 1% .125W F TC0+/-100	24546	C4-1/8-T0=1471-F
A9R521	0757-0433	8		RESISTOR 3.32K 1% .125W F TC0+/-100	24546	C4-1/8-T0=3321-F
A9R522	0757-0444	1		RESISTOR 12.1K 1% .125W F TC0+/-100	24546	C4-1/8-T0=1212-F
A9R523	069A-3136	8		RESISTOR 17.8K 1% .125W F TC0+/-100	24546	C4-1/8-T0=1782-F
A9R601	0698-0082	7		RESISTOR 464 1% .125W F TC0+/-100	24546	C4-1/8-T0=4640-F
A9R602	0757-0424	7		RESISTOR 1.1K 1% .125W F TC0+/-100	24546	C4-1/8-T0=1101-F
A9R603	0757-1094	9		RESISTOR 1.47K 1% .125W F TC0+/-100	24546	C4-1/8-T0=1471-F
A9R604	0757-1094	9		RESISTOR 1.47K 1% .125W F TC0+/-100	24546	C4-1/8-T0=1471-F
A9R605	0757-1094	9		RESISTOR 1.47K 1% .125W F TC0+/-100	24546	C4-1/8-T0=1471-F
A9R606	0757-1094	9		RESISTOR 1.47K 1% .125W F TC0+/-100	24546	C4-1/8-T0=1471-F
A9R607	0698-3435	0		RESISTOR 38.3 1% .125W F TC0+/-100	24546	C4-1/8-T0=38R3-F
A9R608	0698-4420	5		RESISTOR 226 1% .125W F TC0+/-100	24546	C4-1/8-T0=226R-F

Table 6-3. Replaceable Parts (cont'd)

Reference Designation	HP Part Number	C D	Qty	Description	Mfr Code	Mfr Part Number
A9R609	0757-0422	5		RESISTOR 909 1% .125W F TC=0+100	24546	C4-1/8-T0-909R-F
A9R610	0757-1094	9		RESISTOR 1.47K 1% .125W F TC=0+100	24546	C4-1/8-T0-1471-F
A9R611	0757-0419	0		RESISTOR 681 1% .125W F TC=0+100	24546	C4-1/8-T0-681R-F
A9H701	0757-0454	3		RESISTOR 33.2K 1% .125W F TC=0+100	24546	C4-1/8-T0-3322-F
A9R702	0698-3136	8		RESISTOR 17.8K 1% .125W F TC=0+100	24546	C4-1/8-T0-1782-F
A9R703	0757-0454	3		RESISTOR 33.2K 1% .125W F TC=0+100	24546	C4-1/8-T0-3322-F
A9R704	0698-3136	8		RESISTOR 17.8K 1% .125W F TC=0+100	24546	C4-1/8-T0-1782-F
A9R705	0757-0467	8		RESISTOR 121K 1% .125W F TC=0+100	24546	C4-1/8-T0-1213-F
A9R706	0698-3136	8		RESISTOR 17.8K 1% .125W F TC=0+100	24546	C4-1/8-T0-1782-F
A9R707	0698-0085	0		RESISTOR 2.61K 1% .125W F TC=0+100	24546	C4-1/8-T0-2611-F
A9R708	0757-0280	3		RESISTOR 1K 1% .125W F TC=0+100	24546	C4-1/8-T0-1001-F
A9R709	0757-0274	5		RESISTOR 1.21K 1% .125W F TC=0+100	24546	C4-1/8-T0-1213-F
A9U101	1820-1963	7		IC FF CMOS D-TYPE POS-EDGE-TRIG DUAL	01928	CD40138AE
A9U102	1820-1963	7		IC FF CMOS D-TYPE POS-EDGE-TRIG DUAL	01928	CD40138AE
A9U103	1820-1747	5	2	IC GATE CMOS NAND QUAD 2-INP	04713	MC140118CP
A9U104	1820-1745	3		IC GATE CMOS NOR QUAD 2-INP	04713	MC140018CP
A9U105	1820-1956	8		IC LCH CMOS COM CLOCK QUAD	01928	CD4042BE
A9U106	1820-1963	7		IC FF CMOS D-TYPE POS-EDGE-TRIG DUAL	01928	CD40138AE
A9U107	1820-1956	8		IC LCH CMOS COM CLOCK QUAD	01928	CD4042BE
A9U108	1820-1956	8		IC LCH CMOS COM CLOCK QUAD	01928	CD4042BE
A9U109	1820-1956	8		IC LCH CMOS COM CLOCK QUAD	01928	CD4042BE
A9U110	1820-1956	8		IC LCH CMOS COM CLOCK QUAD	01928	CD4042BE
A9U111	1820-1747	5		IC GATE CMOS NAND QUAD 2-INP	04713	MC140118CP
A9U112	1820-1442	7	10	IC CNTR TTL LS DECD ASYNCHRO	01295	SN74LS290N
A9U113	1820-1442	7		IC CNTR TTL LS DECD ASYNCHRO	01295	SN74LS290N
A9U114	1820-1198	0	1	IC GATE TTL LS NAND QUAD 2-INP	01295	SN74LS03N
A9U115	1820-1442	7		IC CNTR TTL LS DECD ASYNCHRO	01295	SN74LS290N
A9U201	1820-1279	8	5	IC CNTR TTL LS DECD UP/DOWN SYNCHRO	01295	SN74LS190N
A9U202	1820-1279	8		IC CNTR TTL LS DECD UP/DOWN SYNCHRO	01295	SN74LS190N
A9U203	1820-1112	8	1	IC FF TTL LS D-TYPE POS-EDGE-TRIG	01295	SN74LS74N
A9U204	1820-1202	7	2	IC GATE TTL LS NAND TPL 3-INP	01295	SN74LS10N
A9U205	1820-1197	9		IC GATE TTL LS NAND QUAD 2-INP	01295	SN74LS00N
A9U206	1820-1963	7		IC FF CMOS D-TYPE POS-EDGE-TRIG DUAL	01928	CD40138AE
A9U207	1826-0043	4		IC OP AMP GP TO-99	01928	CA307T
A9U208	1820-1188	8		IC PL LOOP 16-DIP-P	01928	CD4046AF
A9U209	1820-1442	7		IC CNTR TTL LS DECD ASYNCHRO	01295	SN74LS290N
A9U210	1820-1442	7		IC CNTR TTL LS DECD ASYNCHRO	01295	SN74LS290N
A9U301	1826-0111	7		IC OP AMP GP DUAL TO-99	04713	MC1458G
A9U302	1826-0043	4		IC OP AMP GP TO-99	01928	CA307T
A9U303	1826-0043	4		IC OP AMP GP TO-99	01928	CA307T
A9U304	1826-0111	7		IC OP AMP GP DUAL TO-99	04713	MC1458G
A9U401	1820-0427	6	1	IC MODULATOR TO-100	04713	MC1496G
A9U601	1820-0802	1		IC GATE ECL NOR QUAD 2-INP	04713	MC10102P
A9U602	1820-1442	7		IC CNTR TTL LS DECD ASYNCHRO	01295	SN74LS290N
A9U603	1820-1122	0	2	IC CNTR CMOS BCD SYNCHRO DUAL	04713	MC145188CP
A9U701	1820-1279	8		IC CNTR TTL LS DECD UP/DOWN SYNCHRO	01295	SN74LS190N
A9U702	1820-1279	8		IC CNTR TTL LS DECD UP/DOWN SYNCHRO	01295	SN74LS190N
A9U703	1820-1279	8		IC CNTR TTL LS DECD UP/DOWN SYNCHRO	01295	SN74LS190N
A9U704	1820-0629	0	2	IC FF TTL S J-K NEG-EDGE-TRIG	01295	SN74LS112N
A9U705	1820-1197	9		IC GATE TTL LS NAND QUAD 2-INP	01295	SN74LS00N
A9U706	1820-1202	7		IC GATE TTL LS NAND TPL 3-INP	01295	SN74LS10N
A9U707	1820-1963	7		IC FF CMOS D-TYPE POS-EDGE-TRIG DUAL	01928	CD40138AE
A9U708	1820-0567	5	1	IC MV TTL DUAL	04713	MC4024P
A9U709	1820-1442	7		IC CNTR TTL LS DECD ASYNCHRO	01295	SN74LS290N
A9U710	1820-1442	7		IC CNTR TTL LS DECD ASYNCHRO	01295	SN74LS290N
A9U711	1820-1122	0		IC CNTR CMOS BCD SYNCHRO DUAL	04713	MC145188CP
A9VR201	1902-0048	1		DIODE-ZNR 6.81V 5% DO-7 PD=.4W TC=+.043X	28480	1902-0048
A9VR301	1902-3036	3	2	DIODE-ZNR 3.16V 5% DO-7 PD=.4W TC=+.064X	28480	1902-3036
A9VR302	1902-3036	3		DIODE-ZNR 3.16V 5% DO-7 PD=.4W TC=+.064X	28480	1902-3036
A9VR401	1902-3139	7	1	DIODE-ZNR 8.25V 5% DO-7 PD=.4W TC=+.053X	28480	1902-3139
A9VR501	1902-0025	4		DIODE-ZNR 10V 5% DO-7 PD=.4W TC=+.06X	28480	1902-0025
A9VR502	1902-0025	4		DIODE-ZNR 10V 5% DO-7 PD=.4W TC=+.06X	28480	1902-0025
A9VR701	1902-3182	0		DIODE-ZNR 12.1V 5% DO-7 PD=.4W TC=+.064X	28480	1902-3182
A9Y601	0410-0423	2	1	CRYSTAL-QUARTZ (MISC ITEM)	28480	0410-0423
A10	08165-66510	5	1	BOARD ASSEMBLY, LCM FREQUENCY G	28480	08165-66510
A10C1	0160-2257	3		CAPACITOR-FXD 10PF +-5% 500VDC CER 0+-60	28480	0160-2257
A10C2	0160-0116	1		CAPACITOR-FXD 6.8UF+-10% 15VDC TA	56289	1500685X9035B2
A10C3	0160-4209	9		CAPACITOR-FXD .01UF +-20% 50VDC POLYE	28480	0160-4209
A10C4	0160-4209	9		CAPACITOR-FXD .01UF +-20% 50VDC POLYE	28480	0160-4209
A10C5	0160-4209	9		CAPACITOR-FXD .01UF +-20% 50VDC POLYE	28480	0160-4209

Table 6-3. Replaceable Parts (cont'd)

Reference Designation	HP Part Number	C D	Qty	Description	Mfr Code	Mfr Part Number
A10C6	0160-2208	4	1	CAPACITOR-FXD 330PF +-5% 300VDC MICA	28480	0160-2208
A10C7	0160-4209	1		CAPACITOR-FXD .01UF +-20% 50VDC POLYE	28480	0160-4209
A10C201	0180-0116	9		CAPACITOR-FXD 6.8UF+-10% 35VDC TA	56289	150D85X9035B2
A10C202	0180-0197	8		CAPACITOR-FXD 2.2UF+-10% 20VDC TA	56289	150D225X9020A2
A10C203	0180-0374	3		CAPACITOR-FXD 10UF+-10% 20VDC TA	56289	150D106X9020B2
A10C204	0160-0174	9		CAPACITOR-FXD .47UF +-80-20% 25VDC CER	28480	0160-0174
A10C205	0140-0193	0		CAPACITOR-FXD 82PF +-5% 300VDC MICA	72136	DM15E820J0300WV1CR
A10C206	0140-0192	9		CAPACITOR-FXD 68PF +-5% 300VDC MICA	72136	DM15E680J0300WV1CR
A10C207	0160-2055	9		CAPACITOR-FXD .01UF +-80-20% 100VDC CER	28480	0160-2055
A10C208	0160-4210	2		CAPACITOR-FXD .022UF +-20% 50VDC POLYE	28480	0160-4210
A10C209	0160-2055	9		CAPACITOR-FXD .01UF +-80-20% 100VDC CER	28480	0160-2055
A10CR201	1901-0040	1		DIODE-SWITCHING 30V 50MA 2NS DO-35	28480	1901-0040
A10CR202	1901-0040	1		DIODE-SWITCHING 30V 50MA 2NS DO-35	28480	1901-0040
A10MP1	4040-0749	4	1	EXTR-PC BD BRN POLYC .062-RD-TMKNS	28480	4040-0749
	5000-8991	1	1	TERMINAL, TEST POINT	28480	5000-8991
A10Q201	1854-0583	6		TRANSISTOR NPN SI TO-92 PD=310MW	04713	MP8-A18
A10Q202	1854-0583	6		TRANSISTOR NPN SI TO-92 PD=310MW	04713	MP8-A18
A10Q203	1854-0583	6		TRANSISTOR NPN SI TO-92 PD=310MW	04713	MP8-A18
A10Q204	1853-0281	9		TRANSISTOR PNP 2N2907A SI TO-18 PD=400MW	04713	2N2907A
A10Q205	1853-0036	2		TRANSISTOR PNP SI PD=310MW FT=250MHZ	28480	1853-0036
A10Q206	1854-0215	1		TRANSISTOR NPN SI PD=350MW FT=300MHZ	04713	2N3904
A10R1	0698-4471	6		RESISTOR 7.15K 1% .125W F TC=0+-100	24546	C4-1/8-T0-7151-F
A10R201	0698-3540	1		RESISTOR 15.4K 1% .125W F TC=0+-100	24546	C4-1/8-T0-1542-F
A10R202	0698-4442	8		RESISTOR 4.42K 1% .125W F TC=0+-100	24546	C4-1/8-T0-4421-F
A10R203	0698-355A	8		RESISTOR 4.02K 1% .125W F TC=0+-100	24546	C4-1/8-T0-4021-F
A10R204	0698-4453	4		RESISTOR 402 1% .125W F TC=0+-100	24546	C4-1/8-T0-402R-F
A10R205	0757-0280	3		RESISTOR 1K 1% .125W F TC=0+-100	24546	C4-1/8-T0-1001-F
A10R206	2100-3154	7		RESISTOR-TRMR 1K 10% C SIDE-ADJ 17-TRN	02111	43P102
A10R207	0698-3558	8		RESISTOR 4.02K 1% .125W F TC=0+-100	24546	C4-1/8-T0-4021-F
A10R208	0757-0428	1		RESISTOR 1.62K 1% .125W F TC=0+-100	24546	C4-1/8-T0-1621-F
A10R209	0698-3484	9	1	RESISTOR 6.65K 1% .125W F TC=0+-100	24546	C4-1/8-T0-6651-F
A10R210	0757-0441	8		RESISTOR 8.25K 1% .125W F TC=0+-100	24546	C4-1/8-T0-8251-F
A10R211	0757-0401	7		RESISTOR 100 1% .125W F TC=0+-100	24546	C4-1/8-T0-101-F
A10R212	2100-3154	0		RESISTOR-TRMR 1K 10% C SIDE-ADJ 17-TRN	02111	43P102
A10R213	0698-3558	8		RESISTOR 4.02K 1% .125W F TC=0+-100	24546	C4-1/8-T0-4021-F
A10R214	0757-0280	3		RESISTOR 1K 1% .125W F TC=0+-100	24546	C4-1/8-T0-1001-F
A10R215	0698-4425	0		RESISTOR 1.54K 1% .125W F TC=0+-100	24546	C4-1/8-T0-1541-F
A10R216	0698-4477	2	1	RESISTOR 10.5K 1% .125W F TC=0+-100	24546	C4-1/8-T0-1052-F
A10R217	0698-3156	2		RESISTOR 14.7K 1% .125W F TC=0+-100	24546	C4-1/8-T0-1472-F
A10R218	0757-0458	7		RESISTOR 51.1K 1% .125W F TC=0+-100	24546	C4-1/8-T0-5112-F
A10R219	0698-4435	2		RESISTOR 2.49K 1% .125W F TC=0+-100	24546	C4-1/8-T0-2491-F
A10R220	0698-3451	0		RESISTOR 133K 1% .125W F TC=0+-100	24546	C4-1/8-T0-1333-F
A10R221	0757-0465	6		RESISTOR 100K 1% .125W F TC=0+-100	24546	C4-1/8-T0-1003-F
A10R222	0698-3451	0		RESISTOR 133K 1% .125W F TC=0+-100	24546	C4-1/8-T0-1333-F
A10R223	0698-3451	0		RESISTOR 133K 1% .125W F TC=0+-100	24546	C4-1/8-T0-1333-F
A10R224	0698-4207	6	1	RESISTOR 44.2K 1% .125W F TC=0+-100	24546	C4-1/8-T0-4422-F
A10R225	0757-0442	9		RESISTOR 10K 1% .125W F TC=0+-100	24546	C4-1/8-T0-1002-F
A10R226	0698-4471	6		RESISTOR 7.15K 1% .125W F TC=0+-100	24546	C4-1/8-T0-7151-F
A10R227	2100-3109	2	2	RESISTOR-TRMR 2K 10% C SIDE-ADJ 17-TRN	02111	43P202
A10R230	0757-0458	7		RESISTOR 51.1K 1% .125W F TC=0+-100	24546	C4-1/8-T0-5112-F
A10R231	0757-0349	5		RESISTOR 22.6K 1% .125W F TC=0+-100	24546	C4-1/8-T0-2262-F
A10R232	0757-0349	5		RESISTOR 22.6K 1% .125W F TC=0+-100	24546	C4-1/8-T0-2262-F
A10R233	0757-0458	7		RESISTOR 51.1K 1% .125W F TC=0+-100	24546	C4-1/8-T0-5112-F
A10R234	0757-0280	3		RESISTOR 1K 1% .125W F TC=0+-100	24546	C4-1/8-T0-1001-F
A10R235	2100-3123	0	1	RESISTOR-TRMR 500 10% C SIDE-ADJ 17-TRN	02111	43P501
A10R236	0698-4014	3	1	RESISTOR 7A7 1% .125W F TC=0+-100	24546	C4-1/8-T0-787R-F
A10R237	0757-0458	7		RESISTOR 51.1K 1% .125W F TC=0+-100	24546	C4-1/8-T0-5112-F
A10R238	0757-0458	7		RESISTOR 51.1K 1% .125W F TC=0+-100	24546	C4-1/8-T0-5112-F
A10R239	0757-0458	7		RESISTOR 51.1K 1% .125W F TC=0+-100	24546	C4-1/8-T0-5112-F
A10R240	0698-0082	9		RESISTOR 464 1% .125W F TC=0+-100	24546	C4-1/8-T0-4640-F
A10R241	2100-3122	9	2	RESISTOR-TRMR 100 10% C SIDE-ADJ 17-TRN	02111	43P101
A10R242	0757-0442	9		RESISTOR 10K 1% .125W F TC=0+-100	24546	C4-1/8-T0-1002-F
A10R243	0698-4486	3		RESISTOR 24.9K 1% .125W F TC=0+-100	24546	C4-1/8-T0-2492-F
A10R244	0757-0458	7		RESISTOR 51.1K 1% .125W F TC=0+-100	24546	C4-1/8-T0-5112-F
A10R245	0698-0082	7		RESISTOR 464 1% .125W F TC=0+-100	24546	C4-1/8-T0-4640-F
A10R246	0698-3132	4		RESISTOR 261 1% .125W F TC=0+-100	24546	C4-1/8-T0-2610-F
A10U1	1820-1199	1		IC INV TTL LS HEX 1-INP	01295	SN74LS04N
A10U2	1820-1423	4		IC MV TTL LS MONOSTBL RETRIG DUAL	01295	SN74LS123N
A10U3	1820-1442	7		IC CNTR TTL LS DECD ASYNCHRO	01295	SN74LS290N
A10U4	1820-1442	7		IC CNTR TTL LS DECD ASYNCHRO	01295	SN74LS290N
A10U5	1820-1244	7	1	IC MUXR/DATA=SEL TTL LS 4-T0-1-LINE DUAL	01295	SN74LS153N
A10U6	1820-0629	0		IC FF TTL S J-K NEG-EDGE-TRIG	01295	SN74S112N
A10U7	1820-1197	9		IC GATE TTL LS NAND QUAD 2-INP	01295	SN74LS00N
A10U8	1820-1212	9	1	IC FF TTL LS J-K NEG-EDGE-TRIG	01295	SN74LS112N
A10U9	1820-1197	9		IC GATE TTL LS NAND QUAD 2-INP	01295	SN74LS00N
A10U10	1820-1262	9	1	IC CNTR TTL DECD ASYNCHRO NEG-EDGE-TRIG	01295	SN74290N

Table 6-3. Replaceable Parts (cont'd)

Reference Designation	HP Part Number	C D	Qty	Description	Mfr Code	Mfr Part Number
A10U11	1820-1443	8	1	IC CNTR TTL LS BIN ASYNCHRO	01295	SN74LS293N
A10U12	1820-1197	9		IC GATE TTL LS NAND QUAD 2-INP	01295	SN74LS00N
A10U13	1820-1144	6		IC GATE TTL LS NOR QUAD 2-INP	01295	SN74LS02N
A10U14	1820-1197	9		IC GATE TTL LS NAND QUAD 2-INP	01295	SN74LS00N
A10U15	1820-1211	8	1	IC GATE TTL LS EXCL-OR QUAD 2-INP	01295	SN74LS86N
A10U16	1820-1278	7	3	IC CNTR TTL LS BIN UP/DOWN SYNCHRO	01295	SN74LS191N
A10U17	1820-1278	7		IC CNTR TTL LS BIN UP/DOWN SYNCHRO	01295	SN74LS191N
A10U18	1820-1278	7		IC CNTR TTL LS BIN UP/DOWN SYNCHRO	01295	SN74LS191N
A10U19	1820-1284	5	1	IC GATE TTL LS AND-OR-INV 4-INP	01295	SN74LS55N
A10U20	1820-1207	2	2	IC GATE TTL LS NAND 8-INP	01295	SN74LS30N
A10U21	1820-1207	2		IC GATE TTL LS NAND 8-INP	01295	SN74LS30N
A10U101	1820-1745	3		IC GATE CMOS NOR QUAD 2-INP	04713	MC14001BCP
A10U102	1820-1745	3		IC GATE CMOS NOR QUAD 2-INP	04713	MC14001BCP
A10U103	1820-1963	7		IC FF CMOS D-TYPE POS-EDGE-TRIG DUAL	01928	CD4013BAE
A10U104	1820-1956	8		IC LCH CMOS CDM CLOCK QUAD	01928	CD4042BE
A10U105	1820-1956	5		IC LCH CMOS CDM CLOCK QUAD	01928	CD4042BE
A10U106	1820-1956	8		IC LCH CMOS CDM CLOCK QUAD	01928	CD4042BE
A10U201	1826-0188	8		IC CONV B=B-D/A 16-DIP=C	04713	MC1408L-8
A10U202	1826-0111	7		IC OP AMP GP DUAL TO-99	04713	MC1458G
A10U203	1826-0111	7		IC OP AMP GP DUAL TO-99	04713	MC1458G
A10U204	1826-0111	7		IC OP AMP GP DUAL TO-99	04713	MC1458G
A10VR201	1902-0025	4		DIODE-ZNR 10V 5% DO-7 PD=.4W TC=+.06%	28480	1902-0025
A10VR202	1902-0041	4		DIODE-ZNR 5.11V 5% DO-7 PD=.4W TC=+.009%	28480	1902-0041
A10VR203	1902-0786	4		DIODE-ZNR 1N937 9V 5% DO-7 PD=.5W	24046	1N937
A10VR204	1902-0786	4		DIODE-ZNR 1N937 9V 5% DO-7 PD=.5W	24046	1N937
A10VR205	1902-0025	4		DIODE-ZNR 10V 5% DO-7 PD=.4W TC=+.06%	28480	1902-0025
A12	08165-66512	7	1	BOARD ASSEMBLY, OFFSET GENERATOR	28480	08165-66512
A12C1	0160-0174	9		CAPACITOR-FXD .47UF +80-20% 25VDC CER	28480	0160-0174
A12C2	0140-0193	0		CAPACITOR-FXD 22PF +-5% 300VDC MICA	72136	DM15E820J0300*V1CR
A12C3	0160-4209	9		CAPACITOR-FXD .01UF +-20% 50VDC POLYE	28480	0160-4209
A12C4	0160-4209	9		CAPACITOR-FXD .01UF +-20% 50VDC POLYE	28480	0160-4209
A12C5	0140-0191	8	1	CAPACITOR-FXD 56PF +-5% 300VDC MICA	72136	DM15E560J0300*V1CR
A12C6	0140-0193	0		CAPACITOR-FXD 82PF +-5% 300VDC MICA	72136	DM15E820J0300*V1CR
A12C7	0160-4209	9		CAPACITOR-FXD .01UF +-20% 50VDC POLYE	28480	0160-4209
A12C8	0160-4209	9		CAPACITOR-FXD .01UF +-20% 50VDC POLYE	28480	0160-4209
A12C9	0160-2205	1	1	CAPACITOR-FXD 120PF +-5% 300VDC MICA	28480	0160-2205
A12C10	0180-0375	4		CAPACITOR-FXD 68UF+-10% 20VDC TA	56289	1500686X902082
A12C11	0160-4212	4		CAPACITOR-FXD .068UF +-20% 50VDC POLYE	28480	0160-4212
A12C12	0180-0375	4		CAPACITOR-FXD 68UF+-10% 20VDC TA	56289	1500686X902082
A12C13	0160-4212	4		CAPACITOR-FXD .068UF +-20% 50VDC POLYE	28480	0160-4212
A12CR1	1901-0044	5		DIODE-SWITCHING 50V 50MA 6NS	28480	1901-0044
A12CR2	1901-0044	5		DIODE-SWITCHING 50V 50MA 6NS	28480	1901-0044
A12CR3	1901-0044	5		DIODE-SWITCHING 50V 50MA 6NS	28480	1901-0044
A12CR4	1901-0044	5		DIODE-SWITCHING 50V 50MA 6NS	28480	1901-0044
A12CR5	1901-0044	5		DIODE-SWITCHING 50V 50MA 6NS	28480	1901-0044
A12CR6	1901-0044	5		DIODE-SWITCHING 50V 50MA 6NS	28480	1901-0044
A12F1	2110-0538	6	1	FUSE .5A 125V FAgT-BLO .281x.093	75915	276,500
A12K1	0490-1079	4		RELAY-REED 1A 500MA 100VDC 5VDC-COIL	28480	0490-1079
A12K2	0490-1079	4		RELAY-REED 1A 500MA 100VDC 5VDC-COIL	28480	0490-1079
A12L1	9140-0138	2	1	COIL-MLD 180UH 5% Q=65 .185DX.375LG-NOM	28480	9140-0138
A12MP1	1205-0033	6	2	HEAT SINK TO-5/TO-39-CS	28480	1205-0033
A12MP2	1205-0033	6		HEAT SINK TO-5/TO-39-CS	28480	1205-0033
A12Q1	1853-0036	2		TRANSISTOR PNP SI PD=310MW FT=250MHZ	28480	1853-0036
A12Q2	1854-0215	1		TRANSISTOR NPN SI PD=350MW FT=300MHZ	04713	2N3904
A12Q3	1855-0081	1		TRANSISTOR J-FET N-CHAN D-MODE SI	01295	2N5245
A12Q4	1853-0036	2		TRANSISTOR PNP SI PD=310MW FT=250MHZ	28480	1853-0036
A12Q5	1853-0036	2		TRANSISTOR PNP SI PD=310MW FT=250MHZ	28480	1853-0036
A12Q6	1854-0585	8	1	TRANSISTOR NPN SI PD=12.5W FT=50MHZ	04713	MJE182
A12Q7	1853-0400	4		TRANSISTOR PNP SI DARL TO-92 PD=500MW	28480	1853-0400
A12Q8	1853-0036	2		TRANSISTOR PNP SI PD=310MW FT=250MHZ	28480	1853-0036
A12Q9	1854-0215	1		TRANSISTOR NPN SI PD=350MW FT=300MHZ	04713	2N3904
A12Q10	1854-0215	1		TRANSISTOR NPN SI PD=350MW FT=300MHZ	04713	2N3904
A12Q11	1853-0341	2	1	TRANSISTOR PNP SI PD=12.5W FT=50MHZ	04713	MJE172
A12Q12	1854-0039	7	1	TRANSISTOR NPN 2N30538 SI TO-39 PD=1W	01928	2N30538
A12Q13	1853-0045	3	1	TRANSISTOR PNP SI TO-39 PD=5W FT=60MHZ	01928	2N4036
A12R1	0698-4125	7	2	RESISTOR 953 1% .125W F TC=0+-100	24546	C4-1/8-T0-953R-F
A12R2	0698-4411	4		RESISTOR 140 1% .125W F TC=0+-100	24546	C4-1/8-T0-140R-F
A12R3	0698-4453	4		RESISTOR 402 1% .125W F TC=0+-100	24546	C4-1/8-T0-402R-F
A12R4	2100-3349	2	1	RESISTOR-TMR 100 10% C STDE-ADJ 1-TRN	28480	2100-3349
A12R5	0757-0444	1		RESISTOR 12.1K 1% .125W F TC=0+-100	24546	C4-1/8-T0-1212-F

Table 6-3. Replaceable Parts (cont'd)

Reference Designation	HP Part Number	C D	Qty	Description	Mfr Code	Mfr Part Number
A12R6	0757-0444	1		RESISTOR 12,1K 1% .125W F TC0+-100	24546	C4-1/8-T0-1212-F
A12R7	0757-0444	1		RESISTOR 12,1K 1% .125W F TC0+-100	24546	C4-1/8-T0-1212-F
A12R8	0757-0444	1		RESISTOR 12,1K 1% .125W F TC0+-100	24546	C4-1/8-T0-1212-F
A12R9	0698-4541	1	1	RESISTOR 442K 1% .125W F TC0+-100	28480	0698-4541
A12R10	0683-3055	9	1	RESISTOR 3M 5% .25W FC TC=-900/+1100	01121	CB3055
A12R11	0698-4497	6	2	RESISTOR 48,7K 1% .125W F TC0+-100	24546	C4-1/8-T0-4872-F
A12R12	2100-3358	3		RESISTOR-TRMR 1M 20% C SIDE-ADJ 1-TRN	28480	2100-3358
A12R13	0683-3355	2	2	RESISTOR 3,3M 5% .25W FC TC=-900/+1100	01121	CB3355
A12R14	0757-0401	0		RESISTOR 100 1% .125W F TC0+-100	24546	C4-1/8-T0-101-F
A12R15	0698-4453	4		RESISTOR 402 1% .125W F TC0+-100	24546	C4-1/8-T0-402R-F
A12R16	0757-0346	2		RESISTOR 10 1% .125W F TC0+-100	24546	C4-1/8-T0-10R0-F
A12R17	0757-0988	8	2	RESISTOR 15 1% .5W F TC0+-100	28480	0757-0988
A12R18	0757-0411	2		RESISTOR 332 1% .125W F TC0+-100	24546	C4-1/8-T0-332R-F
A12R20	2100-3354	9		RESISTOR-TRMR 50K 10% C SIDE-ADJ 1-TRN	28480	2100-3354
A12R21	0698-5094	1		RESISTOR 5,1M 5% .25W FC TC=-900/+1100	01121	CB5155
A12R22	0683-1065	7		RESISTOR 10M 5% .25W FC TC=-900/+1100	01121	CB1065
A12R23	2100-3122	9		RESISTOR-TRMR 100 10% C SIDE-ADJ 17-TRN	02111	43P101
A12R24	0698-4125	7		RESISTOR 953 1% .125W F TC0+-100	24546	C4-1/8-T0-953R-F
A12R25	0757-0444	1		RESISTOR 12,1K 1% .125W F TC0+-100	24546	C4-1/8-T0-1212-F
A12R26	0757-0444	1		RESISTOR 12,1K 1% .125W F TC0+-100	24546	C4-1/8-T0-1212-F
A12R27	0757-0444	1		RESISTOR 12,1K 1% .125W F TC0+-100	24546	C4-1/8-T0-1212-F
A12R28	0698-4497	6		RESISTOR 48,7K 1% .125W F TC0+-100	24546	C4-1/8-T0-4872-F
A12R29	0757-0280	3		RESISTOR 1K 1% .125W F TC0+-100	24546	C4-1/8-T0-1001-F
A12R30	0683-3355	2		RESISTOR 3,3M 5% .25W FC TC=-900/+1100	01121	CB3355
A12R31	2100-3358	3		RESISTOR-TRMR 1M 20% C SIDE-ADJ 1-TRN	28480	2100-3358
A12R32	0757-0401	0		RESISTOR 100 1% .125W F TC0+-100	24546	C4-1/8-T0-101-F
A12R33	0698-4453	4		RESISTOR 402 1% .125W F TC0+-100	24546	C4-1/8-T0-402R-F
A12R34	0757-0346	2		RESISTOR 10 1% .125W F TC0+-100	24546	C4-1/8-T0-10R0-F
A12R35	0757-0988	8		RESISTOR 15 1% .5W F TC0+-100	28480	0757-0988
A12R36	0757-0411	2		RESISTOR 332 1% .125W F TC0+-100	24546	C4-1/8-T0-332R-F
A12R37	0757-0280	3		RESISTOR 1K 1% .125W F TC0+-100	24546	C4-1/8-T0-1001-F
A12R38	0757-0280	3		RESISTOR 1K 1% .125W F TC0+-100	24546	C4-1/8-T0-1001-F
A12R40	0698-3444	1		RESISTOR 316 1% .125W F TC0+-100	24546	C4-1/8-T0-316R-F
A12R41	0698-4433	0		RESISTOR 2,26K 1% .125W F TC0+-100	24546	C4-1/8-T0-2261-F
A12R43	0698-3444	1		RESISTOR 316 1% .125W F TC0+-100	24546	C4-1/8-T0-316R-F
A12R42	0698-4433	0		RESISTOR 2,26K 1% .125W F TC0+-100	24546	C4-1/8-T0-2261-F
A12U1	1820-1745	3		IC GATE CMOS NOR QUAD 2-INP	04713	MC14001BCP
A12U2	1826-0059	2		IC OP AMP GP TO-99	01295	LM201AL
A12U3	1826-0059	2		IC OP AMP GP TO-99	01295	LM201AL
A12U4	1826-0059	2		IC OP AMP GP TO-99	01295	LM201AL
A12VR1	1902-0025	4		DIODE-ZNR 10V 5% DO-7 PD=.4W TC=+.067x	28480	1902-0025
A12VR2	1902-3224	1	2	DIODE-ZNR 17.8V 5% DO-7 Pn=.4W TC=+.067x	28480	1902-3224
A12VR3	1902-3224	1		DIODE-ZNR 17.8V 5% DO-7 PD=.4W TC=+.067x	28480	1902-3224
A14	08165-66514	9	1	BOARD ASSEMBLY, HP-IB	28480	08165-66514
A14C1	0160-1715	8		CAPACITOR-FXD 150UF+-10% 6VDC TA	56289	150D157X9006R2
A14C2	0160-0174	9		CAPACITOR-FXD .47UF +80-20% 25VDC CER	28480	0160-0174
A14C3	0160-4209	9		C - FXD .01 UF 50 V 20%		
A14C4	0160-4209			C - FXD .01 UF 50 V 20%		
A14C5	0160-4209			C - FXD .01 UF 50 V 20%		
A14C6	0160-3455	5	1	CAPACITOR-FXD 470PF +-10% 1KVDC CER	28480	0160-3455
A14J1	1251-3283	1	1	CONNECTOR 24-PIN F MICROBTBSON	28480	1251-3283
A14J3	1200-0485	2	1	SOCKET-IC 14-CONT DIP DIP-SLDR	28480	1200-0485
A14MP1	0380-0643	3	1	STANDOFF-HEX .255-IN-LG 6-32TWD	00000	ORDER BY DESCRIPTION
A14MP2	08165-00205	7	1	PANEL, HIDDEN	28480	08165-00205
A14R1	1810-0136	3	2	NETWORK-RES 10-SIP MULTI-VALUE	28480	1810-0136
A14R2	1810-0136	3		NETWORK-RES 10-SIP MULTI-VALUE	28480	1810-0136
A14R3	0757-0442	9		RESISTOR 10K 1% .125W F TC0+-100	24546	C4-1/8-T0-1002-F
A14R4	0757-0442	9		RESISTOR 10K 1% .125W F TC0+-100	24546	C4-1/8-T0-1002-F
A14R5	0757-0442	9		RESISTOR 10K 1% .125W F TC0+-100	24546	C4-1/8-T0-1002-F
A14R6	0757-0442	9		RESISTOR 10K 1% .125W F TC0+-100	24546	C4-1/8-T0-1002-F
A14R7	0757-0442	9		RESISTOR 10K 1% .125W F TC0+-100	24546	C4-1/8-T0-1002-F
A14R8	0757-0442	9		RESISTOR 10K 1% .125W F TC0+-100	24546	C4-1/8-T0-1002-F
A14R9	0757-0407	6		RESISTOR 200 1% .125W F TC0+-100	24546	C4-1/8-T0-201-F
A14S1	3101-2159	1	1	SWITCH - SL 1A	28480	3101-1860
A14U1	1820-1481	4		IC NMOS	04713	MC6821L
A14U2	1820-1481	4		IC NMOS	04713	MC6821L
A14U3	1820-1624	7	1	IC BFR TTL 3 OCTL 1-INP	01295	SN748241N
A14U4	1820-1451	8		IC GATE TTL 3 NAND QUAD 2-INP	01295	SN74838N
A14U5	1820-1197	9		IC GATE TTL LS NAND QUAD 2-INP	01295	SN74LS00N
A14U6	1820-1416	5	2	IC SCHMITT-TRIG TTL LS INV HEX 1-INP	01295	SN74LS14N
A14U7	1820-1197	9		IC GATE TTL LS NAND QUAD 2-INP	01295	SN74LS00N
A14U8	1820-1208	3		IC GATE TTL LS OR QUAD 2-INP	01295	SN74LS32N
A14U9	1820-1416	5		IC SCHMITT-TRIG TTL LS INV HEX 1-INP	01295	SN74LS14N

Table 6-3. Replaceable Parts (cont'd)

Reference Designation	HP Part Number	C D	Qty	Description	Mfr Code	Mfr Part Number
A14K1	5081-1979	1	1	CABLE, RIBBON 279MM	28480	5081-1979
A15	08165-66515	0	1	BOARD ASSEMBLY, RAMP ADJUST	28480	08165-66515
A15R33	2100-3162	7	2	RESISTOR-TRMR 200K 10% C SIDE-ADJ 17-TRN	02111	43P204
A15R35	2100-3052	4	3	RESISTOR-TRMR 50 10% C SIDE-ADJ 17-TRN	02111	43P500
A15R37	2100-3052	4		RESISTOR-TRMR 50 10% C SIDE-ADJ 17-TRN	02111	43P500
A15R39	2100-3162	7		RESISTOR-TRMR 200K 10% C SIDE-ADJ 17-TRN	02111	43P204
A16	08165-66516	1	1	BOARD ASSEMBLY, SOURCES AD	28480	08165-66516
A16R240	2100-3161	6	1	RESISTOR-TRMR 20K 10% C SIDE-ADJ 17-TRN	02111	43P203
A16R243	2100-3103	6		RESISTOR-TRMR 10K 10% C SIDE-ADJ 17-TRN	02111	43P103
A16R250	2100-3103	6		RESISTOR-TRMR 10K 10% C SIDE-ADJ 17-TRN	02111	43P103
A16R430	2100-3103	6		RESISTOR-TRMR 10K 10% C SIDE-ADJ 17-TRN	02111	43P103
A17	08165-66517			BD ASSY-APT D ADJ		
A17R230	2100-3052	4		RESISTOR-TRMR 50 10% C SIDE-ADJ 17-TRN	02111	43P500
A17R340	2100-3154	7		RESISTOR-TRMR 1K 10% C SIDE-ADJ 17-TRN	02111	43P102
A17R360	2100-3109	2		RESISTOR-TRMR 2K 10% C SIDE-ADJ 17-TRN	02111	43P202

Table 6-3. Replaceable Parts (cont'd)

OPTIONS 002 and 003

Reference Designation	HP Part Number	C D	Qty	Description	Mfr Code	Mfr Part Number
A2	08165-66519	4	1	BOARD ASSEMBLY, DISPLAY	28480	08165-66519
A8	08165-66520	1	1	BD AY VCO CONTROL	28480	08165-66520
A11	08165-66511	6	1	BOARD ASSEMBLY, SWEEP GENERATOR	28480	08165-66511
A13	08165-66513	8	1	BOARD ASSEMBLY, AMPLITUDE MODULATION	28480	08165-66513
J6	1250-0118	3	1	CONNECTOR-RF BNC FEM SGL-HOLE-FR 50-OHM	28480	1250-0118
MP14	08165-28102	1	1	WINDOW	28480	08165-28102
W10	08165-61610	6	2	CABLE ASSEMBLY, AM OUTPUT	28480	08165-61610
W11	08165-61610	6		CABLE ASSEMBLY, AM OUTPUT	28480	08165-61610
CR407 (A8)	1901-0040	1		DIODE SWITCHING 30 V 50 MA 2 NS DO-35	28480	1901-0040
K403 (A8)	0490-1079	4	2	RELAY-REED 1 A 50 MA 100 VDC 5 VDC-COIL	28480	0490-1079
Q414 (A8)	1854-0215	1	2	TRANSISTOR NPN SI PD = 350 MW FT = 300 MHZ	04713	2N3904
R441 (A8)	0757-0439	4	2	RESISTOR 6.81K 1% .125 W F TC = 0 + - 100	24546	C4-1/8-TO-6811-F
R501 (A8)	0757-0442	9	2	RESISTOR 10 K 1% .125 W F TC = 0 + - 100	24546	C4-1/8-TO-1002-F
U607 (A8)	1820-1747	5	2	IC GATE CMOS NAND QUAD 2-INP	04713	MC14011BCP
MP7	08165-00207			PANEL FRONT (STD)		
MP8	08165-00208			PANEL SUB		
W14	08165-61614			CBL ASSY REAR EXT. INP. (OPT. 003)		
W15	08165-61615			CBL ASSY REAR SYNC. OUT (OPT. 003)		
W16	08165-61616			CBL ASSY REAR OUTP. (OPT. 003)		
MP9	08165-00209			PANEL FRONT (OPT. 002)		

Table 6-3. Replaceable Parts (cont'd)

Reference Designation	HP Part Number	C D	Qty	Description	Mfr Code	Mfr Part Number
A2	08165-66519	4	1	BOARD ASSEMBLY, DISPLAY	28480	08165-66519
A2C1	0160-0174	9	2	CAPACITOR-FXD .47UF +80-20% 25VDC CER	28480	0160-0174
A2C2	0160-0174	9		CAPACITOR-FXD .47UF +80-20% 25VDC CER	28480	0160-0174
A2C3	0180-1704	5	2	CAPACITOR-FXD 47UF+-10% 6VDC TA	56289	150D476X900682
A2C4	0180-1704	5		CAPACITOR-FXD 47UF+-10% 6VDC TA	56289	150D476X900682
A2DS1	1990-0487	7	31	LED-VISIBLE LUM=INT=IMCD IF=20MA=MAX	28480	5082-4584
A2DS2	1990-0487	7		LED-VISIBLE LUM=INT=IMCD IF=20MA=MAX	28480	5082-4584
A2DS3	1990-0487	7		LED-VISIBLE LUM=INT=IMCD IF=20MA=MAX	28480	5082-4584
A2DS4	1990-0487	7		LED-VISIBLE LUM=INT=IMCD IF=20MA=MAX	28480	5082-4584
A2DS5	1990-0487	7		LED-VISIBLE LUM=INT=IMCD IF=20MA=MAX	28480	5082-4584
A2DS6	1990-0487	7		LED-VISIBLE LUM=INT=IMCD IF=20MA=MAX	28480	5082-4584
A2DS7	1990-0487	7		LED-VISIBLE LUM=INT=IMCD IF=20MA=MAX	28480	5082-4584
A2DS8 to 31	1990-0670	7		LED VISIBLE YEL	28480	5082-4584
A2DS32	1990-0485	5	1	LED-VISIBLE LUM=INT=600UCD IF=30MA=MAX	28480	5082-4984
A2DS33	2140-0016	8	11	LAMP=INCAND 683 5VDC 60MA T=1-BULB	0000J	683
A2DS34	2140-0016	8		LAMP=INCAND 683 5VDC 60MA T=1-BULB	0000J	683
A2DS35	2140-0016	8		LAMP=INCAND 683 5VDC 60MA T=1-BULB	0000J	683
A2DS36	2140-0016	8		LAMP=INCAND 683 5VDC 60MA T=1-BULB	0000J	683
A2DS37	2140-0016	8		LAMP=INCAND 683 5VDC 60MA T=1-BULB	0000J	683
A2DS38	2140-0016	8		LAMP=INCAND 683 5VDC 60MA T=1-BULB	0000J	683
A2DS39	2140-0016	8		LAMP=INCAND 683 5VDC 60MA T=1-BULB	0000J	683
A2DS40	2140-0016	8		LAMP=INCAND 683 5VDC 60MA T=1-BULB	0000J	683
A2DS41	2140-0016	8		LAMP=INCAND 683 5VDC 60MA T=1-BULB	0000J	683
A2DS42	2140-0016	8		LAMP=INCAND 683 5VDC 60MA T=1-BULB	0000J	683
A2DS43	2140-0016	8		LAMP=INCAND 683 5VDC 60MA T=1-BULB	0000J	683
A2DS51	1990-0452	6	12	DISPLAY-NUM=SEG 1-CHAR .3-H	28480	5082-7731, CAT C-E
A2DS52	1990-0452	6		DISPLAY-NUM=SEG 1-CHAR .3-H	28480	5082-7731, CAT C-E
A2DS53	1990-0452	6		DISPLAY-NUM=SEG 1-CHAR .3-H	28480	5082-7731, CAT C-E
A2DS54	1990-0452	6		DISPLAY-NUM=SEG 1-CHAR .3-H	28480	5082-7731, CAT C-E
A2DS55	1990-0452	6		DISPLAY-NUM=SEG 1-CHAR .3-H	28480	5082-7731, CAT C-E
A2DS56	1990-0452	6		DISPLAY-NUM=SEG 1-CHAR .3-H	28480	5082-7731, CAT C-E
A2DS57	1990-0452	6		DISPLAY-NUM=SEG 1-CHAR .3-H	28480	5082-7731, CAT C-E
A2DS58	1990-0452	6		DISPLAY-NUM=SEG 1-CHAR .3-H	28480	5082-7731, CAT C-E
A2DS59	1990-0452	6		DISPLAY-NUM=SEG 1-CHAR .3-H	28480	5082-7731, CAT C-E
A2DS60	1990-0452	6		DISPLAY-NUM=SEG 1-CHAR .3-H	28480	5082-7731, CAT C-E
A2DS61	1990-0452	6		DISPLAY-NUM=SEG 1-CHAR .3-H	28480	5082-7731, CAT C-E
A2DS62	1990-0452	6		DISPLAY-NUM=SEG 1-CHAR .3-H	28480	5082-7731, CAT C-E
	1200-0589	7	12	SOCKET-IC 14-CONT DIP-SLDR	28480	1200-0589
	1200-0589	7		SOCKET-IC 14-CONT DIP-SLDR	28480	1200-0589
	1200-0589	7		SOCKET-IC 14-CONT DIP-SLDR	28480	1200-0589
	1200-0589	7		SOCKET-IC 14-CONT DIP-SLDR	28480	1200-0589
A2J8	1200-0589	7		SOCKET-IC 14-CONT DIP-SLDR	28480	1200-0589
A2J9	1200-0589	7		SOCKET-IC 14-CONT DIP-SLDR	28480	1200-0589
A2J10	1200-0589	7		SOCKET-IC 14-CONT DIP-SLDR	28480	1200-0589
A2J11	1200-0589	7		SOCKET-IC 14-CONT DIP-SLDR	28480	1200-0589
A2J12	1200-0589	7		SOCKET-IC 14-CONT DIP-SLDR	28480	1200-0589
A2J13	1200-0589	7		SOCKET-IC 14-CONT DIP-SLDR	28480	1200-0589
A2J14	1200-0589	7		SOCKET-IC 14-CONT DIP-SLDR	28480	1200-0589
A2J15	1200-0589	7		SOCKET-IC 14-CONT DIP-SLDR	28480	1200-0589

Table 6-3. Replaceable Parts (cont'd)

Reference Designation	HP Part Number	C D	Qty	Description	Mfr Code	Mfr Part Number
A201	1A54-0215	1	4	TRANSISTOR NPN 8I PD=350mw FT=300MHZ	04713	2N3904
A202	1A54-0215	1		TRANSISTOR NPN 8I PD=350mw FT=300MHZ	04713	2N3904
A203	1A54-0215	1		TRANSISTOR NPN 8I PD=350mw FT=300MHZ	04713	2N3904
A204	1A54-0215	1		TRANSISTOR NPN 8I PD=350mw FT=300MHZ	04713	2N3904
A205	1A54-0477	7	2	TRANSISTOR NPN 2N2222A 8I TO-18 PD=500mw	04713	2N2222A
A206	1A54-0477	7		TRANSISTOR NPN 2N2222A 8I TO-18 PD=500mw	04713	2N2222A
A2R1	0757-0706	8	4	RESISTOR 51.1 1% .25W F TC=0+-100	24546	C5-1/4-T0-S1R1-F
A2R2	0757-0706	8		RESISTOR 51.1 1% .25W F TC=0+-100	24546	C5-1/4-T0-S1R1-F
A2R3	0757-0706	8		RESISTOR 51.1 1% .25W F TC=0+-100	24546	C5-1/4-T0-S1R1-F
A2R4	0757-0706	8		RESISTOR 51.1 1% .25W F TC=0+-100	24546	C5-1/4-T0-S1R1-F
A2R5	0757-0280	3	6	RESISTOR 1K 1% .125W F TC=0+-100	24546	C4-1/8-T0-1001-F
A2R6	0757-0280	3		RESISTOR 1K 1% .125W F TC=0+-100	24546	C4-1/8-T0-1001-F
A2R7	0757-0280	3		RESISTOR 1K 1% .125W F TC=0+-100	24546	C4-1/8-T0-1001-F
A2R8	0757-0280	3		RESISTOR 1K 1% .125W F TC=0+-100	24546	C4-1/8-T0-1001-F
A2R9	0757-0280	3		RESISTOR 1K 1% .125W F TC=0+-100	24546	C4-1/8-T0-1001-F
A2R10	0757-0280	3		RESISTOR 1K 1% .125W F TC=0+-100	24546	C4-1/8-T0-1001-F
A2R11	0757-0281	4	4	RESISTOR 2.74K 1% .125W F TC=0+-100	24546	C4-1/8-T0-2741-F
A2R12	0757-0281	4		RESISTOR 2.74K 1% .125W F TC=0+-100	24546	C4-1/8-T0-2741-F
A2R13	0757-0281	4		RESISTOR 2.74K 1% .125W F TC=0+-100	24546	C4-1/8-T0-2741-F
A2R14	0757-0281	4		RESISTOR 2.74K 1% .125W F TC=0+-100	24546	C4-1/8-T0-2741-F
A2R15	0698-3155	1	2	RESISTOR 4.64K 1% .125W F TC=0+-100	24546	C4-1/8-T0-4641-F
A2R16	0698-3155	1		RESISTOR 4.64K 1% .125W F TC=0+-100	24546	C4-1/8-T0-4641-F
A2R17	0757-0417	8	1	RESISTOR 562 1% .125W F TC=0+-100	24546	C4-1/8-T0-562R-F
A2R18	1810-0162	5	1	NETWORK-RES 14-DIP4,7K OHM X 13	11236	760-1-R0,7K
A2R19	8159-0005	0	3	WIRE 22AWG W PVC 1X22 80C	28480	8159-0005
A2R20	8159-0005	0		WIRE 22AWG W PVC 1X22 80C	28480	8159-0005
A2R21	8159-0005	0		WIRE 22AWG W PVC 1X22 80C	28480	8159-0005
A281	5060-9436	7	26	PUSHBUTTON SWITCH P.C. MOUNT	28480	5060-9436
A282	5060-9436	7		PUSHBUTTON SWITCH P.C. MOUNT	28480	5060-9436
A283	5060-9436	7		PUSHBUTTON SWITCH P.C. MOUNT	28480	5060-9436
A284	5060-9436	7		PUSHBUTTON SWITCH P.C. MOUNT	28480	5060-9436
A285	5060-9436	7		PUSHBUTTON SWITCH P.C. MOUNT	28480	5060-9436
A286	5060-9436	7		PUSHBUTTON SWITCH P.C. MOUNT	28480	5060-9436
A287	5060-9436	7		PUSHBUTTON SWITCH P.C. MOUNT	28480	5060-9436
A288	5060-9436	7		PUSHBUTTON SWITCH P.C. MOUNT	28480	5060-9436
A289	5060-9436	7		PUSHBUTTON SWITCH P.C. MOUNT	28480	5060-9436
A2810	5060-9436	7		PUSHBUTTON SWITCH P.C. MOUNT	28480	5060-9436
A2811	5060-9436	7		PUSHBUTTON SWITCH P.C. MOUNT	28480	5060-9436
A2812	5060-9436	7		PUSHBUTTON SWITCH P.C. MOUNT	28480	5060-9436
A2813	5060-9436	7		PUSHBUTTON SWITCH P.C. MOUNT	28480	5060-9436
A2814	5060-9436	7		PUSHBUTTON SWITCH P.C. MOUNT	28480	5060-9436
A2815	5060-9436	7		PUSHBUTTON SWITCH P.C. MOUNT	28480	5060-9436
A2816	5060-9436	7		PUSHBUTTON SWITCH P.C. MOUNT	28480	5060-9436
A2817	5060-9436	7		PUSHBUTTON SWITCH P.C. MOUNT	28480	5060-9436
A2818	5060-9436	7		PUSHBUTTON SWITCH P.C. MOUNT	28480	5060-9436
A2819	5060-9436	7		PUSHBUTTON SWITCH P.C. MOUNT	28480	5060-9436
A2820	5060-9436	7		PUSHBUTTON SWITCH P.C. MOUNT	28480	5060-9436
A2821	5060-9436	7		PUSHBUTTON SWITCH P.C. MOUNT	28480	5060-9436
A2822	5060-9436	7		PUSHBUTTON SWITCH P.C. MOUNT	28480	5060-9436
A2823	5060-9436	7		PUSHBUTTON SWITCH P.C. MOUNT	28480	5060-9436
A2824	5060-9436	7		PUSHBUTTON SWITCH P.C. MOUNT	28480	5060-9436
A2825	5060-9436	7		PUSHBUTTON SWITCH P.C. MOUNT	28480	5060-9436
A2826	5060-9436	7		PUSHBUTTON SWITCH P.C. MOUNT	28480	5060-9436
A2U1	1820-1200	5	1	IC INV TTL LS HEX	01295	8N74LS05N
A2U2	1820-0628	9	1	IC TTL 64-BIT RAM 60-NS 0=C	01295	8N7489N
A2U3	1820-0491	4	1	IC ODDR TTL BCD-TO-DEC 4-TO-10=LINE	01295	8N74145N
A2W1	5081-1980	4	2	CABLE, RIBBON 279MM	28480	5081-1980
A2W2	5081-1980	4		CABLE, RIBBON 279MM	28480	5081-1980
A2W3	5081-1981	5	1	CABLE, RIBBON 26C 305MM	28480	5081-1981

Table 6-3. Replaceable Parts (cont'd)

Reference Designation	HP Part Number	C D	Qty	Description	Mfr Code	Mfr Part Number
A11	08165-66511	6	1	BOARD ASSEMBLY, SWEEP GENERATOR	28480	08165-66511
A11C101	0160-4211	3	5	CAPACITOR-FXD .047UF +-20% 50VDC POLYE	28480	0160-4211
A11C201	0160-4209	9	2	CAPACITOR-FXD .01UF +-20% 50VDC POLYE	28480	0160-4209
A11C202	0160-0598	1	1	CAPACITOR-FXD 2200PF +-10% 250VDC	28480	0160-0598
A11C203	0160-4211	3	3	CAPACITOR-FXD .047UF +-20% 50VDC POLYE	28480	0160-4211
A11C401	0160-0116	1	2	CAPACITOR-FXD 6.8UF+-10% 35VDC TA	56289	150D665X9035B2
A11C402	0160-0116	1	1	CAPACITOR-FXD 6.8UF+-10% 35VDC TA	56289	150D665X9035B2
A11C403	0160-4211	3	3	CAPACITOR-FXD .047UF +-20% 50VDC POLYE	28480	0160-4211
A11C404	0160-4211	3	3	CAPACITOR-FXD .047UF +-20% 50VDC POLYE	28480	0160-4211
A11C405	0160-1704	5	5	CAPACITOR-FXD 47UF+-10% 6VDC TA	56289	150D476X9006B2
A11C406	0160-4298	6	1	CAPACITOR-FXD 4700PF +-20% 250VDC CER	56289	C067F251H47M322-CDH
A11C407*	0160-4365	1	1	CAPACITOR-FXD 470PF +-5% 300VDC MICA	28480	0160-4365
A11C408	0160-5374	3	3	CAPACITOR-FXD .047UF 50VDC	28480	0160-5374
A11C409	0140-0193	0	1	CAPACITOR-FXD 82PF +-5% 300VDC MICA	72136	DM15E820J0300HVICR
A11C410	0160-4209	9	9	CAPACITOR-FXD .01UF +-20% 50VDC POLYE	28480	0160-4209
A11C411	0160-0576	1	1	CAPACITOR-FXD .1UF +-20% 50VDC CER	28480	0160-0576
A11C412	0160-0576	1	1	CAPACITOR-FXD .1UF +-20% 50VDC CER	28480	0160-0576
A11CR401	1901-0044	5	2	DIODE-SWITCHING 50V 50MA 6NS	28480	1901-0044
A11CR402	1901-0044	5	5	DIODE-SWITCHING 50V 50MA 6NS	28480	1901-0044
A11CR403	1901-0460	9	2	DIODE-STABILISOR 30V 150MA DO-7	28480	1901-0460
A11CR404	1901-0460	9	2	DIODE-STABILISOR 30V 150MA DO-7	28480	1901-0460
A11CR405	1901-0460	9	2	DIODE-STABILISOR 30V 150MA DO-7	28480	1901-0460
A11Q101	1854-0215	1	3	TRANSISTOR NPN SI PD=350MW FT=300MHZ	04713	2N3904
A11Q102	1854-0215	1	1	TRANSISTOR NPN SI PD=350MW FT=300MHZ	04713	2N3904
A11Q401	1854-0215	1	1	TRANSISTOR NPN SI PD=350MW FT=300MHZ	04713	2N3904
A11Q402	1853-0036	2	2	TRANSISTOR PNP SI PD=310MW FT=250MHZ	28480	1853-0036
A11Q403	1853-0036	2	2	TRANSISTOR PNP SI PD=310MW FT=250MHZ	28480	1853-0036
A11R101	0757-0442	9	3	RESISTOR 10K 1% .125W F TC=0+-100	24546	C4-1/8-T0=1002-F
A11R102	0698-4444	3	3	RESISTOR 4.87K 1% .125W F TC=0+-100	24546	C4-1/8-T0=4871-F
A11R103	0757-0349	5	1	RESISTOR 22.6K 1% .125W F TC=0+-100	24546	C4-1/8-T0=2262-F
A11R201	0757-0280	3	4	RESISTOR 1K 1% .125W F TC=0+-100	24546	C4-1/8-T0=1001-F
A11R202	0757-0440	7	1	RESISTOR 7.5K 1% .125W F TC=0+-100	24546	C4-1/8-T0=7501-F
A11R203	2100-3273	1	1	RESISTOR-TRMR 2K 10% C SIDE-ADJ 1-TRN	28480	2100-3273
A11R401	0698-4435	2	2	RESISTOR 2.49K 1% .125W F TC=0+-100	24546	C4-1/8-T0=2491-F
A11R402	0698-4435	2	1	RESISTOR 2.49K 1% .125W F TC=0+-100	24546	C4-1/8-T0=2491-F
A11R403	0698-3700	2	1	RESISTOR 715 1% .125W F TC=0+-100	24546	C4-1/8-T0=715R-F
A11R404	2100-3122	9	1	RESISTOR-TRMR 100 10% C SIDE-ADJ 17-TRN	02111	43P101
A11R405	0757-0442	9	9	RESISTOR 10K 1% .125W F TC=0+-100	24546	C4-1/8-T0=1002-F
A11R406	0757-0442	9	9	RESISTOR 10K 1% .125W F TC=0+-100	24546	C4-1/8-T0=1002-F
A11R407	0757-0280	3	3	RESISTOR 1K 1% .125W F TC=0+-100	24546	C4-1/8-T0=1001-F
A11R408	0757-0419	0	3	RESISTOR 681 1% .125W F TC=0+-100	24546	C4-1/8-T0=681R-F
A11R409	0757-0438	3	1	RESISTOR 5.11K 1% .125W F TC=0+-100	24546	C4-1/8-T0=5111-F
A11R410	2100-3351	6	1	RESISTOR-TRMR 500 10% C SIDE-ADJ 1-TRN	28480	2100-3351
A11R411	0698-4043	8	1	RESISTOR 1.96K 1% .125W F TC=0+-100	24546	C4-1/8-T0=1961-F
A11R420	0757-0442	1	1	RESISTOR 10K 1% .125W F TC=0+-100	24546	C4-1/8-T0=1002-F
A11R421	0698-0465	1	1	RESISTOR 100K 1% .125W F TC=0+-100	24546	C4-1/8-T0=1003-F
A11R422	0683-0419	1	1	RESISTOR 681 1% .125W F TC=0+-100	01121	C4-1/8-T0=681R-F
A11R423	2100-3154	1	1	RESISTOR-TRMR 1K 10% C SIDE-ADJ 17-TRN	02111	43P102
A11R424	0757-0460	1	1	RESISTOR 61.9 1% .125W		
A11R425	0698-4961	1	1	RESISTOR 90.6K 1% .125W		
A11R426	2100-3162	1	1	RESISTOR-TRMR 200K 10% C SIDE-ADJ 17-TRN	02111	43P204
A11R429	0757-0281	1	1	RESISTOR 2.74K 1% .125W F TC=0+-100	24546	C4-1/8-T0=2741-F
A11R430	0757-0444	1	1	RESISTOR 12.1K 1% .125W F TC=0+-100	24546	C4-1/8-T0=1212-F
A11R431	0698-6447	1	1	RESISTOR 683.81K 1% .15W F TC=0+-100	24546	C4-1/8-T0=687R-F
A11R432*	0757-0200	1	1	RESISTOR 5.62K 1% .125W F TC=0+-100	24546	C4-1/8-T0=5621-F
A11R433	2100-3103	1	1	RESISTOR-TRMR 10K 10% C SIDE-ADJ 17-TRN	02111	43P103
A11R434	0683-0655	1	1	RESISTOR 6.8M 5% .125W		
A11R440	0757-0280	3	1	RESISTOR 1K 1% .125W F TC=0+-100	24546	C4-1/8-T0=1001-F
A11R441	0757-0280	3	1	RESISTOR 1K 1% .125W F TC=0+-100	24546	C4-1/8-T0=1001-F
A11RT1	0637-0035	1	1	TEMPERISTOR DISC 5K=0MW TC=+0.4%/C-DEG		
A11U101	1820-1956	8	5	IC LCH CMOS COM CLOCK QUAD	01928	CD40428E
A11U102	1820-1956	8	5	IC LCH CMOS COM CLOCK QUAD	01928	CD40428E
A11U103	1820-1956	8	5	IC LCH CMOS COM CLOCK QUAD	01928	CD40428E
A11U104	1820-1956	8	5	IC LCH CMOS COM CLOCK QUAD	01928	CD40428E
A11U105	1820-1956	8	5	IC LCH CMOS COM CLOCK QUAD	01928	CD40428E
A11U106	1820-1963	7	3	IC FF CMOS D-TYPE POS-EDGE-TRIG DUAL	01928	CD40138AE
A11U107	1820-1963	7	3	IC FF CMOS D-TYPE POS-EDGE-TRIG DUAL	01928	CD40138AE
A11U108	1820-1963	7	3	IC FF CMOS D-TYPE POS-EDGE-TRIG DUAL	01928	CD40138AE
A11U109	1820-1965	9	1	IC GATE CMOS NOR TPL 3-INP	04713	MC14025BCP
A11U110	1820-1970	6	1	IC GATE CMOS OR QUAD 2-INP	04713	MC14071BCP
A11U111	1820-0629	0	1	IC FF TTL S J-K NEG-EDGE-TRIG	01295	SN748112N
A11U112	1820-1964	8	2	IC FF CMOS J-K POS-EDGE-TRIG DUAL	01928	CD4027BE
A11U113	1820-1961	5	1	IC GATE CMOS NAND TPL 3-INP	04713	MC14023BCP
A11U114	1820-1747	5	1	IC GATE CMOS NAND QUAD 2-INP	04713	MC14011BCP
A11U201	1826-0180	0	1	IC TIMER TTL MONO/ASTBL	04713	MC1455P1

Table 6-3. Replaceable Parts (cont'd)

Reference Designation	HP Part Number	C D	Qty	Description	Mfr Code	Mfr Part Number
A11U202	1820-1241	4	1	IC MUXR/DATA-8EL CMOS 8-TO-1-LINE 8-INP	04713	MC14512CP
A11U203	1820-1122	0	3	IC CNTR CMOS BCD SYNCHRO DUAL	04713	MC14518BCP
A11U204	1820-1122	0		IC CNTR CMOS BCD SYNCHRO DUAL	04713	MC14518BCP
A11U205	1820-1122	0		IC CNTR CMOS BCD SYNCHRO DUAL	04713	MC14518BCP
A11U301	1820-1964	8		IC FF CMOS J-K POS-EDGE-TRIG DUAL	01928	CD4027BE
A11U302	1820-1114	0	2	IC CNTR CMOS BIN SYNCHRO POS-EDGE-TRIG	04713	MC14516CP
A11U303	1820-1114	0		IC CNTR CMOS BIN SYNCHRO POS-EDGE-TRIG	04713	MC14516CP
A11U304	1820-0603			IC		
A11U305	1820-0603			IC		
A11U306	1820-0603			IC		
A11U307	1820-0603			IC		
A11U308	1820-2015	2	1	IC GATE CMOS EXCL-OR QUAD	04713	MC14070BCP
A11U309	1820-2037	8	1	IC GATE CMOS AND QUAD 2-INP	04713	MC14081BCP
A11U401	1826-0462	1	1	IC CONV 10-B-D/A 16-DIP-C	04713	MC3410CL
A11U402	1826-0111	7	1	IC OP AMP GP DUAL TO-99	04713	MC1458G
A11U403	1826-0543	5	1	IC		
A11U404	1826-0543			IC		
A11VR401	1902-0184	6	2	DIODE-ZNR 16.2V 5% DO-7 PDS,4W TC=+.066%	28480	1902-0184
A11VR402	1902-0184	6		DIODE-ZNR 16.2V 5% DO-7 PDS,4W TC=+.066%	28480	1902-0184
A11VR403	1902-0041	4	2	DIODE-ZNR 5.11V 5% DO-7 PDS,4W TC=-.009%	28480	1902-0041
A11VR404	1902-0041	4		DIODE-ZNR 5.11V 5% DO-7 PDS,4W TC=-.009%	28480	1902-0041

Table 6-3. Replaceable Parts (cont'd)

Reference Designation	HP Part Number	C D	Qty	Description	Mfr Code	Mfr Part Number
A13	08165-66513 08165-26513	8 4	1 1	BOARD ASSEMBLY, AMPLITUDE MODULATION PC BOARD, BLANK	28480 28480	08165-66513 08165-26513
A13C1	0160-1746	5	2	CAPACITOR-FXD 15UF+-10% 20VDC TA	56289	150D156X902082
A13C2	0160-1746	5	2	CAPACITOR-FXD 15UF+-10% 20VDC TA	56289	150D156X902082
A13C3	0160-0174	9	5	CAPACITOR-FXD .47UF +80-20% 25VDC CER	28480	0160-0174
A13C4	0160-0174	9	5	CAPACITOR-FXD .47UF +80-20% 25VDC CER	28480	0160-0174
A13C5	0160-3508	9	5	CAPACITOR-FXD 1UF +80-20% 50VDC CER	28480	0160-3508
A13C6	0160-0174	9	5	CAPACITOR-FXD .47UF +80-20% 25VDC CER	28480	0160-0174
A13C7	0160-3879	7	5	CAPACITOR-FXD .01UF +-20% 100VDC CER	28480	0160-3879
A13C8	0160-3879	7	5	CAPACITOR-FXD .01UF +-20% 100VDC CER	28480	0160-3879
A13C100	0160-4209	9	1	CAPACITOR-FXD .01UF +-20% 50VDC POLYE	28480	0160-4209
A13C300	0160-0174	9	5	CAPACITOR-FXD .47UF +80-20% 25VDC CER	28480	0160-0174
A13C301	0160-3879	7	5	CAPACITOR-FXD .01UF +-20% 100VDC CER	28480	0160-3879
A13C302	0160-0576	5	1	CAPACITOR-FXD .1UF +-20% 50VDC CER	28480	0160-0576
A13C303	0160-3879	7	5	CAPACITOR-FXD .01UF +-20% 100VDC CER	28480	0160-3879
A13C304	0160-3879	7	5	CAPACITOR-FXD .01UF +-20% 100VDC CER	28480	0160-3879
A13CR1	1901-0040	1	5	DIODE-SWITCHING 30V 50MA 2NS DO-35	28480	1901-0040
A13CR2	1901-0050	3	2	DIODE-SWITCHING 80V 200MA 2NS DO-35	28480	1901-0050
A13CR100	1901-0460	9	2	DIODE-STARBIATOR 30V 150MA DO-7	28480	1901-0460
A13CR101	1901-0040	1	5	DIODE-SWITCHING 30V 50MA 2NS DO-35	28480	1901-0040
A13CR102	1901-0460	9	2	DIODE-STARBIATOR 30V 150MA DO-7	28480	1901-0460
A13CR103	1901-0040	1	5	DIODE-SWITCHING 30V 50MA 2NS DO-35	28480	1901-0040
A13CR104	1901-0040	1	5	DIODE-SWITCHING 30V 50MA 2NS DO-35	28480	1901-0040
A13CR105	1901-0050	3	2	DIODE-SWITCHING 80V 200MA 2NS DO-35	28480	1901-0050
A13CR106	1901-0040	1	5	DIODE-SWITCHING 30V 50MA 2NS DO-35	28480	1901-0040
A13K1	0490-1034	1	2	RELAY 2C 12VDC-COIL .5A 350VDC	28480	0490-1034
A13K2	0490-1034	1	2	RELAY 2C 12VDC-COIL .5A 350VDC	28480	0490-1034
A13K3	0490-1079	4	1	RELAY-REED 1A 500MA 100VDC 5VDC-COIL	28480	0490-1079
A13MP1	01801-22301	7	1	HEAT SINK	28480	01801-22301
A13Q1	1854-0215	1	7	TRANSISTOR NPN SI PD=350MW FT=300MHZ	04713	2N3904
A13Q2	1853-0036	2	3	TRANSISTOR PNP SI PD=310MW FT=250MHZ	28480	1853-0036
A13Q3	1854-0215	1	7	TRANSISTOR NPN SI PD=350MW FT=300MHZ	04713	2N3904
A13Q4	1854-0215	1	7	TRANSISTOR NPN SI PD=350MW FT=300MHZ	04713	2N3904
A13Q5	1853-0086	2	3	TRANSISTOR PNP SI PD=310MW FT=40MHZ	27014	2N5087
A13Q6	1853-0036	2	3	TRANSISTOR PNP SI PD=310MW FT=250MHZ	28480	1853-0036
A13Q7	1853-0036	2	3	TRANSISTOR PNP SI PD=310MW FT=250MHZ	28480	1853-0036
A13Q100	1854-0392	5	2	TRANSISTOR NPN SI PD=310MW FT=50MHZ	04713	2N5088
A13Q101	1854-0392	5	2	TRANSISTOR NPN SI PD=310MW FT=50MHZ	04713	2N5088
A13Q102	1854-0215	1	7	TRANSISTOR NPN SI PD=350MW FT=300MHZ	04713	2N3904
A13Q103	1854-0215	1	7	TRANSISTOR NPN SI PD=350MW FT=300MHZ	04713	2N3904
A13Q104	1854-0215	1	7	TRANSISTOR NPN SI PD=350MW FT=300MHZ	04713	2N3904
A13Q105	1853-0086	2	3	TRANSISTOR PNP SI PD=310MW FT=40MHZ	27014	2N5087
A13Q106	1853-0086	2	3	TRANSISTOR PNP SI PD=310MW FT=40MHZ	27014	2N5087
A13Q200	1854-0215	1	7	TRANSISTOR NPN SI PD=350MW FT=300MHZ	04713	2N3904
A13Q301	1853-0218	2	2	TRANSISTOR PNP SI TO-18 PD=360MW	28480	1853-0218
A13Q302	1853-0218	2	2	TRANSISTOR PNP SI TO-18 PD=360MW	28480	1853-0218
A13Q303	1854-0354	9	2	TRANSISTOR NPN SI TO-52 PD=360MW	28480	1854-0354
A13Q304	1854-0354	9	2	TRANSISTOR NPN SI TO-52 PD=360MW	28480	1854-0354
A13Q305	1854-0637	1	1	TRANSISTOR NPN 2N2219A SI TO-5 PD=800MW	01295	2N2219A
A13R1	0757-0438	3	1	RESISTOR 5.1K 1% .125W F TC=0+-100	24546	C4-1/8-T0-5111-F
A13R2	0757-0439	3	1	RESISTOR 6.81K 1% .125W F TC=0+-100	24546	C4-1/8-T0-6811-F
A13R3	0757-0290	3	5	RESISTOR 1K 1% .125W F TC=0+-100	24546	C4-1/8-T0-1001-F
A13R4	0757-0349	5	5	RESISTOR 22.6K 1% .125W F TC=0+-100	24546	C4-1/8-T0-2262-F
A13R5	0757-0349	5	5	RESISTOR 22.6K 1% .125W F TC=0+-100	24546	C4-1/8-T0-2262-F
A13R6	0757-0349	5	5	RESISTOR 22.6K 1% .125W F TC=0+-100	24546	C4-1/8-T0-2262-F
A13R7	0698-4425	0	5	RESISTOR 1.54K 1% .125W F TC=0+-100	24546	C4-1/8-T0-1541-F
A13R8	0757-0123	3	1	RESISTOR 34.8K 1% .125W F TC=0+-100	28480	0757-0123
A13R10	0757-0433	8	1	RESISTOR 3.32K 1% .125W F TC=0+-100	24546	C4-1/8-T0-3321-F
A13R11	0698-4425	0	5	RESISTOR 1.54K 1% .125W F TC=0+-100	24546	C4-1/8-T0-1541-F
A13R12	0757-0401	0	9	RESISTOR 100 1% .125W F TC=0+-100	24546	C4-1/8-T0-101-F
A13R13	0698-4421	6	3	RESISTOR 249 1% .125W F TC=0+-100	24546	C4-1/8-T0-249R-F
A13R14	0757-0401	0	9	RESISTOR 100 1% .125W F TC=0+-100	24546	C4-1/8-T0-101-F
A13R15	0757-0422	5	2	RESISTOR 909 1% .125W F TC=0+-100	24546	C4-1/8-T0-909R-F
A13R100	0757-0338	2	1	RESISTOR 1K 1% .25W F TC=0+-100	24546	C5-1/4-T0-1001-F
A13R101	0698-1055	5	1	RESISTOR 1M 5% .25W FC TC=800/+900	01121	CR1055
A13R102	2100-3358	3	1	RESISTOR-TRMR 1W 20X C SIDE=ADJ 1-TRN	28480	2100-3358
A13R103	0757-0442	9	2	RESISTOR 10K 1% .125W F TC=0+-100	24546	C4-1/8-T0-1002-F
A13R104	0698-4421	6	3	RESISTOR 249 1% .125W F TC=0+-100	24546	C4-1/8-T0-249R-F
A13R105	0698-4421	6	3	RESISTOR 249 1% .125W F TC=0+-100	24546	C4-1/8-T0-249R-F
A13R106	0698-0082	7	2	RESISTOR 464 1% .125W F TC=0+-100	24546	C4-1/8-T0-4640-F
A13R107	0698-0082	7	2	RESISTOR 464 1% .125W F TC=0+-100	24546	C4-1/8-T0-4640-F
A13R108	0698-4435	2	6	RESISTOR 2.49K 1% .125W F TC=0+-100	24546	C4-1/8-T0-2491-F
A13R109	0698-4435	2	6	RESISTOR 2.49K 1% .125W F TC=0+-100	24546	C4-1/8-T0-2491-F
A13R110	0757-0416	7	2	RESISTOR 511 1% .125W F TC=0+-100	24546	C4-1/8-T0-511R-F

Table 6-3. Replaceable Parts (cont'd)

Reference Designation	HP Part Number	C D	Qty	Description	Mfr Code	Mfr Part Number
A13R111	0698-4469	2	1	RESISTOR 1.15K 1% .125W F TC0+100	24546	C4-1/8-T0=1151-F
A13R112	0757-0442	9		RESISTOR 10K 1% .125W F TC0+100	24546	C4-1/8-T0=1002-F
A13R120	0757-0407	6	4	RESISTOR 200 1% .125W F TC0+100	24546	C4-1/8-T0=201-F
A13R121	0757-0407	6		RESISTOR 200 1% .125W F TC0+100	24546	C4-1/8-T0=201-F
A13R122	0757-0317	7	1	RESISTOR 1.33K 1% .125W F TC0+100	24546	C4-1/8-T0=1331-F
A13R123	2100-3351	6	1	RESISTOR-TRMR 500 10% C SIDE-ADJ 1-TRN	28480	2100-3351
A13R124	0698-4425	0		RESISTOR 1.54K 1% .125W F TC0+100	24546	C4-1/8-T0=1541-F
A13R125	0757-0401	0		RESISTOR 100 1% .125W F TC0+100	24546	C4-1/8-T0=101-F
A13R126	0757-0401	0		RESISTOR 100 1% .125W F TC0+100	24546	C4-1/8-T0=101-F
A13R127	0757-0417	8	4	RESISTOR 562 1% .125W F TC0+100	24546	C4-1/8-T0=562R-F
A13R128	2100-3095	5	1	RESISTOR-TRMR 200 10% C SIDE-ADJ 17-TRN	02111	43P201
A13R129	0757-0417	8		RESISTOR 562 1% .125W F TC0+100	24546	C4-1/8-T0=562R-F
A13R130	0757-0401	0		RESISTOR 100 1% .125W F TC0+100	24546	C4-1/8-T0=101-F
A13R131	0757-0401	0		RESISTOR 100 1% .125W F TC0+100	24546	C4-1/8-T0=101-F
A13R140	0757-0401	0		RESISTOR 100 1% .125W F TC0+100	24546	C4-1/8-T0=101-F
A13R141	0757-0422	5		RESISTOR 909 1% .125W F TC0+100	24546	C4-1/8-T0=909R-F
A13R142	2100-3350	5	1	RESISTOR-TRMR 200 10% C SIDE-ADJ 1-TRN	28480	2100-3350
A13R143	0757-0407	6		RESISTOR 200 1% .125W F TC0+100	24546	C4-1/8-T0=201-F
A13R144	0757-0407	6		RESISTOR 200 1% .125W F TC0+100	24546	C4-1/8-T0=201-F
A13R200	0757-0394	0	8	RESISTOR 51.1 1% .125W F TC0+100	24546	C4-1/8-T0=51R1-F
A13R201	0757-0394	0		RESISTOR 51.1 1% .125W F TC0+100	24546	C4-1/8-T0=51R1-F
A13R202	0757-0346	2	2	RESISTOR 10 1% .125W F TC0+100	24546	C4-1/8-T0=10R0-F
A13R203	0757-0346	2		RESISTOR 10 1% .125W F TC0+100	24546	C4-1/8-T0=10R0-F
A13R204	0757-0280	3		RESISTOR 1K 1% .125W F TC0+100	24546	C4-1/8-T0=1001-F
A13R205	0757-0280	3		RESISTOR 1K 1% .125W F TC0+100	24546	C4-1/8-T0=1001-F
A13R206	0757-0280	3		RESISTOR 1K 1% .125W F TC0+100	24546	C4-1/8-T0=1001-F
A13R207	0757-0280	3		RESISTOR 1K 1% .125W F TC0+100	24546	C4-1/8-T0=1001-F
A13R208	0698-4444	3	2	RESISTOR 4.87K 1% .125W F TC0+100	24546	C4-1/8-T0=4871-F
A13R209	0698-4444	3		RESISTOR 4.87K 1% .125W F TC0+100	24546	C4-1/8-T0=4871-F
A13R210	2100-3123	0	1	RESISTOR-TRMR 500 10% C SIDE-ADJ 17-TRN	02111	43P501
A13R211	0698-4435	2		RESISTOR 2.49K 1% .125W F TC0+100	24546	C4-1/8-T0=2491-F
A13R212	0698-4425	0		RESISTOR 1.54K 1% .125W F TC0+100	24546	C4-1/8-T0=1541-F
A13R230	0698-4425	0		RESISTOR 1.54K 1% .125W F TC0+100	24546	C4-1/8-T0=1541-F
A13R231	0757-0401	0		RESISTOR 100 1% .125W F TC0+100	24546	C4-1/8-T0=101-F
A13R232	0757-0416	7		RESISTOR 511 1% .125W F TC0+100	24546	C4-1/8-T0=511R-F
A13R300	0698-4435	2		RESISTOR 2.49K 1% .125W F TC0+100	24546	C4-1/8-T0=2491-F
A13R301	0757-0394	0		RESISTOR 51.1 1% .125W F TC0+100	24546	C4-1/8-T0=51R1-F
A13R302	0757-0394	0		RESISTOR 51.1 1% .125W F TC0+100	24546	C4-1/8-T0=51R1-F
A13R303	0757-0417	8		RESISTOR 562 1% .125W F TC0+100	24546	C4-1/8-T0=562R-F
A13R304	0757-0417	8		RESISTOR 562 1% .125W F TC0+100	24546	C4-1/8-T0=562R-F
A13R305	0698-4037	0	6	RESISTOR 46.4 1% .125W F TC0+100	24546	C4-1/8-T0=46R4-F
A13R306	0698-4435	2		RESISTOR 2.49K 1% .125W F TC0+100	24546	C4-1/8-T0=2491-F
A13R307	0698-4037	0		RESISTOR 46.4 1% .125W F TC0+100	24546	C4-1/8-T0=46R4-F
A13R308	0698-4435	2		RESISTOR 2.49K 1% .125W F TC0+100	24546	C4-1/8-T0=2491-F
A13R310	0757-0384	4	2	RESISTOR 20 1% .125W F TC0+100	19701	MF4C1/8-T0=20R0-F
A13R311	0757-0384	4		RESISTOR 20 1% .125W F TC0+100	19701	MF4C1/8-T0=20R0-F
A13R312	0698-4037	0		RESISTOR 46.4 1% .125W F TC0+100	24546	C4-1/8-T0=46R4-F
A13R313	0698-4037	0		RESISTOR 46.4 1% .125W F TC0+100	24546	C4-1/8-T0=46R4-F
A13R314	0757-0394	0		RESISTOR 51.1 1% .125W F TC0+100	24546	C4-1/8-T0=51R1-F
A13R315	0757-0394	0		RESISTOR 51.1 1% .125W F TC0+100	24546	C4-1/8-T0=51R1-F
A13R316	0698-4037	0		RESISTOR 46.4 1% .125W F TC0+100	24546	C4-1/8-T0=46R4-F
A13R317	0698-4037	0		RESISTOR 46.4 1% .125W F TC0+100	24546	C4-1/8-T0=46R4-F
A13R318	0698-3437	2	4	RESISTOR 133 1% .125W F TC0+100	24546	C4-1/8-T0=133R-F
A13R319	0698-3437	2		RESISTOR 133 1% .125W F TC0+100	24546	C4-1/8-T0=133R-F
A13R320	0757-0401	0		RESISTOR 100 1% .125W F TC0+100	24546	C4-1/8-T0=101-F
A13R321	0698-3437	2		RESISTOR 133 1% .125W F TC0+100	24546	C4-1/8-T0=133R-F
A13R322	0698-3437	2		RESISTOR 133 1% .125W F TC0+100	24546	C4-1/8-T0=133R-F
A13R323	0757-0394	0		RESISTOR 51.1 1% .125W F TC0+100	24546	C4-1/8-T0=51R1-F
A13R324	0757-0394	0		RESISTOR 51.1 1% .125W F TC0+100	24546	C4-1/8-T0=51R1-F
A13U1	1826-0111	7	2	IC OP AMP GP DUAL TO-99	04713	MC1458G
A13U2	1826-0111	7		IC OP AMP GP DUAL TO-99	04713	MC1458G
A13U3	1826-0389	1	1	IC	28480	1826-0389
A13U4	1858-0030	6	1	TRANSISTOR ARRAY 16-PIN CER DIP	28480	1858-0030
A13VR1	1902-0041	4	1	DIODE-ZNR 5.11V 5% DO-7 PD=,4W TC=,009%	28480	1902-0041
A13VR100	1902-0048	1	1	DIODE-ZNR 6.81V 5% DO-7 PD=,4W TC=,043%	28480	1902-0048
A13VR200	1902-3048	7	2	DIODE-ZNR 3.48V 5% DO-7 PD=,4W TC=,058%	28480	1902-3048
A13VR300	1902-3048	6		DIODE-ZNR 3.48V 5% DO-7 PD=,4W TC=,058%	28480	1902-3048
A13VR301	1902-3203	7	1	DIODE-ZNR 14.7V 5% DO-7 PD=,4W TC=,057%	28480	1902-3203
A13W1	08165-61609	3	2	CABLE ASSEMBLY, VCO/AM	28480	08165-61609
A13W2	08165-61609	3		CABLE ASSEMBLY, VCO/AM	28480	08165-61609

SECTION VIII SERVICE

8-1 INTRODUCTION

8-2 This section contains the information to service the HP Model 8165A. The information includes theory of operation, troubleshooting, schematics, component layouts and block diagram.

8-3 The schematics and component layouts are organized as 'Service Sheets' which are identified by a large number within a square in the lower corners. A table relating these Service Sheets to board assemblies is given in Table 8-1. Schematic diagram symbols are given in Table 8-3.

Table 8-1. Index to Assemblies

Assembly	Service Sheet
A1 Keyboard	8A, 8D
A2 Display Board	8A, 8C, 8D
A3 Processor Board	8A, 8B, 8C, 8D
A4 Output Amplifier Board	4A, 4B, 4C, 9A, 9B
A5 Timing Board	2B, 2C
A6 Power Control Board	4A, 4C, 9A, 9B
A7 Burst Board	1
A8 VCO Control	2A, 6
A9 Reference Loop Board	5A, 5B
A10 Low Frequency Generator Board	3
A11 Sweep Generator Board	10
A12 Offset Generator Board	4C
A13 Amplitude Modulator Board	11
A14 HP-IB	7

8-4 SAFETY CONSIDERATIONS

8-5 This section contains warnings and cautions that must be followed for your protection and to avoid damage to the equipment:



Maintenance described herein is performed with power supplied to the instrument, and protective covers removed. Such maintenance should be performed only by service-trained personnel who are aware of the

hazards involved (for example, fire and electrical shock). Where maintenance can be performed without power applied, the power should be removed. When servicing is complete, the After Service Safety Check must be performed.

8-6 AFTER SERVICE SAFETY CHECK

8-7 Execute the following checks when servicing is completed.

8-8 Disconnect power cord from line. Visually inspect interior of instrument for any sign of abnormal internally generated heat, such as discolored printed circuit boards or components, damaged insulation, or evidence of arcing. Determine cause and remedy.

8-9 Check cabinet/ground pin continuity in accordance with IEC/VDE. Flex the power cord while making the measurement to detect any intermittent discontinuity. Check internal ground connections on boards and frame. Also check resistance of any front or rear panel ground terminals marked $\frac{1}{\text{E}}$.

8-10 Check cabinet/line isolation in accordance with IEC/VDE. Replace any component which results in a failure or refer to production Memo or Service Note issued by product division for alternate action.

8-11 Check line fuse to verify that the proper value is installed.

8-12 Check that safety covers are installed.

8-13 Check that all coaxial and flat cables inside are properly connected. Check that all boards and the heatsink on the chassis are properly connected. Verify that the board clamp is fitted.

8-14 Inform Hewlett-Packard (internally, the responsible product division) of any repeated failures in the above tests or any other safety features.

8-15 SERVICE BLOCKS (THEORY / TROUBLESHOOTING)

8-16 The theory of operation and troubleshooting

is divided into Service Blocks, each Service Block corresponding to a complete function within the 8165A. In addition to providing information on device bus data transfer, Service Block 1 also deals with overall instrument troubleshooting, including a detailed block diagram of all HP 8165A functions. The purpose of the general instrument troubleshooting is to provide a fast means of isolating a fault down to a function. The Serviceman should then proceed to the Service Block providing detailed theory of operation and troubleshooting hints for that function. A table relating function to Service Block is given in Table 8-2.

Table 8-2. Index to Service Blocks

Service Block	Function
1	Troubleshooting Tree/Device Bus Transfer
2	Burst
3	Frequency (VCO Control, VCO, Sine Shaper, Driver, Low Frequency Generator, Phase Locked Loop)
4	Output
5	Microprocessor and Display
6	Power Supply
7	Sweep
8	AM

8-17 Tables and Figures within each Service Block are given three-digit codes e.g. Figure 8-3-1. The first digit refers to the Manual Section (8), the second digit to the Service Block and the third to the Figure number, e.g. Figure 8-3-1 means Section 8, Service Block 3, Figure 1.

8-18 IC INFORMATION

8-19 IC information is given following Table 8-4. This information is in HP Part Number sequence and provides such details as pin assignments, truth tables and timing diagrams for individual IC's.

8-20 BOARD EXCHANGE PROGRAM

8-21 Hewlett-Packard operates a blue stripe exchange program for the microprocessor board A3 (08165-69503).

8-22 Handling procedure: Using the troubleshooting information in this section, the fault can be localized down to board level. If the faulty board is A3, it should be returned on the blue exchange program together with a description of the operating fault(s) caused by the board.

Table 8-3. Schematic Diagram Notes (1 of 2)

The following symbols conform, as far as possible, with ANSI Y 32.2, IEEE No. 315 and ANSI Y32.14 (for the logic symbols). These standards should be consulted when further informations is required.













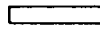

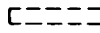
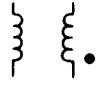

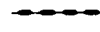

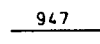







General		Components	
Units	Resistance values are in ohms, capacitance values in microfarads and inductance values in microhenries unless otherwise noted !		Normally open toggle switch. Circles (O) are used for the contacts to indicate a locking type switch.
P/O	Part of		Spring return, 2-position transfer switch. Triangle (▲) are used for the contacts to indicate a non-locking type switch.
*	Asterisk denotes a factory selected value. The value shown is the nominal value.		2-position, 2-pole slide switch.
	Encloses front panel nomenclature.		Air cored inductor.
	Encloses rear panel nomenclature.		Air cored transformer. The dot (●) is used, when necessary, to indicate instantaneous polarity.
	Heavy line indicates signal path.		Iron core
	Heavy dashed line indicates primary feedback path.		Ferrite core
	Wire colour code. Same as resistor colour code. First number is wire body colour.		Ferrite bead
	Wire or plug used as link.		Varactor diode
	Test point in a circuit. Point may/may not be identified on P.C. board.		Multi-junction diode
	Used with trimmer potentiometers or capacitors to indicate screwdriver adjustment.		Diode
	Direct connection to earth.		Zener diode
	Ground connection to instrument chassis or frame.		Schottky diode
	Used when a number of common-return connections are at the same potential. If there is more than one such system in the same circuit, numbers are written in the triangles so that all connections with the same potential have the same number.		Light Emitting Diode (LED)
	Specific potential difference with respect to a potential reference level, eg. +10 V		Photodiode
Schematic Referencing			Fuse
 <p>These references on a signal leaving a schematic diagram indicate the signal destination. The circle contains the signal number and the square contains the number of the schematic to which that signal goes.</p> <p>These references on a signal entering a schematic diagram indicate the signal origin. The circle contains the signal number and the square contains the number of the schematic to which that signal originates.</p>			Neon
			Filament lamp

Table 8-3. Schematic Diagram Notes (2 of 2)

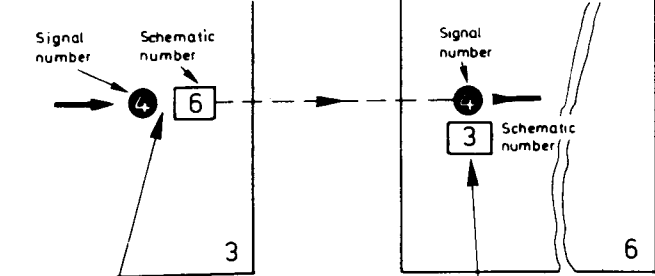

1820-0491

BCD-TO-DECIMAL DECODERS/DRIVERS

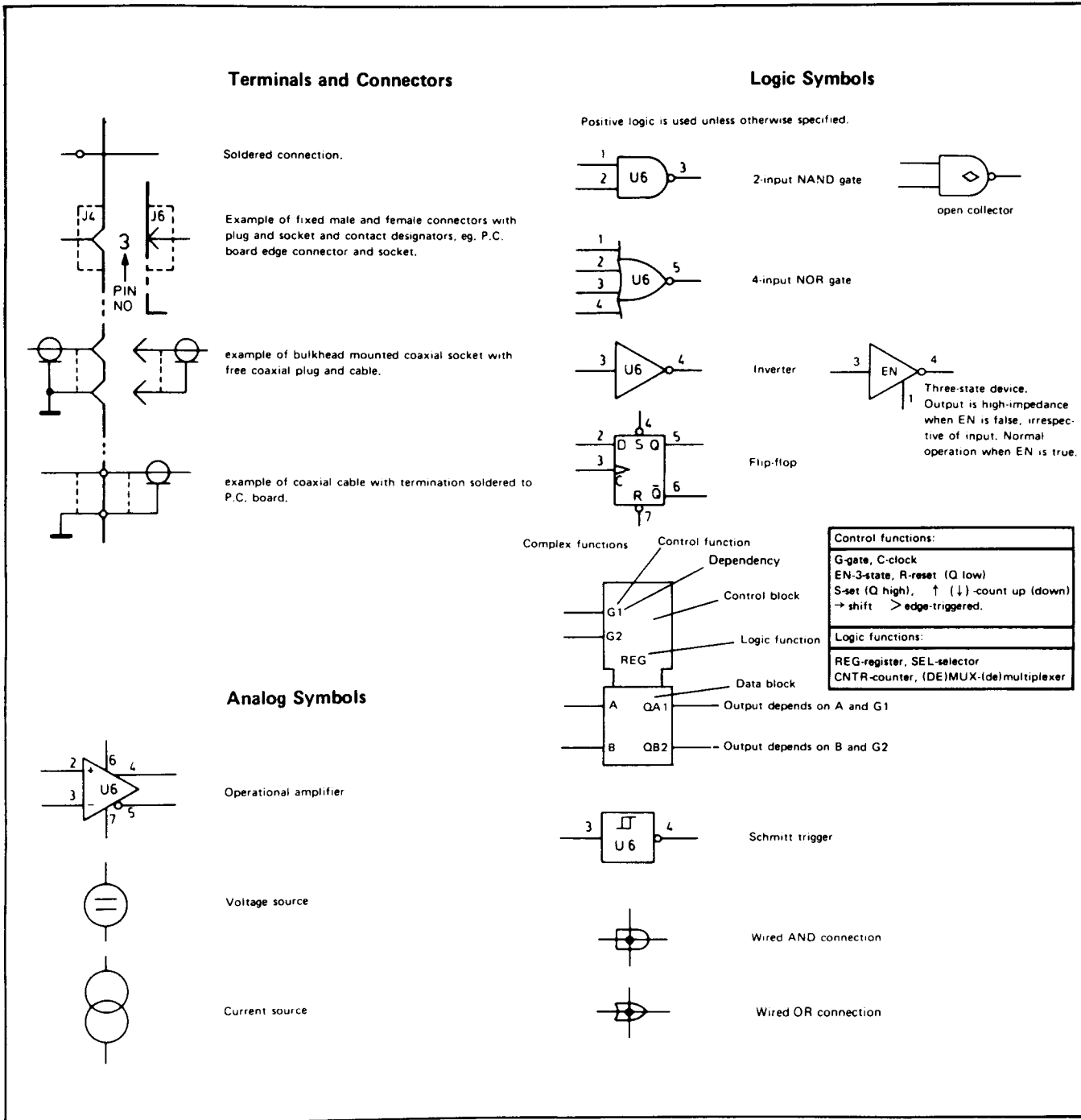
FUNCTION TABLE

NO.	INPUTS				OUTPUTS									
	D	C	B	A	0	1	2	3	4	5	6	7	8	9
0	L	L	L	L	L	H	H	H	H	H	H	H	H	H
1	L	L	L	H	H	L	H	H	H	H	H	H	H	H
2	L	L	H	L	H	H	L	H	H	H	H	H	H	H
3	L	L	H	H	H	H	L	H	H	H	H	H	H	H
4	L	H	L	L	H	H	H	L	H	H	H	H	H	H
5	L	H	L	H	H	H	H	H	L	H	H	H	H	H
6	L	H	H	L	H	H	H	H	H	L	H	H	H	H
7	L	H	H	H	H	H	H	H	H	H	L	H	H	H
8	H	L	L	L	H	H	H	H	H	H	H	L	H	H
9	H	L	L	H	H	H	H	H	H	H	H	H	L	H
INVALID	H	L	H	L	H	H	H	H	H	H	H	H	H	H
	H	L	H	H	H	H	H	H	H	H	H	H	H	H
	H	H	L	L	H	H	H	H	H	H	H	H	H	H
	H	H	L	H	H	H	H	H	H	H	H	H	H	H
	H	H	H	L	H	H	H	H	H	H	H	H	H	H

H = high level (off), L = low level (on)

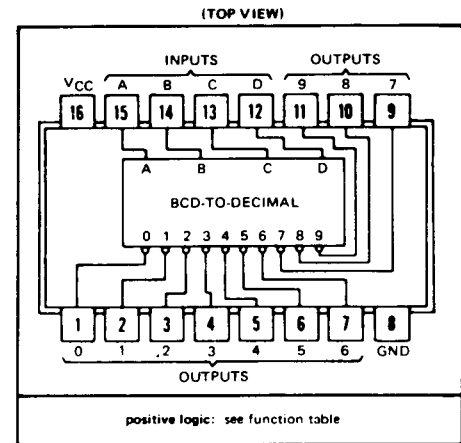

1820-0495

4-LINE-TO-16-LINE DECODERS/DEMULTIPLEXERS

logic

FUNCTION TABLE

INPUTS		OUTPUTS																			
G1	G2	D	C	B	A	0	1	2	3	4	5	6	7	8	9	10	11	12	13	14	15
L	L	L	L	L	L	L	H	H	H	H	H	H	H	H	H	H	H	H	H	H	H
L	L	L	L	L	H	H	L	H	H	H	H	H	H	H	H	H	H	H	H	H	H
L	L	L	L	H	L	H	H	L	H	H	H	H	H	H	H	H	H	H	H	H	H
L	L	L	L	H	H	H	H	L	H	H	H	H	H	H	H	H	H	H	H	H	H
L	L	L	H	L	L	H	H	H	L	H	H	H	H	H	H	H	H	H	H	H	H
L	L	L	H	L	H	H	H	H	H	L	H	H	H	H	H	H	H	H	H	H	H
L	L	L	H	H	L	H	H	H	H	H	L	H	H	H	H	H	H	H	H	H	H
L	L	L	H	H	H	H	H	H	H	H	H	L	H	H	H	H	H	H	H	H	H
L	L	H	L	L	L	H	H	H	H	H	H	H	L	H	H	H	H	H	H	H	H
L	L	H	L	H	H	H	H	H	H	H	H	H	H	L	H	H	H	H	H	H	H
L	L	H	H	L	L	H	H	H	H	H	H	H	H	H	L	H	H	H	H	H	H
L	L	H	H	H	L	H	H	H	H	H	H	H	H	H	H	L	H	H	H	H	H
L	L	H	H	H	H	H	H	H	H	H	H	H	H	H	H	H	L	H	H	H	H
L	L	H	H	H	H	H	H	H	H	H	H	H	H	H	H	H	H	L	H	H	H
L	H	X	X	X	X	H	H	H	H	H	H	H	H	H	H	H	H	H	H	H	H
H	L	X	X	X	X	H	H	H	H	H	H	H	H	H	H	H	H	H	H	H	H
H	H	X	X	X	X	H	H	H	H	H	H	H	H	H	H	H	H	H	H	H	H

H = high level, L = low level, X = Irrelevant

functional block diagram and schematics of inputs and outputs

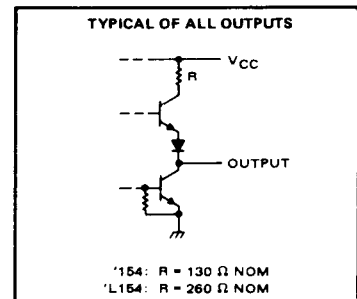
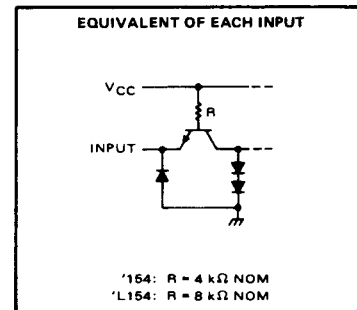
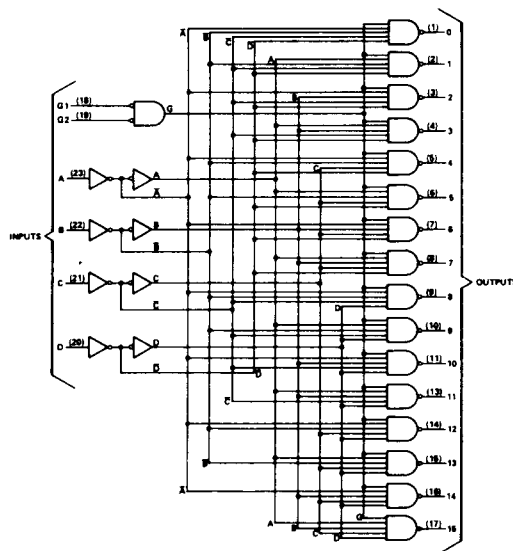

1820-0567

VOLTAGE CONTROLLED MULTIVIBRATOR (MC 4024 P)

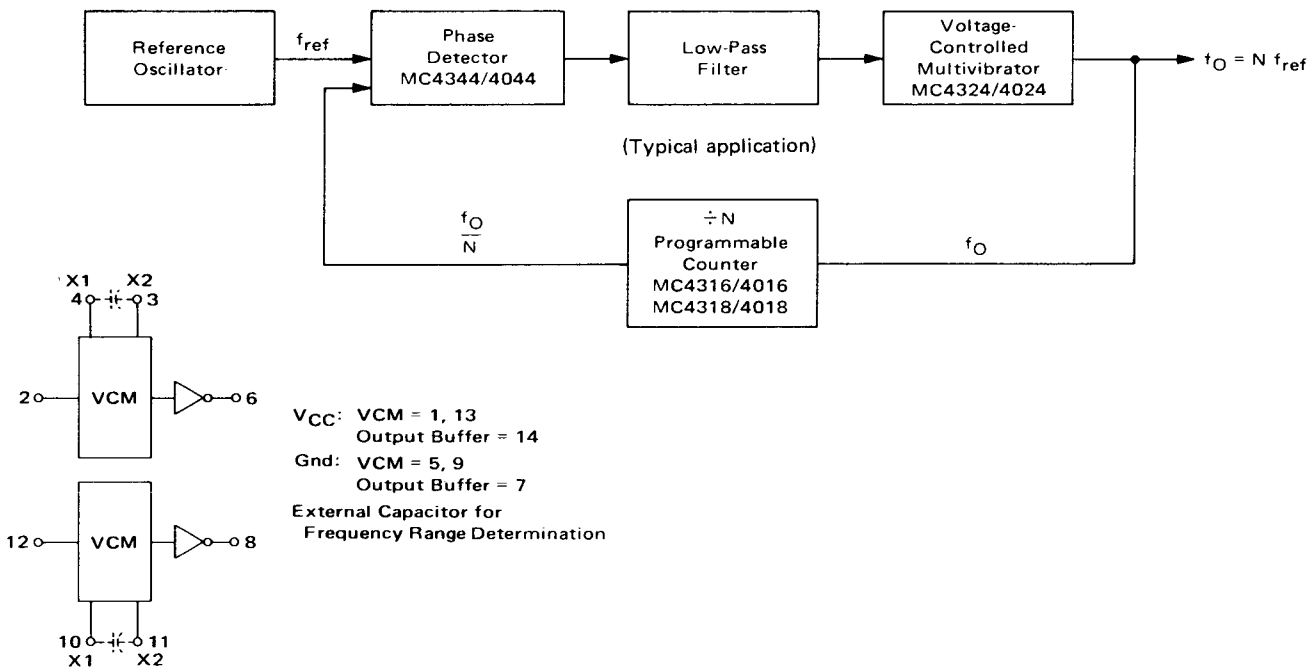

1820-0628

64-BIT READ/WRITE MEMORY

functional block diagram

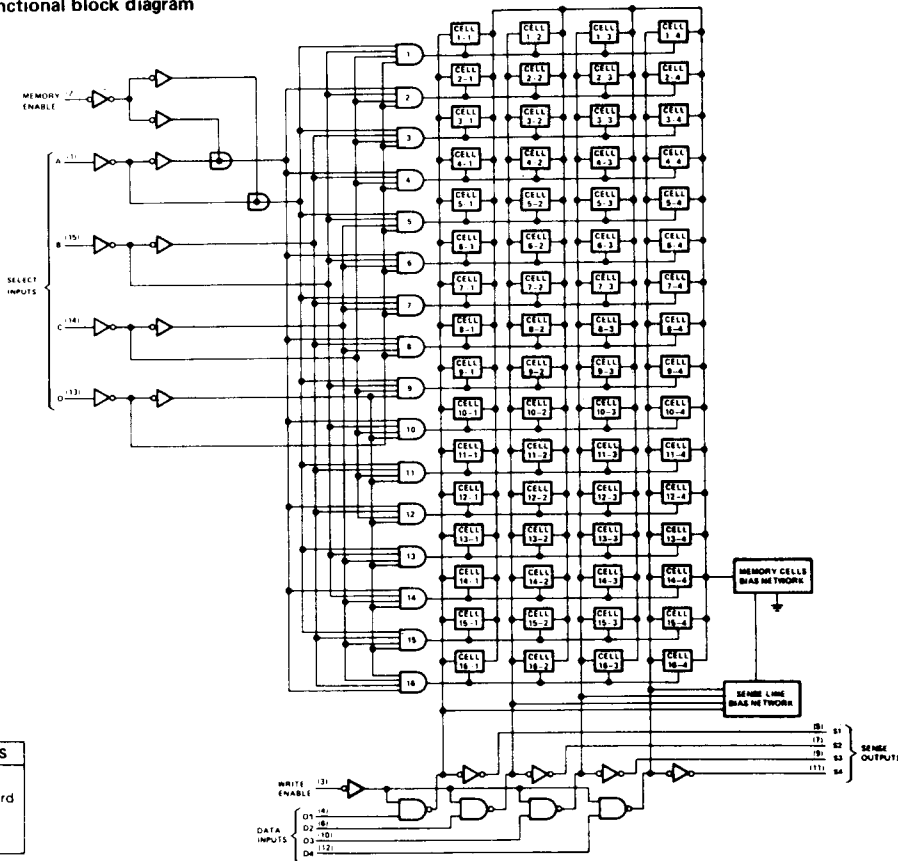

FUNCTION TABLE

ME	WE	OPERATION	CONDITION OF OUTPUTS
L	L	Write	Complement of Data Inputs
L	H	Read	Complement of Selected Word
H	L	Inhibit Storage	Complement of Data Inputs
H	H	Do Nothing	High

1820-0629

DUAL J-K NEGATIVE-EDGE-TRIGGERED FLIP-FLOPS WITH PRESET AND CLEAR

FUNCTION TABLE

INPUTS					OUTPUTS	
PRESET	CLEAR	CLOCK	J	K	Q	\bar{Q}
L	H	X	X	X	H	L
H	L	X	X	X	L	H
L	L	X	X	X	H*	H*
H	H	↓	L	L	Q ₀	\bar{Q}_0
H	H	↓	H	L	H	L
H	H	↓	L	H	L	H
H	H	↓	H	H	TOGGLE	
H	H	H	X	X	Q ₀	\bar{Q}_0

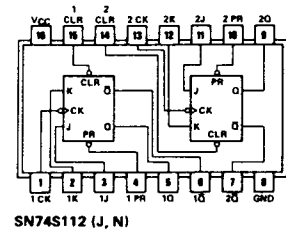

1820-0751

50/30/100-MHz PRESETTABLE DECADE OR BINARY COUNTERS/LATCHES

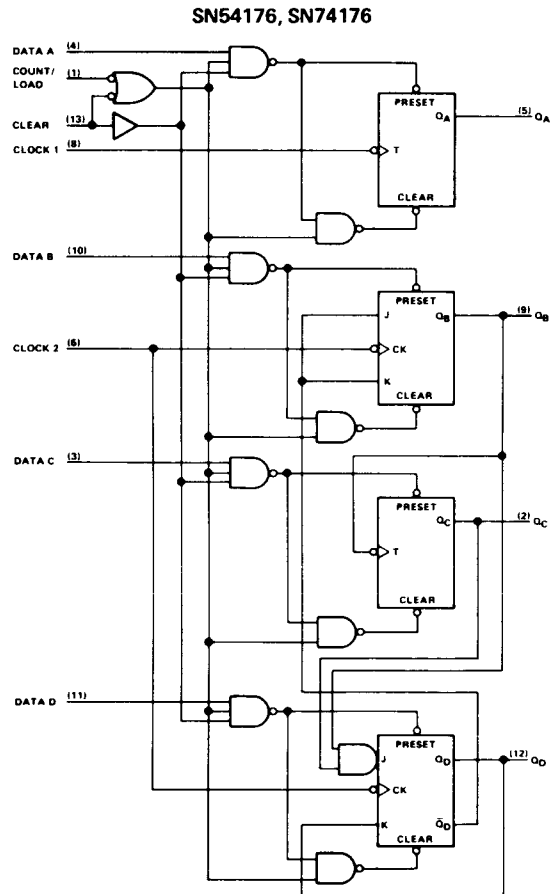
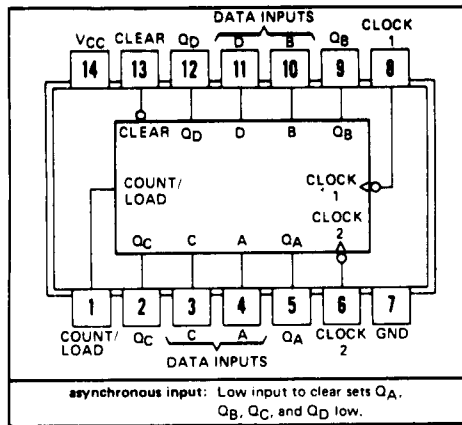

⚡ . . . dynamic input activated by transition from a high level to a low level

1820-0802

QUAD 2-INPUT NOR GATE

POSITIVE LOGIC

NEGATIVE LOGIC

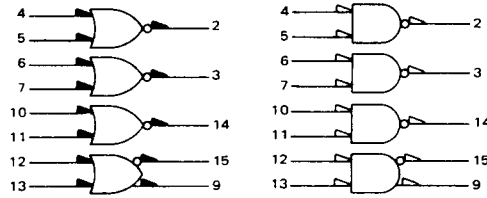

V_{CC1} = Pin 1
 V_{CC2} = Pin 16
 V_{EE} = Pin 8

1820-0817

Dual Type D Master-Slave Flip-Flop

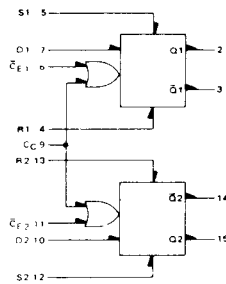

CLOCKED TRUTH TABLE

C	D	Q _{n+1}
L	0	Q _n
L	L	L
H	H	H

0 - Don't Care
 C - C_E - C_C
 A clock H is a clock transition from a low to a high state

R-S TRUTH TABLE

R	S	Q _{n+1}
L	L	Q _n
L	H	H
H	L	L
H	H	ND

N.D. - Not Defined

V_{CC1} = Pin 1
 V_{CC2} = Pin 16
 V_{EE} = Pin 8

1820-1114

BINARY UP/DOWN COUNTER

TRUTH TABLE

CARRY IN	UP/DOWN	PRESET ENABLE	RESET	ACTION
1	X	0	0	No Count
0	1	0	0	Count Up
0	0	0	0	Count Down
X	X	1	0	Preset
X	X	X	1	Reset

X = Don't Care

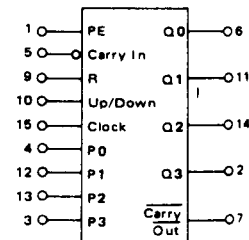

V_{DD} = Pin 16
 V_{SS} = Pin 8

1820-1122

DUAL BCD UP COUNTER (MC14518B)

TRUTH TABLE

CLOCK	ENABLE	RESET	ACTION
	1	0	Increment Counter
0		0	Increment Counter
	X	0	No Change
X		0	No Change
	0	0	No Change
1		0	No Change
X	X	1	Q0 thru Q3 = 0

X = Don't Care

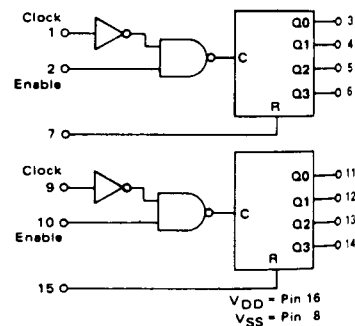

V_{DD} = Pin 16
 V_{SS} = Pin 8

1820-1188

PHASE-LOCKED LOOP

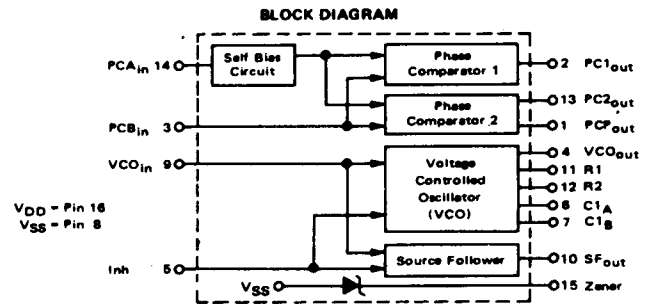

1820-1193

50/30/100-MHz PRESETTABLE DECADE OR BINARY COUNTERS/LATCHES

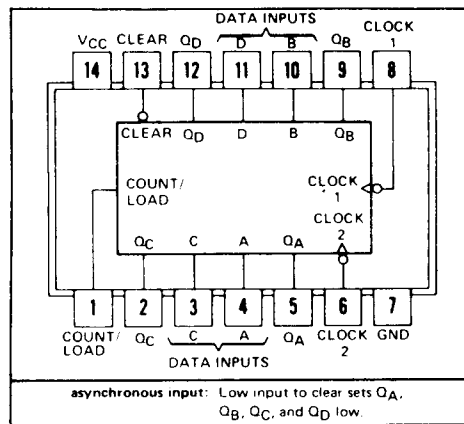

SN54177, SN74177

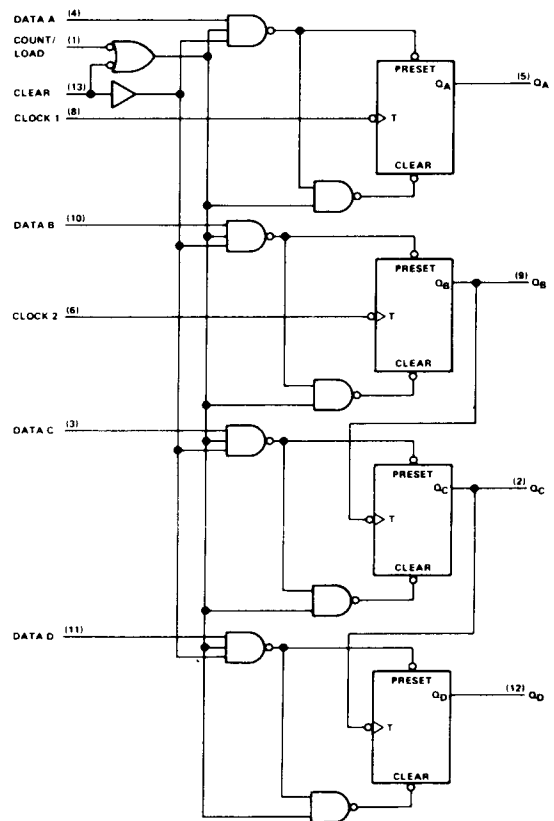

1820-1194

SYNCHRONOUS 4-BIT UP/DOWN COUNTERS (DUAL CLOCK WITH CLEAR)

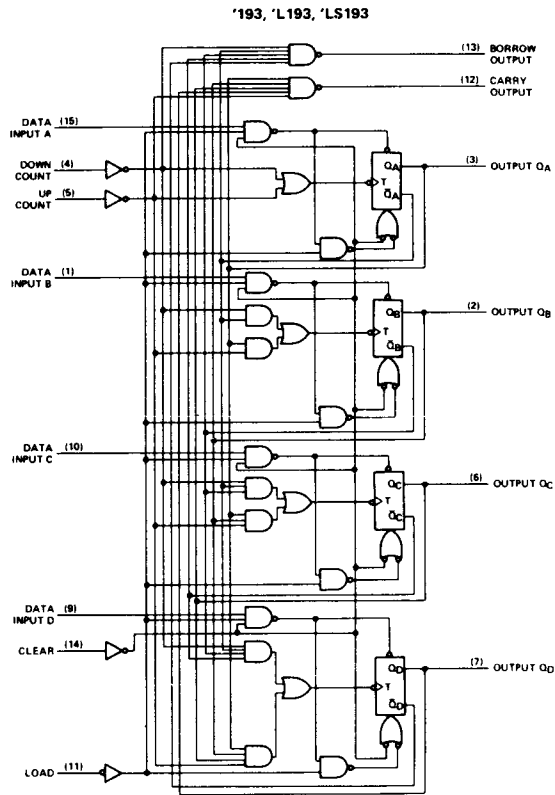
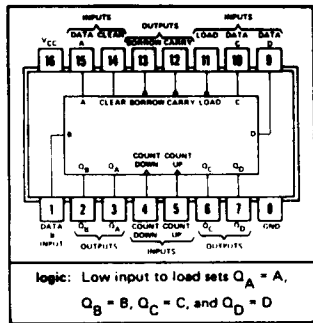

1820-1197

QUADRUPLE 2-INPUT POSITIVE-NAND GATES

positive logic:
 $Y = \overline{AB}$

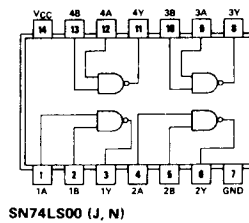

1820-1212

DUAL J-K NEGATIVE-EDGE-TRIGGERED FLIP-FLOPS WITH PRESET AND CLEAR

FUNCTION TABLE

PRESET		CLEAR		CLOCK	J	K	OUTPUTS	
1	2	3	4				Q	\overline{Q}
L	H	X	X	X	X	X	H	L
H	L	X	X	X	X	X	L	H
L	L	X	X	X	X	X	H*	H*
H	H	↓	↓	L	L	L	Q ₀	\overline{Q}_0
H	H	↓	↓	H	L	L	H	L
H	H	↓	↓	L	H	L	L	H
H	H	↓	↓	H	H	H	TOGGLE	
H	H	H	H	X	X	X	Q ₀	\overline{Q}_0

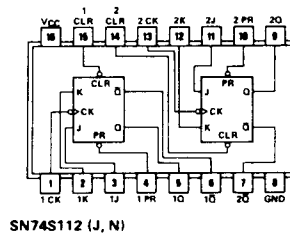

1820-1217

DATA SELECTORS/MULTIPLEXERS

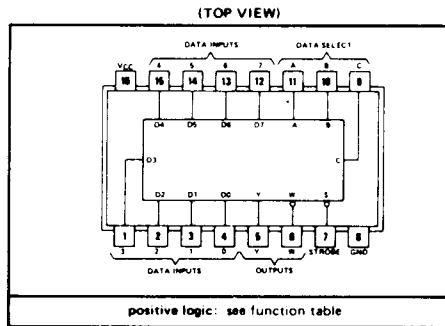

'151A, 'LS151, 'S151
FUNCTION TABLE

INPUTS				OUTPUTS	
SELECT			STROBE	Y	W
C	B	A	S		
X	X	X	H	L	H
L	L	L	L	D0	$\overline{D0}$
L	L	H	L	D1	$\overline{D1}$
L	H	L	L	D2	$\overline{D2}$
L	H	H	L	D3	$\overline{D3}$
H	L	L	L	D4	$\overline{D4}$
H	L	H	L	D5	$\overline{D5}$
H	H	L	L	D6	$\overline{D6}$
H	H	H	L	D7	$\overline{D7}$

H = high level, L = low level, X = irrelevant
 E0, E1, ... E15 = the complement of the level of the respective E input
 D0, D1, ... D7 = the level of the D respective input

1820-1241

8-CHANNEL DATA SELECTOR

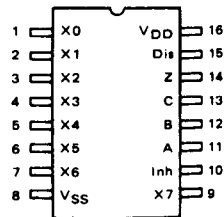

TRUTH TABLE

C	B	A	INHIBIT	DISABLE	Z
0	0	0	0	0	X0
0	0	1	0	0	X1
0	1	0	0	0	X2
0	1	1	0	0	X3
1	0	0	0	0	X4
1	0	1	0	0	X5
1	1	0	0	0	X6
1	1	1	0	0	X7
φ	φ	φ	1	0	0
φ	φ	φ	φ	1	High Impedance

φ = Don't Care

1820-1244

DUAL 4-LINE-TO-1-LINE DATA SELECTORS/MULTIPLEXERS

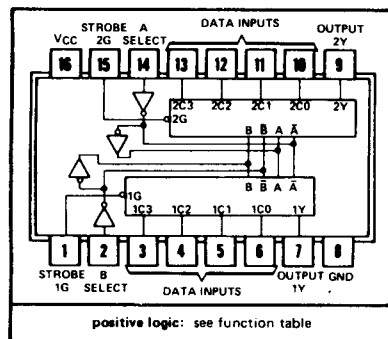

FUNCTION TABLE

SELECT INPUTS		DATA INPUTS				STROBE	OUTPUT
B	A	C0	C1	C2	C3	G	Y
X	X	X	X	X	X	H	L
L	L	L	X	X	X	L	L
L	L	H	X	X	X	L	H
L	H	X	L	X	X	L	L
L	H	X	H	X	X	L	H
H	L	X	X	L	X	L	L
H	L	X	X	H	X	L	H
H	H	X	X	X	L	L	L
H	H	X	X	X	H	L	H

Select inputs A and B are common to both sections.
 H = high level, L = low level, X = irrelevant

1820-1266

TRI-STATE® Hex Buffers

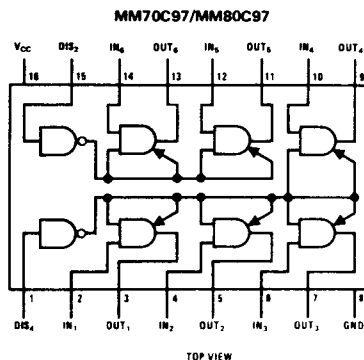

MM70C97/MM80C97

DISABLE DIS4	INPUT DIS2	INPUT	OUTPUT
0	0	0	0
0	0	1	1
X	1	X	H-z*
1	X	X	H-z**

*Output 5-6 only
 **Output 1-4 only
 X = Irrelevant

1820-1278

SYNCHRONOUS UP/DOWN COUNTERS WITH DOWN/UP MODE CONTROL

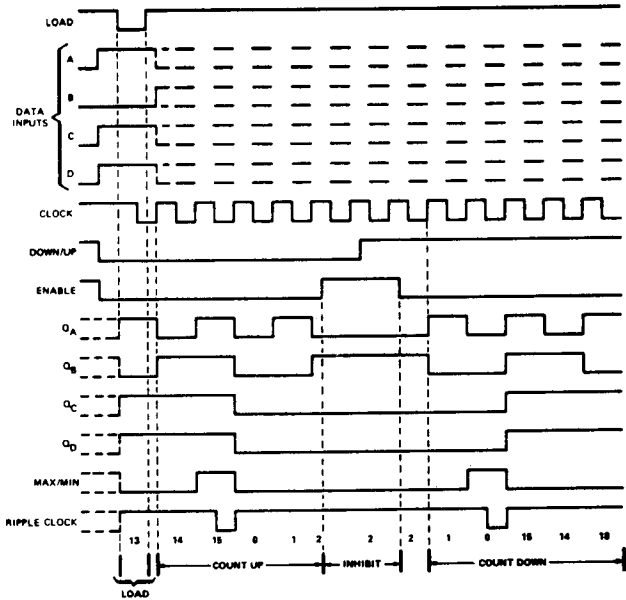

'191, 'LS191 BINARY COUNTERS

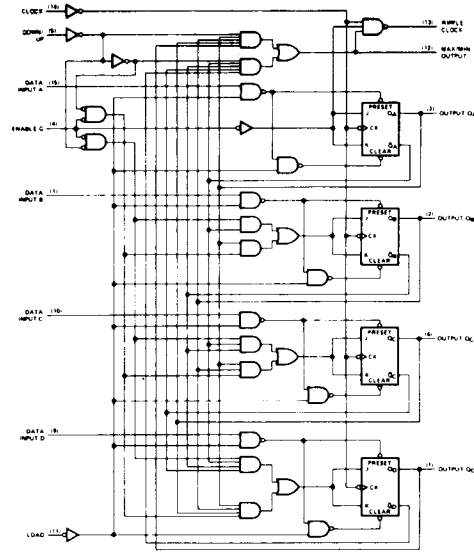

1820-1279

SYNCHRONOUS UP/DOWN COUNTERS WITH DOWN/UP MODE CONT.

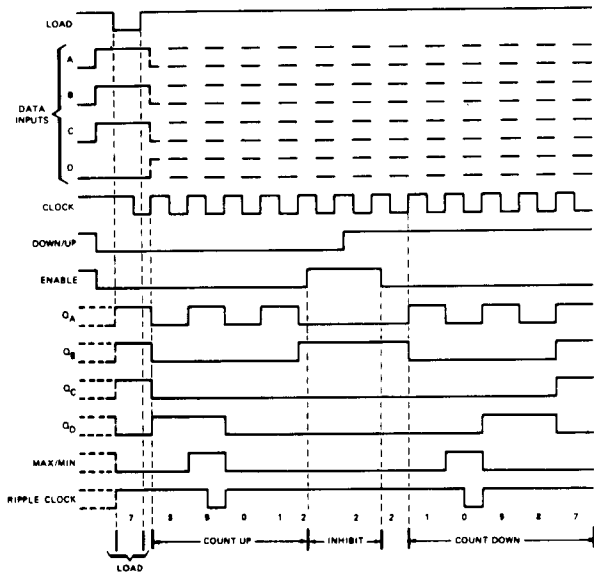

'190, 'LS190 DECADE COUNTERS

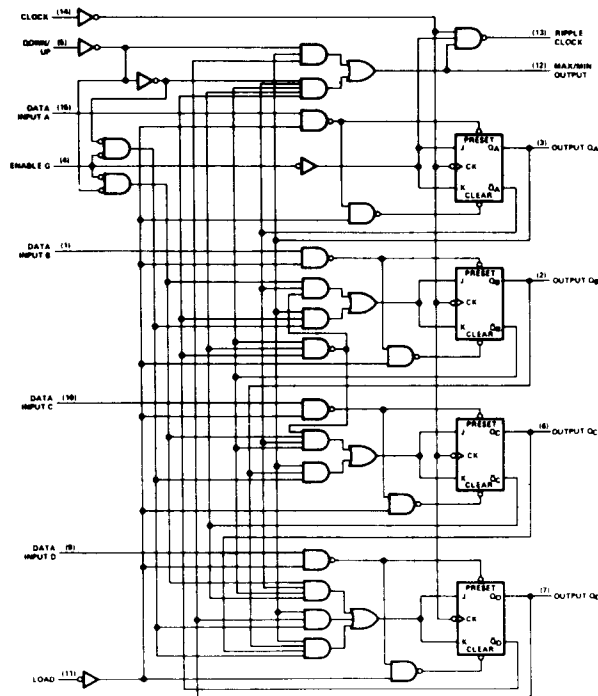

1820-1340 4-BIT MAGNITUDE COMPARATOR

4 (A > B)_{in}
 6 (A = B)_{in}
 5 (A < B)_{in} (A > B)_{out} — O13
 10 A0
 11 B0
 7 A1 (A = B)_{out} — O3
 9 B1
 2 A2
 1 B2 (A < B)_{out} — O12
 15 A3
 14 B3
 VDD = Pin 16
 VSS = Pin 8

TRUTH TABLE

		INPUTS					OUTPUTS		
		COMPARING			CASCADING		A < B	A = B	A > B
A3, B3	A2, B2	A1, B1	A0, B0	A < B	A = B	A > B	A < B	A = B	A > B
A3 > B3	X	X	X	X	X	1	0	0	1
A3 = B3	A2 > B2	X	X	X	X	1	0	0	1
A3 = B3	A2 = B2	A1 > B1	X	X	X	1	0	0	1
A3 = B3	A2 = B2	A1 = B1	A0 > B0	X	X	1	0	0	1
A3 = B3	A2 = B2	A1 = B1	A0 = B0	0	0	1	0	0	1
A3 = B3	A2 = B2	A1 = B1	A0 = B0	0	1	1	0	1	0
A3 = B3	A2 = B2	A1 = B1	A0 = B0	1	0	1	1	0	0
A3 = B3	A2 = B2	A1 = B1	A0 < B0	X	X	X	1	0	0
A3 = B3	A2 = B2	A1 < B1	X	X	X	X	1	0	0
A3 = B3	A2 < B2	X	X	X	X	X	1	0	0
A3 < B3	X	X	X	X	X	X	1	0	0

X = Don't Care

1820-1400 QUAD 2-INPUT AND GATE

POSITIVE LOGIC

NEGATIVE LOGIC

VCC1 = Pin 1
 VCC2 = Pin 16
 VEE = Pin 8

1820-1418 4-LINE-TO-10-LINE DECODERS (1-OF-10)

FUNCTION TABLE

NO.	BCD INPUT			
	D	C	B	A
0	L	L	L	L
1	L	L	L	H
2	L	L	H	L
3	L	L	H	H
4	L	H	L	L
5	L	H	L	H
6	L	H	H	L
7	L	H	H	H
8	H	L	L	L
9	H	L	L	H
INVALID	H	L	H	L
	H	L	H	H
	H	H	L	L
	H	H	L	H
	H	H	H	H

positive logic: see function table

1820-1423 RETRIGGERABLE MONOSTABLE MULTIVIBRATORS

'123, 'L123, 'LS123 FUNCTION TABLE

CLEAR	INPUTS		OUTPUTS	
	A	B	Q	Q̄
L	X	X	L	H
X	H	X	L	H
X	X	L	L	H
H	L	↑	⌈	⌋
H	↑	H	⌈	⌋
↑	L	H	⌈	⌋

logic: see function table

1820-1442

DECADE AND 4-BIT BINARY COUNTERS

'290, 'LS290
BCD COUNT SEQUENCE
(See Note A)

COUNT	OUTPUT			
	Q _D	Q _C	Q _B	Q _A
0	L	L	L	L
1	L	L	L	H
2	L	L	H	L
3	L	L	H	H
4	L	H	L	L
5	L	H	L	H
6	L	H	H	L
7	L	H	H	H
8	H	L	L	L
9	H	L	L	H

'290, 'LS290
BI-QUINARY (5-2)
(See Note B)

COUNT	OUTPUT			
	Q _A	Q _D	Q _C	Q _B
0	L	L	L	L
1	L	L	L	H
2	L	L	H	L
3	L	L	H	H
4	L	H	L	L
5	H	L	L	L
6	H	L	L	H
7	H	L	H	L
8	H	L	H	H
9	H	H	L	L

'290, 'LS290
RESET/COUNT FUNCTION TABLE

RESET INPUTS				OUTPUT			
R ₀ (1)	R ₀ (2)	R ₉ (1)	R ₉ (2)	Q _D	Q _C	Q _B	Q _A
H	H	L	X	L	L	L	L
H	H	X	L	L	L	L	L
X	X	H	H	H	L	L	H
X	L	X	L	COUNT			
L	X	L	X	COUNT			
L	X	X	L	COUNT			
X	L	L	X	COUNT			

- NOTES: A. Output Q_A is connected to input B for BCD count.
 B. Output Q_D is connected to input A for bi-quinary count.
 C. Output Q_A is connected to input B.
 D. H = high level, L = low level, X = irrelevant

functional block diagrams

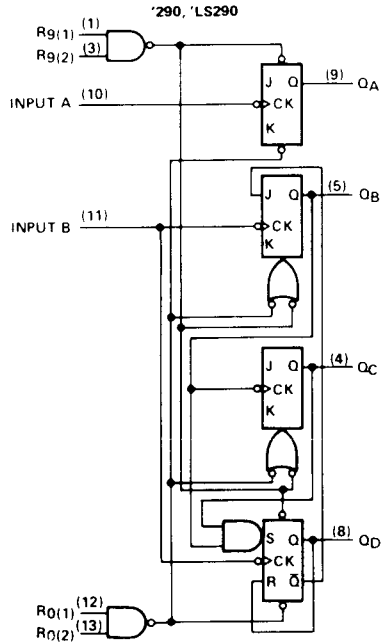

1820-1443

DECADE AND 4-BIT BINARY COUNTERS

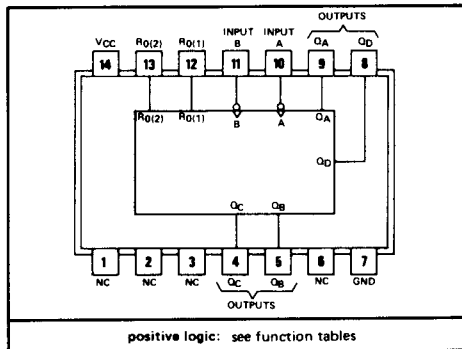

NC—No internal connection

'293, 'LS293
COUNT SEQUENCE
(See Note C)

COUNT	OUTPUT			
	Q _D	Q _C	Q _B	Q _A
0	L	L	L	L
1	L	L	L	H
2	L	L	H	L
3	L	L	H	H
4	L	H	L	L
5	L	H	L	H
6	L	H	H	L
7	L	H	H	H
8	H	L	L	L
9	H	L	L	H
10	H	L	H	L
11	H	L	H	H
12	H	H	L	L
13	H	H	L	H
14	H	H	H	L
15	H	H	H	H

'293, 'LS293
RESET/COUNT FUNCTION TABLE

RESET INPUTS		OUTPUT			
R ₀ (1)	R ₀ (2)	Q _D	Q _C	Q _B	Q _A
H	H	L	L	L	L
L	X	COUNT			
X	L	COUNT			

'293, 'LS293

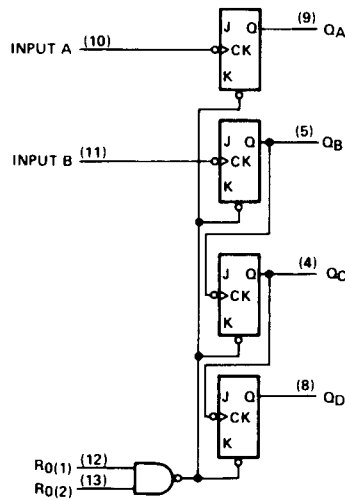

1820-1445

4-BIT BISTABLE LATCHES

FUNCTION TABLE
(EACH LATCH)

INPUTS		OUTPUTS	
D	G	Q	\bar{Q}
L	H	L	H
H	H	H	L
X	L	Q ₀	\bar{Q} ₀

H = high level, L = low level, X = irrelevant
Q₀ = the level of Q before the high-to-low transition of G.

functional block diagram (each latch)

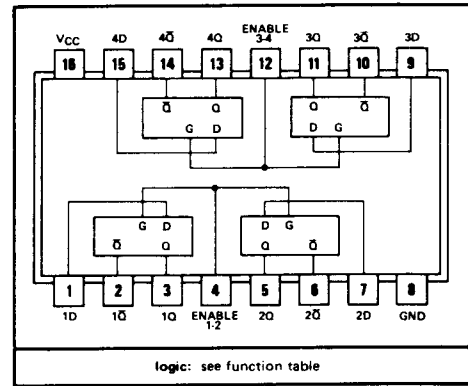
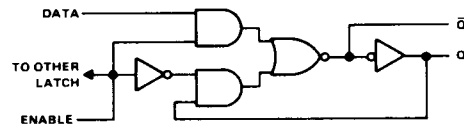

1820-1485

Monostable Multivibrator

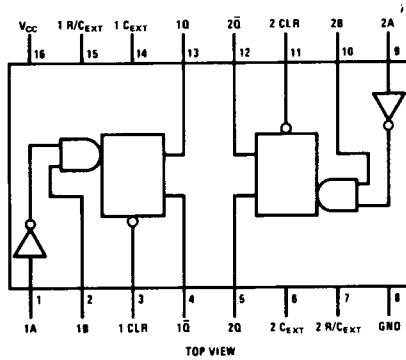

INPUTS			OUTPUTS	
CLEAR	A	B	Q	\bar{Q}
L	X	X	L	H
X	H	X	L	H
X	X	L	L	H
H	L	↑	[Pulse]	[Pulse]
H	↓	H	[Pulse]	[Pulse]

H = High level
L = Low level
↑ = Transition from low to high
↓ = Transition from high to low
[Pulse] = One high level pulse
[Pulse] = One low level pulse
X = Irrelevant

1820-1644

BCD-TO-SEVEN-SEGMENT DECODERS/DRIVERS

'248, '249, 'LS248, 'LS249

FUNCTION TABLE

DECIMAL OR FUNCTION	INPUTS						BI/RBO†	OUTPUTS							NOTE
	LT	RBI	D	C	B	A		a	b	c	d	e	f	g	
0	H	H	L	L	L	L	H	H	H	H	H	H	L	1	
1	H	X	L	L	L	H	H	L	H	H	L	L	L	1	
2	H	X	L	L	H	L	H	H	H	L	H	H	L	1	
3	H	X	L	L	H	H	H	H	H	H	L	L	H	1	
4	H	X	L	H	L	L	H	L	H	H	L	L	H	1	
5	H	X	L	H	L	H	H	H	L	H	H	L	H	1	
6	H	X	L	H	H	L	H	H	L	H	H	H	H	1	
7	H	X	L	H	H	H	H	H	H	H	L	L	L	1	
8	H	X	H	L	L	L	H	H	H	H	H	H	H	1	
9	H	X	H	L	L	H	H	H	H	H	L	H	H	1	
10	H	X	H	L	H	L	H	L	L	L	H	H	L	1	
11	H	X	H	L	H	H	H	L	L	H	H	L	L	1	
12	H	X	H	H	L	L	H	L	H	L	L	L	H	1	
13	H	X	H	H	L	H	H	H	L	L	L	H	H	1	
14	H	X	H	H	H	L	H	L	L	L	H	H	H	1	
15	H	X	H	H	H	H	H	L	L	L	L	L	L	1	
BI	X	X	X	X	X	X	L	L	L	L	L	L	L	2	
RBI	H	L	L	L	L	L	L	L	L	L	L	L	L	3	
LT	L	X	X	X	X	X	H	H	H	H	H	H	H	4	

H = high level, L = low level, X = irrelevant

- NOTES:
1. The blanking input (BI) must be open or held at a high logic level when output functions 0 through 15 are desired. The ripple-blanking input (RBI) must be open or high if blanking of a decimal zero is not desired.
 2. When a low logic level is applied directly to the blanking input (BI), all segment outputs are low regardless of the level of any other input.
 3. When ripple-blanking input (RBI) and inputs A, B, C, and D are at a low level with the lamp test input high, all segment outputs go low and the ripple-blanking output (RBO) goes to a low level (response condition).
 4. When the blanking input/ripple-blanking output (BI/RBO) is open or held high and a low is applied to the lamp-test input, all segment outputs are high.

†BI/RBO is wire-AND logic serving as blanking input (BI) and/or ripple-blanking output (RBO).

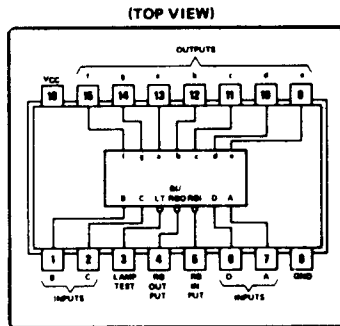

'248, '249, 'LS248, 'LS249

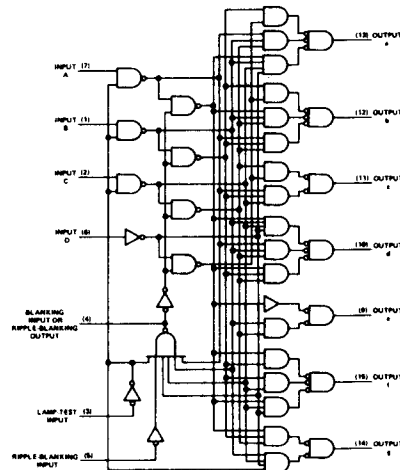

1820-1956

QUAD LATCH

TRUTH TABLE

CLOCK	POLARITY	Q
0	0	Data
1	0	Latch
1	1	Data
1	1	Latch

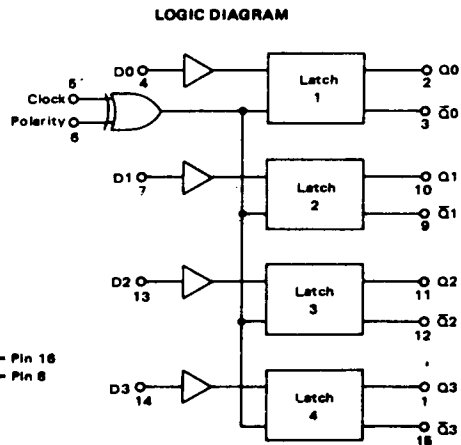

1820-1963

DUAL TYPE D FLIP-FLOP

TRUTH TABLE

CLOCK†	INPUTS			OUTPUTS	
	DATA	RESET	SET	Q	\bar{Q}
	0	0	0	0	1
	1	0	0	1	0
	X	0	0	Q	\bar{Q}
	X	1	0	0	1
X	X	0	1	1	0
X	X	1	1	1	1

No Change

X = Don't Care
† = Level Change

BLOCK DIAGRAM

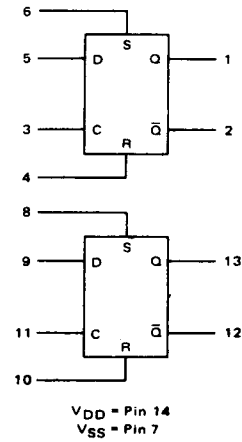

1820-1964

DUAL J-K FLIP-FLOP

TRUTH TABLE

C†	INPUTS				OUTPUTS*		
	J	K	S	R	Q _n ‡	Q _{n+1}	\bar{Q}_{n+1}
	1	X	0	0	0	1	0
	X	0	0	0	0	1	0
	0	X	0	0	0	0	1
	X	1	0	0	1	0	1
	X	X	0	0	X	Q _n	\bar{Q}_n
X	X	X	1	0	X	1	0
X	X	X	0	1	X	0	1
X	X	X	1	1	X	1	1

No Change

X = Don't Care
† = Level Change
‡ = Present State
* = Next State

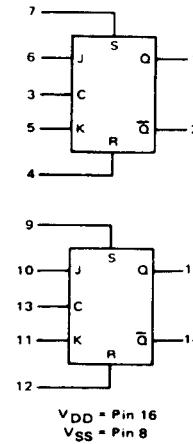

1820-1976

HEX BUFFERS
Noninverting

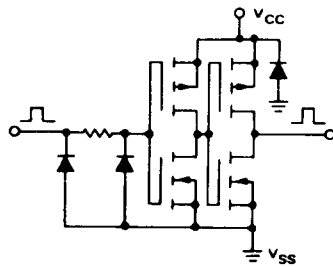

MC14050B

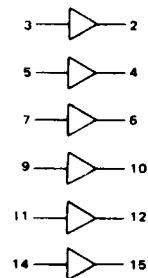

NC = Pin 13, 16
VSS = Pin 8
VCC = Pin 1

1826-0180

TIMER

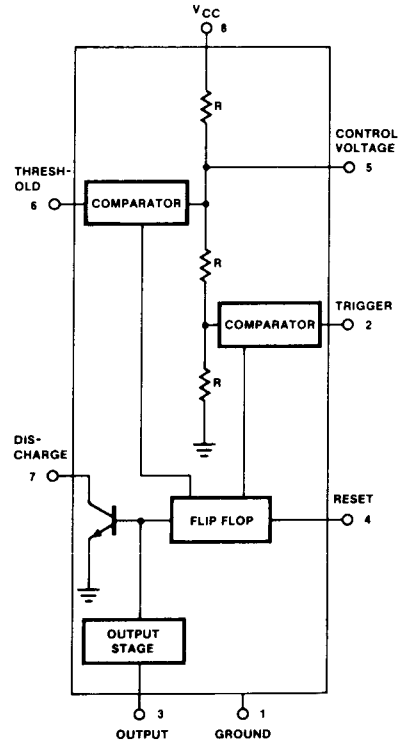
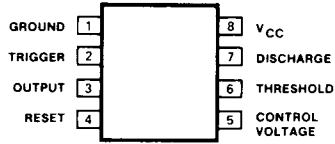

1826-0188

EIGHT-BIT MULTIPLYING DIGITAL-TO-ANALOG CONVERTER

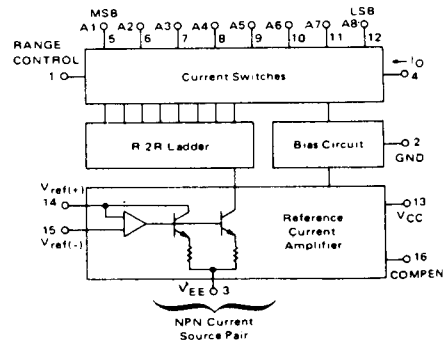

1826-0462

TEN BIT, MULTIPLYING DIGITAL-TO-ANALOG CONVERTER

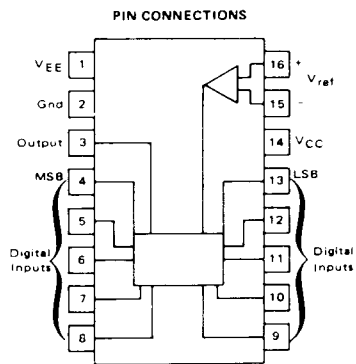
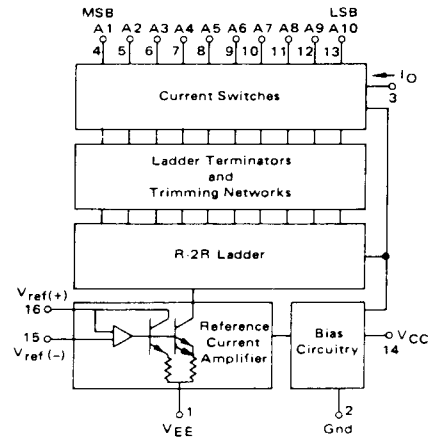
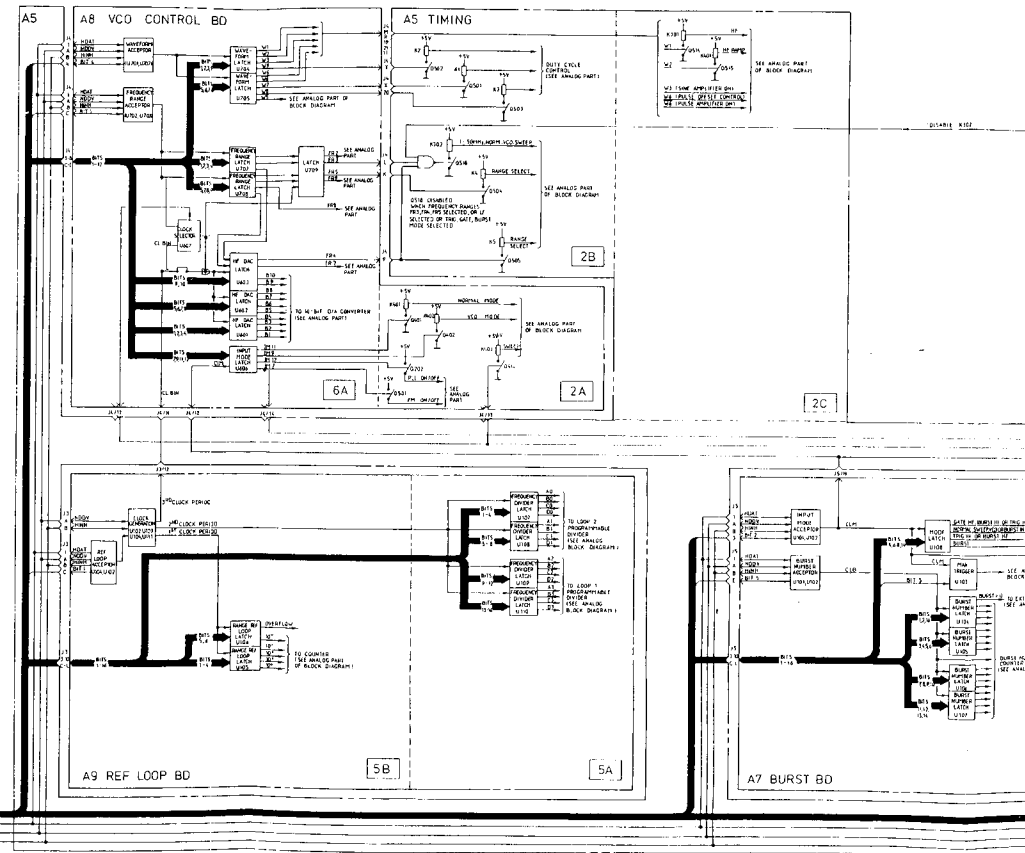
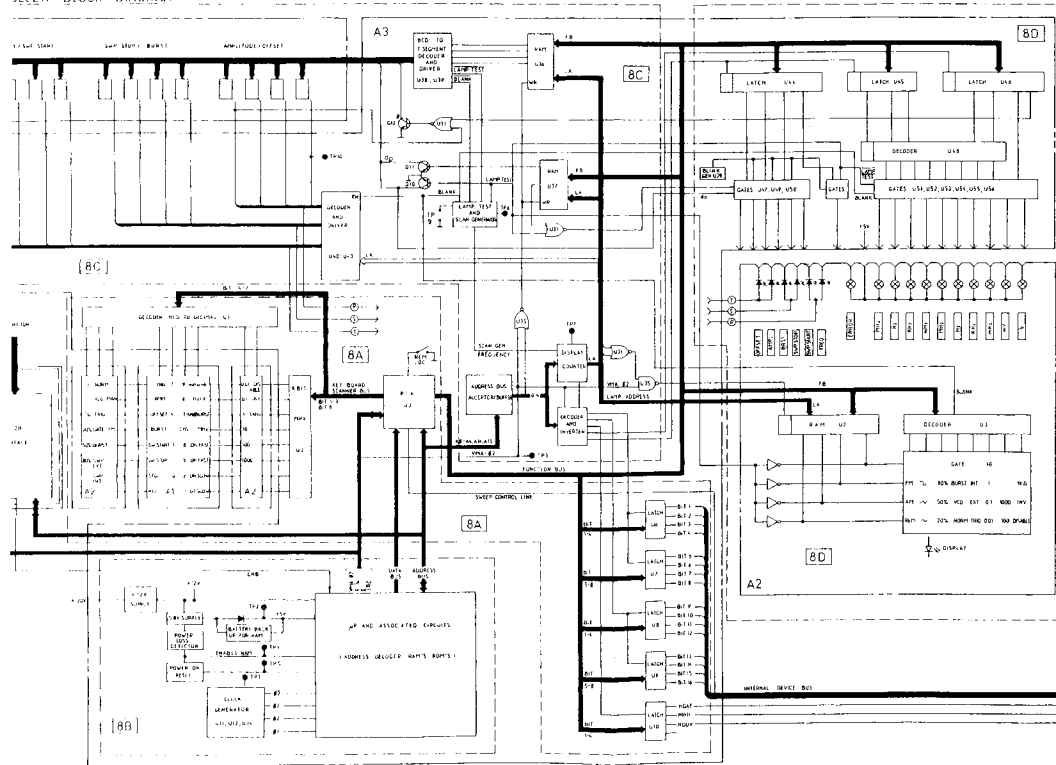
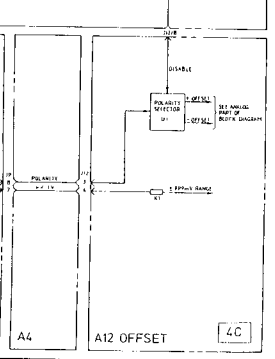
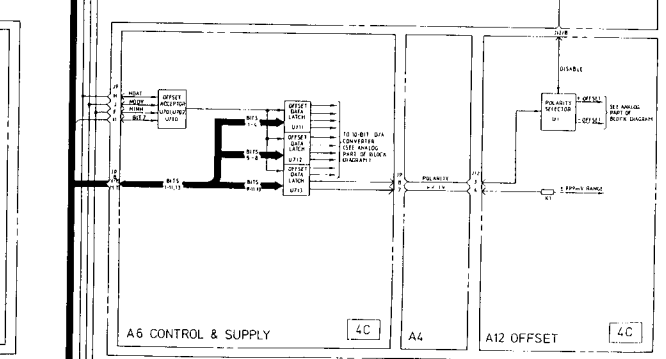
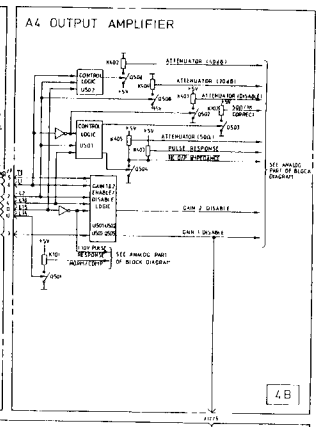
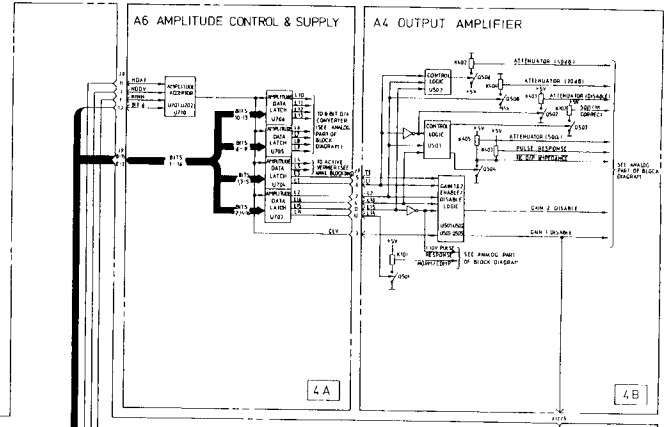
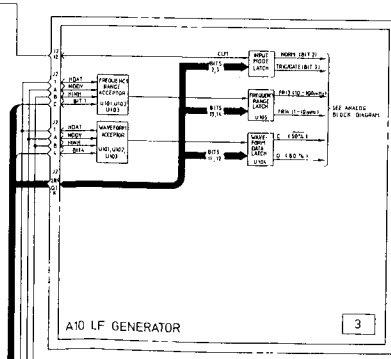
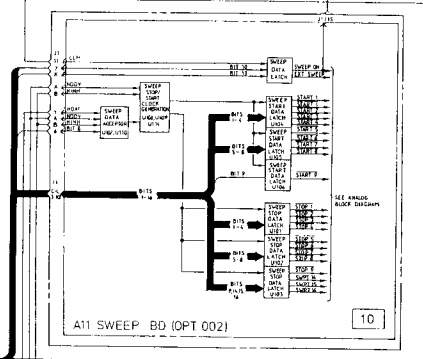
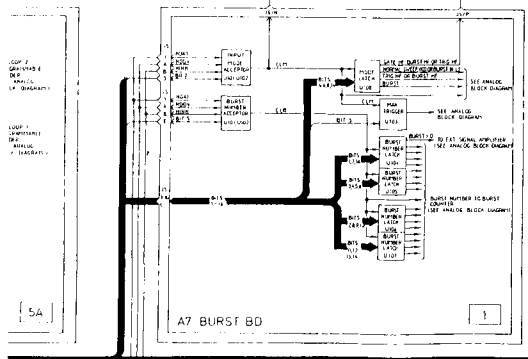
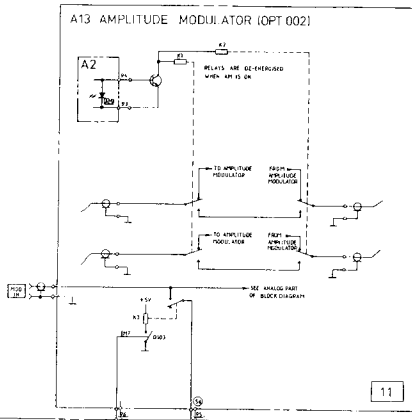
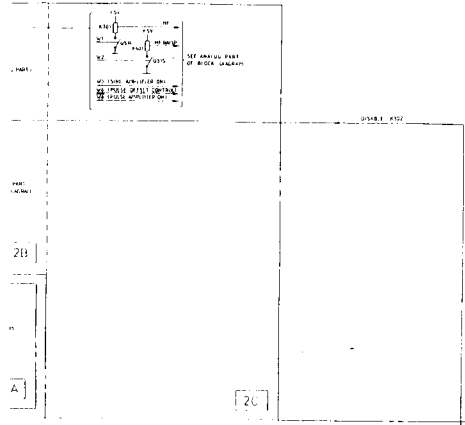

FIGURE 2 - TEN-BIT D/A CONVERTER BLOCK DIAGRAM



LLER BLOCK DIAGRAM





SERVICE BLOCK 1 TROUBLESHOOTING TREE

GENERAL

The purpose of this Service Block is to provide a fast fault-locating procedure. Having located the function at fault, detailed circuit operating theory and down-to-component troubleshooting hints are given for the function in one of the following Service Blocks. Details of which Service Block relates to which function are given in the following. Basically any 8165A malfunction can be categorized as follows:

1. Control-microprocessor with the device bus and related circuits.
Service Blocks dealing with this category are the Service Block 1 (device bus) and Service Block 5 (microprocessor).
2. Display/Keyboard – Service Block 5.
3. Any analog function block with its related device bus receiver.
Service Blocks belonging to this category are:
Service Block 2 (burst), Service Block 3 (frequency), Service Block 4 (output stage),
Service Block 5 (microprocessor and display), Service Block 7 (sweep), Service Block 8 (AM).

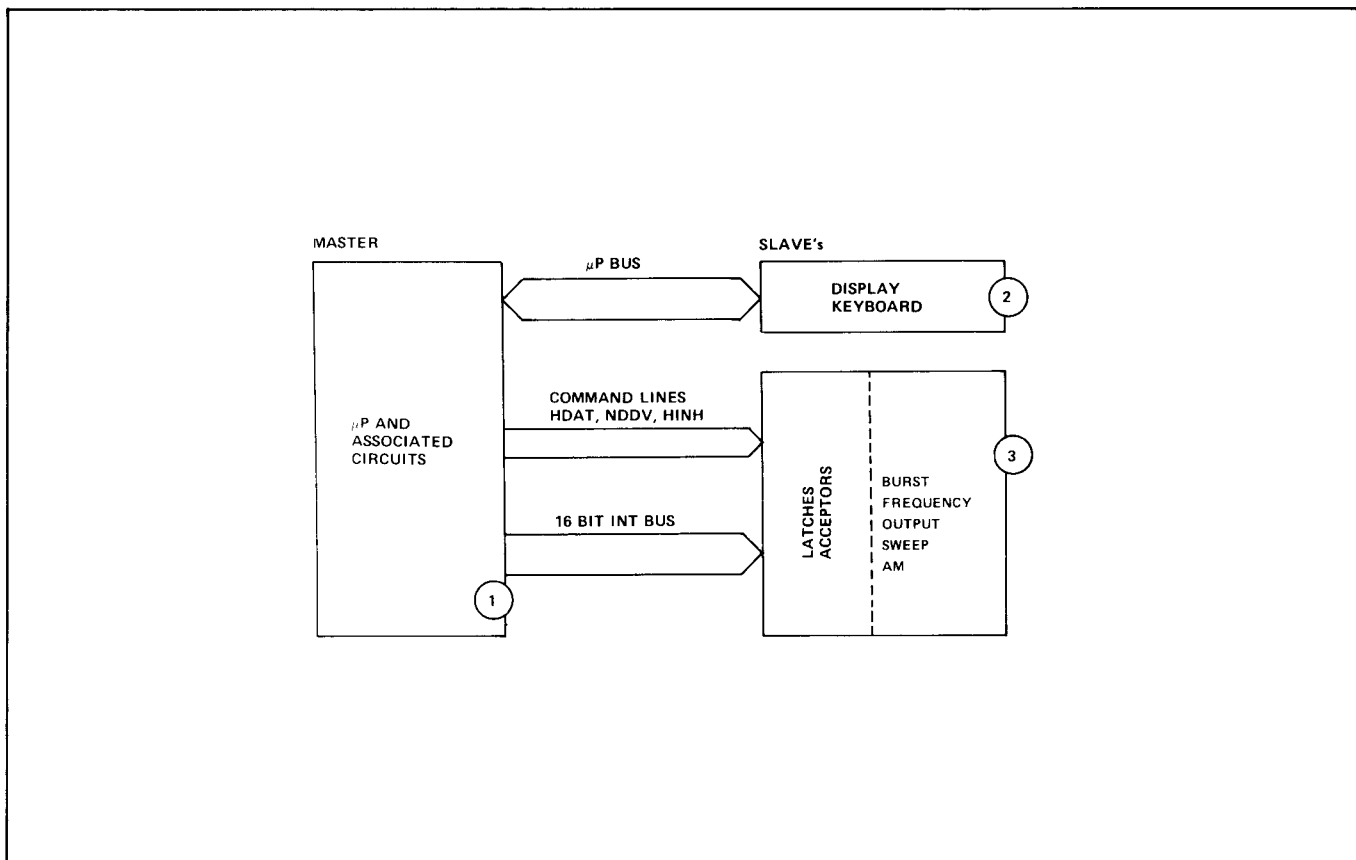

Figure 8-1-2. Categories of 8165A Malfunction

TROUBLESHOOTING

In order to locate the trouble, operate the 8165A via front panel or remotely, or together with the corresponding test equipment.

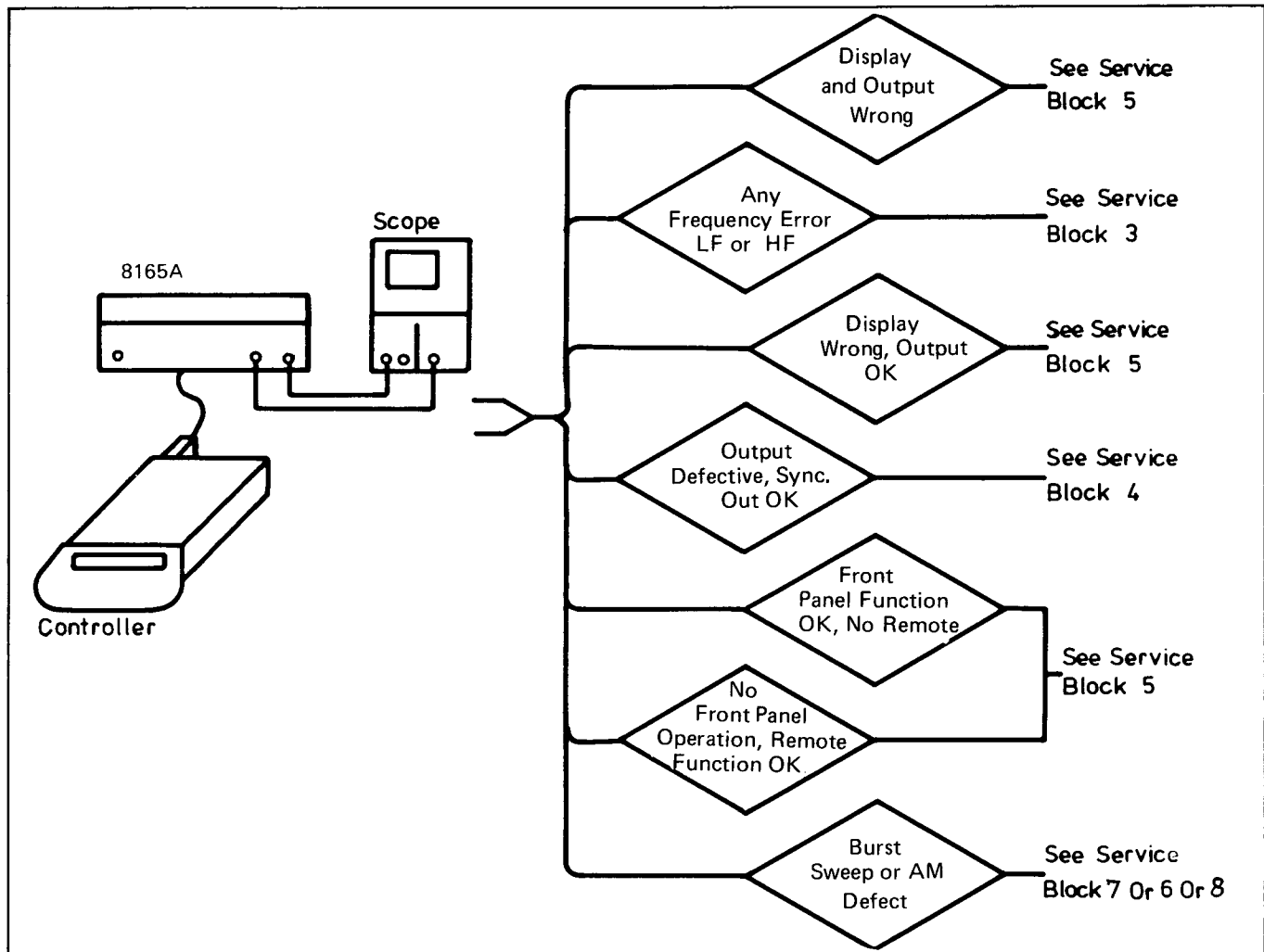

Figure 8-1-3. Troubleshooting Tree

INTERNAL DEVICE BUS DATA TRANSFER

GENERAL

The 8165A Block Diagram, Figure 8–1–1 shows the relationship between microprocessor and slaves (display and analog section).

This Service Block provides all the necessary information regarding the internal device bus in order to understand its function, and thus trace any trouble to the microprocessor or one of the related function blocks.

THEORY OF OPERATION

Microprocessor

The microprocessor is the data and instruction center of the 8165A Programmable Pulse Generator. It generates the control information required by the instrument dependent on inputs from one of two sources:

- a) Keyboard inputs when in manual control
- b) HP-IB inputs when in remote control.

During operation, inputs from one of these sources program the desired output parameters. These parameters are frequency, duty cycle, burst, amplitude, offset, sweep, FM, AM, the inputs modes and the output modes. When the instrument is in the remote control mode, the keyboard switches are disabled and output parameters can be entered only through the HP-IB.

For detailed troubleshooting information on the microprocessor itself – see SERVICE BLOCK 5.

Device Bus Acceptors

The receiver end of the 16-bit device bus comprises latches and address acceptors for each block (frequency etc.). The acceptor circuit recognizes its own address and generates the necessary load pulse(s) for loading data into the latches.

There are three control lines which handle the DATA/ADDRESS transfer and reset the acceptor circuits. These are as follows:

NDDV = NOT DATA VALID
HDAT = HIGH DATA
HINH = HIGH INHIBIT

Before any data transfer can take place, the HINH is pulled high so that all acceptor flip-flops are set, thus no address can be recognized nor data loaded. At this point, the HDAT line is low and the NDDV line is high (i.e. no valid data or addresses on the device bus).

Should the microprocessor now need to address a particular function block, it first pulls HINH and NDDV low, enabling each acceptor to recognize its unique address, and then sends the address on the device bus. The NDDV then goes high again while the acceptor flip-flop Q output goes low. The function block is now addressed.

With the address accepted, the HDAT line will go high to indicate that the next device bus transfer is data, which will be loaded by pulling NDDV low and then high again.

Typical examples of how device bus acceptors function are given in Figure 8-1-4 and 8-1-5. Figure 8-1-4 illustrates the generation of a single load pulse, while Figure 8-1-5 illustrates the generation of 3 load pulses.

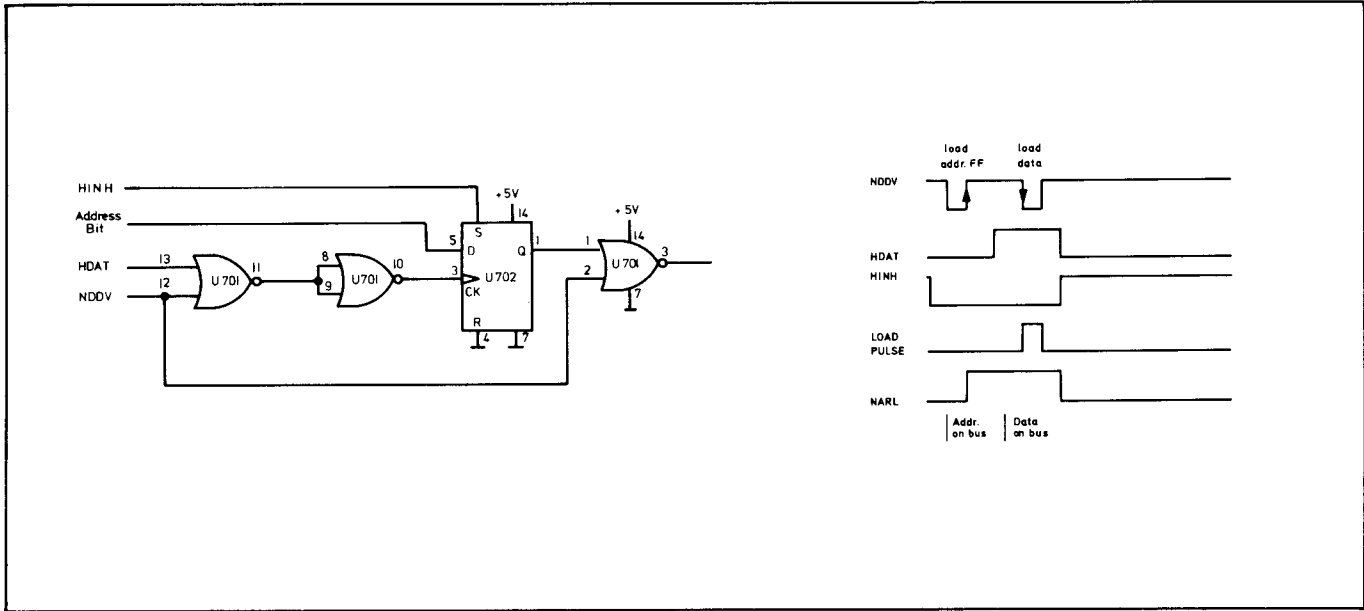

Figure 8-1-4. Device bus acceptor circuit (1 load pulse)

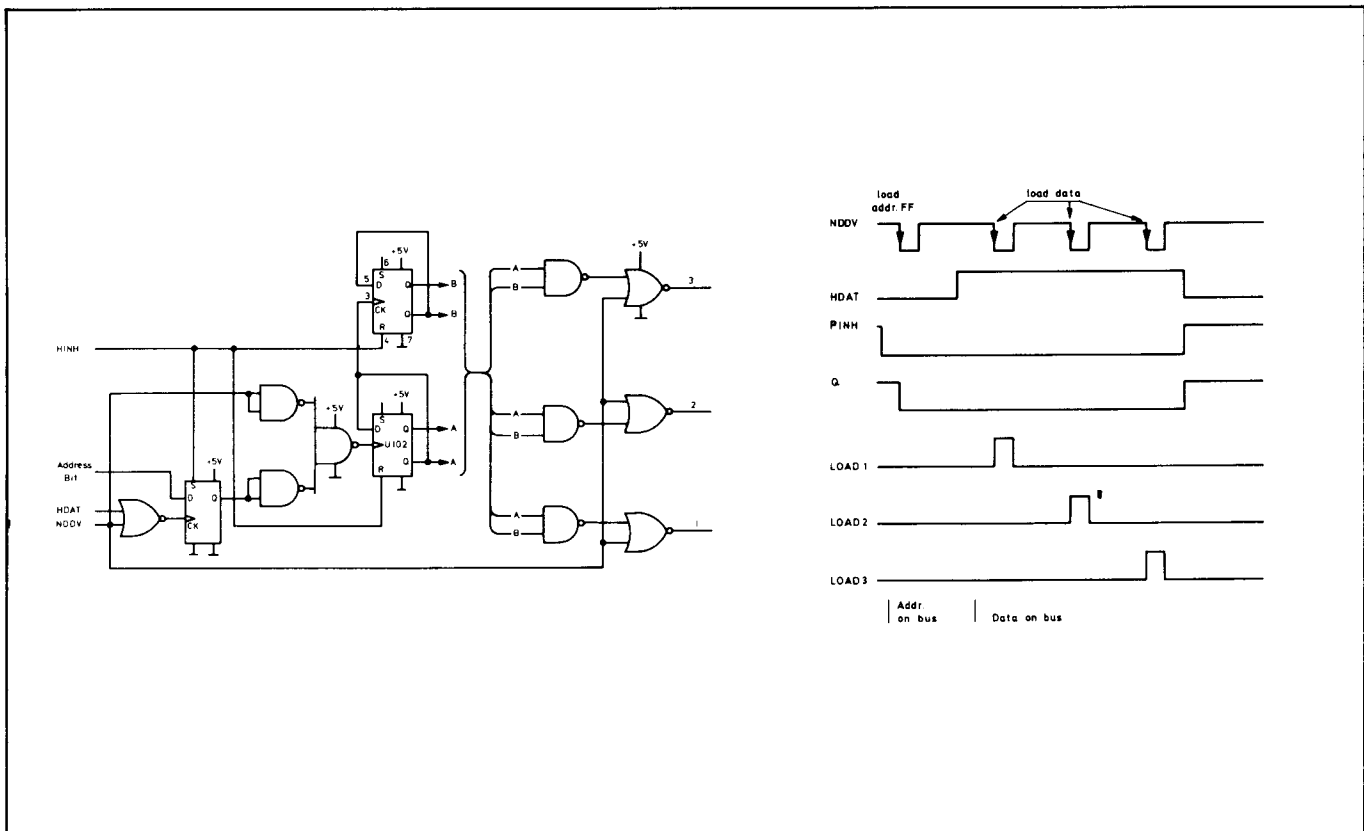

Figure 8-1-5. Device bus acceptor circuit (3 load pulses)

TROUBLESHOOTING

The following relates only to Device Bus troubleshooting. For troubleshooting information as the microprocessor and display see SERVICE BLOCK 5.

By using a Logic Analyzer, the complete data transfer from the microprocessor can be tested. First connect the Logic Analyzer via an extender board to the A3 device bus connector. Data transfer then takes place as soon as a MODE (FUNCTION/INPUT/OUTPUT) or ENTRY button has been pressed, the transfer comprising 2 or more data steps always beginning with the device address.

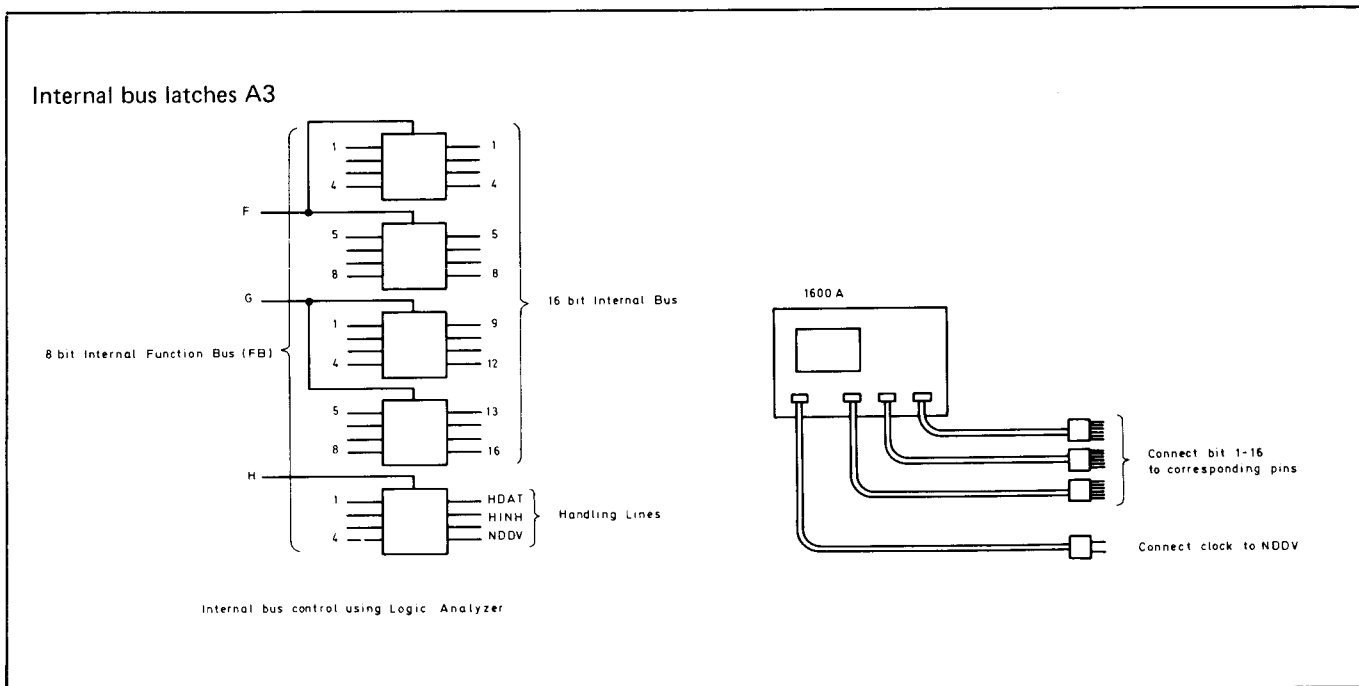

Figure 8-1-6. Device bus test set-up

Table 8-1-1. Internal Bus Device Addresses

bit	16	15	14	13	12	11	10	9	8	7	6	5	4	3	2	1		
	1	1	1	1	1	1	1	1	1	1	1	1	1	1	1	0	Frequency	bit 1
	1	1	1	1	1	1	1	1	1	1	1	1	1	1	0	1	Input Mode	bit 2
	1	1	1	1	1	1	1	1	1	1	1	1	0	1	1	1	Waveform	bit 4
	1	1	1	1	1	1	1	1	1	1	0	1	1	1	1	1	Burst	bit 5
	1	1	1	1	1	1	1	1	1	0	1	1	1	1	1	1	Amplitude	bit 6
	1	1	1	1	1	1	1	1	1	0	1	1	1	1	1	1	Offset	bit 7
	1	1	1	1	1	1	1	1	0	1	1	1	1	1	1	1	Sweep	bit 8

Table 8-1-2. Input Mode Data Transfer (8 step transfer)

	16	15	14	13	12	11	10	9	8	7	6	5	4	3	2	1	
	1	1	1	1	1	1	1	1	1	1	1	1	0	1	1	1	Waveform address
	x	x	x	x	x	x	x	x	x	x	x	x	x	x	x	x	Waveform data
	1	1	1	1	1	1	1	1	1	1	1	1	1	1	0	1	Input mode address
	x	x	x	x	x	x	x	x	x	x	x	x	x	x	x	x	Input mode data
	1	1	1	1	1	1	1	1	1	1	1	1	1	1	1	0	Frequency address
	x	x	x	x	x	x	x	x	x	x	x	x	x	x	x	x	Frequency data
	x	x	x	x	x	x	x	x	x	x	x	x	x	x	x	x	Frequency data
	x	x	x	x	x	x	x	x	x	x	x	x	x	x	x	x	Frequency data
	data only shown																
	0	0	1	1	0	0	0	FM1	1				x	0	1		Norm HF
	0	0	1	1	0	0	0		1	1			x	0	1		Norm LF
	0	0	0	1	0	0	0		0	1			0	1	0		Gate HF
	0	0	1	1	0	0	0		1	1			0	1	0		Gate LF
	0	0	0	1	0	0	1		0	MT			1	1	0		Trigger HF
	0	0	1	1	0	0	0		1	MT			1	1	0		Trigger LF
	1	0	0	1	0	0	1		0	MT			1	1	0		Burst HF
	1	0	1	1	0	0	0		1	MT			0	1	0		Burst LF
	0	0	x	0	1	0	0		1	1			x	0	0		Sweep int
	0	1	x	0	1	0	0		1	MT			0	0	0		Sweep ext
	0	0	x	0	0	1	0		1	1			x	0	0		VCO
IM 14	└───┘																
IM 13	└───┘																
IM 12	└───┘																
IM 11	└───┘																
								IM 9									IM 5
								IM 10									IM 6
																	IM 7
																	IM 8
																	not used
																	IM 2
																	IM 3

Table 8-1-3. Input Mode Data Function

Mnem.	Mode — Description	bits used
IM 6	enables ext. inputs and VCO in all modes except Gate HF, Trigger HF, Burst HF	6
IM 11	activates relay K401 in all modes except sweep, VCO	11
IM 12	enables PLL (Q202) in norm and all LF modes	12
IM 9	enables VCO via K402	9
IM 8	changes ext. input to differ between Trig and Gate	8
IM 3, 2	enables LF Generator (IM 3 and IM 2) as trigger mode. LF Generator is used only in LF mode	2,3
IM 2	enables LF Generator as gate mode. LF Generator is used only in LF mode.	2
IM 14	Burst enable	14
IM 13	enables Sweep extern	13
IM 10	enables Sweep intern	10
IM 5	Manual trigger (MT = 0) Amplitude modulation is taken from AM LED.	5
IM 7	Frequency modulation (FM = 1)	7

Table 8-1-4. Waveform Data Transfer (2 Step Transfer)

bit	16 15 14 13	12 11 10 9	8 7 6 5	4 3 2 1	
	1 1 1 1	1 1 1 1	1 1 1 1	0 1 1 1	Waveform address
	x x x x	x x x x	x x x x	x x x x	Waveform data
					only data shown
	not used	0 0 1 0	0 1 0 0	x 1 0 0	Sine HF (1 KHz)
	x x x x	0 0 1 0	0 1 0 0	x 1 0 1	Sine LF (999 Hz)
		0 0 1 0	0 1 0 0	x 0 1 1	Triangle HF 50%
		0 0 1 0	0 1 0 1	x 0 0 1	Triangle LF 50%
		1 1 1 1	0 0 0 0	x 0 1 1	Ramp HF 20/80
		0 1 1 0	0 1 0 1	x 0 0 1	Ramp LF 20/80
		0 1 1 1	1 1 0 0	x 0 1 1	Ramp HF 80/20
		1 1 1 0	0 1 0 1	x 0 0 1	Ramp LF 80/20
		x 0 0 0	0 1 1 0	x 0 0 x	Pulse HF 50%
		x 0 0 0	0 1 1 0	x 0 0 x	Pulse LF 50%
		0 1 0 1	0 0 1 0	x 0 0 x	Pulse HF 80/20
		0 1 0 0	0 1 1 0	x 0 0 x	Pulse LF 80/20
		1 1 0 1	1 1 1 0	x 0 0 x	Pulse HF 20/80
		1 1 0 0	0 1 1 0	x 0 0 x	Pulse LF 20/80
			1 1 0		If 20 MHz – 50 MHz Range

	W ₁₂ W ₁₁ W ₁₀ W ₉	W ₈ W ₇ W ₆ W ₅	W ₃ W ₂ W ₁	
LF duty cycle	_____	_____	_____	Sine LF/HF select
Pulse ampl. on/off	_____	_____	_____	Enable HF ramp
VCO ramp (K1)	_____	_____	_____	Sine enable
VCO ramp (K3)	_____	_____	_____	LF Ramp enable
VCO ramp (K2)	_____	_____	_____	Pulse offset

Table 8-1-5. Duty Cycle De-coding

Triangle	1 kHz to 19.99 MHz			20 MHz - 50 MHz		
	K1	K2	K3	K1	K2	K3
20%						
50%						
80%						
Pulse						
20%						
50%						
80%						

Table 8-1-6. Amplitude Data Transfer

bit	16	15	14	13	12	11	10	9	8	7	6	5	4	3	2	1	
	1	1	1	1	1	1	1	1	1	0	1	1	1	1	1	1	Amplitude address
	x	x	x	x	x	x	x	x	x	x	x	x	x	x	x	x	Amplitude data
	1	1	1	1	1	1	1	1	1	0	1	1	1	1	1	1	Offset address
	x	x	x	x	x	x	x	x	x	x	x	x	x	x	x	x	Offset data data only shown
	0	1	0	0	0	0	0	0	0	0	0	0	0	0	0	0	999 mV
	0	0	0	0	0	0	0	0	0	0	0	1	1	1	1	0	1.99 V
	0	0	0	0	1	1	0	0	0	1	1	1	0	0	1	0	5.00 V
	0	0	0	0	0	0	0	1	0	0	1	0	0	0	1	0	9.90 V
	D/A conv. data												current sources I_B, I_C			} output mode data	
	Active Vernier data												Gain 2				
	Norm/Compl.																
	disables Output for about 5 ms, will be 1 when L_1, L_2, L_{14}, L_{15} changes.																

Table 8-1-7. Amplitude D/A Converter Data

NOTE: Digital step size between 1 V (100 mV) and 1.99 V (199 mV) is 2; this means LSB (9) is not used. (99 steps only, output gain X1).

Digital step size between 2 V (200 mV) and 3.99 V (399 mV) is 1; this means LSB (9) is used. (199 steps now, output gain X2). Valid for all ampl. ≥ 2 V.

Digital step size between 10 V and 19.9 V is 5; this means 100 mV amplitude change.

DISPLAY AMPLITUDE	D/A Converter Logic						Vernier Outp. TP2
	L ₁₃	L ₁₂ L ₁₁ L ₁₀ L ₉	L ₈ L ₇ L ₆				
1.00 V (100 mV, 10 mV)	1	1 0 0 0	1 1 0				≈ 1.00 V
1.10 V (110 mV, 11 mV)	1	0 1 1 0	0 1 0				≈ 1.10 V
1.20 V (120 mV), 12 mV)	1	0 0 1 1	1 1 0				≈ 1.20 V
1.34 V(134 mV,13,4mV)	1	0 0 0 0	0 1 0				≈ 1.34 V
1.35 V(135 mV,13,5mV)	1	0 0 0 0	0 0 0				≈ 1.35 V
1.96 V(196 mV,19,6mV)	0	0 0 0 0	1 1 0				≈ 1.96 V
1.97 V(197 mV,19,7mV)	0	0 0 0 0	1 0 0				≈ 1.97 V
1.98 V(198 mV,19,8mV)	0	0 0 0 0	0 1 0				≈ 1.98 V
1.99 V(199 mV,19,9mV)	0	0 0 0 0	0 0 0				≈ 1.99 V

Table 8-1-8. Complete Amplitude Data (50 Ω / 50 Ω)

DISPLAY AMPLITUDE	Vernier Output A4 TP2		Current sources		Gain 2
			IB	IC	
			bit 5	bit 4	bit 3
1 V – 1.99 V (100 mV – 199 mV), (10 mV – 19 mV)	≈	1 V – 1.99 V	1	1	0
2 V – 3.99 V (200 mV – 399 mV), (20 mV – 39 mV)	≈	1 V – 1.99 V	1	1	1
4 V – 5.99 V (400 mV – 599 mV), (40 mV – 59 mV)	≈	2 V – 2.99 V	1	0	1
6 V – 7.99 V (600 mV – 799 mV), (60 mV – 79 mV)	≈	3 V – 3.99 V	0	1	1
8 V – 9.99 V (800 mV – 999 mV), (80 mV – 99 mV)	≈	4 V – 4.99 V	0	0	1

Table 8-1-9. Output Mode Data

Attenuator	Imped.	bit 1	bit 2	bit 15
Outp. disable	50 Ω	1	1	0
0 dB	1 KΩ	0	1	1
0 dB	50 Ω	0	1	0
20 dB	50 Ω	0	0	1
40 dB	50 Ω	1	1	1

Phase	bit 14
NORM	0
INV	1

Table 8-1-10. Offset Data

bit	16	15	14	13	12	11	10	9	8	7	6	5	4	3	2	1	
	1	1	1	1	1	1	1	1	1	0	1	1	1	1	1	1	address } OFFSET data } +100 mV
	0	0	0	0	0	0	0	0	0	1	1	0	0	1	0	address } AMPLITUDE data }	
	1	1	1	1	1	1	1	1	1	1	0	1	1	1	1		address data + 5V (= 500)
	0	0	0	1	1	0	0	0	1	1	0	1	1	1	0		
					D/A Converter data												
					10 mV – 999 mV = 0; > 1 V = 1												
					polarity 1 = NEG; 0 = POS												

Table 8-1-11. Sweep Mode Data Transfer

Sweep mode data are transferred with input mode data.

bit	16	15	14	13	12	11	10	9	8	7	6	5	4	3	2	1	
	1	1	1	1	1	1	1	1	1	1	1	1	0	1	1	1	Waveform address Waveform data
	x	x	x	x	x	x	x	x	x	x	x	x	x	x	x	x	
	1	1	1	1	1	1	1	1	1	1	1	1	1	1	0	1	Input mode address Input mode data
	x	x	x	x	x	x	x	x	x	x	x	x	x	x	x	x	
	1	1	1	1	1	1	1	1	1	1	1	1	1	1	1	0	Frequency address Frequency data Frequency data Frequency data
	x	x	x	x	x	x	x	x	x	x	x	x	x	x	x	x	
	x	x	x	x	x	x	x	x	x	x	x	x	x	x	x	x	
	x	x	x	x	x	x	x	x	x	x	x	x	x	x	x	x	

Table 8-1-12. Sweep Mode

Bit	Sweep Ext.	Sweep Int.	No Sweep
Bit 10	1	1	0
Bit 13	1	0	x

Table 8-1-13. Sweep Start/Stop Data Transfer

bit	16 15 14 13	12 11 10 9	8 7 6 5	4 3 2 1	
	1 1 1 1	1 1 1 1	0 1 1 1	1 1 1 1	Sweep address
	x x x x	x x x x	x x x x	x x x x	Sweep stop data
	x x x x	x x x x	x x x x	x x x x	Sweep start data
	1 1 1 1	1 1 1 1	1 1 1 1	0 1 1 1	Waveform address
	x x x x	x x x x	x x x x	x x x x	Waveform data
	1 1 1 1	1 1 1 1	1 1 1 1	1 1 0 1	Input mode address
	x x x x	x x x x	x x x x	x x x x	Input mode data
	1 1 1 1	1 1 1 1	1 1 1 1	1 1 1 0	Frequency address
	x x x x	x x x x	x x x x	x x x x	Frequency data first set only

The STOP frequency determines (via μP) which VCO time constant will be selected

Bit 1 to 9 transfers start and stop data

Table 8-1-14. Start/Stop Data

bit	9 8 7 6 5 4 3 2 1	decimal	V Sweep out	V anti log out
	0 0 0 0 0 0 0 0 0	0	3.00 V	0.01 V
	0 0 1 0 1 0 1 0 1	85	2.50 V	0.0316 V
	0 0 1 1 1 0 1 1 1	119	2.3 V	0.0501 V
	0 1 0 0 1 1 0 0 1	153	2.1 V	0.0794 V
	0 1 0 1 0 1 0 1 0	170	2.00 V	0.1 V
	0 1 1 0 0 1 1 0 0	204	1.8 V	0.158 V
	0 1 1 1 1 1 1 1 1	255	1.5 V	0.316 V
	1 0 0 1 0 0 0 0 1	289	1.3 V	0.501 V
	1 0 1 0 0 0 0 1 1	323	1.1 V	0.794 V
	1 0 1 0 1 0 1 0 0	340	1.0 V	1.0 V
	1 0 1 1 1 0 1 1 0	374	0.8 V	1.585 V
	1 1 0 1 0 1 0 0 1	425	0.5 V	3.162 V
	1 1 1 0 0 1 0 0 0	456	0.3 V	5.01 V
	1 1 1 1 0 1 1 1 0	494	0.1 V	7.94 V
	1 1 1 1 1 1 1 1 1	511	0 V	10.0 V

Bit 10 of the F_D Counter will be set with load

Table 8-1-15. Sweep Time Data Transfer

bit	16 15 14 13	12 11 10 9	8 7 6 5	4 3 2 1	
	1 1 1 1	1 1 1 1	0 1 1 1	1 1 1 1	Sweep address Sweep time data
	x x x x	x x x x	x x x x	x x x x	
	sweep time data		stop - data		

Table 8-1-16. Sweep Time Data

bit	16 15 14	Sweep time	Clock freq.
	0 0 0	1 ms / decade	34.1 KHz
	0 0 1	10 ms / decade	3.41 KHz
	0 1 0	100 ms / decade	341 Hz
	0 1 1	1 s / decade	34.1 Hz
	1 0 0	10 s / decade	3.41 Hz
	1 0 1	100 s / decade	0.341 Hz

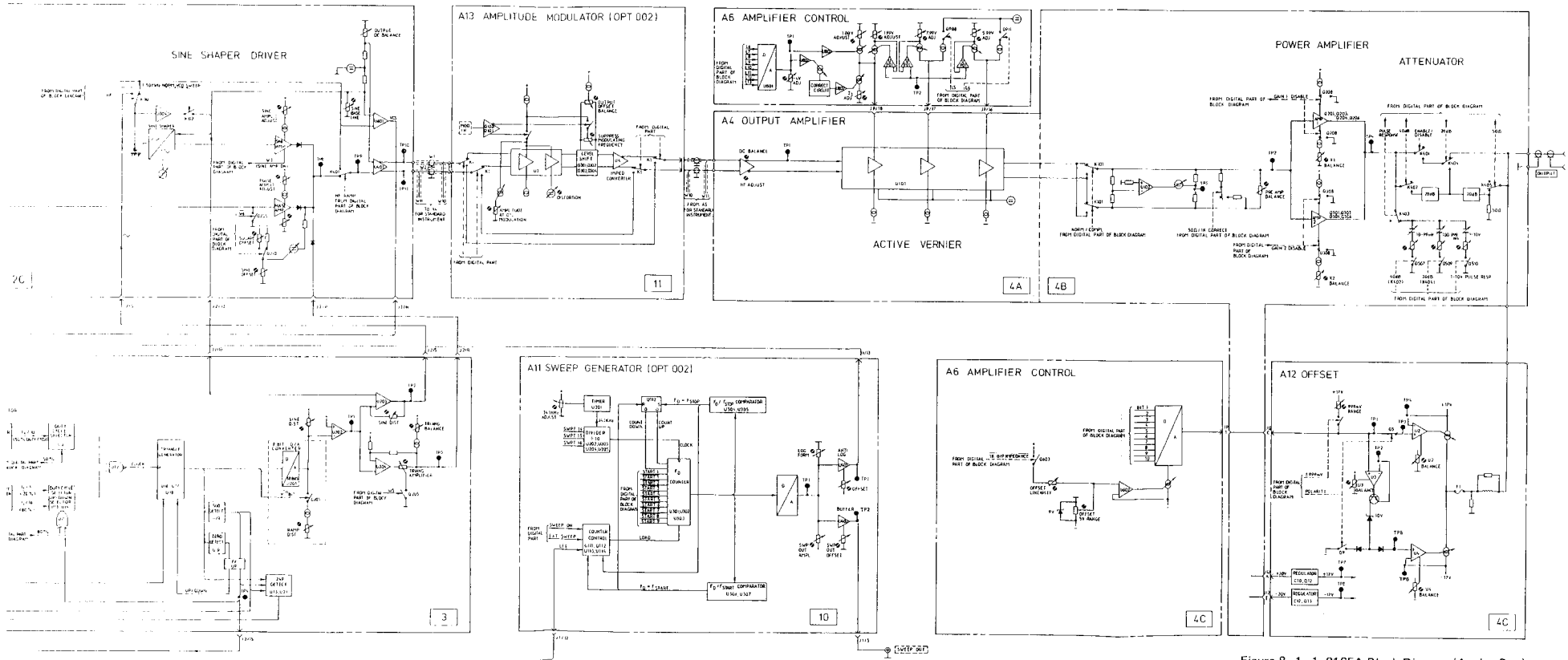
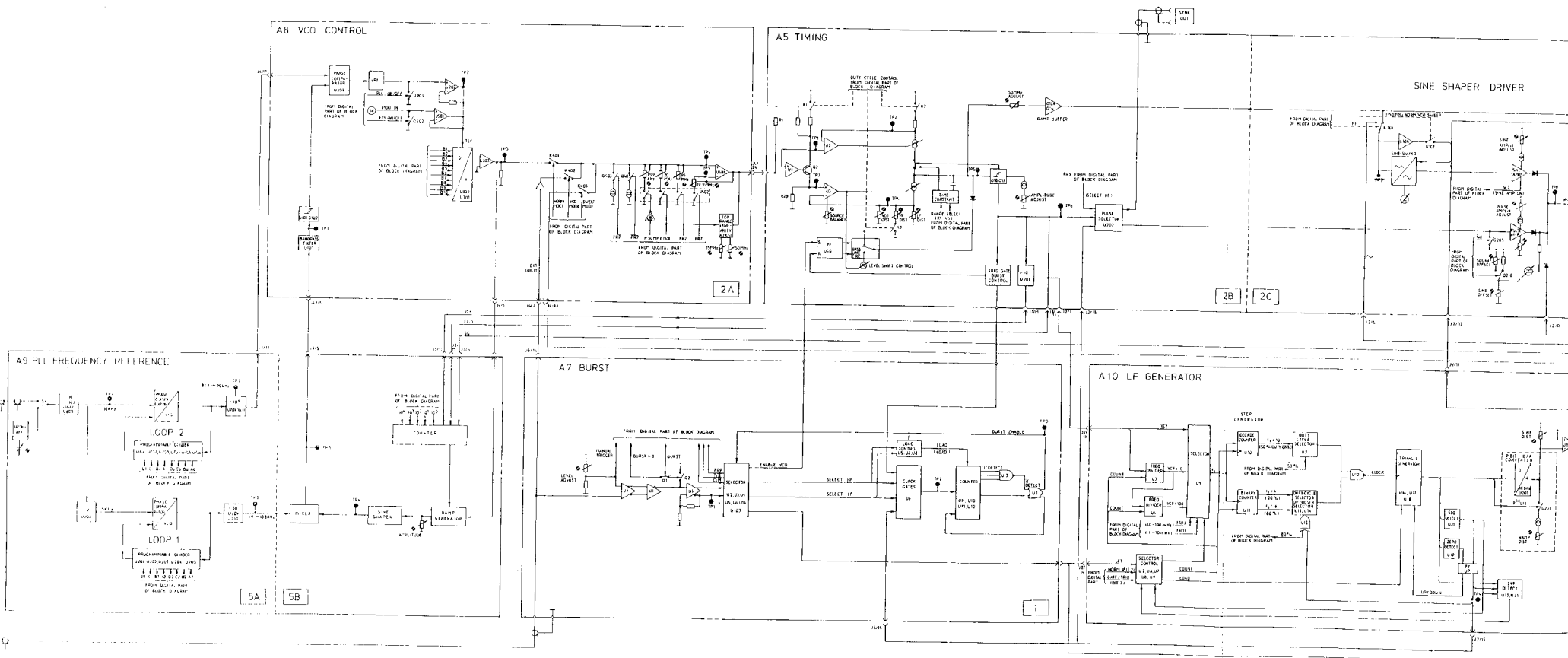
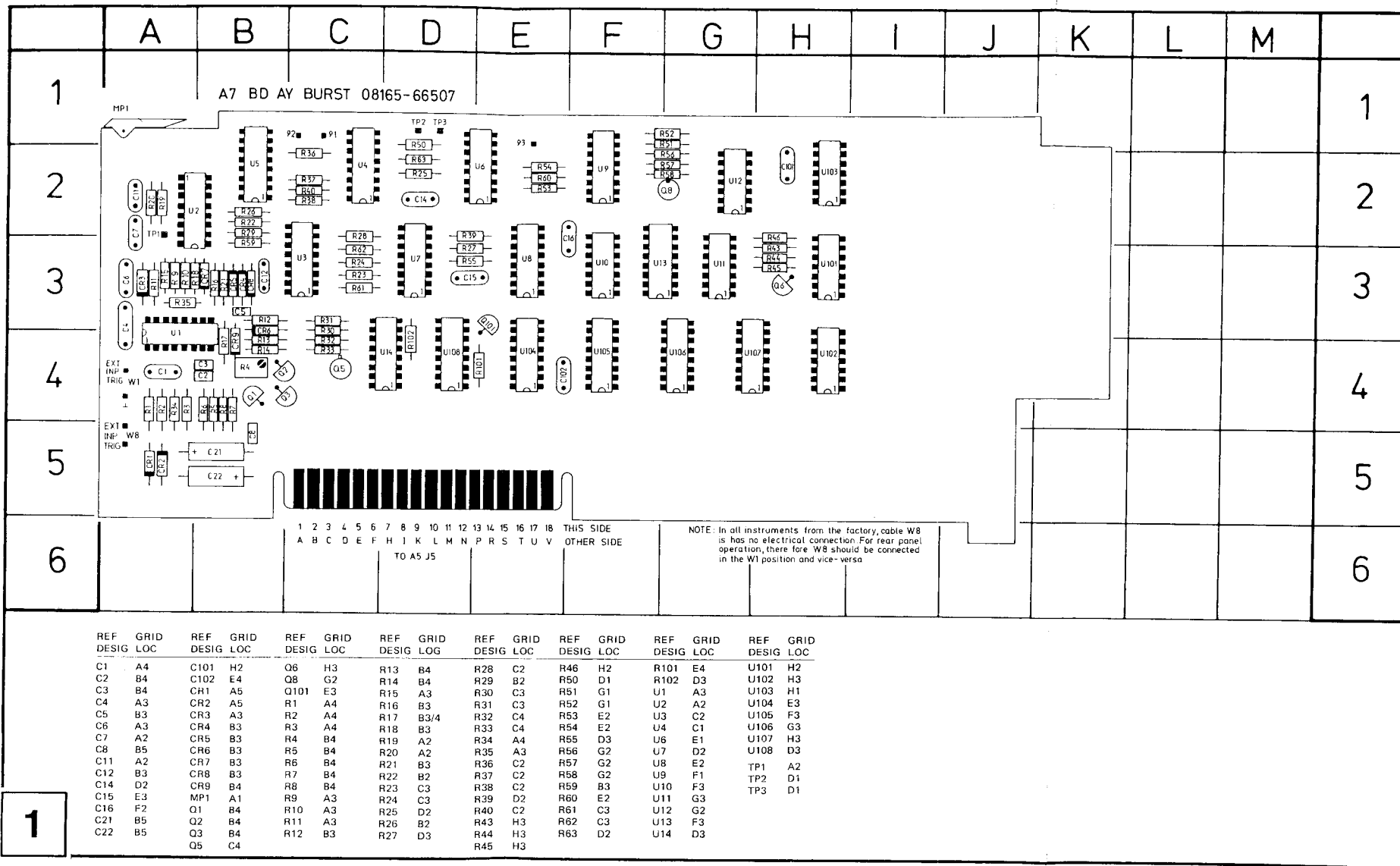

Figure 8-1-1. 8165A Block Diagram (Analog Part)





SERVICE BLOCK 2 BURST GENERATOR A7

1

THEORY OF OPERATION

To obtain a counted burst, a counter is necessary to stop the VCO/LFG (low frequency generator) after the required number of pulses has been generated. (The burst generator of the 8165A operates for any given burst number between 1 and 9999 at all period settings). Should the burst number be re-programmed during the burst, the burst is interrupted, and the burst counter reset. The counter must then be re-triggered for the new burst.

A block diagram of the burst generator is given in Figure 8–2–1. The burst generator consists of an acceptor circuit, a number of latches for the burst length data, a reset circuit and a binary up counter.

When the burst generator is programmed, the TTL section of the counter (U10, U11, U12) is set to a number 'M-(N-3)', whereby 'M' is the highest possible programmable number, and 'N' is the programmed burst number. After a trigger pulse sets the burst flip-flop U4 (pin 5 when frequency 1 mHz – 999 Hz; pin 12 when frequency 1 kHz – 50 MHz), the VCO/LFG is turned on and the burst counter counts up to 'M-3'. At the 'M-3' count the U13/pin 9 output goes low, and, at 'M-1' the U9/pin 14 also goes low. At 'M-1' therefore, the U13/pin 9 output puts a low on the D inputs (pins 7 and 10) of the burst flip-flop U4. The positive transition of the next pulse then clocks the burst flip-flop thus shutting of the VCO/LFG and resetting the counter. Figure 8–2–2 provides a timing diagram of the burst generator.

TROUBLESHOOTING

Check following conditions in order to get correct function:

1. Test MODE condition as in table 8–2–1.
2. Test correct data transfer as in table 8–2–2.
3. Check if the malfunction is in the LF (≤ 999 Hz) or in the HF (≥ 1 kHz) part or if both are defect.
4. In order to enable the VCO for a HF Burst (≥ 1 kHz) the ENABLE VCO signal must be high.
In order to enable the LF Generator for a LF Burst (≤ 999 Hz) the Low Frequency Trigger (LFT) must be low and the ENABLE VCO must be high.

Note: ECL and TTL components are combined in this circuit.

Typical ECL level
in this circuit



Waveforms for HF and LF function are shown at the end of this Service Block.

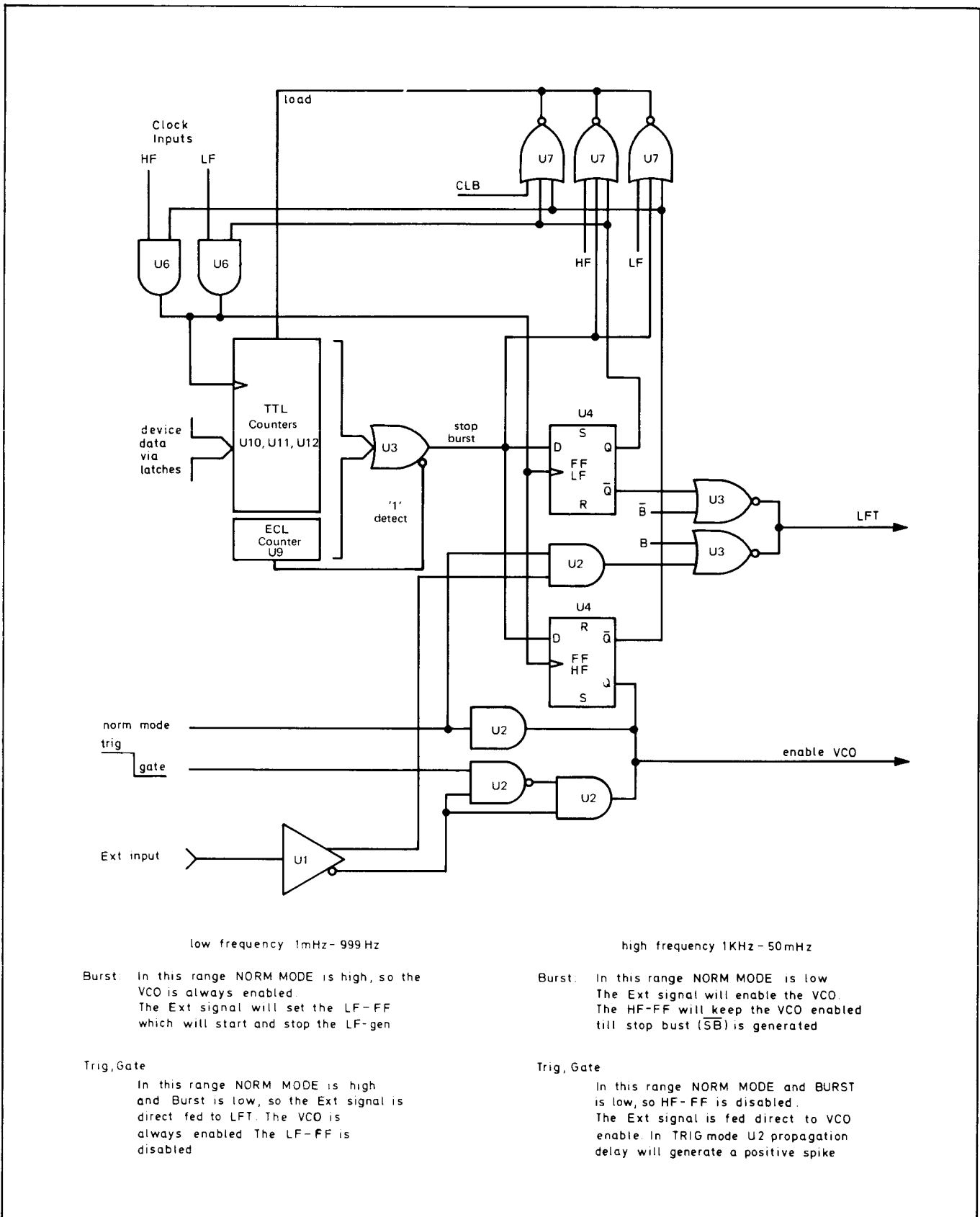

Figure 8-2-1. Burst Generator Block Diagram

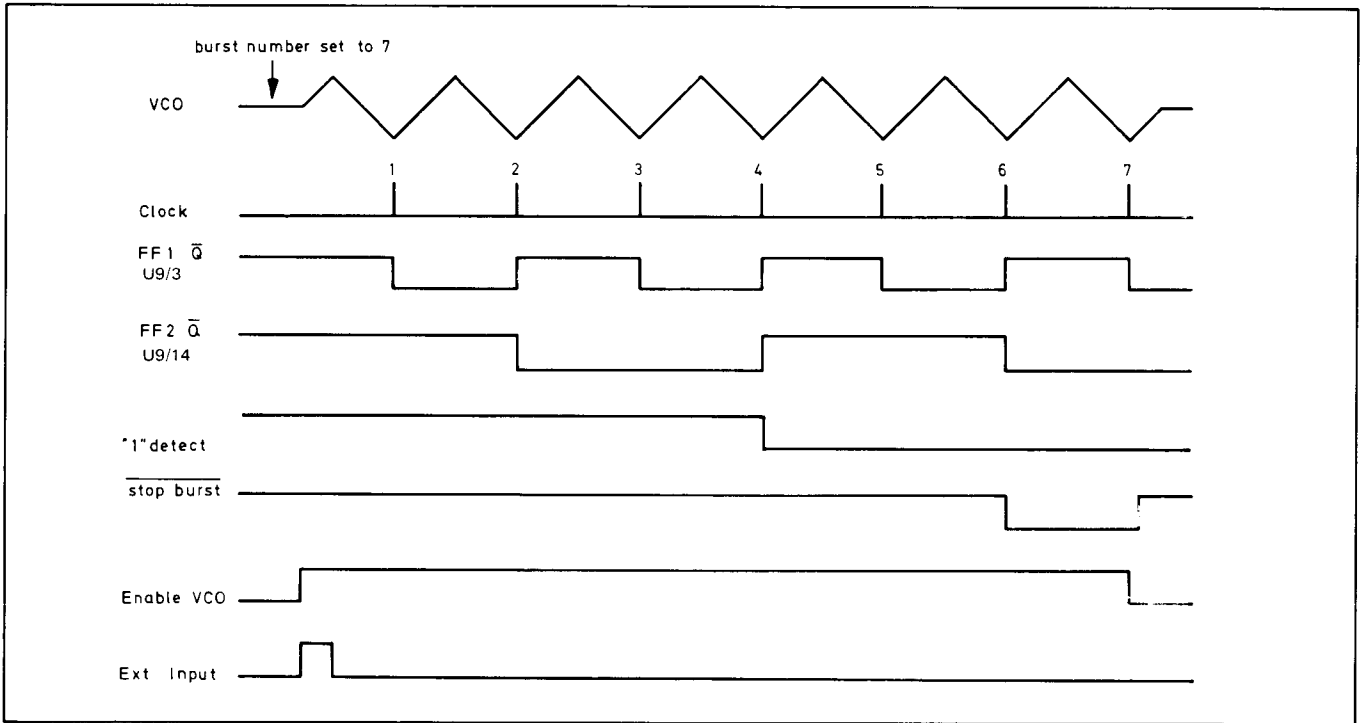

Figure 8-2-2. Burst Timing Diagram

Table 8-2-1. Input Mode Table

	NORM		GATE		TRIGGER		BURST		SWEEP		VCO
	HF	LF	HF	LF	HF	LF	HF	LF	EXT	INT	
U108	HF	LF	HF	LF	HF	LF	HF	LF	EXT	INT	
Q1 (bit 8)	0	0	0	0	1	0	1	0	0	0	0
Q2 (bit 6)	1	1	0	1	0	1	0	1	1	1	1
Q3 (bit 14)	0	0	0	0	0	0	1	1	0	0	0

LF (bit 9) indicates HF or LF and will be low if LF (≤ 999 Hz) and high if HF (≥ 1 kHz).

Table 8-2-2. Burst Data Transfer

U104 pin 15	U107 12 9 15 3	U106 12 9 15 3	U105 12 9 15 3	U104 9 3	number of burst
0	1 1 1 1	1 1 1 1	1 1 1 1	1 1	0
1	1 1 1 1	1 1 1 1	1 1 0 1	0 1	10
1	1 1 1 1	1 1 0 1	1 1 1 1	1 1	128
1	0 1 1 0	0 0 1 1	1 1 0 0	0 0	9999

Waveform condition BURST (LF)
8165A settings: FRQ 999 Hz, Ext source
200 Hz, BURST set to 4

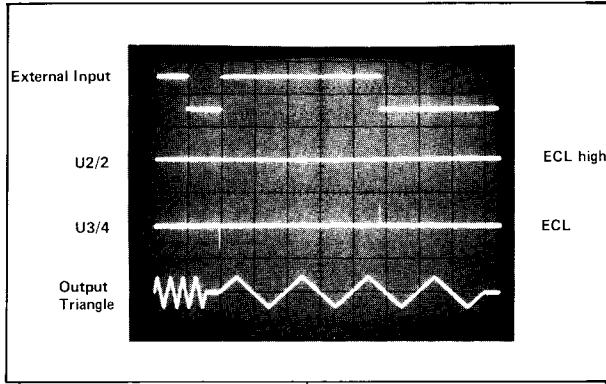

Waveform condition BURST (HF)
8165A settings: FRQ 500 kHz, Ext source 60 kHz,
BURST set to 4

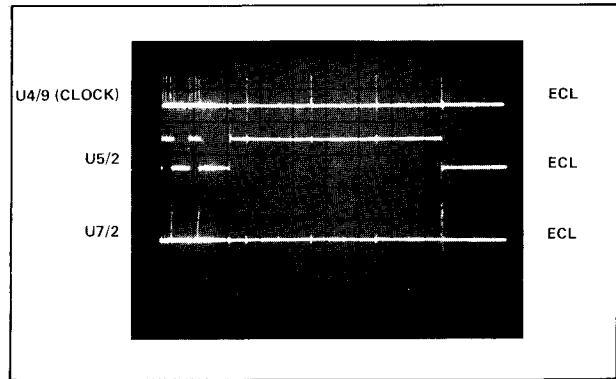
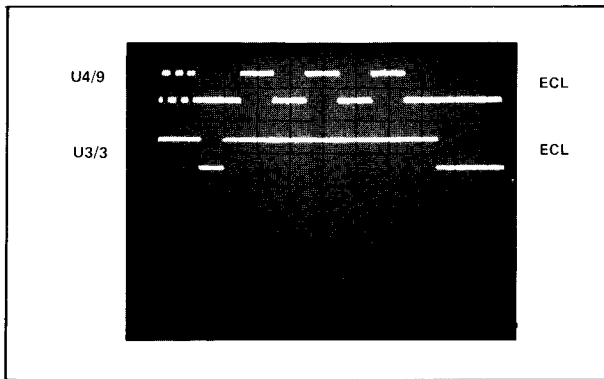
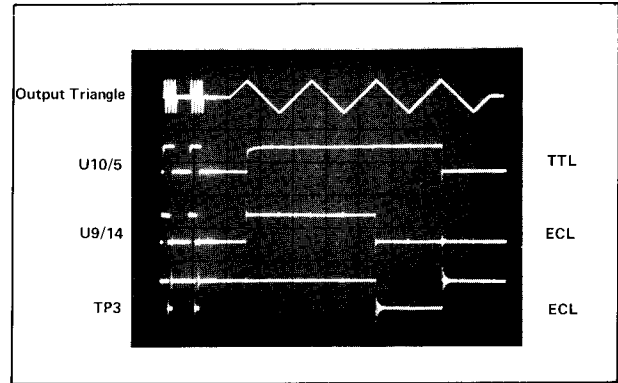
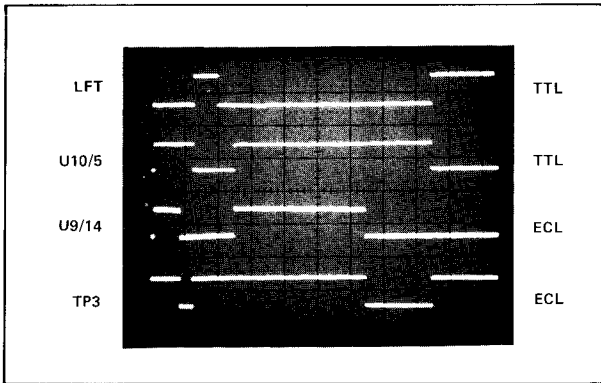
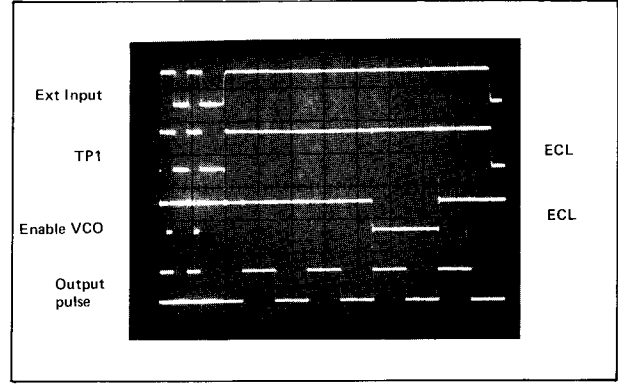

**Input Mode Acceptor
(all signals TTL)**

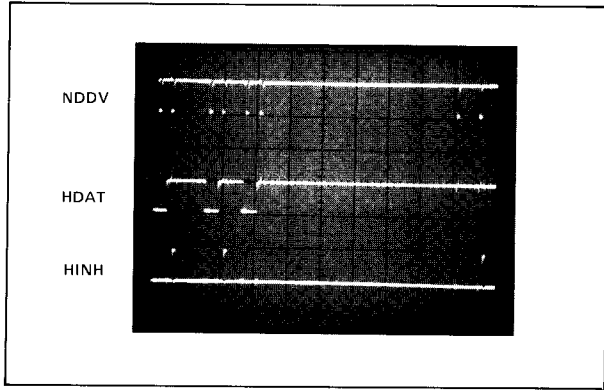

**Burst Mode Acceptor
(all signals TTL)**

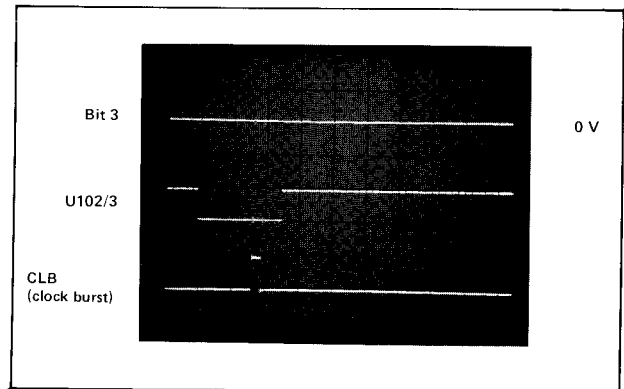
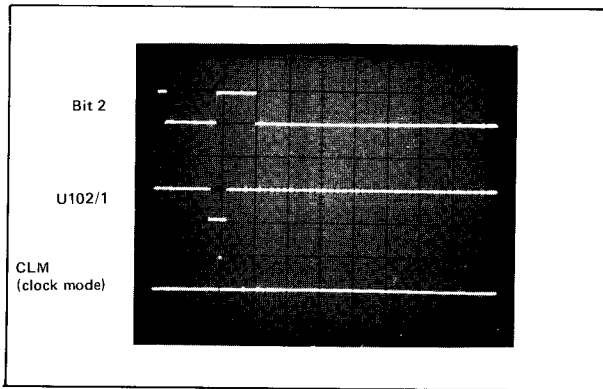
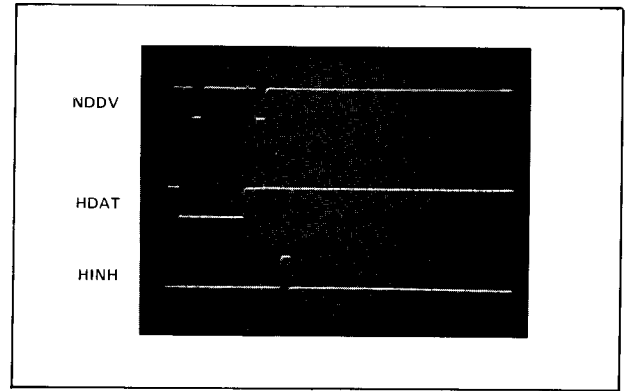

For repeating signals a controller is needed.
Program: wrt 716, "I5"; jmp 0
For device bus details see SERVICE BLOCK 1.

For repeating signals a controller is needed.
Program: wrt 716, "BUR 5 BT"; jmp 0
For device bus details see SERVICE BLOCK 1.

External Trigger

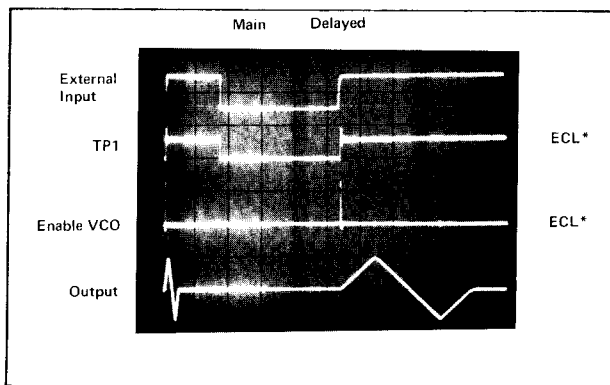

*Note ECL Level (3.2 V – 4.3 V)

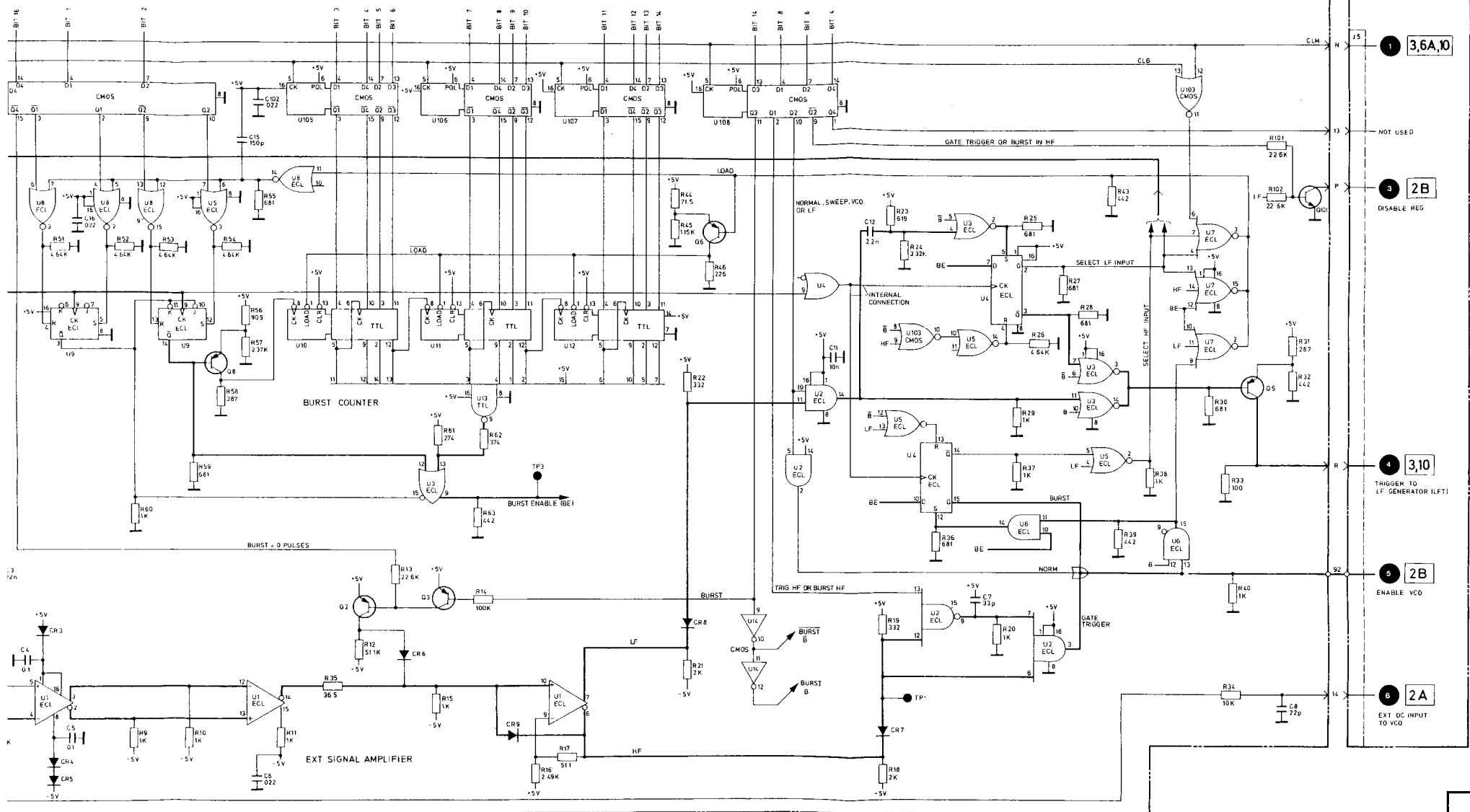

A7 EXT INPUT BURST COUNTER



- 1 3,6A,10
- NOT USED
- 3 2B
DISABLE REG
- 4 3,10
*HIGHER TO LF GENERATOR ILFT1
- 5 2B
ENABLE VCO
- 6 2A
EXT DC INPUT TO VCO

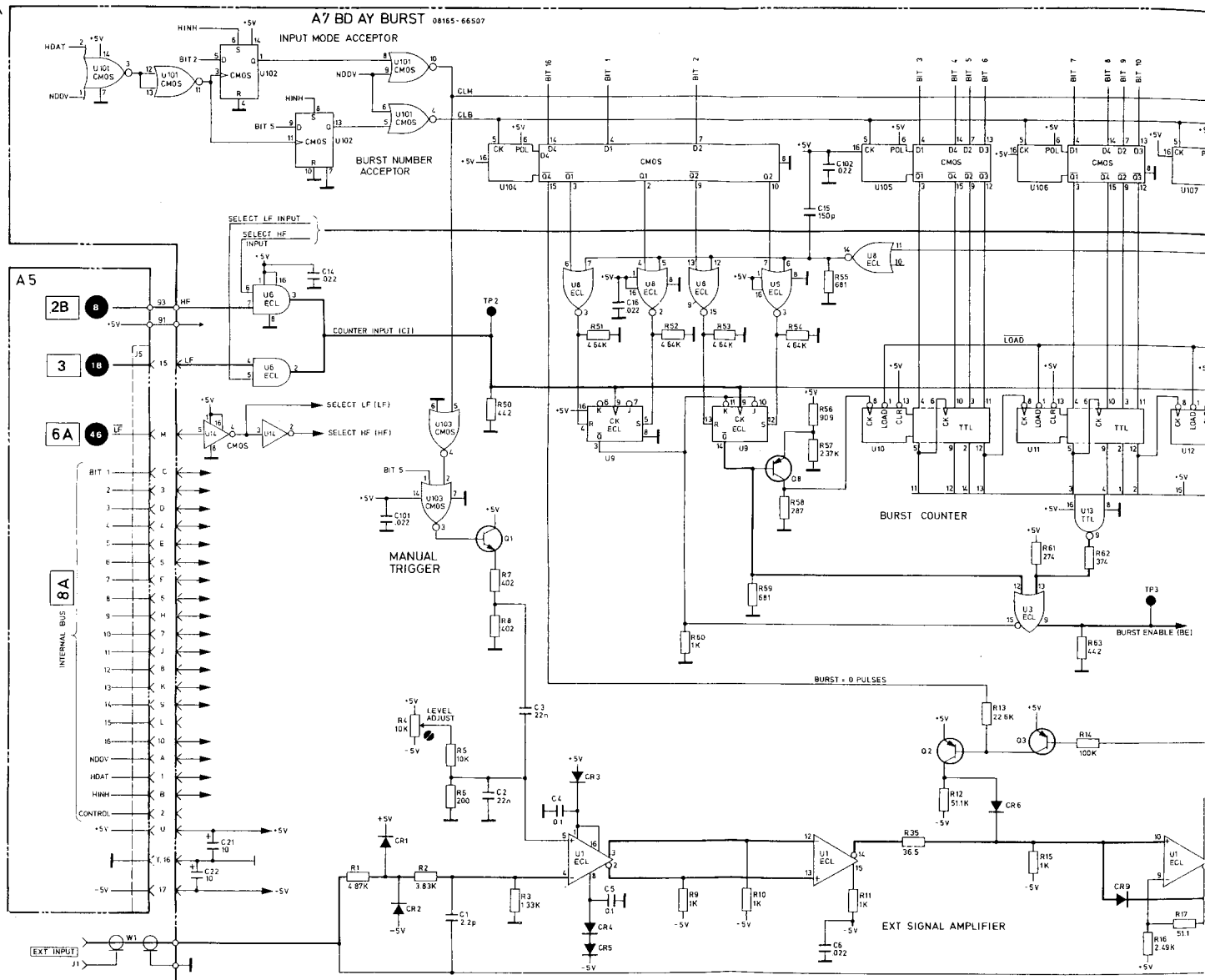

A B C D E F G H I J K L M

A8 BD AY VCO CONTROL 08165-66508 STANDARD (08165-66520 OPT. 002)

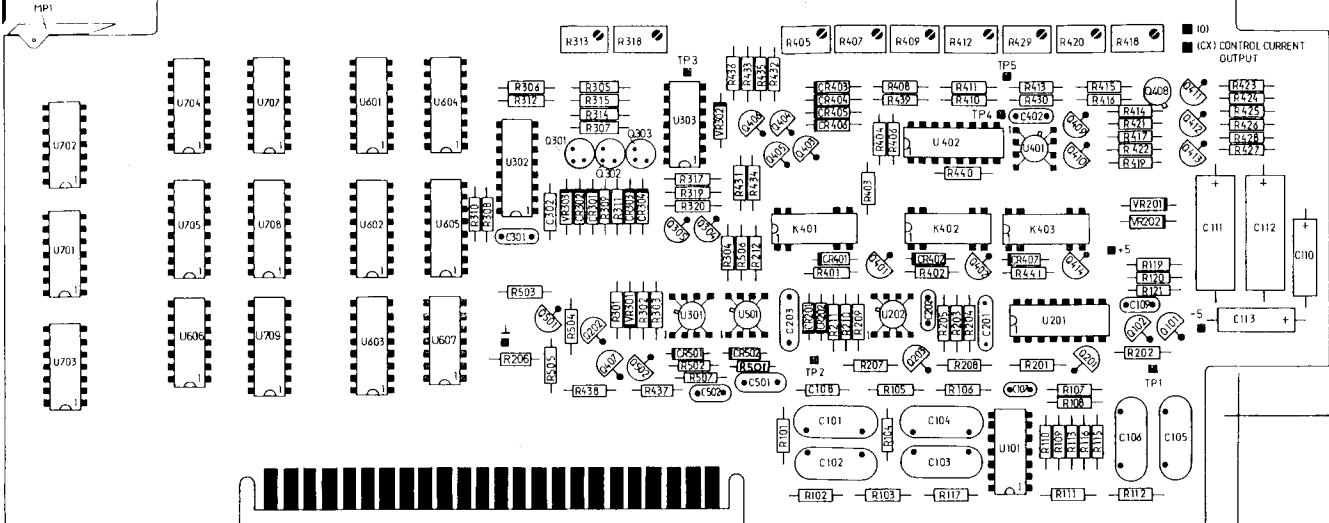

1 2 3 4 5 6 7 8 9 10 11 12 13 14 15 16 17 18 19 20 21 22 23 24 THIS SIDE
A B C D E F H I K L M N P R S T U V W X Y Z AA BB OTHER SIDE

1
2
3
4
5
6

REF DESIG	GRID LOC	REF DESIG	GRID LOC	REF DESIG	GRID LOC	REF DESIG	GRID LOC	REF DESIG	GRID LOC	REF DESIG	GRID LOC	REF DESIG	GRID LOC	REF DESIG	GRID LOC	REF DESIG	GRID LOC	REF DESIG	GRID LOC							
C101	G5	C203	G4	CR404	G2	Q301	E2	R108	I4	R204	H4	R307	E2	R203	H3	R418	J1	R433	G2	R507	F4	U606	B4	TP1	J4	
C102	G5	C301	E3	CR405	G2	Q302	E2	R109	I5	R205	H4	R308	D3	R204	H2	R419	J2	R434	G3	U101	I5	U607	D4	TP2	G4	
C103	H5	C302	E3	CR406	G2	Q303	F2	Q411	J2	R110	I5	R206	E4	R309	E3	R405	G1	R435	G2	U201	I4	U701	A3	TP3	F2	
C104	H5	C402	I2	CR407	I3	Q304	F3	Q412	J2	R111	I5	R207	H4	R310	D3	R406	H2	R421	J2	R436	G2	U202	H4	U702	A2	
C105	J5	C501	G4	CR501	F4	Q305	F3	Q413	J2	R112	J5	R208	H4	R311	F3	R407	G1	R422	J2	R437	F4	U301	F4	U703	A4	
C106	J5	C502	F4	CR502	G4	Q401	H3	Q414	I3	R113	I5	R209	H4	R312	E2	R408	H2	R423	K2	R438	E4	U302	E2	U704	B2	
C107	I4	CR201	G4	K401	G3	Q402	I3	Q501	E4	R115	I5	R210	G4	R313	E1	R409	H1	R424	K2	R439	H2	U303	F2	U705	B3	
C108	G4	CR202	G4	K402	H3	Q403	G2	Q502	F4	R116	I5	R211	G4	R314	E2	R410	H2	R425	K2	R440	H3	U401	I2	U706	B4	
C109	J4	CR301	E3	K403	I3	Q404	G2	R101	G5	R117	H5	R212	G3	R315	E2	R411	H2	R426	K2	R441	I3	U402	H2	U707	C2	
C110	K3	CR302	E3	MP1	A4	Q405	G2	R102	G5	R119	J3	R301	F4	R317	F3	R412	H1	R427	K2	R502	F4	U501	G4	U708	C3	
C111	J3	CR303	F3	Q101	J4	Q406	G2	R103	H5	R120	J3	R302	F4	R318	F1	R413	I2	R428	K2	R503	E4	U601	D2	U709	C4	
C112	K3	CR304	F3	Q102	J4	Q407	E4	R104	H5	R121	J3	R303	F4	R319	F3	R414	J2	R429	I1	R504	E4	U602	D3	VR201	J3	
C113	K4	CR401	G3	Q201	I4	Q408	J2	R105	H4	R201	I4	R304	F3	R320	F3	R415	J2	R430	I2	R505	E4	U603	D4	VR202	J3	
C201	I4	CR402	H3	Q202	E4	Q409	I2	R106	H4	R202	J4	R305	E2	R401	G3	R416	J2	R431	G3	R505	E4	U604	D2	VR301	F4	
C202	H4	CR403	G2	Q203	H4	Q410	I2	R107	I4	R203	H4	R306	E2	R402	H3	R417	J2	R432	G2	R506	G3	U605	D3	VR302	F2	
																							VR303	E3		

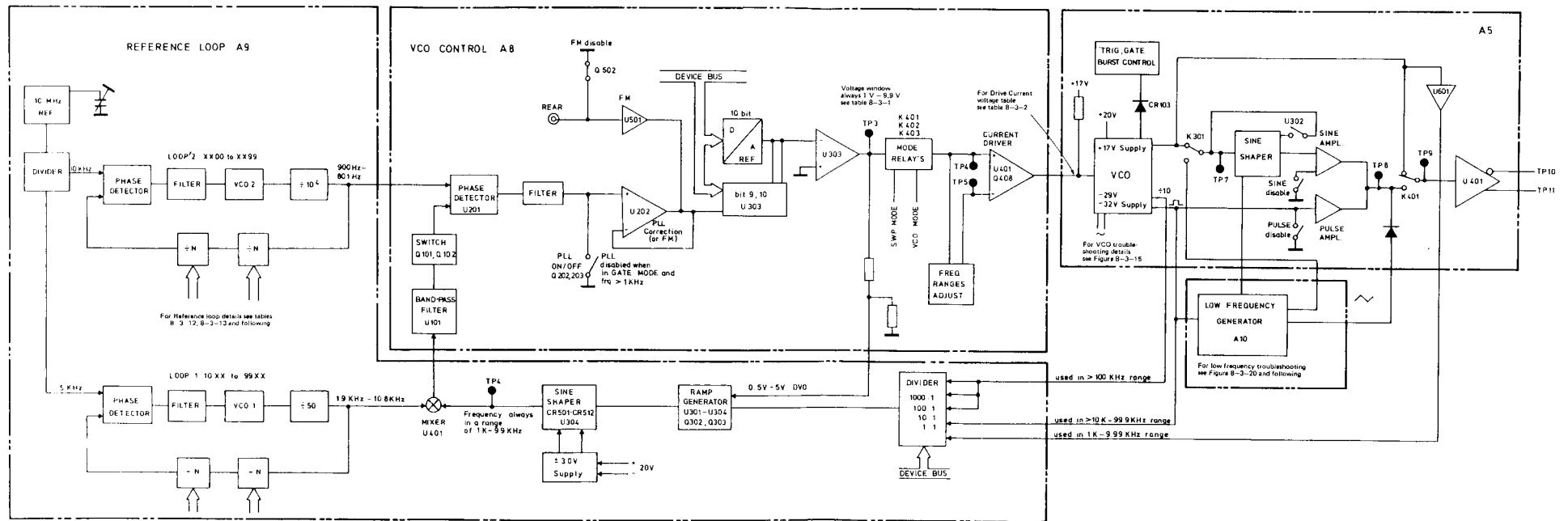
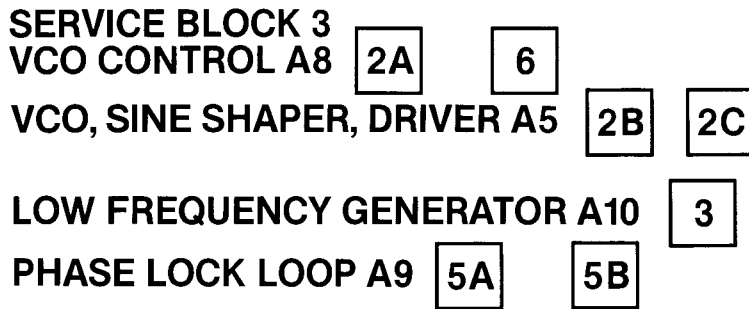

Figure 8-3-1. Frequency generation block diagram



THEORY OF OPERATION

General

As can be seen from the block diagram given in Figure 8–3–1, the circuits associated with frequency generation can be divided into the following functions:

- voltage controlled oscillator (VCO)
- VCO control
- phase-locked loop (PLL)
- low frequency generator (LFG)
- function and pulse generation

The VCO generates a triangular voltage in the range 1 kHz to 50 MHz by charging and discharging a capacitor at a constant rate (further details are given later in this Service Block). Depending on the 8165A output frequency selected, and on the operating mode, the VCO output is frequency synthesized by the PLL. In Normal mode, the PLL is operative at all 8165A output frequencies. In Burst, Gate, and Trigger modes, the PLL is disabled at 8165A output frequencies above 1 kHz. In Sweep and VCO modes, the PLL is disabled at all frequencies.

VCO Control (Service Sheet 2A)

The control current output from the current driver (U401, Q408) to the VCO is determined mainly by the frequency and mode settings of the 8165A. If VCO or Sweep mode is selected, the voltage signal for the current driver is routed from the associated external BNC connectors via relay contacts K403 (Sweep) and K402 (VCO). In all other modes, the voltage signal for the current driver is derived from the 10-bit D/A converter (U302, Q304, Q305). Depending on the 8165A frequency setting, the microprocessor transmits the required digital data, via bits 1–10, to the D/A converter (Table 8–3–1 and 8–3–2 relate frequency settings to the D/A converter inputs). The D/A converter output then provides a coarse tuning signal for the VCO. Should the PLL be switched on, via Q202 and Q203, fine tuning of the D/A converter output is achieved via the action of current sources U303, Q301, Q302 and Q303. (Details of the PLL are given later in this Service Block).

VCO (Service Sheet 2B)

The main VCO generates a ramp in the range 1 kHz to 50 MHz. In the range 1 kHz to 19.99 MHz the range symmetry is selectable (20, 50, 80 %), at 20 MHz and above the symmetry is a fixed 50 %. A pulse waveform, converted from the ramp by a Schmitt trigger is also available. The following circuits make up the main VCO:

I_x and I_y constant current sources and range selector – these are described in the next paragraph.

Pulse selector which selects the input for the next stage (shaper/driver) and SYNC OUT amplifier. For output frequencies of 1 kHz and above, the VCO signal is selected. For frequencies of 999 Hz and below, the LFG's signal is used.

Ramp buffer which inputs to the shaper/driver for sine/ramp/triangle operation.

Buffer (Q202) for input to LFG.

Part (U201) of "÷ R" counter of the main VCO loop.

The VCO's output ramp voltage is generated by charging and discharging a capacitor at a constant rate (see Figure 8-3-2). This is achieved using a switchable positive current source (I_x) and a smaller negative current source (I_y). When the positive current source is on, the capacitor charges at $I_x - I_y$ mA. When the positive current source is off, the capacitor discharges at I_y mA.

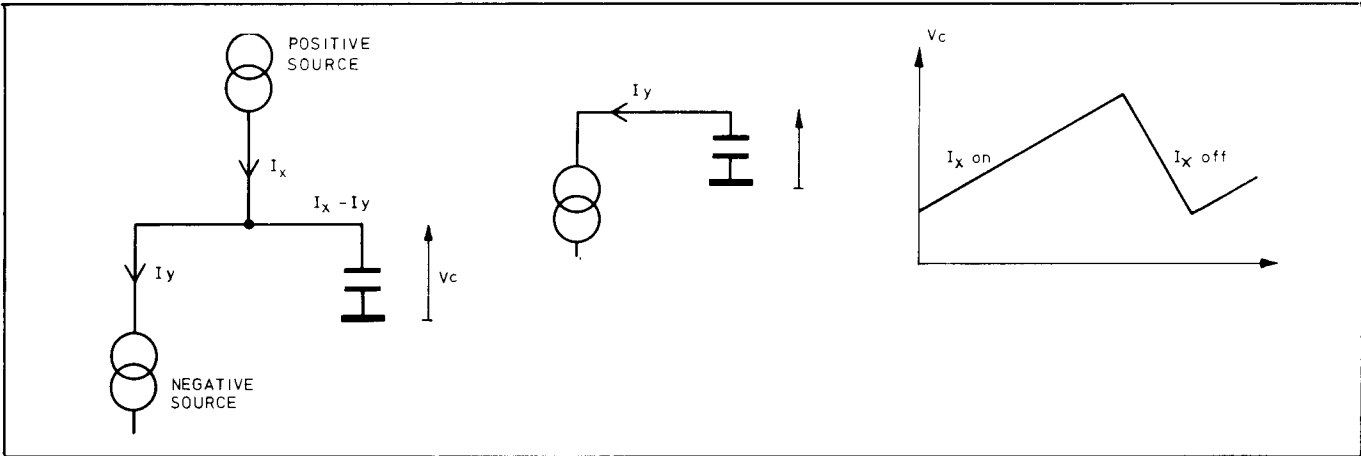

Figure 8-3-2. Ramp Generation

Positive source switching is achieved by a series transistor (long tail pair Q7) controlled by the Schmitt trigger driven from the ramp voltage (see Figure 8-3-3).

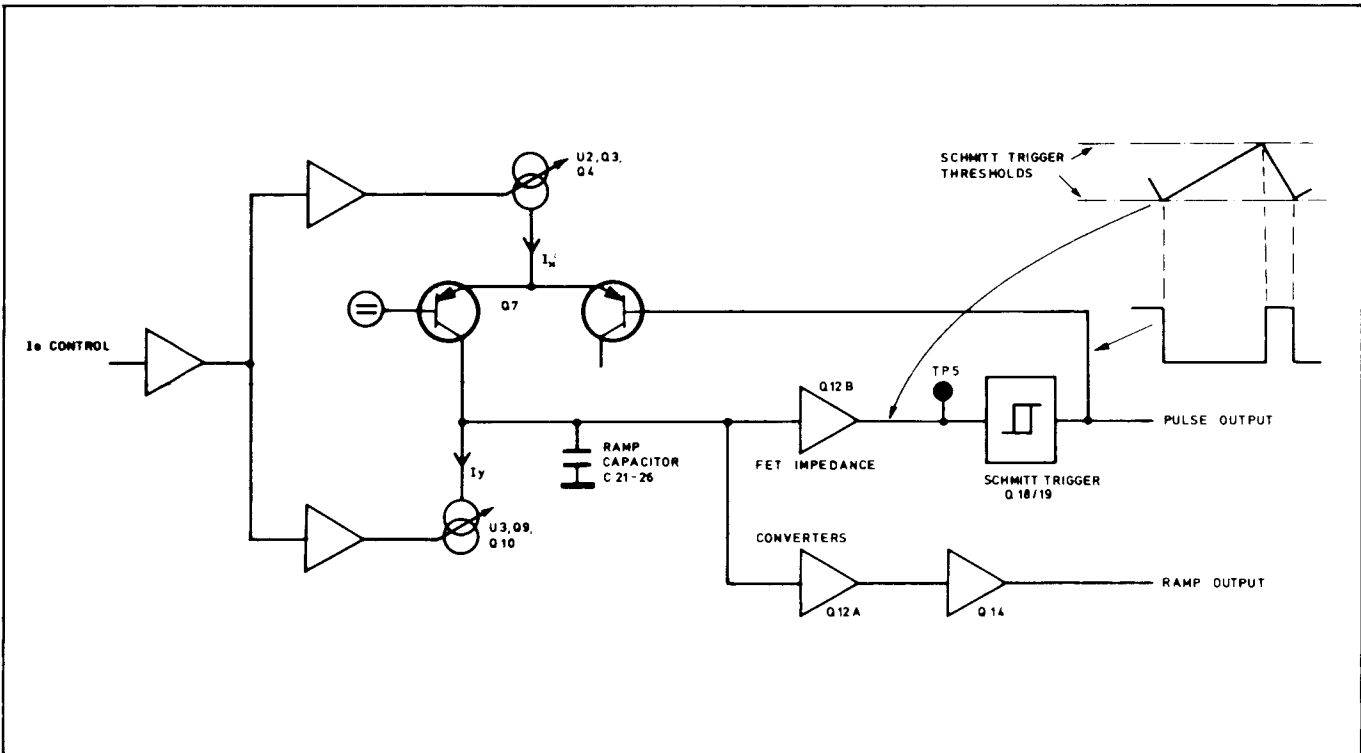

Figure 8-3-3. Positive Source Switching

Trigger, Burst and Gate Operation (Service Sheet 2A)

The rest periods in Trigger, Burst and Gate operation represent disablement of the main VCO (for frequencies of 1 kHz and above). Disablement is achieved by clamping the ramp capacitor via CR103 to a level representing the baseline. To trigger or re-enable the main VCO, signal 5 at the input to the Trigger, Gate, Burst Control circuit goes high. As shown in the following diagram, Figure 8-3-4, Q103 then opens, CR103 is reverse-biased and the ramp capacitor is de-clamped.

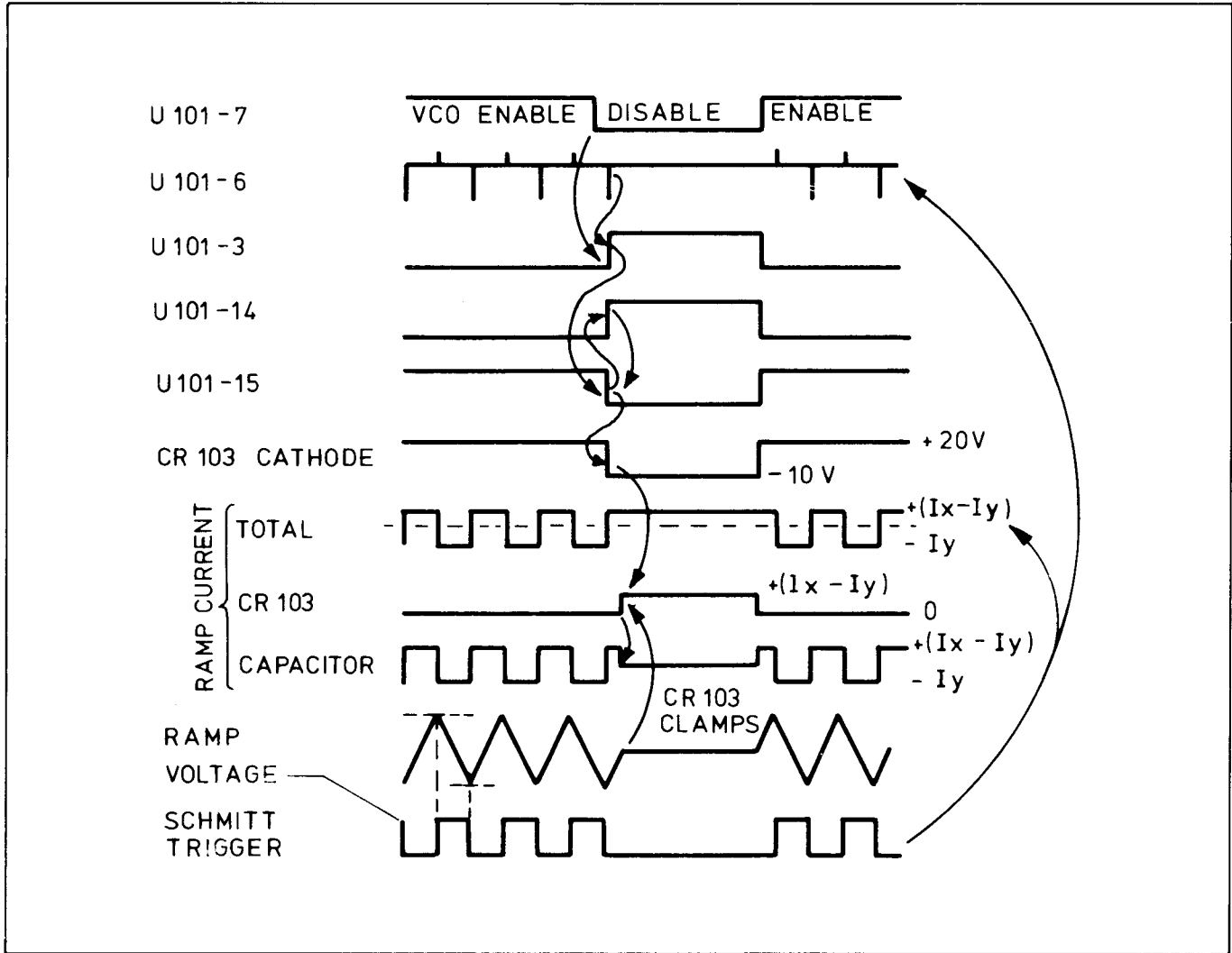

Figure 8-3-4. Main VCO Timing and Enablement

To define the baseline, the clamp diode is fed with a current which reflects the ramp capacitor's discharge current. This is achieved by feeding an I_y factor to the clamp diode's current source (Q107, U5, Q104, Q103).

Frequency and Symmetry (Service Sheet 2A)

Frequency is determined by the time taken for the ramp voltage to reach the Schmitt trigger thresholds. Consequently, it is dependent on ramp capacitor value and charge and discharge currents. Symmetry depends on the ratio of charging current ($I_x - I_y$) and discharging current (I_y). As shown in the following troubleshooting tables, capacitor value is switched by the Range Selector circuit, and current ratio is controlled by the relays K1, K2, K3. Absolute current values are dependent on the control signal 47. This is derived in board A8 (Service Sheet 2A) from a D/A converter to which digitally-coded frequency information from the microprocessor is applied.

Correction for Propagation Delay (Service Sheet 2A)

At high frequencies, the propagation delay of the Schmitt trigger and current source switch are significant. The resistive network R50, R51, RT1 compensates for this by causing the Schmitt trigger to switch before the ramp voltage at the take-off point across C26 reaches its peaks.

Compensation for Range Selector Impedance (Service Sheet 2A)

In the frequency range 1–999 kHz, C23, C24 and C25 are switched into operation by Q513. The transistor impedance (characterized by a step at the ramp peaks) is offset by applying the I_x current via Q512 to the capacitors during discharge. At frequencies of 1 MHz and above, when C23, C24 and C25 are not used, the I_x current flows via Q511 to the -5 V supply.

PLL (Service Sheets 2A, 2B, 5A, 5B and 6)

The 8165A uses a phase-lock loop (PLL) method of indirect frequency synthesis which gives the advantage of transferring the accuracy and stability of a crystal source to the variable-frequency output. The following paragraphs contain some PLL generalities before proceeding with the configuration used in the 8165A.

Figure 8–3–5 illustrates a basic PLL frequency synthesizer in which a voltage-controlled oscillator (VCO) is roughly tuned to the required frequency by a tuning voltage. A portion of the output signal is compared with a stable reference frequency, and any phase difference appears as a voltage at the output of the phase detector. This signal is smoothed and applied to the VCO where it corrects the output frequency.

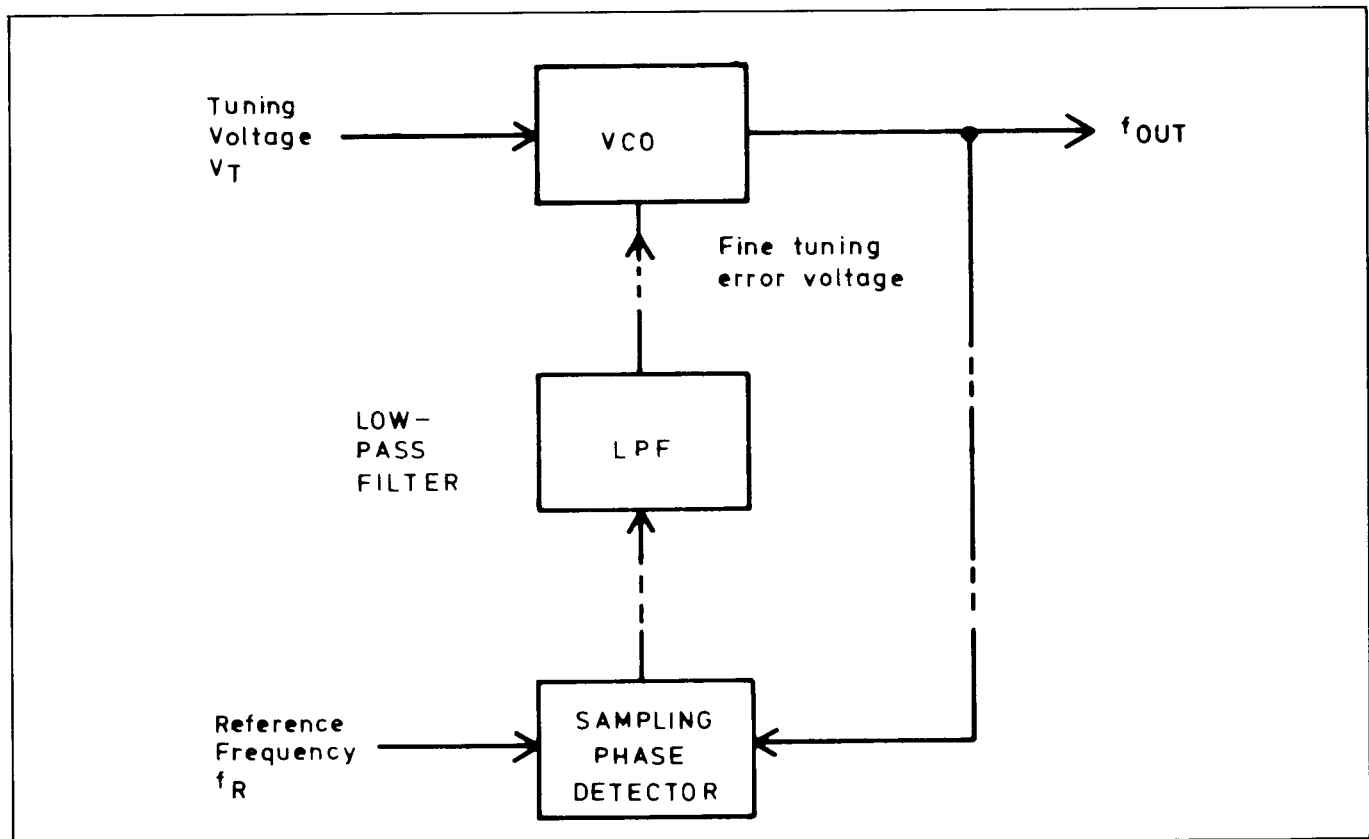

Figure 8–3–5. Basic PLL Frequency Synthesizer

Variable frequencies may be generated by inserting a programmable divider in the f_{OUT} feed to the phase detector (Figure 8-3-6). Then, for zero phase detector output, $f_{OUT}/N = f_R$.

Hence $f_{OUT} = Nf_R$ and, by changing the value of N , f_{OUT} can be changed.

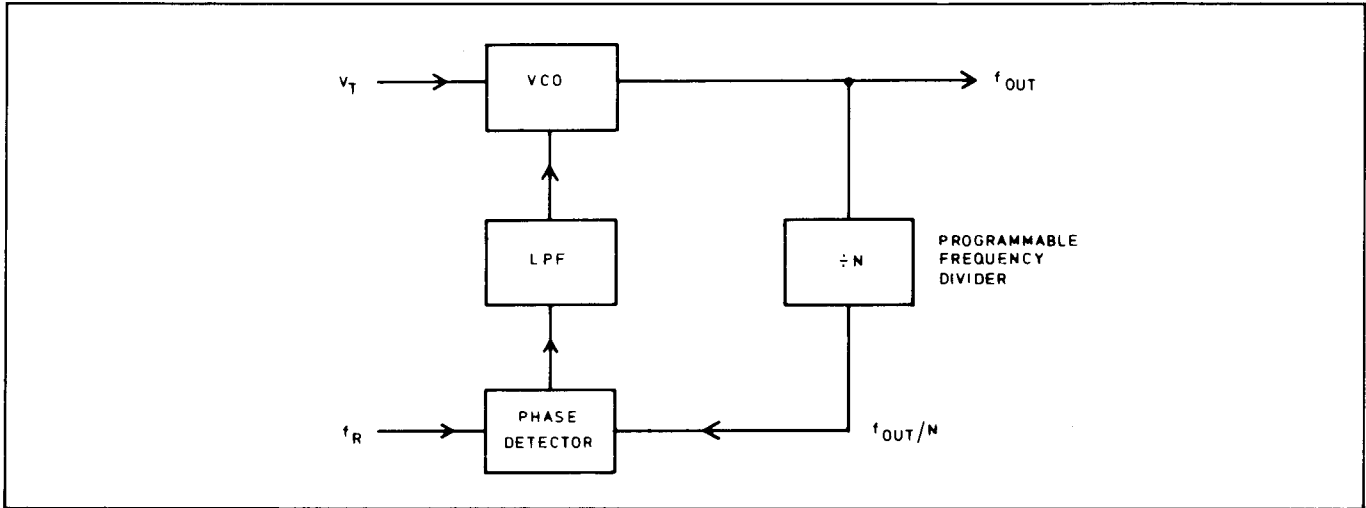

Figure 8-3-6. Typical Variable – frequency Synthesizers

In practical circuits, several loops are used so that, by keeping N small, the settling time is reduced. As shown in Figure 8-3-7, two variable-frequency synthesizers (loop 1 and loop 2, each identical to Figure 8-3-6) are used in the 8165A in addition to the main reference loop. These effectively provide the $\div N$ function. VCO tuning is accomplished via the internal bus and the VCO control. The output frequency, f_{OUT} , is divided by a factor R so that the main reference loop operates only in the frequency range 1–10 kHz. Thus, for output frequencies up to 50 MHz, R takes the following values:

f_{OUT}	R	f_T
1 kHz – 9.999 kHz	1	1 kHz – 10 kHz
10 kHz – 99.99 kHz	10	
100 kHz – 999.9 kHz	100	
1 MHz – 9.999 MHz	1000	
10 MHz – 50 MHz	10000	

The divide-by- R counter output (f_T) is applied to a ramp generator (Service Sheet 5B) and sine shaper (Service Sheet 5B) to provide a sine wave which is then mixed with the f_1 output (signal 28 on Service Sheet 5B) of loop 1. The difference frequency $f_T - f_1$ is filtered from the mixer output and compared with loop 2's frequency f_2 . To understand the action, suppose f_{OUT} is accurate and that the phase detector output is zero, then $f_1 - f_T = f_2$ and hence:

$$f_{OUT} = Rf_T = R(f_1 - f_2). \text{----- (1).}$$

Values are assigned to f_1 and f_2 as follows:

$$f_1 = \text{first two frequency digits} + 0.9 \text{ kHz}$$

$$f_2 = 900 \text{ Hz} - \text{last two frequency digits}$$

As an example, suppose an output frequency of 1.234 kHz is required, then:

$$f_1 = 1.2 + 0.9 = 2.1 \text{ kHz}$$

$$f_2 = 900 - 34 = 866 \text{ Hz}$$

Hence, $f_1 - f_2 = 2.1 \text{ kHz} - 866 \text{ Hz} = 1.234 \text{ kHz}$. Substituting for $(f_1 - f_2)$ in (1):

$$f_{OUT} = 1.234 \text{ kHz} \text{ (R = 1 in this range).}$$

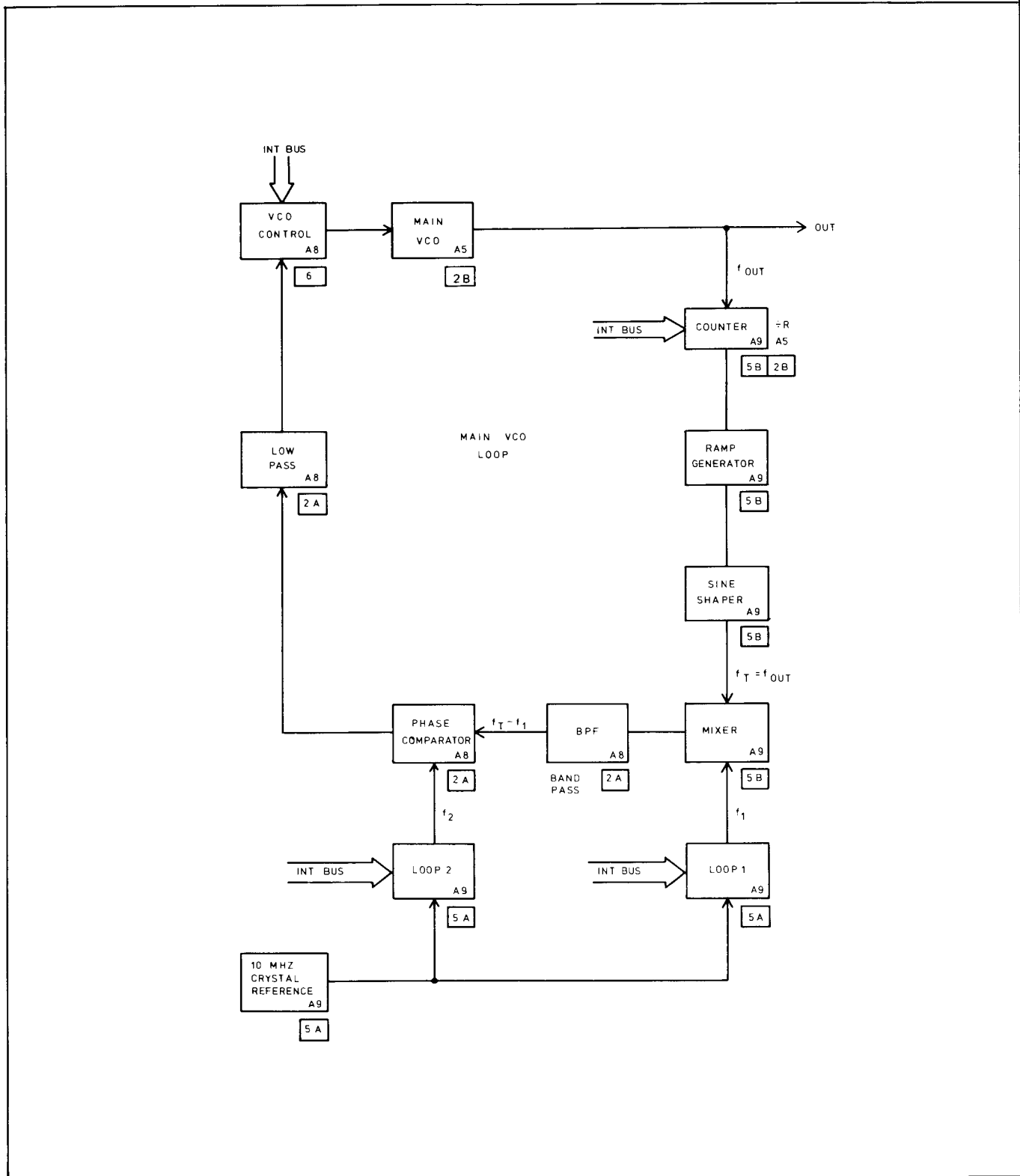

Figure 8-3-7. Frequency Synthesis in the 8165A

Low Frequency Generator (Service Sheet 3)

Main functions of the LF Generator are:

- divide the output of the main VCO by an exact multiple of 10,
- define duty cycle/symmetry,
- generate square and triangular waveforms accordingly.

Division of the VCO frequency is accomplished by the fixed intrinsic divisions of the step generator ($\div 10$) and triangle generator ($\div 10^3$) and the selectable factors of 1, 10 or 100 of the frequency divider.

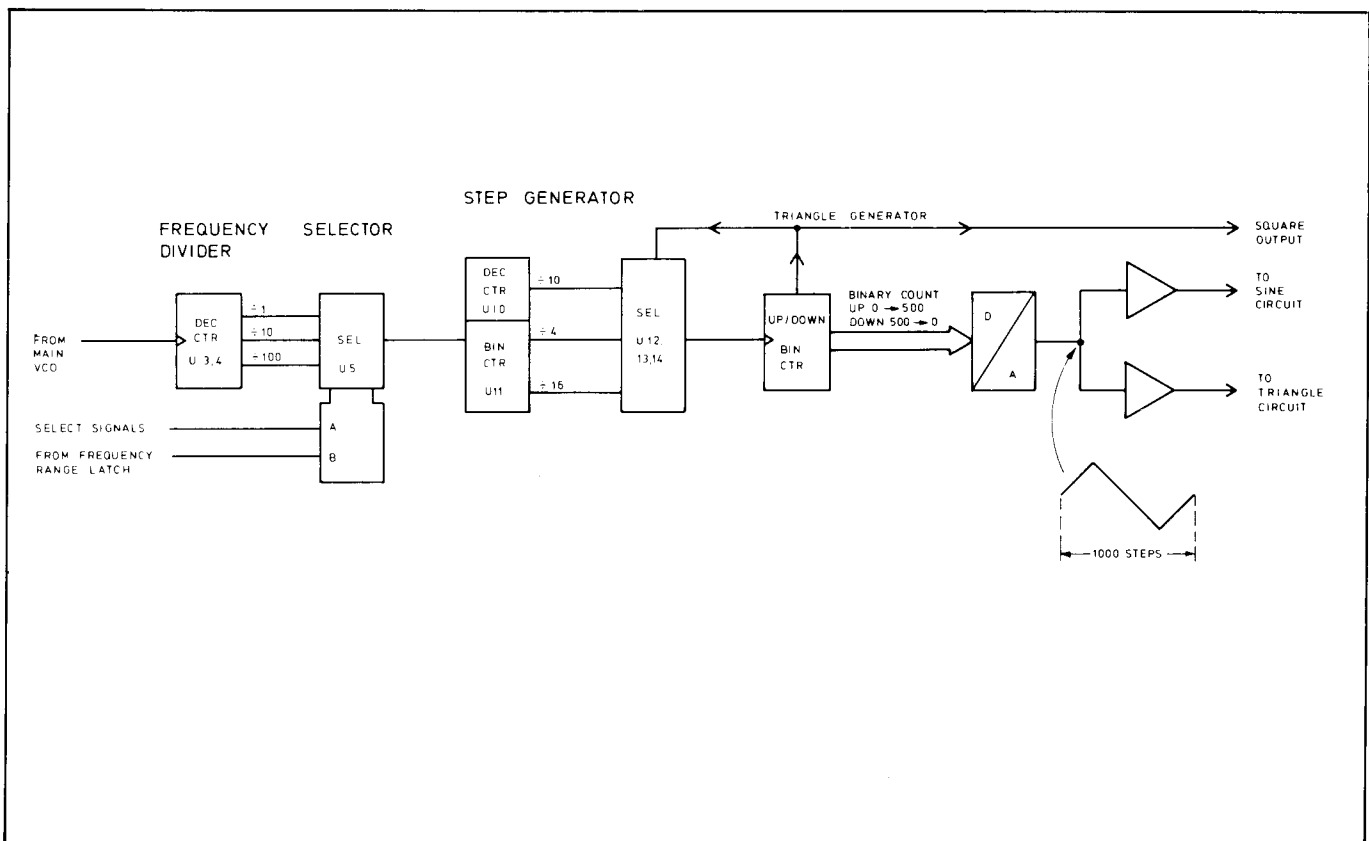

Figure 8-3-8. LF Generator: Block Diagram

Duty cycle or symmetry of the output waveform is determined by the step generator. This provides a clock signal at one-tenth of the divider's output frequency when an output waveform of 50 % duty cycle or symmetry is required. For values of 20 or 80 %, the step generator provides one-quarter and one-sixteenth frequencies for the appropriate rising or falling parts of the waveform.

The step generator's output increments a 9-bit binary counter which automatically reverses its direction at counts of zero and 500. D/A conversion then produces a stepped approximation to a triangle or ramp waveform. With maxima and minima occurring at the counter's zero- and 500-states, each output cycle consists of 1000 steps. As Figure 8-3-9 indicates, U20 triggers the toggle U9 when the counter reaches 500. Consequently, signal NUP goes high, and the counter counts down. On reaching a count of zero, the max/min signals from each counter element (U16, 17, 18) go high and, via U19, reverse the U9 toggle and hence the count direction. At the same time, the YHP signal selects the appropriate step rate.

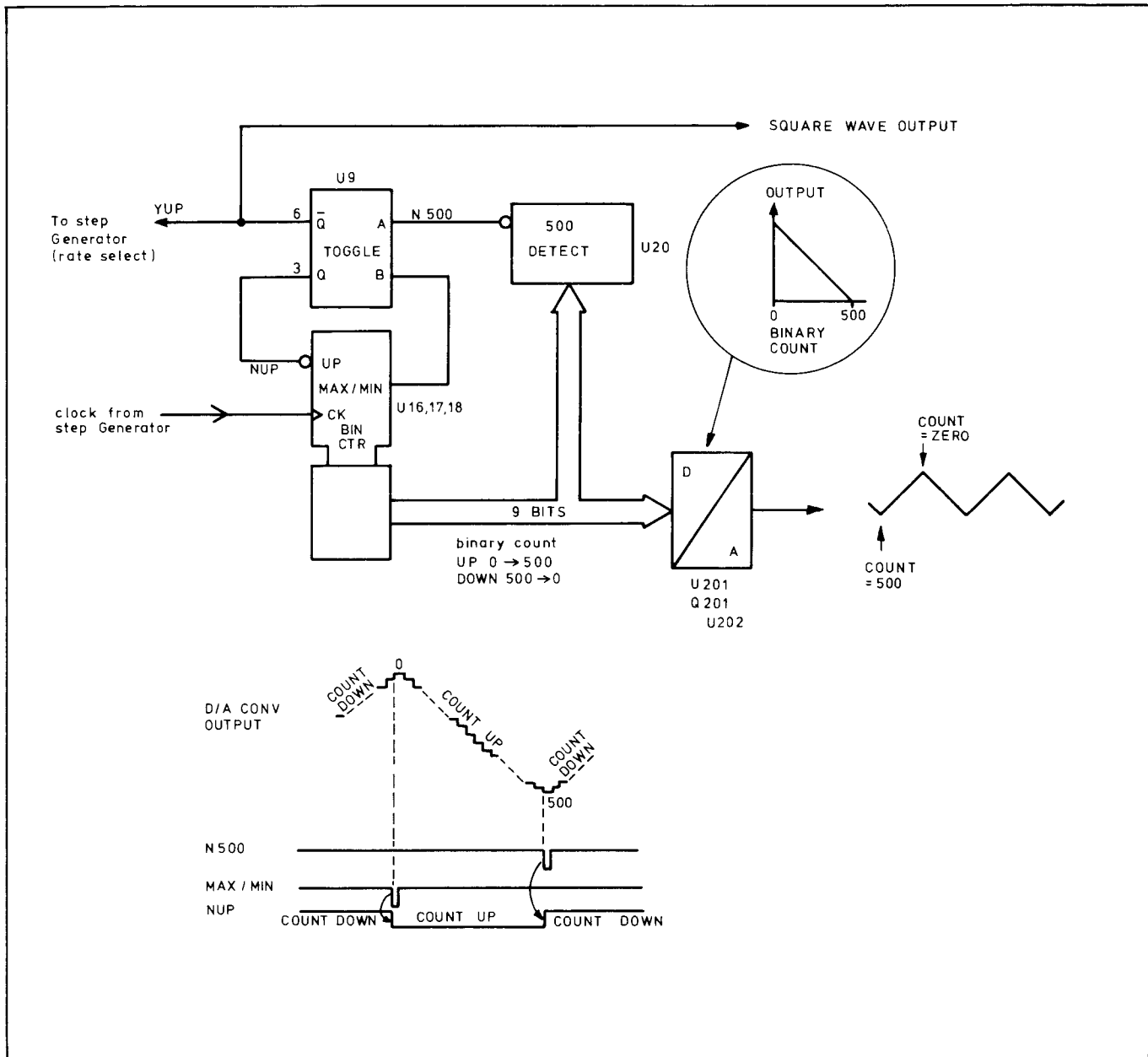

Figure 8-3-9. Triangle Generator, Up/Down Logic

The D/A converter's output is fed via separate buffers to a sine shaper (for sine wave operation) and the output amplifier driver (for triangle/ramp operation), see Service Sheet 2C. For square wave operation, signal YUP is applied via U15 as signal 18 to the pulse selector on Service Sheet 2B. From here, signal 11 carries the YUP information to the output amplifier driver via the pulse amplifier on Service Sheet 2C.

When trigger, burst or gate modes are selected, the number 249 is loaded into the counter and the frequency divider is disabled (U2 puts a positive pulse on the COUNT line, and a negative pulse on the LOAD line. The input mode acceptor's Gate/Trigger/Burst signal also resets U8 (pin 14) so that the selector is disabled). Hence, the D/A converter input assumes a fixed value of 249, and its output consequently remains static at a middle value.

In trigger mode, the trailing (negative going) edge of the LFT pulse (Signal 4 from Service Sheet 1) clocks U6 which, through the agency of U7/8/9, enables the frequency divider's selector. After one complete output cycle, when the counter assumes a value of 249 for the second time, the selector is once again disabled. This activity is shown in

Figure 8-3-10. Note that, as the triangle generator must have an intrinsic division of exactly 1000, the true midpoint of the waveform lies between steps 249 and 250; consequently, the baseline defined by step 249 has a slight asymmetry (1 part in 1000).

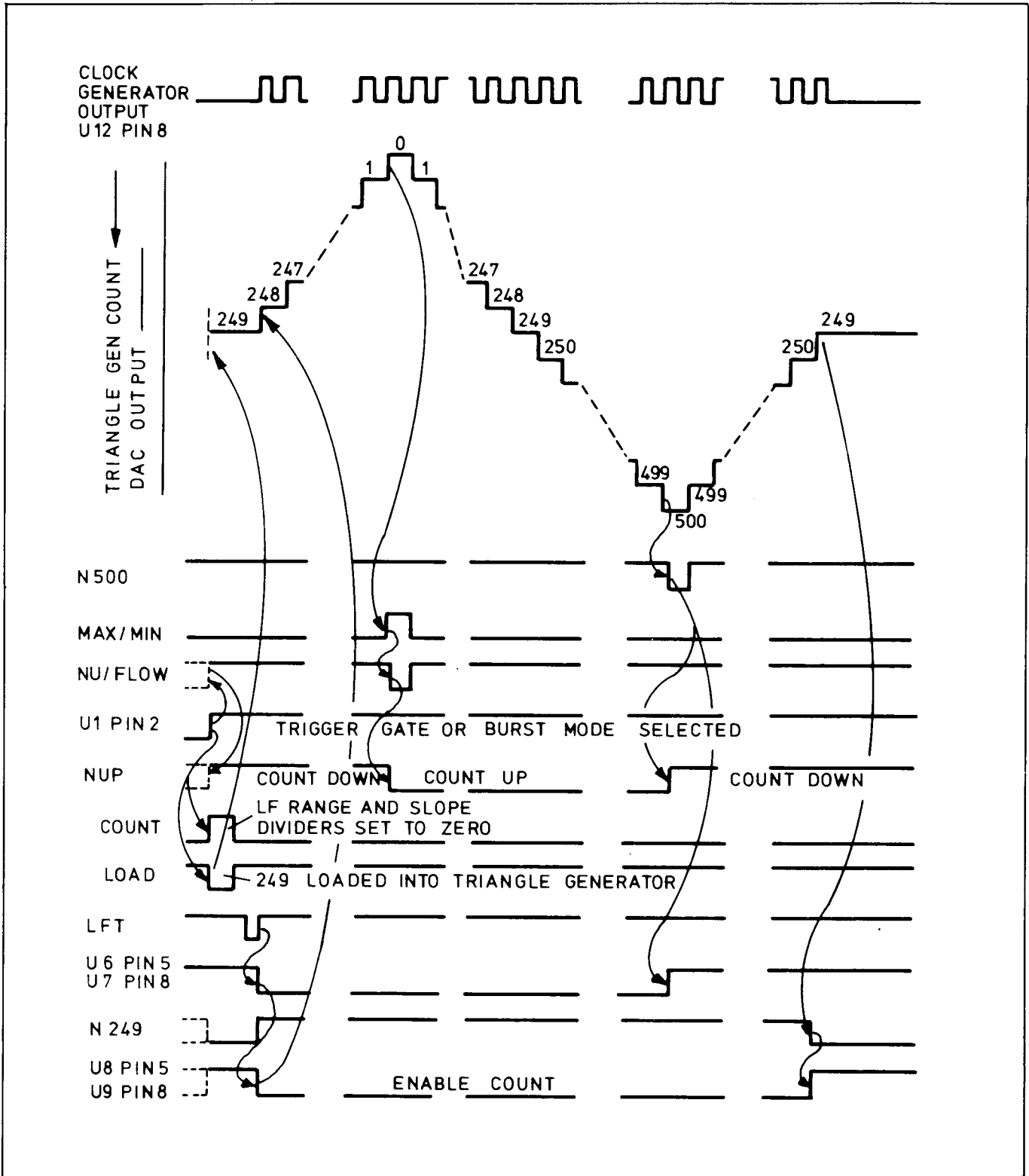

Figure 8-3-10. Operation in Trigger Mode

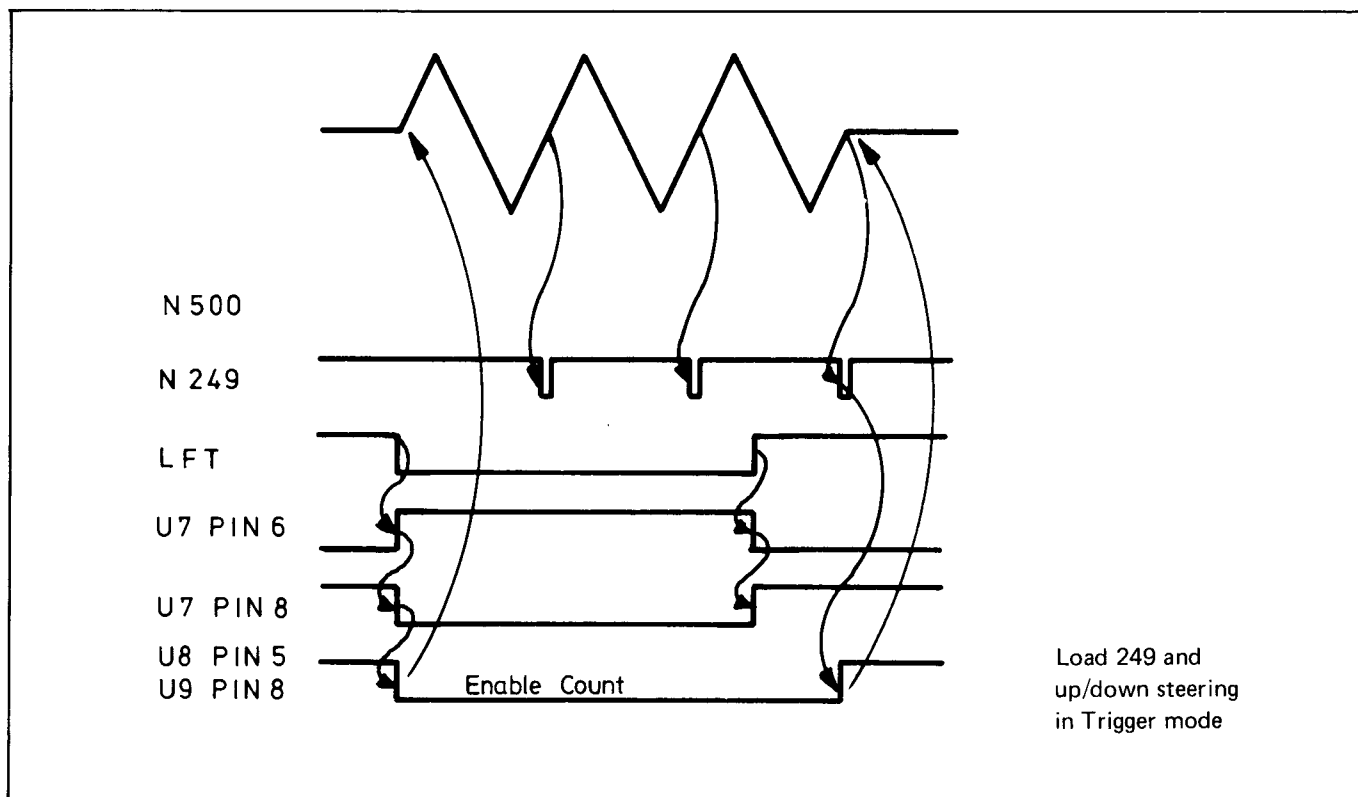

Figure 8-3-11. Count enable in Gate and Burst Modes

In burst and gate modes, the LFT signal remains low for the duration of the counted or gated stream. This means that U7 pin 6 is high. As U7 pin 11 is also high (U7 pin 13 is low), U7 pin 8 is low, the U8 is reset (pin 15) and the frequency divider selector is consequently enabled. When LFT goes high, the counter stops when it next descends to the count 249 (Signal N249 goes low, this clocks the 'upper' U8 which toggles and disables the frequency divider selector).

Sine Generation (Service Sheet 2C)

In sine operation, a triangle is fed via K301 from the VCO (signal 7) or LFG (signal 16) to the sine shaper (U301, U302, U303). This feeds the sine amplifier (Q303), thence to the buffer (Q401) and to the output driver (U401) via K401. The sine shaper consists of five differential amplifiers in parallel, each of different gain and threshold. Net gain is input-amplitude dependent such that a sine wave is produced from the applied triangle.

Sine wave baseline (dc level) is zeroed by the preset baseline adjustment (U401a, Q403, Q301, R350) which applies a dc to each amplifier of the sine shaper. Additionally, automatic level correction is applied via U304 (enabled at frequencies above 1 MHz in NORM, VCO and SWEEP modes) and, for frequencies below 1 kHz, via A10U203a on Service Sheet 3 (see signal 12).

For optimizing distortion, the gain of the sine shaper can be regulated by the preset adjustment (R340, U305).

Sine wave amplitude is controlled by the preset adjustment (R360) of the sine amplifier (Q303). Symmetry is adjusted by the sine offset (R243, U402b, Q212). The sine amplifier is enabled when signal 30 is high.

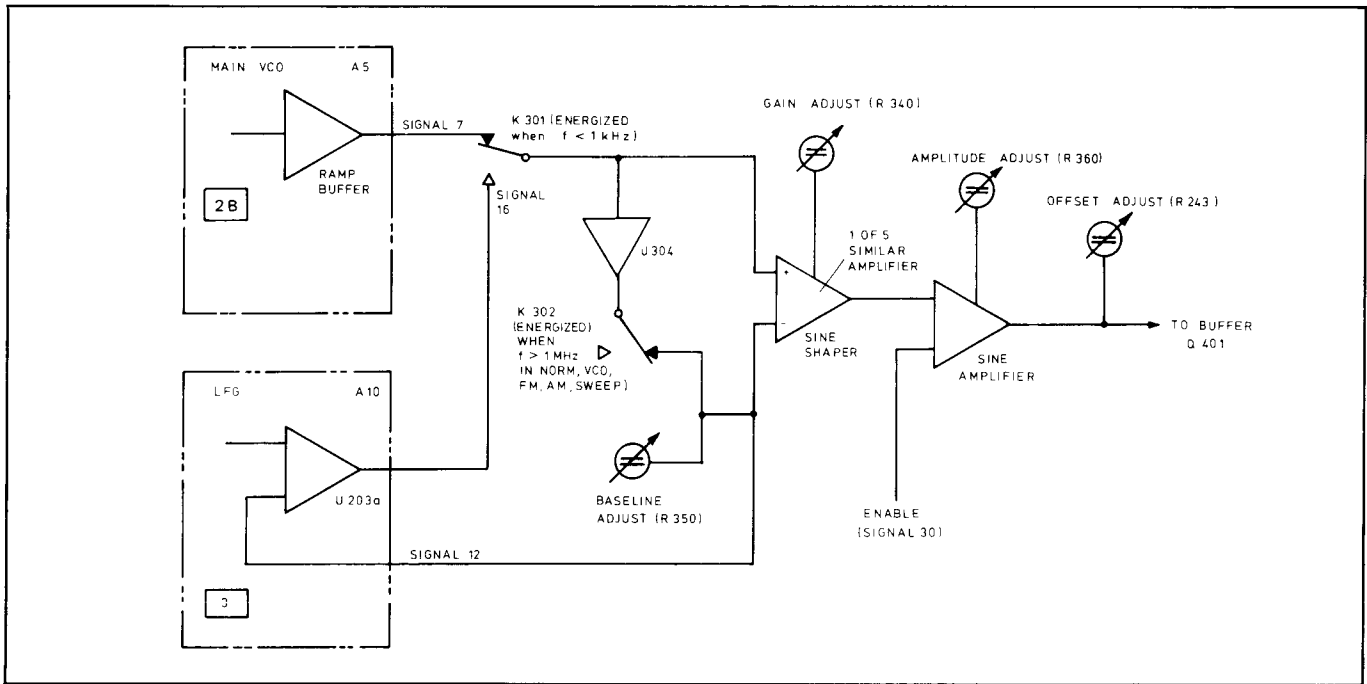

Figure 8-3-12. Sine Operation

Square Wave/Pulse Operation (Service Sheet 2C)

Signal 11 (Service Sheet 2B's pulse selector output) and the pulse amplifier (Q206, Q207, Q208) are enabled by Q205 when signal 42 is low. To obtain a pulse with a zero-volt baseline, an offset (enabled by signal 38 high) is added to the pulse amplifier output. See Q209 to Q212 and U402b.

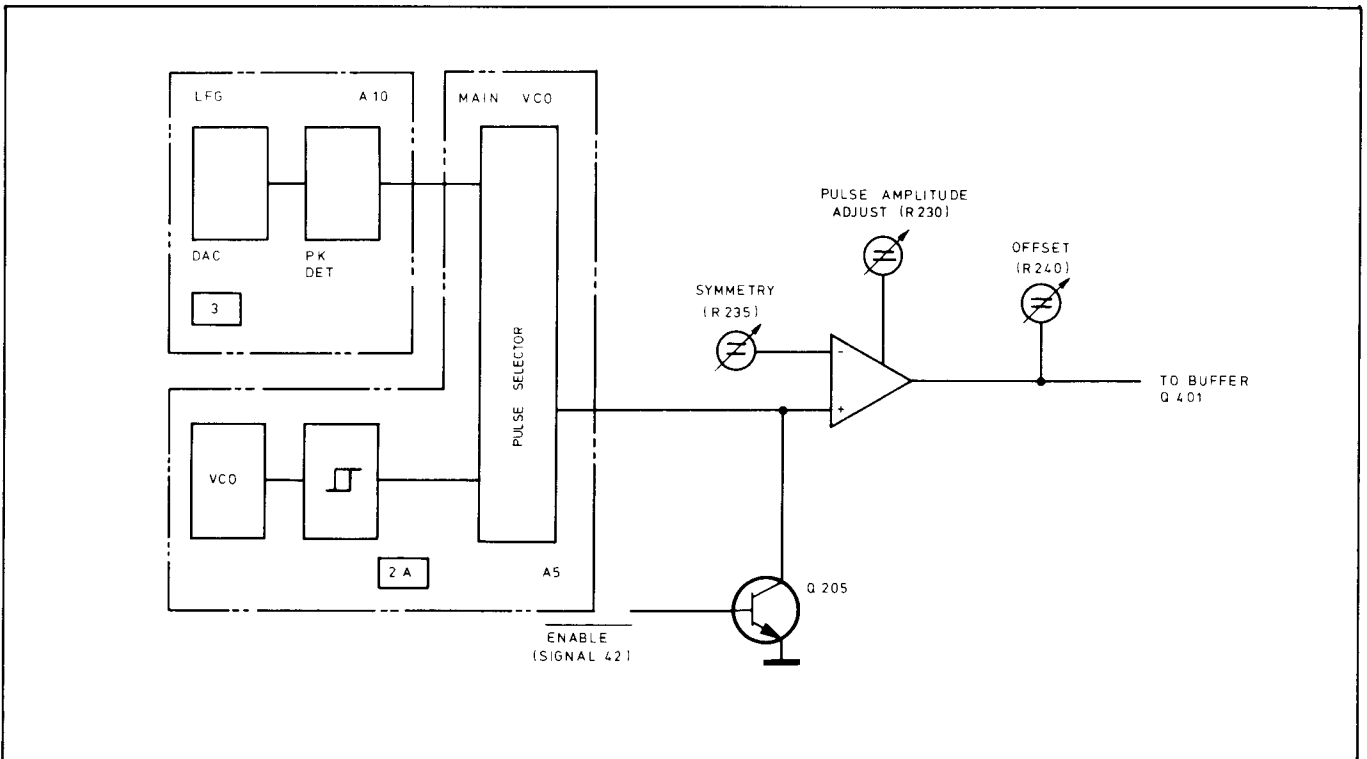

Figure 8-3-13. Square/Pulse Operation

Triangle/Ramp Operation (Service Sheet 2C)

For frequencies above 1 kHz, the VCO ramp (Signal 7) is switched direct to the output driver by K401. For lower frequencies, the LF ramp (signal 17) is applied to K401, via clamp diode CR401 and buffer Q401. The clamp diode is reverse-biased in sine and pulse operation.

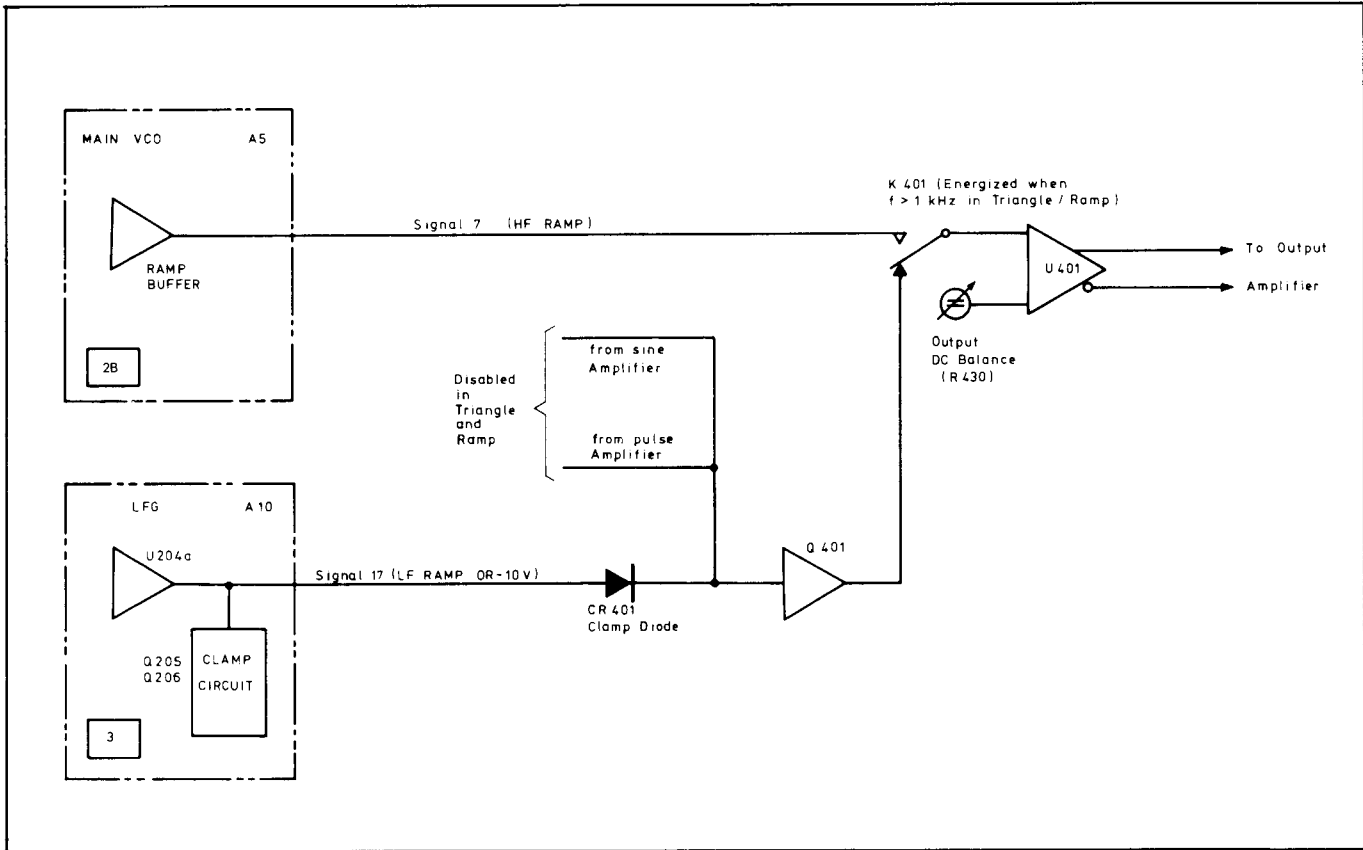

Figure 8-3-14. Triangle/Ramp Operation and Output Driver

Output Driver

The output driver, fed via K401, provides a balanced input to the amplifier board A4. DC level is zeroed by the preset output balance adjustment (R430, U402a, Q403, Q404).

General Frequency Troubleshooting

The 8165A frequency troubleshooting can be split into following sections:

- HF Frequency range 1 kHz to 50 MHz supplied by VCO
- LF Frequency range 1 mHz to 999 Hz supplied by the low frequency generator which divides the VCO frequency.

If no frequency at all or frequency is out of spec perform following test:

Set INPUT MODE to GATE, FRQ > 1 kHz, and apply a positive voltage of ≈ 2.5 V to EXT INPUT. This enables the VCO and disables the PLL. Frequency should now be ≤ ± 5 % at the output.

Check the voltages and information given in the following tables.

Table 8-3-1. FRQ Display to Voltage

Display (3 digit)	D/A Conv. U302							A8 TP3			
	10	9	8	7	6	5	4		3	2	1
1.00	0	0	0	1	1	0	0	1	0	0	1.00 V
1.50	0	0	1	0	0	1	0	1	1	0	1.50 V
3.00	0	1	0	0	1	0	1	1	0	0	3.00 V
5.00	1	0	0	0	0	0	1	1	0	0	5.00 V
7.50	1	0	1	1	1	0	1	1	1	0	7.50 V
9.00	1	1	1	0	0	0	0	1	0	0	9.00 V
9.99	1	1	1	1	1	0	0	1	1	1	9.99 V

Table 8-3-2. FRQ Range to VCO Input (W5)

FRQ ranges	Voltage at VCO input
1 K – 9.99 K	16 V – 7.5 V
10 K – 99.9 K	16 V – 7.5 V
100 K – 999 K	16 V – 7.5 V
1 M – 9.99 M	17.2 V – 14.1 V
10 M – 19.9 M	14.1 V – 11.4 V
20 M – 50 M	13.2 V – 7 V

VCO TROUBLESHOOTING A5

2B

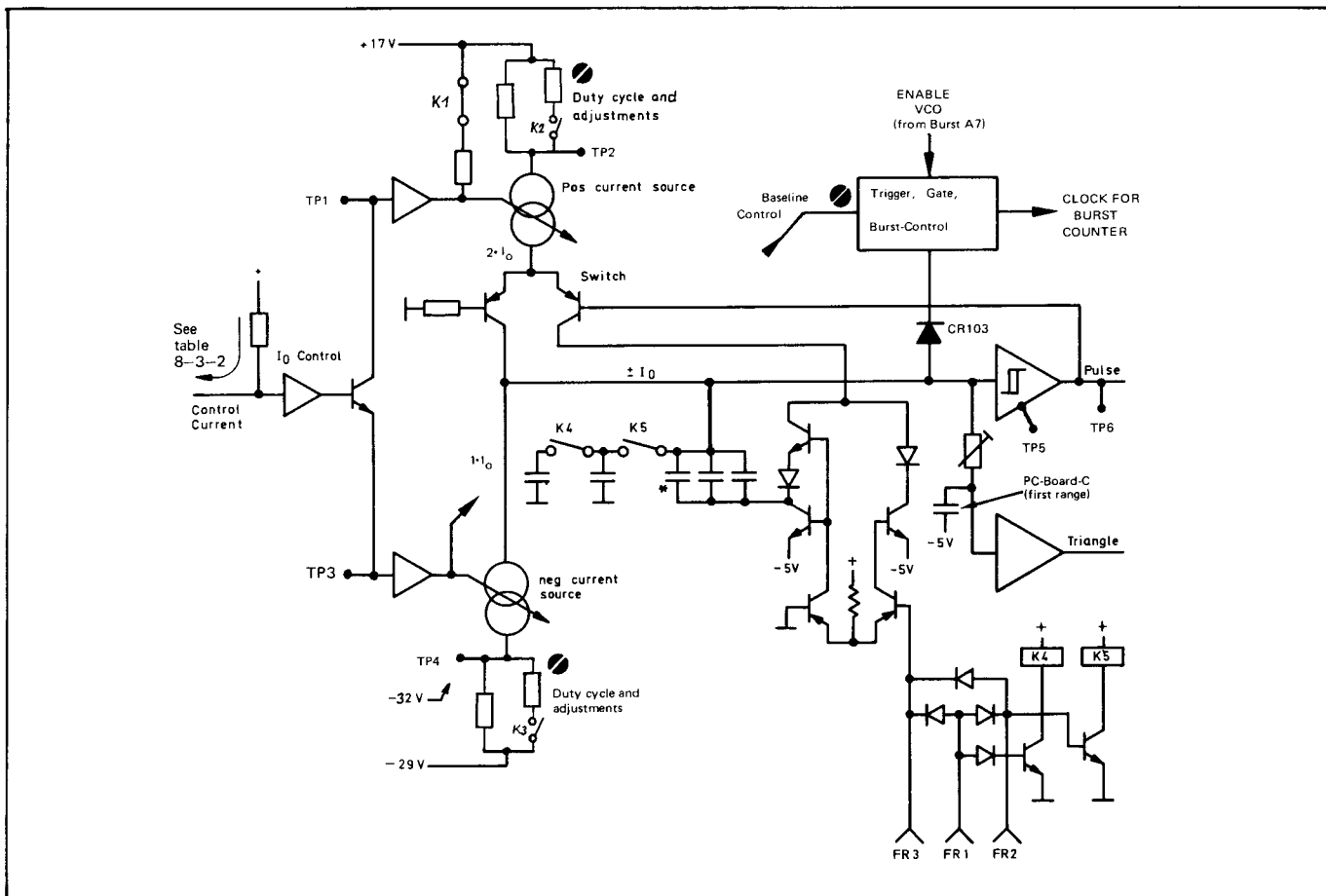

Figure 8-3-15. VCO functional diagram

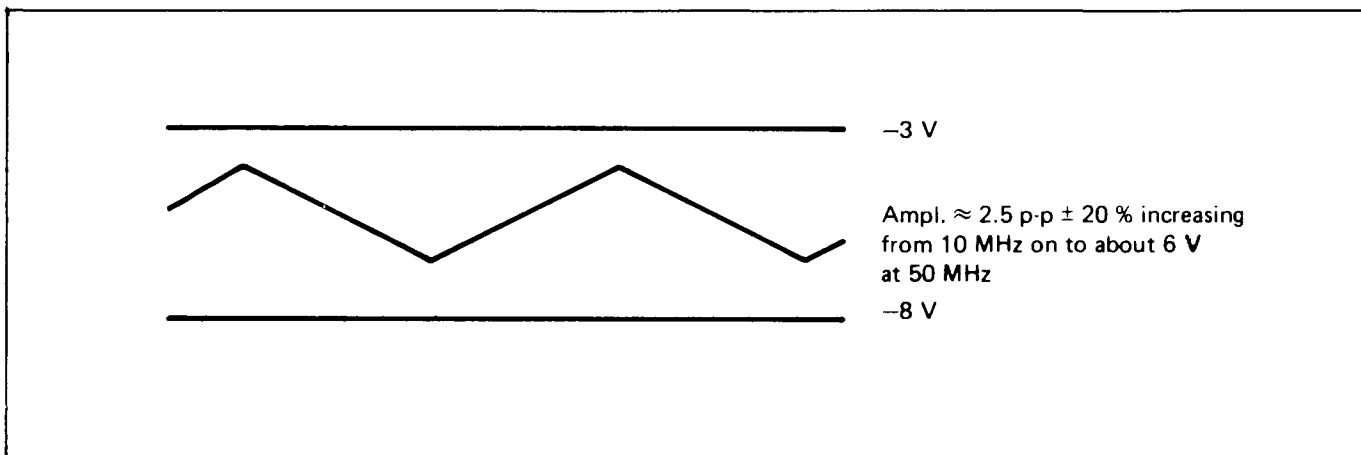

Figure 8-3-16. Triangle voltage window at TP5 (typical)

If triangle window is wrong assume FET Q12 to be defective. An excessively positive window results in an decreasing frequency stability. An excessively negative window may cause malfunction with the TRIG, GATE BURST – Control circuit. For high frequency measurement use sampling scope.

If VCO doesn't oscillate at all:

1. Check the $17\text{ V} \pm 0.4\text{ V}$ and $-29\text{ V} \pm 0.5\text{ V}$ supply voltages.
2. Be sure voltage control table 8-4-2 is true (transferred to TP1 as well).
3. Check that the voltage between TP1/TP2 as well as between TP3/TP4 is zero (adjustable).
4. Check that CR103 has no influence on the VCO by lifting one lead.
5. Measure current sources $2 \cdot I_O$ and $1 \cdot I_O$ as follows:
 Open one lead of L2 and measure current against ground.
 Open one lead of L3 and measure current against ground.
 Compare following current tables in the different duty cycle modes.

Table 8-3-3. Current source linearity

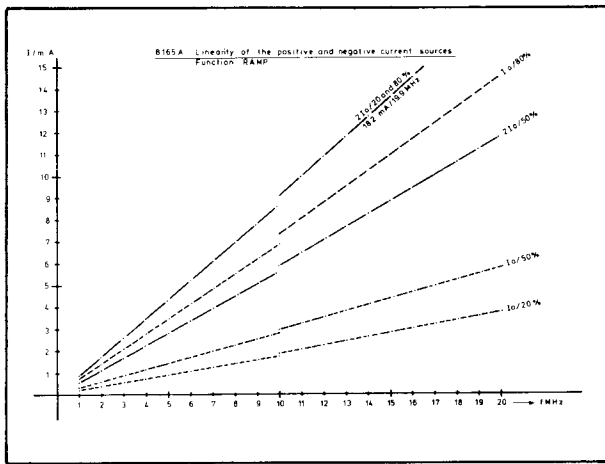

Table 8-3-4. VCO Ranges

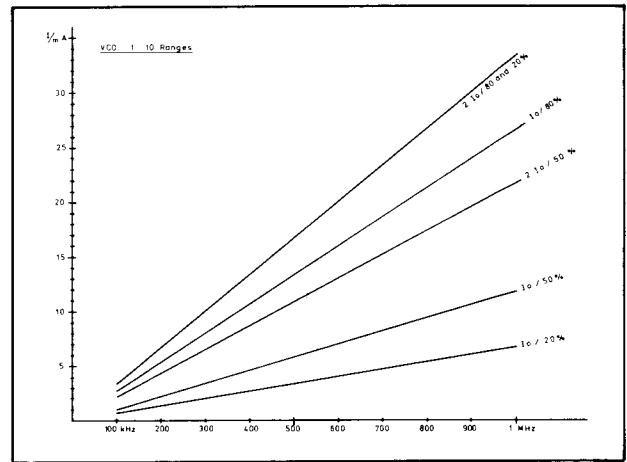

Table 8-3-5. Capacitor ranges

FRQ range	FR1	FR2	FR3	K4	K5
1 kHz – 9.999 K	1	0	0	ON	ON
10 kHz – 99.99 K	0	1	0	OFF	ON
100 kHz – 999.9 K	0	0	1	OFF	OFF
1 MHz – 50 MHz	0	0	0	OFF	OFF

Table 8-3-6. Duty cycle ranges

Triangle	1 kHz to 19.99 MHz			20 MHz - 50 MHz		
	K1	K2	K3	K1	K2	K3
20%						
50%						
80%						
Pulse						
20%						
50%						
80%						

TRIGGER, GATE, BURST-CONTROL Circuit 2B

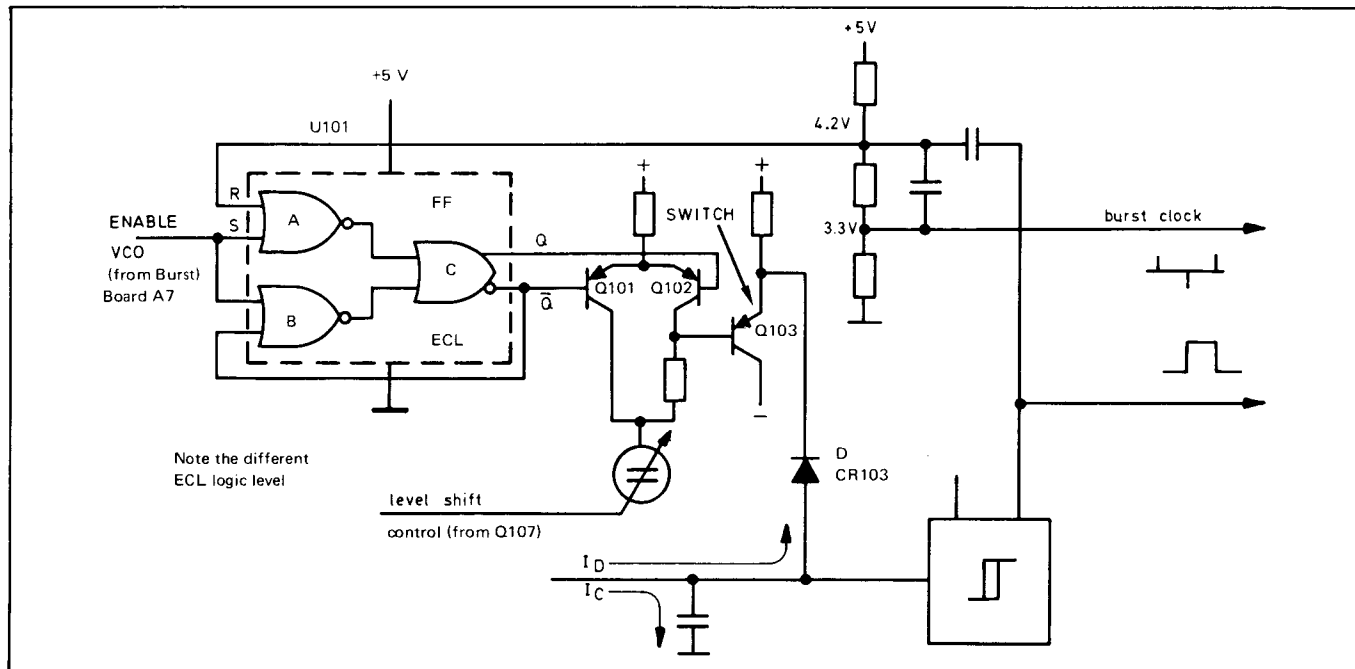

. Trigger/Gate/Burst control block diagram

Table 8-3-7. U101 Truth Table

	R	S	Q	Switch
1	H	O	I	
2	H	H	O	
3	H	O	Q	no change
4	O	O	O	

Use the truth table 8-3-7 to check out the U101/CR103 function as shown in the block diagram above and Figure 8-3-17. In NORM MODE, ENABLE VCO is kept high so Q is low which disables CR103. When set to an Ext. mode the next reset pulse will turn Q high and CR103 is enabled.

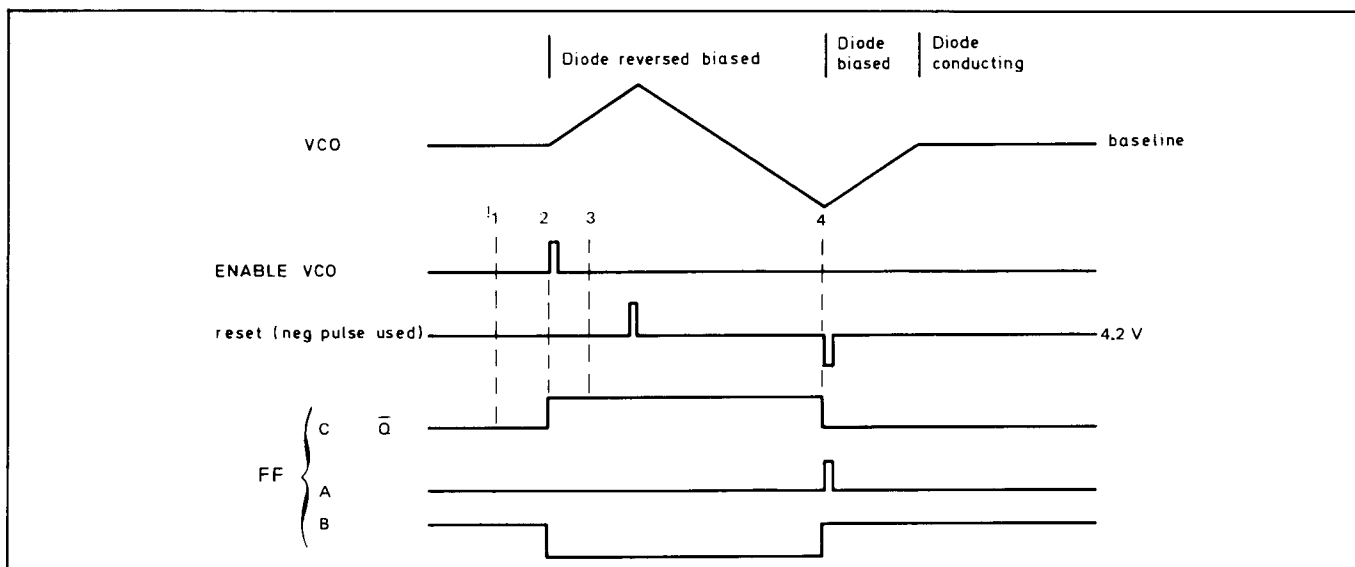

Figure 8-3-17. Timing diagram for Trigger/Gate/Burst control

SINE SHAPER, DRIVER A5

2C

Table 8-3-8. Waveform control (acceptor and latch on A8 6)

	K301	W1	K401	W2	W3	W6	W 10	K302
Sine \leq 999 Hz (LF)		0			1	0	1	
Sine \geq 1 kHz (HF)		1			1	0	1	
Triangle \leq 999 Hz (LF)				0	0	0	1	
Triangle \geq 1 kHz (HF)				1	0	0	1	
Ramp 80/20, 20/80 (LF)					0	0	1	
Ramp 20/80, 80/20 (HF)					0	0	1	
Pulse 50 % (LF)					0	1	0	
Pulse 50 % (HF)					0	1	0	
Pulse 80/20, 20/80 (LF)					0	1	0	
Pulse 80/20, 20/80 (HF)					0	1	0	
if FRQ \geq 1 MHz in NORM or VCO or SWP								

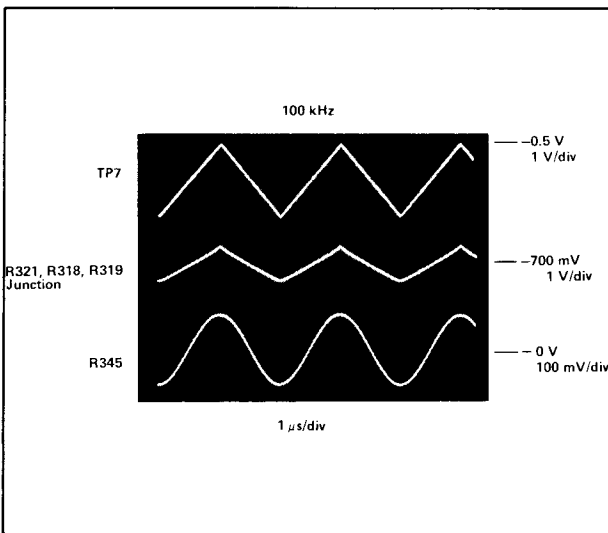

Figure 8-3-18. Sine shaper waveforms

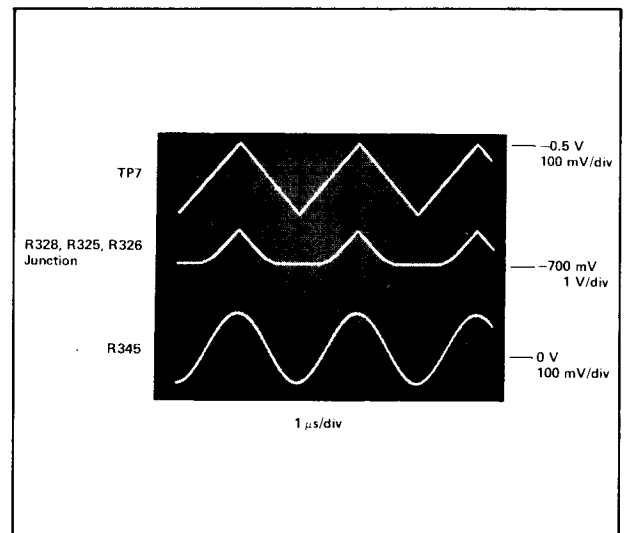

Figure 8-3-19. Sine shaper waveforms

LOW FREQUENCY GENERATOR A10

3

Divider and duty cycle troubleshooting (NORM MODE)

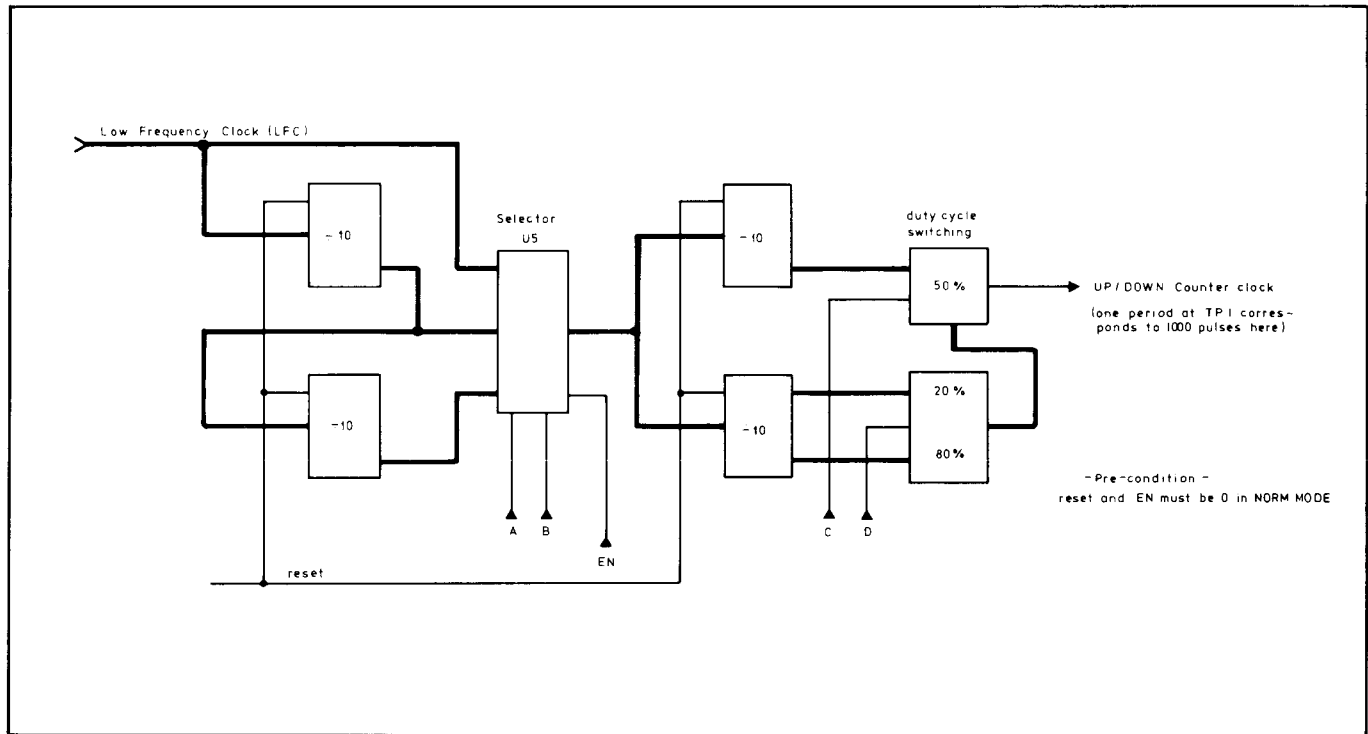

Figure 8-3-20. Block diagram of duty cycle logic

Table 8-3-9. Frequency ratio table (50 % duty cycle)

Display	VCO frq (LFC)	Selector U5 Y	A	B	Cntr clock U12/8	Output TP1
999.9 Hz	9.999 MHz	9.999 MHz	0	0	999.9 kHz	999.9 Hz
100.0 Hz	1.000 MHz	1.000 MHz	0	0	100.0 kHz	100.0 Hz
99.99 Hz	999.9 kHz	999.9 kHz	0	0	99.99 kHz	99.99 Hz
10.00 Hz	100.0 kHz	100.0 kHz	0	0	10.00 kHz	10.00 Hz
9.999 Hz	99.99 kHz	99.99 kHz	0	0	9.999 kHz	9.999 Hz
1.000 Hz	10.00 kHz	10.00 kHz	0	0	1.000 kHz	1.000 Hz
999.9 mHz	9.999 kHz	9.999 kHz	0	0	999.9 Hz	999.9 mHz
100.0 mHz	1.000 kHz	1.000 kHz	0	0	100.0 Hz	100.0 mHz
99.99 mHz	9.999 kHz	999.9 Hz	1	0	99.99 Hz	99.99 mHz
10.00 mHz	1.000 kHz	100.0 Hz	1	0	10.00 Hz	10.00 mHz
9.999 mHz	9.999 kHz	99.99 Hz	0	1	9.999 Hz	9.999 mHz
1.000 mHz	1.000 kHz	10.00 Hz	0	1	1.000 Hz	1.000 mHz

Table 8-3-10. Duty cycle switching

Mode	C	D
pulse		
80 %	1	1
20 %	1	0
ramp		
80 %	1	0
20 %	1	1

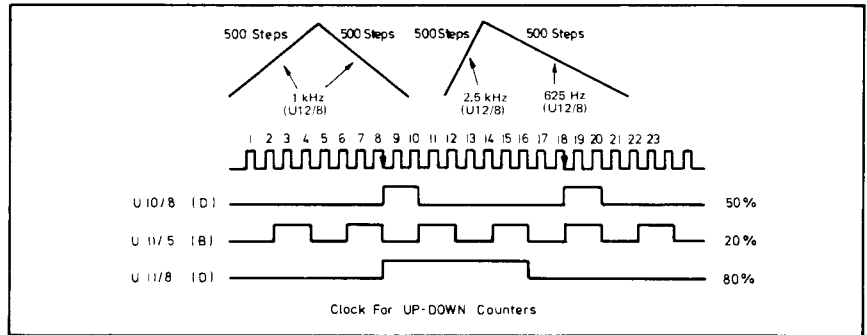

Figure 8-3-21. Example: LF Generator output 1 Hz

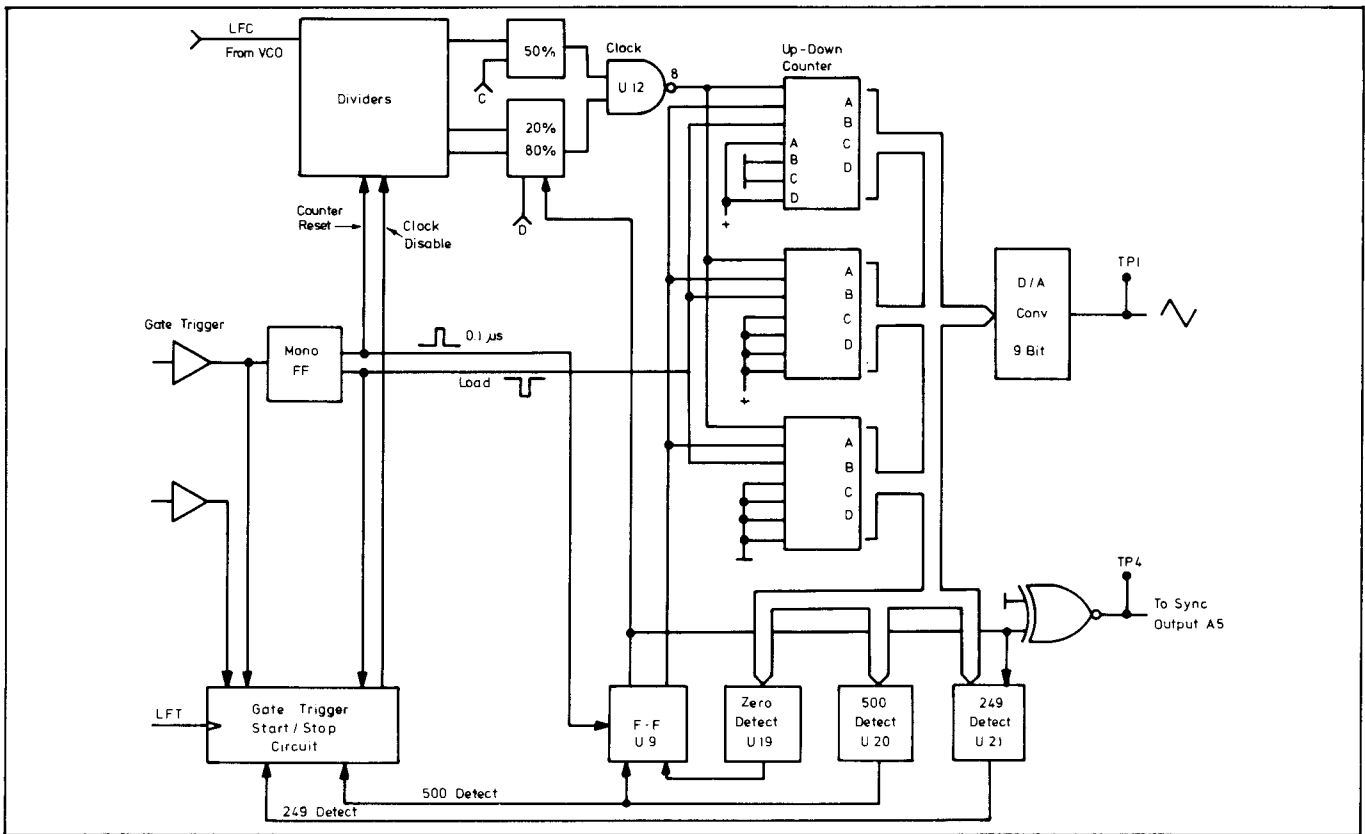

Figure 8-3-22. Block diagram of LF Generator counter

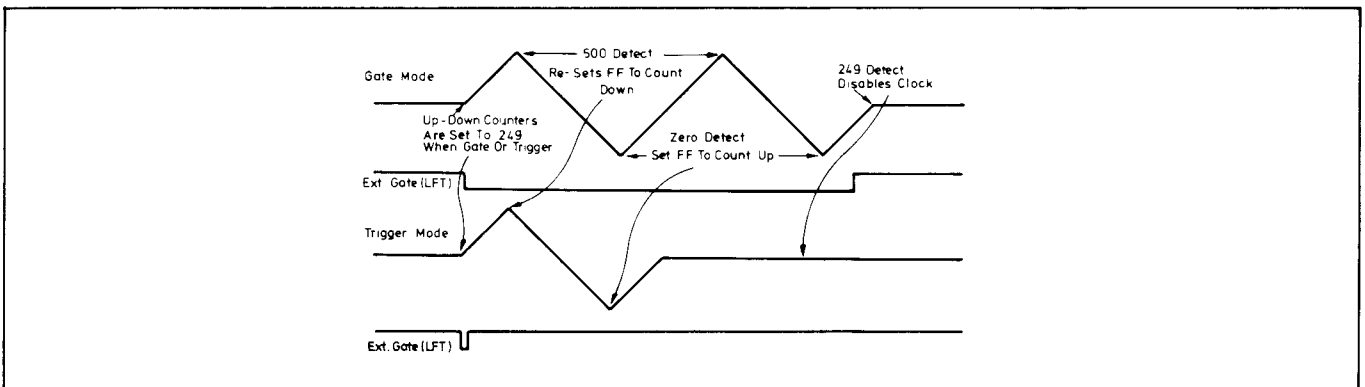

Figure 8-3-23. Timing diagram for LF Generator counter

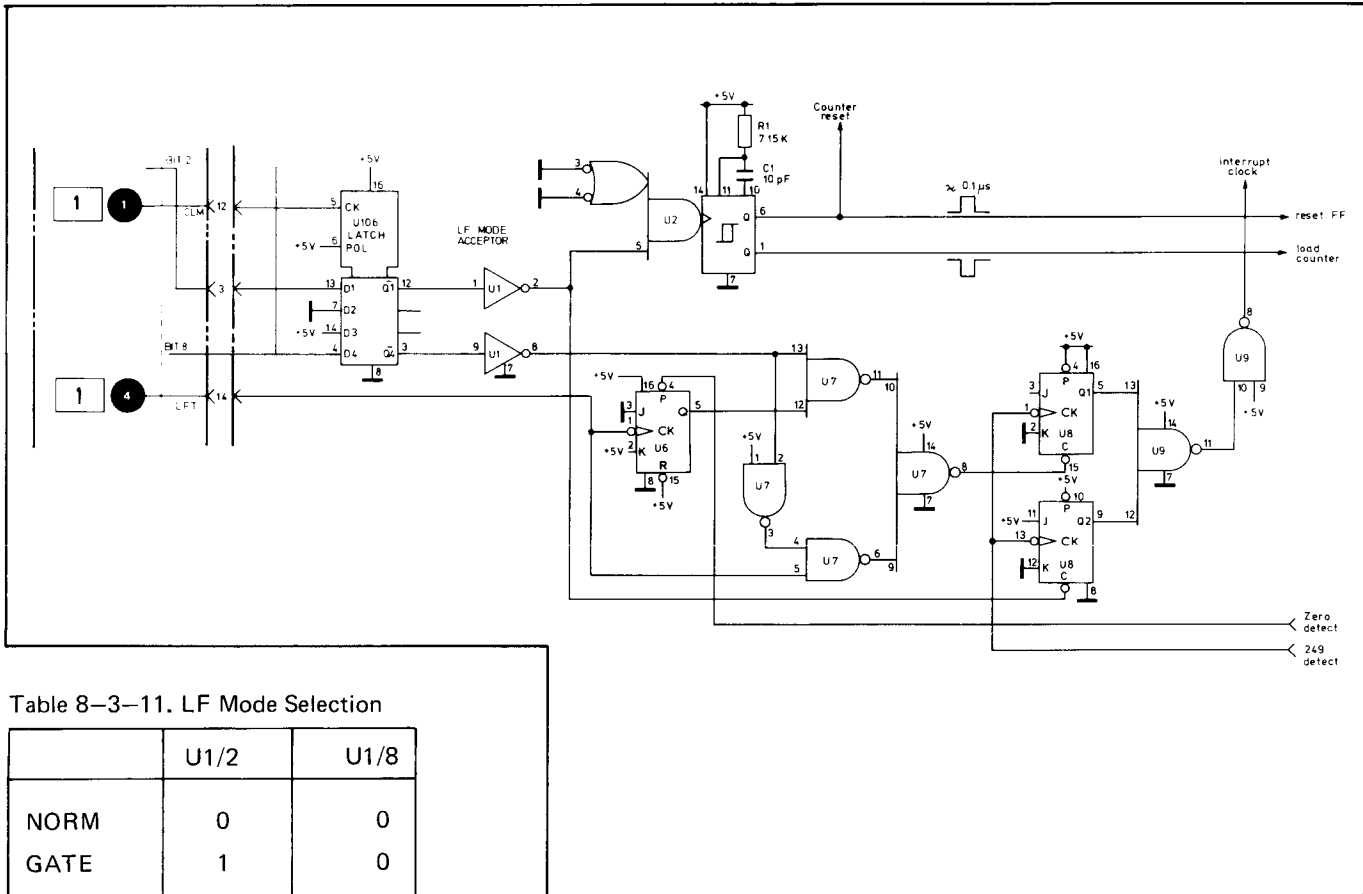

Table 8-3-11. LF Mode Selection

	U1/2	U1/8
NORM	0	0
GATE	1	0
TRIGGER	1	1

Figure 8-3-24. Start/Stop circuit for GATE, TRIGGER Mode

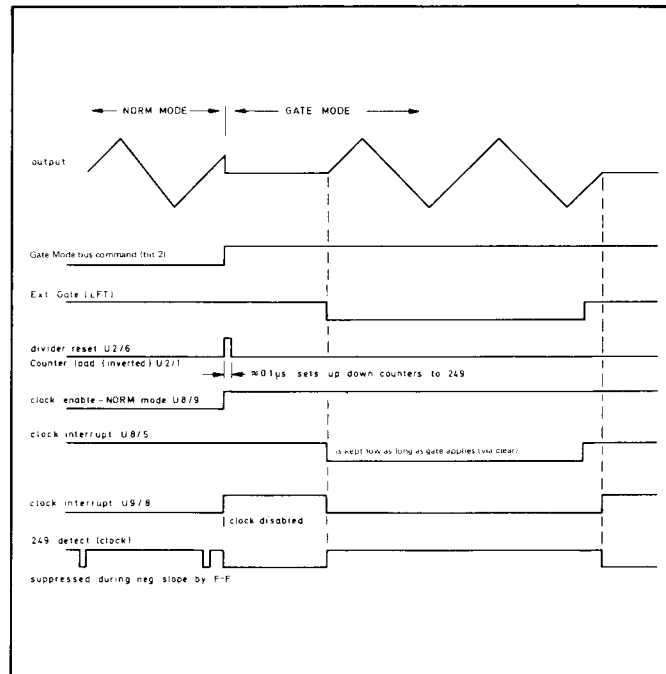
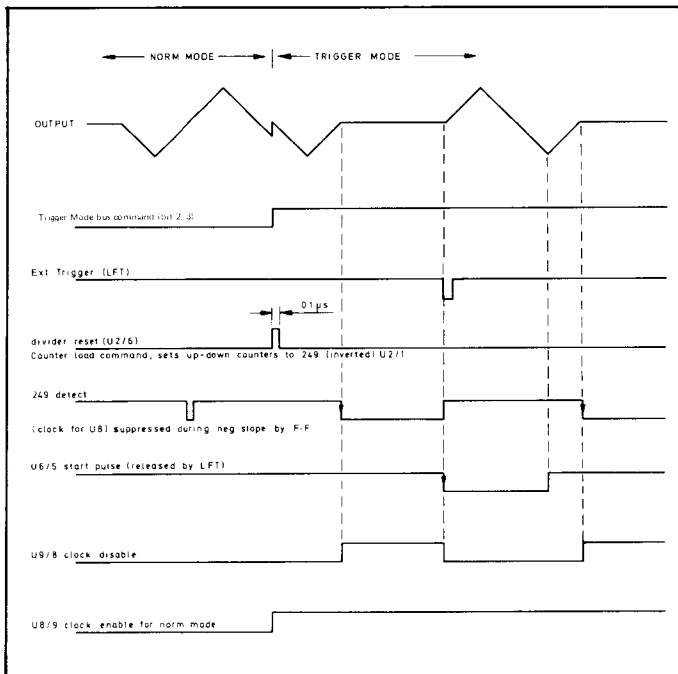

Figure 8-3-25. Trigger Mode

Figure 8-3-26. Gate Mode

PLL REFERENCE DIVIDERS A9

5A

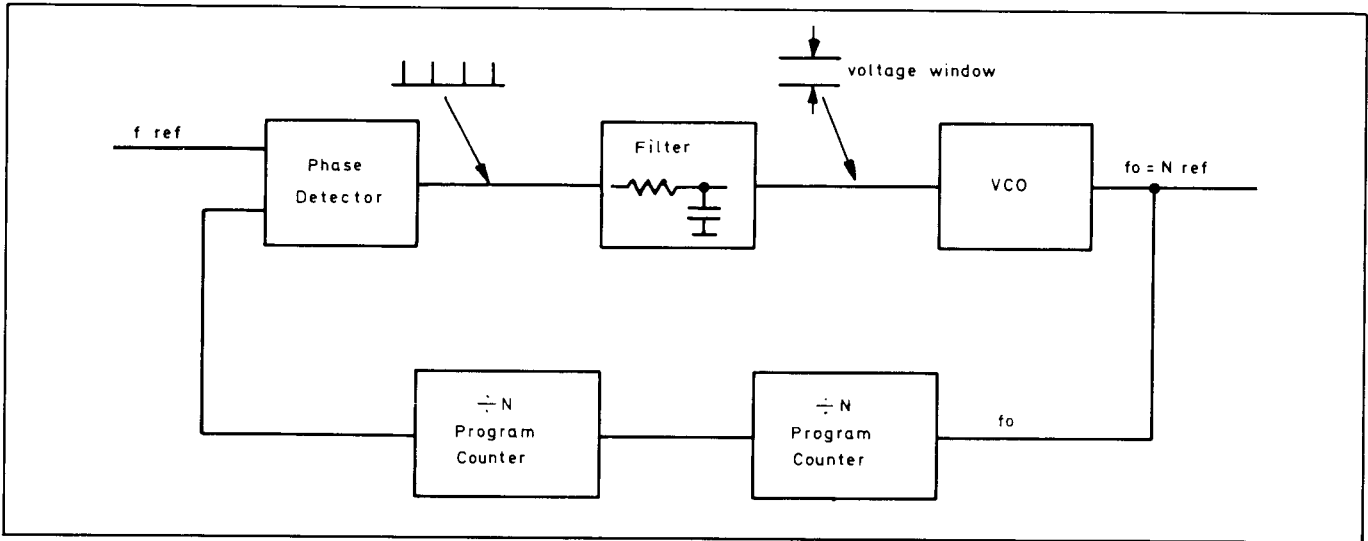

Figure 8-3-27. PLL Block diagram

Table 8-3-12. Loop 1 (XX00-XX99) 95 kHz – 540 kHz

Displ.	bit Ofl.	16	15	14	13	12	11	10	9	frequ.	Input Voltage VCO	Divider Ratio $\div N$
1000	0	0	0	0	1	1	0	0	1	95 K	$\approx 2.12 \text{ V}$	19
1100	0	0	0	1	0	0	0	0	0	100 K		20
1200	0	0	0	1	0	0	0	0	1	105 K		21
1300	0	0	0	1	0	0	0	1	0	110 K		22
1400	0	0	0	1	0	0	0	1	1	115 K		23
1500	0	0	0	1	0	0	1	0	0	120 K		24
1600	0	0	0	1	0	0	1	0	1	125 K		25
1700	0	0	0	1	0	0	1	1	0	130 K		26
1800	0	0	0	1	0	0	1	1	1	135 K		27
1900	0	0	0	1	0	1	0	0	0	140 K		28
2000	0	0	0	1	0	1	0	0	1	145 K		29
2100	0	0	0	1	1	0	0	0	0	150 K		30
2200	0	0	0	1	1	0	0	0	1	155 K		31
2500	0	0	0	1	1	0	1	0	0	170 K		34
3000	0	0	0	1	1	1	0	0	1	195 K		39
4000	0	0	1	0	0	1	0	0	1	245 K		49
5000	0	0	1	0	1	1	0	0	1	295 K		59
6000	0	0	1	1	0	1	0	0	1	345 K		69
7000	0	0	1	1	1	1	0	0	1	395 K		79
8000	0	1	0	0	0	1	0	0	1	445 K		89
9000	0	1	0	0	1	1	0	0	1	495 K		99
9100	1	0	0	0	0	0	0	0	0	500 K		100
9200	1	0	0	0	0	0	0	1	0	505 K	101	
9300	1	0	0	0	0	0	1	0	0	510 K	102	
9400	1	0	0	0	0	0	1	1	0	515 K	103	
9500	1	0	0	0	0	1	0	0	0	520 K	104	
9600	1	0	0	0	0	1	0	1	0	525 K	105	
9700	1	0	0	0	0	1	1	0	0	530 K	106	
9800	1	0	0	0	0	1	1	1	0	535 K	107	
9900	1	0	0	0	0	1	0	0	0	540 K	108	

Voltage variation about 5.36 V

$\approx 7.48 \text{ V}$

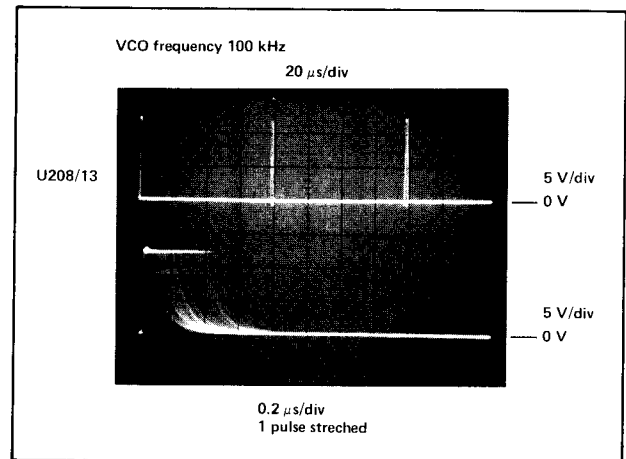

Figure 8-3-28. Waveform loop 1

Max. and min. frequency of Loop 1 can be tested by shorting CR201, CR202.

Procedure:

short CR201. Frequency should be $< 50 \text{ kHz}$ at Q202c.

short CR202. Frequency should now be $> 800 \text{ kHz}$. (*C205)

Table 8-3-13. Loop 2 (10XX-99XX) 8.01 MHz – 9.00 MHz

displ.	bit			frequ.	Input Voltage VCO	Divider Ratio	
	8	7	6				5
1000	0	0	0	0	9.00 M	900	
1001	0	0	0	0	8.99 M	899	
1002	0	0	0	0	8.98 M	898	
1003	0	0	0	0	8.97 M	897	
1004	0	0	0	0	8.96 M	896	
1005	0	0	0	0	8.95 M	895	
1006	0	0	0	0	8.94 M	894	
1007	0	0	0	0	8.93 M	893	
1008	0	0	0	0	8.92 M	892	
1009	0	0	0	0	8.91 M	891	
1010	0	0	0	1	8.90 M	890	
1011	0	0	0	1	8.89 M	889	
1012	0	0	0	1	8.88 M	888	
1015	0	0	0	1	8.85 M	885	
1020	0	0	1	0	8.80 M	880	
1030	0	0	1	1	8.70 M	870	
1040	0	1	0	0	8.60 M	860	
1050	0	1	0	1	8.50 M	850	
1060	0	1	1	0	8.40 M	840	
1070	0	1	1	1	8.30 M	830	
1080	1	0	0	0	8.20 M	820	
1090	1	0	0	1	8.10 M	810	
1091	1	0	0	1	8.09 M	809	
1092	1	0	0	1	8.08 M	808	
1093	1	0	0	1	8.07 M	807	
1094	1	0	0	1	8.06 M	806	
1095	1	0	0	1	8.05 M	805	
1096	1	0	0	1	8.04 M	804	
1097	1	0	0	1	8.03 M	803	
1098	1	0	0	1	8.02 M	802	
1099	1	0	0	1	8.01 M	801	

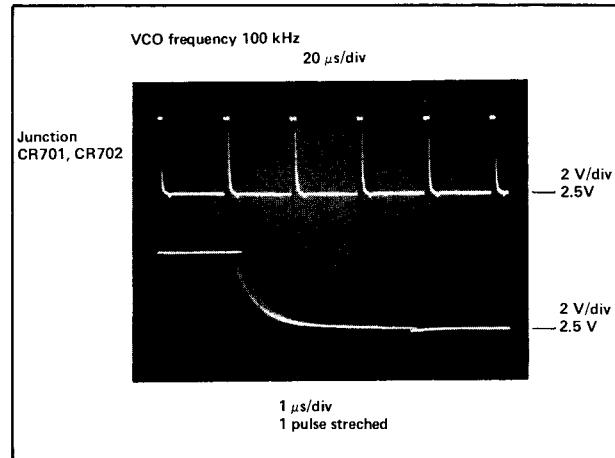

Figure 8-3-29. Waveform loop 2

Max. and min. frequency of Loop 2 can be tested by shortening R703, R704.

Procedure:

short R703. Frequency at U708/6 should be < 7 MHz.

short R704. Frequency should be > 11.5 MHz and < 14 MHz (*C704).

PLL MIXER AND FEEDBACK DIVIDERS A9 5B

Note the ± 17 V supplies for the ramp generator and ± 3.2 V supplies for the sine shaper. The PLL feedback is always between 1.00 kHz and 9.99 kHz. The control voltage (DVO) is always between 0.5 V and 4.9 V depending on frequency display. The frequency feedback (Q305, Q306) is always 50 % duty cycle.

Table 8-3-14. Divider settings

Range	TP4 frequency	step 2 of the freq. transfer block U105, U106 bit pattern							
		bit 6	5	4	3	2	1		
1 mHz – 9.999 mHz	1 KHz – 10 KHz	}	action on A3 LF Gen. only (bit 13, 14) 10^0	0	1	0	0	0	0
10 mHz – 99.99 mHz	1 KHz – 10 KHz			0	0	1	0	0	0
100 mHz – 999.9 mHz	1 KHz – 10 KHz			0	0	0	1	0	0
1 Hz – 9.999 Hz	1 KHz – 10 KHz	0	0	1	0	0	0	(10^1)	
10 Hz – 99.99 Hz	1 KHz – 10 KHz	0	0	0	1	0	0	(10^2)	
100 HZ – 999.9 Hz	1 KHz – 10 KHz	0	0	0	0	1	0	(10^3)	
1 KHz – 9.999 KHz	1 KHz – 10 KHz	0	1	0	0	0	0	(10^0)	
10 KHz – 99.99 KHz	1 KHz – 10 KHz	0	0	1	0	0	0	(10^1)	
100 KHz – 99.9 KHz	1 KHz – 10 KHz	0	0	0	1	0	0	(10^2)	
1 MHz – 9.999 KHz	1 KHz – 10 KHz	0	0	0	0	1	0	(10^3)	
10 MHz – 50.00 MHz (50% duty cycle)	1 KHz – 5 KHz	0	0	0	0	0	1	(10^4)	

bit 6 indicates an overflow of the first two digits of display. Will be 0 until 90 and goes high from 91 to 99.

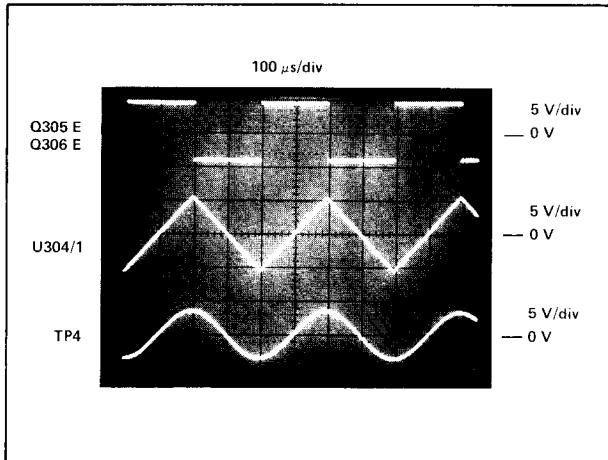

Figure 8-3-30. Waveforms (VCO freq. 100 kHz)

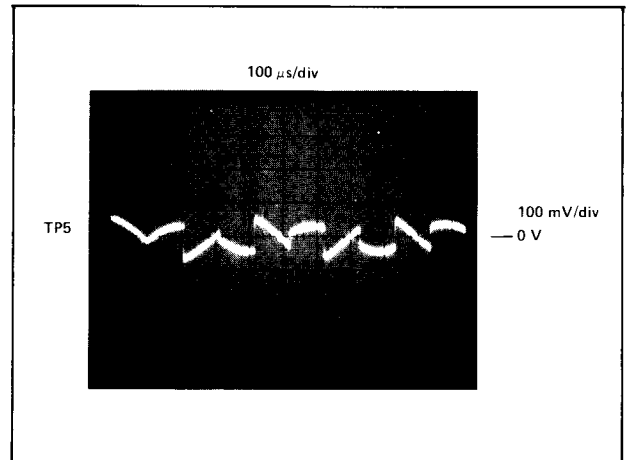
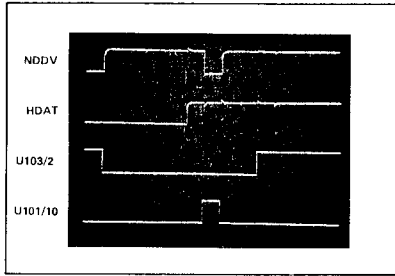

Figure 8-3-31. Waveforms (VCO freq. 100 kHz)

Waveform Acceptor A10 3
 (all signals TTL) time base 20 μ s/div



For repeating signals a controller is needed.
 Program: wrt 716, "F1"; jmp 0

Frequency Acceptor A9 5B
 (all signals TTL) time base 200 μ s/div

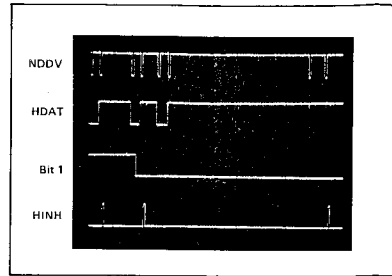

Waveform Acceptor 6
 (all signals TTL) time base 50 μ s/div

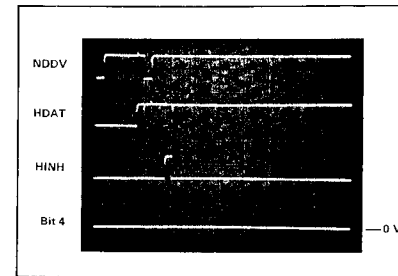

Frequency Range Acceptor 6
 (all signals TTL) time base 200 μ s/div

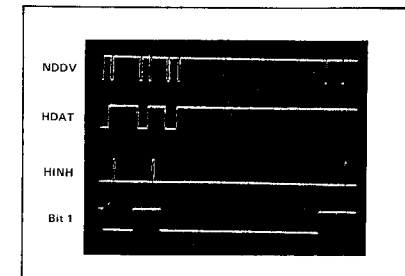

Low Frequency Acceptor A10 3
 (all signals TTL) time base 200 μ s/div

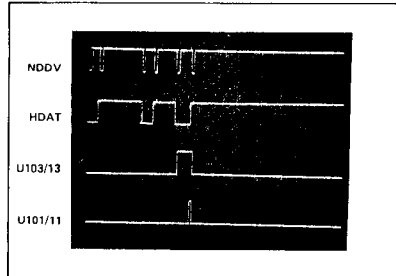

For repeating signals a controller is needed.
 Program: wrt 716, "FRQ 1 MHz"; jmp 0
 For device bus details see SERVICE BLOCK 1

In Gate or Trigger mode, CLM is generated by the INPUT MODE ACCEPTOR on Burst board A7 — see Service Block 2.

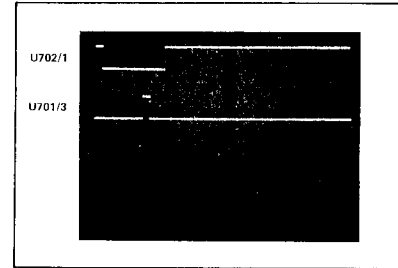
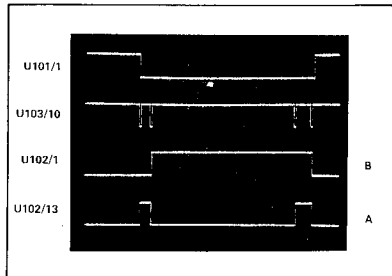

For repeating signals a controller is needed.
 Program: wrt 716, "F1" ; jmp 0
 For device bus details see SERVICE BLOCK 1.

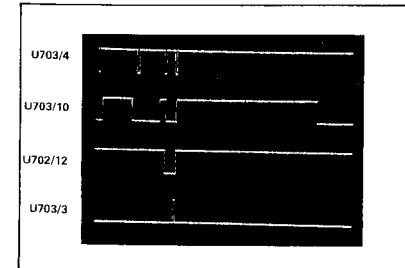

For repeating signals a controller is needed.
 Program: wrt 716, "FRQ 19.99 MHz"; jmp 0
 For device bus details see SERVICE BLOCK 1.

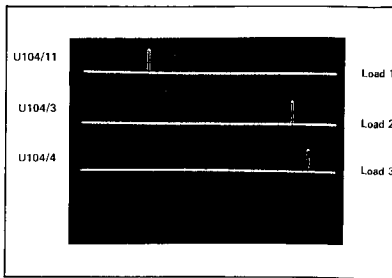

For repeating signals a controller is needed.
 Program: wrt 716, "FRQ 1 MHz"; jmp 0
 For device bus details see SERVICE BLOCK 1

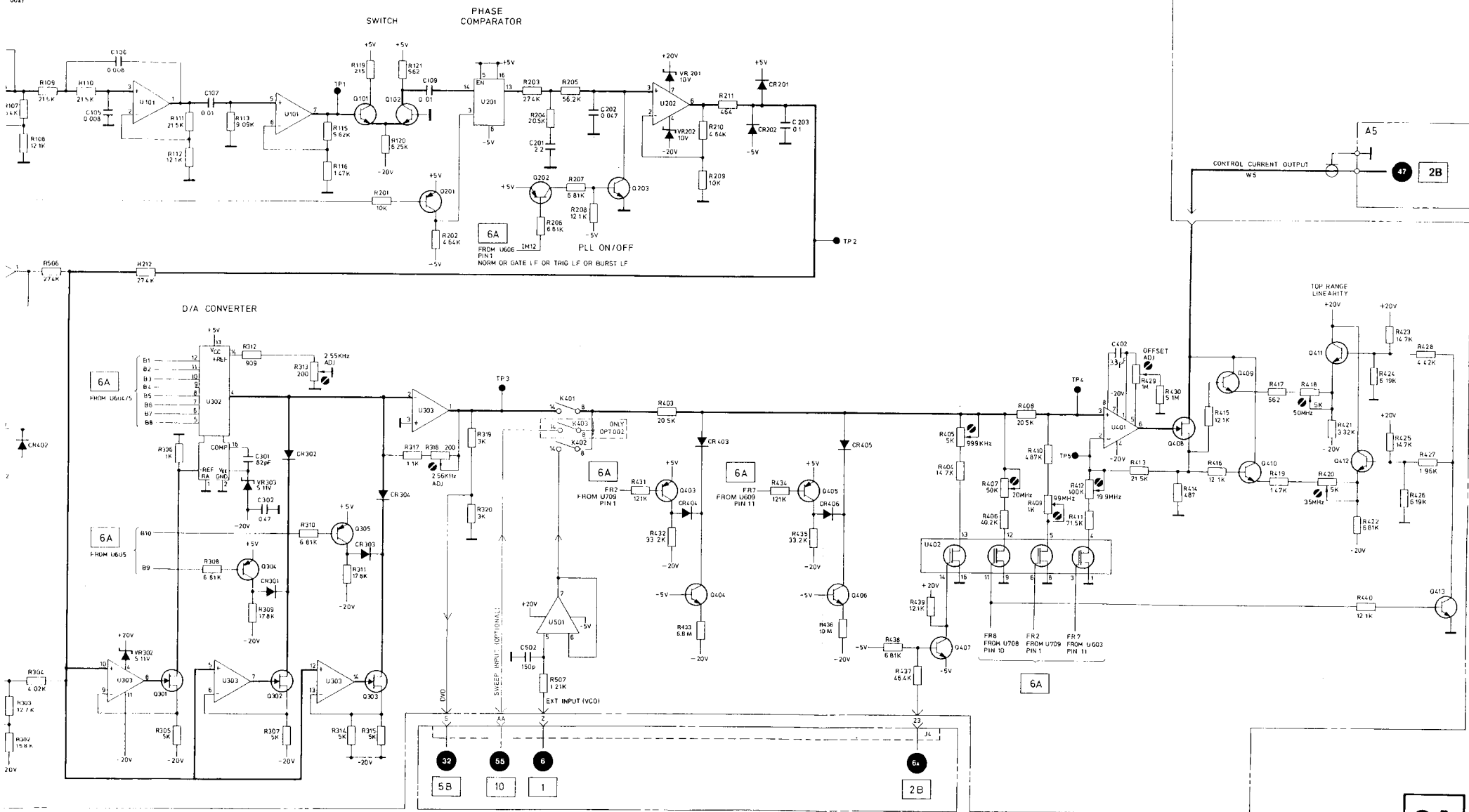

A8 VCO CONTROL

2A

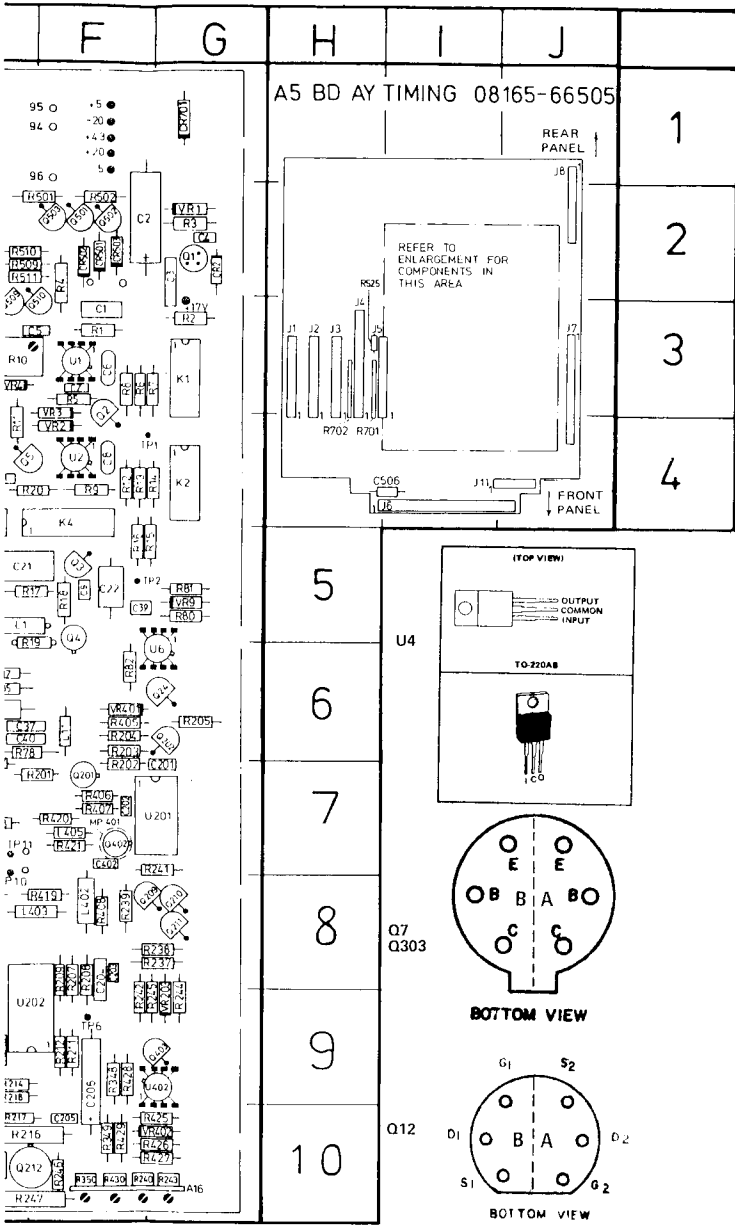

A5 BD AY TIMING 08165-66505

REF DESIG	GRID LOC	REF DESIG	GRID LOC	REF DESIG	GRID LOC	REF DESIG	GRID LOC	REF DESIG	GRID LOC	REF DESIG	GRID LOC	REF DESIG	GRID LOC	REF DESIG	GRID LOC
C1	F3	C402	F7	L403	E8	Q503	F2	R62	C6	R223	D10	R348	F9	R523	D7
C2	F2	C403	E7	L405	F7	Q504	C2	R63	C6	R224	D9	R349	F10	R524	A8
C3	G2	C404	C8	L406		Q505	C2	R64	C6	R225	D9	R351	D10	R525	H3
C4	G2	C405	D7	L501	C4	Q506	C2	R65	D6	R228	D10	R352	C10	R526	A10
C5	E3	C501	D3	MP1	D5	Q507	B2	R66	D6	R229	D10	R353	C10	R527	A10
C6	F3	C502		MP2	D6	Q508	B2	R67	A7	R231	D10	R354	C10	R528	B10
C7	F3	C503	C4	MP3	D6	Q509	E3	R68	A6	R232	E9	R355	C9/10	R601	C6/7
C8	F4	C504	C7	MP4	C6	Q510	E3	R69	B6	R233	E9	R356	C/D9	R602	B8
C9	F5	C505	D7	MP5	C6	Q511	D4	R70	B7	R234	E9	R357	D9	R603	B8
C11	E4	C506	I4	MP6	D4	Q512	E4	R71	B7	R235	E8	R358	D9	R701	H3
C12	E5	CR1	A/B/2	MP7	C5	Q513	D4	R73	D7	R236	D9	R359	C9	R702	H3
C14	E3	CR101	B5	MP301	D8	Q514	A6	R74	E6	R237	G8	R361	D9	RT1	D5
C15	B3	CR102	B5	MP302	C10	Q515	A7	R76	E6	R238	G8	R362	D9	U1	F3
C16	A2	CR103	D5	MP401	F7	Q516	A10	R77	E7	R239	F8			U2	F4
C17	E2	CR104	B3	Q1	F4	Q517	A10	R78	E6	R241	G7	R363	D9/10	U3	E3
C18	E3	CR201	E10	Q2	F4	Q518	B10	R80	G5	R242	F9	R364	D8	U4	B2
C19	D3	CR202	E10	Q3	F5	Q601	B8	R81	G5	R244	G9	R365	D9	U5	B6
C21	E5	CR203	D8	Q4	F5/6	R1	F3	R82	F6	R245	G9	R367	C8	U6	G6
C22	F5	CR204	D8	Q5	E4	R2	G3	R83	E6	R246	F10	R401	D8	U101	B5
C23	D5	CR205	D8	Q6	E5	R3	G2	R84	D6	R247	E10	R402	C8	U201	G7
C24	D5	CR301	D8	Q7	D5	R4	F3	R85	E6	R248	D8	R403	C/D7	U202	E/F/9
C25	D5	CR401	C8	Q8	C3	R5	F3	R86	D6	R301	B7	R404	D7	U301	C8
C27	C5	CR501	F2	Q9	D3	R6	F3	R87	E6	R302	B7	R405	F6	U303	A9
C28	B5	CR502	F2	Q10	D4	R7	G2	R88	D6	R303	B8	R406	F7	U304	B7
C29	B6	CR503	F2	Q12	C5	R8	F3	R101	B6	R304	C8	R407	F7	U305	B9/10
C31	C6	CR504	D2	Q13	C5	R9	F4	R102	A6	R305	C8	R408	F8	U306	D10
C32	D6	CR505	C2	Q14	C6	R10	E3	R103	A6	R306	C8	R409	E9	U401	E7
C33	B6	CR506	C2	Q16	C6	R11	E4	R105	B5	R307	B8	R410	E8	U402	G9
C34	C6	CR507	B2	Q17	D6	R12	F4	R106	A5	R308	B8	R411	E7/8	U601	A/B/7
C35	D7	CR508	D3	Q18	D6	R13	F4	R107	B4	R309	B9	R412	E7/8	VR1	G2
C36	D5	CR509	D3	Q19	D6	R14	G4	R108	B5	R310	B8	R413	E8	VR2	F4
C37	E6	CR510	D4	Q20	C6	R15	G5	R109	B5	R311	B8	R414	E7	VR3	F4
C38	E6	CR512	A6	Q21	C6	R16	F5	R110	C5	R312	B8	R415	D8	VR4	E3
C39	F5	CR513	B10	Q22	D6	R17	E5	R111	C5	R313	B8	R416	D/E1	VR5	C3
C40	E6	CR514	A7	Q23	E6	R18	F5	R112	C5	R314	B8	R417	E8	VR6	A/B/6
C41	B6	CR601	A8	Q24	G6	R19	E6	R115	B3	R315	B8	R418	E7	VR7	D6
C101	B6	CR701	G2	Q25	E6	R20	E4	R116	B3	R316	A9	R419	F8	VR8	D6
C102	A6	J1	H3	Q101	B4	R21	E4	R117	B4	R317	C8	R420	F7	VR9	G5
C103	B6	J2	H3	Q102	B5	R22	E5	R118	B3	R318	C8	R421	F7	VR101	B4/5
C104	A5	J3	H3	Q103	C5	R23	E5	R119	B3	R319	C8	R425	G10	VR102	B5
C105	B5	J4	H3	Q105	B4	R24	E5	R120	A4	R320	C9	R426	G10	VR103	C5
C106	B5	J5	A7	Q106	B4	R25	D5	R121	A3	R321	B9	R427	G10	VR104	B4
C107	B5	J6	I4	Q107	B3	R26	C3	R122	C4	R322	B8	R428	F9	VR201	E9
C201	G7	J7	J3	Q108	B3	R27	C3	R123	C3	R323	A9	R429	F10	VR202	E9/10
C202	F7	J8	J2	Q109	D2	R28	E3	R124	C2	R324	B9	R431	D8	VR203	G9
C203	F8	J9	J4	Q109	F7	R29	E2	R125	C2	R325	B9	R432	D7	VR301	A10
C204	F8	K1	G3	Q202	G6	R31	D3	R126	D2	R326	B9	R432	D7	VR302	D1C
C205	F10	K2	G4	Q203	E10	R32	D3	R201	E7	R327	B9	R501	E/F/2	VR401	F6
C206	F9	K3	D2	Q204	E10	R34	D2	R202	F7	R328	B9	R502	F2	VR402	G10
C207	E9	K4	F4	Q205	D9	R36	E2	R203	F6	R329	A9	R503	E2	Z1	A/B/2
C208	D8	K5	E4	Q206	D9	R38	E2	R204	F6	R330	B9	R504	C2		
C210	E8	K301	C7	Q207	E9	R40	D3	R205	C6	R331	C9	R505	C2	TP1	F4
C211	D8	K302	B10	Q208	D8	R41	D3	R207	F8	R332	C9	R506	C2	TP2	F5
C212	E10	K401	C7	Q209	G8	R42	C3	R208	F8	R333	C9	R507	B/C2	TP3	E3
C301	C7	L1	E5	Q210	G8	R43	C3	R209	F8	R334	C8	R508	B2	TP4	D3
C302	B8	L2	E5	Q211	G8	R45	E4	R210	E9	R335	B9	R509	E2	TP5	C6
C303	B8	L3	E6	Q212	E10	R50	D5	R211	F9	R336	A/B/9	R510	E2	TP6	F9
C304	B9	L5	B5	Q301	C6	R51	D4	R212	F9	R337	A9	R511	E2	TP7	C7
C305	C9	L7	D6	Q302	C10	R52	C5	R213	E8	R338	A10	R512	E3/4	TP8	D8
C306	A9	L8	D6	Q303	D8	R53	C6	R214	E9	R339	A10	R513	E3	TP9	D7
C307	B9	L9	D6	Q304	E10	R54	B5	R215	E9	R341	A10	R514	E4	TP10	E7
C308	D9	L10	E6	Q401	D8	R55	C5	R216	E10	R342	C9	R515	E4	TP11	E7
C309	D9	L11	F6	Q402	F7	R56	C6	R217	E10	R343	C8	R516	E4		
C310	D9	L201	D8	Q403	G9	R57	C6	R218	E9	R344	C8	R517	E4		
C311	C7	L301	D8	Q404	D8	R58	C6	R219	E9	R345	C9	R520	C7		
C401	C8	L302	C8	Q501	F2	R60	D5	R220	E10	R346	B8	R521	A6		
		L401	C7	Q502	F2	R61	A6	R221	D10	R347	C6/7	R522	B10		
		L402	FB												

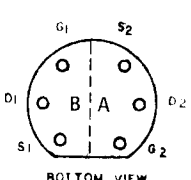
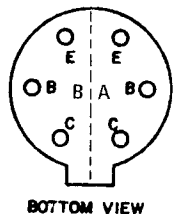

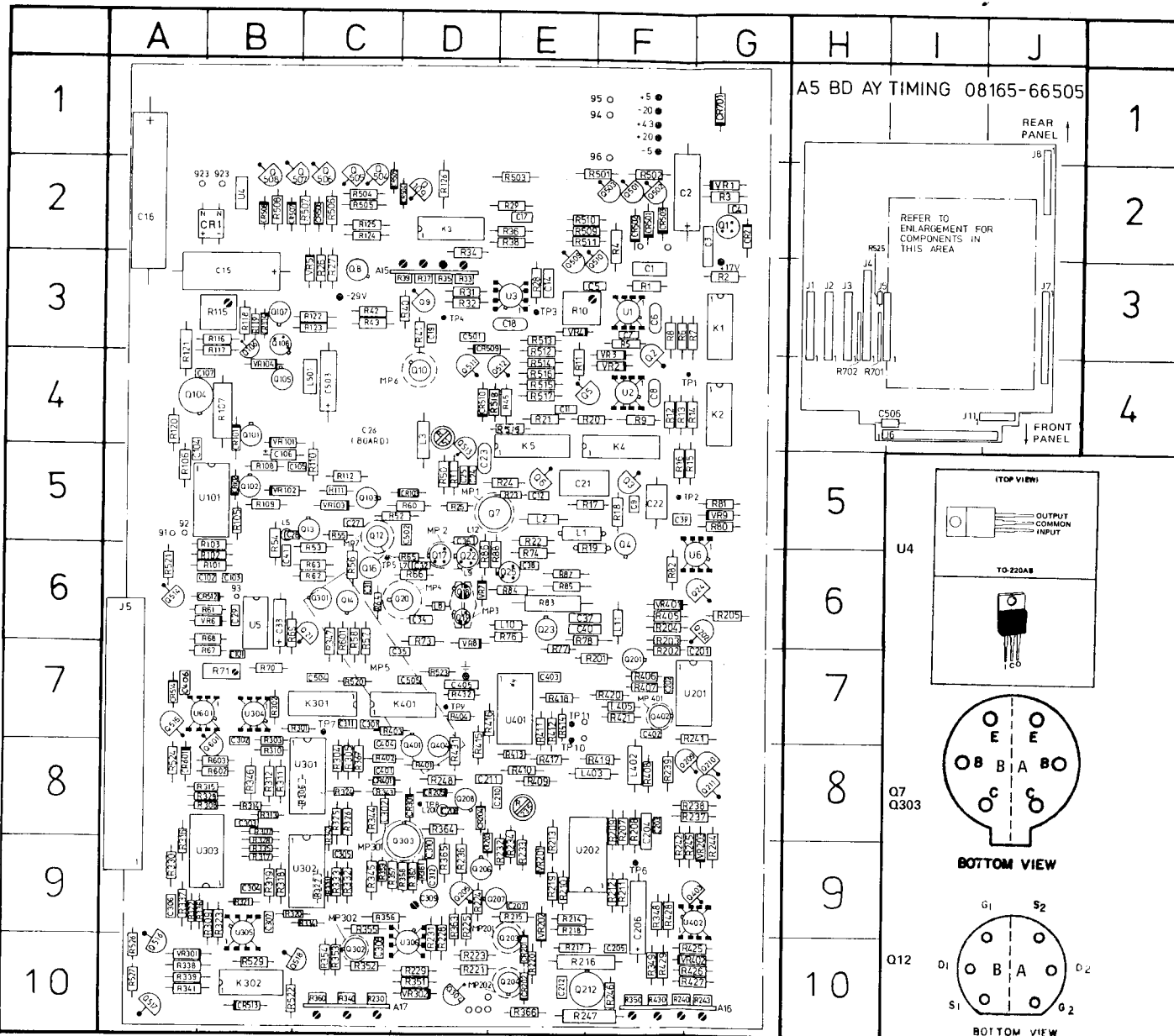

A5 BD AY TIMING 08165-66505

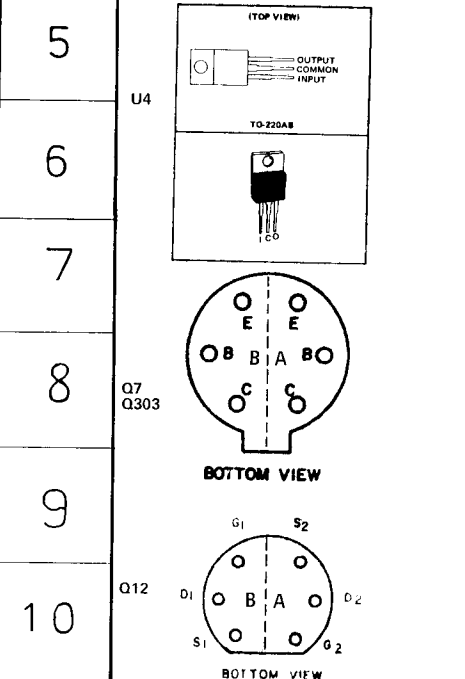
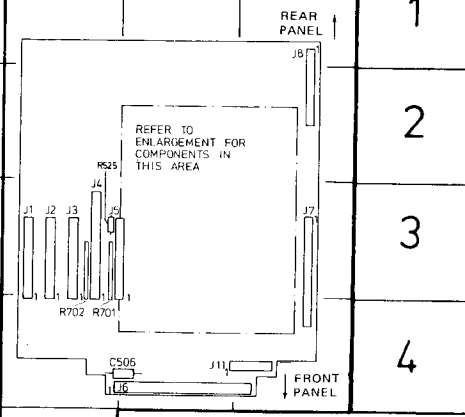

REF DESIG	GRID LOC	REF DESIG	GRID LOC	REF DESIG	GRID LOC	REF DESIG	GRID LOC
C1	F3	C402	F7	L403	E8	O503	F2
C2	F2	C403	E7	L405	F7	O504	C2
C3	G2	C404	C8	L406	C4	O505	C2
C4	G2	C405	D7	L501	C4	O506	C2
C5	E3	C501	D3	MP1	D5	O507	B2
C6	F3	C502	MP2	MP2	D6	O508	B2
C7	F3	C503	C4	MP3	D6	O509	E3
C8	F4	C504	C7	MP4	C8	O510	E3
C9	F5	C505	D7	MP5	C6	O511	D4
C11	E4	C506	I4	MP6	D4	O512	E4
C12	E5	CR1	A/82	MP7	C5	O513	D4
C14	E3	CR101	B5	MP301	D8	O514	A6
C15	B3	CR102	B5	MP302	C10	O515	A7
C16	A2	CR103	D5	MP401	F7	O516	A10
C17	E2	CR104	B3	Q1	G2	O517	B8
C18	E3	CR201	E10	Q2	F4	O518	B10
C19	D3	CR202	E10	Q3	F5	O601	R1
C21	E5	CR203	D8	Q4	F5/6	R1	F3
C22	F5	CR204	D8	Q5	E4	R2	G3
C23	D5	CR205	D8	Q6	E5	R3	G2
C24	D5	CR301	D8	Q7	D5	R4	F3
C25	D5	CR401	C8	Q8	C3	R5	F3
C27	D5	CR501	F2	Q9	D3	R6	F3
C28	B5	CR502	F2	Q10	D4	R7	G2
C29	B6	CR603	F2	Q12	C5	R8	F3
C31	C6	CR604	D2	Q13	C5	R9	F4
C32	D6	CR605	C2	Q14	C6	R10	E3
C33	B6	CR606	C2	Q16	C6	R11	E4
C34	C6	CR607	B2	Q17	D6	R12	F4
C35	D7	CR608	B2	Q18	D6	R13	F4
C36	D5	CR509	D3	Q19	D6	R14	G4
		CR510	D4	Q20	C8	R15	G5
		CR512	A6	Q21	C8	R16	F5
C37	E6	CR513	B10	Q22	D6	R17	F5
C38	E6	CR514	A7	Q23	E6	R18	F5
C39	F5	CR601	A8	Q24	G6	R19	E6
C40	E6	CR701	G2	Q25	E6	H20	E4
C41	B6	J1	H3	Q101	B4	R21	E4
C101	B6	J2	H3	Q102	B5	R22	E5
C102	A6	J3	H3	Q103	C5	R23	E5
C103	B6	J4	H3	Q105	A4	R24	E6
C104	A5	J5	A7	Q106	A4	R25	D5
C105	B5	J6	I4	Q107	B3	R26	C3
C106	B5	J7	J3	Q108	B3	R27	C3
C107		J8	J2	Q109	D2	R28	E3
C201	G7	J11	J4	Q201	F7	R29	E2
C202	F7	K1	G3	Q202	G6	R31	D3
C203	F8	K2	G4	Q203	E10	R32	D3
C204	F8	K3	D2	Q204	E10	R34	D2
C205	F10	K4	F4	Q205	D9	R36	E2
C206	F9	K5	E4	Q206	D9	R38	E2
C207	E9	K301	C7	Q207	E9	R40	D3
C208	D8	K302	B10	Q208	D8	R41	D3
C210	E8	K401	C7	Q209	G8	R42	C3
C211	D8	L1	E5	Q210	G8	R43	C3
C212	E10	L2	E5	Q211	G8	R45	E4
C301	C7	L3	E6	Q212	E10	R50	D5
C302	B8	L5	B5	Q301	C6	R51	D4
C303	B8	L7	D6	Q302	C10	R52	C5
C304	B9	L8	D6	Q303	D8	R53	C6
C305	C9	L9	D6	Q304	E10	R54	B5
C306	A9	L10	E6	Q401	D8	R55	C5
C307	B9	L11	F6	Q402	F7	R56	C6
C308	C10	L201	D8	Q403	G9	R57	C6
C309	D9	L301	D8	Q404	D8	R58	C6
C310	D9	L302	C8	Q501	F2	R60	D5
C311	C7	L401		Q502	F2	R61	A6
C401	C8	L402	F8				

2B

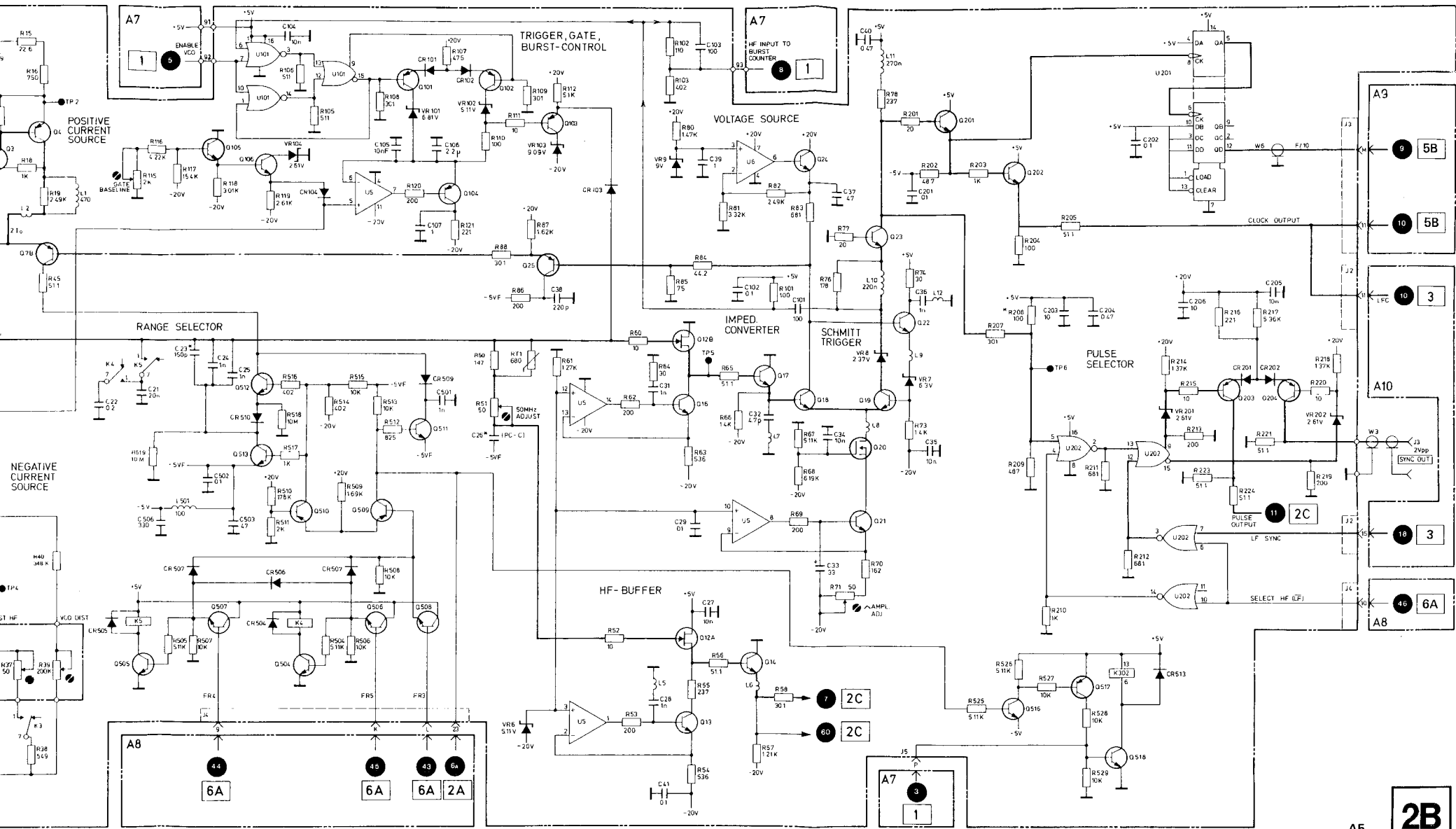

A5
VCO

2B

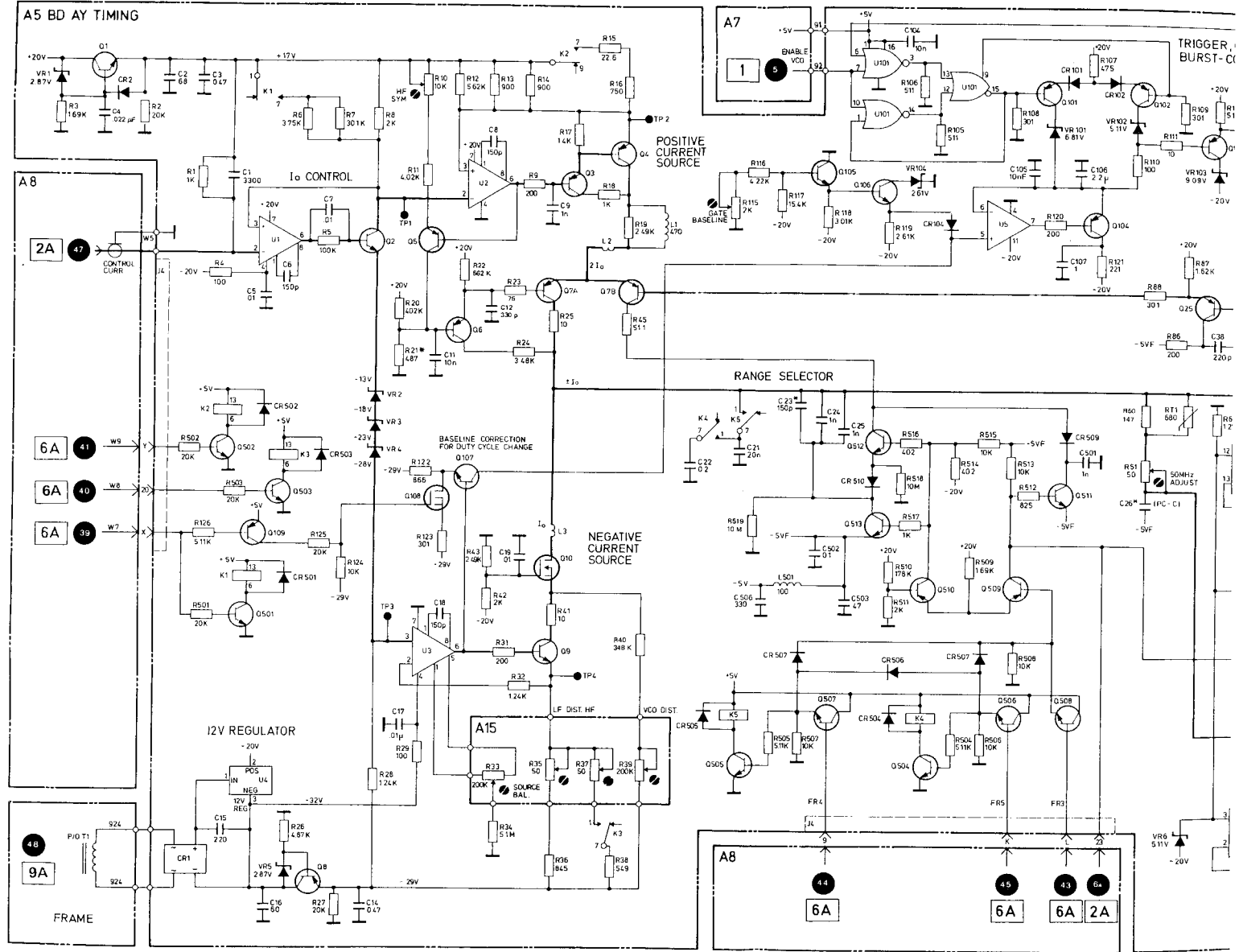

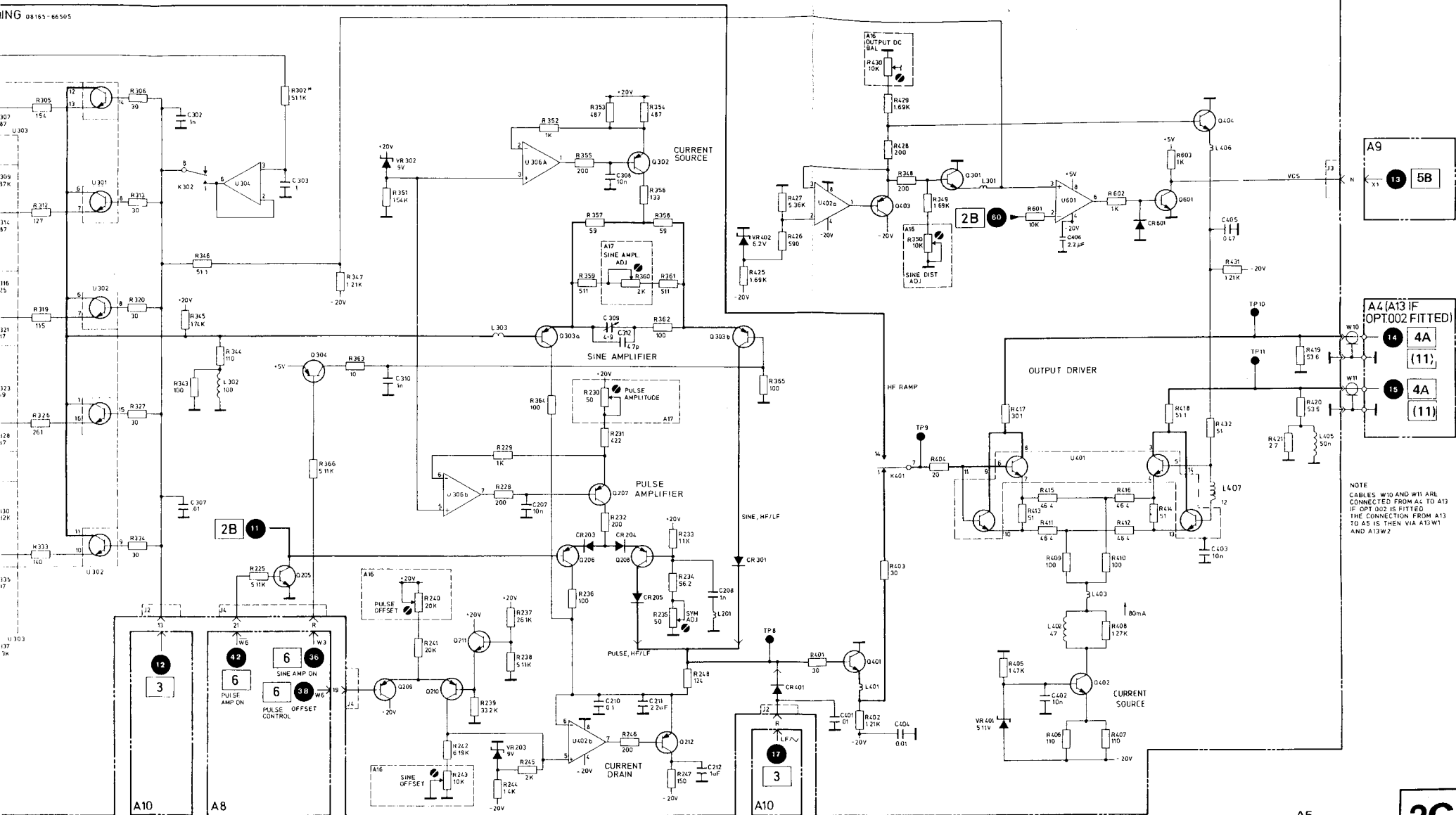

A9

13 5B

A4 (A13 IF OPT002 FITTED)

14 4A

(11)

15 4A

(11)

NOTE
CABLES W10 AND W11 ARE
CONNECTED FROM A4 TO A13
IF OPT 002 IS FITTED
THE CONNECTION FROM A13
TO A5 IS THEN VIA A13W1
AND A13W2

A5
SINE SHAPER
DRIVER

2C

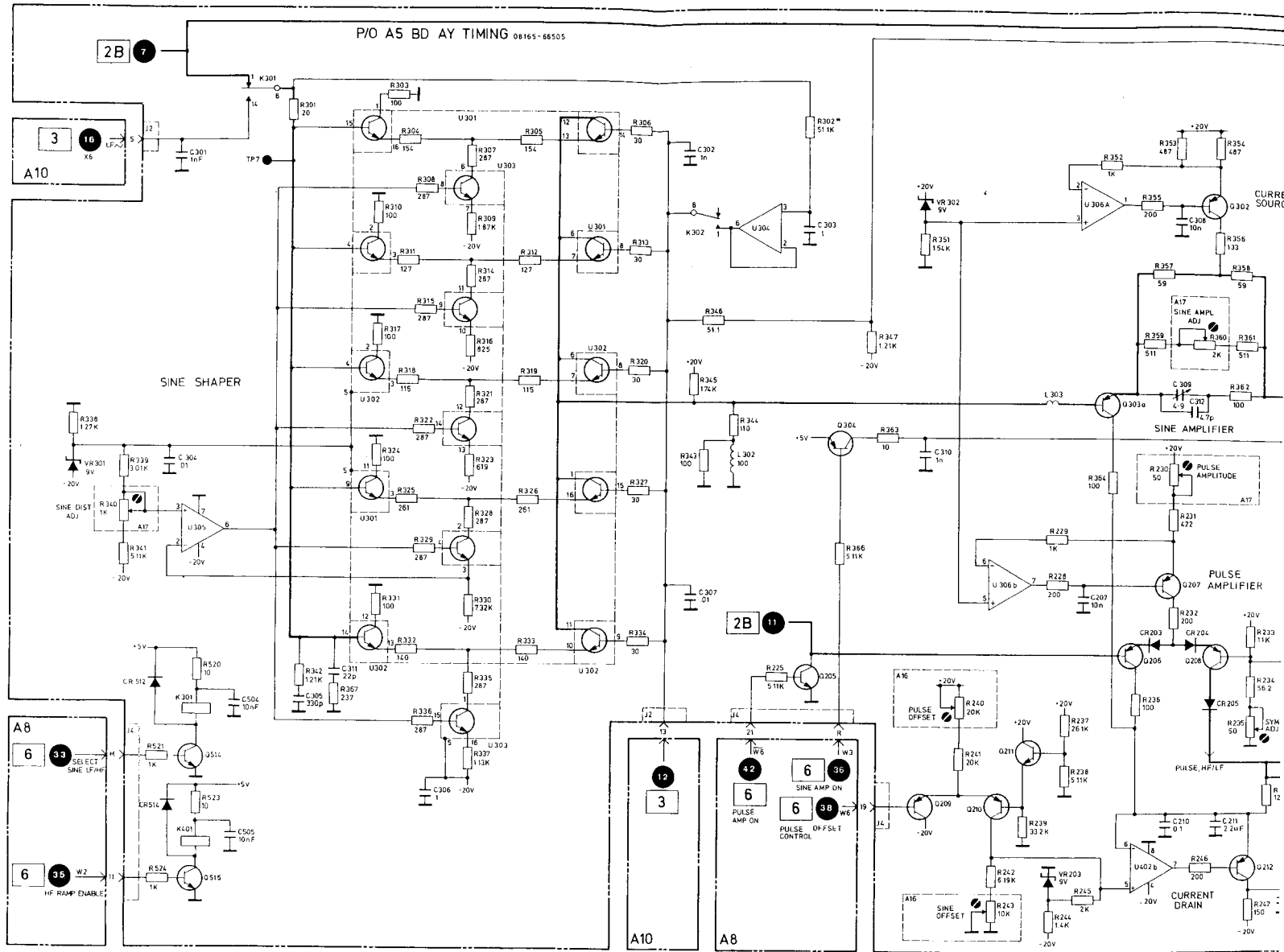

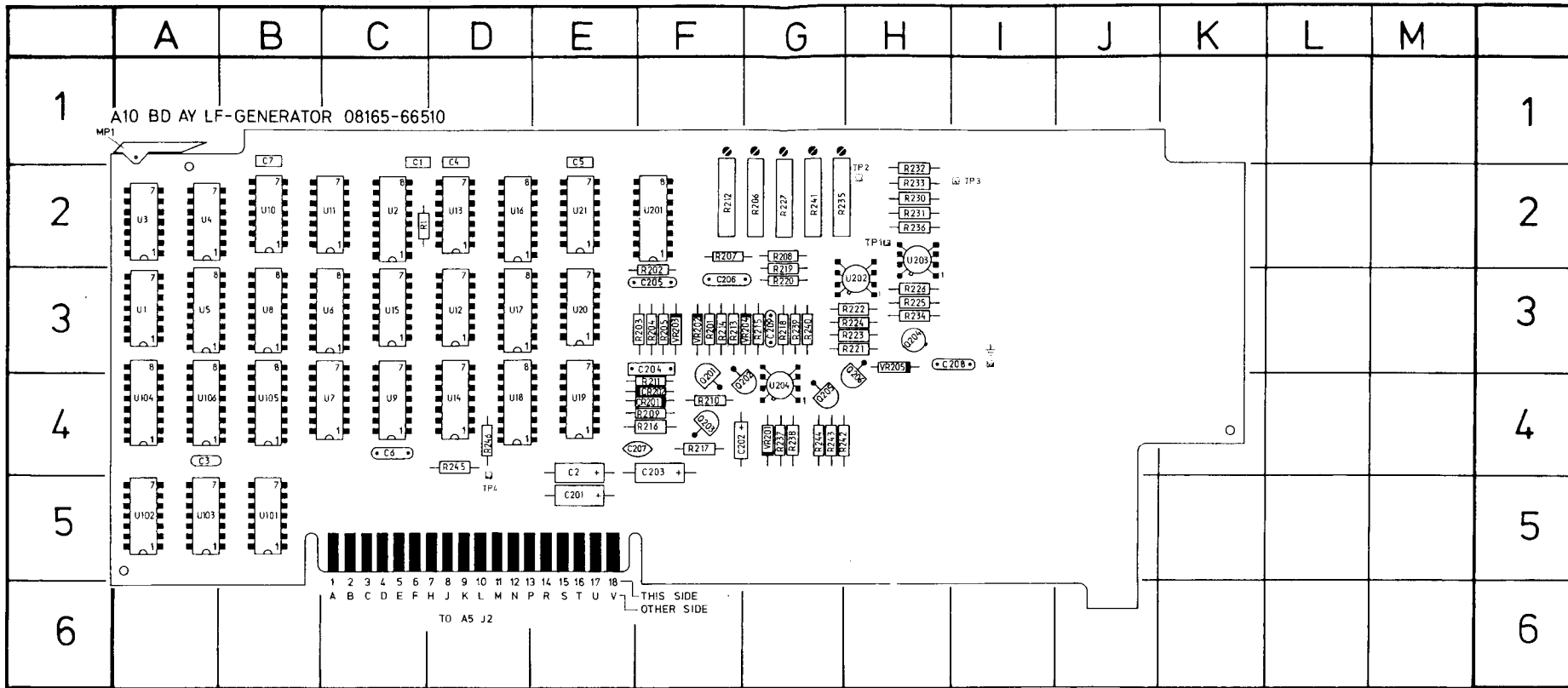

3

REF DESIG	GRID LOC	REF DESIG	GRID LOC	REF DESIG	GRID LOC	REF DESIG	GRID LOC	REF DESIG	GRID LOC	REF DESIG	GRID LOC	REF DESIG	GRID LOC
C1	C2	C207	F4	R202	F3	R217	F4	R234	H3	U2	C2	U17	D3
C2	E5	C208	H4	R203	F3	R218	H3	R235	H2	U3	A2	U18	D4
C3	A4	C209	G3	R204	F3	R219	G3	R236	H2	U4	A2	U19	E4
C4	D2	C300	C2	R205	F3	R220	G3	R237	G4	U5	A3	U20	E3
C5	E2	CR201	F4	R206	G2	R221	H3	R238	G4	U6	C3	U21	F2
C6	C4	CR202	F4	R207	F2	R222	H3	R239	G3	U7	C4	U101	B5
C7	B1	MP1	A1	R208	G2	R223	H3	R240	G3	U8	B3	U102	A5
C201	E5	Q201	F4	R209	F4	R224	H3	R241	G2	U9	C4	U103	A5
C202	G4	Q202	G4	R210	F4	R225	H3	R242	H4	U10	B2	U104	A4
C203	F4	Q203	F4	R211	F4	R226	H3	R243	G-4	U11	C2	U105	B4
C204	F4	Q204	H3	R212	F2	R227	G2	R244	G4	U12	D3	U106	A4
C205	F3	Q205	G4	R213	F3	R230	H2	R245	D4	U13	D2	U201	F2
C206	F4	Q206	H4	R214	F3	R231	H2	R246	D4	U14	D4	U202	H3
		R1	C2	R215	G3	R232	H2	R304	C2	U15	C3	U203	H2
		R201	F3	R216	F4	R233	H2	U1	A2	U16	D2	U204	G4
												VR201	G4
												VR202	F3
												VR203	F3
												VR204	G3
												VR205	H4
												TP1	H2
												TP2	H2
												TP3	I2
												TP4	D5

FREQUENCY DIVIDER

A10 BD AY LF GENERATOR 08165-66510

STEP GENERATOR

D/A CONVERTER

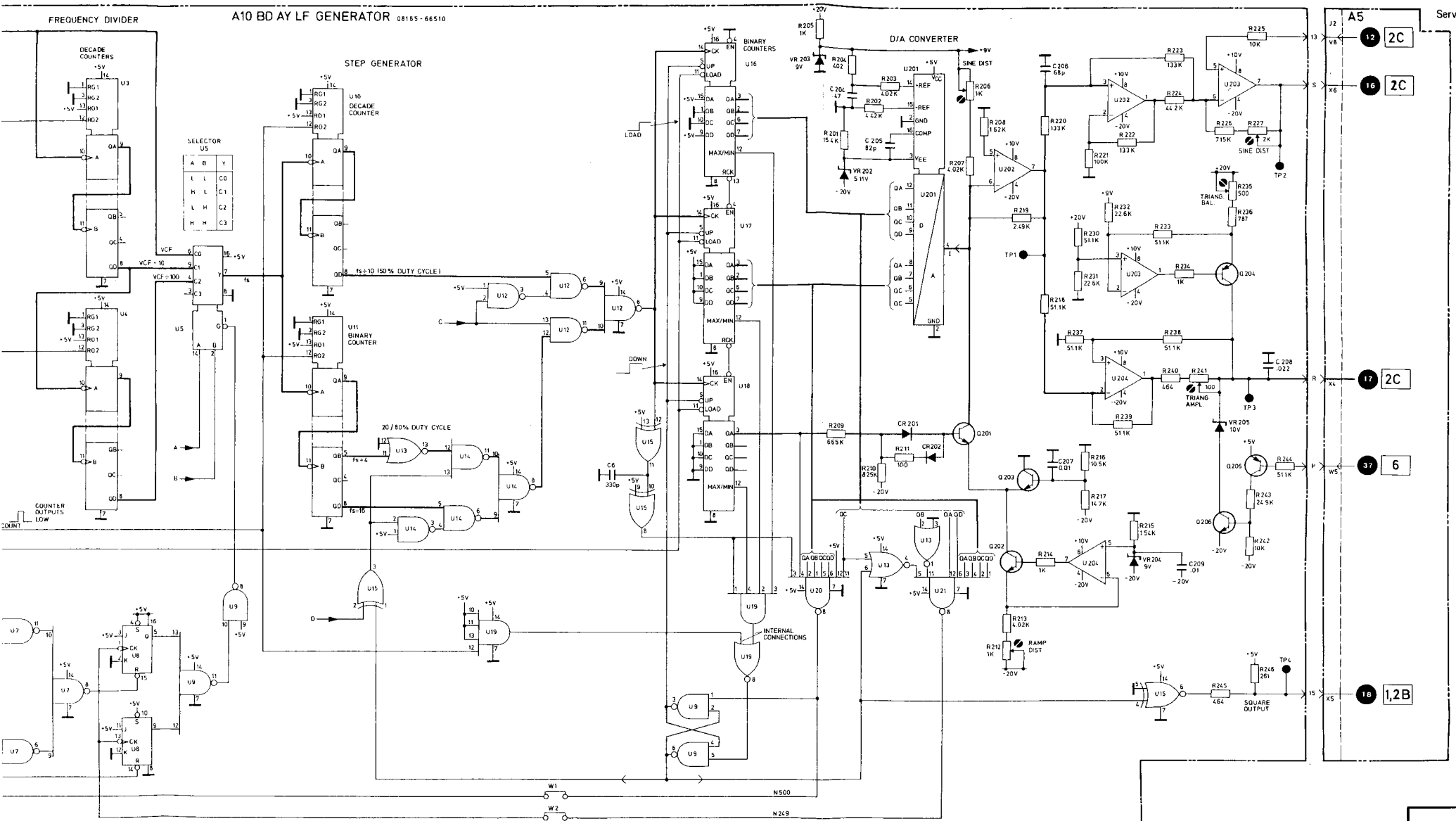

A10 LF GENERATOR

3

A5
2B
10

FREQUENCY DIVIDER

A10 BD AY LF GENERATOR 08165-66510

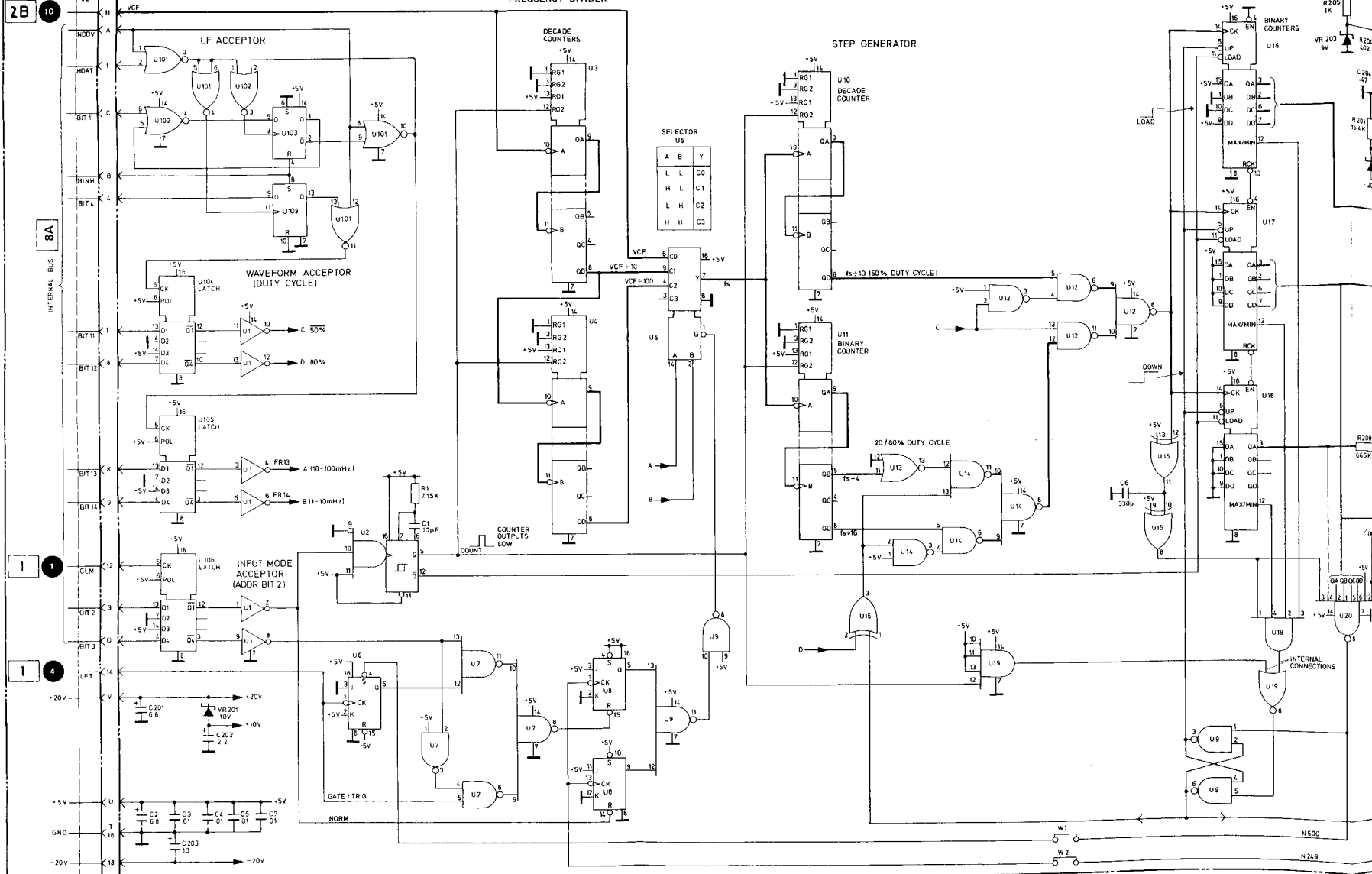

INTERNAL BUS
8A

1

1

W1
W2
N500
N249

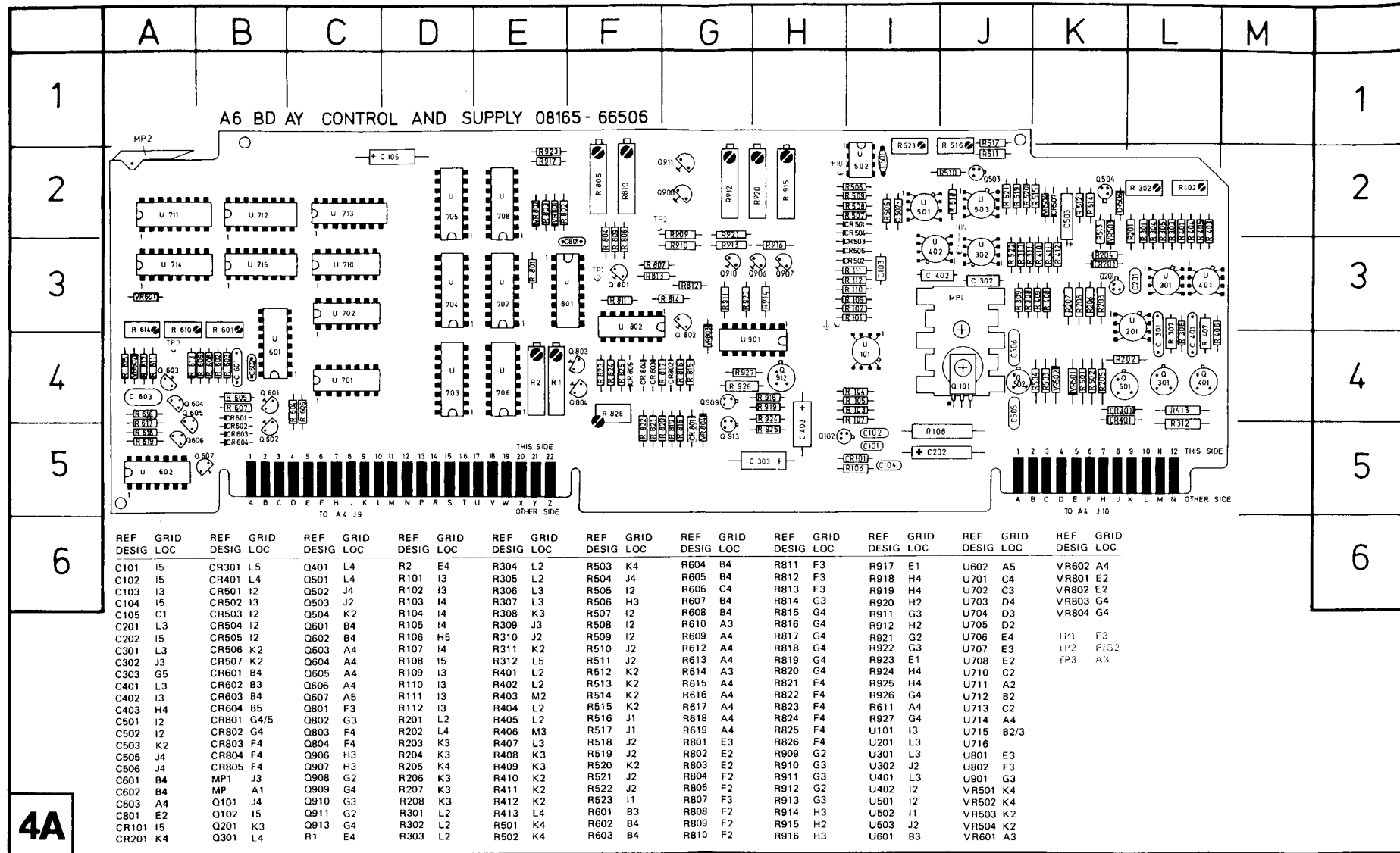

F	G	H	I	J
P/O A4 BD AY OUTPUT AMPLIFIER 08165-66504				

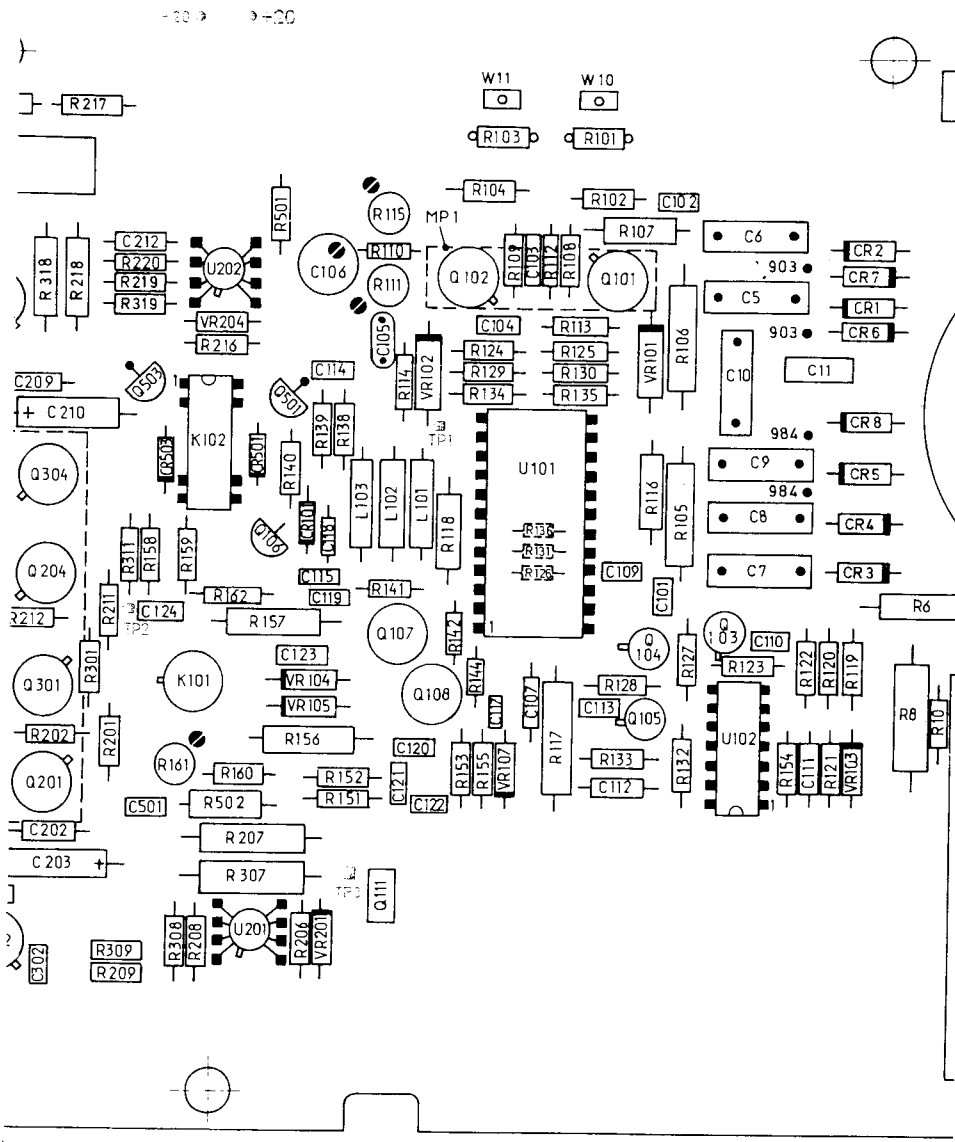

SERVICE BLOCK 4 OUTPUT AMPLIFIER A4

4A

4B

4C

THEORY OF OPERATION

A block diagram of the output amplifier is given in Figure 8-4-1. From the diagram it can be seen that the amplifier comprises four main functional sections:

- active vernier
- power amplifier
- attenuator
- offset generator

Each of these blocks is described in detail in the following paragraphs.

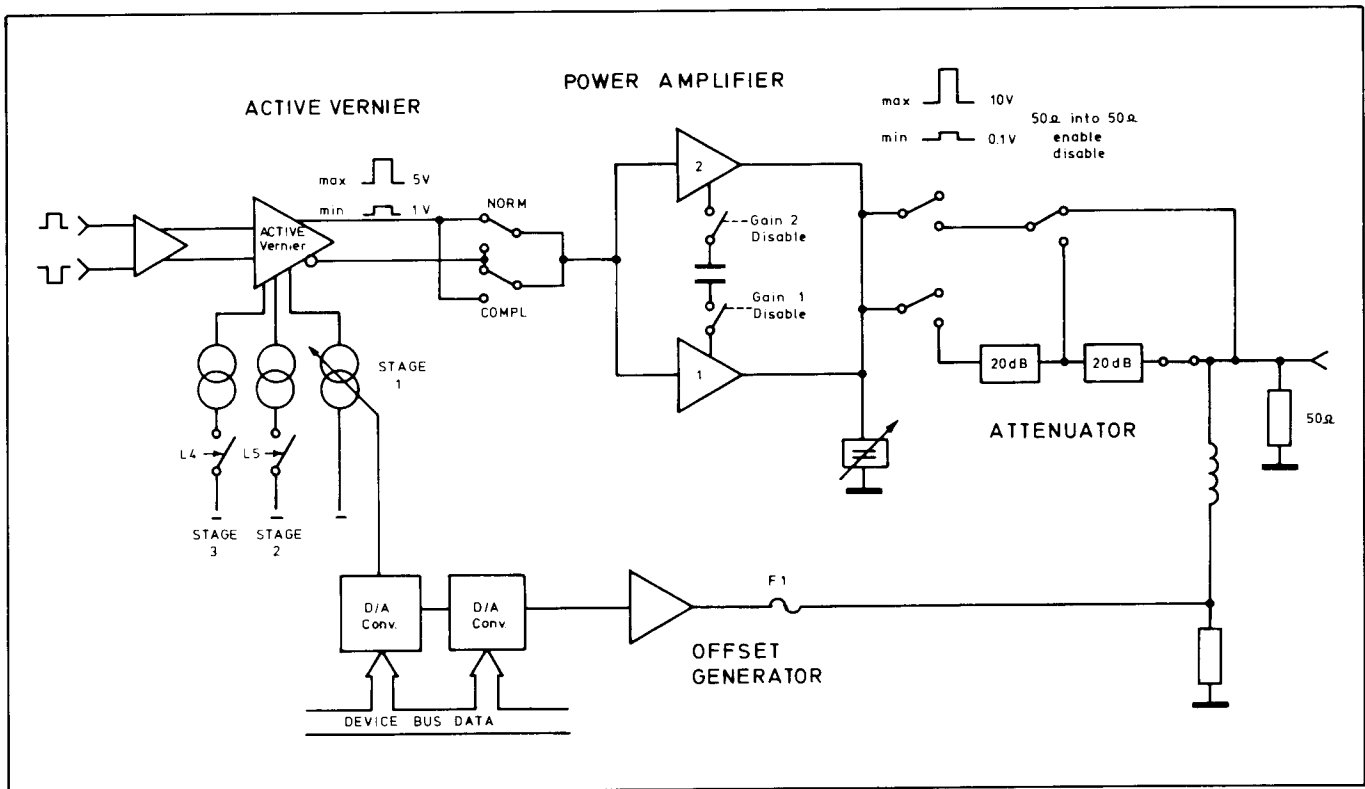

Figure 8-4-1. Output amplifier block diagram

Active Vernier (Service Sheet 4A)

The active vernier comprises 3 attenuator stages in parallel, each stage consisting of two attenuating elements, one for normal and one for complement output. As Figure 8-4-2 shows, each attenuating stage is a differential amplifier connected so that the signal current flows into (or out of) the common emitters. The output current is taken from one of the collectors and then converted to voltage.

In a differential amplifier, the current flowing in each collector is proportional to the potential difference between the two bases. Thus by varying V_V (see Figure 8-4-2) on the base of one of the transistors, the current I_{OUT} can be controlled. However, because of the characteristic of the base-emitter voltage of each transistor, the attenuation has a logarithmic characteristic.

The input signal controls the share of current source I which flows through each input transistor. Similarly, V_v controls the current in both attenuator transistors $Q1, Q2$ or $Q3, Q4$ (Figure 8-4-2). Suppose that V_v sets an attenuation factor of 2 and, for simplicity, $I = 1$ mA. If the input is such that I is shared equally, then $I_1 = 0.5$ mA and $I - I_1 = 0.5$ mA. Also $I_x = 1/2 I_1 = 0.25$ mA, and $I_y = 1/2 (I - I_1) = 0.25$ mA. Now, suppose that the input changes the sharing of current I so that $I_1 = 0.2$ mA, and $I - I_1 = 0.8$ mA, then $I_y = 0.4$ mA and $I_x = 0.1$ mA. In either case, the sum $I_x + I_y$ remains constant for all input signals and attenuation ratios.

Therefore a constant current source (controlled by the amplitude setting via the microprocessor and D/A converter U801) can be used to supply the current $I_y + I_x$.

$$\text{If } I_x + I_y = I, \text{ then } I_{OUT} = \overline{I_{OUT}} = 0$$

$$\text{If } I_x + I_y = 0, \text{ then } I_{OUT} = \overline{I_{OUT}} = 0.5 I$$

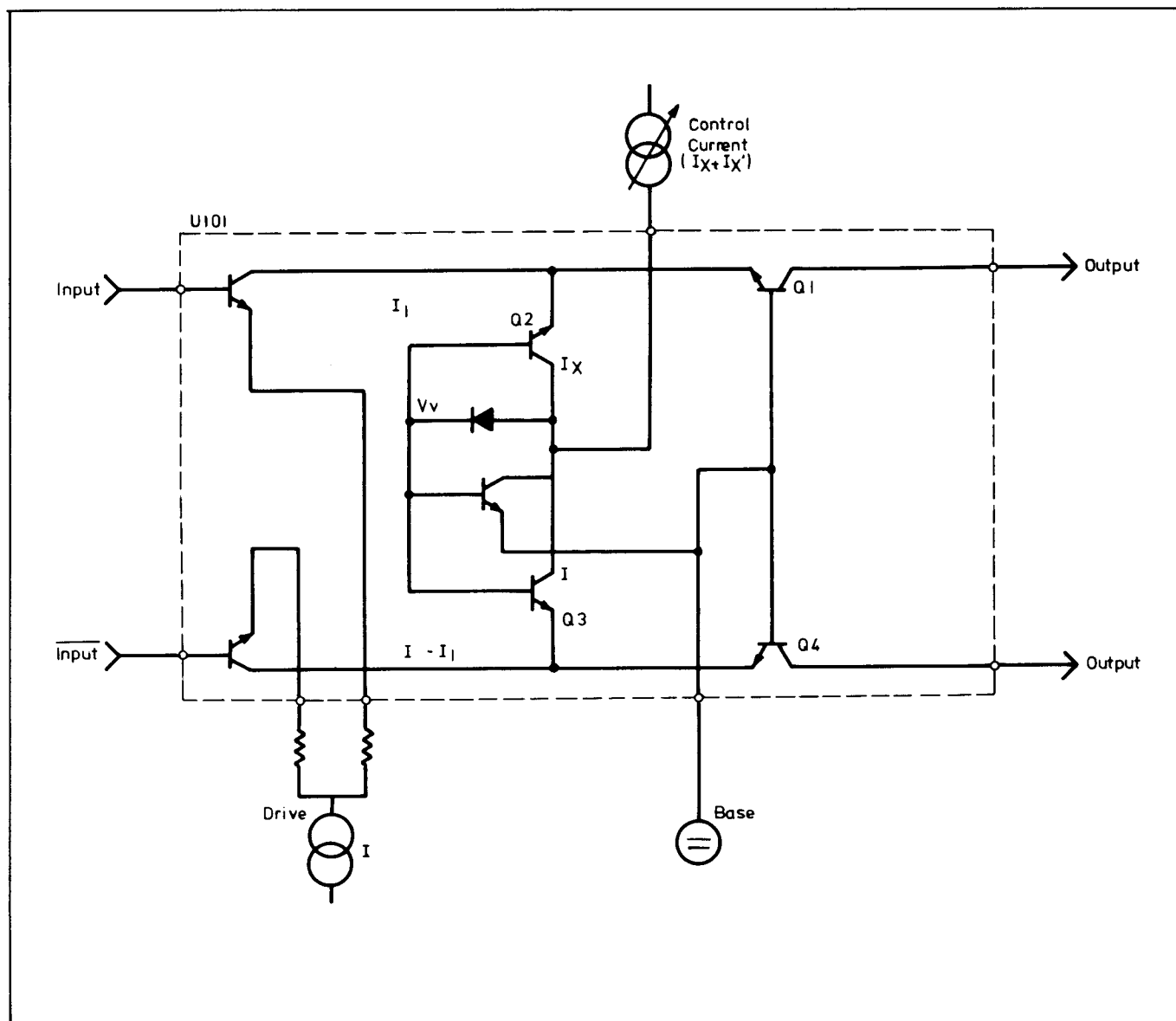

Figure 8-4-2. Operating principle for each stage of active vernier

Current sources: The current I (see Figure 8–4–3) for each attenuator stage is provided by current sources comprising U102, Q103, Q104 and Q105.

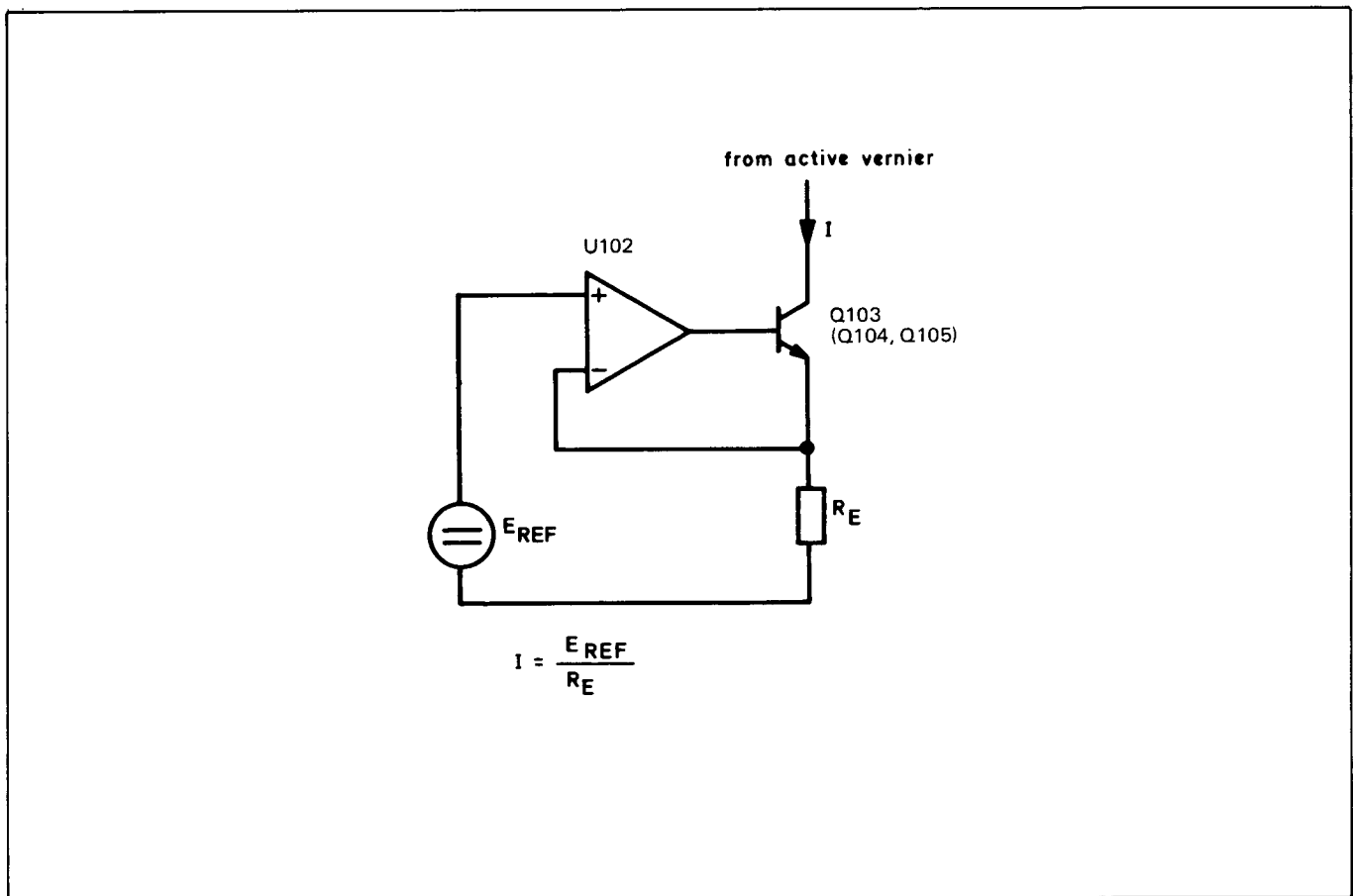

Figure 8–4–3. Functional diagram of active vernier current source

Control current sources: Each attenuator stage of the vernier IC has its own control current source (U802–Q801, U901–Q906 and linearity correction U802–Q803, Q804 for 1st stage, U901–Q907 for 2nd stage, U901–Q910 for 3rd stage) to calibrate the required attenuation of the stage.

Stages 2 and 3 also have transistor switches to enable cut-off of the corresponding stage, Microprocessor-derived signal L4 switches stage 3 on and off; L5 switches stage 2 on and off.

Figure 8–4–4 illustrates the interstage relationship of the active vernier for the 8165A output versus programmed value and for the vernier output versus programmed value.

As can be seen from Figure 8–4–4, stage 1 acts as the variable part of the vernier attenuator, and the maximum output from the total vernier is 5 V. With stage 2, the signal is attenuated to 50 % of maximum amplitude, and stage 3 attenuates the output signal a further 20 %. Stage 1 (variable part) also provides 20 % attenuation with 8-bit resolution.

Control current source for stage 1 consists of one current source driven by the D/A converter U801, to calibrate the lower attenuation point, and another current source to calibrate the upper attenuation point.

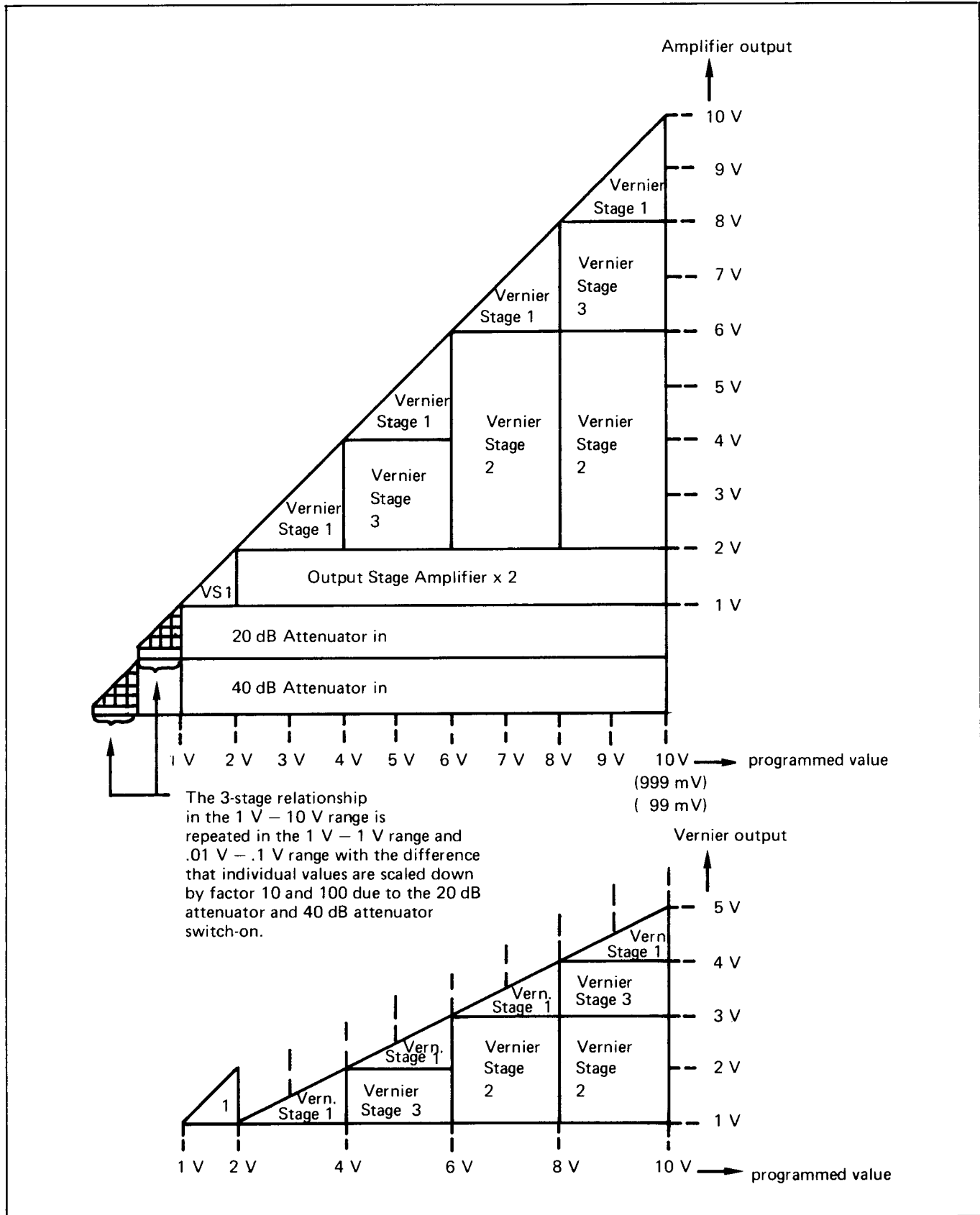

Figure 8-4-4. Inter-relationship of active vernier stages

Power Amplifier (Service Sheet 4B)

A block diagram of the power amplifier section is given in Figure 8-4-5, in which it can be seen that the power amplifier comprises two amplifiers connected in parallel.

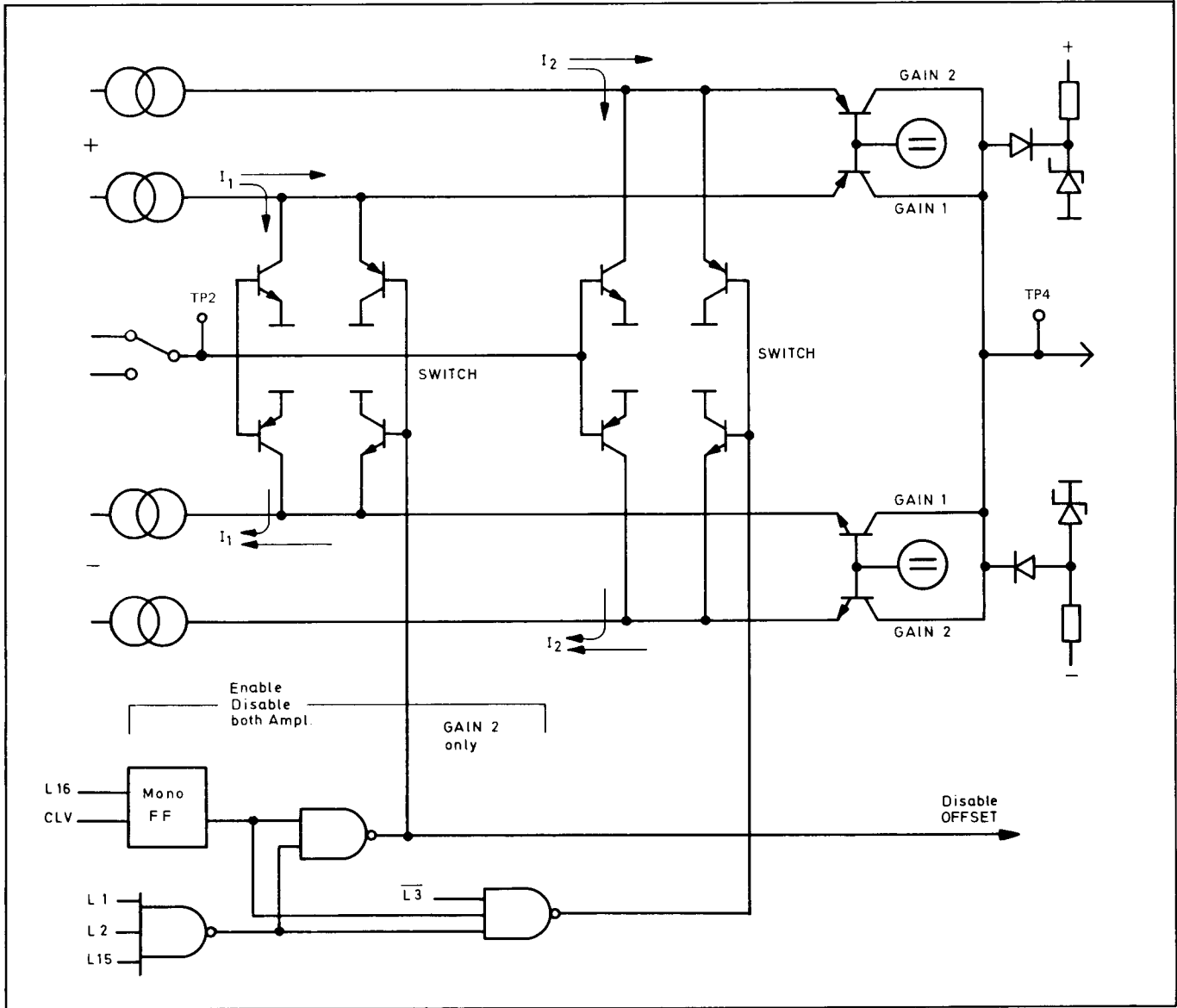

Figure 8-4-5. Power amplifier block diagram

In normal operation, the Gain 2 amplifier is switched on and off via signal $\overline{L3}$ at NAND gate U502. When switched off, total amplification (input to output) is unity, while switching on provides a total gain factor of 2 (Note: with a change in amplitude setting, both amplifiers are switched off momentarily (~ 5 ms) by the action of monoflop U503. A change in L1, L2, L14 or L15 causes L16 at U502/Pin 4 to go high, so that the next CLV clock pulse triggers the monoflop and the amplifiers are disabled).

Figure 8-4-6 illustrates the operating principle of the switchable amplifier, the only difference in normal operation between this and the 'Gain 1' amplifier being the switch function. The amplifier consists of 2 complementary

cascode stages working in push-pull mode (complementary cascode = NPN and PNP transistor connected in common emitter/common base configuration to provide high input impedance, high output impedance and high gain).

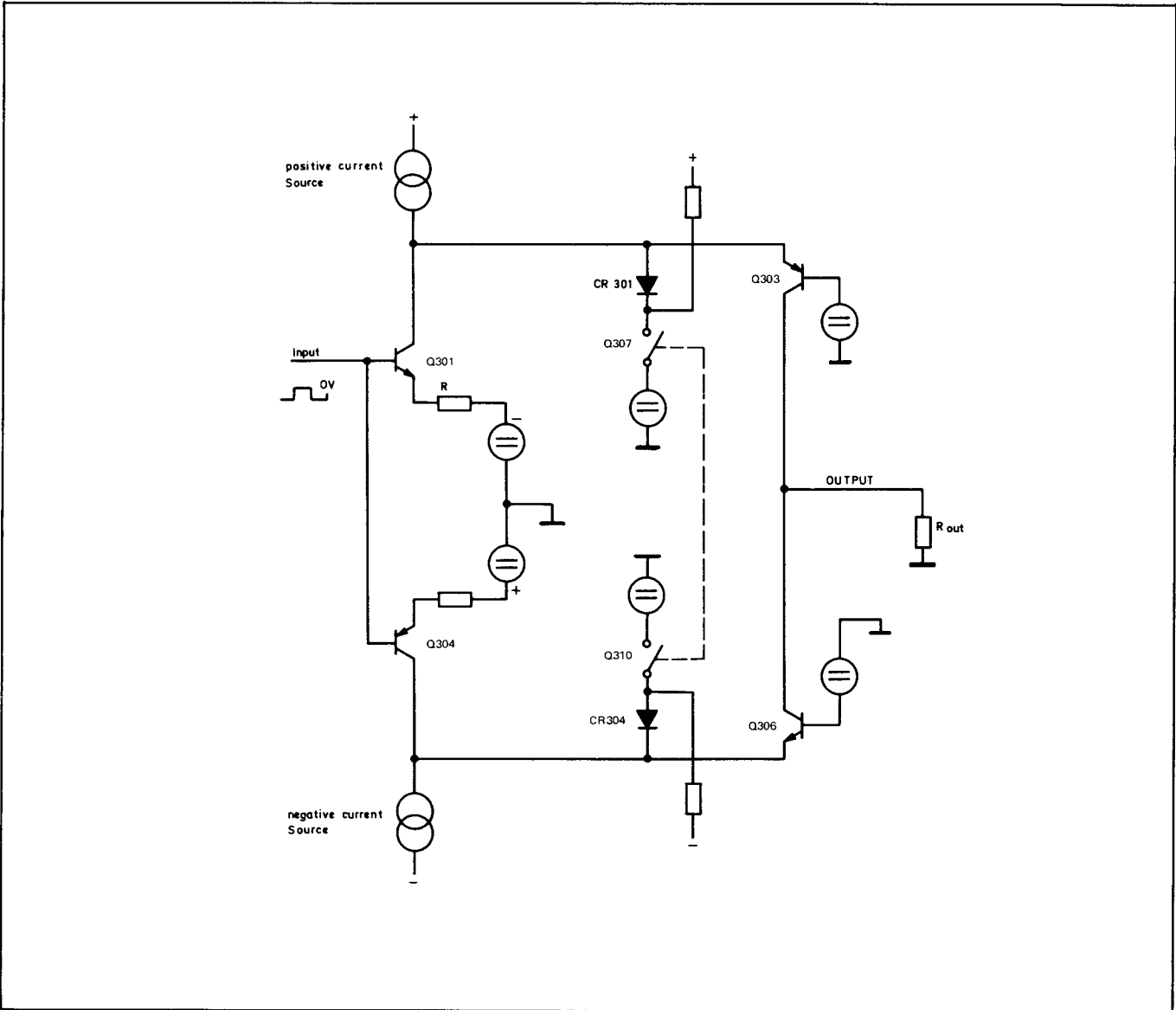

Figure 8-4-6. Switchable amplifier functional diagram

The positive cascode stage comprises common emitter transistor Q301, common base transistor Q303 and the positive current source; the negative cascode stage comprises common emitter transistor Q304, common base transistor Q306 and negative current source. Q301 and Q304 operate as voltage-controlled current sources, the input voltage to their bases determining which is more heavily biased (the minimum bias current flows continually through all 4 transistors due to it being a linear amplifier).

To switch the amplifier off, transistor switches Q307 and Q310 are switched on, so that all current flows through diodes CR301, CR304 into the voltage sources.

Attenuator (Service Sheet 4B)

Two 20 dB resistive attenuators are located between the power amplifier and the output BNC connector. The first 20 dB attenuator is switched in by the action of relays K401, K404 and K405 i.e. in 8165A amplitude range 100 mV – 999 mV. The second 20 dB is switched in (to make a total 40 dB) by K402 i.e. in 8165A amplitude range 10 mV – 99 mV.

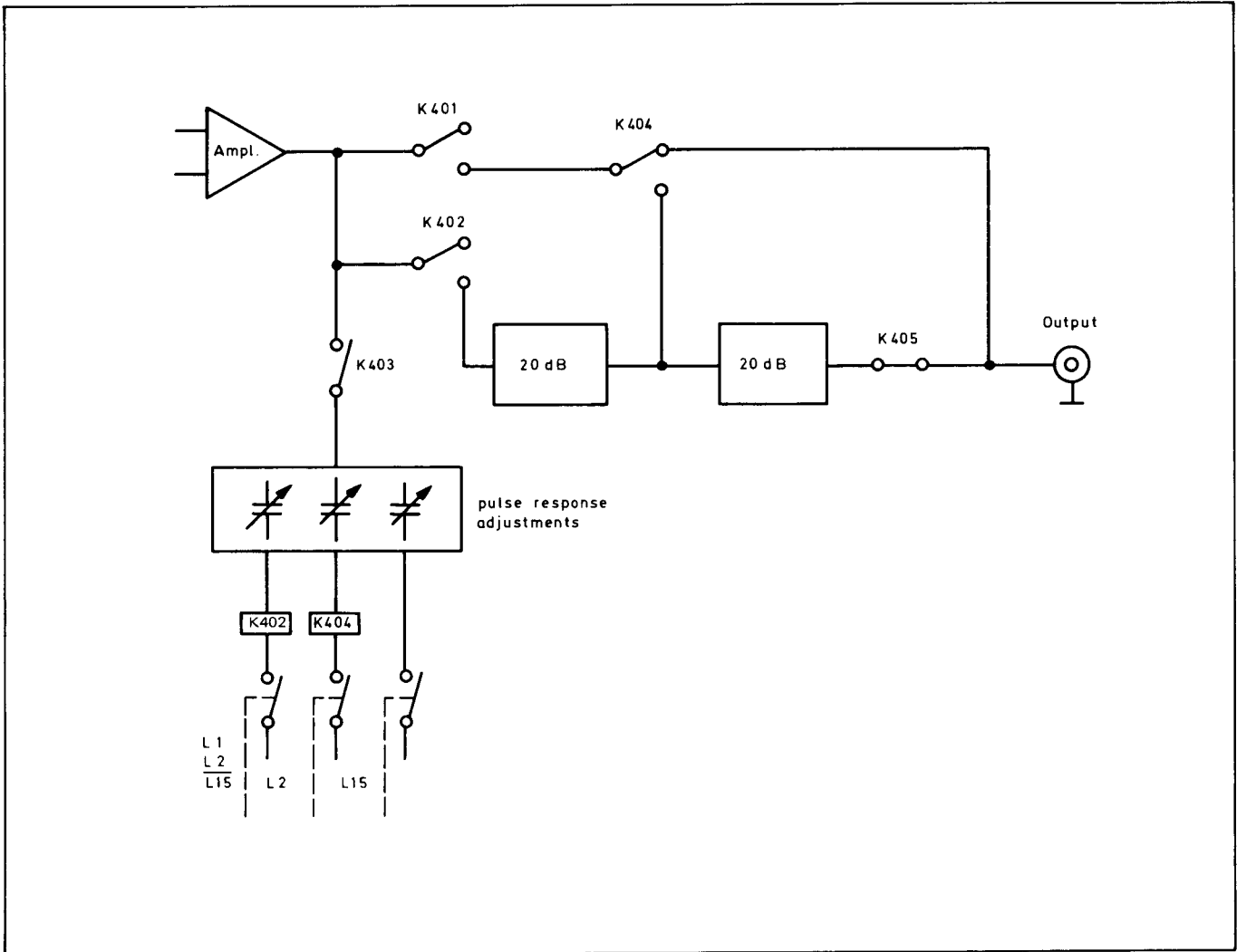

Figure 8-4-7. Attenuator ranges

Offset Generator (Service Sheet 4C)

A block diagram of the offset generator is given in Figure 8-4-8. Depending on the desired output offset, the microprocessor transmits the necessary digital information to the 10-bit D/A converter, which in turn controls a positive and negative current source.

To keep capacitive loading to a minimum at the 8165A output, a filter (L1, R35, C9, R37) decouples the offset generator from the output amplifier.

During a change in the 8165A's output amplitude, the offset generator is momentarily (~ 5 ms) switched off via signal 24 at NOR gate U1, pin 12 and pin 6. When this signal is high, transistors Q3 and Q9 are switched on thus disabling both current sources.

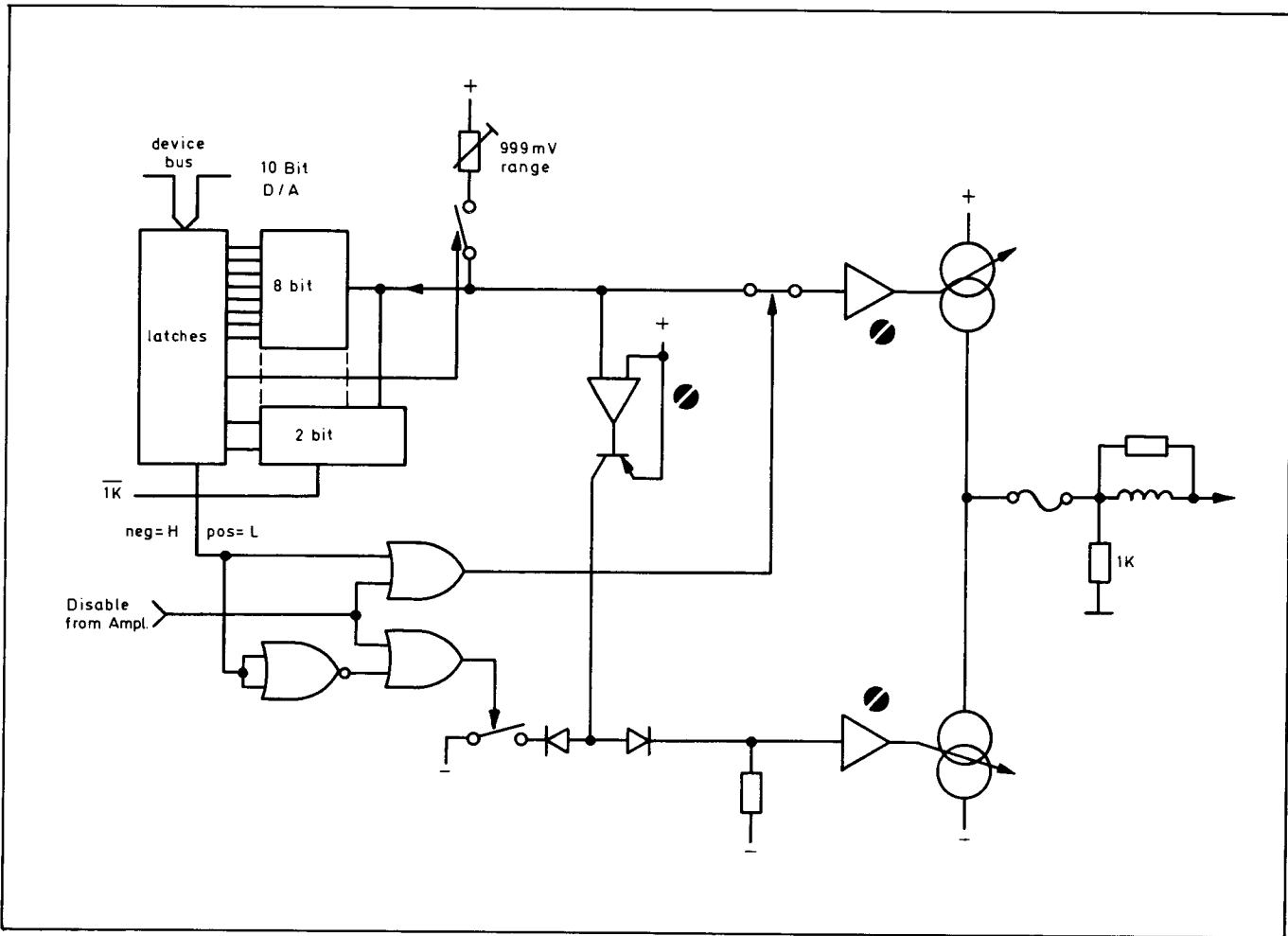

Figure 8-4-8. Offset generator block diagram

TROUBLESHOOTING

Active Vernier

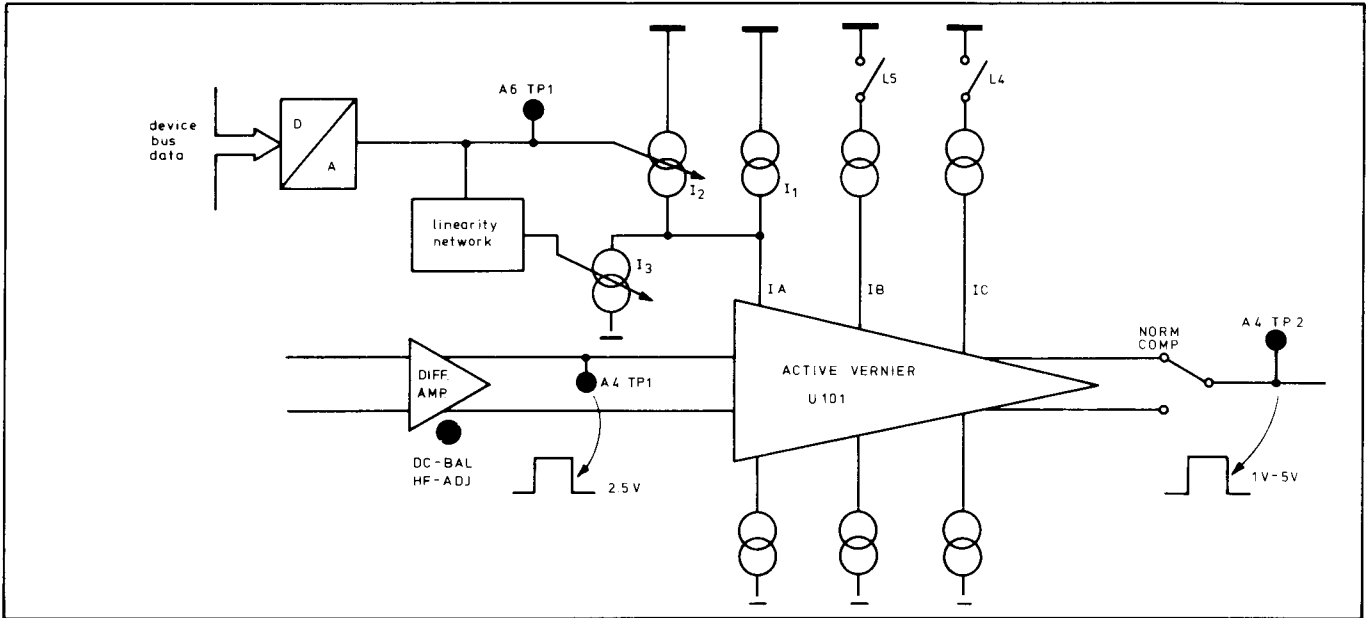

Figure 8-4-9. Active Vernier

Table 8-4-1. D/A converter voltage to current table

Amplitude Display (50 Ω)	D/A conv.								Current I_A	Control voltage A6 TP1	Correction Q802/C	Vernier Amplitude A4 TP2
	L13	L12	L11	L10	L9	L8	L7	L6				
1.00 V (100 mV, 10 mV)	1	1	0	0	0	1	1	0	≈ 40 mA	-4.0 V	-0.17 V	≈ 1.00 V
1.10 V		1	0	1	1	0	0	1	36 mA	-3.6 V	-0.58 V	1.10 V
1.20 V		1	0	0	1	1	1	0	32 mA	-3.2 V	-0.95 V	1.20 V
1.34 V		1	0	0	0	0	0	1	27 mA	-2.7 V	-1.27 V	1.34 V
1.35 V		1	0	0	0	0	0	0	26 mA	-2.6 V	-1.28 V	1.35 V
1.98 V		0	0	0	0	0	0	1	6.4 mA	-50 mV	-50 mV	1.98 V
1.99 V (190 mV, 19 mV)		0	0	0	0	0	0	0	≈ 6.1 mA	0 V	0 V	1.99 V

Table 8-4-2. Complete current range table

Amplitude Display (50 Ω)	Vernier Amplitude A4 TP2	Current sources			Control signals		
		I_A 6 mA - 40 mA	I_B 70 mA	I_C 42 mA	L3 (Gain 2)	L4	L5
1 V - 1.99 V	≈ 1 V - 1.99 V	active	on	on	0	1	1
2 V - 3.99 V	1 V - 1.99 V	active	on	on	1	1	1
4 V - 5.99 V	2 V - 2.99 V	active	on	off	1	0	1
6 V - 7.99 V	3 V - 3.99 V	active	off	on	1	1	0
8 V - 9.99 V	4 V - 4.99 V	active	off	off	1	0	0

Power Amplifier

Table 8-4-3. Amplitude ranges p-p (1 kΩ/50 Ω)

DISPLAY (AMPLITUDE)	TP2	TP4	GAIN1 (Q201-Q206)	GAIN2 (Q301-Q306)	$\overline{L3}$
2.00 V	≈ 1 V p-p	2.0 V	on	off	0
3.99 V	≈ 2 V p-p	3.99 V	on	off	0
4.00 V	≈ 1 V p-p	4.00 V	on	on	1
8.00 V	≈ 2 V p-p	8.00 V	on	on	1
10.0 V	≈ 2.5 V p-p	10.0 V	on	on	1
12.0 V	≈ 3 V p-p	12.0 V	on	on	1
16.0 V	≈ 4 V p-p	16.0 V	on	on	1
18.0 V	≈ 4.5 V	18.0 V	on	on	1
20.0 V	≈ 5 V	20.0 V	on	on	1

Table 8-4-4. Amplitude ranges p-p (50 Ω / 50 Ω)

DISPLAY (AMPLITUDE)	TP2	TP4	GAIN1 (Q201 - Q206)	GAIN2 (Q301 - Q306)	$\overline{L3}$
10 mV or 100 mV or 1.00 V	≈ 1V p-p	1 V p-p	on	off	0
20 mV or 200 mV or 2.00 V	≈ 1 V p-p	2 V p-p	on	on	1
40 mV or 400 mV or 4.00 V	≈ 2 V p-p	4 V p-p	on	on	1
60 mV or 600 mV or 6.00 V	≈ 3 V p-p	6 V p-p	on	on	1
80 mV or 800 mV or 8.00 V	≈ 4 V p-p	8 V p-p	on	on	1
99 mV or 999 mV or 10.0 V	≈ 5 V p-p	10 V p-p	on	on	1

Table 8-4-5. Attenuator ranges

Amplitude	Attenua.	Imp.	L			K					
			L1	L2	L15	K102	K401	K402	K403	K404	K405
—	Disable	50Ω	1	1	0	on	—	—	on	—	on
2V - 20V	0 dB	1KΩ	0	1	1	—	on	—	—	—	—
1V - 10V	0 dB	50Ω	0	1	0	on	on	—	on	—	on
100 mV - 999 mV	20 dB	50Ω	0	0	1	on	on	—	on	on	on
10 mV - 99 mV	40 dB	50Ω	1	1	1	on	—	on	on	—	on

Table 8-4-6. Norm-Inverting

Phase	L ₁₄
NORM	0
INV	1

Enable – Disable

While $\overline{L3}$ enables/disables gain 2 only, gain 1 and gain 2 can be disabled under certain conditions. A change of L1.L2. L14. L15 will cause L16 to go high (via μP) so with the next CLV the Mono FF will disable both stages and the offset generator for about 5 ms. This occurs in the following events:

- transition from 50 Ω to 1 k Ω source impedance, or NORM to COMP
- amplitude change from 99 mV to 100 mV
- amplitude change from 999 mV to 1.00 V
- offset change from 999 mV to 1.00 V

Offset Generator

Table 8-4-7. D/A converter voltage table (50 Ω / 50 Ω)

OFFSET DISPLAY	U715 pin				U714 pin						TP3 (if pos. selected)	TP5 (if neg. selected)
	12	4	15	2	10	6	12	4	15	2		
0 mV	0	0	0	0	0	0	0	0	0	0	16.90 V	-17.79 V
10 mV	0	0	0	0	0	0	1	0	1	0	16.89 V	-17.78 V
100 mV	0	0	0	1	1	0	0	1	0	0	16.82 V	-17.71 V
500 mV	0	1	1	1	1	1	0	1	0	0	16.55 V	-17.43 V
999 mV	1	1	1	1	1	0	0	1	1	1	16.23 V	-17.10 V
1.00 V	0	0	0	1	1	0	0	1	0	0	16.24 V	-17.09 V
2.00 V	0	0	1	1	0	0	1	0	0	0	15.61 V	-16.42 V
3.00 V	0	1	0	0	1	0	1	1	0	0	14.99 V	-15.75 V
4.00 V	0	1	1	0	0	1	0	0	0	0	14.37 V	-15.07 V
5.00 V	0	1	1	1	1	1	0	1	0	0	13.75 V	-14.40 V

Table 8-4-8. D/A converter table (1 k Ω / 50 Ω)

OFFSET DISPLAY	U715 pin				U714 pin						TP3 (if pos. selected)	TP5 (if neg. selected)
	12	4	15	2	10	6	12	4	15	2		
6.00 V	1	0	0	1	0	1	1	0	0	0	14.92 V	-15.66 V
7.00 V	1	0	1	0	1	1	1	1	0	0	14.81 V	-15.31 V
8.00 V	1	1	0	0	1	0	0	0	0	0	14.29 V	-14.95 V
9.00 V	1	1	1	0	0	0	0	1	0	0	13.96 V	-14.59 V
10.00 V	1	1	1	1	1	0	0	1	1	1	13.63 V	-14.23 V

Table 8-4-9. Offset polarity and range

U715 pin	offset		range	
	pos	neg	0-999 mV	1 V - 5 V
6	1	0		
10			0	1

Offset disable

As with the power amplifier, the offset is disabled for 5 ms under the following conditions:

- transition from 50 Ω to 1 k Ω source impedance, or NORM to COMP
- amplitude change from 99 mV to 100 mV
- amplitude change from 999 mV to 1.00 V
- offset change from 999 mV to 1.00 V

TROL AND SUPPLY 08165-66506

ACCEPTOR

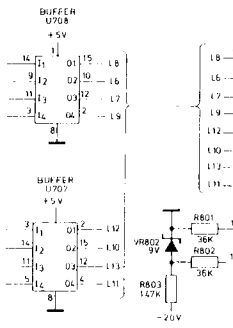
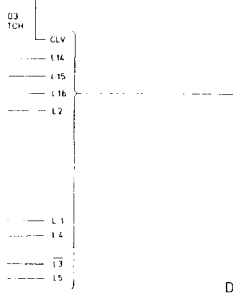
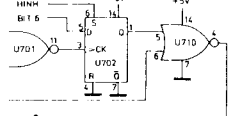

AMPLIFIER 08165-66504

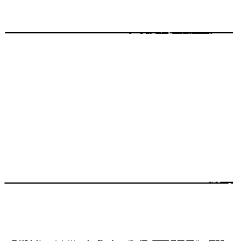

D/A CONVERTER

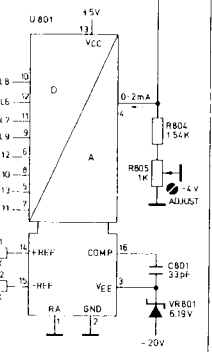

AMPLIFIER

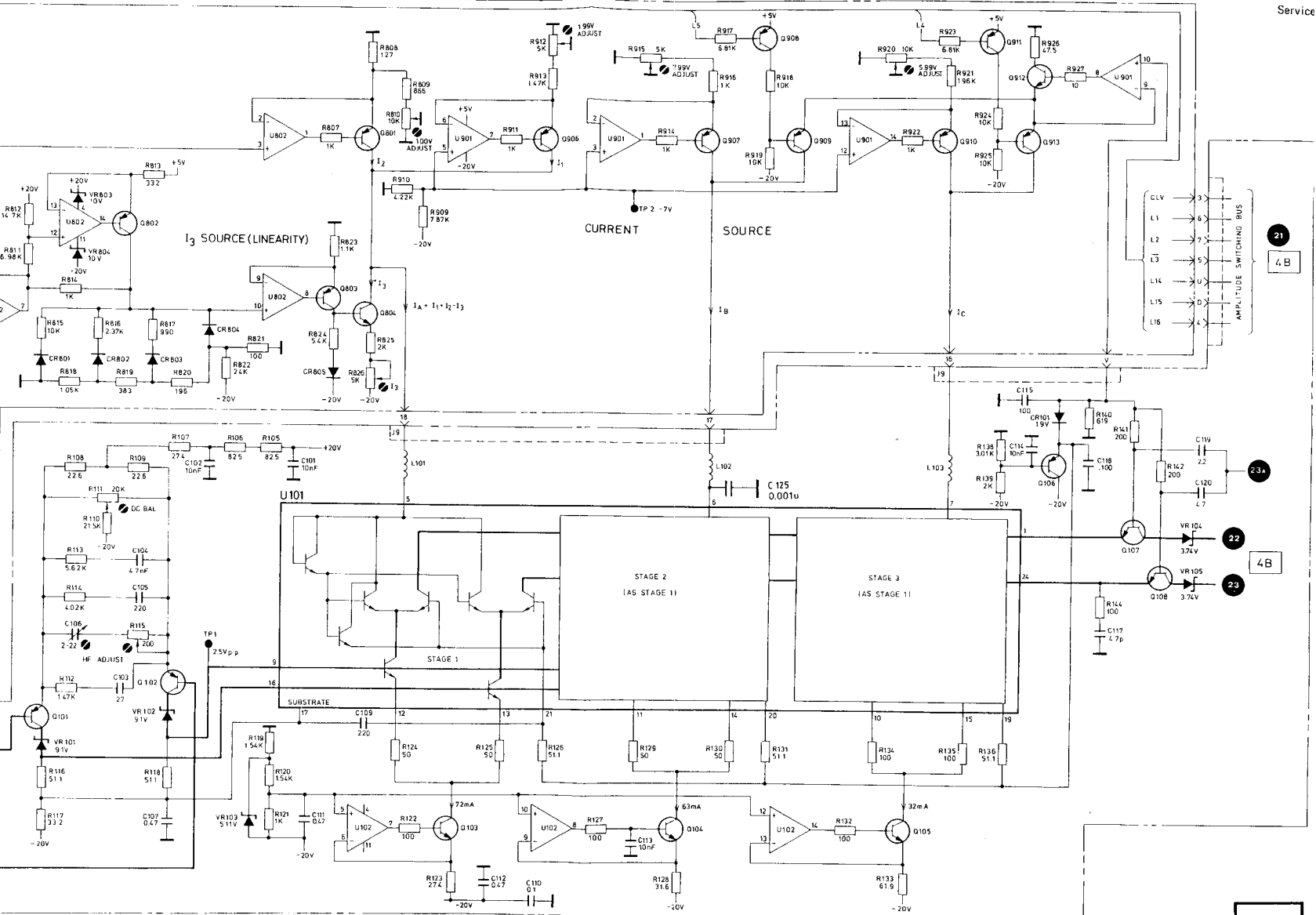
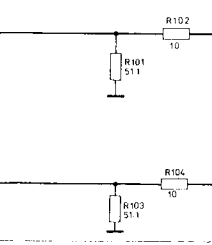

A6, A4 AMPLITUDE VERNIER

4A

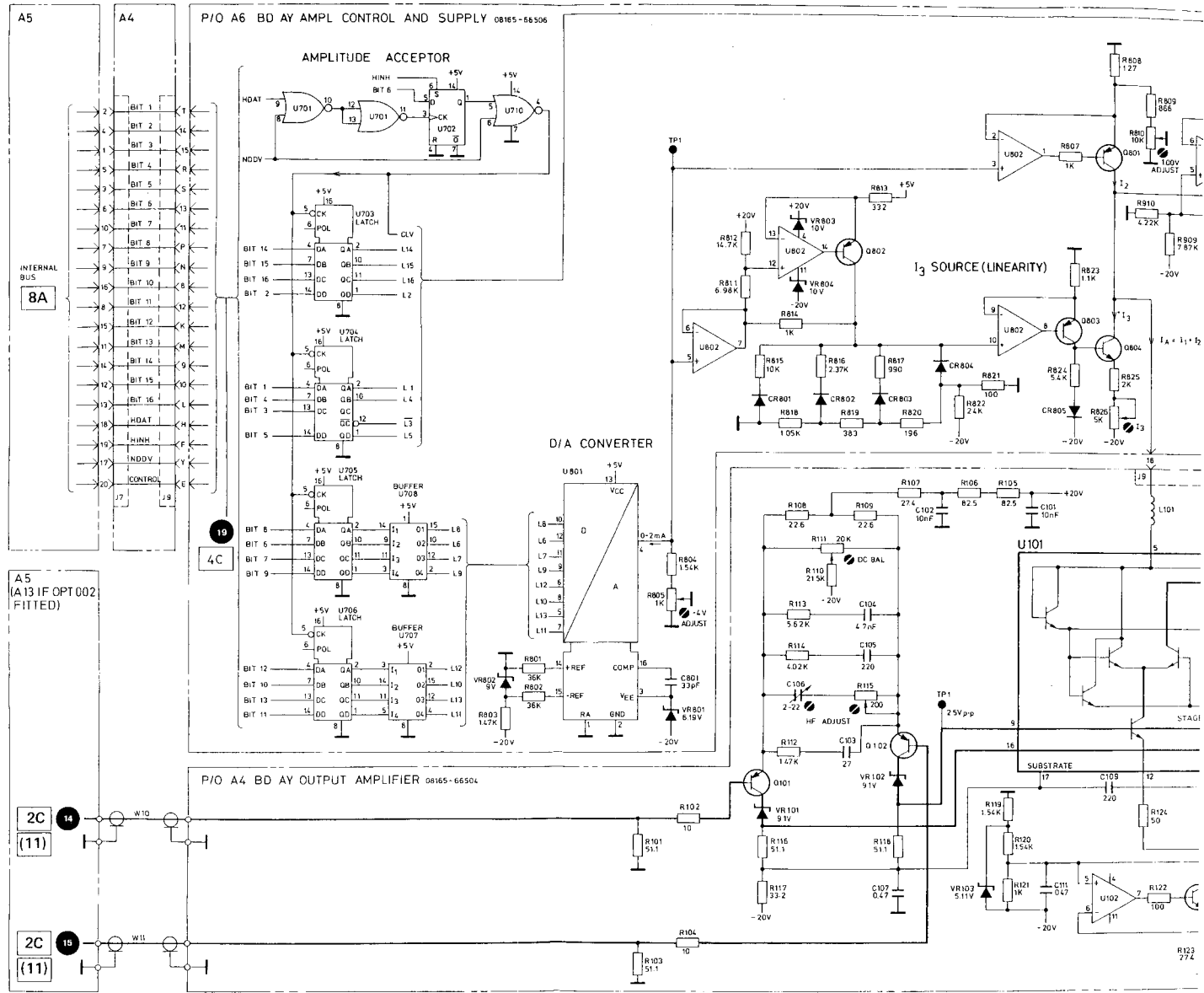

D E F G H I J K L M

8165-66504

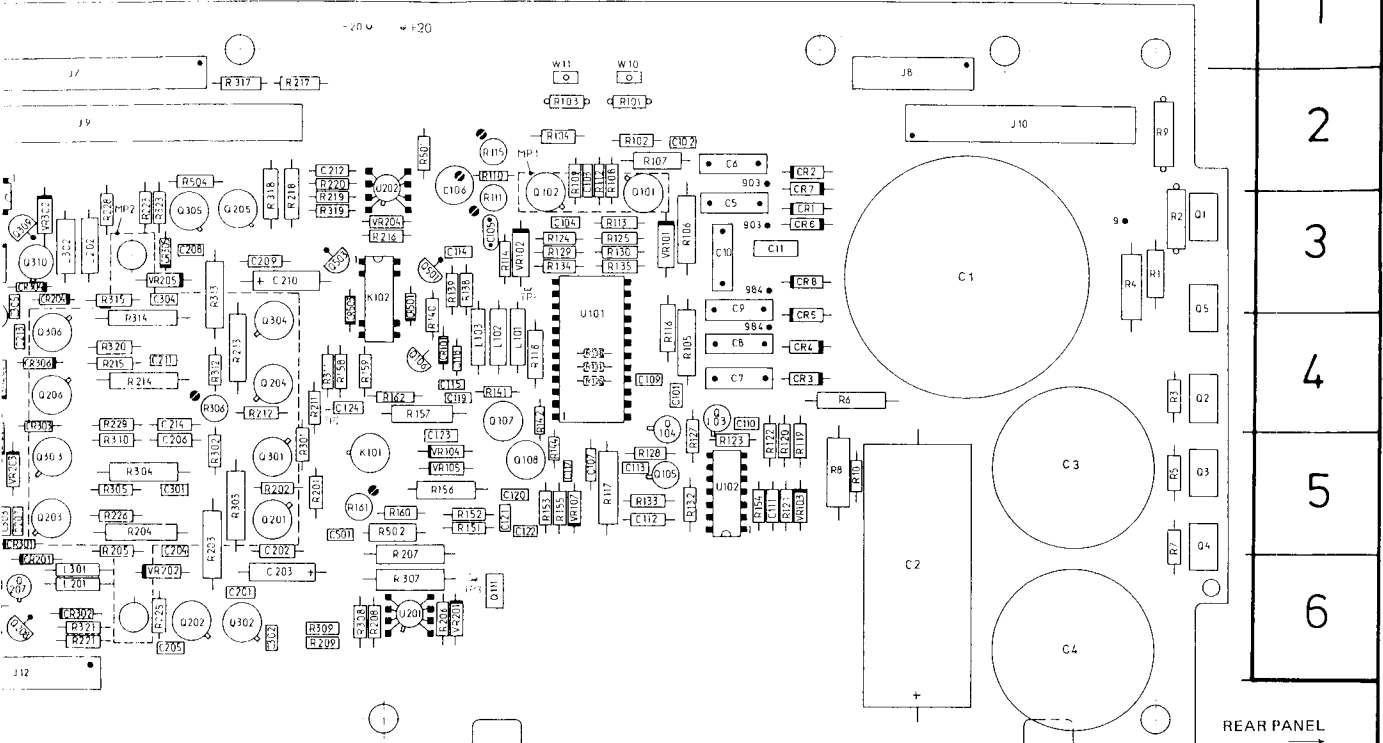

REF DESIG	GRID LOC	REF DESIG	GRID LOC	REF DESIG	GRID LOC	REF DESIG	GRID LOC	REF DESIG	GRID LOC	REF DESIG	GRID LOC	REF DESIG	GRID LOC	REF DESIG	GRID LOC
C206	E4	C304	E3	C514	A3	CR206	C4	CR505	B4	K404	B5	Q1	M2	Q108	H5
C207	C5	C305	C3	CR1	J3	CR301	C5	CR506	C5	K405	B6	Q2	M4	Q111	G6
C208	E3	C501	F5	CR1	J3	CR302	D6	J7	D1	L101	H3	Q3	M5	Q201	E5
C209	E3	C502	C6	CR2	J2	CR303	D4	J8	K1	L102	G3	Q4	M5	Q202	E6
C210	E3	C503	C6	CR3	J4	CR304	D3	J9	D2	L103	G3	Q5	M3	Q203	D5
C211	E4	C504	A1	CR4	J4	CR305	E3	J10	K2	L201	D6	Q101	I2	Q204	E4
C212	F2	C505	B2	CR5	J4	CR306	D4	J12	D6	L202	D3	Q102	H2	Q205	E2
C213	C4	C506	B3	CR6	J3	K101	F4	L101	F4	Q103	D6	Q103	I4	Q206	D4
C214	E4	C508	B3	CR7	J2	CR501	G3	K102	F3	L302	D3	Q104	I4	Q207	C6
C301	E5	C509	C5	CR8	J3	CR502	C4	K401	C4	MP1	H2	Q105	I5	Q208	C6
C302	F6	C510	E3	CR101	G4	CR503	F3	K402	B4	MP2	D3	Q106	G4	Q209	C6
C303	C5	C511	A3	CR201	D5	CR504	A4	K403	A4	MP3	B5	Q107	G4	Q210	C3
		C512	A3	CR203	C4									Q501	G3
		C513	A3	CR204	D3									Q502	C4
														R1	M3
														R2	M2/3
														R3	M4
														R4	M3
														R5	M5
														R6	J/K4
														R7	M5
														R8	J5
														R9	M2
														R10	J5
														R101	H/I2
														R102	I2
														R103	H2
														R104	H2
														R105	I3
														R106	I3
														R107	I2

REF DESIG	GRID LOC	REF DESIG	GRID LOC	REF DESIG	GRID LOC
R108	H2	R221	D6	U501	C2
R109	H2	R222	C6	U502	B2
R110	G2	R223	E2	U503	B1
R111	G2	R225	E6	VR101	I3
R112	H2	R226	D5	VR102	H3
R113	H3	R227	C5	VR103	J5
R114	G3	R228	D2	VR104	G5
R115	G2	R229	D5	VR105	G5
R116	I3	R230	C3	VR107	H5
R117	H5	R301	F4	VR201	G6
R118	H4	R302	E4	VR202	E6
R119	J4	R303	E5	VR203	C5
R120	J4	R304	D5	VR204	F3
R121	J5	R305	D5	VR205	E3
R122	J4	R306	E4	VR206	C4
R123	I4	R307	G6	VR207	C5
R124	H3	R308	F6	VR208	C3
R125	H3	R309	F6	VR301	C5
R126	H4	R310	D4	VR302	D3
R127	I4	R311	F4	W10	H2
R128	I5	R312	E4	W11	H2
R129	H3	R313	E3	TP1	H3
R130	H3	R314	D3	TP2	F4
R131	H4	R315	D3	TP3	G6
R132	I5	R317	E2	TP4	C4
R133	I5	R318	E2		
R133	I5	R319	F3		
R134	H3	R320	D4		
R135	H3	R321	D6		
R136	H4	R322	C4		
R138	G3	R323	E2		
R139	G3	R401	B5		
R140	G3	R402	A5		
R141	G4	R403	A4		
R142	H4	R404	B4		
R143	H5	R405	B5		
R144	H4	R406	A5		
R151	G5	R407	A5		
R152	G5	R408	A6		
R153	H5	R409	A6		
R154	J5	R410	B6		
R155	H5	R501	G2		
R156	G5	R502	F5		
R157	G4	R503	C3		
R158	F4	R504	E2		
R159	F4	R506	A4		
R160	G5	R507	C6		
R161	F5	R508	C6		
R162	F4	R510	C3		
R201	F5	R511	B3		
R202	F5	R512	B3		
R203	E5	R513	B1		
R204	D5	R514	B2		
R205	D5	R515	C5		
R206	G6	R516	A5		
R207	G5	R517	C3		
R208	F6	R520	C3		
R209	F6	R521	B3		
R211	F4	R522	B3		
R212	E/F4	R523	B3		
R213	E4	R524	A4		
R214	D/E4	R525	A3		
R215	D4	R526	A3		
R216	F/G3	U101	H3		
R217	F2	U102	H2		
R218	F2	U201	G6		
R219	F2	U202	F2		
R220					

A

B

C

D

E

F

G

H

A4 BD AY OUTPUT AMPLIFIER 08165-66504

-20 3 +20

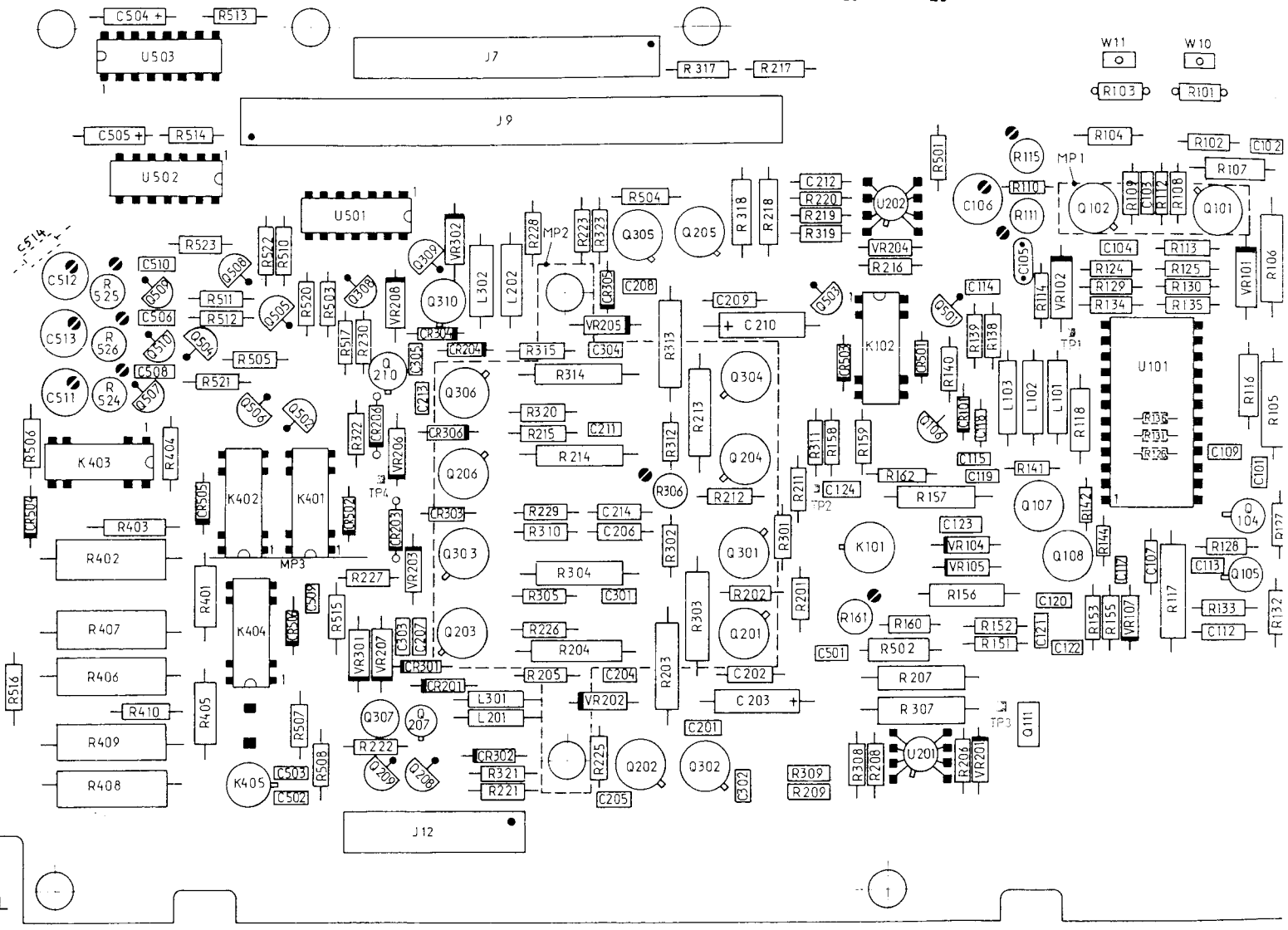

REF DESIG	GRID LOC	REF DESIG	GRID LOC	REF DESIG	GRID LOC	REF DESIG	GRID LOC	REF DESIG	GRID LOC	REF DESIG	GRID LOC	REF DESIG	GRID LOC	REF DESIG	GRID LOC	
1	K3	C103	H2	C116	H4	C206	E4	C304	E3	C514	A3	CR206	C4	CR505	B4	K404
2	k5	C104	H3	C117	H5	C207	C5	C305	C3	C514	A3	CR301	C5	CR506	C5	K405
3	L4	C105	G3	C118	G4	C208	E3	C501	F5	CR1	J3	CR302	D6	J7	D1	L101
4	L6	C106	G2	C119	G4	C209	E3	C502	C6	CR2	J2	CR303	D4	J8	K1	L102
5	12	C107	H5	C120	G5	C210	E3	C503	C6	CR3	J4	CR304	D3	J9	D2	L103
6	12			C121	G5	C211	E4	C504	A1	CR4	J4	CR305	E3	J10	K2	L201
7	14	C109	I4	C122	H5	C212	F2	C505	B2	CR5	J4	CR306	D4	J12	D6	L202
8	14	C110	I4	C123	G4	C213	C4	C506	B3	CR6	J3			K101	F4	L301
9	13	C111	J5	C124	F4	C214	E4	C508	B3	CR7	J2	CR501	G3	K102	F3	L302
10	13	C112	I5	C201	E6	C301	E5	C509	C5	CR8	J3	CR502	C4	K401	C4	MP1
11	J3	C113	I5	C202	F5	C302	F6	C510	E3	CR101	G4	CR503	F3	K402	B4	MP2
101	14	C114	G3	C203	E6	C303	C5	C511	A3	CR201	D5	CR504	A4	K403	A4	MP3
102	12	C115	G4	C204	E5	C205	E6	C512	A3	CR203	C4					
								C513	A3	CR204	D3					

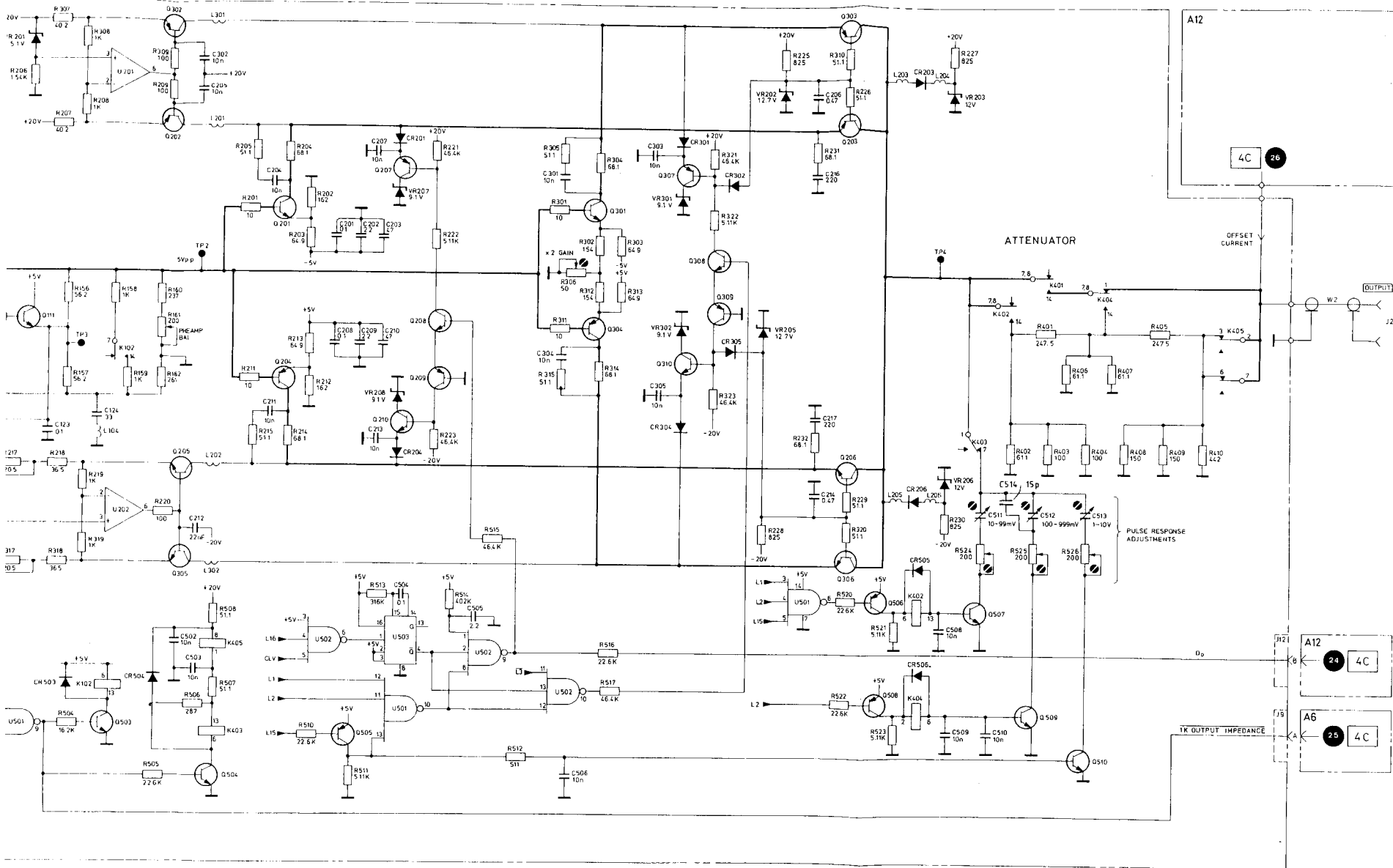

A4
OUTPUT AMPL.

4B

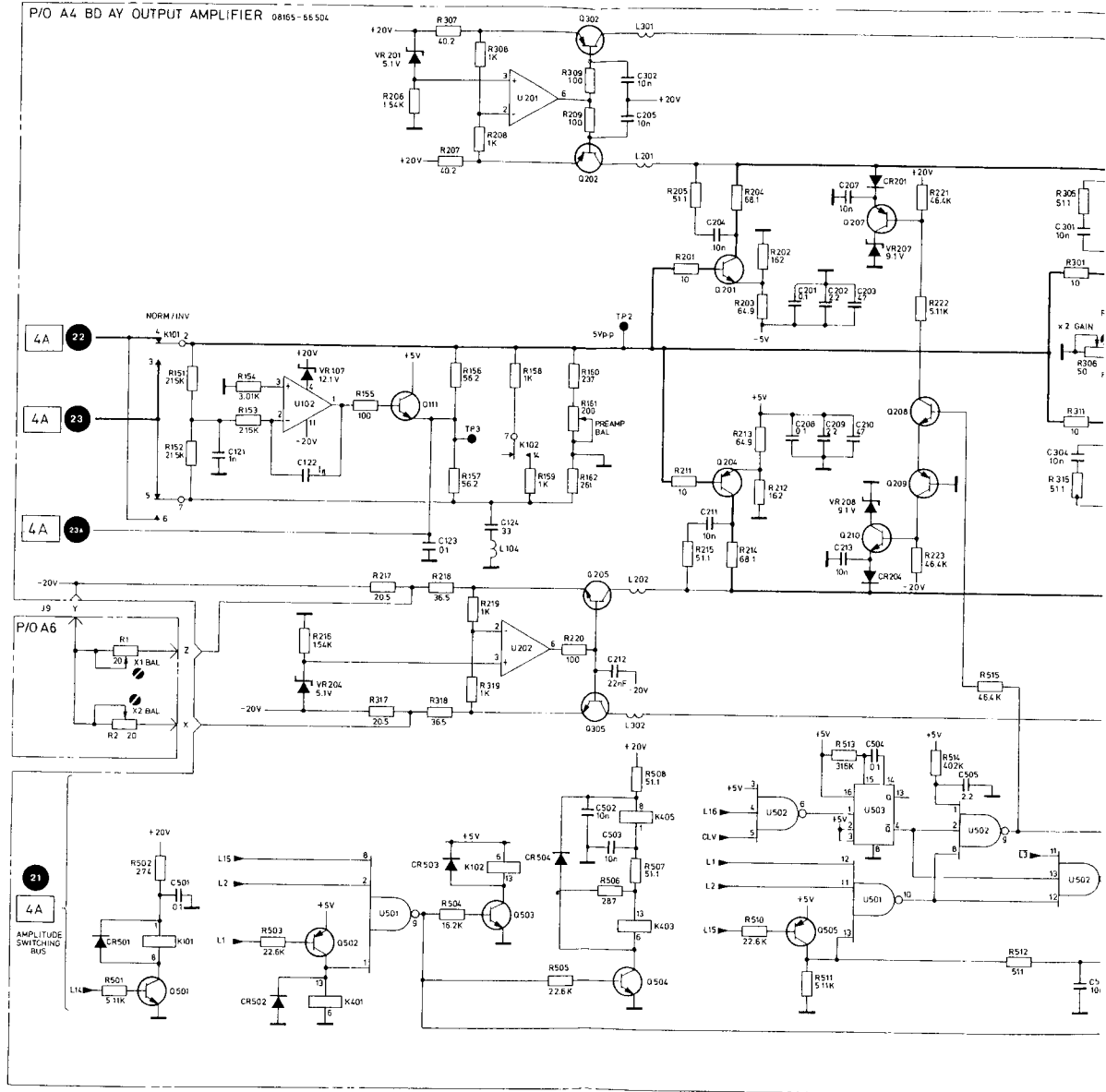

A6 BD AY CONTROL AND SUPPLY 08165-66506

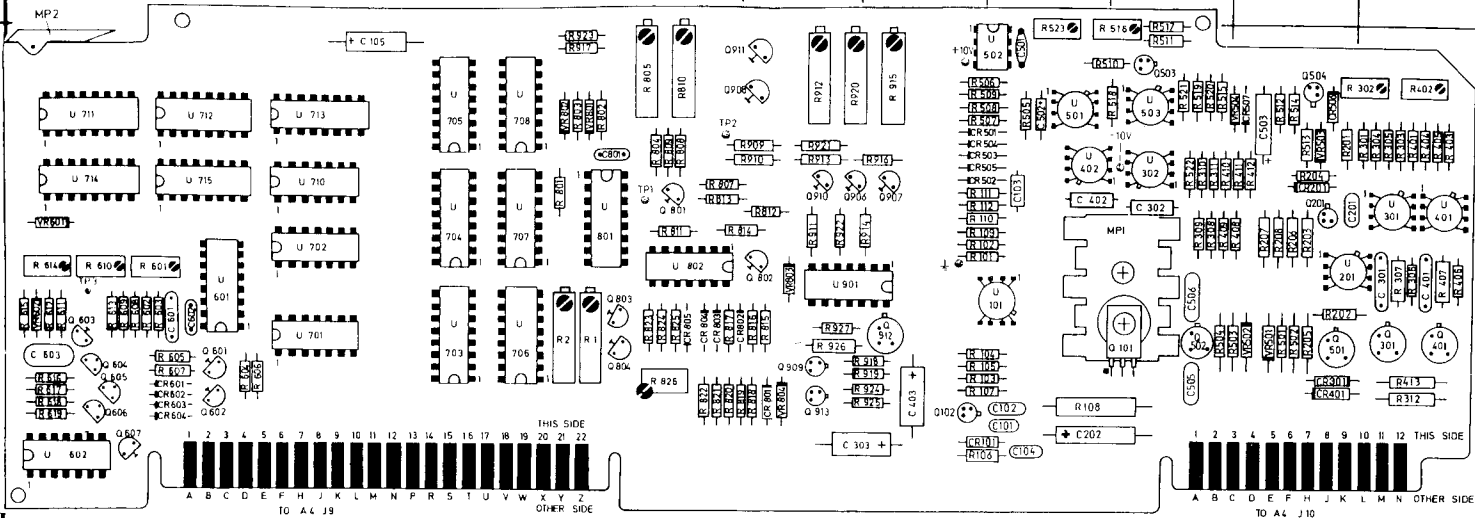

REF DESIG	GRID LOC	REF DESIG	GRID LOC	REF DESIG	GRID LOC	REF DESIG	GRID LOC	REF DESIG	GRID LOC	REF DESIG	GRID LOC	REF DESIG	GRID LOC	REF DESIG	GRID LOC
C101	I5	CR301	L5	Q401	L4	R2	E4	R304	L2	R503	K4	R604	B4	R811	F3
C102	I5	CR401	L4	Q501	L4	R101	I3	R305	L2	R504	J4	R605	B4	R812	F3
C103	I3	CR501	I2	Q502	J4	R102	I3	R306	L3	R505	I2	R606	C4	R813	F3
C104	I5	CR502	I3	Q503	J2	R103	I4	R307	L3	R506	H3	R607	B4	R814	G3
C105	C1	CR503	I2	Q504	K2	R104	I4	R308	K3	R507	I2	R608	B4	R815	G4
C201	L3	CR504	I2	Q601	B4	R105	I4	R309	J3	R508	I2	R609	A4	R816	G4
C202	I5	CR505	I2	Q602	B4	R106	H5	R310	J2	R509	I2	R609	A4	R817	G4
C301	L3	CR506	K2	Q603	A4	R107	I4	R311	K2	R510	J2	R612	A4	R818	G4
C302	J3	CR507	K2	Q604	A4	R108	I5	R312	L5	R511	J2	R613	A4	R819	G4
C303	G5	CR601	B4	Q605	A4	R109	I3	R401	L2	R512	K2	R614	A3	R820	G4
C401	L3	CR602	B3	Q606	A4	R110	I3	R402	L2	R513	K2	R615	A4	R821	F4
C402	I3	CR603	B4	Q607	A5	R111	I3	R403	M2	R514	K2	R616	A4	R822	F4
C403	H4	CR604	B5	Q801	F3	R112	I3	R404	L2	R515	K2	R617	A4	R823	F4
C501	I2	CR801	G4/5	Q802	G3	R201	I3	R405	L2	R516	J1	R618	A4	R824	F4
C502	I2	CR802	G4	Q803	F4	R202	L4	R406	M3	R517	J1	R619	A4	R825	F4
C503	K2	CR803	F4	Q804	F4	R203	K3	R407	L3	R518	J2	R801	E3	R826	F4
C505	J4	CR804	F4	Q906	H3	R204	K3	R408	K3	R519	J2	R802	E2	R909	G2
C506	J4	CR805	F4	Q907	H3	R205	K4	R409	K3	R520	K2	R803	E2	R910	G3
C601	B4	MP1	J3	Q908	G2	R206	K3	R410	K2	R521	J2	R804	F2	R911	G3
C602	B4	MP	A1	Q909	G4	R207	K3	R411	K2	R522	J2	R805	F2	R912	G2
C603	A4	Q101	J4	Q910	G3	R208	K3	R412	K2	R523	I1	R807	F3	R913	G3
C801	E2	Q102	I5	Q911	G2	R301	L2	R413	L4	R601	B3	R808	F2	R914	H3
CR101	I5	Q201	K3	Q913	G4	R302	L2	R501	K4	R602	B4	R809	F2	R915	H2
CR201	K4	Q301	L4	R1	E4	R303	L2	R502	K4	R603	B4	R810	F2	R916	H3

A12 BD AY OFFSET GEN

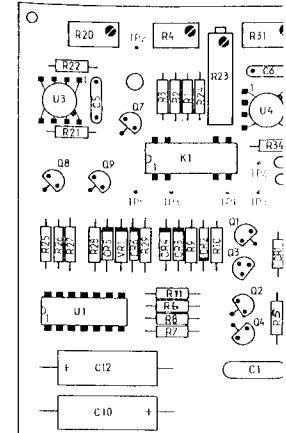

REF DESIG	GRID LOC	REF DESIG	GRID LOC	REF DESIG	GRID LOC
C1	B/C4	CR3	B3	Q8	A
C2	C2	CR4	B3	Q9	A
C3	C2	CR5	A3	Q10	C
C4	C2	CR6	A3	Q11	C
C5	A2	F1	E2	Q12	C
C6	C2	K1	B2	Q13	C
C7	C2	L1	E4	R1	E
C8	C2			R2	E
C9	D4	Q1	B3	R3	E
C10	A4	Q2	B3	R4	E
C11	D4	Q3	B3	R5	C
C12	A4	Q4	B4	R6	E
C13	C4	Q5	D2	R7	E
CR1	C3	O6	D1	R8	E
CR2	B3	Q7	A2		

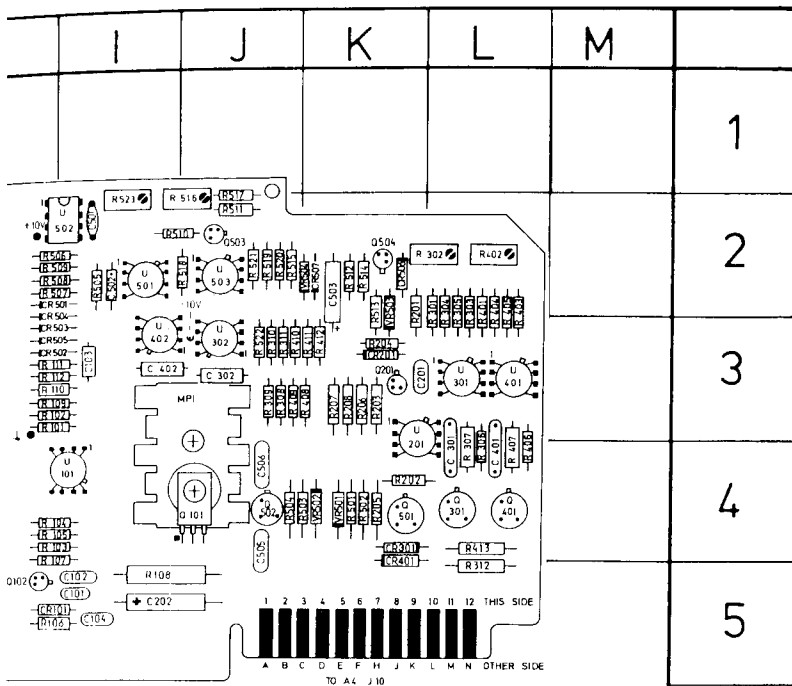

RID OC	REF DESIG	GRID LOC	REF DESIG	GRID LOC	REF DESIG	GRID LOC
3	R917	E1	U602	A5	VR602	A4
3	R918	H4	U701	C4	VR801	E2
3	R919	H4	U702	C3	VR802	E2
3	R920	H2	U703	D4	VR803	G4
4	R911	G3	U704	D3	VR804	G4
4	R912	H2	U705	D2		
4	R921	G2	U706	E4	TP1	F3
4	R922	G3	U707	E3	TP2	F/G2
4	R923	E1	U708	E2	TP3	A3
4	R924	H4	U710	C2		
4	R925	H4	U711	A2		
4	R926	G4	U712	B2		
4	R611	A4	U713	C2		
4	R927	G4	U714	A4		
4	U101	I3	U715	B2/3		
4	U201	L3	U716			
2	U301	L3	U801	E3		
3	U302	J2	U802	F3		
2	U401	L3	U901	G3		
2	U402	I2	VR501	K4		
3	U501	I2	VR502	K4		
3	U502	I1	VR503	K2		
2	U503	J2	VR504	K2		
3	U601	B3	VR601	A3		

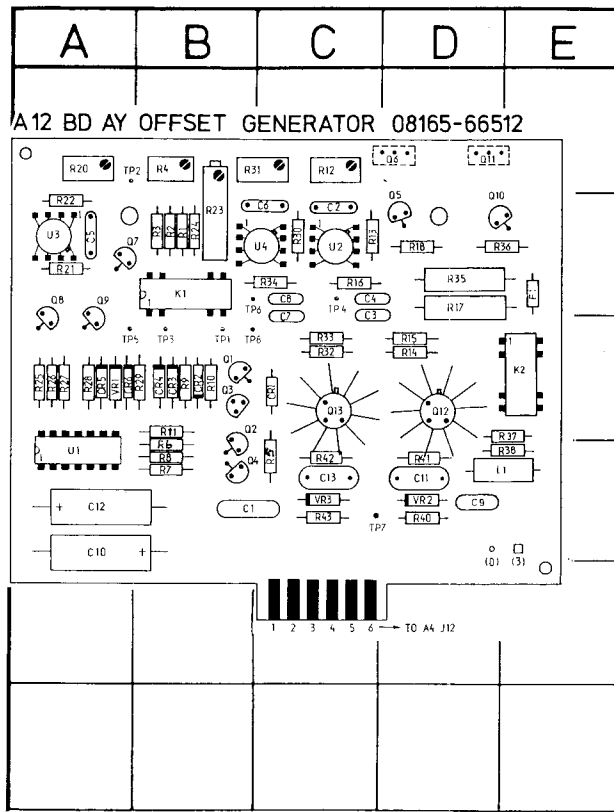

REF DESIG	GRID LOC	REF DESIG	GRID LOC	REF DESIG	GRID LOC	REF DESIG	GRID LOC	REF DESIG	GRID LOC	REF DESIG	GRID LOC
C1	B/C4	CR3	B3	Q8	A2	R9	B3	R24	B2	R40	D4
C2	C2	CR4	B3	Q9	A2	R10	B3	R25	A3	R41	D4
C3	C2	CR5	A3	Q10	D2	R11	B3	R26	A3	R42	C4
C4	C2	CR6	A3	Q11	D1	R12	C1	R27	A3	R43	C4
C5	A2	F1	E2	Q12	D3	R13	C2	R28	A3	U1	A4
C6	C2	K1	B2	Q13	C3	R14	D3	R29	B3	U2	C2
C7	C2	L1	E4	R1	B2	R15	D3	R30	C2	U3	A2
C8	C2			R2	B2	R16	C2	R31	B/C1	U4	C2
C9	D4	Q1	B3	R3	B2	R17	D2	R32	C3	VR1	A3
C10	A4	Q2	B3	R4	B1	R18	D2	R33	C3	VR2	D4
C11	D4	Q3	B3	R5	C4			R34	C2	VR3	C4
C12	A4	Q4	B4	R6	B4	R20	A1	R35	D2		
C13	C4	Q5	D2	R7	B4	R21	A2	R36	E2		
CR1	C3	Q6	D1	R8	B4	R22	A2	R37	E3		
CR2	B3	Q7	A2			R23	B1/2	R38	E4		

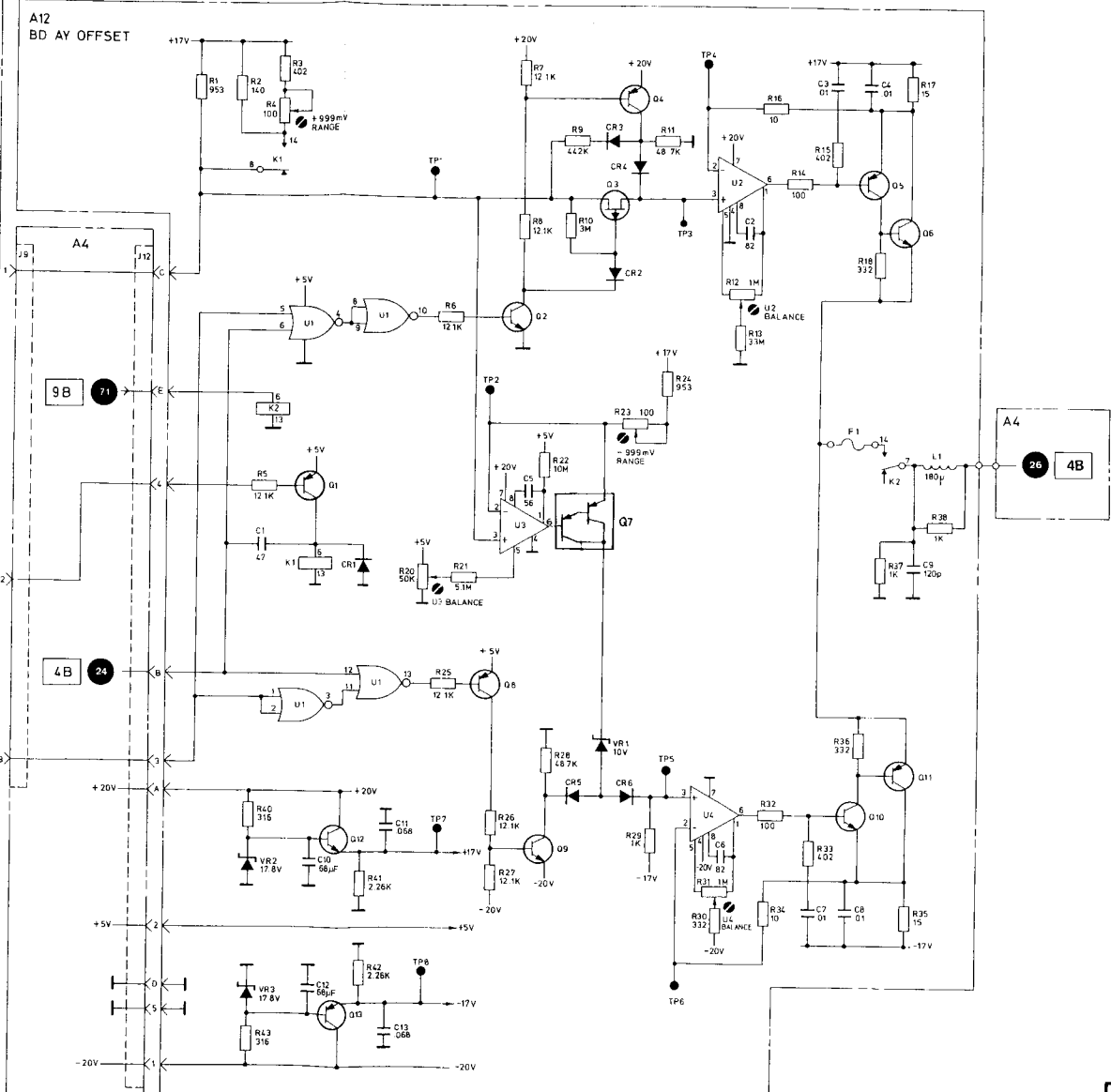
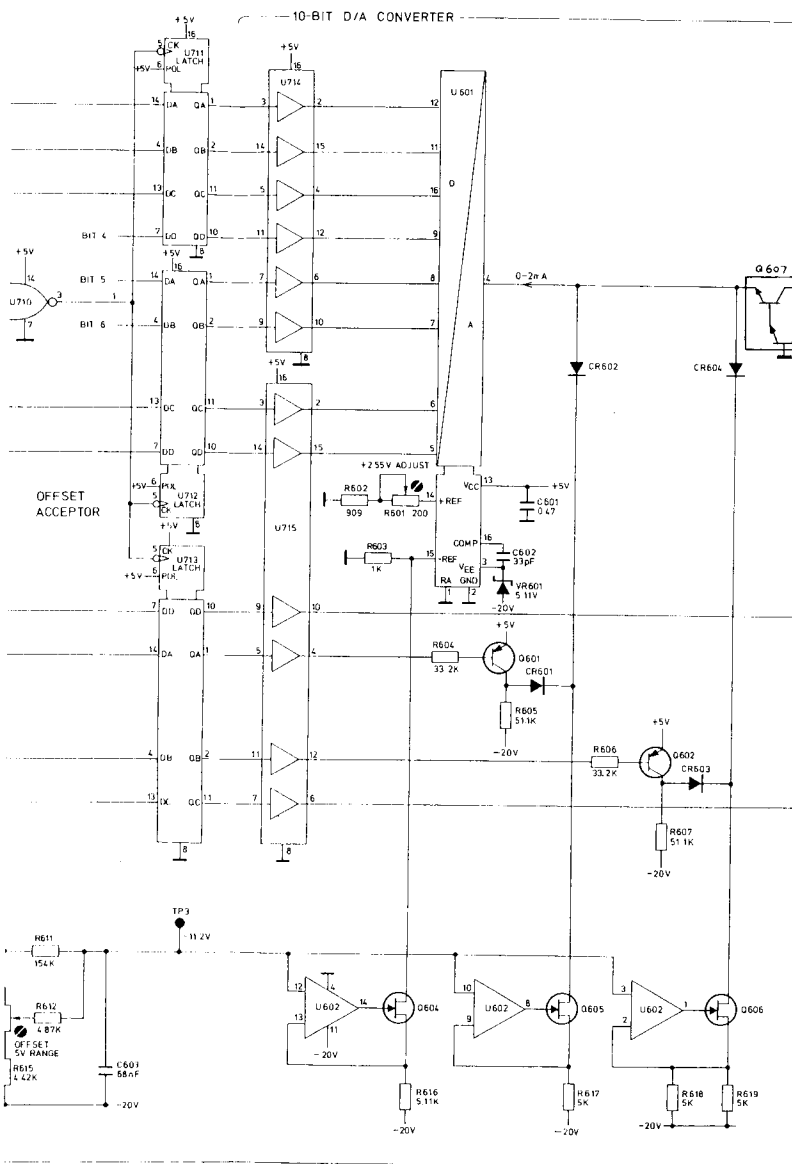

A6, A12 OFFSET



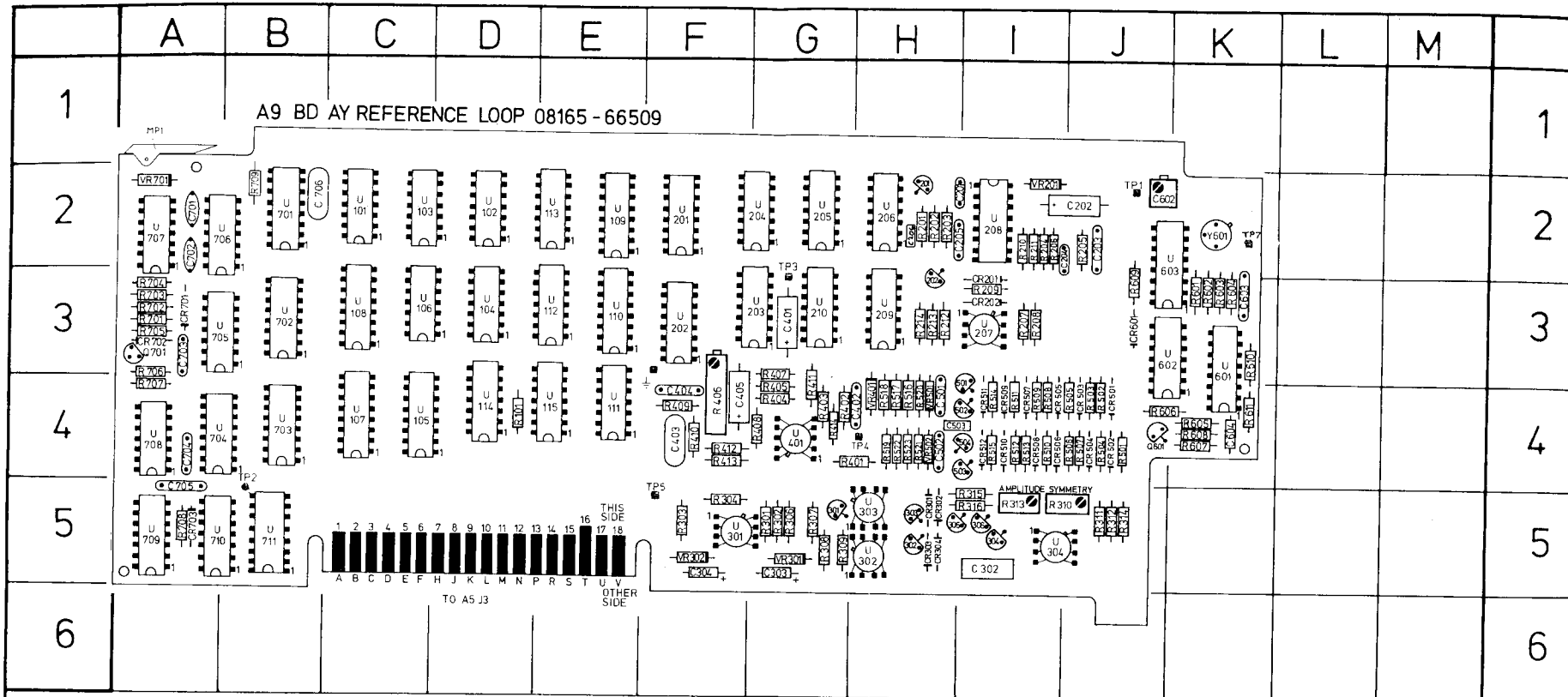

REF DESIG	GRID LOC	REF DESIG	GRID LOC	REF DESIG	GRID LOC	REF DESIG	GRID LOC	REF DESIG	GRID LOC	REF DESIG	GRID LOC	REF DESIG	GRID LOC	REF DESIG	GRID LOC	REF DESIG	GRID LOC	REF DESIG	GRID LOC	REF DESIG	GRID LOC						
C201	I2	C602	J2	CR501	J4	CR703	A5	Q701	A3	R214	H3	R316	I5	R501	J4	R516	H4	R608	K4	U102	D2	U202	F3	U602	J3	VR302	F5
C202	I2	C603	K2	CR502	J4			R101	D4	R301	G5	R401	G4	R502	J4	R517	H4	R609	J2	U103	C2	U203	G3	U603	J2	VR401	H4
C203	J2	C604	K4	CR503	J4	Q201	H2	R201	H2	R302	G5	R402	G4	R503	J4	R518	H4	R610	K3	U104	D3	U204	G2	U701	B2	VR501	H4
C204	J2	C701	A2	CR504	J4	Q202	H2	R202	H2	R303	F5	R403	G4	R504	J4	R519	H4	R611	K4	U105	C4	U205	G2	U702	B3	VR502	H4
C205	I2	C702	A2	CR505	J4	Q301	G5	R203	H2	R304	F5	R404	G4	R505	J4	R520	H4			U106	C3	U206	H2	U703	B4	VR701	A2
C302	I5	C703	A3	CR506	J4	Q302	H5	R204	I2	R306	G5	R405	G4	R506	J4	R521	H4	R701	A3	U107	C4	U207	I3	U704	A4	Y601	K2
C303	G5	C704	A4	CR507	J4	Q303	H5	R205	J2	R307	G5	R406	F3	R507	J4	R522	H4	R702	A3	U108	C3	U208	I2	U705	A3	TP1	J2
C304	F5	C705	A5	CR508	J4	Q304	I5	R206	I2	R308	G5	R407	G3	R508	I4	R523	H4	R703	A3	U109	E2	U209	H3	U706	A2	TP2	B5
C401	G3	C706	B2	CR509	J4	Q305	I5	R207	I3	R309	G5	R408	G4	R509	I4	R601	K2	R704	A3	U110	E3	U210	G3	U707	A2	TP3	G3
C402	H4	CR201	I2	CR510	J4	Q306	I5	R208	I3	R310	I/J5	R409	F4	R510	I4	R602	K3	R705	A3	U111	E3	U301	F5	U708	A4	TP4	H4
C403	F4	CR202	I3	CR511	J4	Q501	I3/4	R209	I3	R311	J5	R410	F4	R511	I4	R603	K2	R706	A3	U112	E3	U302	H5	U709	A5	TP7	K2
C404	F4	CR301	H5	CR512	J4	Q502	I4	R210	I2	R312	J5	R411	G3	R512	I4	R604	K2	R707	A4	U113	E3	U303	H5	U710	A5		
C405	F3	CR302	H5	CR601	I3	Q503	I4	R211	I2	R313	I5	R412	F4	R513	I4	R605	K4	R708	A5	U114	D3	U304	H5	U711	B5		
C501	H4	CR303	H5	CR701	A3	Q504	I4	R212	H3	R314	J5	R413	F4	R514	I4	R606	J/K4	R709	B2	U115	E3	U401	G4	VR201	I2		
C502	H4	CR304	H5	CR702	A3	Q601	J4	R213	H3	R315	I5	R414	G4	R515	I4	R607	K4	U101	C2	U201	F2	U601	K3	VR301	G5		
C503	H4	C206	H2																								

5A

P/O A9 BD AY REF LOOP 08165 - 66509

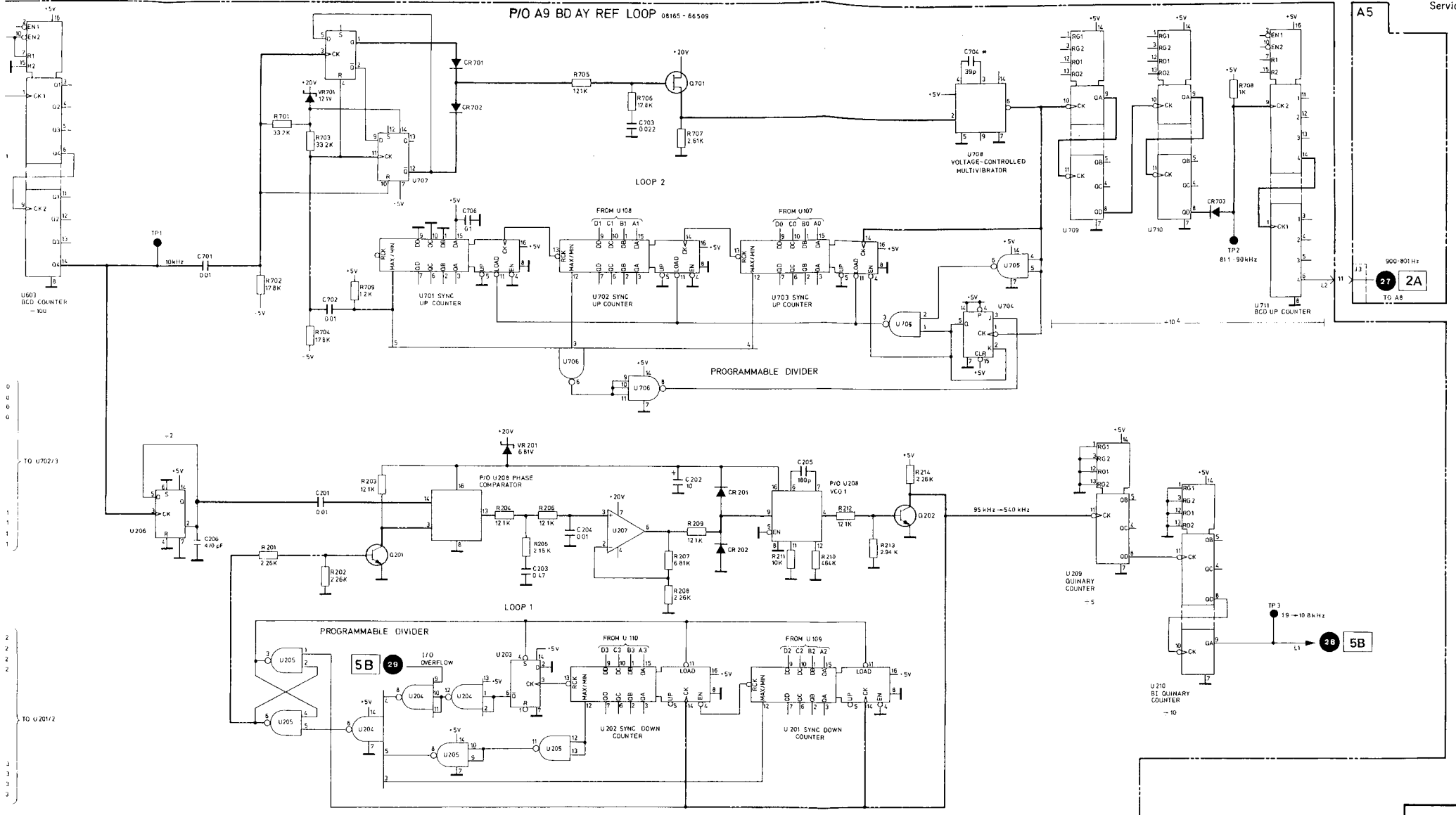

A5

900.801 kHz

2A

TO A8

2B

5B

19 - 10.8 kHz

U210
B1 QUINARY COUNTER

A9
PLL FREQ REF
REF DIVIDERS

5A

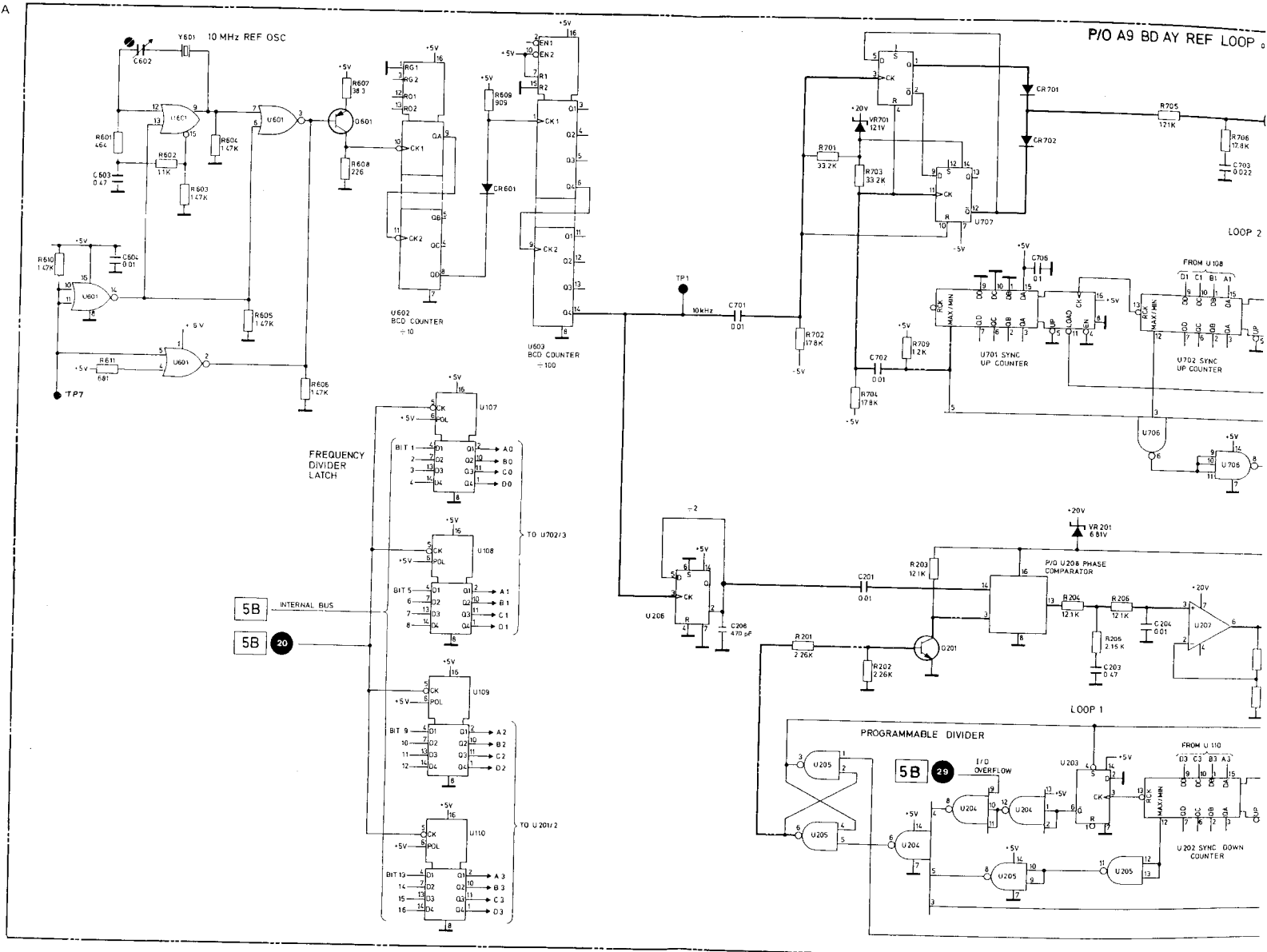

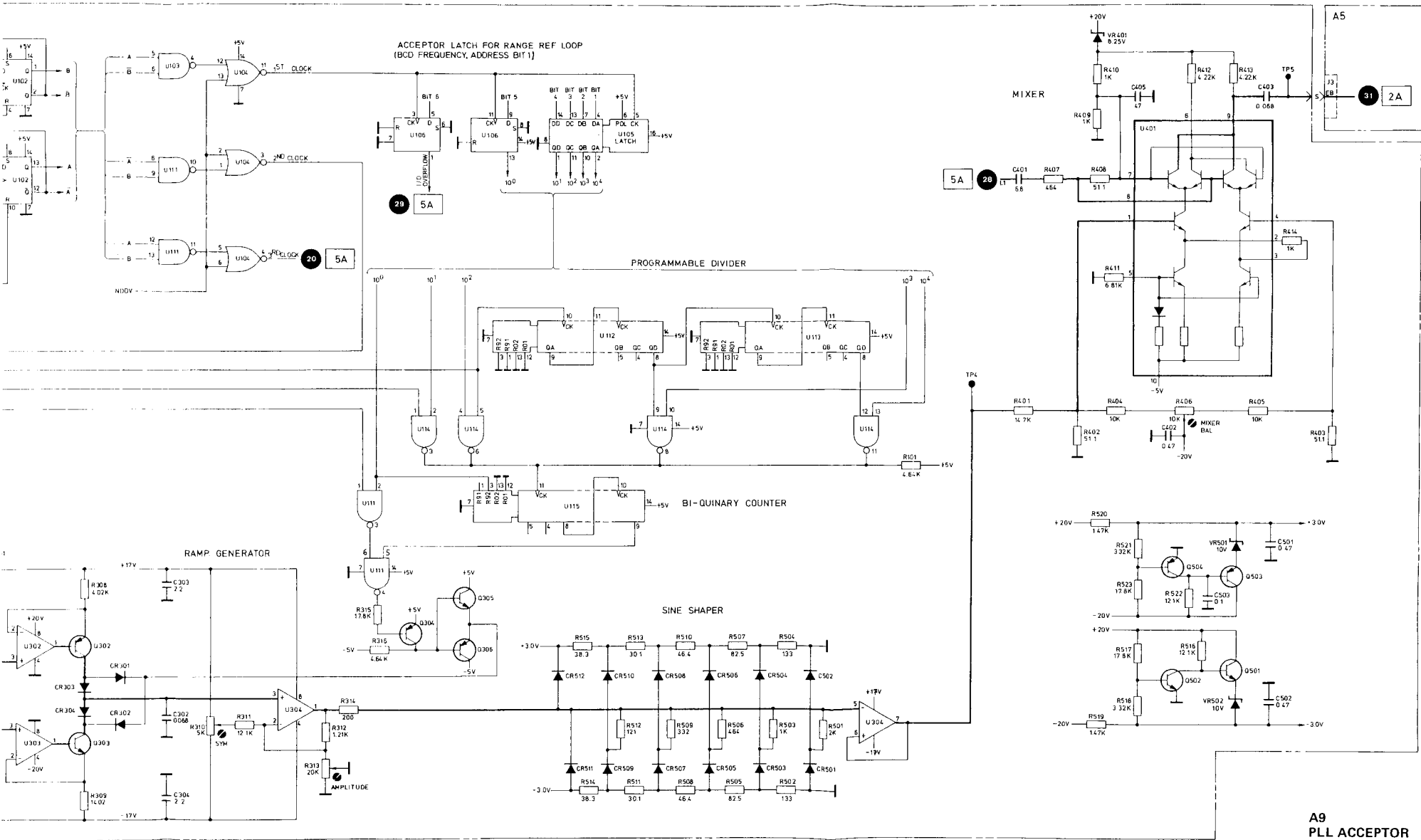

A9 PLL ACCEPTOR PLL MIXER



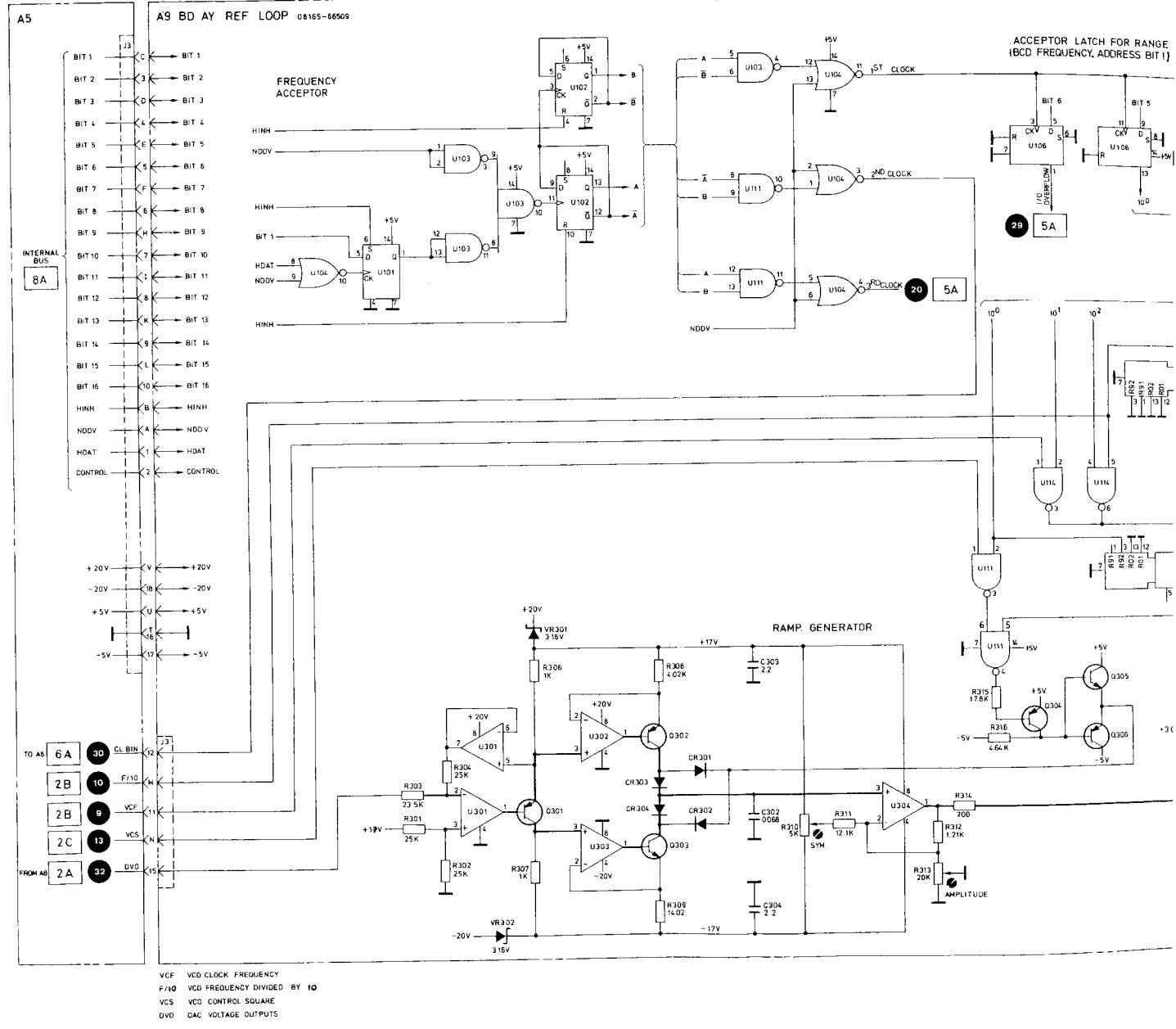

20 OPTION 001

TH

BUFFERS

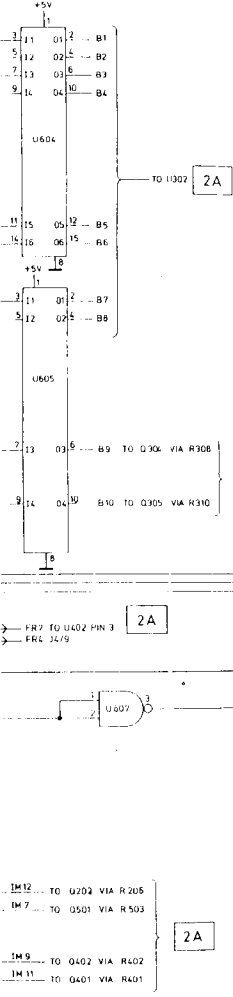

WAVEFORM ACCEPTOR

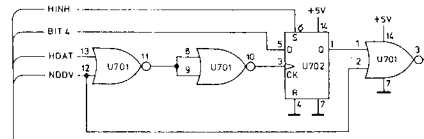

WAVEFORM LATCH

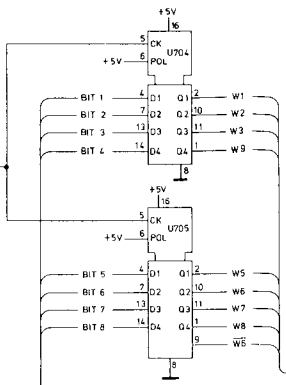

FREQUENCY RANGE ACCEPTOR

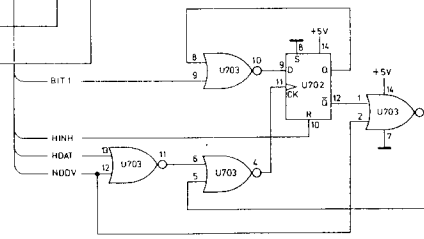

FREQUENCY RANGE LATCH

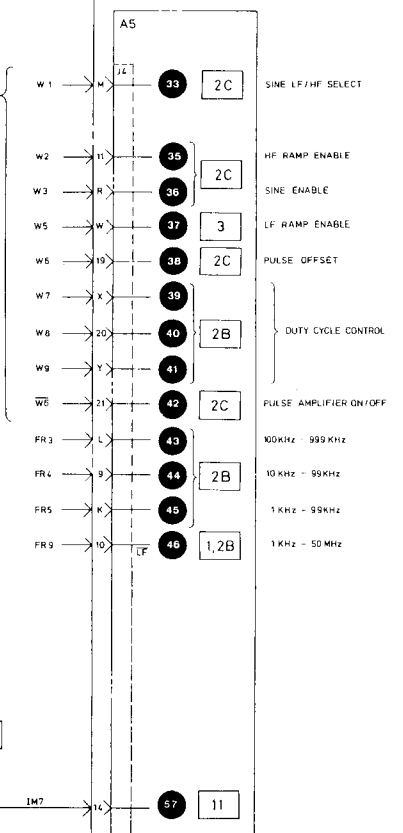
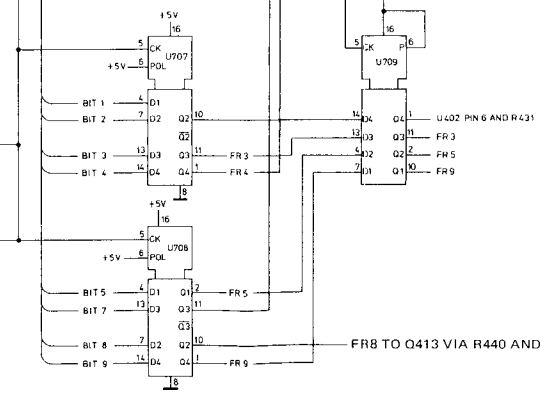

A8 VCO CONTROL



Option 002

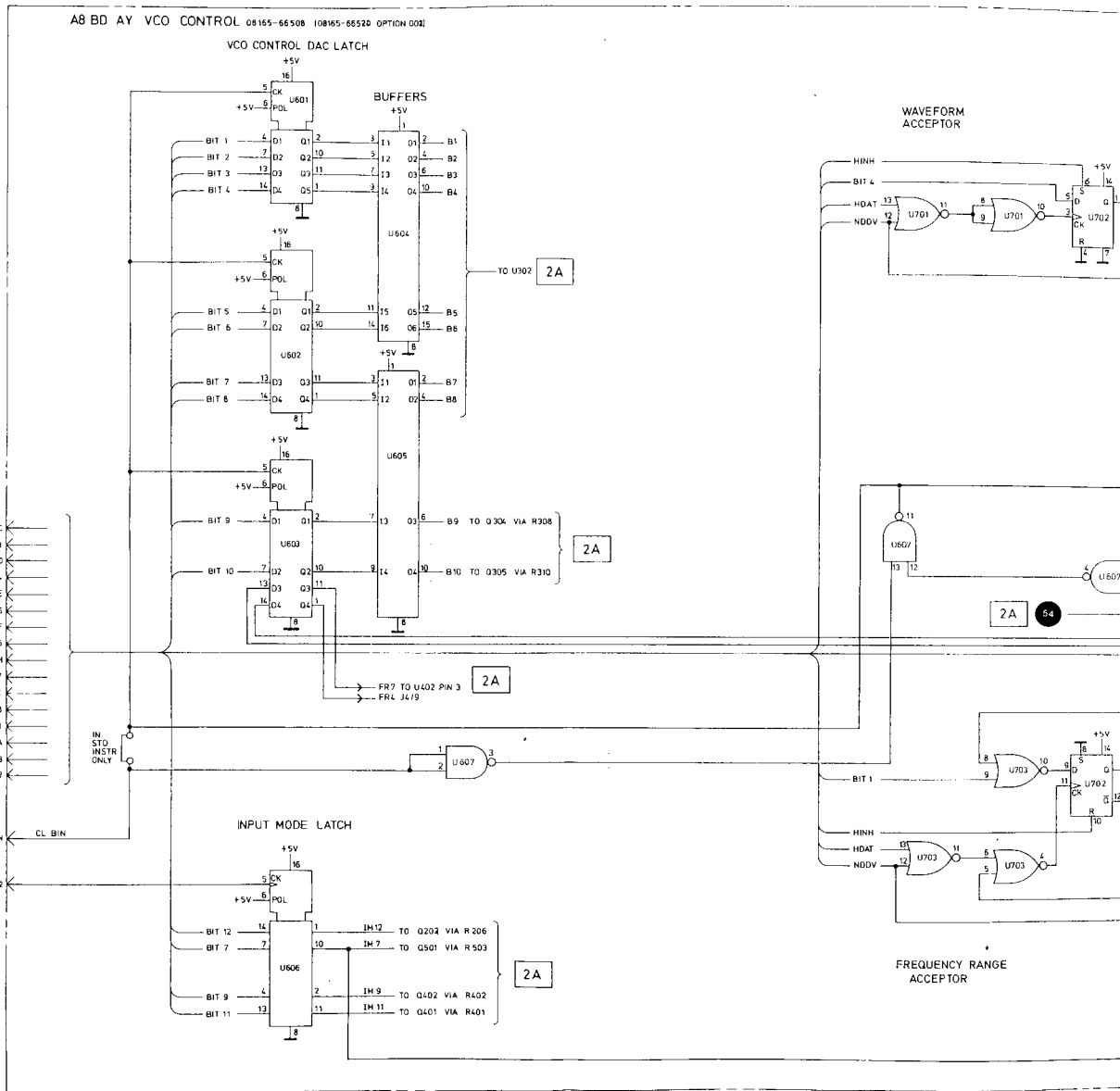
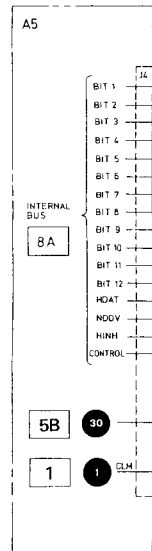

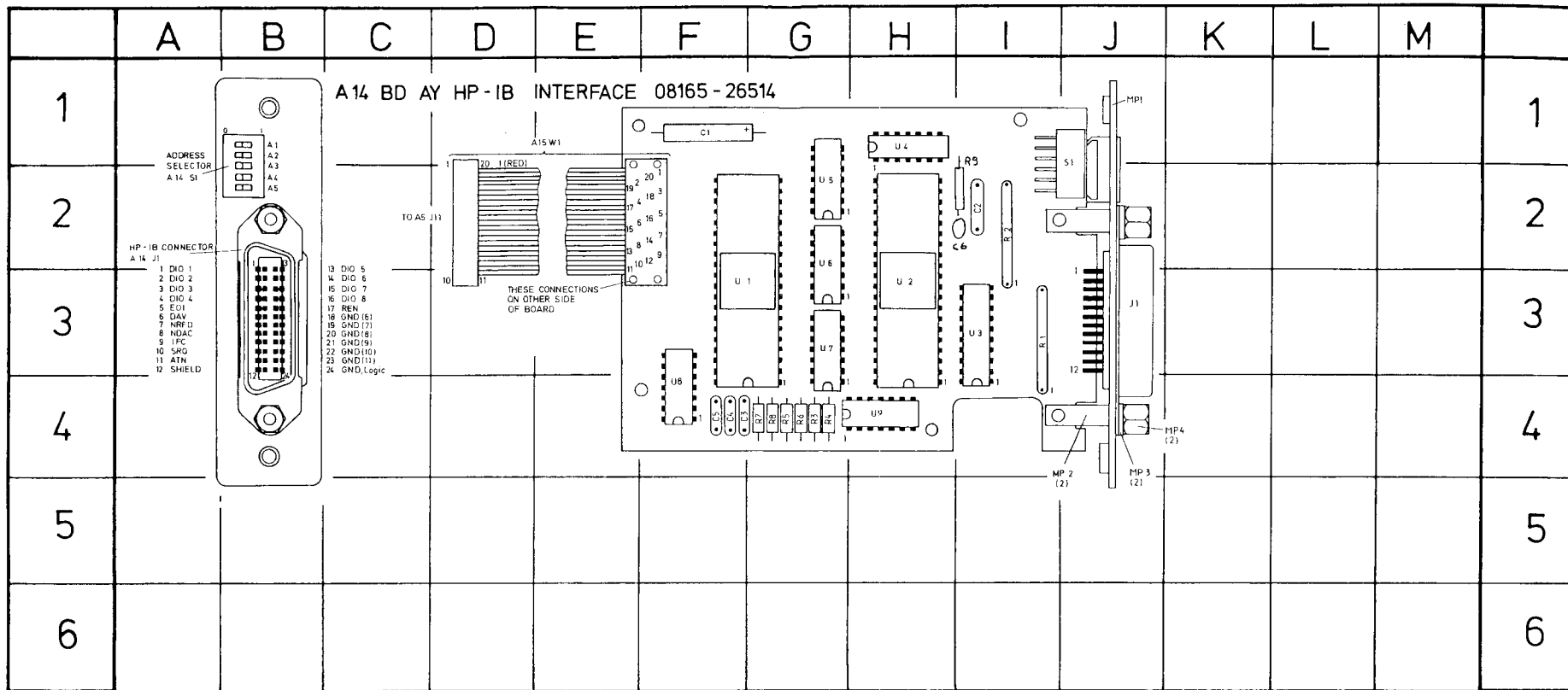

REF	GRID	REF	GRID
DESIG	LOC	DESIG	LOC
C1	F1	R6	G4
C2	I2	R7	G4
C3	F4	R8	G4
C4	F4	R9	H2
C5	F4	S1	J2
C6	H2	U1	F3
J1	F2	U2	H3
MP1	J1	U3	I3
MP2	J4	U4	H1
MP3	J4	U5	G2
MP4	J4	U6	G2
R1	I4	U7	G3
R2	I2	U8	F4
R3	G4	U9	H4
R4	G4	W1	E2
R5	G4		

7

08165 - 86514

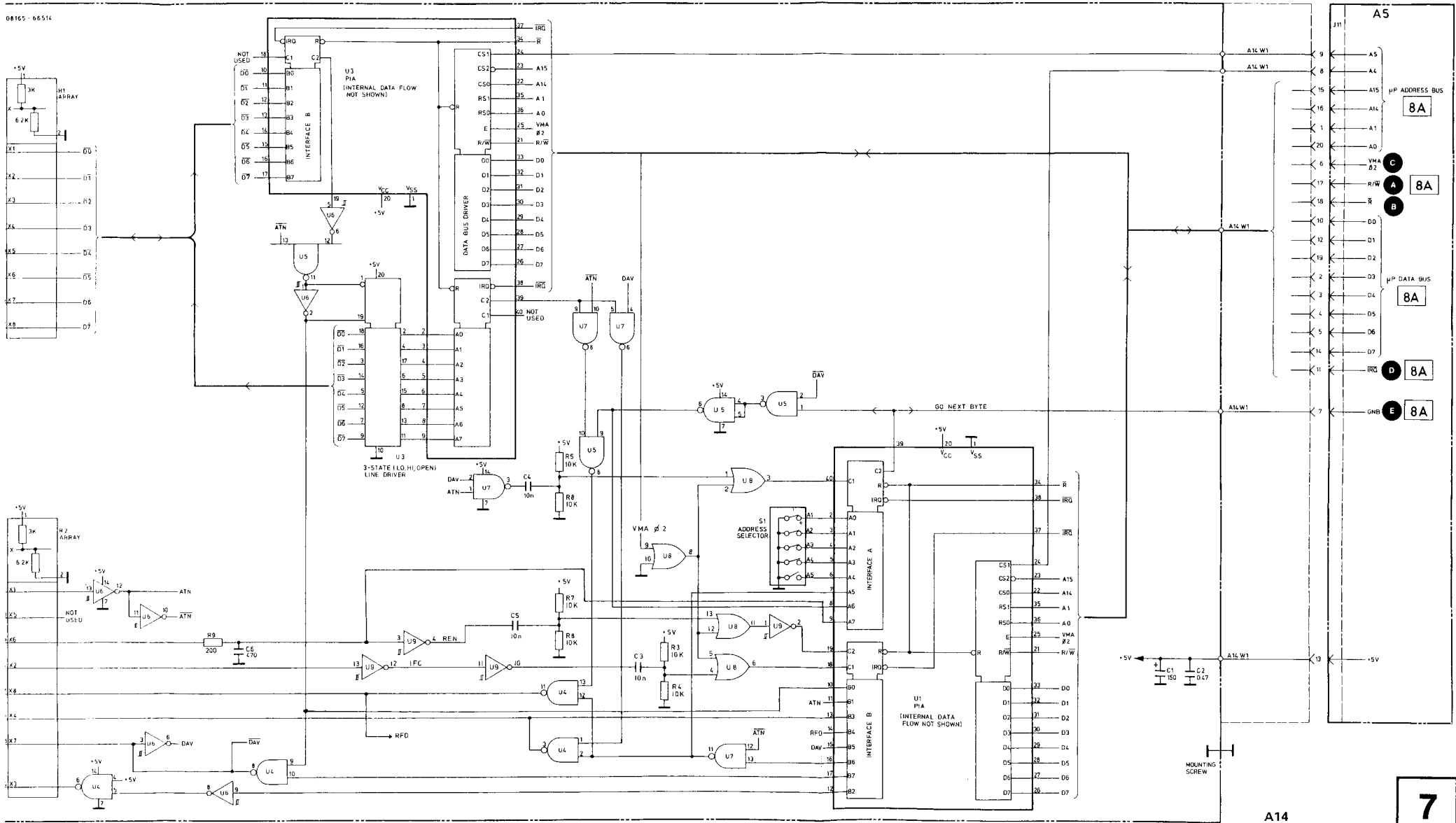

A14 HP-IB INTERFACE

7

C D E F G H I J K L M N O P

PROCESSOR 08165 - 66523

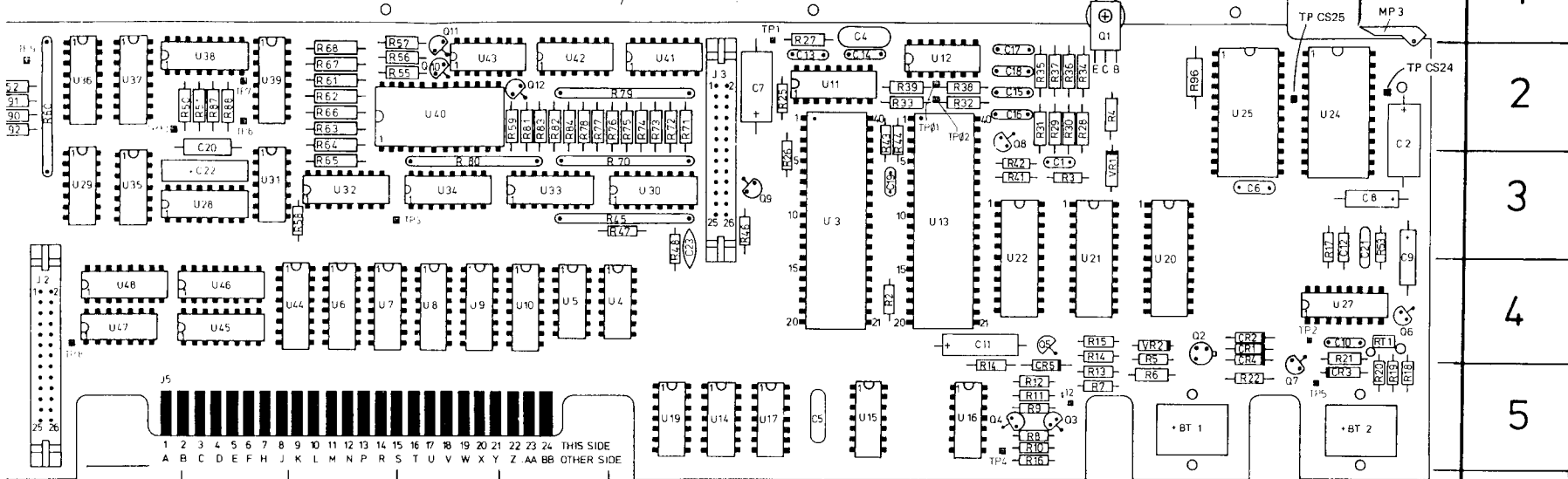

1
2
3
4
5
6

GRID LOC	REF DESIG	GRID LOC	REF DESIG	GRID LOC	REF DESIG	GRID LOC	REF DESIG	GRID LOC	REF DESIG	GRID LOC	REF DESIG	GRID LOC	REF DESIG	GRID LOC	REF DESIG	GRID LOC	REF DESIG	GRID LOC					
C4	Q11	G2	R14	M4	R31	M2	R47	I3	R64	F2	R80	G3	U2	C5	U17	J5	U32	F3	U47	D4	TP1	J2	
J2	Q12	H2	R15	M4	R32	L2	R48	I3/4	R65	F3	R81	H2	U3	K3	U18	J5	U33	H3	U48	D4	TP2	O4	
A4	R1	A4/5	R16	M5	R33	K/L2	R50	E2	R66	F2	R82	H2	U4	I4	U19	I5	U34	G3	U49	B2	TP3	G3	
M1	R2	K4	R17	P3/4	R34	M2	R51	E2	R67	F2	R83	H2	U5	H4	U20	N3	U35	D3	U50	B2	TP4	L5	
	R3	M3	R18	P5	R35	M2	R52	C2	R68	F2	R84	H2	U6	F4	U21	M3	U36	D2	U51	B4	TP5	O5	
M1	R4	M2	R19	P5	R36	M2	R53	P3/4	R69	H3	R87	E2	U7	F4	U22	L3	U37	D2	U52	B3	TP6	E2	
N4	R5	N4	R20	P5	R37	M2	R55	G2	R71	I2	R88	E2	U8	G4	U23	L3	U38	E2	U53	B4	TP7	E2	
M5	R6	N5	R21	P5	R38	L2	R56	G2	R72	I2	R89	C2	U9	G4	U24	O2	U39	E2	U54	B3	TP8	O4	
M5	R7	M5	R22	O5	R39	K/L2	R57	G2	R73	I2	R91	C2	U10	H4	U25	O2	U40	G2	U55	A2	TP9	C2	
N5	R8	M5	R25	J2	R41	L/M3	R58	F3	R74	I2	R92	C2	U11	K2	U26	O2	U41	I2	U56	A3	TP10	D2	
P4	R9	M5	R26	J2/3	R42	L/M3	R59	H2	R75	I2	R93	A2	U12	L2	U27	O4	U42	H/I/2	VR1	M3			
O5	R10	M5	R27	J/K2	R43	K2	R60	C2	R76	I2	R94	A2	U13	L3	U28	E3	U43	G/H2	VR2	N4			
L2	R11	M5	R28	M2	R44	K2	R61	F2	R77	I2	R95	A2	U14	J5	U29	D3	U44	F4					
J3	R12	M5	R29	M2	R45	H/I/3	R62	F2	R78	H2	R96	N2	U15	K5	U30	I3	U45	E4					
G2	R13	M5	R30	M2	R46	J3	R63	F2	R79	H2	RT1	P4	U16	I5	U31	E3	U46	E4					
											U1	B5											

1 2 3 4 5 6 7 8 9 10 11 12 13 14 15 16 17 18 19 20 21 22 23 24 THIS SIDE
A B C D E F H J K L M N P R S T U V W X Y Z AA BB OTHER SIDE

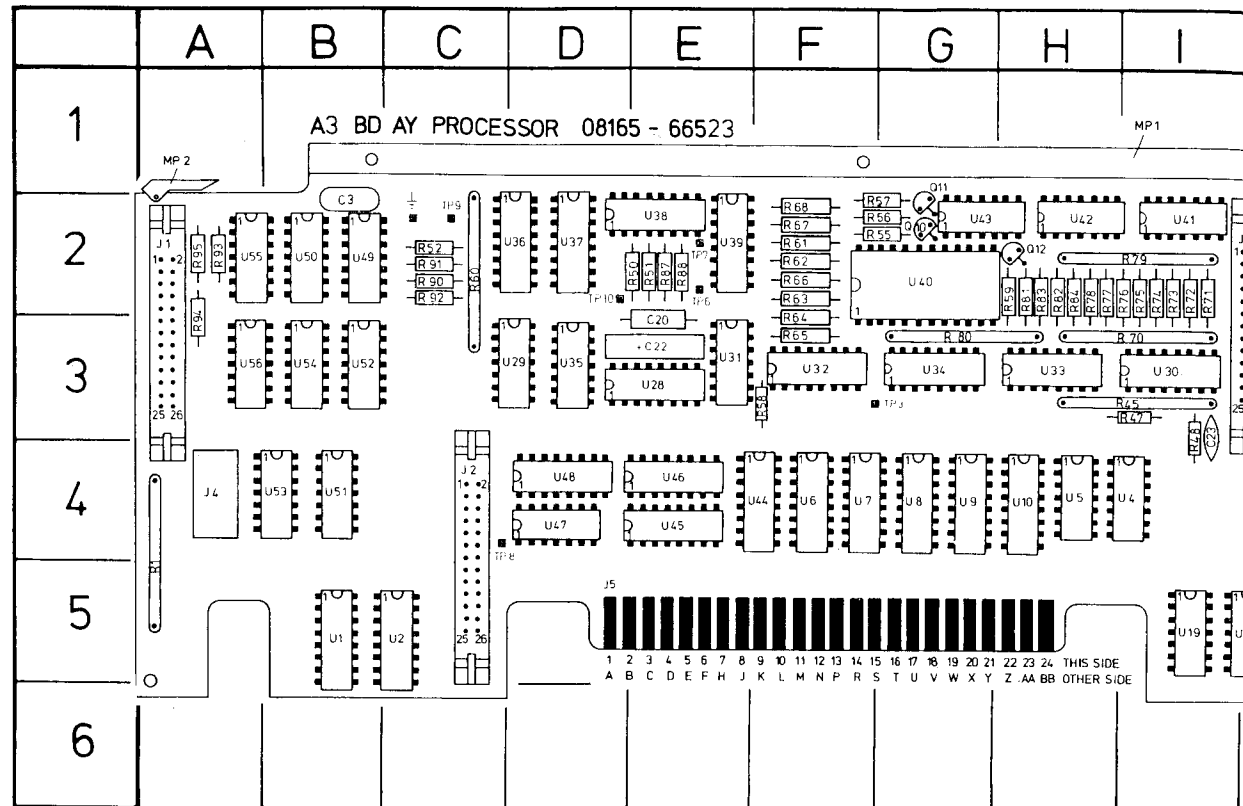

REF DESIG	GRID LOC	REF DESIG	GRID LOC	REF DESIG	GRID LOC	REF DESIG	GRID LOC	REF DESIG	GRID LOC	REF DESIG	GRID LOC	REF DESIG	GRID LOC	REF DESIG	GRID LOC
BT1	K5	C13	J2	J2	C4	Q11	G2	R14	M4	R31	M2	R47	I3	R64	F2
BT2	M5	C14	K2	J3	J2	Q12	H2	R15	M4	R32	L2	R48	I3/4	R65	F3
C1	M3	C15	L2	J4	A4	R1	A4/5	R16	M5	R33	K/L2	R50	E2	R66	F2
C2	P2	C16	L2	MP1	M1	R2	K4	R17	P3/4	R34	M2	R51	E2	R67	F2
C3	B2	C17	L2	MP2		R3	M3	R18	P5	R35	M2	R52	C2	R68	F2
C4	K1	C18	L2	Q1	M1	R4	M2	R19	P5	R36	M2	R53	P3/4	R70	H3
C5	K5	C19	K3	Q2	N4	R5	N4	R20	P5	R37	M2	R55	G2	R71	I2
C6	Q3	C20	E3	Q3	M5	R6	N5	R21	P5	R38	L2	R56	G2	R72	I2
C7	J2	C21	P3	Q4	M5	R7	M5	R22	O5	R39	K/L2	R57	G2	R73	I2
C8	P3	C22	E3	Q5	N5	R8	M5	R23	J2	R41	L/M3	R58	F3	R74	I2
C9	P3	C23	I3	O6	P4	R9	M5	R26	J2/3	R42	L/M3	R59	H2	R75	I2
C9		CR1	O4	O7	O5	R10	M5	R27	J/K2	R43	K2	R60	C2	R76	I2
C10	P4	CR2	O4	Q8	L2	R11	M5	R28	M2	R44	K2	R61	F2	R77	I2
C11	L4	CR3	P5	Q9	J3	R12	M5	R29	M2	R45	H/I3	R62	F2	R78	H2
C12	P3	CR4	O4	Q10	G2	R13	M5	R30	M2	R46	J3	R63	F2	R79	H2
		J1	A2												

8A

SERVICE BLOCK 5 MICROPROCESSOR AND DISPLAY A1, A2, A3

8A

8B

8C

Service Philosophy:

The controller board A3 is on the blue stripe exchange program. If trouble appears in this area, check all basic conditions (see troubleshooting). If the fault seems to be the μ P loop, replacement via the blue stripe exchange program is recommended.

THEORY OF OPERATION

Controller

The controller is the data and instruction center of the 8165A Programmable Signal Source. It generates the control information required by the instrument dependent from one of two sources:

- a) Keyboard inputs when in manual control.
- b) HP-IB inputs when in remote control.

During operation inputs from one of these sources program the desired output parameters. When the instrument is in remote control mode, the keyboard switches are disabled and output parameters can be entered only through the HP-IB interface.

Output signals from the controller can be divided into three groups-control, data and address (the control determines whether data or address, load data or address, inhibit/reset receiver circuit).

The controller is comprised of the following major segments:
(See Figure 8-5-1. Basic Controller Structure).

- a) Microprocessor Unit (MPU)
- b) Read Only Memory (ROM)
- c) Random Access Memory (RAM)
- d) HP-IB Interface Section (Peripheral Interface Adapter, PIA)
- e) Control Line and Data Interface
- f) Keyboard Interface

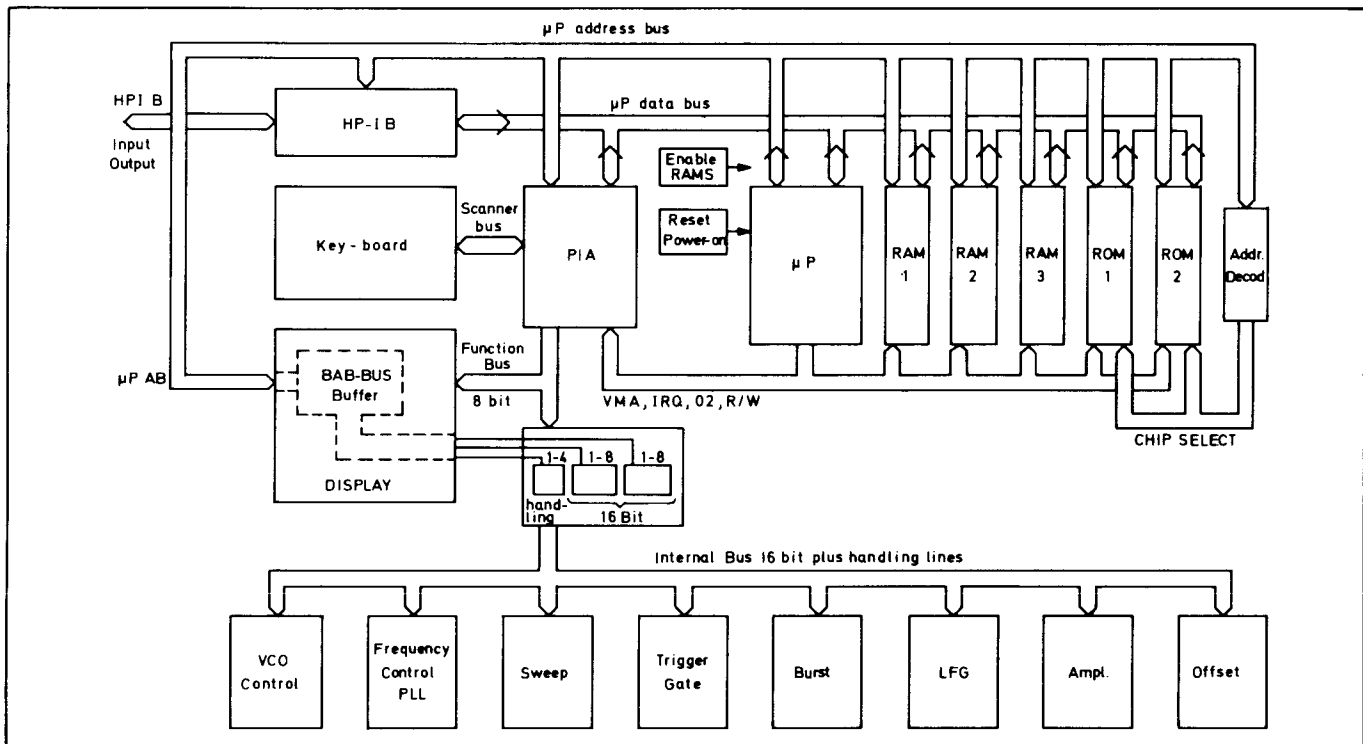

Figure 8-5-1. Controller Block Diagram

Microprocessor Unit (MPU)

The purpose of the MPU is to perform the functions (routines) programmed into the ROM. Figure 8-5-1 indicates the input and output signals of the MPU. The MPU is driven by a two-phase clock (two clock signals which are non-overlapping). It contains two buses, an eight-bit data bus and a sixteen-bit address bus. The function of the address bus is to address a particular location in memory, either ROM, RAM or the PIA. The address decoder, also connected to the address bus, enables one of these elements. In the case of a RAM or the PIA (Peripheral Interface Adapter), the MPU also controls whether it is in the read or write mode. Data can then be transmitted in either direction over the eight-bit bi-directional data bus connected to the MPU.

Read-Only Memory (ROM)

The Read Only Memory (ROM) is a type of memory that cannot be written into but only read from. The data pattern of the ROM is fixed at the time of manufacture according to the design specifications of its application. Data from a particular memory location can be read by addressing the memory location and enabling the ROM. Addressing and reading data take place on the two separate buses of the ROM, the address bus and the data bus.

Random Access Memory (RAM)

Random Access Memory (RAM) is the "scratchpad" element of the controller. The memory locations of a RAM do not normally contain permanent data. Data can be written into a memory location and then read out again at a later time. Data written into a memory location destroys the data previously stored in that location which is no longer needed, thus the term "scratchpad". Data stored in a RAM is also normally destroyed any time power is switched off or removed from the instrument. However, with the 8165A there is a non-volatile RAM section (due to battery back-up) which stores the current operating data and the 9 parameter sets.

RAM's contain two buses - an address bus for the addressing of a particular memory location, and a bi-directional data bus for transmitting data in the read mode or receiving data in the write mode. Both RAM buses are connected to the address and data buses of the MPU. The address decoder is also connected to lines of the address bus and controls the enabling of each RAM. Read or write functions are controlled by a single line from the MPU. With this configuration, the MPU can enable a particular RAM and address a particular memory location for either a read or write function.

Peripheral Interface Adapter (PIA)

3 PIA's are used in the 8165A

- A. One PIA (A3U3) is part of the internal device bus and keyboard scanner bus and provides the communication link between the MPU and the two slaves.
- B. Two PIA's (A14 U1, U3) are part of the HP-IB section and provide the communication link between the MPU and the outside world of HP-IB.
- C. From the MPU's viewpoint, the PIA is simply memory locations that are treated in the same manner as any other read/write memory. The read/write function is controlled by a single line (R/W) from the MPU. This is the same line used to control the read/write function of the RAM's.

Control Line and Data Interface (Schematic 8A)

The instrument uses an internal 16-bit parallel Device Bus. The function of this bus is controlled by 3 Device Bus management lines. The control line latches and the data latches, which terminate the Data-Bus, are selected through Address Enable Lines over the Address Decoder.

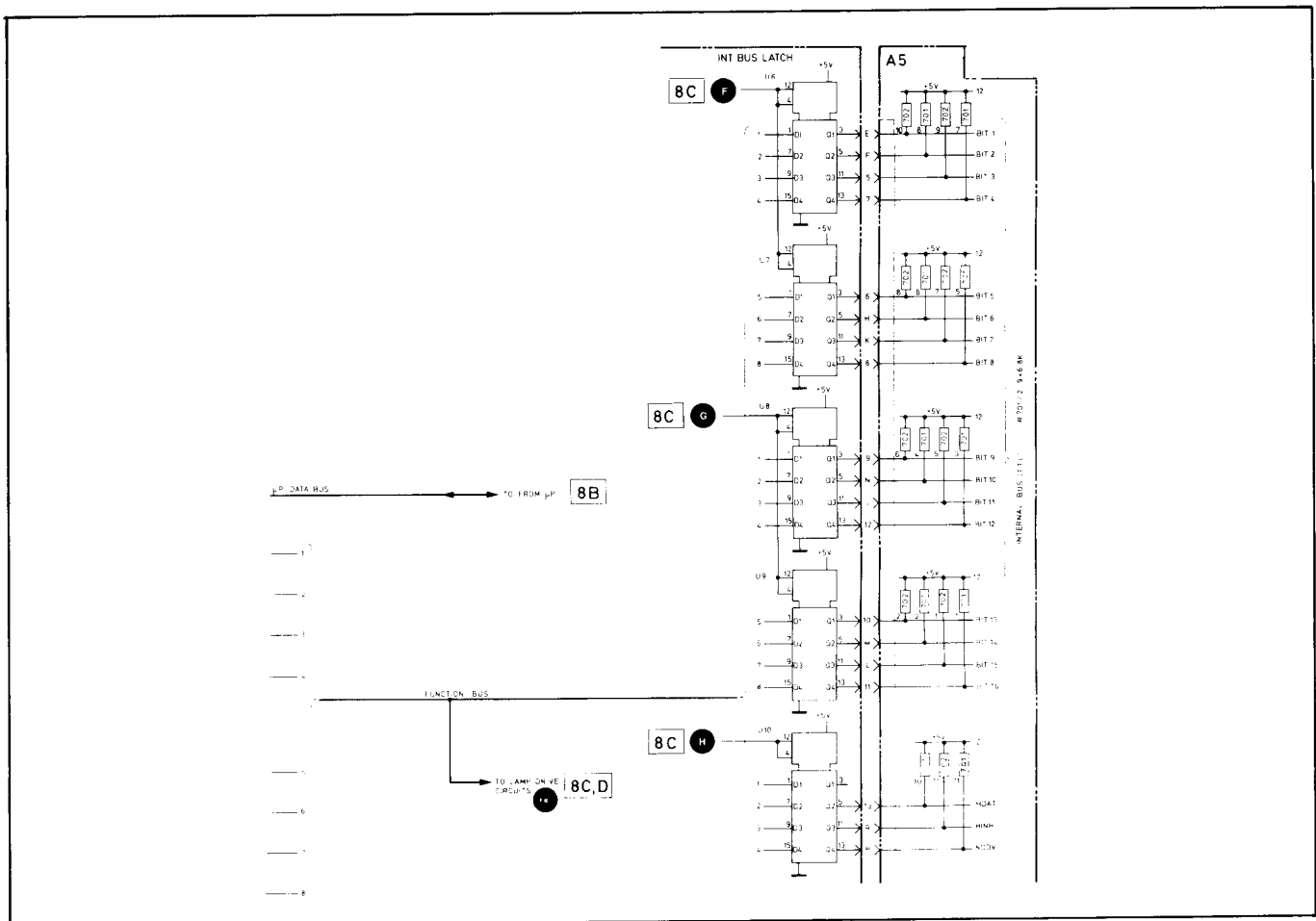

Figure 8-5-2. Control Line and Interface

Keyboard

The keyboard provides the interface between the user and the instrument during manual operation. Through the keyboard, the user can program the various operating parameters. Four vernier keys are also contained in the keyboard, to allow the user to alter numeric parameters.

The keys of the keyboard can be divided into eight groups plus a reset to local key which sets the 8165A back to local operation. The groups are as follows: INPUT MODE Group; the PARAMETER keys including STORE, RECALL; the FUNCTION keys; the DUTY CYCLE keys, the DATA keys, the ENTRY keys, the VERNIER keys, and last the OUTPUT MODE keys.

The keyboard scanner operates in the following manner. 7 bits are routed via the PIA U3 and fed to a Multiplexer and BCD-Decimal Decoder which form a key matrix. Pressing a key results in a low-going KEY DOWN Line. This line is routed over via PIA U3 and detected by the Microprocessor (software debouncing routine ensures the validity of the key-depress action).

Supervisory Signals

These signals include the two-phase clock signals (θ_1 and θ_2), Data Bus Enable (DBE) and Reset (\bar{R}). The two-phase clock signals and DBE are generated by the clock circuit. The clock signals drive the microprocessor and DBE enables the data bus. The start-up circuit provides the R line which initiates the start-up routine and resets the controller.

Restart and Battery Back-up Circuit (Schematic 8B)

The restart circuit provides the microprocessor with the required $\overline{\text{RESTART}}$ signal at power switch-on. This signal is a pulse with approximately 80 ms width and is fed to both the microprocessor and Peripheral Interface Adapter (PIA).

The battery back-up circuit provides battery charging during instrument power-on, and power to the non-volatile RAM section during instrument power-off. During instrument power-on, battery charging is done via the Q6 circuit (Schematic 8B). The resistor RT1, which has a negative temperature coefficient, disables the battery charge function at low temperatures ($< 0^\circ\text{C}$). In the instrument power-on state, the $+5_{\text{BATT}}$ voltage is derived from the +12 V via Q2. Diode CR1 then enables current flow to the RAMs, and diode CR2 turns Q7 off so that no battery discharge can occur.

When the power is switched off from the instrument, the battery voltage is connected via Q7 to the RAMs. Then diode CR1 prevent current flow over the +5 V line to other devices.

During normal operation, the RAMs require a high RAM ENABLE (CE2) signal. In the event of the $+5 V_{\text{BATT}}$ supply going down, the RAM ENABLE must go low prior to the $+5 V_{\text{BATT}}$ line falling below +4.75 V. This action ensures RAM data retention, and the RAM's then only require ± 2.5 V to supply the non-volatile section.

The RAM ENABLE signal is generated via Q5 and the differential amplifier Q3, Q4. During power switch-on, this signal (at TP4) also triggers the monostable flip-flop U48 to generate the RESET pulse.

TROUBLESHOOTING

Due to the service philosophy, troubleshooting is split into the following categories.

- A. Test of pre-conditions for correct microprocessor function.
- B. ROM test using SA.
- C. Display troubleshooting using SA and normal equipment.

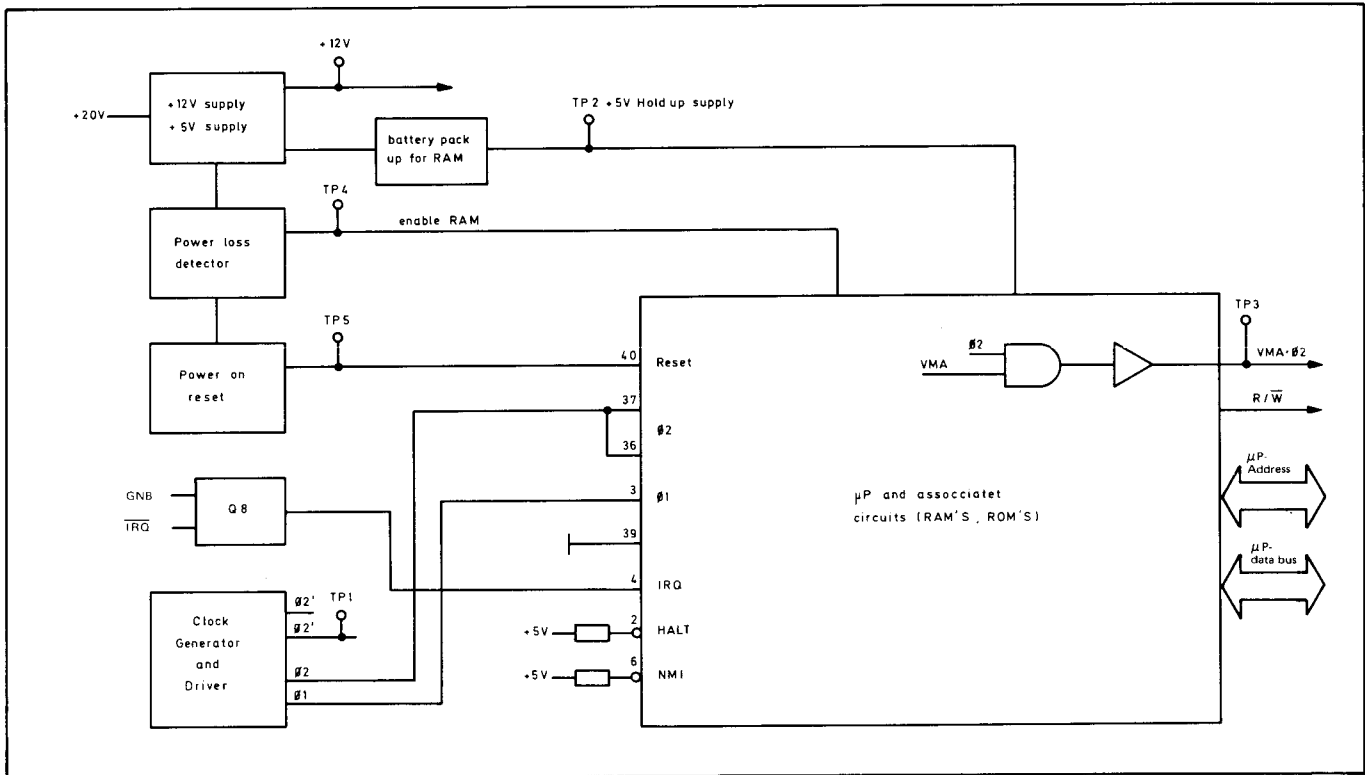

Figure 8-5-3. Microprocessor pre-conditions

A. Test of pre-conditions for correct μP function

- a. Set A3 on extender board and perform following tests:
- b. Using a DVM check following voltages on A3: +5 V, +20 V, -5 V, +.43 V, +12 V, TP3 +5 V Hold-up, TP4 High > +2.4 V.
- c. Using a DVM measure μP signal "BUS AVAILABLE" at U13 pin 7 which must be low < 0.4 V.
- d. To test if the μP runs complete cycles and all address/data bus lines are activated, apply an external pulse generator (TTL-Level), ≈ 1 Hz to TP4. Using a scope or logic probe, measure if all address/data lines are active.
- e. Trigger scope on neg. transition of TP5 signal (restart) and verify that there are no connections to GND and VDD from address- and data-bus.
- f. Measure with logic probe status of IRQ which must be high, (if not, disconnect ribbon cable to A14 HP-IB interface) and repeat test.
- g. Measure at U13 pin 5 (VMA) and TP3 (VMA ø2) with a logic probe. Both signals should be active.
- h. Measure at U13 pin 34 (R/W). Signal should be active.

- i. Using a two channel scope, connect both probes to A3 $\Phi 1$ and $\Phi 2$ signals, check clock's for conditions shown $\Phi 1$ and $\Phi 2$ must not be coincident. $\Phi 2$ has to be at the 10 % point of ampl. before $\Phi 1$ turns on.
- j. Using a scope, connect probe to A3 TP5 and measure the Power-on/Reset function by turning the instrument on/off.

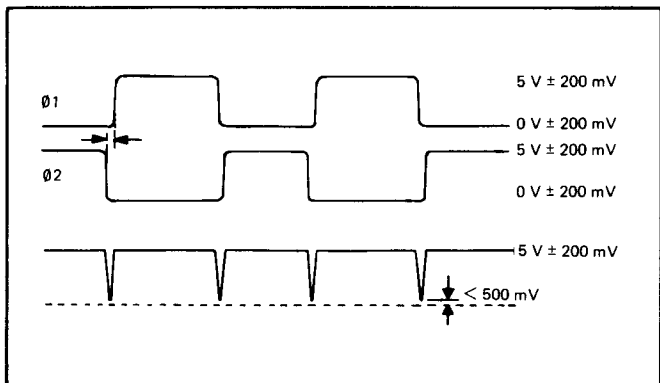

Figure 8-5-4. μP clock

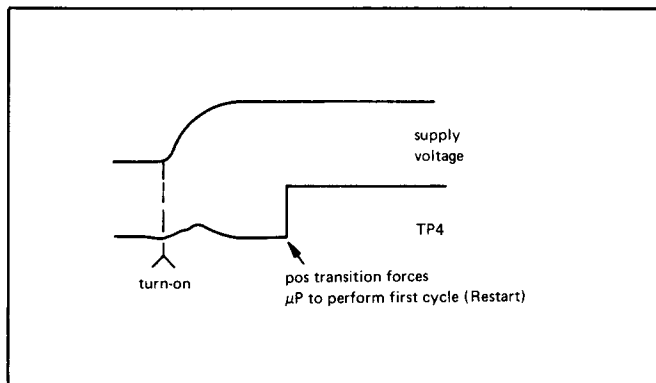

Figure 8-5-5. Power on/re-start

B. ROM Test using Signature Analysis

Equipment required:

5004A Signature Analyzer

Extender board 5061-2112 (for μP)

Procedure:

Set A3 on extender board. Follow instructions as shown. The test is done in μP -free run mode and normal scan routine. In order to use extender board 5061-2112, remove μP U13, plug in extender board, and plug U13 into the extender board.

Test sequence:

- a. Address Bus Test
- b. Address Decoder Test
- c. ROM and Data Bus Test
- d. Display Troubleshooting

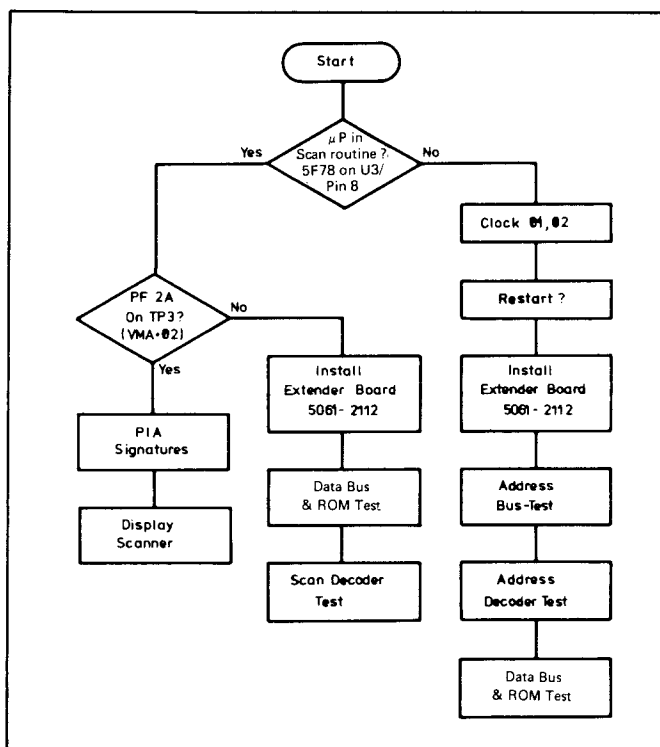





Figure 8-5-6. Flow chart

a. Address Bus Test (free run routine)

Signature Analyzer settings:

- CLOCK  to TP 02
- START  to A15
- STOP  to A15
- HI-SA 0003

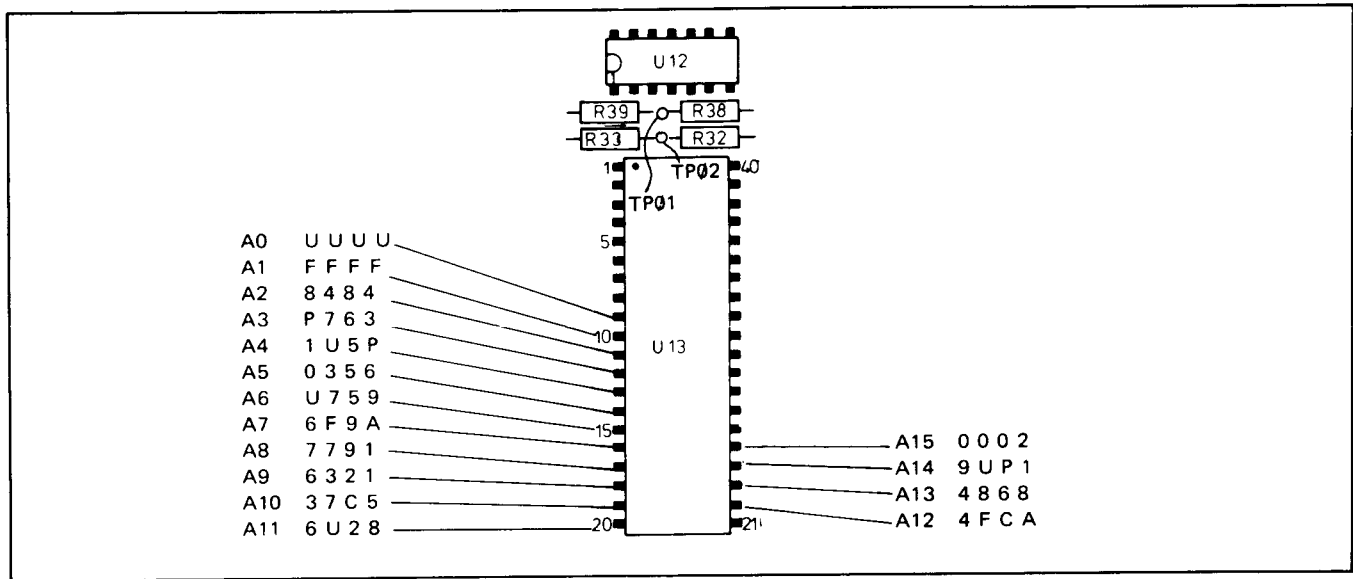

Figure 8-5-7. Address bus signatures

b. Address Decoder Test (same settings as previous test)

Table 8-5-1. Address decoder signatures

U15 pin	4	7 5 5 H
	7	P A C H
	9	0 0 0 3
	10	H 7 8 5
	11	0 0 0 3
	12	3 H 3 C
U16	6	7 7 9 2
U17	4	7 7 9 1
	5	7 5 5 H
	6	0 U 5 7
	11	7 A 0 9

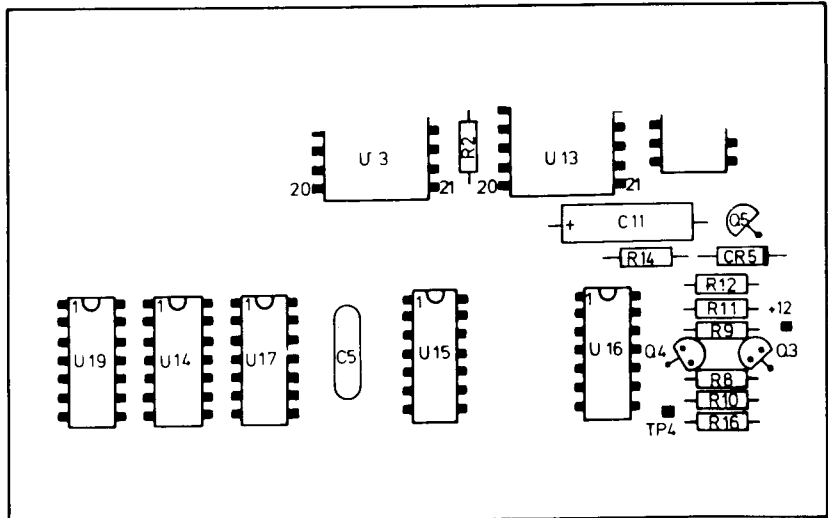
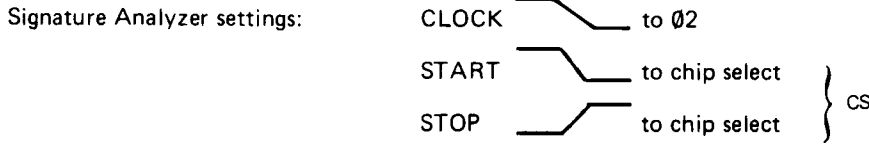

Figure 8-5-8. Address decoder IC's

c. ROM and Data Bus Test



RAM U20 contains the information of all stored data (0 – 9)

Table 8–5–2. ROM and data bus signatures

	pin	U24	U25
D0	9	0 9 9 5	U 1 P 5
D1	10	2 3 7 C	I 3 3 P
D2	11	U 3 U A	3 C 8 3
D3	13	F 9 7 I	U 4 A F
D4	14	9 7 A 6	3 G P I
D5	15	C P F A	U 0 C F
D6	16	H 0 8 8	9 P U H
D7	17	2 P A C	5 9 6 6

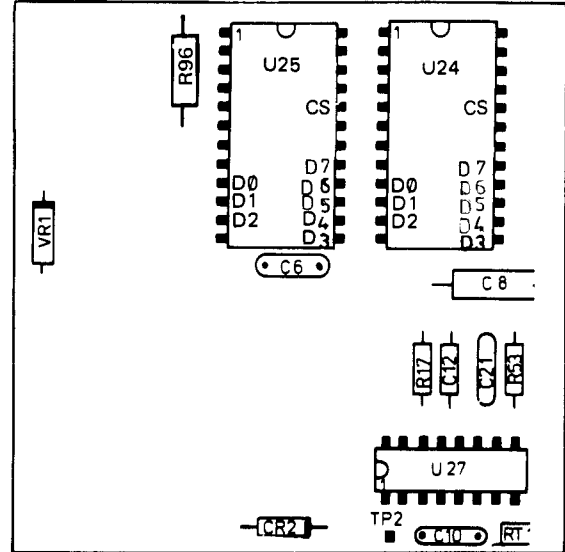

Figure 8–5–9. Data bus IC's

d. Display Troubleshooting

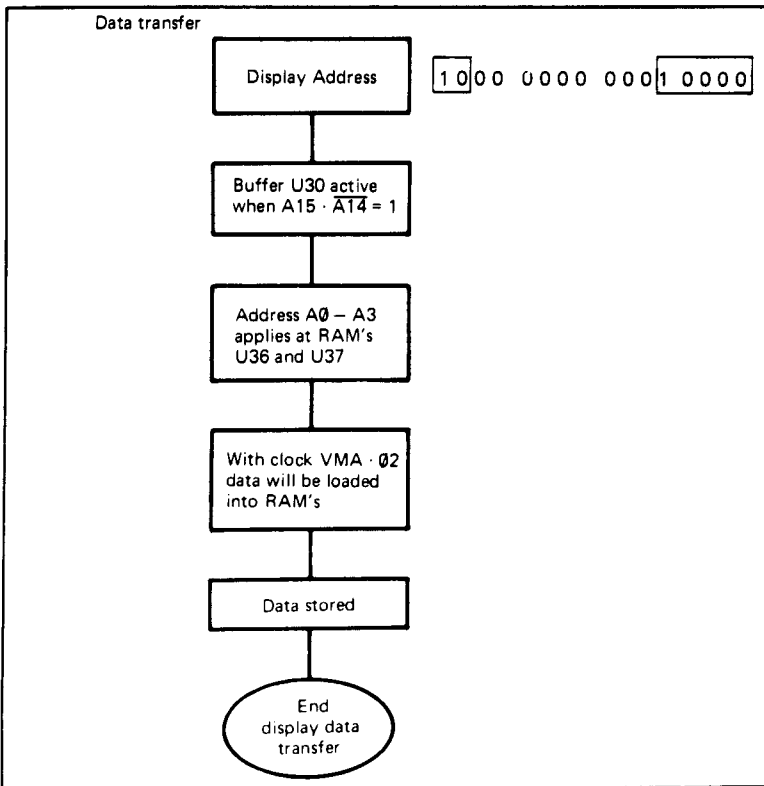

Figure 8–5–10. Display flowchart

Signature Analyzer settings:

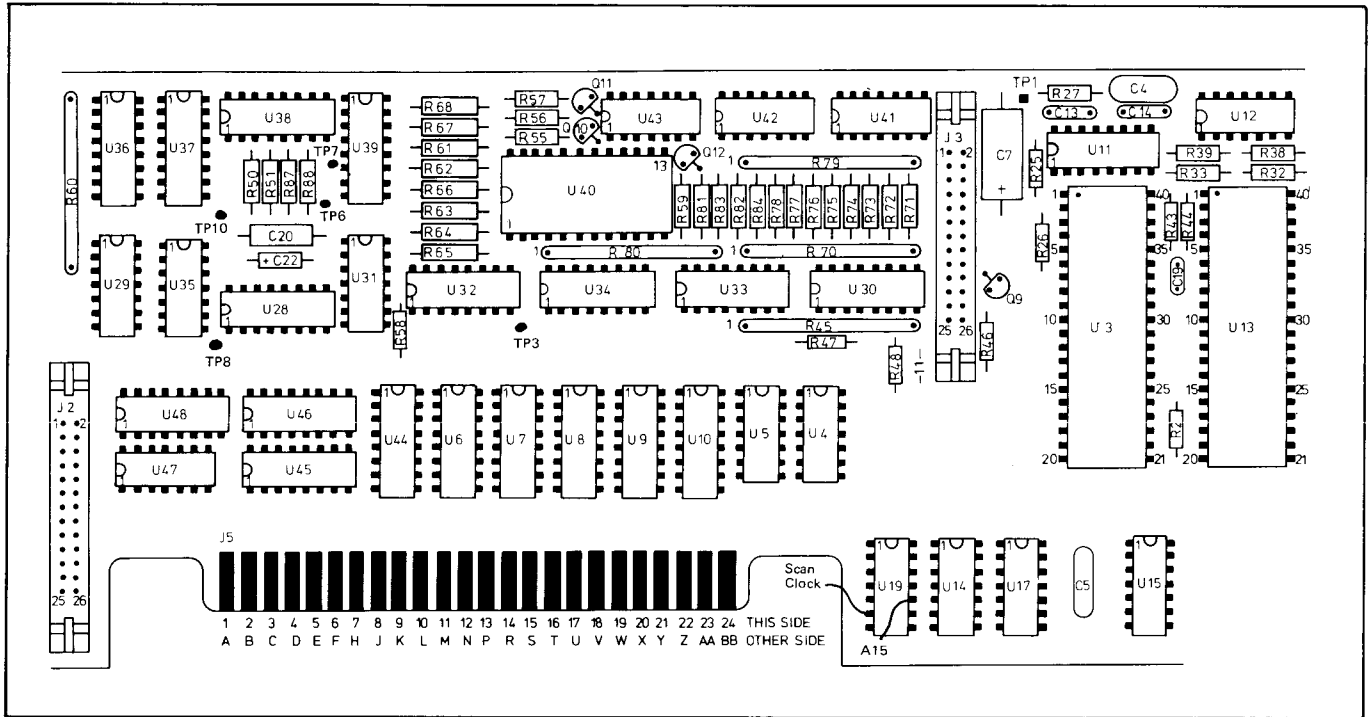
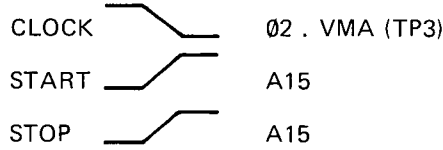

Figure 8-5-11. Section of Microprocessor Board A3

Table 8-5-3. Display signatures

U19 pin 9	9 U P 2	U31 pin 1	4 H 4 0
8	P A C U	4	O F F 7
U30 pin 3	2 2 3 3	6	3 9 9 9
5	7 H 6 9	U47 pin 11	O F F 4
7	I F A 3	U35 pin 6	4 H 4 3
9	3 9 9 A	U34 pin 2	H 1 H 4
13	4 1 8 4	6	C 4 7 5
U33 pin 1	H 1 H 7	4	2 H 1 H
2	C 4 7 6	12	F C 4 7
3	2 H 1 P	15	3 2 H 1
4	F C 4 4		
5	3 2 H 2		

e. Display RAM output test

PROCEDURE: re-install microprocessor IC U3

Set Signature Analyzer:

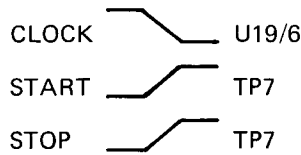

Set 8165A as follows:

- AM OFF
- Input Mode NORM
- Function TRIANGLE
- Duty Cycle 50 %
- FM OFF
- Frequency 23.45 kHz
- Amplitude 1.00 V
- Offset 0 V
- Burst 5
- Output Mode NORM, 50 Ω, ENABLED
- Sweep Start 1 kHz
- Sweep Stop 10 kHz
- Sweep Time 1 s

Table 8-5-4. Display RAM signatures

U36 pin 5	0	P	4	4	U37 pin 7	0	0	1	0
	7	0	P	H	5	5	0	0	0
	9	0	P	2	4				
	11	0	P	1	4				

f. Display decoder and driver troubleshooting

By using the LAMP TEST (TP9 to GND) all LED's and display's must be on. The Error lamp must blink.

The BLANK signal is only generated when the scan-generator fails.

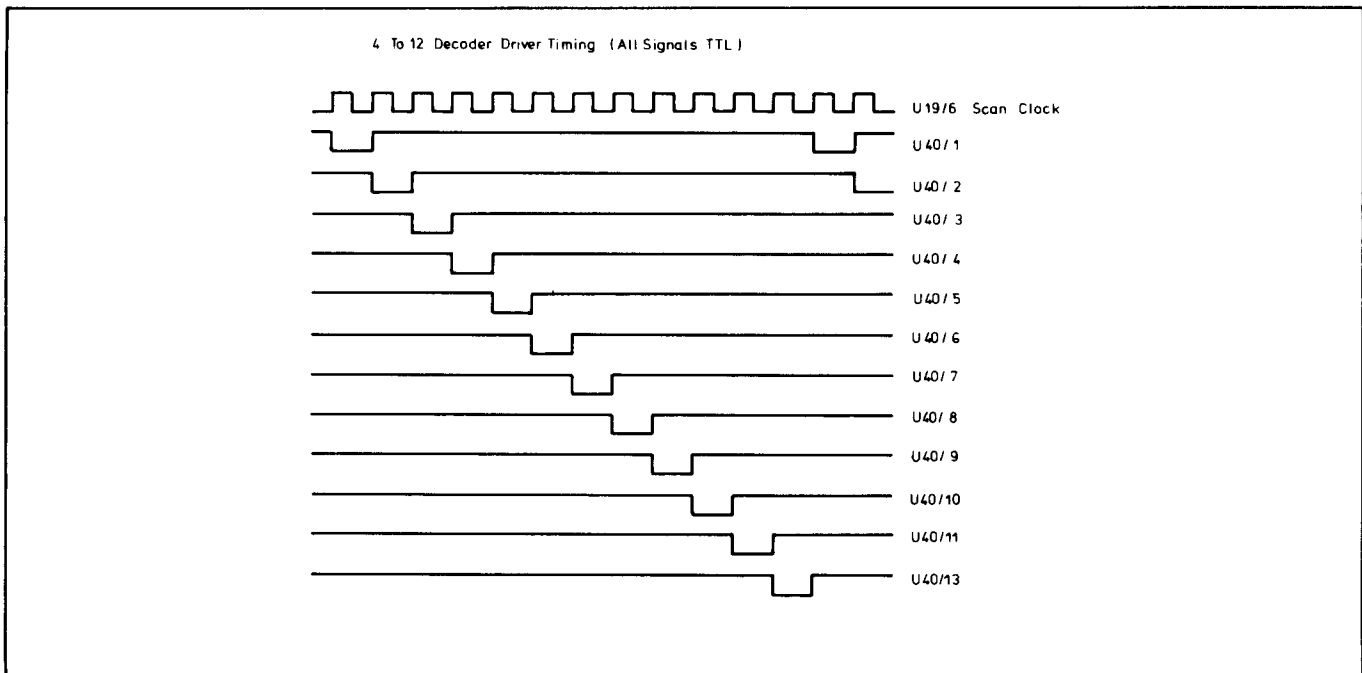

Figure 8-5-12. U40 timing in NORM operation

g. Keyboard scanner bus troubleshooting

By using a normal scope measure following signals:

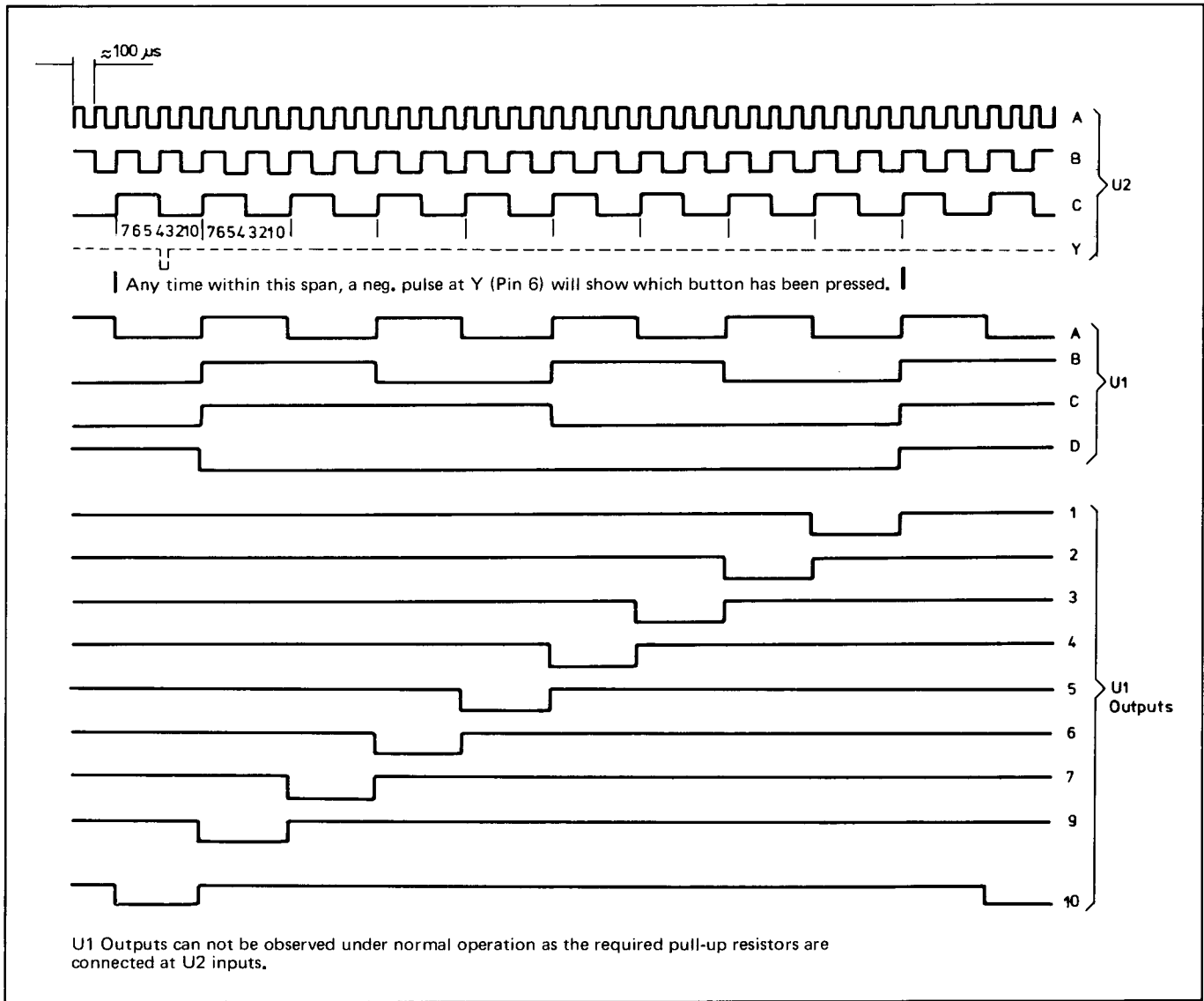
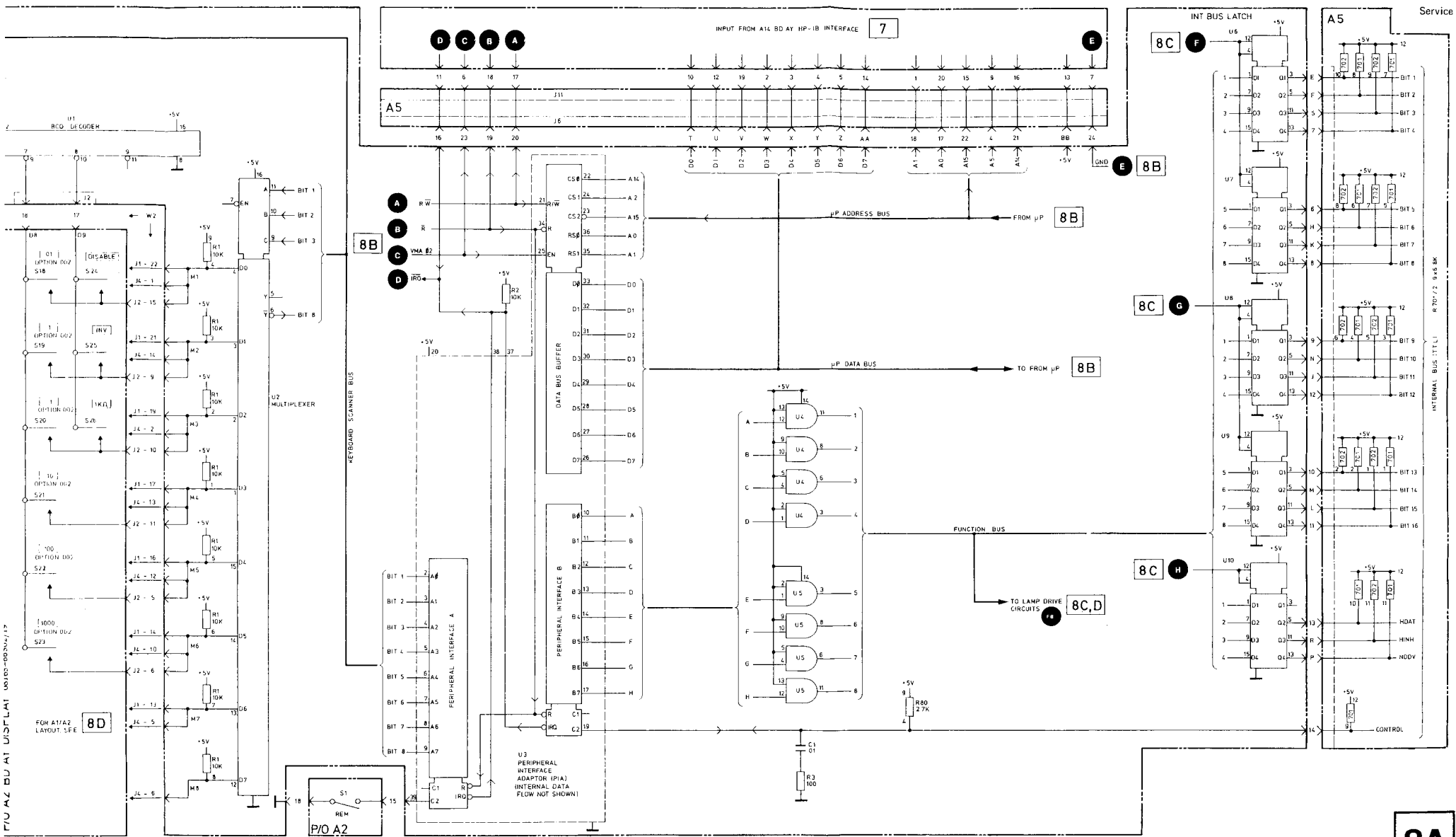

Figure 8-5-13. Keyboard Scanner Timing Cycle



A1, A2, A3, A5
MICROPROCESSOR I/O

8A

P/O A3 BD AY PROCESSOR 08165-66523

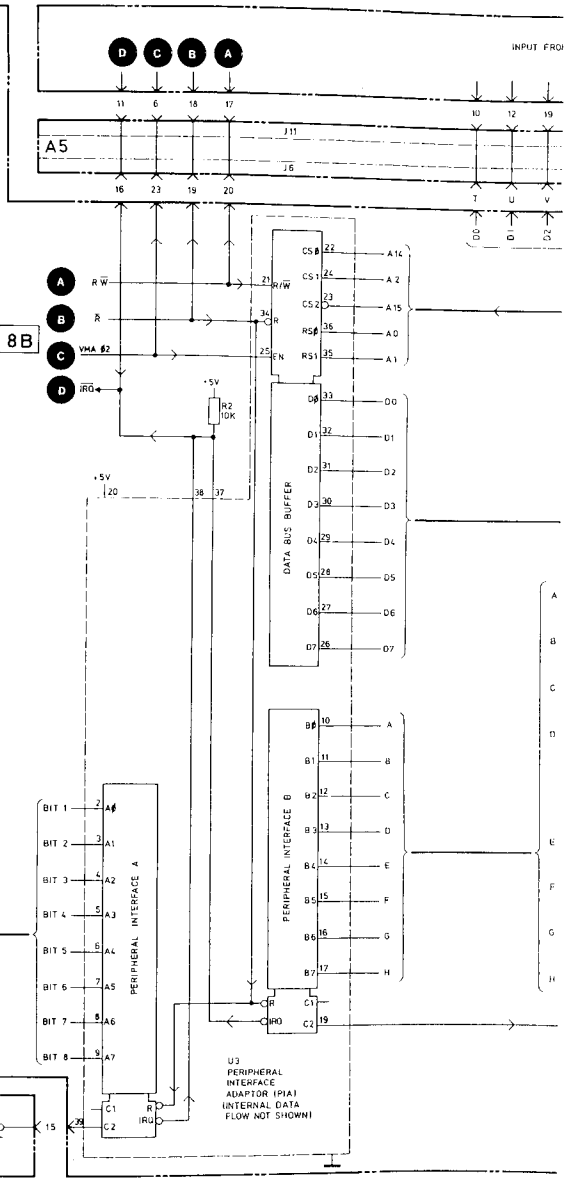
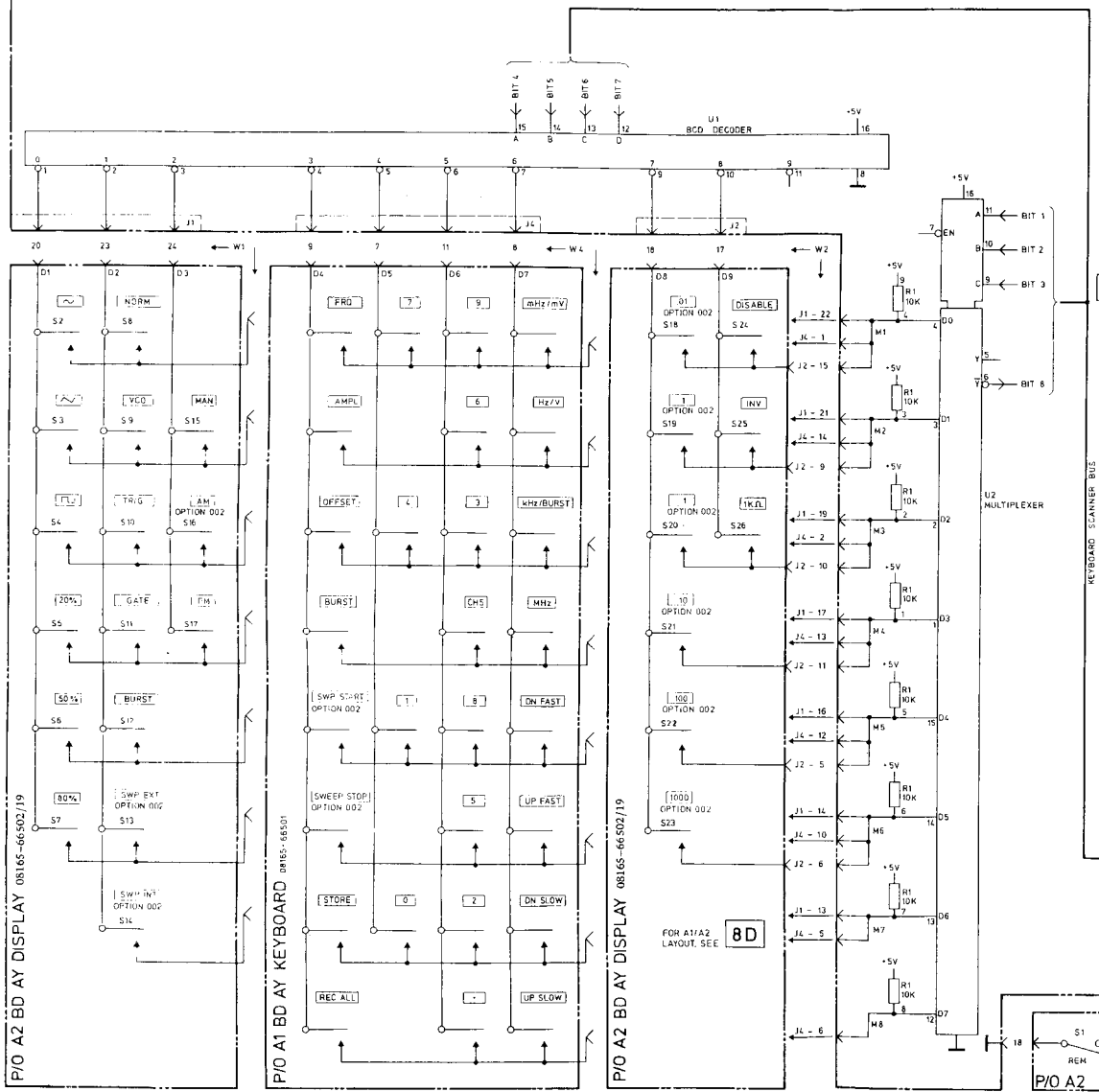

AY PROCESSOR 08165 44523

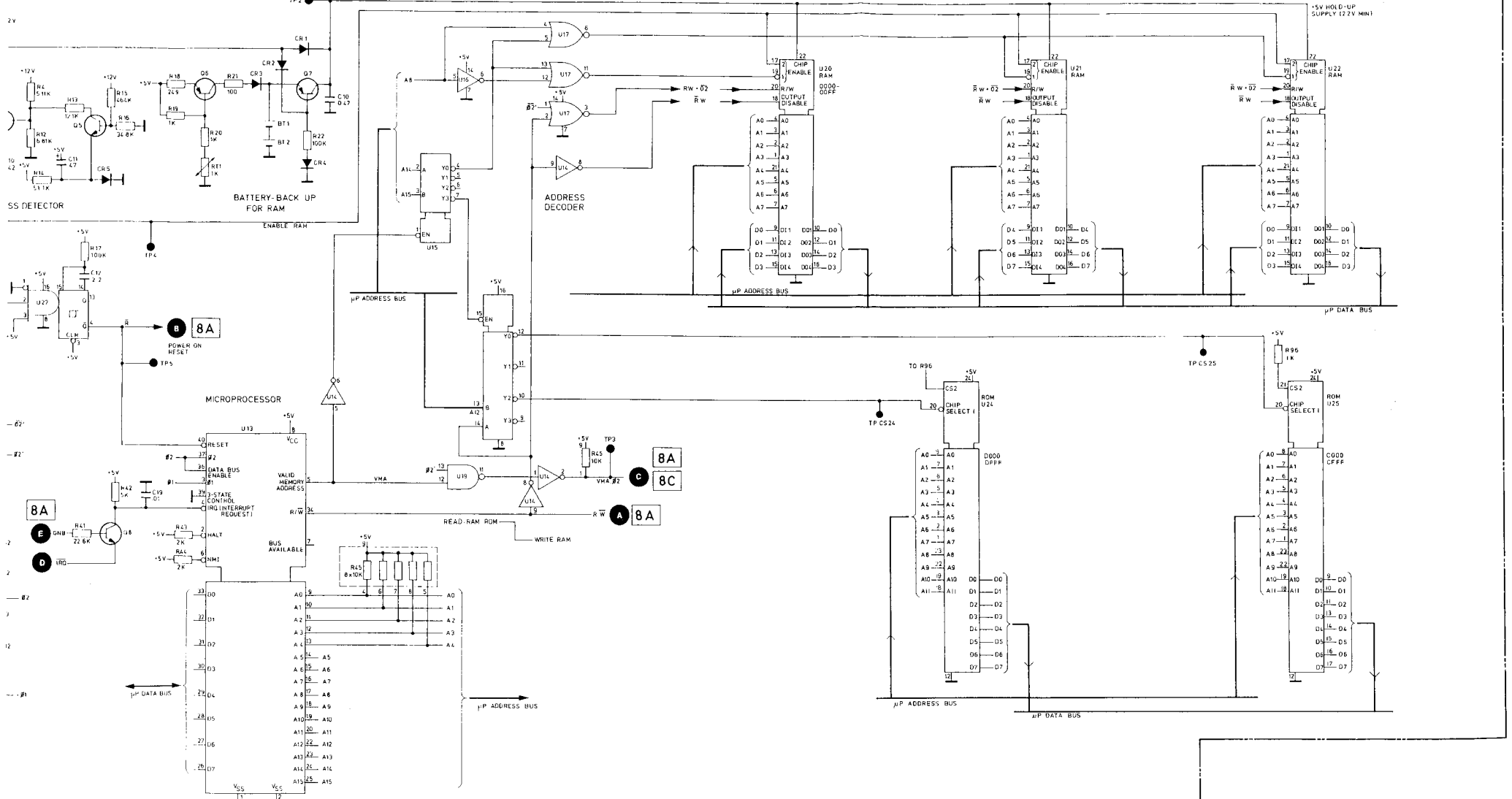

A3 MICROPROCESSOR AND MEMORY

8B

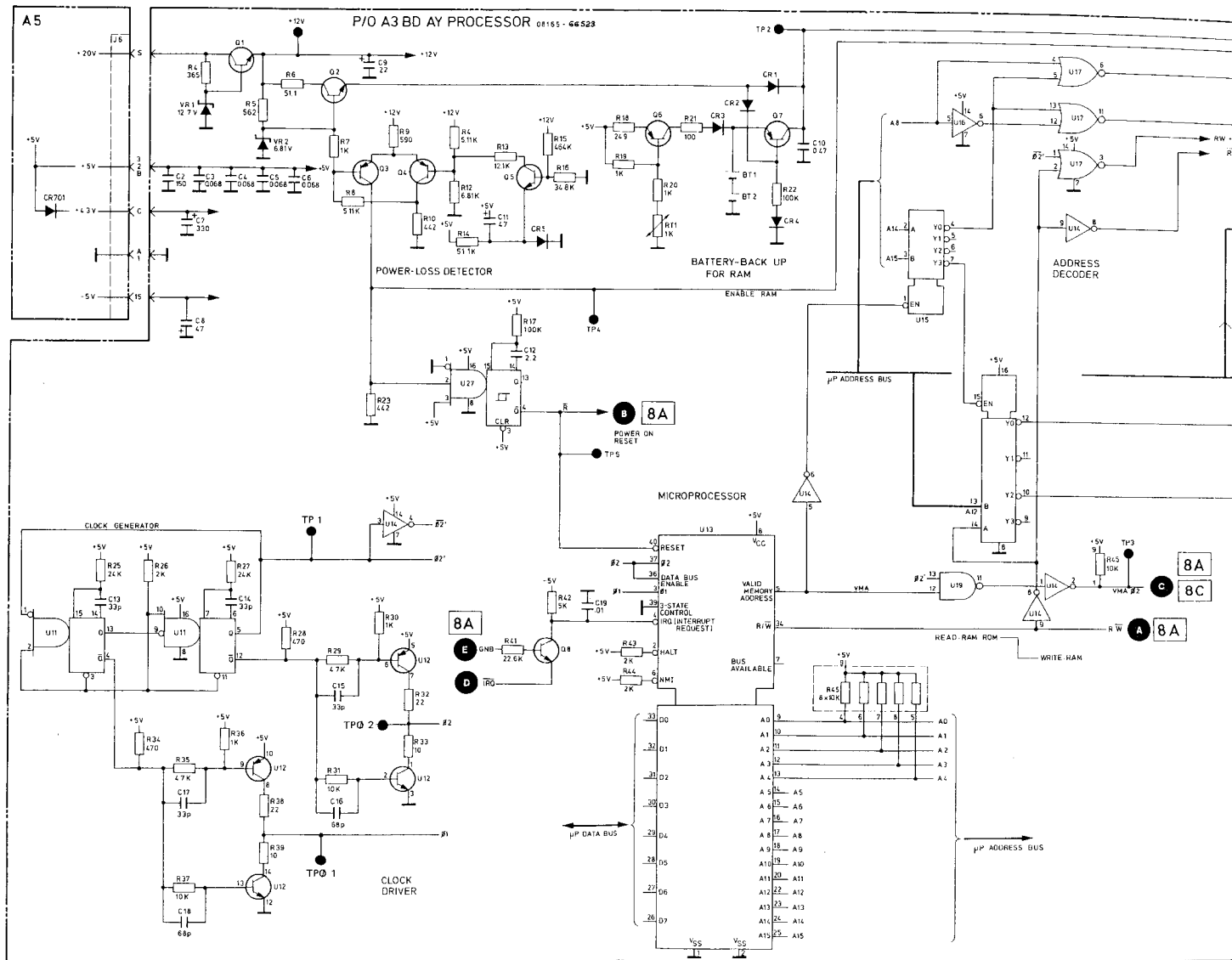

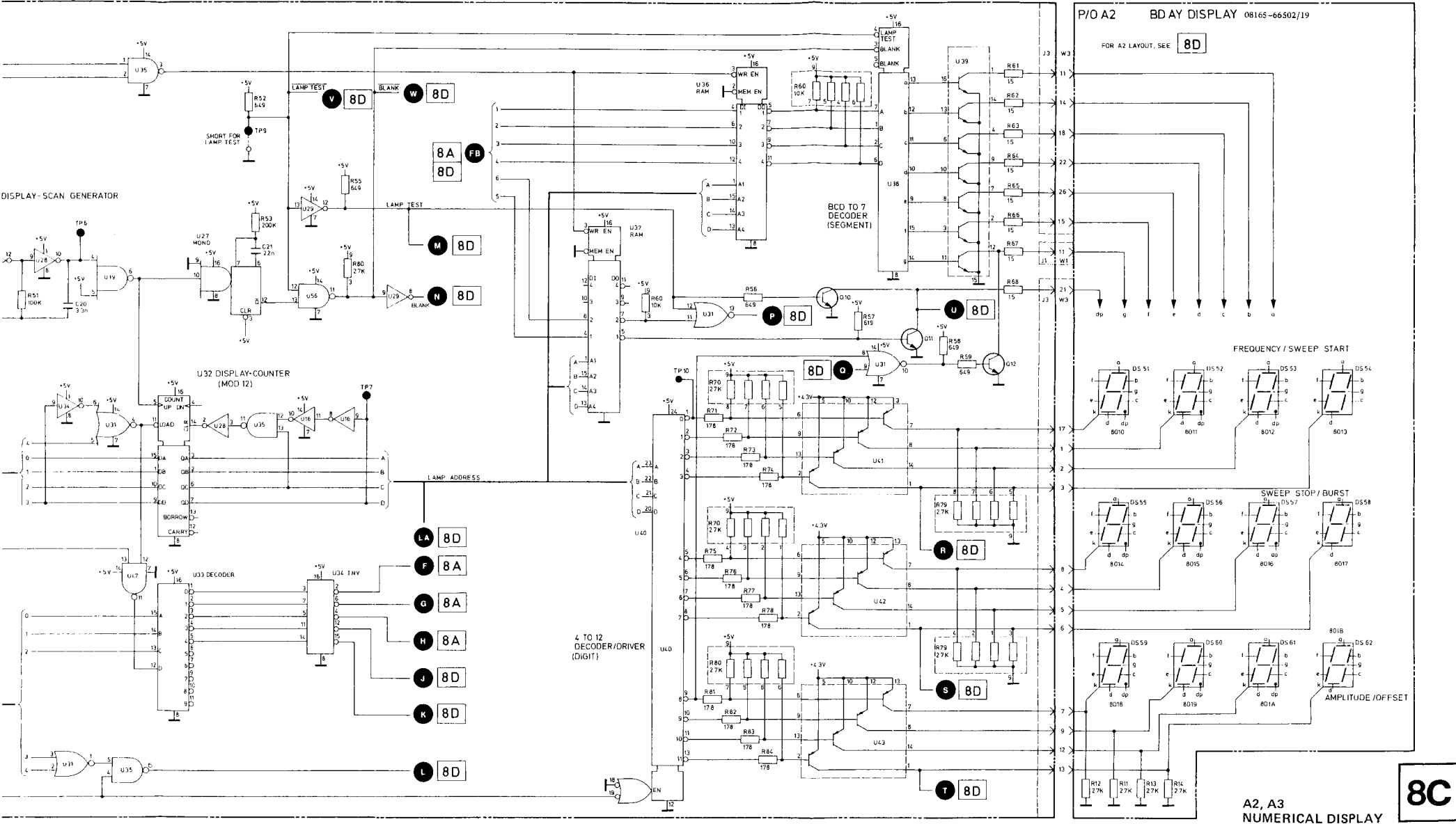

A2, A3
NUMERICAL DISPLAY

8C

P/O A3 BD AY PROCESSOR 08165 - 66523

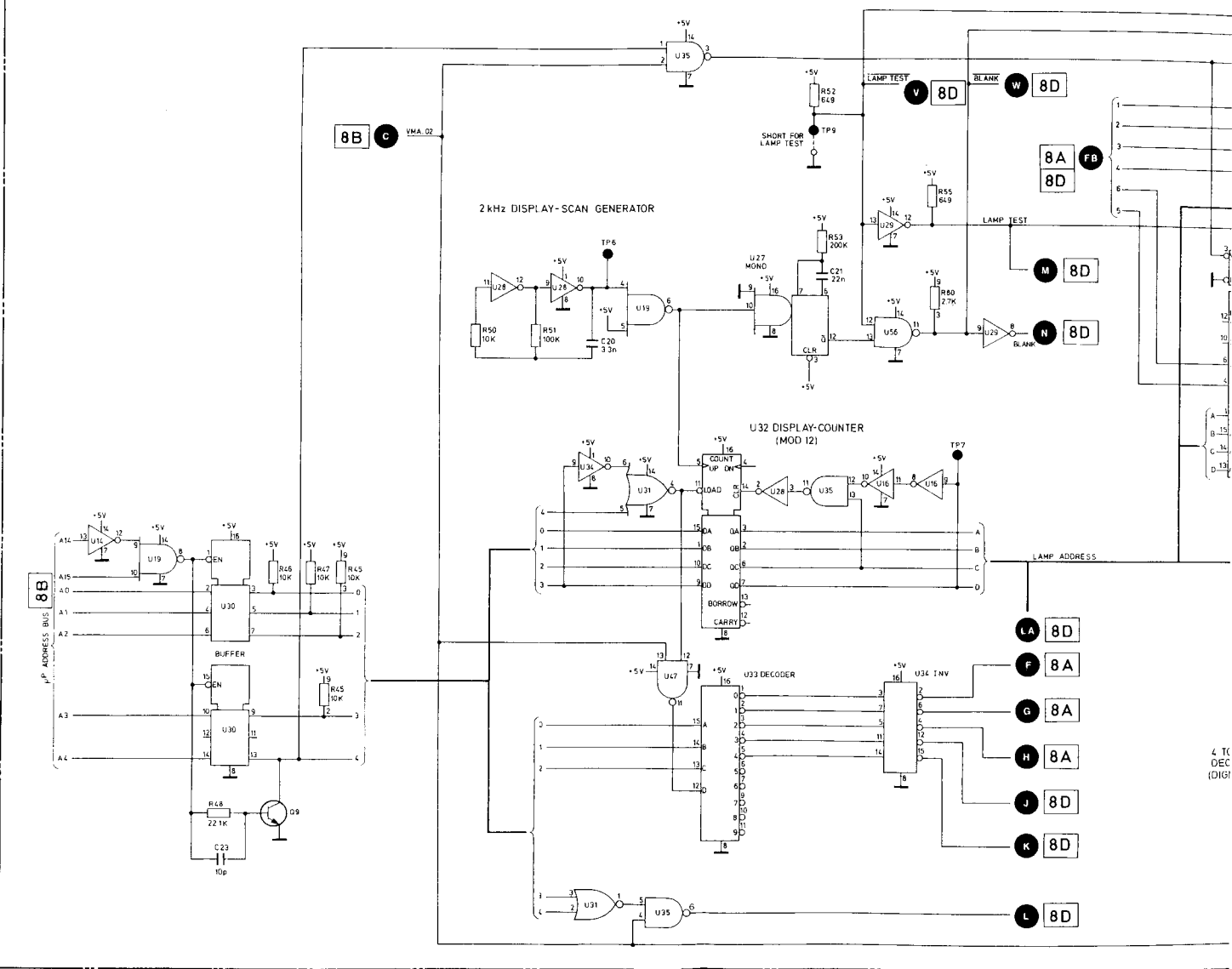

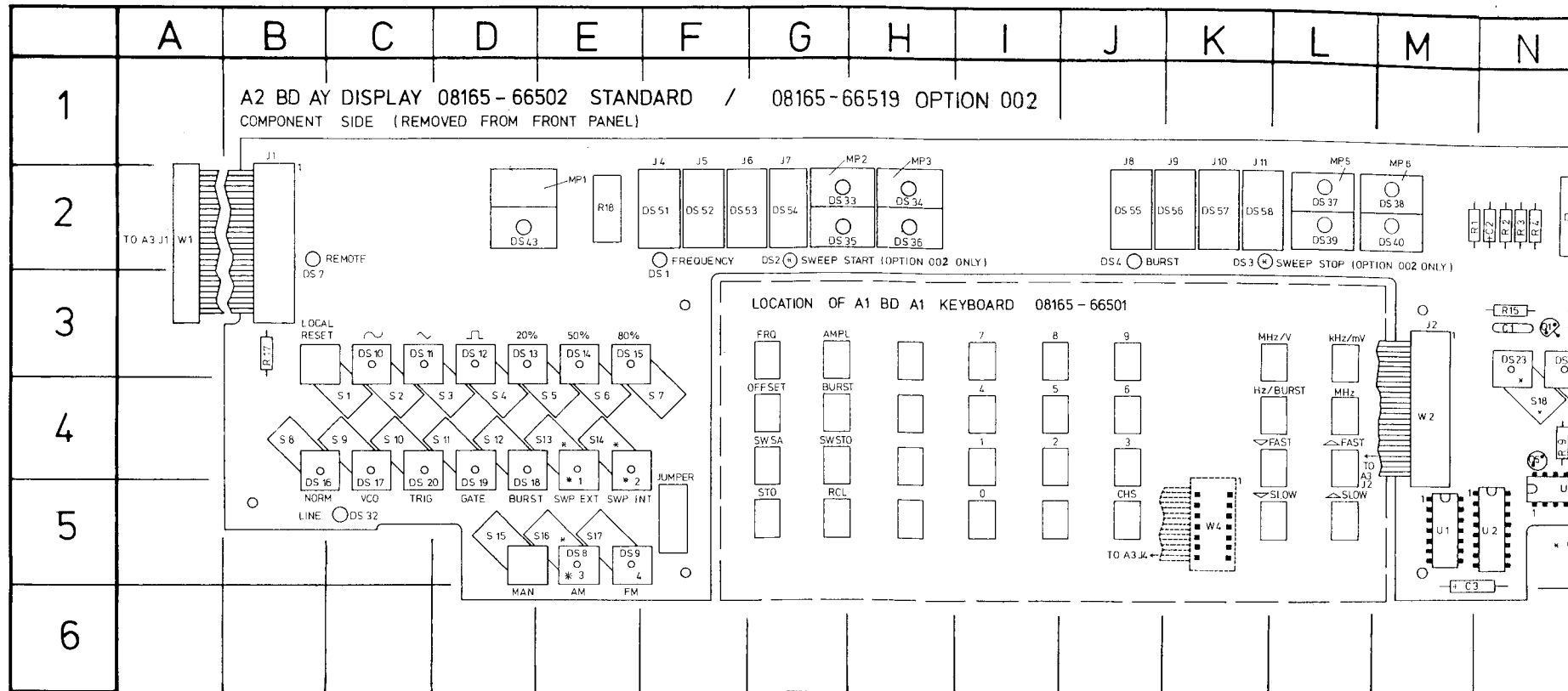

REF DESIG	GRID LOC	REF DESIG	GRID LOC	REF DESIG	GRID LOC	REF DESIG	GRID LOC	REF DESIG	GRID LOC	REF DESIG	GRID LOC	REF DESIG	GRID LOC	REF DESIG	GRID LOC
C1	N3	DS12	D3	DS27	P3	DS42	P2	J2	M3	MP2	G2	R4	N2	S2	C4
C2	N2	DS13	D3	DS28	P3	DS43	D2	J3	Q2	MP3	H2	R5	O3	S3	D4
C3	N6	DS14	E3	DS29	D4	DS51	F2	J4	F2	MP4	P2	R6	O3	S4	D4
C4	O4	DS15	E3	DS30	P4	DS52	F2	J5	F2	MP5	L1	R7	P3	S5	E4
		DS16	B4	DS31	P4	DS53	F2	J6	F2	MP6	M1	R8	P3	S6	E4
DS1	F2	DS17	C4	DS32	C6	DS54	G2	J7	G2	Q1	N3	R9	N4	S7	F4
DS2	G2	DS18	D4	DS33	G2	DS55	J2	J8	J2	Q1	N3	R10	O4	S8	B4
DS3	L2	DS19	D4	DS34	H2	DS56	K2	J9	K2	Q2	O3	R11	O3	S9	C4
DS4	J2	DS20	C4	DS35	G2	DS57	K2	J10	K2	Q3	O3	R12	O3	S10	C4
DS5	O2	DS21	E4	DS36	H2	DS58	K2	J11	K2	Q4	P3	R13	O3	S11	D4
DS6	P2	DS22	E4	DS37	L2	DS59	O2	J12	O1	O5	N4	R14	O4	S12	D4
DS7	B2	DS23	N3	DS38	M2	DS60	O2	J13	O1	O6	O4	R15	N3	S13	E4
DS8	B6	DS24	N3	DS39	L2	DS61	O2	J14	O1	R1	N2	R16	O4	S14	E4
DS9	B6	DS24	N3	DS39	L2	DS61	O2	J14	O1	R2	N2	R17	B3	S15	D5
DS10	C3	DS25	O3	DS40	M2	DS62	P2	J15	P1	R3	N2	S1	C4	S16	E5
DS11	C/D3	DS26	O3	DS41	P2	J1	B2	MP1	D2						

8D

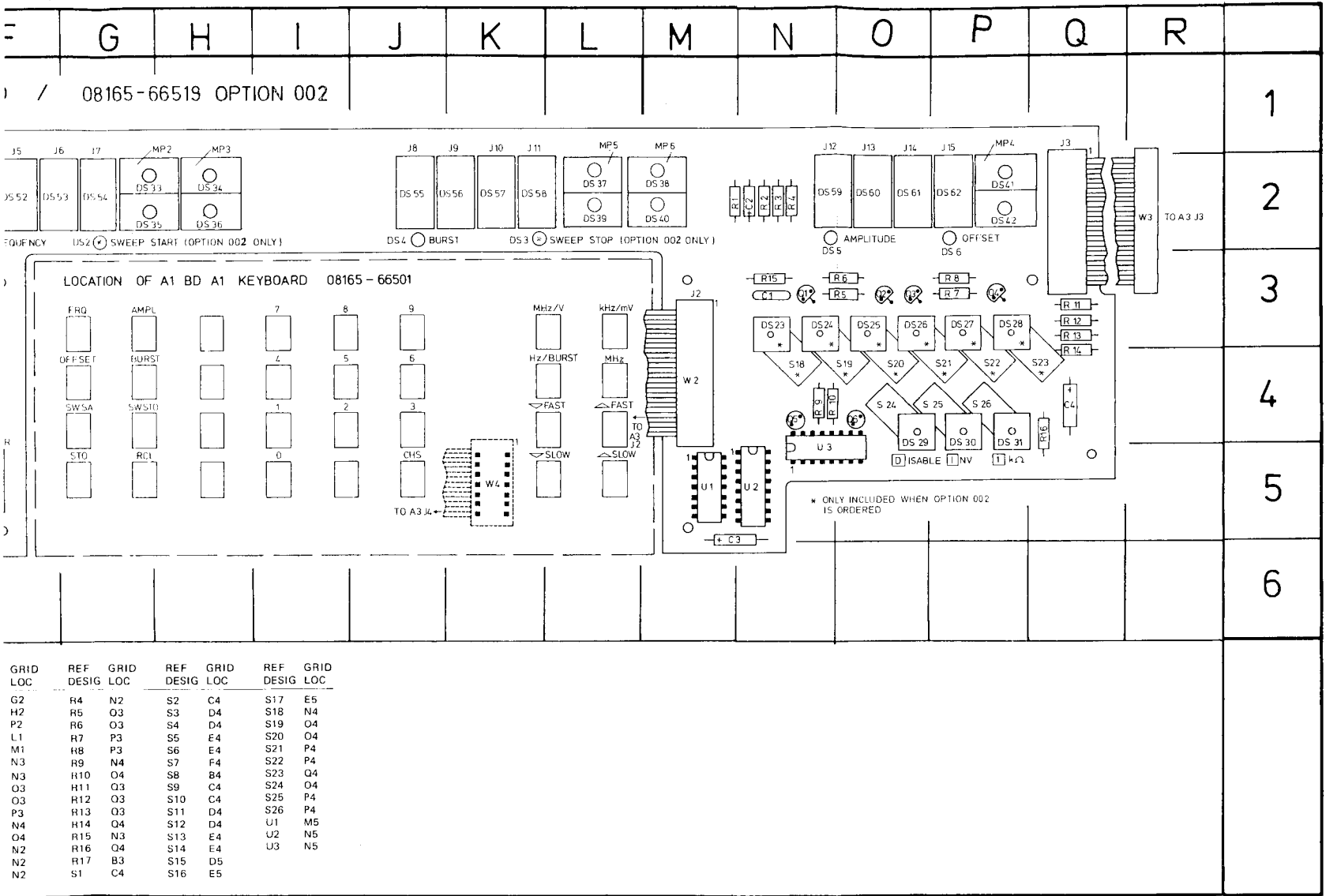

GRID LOC	REF DESIG	GRID LOC	REF DESIG	GRID LOC	REF DESIG	GRID LOC
G2	R4	N2	S2	C4	S17	E5
H2	R5	O3	S3	D4	S18	N4
P2	R6	O3	S4	D4	S19	O4
L1	R7	P3	S5	E4	S20	O4
M1	R8	P3	S6	E4	S21	P4
N3	R9	N4	S7	F4	S22	P4
N3	R10	O4	S8	B4	S23	O4
O3	R11	O3	S9	C4	S24	O4
O3	R12	O3	S10	C4	S25	P4
P3	R13	O3	S11	D4	S26	P4
N4	R14	O4	S12	D4	U1	M5
O4	R15	N3	S13	E4	U2	N5
N2	R16	O4	S14	E4	U3	N5
N2	R17	B3	S15	D5		
N2	S1	C4	S16	E5		

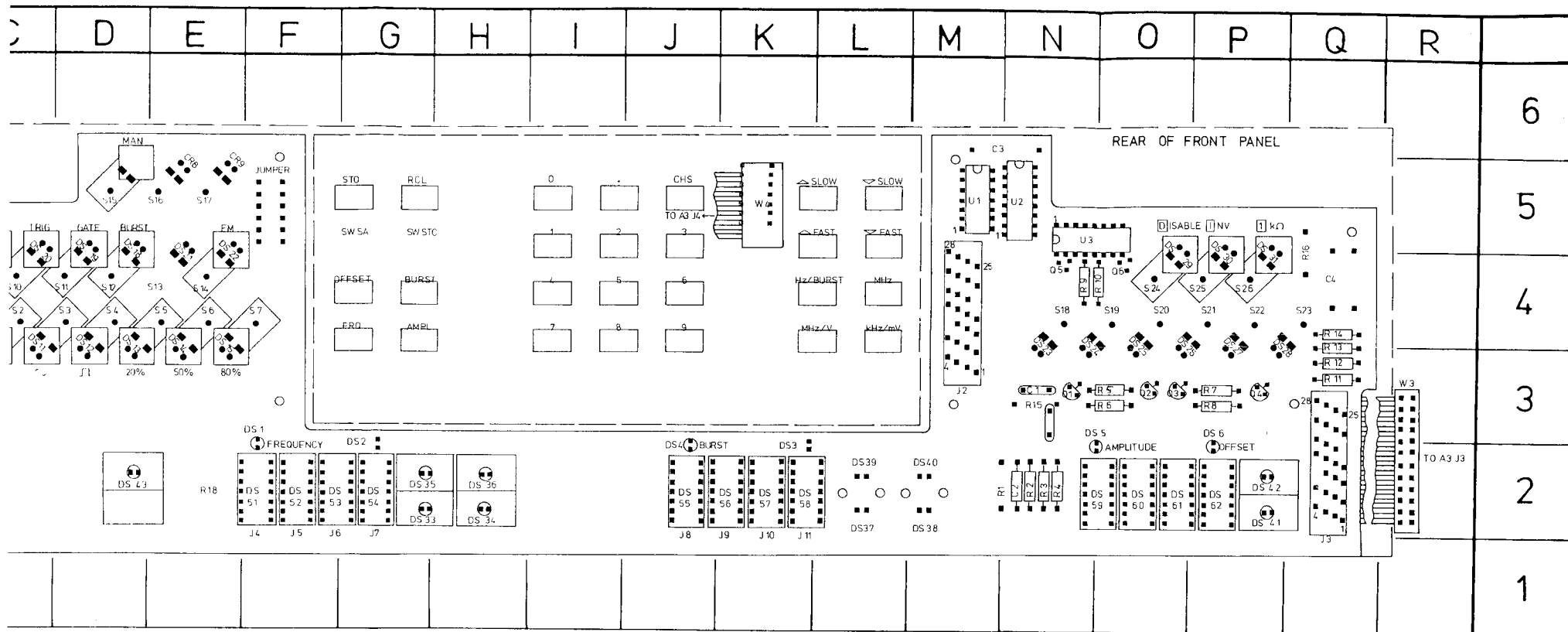

GRID LOC	REF DESIG	GRID LOC	REF DESIG	GRID LOC	REF DESIG	GRID LOC	REF DESIG	GRID LOC	REF DESIG	GRID LOC
3	DS42	P2	J2	M3	MP2	G2	R4	N2	S2	C4
3	DS43	D2	J3	O2	MP3	H2	R5	O3	S3	D4
4	DS51	F2	J4	F2	MP4	P2	R6	O3	S4	O4
4	DS52	F2	J5	F2	MP5	L1	R7	P3	S5	E4
4	DS53	F2	J6	F2	MP6	M1	R8	P3	S6	E4
5	DS54	G2	J7	G2	Q1	N3	R9	N4	S7	F4
2	DS55	J2	J8	J2	Q1	N3	R10	O4	S8	B4
2	DS56	K2	J9	K2	Q2	O3	R11	O3	S9	C4
2	DS57	K2	J10	K2	Q3	O3	R12	O3	S10	C4
2	DS58	K2	J11	K2	Q4	P3	R13	O3	S11	D4
2	DS59	O2	J12	O1	Q5	N4	R14	O4	S12	O4
2	DS60	O2	J13	O1	Q6	O4	R15	N3	S13	E4
2	DS61	O2	J14	O1	R1	N2	R16	O4	S14	E4
2	DS62	P2	J15	P1	R2	N2	R17	B3	S15	D5
2	J1	B2	MP1	D2	R3	N2	S1	C4	S16	E5

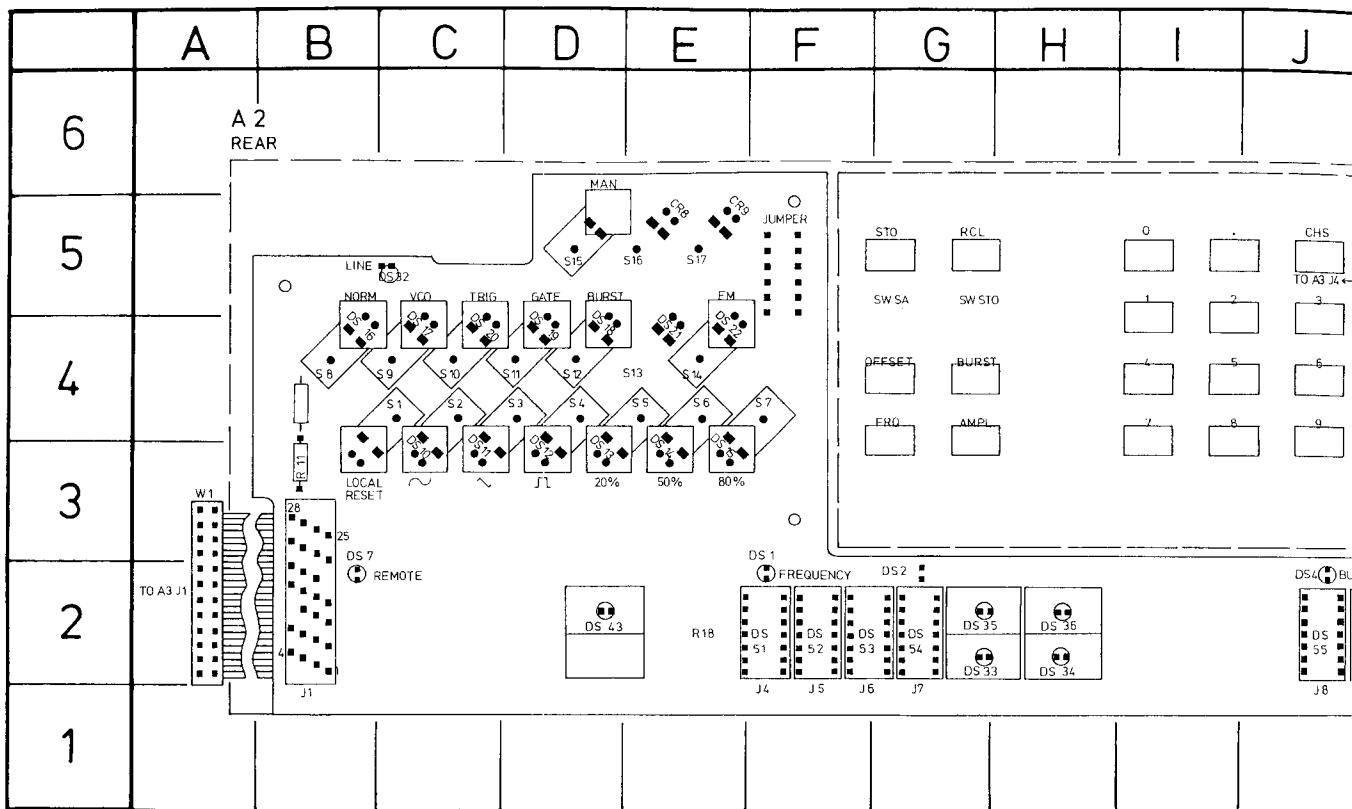

REF DESIG	GRID LOC	REF DESIG	GRID LOC	REF DESIG	GRID LOC	REF DESIG	GRID LOC	REF DESIG	GRID LOC	REF DESIG	GRID LOC	REF DESIG	GRID LOC	REF DESIG	GRID LOC
C1	N3	DS12	D3	DS27	P3	DS42	P2	J2	M3	MP2	G2	R4	N2	S2	C4
C2	N2	DS13	D3	DS28	P3	DS43	D2	J3	Q2	MP3	H2	R5	O3	S3	D4
C3	N6	DS14	E3	DS29	D4	DS51	F2	J4	F2	MP4	P2	R6	O3	S4	D4
C4	O4	DS15	E3	DS30	P4	DS52	F2	J5	F2	MP5	L1	R7	P3	S5	E4
		DS16	B4	DS31	P4	DS53	F2	J6	F2	MP6	M1	R8	P3	S6	E4
DS1	F2	DS17	C4	DS32	C5	DS54	G2	J7	G2	Q1	N3	R9	N4	S7	F4
DS2	G2	DS18	D4	DS33	G2	DS55	J2	J8	J2	Q1	N3	R10	O4	S8	B4
DS3	L2	DS19	D4	DS34	H2	DS56	K2	J9	K2	Q2	O3	R11	O3	S9	C4
DS4	J2	DS20	C4	DS35	G2	DS57	K2	J10	K2	Q3	O3	R12	O3	S10	C4
DS5	O2	DS21	E4	DS36	H2	DS58	K2	J11	K2	Q4	P3	R13	O3	S11	D4
DS6	P2	DS22	E4	DS37	L2	DS59	O2	J12	O1	Q5	N4	R14	O4	S12	D4
DS7	B2	DS23	N3	DS38	M2	DS60	O2	J13	O1	Q6	O4	R15	N3	S13	E4
DS9	B6	DS24	N3	DS39	L2	DS61	O2	J14	O1	R1	N2	R16	O4	S14	E4
DS10	C3	DS25	O3	DS40	M2	DS62	P2	J15	P1	R2	N2	R17	B3	S15	D5
DS11	C/D3	DS26	O3	DS41	P2	J1	B2	MP1	D2	R3	N2	S1	C4	S16	E5

8D

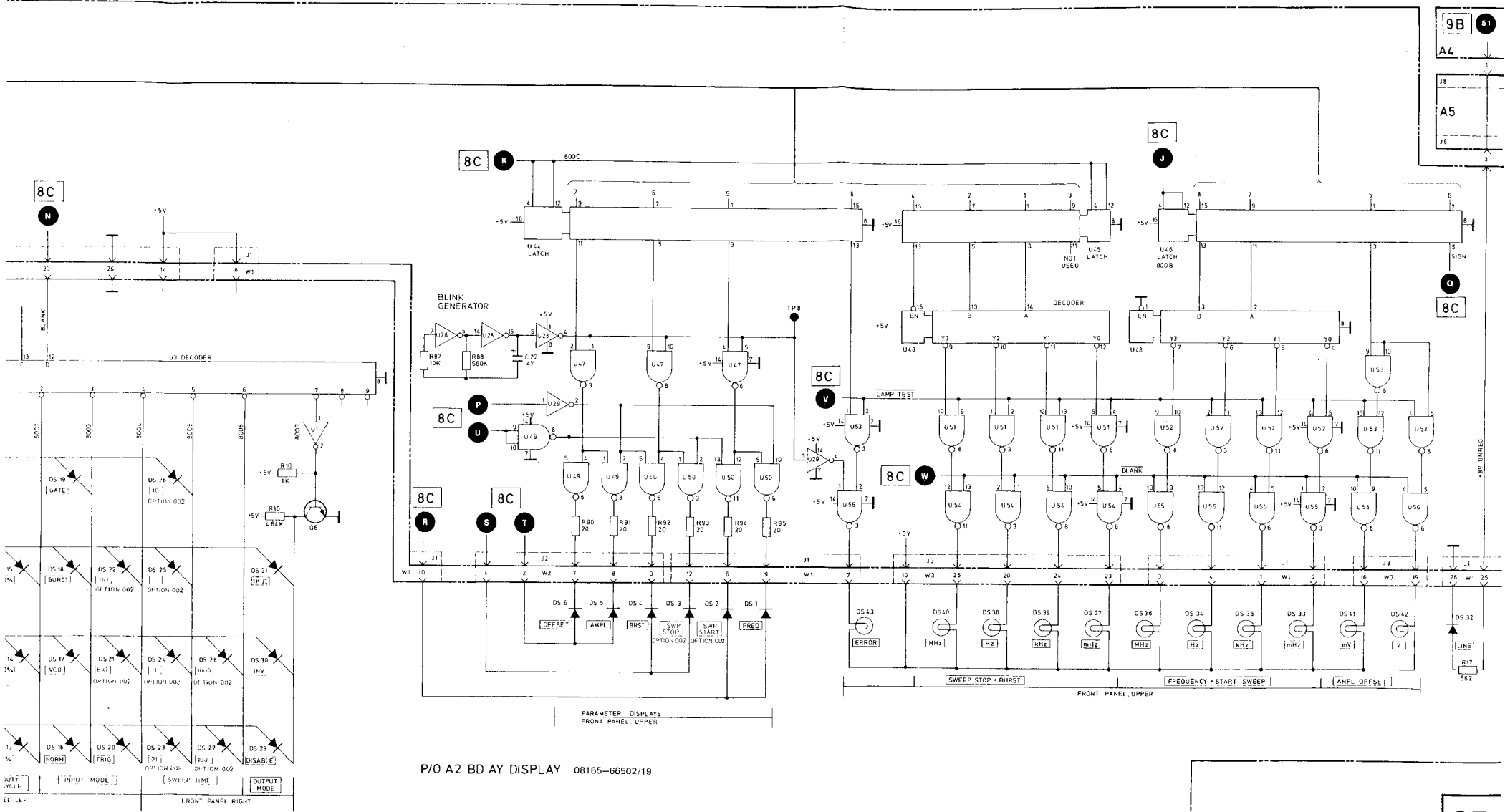

P/O A2 BD AY DISPLAY 08165-66502/19

A2, A3 INDICATOR DISPLAY

8D

P/O A3 BD AY PROCESSOR 08165-66523

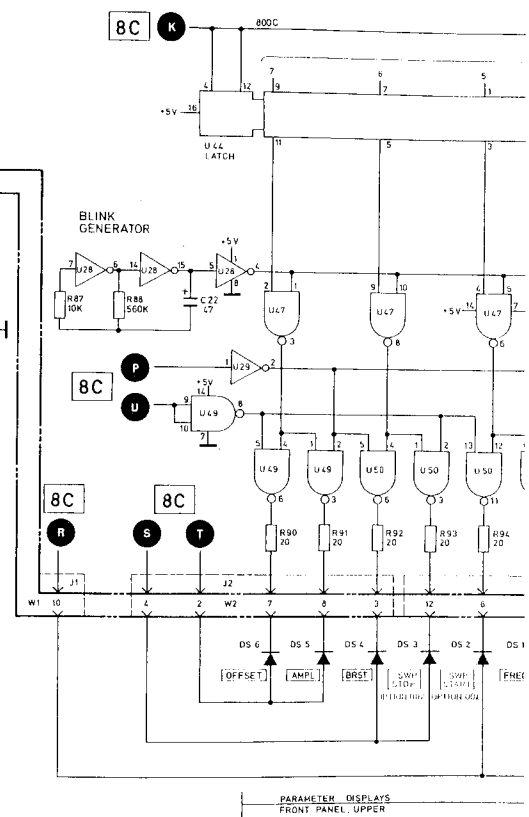
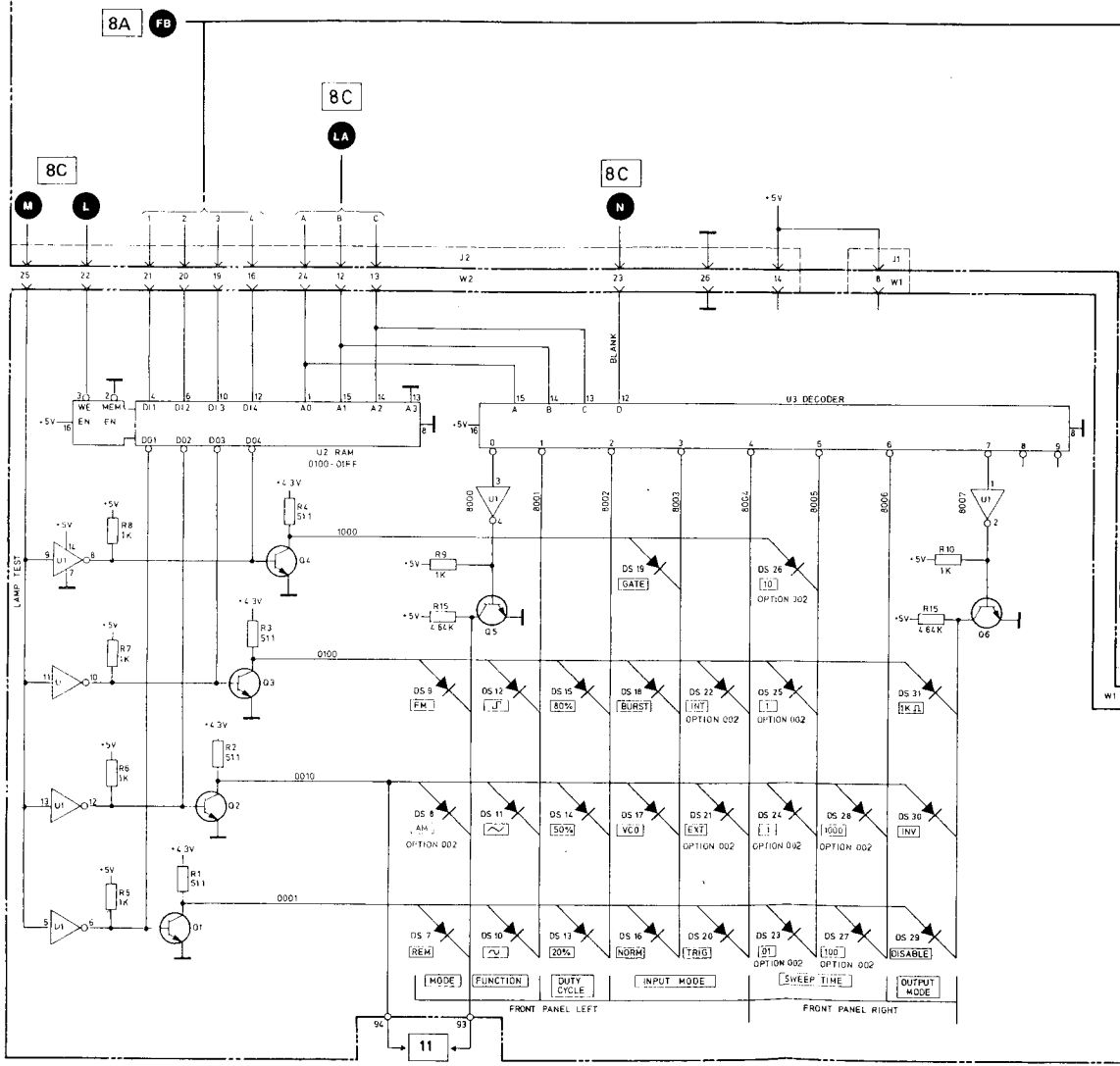

P/O A2 BD AY DISPLAY 08165-66502/19

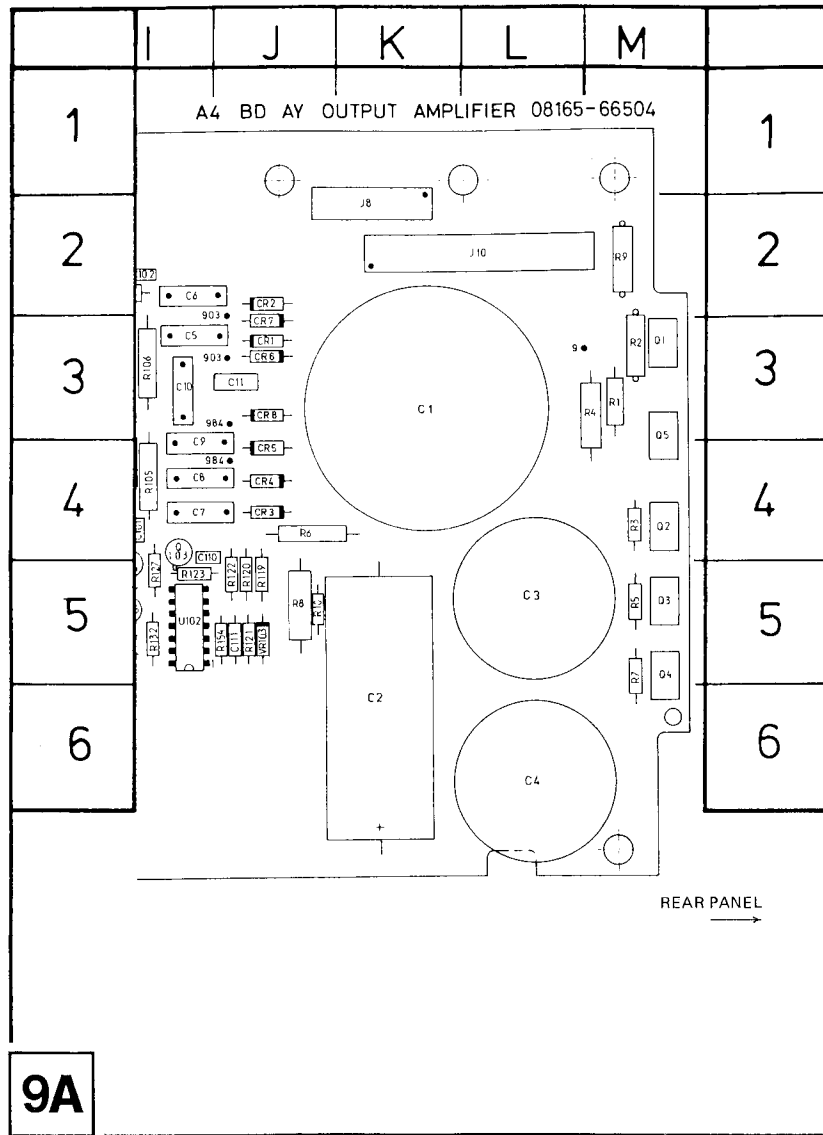

9A

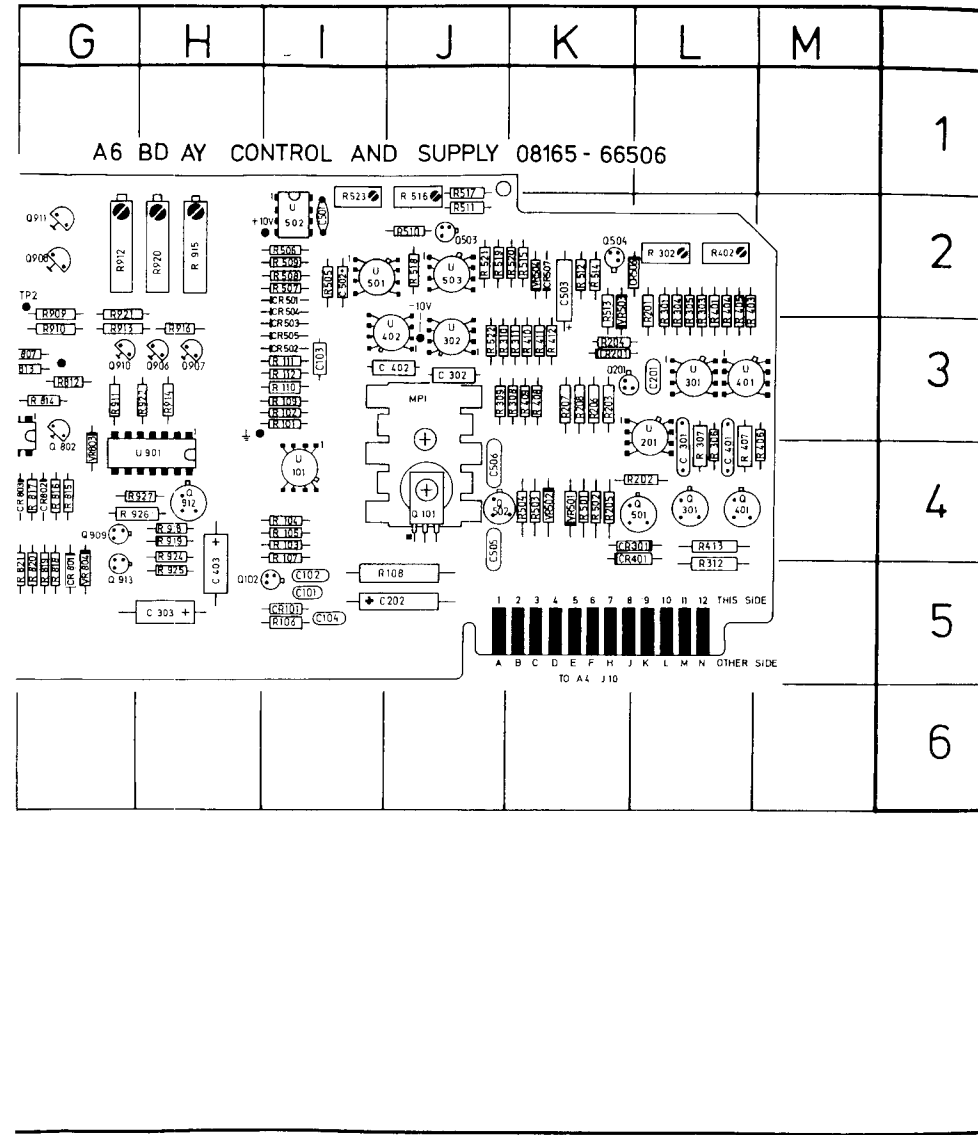

SERVICE BLOCK 6 POWER SUPPLY A4, A6

9A

9B

THEORY OF OPERATION

The 8165A operates from 100 V, 120 V, 200 V or 220 V line supplies, the necessary switching of the transformer, T1, primary windings being accomplished via VOLTAGE SELECTOR switch S2. The transformer outputs are then rectified and regulated to generate the following supplies:

- a) ± 20 V
- b) ± 5 V
- c) +32 V/−29 V

The rectified, but unregulated, transformer output for the +5 V supply is routed to the Display Board A2 to illuminate the LINE lamp.

± 20 V Supplies (Service Sheet 9A)

Before regulation, the rectified transformer outputs for the ± 20 V supplies are used to generate auxiliary and reference voltages for the entire power circuits. These voltages are as follows:

+10 V via Zener diode VR501, R501, R502 and Q501. This voltage is an auxiliary supply used only for power circuit operation.

−10 V via Zener diode VR502, R503, R504 and Q502. This voltage is also an auxiliary supply used only for power circuit operation.

6.2 V via current source Q504 and temperature compensating Zener diode VR504. This voltage is the reference voltage for the ± 5 V and ± 20 V supplies.

The 6.2 V Zener voltage is divided to derive ± 5 V reference voltages at U503 input pins 3 and 6. U503 converts both reference voltages for low output impedance, the U503 outputs $+5 V_{REF}$ and $-5 V_{REF}$ then being used as reference inputs for the ± 5 V and ± 20 V regulators.

The operating principle for all 4 regulators is identical, therefore only one, the +20 V regulator, is described here. A simplified functional diagram illustrating operating principle is shown in Figure 1. The error amplifier U301 compares U_{reg} with U_{ref} and drives the regulator transistor Q3 to zero difference. Excessive output current is then detected by R16 and the overload amplifier U302 (input pins 2 and 3) the output of which goes high if an overload occurs.

± 5 V Supplies (Service Sheet 9B)

Each of the \pm supply circuits comprise a regulator and overload detect circuit, the operating principles for which have been described in the previous paragraph.

Switch-off Circuit (Service Sheet 9A)

An overload signal from an overload amplifier cuts off diode CR501 and the inverting input of U501 goes high. The output of U501 goes low and triggers the Timer U502. The Timer then drives transistor Q503, which shorts the reference voltage, causing all regulated voltages to go down. After a time determined by the time constant of R509 and C502, the timer output goes low again and cuts off Q503. With Q503 cut off, C503 begins to charge up, thus ensuring a slow ramp-like rise to the reference voltage, 6.2 V, at VR504. If the overload still exists, the whole procedure starts again.

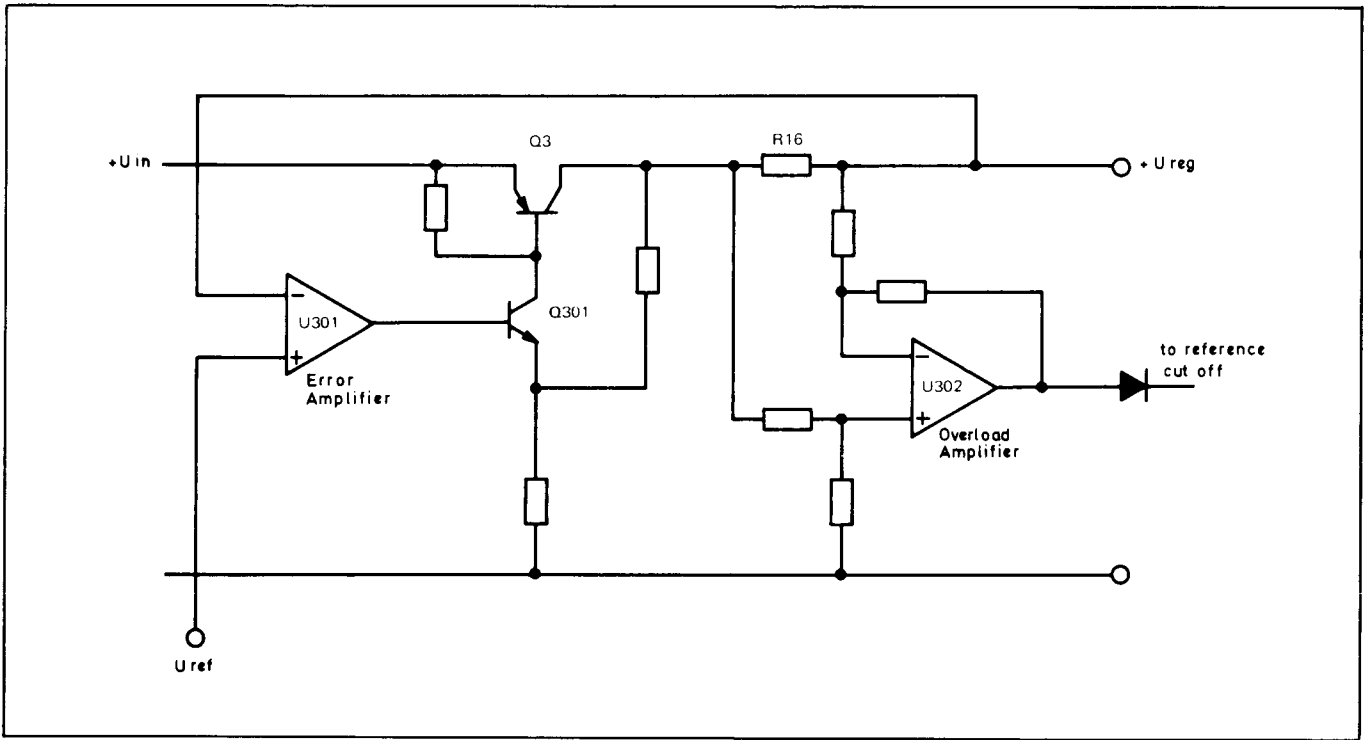

Figure 8-6-1. Principle of fixed voltage regulator

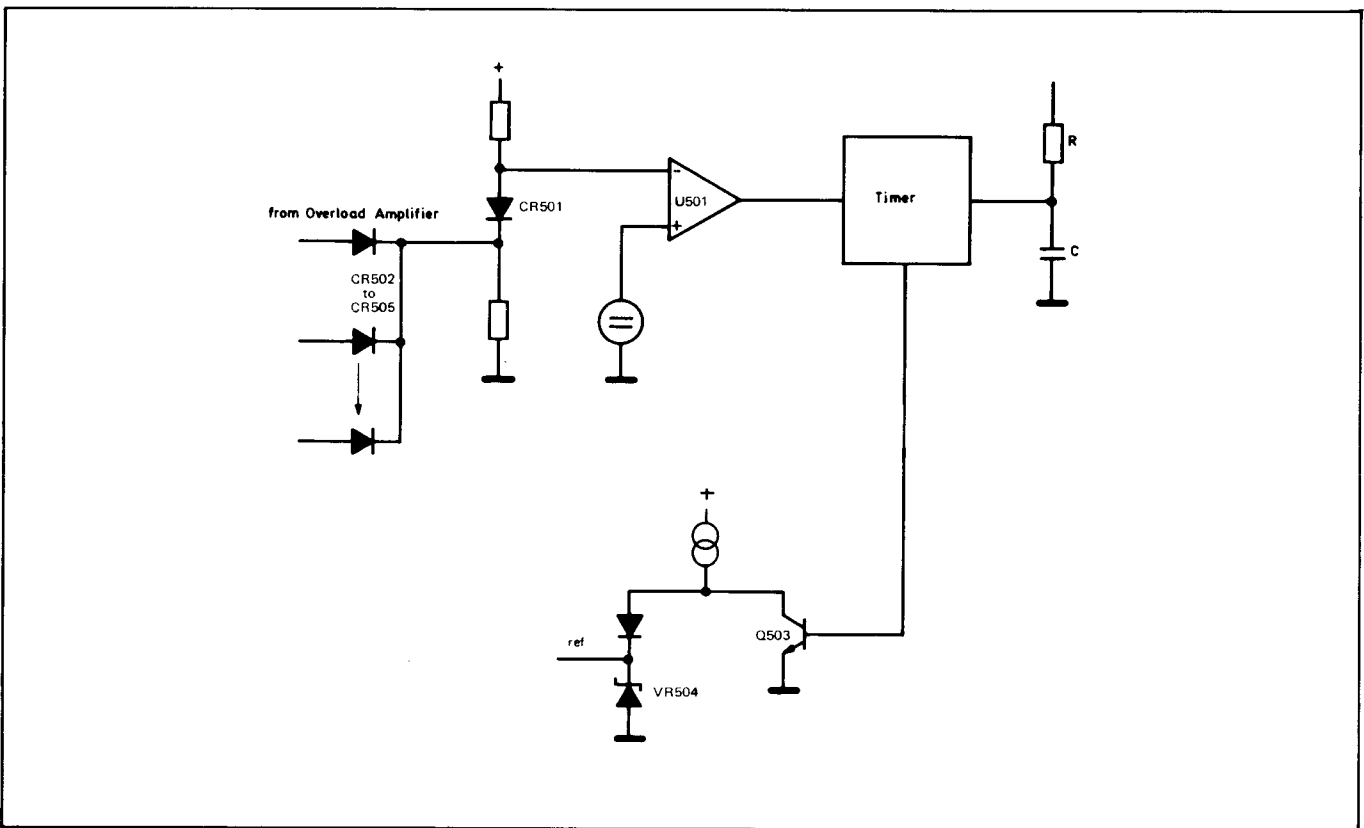

Figure 8-6-2. Reference shutdown circuit.

TROUBLESHOOTING

Replacement of Power Supply Transistors +5 V, Q1, Q5, -5 V Q2, +20 V Q3, -20 V Q4.

These 5 transistors are mounted to the rear panel heat-sink. In order to replace one of the transistors, remove the 2 screws which fasten the heat sink to the rear panel, then push the heat sink with both hands to the top and fold out.

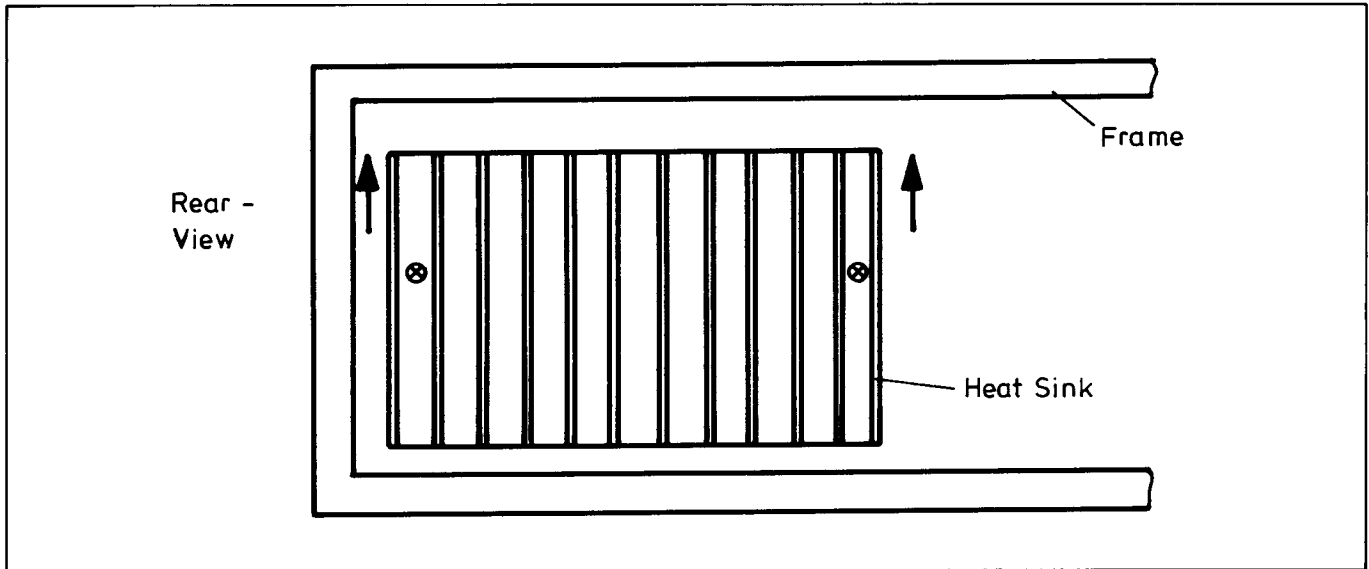

Figure 8-6-3. Heat-sink dis-assembling

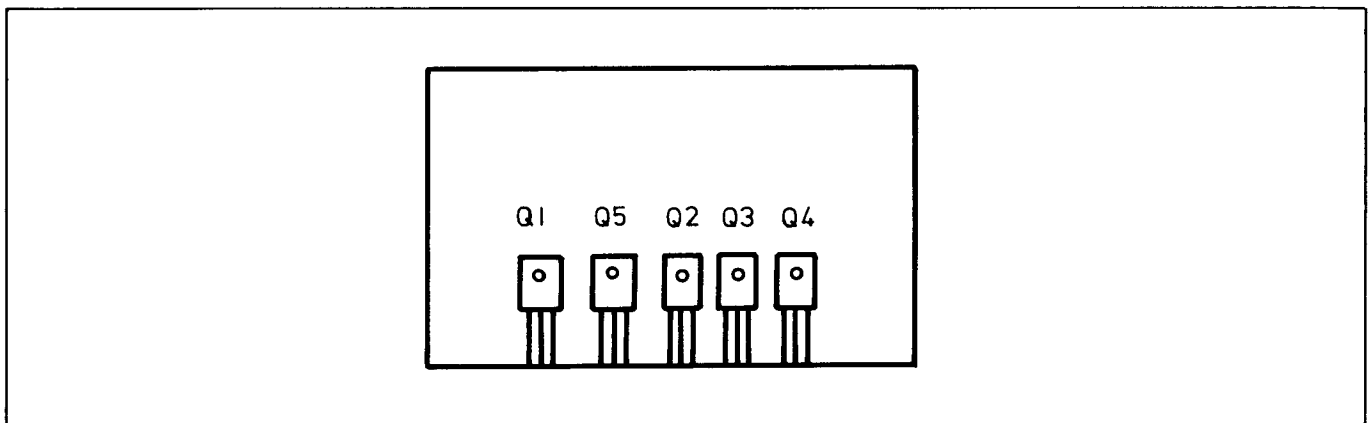
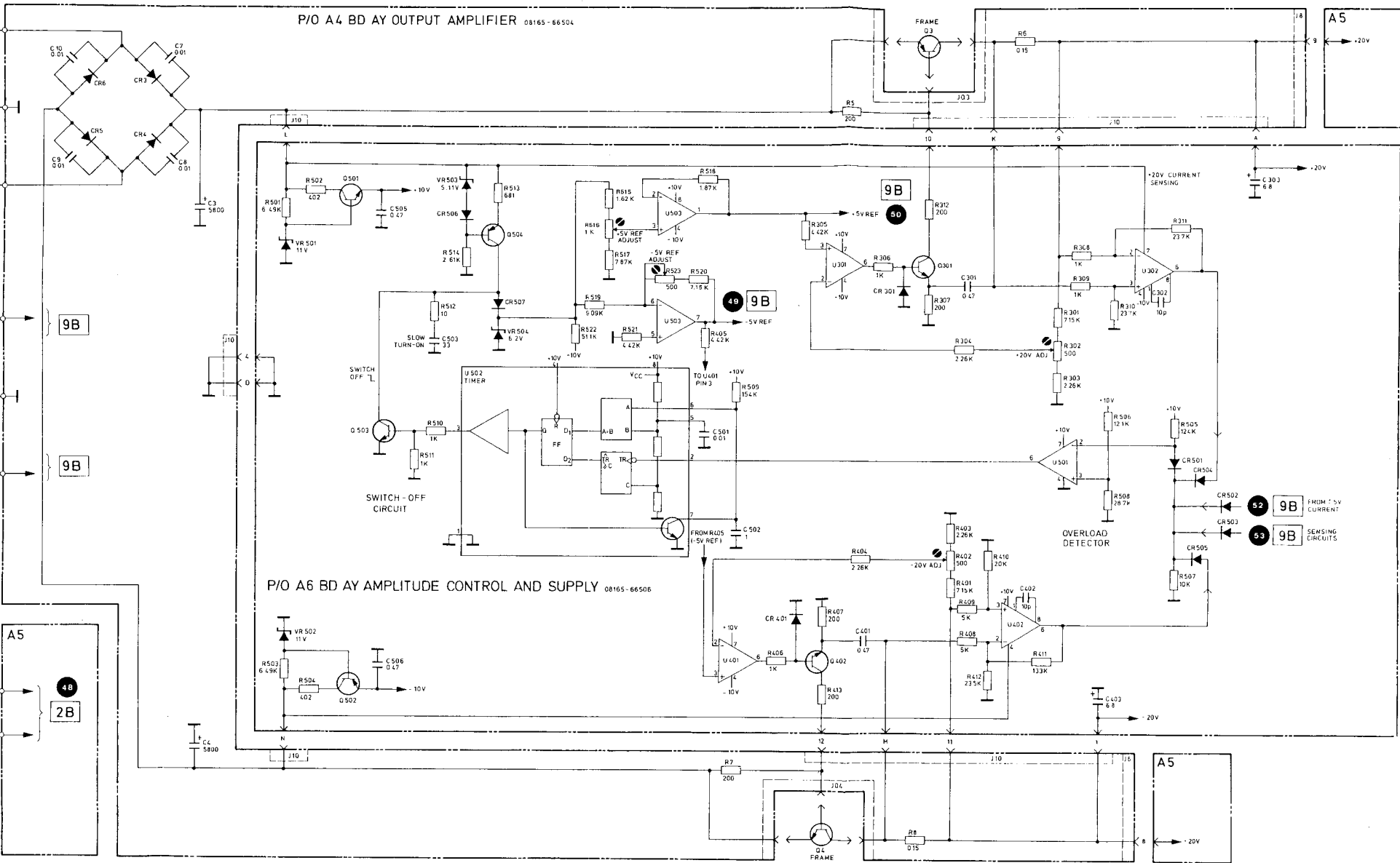

Figure 8-6-4. Heat-sink rear-view



FRAME A4, A6 ± 20V SUPPLIES



Model 8165A

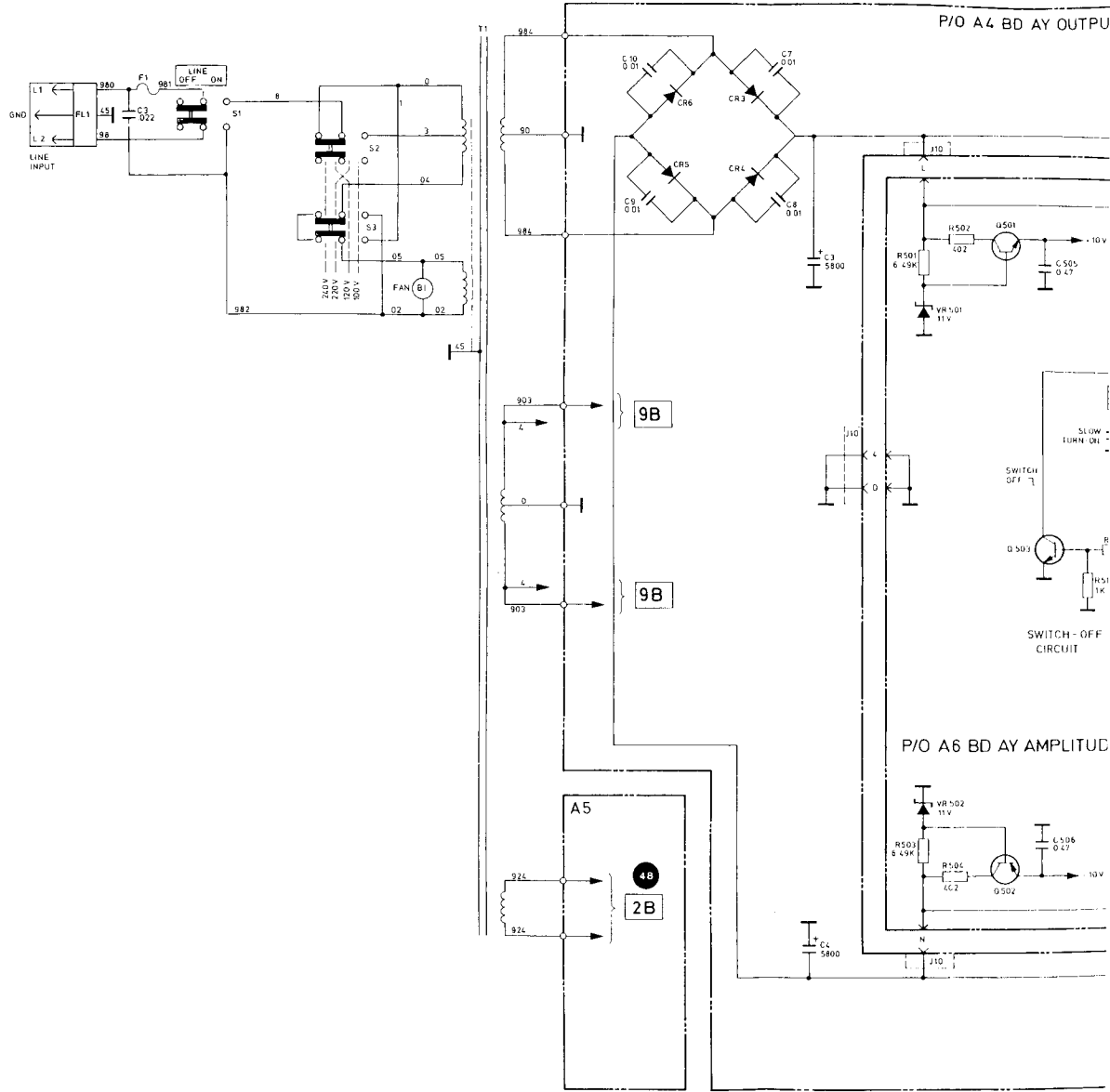

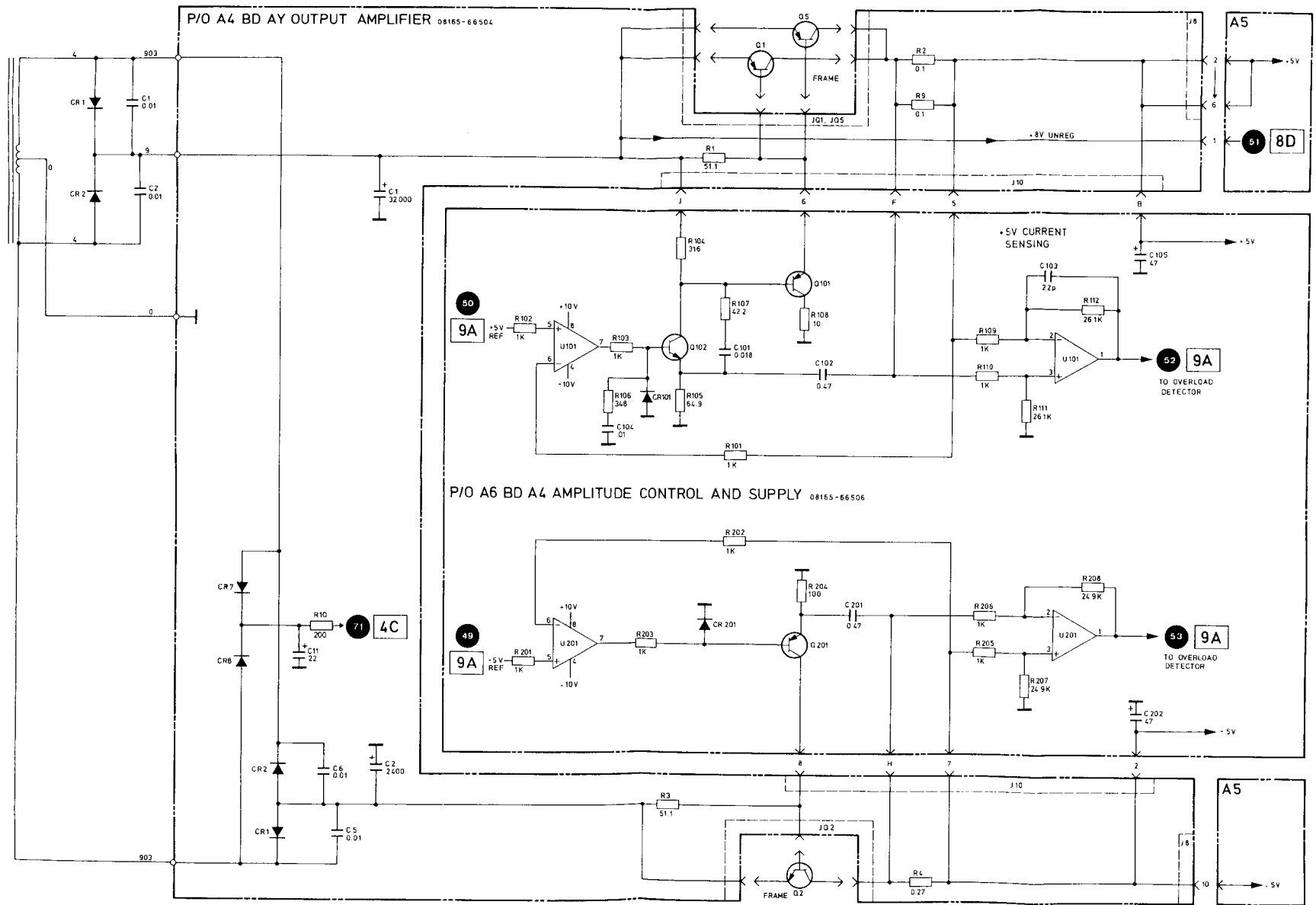

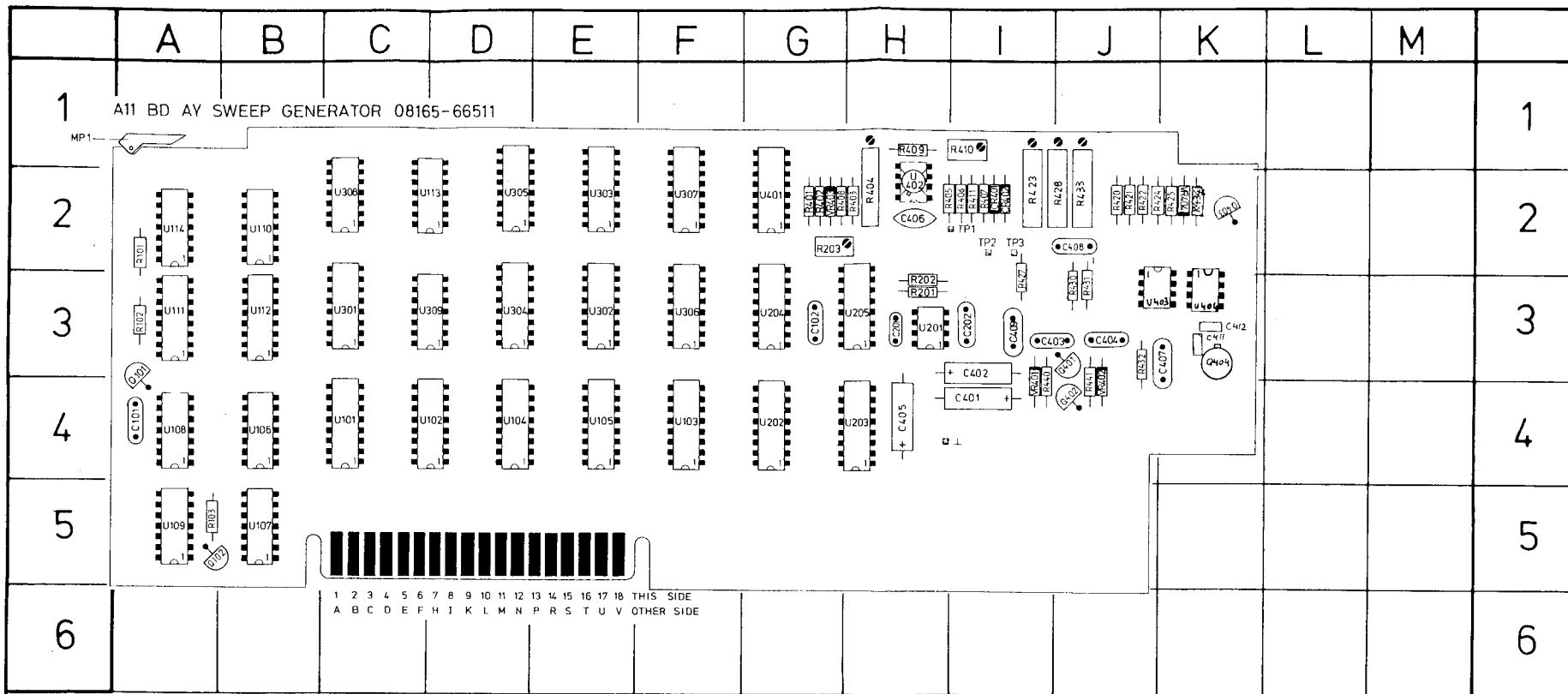

REF DESIG	GRID LOC	REF DESIG	GRID LOC	REF DESIG	GRID LOC	REF DESIG	GRID LOC	REF DESIG	GRID LOC	REF DESIG	GRID LOC
C101	A4	CR403	I2	R401	G2	R424	I2	U104	D4	U205	H3
C102	G3	CR421	J2	R402	G2	R425	J2	U105	E4	U301	C3
C201	H3	CR422	J2	R403	H2	R426	I2	U106	B4	U302	E3
C202	I3	CR423	J2	R404	H1	R427	J2	U107	B5	U303	E2
C401	I4	Q101	A3	R405	I2	R428	J1	U108	A4	U304	D3
C402	I3	Q102	A5	R406	I2			U109	A5	U305	D2
C403	I3	Q401	J3	R407	I2	R429	J2	U110	B2	U306	F3
C404	J3	Q402	J4	R408	G2	R430	J2	U111	A3	U307	F2
C405	H4	Q403	J3	R409	H1	R431	J2	U112	B3	U308	C2
C406	H2	R101	A2	R410	I1	R432	K2	U113	C2	U309	C3
C407	J2	R102	A3	R411	I2	R440	I3	U114	A2	U401	G2
C408	J1	R103	A5	R420	J3	R441	J3	U201	H3	U402	H2
C409	H2	R201	H3	R421	J2	U101	C4	U202	G4	U403	J2
CR401	G2	R202	H3	R422	J3	U102	C4	U203	H4	VR401	I3
CR402	J3	R203	G2	R423	I1	U103	F4	U204	G3	VR402	J3

10

SERVICE BLOCK 7 SWEEP A11

10

THEORY OF OPERATION

A functional diagram of the sweep circuits is given in Figure 8-7-1. From the diagram it can be seen that the sweep generator mainly comprises an up/down counter (F_D counter on service sheet 10), a clock circuit (U201), start/stop latches (U101 to U106), start/stop comparators (F_D/F_{STOP} and F_D/F_{START} on Service sheet 10), a D/A converter (U401) and an anti-log amplifier.

After the start frequency has been entered, the microprocessor checks the stop frequency for total available sweep range. The sweep data acceptor is then addressed and the logarithms of the stop and start frequencies are entered into the latches (U101, U102, U103, U104, U105, U106).

Depending on whether internal or external trigger mode is selected, bit 13 is set to 1 (ext.) or 0 (int.). With internal trigger selected, the input mode clock CLM (signal 1) transfers the bit 13 low to the pin 13 input of NAND gate U114, thus causing the pin 11 output to go high. Flip-flop U112 is set and the F_D counter is loaded with the *inverted* start frequency information from the latches. Correspondingly, when external trigger is selected, signal LFT (generated from the external input signal), clocks flip-flop U111, causing the \bar{Q} output to go low. NAND gate U114 output goes high and sets flip-flop U112, which in turn loads the F_D counter with *inverted* start frequency information.

With the counted loaded, the $F_D = F_{START}$ condition at the comparator U307 resets flip-flop U112 (pin 12) via OR gate U110 pin 9. This causes the Q output to go low which creates the *count down* condition for the F_D counter when it is clocked by U202. (Although the sweep is upwards when sweeping from the programmed start to the programmed stop frequency, the counter counts down during this sweep interval due to the sweep data latch inversion). The $F_D > F_{START}$ condition holds the flip-flop U112 in the reset state until the $F_D = F_{STOP}$ condition is detected by comparator U305. This then sets flip-flop U112 via OR gate U110, pin 13. The Q output goes high and the counter then begins to *count up*.

The counter's output is converted to a triangular waveform by the 10-bit D/A converter U401. The D/A converter output is then routed to an anti-log amplifier to produce a VCO control voltage, and also routed to a buffer to provide a signal for external deflection purposes.

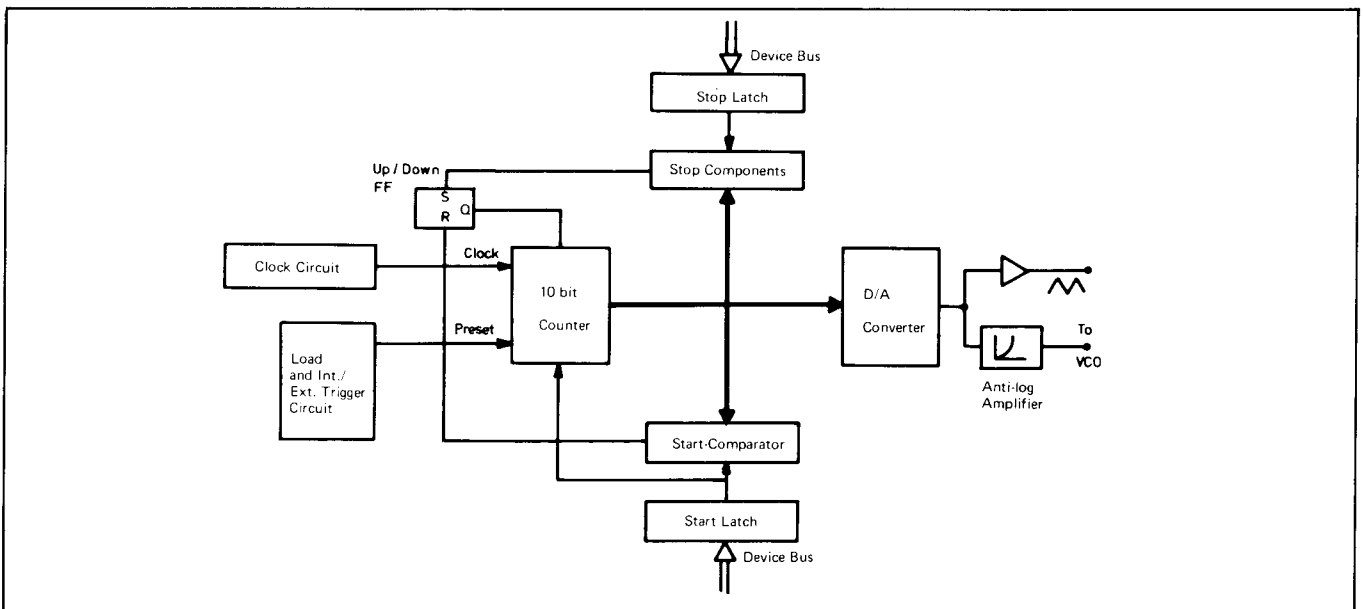

Figure 8-7-1. Sweep block diagram

TROUBLESHOOTING

This troubleshooting section mainly contains information in order to check the transferred data.

Table 8-7-1. Sweep Mode Data Transfer

bit	16 15 14 13	12 11 10 9	8 7 6 5	4 3 2 1	
	1 1 1 1 x x x x	1 1 1 1 x x x x	1 1 1 1 x x x x	0 1 1 1 x x x x	Waveform address Waveform data
	1 1 1 1 x x x x	1 1 1 1 x x x x	1 1 1 1 x x x x	1 1 0 1 x x x x	Input mode address Input mode data
	1 1 1 1 x x x x	1 1 1 1 x x x x	1 1 1 1 x x x x	1 1 1 0 x x x x	Frequency address Frequency data
	x x x x x x x x	x x x x x x x x	x x x x x x x x	x x x x x x x x	Frequency data Frequency data
Sweep mode data are transferred with input mode data.					

Table 8-7-2. Sweep Mode

	Sweep Ext.	Sweep Int.	No Sweep
Bit 10	1	1	0
Bit 13	1	0	x

Table 8-7-3. Sweep Time Data Transfer

bit	16 15 14 13	12 11 10 9	8 7 6 5	4 3 2 1	
	1 1 1 1 x x x x	1 1 1 1 x x x x	0 1 1 1 x x x x	1 1 1 1 x x x x	Sweep address Sweep time data
	sweep time data		stop - data		

Table 8-7-3. Sweep Time Data Transfer (cont'd)

bit	16 15 14	Sweep time	Clock freq.
	0 0 0	1 ms / decade	34.1 KHz
	0 0 1	10 ms / decade	3.41 KHz
	0 1 0	100 ms / decade	341 Hz
	0 1 1	1 s / decade	34.1 Hz
	1 0 0	10 s / decade	3.41 Hz
	1 0 1	100 s / decade	0.341 Hz

Table 8-7-4. Start/Stop Data Transfer

bit	16 15 14 13	12 11 10 9	8 7 6 5	4 3 2 1	
	1 1 1 1	1 1 1 1	0 1 1 1	1 1 1 1	Sweep address
	x x x x	x x x x	x x x x	x x x x	Sweep stop data
	x x x x	x x x x	x x x x	x x x x	Sweep start data
	1 1 1 1	1 1 1 1	1 1 1 1	0 1 1 1	Waveform address
	x x x x	x x x x	x x x x	x x x x	Waveform data
	1 1 1 1	1 1 1 1	1 1 1 1	1 1 0 1	Input mode address
	x x x x	x x x x	x x x x	x x x x	Input mode data
	1 1 1 1	1 1 1 1	1 1 1 1	1 1 1 0	Frequency address
	x x x x	x x x x	x x x x	x x x x	Frequency data first set only

The STOP frequency determines (via μP) which VCO time constant will be selected.

Bit 1 to 9 transfers start and stop data.

Table 8-7-5. Start/Stop Data – Output Voltage Diagram

bit	9 8 7 6 5 4 3 2 1	decimal	V Sweep out	V anti log out
	0 0 0 0 0 0 0 0 0	0	3.00 V	0.01 V
	0 0 1 0 1 0 1 0 1	85	2.50 V	0.0316 V
	0 0 1 1 1 0 1 1 1	119	2.3 V	0.0501 V
	0 1 0 0 1 1 0 0 1	153	2.1 V	0.0794 V
	0 1 0 1 0 1 0 1 0	170	2.00 V	0.1 V
	0 1 1 0 0 1 1 0 0	204	1.8 V	0.158 V
	0 1 1 1 1 1 1 1 1	255	1.5 V	0.316 V
	1 0 0 1 0 0 0 0 1	289	1.3 V	0.501 V
	1 0 1 0 0 0 0 0 1	323	1.1 V	0.794 V
	1 0 1 0 1 0 1 0 0	340	1.0 V	1.0 V
	1 0 1 1 1 0 1 1 0	374	0.8 V	1.585 V
	1 1 0 1 0 1 0 0 1	425	0.5 V	3.162 V
	1 1 1 0 0 1 0 0 0	456	0.3 V	5.01 V
	1 1 1 1 0 1 1 1 0	494	0.1 V	7.94 V
	1 1 1 1 1 1 1 1 1	511	0 V	10.0 V

Bit 10 of the F_D Counter will be set with load

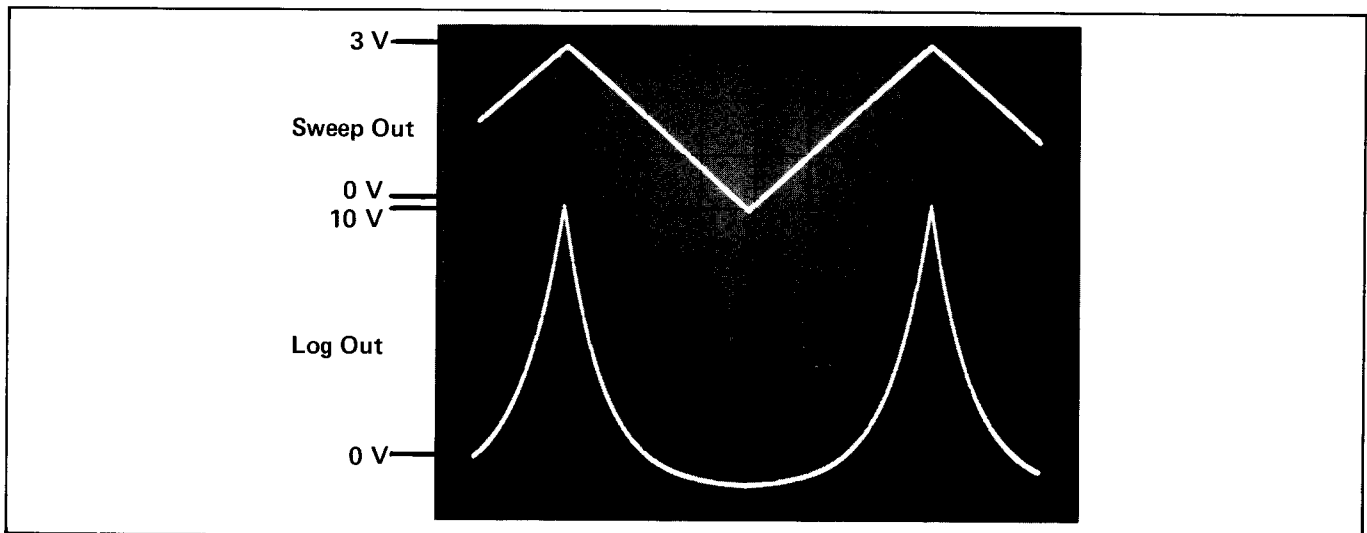
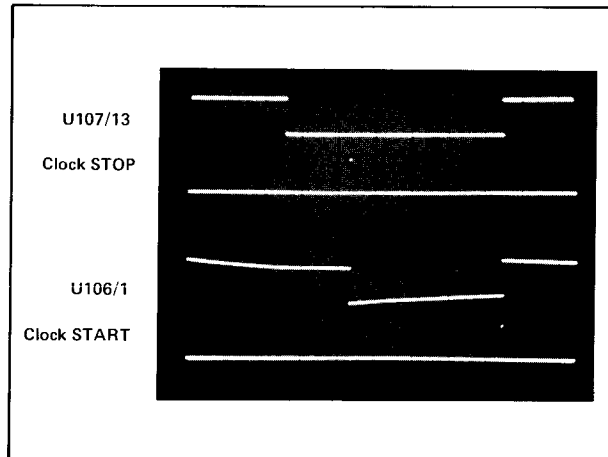
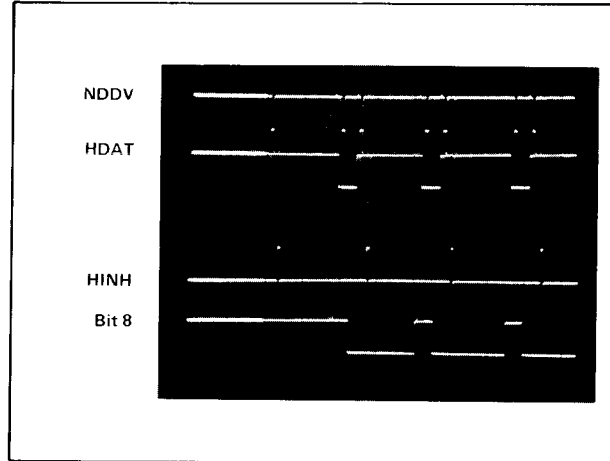
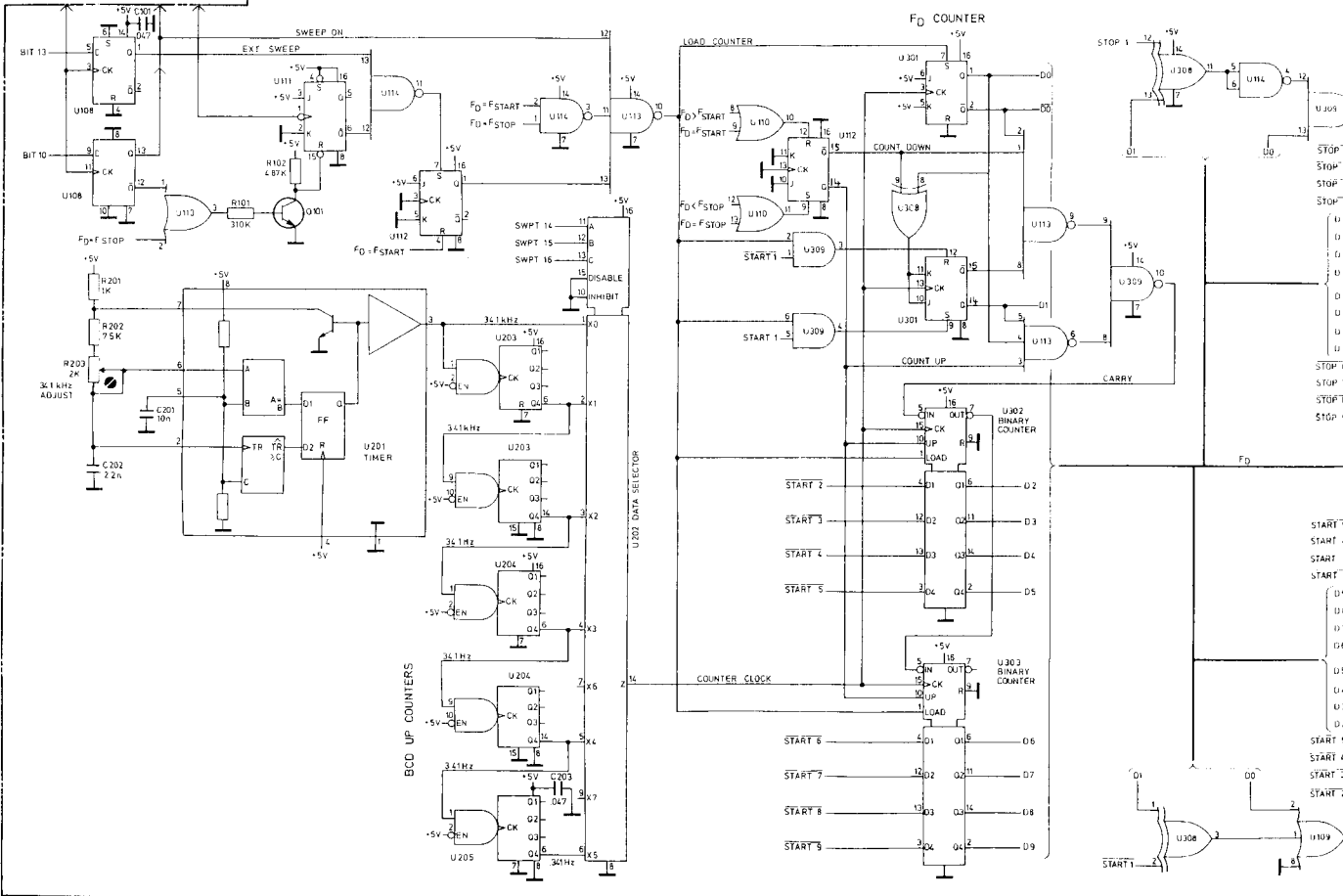
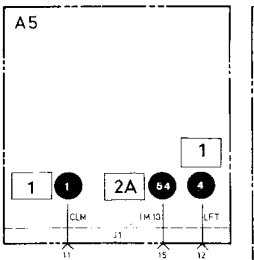

Figure 8-7-2. Start/Stop data set for max. output signal (3 decades)

**Sweep Mode Acceptor
(all signals TTL)**



For repeating signals a controller is needed.
Program: wrt 716, "STA 1 kHz, STP 10 kHz"; jmp 0
For device bus details see SERVICE BLOCK 1.



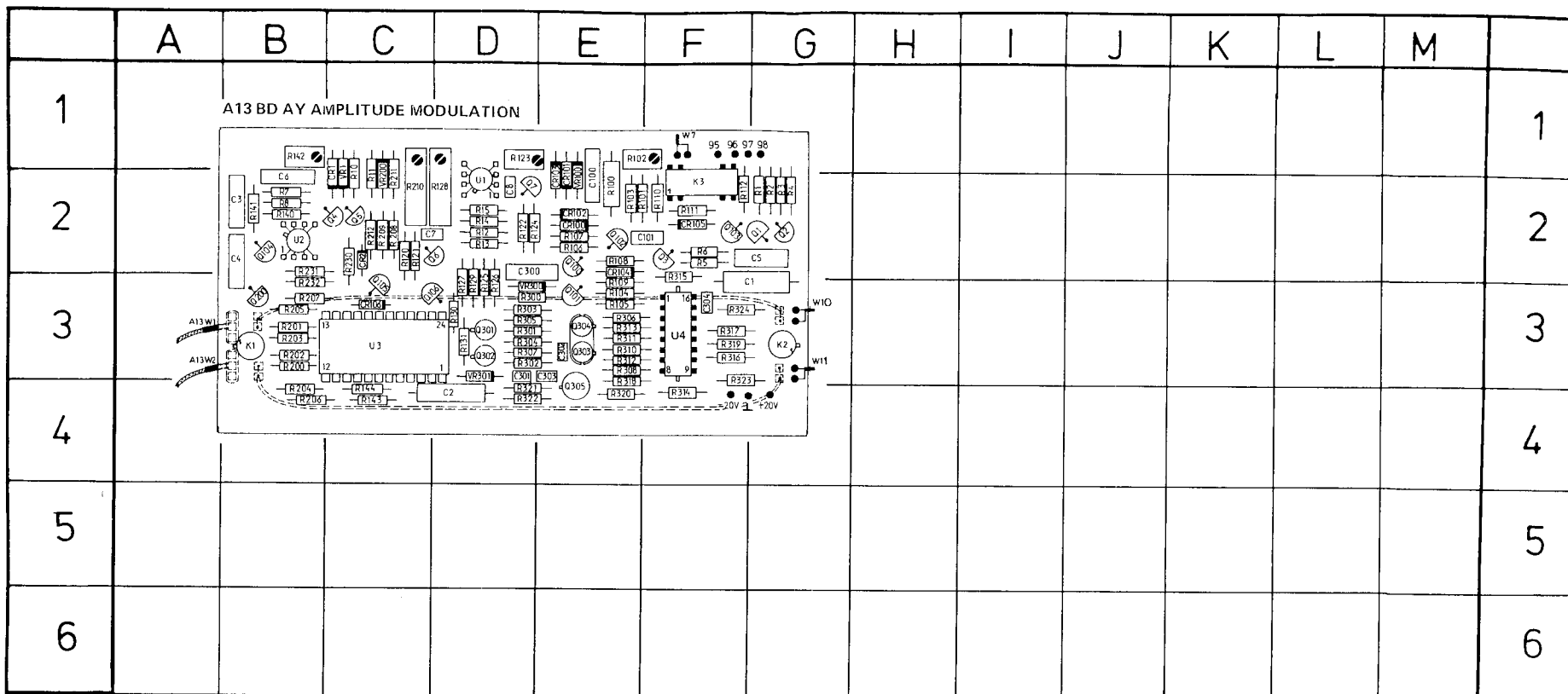

REF DESIG	GRID LOC	REF DESIG	GRID LOC	REF DESIG	GRID LOC	REF DESIG	GRID LOC	REF DESIG	GRID LOC	REF DESIG	GRID LOC	REF DESIG	GRID LOC	REF DESIG	GRID LOC	REF DESIG	GRID LOC				
C1	G3	CR1	C2	Q2	G2	Q301	D3	R11	C2	R109	E3	R130	D3	R207	B3	R305	D3	R320	E4	W1	B3
C2	D4	CR2	C2	Q3	G2	Q302	D3	R12	D2	R110	F2	R131	D3	R208	C2	R306	E3	R321	D4	W2	B2
C3	B2	CR100	E2	Q4	C2	Q303	E3	R13	D2	R111	F2	R140	B2	R209	C2	R307	D3	R322	D4		
C4	B2	CR101	E2	Q5	C2	Q304	E3	R14	D2	R112	F2	R141	B2	R210	C2	R308	E3	R323	F3		
C5	G2	CR102	E2	Q6	D2	Q305	E4	R15	D2	R120	C2	R142	B1	R211	C2	R310	E3	R324	F3		
C6	B2	CR103	E2	Q7	D2	R1	G2	R100	E2	R121	C2	R143	C4	R212	C2	R311	E3	U1	D2		
C7	D2	CR104	E2	Q100	E2	R2	G2	R101	F2	R122	D2	R144	C4	R230	C2	R312	E3	U2	B2		
C8	D2	CR105	F2	Q101	E3	R3	G2	R102	E/F1	R123	D1	R200	B3	R231	B2	R313	E3	U3	C3		
C10	E2	CR106	C3	Q102	E2	R4	G2	R103	E2	R124	D2	R201	B3	R232	B3	R314	F4	U4	F3		
C300	D2/3	K1	B3	Q103	F2	R5	F2	R104	E3	R125	D3	R202	B3	R300	D3	R315	F3	VR1	C2		
C301	D3	K2	G3	Q104	B2	R6	F2	R105	E3	R126	D3	R203	B3	R301	D3	R316	F3	VR100	E2		
C302	E3	K3	F2	Q105	C3	R7	B2	R106	E2	R127	D3	R204	B4	R302	D3	R317	F3	VR200	C2		
C303	E3	MP1	E3	Q106	C3	R8	B2	R107	E2	R128	D2	R205	B3	R303	D3	R318	E4	VR300	D3		
C304	F3	Q1	G2	Q200	B3	R10	C2	R108	E2	R129	D3	R206	B4	R304	D3	R319	F3	VR301	D4		

11

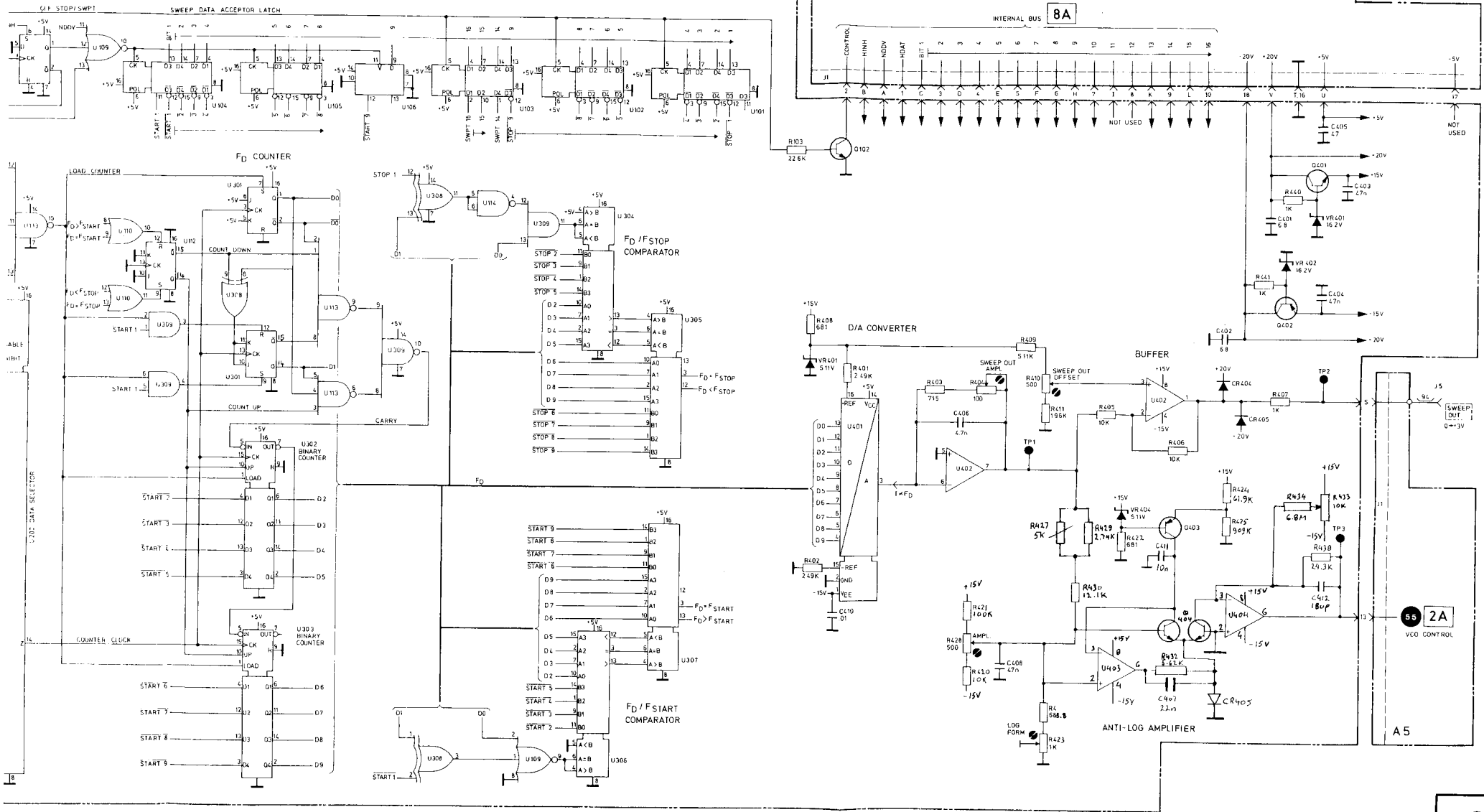

A11 SWEEP GENERATOR

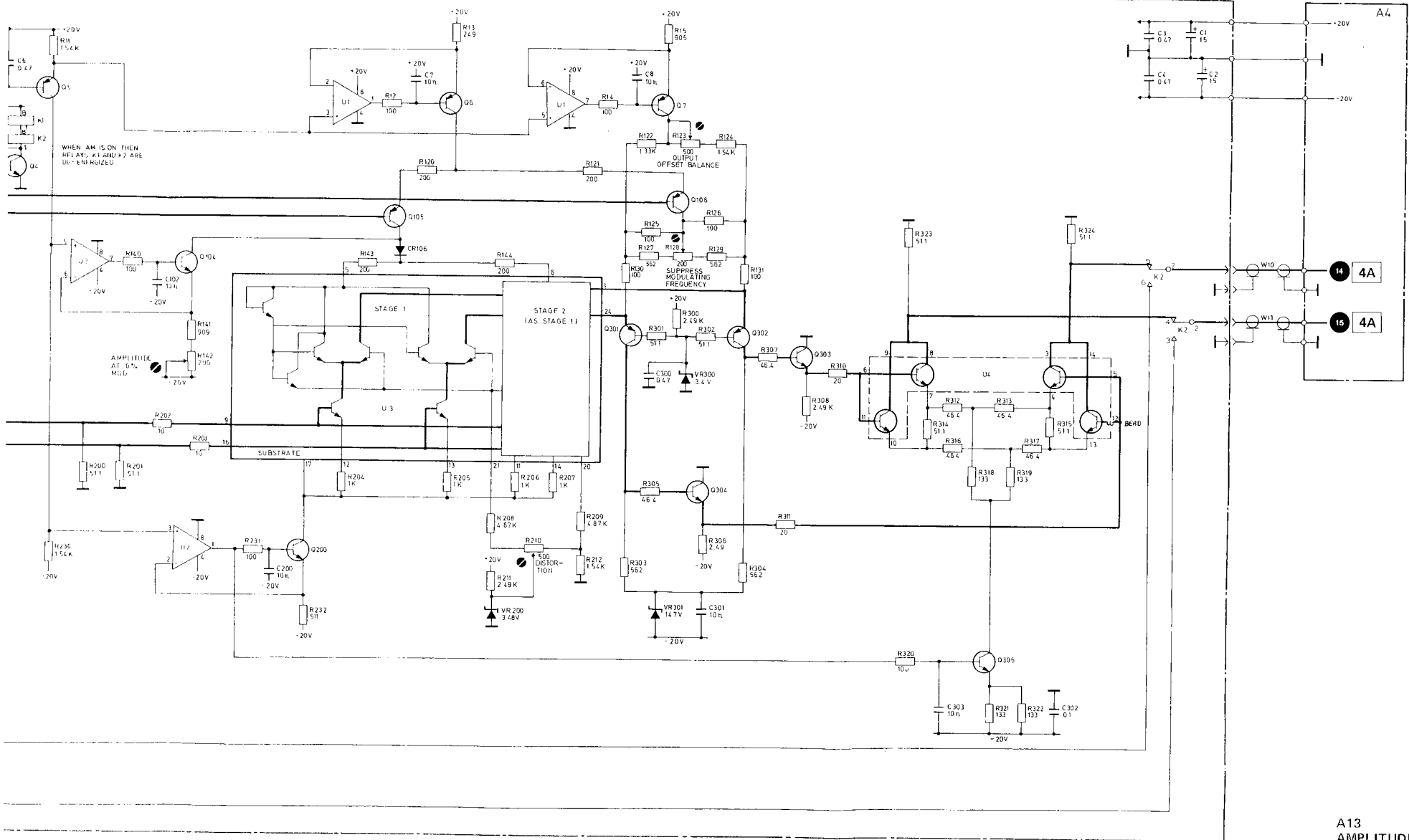

A13
AMPLITUDE
MODULATOR

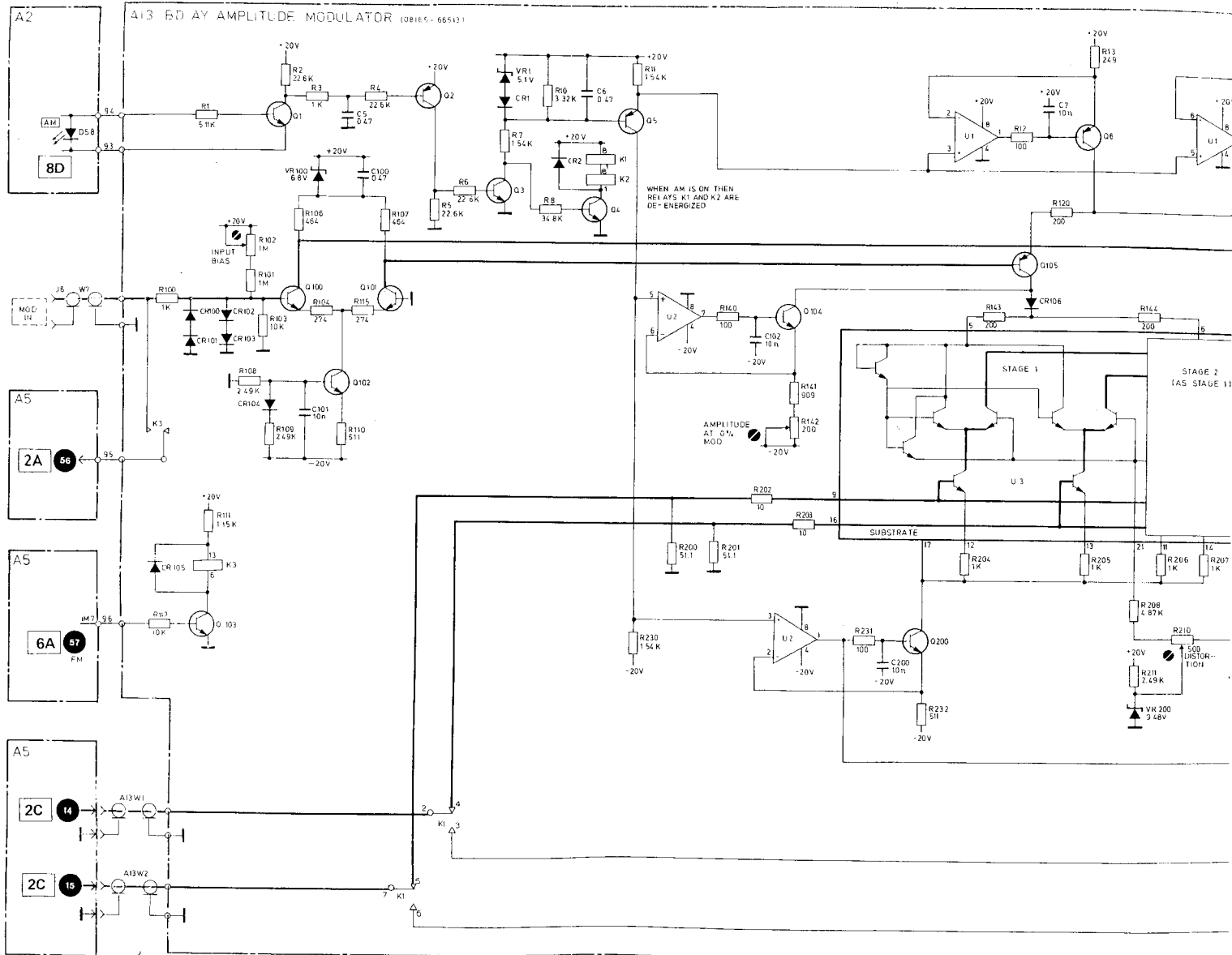

SERVICE BLOCK 8 AMPLITUDE MODULATOR 11

THEORY OF OPERATION

The microprocessor-derived lamp drive signal to the AM LED, DS8, is also used to switch the amplitude modulator on and off. When the AM LED is illuminated, A13Q1 is switched on, causing Q4 to switch off, and relays K1 and K2 remain de-energized. In this relay state, the amplitude modulator is on.

The carrier signal from the A5 output driver is then routed to the modulating IC U3, which comprises 2 attenuator stages in parallel. (The operation of U3 is identical to that of the active vernier IC, described in detail in Service Block 4. Briefly, each stage is a differential amplifier connected so that the signal current flows into (or out of) the common emitters. The output current is taken from one of the collectors and then converted to voltage).

The modulating signal, at the MOD IN connector, is clamped to 2.5 V pp via diodes CR100 → CR103, and routed via differential amplifier Q100/Q101 to differential amplifier Q105/Q106. Through the action of Q105/Q106, a push-pull effect takes place on the carrier signal — the current drawn at the Q105 collector through the two modulator stages being compensated by the Q106 collector current at the two modulator outputs. Because of the limited common mode rejection of the pre-amplifier U4, good balancing is necessary between the two modulator IC outputs, and this is achieved by variable resistor R128. Via this resistor, current through the two base stages Q301 and Q302 can be adjusted.

Emitter followers Q303 and Q304 then provides the necessary conversion to low impedance for the inputs to pre-amplifier U4.



**HEWLETT
PACKARD**

MANUAL CHANGES

Manual for Model Number	8165A
Manual printed on	Sept. 1983
Manual Part Number	08165-90005

Make all **ERRATA** corrections.

Check the following table for your instrument serial prefix/serial number and make the listed changes to your manual.

► New Item

Serial Prefix or Serial Number		Manual Changes	Serial Prefix or Serial Number	Manual Changes
ERRATA				
248G02191	and above	1		
2248G02241	and above	1-2		
2248G02291	and above	1-3		
2248G02341	and above	1-4		
2248G02616	and above	1-5		
2248G02641	and above	1-6		
2248G02691	and above	1-7		
2248G02711	and above	1-8		
2515G02731	and above	1-9		
2515G02891	and above	1-10		
2515G02911	and above	1-11		
2515G02931	and above	1-12		
2515G02971	and above	1-13		
2515G02991	and above	1-14		
2515G03071	and above	1-15		
2515G03111	and above	1-16		
2515G03251	and above	1-17		
2515G03311	and above	1-18		

INDEX OF MANUAL CHANGES

MANUAL CHANGE

	MISCELLANEOUS	FRAME	A1	A2	A3	A4	A5	A6	A7	A8	A9
	Page 1-2, 1-3, 1-4 " 3-0, 3-11, 4-6, " 4-7, 4-12, 4-15, " 5-15, 6-6, 6-7, " 6-9, 6-12, 6-39, " 6-42, 6-44, 8-44 " 8-69, 8-74, 8-103 " 8-114, 8-121, " 8-133, 8-136, " 8-143, 5-4			DS2, 3	U18						
ERRATA											
1	8-94, 8-95, 8-74/75, 8-77, 8-79, 8-144, 8-147	C3, MP16, MP28 thru MP38,			R21	C125*, C306, 307 R120, 155	C13, 14 R339, 530			C202 R433*, R436*	
2		MP45, 46 MP47					R341*				
3			MP28-38 MP45-47				A15, 16, A17				
4							R302*				
6											
7							Q7, 303 R359, 361				
8						C113, 121					
						C110, 115, C118, 201, C208, 501	C5, 39, 41, C102, 107, C202, 210, C212, 302, C303, 306, C502		C5		C503
9	Page 1-0	MP8, 24, 25, MP26, 41, 42, MP51, 52, 53									

MANUAL CHANGE	MISCELLANEOUS	FRAME	A1	A2	A3	A4	A5	A6	A7	A8	A9
10	Page 6-12 Page 6-12				U24,25 R96						
11	Page 6-17						C21				
12	Page 6-14					CR3,4,5,6					
13	Page 6-18						C42				
14	Page 6-9			C1,2							
15	Page 6-20						Q21				
16	Table 6-3.					R307,207, R218,318, R106,105	R247 R216,217				
17	Page 6-22/-27						R209	*R909			
18						U201,202	U6,304, U306,	U301,401, U 501		U202,301	U207,302, U303

INDEX OF MANUAL CHANGES

MANUAL CHANGE	Option 002/003										MISCELLANEOUS	
	A10	A12	A14	A15	A16	A17	A2	A11	A13	FRAME		
ERRATA		R13,30								C100,102	F1,J5,A3 MP7,MP19	
1								C101,203 C403,404 C412 CR403,404	L301			
2								C102,103				8-136, 8-143
5									R314,315			
8									C302			
9											MP8	
12	U14, C210											
13							C1,2					

ERRATA

Page 1-2, Table 1-1. Recommended Test Equipment change to read :

INSTRUMENT	RECOMMENDED MODEL	REQUIRED CHARACTERISTICS	USE
10:1 Probe	HP 10006D ↙ ↘	BNC/retractable hook	A
Capacitor	HP 0160-3724	0.47 μF	A
Power Meter	HP 436A	100 K - 50 MHz → 1 μW - 100 mW	P, A
Add: Logic Probe	HP10525E	ECL	

Page 1-3, Table 1-2. Specifications

Frequency Characteristics
Accuracy, Stability and Resolution:

Delete: *Accuracy and stability can be improved by phase locking to an external frequency reference.

Page 1-4, Table 1-2. Specifications:

Auxiliary outputs and inputs:

Delete: Ext 10 MHz ref.:.....

Page 3-0, Figure 3-1.

Delete: all reference to (32) including BNC connector and switch on rear panel.

Add: Locator (33) to upper BNC connector and note (33) connector for internally-generated sweep voltage (Opt.002 only).

Page 3-11, Example using the HP9825A Desktop Computer

Delete: HP9825A computer example

Replace with the following as shown on next page:

ERRATA (Cont.)

Replace as shown :

```
Ø: dim A$ (8,2Ø)
1: wrt 716,"SET:

2: red 716,A$(1)
   ,A$(2),A$(3),
   A$(4),A$(5),
   A$(6),A$(7),
   A$(8)

3: 1→I

4: prt A$(I,1,
   16); I+1→I; jmp
   I > 8

5: end
```

Page 4-6, step 3.

Delete: Verify that the 2nd and 3rd harmonics do not exceed the -42 and -47 dB levels, respectively.

Page 4-7, step 4. change to read :

..... where A_1 = 2nd harmonic in dB etc.

Page 4-12, PERFORMANCE TESTS

PROCEDURE

Add to step 3. Set Delay Dial to 5.0.

Page 4-15, 4-19. AMPLITUDE MODULATOR (Option 002 only).

EQUIPMENT

Add to Figure 4-13.

Link between oscillator output and
oscilloscope channel B input

Add to step 3. alt./Trigger B

ERRATA (Cont.)

On page 5-4, change steps 11.2 to 11.4 of the "HF-Sine Distortion" adjustment procedure to read the following:

11.2 Set 8165A as follows:

FUNCTION	Sine
INPUT MODE	Norm
FREQUENCY	9.99 kHz
AMPLITUDE	10.0 V

11.3 Adjust A17 R340 for minimum 3rd harmonic distortion in NORM and COMP mode.

NOTE

Find the best compromise between a minimum 3rd harmonic distortion and a minimum difference of the 3rd harmonic distortion in NORM and COMP mode.

11.4 Adjust A16 R350 for minimum 2nd harmonic distortion in NORM and COMP mode.

NOTE

Find the best compromise between a minimum 2nd harmonic distortion and a minimum difference of the 2nd harmonic distortion in NORM and COMP mode.

On page 5-4, add step 11.4.1

11.4.1 Connect 8165A output to HF spectrum analyzer and check that THD is less than 1% for the following settings in both NORM and COMP modes:

a) FRO	1.00 MHz	c) FRO	1.00 MHz
AMP	1.99 V	AMP	1.60 V
b) FRO	999 kHz			
AMP	2.00 V			

If necessary, slightly readjust A17 R340 and/or A16 R350. If readjustment was necessary, check that THD is still less than 1% for the settings given in step 11.2.

NOTE

The following formula helps determining the THD when the harmonics are expressed in Decibel (dB) as taken from the spectrum analyzer.

$$THD = \sqrt{10(A2/10) + 10(A3/10) + 10(A4/10) + \dots} \times 100\%$$

where A2 is the 2nd harmonic, A3 the 3rd harmonic, and so on. (Ignore levels below -60 dB).

Page 5-15, Adjustments - Top view and

Page 6-6, Figure 6-1, change the diagram as shown below:

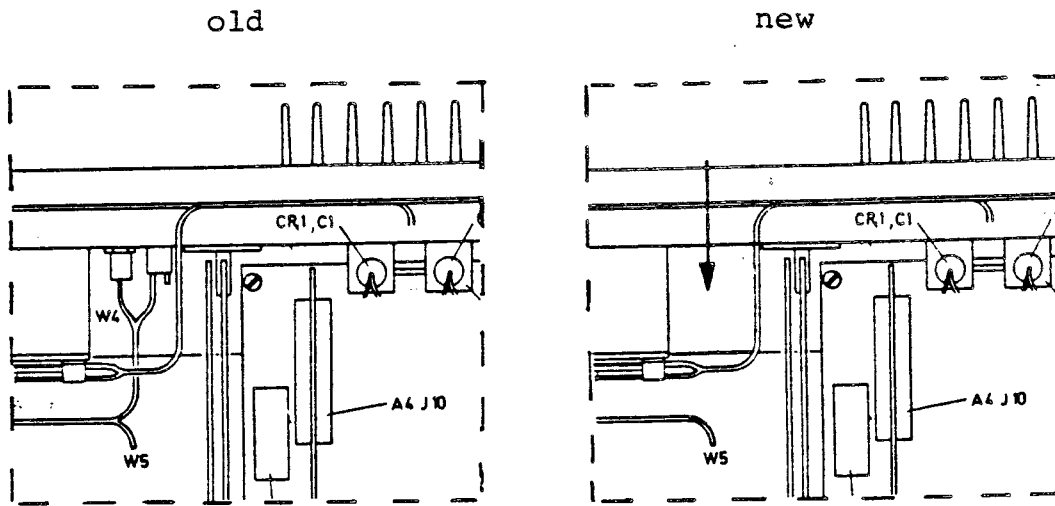

On following pages, change the Table of Replaceable Parts to read:

Page No. (Actual)

Page 6-7	A3	08165-66523	BD-ASSY PROCESSOR
Page 6-37	A12 R13,30	0683-2255	R-FXD 2.2M 5% .25W
Page 6-44	A13 C100	0160-0174	C-FXD .47UF 20% 25VDC
<u>ADD:</u> Page 6-7	F1	2110-0001	FUSE 1A
Page 6-7	F1	2110-0002	FUSE 2A 250V
Page 6-44	A13C102	0160-4209	C-FXD .01UF 20% 50VDC

<u>DELETE:</u> Page 6-7	J5	
Page 6-7	MP19	
Page 6-9,6-40	A2 DS2,3	5040-6011
Page 6-12	A3 U18	
Page 6-42	A11 C409	

Page 6-32, Table of Replaceable Parts List:

ADD: A8 W1 1460-1336 WIREFORM

Page 6-39, Table of Replaceable Parts Opt.002/003:

MP7 08165-00207 PANEL FRONT (STD) should read:
 MP7 08165B00209 PANEL FRONT (For Opt.002 only).

Page 8-44, Service Sheet 2A, Component Locator A8:

In Ref.Des.Table and Grid Location MP A4 should read MP1 A1.

Add: W1 D4

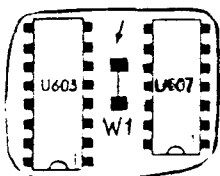

W1 is fitted in Standard Instruments only.

ERRATA (Cont.)

Page 8-69, change the Table 8-3-14 of Driver settings to read :

	Range
line 9	100 MHz - <u>999</u> KHz
line 10	1 MHz - <u>9.99</u> MHz

Page 8-74, Service Sheet 10 :

Add L401 and L406 to Q401 and Q404

On REF DESIG Table below add GRID LOC as follows :

C107 A4
 C502 C5
 CR2 G2
 L401 D8
 L406 D8
 L12 D5
 R266 E10
 R529 B10

Delete: Z1 A/B2

Page 8-103, Service Sheet 6A :

On U7 signal name pin 14 BIT should read: BIT 9.

Add: W1 as shown below :

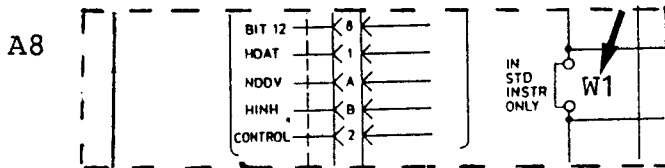

Page 8-114, Table 8-5-2, ROM and data bus signatures :

line 5 D4 pin 14 should read 97A6 36PI

Page 8-121, Service Sheet 8B, P/O A3 BD AY

The value of R21 should read 200

Page 8-133, change Service Sheet 9A to read :

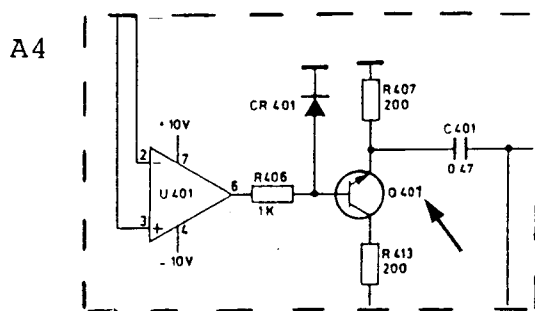

ERRATA (Cont.)

Page 8-136, change the Component Locator and
 Page 8-143 Service Sheet 10 to read :

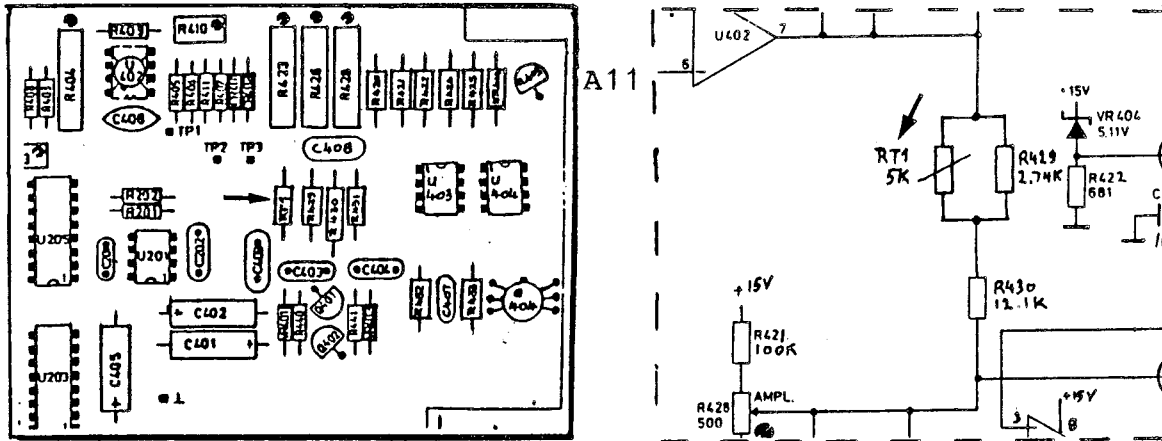

On GRID LOC and REF DESIG Table below :

Add: RT1 I3

Delete: C409 H2
 R427 J2

Page 1-2

Table 1-1 Recommended Test Equipment:

change: Extenderboard from 5060-1742 to 08165-66550.

MANUAL CHANGE 1

On Page 6-7/6-8, change the Table of Replaceable Parts to read :

C3	0160-4048	C-FXD .22UF 250V
MP16	08165-60202	PANEL ASSY REAR
MP28	5040-9330	KEY CAP 0
MP29	5040-9331	KEY CAP 1
MP30	5040-9332	KEY CAP 2
MP31	5040-9333	KEY CAP 3
MP32	5040-9334	KEY CAP 4
MP33	5040-9335	KEY CAP 5
MP34	5040-9336	KEY CAP 6
MP35	5040-9337	KEY CAP 7
MP36	5040-9338	KEY CAP 8
MP37	5040-9339	KEY CAP 9
MP38	5040-9340	KEY CAP .

On Page 6-11 thru 6-16, change the Table of Replaceable Parts to read :

A3R21	0757-0407	R-FXD 200 1% .125W
A4C125*	0160-4031	C-FXD 330PF 5% 100 VDC
A4R120	0698-4432	R-FXD 2.1KOHM 1%.125W
A4R155	0698-3439	R-FXD 178 1% .125W

Add: A4C306,307 0160-0575 C-FXD 47NF \pm 20% 50V

On Page 8-94, change the Component Locator A4 to read :

C306 and C307 are backloaded.

On Page 8-95, change the Service Sheet 4B to read :

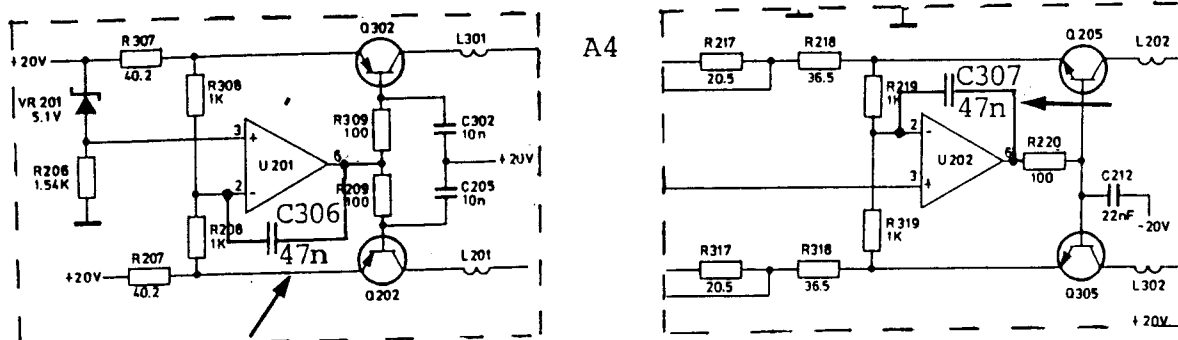

MANUAL CHANGE 1 (Cont.)

On Page 6-17 thru 6-24, change the Table of Replaceable Parts to read :

A5C14	0160-3508	C-FXD 1UF 50V
A5R339	0757-0434	R-FXD 3.65K 1% .125W

Add:	A5C13	0160-3879	C-FXD .01UF + 20%
	A5R530	0757-0467	R-FXD 121K 1% 1.25W

On Page 8-74/75/77, change the Component Locator and Service Sheet 2B/2C to read :

A5

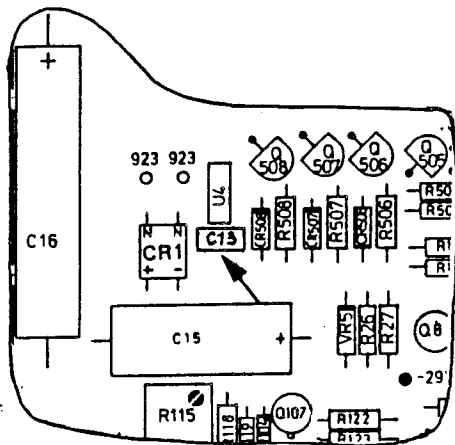

On Grid Location B2 and on REF DESIG Table below add C13

A5

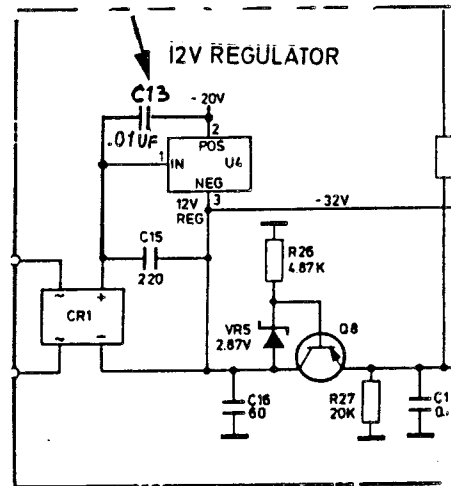

n

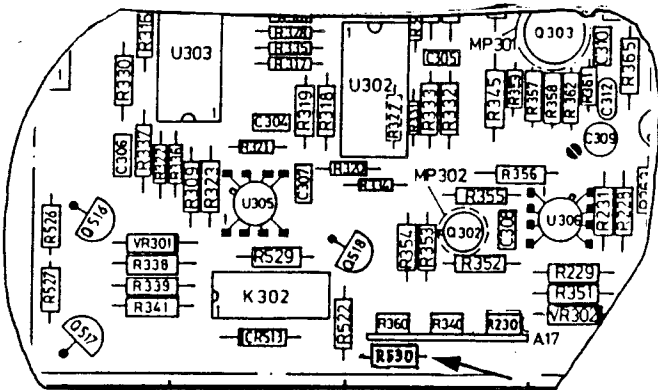

On Grid Location C10 and on REF DESIG Table below add R530

A5

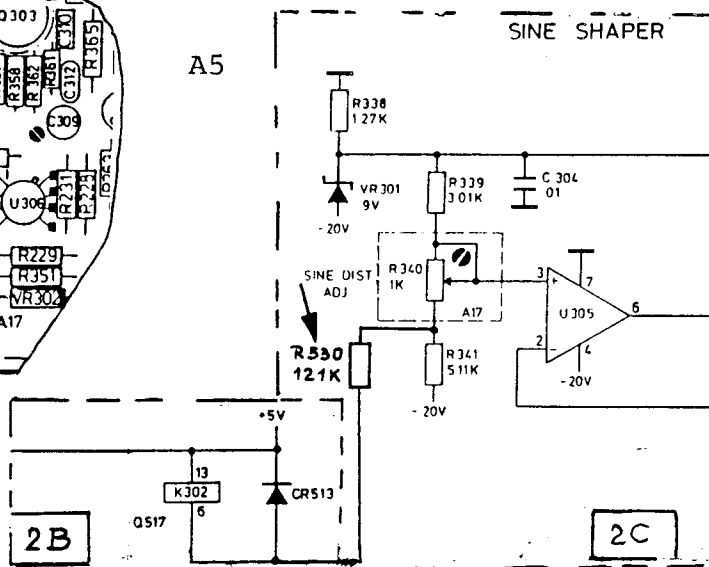

2B

2C

MANUAL CHANGE 1 (Cont.)

On Page 6-31, change the Table of Replaceable Parts to read :

A8C202	Q160-5374	C-FXD .047UF 20%
A8R433*	0683-6855	Factory selected value
A8R436*	0683-1065	Factory selected value

On Page 6-42/6-44, change the Table of Replaceable Parts to read:

A11C101,203	0160-5374	C-FXD .o47UF 20%
A11C403,404		
A11C412	0160-4040	C-FXD 1000PF 100V

Delete: A11CR403,404

Add: A13L301 1970-0029 FERRITE BEAD

On Page 8-79, change the Service Sheet 10 to read :

Short A10 U201 Pin 1 to Pin 2 (Ground).

On Page 8-144/147, change the Component Locator and Service Sheet 11 to read :

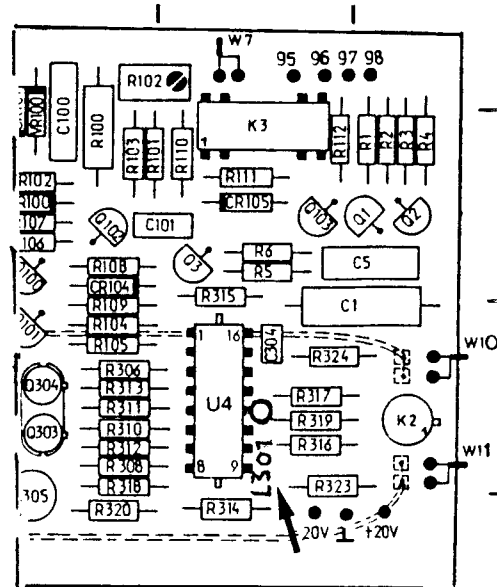
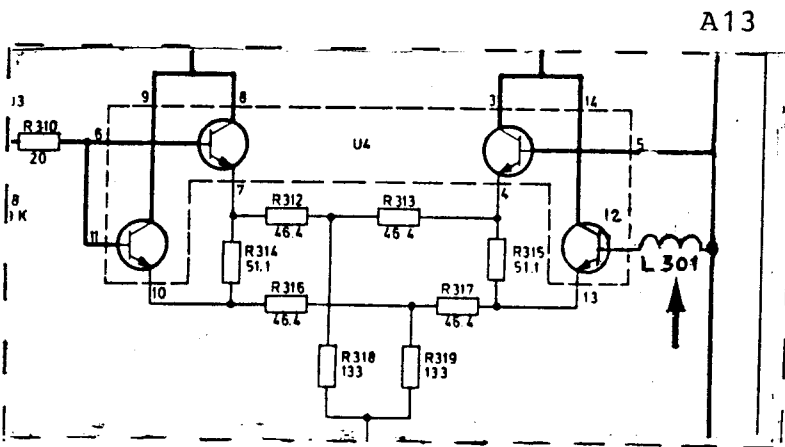

On Grid Location F3 and on REF DESIG Table below add L301

MANUAL CHANGE 2

On Page 6-8, change the Table of Replaceable Parts to read :

MP45	5040-9341	KEY LARGE OLVBG
MP46	5040-9342	KEY LARGE OLVGRY
MP47	5040-9343	KEY LARGE GOLD
A5R341*	0757-0438	R-FXD 5.11KOHM 1% .125W
Add:	A11C102,103	0160-4588
		C-FXD 270PF 5% 100V

On Page 8-136, change the Component Locator of A11 to read :

C102 is backloaded between pin 10 U110 and ground.
 C103 is backloaded between pin 9 U112 and ground.

On Page 8-143, change Service Sheet 10 to read :

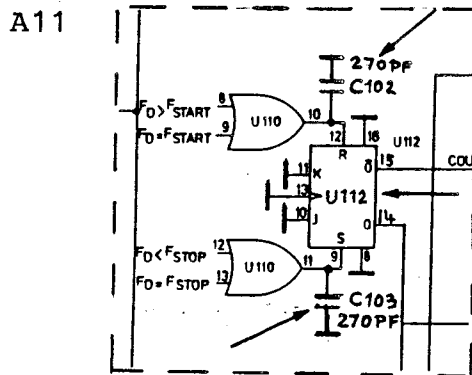

MANUAL CHANGE 3

On Page 6-9/6-17, change the Tables of Replaceable Parts to read :

MP28 thru MP38 } are now parts
 MP45 thru MP47 } of A1 (Exchange Board)

A15	08165-66515	BD AY-RAMP ADJ	} are now parts of A5 (Exchange Board)
A16	08165-66516	BD AY-SOURCES AD	
A17	08165-66517	BD AY-APTD ADJ	

MANUAL CHANGE 4

On Page 6-22, change the Table of Replaceable Parts to read :

A5R302*	0757-0473	R-FXD 221.0K 1% .125W
---------	-----------	-----------------------

MANUAL CHANGE 5

On Page 6-45, change the Table of Replaceable Parts to read :

A13R314,315	0757-0316	R-FXD 42.2 OHM 1%
-------------	-----------	-------------------

MANUAL CHANGE 6

On Page 6-19/20, change the Table of Replaceable Parts to read:

A5Q7,303	1853-0589	XSTR MD4260
----------	-----------	-------------

On Page 6-23, change the Table of Replaceable Parts to read:

A5R359,361	0698-7227	R-FXD 422 1% .05W
------------	-----------	-------------------

MANUAL CHANGE 7

On Page 6-13, change the Table of Replaceable Parts to read:

A4C121	0160-5750	C-FXD 2200PF
--------	-----------	--------------

Delete: A4C113

MANUAL CHANGE 8

On Page 6-13 thru 6-44, change the Table of Replaceable Parts to read:

A4 C110,115,118,
C201,208,501

A5 C 5, 39, 41,
C102,107,202,
C210,212,302,
C303,306,502

0160-5746

C-FXD 0.1UF 20%

A7 C 5

A9 C503
A13C302

MANUAL CHANGE 9

IMPORTANT NOTE: New part numbers assigned to the following items since all threaded holes or screws are now METRIC!

On Page 1-0, Figure 1-2. Available Rack Mounting Accessories, change

Option 907 to read: HP-PART NO. 5061-9689
Option 908 to read: HP-PART NO. 5061-9677
Option 909 to read: HP-PART NO. 5061-9683

On Page 6-7/6-8, change the Table of Replaceable Parts to read:

MP 8	08165-00218	PANEL SUB
MP24	5021-5803	FRAME FRNT 132.6
MP25	5021-5804	FRAME REAR 132.6
MP26	5021-5836	STRUT CRNR 421.6
MP41	5041-6819	CAP STP HNDL FNT
MP42	5041-6820	CAP STP HNDL RR
MP51	5061-9434	COVER TOP 421.6D
MP52	5061-2120	COVER AY BOT 421
MP53	5061-9511	COVER SIDE PERF

On Page 6-39, change the Table of Replaceable Parts to read:

MP8	08165-00218	PANEL SUB
-----	-------------	-----------

MANUAL CHANGE 10

On Page 6-12, change the Table of Replaceable Parts to read:

A3 U24	08165-82901	EPROM 1 32K
A3 U25	08165-82902	EPROM 2 32K
A3 R96	8159-0005	R-FXD 0 Ohms 1% .125W
ADD: A3 J6,7 to U24,25	1200-0541	SKT IC 24Cont

MANUAL CHANGE 11

On Page 6-17, change the Table of Replaceable Parts to read:

A5 C21	0160-5886	C-FXD .02UF 63V 2%
--------	-----------	--------------------

MANUAL CHANGE 12

On Page 6-14, Replaceable Parts List change to read:

A4 CR 3,4,5,6 1901-0673 DIO RECT 100 V 5A

On Page 6-36, Replaceable Parts List change to read:

A10 U14 1820-2864 IC 74F00PC

On Page 6-35, Replaceable Parts List:

ADD: A10 C210 0160-4512 C-FXD 120 PF 5%

On Page 8-79, Schematic:

C210 will be backloaded between
U14 Pin 8 and Pin 7.

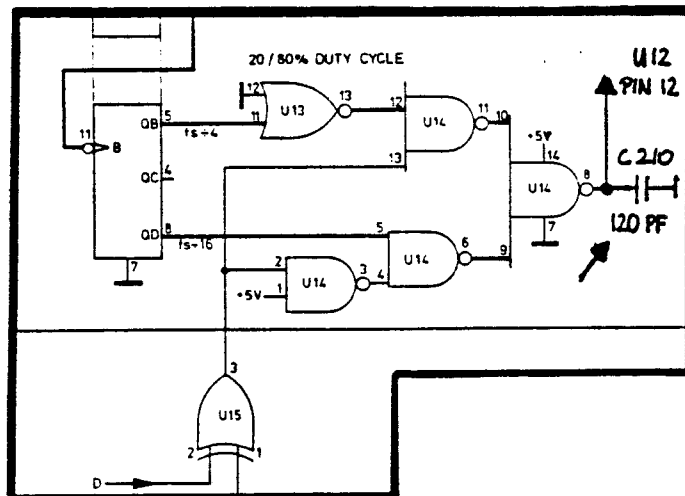

MANUAL CHANGE 13

On Page 6-18, Replaceable Parts List:

ADD: A5 C42 0160-4521 C-FXD 12PF 5% 200V

MANUAL CHANGE 13 (Cont.)

On Page 8-75, Schematic, add:

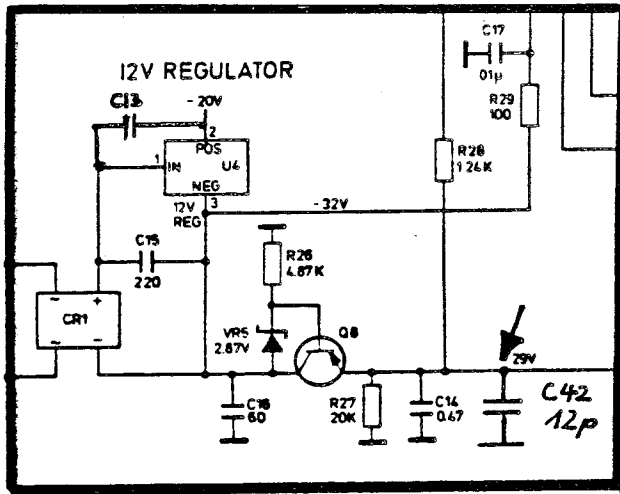

Component Layout: C42 will be backloaded between R27 (-29V) and R506 (Ground).

MANUAL CHANGE 14

On Page 6-9, change the Table of Replaceable Parts to read:

A2	C1,2	0160-4835	C-FXD 1UF 10% 50V
----	------	-----------	-------------------

OPTION 002

On Page 6-40, change the Table of Replaceable Parts to read:

A2	C1,2	0160-4835	C-FXD 1UF 10% 50V
----	------	-----------	-------------------

MANUAL CHANGE 15

On Page 6-20, change the Table of Replaceable Parts to read:

A5	Q21	1854-0215	XSTR SI 2N 3904
----	-----	-----------	-----------------

MANUAL CHANGE 16

On Table 6-3, change the Table of Replaceable Parts to read:

A4	R307,207	0811-2113	R-FXD 40 1% 3W
A4	R218,318	0811-3282	R-FXD 35 5% 3W
A4	R106,105	0811-0988	R-FXD 82 3% 3W
A5	R247	0811-3284	R-FXD 150 5% 3W
A5	R216	0811-1023	R-FXD 225 1% 3W
A5	R217	0698-4441	R-FXD 3.74 KOHM

MANUAL CHANGE 17

On Page 6-22, change the Table of Replaceable Parts to read:

A5	R209	0757-0416	R-FXD 511 1% .125W
----	------	-----------	--------------------

On Page 6-27, change the Table of Replaceable Parts to read:

A6	*R909	0698-3497	R-FXD 6.04K 1%
----	-------	-----------	----------------

MANUAL CHANGE 18

On Table 6-3, change the Table of Replaceable Parts to read:

A4	U201,202		
A5	U6,304,305		
A6	U301,401,501	1820-0493	IC 307N
A8	U202,301		
A9	U207,302,303		

SECTION VII BACKDATING

7-1 INTRODUCTION

7-2 This section contains backdating information which adapts this manual to instrument with serial numbers lower than that shown on the title page.

NOTE: In many earlier instruments, the sweep generator part of the current Option 002 was designated Option 001. Although Option 001 is now obsolete, documentation is provided at the end of this backdating section in the form of a parts list (extra parts for the Frame and Assembly A8, and complete parts list for Assembly A2) and a component layout for Assembly A2. The purpose of this extra documentation is to highlight information not covered under the present option 002 documentation e.g. front panel (MP7 on Frame). The sweep generator board A11 is documented fully under the present Option 002 (Service Sheet 10), there being no difference between the present Option 002 and old Option 001.

7-3 CHANGE SEQUENCE

7-4 Changes are listed in the serial number order that they occurred in the manufacture of the instrument. However, in adapting this manual to an instrument with a particular serial number, apply the changes in reverse order. That is, begin with the latest change and progress to the

earliest change that applies to the serial number in question. Table 7-1 lists the serial numbers to which each change applies.

Table 7-1. Manual Backdating Changes

Instrument Serial Number	Make Manual Changes
1701G00120 and lower	1 to 33
1701G00180 and lower	2 to 33
1701G00220 and lower	3 to 33
1701G00240 and lower	4 to 33
1812G00280 and lower	5 to 33
1812G00320 and lower	6 to 33
1812G00340 and lower	7 to 33
1812G00400 and lower	8 to 33
1812G00420 and lower	9 to 33
1812G00440 and lower	10 to 33
1904G00460 and lower	11 to 33
1904G00480 and lower	12 to 33
1904G00600 and lower	13 to 33
1904G00650 and lower	14 to 33
2005G00790 and lower	15 to 33
2005G00820 and lower	16 to 33
2005G00850 and lower	17 to 33
2005G00910 and lower	18 to 33
2005G00970 and lower	19 to 33
2005G01030 and lower	20 to 33
2030G01060 and lower	21 to 33
2030G01090 and lower	22 to 33
2030G01180 and lower	23 to 33
2030G01240 and lower	24 to 33
2030G01330 and lower	25 to 33
2030G01420 and lower	26 to 33
2030G01600 and lower	27 to 33
2030G01630 and lower	28 to 33
2030G01810 and lower	29 to 33
2030G01870 and lower	30 to 33
2030G01900 and lower	31 to 33
2248G01930 and lower	32 to 33
2248G01960 and lower	33

CHANGE 1 For serial numbers 1701G00120 and lower

On Table 6-3, change the Table of Replaceable Parts to read:

A2R1 thru 4	0698-4381	R-F 48.7 1 % .125
A3C22	0180-0197	C-F 2.2 UF 20 V
A3R88	0757-0465	R-F 100 K 1 %
A5Q107	1854-0354	XSTR SI NPN

Alter the schematic and component layout diagrams in accordance with the above changes.

CHANGE 2 For serial numbers 1701G00180 and lower

On Table 6-3, change the Table of Replaceable Parts to read:

A5R216	0757-0809	R-F 332 1 %
A5R217	0698-3558	R-F 4.02 K 1 %
A5C33	0160-1740	C-F 47 UF 6 V
A5C12	0160-4386	C-F 33 PF 200 V
A5C36	0160-3879	C-F .01 UF 100 V
A14U6, U9	1820-1199	IC SN 74L305

Delete:

A5CR2	1901-0050	DIODE
A5C9	0160-3878	C-F .001 UF 1000 V
A5L2	9170-0029	BEAD FER.
A5MP202	1205-0037	HEAT SINK
J7, 8, 9	1250-0118	BNC CONN
W8	08165-61608	CBL REAR PANEL

Alter the schematic and component layout diagrams in accordance with the above changes.

CHANGE 3 For serial numbers 1807G00220 and lower

On Table 6-3, change the table of Replaceable Parts to read:

A4C1	0180-0441	C-F .032 F 20 V
------	-----------	-----------------

Delete:

A9C503	0160-0576	C-F .1 UF
--------	-----------	-----------

Alter the schematic and component layout diagrams in accordance with the above changes.

CHANGE 4 For serial numbers 1812G00240 and lower

On Table 6-3, change the Table of Replaceable Parts to read:

MP12	08165-012302	BRACKET (STANDARD)
MP10	08165-01204	BRACKET (OPT. 002)
A6MP1	1205-0274	HEAT SINK
A6C801	0160-2150	C-F 33 PF 300 V

Delete:

A4CR7	1901-0050	DIO SI 80 V
A4CR8	1901-0050	DIO SI 80 V
A4R10	0757-0412	R-F 365 1 %
A4C11	0180-0116	C-F 6.8 UF
A12K2	0490-1079	RELAY REED

Alter the schematic and component layout diagrams in accordance with the above changes. Replace the component layout for A6 (Service Sheet A4) given in Section 8 with the layout given at the end of this backdating section.

CHANGE 5 For serial numbers 1812G00280 and lower

On Table 6-3, change the Table of Replaceable Parts to read:

A5C15	0180-0098	C-F 100 UF
A5C16	0180-0097	C-F 47 UF
A5C206	0180-0374	C-F 10 UF
A5C309	0160-2259	C-F 12 PF
A5C503	0180-1704	C-F 47 UF
A5C506	0180-1714	C-F 330 UF
A5W6	08165-61606	CABLE

Delete:

A3C23	0160-3874	C-F 10 PF
A8U706	1820-1963	IC FF (STANDARD)
A8U607	1820-1747	IC DIG (OPT 002)

Note that A5W6 is connected on the rear side of A5 between U201 pin 2 and J3 pin M.

Alter the schematic and component layout diagrams in accordance with the above changes. Replace the Service Sheets 2A and 2B given in Section 8 with the Service Sheets 2A and 2B given at the end of this backdating section.

CHANGE 6 For serial numbers 1812G00320 and lower

On Table 6-3, change the Table of Replaceable Parts to read:

Delete:

A5R518	0683-1065	R-F 10 M
--------	-----------	----------

Alter the schematic and component layout (Service Sheet 2B) in accordance with the above change.

CHANGE 7 For serial numbers 1812G00340 and lower

On Table 6-3, change the Table of Replaceable Parts to read:

A2R5 thru 8	0698-3155	R-F 4.64 K
A2U1	1820-1199	IC 74LS04

Delete:

A14C6	0160-3455	C-F 470 PF
A14R9	0757-0407	R-F 200

Alter the schematic and component layout diagrams in accordance with the above change.
Regarding A14C6 and A14R9, see Service Note 8165A-4.

CHANGE 8 For serial numbers 1812G00400 and lower

On Table 6-3, change the Table of Replaceable Parts to read:

MP52	5060-9846	COVER BOTTOM
------	-----------	--------------

Delete:

MP55	9222-0608	COVER OP CARD
------	-----------	---------------

CHANGE 9 For serial numbers 1812G00420 and lower

On Table 6-3, change the Table of Replaceable Parts to read:

A5C12	0160-0570	C-F 220 PF
A5R22	0698-4543	R-F 487 K .12 W
A5R23	0698-7203	R-F 42.2 1 %
A8R433	0683-3955	R-F 3.9 M .25 W
A8R436	0698-5844	R-F 4.3 M .25 W

Alter the schematic diagrams in accordance with the above change.

CHANGE 10 For serial numbers 1812G00440 and lower

On Table 6-3, change the Table of Replaceable Parts to read:

A4C302	0160-3879	C-F .01 UF 200 V
--------	-----------	------------------

Alter the schematic diagrams in accordance with the above change.

CHANGE 11 For serial number 1904G00460 and lower

On Table 6-3, change the Table of Replaceable Parts to read:

Delete:

A7CR9	1901-0535	DIO SI 15 V
A7R35	0757-0390	R-F 36.5

Alter the schematic diagram in accordance with the above change and change the component layout diagram (Service Sheet 1) as shown below:

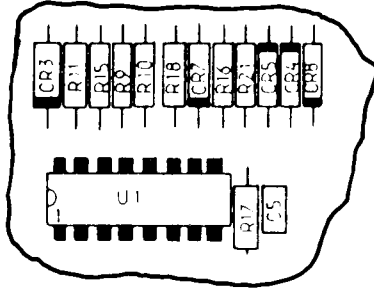

CHANGE 12 For serial numbers 1904G00480 and lower

On Table 6-3, change the Table of Replaceable Parts to read:

A10U2	1820-0261	IC SN 7412IN
-------	-----------	--------------

Alter the schematic and component layout diagrams (Service Sheet 3) as follows:

On the component layout diagram, R1 is now located between U2 and U11 and C1 is now located directly above U2.

On the schematic diagram, R1 is now connected between U2 pin 11 and +5 V and C1 is connected between U2 pin 10 and 11.

CHANGE 13 For serial numbers 1904G00600 and lower

On Figure 6-1 Mainframe: Parts Identification, delete the insulators (MP60x6) from the 3 rear panel BNC connectors OUTPUT, SYNC OUT, EXT INP.

CHANGE 14 For serial numbers 1904G00650 and lower

On Table 6-3, change the Table of Replaceable Parts to read:

A9R205	0757-0274	R-FXD 1.21 K 1 %
Delete:		
A9C206	0160-0571	C-FXD 470 PF

Alter the schematic and component layout diagrams in accordance with the above changes.

CHANGE 15 For serial numbers 2005G00790 and lower

On Table 6-3, change the Table of Replaceable Parts to read:

A6R515	0698-0083	R-FXD 1.96 K 1 % .125 W
A6R516	2100-3351	R-TRMR 500 10 %
A6R520	0757-0439	R-FXD 6.81 K 1 % .125 W
MP7	08165-00202	PANEL, FRONT
MP8	08165-00203	PANEL, SUB

Add:

J1, 2, 3	1250-0118	CONNECTOR BNC FEM 8GL-HOLE 50 OHM
J7, 8, 9	1250-0118	CONNECTOR BNC FEM 8GL-HOLE 50 OHM
W8	08165-61608	CABLE, REAR PANEL

On Table 6-3 (Blue Print) make the following changes:

MP7	08165-00209	PANEL, FRONT (OPT. 002)
-----	-------------	-------------------------

Delete:

W14	08165-61614	CABLE AY REAR EXT INP (OPT 003)
W15	08165-61615	CABLE AY REAR SYNC OUTP (OPT 003)
W16	08165-61616	CABLE AY REAR OUTP (OPT 003)

Page 1-4, Table 1-2 Specifications: Delete: Option 003 REAR PANEL I/O

Alter the following in accordance with the above changes: Figures 5-11 and 6-1, the schematic and component layout diagrams.

CHANGE 16 For serial numbers 2005G00820 and lower

On Table 6-3, change the Table of Replaceable Parts to read:

A9R213	0698-3558	RESISTOR 4.02 K 1 % .125 W
--------	-----------	----------------------------

Alter the schematic diagram in accordance with the above change.

CHANGE 17 For serial numbers 2005G00850 and lower

On Table 6-3, change the Table of Replaceable Parts to read:

A5R40	0757-0476	RESISTOR 301 K 1 % .125 W
A5R50	0698-3437	RESISTOR 133 1 % .125 W
A8VR301	1902-3105	DIODE-ZNR 5.62 V 2 %

Alter the schematic diagrams in accordance with the above change.

CHANGE 18 For serial numbers 2005G00910 and lower

On Table 6–3, change the Table of Replaceable Parts to read:

A2DS10 to 20	1990–0487	LED–VISIBLE
A2DS29 to 31	1990–0487	LED–VISIBLE
(Table 6–3 Blue Print)		
A2DS8 to 31	1990–0487	LED VISIBLE

Alter the schematic diagrams in accordance with the above change.

CHANGE 19 For serial numbers 2005G00970 and lower

On Table 6–3, change the Table of Replaceable Parts to read:

A8R302	0698–4483	RESISTOR 18.7 K 1 % .125 W
A8R303	0698–3268	RESISTOR 11.5 K 1 % .125 W

Alter the schematic diagrams in accordance with the above change.

CHANGE 20 For serial numbers 2005G01030 and lower

On Table 6-3, change the Table of Replaceable Parts to read:

A3	08165-66503	BD AY PROCESSOR
Add:		
A3U23	1818-0364	IC NMOS 16384-BIT ROM
A3U24	1818-0362	IC NMOS 16384-BIT ROM
A3U25	1818-0363	IC NMOS 16384-BIT ROM
A3U26	1818-0361	IC NMOS 16384-BIT ROM
Delete:		
A3R96	0757-0280	RESISTOR 1 K 1 % .125 W

Alter Figure 8-5-1, 8, 9 & Table 8-5-1, 2 as shown on the included figures and replace the component layout and schematic diagrams for A3 (Service Sheets 8A and 8B) in Section 8 with the diagrams given at the end of this backdating section.

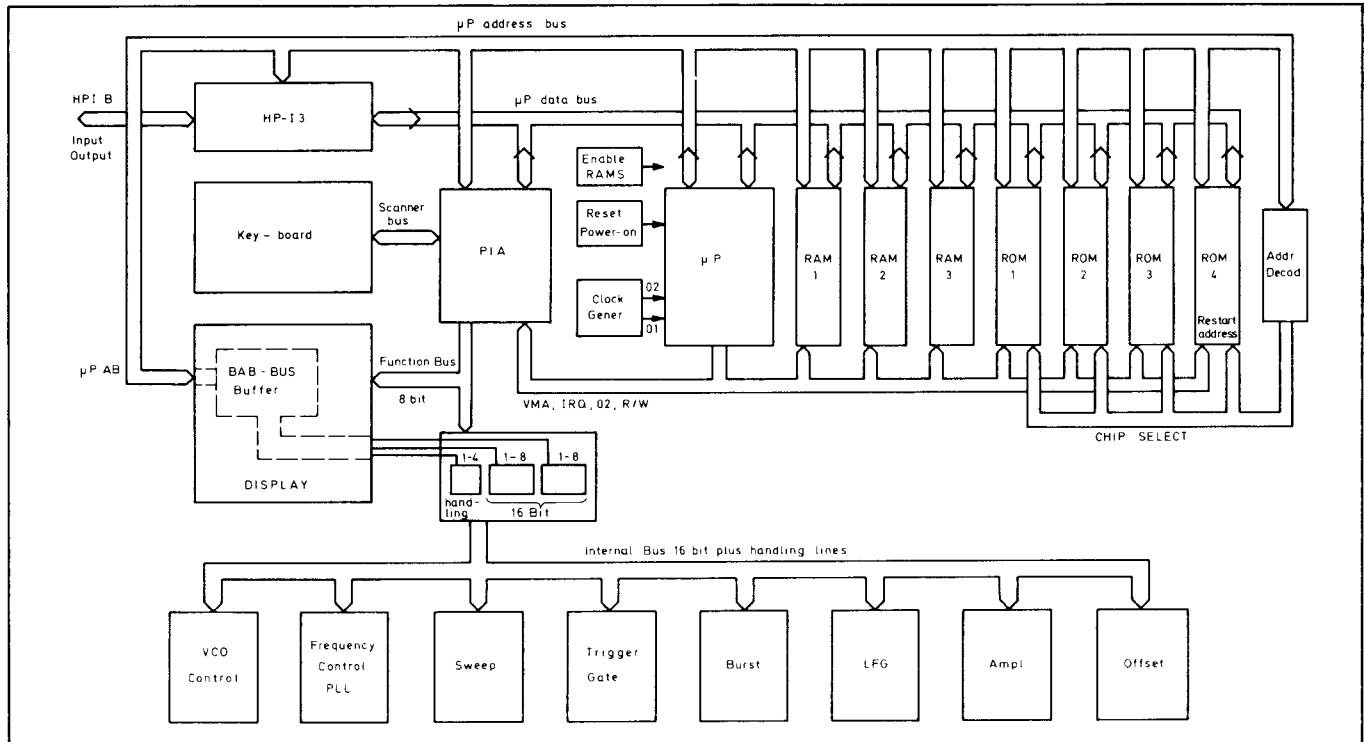

Figure 8-5-1. Controller Block Diagram

CHANGE 20 continued

a. Address Bus Test (free run routine)

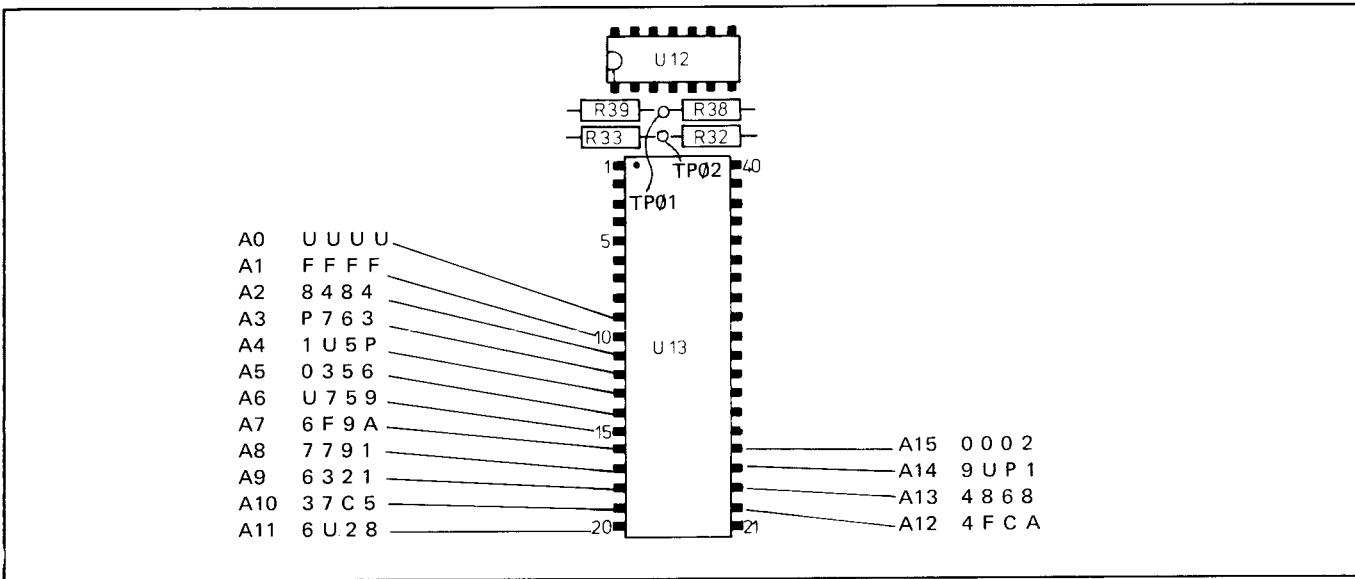
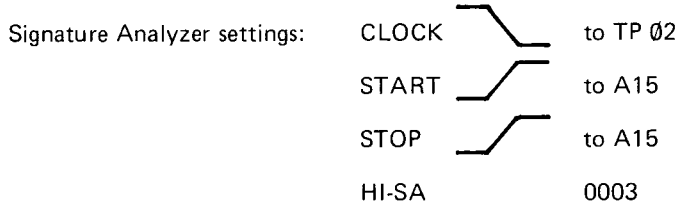

Figure 8-5-7. Address bus signatures

b. Address Decoder Test (same settings as previous test)

Table 8-5-1. Address decoder signatures

U15 pin	4	7 5 5 H
	7	P A C H
	9	5 0 0 8
	10	8 7 8 P
	11	0 7 3 C
	12	3 A 0 3
U16	6	7 7 9 2
U17	4	7 7 9 1
	5	7 5 5 H
	6	0 U 5 7
	11	7 A 0 9
U18	1	5 0 0 C
	4	0 7 3 8
	10	8 7 8 H
	13	3 A 0 0

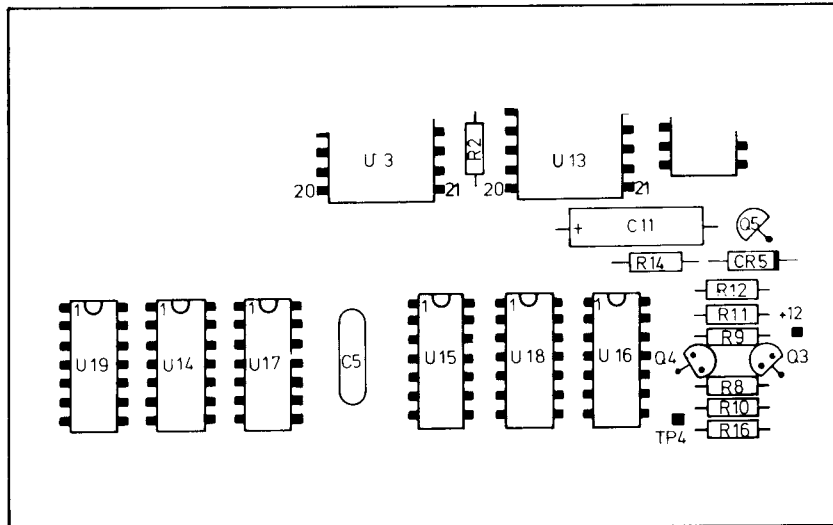
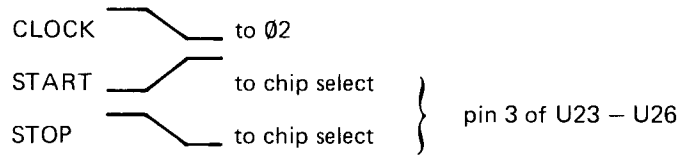

Figure 8-5-8. Address decoder IC's

CHANGE 20 continued

c. ROM and Data Bus Test

Signature Analyzer settings:



RAM U20 contains the information of all stored data (0 - 9)

Table 8-5-2. ROM and data bus signatures

	pin	U23	U24	U25	U26
D0	4	94C5	9568	92HH	5U99
D1	5	7UC4	F658	C088	FAH2
D2	6	6H08	3498	OHHF	8UP2
D3	7	3212	H217	C4H4	276A
D4	19	HH80	84F2	U213	IP2H
D5	18	36C8	UP35	HC10	98U7
D6	17	CAUH	4792	FP4P	A60F
D7	16	F40A	391A	7747	A023

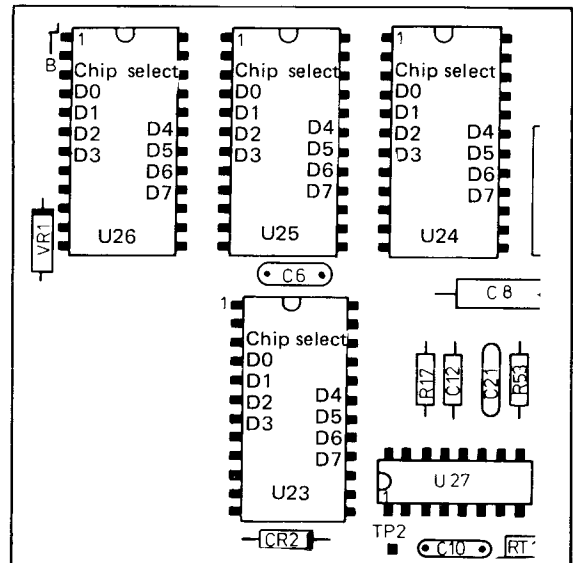

Figure 8-5-9. Data bus IC's

d. Display Troubleshooting

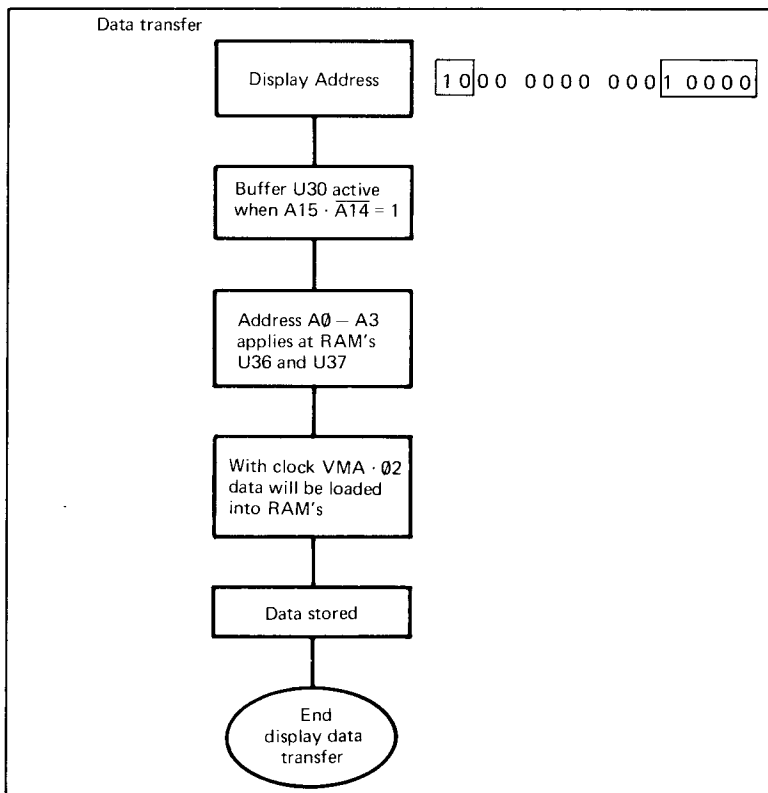

Figure 8-5-10. Display flowchart

CHANGE 21 For serial numbers 2030G01060 and lower

On Table 6-3, change the Table of Replaceable Parts to read:

A14C3, 4, 5 0160-2055 CAPACITOR FXD .01 UF +80, -20 % 100 V

Alter the schematic diagram in accordance with the above change.

CHANGE 22 For serial numbers 2030G01090 and lower

On Table 6-3, change the Table of Replaceable Parts to read:

Delete:

A5R519 0683-1065 RESISTOR 10 M 5 % .25 W

Alter the schematic and component layout diagrams in accordance with the above change.

CHANGE 23 For serial numbers 2030G01180 and lower

On Table 6-3, change the Table of Replaceable Parts to read:

A4MP3 1205-0236 HEAT SINK

Delete:

A5C406

Alter schematic and layout diagrams in accordance with above change.

CHANGE 24 For serial numbers 2030G01240 and lower

On Table 6-3, change the Table of Replaceable Parts to read:

A3U20,21,22 1818-0319 IC CMOS RAM 1K

CHANGE 25 For serial numbers 2030G01330 and lower

On Table 6-3, change the Table of Replaceable Parts to read:

A14S1 3101-1860 SWITCH

CHANGE 26 For serial numbers 2030G01420 and lower

On Table 6-3, change the Table of Replaceable Parts to read:

S1 3101-1720 SWITCH PB DPDT.

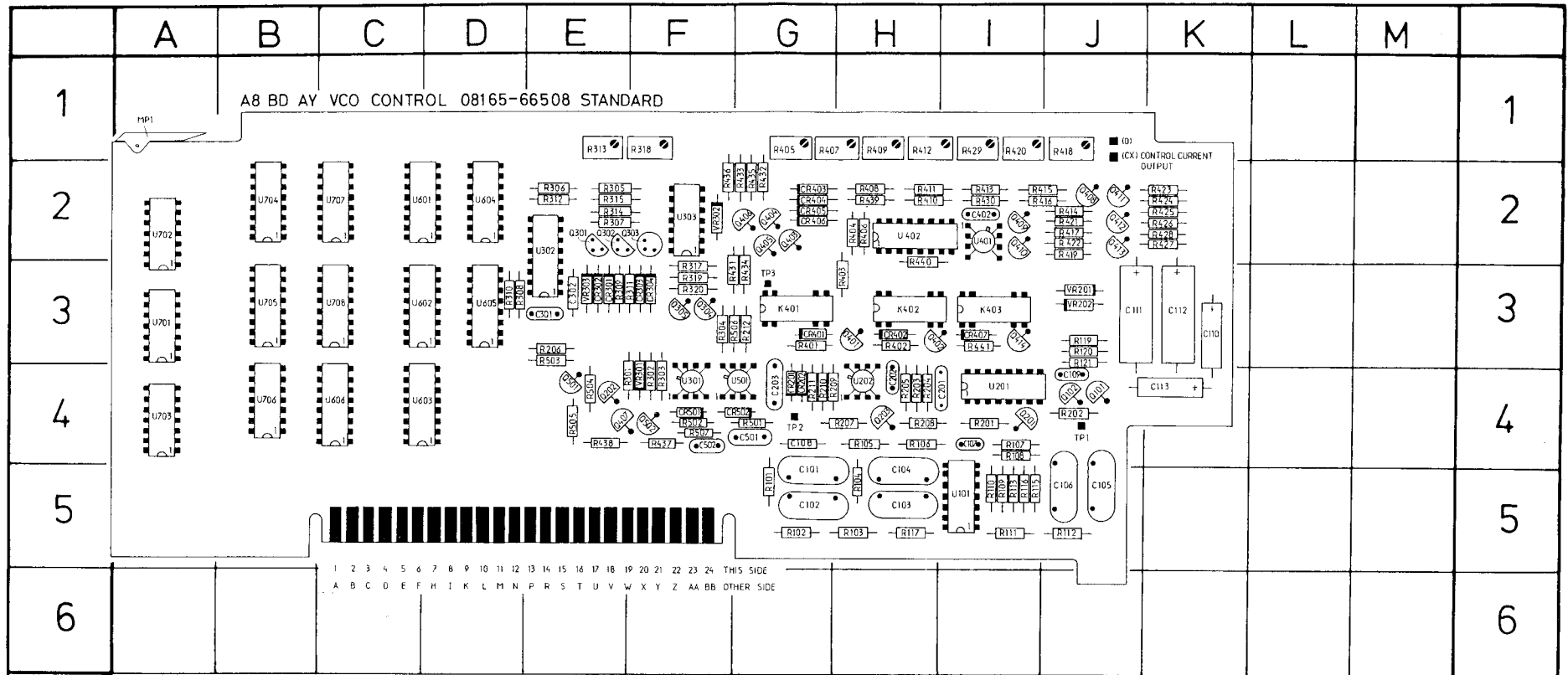

REF DESIG	GRID LOC	REF DESIG	GRID LOC	REF DESIG	GRID LOC	REF DESIG	GRID LOC	REF DESIG	GRID LOC	REF DESIG	GRID LOC	REF DESIG	GRID LOC	REF DESIG	GRID LOC	REF DESIG	GRID LOC								
C101	G5	C203	G4	CR404	G2	Q301	E2	Q411	J2	R108	I4	R204	H4	R307	E2	R203	H3	R418	J1	R433	G2	R506	G3	U605	D3
C102	G5	C301	E3	CR405	G2	Q302	E2	Q411	J2	R109	I5	R205	H4	R308	D3	R204	H2	R419	J2	R434	G3	R507	F4	U606	C4
C103	H5	C302	E3	CR406	G2	Q303	F2	Q412	J2	R110	I5	R206	E3	R309	E3	R405	G1	R420	I1	R435	G2	U101	I5	U701	A3
C104	H5	C402	I2	CR407	I3	Q304	F3	Q412	J2	R111	I5	R207	H4	R310	D3	R406	H2	R421	J2	R436	G2	U201	I4	U702	A2
C105	J5	C501	G4	CR501	F4	Q305	F3	Q413	J2	R112	J5	R208	H4	R311	F3	R407	G1	R422	J2	R437	F4	U202	H4	U703	A4
C106	J5	C502	F4	CR502	G4	Q401	H3	Q414	I3	R113	I5	R209	H4	R312	E2	R408	H2	R423	K2	R438	E4	U301	F4	U704	B2
C107	I4	CR201	G4	K401	G3	Q402	I3	Q501	E4	R115	I5	R210	G4	R313	E1	R409	H1	R424	K2	R439	H2	U302	E2	U705	B3
C108	G4	CR202	G4	K402	H3	Q403	G2	Q502	F4	R116	I5	R211	G4	R314	E2	R410	H2	R425	K2	R440	H3	U303	F2	U706	B4
C109	J4	CR301	E3	K403	I3	Q404	G2	R101	G5	R117	H5	R212	G3	R315	E2	R411	H2	R426	K2	R441	I3	U401	I2	U707	C2
C110	K3	CR302	E3	MP2		Q405	G2	R102	G5	R119	J3	R301	F4	R317	F3	R412	H1	R427	K2	R501	G4	U402	H2	U708	C3
C111	J3	CR303	F3	Q101	J4	Q406	G2	R103	H5	R120	J3	R302	F4	R318	F1	R413	I2	R428	K2	R502	F4	U501	G4	VR201	J3
C112	K3	CR304	F3	Q102	J4	Q407	E4	R104	H5	R121	J3	R303	F4	R319	F3	R414	J2	R429	I1	R503	E4	U601	D2	VR202	J3
C113	K4	CR401	G3	Q201	I4	Q408	J2	R105	H4	R201	I4	R304	F3	R320	F3	R415	J2	R430	I2	R504	E4	U602	D3	VR301	F4
C201	I4	CR402	H3	Q202	E4	Q409	I2	R106	H4	R202	J4	R305	E2	R401	G3	R416	J2	R431	G3	R505	E4	U603	D4	VR302	F2
C202	H4	CR403	G2	Q203	H4	Q410	I2	R107	I4	R203	H4	R306	E2	R402	H3	R417	J2	R432	G2	R505		U604	D2	VR303	E3

2A

TO U30Z **2A**

030K VIA R308 } **2A**
 030S VIA R310 }

6 } **2A**
 3 }
 2 }
 1 }

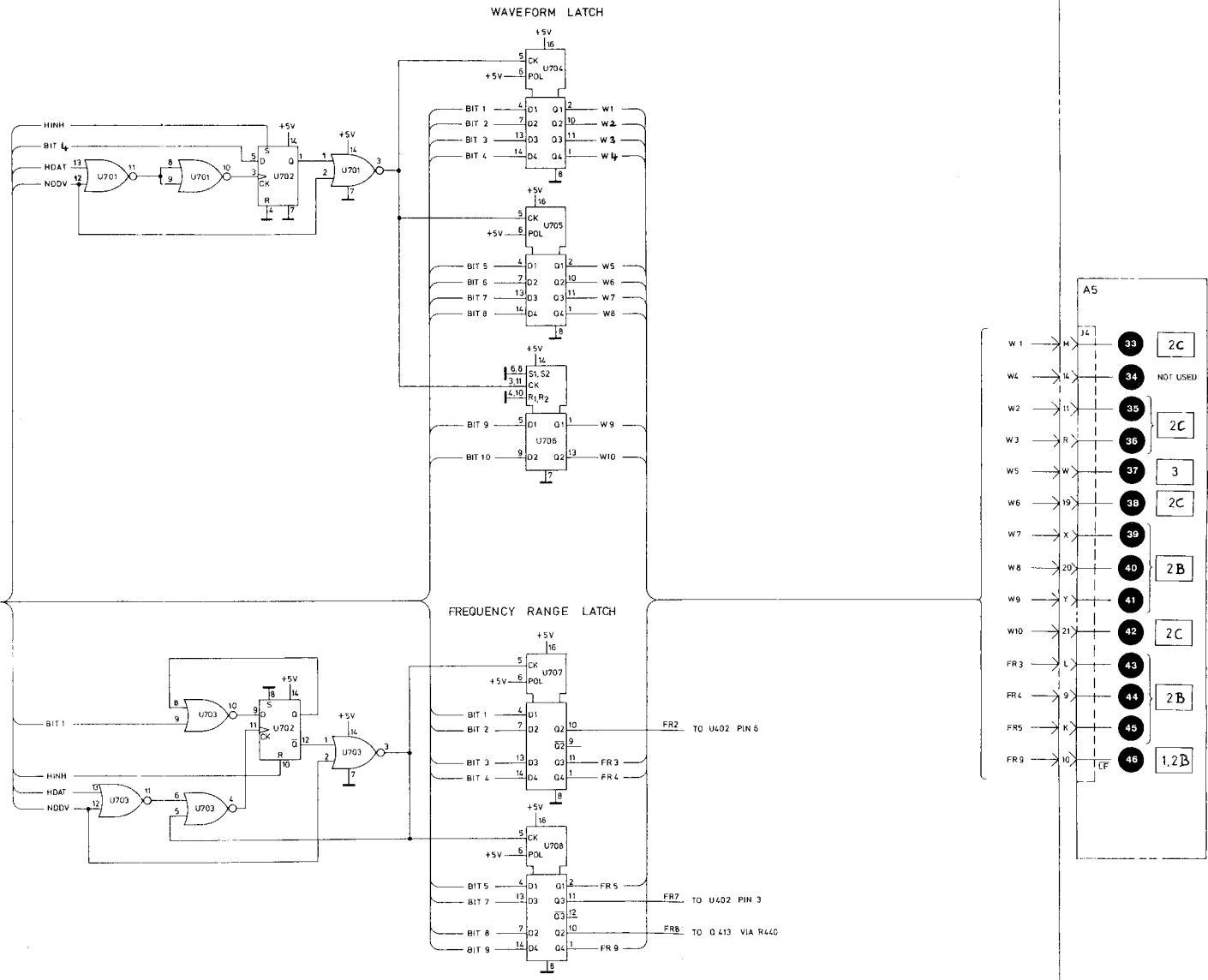

A8
VCO CONTROL

2A

A8 BD AY VCO CONTROL 08165-66508

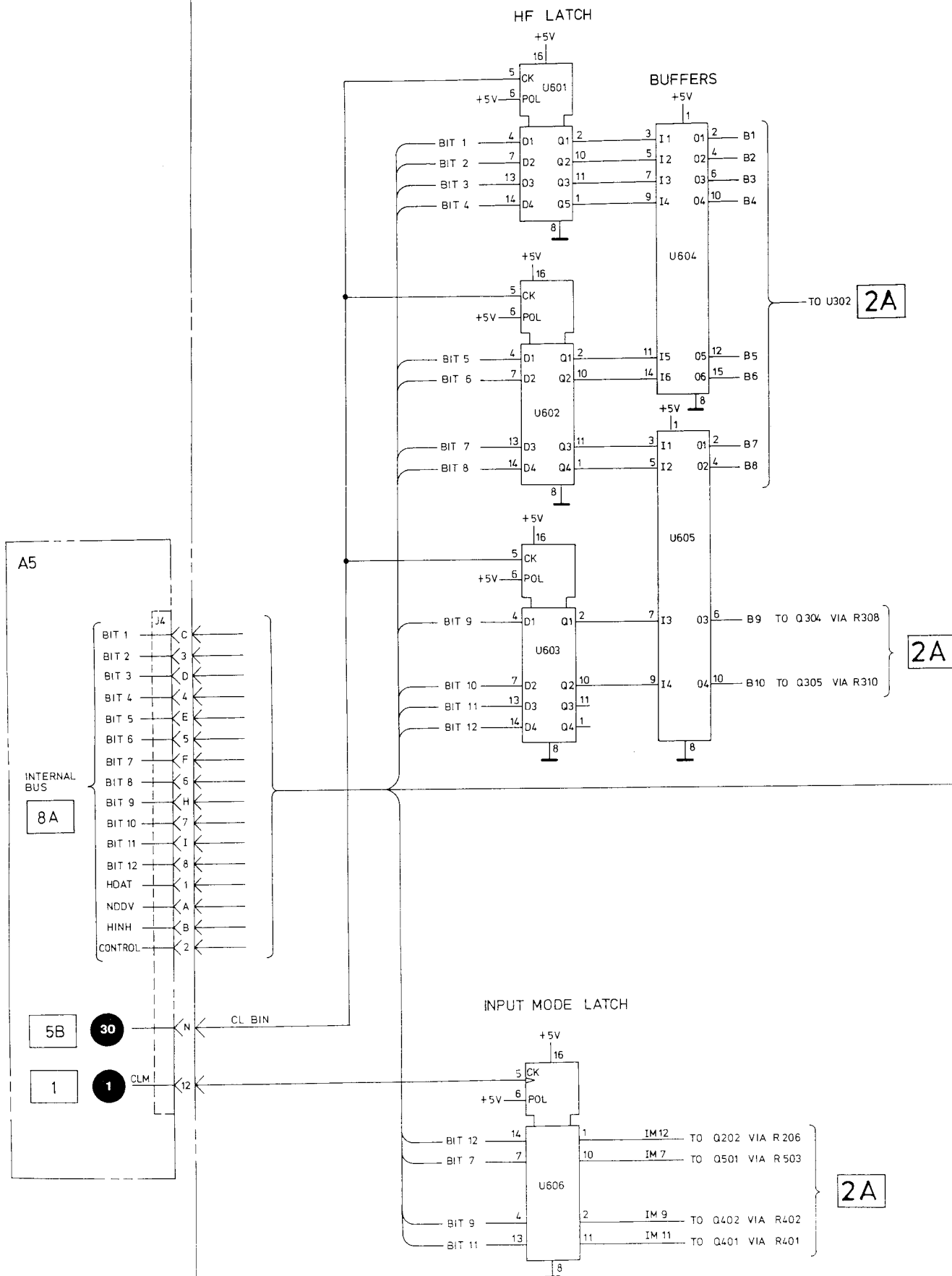

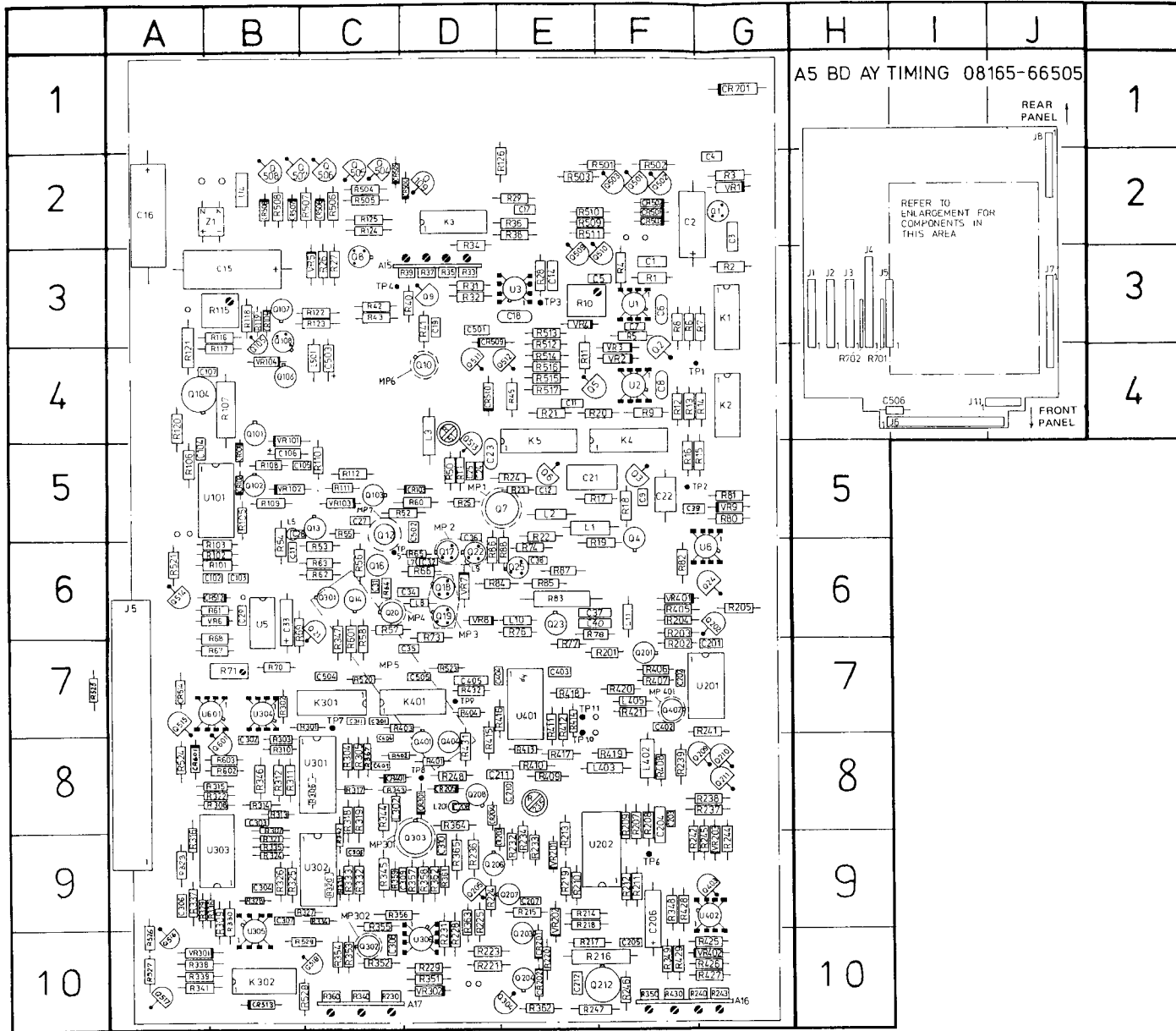

REF DESIG	GRID LOC	REF DESIG	GRID LOC	REF DESIG	GRID LOC
C1	F3	C402	F7	L403	E8
C2	F2	C403	E7	L405	F7
C3	G2	C404	C8	L406	
C4	G2	C405	D7	L501	C4
C5	E3	C501	D3	MP1	D5
C6	F3	C502	D6	MP2	D6
C7	F3	C503	C4	MP3	D6
C8	F4	C504	C7	MP4	C6
C9	F5	C505	D7	MP5	C6
C11	E4	C506	I4	MP6	D4
C12	E5	CR101	B5	MP7	C5
C14	E3	CR102	B5	MP301	D8
C15	B3	CR103	D5	MP302	C10
C16	A2	CR104	B3	MP401	F7
C17	E2	CR201	E10	Q1	G2
C18	E3	CR202	E10	Q2	F4
C19	D3	CR203	D8	Q3	F5
C21	E5	CR204	D8	Q4	F5/6
C22	F5	CR205	D8	Q5	E4
C23	D5	CR301	D8	Q6	E5
C24	D5	CR401	C8	Q7	D5
C25	D5	CR501	F2	Q8	C3
C27	C5	CR502	F2	Q9	D3
C28	B5	CR503	F2	Q10	D4
C29	B6	CR504	D2	Q12	C5
C30		CR505	C2	Q13	C5
C31	C6	CR506	C2	Q14	C6
C32	D6	CR507	B2	Q16	C6
C33	B6	CR508	B2	Q17	D6
C34	C6	CR509	D3	Q18	D6
C35	D7	CR510	D4	Q19	D6
C36	D5	CR512	A6	Q20	C6
C38	C6	CR513	B10	Q21	C6
C37	E6	CR514	A7	Q22	D6
C38	E6	CR601	A8	Q23	E6
C39	F5	CR701	G2	Q24	G6
C40	E6	J1	H3	Q25	E6
C41	B6	J2	H3	Q101	B4
C101	B6	J3	H3	Q102	B5
C102	A6	J4	H3	Q103	C5
C103	B6	J5	A7	Q105	B4
C104	A5	J6	I4	Q106	B4
C105	B5	J7	J3	Q107	B3
C106	B5	J8	J2	Q108	B3
C107	J1	J11	J4	Q109	D2
C201	G7	K1	G3	Q201	F7
C202	F7	K2	G4	Q202	G6
C203	F8	K3	D2	Q203	E10
C204	F8	K4	F4	Q204	E10
C205	F10	K5	E4	Q205	D8
C206	F9	K301	C7	Q206	D9
C207	E9	K302	B10	Q207	E9
C208	D8	K401	C7	Q208	D8
C210	E8	L1	E5	Q209	G8
C211	D8	L2	E5	Q210	G8
C212	E10	L3	E6	Q211	G8
C301	C7	L5	B5	Q212	E10
C302	B8	U7	D6	Q301	C6
C303	B8	L8	D6	Q302	C10
C304	B9	L9	D6	Q303	D8
C305	C9	L10	E6	Q304	E10
C306	A9	L11	F6	Q401	D8
C307	B9	L201	D8	Q402	F7
C308	C10	L301		Q403	G9
C310	D9	L302	C8	Q404	D8
C311	C7	L401		Q501	F2
C401	C8	L402	F8	Q502	F2

2B

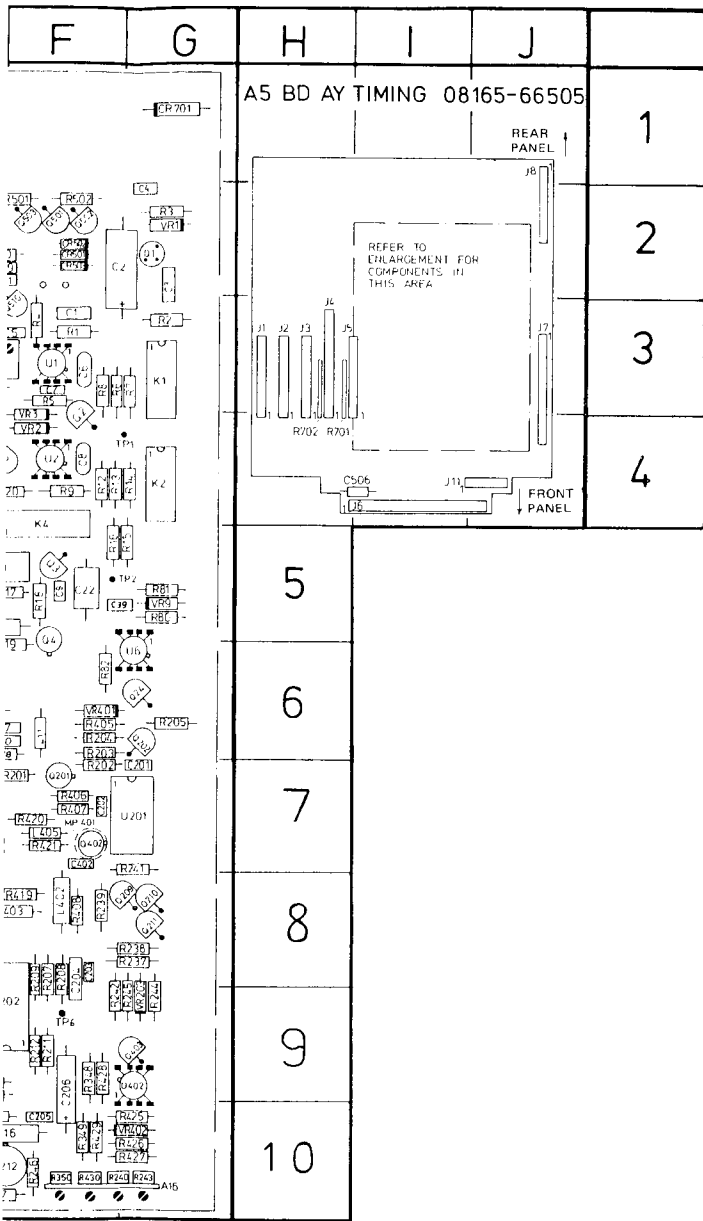

REF DESIG	GRID LOC	REF DESIG	GRID LOC	REF DESIG	GRID LOC	REF DESIG	GRID LOC	REF DESIG	GRID LOC	REF DESIG	GRID LOC	REF DESIG	GRID LOC	REF DESIG	GRID LOC
C1	F3	C402	F7	L403	E8	Q503	F2	R62	C6	R223	D10	R348	F9	R523	D7
C2	F2	C403	E7	L405	F7	Q504	C2	R63	C6	R224	D9	R349	F10	R524	A8
C3	G2	C404	C8	L406		Q505	C2	R64	C6	R225	D9	R351	D10	R525	A7
C4	G2	C405	D7	L501	C4	Q506	C2	R65	D6	R228	D10	R352	C10	R526	A10
C5	E3	C501	D3	MP1	D5	Q507	B2	R66	D6	R229	D10	R353	C10	R527	A10
C6	F3	C502	D7	MP2	D6	Q508	B2	R67	A7	R231	D10	R354	C10	R528	B10
C7	F3	C503	C4	MP3	D6	Q509	E3	R68	A6	R232	E9	R355	C9/10	R601	C6/7
C8	F4	C504	C7	MP4	C6	Q510	E3	R69	B6	R233	F9	R356	C/09	R602	B8
C9	F5	C505	D7	MP5	C6	Q511	D4	R70	B7	R234	E9	R357	D9	R603	B8
C11	E4	C506	I4	MP6	D4	Q512	E4	R71	B7	R235	E8	R358	D9	%701	H3
C12	F5	CR101	B5	MP7	C5	Q513	D4	R73	D7	R236	D9	R359	C9	R702	H3
C14	E3	CR102	B5	MP301	D8	Q514	A6	R74	E6	R237	G8	R361	D9	R11	D5
C15	B3	CR103	D5	MP302	C10	Q515	A7	R76	E6	R238	G8	R362	D9	U1	F3
C16	A2	CR104	B3	MP401	F7	Q516	A10	R77	E7	R239	F8	R362	E10	U2	F4
C17	E2	CR201	E10	Q1	G2	Q517	A10	R78	E6	R241	G7	R363	D9/10	U3	E3
C18	E3	CR202	E10	Q2	F4	Q518	B10	R80	G5	R242	F9	R364	D8	U4	B2
C19	D3	CR203	D8	Q3	F5	Q601	B8	R81	G5	R244	G9	R365	D9	U5	B6
C21	E5	CR204	D8	Q4	F5/6	R1	F3	R82	F6	R245	G9	R367	C8	U6	G6
C22	F5	CR205	D8	Q5	E4	R2	G3	R83	E6	R246	F10	R401	D8	U101	B5
C23	D5	CR301	D8	Q6	E5	R3	G2	R84	D6	R247	E10	R402	C8	U201	G7
C24	D6	CR401	C8	Q7	D5	R4	F3	R85	E6	R248	D8	R403	C/D7	U202	E/F9
C25	D5	CR501	F2	Q8	C3	R5	F3	R86	D6	R301	B7	R404	D7	U301	C8
C27	C5	CR502	F2	Q9	D3	R6	F3	R87	E6	R302	B7	R405	F6	U303	A9
C28	B5	CR503	F2	Q10	D4	R7	G2	R88	D6	R303	B8	R406	F7	U304	B7
C29	B6	CR504	D2	Q12	C5	R8	F3	R101	B6	R304	C8	R407	F7	U305	B9/10
C31	C6	CR505	C2	Q13	C5	R9	F4	R102	A6	R305	C8	R408	F8	U306	D10
C32	D6	CR506	C2	Q14	C6	R10	E3	R103	A6	R306	C8	R409	E9	U401	E7
C33	B6	CR507	B2	Q16	C6	R11	E4	R105	B5	R307	B8	R410	E8	U402	G9
C34	C6	CR508	D3	Q17	D6	R12	F4	R106	A5	R308	B8	R411	E7/8	U601	A/B7
C35	D7	CR510	D4	Q18	D6	R13	F4	R107	B4	R309	B9	R412	E7/8	VR1	G2
C36	D5	CR512	A6	Q19	D6	R14	G4	R108	B5	R310	B8	R413	E8	VR2	F2
C37	E6	CR514	A7	Q20	C6	R15	G5	R109	B5	R311	B8	R414	E7	VR3	F4
C38	E6	CR513	B10	Q21	C6	R16	F5	R110	C5	R312	B8	R415	D8	VR4	E3
C39	F5	CR701	G2	Q22	D6	R17	E5	R111	C5	R313	B8	R416	D/E1	VR5	C3
C40	E6	J1	H3	Q23	E6	R18	F5	R112	C5	R314	B8	R417	E8	VR6	A/B6
C41	B6	J2	H3	Q24	G6	R19	E6	R115	B3	R315	B8	R418	E7	VR7	D6
C101	B6	J3	H3	Q25	E6	R20	E4	R116	B3	R316	A9	R419	F8	VR8	D6
C102	A6	J4	H3	Q101	B4	R21	E4	R117	B4	R317	C8	R420	F7	VR9	G5
C103	B6	J5	A7	Q102	B5	R22	E5	R118	B3	R318	C8	R421	F7	VR101	B4/5
C104	A5	J6	I4	Q103	C5	R23	E5	R119	B3	R319	C8	R425	G10	VR102	B5
C105	B5	J7	J3	Q105	B4	R24	E5	R120	A4	R320	C9	R426	G10	VR103	C5
C106	B5	J8	J2	Q106	B4	R25	D5	R121	A3	R321	B9	R427	G10	VR104	B4
C107	J11	J4	J3	Q107	B3	R26	C3	R122	C4	R322	B8	R428	F9	VR201	E9
C201	G7	K1	G3	Q108	B3	R27	C3	R123	C3	R323	A9	R429	F10	VR202	E9/10
C202	F7	K2	G4	Q109	D2	R28	E3	R124	C3	R324	B9	R431	D8	VR203	G9
C203	F8	K3	D2	Q201	F7	R29	E2	R125	C2	R325	B9	R432	D7	VR301	A10
C204	F8	K4	F4	Q202	G6	R31	D3	R126	D2	R326	B9	R432	D7	VR302	D10
C205	F10	K5	E4	Q203	E10	R32	D3	R201	E7	R327	B9	R501	E/F2	VR401	F6
C206	F9	K301	C7	Q204	E10	R34	D2	R202	F7	R328	B9	R502	F2	VR402	G10
C207	E9	K302	B10	Q205	D9	R36	E2	R203	F6	R329	A9	R503	E2	Z1	A/B2
C208	D8	K401	C7	Q206	D9	R38	E2	R204	F6	R330	B9	R504	C2		
C210	E8	L1	E5	Q207	E9	R40	D3	R205	G6	R331	C9	R505	C2		
C211	D8	L2	E5	Q208	D8	R41	D3	R207	F8	R332	C9	R506	C2		
C212	E10	L3	E6	Q209	G8	R42	C3	R208	F8	R333	C9	R507	B/C2		
C301	C7	L5	B5	Q210	G8	R43	C3	R209	F8	R334	C9	R508	B2		
C302	B8	L7	D6	Q211	G8	R45	E4	R210	F9	R335	B9	R509	E2		
C303	B8	L8	D6	Q212	E10	R50	D5	R211	F9	R336	A/B9	R510	E2		
C304	B9	L9	D6	Q301	C6	R51	D4	R212	F9	R337	A9	R511	E2		
C305	C9	L10	E6	Q302	C10	R52	C5	R213	E8	R338	A10	R512	E3/4		
C306	A9	L11	F6	Q303	D8	R53	C6	R214	E9	R339	A10	R513	E3		
C307	B9	L201	D8	Q304	E10	R54	B5	R215	E9	R341	A10	R514	E4		
C308	C10	L301		Q401	D8	R55	C5	R216	E10	R342	C9	R515	E4		
C310	D9	L302	C8	Q402	F7	R56	C6	R217	E10	R343	C8	R516	E4		
C311	C7	L401		Q403	G9	R57	C6	R218	E9	R344	C8	R517	E4		
C401	C8	L402	F8	Q404	D8	R58	C6	R219	E9	R345	C9	R520	C7		
				Q501	F2	R60	D5	R220	E10	R346	B8	R521	A6		
				Q502	F2	R61	A6	R221	D10	R347	C6/7	R522	B10		

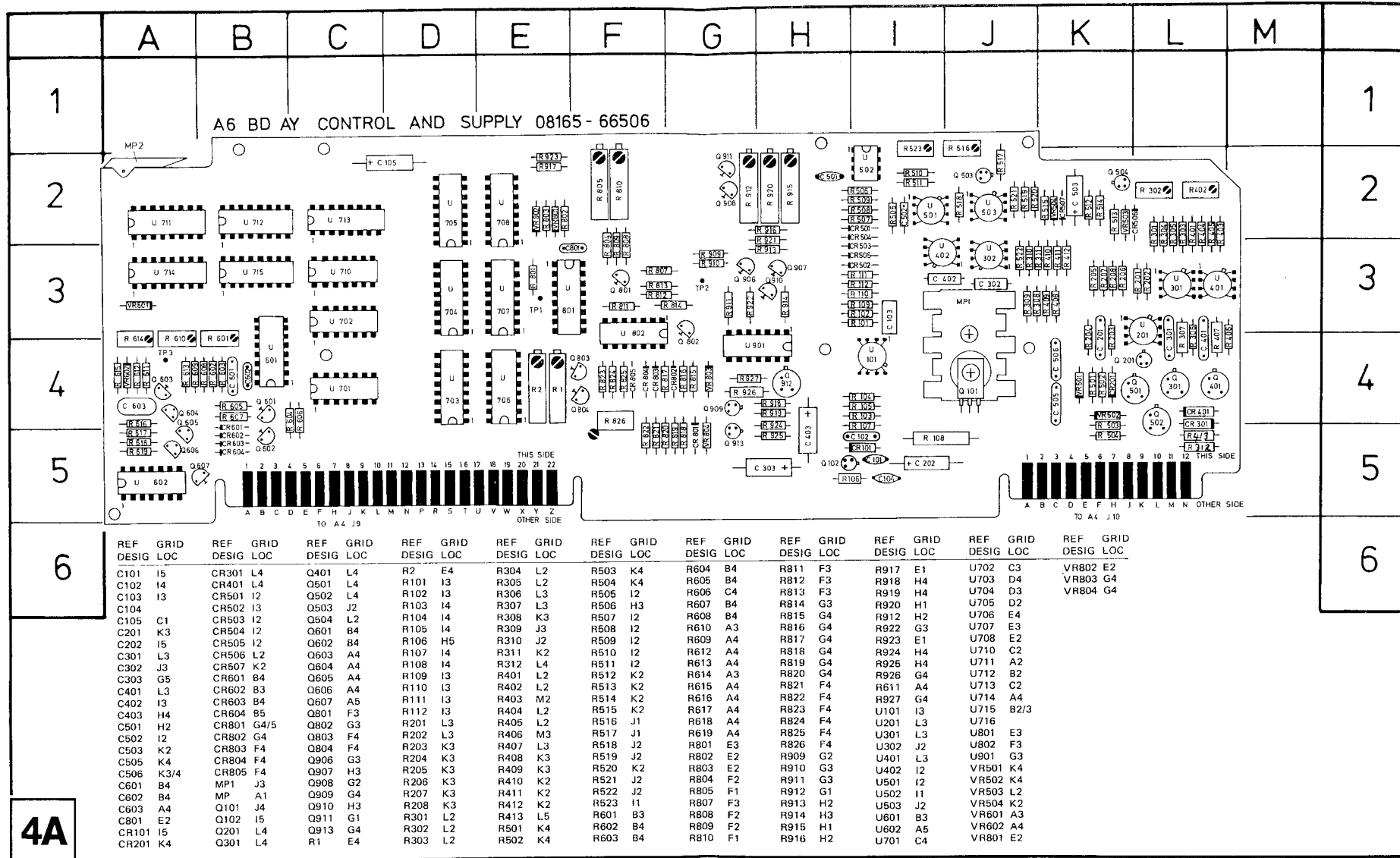

The following parts list and component layout are given here to aid servicing of those earlier instruments with Option 001 fitted:

REFERENCE DESIGNATOR	C H-P PART D NUMBER	DESCRIPTION
A2	3 08165-66518	BD AY DISPLAY
A11	6 08165-66511	BD AY SWEEP GEN
MP7	08165-00204	PANEL FRONT
MP14	1 08165-28102	WINDOW
J6	3 1250-0118	CONN BNC BLKHD
A8CR407	1 1901-0040	DIO SI .06 A 30 V
A8K403	4 0490-1079	RELAY REED
A8 Q414	1 1854-0215	XSTR SI 2N3904
A8R441	4 0757-0439	R-F 6.81K 1 %
A8U607	5 1820-1747	IC CMOS NAND QUD
A2 C1	9 0160-0174	C-F .47UF 25V
A2 C2	9 0160-0174	C-F .47UF 25V
A2 C3	5 0180-1704	C-F 47UF 6V
A2 C4	5 0180-1704	C-F 47UF 6V
A2 DS1	7 1990-0487	LED YEL MIN,DIOD
A2 DS2	7 1990-0487	LED YEL MIN,DIOD
A2 DS3	7 1990-0487	LED YEL MIN,DIOD
A2 DS4	7 1990-0487	LED YEL MIN,DIOD
A2 DS5	7 1990-0487	LED YEL MIN,DIOD
A2 DS6	7 1990-0487	LED YEL MIN,DIOD
A2 DS7	7 1990-0487	LED YEL MIN,DIOD
A2 DS8	7 1990-0487	LED YEL MIN,DIOD
A2 DS9	7 1990-0487	LED YEL MIN,DIOD
A2 DS10	7 1990-0487	LED YEL MIN,DIOD
A2 DS11	7 1990-0487	LED YEL MIN,DIOD
A2 DS12	7 1990-0487	LED YEL MIN,DIOD
A2 DS13	7 1990-0487	LED YEL MIN,DIOD
A2 DS14	7 1990-0487	LED YEL MIN,DIOD
A2 DS15	7 1990-0487	LED YEL MIN,DIOD
A2 DS16	7 1990-0487	LED YEL MIN,DIOD
A2 DS17	7 1990-0487	LED YEL MIN,DIOD
A2 DS18	7 1990-0487	LED YEL MIN,DIOD
A2 DS19	7 1990-0487	LED YEL MIN,DIOD
A2 DS20	7 1990-0487	LED YEL MIN,DIOD
A2 DS21	7 1990-0487	LED YEL MIN,DIOD
A2 DS22	7 1990-0487	LED YEL MIN,DIOD
A2 DS23	7 1990-0487	LED YEL MIN,DIOD
A2 DS24	7 1990-0487	LED YEL MIN,DIOD
A2 DS25	7 1990-0487	LED YEL MIN,DIOD
A2 DS26	7 1990-0487	LED YEL MIN,DIOD
A2 DS27	7 1990-0487	LED YEL MIN,DIOD
A2 DS28	7 1990-0487	LED YEL MIN,DIOD
A2 DS29	7 1990-0487	LED YEL MIN,DIOD
A2 DS30	7 1990-0487	LED YEL MIN,DIOD
A2 DS31	7 1990-0487	LED YEL MIN,DIOD
A2 DS32	5 1990-0485	LED VISIBLE GRN
A2 DS33	8 2140-0016	LAMP INCD 5V.06A
A2 DS34	8 2140-0016	LAMP INCD 5V.06A
A2 DS35	8 2140-0016	LAMP INCD 5V.06A
A2 DS36	8 2140-0016	LAMP INCD 5V.06A
A2 DS37	8 2140-0016	LAMP INCD 5V.06A
A2 DS38	8 2140-0016	LAMP INCD 5V.06A
A2 DS39	8 2140-0016	LAMP INCD 5V.06A
A2 DS40	8 2140-0016	LAMP INCD 5V.06A
A2 DS41	8 2140-0016	LAMP INCD 5V.06A
A2 DS42	8 2140-0016	LAMP INCD 5V.06A
A2 DS43	8 2140-0016	LAMP INCD 5V.06A
A2 DS51	6 1990-0452	LED-DISPLAY
A2 DS52	6 1990-0452	LED-DISPLAY
A2 DS53	6 1990-0452	LED-DISPLAY
A2 DS54	6 1990-0452	LED-DISPLAY
A2 DS55	6 1990-0452	LED-DISPLAY
A2 DS56	6 1990-0452	LED-DISPLAY
A2 DS57	6 1990-0452	LED-DISPLAY
A2 DS58	6 1990-0452	LED-DISPLAY
A2 DS59	6 1990-0452	LED-DISPLAY
A2 DS60	6 1990-0452	LED-DISPLAY
A2 DS61	6 1990-0452	LED-DISPLAY
A2 DS62	6 1990-0452	LED-DISPLAY

REFERENCE DESIGNATOR	C H-P PART D NUMBER	DESCRIPTION
A2 J4	1200-0589	SKT IC 14CONT
A2 J5	1200-0589	SKT IC 14CONT
A2 J6	1200-0589	SKT IC 14CONT
A2 J7	1200-0589	SKT IC 14CONT
A2 J8	1200-0589	SKT IC 14CONT
A2 J9	1200-0589	SKT IC 14CONT
A2 J10	1200-0589	SKT IC 14CONT
A2 J11	1200-0589	SKT IC 14CONT
A2 J12	1200-0589	SKT IC 14CONT
A2 J13	1200-0589	SKT IC 14CONT
A2 J14	1200-0589	SKT IC 14CONT
A2 J15	1200-0589	SKT IC 14CONT
A2 Q1	1 1854-0215	XSTR SI 2N3904
A2 Q2	1 1854-0215	XSTR SI 2N3904
A2 Q3	1 1854-0215	XSTR SI 2N3904
A2 Q4	1 1854-0215	XSTR SI 2N3904
A2 Q5	7 1854-0477	XSTR NPN 2N2222A
A2 Q6	7 1854-0477	XSTR NPN. 2N2222A
A2 R1	8 0757-0706	R-F 51.1 1% .25W
A2 R2	8 0757-0706	R-F 51.1 1% .25W
A2 R3	8 0757-0706	R-F 51.1 1% .25W
A2 R4	8 0757-0706	R-F 51.1 1% .25W
A2 R5	1 0698-3155	R-F 4.64K1%
A2 R6	1 0698-3155	R-F 4.64K1%
A2 R7	1 0698-3155	R-F 4.64K1%
A2 R8	1 0698-3155	R-F 4.64K1%
A2 R9	3 0757-0280	R-F 1K1% .125W F
A2 R10	3 0757-0280	R-F 1K1% .125W F
A2 R11	4 0757-0281	R-F 2.74K1%
A2 R12	4 0757-0281	R-F 2.74K1%
A2 R13	4 0757-0281	R-F 2.74K1%
A2 R14	4 0757-0281	R-F 2.74K1%
A2 R15	1 0698-3155	R-F 4.64K1%
A2 R16	1 0698-3155	R-F 4.64K1%
A2 R17	8 0757-0417	R-F 562 1% .125W
A2 R18	5 1810-0162	R-NETWORK
A2 R19	0 8159-0005	WIRE 22GA W PVC
A2 R20	0 8159-0005	WIRE 22GA W PVC
A2 R21	0 8159-0005	WIRE 22GA W PVC
A2 S1	7 5060-9436	SW P-BTN SINGLE
A2 S2	7 5060-9436	SW P-BTN SINGLE
A2 S3	7 5060-9436	SW P-BTN SINGLE
A2 S4	7 5060-9436	SW P-BTN SINGLE
A2 S5	7 5060-9436	SW P-BTN SINGLE
A2 S6	7 5060-9436	SW P-BTN SINGLE
A2 S7	7 5060-9436	SW P-BTN SINGLE
A2 S8	7 5060-9436	SW P-BTN SINGLE
A2 S9	7 5060-9436	SW P-BTN SINGLE
A2 S10	7 5060-9436	SW P-BTN SINGLE
A2 S11	7 5060-9436	SW P-BTN SINGLE
A2 S12	7 5060-9436	SW P-BTN SINGLE
A2 S13	7 5060-9436	SW P-BTN SINGLE
A2 S14	7 5060-9436	SW P-BTN SINGLE
A2 S15	7 5060-9436	SW P-BTN SINGLE
A2 S16	7 5060-9436	SW P-BTN SINGLE
A2 S17	7 5060-9436	SW P-BTN SINGLE
A2 S18	7 5060-9436	SW P-BTN SINGLE
A2 S19	7 5060-9436	SW P-BTN SINGLE
A2 S20	7 5060-9436	SW P-BTN SINGLE
A2 S21	7 5060-9436	SW P-BTN SINGLE
A2 S22	7 5060-9436	SW P-BTN SINGLE
A2 S23	7 5060-9436	SW P-BTN SINGLE
A2 U1	1 1820-1199	IC SN74LS 04
A2 U2	9 1820-0628	IC SN74 89N
A2 U3	4 1820-0491	IC 74145N
A2 W1	4 5081-1980	CBL RB ILC 279MM
A2 W2	4 5081-1980	CBL RB ILC 279MM
A2 W3	5 5081-1981	CBL RB 26C 305MM

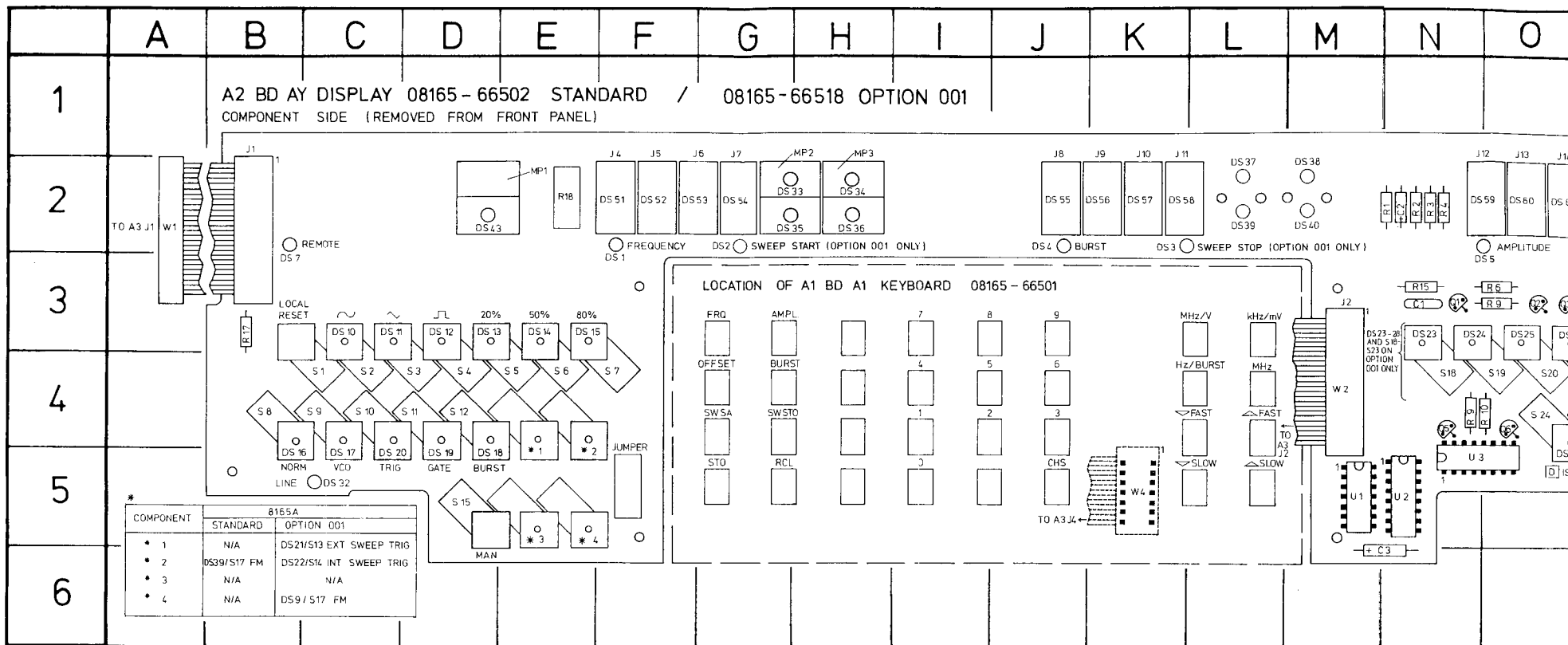

REF DESIG	GRID LOC	REF DESIG	GRID LOC	REF DESIG	GRID LOC	REF DESIG	GRID LOC	REF DESIG	GRID LOC	REF DESIG	GRID LOC	REF DESIG	GRID LOC	REF DESIG	GRID LOC
C1	N3	DS12	D3	DS27	P3	DS42	P2	J2	M3	MP2	G2	R7	P3	S5	E4
C2	N2	DS13	D3	DS28	P3	DS43	D2	J3	O2	MP3	H2	R8	P3	S6	E4
C3	N6	DS14	E3	DS29	D4	DS51	F2	J4	F2	MP4	P2	R9	N4	S7	F4
C4	O4	DS15	E3	DS30	P4	DS52	F2	J5	F2	O1	N3	R10	O4	S8	B4
C5	O4	DS16	B4	DS31	P4	DS53	F2	J6	F2	O2	O3	R11	O3	S9	C4
DS1	F2	DS17	C4	DS32	C5	DS54	G2	J7	G2	O3	O3	R12	O3	S10	C4
DS2	G2	DS18	D4	DS33	G2	DS55	J2	J8	J2	O4	P3	R13	O3	S11	D4
DS3	L2	DS19	D4	DS34	H2	DS56	K2	J9	K2	O5	N4	R14	O4	S12	D4
DS4	J2	DS20	C4	DS35	G2	DS57	K2	J10	K2	O6	O4	R15	N3	S13	C6
DS5	O2	DS21	B6	DS36	H2	DS58	K2	J11	K2	R1	N2	R16	O4	S14	C6
DS6	P2	DS22	B6	DS37	L2	DS59	O2	J12	O1	R2	N2	R17	B3	S15	D5
DS7	B2	DS23	N3	DS38	M2	DS60	O2	J13	O1	R3	N2	S1	C4	S17	E4
DS9	B6	DS24	N3	DS39	L2	DS61	O2	J14	O1	R4	N2	S2	C4	S24	O4
DS10	C3	DS25	O3	DS40	M2	DS62	P2	J15	P1	R5	O3	S3	D4	S25	P4
DS11	C/D3	DS26	O3	DS41	P2	J1	B2	MP1	O2	R6	O3	S4	D4	S26	P4

8D

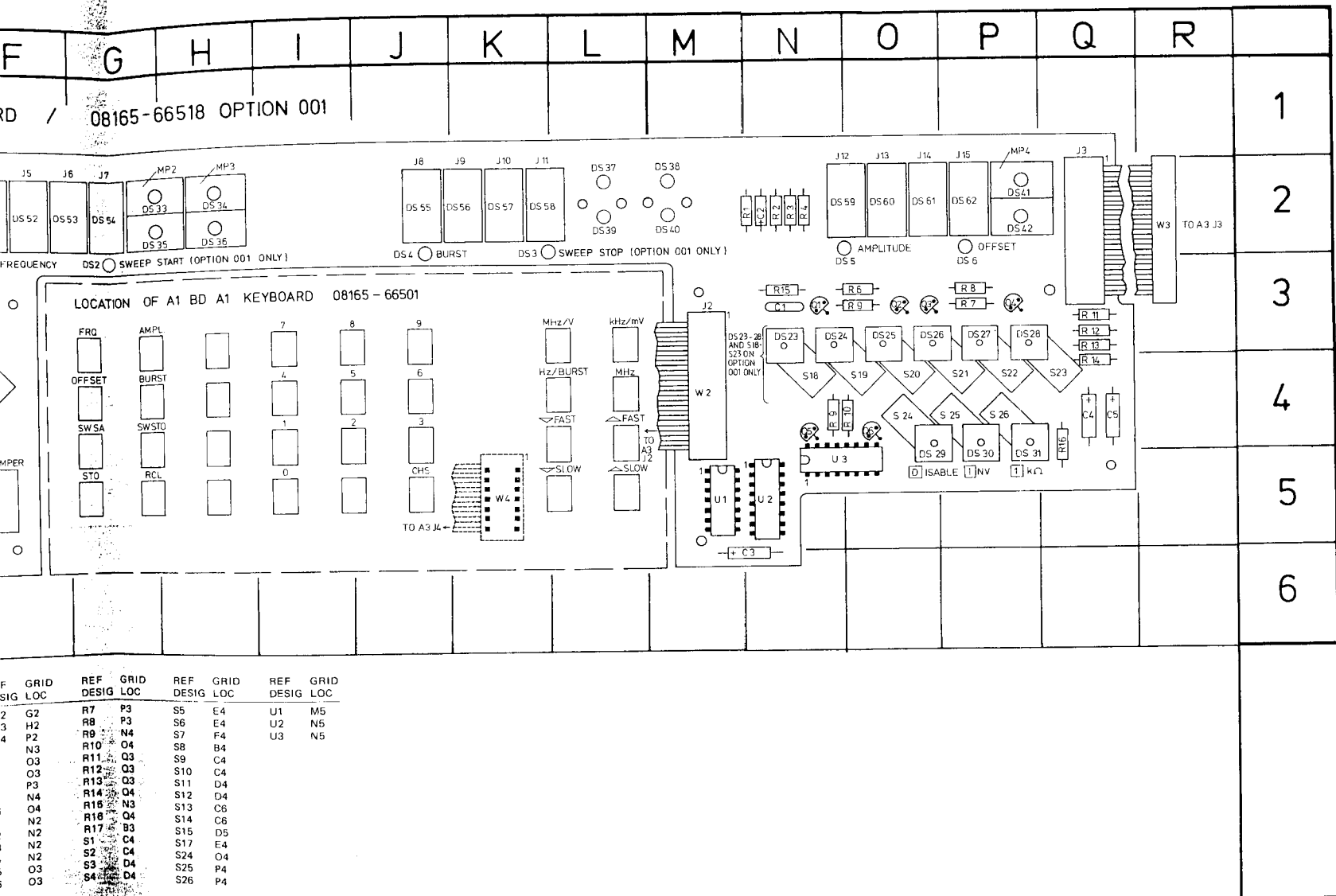

F SIG	GRID LOC	REF DESIG	GRID LOC	REF DESIG	GRID LOC	REF DESIG	GRID LOC
2	G2	R7	P3	S5	E4	U1	M5
3	H2	R8	P3	S6	E4	U2	N5
4	P2	R9	N4	S7	F4	U3	N5
	N3	R10	O4	S8	B4		
	O3	R11	Q3	S9	C4		
	O3	R12	Q3	S10	C4		
	P3	R13	Q3	S11	D4		
	N4	R14	O4	S12	D4		
	O4	R15	N3	S13	C6		
	N2	R16	Q4	S14	C6		
	N2	R17	B3	S15	C6		
	N2	S1	C4	S17	D5		
	N2	S2	C4	S24	O4		
	O3	S3	D4	S25	P4		
	O3	S4	D4	S26	P4		

3 BD AY PROCESSOR 08165 - 66503

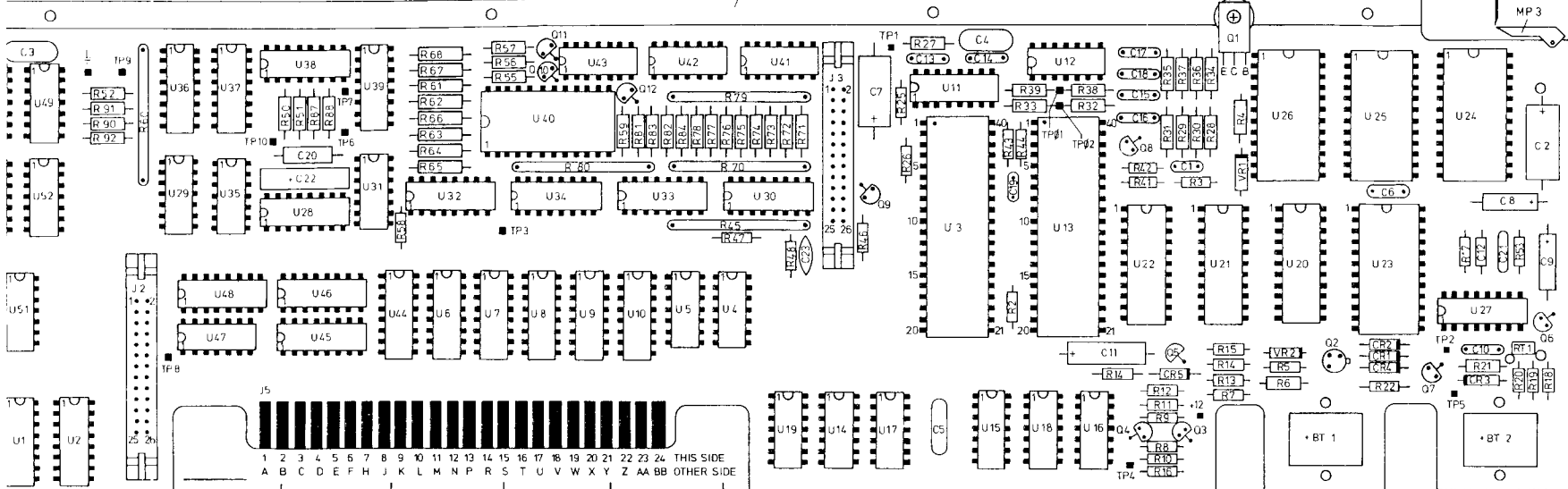

1 2 3 4 5 6 7 8 9 10 11 12 13 14 15 16 17 18 19 20 21 22 23 24 THIS SIDE
 A B C D E F H J K L M N P R S T U V W X Y Z AA BB OTHER SIDE

GRID LOC	REF DESIG	GRID LOC	REF DESIG	GRID LOC	REF DESIG	GRID LOC	REF DESIG	GRID LOC	REF DESIG	GRID LOC	REF DESIG	GRID LOC	REF DESIG	GRID LOC	REF DESIG	GRID LOC	REF DESIG	GRID LOC				
2	J2	C4	Q11	G2	R14	M4	R31	M2	R47	I3	R64	F2	R80	G3	U2	C5	U32	F3	U47	D4	TP1	J2
2	J3	J2	Q12	H2	R15	M4	R32	L2	R48	I3/4	R65	F3	R81	H2	U3	K3	U33	H3	U48	D4	TP2	O4
2	J4	A4	R1	A4/5	R16	M5	R33	K/L2	R50	E2	R66	F2	R82	H2	U4	I4	U34	G3	U49	B2	TP3	G3
2	MP1	M1	R2	K4	R17	P3/4	R34	M2	R51	E2	R67	F2	R83	H2	U5	H4	U35	D3	U50	B2	TP4	L5
2	MP2		R3	M3	R18	P5	R35	M2	R52	C2	R68	F2	R84	H2	U6	F4	U36	D2	U51	B4	TP6	E2
2	Q1	M1	R4	M2	R19	P5	R36	M2	R53	P3/4	R70	H3	R87	E2	U7	F4	U37	D2	U52	B3	TP7	E2
3	Q2	N4	R5	N4	R20	P5	R37	M2	R55	G2	R71	I2	R88	E2	U8	G4	U38	E2	U53	B4	TP8	D4
3	Q3	M5	R6	N5	R21	P5	R38	L2	R56	G2	R72	I2	R90	C2	U9	G4	U39	E2	U54	B3	TP9	C2
3	Q4	M5	R7	M5	R22	O5	R39	K/L2	R57	G2	R73	I2	R91	C2	U10	H4	U40	G2	U55	A2	TP10	D2
3	Q5	N5	R8	M5	R25	J2	R41	L/M3	R58	F3	R74	I2	R92	C2	U11	K2	U41	I2	U56	A3		
3	Q6	P4	R9	M5	R26	J2/3	R42	L/M3	R59	H2	R75	I2	R93	A2	U12	L2	U42	H/12	VR1	M3		
4	Q7	O5	R10	M5	R27	J/K2	R43	K	R60	C2	R76	I2	R94	A2	U13	L3	U43	G/H2	VR2	N4		
4	Q8	L2	R11	M5	R28	M2	R44	K2	R61	F2	R77	I2	R95	A2	U14	J5	U44	F4				
4	Q9	J3	R12	M5	R29	M2	R45	H/13	R62	F2	R78	H2	RT1	P4	U15	K5	U45	E4				
4	Q10	G2	R13	M5	R30	M2	R46	J3	R63	F2	R79	H2	U1	B5	U16	I5	U46	E4				

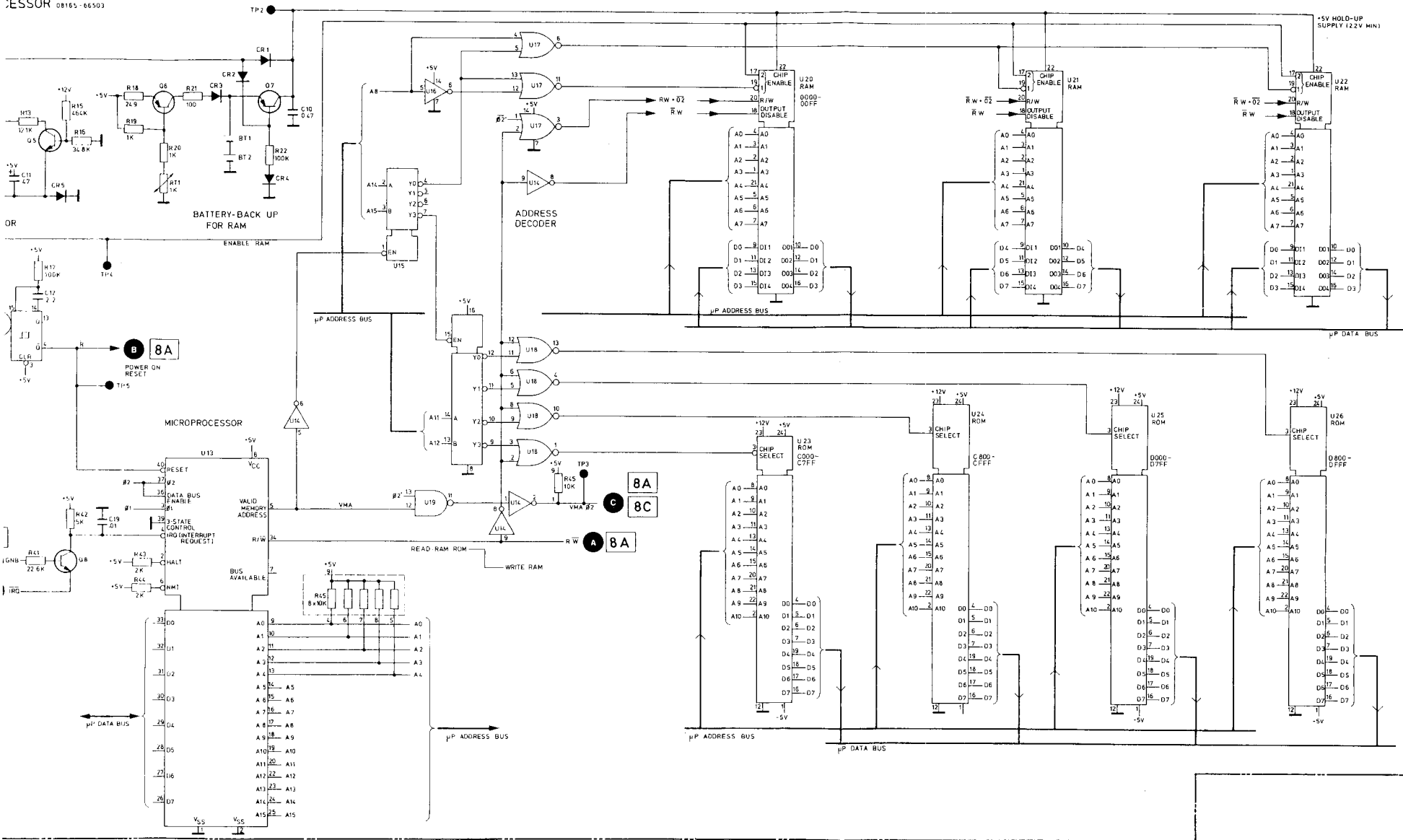

A3 MICROPROCESSOR AND MEMORY

8B

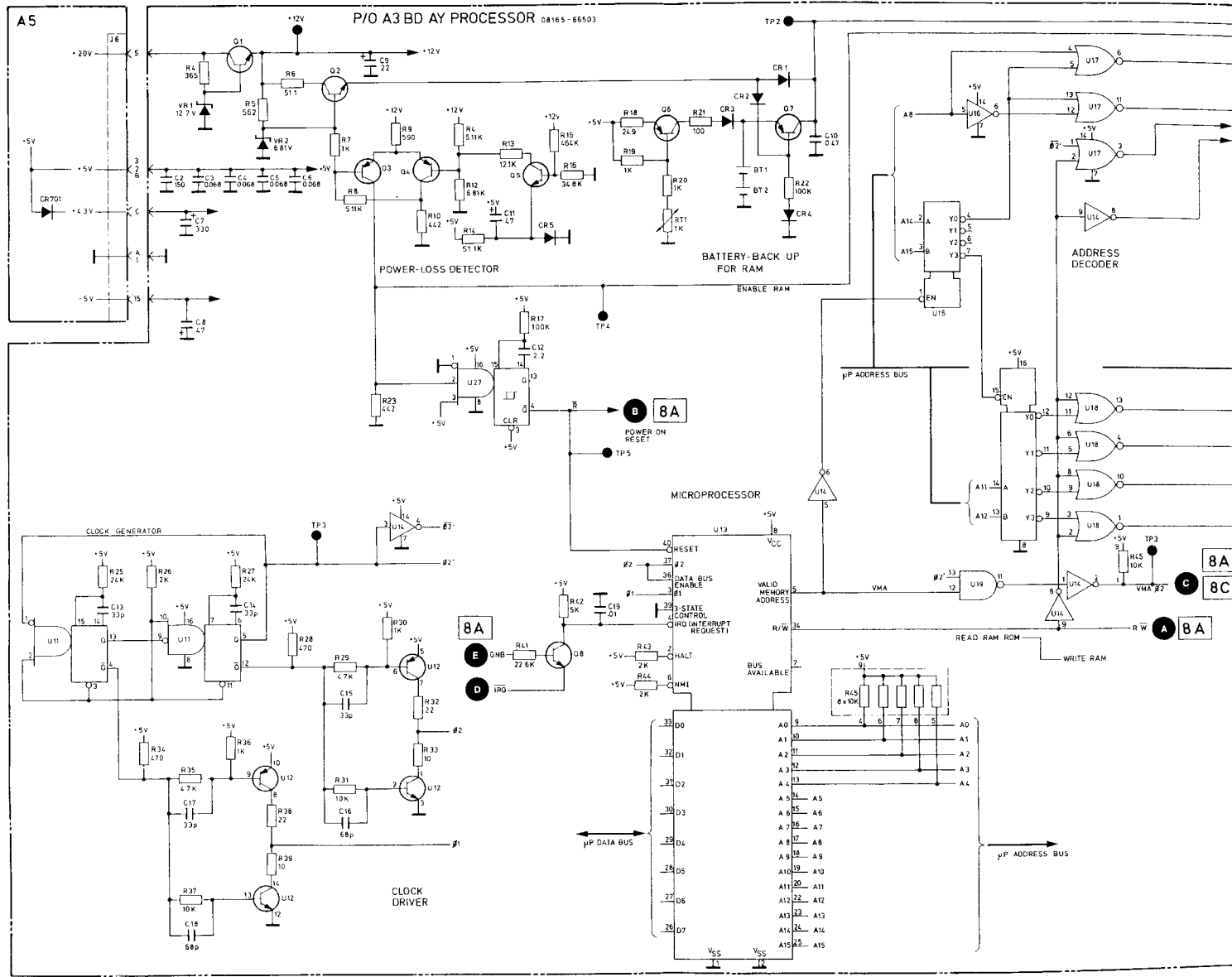

CHANGE 27 For serial numbers 2030G01600 and lower.

In Table 6-3, Replaceable Parts, make the following changes:

A3R21	0757-0401	0	RESISTOR 100 1% .125W F TC=0+/-100	24546	C4-1/8-TO-101-F
A11C407	0160-0134	1	CAPACITOR-FXD 220PF +/-5% 300VDC MICA	28480	0160-0134
A11R420	0757-0419	0	RESISTOR 681 1% .125W F TC=0+/-100	24546	C4-1/8-TO-681R-F
A11R421	0698-4479	4	RESISTOR 14K 1% .125W F TC=0+/-100	24546	C4-1/8-TO-1402-F
A11R422	0683-1055	5	RESISTOR 1M 5% .25W FC TC+/-800/+900	01121	CB1055
A11R423	2100-3109	2	RESISTOR-TRMR 2K 10% C SIDE-ADJ 17-TRN	02111	43P202
A11R424	0698-3449	6	RESISTOR 28.7K 1% .125W F TC=0+/-100	24546	C4-1/8-TO-2872-F
A11R425	0757-0419	0	RESISTOR 681 1% .125W F TC=0+/-100	24546	C4-1/8-TO-681R-F
A11R426	2100-3154	7	RESISTOR-TRMR 1K 10% C SIDE-ADJ 17-TRN	02111	43P102
A11R427	0757-0465	6	RESISTOR 100K 1% .125W F TC=0+/-100	24546	C4-1/8-TO-1003-F
A11R428	2100-3123	0	RESISTOR-TRMR 500 10% C SIDE-ADJ 17-TRN	02111	43P501
A11R429	0698-3178	8	RESISTOR 487 1% .125W F TC=0+/-100	24546	C4-1/8-TO-487R-F
A11R430	0698-4444	3	RESISTOR 4.87K 1% .125W F TC=0+/-100	24546	C4-1/8-TO-4871-F
A11R431	0698-3178	8	RESISTOR 487 1% .125W F TC=0+/-100	24546	C4-1/8-TO-487R-F
A11R432	0698-4444	3	RESISTOR 4.87K 1% .125W F TC=0+/-100	24546	C4-1/8-TO-4871-F
A11U403	1826-0432	5	IC 16-DIP-P	32293	ICL 8049 CC PE

In Table 6-3, add the following:

A11CR403	1901-0460	9	DIODE-STABISTOR 30V 150MA DO-7
A11CR404	1901-0460	9	DIODE-STABISTOR 30V 150MA DO-7

In Table 6-3 and Figure 6-1, delete MP61.
Delete A11C411, A11C412, A11Q404, A11R433 and A11U404.

CHANGE 28 For serial numbers 2030G01630 and lower.

Delete A4C514, A5L407 and A11CR405

A11C407*	0160-4298	CAPACITOR-FXD 4700PF 250V
A11C411	0160-0576	CAPACITOR-FXD 100UF 20% 50V

CHANGE 29 For serial numbers 2030G01810 and lower

In Table 6-3, Replaceable Parts List, and the relevant layouts and schematics, perform the following changes:

Delete A4C125, A11R433 and A11R434.

A11R424	0757-0466	RESISTOR-FXD 110K 1% .125W		
A11R429	0757-0438	RESISTOR-FXD 5.11K 1% .125W		
A11R430	0757-0443	RESISTOR-FXD 11K 1% .125W		
A11R432*	0757-0435	RESISTOR-FXD 3.92K 1% .125W		
A11U304	1820-1340	4 IC COMPTR CMOS MAGTD 4-BIT	04713	MC145858CP
A11U305	1820-1340	4 IC COMPTR CMOS MAGTD 4-BIT	04713	MC145858CP
A11U306	1820-1340	4 IC COMPTR CMOS MAGTD 4-BIT	04713	MC145858CP
A11U307	1820-1340	4 IC COMPTR CMOS MAGTD 4-BIT	04713	MC145858CP

Add the following:

A11R426	2100-3154	7 RESISTOR-TRMR 1K 10% C SIDE-ADJ 17-TRN	02111	43P102
---------	-----------	--	-------	--------

CHANGE 30 For serial numbers 2030G01870 and lower.

In Table 6-3, Replaceable Parts List, and the relevant layouts and schematics, perform the following changes:

A11C407*	0160-0574	CAPACITOR-FXD .022UF 100V 20%		
A11C412	0160-4617	CAPACITOR-FXD 180PF 5% 200V		

CHANGE 31 For serial numbers 2030G01900 and lower.

In Table 6-3, Replaceable Parts List, and the relevant layouts and schematics, perform the following changes:

MP16	08165-60201	9 PANEL ASSEMBLY, REAR	28480	08165-60201
------	-------------	------------------------	-------	-------------

Add the following components:

J5	1250-0118	3 CONNECTOR-RF BNC FEM SGL-HOLE-FR 50-OHM	28480	1250-0118
W4	08165-61604	CABLE ASSEMBLY, REFERENCE	28480	08165-61604
A9J1	1251-4047	7 CONNECTOR 3-PIN M POST TYPE	28480	1251-4047
A9R612	0757-0274	5 RESISTOR 1.21K 1% .125W F TC=0+-100	24546	C4-1/8-TO-1213-F

CHANGE 32 For serial numbers 2248G01930 and lower.

In Table 6-3, Replaceable Parts List, and the relevant layouts and schematics, perform the following changes:

A4C122	0160-0571	0 CAPACITOR-FXD 470PF +-20% 100VDC CER	28480	0160-0571
A4R120	0698-4425	0 RESISTOR-FXD 1.54K .125W F TC=0+-100	24546	C4-1/8-TO-1541-F
A4U102	1826-0315	3 IC OP AMP GP QUAD 14-DIP-P	27014	LM348N
A4VR103	1902-3094	3 DIODE-ZNR 5.11V 2% DO-7 PD=.4W TC=.009%	28480	1902-3094

CHANGE 33 For serial numbers 2248G01960 and lower.

In Table 6-3, Replaceable Parts List, and the relevant layouts and schematics, perform the following changes:

A13C5	0160-0174	9 CAPACITOR-FXD .47UF +80-20% 25VDC CER	28480	0160-0174
A13R2	0757-0349	5 RESISTOR 22.6K 1% .125W F TC=0+-100	24546	C4-1/8-TO-2262-F