



Advanced Test Equipment Rentals
www.atecorp.com 800-404-ATEC (2832)

ASX SERIES

AC POWER SOURCE

OPERATION
MANUAL



ASX-SERIES

OPERATION MANUAL

FOR THE
MODELS
115-ASX, 120-ASX
140-ASX, 160-ASX
315-ASX, 320-ASX
345-ASX, 360-ASX
3120-ASX

PPS PART NO. 140050

THIS MANUAL ASSIGNED TO MODEL: _____

S/N: _____

THE INFORMATION CONTAINED
IN THIS MANUAL IS PROPRIETARY TO
PACIFIC POWER SOURCE.
AND MAY NOT BE COPIED OR REPRINTED
WITHOUT ITS EXPRESSED WRITTEN CONSENT.

PACIFIC POWER SOURCE, INC.
17692 Fitch Irvine, CA 92614

FIFTH EDITION

COPYRIGHT (C) PPS MARCH, 2010

CERTIFICATION

PACIFIC POWER SOURCE CERTIFIES THAT THIS INSTRUMENT WAS THOROUGHLY TESTED AND INSPECTED AND FOUND TO MEET OR EXCEED ITS PUBLISHED SPECIFICATIONS WHEN IT WAS SHIPPED FROM THE FACTORY.

LIMITED WARRANTY

Pacific Power Source (PPS) warrants each unit to be free from defects in material and workmanship. For the period of two (2) years from the date of shipment to the purchaser, PPS will either repair or replace, at its sole discretion, any unit returned to its factory in Irvine, California. This warranty does not cover batteries. It does not cover damage arising from misuse of the unit or attempted field modifications or repairs. This warranty specifically excludes damage to other equipment connected to this unit.

Upon notice from the purchaser within (30) days of shipment of units found to be defective in material or workmanship, PPS will pay all shipping charges for the repair or replacement. If notice is received more than thirty (30) days from shipment, all shipping charges shall be paid by the purchaser. Units returned on debit memos will not be accepted and will be returned without repair.

This warranty is exclusive of all other warranties, express or implied.

TABLE OF CONTENTS

PAGE

1	GENERAL	1
1.1	USING THIS MANUAL	1
1.2	SAFETY NOTICES	2
1.3	GENERAL PRODUCT DESCRIPTION	4
2	SPECIFICATIONS	7
2.1	ELECTRICAL SPECIFICATIONS	7
2.1.1	INPUT POWER REQUIREMENTS	7
2.1.2	OUTPUT POWER	12
2.1.3	OUTPUT POWER FACTOR	22
2.1.4	OUTPUT FREQUENCY	22
2.1.5	OUTPUT DISTORTION	22
2.1.6	OUTPUT LOAD REGULATION.....	22
2.1.7	INPUT LINE REGULATION.....	22
2.1.8	OUTPUT BANDWIDTH	23
2.1.9	LOAD TRANSIENT RESPONSE.....	23
2.1.10	OUTPUT DC OFFSET	23
2.1.11	OUTPUT PROTECTION	23
2.1.12	OUTPUT CONTROL CHARACTERISTICS.....	23
2.1.13	OUTPUT ISOLATION	23
2.2	MECHANICAL SPECIFICATIONS	24
2.2.1	DIMENSIONS.....	24
2.2.2	INPUT POWER CONNECTION.....	27
2.2.3	OUTPUT POWER CONNECTION.....	33
2.2.4	CHASSIS SLIDE MOUNTS	33
2.3	ENVIRONMENTAL SPECIFICATIONS.....	33
2.3.1	TEMPERATURE RANGE	33
2.3.2	COOLING.....	33
2.3.3	THERMAL PROTECTION	33
3	INSTALLATION	34
3.1	CHASSIS PLACEMENT	34
3.2	OUTPUT VOLTAGE RANGE CONFIGURATIONS	36
3.2.1	OUTPUT VOLTAGE RANGE CONFIGURATION, MODEL 115-ASX	37
3.2.2	OUTPUT VOLTAGE RANGE, MODELS 120-ASX AND 320-ASX.....	39
3.2.3	OUTPUT VOLTAGE RANGE CONFIGURATION, MODEL 315-ASX	39
3.2.4	OUTPUT VOLTAGE RANGE CONFIGURATION, MODELS 140-ASX, 160-ASX, 345-ASX, AND 360-ASX.....	41
3.2.5	OUTPUT VOLTAGE RANGE CONFIGURATION, MODEL 3120-ASX	43
3.3	INPUT POWER CONNECTION	45
3.3.1	INPUT VOLTAGE CONFIGURATION, MODEL 115-ASX.....	45
3.3.2	INPUT VOLTAGE CONFIGURATION, MODELS 120-ASX AND 320-ASX.....	47
3.3.3	INPUT VOLTAGE CONFIGURATION, MODEL 315-ASX.....	49
3.3.5	INPUT VOLTAGE CONFIGURATION, MODEL 3120-ASX.....	53
3.3.6	INPUT POWER WIRING REQUIREMENTS.....	55
3.4	OUTPUT POWER CONNECTION	57
3.4.1	SINGLE PHASE OUTPUT	57
3.4.2	SPLIT PHASE OUTPUT	60
3.4.3	THREE PHASE OUTPUT	63
3.4.4	TRANSFORMER OUTPUTS - SPECIAL CONSIDERATIONS.....	66

TABLE OF CONTENTS

	<u>PAGE</u>
3.5 CONNECTION OF SYSTEM CONTROL UNIT (SCU).....	67
3.6 REMOTE INTERFACE	69
3.7 AUX I/O INSTALLATION.....	69
3.8 EXTERNAL SENSE CONNECTION	70
4 OPERATION.....	73
4.1 FRONT PANEL CONTROLS.....	73
4.2 INITIAL POWER-UP	75
4.3 ROUTINE POWER-UP	76
4.4 SYSTEM TURN-OFF	77
4.5 SYSTEM SHUTDOWN	77
4.5.1 SHUTDOWN CONDITIONS.....	77
4.5.2 RESETTING SHUTDOWN FAULTS.....	78
4.6 OUTPUT VOLTAGE FORMS.....	78
4.6.1 SYSTEM ARCHITECTURE	79
5 MAINTENANCE.....	81
5.1 MAINTENANCE INTERVAL	81
5.2 MAINTENANCE REQUIREMENTS	81
5.2.1 MODELS 115, 120, 315, AND 320-ASX.....	81
5.2.2 MODELS 140, 160, 345, 360, AND 3120-ASX.....	81
6 CALIBRATION.....	82
6.1 CALIBRATION INTERVAL.....	82
6.2 TEST EQUIPMENT REQUIREMENTS	82
6.3.1 CALIBRATE CONTROLLER.....	83
6.3.2 POWER SOURCE LOAD TEST	84
7 SERVICE.....	85
7.1 SERVICE PROCEDURE.....	85
7.2 ROSTER OF SYSTEM LEVEL FACTORY PART NUMBERS	85
7.3 SUB-ASSEMBLY AND CHASSIS COMPONENT PART NUMBERS	86
7.3.1 FACTORY PART NUMBERS, MODEL 115-ASX (PART NUMBER 143139)	86
7.3.2 FACTORY PART NUMBERS, MODEL 120-ASX (PART NUMBER 143148)	86
7.3.3 FACTORY PART NUMBERS, MODEL 140-ASX (PART NUMBER 143013)	87
7.3.4 FACTORY PART NUMBERS, MODEL 160-ASX (PART NUMBER 143014).....	87
7.3.5 FACTORY PART NUMBERS, MODEL 315-ASX (PART NUMBER 143145)	88
7.3.7 FACTORY PART NUMBERS, MODEL 345-ASX (PART NUMBER 143016)	89
7.3.8 FACTORY PART NUMBERS, MODEL 360-ASX (PART NUMBER 143017).....	89
7.3.9 FACTORY PART NUMBERS, MODEL 3120-ASX (PART NUMBER 143008).....	90
INDEX	91
9 MODIFICATIONS AND CHANGE NOTICES	93

LIST OF ILLUSTRATIONS

PAGE

FIGURE 1.3	ASX-SERIES POWER SOURCE - FRONT VIEW	6
FIGURE 2.1.2 (A)	MODEL 115-ASX OUTPUT DERATING CURVES	13
FIGURE 2.1.2 (B)	MODEL 120-ASX OUTPUT DERATING CURVES.....	14
FIGURE 2.1.2 (C)	MODEL 140-ASX OUTPUT DERATING CURVES	15
FIGURE 2.1.2 (D)	MODEL 160-ASX OUTPUT DERATING CURVES	16
FIGURE 2.1.2 (E)	MODEL 315-ASX OUTPUT DERATING CURVES.....	17
FIGURE 2.1.2 (F)	MODEL 320-ASX OUTPUT DERATING CURVES.....	18
FIGURE 2.1.2 (G)	MODEL 345-ASX OUTPUT DERATING CURVES	19
FIGURE 2.1.2 (H)	MODEL 360-ASX OUTPUT DERATING CURVES	20
FIGURE 2.1.2 (I)	MODEL 3120-ASX OUTPUT DERATING CURVES	21
FIGURE 2.2.1	OUTLINE DRAWING, MODELS 115, 120, 315, & 320-ASX	28
FIGURE 2.2.2	OUTLINE DRAWING, MODELS 140,160,345,360-ASX	29
FIGURE 2.2.3	OUTLINE DRAWING, MODEL 3120-ASX	30
FIGURE 2.2.4	OUTLINE DRAWING, MODELS 140,160,345 & 360-ASX MAGNETICS MODULE .	31
FIGURE 2.2.5	OUTLINE DRAWING, MODEL 3120-ASX MAGNETICS MODULE	32
FIGURE 3.2.1	MODEL 115-ASX OUTPUT VOLTAGE RANGE CONFIGURATION	38
FIGURE 3.2.2	MODEL 315-ASX OUTPUT VOLTAGE RANGE CONFIGURATION	40
FIGURE 3.2.3	MODELS 140, 160, 345, & 360-ASX OUTPUT VOLTAGE RANGE CONFIGURATION.....	42
FIGURE 3.2.4	MODEL 3120-ASX OUTPUT VOLTAGE RANGE CONFIGURATION.....	44
FIGURE 3.3.1	MODEL 115-ASX INPUT VOLTAGE CONFIGURATION.....	46
FIGURE 3.3.2	MODELS 120-ASX AND 320-ASX INPUT VOLTAGE CONFIGURATION.....	48
FIGURE 3.3.3	MODEL 315-ASX INPUT VOLTAGE CONFIGURATION	50
FIGURE 3.3.4	MODELS 140, 160, 345, AND 360-ASX INPUT VOLTAGE CONFIGURATION.....	52
FIGURE 3.3.5	MODEL 3120-ASX INPUT VOLTAGE CONFIGURATION.....	54
FIGURE 3.3.6	3120-ASX INPUT WIRING DIAGRAM.....	56
FIGURE 3.4.1.1	MODELS 115,120,140,160,315,320,345, & 360-ASX SINGLE PHASE OUTPUT CONNECTION	58
FIGURE 3.4.1.2	3120-ASX SINGLE PHASE OUTPUT CONNECTION	59
FIGURE 3.4.2.1	SPLIT PHASE OUTPUT CONNECTION.....	61
FIGURE 3.4.2.2	SPLIT PHASE OUTPUT CONNECTION.....	62
FIGURE 3.4.3.1	THREE PHASE OUTPUT CONNECTION	64
FIGURE 3.4.3.2	THREE PHASE OUTPUT CONNECTION	65
FIGURE 3.5.1	SCU CONNECTION.....	68
FIGURE 3.8.1	MODELS 115, 120, 140, 160, 315, 320, 345, & 360-ASX EXTERNAL SENSE CONNECTION.....	71
FIGURE 3.8.2	MODEL 3120-ASX EXTERNAL SENSE CONNECTION.....	72
FIGURE 4.1	FRONT PANEL CONTROLS	74
FIGURE 4.6.1	ASX-SERIES SYSTEM ARCHITECTURE	80

SECTION 1

GENERAL

1 GENERAL

This manual provides information required to use an ASX-Series AC Power Source. Operation of the ASX series models: 115-ASX, 120-ASX, 140-ASX, 160-ASX, 315-ASX, 320-ASX, 345-ASX, 360-ASX, and 3120-ASX is described in this document. This is a general Operations Manual. Installation, operation, and calibration are the subjects covered.

The ASX products are typically configured with a modular controller. This allows for the creation of systems with various control characteristics and specifications. For detailed control description and control and metering specifications, see the UPC controller manual supplied with the unit.

1.1 USING THIS MANUAL

This manual provides instructions for installation and use of the ASX-Series Power Source equipment. For this reason, it is very important that the user reads sections 1 GENERAL information, 3 INSTALLATION, and 4 OPERATION, prior to using this equipment. A thorough understanding of these sections is required to safely and properly operate this equipment.

Section 2 lists the specifications of the equipment. Knowledge of this information is required to gain maximum use of this equipment for a given application. The user is encouraged to read this section in order to gain a deeper understanding of the capabilities of the ASX-Series Power Source.

Sections 5 and 6 list MAINTENANCE and CALIBRATION requirements of this equipment. Refer to these sections when either maintenance or calibration is required.

Section 7 describes SERVICE methodology and provides system, sub-assembly, and component part numbers to aid the operator in making factory authorized field repairs.

Section 9 contains product change notices, errata, and data relative to customer specified modifications. Read Section 9 before operating the equipment. This is especially true when modifications (MODs) have been installed, since these can change system operation.

If questions arise while reading this manual, the user is encouraged to call the Pacific Power Source. Pacific maintains a toll-free number which is 1-800-854-2433 (1-800-472-8465 inside California).

1.2 SAFETY NOTICES

The ASX-Series equipment is capable of transferring very large amounts of electrical energy very quickly. This basic quality is fundamental to a high-performance power source. The warnings and cautions listed below should be observed at all times.

WARNINGS are conditions which are hazardous to user personnel. All warnings throughout this manual will be formatted as shown below. A condition which is hazardous to both personnel and equipment will be issued as a warning.

CAUTION statements indicate a dangerous situation which may damage the equipment but is not a threat to life or limb. Cautions will assume the format shown on page 3. All cautions should be rigorously observed



WARNING

THIS EQUIPMENT CONTAINS HIGH ENERGY, LOW IMPEDANCE CIRCUITS!! LETHAL POTENTIALS ARE CONTAINED WITHIN THE CABINET.

CARE MUST BE EXERCISED WHEN SERVICING THIS EQUIPMENT IN ORDER TO PREVENT SERIOUS OPERATOR INJURY OR EQUIPMENT DAMAGE.

VOLTAGE AT THE TERMINALS RESPONDS INSTANTLY WHEN THE OUTPUT IS ACTIVATED.

OBSERVE THE FOLLOWING WHEN SERVICE, MAINTENANCE, OR CALIBRATION ARE REQUIRED:

- 1) REMOVE ALL JEWELRY FROM HANDS, ARMS AND NECK WHEN SERVICING THIS EQUIPMENT. THIS PREVENTS THE POSSIBILITY OF SHORTING THROUGH THE JEWELRY AND CAUSING BURNS OR ELECTROCUTION OF THE OPERATOR.
- 2) WEAR SAFETY GLASSES WHEN SERVICING THIS EQUIPMENT TO PREVENT EYE INJURY DUE TO FLYING PARTICLES CAUSED BY ACCIDENTAL SHORT CIRCUIT CONDITIONS.
- 3) DO NOT REMOVE ANY PANEL OR COVER WITHOUT FIRST REMOVING THE INPUT SERVICE BY OPENING ALL CIRCUIT BREAKERS.
- 4) SERVICE OTHER THAN EXTERNAL CLEANING SHOULD BE REFERRED TO PERSONNEL AUTHORIZED BY THE FACTORY TO SERVICE THIS EQUIPMENT.

1.2 SAFETY NOTICES (cont.)

	WARNING
IF THIS EQUIPMENT IS NOT USED IN A MANNER SPECIFIED BY THE MANUFACTURER, THE PROTECTION PROVIDED BY THE EQUIPMENT MAY BE IMPAIRED	

	CAUTION
READ SECTIONS 1, 3, AND 4 OF THIS MANUAL BEFORE INSTALLING OR OPERATING THIS EQUIPMENT.	

1.3 GENERAL PRODUCT DESCRIPTION

The ASX-Series Power Source is high-performance AC power conversion equipment. This series of equipment features models with power ratings from 1.5 kVA to 12.0 kVA. All systems are designed to fit into a standard 19 inch instrument rack. The power sources are suitable for use as frequency converters as well as sophisticated AC test power systems.

ASX power sources are typically configured with an interchangeable controller. Controller options range from basic manual control (UPC1M and 3M) to sophisticated programmable controllers (UPC1, UPC3, UPC12 or UPC32). The manual controller allows the user to adjust voltage and frequency. The programmable controller provides all of the manual control capability, plus a wide variety of control features including program storage, waveform editing, and remote interface.

Unique to the Models 120ASX and 320ASX is the ability to operate at $150_{I-n} / 300V_{I-I}$. Unique to the model 3120ASX is the ability to provide full power in either 1, 2, or 3 phase mode of operation. The nominal (rated) output voltage range for the ASX-Series is $0-125_{I-n} / 250V_{I-I}$. Available current at specific voltages, as well as maximum output voltage varies by model. Refer to section 2.1.2 for further details

Optional output transformers are available to provide higher output voltage ranges. Standard ratios up to 2.5:1 (312/541V) as well as custom ratios are available.

The ASX-Series consists of the basic models listed below.

1. Model 115-ASX - 1.5 kVA model, capable of 1 Phase operation. Single phase output voltage range is $0-132_{I-n}$. Internal output transformer option available for higher voltages.
2. Model 120-ASX - 2.0 kVA model, capable of 1 or 2 Phase operation. Single phase output voltage range is $0-150 VAC_{I-n}$. Output voltage in 2 Phase Mode is $0-300 VAC_{L1-L2}$. Additional ranges available with custom external transformer configurations.
3. Model 140-ASX - 4.0 kVA model, capable of 1 or 2 Phase operation. Single phase output voltage range is $0-135 VAC_{I-n}$. Output voltage in 2 phase mode is $0-270VAC_{L1-L2}$. External Magnetics Module available for higher output voltage ranges.
4. Model 160-ASX -6.0 kVA model, capable of 1 or 2 Phase operation. Single phase mode provides 6kVA of power with a $0-132 VAC_{I-n}$ voltage range. 2 phase mode provides 4kVA of power with a $0-270VAC_{L1-L2}$ voltage range. External Magnetics Module available for higher output voltage ranges.
5. Model 315-ASX - 1.5 kVA model, capable of 1, 2, or 3 phase operation. Single and three phase modes provide 1.5kVA of power with a $0-132 VAC_{I-n}$ output voltage range. 2 phase mode provides 1kVA of power with a $0-264V_{I1-I2}$ voltage range. Additional ranges available with custom external transformer configurations.
6. Model 320-ASX - 2.0 kVA model, capable of 1, 2, or 3 Phase operation. Single and three phase modes provide 2.0kVA of power with a $0-150 VAC_{I-n}$ output voltage range. 2 phase mode provides 2kVA of power with a $0-300V_{I1-I2}$ voltage range. Additional ranges available with custom external transformer configurations.

1.3 GENERAL PRODUCT DESCRIPTION (cont.)

7. Model 345-ASX - 4.5 kVA model, capable of 1, 2, or 3 Phase operation. Single and three phase modes provide 4.5kVA of power with a 0-135 VAC_{1-n} output voltage range. 2 phase mode provides 3.0kVA of power with a 0-270₁₋₁₂ voltage range. External Magnetics Module available for higher output voltage ranges.
8. Model 360-ASX – 6.0 kVA model, capable of 1, 2, or 3 Phase operation. Single and three phase modes provide 6.0kVA of power with a 0-132 VAC_{1-n} output voltage range. 2 phase mode provides 4.0kVA of power with a 0-270₁₋₁₂ voltage range. External Magnetics Module available for higher output voltage ranges.
9. Model 3120-ASX - 12.0 kVA model, capable of 1, 2, or 3 Phase operation. Single, split, and three phase modes provide 12kVA of power with a 0-135 VAC_{1-n} output voltage range. 2 phase mode provides the full 12.0kVA of power with a 0-270₁₋₁₂ voltage range. External Magnetics Module available for higher output voltage ranges.
10. System Control Unit (SCU) - Self-contained chassis assembly which houses a UPC-Series controller allowing for the controller to be remotely located from the power source chassis.

External voltage sense is provided on all systems. Systems configured with the programmable controller also offer Continuous Self Calibration (CSC) output level control.

Output voltage and current metering is provided on all systems. Specifications of the metering functions vary by controller type. Refer to Section 8 of the UPC-Series Operation Manual for details relative to the metering functions.

SECTION 1 GENERAL

1.3 GENERAL PRODUCT DESCRIPTION (cont.)

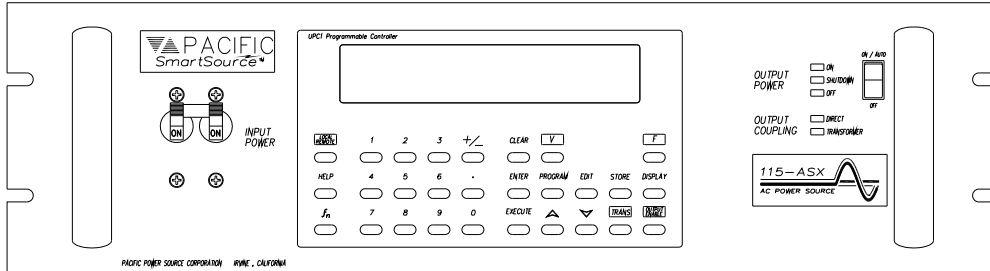

MODEL 115-ASX
W/ UPC1 CONTROLLER

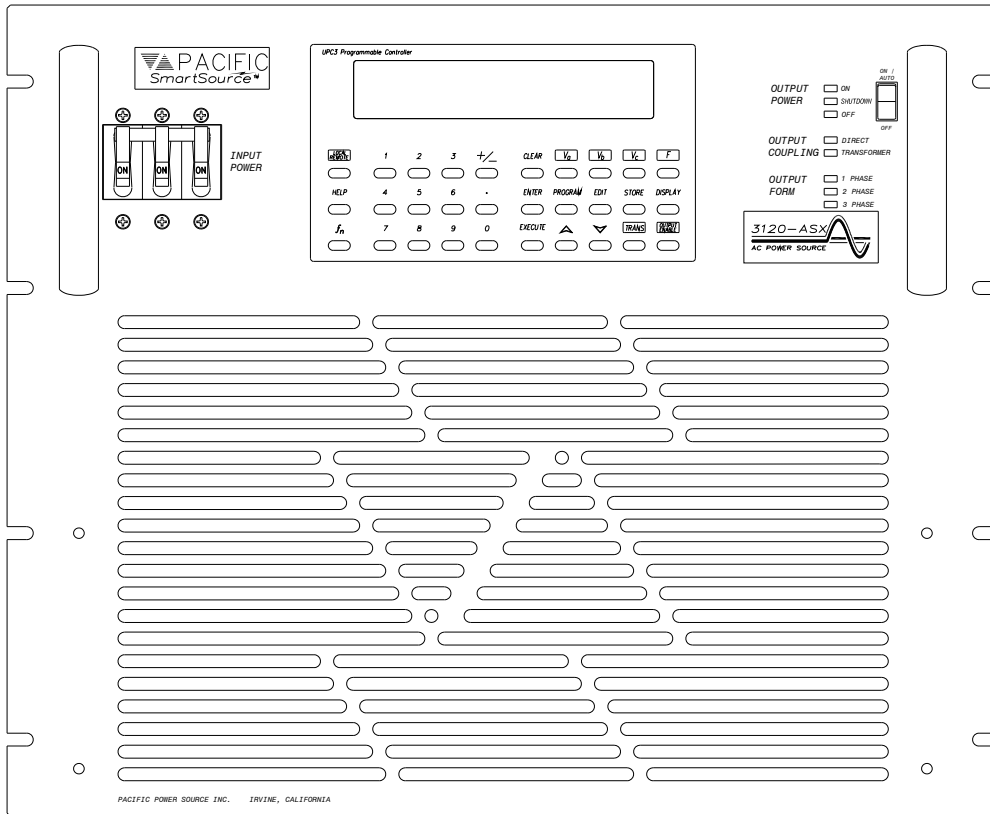

MODEL 3210-ASX
W/ UPC3 CONTROLLER

FIGURE 1.3 ASX-SERIES POWER SOURCE - FRONT VIEW

SECTION 2 SPECIFICATIONS

2 SPECIFICATIONS

This section states the electrical specifications of the ASX-Series Power Source. The specifications listed apply to all models, except as noted. Some specifications are controller dependent. These are noted as such.

2.1 ELECTRICAL SPECIFICATIONS

2.1.1 INPUT POWER REQUIREMENTS

This paragraph lists and defines the input voltage forms that are accepted by the various models within the ASX-Series line of equipment. Each model is listed separately. Refer to the appropriate model when determining proper input service requirements. The input currents listed are those for operation at full rated load. Overload conditions will result in higher input currents that still fall within the recommended input service.

The input power transformer of the ASX-Series Power Source has taps for each of the listed power forms—one of which is selected by the factory at time of order. Once selected, the unit will operate at designated voltage, $\pm 10\%$.

The standard input frequency of 50/60 Hz is offered for all models. 400 Hz (360 – 440 Hz) option is also available. Please call factory for details.

MODEL 115-ASX

INPUT VOLTAGE

The Model 115-ASX accepts one of the following single phase input voltages:

- 1) 100 VAC $\pm 10\%$, 47-63 Hz
- 2) 110 VAC $\pm 10\%$, 47-63 Hz
- 3) 120 VAC $\pm 10\%$, 47-63 Hz
- 4) 200 VAC $\pm 10\%$, 47-63 Hz
- 5) 208 VAC $\pm 10\%$, 47-63 Hz
- 6) 220 VAC $\pm 10\%$, 47-63 Hz
- 7) 230 VAC $\pm 10\%$, 47-63 Hz
- 8) 240 VAC $\pm 10\%$, 47-63 Hz

INPUT CURRENT

The input current required by the Model 115-ASX at full rated load is stated below. Recommended input service is also stated.

	V_{in}	INPUT CURRENT	SERVICE RECOMMENDED
1)	100 VAC	22 A_{rms}	25 A
2)	110 VAC	20 A_{rms}	25 A
3)	120 VAC	18 A_{rms}	25 A
4)	200 VAC	11 A_{rms}	15 A
5)	208 VAC	10 A_{rms}	15 A
6)	220 VAC	10 A_{rms}	15 A
7)	230 VAC	9 A_{rms}	15 A
8)	240 VAC	9 A_{rms}	15 A

2.1.1 INPUT POWER REQUIREMENTS (cont.)**MODEL 120-ASX****INPUT VOLTAGE**

The Model 120-ASX accepts one of the following single phase input voltages:

- 1) 100 VAC $\pm 10\%$, 47-63 Hz
- 2) 110 VAC $\pm 10\%$, 47-63 Hz
- 3) 120 VAC $\pm 10\%$, 47-63 Hz
- 4) 200 VAC $\pm 10\%$, 47-63 Hz
- 5) 208 VAC $\pm 10\%$, 47-63 Hz
- 6) 220 VAC $\pm 10\%$, 47-63 Hz
- 7) 230 VAC $\pm 10\%$, 47-63 Hz
- 8) 240 VAC $\pm 10\%$, 47-63 Hz

INPUT CURRENT

The input current required by the Model 120-ASX at full rated load is stated below. Recommended input service is also stated.

	V_{in}	INPUT CURRENT	SERVICE RECOMMENDED
1)	100 VAC	22 A_{rms}	25 A
2)	110 VAC	20 A_{rms}	25 A
3)	120 VAC	18 A_{rms}	25 A
4)	200 VAC	10 A_{rms}	15 A
5)	208 VAC	10 A_{rms}	15 A
6)	220 VAC	10 A_{rms}	15 A
7)	230 VAC	9 A_{rms}	15 A
8)	240 VAC	9 A_{rms}	15 A

MODEL 140-ASX**INPUT VOLTAGE**

The Model 140-ASX accepts one of the following three phase input voltages:

- 1) 208 VAC $\Delta \pm 10\%$, 47-63 Hz
- 2) 220 VAC $\Delta \pm 10\%$, 47-63 Hz
- 3) 240 VAC $\Delta \pm 10\%$, 47-63 Hz
- 4) 220/380 VAC $\pm 10\%$, 47-63 Hz
- 5) 230/400 VAC $\pm 10\%$, 47-63 Hz
- 6) 240/416 VAC $\pm 10\%$, 47-63 Hz
- (cost option) 7) 277/480 VAC $\pm 10\%$, 47-63 Hz

INPUT CURRENT

The input current required by the Model 140-ASX at full rated load is stated below. Recommended input service is also stated.

	V_{in}	INPUT CURRENT	SERVICE RECOMMENDED
1)	208 VAC Δ	13 A_{rms}	20 A
2)	220 VAC Δ	12 A_{rms}	20 A
3)	240 VAC Δ	11 A_{rms}	15 A
4)	220/380 VAC	7 A_{rms}	10 A
5)	230/400 VAC	7 A_{rms}	10 A
6)	240/416 VAC	6.5 A_{rms}	10 A
7)	277/480 VAC	5.5 A_{rms}	10 A

2.1.1 INPUT POWER REQUIREMENTS (cont.)**MODEL 160-ASX****INPUT VOLTAGE**

The Model 160-ASX accepts one of the following three phase input voltages:

- 1) 208 VAC Δ $\pm 10\%$, 47-63 Hz
- 2) 220 VAC Δ $\pm 10\%$, 47-63 Hz
- 3) 240 VAC Δ $\pm 10\%$, 47-63 Hz
- 4) 220/380 VAC $\pm 10\%$, 47-63 Hz
- 5) 230/400 VAC $\pm 10\%$, 47-63 Hz
- 6) 240/416 VAC $\pm 10\%$, 47-63 Hz
- (cost option) 7) 277/480 VAC $\pm 10\%$, 47-63 Hz

INPUT CURRENT

The input current required by the Model 160-ASX at full rated load is stated below. Recommended input service is also stated.

	V_{in}	INPUT CURRENT	SERVICE RECOMMENDED
1)	208 VAC Δ	20 A_{rms}	30 A
2)	220 VAC Δ	18 A_{rms}	30 A
3)	240 VAC Δ	16 A_{rms}	25 A
4)	220/380 VAC	11 A_{rms}	15 A
5)	230/400 VAC	10 A_{rms}	15 A
6)	240/416 VAC	10 A_{rms}	15 A
7)	277/480 VAC	8 A_{rms}	15 A

MODEL 315-ASX**INPUT VOLTAGE**

The Model 315-ASX accepts one of the following single phase input voltages:

- 1) 100 VAC $\pm 10\%$, 47-63 Hz
- 2) 110 VAC $\pm 10\%$, 47-63 Hz
- 3) 120 VAC $\pm 10\%$, 47-63 Hz
- 4) 200 VAC $\pm 10\%$, 47-63 Hz
- 5) 208 VAC $\pm 10\%$, 47-63 Hz
- 6) 220 VAC $\pm 10\%$, 47-63 Hz
- 7) 230 VAC $\pm 10\%$, 47-63 Hz
- 8) 240 VAC $\pm 10\%$, 47-63 Hz

INPUT CURRENT

The input current required by the Model 315-ASX at full rated load is stated below. Recommended input service is also stated.

	V_{in}	INPUT CURRENT	SERVICE RECOMMENDED
1)	100 VAC	22 A_{rms}	25 A
2)	110 VAC	20 A_{rms}	25 A
3)	120 VAC	18 A_{rms}	25 A
4)	200 VAC	11 A_{rms}	15 A
5)	208 VAC	10 A_{rms}	15 A
6)	220 VAC	10 A_{rms}	15 A
7)	230 VAC	9 A_{rms}	15 A
8)	240 VAC	9 A_{rms}	15 A

2.1.1 INPUT POWER REQUIREMENTS (cont.)**MODEL 320-ASX****INPUT VOLTAGE**

The Model 320-ASX accepts one of the following single phase input voltages:

- 1) 100 VAC $\pm 10\%$, 47-63 Hz
- 2) 110 VAC $\pm 10\%$, 47-63 Hz
- 3) 120 VAC $\pm 10\%$, 47-63 Hz
- 4) 200 VAC $\pm 10\%$, 47-63 Hz
- 5) 208 VAC $\pm 10\%$, 47-63 Hz
- 6) 220 VAC $\pm 10\%$, 47-63 Hz
- 7) 220 VAC $\pm 10\%$, 47-63 Hz
- 8) 240 VAC $\pm 10\%$, 47-63 Hz

INPUT CURRENT

The input current required by the Model 320-ASX at full rated load is stated below. Recommended input service is also stated.

	V_{in}	INPUT CURRENT	SERVICE RECOMMENDED
1)	100 VAC	22 A_{rms}	25 A
2)	110 VAC	20 A_{rms}	25 A
3)	120 VAC	18 A_{rms}	25 A
4)	200 VAC	10 A_{rms}	15 A
5)	208 VAC	10 A_{rms}	15 A
6)	220 VAC	10 A_{rms}	15 A
7)	230 VAC	9 A_{rms}	15 A
8)	240 VAC	9 A_{rms}	15 A

MODEL 345-ASX**INPUT VOLTAGE**

The Model 345-ASX accepts one of the following three phase input voltages:

- 1) 208 VAC $\Delta \pm 10\%$, 47-63 Hz
- 2) 220 VAC $\Delta \pm 10\%$, 47-63 Hz
- 3) 240 VAC $\Delta \pm 10\%$, 47-63 Hz
- 4) 220/380 VAC $\pm 10\%$, 47-63 Hz
- 5) 230/400 VAC $\pm 10\%$, 47-63 Hz
- 6) 240/416 VAC $\pm 10\%$, 47-63 Hz
- (cost option) 7) 277/480 VAC $\pm 10\%$, 47-63 Hz

INPUT CURRENT

The input current required by the Model 345-ASX at full rated load is stated below. Recommended input service is also stated.

	V_{in}	INPUT CURRENT	Service Recommended
1)	208 VAC Δ	15 A_{rms}	25 A
2)	220 VAC Δ	14 A_{rms}	25 A
3)	240 VAC Δ	12 A_{rms}	20 A
4)	220/380 VAC	8 A_{rms}	15 A
5)	230/400 VAC	8 A_{rms}	15 A
6)	240/416 VAC	7.5 A_{rms}	15 A
7)	277/480 VAC	6 A_{rms}	10 A

2.1.1 INPUT POWER REQUIREMENTS (cont.)**MODEL 360-ASX****INPUT VOLTAGE**

The Model 360-ASX accepts one of the following three phase input voltages:

- | | | | |
|---------------|----|-----------------------------|----------|
| | 1) | 208 VAC $\Delta \pm 10\%$, | 47-63 Hz |
| | 2) | 220 VAC $\Delta \pm 10\%$, | 47-63 Hz |
| | 3) | 240 VAC $\Delta \pm 10\%$, | 47-63 Hz |
| | 4) | 220/380 VAC $\pm 10\%$, | 47-63 Hz |
| | 5) | 230/400 VAC $\pm 10\%$, | 47-63 Hz |
| | 6) | 240/416 VAC $\pm 10\%$, | 47-63 Hz |
| (cost option) | 7) | 277/480 VAC $\pm 10\%$, | 47-63 Hz |

INPUT CURRENT

The input current required by the Model 360-ASX at full rated load is stated below. Recommended input service is also stated.

	V_{in}	INPUT CURRENT	Service Recommended
1)	208 VAC Δ	20 A _{rms}	30 A
2)	220 VAC Δ	18 A _{rms}	30 A
3)	240 VAC Δ	16 A _{rms}	25 A
4)	220/380 VAC	11 A _{rms}	15 A
5)	230/400 VAC	11 A _{rms}	15 A
6)	240/416 VAC	10 A _{rms}	15 A
7)	277/480 VAC	8 A _{rms}	15 A

MODEL 3120-ASX**INPUT VOLTAGE**

The Model 3120-ASX accepts one of the following three phase input voltages:

- | | |
|----|--------------------------------------|
| 1) | 208 VAC $\Delta \pm 10\%$, 47-63 Hz |
| 2) | 220 VAC $\Delta \pm 10\%$, 47-63 Hz |
| 3) | 230 VAC $\Delta \pm 10\%$, 47-63 Hz |
| 4) | 240 VAC $\Delta \pm 10\%$, 47-63 Hz |
| 5) | 220/380 VAC $\pm 10\%$, 47-63 Hz |
| 6) | 230/400 VAC $\pm 10\%$, 47-63 Hz |
| 7) | 240/416 VAC $\pm 10\%$, 47-63 Hz |
| 8) | 277/480 VAC $\pm 10\%$, 47-63 Hz |

INPUT CURRENT

The input current required by the Model 3120-ASX at full rated load is stated below. Recommended input service is also stated.

	V_{in}	INPUT CURRENT	SERVICE RECOMMENDED
1)	208 VAC Δ	40 A _{rms}	60 A
2)	220 VAC Δ	36 A _{rms}	50 A
3)	230 VAC Δ	36 A _{rms}	50 A
4)	240 VAC Δ	32 A _{rms}	50 A
5)	220/380 VAC	22 A _{rms}	30 A
6)	230/400 VAC	21 A _{rms}	30 A
7)	240/416 VAC	20 A _{rms}	30 A
8)	277/480 VAC	16 A _{rms}	20 A

SECTION 2 SPECIFICATIONS

2.1.2 OUTPUT POWER

OUTPUT VOLTAGE RANGE

DIRECT-COUPLED

The standard output voltage ranges of the ASX-Series are: 0-132 VAC_{i-n} for the Models 115-ASX, 160-ASX, 315-ASX, and 360-ASX; 0-135 VAC_{i-n} for the Models 140-ASX, 345-ASX, and 3120-ASX; and 0-150 VAC_{i-n} for the Models 120-ASX and 320-ASX, when operated in the direct-coupled mode. These voltages are stated for nominal input voltage applied.

TRANSFORMER-COUPLED

The output voltage range of the ASX-Series Power Source varies when operated in the transformer-coupled mode. Maximum output voltage is determined by the transformer turns ratio. See list below for maximum output voltage vs. turns ratio.

<u>URNS RATIO</u>	<u>MAXIMUM OUTPUT VOLTAGE (No Load)</u>
1.5:1	198 VAC _{i-n} Models 115-ASX, 160-ASX, 315-ASX, and 360-ASX 203 VAC _{i-n} Models 140-ASX, 345-ASX, and 3120-ASX
2.0:1	264 VAC _{i-n} Models 115-ASX, 160-ASX, 315-ASX, and 360-ASX 270 VAC _{i-n} Models 140-ASX, 345-ASX, and 3120-ASX
2.5:1	330 VAC _{i-n} Models 115-ASX, 160-ASX, 315-ASX, and 360-ASX 338 VAC _{i-n} Models 140-ASX, 345-ASX, and 3120-ASX

OUTPUT CURRENT

FULL-RATED CURRENT

The full-rated output current the ASX-Series Power Source is listed below by model number. Refer to the derating charts of Figures 2.1.2(A-H) for maximum output current at a specific output form, voltage, or power factor. Output current ratings are scaled appropriately when using transformer-coupled outputs. Note that the 315-ASX has reduced ratings when the output magnetics option is installed (the "T" added to the model number designates the output magnetics option). All other models retain their full-rated output current with the output magnetics option installed.

<u>MODEL</u>	<u>1φ</u>		<u>2φ</u>		<u>3φ</u>	
	<i>I</i> _{out, rms}	<i>I</i> _{out, pk}	<i>I</i> _{out, rms}	<i>I</i> _{out, pk}	<i>I</i> _{out, rms}	<i>I</i> _{out, pk}
115-ASX	16 A	35 A	N/A	N/A	N/A	N/A
120-ASX	20 A	90 A	14 A	45 A	N/A	N/A
140-ASX	32 A	90 A	16 A	45 A	N/A	N/A
160-ASX	48 A	120 A	16 A	45 A	N/A	N/A
315-ASX	12 A	69 A	6 A	23 A	4 A	23 A
315-ASXT	9 A	69 A	6 A	23 A	3 A	23 A
	(with output magnetics option)					
320-ASX	20 A	69 A	12 A	23 A	7 A	23 A
345-ASX	36 A	100 A	12 A	40 A	16 A	40 A
360-ASX	48 A	120 A	16 A	45 A	16 A	45 A
3120-ASX	96 A	300 A	48 A	150 A	32 A	100 A

OVERLOAD OPERATION

The ASX-Series Power Source will deliver up to 125% of rated RMS output current at 25°C ambient room temperature, nominal through 10% high input line voltage, and at a power factor of 0.8. Elevated ambient temperatures, low input line voltage, or power factors between 0.8 and 1.0 will increase the internal dissipation of the power source and can cause overload shutdown due to over-temperature conditions. Length of time to reach over-temperature varies with the models and the above parameters.

2.1.2 OUTPUT POWER (cont.)

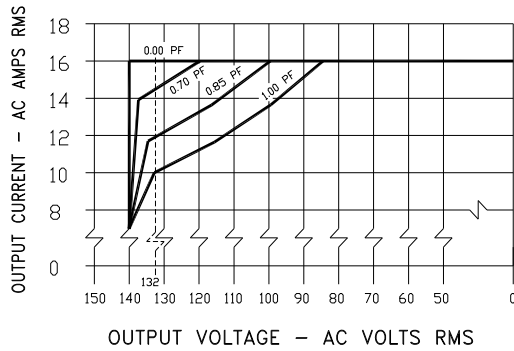

RATING CURVE

Rated continuous load current as a function of power factor and output voltage—Nominal input line.
 Short term overloads to 20 Amps are permitted. Operating time before thermal shutdown or circuit breaker trip varies from seconds to several minutes depending on line and temperature conditions.

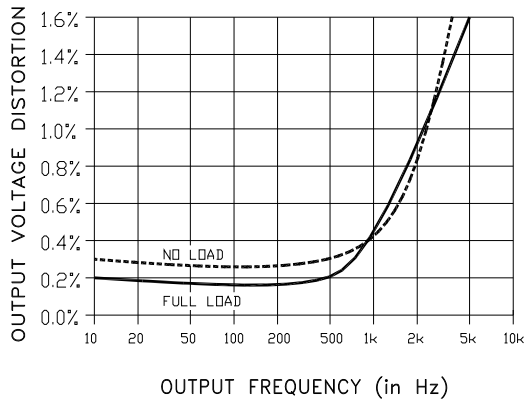

TYPICAL OUTPUT DISTORTION

Output Voltage THD vs. Frequency

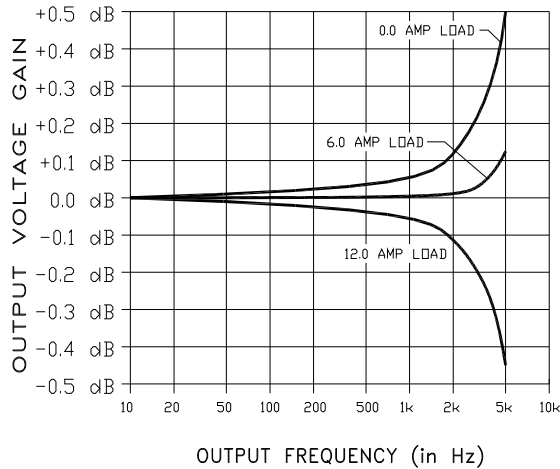

FREQUENCY RESPONSE

Output Voltage Gain vs. Frequency
 Measured at 120 Vac, with resistive load

FIGURE 2.1.2 (A) MODEL 115-ASX OUTPUT DERATING CURVES

SECTION 2 SPECIFICATIONS

2.1.2 OUTPUT POWER (cont.)

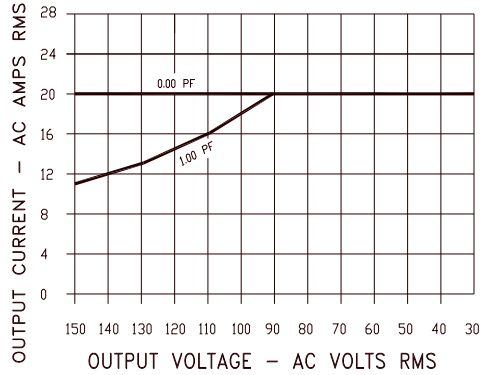

RATING CURVE
1 PHASE MODE

Rated continuous load current as a function of Power Factor and Output Voltage - Nominal Input Line.

Short term overloads to 30 Amps are permitted. Operating time before thermal shutdown or circuit breaker trip varies from seconds to several minutes depending upon line and temperature conditions.

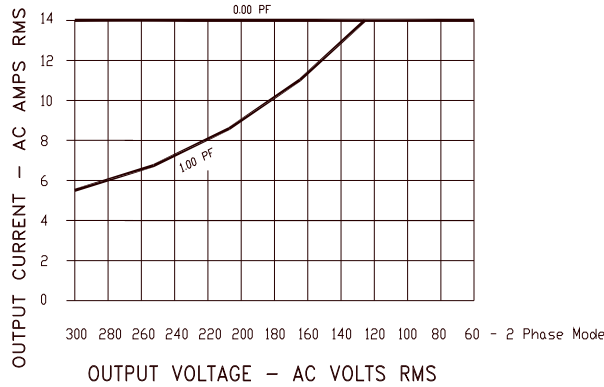

RATING CURVE
2 PHASE MODE

Rated continuous load current as a function of Power Factor and Output Voltage - Nominal Input Line.

Short term overloads to 15 Amps are permitted. Operating time before thermal shutdown or circuit breaker trip varies from seconds to several minutes depending upon line and temperature conditions.

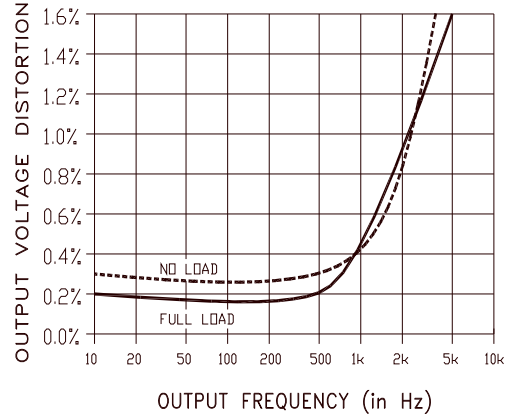

TYPICAL OUTPUT DISTORTION
Output Voltage THD vs. Frequency

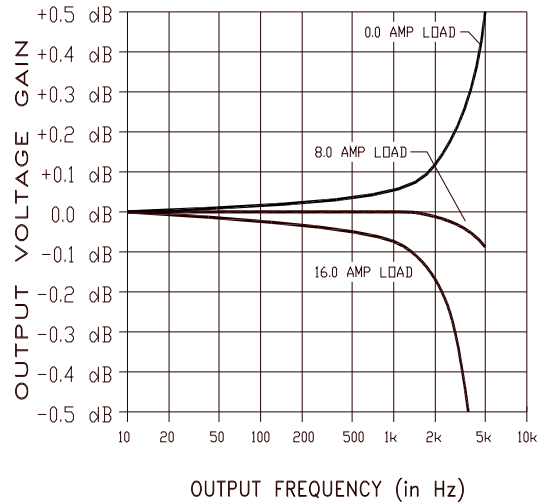

FREQUENCY RESPONSE
Output Voltage Gain vs. Frequency
Measured at 120 VAC, with resistive load

FIGURE 2.1.2 (B) MODEL 120-ASX OUTPUT DERATING CURVES

2.1.2 OUTPUT POWER (cont.)

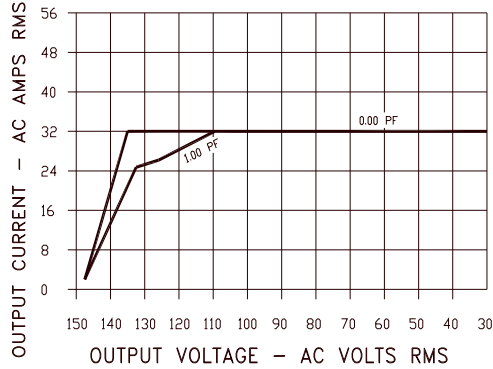

RATING CURVE
1 PHASE MODE

Rated continuous load current as a function of Power Factor and Output Voltage - Nominal Input Line.

Short term overloads to 40 Amps are permitted. Operating time before thermal shutdown or circuit breaker trip varies from seconds to several minutes depending upon line and temperature conditions.

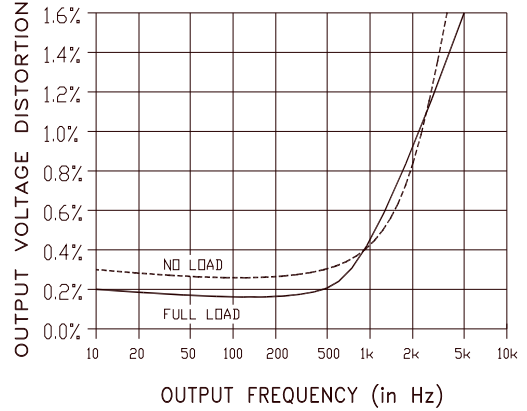

TYPICAL OUTPUT DISTORTION
Output Voltage THD vs. Frequency

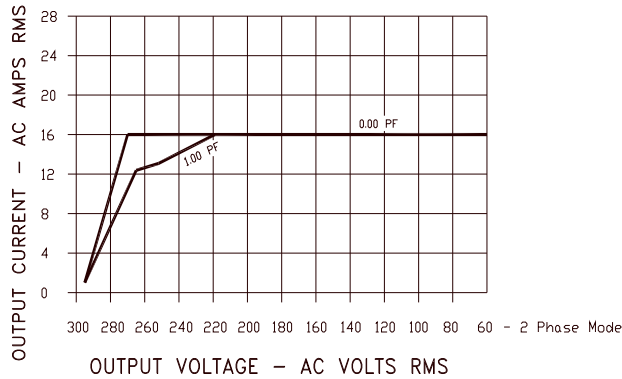

RATING CURVE
2 PHASE MODE

Rated continuous load current as a function of Power Factor and Output Voltage - Nominal Input Line.

Short term overloads to 20 Amps are permitted. Operating time before thermal shutdown or circuit breaker trip varies from seconds to several minutes depending upon line and temperature conditions.

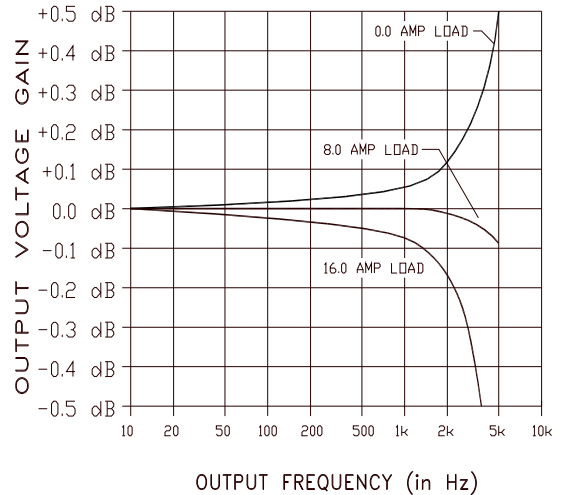

FREQUENCY RESPONSE
Output Voltage Gain vs. Frequency
Measured at 120 VAC, with resistive load

FIGURE 2.1.2 (C) MODEL 140-ASX OUTPUT DERATING CURVES

SECTION 2 SPECIFICATIONS

2.1.2 OUTPUT POWER (cont.)

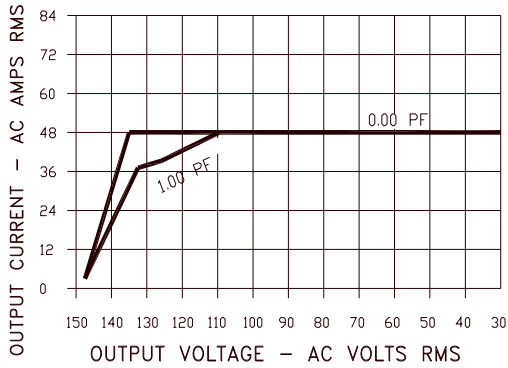

RATING CURVE
1 PHASE MODE

Rated continuous load current as a function of Power Factor and Output Voltage - Nominal Input Line.

Short term overloads to 60 Amps are permitted. Operating time before thermal shutdown or circuit breaker trip varies from seconds to several minutes depending upon line and temperature conditions.

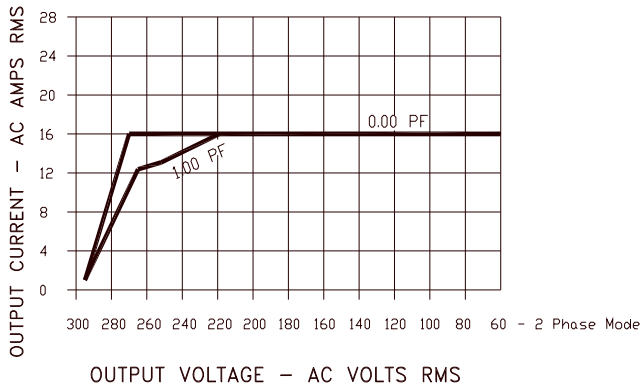

RATING CURVE
2 PHASE MODES

Rated continuous load current as a function of Power Factor and Output Voltage - Nominal Input Line.

Short term overloads to 20 Amps are permitted. Operating time before thermal shutdown or circuit breaker trip varies from seconds to several minutes depending upon line and temperature conditions.

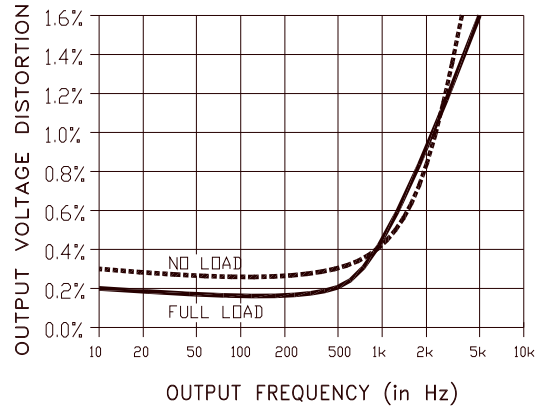

TYPICAL OUTPUT DISTORTION
Output Voltage THD vs. Frequency

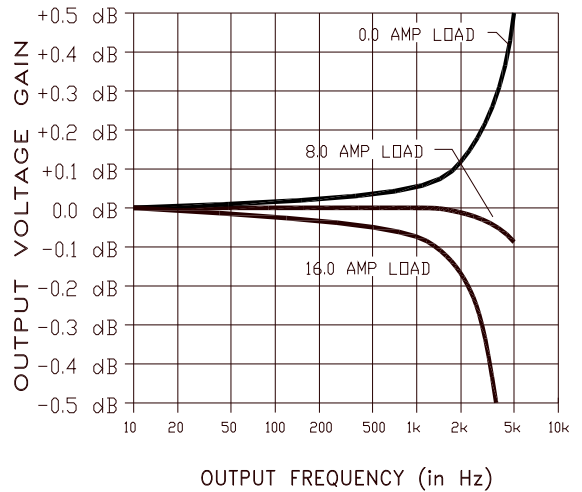

FREQUENCY RESPONSE
Output Voltage Gain vs. Frequency
Measured at 120 VAC, with resistive load

FIGURE 2.1.2 (D) MODEL 160-ASX OUTPUT DERATING CURVES

2.1.2 OUTPUT POWER (cont.)

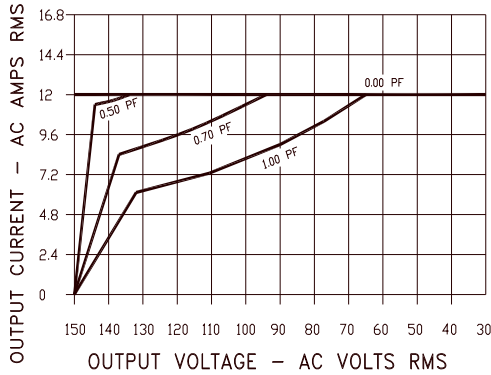

RATING CURVE
1 PHASE MODE

Rated continuous load current as a function of Power Factor and Output Voltage - Nominal Input Line.

Short term overloads to 20 Amps are permitted. Operating time before thermal shutdown or circuit breaker trip varies from seconds to several minutes depending upon line and temperature conditions.

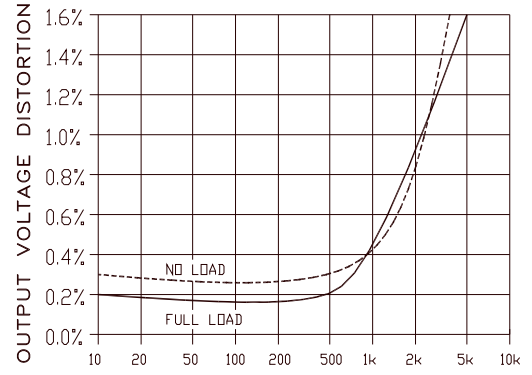

TYPICAL OUTPUT DISTORTION
Output Voltage THD vs. Frequency

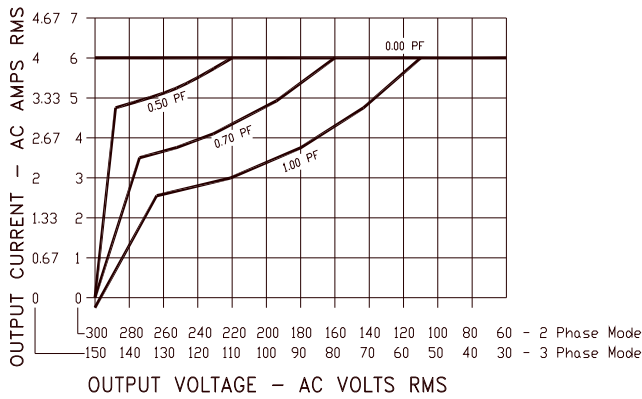

RATING CURVE
2 & 3 PHASE MODES

Rated continuous load current as a function of Power Factor and Output Voltage - Nominal Input Line.

Short term overloads to 12 Amps are permitted. Operating time before thermal shutdown or circuit breaker trip varies from seconds to several minutes depending upon line and temperature conditions.

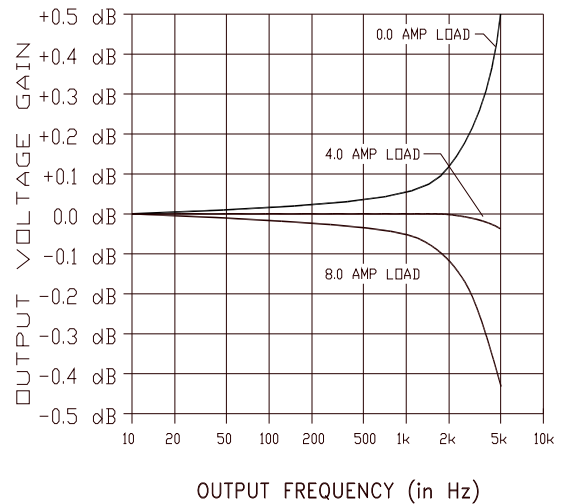

FREQUENCY RESPONSE
Output Voltage Gain vs. Frequency
Measured at 120 VAC, with resistive load

FIGURE 2.1.2 (E) MODEL 315-ASX OUTPUT DERATING CURVES

SECTION 2 SPECIFICATIONS

2.1.2 OUTPUT POWER (cont.)

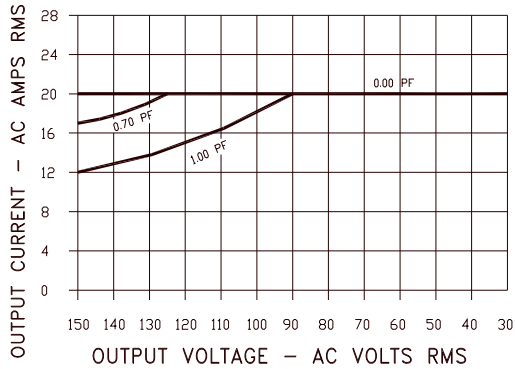

RATING CURVE
1 PHASE MODE

Rated continuous load current as a function of Power Factor and Output Voltage - Nominal Input Line.

Short term overloads to 30 Amps are permitted. Operating time before thermal shutdown or circuit breaker trip varies from seconds to several minutes depending upon line and temperature conditions.

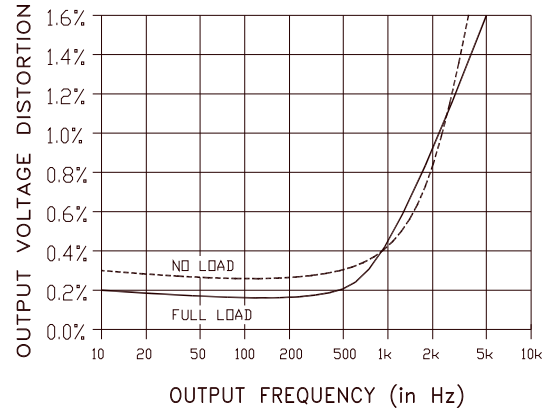

TYPICAL OUTPUT DISTORTION
Output Voltage THD vs. Frequency

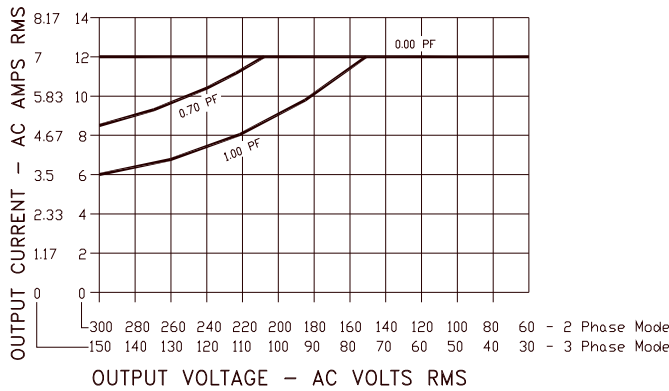

RATING CURVE
2 & 3 PHASE MODES

Rated continuous load current as a function of Power Factor and Output Voltage - Nominal Input Line.

Short term overloads to 15 Amps are permitted. Operating time before thermal shutdown or circuit breaker trip varies from seconds to several minutes depending upon line and temperature conditions.

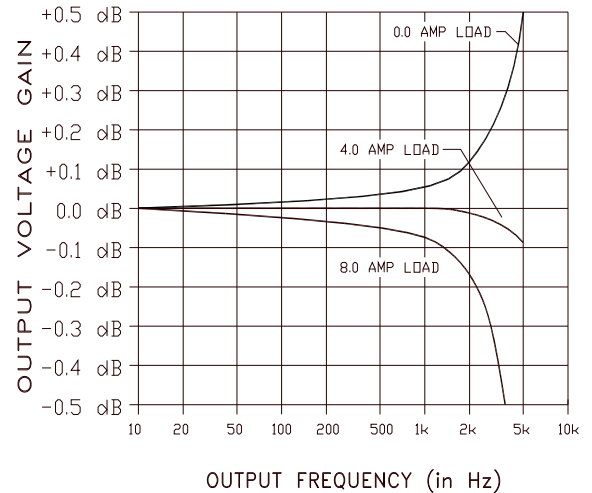

FREQUENCY RESPONSE
Output Voltage Gain vs. Frequency
Measured at 120 VAC, with resistive load

FIGURE 2.1.2 (F) MODEL 320-ASX OUTPUT DERATING CURVES

2.1.2 OUTPUT POWER (cont.)

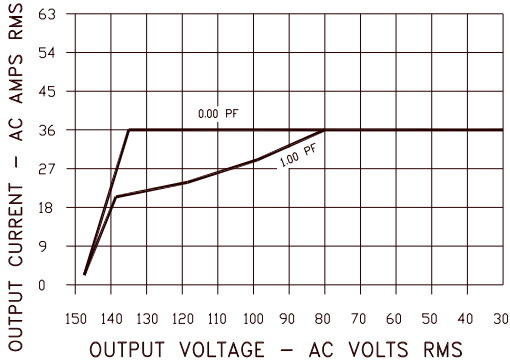

RATING CURVE
1 PHASE MODE

Rated continuous load current as a function of Power Factor and Output Voltage - Nominal Input Line.

Short term overloads to 60 Amps are permitted. Operating time before thermal shutdown or circuit breaker trip varies from seconds to several minutes depending upon line and temperature conditions.

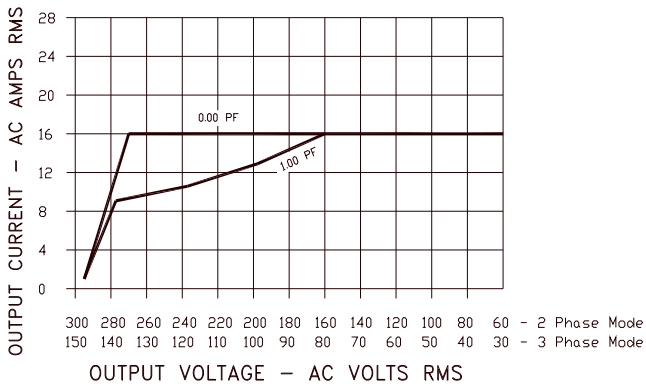

RATING CURVE
2 & 3 PHASE MODES

Rated continuous load current as a function of Power Factor and Output Voltage - Nominal Input Line.

Short term overloads to 20 Amps are permitted. Operating time before thermal shutdown or circuit breaker trip varies from seconds to several minutes depending upon line and temperature conditions.

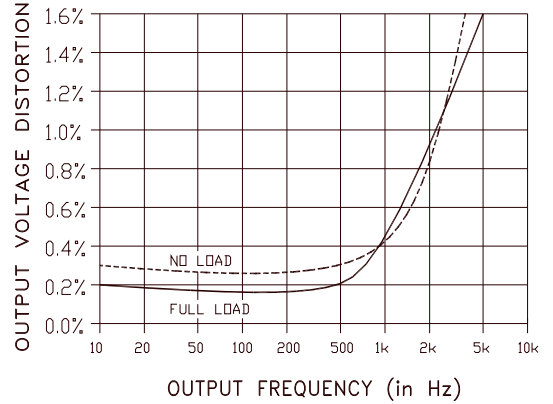

TYPICAL OUTPUT DISTORTION
Output Voltage THD vs. Frequency

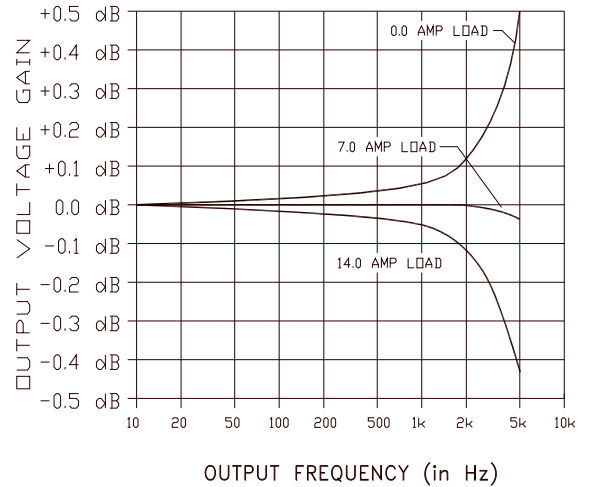

FREQUENCY RESPONSE
Output Voltage Gain vs. Frequency
Measured at 120 VAC, with resistive load

FIGURE 2.1.2 (G) MODEL 345-ASX OUTPUT DERATING CURVES

SECTION 2 SPECIFICATIONS

2.1.2 OUTPUT POWER (cont.)

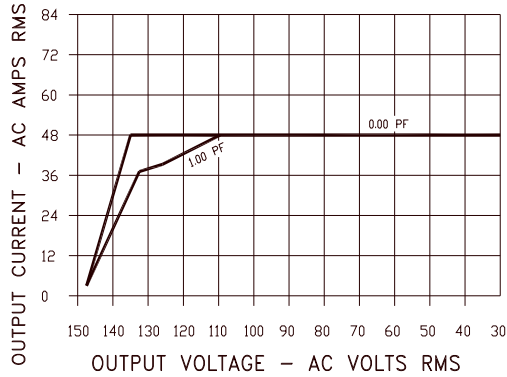

RATING CURVE
1 PHASE MODE

Rated continuous load current as a function of Power Factor and Output Voltage - Nominal Input Line.

Short term overloads to 60 Amps are permitted. Operating time before thermal shutdown or circuit breaker trip varies from seconds to several minutes depending upon line and temperature conditions.

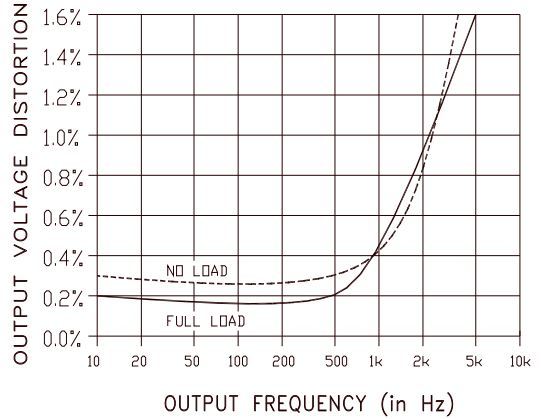

TYPICAL OUTPUT DISTORTION
Output Voltage THD vs. Frequency

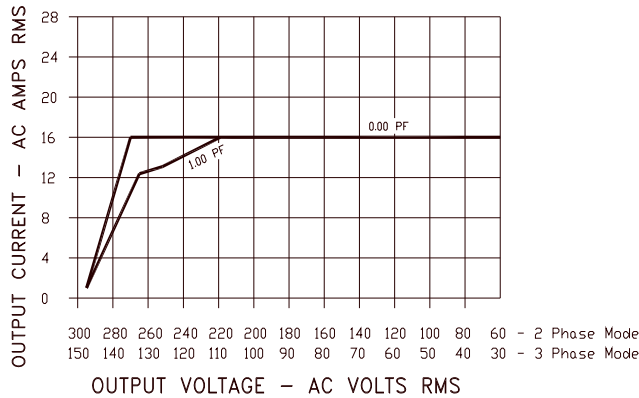

RATING CURVE
2 & 3 PHASE MODES

Rated continuous load current as a function of Power Factor and Output Voltage - Nominal Input Line.

Short term overloads to 20 Amps are permitted. Operating time before thermal shutdown or circuit breaker trip varies from seconds to several minutes depending upon line and temperature conditions.

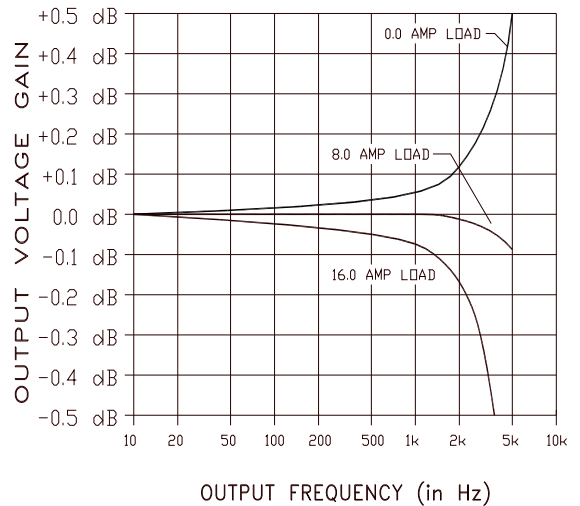

FREQUENCY RESPONSE
Output Voltage Gain vs. Frequency
Measured at 120 VAC, with resistive load

FIGURE 2.1.2 (H) MODEL 360-ASX OUTPUT DERATING CURVES

2.1.2 OUTPUT POWER (cont.)

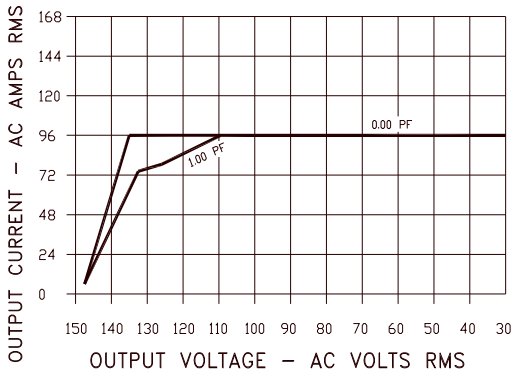

RATING CURVE
1 PHASE MODE

Rated continuous load current as a function of Power Factor and Output Voltage - Nominal Input Line.

Short term overloads to 120 Amps are permitted. Operating time before thermal shutdown or circuit breaker trip varies from seconds to several minutes depending upon line and temperature conditions.

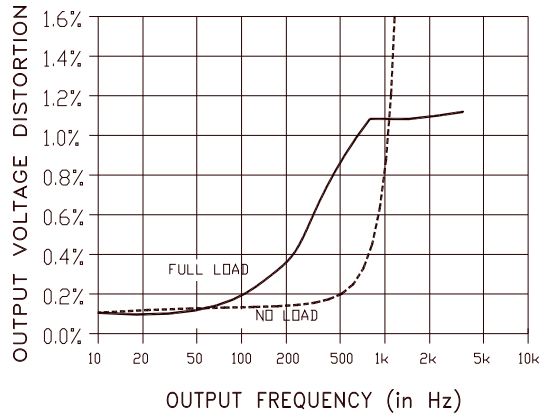

TYPICAL OUTPUT DISTORTION
Output Voltage THD vs. Frequency

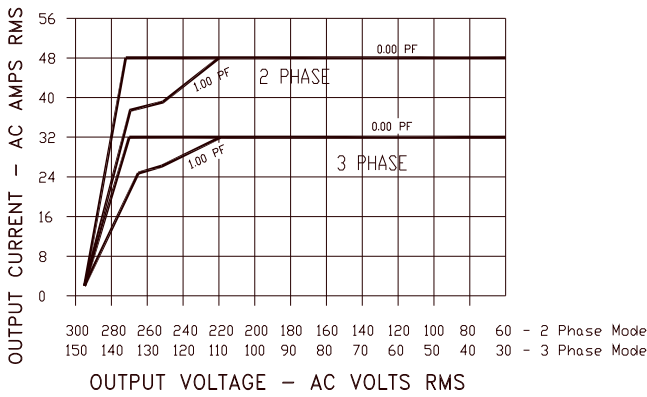

RATING CURVE
2 & 3 PHASE MODES

Rated continuous load current as a function of Power Factor and Output Voltage - Nominal Input Line.

Short term overloads to 40 Amps are permitted. Operating time before thermal shutdown or circuit breaker trip varies from seconds to several minutes depending upon line and temperature conditions.

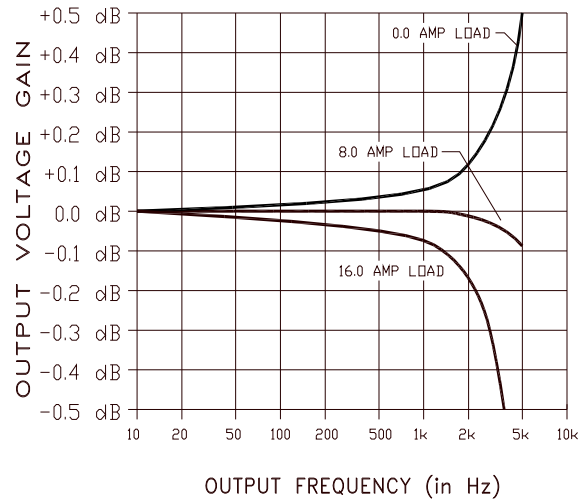

FREQUENCY RESPONSE
Output Voltage Gain vs. Frequency
Measured at 120 VAC, with resistive load

FIGURE 2.1.2 (I) MODEL 3120-ASX OUTPUT DERATING CURVES

2.1.3 OUTPUT POWER FACTOR

The ASX-Series Power Source is designed to operate into any load power factor. However, the derating charts of Figures 2.1.2(A-H) should be consulted for system capabilities at specific output power factors.

2.1.4 OUTPUT FREQUENCY

The output frequency range of the ASX-Series Power Source is determined by the controller which is installed in the system. Refer to the appropriate controller manual for output frequency specifications.

2.1.5 OUTPUT DISTORTION

The output distortion of the ASX-Series Power Source is typically less than 0.25% THD for output frequencies in the range of 15 to 200 Hz. Output Distortion of each model for frequencies in the range of 200 to 1,200 Hz is indicated in FIGURE 2.1.2(A) through FIGURE 2.1.2(I) on PAGE 13 to PAGE 21.

2.1.6 OUTPUT LOAD REGULATION

DIRECT-COUPLED

Load regulation of the ASX-Series Power Source is typically less than 0.25% for output frequencies in the range of 15 to 400 Hz. Load Regulation is less than 1.50% for frequencies in the range of 400 to 1,200 Hz.

TRANSFORMER-COUPLED

Load regulation of the ASX-Series Power Source varies with Turns Ratio when the system is operated in the transformer-coupled mode. Use of Continuous-Self-Calibration (CSC) improves load regulation to less than 0.10%. Uncompensated load regulation is listed below.

TURNS RATIO	LOAD REGULATION (Uncompensated)
1.5:1	2%
2.0:1	4%
2.5:1	5%

2.1.7 INPUT LINE REGULATION

Input line regulation of the ASX-Series Power Source is less than 0.1% for a 10% change in line voltage (provided, input line voltage remains within the specified range of $\pm 10\%$ of nominal rating).

2.1.8 OUTPUT BANDWIDTH

The output bandwidth of the ASX-Series Power Source is listed below.

Full Power:	15	to	400 Hz (± 0.10 db [$\pm 1\%$])
	400	to	1,200 Hz (± 0.25 db [$\pm 3\%$])
Small Signal:	5	to	2,500 Hz (± 0.5 db [$\pm 6\%$])
	(rated at 10% of full-scale output voltage)		

2.1.9 LOAD TRANSIENT RESPONSE

Output load transient response for a 10-90% load induced step transient is approximately 60 μ sec.

2.1.10 OUTPUT DC OFFSET

The DC offset present on the output of the ASX-Series Power Source is less than 5 mVDC.

2.1.11 OUTPUT PROTECTION

The output of the ASX-Series Power Source is protected through the use of electronic current limiting. The output will automatically recover when the output fault is removed. Thermal overload protection is also provided. Refer to paragraph 2.3.3 for details.

Note:

The programmable controller also provides programmable current limit. Refer to the UPC-Series Operation Manual for details.

2.1.12 OUTPUT CONTROL CHARACTERISTICS

Output control characteristics, sync I/O signals, and metering capabilities are determined by the controller which is installed. Refer to the controller manual for details.

2.1.13 OUTPUT ISOLATION

The output of the ASX-Series is galvanically isolated from the chassis and input power. Output Neutral to Chassis voltage is allowed to be 150 VAC, maximum. (Refer to Paragraph 3.4.4 for special considerations when using transformer-coupled outputs.)

SECTION 2 SPECIFICATIONS

2.2 MECHANICAL SPECIFICATIONS

This paragraph describes the mechanical characteristics of the ASX-Series Power Sources.

2.2.1 DIMENSIONS

Dimensions of the ASX-Series Power Sources are listed below.

MODEL 115-ASX

Height: 5.25" [134 mm]; 3 rack unit
Width: 19.00" [483 mm] (front panel); 16.75" [426 mm] (chassis)
Depth: 23.00" [584 mm] (measured from back side of front panel, excludes terminal blocks)
Weight: 70 lbs. [32 kg] (w/o output transformers);
95 lbs. [43 kg] (with output transformers)

Refer to Figure 2.2.1 for the outline drawing of the Model 115-ASX.

MODEL 120-ASX

Height: 5.25" [134 mm]; 3 rack unit
Width: 19.00" [483 mm] (front panel); 16.75" [426 mm] (chassis)
Depth: 23.00" [584 mm] (measured from back side of front panel, excludes terminal blocks)
Weight: 80 lbs. [36 kg]

Refer to Figure 2.2.1 for the outline drawing of the Model 120-ASX.

MODEL 140-ASX

Power Source:

Height: 8.75" [222 mm]; 5 rack unit
Width: 19.00" [483 mm] (front panel); 16.75" [426 mm] (chassis)
Depth: 23.12" [587 mm] (measured from back side of front panel, excludes terminal blocks)
Weight: 120 lbs. [55 kg]

Refer to Figure 2.2.2 for the outline drawing of the Model 140-ASX.

Magnetics Module: (Houses Output Transformers used with the 140, 345, & 360-ASX power sources.)

Height: 5.25" [134 mm]; 3 rack unit
Width: 19.00" [483 mm] (front panel); 16.75" [426 mm] (chassis)
Depth: 23.50" [597 mm]
Weight: 120 lbs. [55 kg]

Refer to Figure 2.2.4 for the outline drawing of the Magnetics Module.

2.2.1 DIMENSIONS (cont.)**MODEL 160-ASX**

Power Source:

Height: 8.75" [222 mm]; 5 rack unit
 Width: 19.00" [483 mm] (front panel); 16.75" [426 mm] (chassis)
 Depth: 23.12" [587 mm] (measured from back side of front panel, excludes terminal blocks)
 Weight: 120 lbs. [55 kg]

Refer to Figure 2.2.2 for the outline drawing of the Model 160-ASX.

Magnetics Module:

(Houses Output Transformers used with the 140, 160, 345, & 360-ASX power sources.)

Height: 5.25" [134 mm]; 3 rack unit
 Width: 19.00" [483 mm] (front panel); 16.75" [426 mm] (chassis)
 Depth: 23.50" [597 mm]
 Weight: 120 lbs. [55 kg]

Refer to Figure 2.2.4 for the outline drawing of the Magnetics Module.

MODEL 315-ASX

Height: 5.25" [134 mm]; 3 rack unit
 Width: 19.00" [483 mm] (front panel); 16.75" [426 mm] (chassis)
 Depth: 23.00" [584 mm] (measured from back side of front panel, excludes terminal blocks)
 Weight: 75 lbs. [34 kg] (w/o output transformers);

Refer to Figure 2.2.1 for the outline drawing of the Model 315-ASX.

MODEL 320-ASX

Height: 5.25" [134 mm]; 3 rack unit
 Width: 19.00" [483 mm] (front panel); 16.75" [426 mm] (chassis)
 Depth: 23.00" [584 mm] (measured from back side of front panel, excludes terminal blocks)
 Weight: 85 lbs. [39 kg]

Refer to Figure 2.2.1 for the outline drawing of the Model 320-ASX.

SECTION 2 SPECIFICATIONS

2.2.1 DIMENSIONS (cont.)

MODEL 345-ASX

Power Source:

Height: 8.75" [222 mm]; 5 rack unit
Width: 19.00" [483 mm] (front panel); 16.75" [426 mm] (chassis)
Depth: 23.12" [587 mm] (measured from back side of front panel, excludes terminal blocks)
Weight: 125 lbs. [57 kg]

Refer to Figure 2.2.2 for the outline drawing of the Model 345-ASX.

Magnetics Module:

(Houses Output Transformers used with 140, 345, & 360-ASX power sources.)

Height: 5.25" [134 mm]; 3 rack unit
Width: 19.00" [483 mm] (front panel); 16.75" [426 mm] (chassis)
Depth: 23.50" [597 mm]
Weight: 120 lbs. [55 kg]

Refer to Figure 2.2.4 for the outline drawing of the Magnetics Module

MODEL 360-ASX

Power Source:

Height: 8.75" [222 mm]; 5 rack unit
Width: 19.00" [483 mm] (front panel); 16.75" [426 mm] (chassis)
Depth: 23.12" [587 mm] (measured from back side of front panel, excludes terminal blocks)
Weight: 125 lbs. [57 kg]

Refer to Figure 2.2.2 for the outline drawing of the Model 360-ASX.

Magnetics Module:

(Houses Output Transformers used with 140, 345, & 360-ASX power sources.)

Height: 5.25" [134 mm]; 3 rack unit
Width: 19.00" [483 mm] (front panel); 16.75" [426 mm] (chassis)
Depth: 23.50" [597 mm]
Weight: 120 lbs. [55 kg]

Refer to Figure 2.2.4 for the outline drawing of the Magnetics Module.

2.2.1 DIMENSIONS (cont.)

MODEL 3120-ASX

Power Source:

Height: 15.75" [401 mm]; 9 rack unit
Width: 19.00" [483 mm] (front panel); 17.00" [432 mm] (chassis)
Depth: 28.0" [712 mm]
Weight: 244 lbs [111 kg]

Refer to Figure 2.2.3 for the outline drawing of the Model 3120-ASX.

Magnetics Module:

Height: 7.00" [178 mm]; 4 rack unit
Width: 19.00" [483 mm] (front panel); 16.75" [426 mm] (chassis)
Depth: 25.5" [648 mm]
Weight: 280 lbs. [128 kg]

Refer to Figure 2.2.5 for the outline drawing of the Magnetics Module.

2.2.2 INPUT POWER CONNECTION

The input power is brought into the ASX-Series Power Source via the rear panel. An unterminated power cord is provided on the Models 115-ASX, 120-ASX, 140-ASX, 160-ASX, 315-ASX, 320-ASX, 345-ASX, and 360-ASX. A terminal block is provided on the Model 3120-ASX.

SECTION 2 SPECIFICATIONS

2.2.2 INPUT POWER CONNECTION (cont.)

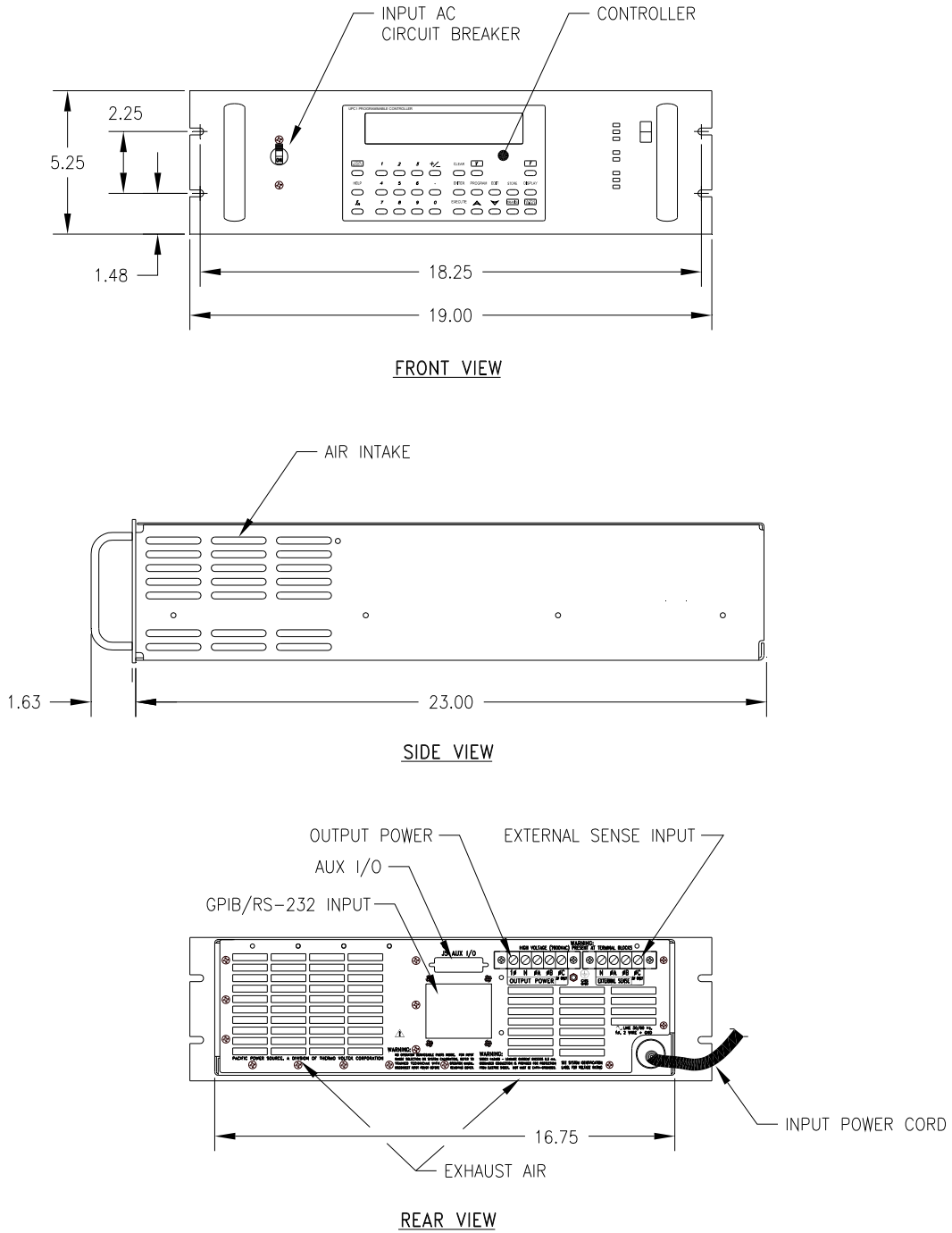

FIGURE 2.2.1 OUTLINE DRAWING, MODELS 115, 120, 315, & 320-ASX

SECTION 2 SPECIFICATIONS

2.2.2 INPUT POWER CONNECTION (cont.)

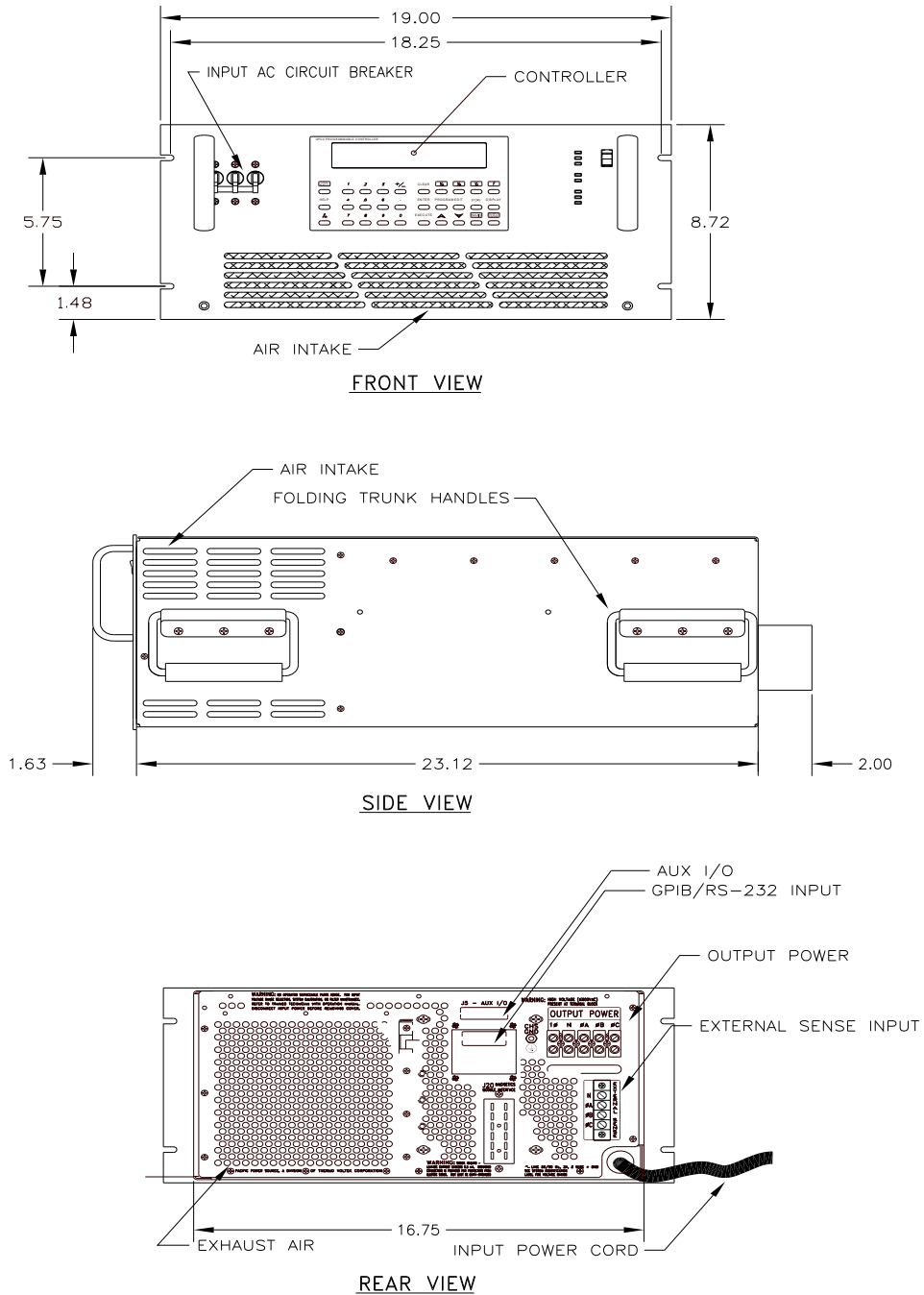

FIGURE 2.2.2 OUTLINE DRAWING, MODELS 140,160,345,360-ASX

SECTION 2 SPECIFICATIONS

2.2.2 INPUT POWER CONNECTION (cont.)

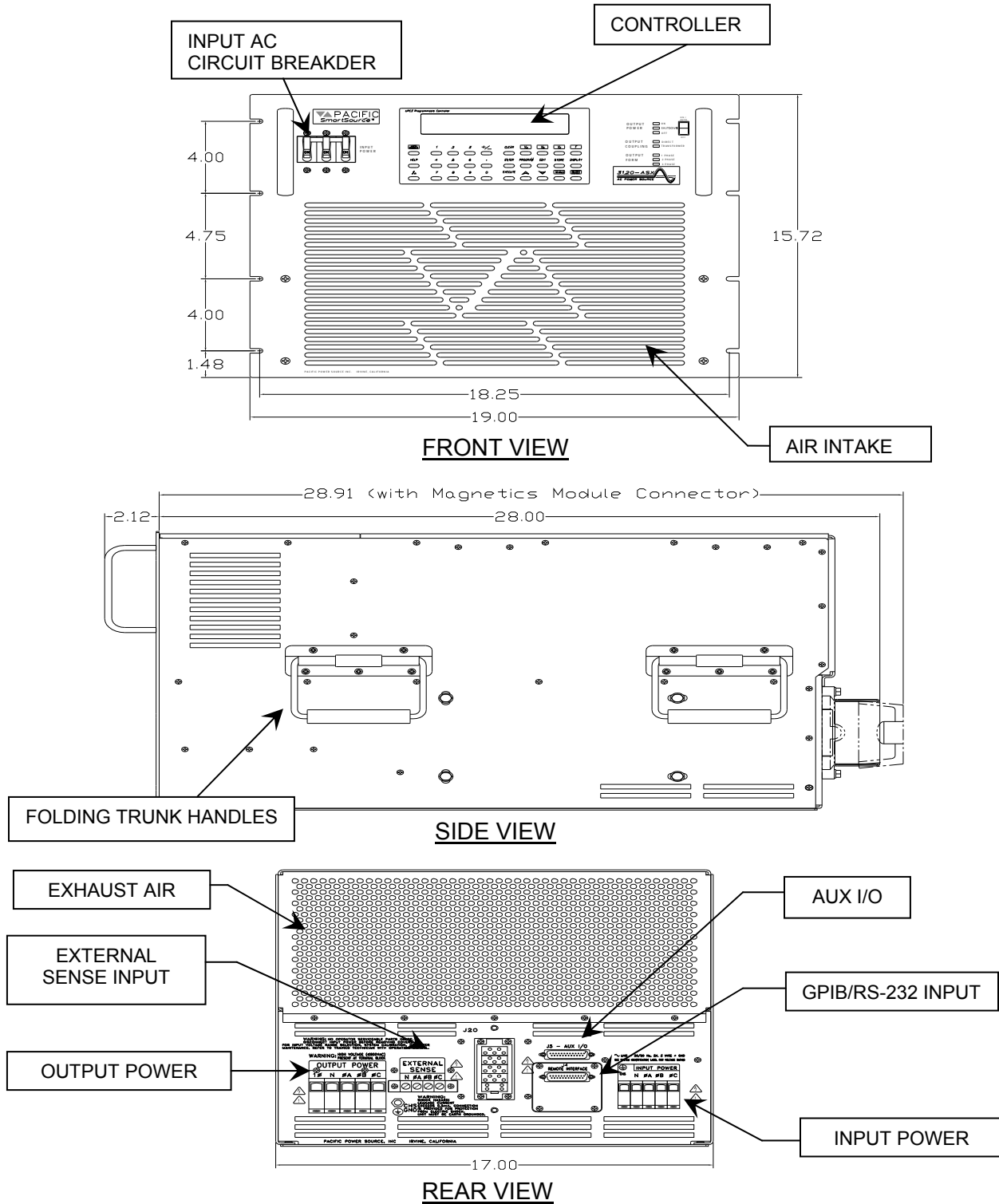

FIGURE 2.2.3 OUTLINE DRAWING, MODEL 3120-ASX

2.2.2 INPUT POWER CONNECTION (cont.)

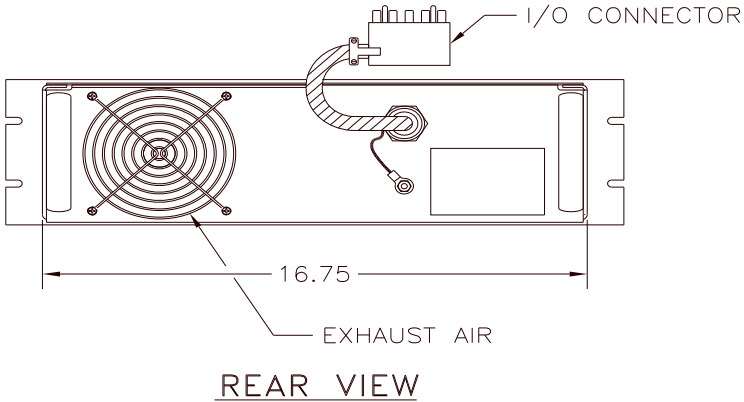
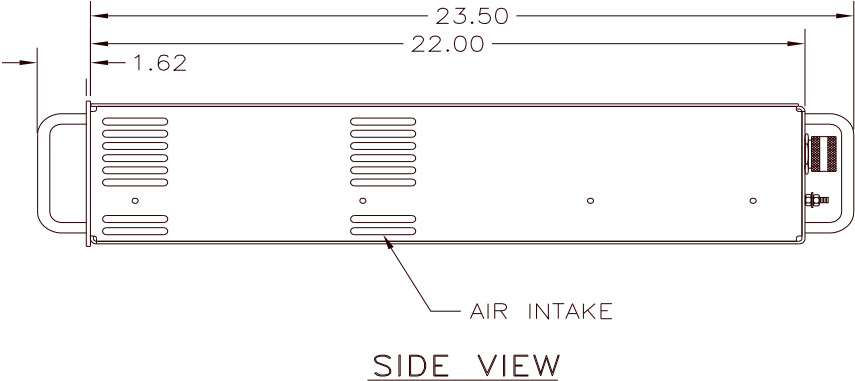
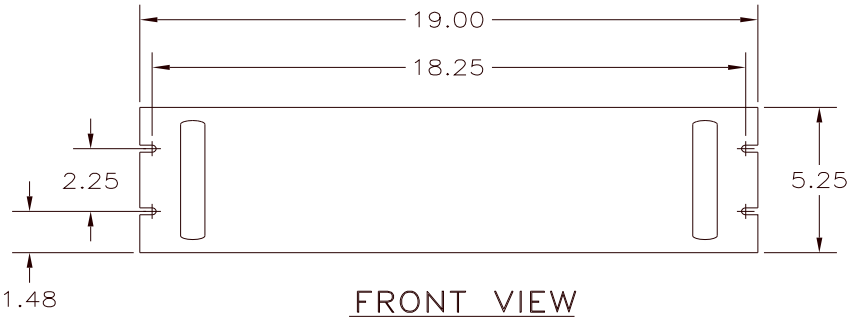

FIGURE 2.2.4 OUTLINE DRAWING, MODELS 140,160,345 & 360-ASX MAGNETICS MODULE

SECTION 2 SPECIFICATIONS

2.2.2 INPUT POWER CONNECTION (cont.)

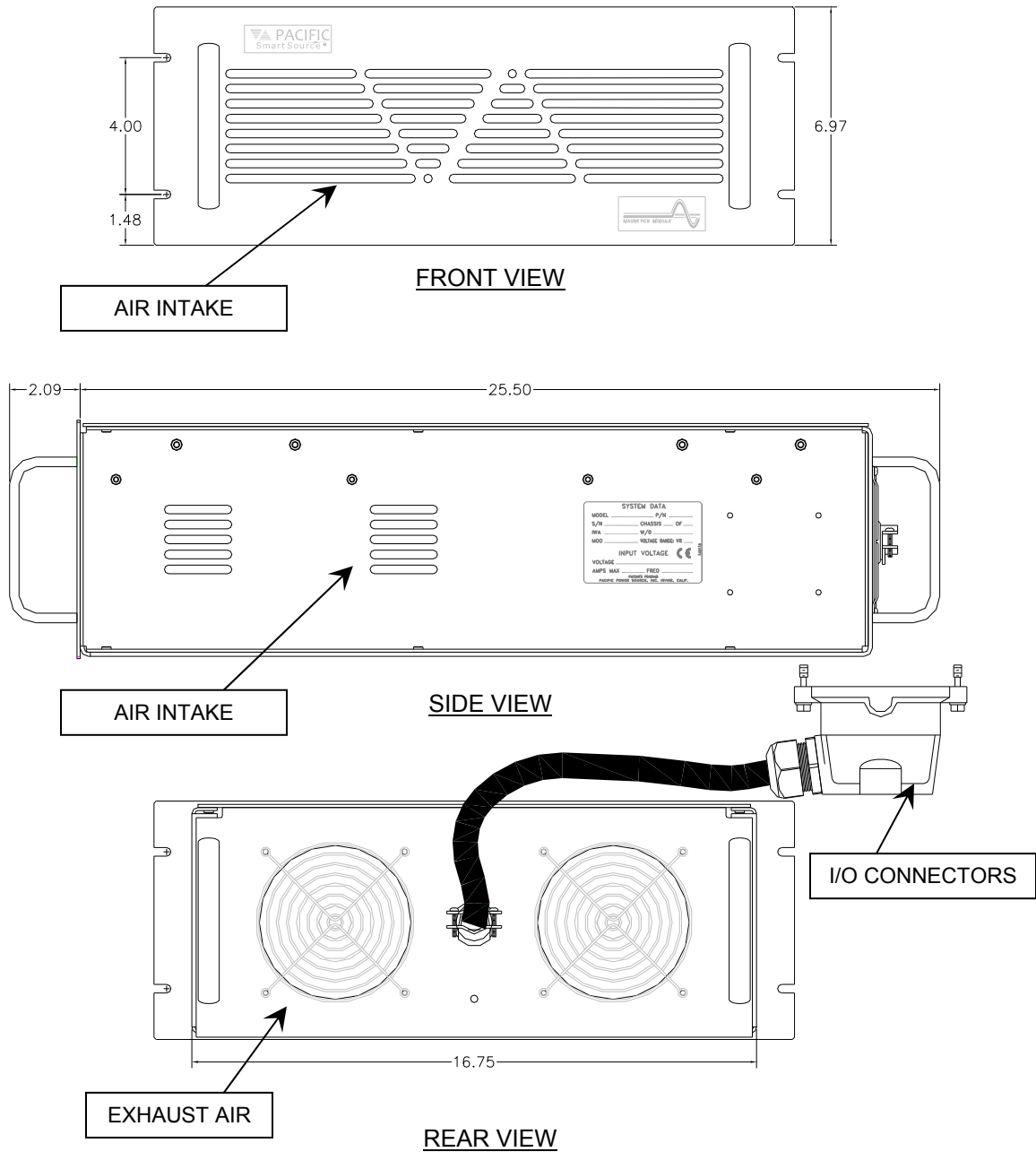

FIGURE 2.2.5 OUTLINE DRAWING, MODEL 3120-ASX MAGNETICS MODULE

2.2.3 OUTPUT POWER CONNECTION

Output power is taken from the ASX-Series Power Source via rear panel mounted terminal blocks.

2.2.4 CHASSIS SLIDE MOUNTS

The chassis of most ASX-Series Power Source models is designed to accept slide rails. These are provided as a cost option. For more information, contact your local sales representative or the Pacific Power Source Sales Office.

2.3 ENVIRONMENTAL SPECIFICATIONS

The environmental requirements of the ASX-Series Power Sources are:

2.3.1 TEMPERATURE RANGE

The ASX-Series Power Source is rated for full operation in ambient temperatures of 0 - 55°C and where the relative humidity is in the range of 0 - 95%, non-condensing.

2.3.2 COOLING

The ASX-Series Power Source utilizes thermally regulated forced-air cooling to maintain proper temperatures throughout. The maximum airflow of the 140/160/345/360-ASX Magnetics Module is 100 CFM. The maximum airflow of the Models 115-ASX, 120-ASX, 315-ASX, 320-ASX, and the 3120-ASX Magnetics Module is 200 CFM. The maximum airflow of the Models 140-ASX, 160-ASX, 345-ASX, and 360-ASX is 300 CFM. The maximum airflow of the Model 3120-ASX is 600 CFM.

2.3.3 THERMAL PROTECTION

The input power transformer is configured with a thermocouple which senses its temperature. Additionally, the power amplifier assemblies are also configured with temperature sensors. When the transformer or any power amplifier exceeds maximum safe operating temperature, the output relays are opened and the Shutdown LED, located on the front panel, is lighted.

The shutdown fault is implemented such that it must be manually reset. The fault can be reset after the over-temperature condition has ceased to exist and the Output Power Switch is placed in the "OFF" position. Sending an Output Off command via the remote interface (applies to programmable systems only) also resets the shutdown fault, provided that the condition which originally caused the shutdown has been cleared. If the Output On/Off command is sent via the remote interface and the shutdown condition has not been cleared, the power source will remain in the shutdown state until the offending condition has cleared.

SECTION 3



INSTALLATION

3 INSTALLATION

This section describes the installation of the ASX-Series AC Power Source.

3.1 CHASSIS PLACEMENT

The ASX-Series Power Source is designed to fit into the standard 19 inch rack. Provisions for mounting slide rails are included in most chassis. The ASX can also be used as a bench-top unit, if desired.

	 WARNING
<p>THE ASX-SERIES CHASSIS IS HEAVY! (VARIOUS MODELS WEIGH APPROX 70-244 lbs. [32-111kg] PER ASSY) USE EXTREME CARE WHEN MOVING THE UNIT.</p> <p>THE MAGNETICS MODULES, MODELS 140-ASX, AND 345-ASX THROUGH 3120-ASX ARE <u>NOT</u> A ONE-PERSON LIFT.</p> <p>UNIT MUST BE LIFTED BY TWO OR MORE INDIVIDUALS IN ORDER TO REDUCE CHANCE OF PHYSICAL INJURY.</p>	

-----PACKING NOTICE-----

It is the customer's responsibility to insure that units are adequately packaged when they are moved to a different location. The units should always be packaged in the original shipping container when moved or returned to the factory for service.

-----PACKING NOTICE-----

3.1 CHASSIS PLACEMENT (cont.)

The first step in setting the chassis into place is to remove it from its shipping container. The next step is to select an appropriate location for the unit. Key points to consider when locating the chassis are:

1. PROXIMITY TO THE LOAD - The power source should be located as close to the load as possible. This helps to reduce distribution losses. These losses become more critical as the output frequency increases.
2. VENTILATION - The chassis requires good ventilation to adequately cool the internal components. Airflow ranges from 100 to 600 CFM. A minimum of 12 inches front and back clearance is recommended for proper operation of the Models 140-ASX, 160-ASX, 345-ASX, 360-ASX, 3120-ASX, and the 3120-ASX Magnetics Module. The air intake for the Models 115-ASX, 120-ASX, 315-ASX, 320-ASX, and the 140/160/345/360-ASX Magnetics Module is located on both sides near the front. A minimum clearance of two inches on each side and 12 inches to the rear is required for proper operation of these models.

When the chassis is placed in a 19 inch rack, it must be supported by either chassis slides or full depth angle brackets. The front panel alone will not support the weight of the chassis. Chassis slides are available from Pacific Power Source as a cost option. Call factory service for details.

After the location for the chassis is selected, verify that the input voltage of the power source is correct (Input voltage is stated on the system ID label). If it requires changing, refer to Paragraph 3.3 for instructions.

Also check that the output voltage range is that which is desired. If not, reconfigure to the desired form as directed by Paragraph 3.2.

After the input voltage form and output voltage range have been verified as correct, slide the chassis into the rack or set it into its final position. Make input and output connections as stated in paragraphs 3.3 and 3.4, respectively.

If either the Remote Interface (GPIB or RS-232) or External Sense feature is to be used, refer to paragraphs 3.6 and 3.8 for connection

3.2 OUTPUT VOLTAGE RANGE CONFIGURATIONS

This paragraph describes the configuration of the Output Voltage Range for the ASX-Series Power Source. The ASX-Series Power Source can be configured for several different Output Voltage Ranges. The standard output configurations are:

1)	-	0-132 VAC _{I-n}	Direct-Coupled Output, standard on Models 115-ASX, 160-ASX, 315-ASX, and 360-ASX
		0-135 VAC _{I-n}	Direct-Coupled Output, standard on Models 140-ASX, 345-ASX, and 3120-ASX
		0-150 VAC _{I-n}	Direct-Coupled Output, standard on Models 120-ASX and 320-ASX
2)	VR1.5	0-198 VAC _{I-n}	Models 115-ASX, 160-ASX, 315-ASX, & 360-ASX equipped with Magnetics Option
		0-203 VAC _{I-n}	Models 140-ASX, 345-ASX & 3120-ASX equipped with Magnetics Option
3)	VR2.0	0-264 VAC _{I-n}	Models 115-ASX, 160-ASX, 315-ASX, & 360-ASX equipped with Magnetics Option
		0-270 VAC _{I-n}	Models 140-ASX, 345-ASX & 3120-ASX equipped with Magnetics Option
4)	VR2.5	0-330 VAC _{I-n}	Models 115-ASX, 160-ASX, 315-ASX, & 360-ASX equipped with Magnetics Option
		0-338 VAC _{I-n}	Models 140-ASX, 345-ASX & 3120-ASX equipped with Magnetics Option

The 0-132_{I-n}, 0-135_{I-n}, and 0-150_{I-n} VAC output ranges are direct-coupled outputs and are always available. The remaining output voltage ranges are transformer-coupled. Only one is available when output transformers are installed. However, systems can be reconfigured for a different range, if required.

Configuration of the output voltage range is set at the time of order. Systems are configured at the factory as ordered. The System ID label or Magnetics Module ID label will state the factory configured voltage range. If the output voltage range specified on the System ID label or Magnetics Module ID label is that which is desired, no further action is required. Otherwise, reconfiguration is required.

Configuration of the Output voltage consists of

- 1) Verifying that the appropriate output transformer taps have been selected.
- 2) Verifying the proper setting of the Transformer Ratio Setting within the UPC.
- 3) Verifying the proper setting of the Amps to Volts Ratio Setting within the UPC
- 4) Calibration of the system.

Configuration varies from model to model. The following paragraphs describe the configuration settings of the available standard output ranges. Refer to the appropriate paragraph for details. When custom output transformers have been installed, refer to Section 9, Modifications. The instructions stated in Section 9 take precedence over those listed in the following paragraphs.

3.2.1 OUTPUT VOLTAGE RANGE CONFIGURATION, MODEL 115-ASX

This paragraph describes the configuration of the Output Voltage Range for the Model 115-ASX Power Source. This model can be configured for either 0-132 VAC_{L-n}, 0-198 VAC_{L-n}, 0-264 VAC_{L-n}, or 0-330 VAC_{L-n}. The 0-198 VAC range is designated as the VR1.5 output form, the 0-264 VAC range is defined to be the VR2.0 output form, and the 0-330 VAC range is defined as the VR2.5 output form. An Output Transformer Assembly is required for the 198, 264, and 330 VAC output forms. Installation of the VR1.5, VR2.0, or VR2.5 output forms is performed by the factory and can be installed on existing units not so equipped.

Refer to Figure 3.2.1 for voltage range tap selection information.

TRANSFORMER RATIO

When the system is supplied with the VR1.5 output form, set the Transformer Ratio setting of the UPC-1 to 1.5. (Refer to the UPC-Series Operation Manual for details.) The Transformer Ratio setting is set to 2.0 for systems configured with the VR2.0 output form and 2.5 for systems configured for the VR2.5 output form. The Transformer Ratio setting is set to 0.0 on systems not equipped with output transformers.

AMPS TO VOLTS RATIO

The Amps to Volts Ratio Setting of the UPC-1 is always set to 4 for the Model 115-ASX. (Refer to the UPC-Series Operation Manual for details.)

SECTION 3 INSTALLATION

3.2.2 OUTPUT VOLTAGE RANGE, MODELS 115-ASX (cont.)

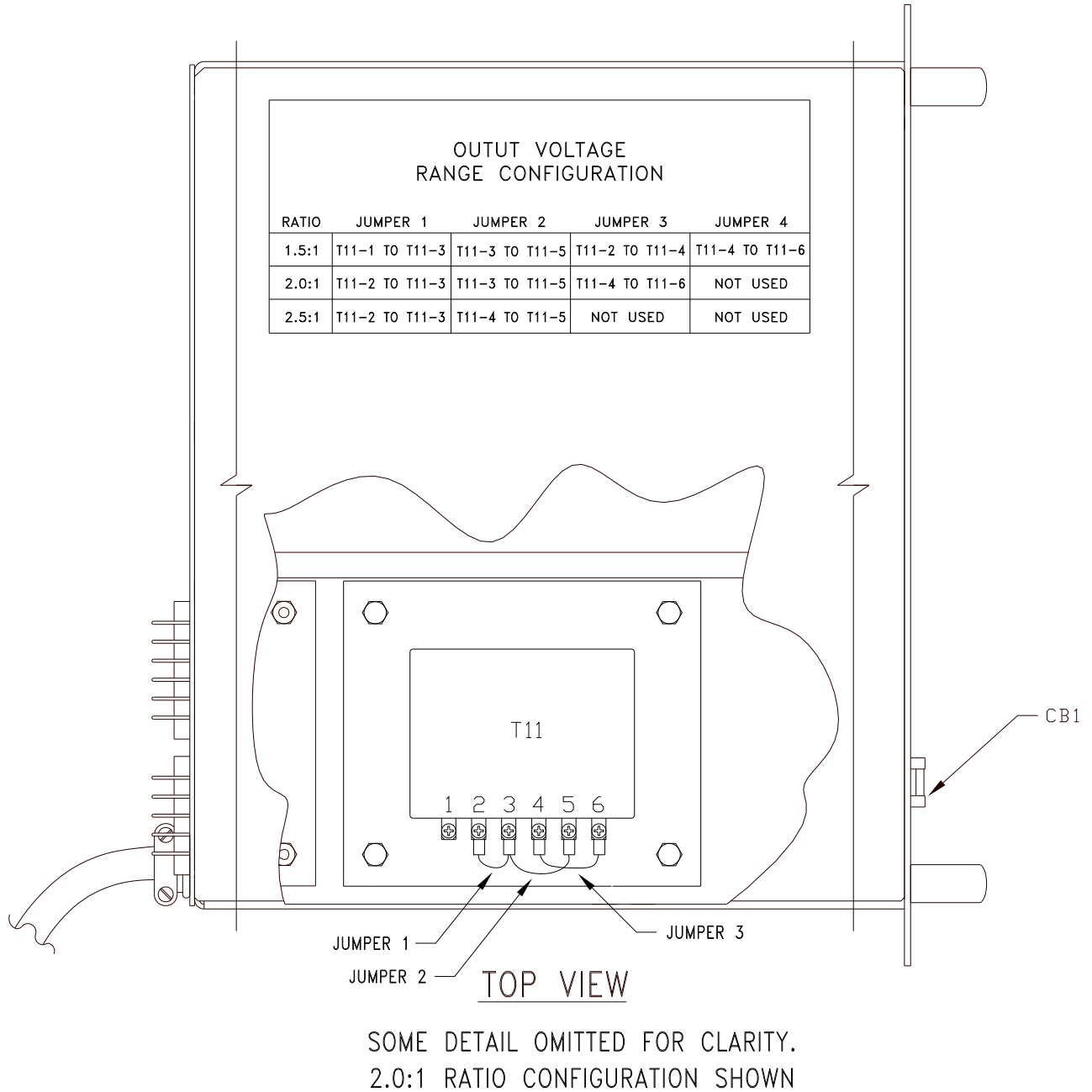

FIGURE 3.2.1 MODEL 115-ASX OUTPUT VOLTAGE RANGE CONFIGURATION

3.2.2 OUTPUT VOLTAGE RANGE, MODELS 120-ASX AND 320-ASX

The Output Voltage Range for the Models 120-ASX and 320-ASX Power Sources is 0-150 VAC_{L-n}, direct-coupled.

TRANSFORMER RATIO

The Transformer Ratio Setting of the UPC is always set to 0.0 in these models. (Refer to the UPC-Series Operation Manual for details.)

AMPS TO VOLTS RATIO

The Amps to Volts Ratio Setting of the UPC is always set to 6 in these models. (Refer to the UPC-Series Operation Manual for details.)

3.2.3 OUTPUT VOLTAGE RANGE CONFIGURATION, MODEL 315-ASX

This paragraph describes the configuration of the Output Voltage Range for the Model 315-ASX Power Source. This model can be configured for either 0-132 VAC_{L-n}, 0-198 VAC_{L-n}, 0-264 VAC_{L-n}, or 0-330 VAC_{L-n}. The 0-198 VAC range is designated as the VR1.5 output form, the 0-264 VAC range is defined to be the VR2.0 output form, and the 0-330 VAC range is defined as the VR2.5 output form. An Output Transformer Assembly is required for the 198, 264, and 330 VAC output forms. Installation of the VR1.5, VR2.0, or VR2.5 output forms is performed by the factory and can be installed on existing units not so equipped.

Refer to Figure 3.2.3 for voltage range tap selection information.

TRANSFORMER RATIO

When the system is supplied with the VR1.5 output form, set the Transformer Ratio Setting of the UPC-3 to 1.5. (Refer to the UPC-Series Operation Manual for details.) The Transformer Ratio setting is set to 2.0 for systems configured with the VR2.0 output form and 2.5 for systems configured for the VR2.5 output form. The Transformer Ratio setting is set to 0.0 on systems not equipped with output transformers.

AMPS TO VOLTS RATIO

The Amps to Volts Ratio Setting of the UPC-3 is always set to 6 for the Model 315-ASX. (Refer to the UPC-Series Operation Manual for details.)

3.2.3 OUTPUT VOLTAGE RANGE CONFIGURATION, MODEL 315-ASX (cont.)

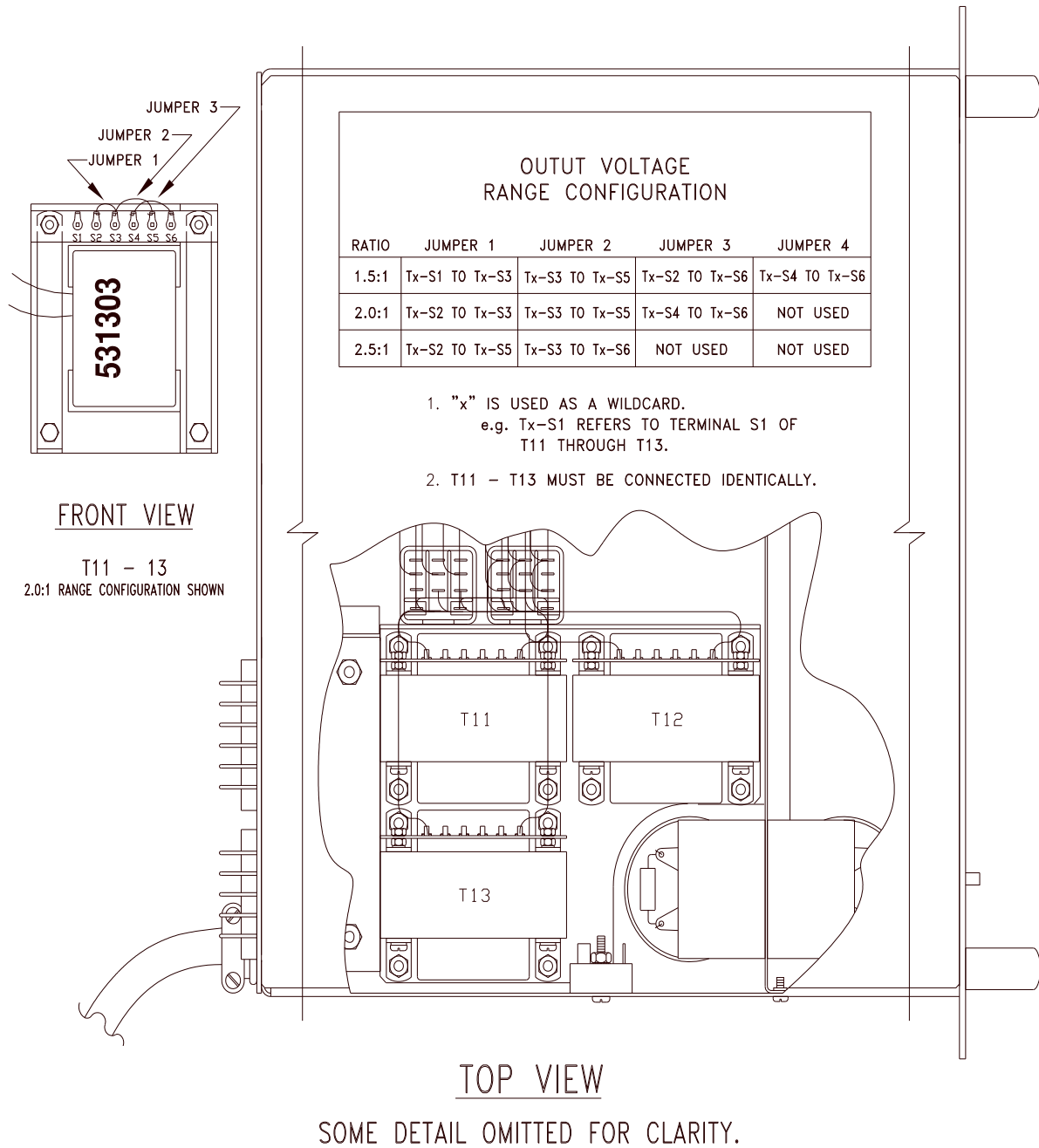

FIGURE 3.2.2 MODEL 315-ASX OUTPUT VOLTAGE RANGE CONFIGURATION

3.2.4 OUTPUT VOLTAGE RANGE CONFIGURATION, MODELS 140-ASX, 160-ASX, 345-ASX, AND 360-ASX

This paragraph describes the configuration of the Output Voltage Range for the Models 140-ASX, 345-ASX, and 360-ASX Power Sources. These models can be configured for either 0-135 VAC_{L-n} (0-132 VAC_{L-n} for Model 160/360-ASX), 0-203 VAC_{L-n} (0-198 VAC_{L-n} for Model 160/360-ASX) defined as the VR1.5 output form, 0-270 VAC_{L-n} (0-264 VAC_{L-n} for Model 160/360-ASX) defined as the VR2.0 output form, or 0-338 VAC_{L-n} (0-330 VAC_{L-n} for Model 160/360-ASX) defined as the VR2.5 output form. A Magnetics Module (Assembly No. 134310) is required for the VR1.5, VR2.0, and VR2.5 output forms.

Refer to Figure 3.2.4 for location of components referenced below and range tap selection information.

Conversion to the VR1.5 output form is as follows:

- 1) Remove the top cover of the Magnetics Module.
- 2) Wire for 1.5:1 ratio as per wire table of Figure 3.2.4.
- 3) Replace top cover of Magnetics Module.
- 4) Connect Magnetics Module to the power source. The Magnetics Module is connected to the power source by attaching P20 of the Magnetics Module to J20 of the power source. Also be sure to connect the Chassis GND wire of the Magnetics Module to the CHS GND stud on the rear panel of the power source.
- 5) Set the Transformer Ratio Setting of the UPC to 1.5. (Refer to the UPC-Series Operation Manual for details.) The Transformer Ratio Setting is set to 0.0 on systems not equipped with output transformers.
- 6) Set the Amps to Volts Ratio Setting of the UPC to 12. (Refer to the UPC-Series Operation Manual for details.)
- 7) Calibrate the power source as stated in Section 6 of this manual.

Conversion to the VR2.0 output form proceeds as above, except that the Magnetics Module is wired for the 2.0:1 ratio and the Transformer Ratio Setting of the UPC is set for 2.0.

Likewise, conversion to the VR2.5 output form proceeds as above, except that the Magnetics Module is wired for the 2.5:1 ratio and the Transformer Ratio Setting of the UPC is set for 2.5.

The Transformer Ratio Setting of the UPC is set to 0.0 on systems without transformer-coupled outputs.

While the above procedure can be performed in the field, Pacific Power Source recommends that the system be returned to the factory when transformer-coupled outputs are to be added to the system. This insures proper connection and calibration of the entire system.

SECTION 3 INSTALLATION

3.2.4 OUTPUT VOLTAGE RANGE CONFIGURATION, MODELS 140-ASX, 160-ASX, 345-ASX, AND 360-ASX (cont.)

XFMR LEAD	OUTPUT VOLTAGE RANGE CONFIGURATION		
	VR1.5	VR2.0	VR2.5
Tx-1	TBx-4B	TBx-4B	TBx-4B
Tx-2	TBx-5A	TBx-5A	TBx-5A
Tx-3	TBx-5B	TBx-5B	TBx-5B
Tx-4	TBx-6B	TBx-6B	TBx-6B
Tx-5	TBx-1B	TBx-3B	TBx-3B
Tx-6	TBx-4A	TBx-4A	TBx-4A
Tx-7	TBx-1D	TBx-1B	TBx-2B
Tx-8	TBx-4C	TBx-3A	TBx-3A
Tx-9	TBx-1A	TBx-1A	TBx-1A
Tx-10	TBx-4D	TBx-3C	TBx-2A

1. "x" IS USED AS A WILDCARD.
eg. TBx-1A REFERS TO TERMINAL 1A OF TB1 THROUGH TB6.
2. T1 - T6 MUST BE CONNECTED IDENTICALLY.

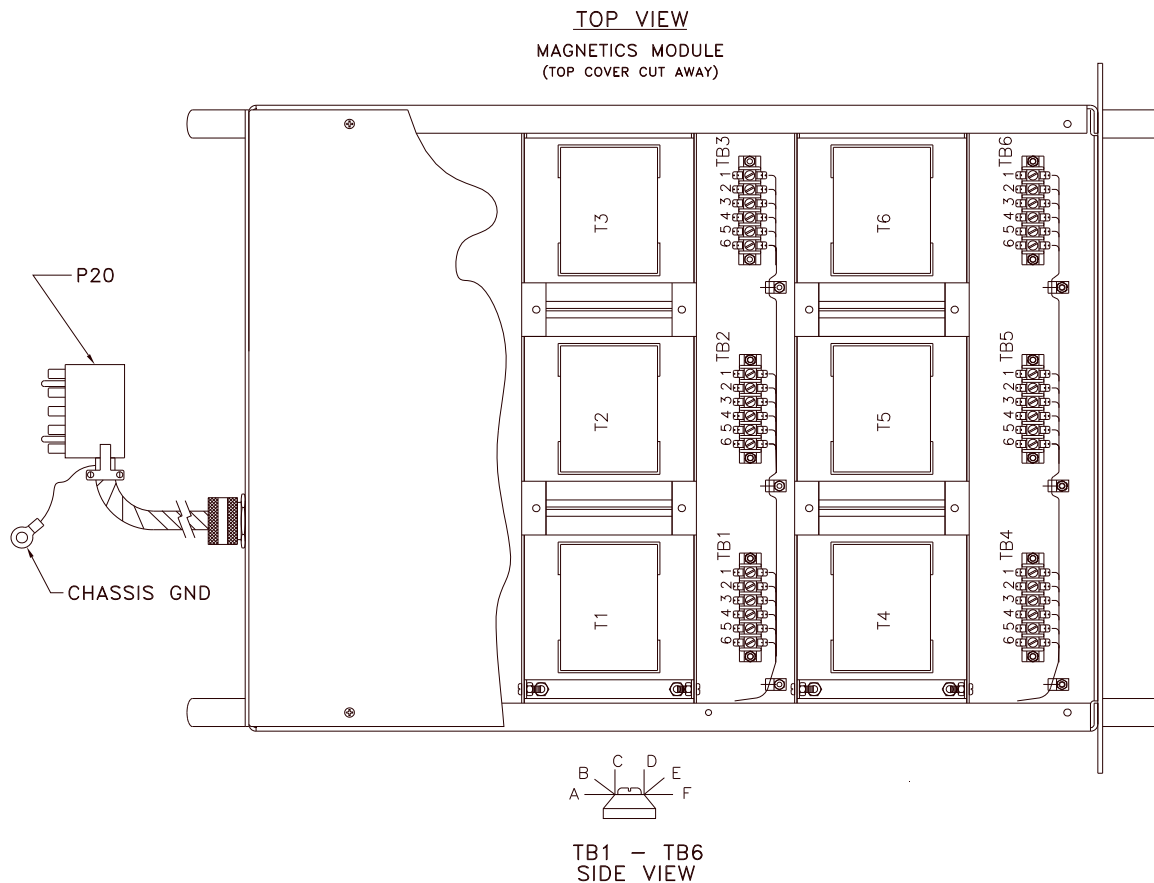

FIGURE 3.2.3 MODELS 140, 160, 345, & 360-ASX OUTPUT VOLTAGE RANGE CONFIGURATION

3.2.5 OUTPUT VOLTAGE RANGE CONFIGURATION, MODEL 3120-ASX

This paragraph describes the configuration of the Output Voltage Range for the Model 3120-ASX Power Source. This model can be configured for either 0-135 VAC_{L-n}, 0-203 VAC_{L-n}, 0-270 VAC_{L-n}, or 0-338 VAC_{L-n}. The 0-203 VAC range is designated as the VR1.5 output form. The 0-270 VAC range is defined to be the VR2.0 output form and, finally, the 0-338 VAC range is defined to be the VR2.5 output form. A Magnetics Module (Assembly No. 140700) is required for the 203, 270, and 338 VAC output forms.

Refer to Figure 3.2.5 for location of components referenced below and range tap selection information.

Conversion to the 203 VAC Output Range (VR1.5) is as follows:

- 1) Remove the top cover of the Magnetics Module.
- 2) Wire for 1.5:1 ratio as per wire table of Figure 3.2.5.
- 3) Replace top cover of Magnetics Module.
- 4) Connect Magnetics Module to the power source. The Magnetics Module is connected to the power source by attaching P20A and P20B of the Magnetics Module to J20A and J20B, respectively, of the power source. Also be sure to connect the Chassis GND wire of the Magnetics Module to the CHS GND stud on the rear panel of the power source.
- 5) Set the Transformer Ratio Setting of the UPC-3 to 1.5. (Refer to the UPC-Series Operation Manual for details.) The Transformer Ratio Setting is set to 0.0 on systems not equipped with output transformers.
- 6) Set the Amps to Volts Ratio Setting of the UPC-3 to 60. (Refer to the UPC-Series Operation Manual for details.)
- 7) Calibrate the power source as stated in Section 6 of this manual.

Conversion to the 270 VAC Output Range (VR2.0) proceeds as above, except that the Magnetics Module is wired for the 2.0:1 ratio and the Transformer Ratio Setting of the UPC-3 is set for 2.0.

Likewise, conversion to the 338 VAC Output Range (VR2.5) proceeds as above, except that the Magnetics Module is wired for the 2.5:1 ratio and the Transformer Ratio Setting of the UPC-3 is set for 2.5.

The Transformer Ratio Setting of the UPC-3 is set to 0.0 on systems without transformer-coupled outputs.

While the above procedure can be performed in the field, Pacific Power Source recommends that the system be returned to the factory when transformer-coupled outputs are to be added to the system. This insures proper connection and calibration of the entire system.

SECTION 3 INSTALLATION

3.2.5 OUTPUT VOLTAGE RANGE CONFIGURATION, MODEL 3120-ASX (cont.)

OUTPUT VOLTAGE RANGE CONFIGURATION

XFMER LEAD	VR 1.5	VR 2.0	VR 2.5
Tx - 1	TBx - A5	TBx - A5	TBx - A5
Tx - 2	TBx - D6	TBx - C5	TBx - B4
Tx - 3	TBx - A4	TBx - A4	TBx - B3
Tx - 4	TBx - D5	TBx - C4	TBx - C4
Tx - 5	TBx - A3	TBx - C3	TBx - C3
Tx - 6	TBx - D4	TBx - D4	TBx - D4
Tx - 7	TBx - D3	TBx - D3	TBx - D3
Tx - 8	TBx - E4	TBx - E4	TBx - E4
Tx - 9	TBx - E3	TBx - E3	TBx - E3
Tx - 10	TBx - F4	TBx - F4	TBx - F4

1. 'x' IS USED AS A WILDCARD.
(e.g. TBx-A5 REFERS TO TERMINAL A5 OF TB1 THROUGH TB6)
2. T1 THROUGH T6 MUST BE CONNECTED IDENTICALLY

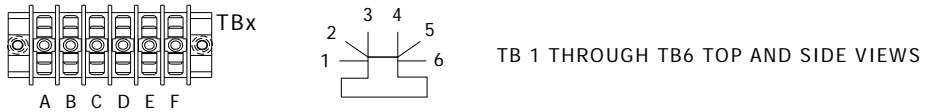

12KVA MAGNETICS MODULE
TOP VIEW
(TOP COVER CUT AWAY)

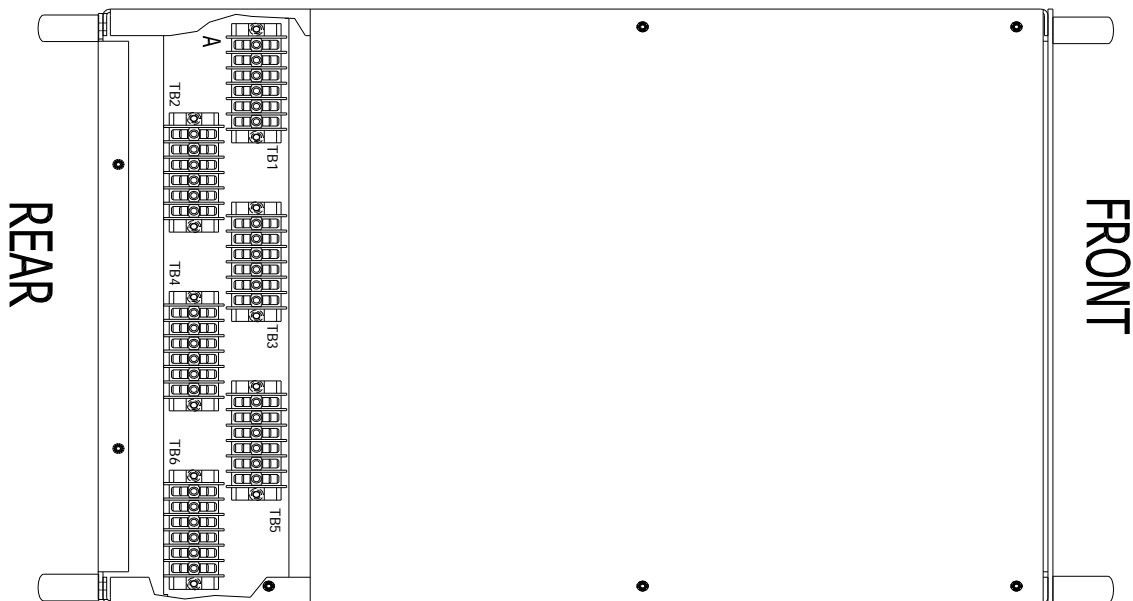

FIGURE 3.2.4 MODEL 3120-ASX OUTPUT VOLTAGE RANGE CONFIGURATION

3.3 INPUT POWER CONNECTION

This paragraph describes configuration of input voltage form and requirements of the input wiring for the ASX-Series Power Source. Since each model varies, each is discussed in a separate paragraph. Please refer to the appropriate paragraph for the model being configured.

3.3.1 INPUT VOLTAGE CONFIGURATION, MODEL 115-ASX

WARNING

DISCONNECT THIS UNIT FROM THE INPUT SERVICE BEFORE REMOVING TOP COVER.

HIGH VOLTAGE HAZARD PRESENT INSIDE UNIT WHEN TOP COVER IS REMOVED
AND STILL CONNECTED TO INPUT SERVICE.

The 115-ASX Power Source has been designed to accept most standard single phase input voltage forms. This is accomplished through the use of a tapped, dual primary, input power transformer. Configuring the proper input form is simply a matter of setting jumpers in the appropriate positions. The system is designed for use with input frequencies of 47 to 63 Hz. (Optionally, the system may be used with input frequencies of up to 440 Hz. Contact the factory for details.)

Figure 3.3.1 shows the location of the various jumpers which need attention relative to input voltage form. The position of these jumpers is listed on the accompanying table.

The first step in configuring the input power form is to remove the top cover. Next, connect the jumpers as stated in the table for the desired input voltage. Jumpers are located on the input power transformer (T1). Refer to the table in Figure 3.3.1 for the proper setting.

After configuring the input voltage form, check connections and insure that they are tight and in the correct position. Replace the top cover.

CAUTION

CONNECTION OF THIS UNIT TO IMPROPER INPUT VOLTAGES WILL CAUSE CATASTROPHIC
DAMAGE TO THE POWER SOURCE.

READ THE INPUT VOLTAGE LABEL AND CONNECT TO THAT INPUT VOLTAGE ONLY. IF THERE ARE ANY
QUESTIONS, CONTACT THE FACTORY

The ASX-Series Power Source is then connected to an appropriate outlet via the input power cord. Refer to Paragraph 2.1.1 for minimum input service requirements of the various input voltage forms.

SECTION 3 INSTALLATION

3.3.1 INPUT VOLTAGE CONFIGURATION, MODEL 115-ASX (cont.)

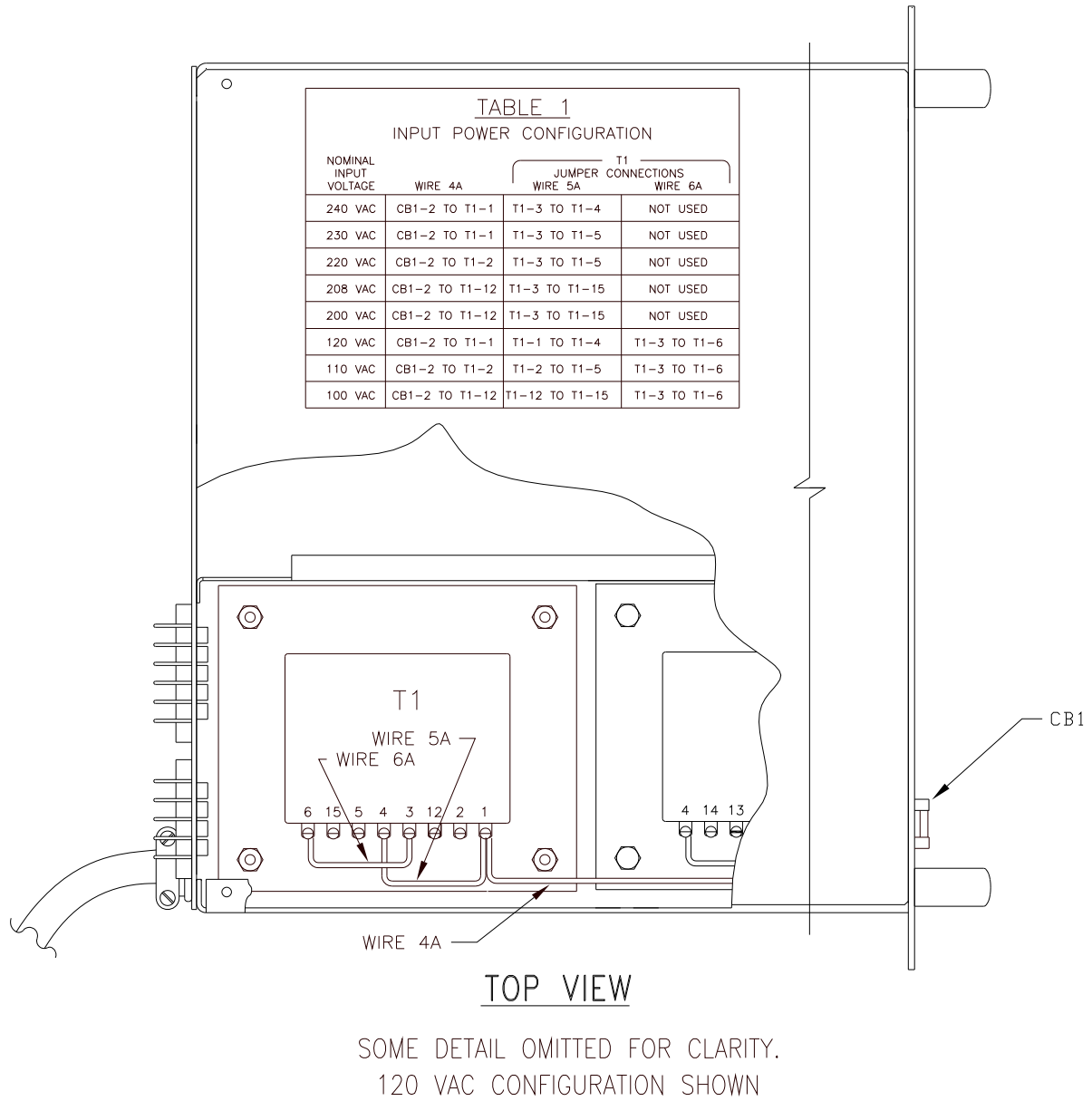

FIGURE 3.3.1 MODEL 115-ASX INPUT VOLTAGE CONFIGURATION

3.3.2 INPUT VOLTAGE CONFIGURATION, MODELS 120-ASX AND 320-ASX**WARNING**

DISCONNECT THIS UNIT FROM THE INPUT SERVICE BEFORE REMOVING TOP COVER.

HIGH VOLTAGE HAZARD PRESENT INSIDE UNIT WHEN TOP COVER IS REMOVED AND STILL CONNECTED TO INPUT SERVICE.

The 120-ASX and 320-ASX Power Sources have been designed to accept most standard single phase input voltage forms. This is accomplished through the use of a tapped, dual primary, input power transformer. Configuring the proper input form is simply a matter of setting jumpers in the appropriate positions. The system is designed for use with input frequencies of 47 to 63 Hz.

Figure 3.3.2 shows the location of the various jumpers which need attention relative to input voltage form. The position of these jumpers is listed on the accompanying table.

The first step in configuring the input power form is to remove the top cover. Next, connect the jumpers as stated in the table for the desired input voltage. Jumpers are located on the the input power transformer (T1). Refer to the table in Figure 3.3.2 for the proper setting.

After configuring the input voltage form, check connections and insure that they are tight and in the correct position. Replace the top cover.

**CAUTION**

CONNECTION OF THIS UNIT TO IMPROPER INPUT VOLTAGES WILL CAUSE CATASTROPHIC DAMAGE TO THE POWER SOURCE.

READ THE INPUT VOLTAGE LABEL AND CONNECT TO THAT INPUT VOLTAGE ONLY. IF THERE ARE ANY QUESTIONS, CONTACT THE FACTORY.

The 120-ASX or 320-ASX is then connected to an appropriate outlet via the input power cord. Refer to Paragraph 2.1.1 for minimum input service requirements of the various input voltage forms.

SECTION 3 INSTALLATION

3.3.2 INPUT VOLTAGE CONFIGURATION, MODELS 120-ASX AND 320-ASX (cont.)

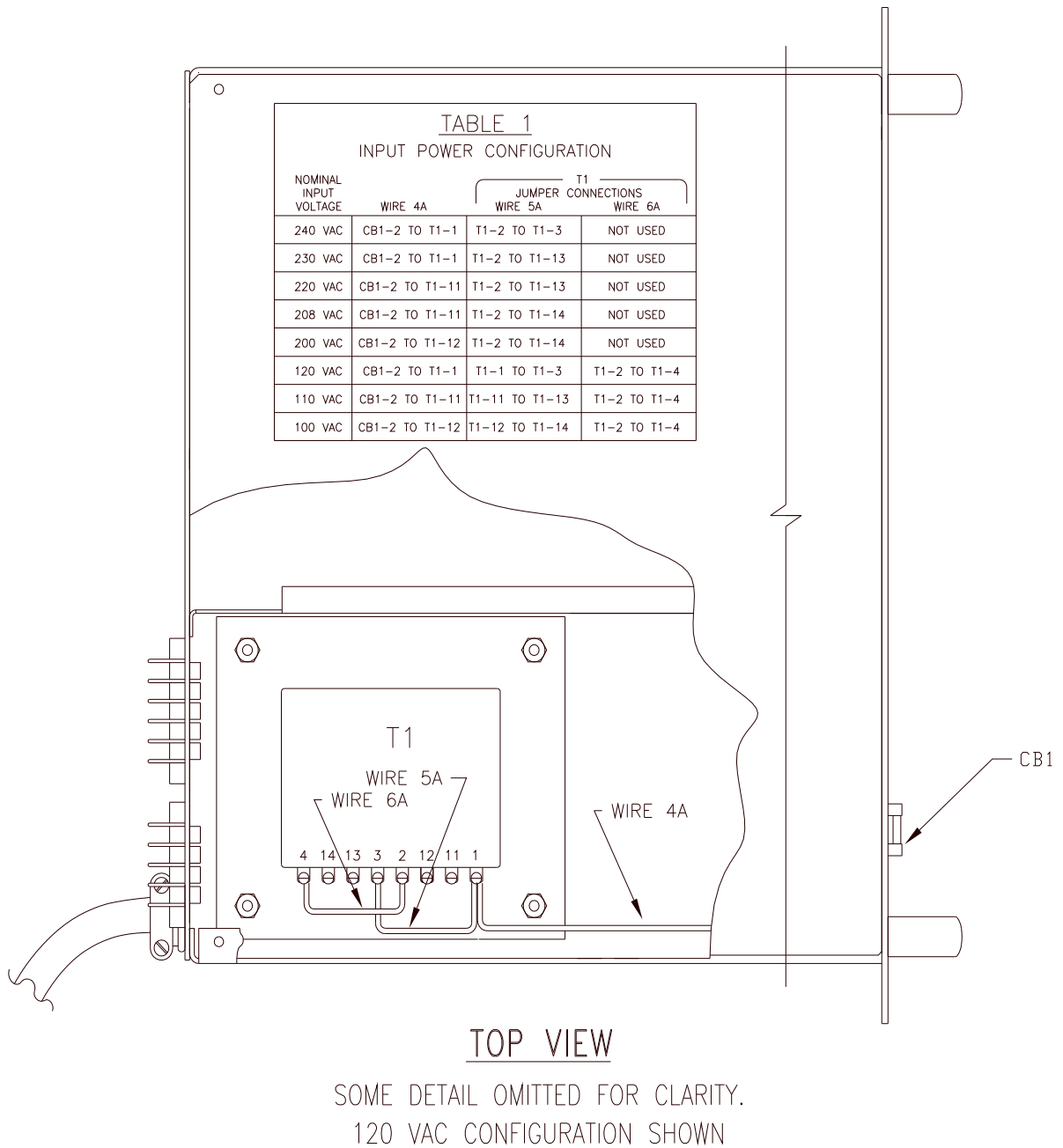

FIGURE 3.3.2 MODELS 120-ASX AND 320-ASX INPUT VOLTAGE CONFIGURATION

3.3.3 INPUT VOLTAGE CONFIGURATION, MODEL 315-ASX



WARNING

DISCONNECT THIS UNIT FROM THE INPUT SERVICE BEFORE REMOVING TOP COVER.

HIGH VOLTAGE HAZARD PRESENT INSIDE UNIT WHEN TOP COVER IS REMOVED AND STILL CONNECTED TO INPUT SERVICE.

The 315-ASX Power Source has been designed to accept most standard single phase input voltage forms. This is accomplished through the use of a tapped, dual primary, input power transformer. Configuring the proper input form is simply a matter of setting jumpers in the appropriate positions. The system is designed for use with input frequencies of 47 to 63 Hz. (Optionally, the system may be used with input frequencies of up to 440 Hz. Contact the factory for details.)

Figure 3.3.3 shows the location of the various jumpers which need attention relative to input voltage form. The position of these jumpers is listed on the accompanying table.

The first step in configuring the input power form is to remove the top cover. Next, connect the jumpers as stated in the table for the desired input voltage. Jumpers are located on the input power transformer (T1). Refer to the table in Figure 3.3.3 for the proper setting.

After configuring the input voltage form, check connections and insure that they are tight and in the correct position. Replace the top cover.



CAUTION

CONNECTION OF THIS UNIT TO IMPROPER INPUT VOLTAGES WILL CAUSE CATASTROPHIC DAMAGE TO THE POWER SOURCE.

READ THE INPUT VOLTAGE LABEL AND CONNECT TO THAT INPUT VOLTAGE ONLY.
IF THERE ARE ANY QUESTIONS, CONTACT THE FACTORY.

SECTION 3 INSTALLATION

3.3.3 INPUT VOLTAGE CONFIGURATION, MODEL 315-ASX (cont.)

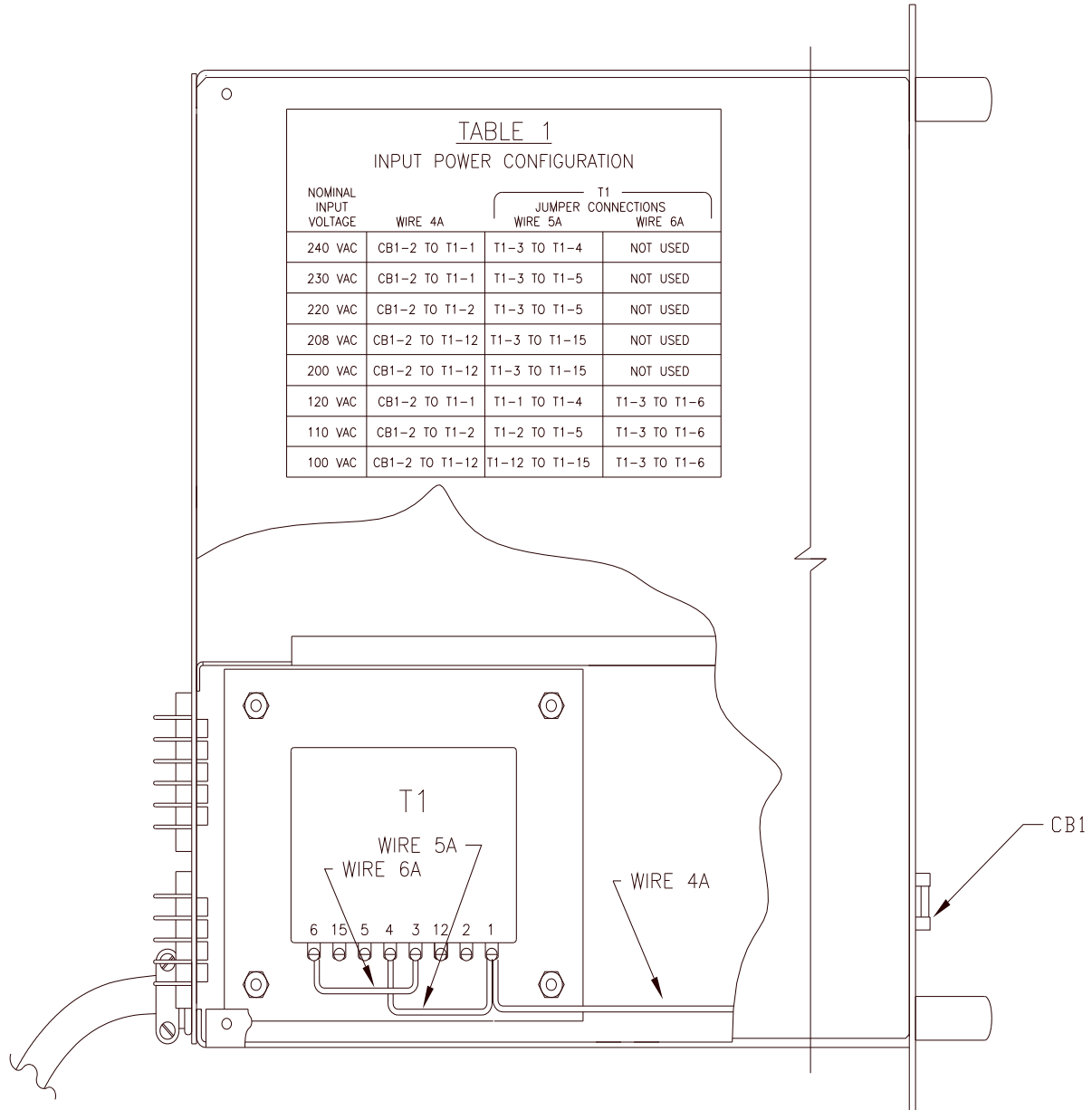

TOP VIEW

SOME DETAIL OMITTED FOR CLARITY.
120 VAC CONFIGURATION SHOWN

FIGURE 3.3.3 MODEL 315-ASX INPUT VOLTAGE CONFIGURATION

3.3.4 INPUT VOLTAGE CONFIGURATION, MODELS 140, 160, 345, AND 360-ASX**WARNING**

DISCONNECT THIS UNIT FROM THE INPUT SERVICE BEFORE REMOVING TOP COVER.
HIGH VOLTAGE HAZARD PRESENT INSIDE UNIT WHEN TOP COVER IS REMOVED AND STILL
CONNECTED TO INPUT SERVICE

The 140-ASX, 160-ASX, 345-ASX, and 360-ASX Power Sources have been designed to accept most standard three phase input voltage forms. This is accomplished through the use of a tapped input power transformer. Configuring the proper input form is simply a matter of setting jumpers in the appropriate positions. The system is designed for use with input frequencies of 47 to 63 Hz. (Optionally, systems may be used with input frequencies of up to 440 Hz. Contact the factory for details.)

Figure 3.3.4 shows the location of the various jumpers which need attention relative to input voltage form. The position of these jumpers is listed on the accompanying table.

The first step in configuring the input power form is to remove the top cover. Next, connect the jumpers as stated in the table for the desired input voltage. Refer to the table in Figure 3.3.4 for the proper setting.

After configuring the input voltage form, check connections and insure that they are tight and in the correct position. Replace the top cover.

**CAUTION**

CONNECTION OF THIS UNIT TO IMPROPER INPUT VOLTAGES WILL CAUSE
CATASTROPHIC DAMAGE TO THE POWER SOURCE.

READ THE INPUT VOLTAGE LABEL AND CONNECT TO THAT INPUT VOLTAGE ONLY. IF
THERE ARE ANY QUESTIONS, CONTACT THE FACTORY.

The 140-ASX, 345-ASX, or 360-ASX is then connected to an appropriate distribution panel via the input power cord. Refer to Paragraph 2.1.1 for minimum input service requirements of the various input voltage forms.

SECTION 3 INSTALLATION

3.3.4 INPUT VOLTAGE CONFIGURATION, MODELS 140,160, 345 AND 360-ASX (cont.)

NOMINAL INPUT VOLTAGE	T1 JUMPER CONNECTIONS		
	WIRE 1C	WIRE 2C	WIRE 3C
277/480 VAC	REFER TO SECTION 9, MODIFICATIONS		
240/416 VAC	T1-B4 TO T1-A4	T1-C4 TO T1-B4	T1-A4 TO T1-C4
230/400 VAC	T1-B5 TO T1-A5	T1-C5 TO T1-B5	T1-A5 TO T1-C5
220/380 VAC	T1-B3 TO T1-A3	T1-C3 TO T1-B3	T1-A3 TO T1-C3
240 VAC DELTA	T1-B4 TO T1-A1	T1-C4 TO T1-B1	T1-A4 TO T1-C1
220 VAC DELTA	T1-B3 TO T1-A1	T1-C3 TO T1-B1	T1-A3 TO T1-C1
208 VAC DELTA	T1-B2 TO T1-A1	T1-C2 TO T1-B1	T1-A2 TO T1-C1

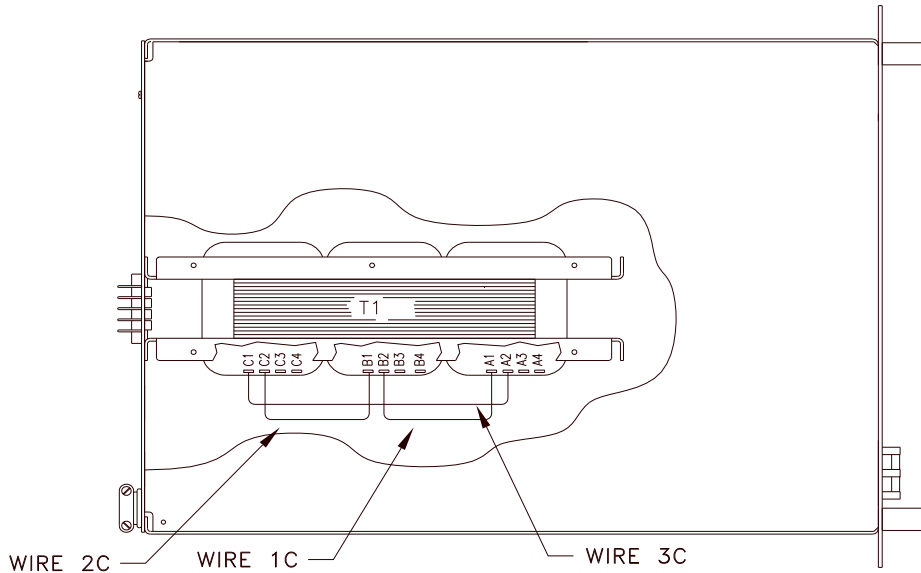

TOP VIEW

SOME DETAIL OMITTED FOR CLARITY
208 DELTA CONFIGURATION SHOWN

FIGURE 3.3.4 MODELS 140, 160, 345, AND 360-ASX INPUT VOLTAGE CONFIGURATION

3.3.5 INPUT VOLTAGE CONFIGURATION, MODEL 3120-ASX**WARNING**

DISCONNECT THIS UNIT FROM THE INPUT SERVICE BEFORE REMOVING TOP COVER.

HIGH VOLTAGE HAZARD PRESENT INSIDE UNIT WHEN TOP COVER IS REMOVED AND STILL CONNECTED TO INPUT SERVICE.

The 3120-ASX Power Source has been designed to accept most standard three phase input voltage forms. This is accomplished through the use of a tapped input power transformer. Configuring the proper input form is simply a matter of setting jumpers in the appropriate positions. The system is designed for use with input frequencies of 47 to 63 Hz. (Optionally, systems may be used with input frequencies of up to 440 Hz. Contact the factory for details.)

Figure 3.3.5 shows the location of the various jumpers which need attention relative to input voltage form. The position of these jumpers is listed on the accompanying table.

The first step in configuring the input power form is to remove the top cover. Next, connect the jumpers as stated in the table for the desired input voltage. Refer to the table in Figure 3.3.5 for the proper setting.

After configuring the input voltage form, check connections and insure that they are tight and in the correct position. Replace the top cover.

**CAUTION**

CONNECTION OF THIS UNIT TO IMPROPER INPUT VOLTAGES WILL CAUSE CATASTROPHIC DAMAGE TO THE POWER SOURCE.

READ THE INPUT VOLTAGE LABEL AND CONNECT TO THAT INPUT VOLTAGE ONLY. IF THERE ARE ANY QUESTIONS, CONTACT THE FACTORY.

The 3120-ASX is then connected to an appropriate distribution panel via the Input Power terminal block. Refer to Paragraph 2.1.1 for minimum input service requirements of the various input voltage forms.

SECTION 3 INSTALLATION

3.3.5 INPUT VOLTAGE CONFIGURATION, MODEL 3120-ASX (cont.)

TABLE 1

INPUT VOLTAGE FORM	FROM HARNESS	JUMPERS XFMR TO XFMR
208 VAC DELTA	(ØA) WIRE TO T1-A1 (ØB) WIRE TO T1-B1 (ØC) WIRE TO T1-C1	JUMPER T1-A1 TO T1-C2 JUMPER T1-B1 TO T1-A2 JUMPER T1-C1 TO T1-B2
220 VAC DELTA	(ØA) WIRE TO T1-A1 (ØB) WIRE TO T1-B1 (ØC) WIRE TO T1-C1	JUMPER T1-A1 TO T1-C3 JUMPER T1-B1 TO T1-A3 JUMPER T1-C1 TO T1-B3
230 VAC DELTA	(ØA) WIRE TO T1-A1 (ØB) WIRE TO T1-B1 (ØC) WIRE TO T1-C1	JUMPER T1-A1 TO T1-C4 JUMPER T1-B1 TO T1-A4 JUMPER T1-C1 TO T1-B4
240 VAC DELTA	(ØA) WIRE TO T1-A1 (ØB) WIRE TO T1-B1 (ØC) WIRE TO T1-C1	JUMPER T1-A1 TO T1-C5 JUMPER T1-B1 TO T1-A5 JUMPER T1-C1 TO T1-B5
220 / 380 VAC	(ØA) WIRE TO T1-A1 (ØB) WIRE TO T1-B1 (ØC) WIRE TO T1-C1	JUMPER T1-A3 TO T1-C3 JUMPER T1-B3 TO T1-A3 JUMPER T1-C3 TO T1-B3
230 / 400 VAC	(ØA) WIRE TO T1-A1 (ØB) WIRE TO T1-B1 (ØC) WIRE TO T1-C1	JUMPER T1-A4 TO T1-C4 JUMPER T1-B4 TO T1-A4 JUMPER T1-C4 TO T1-B4
240 / 416 VAC	(ØA) WIRE TO T1-A1 (ØB) WIRE TO T1-B1 (ØC) WIRE TO T1-C1	JUMPER T1-A5 TO T1-C5 JUMPER T1-B5 TO T1-A5 JUMPER T1-C5 TO T1-B5
277 / 480 VAC	(ØA) WIRE TO T1-A1 (ØB) WIRE TO T1-B1 (ØC) WIRE TO T1-C1	JUMPER T1-A6 TO T1-C6 JUMPER T1-B6 TO T1-A6 JUMPER T1-C6 TO T1-B6

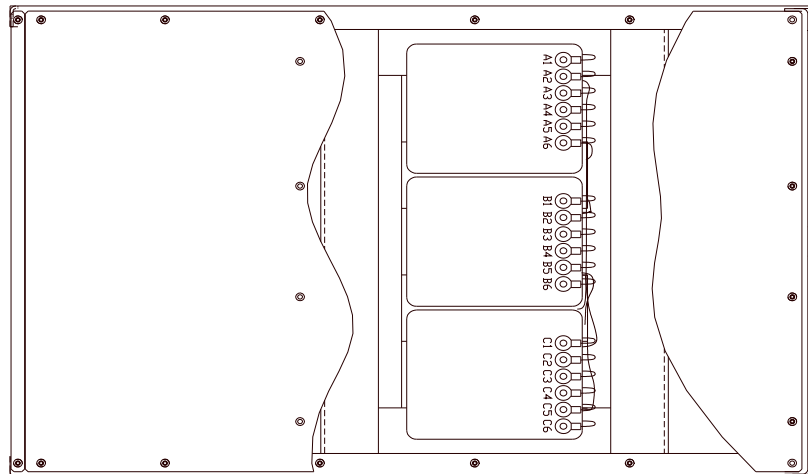

BOTTOM VIEW
(BOTTOM COVER CUT AWAY)

1. SOME DETAIL OMITTED FOR CLARITY
NOTES:

FIGURE 3.3.5 MODEL 3120-ASX INPUT VOLTAGE CONFIGURATION

3.3.6 INPUT POWER WIRING REQUIREMENTS



WARNING

LETHAL VOLTAGE PRESENT AT INPUT TERMINALS OF THIS MACHINE.

ALWAYS CONNECT "CHS or GND" TERMINAL TO EARTH POTENTIAL.
FAILURE TO DO SO WILL CREATE A SHOCK HAZARD.

The Models 115-ASX, 120-ASX, 140-ASX, 160-ASX, 315-ASX, 320-ASX, 345-ASX, and 360-ASX are supplied with an input power cord. Install an appropriate plug onto the end of the power cord and connect to the proper outlet. Refer to the table below for the proper wire color of each connection. The Power Sources with 3 phase input are not sensitive to phase rotation of the input voltage. Refer to paragraph 2.1.1 for recommended input service of the configured input voltage form.

		Wire Color(US Models)	Wire Color(European Models)
1 ϕ ←	LINE (HI)	Black	Brown
	NEUTRAL (LO)	White	Blue
	GROUND (CHS)	Green	Green-Yellow
3 ϕ ←	LINE 1 (L1)	Black	Brown
	LINE 2 (L2)	Orange	Black
	LINE 3 (L3)	Red	Grey

The input power of the Model 3120-ASX connects to the Input Power terminal block located on the rear panel of the power source. The connection points are labeled "A," "B," "C," "N," and "CHS". The input wiring is connected to these points in the appropriate order with CHS being the safety ground or earth potential. The 3120-ASX Power Source is not sensitive to phase rotation of the input voltage. For all standard DELTA input voltage forms (208, 220, and 240 VAC) the "N" terminal is not used. For WYE input voltage forms (220/380, 240/416 and 277/480 VAC), the "N" terminal connection is optional. Refer to Figure 3.3.9 for the proper wire size to be used with the configured input power form.



CAUTION

CONNECTION OF THIS UNIT TO IMPROPER INPUT VOLTAGES WILL CAUSE
CATASTROPHIC DAMAGE TO THE POWER SOURCE.

READ THE INPUT VOLTAGE LABEL AND CONNECT TO THAT INPUT VOLTAGE ONLY. IF
THERE ARE ANY QUESTIONS, CONTACT THE FACTORY.

NOTE: It is the user's responsibility to meet all local and national electrical codes when installing this equipment.

SECTION 3 INSTALLATION

3.3.6 INPUT POWER WIRING REQUIREMENTS (cont.)

WIRE TABLE

INPUT VOLTAGE FORM	MINIMUM WIRE SIZE
208 VAC DELTA	10 AWG THWN OR SO-8-4
220 VAC DELTA	10 AWG THWN OR SO-8-4
240 VAC DELTA	10 AWG THWN OR SO-8-4
220/380 VAC	12 AWG THWN OR SO-10-5
240/416 VAC	12 AWG THWN OR SO-10-5
277/480 VAC	12 AWG THWN OR SO-10-5

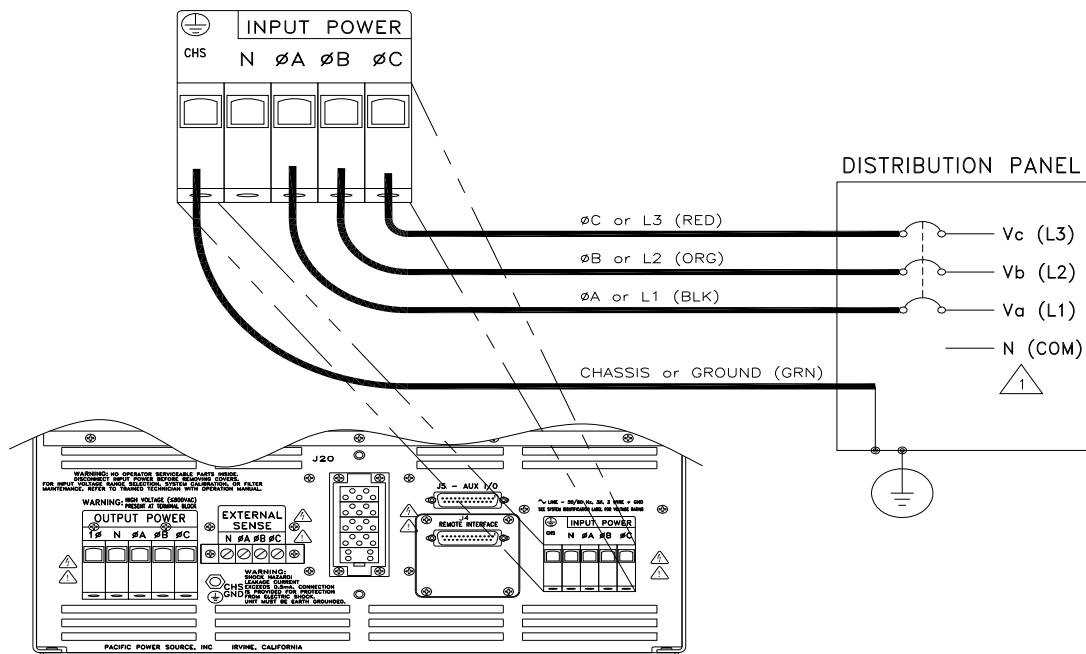

REAR VIEW

2. WIRE SIZES BASED ON TABLE 310-16 OF THE 1990 NATIONAL ELECTRIC CODE (NEC).

1. NEUTRAL WIRE IS NOT USED.

NOTES

FIGURE 3.3.6 3120-ASX INPUT WIRING DIAGRAM

3.4 OUTPUT POWER CONNECTION

This paragraph describes connection of the load to the ASX-Series Power Source.

3.4.1 SINGLE PHASE OUTPUT



To operate an ASX-Series power source with single phase output, set the controller for FORM1. Figures 3.4.1.1 and 3.4.1.2 show a single phase load connected to the output of an ASX-Series Power Source.

The output power is taken from the terminal block located on the rear panel of the chassis labeled "OUTPUT POWER". The Output Form is set for 1 PHASE when this type of load is attached.

This power form has a direct-coupled voltage range of 0-132 VAC_{i-n} (Models 115-ASX, 160-ASX, 315-ASX, & 360-ASX), 0-135 VAC_{i-n} (Models 140-ASX, 345-ASX, & 3120-ASX), or 0-150 VAC_{i-n} (Models 120-ASX and 320-ASX). The high side of the load is connected to the "1 ϕ " terminal and the low side of the load to the "N" terminal.

For safe operation, the "CHS" terminal should always be connected to the chassis of the load. Since the output is isolated, either output terminal (direct-coupled output only) may be connected to chassis. This allows the user to re-establish a local ground for the output. The output (preferably Neutral) should be referenced to chassis somewhere. Unless demanded by a particular application, Pacific Power Source recommends that a jumper be installed across the "N" and "CHS" terminals of the Output Terminal block.

The "N" terminal of the Output Power Terminal Block must always be connected to the "CHS" terminal when using transformer-coupled outputs. Refer to Paragraph 3.4.4 for special considerations when using transformer-coupled output forms.

Refer to Paragraph 3.8 for connection of the External Sense Input, when used.

NOTE: It is the user's responsibility to meet all local and national electrical codes when installing this equipment.

SECTION 3 INSTALLATION

3.4.1 SINGLE PHASE OUTPUT (cont.)

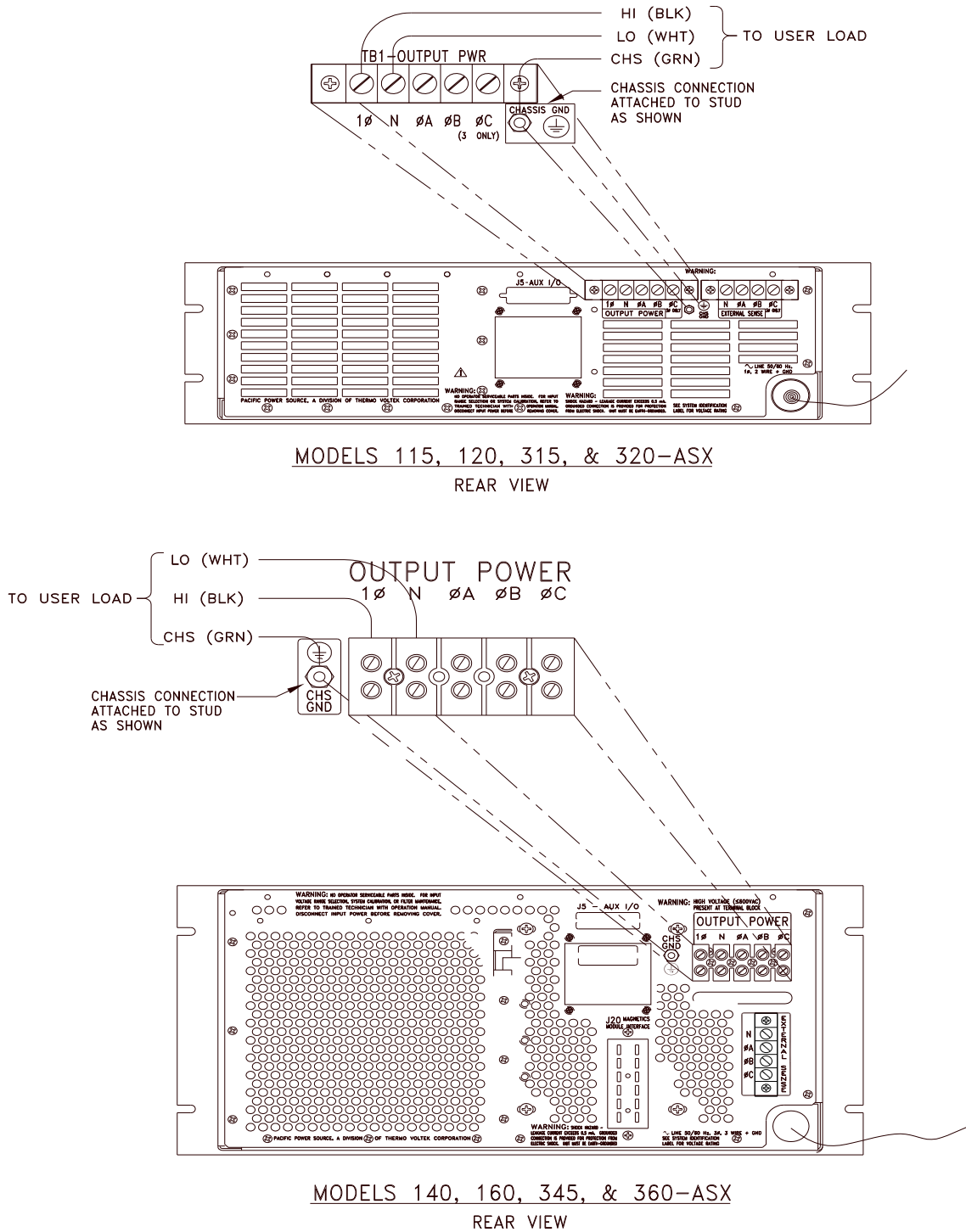
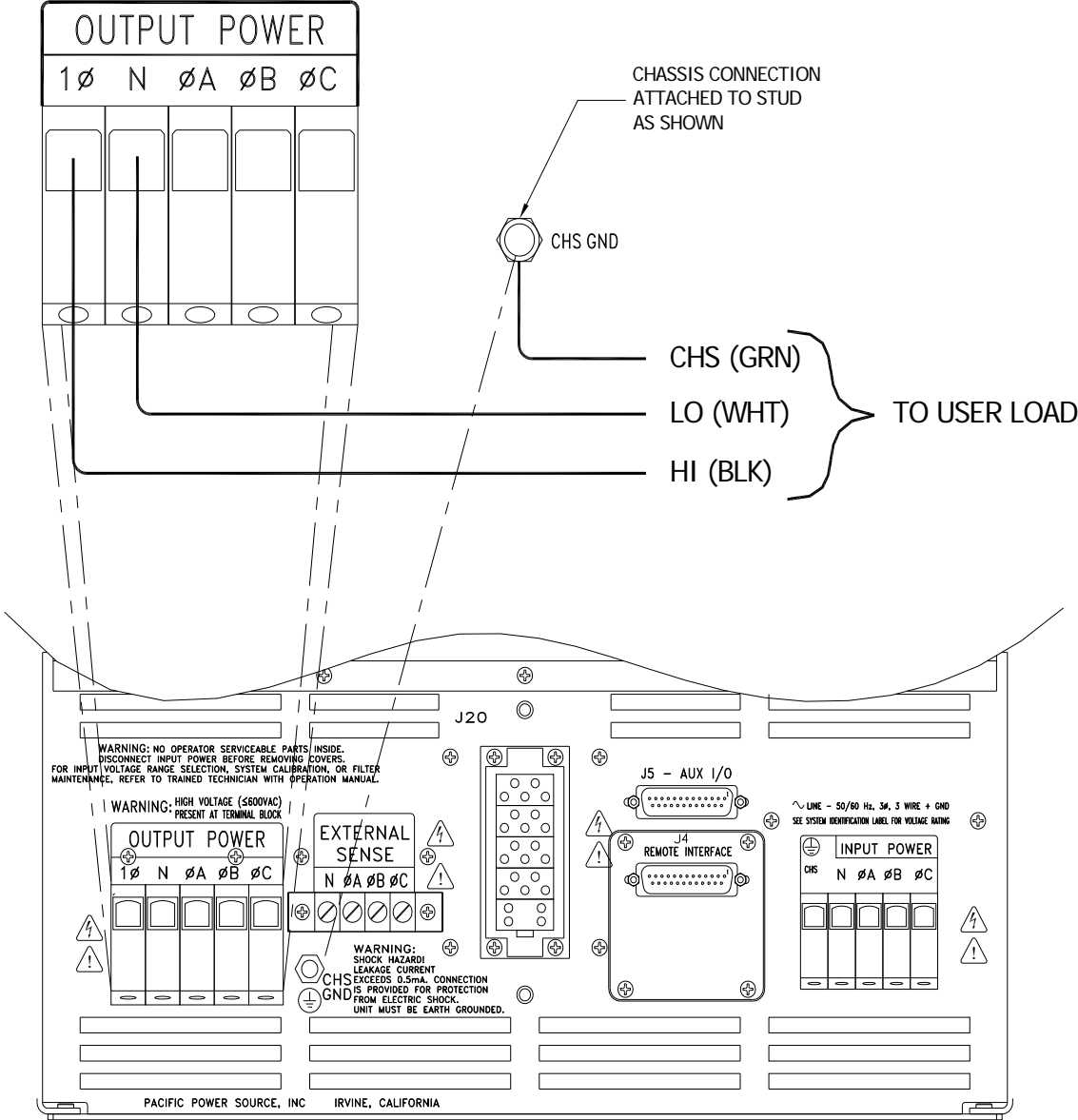

FIGURE 3.4.1.1 MODELS 115,120,140,160,315,320,345 & 360-ASX SINGLE PHASE OUTPUT CONNECTION

3.4.1 SINGLE PHASE OUTPUT (cont.)



REAR VIEW

FIGURE 3.4.1.2 3120-ASX SINGLE PHASE OUTPUT CONNECTION

3.4.2 SPLIT PHASE OUTPUT



WARNING

LETHAL VOLTAGES ARE PRESENT AT THE OUTPUT TERMINALS OF THIS MACHINE !

REFER OUTPUT CONNECTION TO A QUALIFIED ELECTRICIAN.

To operate an ASX-Series power source with split phase output, set the controller for FORM2. The wiring requirements for 1 ϕ , direct-coupled or split phase loads are shown in Figures 3.4.2.1 and 3.4.2.2. Split Phase or 2 Phase operation is defined to be two voltage vectors (V_a and V_b) which are equal in magnitude and separated by 180°. The output power is taken from the terminal block located on the rear panel of the chassis labeled "OUTPUT POWER".

This power form has a direct-coupled voltage range of 0-264 VAC_{L-I} (Models 160-ASX, 315-ASX and 360-ASX), 0-270 VAC_{L-I} (Models 140-ASX, 345-ASX, & 3120-ASX), or 0-300 VAC_{L-I} (Models 120-ASX and 320-ASX) and is well-suited for driving 220 VAC single phase loads. In this case, the high side of the load is connected to the " ϕA " terminal and the low side of the load to the " ϕB " terminal. The "N" terminal is not used with this type of load.

Some loads require three connections (V_a -N- V_b or L_1 -N- L_2). This type of load is commonly referred to as the "Split Phase" type. In this case, the "N" terminal of the output terminal block is used in addition to the wiring described above. Refer to Figures 3.4.2.1 and 3.4.2.2 for connection details.

The "CHS" terminal must always be connected to the chassis of the load. Since the output is isolated, any output terminal (direct-coupled output only) may be connected to chassis. This allows the user to re-establish a local ground for the output. The output (preferably Neutral) must be referenced to chassis somewhere. Unless demanded by a particular application, Pacific Power Source recommends that a jumper be installed across the "N" and "CHS" terminals of the Output Terminal block.

The "N" terminal of the Output Power Terminal Block must always be connected to the "CHS" terminal when using transformer-coupled outputs. Refer to Paragraph 3.4.4 for special considerations when using transformer-coupled output forms.

Refer to Paragraph 3.8 for connection of the External Sense Input, when used.

NOTE: It is the user's responsibility to meet all local and national electrical codes when installing this equipment.

3.4.2 SPLIT PHASE OUTPUT (cont.)

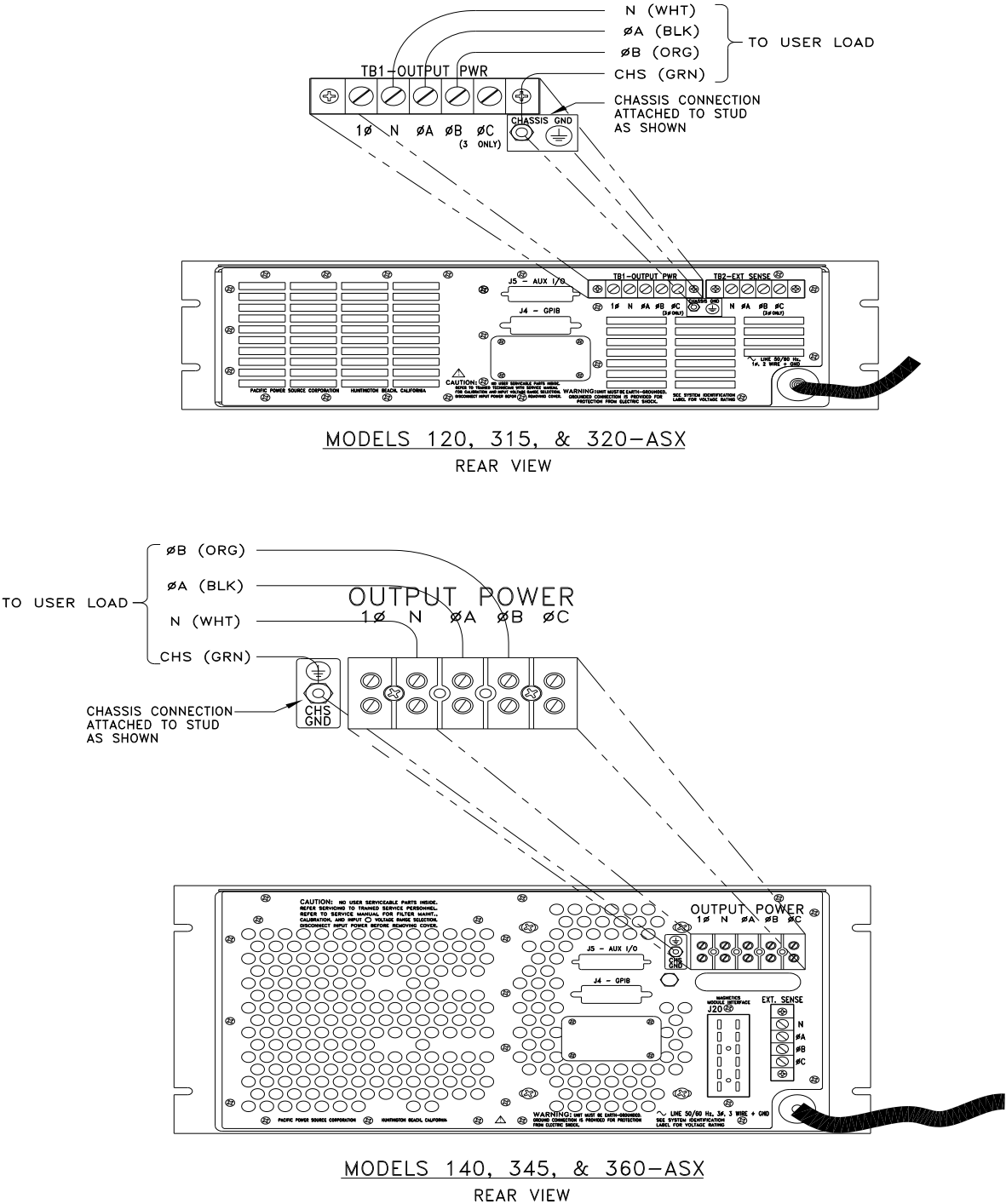

FIGURE 3.4.2.1 SPLIT PHASE OUTPUT CONNECTION

SECTION 3 INSTALLATION

3.4.2 SPLIT PHASE OUTPUT (cont.)

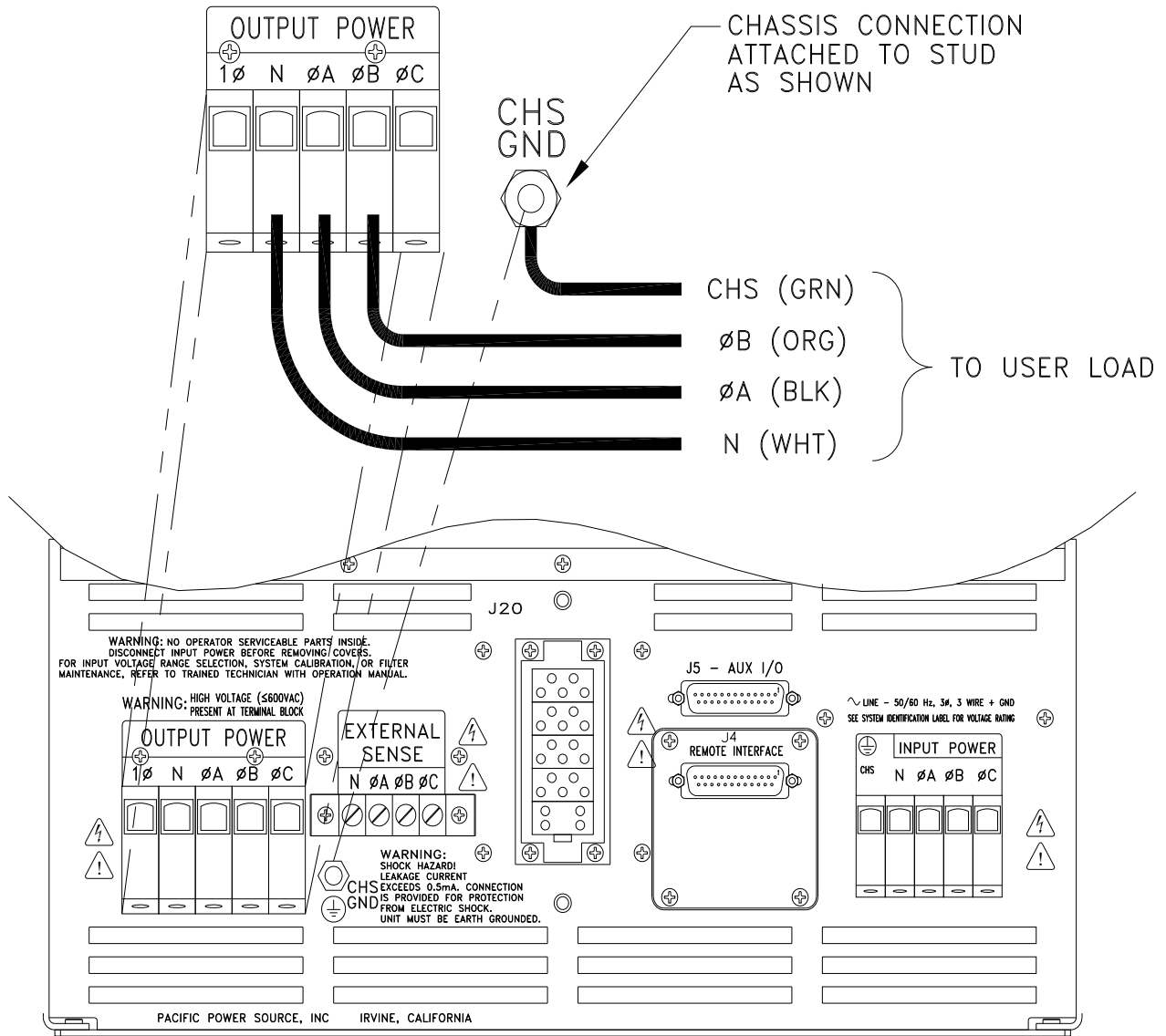

FIGURE 3.4.2.2 SPLIT PHASE OUTPUT CONNECTION

3.4.3 THREE PHASE OUTPUT



WARNING

LETHAL VOLTAGES ARE PRESENT AT THE OUTPUT TERMINALS OF THIS MACHINE!

REFER OUTPUT CONNECTION TO A QUALIFIED ELECTRICIAN.

To operate an ASX-Series power source with three phase output, set the controller for FORM3. Figures 3.4.3.1 and 3.4.3.2 show a three phase load connected to the output of an ASX-Series 3 ϕ Power Source

The output power is taken from the terminal block located on the rear panel of the chassis labeled "OUTPUT POWER". This Output Form is set for 3 PHASE when these types of load are connected.

This power form has a direct-coupled voltage range of 0-132 VAC_{L-n} (Models 315-ASX and 360-ASX), 0-135 VAC_{L-n} (Models 345-ASX and 3120-ASX), or 0-150 VAC_{L-n} (Model 320-ASX). WYE loads are connected to " ϕ A," " ϕ B," " ϕ C," and "N" terminals as shown in Figures 3.4.3.1 and 3.4.3.2. In the case of DELTA loads, the "N" terminal is not used.

The "CHS" terminal must always be connected to the chassis of the load. Since the output is isolated, any output terminal (direct-coupled output only) may be connected to chassis. This allows the user to re-establish a local ground for the output. The output (preferably Neutral) must be referenced to chassis somewhere. Unless demanded by a particular application, Pacific Power Source recommends that a jumper be installed across the "N" and "CHS" terminals of the Output Terminal block.

The "N" terminal of the Output Power Terminal Block must always be connected to the "CHS" terminal when using transformer-coupled outputs. Refer to Paragraph 3.4.4 for special considerations when using transformer-coupled output forms.

Refer to Paragraph 3.8 for connection of the External Sense Input, when used.

NOTE: It is the user's responsibility to meet all local and national electrical codes when installing this equipment.

SECTION 3 INSTALLATION

3.4.3 THREE PHASE OUTPUT (cont.)

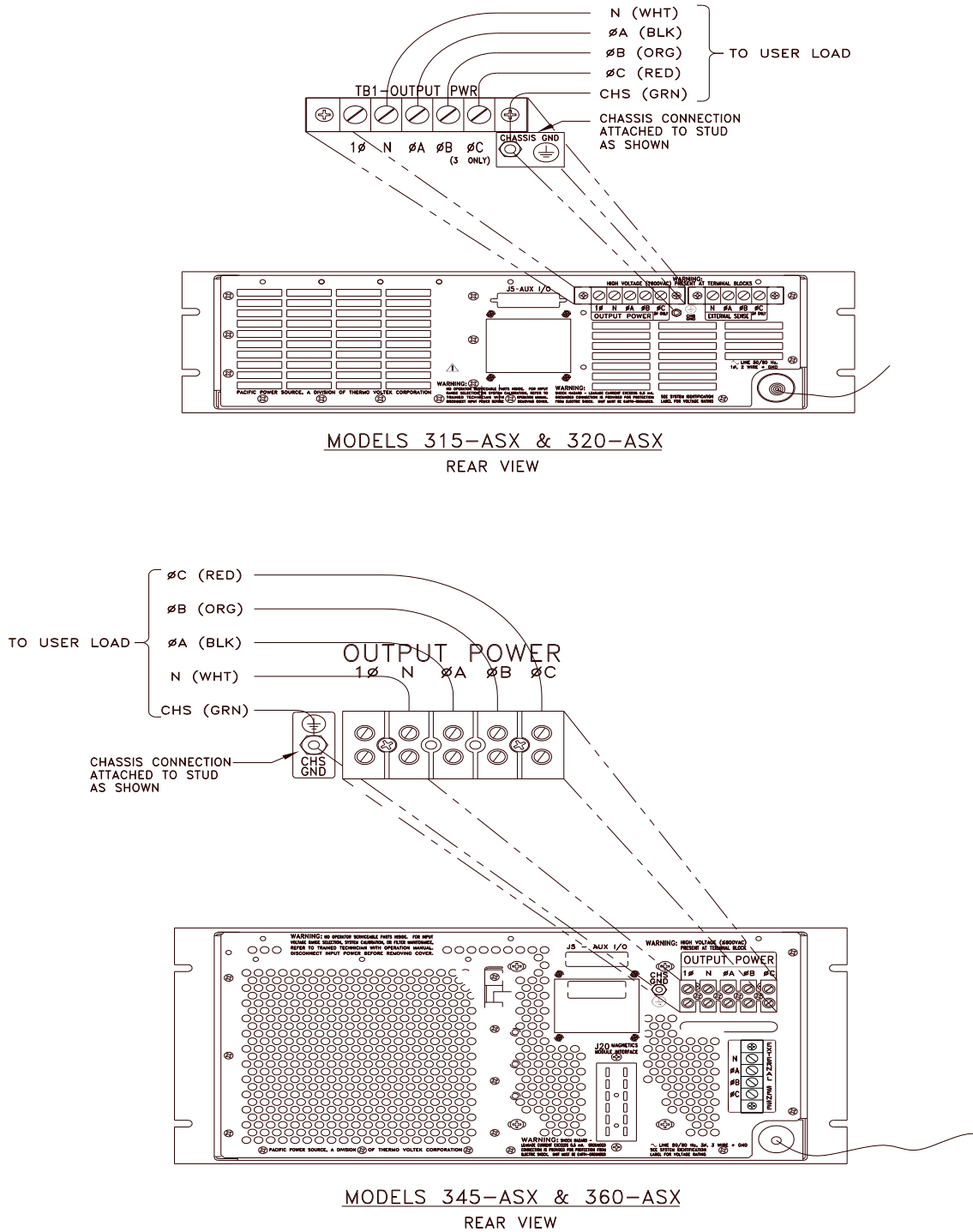

FIGURE 3.4.3.1 THREE PHASE OUTPUT CONNECTION

3.4.3 THREE PHASE OUTPUT (cont.)

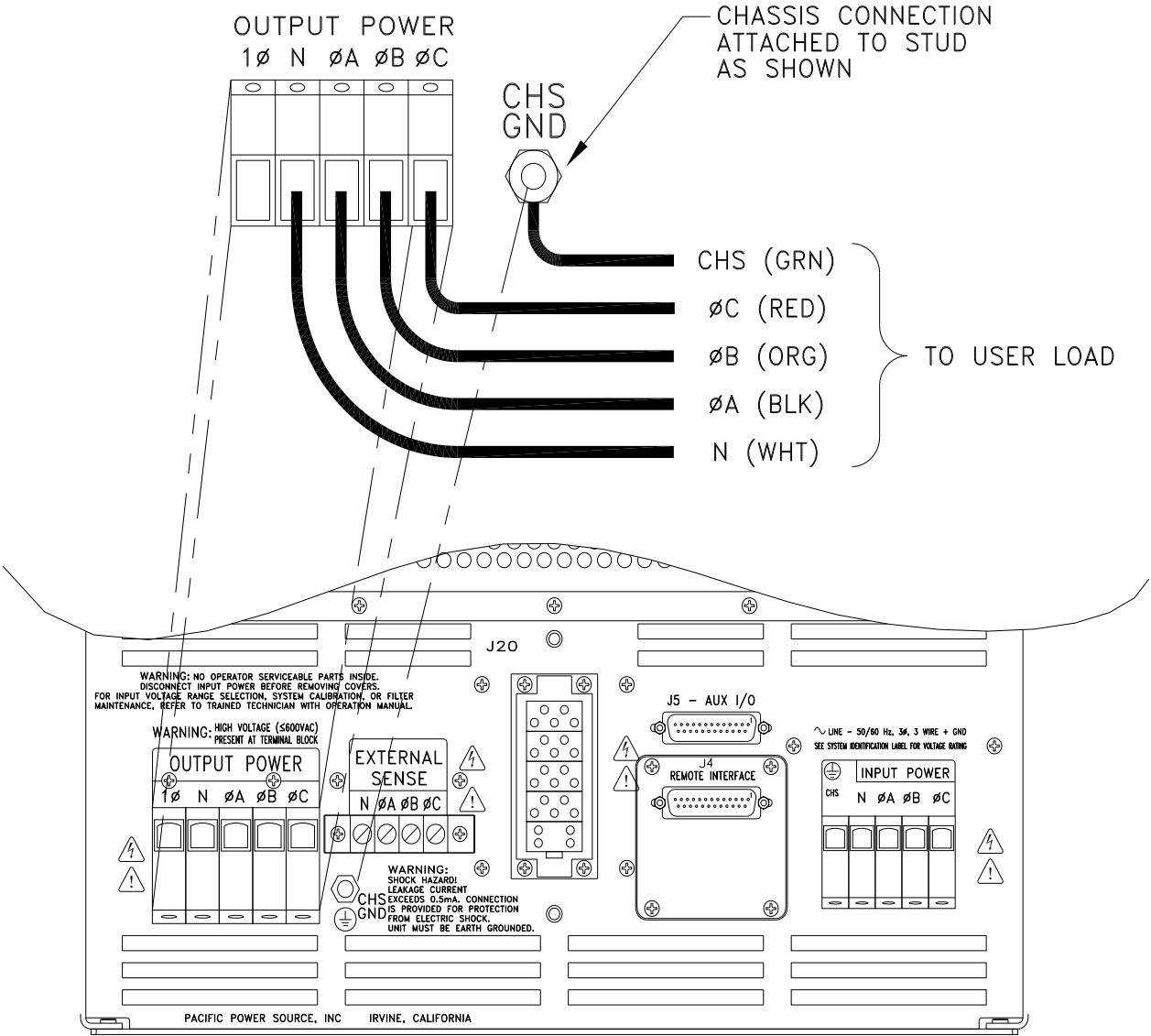

FIGURE 3.4.3.2 THREE PHASE OUTPUT CONNECTION

3.4.4 TRANSFORMER OUTPUTS - SPECIAL CONSIDERATIONS

OUTPUT GROUNDING

The output of the ASX-Series Power Source is electrically isolated from the input power and earth ground. This allows the user to establish a local ground for the output of the Power Source. The ASX-Series Power Source is designed to withstand voltage potentials of 150 VAC across the Neutral output terminal and chassis ground.

For safe operation, a ground reference should be established from output to chassis. When using the direct-coupled outputs, any leg or neutral may be connected to chassis. This is because the line to neutral voltage cannot exceed 150 VAC. Hence, the voltage stress from neutral to chassis never exceeds designed limits.

In the case of transformer-coupled outputs, neutral must be connected to chassis gnd (either locally or remotely). This is due to the fact that line to neutral voltages can be greater than 150 VAC. If a phase voltage (V_a , V_b , or V_c) were connected to chassis, the voltage would exceed the 150 VAC limit specified for the neutral to chassis voltage. Neutral must remain within 150 VAC of chassis (earth ground) at all times.

LOW FREQUENCY OPERATION

ASX-Series output transformers are designed to operate from 45 to 5,000 Hz. In the case of steady-state sine wave output, operation at frequencies as low as 30 Hz ($125 \text{ VAC } V_{pri}$) is possible.

Systems with transformers connected to the output require special attention when designing transient profiles (applicable to systems w/UPC). It is possible to design transients in which the DC Component of the periodic waveform is not zero. Attempting to push DC voltage through the transformer will cause saturation of the device. However, the output transformers are designed to support a single event, half-cycle dropout at 125 VAC_{pri} , 50 Hz without saturating. Continuous operation with an asymmetrical (DC component $\neq 0$) will cause saturation.

Operation at lower frequencies may cause saturation of the output transformers. Lower frequency operation is possible, but only at reduced output voltages.

3.5 CONNECTION OF SYSTEM CONTROL UNIT (SCU)

This paragraph describes the connection of the System Control Unit (SCU) to an ASX-Series Power Source.

Figure 3.5.1 shows the SCU connected to the Model 360-ASX Power Source. (Other models are connected similarly.) In this configuration, the controller is removed from the power source chassis and replaced with patch cables which route signals to the rear panel. Two shielded 30-conductor (15 twisted pairs) cable assemblies are used to connect the SCU to the power source. The cables are wired one-to-one and outfitted with DB-25P connectors on both ends. Hence, they cannot be installed backwards. This interface is designed to operate with cable lengths up to 50 feet. Cables, ten feet in length, are stocked by Pacific Power Source as P/N 134121. Contact Customer Service for cables of lengths other than ten feet. Refer to the UPC-Series Operation Manual for details regarding the SCU.

Note that in this configuration, Remote Interface (GPIB or RS-232) and AUX I/O connections are made at the SCU.

UPC INSTALLATION

The ASX-Series controller is modular in nature. This is a design feature which allows the user to tailor the control characteristics of the system. While it is possible to change controllers in the field, Pacific Power Source (PPS) recommends that the unit be returned to the factory when controller exchange is desired. This insures proper installation and calibration of the system by PPS technicians.

The installation of the UPC is described in the UPC-Series Operation Manual. The procedure is stated for installation into the System Control Unit (SCU). Installation of the UPC into the power source chassis proceeds in a similar manner. The primary difference between the various units is the routing of the ribbon cables to the rear panel. Be sure to note the routing of these cables before removing the existing controller; install the ribbon cables of the new UPC using the same routing. After the new UPC is in place and connected, calibration is required. Refer to Section 6 of this manual.

SECTION 3 INSTALLATION

3.5 CONNECTION OF SYSTEM CONTROL UNIT (SCU) (cont.)

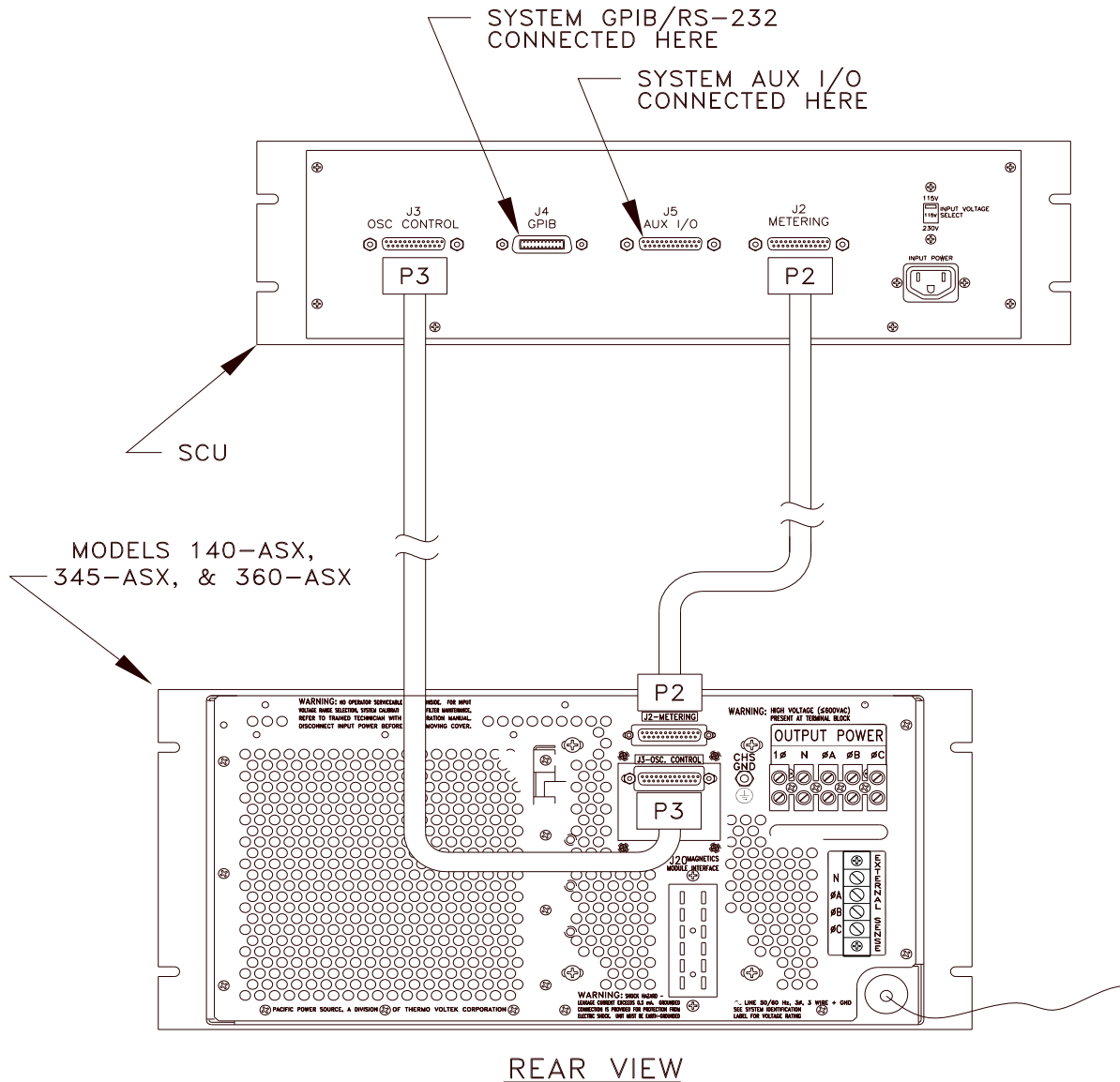

FIGURE 3.5.1 SCU CONNECTION

3.6 REMOTE INTERFACE

The UPC-Series programmable controller is supplied with one of two remote interfaces. These are the GPIB (General Purpose Interface Bus) or RS-232 Interface. Connection information relative to these interfaces is described in detail in the UPC-Series Operation manual.

On systems outfitted with the SCU, all remote interface connections and configuration settings are made at the SCU.

3.7 AUX I/O INSTALLATION

This paragraph describes connection of the AUXiliary Input/Output signals. These signals vary between the different controllers. However the method of connection remains the same.

The AUX I/O connector contains synchronizing outputs (digital) and modulation inputs (analog). These are extremely useful in certain test applications, particularly, single event phenomena. Modulation inputs are also present on this connector. The use of any of these signals is optional and connection to these points is required only when these features are used.

The AUX I/O connector is located on the rear panel of the power source (or SCU, when present) and is labeled as such. This is a DB-25S connector. A DB-25P connector is required for connection to AUX I/O connector.

On systems outfitted with the SCU, the AUX I/O connections are made at the SCU.

All signals contained within the AUX I/O connector are low-level (less than ± 15 VDC) and are with respect to earth ground reference. Refer to the appropriate controller operation manual for complete definition of the signals present on the AUX I/O connector.

3.8 EXTERNAL SENSE CONNECTION

This paragraph describes connection of external sense leads to the ASX-Series Power Source. External Sense wire size and methods are discussed.

The ASX-Series Power Source contains External Sense Circuits. These circuits measure output voltage at a external sense point. Since this feature can be completely disabled, the wiring detailed in this paragraph is optional. If the External Sense feature is desired, this paragraph describes the wiring requirements for the function.



Figures 3.8.1 and 3.8.2 show external sense wiring for 1, 2, and 3 ϕ systems. There is little or no current flowing through the External Sense Feedback lines. Standard 22 AWG, 600 Volt control wire is recommended for this application. Twisting the External Sense wiring is recommended and, in some cases, can improve performance. In noisy environments, shielding may become necessary to improve performance. If shielded cable is used, be sure to ground the shield at one end only to prevent the possibility of creating a ground loop.

When the neutral wire is not used by the load on a split phase output (2 Phase Output Mode, refer to paragraph 3.4.2), connect the Neutral terminal of the External Sense Terminal block to the Neutral terminal of the Output Power Terminal block. In cases where the load has a neutral terminal, connect the neutral lead from External Sense Terminal block to the neutral terminal of the load.

When wiring the External Sense Leads to a DELTA load (refer to paragraph 3.4.3), connect the Neutral terminal of the External Sense Terminal block to the Neutral terminal of the Output Terminal block.

3.8 EXTERNAL SENSE CONNECTION (cont.)

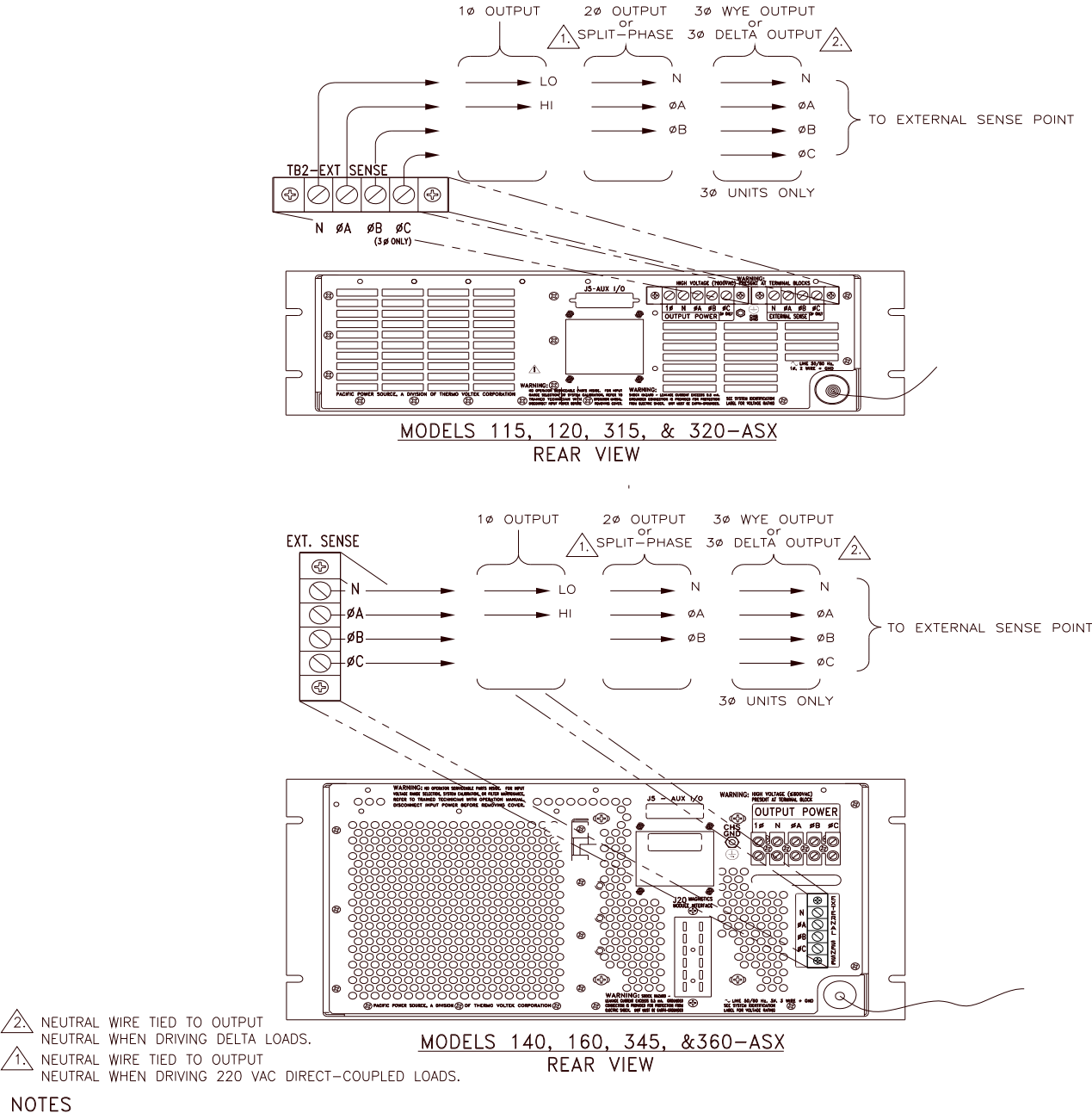

FIGURE 3.8.1 MODELS 115, 120, 140, 160, 315, 320, 345, & 360-ASX EXTERNAL SENSE CONNECTION

SECTION 3 INSTALLATION

3.8 EXTERNAL SENSE CONNECTION (cont.)

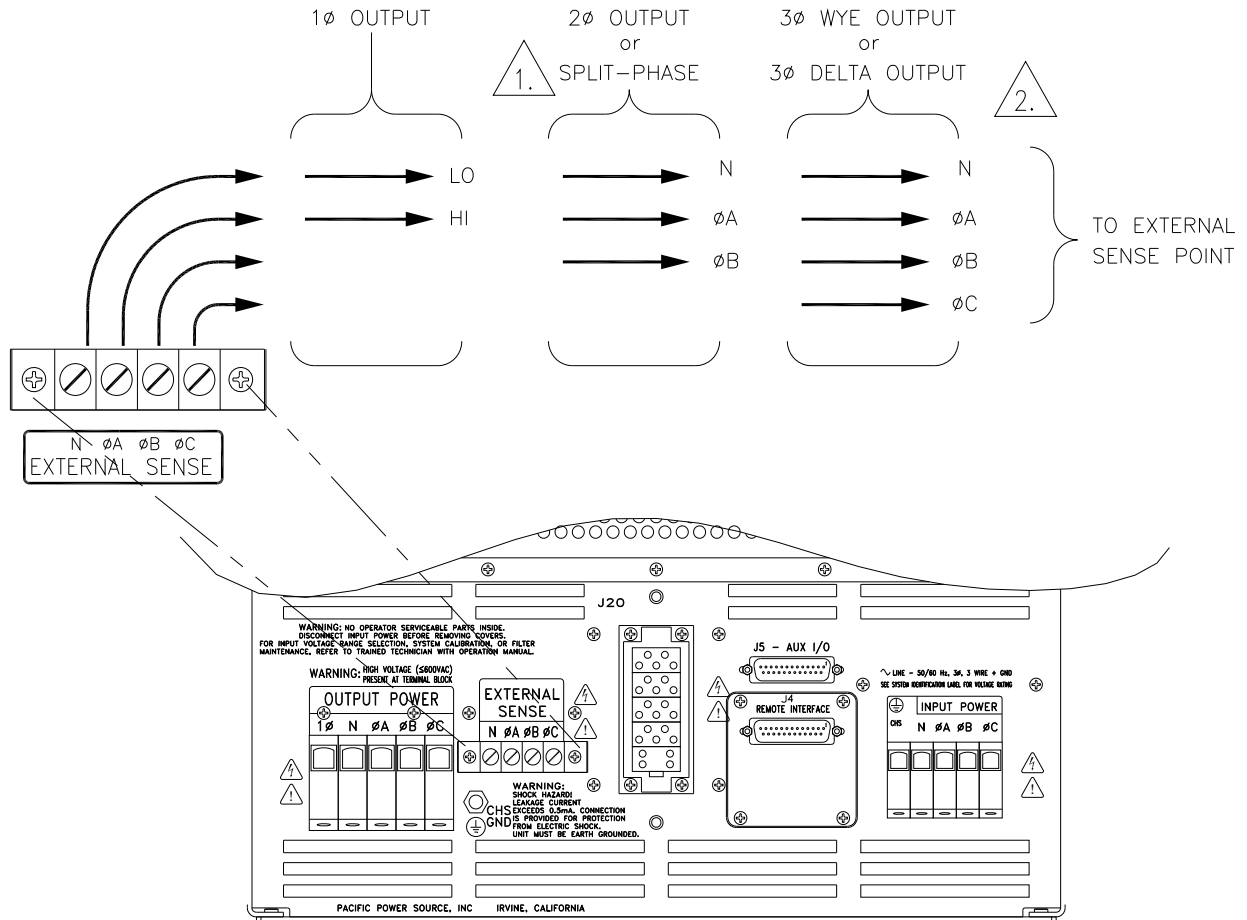

FIGURE 3.8.2 MODEL 3120-ASX EXTERNAL SENSE CONNECTION

SECTION 4

OPERATION

4 OPERATION

This section describes the operation of an ASX-Series AC Power Source. The procedure described in the following paragraphs is a general procedure common to all systems (except as noted). This procedure does not detail operation of a specific controller. Refer to the appropriate controller manual for detailed information regarding the installed controller.

4.1 FRONT PANEL CONTROLS

This paragraph shows the location of the front panel controls and indicators of the ASX-Series Power Source. A brief description of each is also given. Figure 4.1 is a front view of the Model 360-ASX with a UPC-3 controller installed. The front panel control section is similar in all ASX-Series models. Refer to the UPC-Series OPERATION MANUAL or Section 8 of this manual for information relative to the installed controller.

1. INPUT POWER SWITCH (Circuit Breaker)

Circuit Breaker used as the main input ON/OFF control and protects the power source from drawing excessive input current from the input AC line.

2. OUTPUT POWER SWITCH and INDICATORS

Switch used to control the output contactor of the ASX-Series Power Source. Indicators show the state of the output contactor. The power source will enter shutdown for the case of over-temperature or other internal fault. Shutdown is reset when the Output Power Switch is set to OFF and the fault has cleared. (Switch not present on SCU.) Refer to Paragraph 4.5 for details.

3. OUTPUT COUPLING INDICATORS

LED's which show the Output Coupling of the power source.

4. OUTPUT FORM INDICATORS

LED's which show the Output Form that is active. (The Model 115-ASX is a Single Phase output system and has no Phase indicators. The 3 Phase indicator is not present on the Models 120-ASX and 140-ASX.)

4.1 FRONT PANEL CONTROLS (cont.)

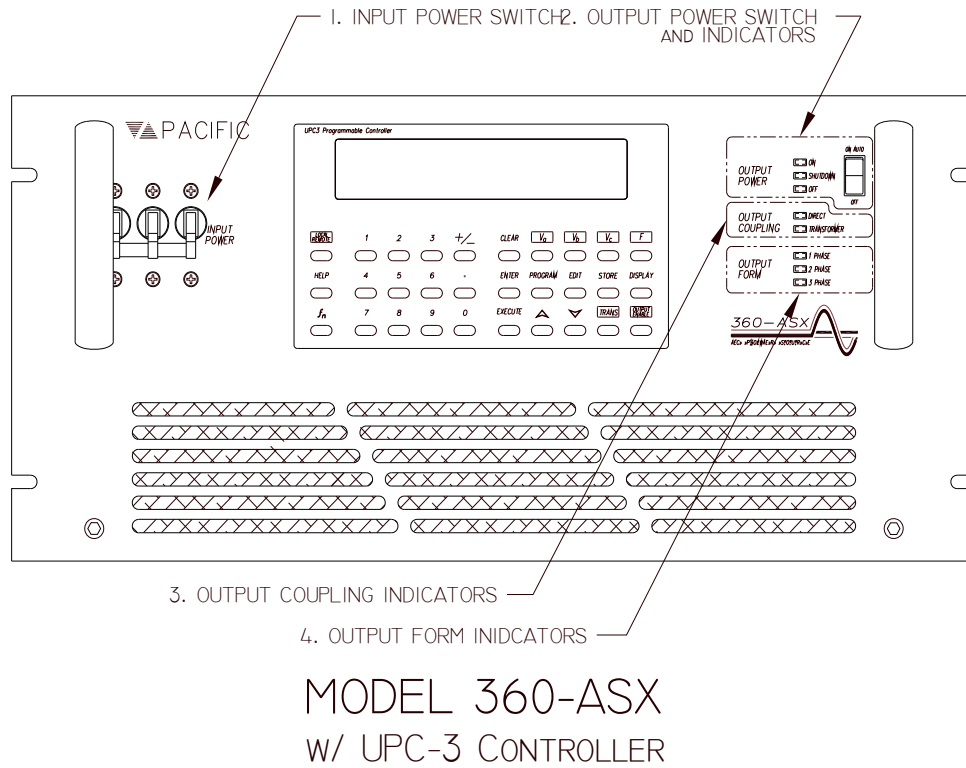

FIGURE 4.1 FRONT PANEL CONTROLS

4.2 INITIAL POWER-UP

This paragraph describes the procedure used to turn on the ASX-Series Power Source for the first time. The steps below are the recommended order of operation.



WARNING

LETHAL VOLTAGES ARE PRESENT AT THE OUTPUT TERMINALS OF THIS MACHINE!

1. For new installations, check input connections (including proper input voltage). Do not connect the load at this time. Also verify that the OUTPUT POWER switch is in the OFF position.
2. Switch the INPUT POWER switch to the ON position. The controller will light up and begin to display output data.
3. Set the controller for the desired output voltage, frequency, phase separation, etc. (Refer to the controller operation manual for details regarding adjustment of output parameters.)
4. Set the OUTPUT POWER switch of the Power Source to the ON/AUTO position and press the UPC OUTPUT ENABLE switch to set it to the ON position.



CAUTION

DO NOT CONNECT ANY LOADS TO THE OUTPUT OF THE POWER SOURCE UNTIL THE OUTPUT VOLTAGE AND FREQUENCY HAVE BEEN VERIFIED AS CORRECT.

APPLICATION OF IMPROPER VOLTAGE OR FREQUENCY CAN DAMAGE USER LOADS.

5. Verify proper voltage, frequency and waveform at the output terminal block. If the output is not that which is desired, set the output to desired values. Refer to the controller manual for details.
6. Once the desired output is verified, turn the system OFF by first setting the OUTPUT POWER SWITCH to the OFF position and then opening the INPUT POWER SWITCH. Connect the load.
7. Re-start the unit beginning at step 2, above. Verify that the system delivers power to the load.

4.3 ROUTINE POWER-UP

This paragraph describes the procedure used to turn on the ASX-Series Power Source after it has been verified that the installation is correct. The steps below are the recommended order of operation.



WARNING

LETHAL VOLTAGES ARE PRESENT AT THE OUTPUT TERMINALS OF THIS MACHINE!

1. Set the OUTPUT POWER switch to the OFF position. Switch the INPUT POWER switch to the ON position. The controller will light up and begin to display output data. The value of the output parameters will be set for the same values as when the unit was last turned off.
2. Set the OUTPUT POWER switch to the ON/AUTO position and press the UPC OUTPUT ENABLE switch to set it to the ON position.



CAUTION

DO NOT CONNECT ANY LOADS TO THE OUTPUT OF THE POWER SOURCE UNTIL THE OUTPUT VOLTAGE AND FREQUENCY HAVE BEEN VERIFIED AS CORRECT.

APPLICATION OF IMPROPER VOLTAGE OR FREQUENCY CAN DAMAGE USER LOADS.



WARNING

LETHAL VOLTAGES ARE PRESENT AT THE OUTPUT TERMINALS OF THIS MACHINE!

4.4 SYSTEM TURN-OFF

This paragraph describes the procedure used to turn off the ASX-Series Power Source.

The ASX-Series Power Source is turned off by:

1. Setting the OUTPUT POWER Switch to the OFF position.
2. Opening the INPUT POWER circuit breaker.

4.5 SYSTEM SHUTDOWN

This paragraph describes the conditions which will cause system shutdown and the procedure used to reset the ASX-Series Power Source.

4.5.1 SHUTDOWN CONDITIONS

The Output Contactor of the ASX-Series Power Source will be opened automatically when:

1. Either the Input Power Transformer or one of the power amplifier PCB's has reached an Over-temperature condition. (Over-temperature is usually caused by either blocking the air inlets--includes dirty fan filters--or overloading the power source.)
2. The state of the Output Coupling has changed while the Output Contactor is engaged.
3. The state of the Output Form has changed while the Output Contactor is engaged.

When the Output Contactor has been opened due to one of the above faults, the SHUTDOWN LED on the front panel of the power source will be lighted. The output contactor will remain open while the SHUTDOWN LED is lighted. This LED will remain lighted until reset.

If the Output Power Switch is in the ON/AUTO position when the unit is turned on, the SHUTDOWN LED will light. This is normal operation. The LED is turned off simply by placing the Output Power Switch into the OFF position.

4.5.2 RESETTING SHUTDOWN FAULTS

The shutdown fault is reset as follows:

1. Set the OUTPUT POWER Switch to the OFF position.
2. Wait for the SHUTDOWN LED to extinguish. This LED will remain lighted until the condition which caused the shutdown to occur has been corrected. In the case of shutdown due to over-temperature this may take some time. The output contactor cannot be engaged until the shutdown fault has been cleared.

NOTE: The SHUTDOWN LED is latched on when a fault occurs. The OUTPUT POWER Switch or the Output Enable of the UPC MUST be placed in the OFF position before the SHUTDOWN LED will extinguish, even if the original fault no longer exists.

3. After the SHUTDOWN LED has been extinguished, the unit will function normally.

4.6 OUTPUT VOLTAGE FORMS

This paragraph describes the various output voltage forms for which the ASX-Series Power Source can be configured.

A recommended strategy for selecting the optimum output voltage form is based two basic philosophies. The first is to use a direct-coupled output form whenever possible. The second is to select the minimum voltage range necessary to drive the load.

Direct-coupled output is preferred because the output impedance is extremely low. A second reason to use the direct-coupled output form is that low frequency limitations associated with transformer outputs do not exist. This is especially true when attempting to perform sub-cycle transients.

Selecting the minimum voltage range necessary to drive the load allows the power source to operate more efficiently. This results in less heat being dissipated into the surrounding environment.

Paragraph 4.6.1 discusses the various structures associated with the different output forms.

4.6.1 SYSTEM ARCHITECTURE

The ASX-Series Power Source output can be configured for single, split, and three phase voltage forms. Figure 4.6.1 is a simplified block diagram of the possible output architectures. Only the direct-coupled output forms are shown. All of the forms can be supplied with transformers to raise the output voltage level.

The 1 PHASE mode of operation is a one vector output form. All of the power amplifier PCB's are connected in parallel to form one output vector. The standard, direct-coupled version of this output form is capable of 0-132 VAC_{L-n} (Models 115, 160, 315, and 360-ASX), 0-135 VAC_{L-n} (Models 140, 345, and 3120-ASX), or 0-150 VAC_{L-n} (Models 120-ASX and 320-ASX). The voltage ranges of the various transformer output forms are: VR1.5 - 0 to 198 V_{L-n} (Models 115, 160, 315, and 360-ASX) or 0 to 203 V_{L-n} (Models 140, 345, and 3120-ASX), VR2.0 - 0 to 264 V_{L-n} (Models 115, 160, 315, and 360-ASX) or 0 to 270 V_{L-n} (Models 140, 345, and 3120-ASX), and VR2.5 - 0 to 330 V_{L-n} (Models 115, 160, 315, and 360-ASX) or 0 to 338 V_{L-n} (Models 140, 345, and 3120-ASX).

The 2 PHASE mode of operation is a two vector output form where the vectors are separated by 180° and equal in amplitude. This output form uses power amplifiers in pairs, one for each vector. The load can be attached from either line to neutral, line to line or a combination of both. The standard, direct-coupled version of this output form has a voltage range of 0-264 VAC_{L-L} (Models 160-ASX, 315-ASX and 360-ASX), 0-270 VAC_{L-L} (Models 140, 345, and 3120-ASX), or 0-300 VAC_{L-L} (Models 120-ASX and 320-ASX). The voltage ranges of the various transformer output forms are: VR1.5 - 0 to 396 V_{L-L} (Models 160-ASX, 315-ASX and 360-ASX) or 0 to 405 V_{L-L} (Models 140, 345, and 3120-ASX), VR2.0 - 0 to 528 V_{L-L} (Models 160-ASX, 315-ASX and 360-ASX) or 0 to 540 V_{L-L} (Models 140, 345, and 3120-ASX), and VR2.5 - 0 to 600 V_{L-L} (Models 140, 160, 315, 345, 360, and 3120-ASX). Note that in the case of the Models 315, 320, 345 and 360-ASX, only two of the three power amplifiers are connected limiting these systems to producing only two-thirds of rated output power in this configuration.

NOTE: The ASX-Series Power Sources do not support voltages in excess of 600 VAC_{rms} due to controller, safety, and spacing limitations. Attempting to defeat the inherent programming limitations of the controller to obtain higher voltages is strongly recommended against.

The 3 PHASE mode of operation is a three vector output form with vectors normally separated by 120°. Power amplifiers are supplied in groups of three with this output form and are WYE connected. A WYE load is connected across the A, B, C, and Neutral terminals of the output terminal block. This output form will also drive DELTA loads. DELTA loads are simply connected across the A, B, and C terminals of the output terminal block with the Neutral terminal not connected. The standard, direct-coupled version of this form has an output voltage range of 0 to 132/229 VAC (Models 315-ASX and 360-ASX), 0 to 135/234 VAC (Models 345-ASX and 3120-ASX), or 0 to 150/260 VAC (Model 320-ASX). The voltage ranges of the various transformer output forms are: VR1.5 - 0 to 198/343 VAC (Models 315-ASX and 360-ASX) or 0 to 203/352 VAC (Models 345-ASX and 3120-ASX), VR2.0 - 0 to 264/457 VAC (Models 315-ASX and 360-ASX) or 0 to 270/468 VAC (Models 345-ASX and 3120-ASX), and VR2.5 - 0 to 330/572 VAC (Models 315-ASX and 360-ASX) or 0 to 338/585 VAC (Models 345-ASX and 3120-ASX).

4.6.1 SYSTEM ARCHITECTURE (cont.)

The three phase output systems can be used as 1 or 2 phase systems. This is accomplished by setting the controller for the appropriate output form and then connecting the load accordingly. Systems which contain a UPC-Series programmable controller have the ability to change output form via commands.

It should be noted that most ASX-Series Power Sources may be configured with transformer outputs, and are therefore dual-range. Selection of the appropriate output range, direct or transformer-coupled, is via commands issued by the controller.

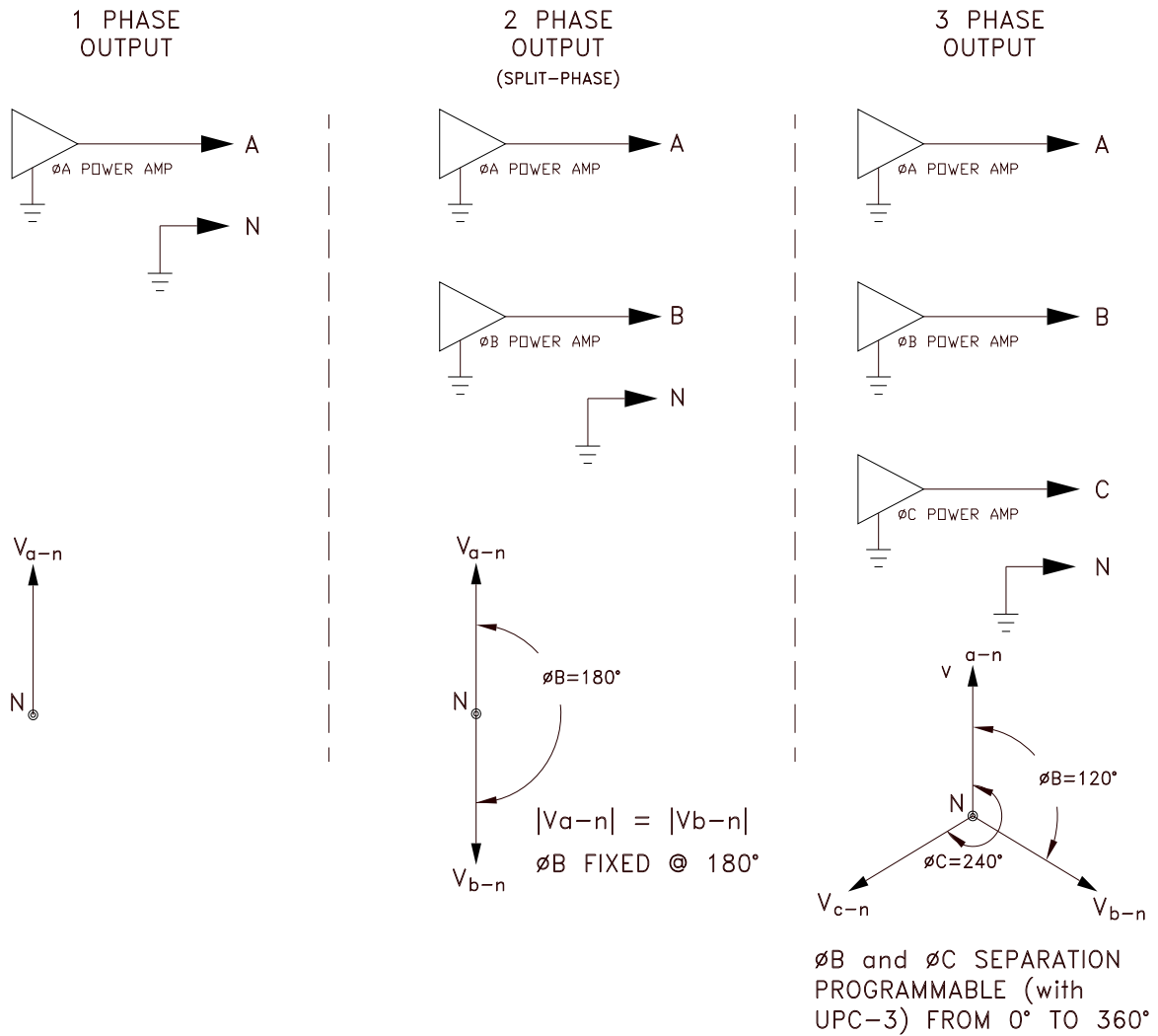

FIGURE 4.6.1 ASX-SERIES SYSTEM ARCHITECTURE

SECTION 5

MAINTENANCE

5 MAINTENANCE

This section describes the maintenance of the ASX-Series AC Power Source.

5.1 MAINTENANCE INTERVAL

Maintenance of the Models 115-ASX, 120-ASX, 315-ASX, and 320-ASX Power Sources is required once every six months and consists of performing regular calibration.

Maintenance of the Models 140-ASX, 160-ASX, 345-ASX, 360-ASX, and 3120-ASX Power Sources is required once every three months and consists of checking/cleaning the fan filter, with regular calibration once every six months.

5.2 MAINTENANCE REQUIREMENTS

5.2.1 MODELS 115, 120, 315, AND 320-ASX

The Models 115-ASX, 120-ASX, 315-ASX, and 320-ASX require calibration once every six months as regular maintenance. Refer to Section 6 for details.

5.2.2 MODELS 140, 160, 345, 360, AND 3120-ASX

The Models 140, 160, 345, 360, and 3120-ASX require calibration once every six months and maintenance once every three months. Maintenance of these models consists of verifying that the fan filter is clean. It is important that this filter is kept clean in order to insure proper cooling of internal components.

The fan filter is cleaned as follows:

1. Slide the chassis forward to reveal the fan filter access panel, located on the bottom of the chassis.
2. Loosen the 2 screws that partially protrude from the side panels, directly above the filter, to allow the filter to slide out of its holder. (For model 3120-ASX, remove the fan filter access panel.)
3. The filter will slide out of its holder. Remove the filter.
4. Wash and dry the fan filter. The filter is a metal screen mesh type. It is reusable and is best cleaned by washing with warm soapy water. Make sure that the filter is dry before installing it into the chassis.
5. Install the filter and re-tighten the screws loosened in step 2. (for Model 3120-ASX, install the filter and then replace the fan filter access plate)
6. Slide the chassis back into its normal position.

If system operation is suspect or the calibration interval has passed, perform the calibration procedure outlined in Section 6.

SECTION 6

CALIBRATION

6 CALIBRATION

This section describes the calibration of the ASX-Series AC Power Source.

6.1 CALIBRATION INTERVAL

The ASX-Series Power Source requires calibration once every six months or after service has been performed to the system.

6.2 TEST EQUIPMENT REQUIREMENTS



The test equipment listed below is required for calibration of the ASX-Series Power Source.

1. Digital Voltmeter: 4½ Digit True-RMS responding 5000 Hz bandwidth, min.
2. Frequency counter: 5 digit counter, min.
3. Digital Ammeter: 3½ Digit True-RMS responding 5000 Hz bandwidth, min.
(Alternate Approach: Current transformer used in conjunction with the DVM.)
4. Oscilloscope: (Optional)
5. Load (Resistive): Varies by model number

<u>Current requirement</u>	<u>@ Voltage</u>	<u>Model Name</u>
10A/1φ	@ 132 VAC _{l-n}	Model 115-ASX
10A/1φ 5A/φ - 2φ	@ 150 VAC _{l-n}	Model 120-ASX
26A/1φ 13A/φ - 2φ	@ 135 VAC _{l-n}	Model 140-ASX
40A/1φ 13.3A/φ - 2φ	@ 132 VAC _{l-n}	Model 160-ASX
10A/1φ 3.3A/φ - 3φ	@ 132 VAC _{l-n}	Model 315-ASX
10A/1φ 3.3A/φ - 3φ	@ 150 VAC _{l-n}	Model 320-ASX
30A/1φ 10A/φ - 3φ	@ 135 VAC _{l-n}	Model 345-ASX
40A/1φ 13.3A/φ - 3φ	@ 132 VAC _{l-n}	Model 360-ASX
80A/1φ 26A/φ 3φ	@ 135 VAC _{l-n}	Model 3120-ASX

6.3 CALIBRATION PROCEDURE

The calibration procedure which follows verifies that system gains are set properly and that the system performance, relative to output power capability is intact. Gains in various signal paths within the controller are adjusted by the procedure of Paragraph 6.3.1. Output power capability of the power source is tested by the procedure of Paragraph 6.3.2.

	 WARNING
<p>THIS EQUIPMENT CONTAINS HIGH ENERGY, LOW IMPEDANCE CIRCUITS!! LETHAL POTENTIALS ARE CONTAINED WITHIN THE CABINET.</p> <p>CARE MUST BE EXERCISED WHEN SERVICING THIS EQUIPMENT IN ORDER TO PREVENT SERIOUS OPERATOR INJURY OR EQUIPMENT DAMAGE.</p> <p>VOLTAGE AT THE TERMINALS RESPONDS INSTANTLY WHEN THE OUTPUT IS ACTIVATED.</p> <p>OBSERVE THE FOLLOWING WHEN SERVICE, MAINTENANCE, OR CALIBRATION ARE REQUIRED:</p> <ol style="list-style-type: none"> 1) REMOVE ALL JEWELRY FROM HANDS, ARMS AND NECK WHEN SERVICING THIS EQUIPMENT. THIS PREVENTS THE POSSIBILITY OF SHORTING THROUGH THE JEWELRY AND CAUSING BURNS OR ELECTROCUTION OF THE OPERATOR. 2) WEAR SAFETY GLASSES WHEN SERVICING THIS EQUIPMENT TO PREVENT EYE INJURY DUE TO FLYING PARTICLES CAUSED BY ACCIDENTAL SHORT CIRCUIT CONDITIONS. 3) DO NOT REMOVE ANY PANEL OR COVER WITHOUT FIRST REMOVING THE INPUT SERVICE BY OPENING ALL CIRCUIT BREAKERS. 4) SERVICE OTHER THAN EXTERNAL CLEANING SHOULD BE REFERRED TO PERSONNEL AUTHORIZED BY THE FACTORY TO SERVICE THIS EQUIPMENT. 	

6.3.1 CALIBRATE CONTROLLER

The first step in system calibration is to calibrate the controller. The controller calibration procedure is unique to the installed controller. Calibrate the controller as stated in the controller manual.

UPC Controller - Refer to Section 8 of the UPC-Series Operation Manual.

6.3.2 POWER SOURCE LOAD TEST

This paragraph describes the test to be used to verify that the power source is able to deliver rated load. Additionally, the output metering function of the controller is also checked.

The test proceeds in the manner below.

1. Set the Power Source for 3 ϕ Output (1 ϕ for the Model 115-ASX, 2 ϕ for Models 120-ASX and 140-ASX), Direct-coupled, CSC Enabled.
2. Attach a full-rated load to the ϕ A Output Terminal (1 ϕ Output Terminal for the Model 115-ASX). (Refer to the list in paragraph 6.2 for the proper load.)
3. Set the output for full-rated voltage and close the Output Contactor.
4. Verify that the output voltage remains constant (within load regulation limits) and that the Output metering reads correct values.
5. Open the Output Contactor.
6. Repeat for ϕ B and ϕ C (ϕ B for 2 ϕ and 3 ϕ systems only, ϕ C for 3 ϕ systems only) outputs.
7. Configure for 1 ϕ Output and repeat above procedure.
8. If the system is outfitted with transformer outputs, set the Power Source for 3 ϕ Output (1 ϕ for the Model 115-ASX, 2 ϕ for Models 120-ASX and 140-ASX), Transformer-coupled, CSC Enabled.
9. Verify that the output voltage and Power Source meters read properly.

SECTION 7

SERVICE

7 SERVICE

This section describes service of the ASX-Series AC Power Source.

7.1 SERVICE PROCEDURE

The ASX-Series Power Source contains no user serviceable parts. Service is accomplished by returning the unit to the factory or authorized service center. Under some circumstances, the factory may authorize the user to perform limited sub-assembly or component changes as deemed allowable by the factory service representative. For this purpose, many sub-assembly and component level Pacific Power Source Corporation part numbers have been included here. Part numbers for various components are listed separately for each Model.

When questions regarding operation arise or service is required, call the factory for instructions. Pacific Power Source Corporation maintains a staff of highly trained technicians who are ready to assist. The phone number to call is (714)898-2691.

7.2 ROSTER OF SYSTEM LEVEL FACTORY PART NUMBERS

The following is a list of system level factory part numbers for the models which comprise the ASX-Series line of equipment. Part numbers are stated for reference.

<u>MODEL NAME</u>		<u>PART No.</u>
MODEL 115-ASX	1.5 kVA AC Power Source	143139
MODEL 120-ASX	2.0 kVA AC Power Source	143148
MODEL 140-ASX	4.0 kVA AC Power Source	143013
MODEL 160-ASX	6.0 kVA AC Power Source	143014
MODEL 315-ASX	1.5 kVA AC Power Source	143145
MODEL 320-ASX	2.0 kVA AC Power Source	143149
MODEL 345-ASX	4.5 kVA AC Power Source	143016
MODEL 360-ASX	6.0 kVA AC Power Source	143017
MODEL 3120-ASX	12.0 kVA AC Power Source	143008
Transformer assembly for the 115-ASX		140140
Magnetics Module for the 140, 345, and 360-ASX		134350
Magnetics Module for the 3120-ASX		140640
System Control Unit (SCU)		133000
UPC 1 Programmable 1 ϕ Controller		141102
UPC 3 Programmable 3 ϕ Controller		141302

7.3 SUB-ASSEMBLY AND CHASSIS COMPONENT PART NUMBERS

The factory part numbers given in the following sections are provided to aid the user in obtaining spare or repair sub-assemblies and components where the factory has given permission, in advance, for the user to perform field repairs on the ASX-Series Power Source.

7.3.1 FACTORY PART NUMBERS, MODEL 115-ASX (PART NUMBER 143139)

<u>SUB-ASSEMBLY</u>	<u>FACTORY PART No.</u>
LED Display PCB:	139071
Power Amplifier PCB:	140070
Output Filter PCB:	140071
Control/Logic PCB:	140072
High Voltage Power Supply PCB:	140077
Input Filter PCB	140079
<u>CHASSIS COMPONENT</u>	<u>FACTORY PART No.</u>
Input Circuit Breaker:	716070 or 716075 for CE units
Front Panel Handle:	702112
Output Terminal Block:	705077
External Sense Terminal Block:	705076
Input Power Cord Strain Relief:	779009
Input Transformer:	531317
Power Amplifier Fan:	703145
Input Transformer Fan:	703145

7.3.2 FACTORY PART NUMBERS, MODEL 120-ASX (PART NUMBER 143148)

<u>SUB-ASSEMBLY</u>	<u>FACTORY PART No.</u>
LED Display PCB:	139071
Low Voltage Power Supply/Fan Speed Cont. PCB:	139074
Power Factor Correction PCB:	139075
Control/Logic PCB:	139078
Power Amplifier PCB:	140070
Output Filter PCB	140074
Input Filter PCB	140079
<u>CHASSIS COMPONENT</u>	<u>FACTORY PART No.</u>
Input Circuit Breaker:	716070 or 716075 for CE units
Front Panel Handle:	702112
Output Terminal Block:	705077
External Sense Terminal Block:	705076
Input Power Cord Strain Relief:	779009
Input Transformer (T1):	531318
Low Voltage Input Transformer (T2):	531290
Output Relay:	717040
Power Amplifier Fan:	703145
Input Transformer Fan:	703136

7.3.3 FACTORY PART NUMBERS, MODEL 140-ASX (PART NUMBER 143013)

<u>SUB-ASSEMBLY</u>	<u>FACTORY PART No.</u>
LED Display PCB:	139071
Control/Logic PCB:	139078
Auxiliary PCB:	140073
Low Voltage Power Supply/Fan Speed Cont. PCB:	139074
Power Amplifier PCB:	140070
<u>CHASSIS COMPONENT</u>	<u>FACTORY PART No.</u>
Input Circuit Breaker:	716077 or 716071 for CE units
Front Panel Handle:	702112
Trunk Handle:	702130
Output Terminal Block:	705080
External Sense Terminal Block:	705076
Magnetics Module Bypass-Conn. Housing (J20):	714068
Panel-Mount Magnetics Module Connector (P20):	714185
Input Power Cord Strain Relief:	779009
Input Transformer:	531302
Input Power Supply Bridge Rectifier:	743011
Input Power Supply High Voltage DC Capacitor:	720588-41
Output Contactor:	717043
Power Amplifier Fan:	703139
Input Transformer Fan:	703136

7.3.4 FACTORY PART NUMBERS, MODEL 160-ASX (PART NUMBER 143014)

<u>SUB-ASSEMBLY</u>	<u>FACTORY PART No.</u>
LED Display PCB:	139071
Control/Logic PCB:	139078
Auxiliary PCB:	140073
Low Voltage Power Supply/Fan Speed Cont. PCB:	139074
Power Amplifier PCB:	140070
<u>CHASSIS COMPONENT</u>	<u>FACTORY PART No.</u>
Input Circuit Breaker:	716077 or 716071 for CE units
Front Panel Handle:	702112
Trunk Handle:	702130
Output Terminal Block:	705080
External Sense Terminal Block:	705076
Magnetics Module Bypass-Conn. Housing (J20):	714068
Panel-Mount Magnetics Module Connector (P20):	714185
Input Power Cord Strain Relief:	779009
Input Transformer:	531302
Input Power Supply Bridge Rectifier:	743011
Input Power Supply High Voltage DC Capacitor:	720588-41
Output Contactor:	717043
Power Amplifier Fan:	703139
Input Transformer Fan:	703136

7.3.5 FACTORY PART NUMBERS, MODEL 315-ASX (PART NUMBER 143145)

<u>SUB-ASSEMBLY</u>	<u>FACTORY PART No.</u>
LED Display PCB:	139071
Low Voltage Power Supply/Fan Speed Cant. PCB:	139074
Control/Logic PCB:	139078
Power Amplifier PCB:	140076
Output Filter PCB:	140075
Input Filter PCB:	140079
<u>CHASSIS COMPONENT</u>	<u>FACTORY PART No.</u>
Input Circuit Breaker:	716070 or 716075 for CE units
Front Panel Handle:	702112
Output Terminal Block:	705077
External Sense Terminal Block:	705076
Input Power Cord Strain Relief:	779009
Input Transformer:	531317
Input Power Supply Bridge Rectifier:	743005
Input Power Supply High Voltage DC Capacitor:	720588-41
Output Relay:	717040
Power Amplifier Fan:	703145

7.3.6 FACTORY PART NUMBERS, MODEL 320-ASX (PART NUMBER 143149)

<u>SUB-ASSEMBLY</u>	<u>FACTORY PART No.</u>
LED Display PCB:	139071
Low Voltage Power Supply/Fan Speed Cont. PCB:	139074
Power Factor Correction PCB:	139075
Control/Logic PCB:	139078
Power Amplifier PCB:	140076
Output Filter PCB:	140075
Input Filter PCB:	140079
<u>CHASSIS COMPONENT</u>	<u>FACTORY PART No.</u>
Input Circuit Breaker:	716070 or 716075 for CE units
Front Panel Handle:	702112
Output Terminal Block:	705077
External Sense Terminal Block:	705076
Input Power Cord Strain Relief:	779009
Input Transformer (T1):	531318
Low Voltage Input Transformer (T2):	531290
Output Relay:	717040
Power Amplifier Fan:	703145
Input Transformer Fan:	703136

7.3.7 FACTORY PART NUMBERS, MODEL 345-ASX (PART NUMBER 143016)

<u>SUB-ASSEMBLY</u>	<u>FACTORY PART No.</u>
LED Display PCB:	139071
Control/Logic PCB:	139078
Auxiliary PCB:	140073
Low Voltage Power Supply/Fan Speed Cont. PCB:	139074
Power Amplifier PCB:	140070
<u>CHASSIS COMPONENT</u>	<u>FACTORY PART No.</u>
Input Circuit Breaker:	716077 or 716071 for CE units
Front Panel Handle:	702112
Trunk Handle:	702130
Output Terminal Block:	705080
External Sense Terminal Block:	705076
Magnetics Module Bypass-Conn. Housing (J20):	714068
Panel-Mount Magnetics Module Connector (P20):	714185
Input Power Cord Strain Relief:	779009
Input Transformer:	531302
Input Power Supply Bridge Rectifier:	743011
Input Power Supply High Voltage DC Capacitor:	720588-41
Output Contactor:	717043
Power Amplifier Fan:	703139
Input Transformer Fan:	703136

7.3.8 FACTORY PART NUMBERS, MODEL 360-ASX (PART NUMBER 143017)

<u>SUB-ASSEMBLY</u>	<u>FACTORY PART No.</u>
LED Display PCB:	139071
Control/Logic PCB:	139078
Auxiliary PCB:	140073
Low Voltage Power Supply/Fan Speed Cont. PCB:	139074
Power Amplifier PCB:	140070
<u>CHASSIS COMPONENT</u>	<u>FACTORY PART No.</u>
Input Circuit Breaker:	716077 or 716071 for CE units
Front Panel Handle:	702112
Trunk Handle:	702130
Output Terminal Block:	705080
External Sense Terminal Block:	705076
Magnetics Module Bypass-Conn. Housing (J20):	714068
Panel-Mount Magnetics Module Connector (P20):	714185
Input Power Cord Strain Relief:	779009
Input Transformer:	531302
Input Power Supply Bridge Rectifier:	743011
Input Power Supply High Voltage DC Capacitor:	720588-41
Output Contactor:	717043
Power Amplifier Fan:	703139
Input Transformer Fan:	703136

SECTION 7 SERVICE

7.3.9 FACTORY PART NUMBERS, MODEL 3120-ASX (PART NUMBER 143008)

<u>SUB-ASSEMBLY</u>	<u>FACTORY PART No.</u>	
LED Display PCB:	139071	
Control Logic PCB:	134275	
Power Amplifier PCB:	140070	
Relay Delay PCB:	150030	

<u>CHASSIS COMPONENT</u>	<u>FACTORY PART No.</u>	<u>REFERENCE DESIGNATORS</u>
Input Circuit Breaker:	716092	CB1
Front Panel Handle:	702113	
Trunk Handle:	702128	
Output Terminal Block:	(1) 705106 (4) 705111	TB2
External Sense Terminal Block:	705076	
Input Transformer:	531355	T1
Panel-Mount Magnetics Module Connector:	140625	P20
Input Terminal Block:	(1) 705105 (4) 705110	TB1
Input Power Supply Bridge Rectifier:	743001	BR1,2
Input Power Supply High Voltage DC Capacitor:	720219-10	C1-4
Output Contactor:	(2) 717073 (6) 717034	K1,3 K2,4-8
Power Amplifier Fan:	703139	B3,4
Input Transformer Fan:	703145	B1,2
LVPS FUSES FOR 140374 ASSY:	(4) 712060 (2) 712077	F1,2,5,6 F3,4

INDEX

A

Airflow	36, 38
Amps to Volts Ratio Setting	
115-ASX	40
120/320-ASX	40
140/160/345/360-ASX	44
3120-ASX	46
315-ASX	42
AUX I/O	72

B

Bandwidth	23
-----------------	----

C

Calibration	85
Caution	3, 48, 54, 56, 78, 79
Continuous-Self-Calibration	See CSC
Controller	
Manual Controller	4
Programmable Controller	4, 5, 23, 72
CSC	5
Current Limit	23

D

DC Offset	23
Delta	
Connection Form	82
External Sense Connection	73, 74
Input Voltage Forms	58
Load Wiring Requirements	68
Dimensions	23-26
Direct-Coupled	82

E

External Sense	73
----------------------	----

F

Fan Filter	
Cleaning and Removal	84

G

Grounding	69
-----------------	----

I

Input Current	
115-ASX	7
120-ASX	8
140-ASX	8
160-ASX	9

3120-ASX	11
315-ASX	9
320-ASX	10
345-ASX	10
360-ASX	11
Isolation	23

L

Low Frequency	69
---------------------	----

M

Magnetics Module	
140/160/345/360-ASX	44
3120-ASX	46

O

Output Current	12
Overload	12
Over-temperature	80

P

Power Factor	12, 22
--------------------	--------

R

Regulation	22
Remote Interface	
GPIB	38, 70, 72
RS-232	38, 70, 72

S

SCU	5, 70
Shutdown	
Conditions	80
Fault	36
Reset	81
Split phase	See Two Phase
System Control Unit	SCU

T

THD	22
Three Phase	58, 82
Transformer Ratio Setting	
115-ASX	40
120/320-ASX	40
140/160/345/360-ASX	44
3120-ASX	46
315-ASX	42
Transformer-Coupled	12, 22, 63, 69
Transient Response	23
Two Phase	63, 82

INDEX

V

Ventilation..... 38

W

Warning 2, 3, 37, 48, 58, 62

WYE

Connection Form.....82

External Sense Connection..... 74

Input Voltage Forms58

Load Wiring Requirements.....68

SECTION 9

MODIFICATIONS AND CHANGE NOTICES

9 MODIFICATIONS AND CHANGE NOTICES

In cases where customer specified modifications have been installed in the equipment, the modifications will be described on the following pages. If present, be sure to notice any special instructions relative to operation and calibration of the system.

Product change notices or manual errata will also be placed in this section.