

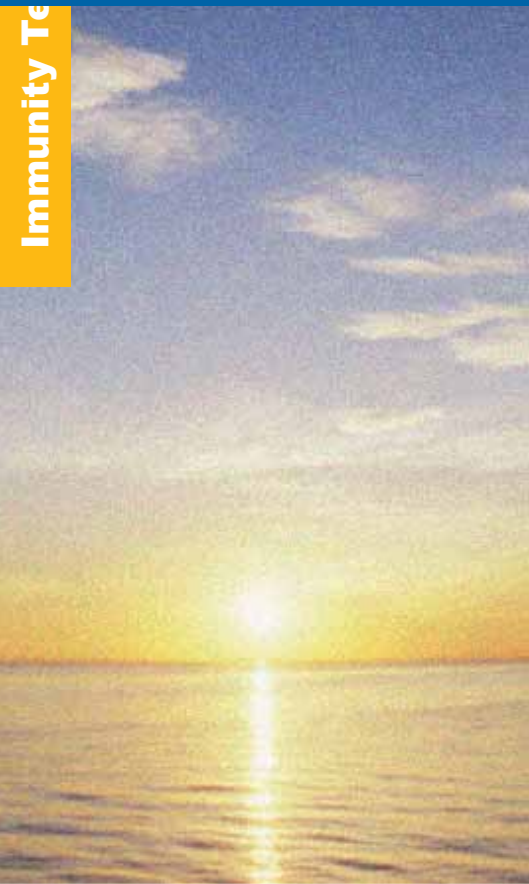

Immunity Te



Transient 3000

Brief Overview of Phenomena. 2
Applicable Standards 3
Test System Overview. 4
Generator Specifications. 10
Accessories and Options. 14
Software 18
EMC PARTNER's Product Range 19

Brief Overview of Phenomena

Transient 3000 Test System generates EMC events that can be observed in the low power distribution system, telecommunication or data lines.

Transient 3000 Test System replicates the following phenomena:

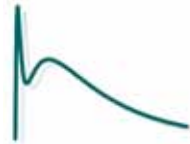

- Electrostatic Discharges (ESD)

A person becomes electrostatically charged by walking over an insulating floor surface. The capacity of the body can be charged to several kilovolts and is discharged when contact is made with an electronic unit or system. The discharge is visible as a spark in many cases and can be felt by the person concerned, who receives a „shock“. The discharges are harmless to humans, but not to sensitive, electronic equipment. The resulting currents cause interference or even component damage.



- Electric Fast Transients (EFT) / Burst

Industrial measurement and control equipment nearly always use conventional control units containing relays or other electro-mechanical switching devices. Fluorescent lamp ballast units, insufficiently suppressed motors (hair dryers, vacuum cleaners, drills, etc.) are found everywhere in the public power supply. All of these are primarily inductive loads which generate interference when switched on or off. EFT events, can cause microprocessor units to malfunction or reset, with corresponding disruption to normal operation.



- Combination Wave Generator (CWG)

Surge events can be generated by lightning phenomena, switching transients or the activation of protection devices in the power distribution system. A surge itself is influenced by the propagation path taken so that impulses from the same event may have different forms depending upon where a measurement is taken. Combination Wave Generators (CWG) simulate a surge event in power lines close to or within buildings. Mostly the disturbances are tolerable because they are single events.



- Voltage Dips/Interrupts

Voltage failures occur following switching operations, short-circuits, response of fuses and when running up heavy loads.

The quality of the electrical power supply is increasingly becoming a central topic of discussion. The interference sources in the mains, caused by electronic power control with non-linear components e.g. thyristors are used more frequently in domestic appliances such as hotplates, heating units, washing machines, television sets, economy lamps, PCs and industrial systems with speed-controlled drives.



- Voltage Variations

Voltage variations are caused by continuously varying loads connected to the power network. The voltage change takes place over a short period of time and depends upon the load. Abrupt variations have the characteristic of a voltage dip with a slow return to nominal voltage.

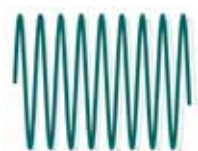

- Power Frequency and Pulse Magnetic Fields

AC current generates a steady magnetic field so that equipment, such as monitors, close to AC power lines could suffer interference.

Lightning strokes or short circuit fault currents in the power network can generate high level short duration magnetic fields.



- Common Mode

Common mode disturbances originate from power line currents and return leakage currents in the earthing system. The disturbances are transmitted into equipment interfaces through capacitive, inductive or resistive coupling. The interference can appear on power and signal ports. Disturbance levels can be relatively high compared to the nominal value but are usually only of short duration.

Applicable Standards

International Electrotechnical Committee (IEC)

IEC 61000-4-2 (Ed2:2008): Testing and measurement techniques - Electrostatic discharge immunity test.

IEC 61000-4-4 (Ed3:2012): Testing and measurement techniques - Electrical fast transient / burst immunity test.

IEC 61000-4-5 (Ed2:2005): Testing and measurement techniques - Surge immunity test.

IEC 61000-4-8 (Ed2:2009): Testing and measurement techniques - Power frequency magnetic field immunity test.

IEC 61000-4-9 (Ed1.1:2001): Testing and measurement techniques - Pulse magnetic field immunity test.

IEC 61000-4-11 (Ed2:2004): Testing and measurement techniques - Voltage dips, short interruptions and voltage variations immunity tests.

IEC 61000-4-16 (Ed1.2:2009): Testing and measurement techniques - Test for immunity to conducted, common mode disturbances in the frequency range 0Hz to 150kHz.

IEC 61000-4-29 (Ed1:2000): Testing and measurement techniques - Voltage dips, short interruptions and voltage variations on d.c. input power port immunity tests.



European Standard (EN)

The same standards are applicable as for IEC (see above).



International Telecommunications Union (ITU)

K.44 (2008): Resistibility tests for telecommunications equipment exposed to overvoltages and overcurrents - Basic recommendation

K.20 (2008): Resistibility of telecommunication equipment installed in a telecommunications centre to overvoltages and overcurrents

K.21 (2008): Resistibility of telecommunication equipment installed in customer premises to overvoltages and overcurrents.

K.45 (2003): Resistibility of telecommunication equipment installed in the access and trunk networks to overvoltages and overcurrents.



American National Standards Institute (ANSI)

C62.41 (1991): IEEE Recommended Practice on Surge Voltages in Low-Voltage AC Power Circuits.



Test System Overview

Test System Features

Transient 3000 CE Test System has many unique and outstanding features:

- Modular design, user configurable
- Environmentally friendly
- Humidity, pressure and temperature sensor measure lab environment
- Automatic frequency detection for mains synchronisation (50 to 400Hz)
- Internal web server
- Ethernet Port for control, communication and report generation
- USB Port: Secure transfer of files, test reports and service data
- Common Mode Disturbances DC to 150kHz 30V continuous, 300V short duration
- ESD 16kV air / 10kV contact discharge
- ESD 16kV continuous firing mode.
- Choice of EFT/Burst modules 4kV or 5kV
- CWG surge up to 4kV/2kA
- AC Magnetic Field up to 1000A/m (with external antenna)
- Impulse Magnetic Field 1200A/m
- AC Interrupt 260V/16A
- AC DIP and VARIATION with internal, external variac or PS3 power supply
- DC Interrupt 110V/16A
- RS485 Port for control of external accessories
- Control of up to two external PS3 power supplies

User Benefits

The technical excellence and many unique features translate directly into benefits for the user:

- Optimized investment. Feature expansion by on-site upgrades
- No down time: Modules can be removed for calibration
- Unparalleled reliability and system up-time
- Display information in any operating system with any web browser
- Customized test report, logo import, graphics, time and date
- Test report includes laboratory environmental conditions
- No proprietary software needed: HTML Report viewable with all browsers
- Active energy control system: Low power consumption, less noise, less heat
- Backwards compatibility: Existing accessories can be used with all models
- 400Hz CDN use for military and avionics testing
- Optimized for CE transient testing: Fulfills IEC basic standard requirements
- Clear menu overview: Structure automatically adjusts to hardware configuration
- Expansion to 3-phase test system up to 100A
- Operating history stored in generator for service
- Modern communication interfaces connect TRA3000 to the world
- Save operator time with the automated test routines and test report facility

Generator

Transient 3000 is a technically advanced CE tester. The revolutionary design reinforces EMC PARTNER's position as a leading technology innovator in the field of EMC transient immunity testers.

- Environmentally Friendly

With less than 50VA power consumption in standby mode and an energy management system that ensures only active circuits are powered, TRA3000 has an extremely low energy footprint. An optimized power consumption also ensures less heat is generated. Coupled to a ventilator with active speed control, noise emissions are drastically reduced. At only 28kg with all modules fitted, TRA3000 also requires less fuel for transportation. The completely modular design, reduces shipping requirements as only specific hardware needs to be sent for calibration. All components and circuits are fully RoHS compliant.

- Modular Architecture

10 different configurations are possible. The unique system architecture enables a "plug-and-play" approach. On-board software automatically recognises the hardware and re-configures the menu structure, downloading module calibration data to ensure generator outputs are always correct. Capable of being equipped with ESD up to 16kV (requires EXT-TRA3000 E), EFT, CWG up to 4.4kV, common mode tests, AC dips/interrupts & variations plus DC interrupts.

- Interface with the World

TRA3000 includes an Ethernet port for communication. It is no longer necessary to use proprietary software. Any PC with Ethernet port and internet browser can access test report and service data. An integrated web server presents data in a clear and easily manageable format. Secure data transfer can also be made using the USB interface and a memory stick.

- Common Mode tester

A module of TRA3000, common mode hardware can be added on site to expand test capability to include IEC61000-4-16. The internal module uses a novel technique to generate common mode interference up to 30V in the range DC to 150kHz. Continuous mode testing can be programmed at fixed frequencies or as a sweep between 9kHz and 150kHz. Test levels are freely programmable to facilitate fault finding during the development phase. External hardware extends common mode levels to 300V for short duration tests.

- Full range of accessories

Backwards compatibility with all existing EMC PARTNER accessories. No redundancy ensures the best possible return on investment. A broad range of accessories enable testing to many applications including:

- Three phase EFT and SURGE up to 100A
- Three phase DIPS/Interrupts up to 75A
- Telecom signal lines, power contact and power induction
- Railway electronics and signaling testing
- Power sub-station control and protection tests
- Electricity meter tests

and much more.....

- Choice of EFT/Burst modules

TRA3000 can be configured with EFT/Burst module for 4kV or 5kV depending on application. Both the 4kV and 5kV have exactly the same footprint and can be exchanged on site without any specialist knowledge.

TRA3000 includes control capability for up to two PS3 power sources. This easy to use power supply for common voltage/frequencies is directly controlled from TRA3000. Outputs can be selected between 230V/50Hz, 115V/60Hz, 230V/16.7Hz and 115V/400Hz and DC. PS3 can be used as the primary power source for any EUT.



TRA3000

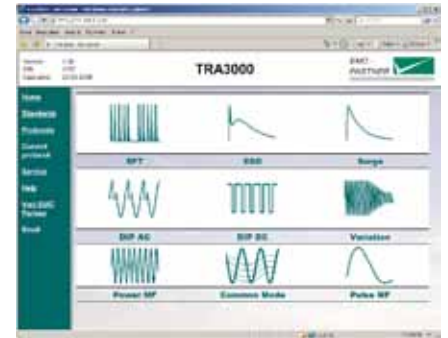

Integrated Web server



Ethernet and USB Ports

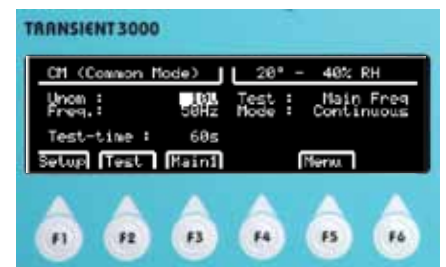

Common Mode Menu

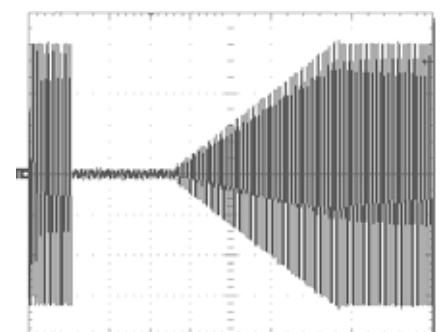

Variations with abrupt and slow changes

Flowcharts

ESD

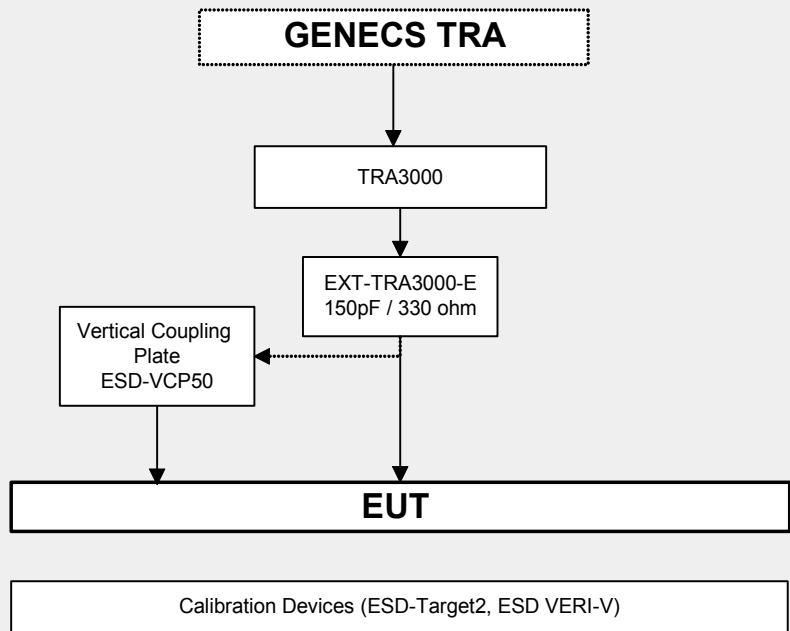

EFT

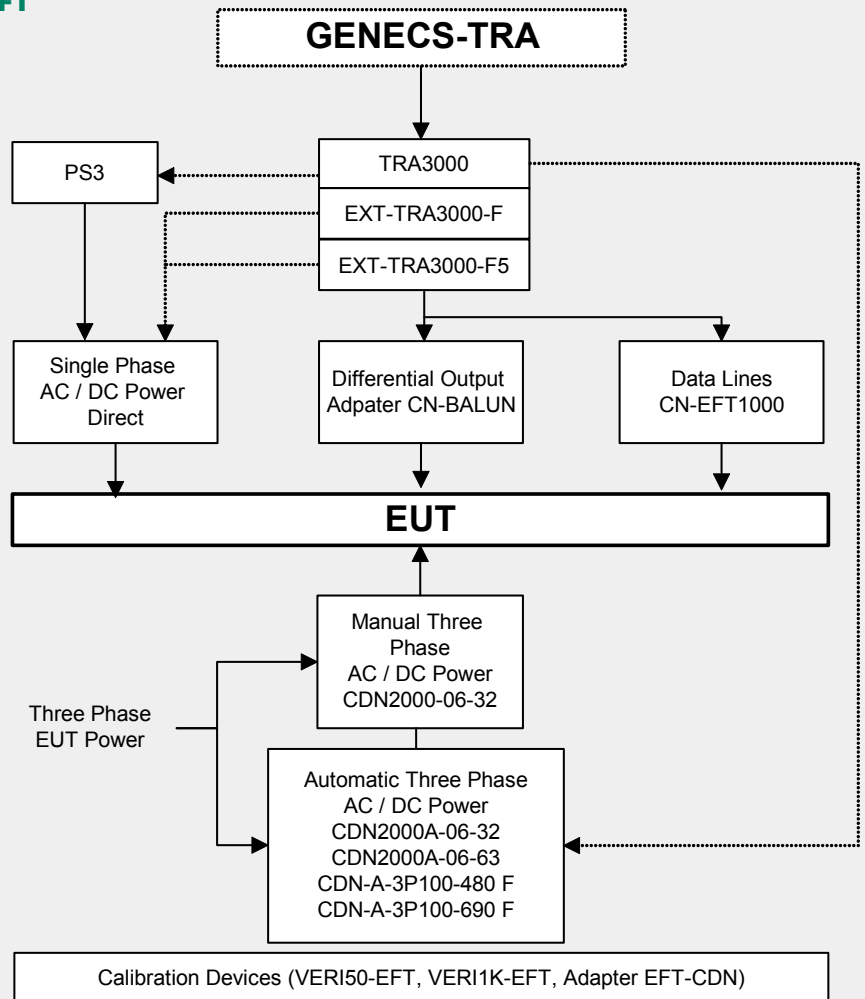

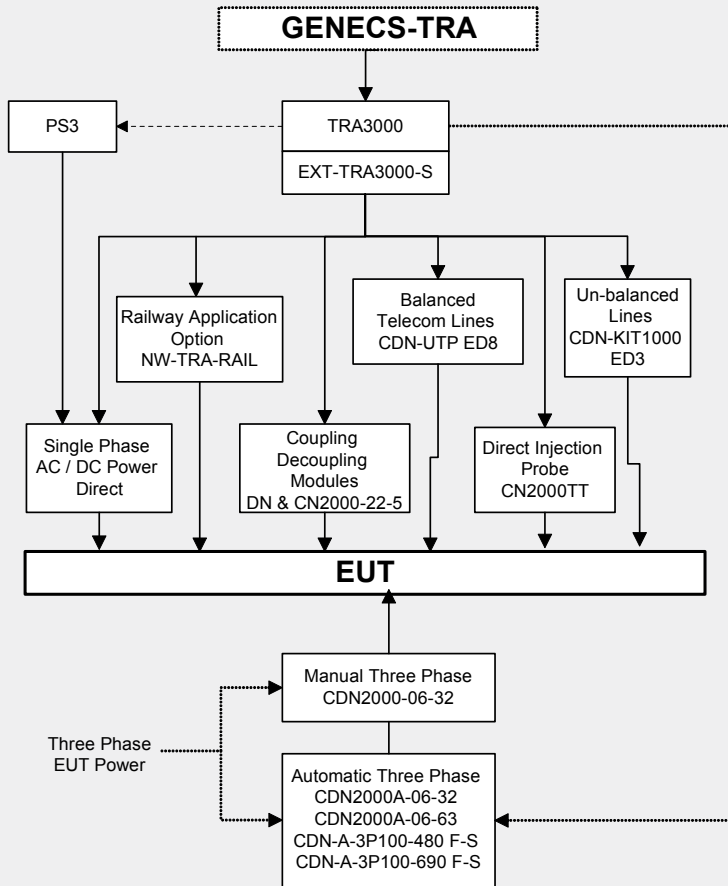

Common Mode

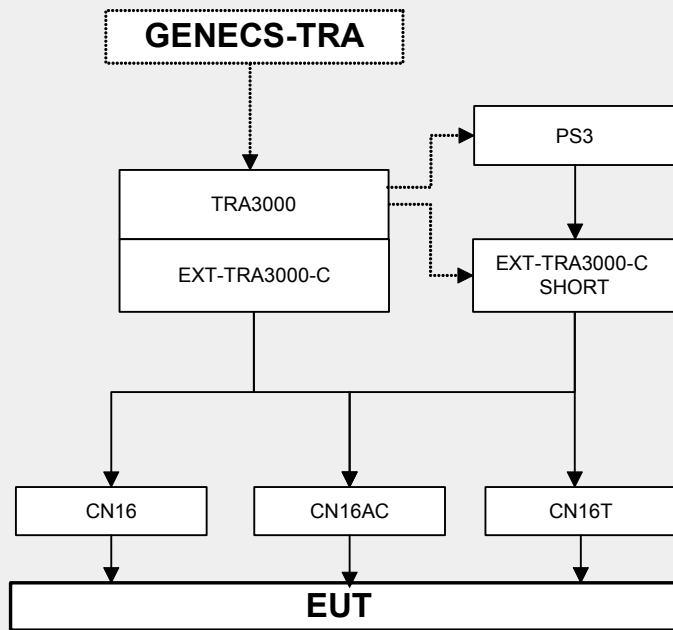

AC and DC Interrupts

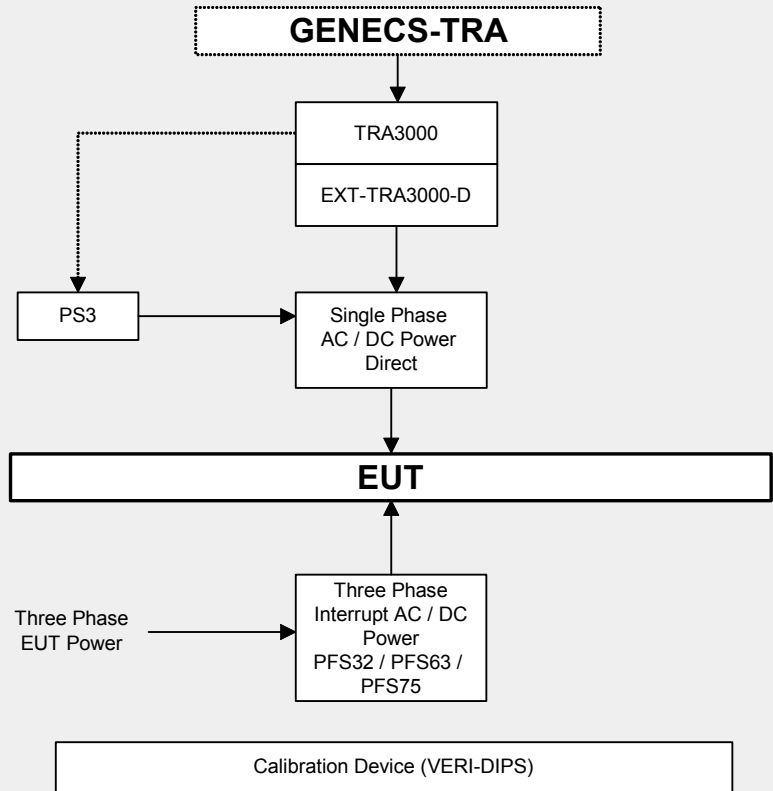

AC DIPS

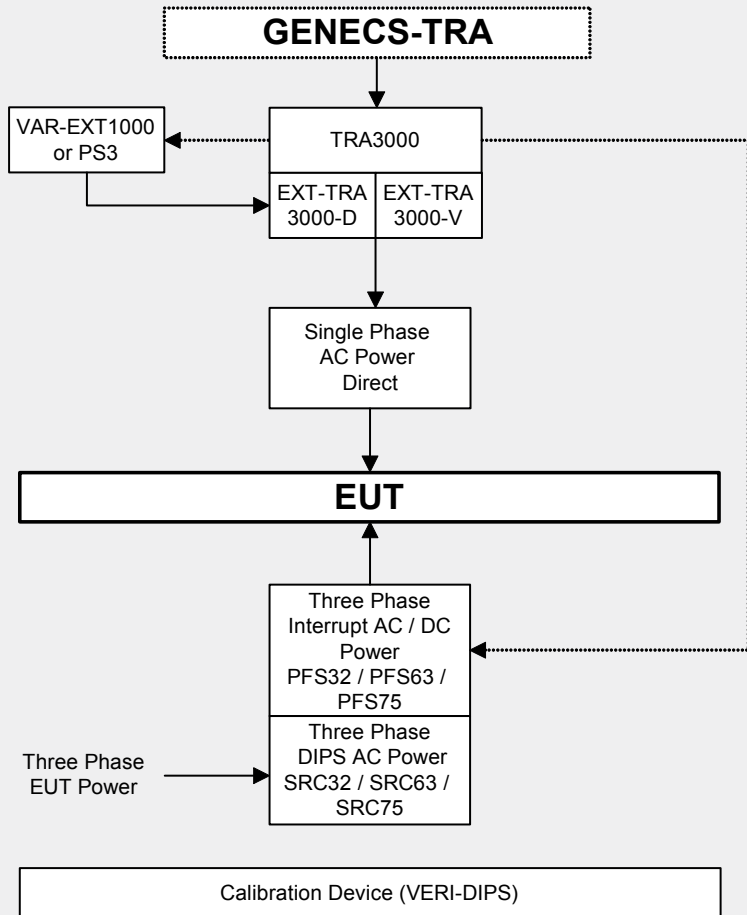

DC DIPS

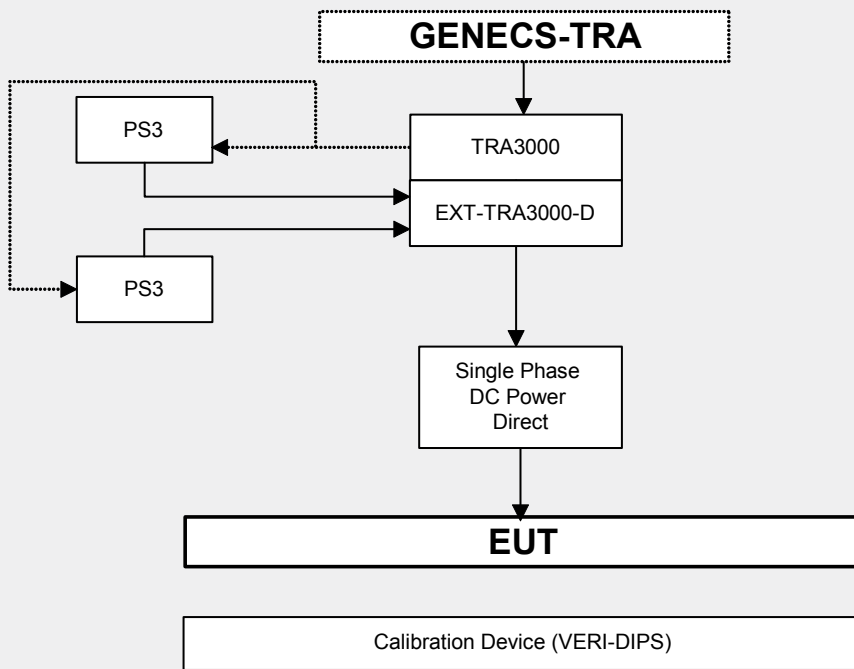

AC MAGNETIC FIELDS

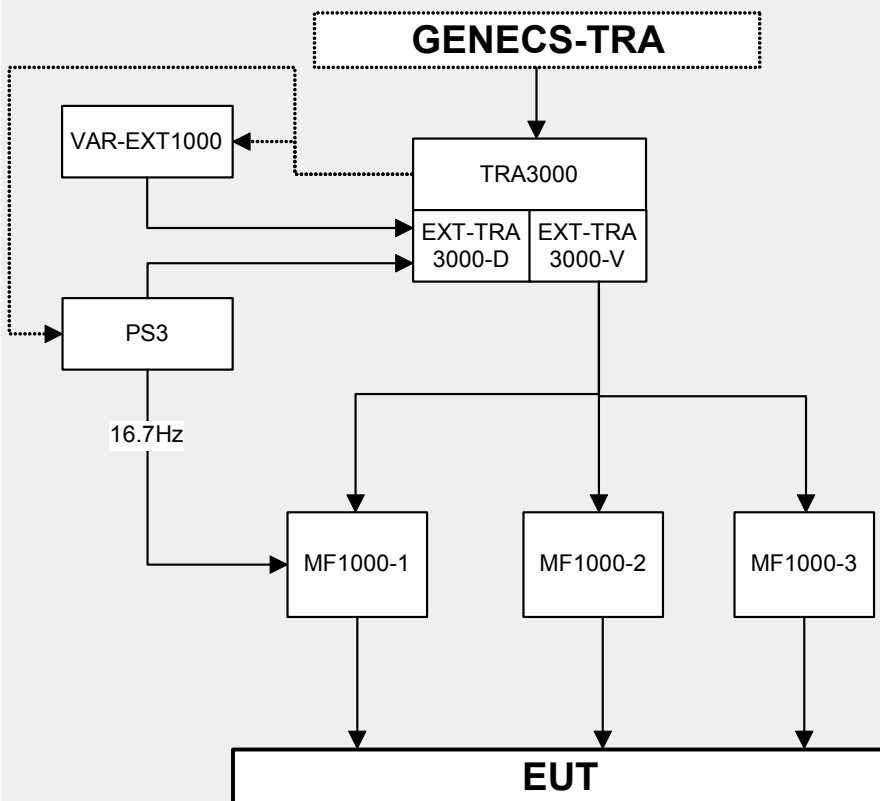

IMPULSE MAGNETIC FIELDS

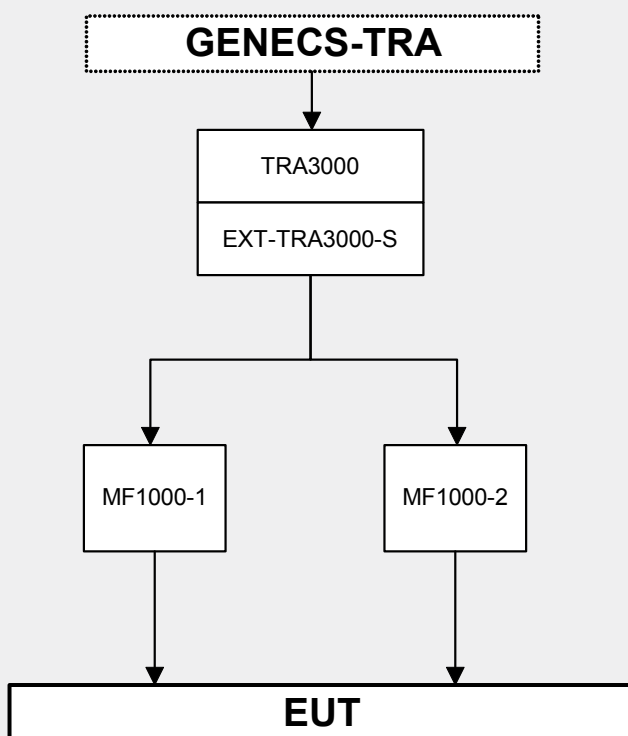

Generator Specifications

Available Modules

TRA3000 BASE

Supply voltage range	80 to 260V / 50Hz & 60Hz
Standby current	50VA
Internal CDN voltage rating	280Vac & 110Vdc
Internal CDN current rating	16Aac & 16Adc
Internal CDN frequency range	50 to 400Hz
Power frequency synchronisation	16Hz up to 400Hz
Coupling path selection EFT	L, N, PE, L+N, L+PE, N+PE, L+N+ PE
Coupling path selection surge	L - N, L - PE, N - PE
Communication Interface	Ethernet
Accessory control interface	RS485
Memory locations	unlimited
Atmospheric measurement	Temperature & Humidity
PS3 control	DC, 16.7Hz, 50Hz, 60Hz, 400Hz
EUT Power monitor	10V = 400Vac
Surge voltage monitor	10V = 4kV
Surge current monitor	10V = 2kA
Trigger	BNC maximum 12V
Trigger mode	Auto, manual
Synchro source	Power, external
Power synchro on/off	0 - 360°
Power switching before / after test	0 up to 60min.

EXT-TRA3000 C	COMMON MODE
Long Duration Voltage Tests	up to 35Vrms
Voltage setting range	0.1 to 35V
Source Impedance	50ohm
Sync turn on for AC	0°
DC switching time	1 up to 5µs
Power frequency tests	DC, 16.7Hz, 50Hz & 60Hz
Power harmonic tests	1Hz up to 150kHz
Sweep time	1 decade / 10 up to 1000s
Step size	2 up to 10%
Short duration tests (with accessories)	up to 300Vrms
EXT-TRA3000 D	DIPS (Interrupt) AC
Voltage range	0 up to 260Vrms
Frequency range	48 up to 60Hz
Rated current	16A (100% to 0% UT)
DIP current 80%	20A (100% to 80% UT & external variac)
DIP current 70%	23A (100% to 70% UT & external variac)
Switching time	1 up to 5µs
DIP modes	< 1 period, > 1 period
Event duration < 1 period	1 up to 29999 dips
Event duration > 1 period	1 up to 29999ms
Inrush current	> 500A
Phase angle switching	0 to 360°
Interrupt type	Synchronous and Asynchronous
Dip impedance	High & Low
DIPS (Interrupt) DC	
Voltage range	0 up to 110V
Rated Current	16A
Switching time	1 up to 5µs
Event duration	1 up to 29999ms
Dip impedance	High & Low
EXF-TRA3000 F	FAST TRANSIENT 4kV
Voltage range	0.25 up to 4.4kV
Source impedance	50ohm
Pulse front time at 50ohm	5ns
Pulse duration at 50ohm	50ns
Spike repetition frequency	up to 1MHz
Programmable parameter ramps	voltage, spike frequency, burst duration, synchronisation
Spike distribution	IEC burst pattern and random
Burst duration	0.01 up to 30ms
Burst repetition	1 up to 1000ms
Polarity	Positive and Negative
EXF-TRA3000 F5	FAST TRANSIENT 5kV
Voltage range	0.25 up to 5.1kV
Source impedance	50ohm
Pulse front time at 50ohm	5ns
Pulse duration at 50ohm	50ns
Spike repetition frequency	up to 1MHz
Programmable parameter ramps	voltage, spike frequency, burst duration, synchronisation
Spike distribution	IEC burst pattern and random
Burst duration	0.01 up to 30ms
Burst repetition	1 up to 1000ms
Polarity	Positive and Negative

EXT-TRA3000 S SURGE Combination Wave Generator (CWG)

Voltage Range	0.25 up to 4.1kV
Pulse front time at open circuit	1.2µs
Pulse duration at open circuit	50µs
Source Impedance	2ohm
Current range	0.125 up to 2.05kA
Pulse front time at short circuit	8µs
Pulse duration at short circuit	20µs
Pulse repetition	up to 20 pulses per minute
Programmable parameter ramps	voltage, polarity, synchronisation

EXT-TRA3000 V VARIATION

Voltage range	0 up to 260V
Rated current	6A (100% to 0% UT)
Test modes	Abrupt, Adjust
Switching time abrupt	1 up to 5µs
Ramp transition time	25 up to 999 periods

EXT-TRA3000 E ESD

Air discharge	0.5 up to 16kV
Contact discharge	0.5 up to 10kV
Voltage increment resolution	1 volt steps
Contact discharge repetition interval	0.05 to 30s
Continuous firing mode (Air)	0.5 up to 16kV
Discharge detection	every pulse or real discharges only
Discharge counter	1 to 29999
Discharge polarity	positive, negative and alternating
Holding time	5s
Programmable parameter ramps	voltage, polarity
Discharge trigger	manual or automatic

STANDARDS	COMMON MODE (INT)					COMMON MODE (EXT)					
	TRA3000 BASE	EFT/Burst	SURGE	DIPS (INTERRUPT)	VARIAC	VAR-EXT1000	MF1000-1	CN16 (T)	CN-EFT1000	PS3	EXT-TRA3000 E
IEC61000-4-2	●										●
IEC61000-4-4	●	●							●		
IEC61000-4-5	●		●			□					
IEC61000-4-8	●				□		●			□ ¹	
IEC61000-4-9	●		●				●				
IEC61000-4-11	●			●	□ ²	□ ²				□ ³	
IEC61000-4-16	●				●		●				□
IEC61000-4-29	●			●					● ⁴		

● = necessary □ = options

1. PS3 can be used for magnetic field testing including 16.7Hz
2. Internal and external variac >500A inrush current
3. PS3 ca. 100A inrush current
4. Requires 2 x PS3

Accessories and Options

COMMON MODE TESTS DC to 150kHz

EXT-TRA3000 C SHORT

Extends TRA3000 C with short test. DC, 16.7Hz, 50Hz and 60Hz up to 300V. External box with 50 ohm output. Programing and control from TRA3000 front panel.

CN16

Coupling network for common mode testing DC to 150kHz. Coupling onto DC, AC single and three phase supplies.

CN16T

T coupling network for common mode testing DC to 150kHz. Coupling onto telecom lines. One telecom pair per CN16T.

CN16-22-7 C

Coupling network for 2 port common mode testing in accordance with IEC 60255-22-7. $R = 220 \text{ ohm}$ and $C = 0.47 \mu\text{F}$.

CN16-22-7 D

Coupling network for 2 port common mode testing in accordance with IEC 60255-22-7. $R = 100 \text{ ohm}$ and $C = 0.1 \mu\text{F}$.

MF-COIL-HAND

MF-COIL-HAND extends TRA3000 C for magnetic field test in accordance with EN55103-2. Inhomogeneous field in range 0.01 A/m up to 4 A/m .

Frequency range 50Hz up to 10kHz

MF-HELMHOLTZ

MF-HELMHOLTZ extends TRA3000 C for magnetic field test in accordance with EN55103-2. Homogeneous field in range 0.01 A/m up to 10 A/m .

Frequency range 50Hz up to 10kHz

AC and Impulse Magnetic Fields

MF1000-1, MF1000-2 and MF1000-3

Applicable standards are IEC 61000-4-8 for a.c. and IEC 61000-4-9 for impulse magnetic fields.

Coil antenna MF1000-1 and MF1000-2 can be mounted on stands that facilitate testing in all axis.

Antenna	Coil dimensions	AC magnetic fields (50/60Hz)	Impulse magnetic fields (8/20 μs)
MF1000-1	1m x 1m	1 up to 130A/m	0.1 up to 1.5kA/m
MF1000-2	1m x 2.6m	1 up to 110A/m	0.1 up to 1.1kA/m
MF1000-3	1m x 1m	0.3 up to 1kA/m	

MF1000-1 and MF1000-2 antenna can also be used with the damped oscillatory wave generators to fulfill the IEC61000-4-10 requirement. For further details please refer to the Oscillatory Wave Test System brochure.

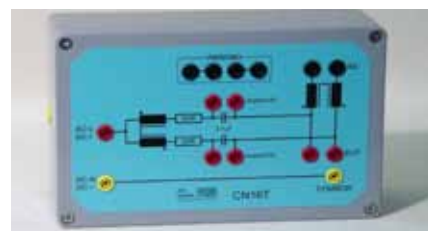
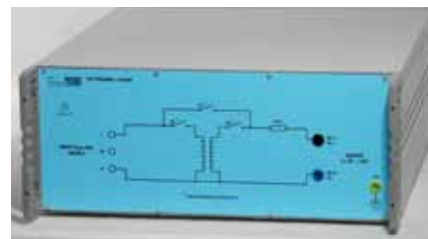

3-Phase EFT, SURGE and Ringwave CDNs



CDN2000-06-32 for Three Phase Coupling

Add three phase capability with automatic or manual three phase coupling networks. The CDN2000A-06-32 and CDN2000-06-32, can be used for EFT, CWG surge and ring wave. Coupling path selection is either automatic under software control, or manual on the CDN front panel. All coupling networks fulfill the requirements laid down in the IEC 61000-4-4, IEC 61000-4-5, IEC 61000-4-12 (ring wave) and ANSI C62.41 standards.

280V Lx to N/PE, 480V Lx-Lx, 480V Lx/N-PE

OPTION 480V / CMC enables coupling according to ANSI C62.41 L1+L2+L3+N to PE.



CDN2000A-06-63 for Three Phase Coupling

Add higher current three phase capability with automatic coupling network CDN2000A-06-63. This can be used for EFT, CWG surge and ring wave. Coupling path selection is automatic under software control. This coupling network fulfills the requirements laid down in the IEC 61000-4-4, IEC 61000-4-5, IEC 61000-4-12 (ring wave) and ANSI C62.41 standards.

280V Lx to N/PE, 480V Lx-Lx, 480V Lx/N-PE



CDN-A-3P100-480 F / F-S for 100A three Phase Coupling

Three phase CDN with line voltages L to N/PE=280V and L to L=480V, line current 100A per phase. Automatic coupling path selection for EFT or EFT and SURGE controlled by TRA2000, TRA2004, TRA2006, TRA3000.

CDN-A-3P100-690 F / F-S for 100A three Phase Coupling

Three phase CDN with line voltages L to N/PE=398V and L to L=690V, line current 100A per phase. Automatic coupling path selection for EFT or EFT and SURGE controlled by TRA2000, TRA2004, TRA2006, TRA3000 and MIG0603INx.

CDN-A-3P200-480 F / F-S for 200A three Phase Coupling

Three phase CDN with line voltages L to N/PE=280V and L to L=480V, line current 200A per phase. Automatic coupling path selection for EFT or EFT and SURGE controlled by TRA2000, TRA2004, TRA2006, TRA3000 and MIG0603INx.

CDN-A-3P200-690 F / F-S for 200A three Phase Coupling

Three phase CDN with line voltages L to N/PE=398V and L to L=690V, line current 200A per phase. Automatic coupling path selection for EFT or EFT and SURGE controlled by TRA2000, TRA2004, TRA2006, TRA3000 and MIG0603INx.



CDN-A-06-32-AC-DC

CDN-A-06-32-AC-DC Surge and EFT CDN

Combined automatic CDN for Solar Inverter testing on 2 strings. DC+ and DC- up to 1000V / 32A and AC 3-Phase 690V / 32A. Surge combination wave and EFT in one unit.

EFT / Burst

CN-EFT1000

Capacitive coupling clamp 100ohm according to IEC 61000-4-4 including 1m coax cable with BNC connectors.



VERI-CP-EFT

Transducer plate for capacitive coupling clamp calibration. Connector HV BNC with 15cm strap to bond to the reference ground plane.



VERI-CP-EFT

CN-BALUN

Balanced/unbalanced transmission line transformer for EFT and 1MHz damped sine according to ANSI/IEEE C.37.90. Including coaxial cable with HV-BNC plugs (3x 0.5m), test tip + HV-BNC adapter (1 red, 1 black) and HV-BNC connector (2x).



VERI50EFT

VERI50EFT

50ohm termination with high voltage BNC connector and integrated divider for EFT calibration / verification in accordance with IEC 61000-4-4 Ed2.



VERI1KEFT

VERI1KEFT

1kOhm termination with high voltage BNC connector and integrated divider for EFT calibration / verification in accordance with IEC 61000-4-4 Ed2.

TELECOM TESTS ITU-T K20, K21, K44

NW-K44PC

Power contact network for telecom testing. For use with DIPS circuit of TRA3000 and TRA2006.

TRA OPTION NW-K44PI

Power induction network for telecom testing. Requires NW-K44PC.

PCPI160E

Power contact current limiting resistor network for telecom testing. For use with NW-K44PC.

Two PCPI160E units are required for 4 wire testing.

CDN-UTP ED3 and CDN-UTP8 ED3

The CDN-UTP ED3 is a sophisticated coupling and de-coupling network for superimposing surge impulses on balanced communication lines in accordance with IEC 61000-4-5 (Figure 12: unshielded symmetrical interconnection lines), ITU-K20, K21 and FCC part 68. The maximum data rate is 100Mb/s.

It is designed for 1.2/50µs and 10/700µs pulses up to 6.6kV.

CDN-UTP8 ED3 has 4 pairs (8 lines) and a maximum data rate of 1Gb/s.



CDN-UTP8

SURGE NETWORKS



CDN-KIT1000 ED3



CDN-KIT1000 ED3

Surge coupling-decoupling network for data lines according to IEC 61000-4-5. Comprises one universal coupling module, one low frequency and one high frequency decoupling module.

NW-TRA-RAIL

Applicable standards are IEC 60571 Ed. 2.0b, EN 50155 and RIA12.

TRA2000 and option NW-TRA-RAIL fulfill the waveform A impulse requirement.

Waveform A: 5/50 μ s (1.8kV), Zout 100ohm.

In combination with the ESD3000DM8 which generates the higher level waveform B impulse.

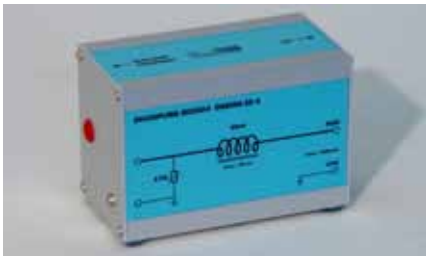

DN2000-22-5

DN2000-22-5

Decoupling module for IEC 60255-22-5 applications. 20mH inductance, 275V varistor to protect auxilliary equipment.

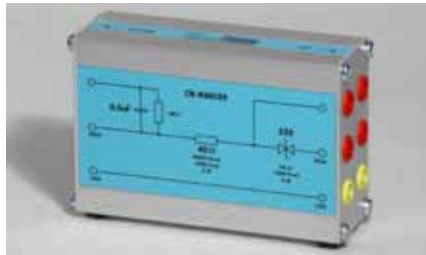

CN-R40C05

CN-R40C05

Surge coupling network according to IEC61000-4-5 and EN50121-4 railway applications. 2 each 40ohm resistor and 0.5 μ F capacitors. Can be used together with CDN2000-06-32 for testing on power lines



CN16-450C

CN16-450C

Single phase CDN for superimposing surge and EFT into power lines. EUT power supply up to 16A at 115V 400Hz. For use ONLY with TRA2004 or TRA2006.



ELECTROSTATIC DISCHARGE

EXT-TRA3000E

ESD discharge module to fulfill IEC 61000-4-2 requirements. Self contained unit with high voltage generation. For full details, please refer to brochure "ESD Testers". For use ONLY with TRA3000.



VCP50

Vertical coupling plate to perform indirect Contact discharge tests. Set includes ground- ing cable with 2 x 470kohm series resistors.

AC DIPS INTERRUPTS AND VARIATION

PFS

PFS extends the Transient Test System to include three phase testing of AC and DC interrupts up to 480V in accordance with IEC 61000-4-34.

Available with different current ratings:

- PFS32 for interruptions up to 32A per phase
- PFS63 for interruptions up to 63A per phase
- PFS75 for interruptions up to 75A per phase

SRC

SRC extends the Transient Test System to include three phase testing of AC dips up to 480V in accordance with IEC 61000-4-34. Requires one PFS unit.

Available with different current ratings:

- SRC32 for dips up to 32A per phase
- SRC63 for dips up to 63A per phase
- SRC75 for dips up to 75A per phase

VAR-EXT1000

External 16A variac module extends the internal capability of TRA3000 for higher powered EUTs.

VERI-DIPS

Measuring set for calibration / verification of the EUT inrush current.

DIPS100E

100ohm non-inductive resistor for calibration of dips/interrupts switching times.

DC DIPS and INTERRUPTS

PFS100DC

Extends TRA3000 D for dc interrupt testing. DC power fail simulator for I_{max} 100Adc. V_{max} 600Vdc. Output floating DC+, DC- and ground.

Automatic control only from TRA3000 D front panel.

GENERAL

ATS

Humidity Temperature and Pressure sensor connects to TRA3000 front panel in series with ESD module. Atmospheric conditions are registered for inclusion in the test report.



PFS32 and SRC32





PS3



PS3 SOFT-EXT

PS3

Easy to use power supply for common voltage/frequencies. Control from TRA3000. Output selected between 230V/50Hz, 115V/60Hz, 230V/16.7Hz and 115V/400Hz. 3000W capability.

For use with TRA3000 for AC and DC DIPS testing.

PS3SOFT-EXT

PS3SOFT-EXT extends PS3 for applications such as IEC 61000-4-28 and magnetic field at 16.7Hz.

Software

Software is an integral part of every modern test system. TRA3000 introduces a new dimension to transient test equipment. Two layers of software increase user access and comfort.

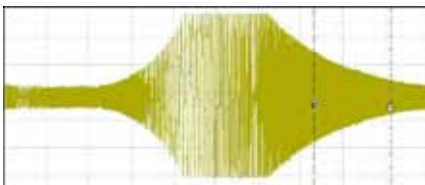
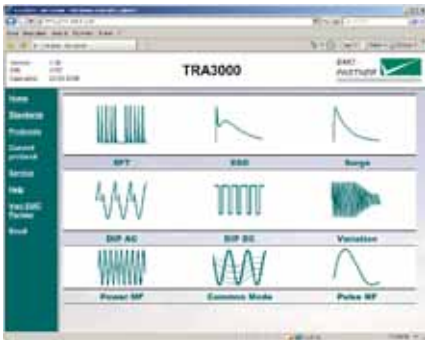

Web Server

Use any PC with any operating system and internet browser to connect to the internal web server. This enables access to test report and service data either directly on a PC internet browser or using the USB memory stick. Customize the test report by uploading company logo and test information from the USB memory stick. Conversely, by simply selecting the GOTO USB button, test report and service information can be saved directly to the USB memory stick. Communication with a PC is by Ethernet, which again reduces dependency on obsolete or expensive interfaces.

Remote control from a PC is best achieved with the OPTICAL LINK and the GENECS-TRA software package.

GENECS-TRA

Providing backwards compatibility with all existing EMC PARTNER test instrumentation, GENECS-TRA accepts ethernet IP addresses. GENECS-TRA has been extended to include test sequencing and enhanced reporting functionality enabling complex sequences of up to 99 tests to be linked. In addition to remote programming and control of the generators, test report information is available to word processing or other evaluation programs such as EXCEL.

CM-SWEEP

An option for the GENECS-TRA software. CM-SWEEP enables user programmable frequency and amplitude variations to be programmed in the Common Mode module. Sweep events can be programmed with linear or logarithmic progressions over the frequency range 9kHz to 150kHz.

OPTICAL LINK

The 10m long fibre optic cable provides EMC isolation between TRA3000 and a remote control PC. The remote control PC will not be disturbed by the impulses generated by TRA3000 and the operator can locate the PC in a less hostile environment. The optical isolation allows up to 4 TRA3000 generators with Ethernet connections to be linked to one PC.

EMC PARTNER's Product Range

The Largest Range of Impulse Test Equipment up to 100kA and 100kV.

Immunity Tests

Transient Test System can be used to perform all EMC tests on electronic equipment. ESD, EFT, surge, AC dips, AC magnetic field, surge magnetic field, common mode, damped oscillatory and DC dips tests are available as stand-alone or combined test instruments. A large range of accessories for different applications is available: three phase couplers up to 690V/100A, telecom and data line couplers, verification sets, magnetic field coils. Immunity test systems fulfill IEC and EN 61000-4-2, -4, -5, -8, -9, -11, -12, -16, -18, -29.

TRA3000 and ESD3000 Ideal for CE testing
Easily extended to meet other applications



Lightning Tests

A range of test equipment and accessories for aircraft, military and telecom applications. Complete solutions including all hardware and software to meet the requirements of RTCA / EUROCAE DO160 / ED14 for indirect lightning on aircraft systems, MIL-STD-461 tests CS106, CS115, CS116, for military vehicles, ITU-T .K44 basic and enhanced tests for impulse, power contact and power induction, FCC part 68 for telecom equipment testing.

MIG2000-6 – a flexible solution for military and
avionics applications



Component Tests

Modular impulse generators (MIG) for transient component testing on: varistors, gas discharge tubes (GDT), surge protective devices (SPD), XY capacitors, circuit breakers, watt-hour meters, protection relays, insulation material, suppressor diodes, connectors, chokes, fuses, resistors, emc-gaskets, cables, etc. Manual or fully automated solutions are available up to 100kA (8/20us) and 144kV (1.2/50us).

MIG1212CAP – an automatic
8 bank capacitor test system



Emission Measurements

One unit performs all measurements on the power supplies of electronic equipment and products for the CE-Mark. HAR1000 uses a novel technique to deliver clean power source for the EUT in a compact and lightweight form. The system includes all hardware and software including line impedance networks, control and evaluation software. A basic 1-phase system can be easily extended to 3-phase by adding 2 further phases. HARCS Immunity software further expands the system by adding interharmonic tests, voltage variation and ripple on DC tests. Complies with IEC / EN 61000-3-2, -3 IEC / EN 61000-4-13, -14,

HAR1000-3P and HARCS software
a complete test system



System Automation

As addition to the basic generators, a range of accessories are available to enhance capability. Test cabinets, test pistols, adapters and software, simplify interfacing with the EUT.

PS3 programmable source is an EMC hardened supply for frequencies from 16.7Hz to 400Hz. Frequency variation tests can be made using the PS3-SOFT-EXT. Complies with IEC / EN 61000-4-28

PS3 - programmable source
Ideal for EMC applications



For further information please do not hesitate to contact EMC PARTNER's representative in your region. You will find a complete list of our representatives and a lot of other useful information on our website:

www.emc-partner.com

The Headquarters in Switzerland

EMC PARTNER AG
Baselstrasse 160
CH - 4242 Laufen
Switzerland

Phone: +41 61 775 20 30
Fax: +41 61 775 20 59
Email: sales@emc-partner.ch
Web-Site: www.emc-partner.com

Your local representative

