

METRIC

MIL-STD-188-125-2

3 March 1999

DEPARTMENT OF DEFENSE INTERFACE STANDARD

**HIGH-ALTITUDE ELECTROMAGNETIC PULSE (HEMP) PROTECTION
FOR GROUND-BASED C⁴I FACILITIES PERFORMING CRITICAL,
TIME-URGENT MISSIONS**

**PART 2
TRANSPORTABLE SYSTEMS**



AMSC N/A

AREA TCSS

DISTRIBUTION STATEMENT A. Approved for public release; distribution is unlimited.

MIL-STD-188-125-2

HIGH-ALTITUDE ELECTROMAGNETIC PULSE (HEMP) PROTECTION FOR GROUND-BASED C⁴I FACILITIES PERFORMING CRITICAL, TIME-URGENT MISSIONS, PART 2: TRANSPORTABLE SYSTEMS

FOREWORD

1. This military standard is approved for use by all Departments and Agencies of the Department of Defense (DoD).
2. Originally, Military Standard 188 (MIL-STD-188) covered technical standards for tactical and long-haul communications, but later evolved through revisions (MIL-STD-188A, MIL-STD-188B) into a document applicable to tactical communications only (MIL-STD-188C).
3. The Defense Information Systems Agency (DISA) published DISA circulars (DISAC), promulgating standards and engineering criteria applicable to the long-haul Defense Communication System and to the technical support of the National Military Command System.
4. As a result of a Joint Chiefs of Staff action, standards for all military communications are now being published in a MIL-STD-188 series of documents. The MIL-STD-188 series is subdivided into a MIL-STD-188-100 series, covering common standards for tactical and long-haul communications; a MIL-STD-188-200 series, covering standards for tactical communications only; and a MIL-STD-188-300 series, covering standards for long-haul communications only. Emphasis is being placed on developing common standards for tactical and long-haul communications, published in the MIL-STD-188-100 series.
5. This two-part document contains technical requirements and design objectives for high-altitude electromagnetic pulse (HEMP) protection of ground-based systems and facilities that are nodes in HEMP-hardened networks for performing critical and time-urgent command, control, communications, computer, and intelligence (C⁴I) missions. Part 1 of the document addresses HEMP hardening for fixed facilities; this Part 2 addresses transportable systems. The requirements are stringent, in order to avoid both damage and functional upsets that prevent mission accomplishment within operationally prescribed timelines. The standards apply uniformly to all systems and facilities in the end-to-end chain, since disruption of a single node may result in network failure.
6. Performance, acceptance test, and verification test requirements are contained in the body of the standard. HEMP-unique acceptance and verification test techniques are provided in Appendices A, B, C, and D.
7. Implementation of MIL-STD-188-125-1 is supported by MIL-HDBK-423, "High-Altitude Electromagnetic Pulse (HEMP) Protection for Fixed and Transportable Ground-Based Facilities,

MIL-STD-188-125-2

Volume I: Fixed Facilities." The handbook also includes planning, management, logistics, and data requirements for HEMP protection acquisition programs and hardness maintenance/ hardness surveillance requirements for operational systems and facilities. Some sections of MIL-HDBK-423, Volume I, are also applicable to MIL-STD-188-125-2. References to sections of MIL-HDBK-423 are made within this standard, where applicable.

8. Beneficial comments (recommendations, additions, deletions) and any pertinent data which may be of use in improving this document should be addressed to: Defense Threat Reduction Agency/TEL-NSSE, 6801 Telegraph Road, Alexandria, VA 22310-3398, by using the Standardization Document Improvement Proposal (DD Form 1426) appearing at the end of this document or by letter.

MIL-STD-188-125-2**CONTENTS**

<u>PARAGRAPH</u>	<u>PAGE</u>
FOREWORD	ii
1. SCOPE	1
1.1 Purpose	1
1.2 Scope	1
1.3 Applications	1
1.4 Objectives	1
2. APPLICABLE DOCUMENTS	2
2.1 General	2
2.2 Government documents	2
2.2.1 Specifications, standards, and handbooks	2
2.2.2 Other Government documents, drawings, and publications	3
2.3 Non-Government publications	3
2.4 Order of precedence	4
3. DEFINITIONS	5
3.1 Acronyms used in this standard	5
3.2 Sources for definitions	7
3.3 Definitions	8
3.3.1 Aperture point-of-entry (POE)	8
3.3.2 Conductive POE	8
3.3.3 Continuous wave (CW) immersion	8
3.3.4 Corrective maintenance	8
3.3.5 Electromagnetic barrier	8
3.3.6 Electromagnetic closure	9
3.3.7 Electromagnetic stress	9
3.3.8 HEMP acceptance test	9
3.3.9 HEMP hardness	9
3.3.10 HEMP hardness assurance	9
3.3.11 HEMP hardness configuration baseline	9
3.3.12 HEMP hardness critical item (HCI)	9
3.3.13 HEMP hardness critical process (HCP)	10
3.3.14 HEMP hardness maintenance (HM)	10
3.3.15 HEMP hardness maintenance and hardness surveillance (HM/HS)	10
3.3.16 HEMP hardness surveillance (HS)	10
3.3.17 HEMP hardness surveillance/reverification testing	10
3.3.18 HEMP protection measures	10

MIL-STD-188-125-2**CONTENTS**

<u>PARAGRAPH</u>		<u>PAGE</u>
3.3.19	Intrasite cable	10
3.3.20	Long-line cable.....	10
3.3.21	Long-line protection module (LLPM).....	10
3.3.22	Low-risk HEMP hardening.....	11
3.3.23	Main barrier electrical POE protective device	11
3.3.24	Mission-critical equipment (MCE).....	11
3.3.25	Norton equivalent circuit or Norton source.....	11
3.3.26	Penetration entry area.....	11
3.3.27	Performance degradation.....	11
3.3.28	Point-of-entry (POE).....	11
3.3.29	POE protective device or POE treatment.....	11
3.3.30	Preventive maintenance	12
3.3.31	Primary special electrical POE protective device.....	12
3.3.32	Protected volume	12
3.3.33	Pulsed current injection (PCI).....	12
3.3.34	Residual internal stress	12
3.3.35	Retrofit HEMP hardening.....	12
3.3.36	Secondary special electrical POE protective device.....	12
3.3.37	Shielded enclosure leak detection system (SELDS).....	12
3.3.38	Special protective measures.....	12
3.3.39	Special protective volume.....	13
3.3.40	Subsystem HEMP shield.....	13
3.3.41	Threat-level illumination	13
3.3.42	Verification testing	13
3.3.43	Vulnerability threshold (of an equipment)	13
3.3.44	Waveguide below cutoff (WBC).....	13
3.3.45	Waveguide-below-cutoff array.....	13
4.	GENERAL REQUIREMENTS.....	14
4.1	General	14
4.1.1	HEMP protection overview	14
4.1.2	Integration with related requirements.....	14
4.2	Hardness program overview	14
4.3	HEMP hardening design.....	15
4.3.1	Subsystem HEMP shields	15
4.3.2	POEs.....	15
4.3.3	External cable plant	15
4.3.4	Mission-critical equipment.....	15

MIL-STD-188-125-2**CONTENTS**

<u>PARAGRAPH</u>		<u>PAGE</u>
4.3.4.1	MCE within the electromagnetic barrier.....	16
4.3.4.2	MCE outside the electromagnetic barrier	16
4.3.5	HEMP-hardened electrical power	16
4.3.6	Special protective measures	16
4.4	HEMP testing.....	16
4.4.1	Quality assurance program	17
4.4.2	Acceptance testing	17
4.4.3	Verification testing	17
4.5	HM/HS	17
4.5.1	HM/HS program development.....	17
4.5.2	HM/HS program implementation.....	17
5.	DETAILED REQUIREMENTS.....	18
5.1	HEMP protection topology	18
5.1.1	Transportable system topology	18
5.1.2	Electromagnetic barrier topology.....	18
5.1.3	Penetration entry area.....	19
5.1.4	External electrical cabling	20
5.1.4.1	Intrasite cabling	20
5.1.4.2	Long-line cabling.....	22
5.2	Transportable system grounding	22
5.2.1	Equipotential ground plane	22
5.2.2	Grounding to the subsystem HEMP shields.....	22
5.2.3	Long-line protection module grounding.....	23
5.3	Subsystem HEMP shields	23
5.3.1	Shielding effectiveness.....	23
5.3.2	Shield configuration.....	23
5.3.3	Shield production quality assurance	23
5.3.4	Shield acceptance testing	24
5.3.4.1	Subsystem shield modifications.....	24
5.4	Architectural POEs.....	24
5.4.1	HEMP protection for architectural POEs.....	24
5.4.2	Personnel entryways and exits	24
5.4.2.1	Shielded doors.....	24
5.4.2.2	Shielded vestibules	24
5.4.3	Equipment accesses.....	24
5.4.4	Acceptance testing for architectural POE protective measures	25
5.5	Mechanical POEs	26

MIL-STD-188-125-2**CONTENTS**

<u>PARAGRAPH</u>		<u>PAGE</u>
5.5.1	HEMP protection for mechanical POEs	26
5.5.2	Piping POEs	26
5.5.3	Ventilation POEs	26
5.5.4	Acceptance testing for mechanical POE protective devices	28
5.6	Structural POEs	28
5.6.1	HEMP protection for structural POEs	28
5.6.2	Acceptance testing for structural POE treatments	28
5.7	Electrical POEs and long-line protection modules	29
5.7.1	Electrical POEs	29
5.7.1.1	HEMP protection for electrical POEs	29
5.7.1.2	Intrasite power line POE protective device requirements.....	29
5.7.1.3	Intrasite control, signal, and data line POE protective device requirements.....	38
5.7.1.4	Antenna line POE protective device requirements	39
5.7.1.4.1	Core conductor injection requirements for receive-only antenna line POE protective devices	39
5.7.1.4.2	Core conductor injection requirements for transmit antenna line POE protective devices	39
5.7.1.4.3	Shield injection requirements for antenna line POE protective devices.....	40
5.7.1.5	Acceptance testing of electrical POE protective devices.....	40
5.7.2	Long-line protection modules	40
5.7.2.1	General requirements for LLPMs.....	41
5.7.2.2	Power line LLPM requirements	41
5.7.2.3	Control, signal, and data line LLPM requirements.....	41
5.7.2.4	Acceptance testing of LLPMs.....	46
5.8	Special protective measures	46
5.8.1	MCE outside the subsystem electromagnetic barriers.....	46
5.8.1.1	RF communications antennas outside the subsystem electromagnetic barriers	47
5.8.2	MCE that is inside a subsystem electromagnetic barrier and fails verification testing.....	47
5.8.3	Special protective volumes	47
5.8.3.1	Special protective volumes for piping POEs.....	47
5.8.3.1.1	Special waveguide requirements	47
5.8.3.1.2	Special protective barriers for piping POEs.....	49
5.8.3.2	Special protective volumes for electrical POEs	49

MIL-STD-188-125-2**CONTENTS**

<u>PARAGRAPH</u>		<u>PAGE</u>
5.8.3.2.1	Primary special electrical POE protective device requirements.....	49
5.8.3.2.2	Secondary special electrical POE protective device requirements.....	49
5.8.3.2.3	Special protective barriers for electrical POEs.....	49
5.8.3.2.4	MCE in special protective volumes.....	50
5.8.4	Acceptance testing for special protective measures	50
5.8.4.1	Special protective measures for MCE	50
5.8.4.2	Special protective barriers	50
5.9	Reliability and maintainability	50
5.10	Safety and human engineering.....	50
5.11	Testability	51
5.12	Corrosion control	51
5.13	Configuration management.....	51
5.14	Verification testing	51
5.14.1	CW immersion testing	51
5.14.2	PCI verification testing.....	52
5.14.3	Threat-level illumination testing.....	53
5.14.4	Verification testing of special protective measures	53
5.14.4.1	Verification testing of MCE hardened with special protective measures.....	53
5.14.4.2	Verification testing of special protective barriers.....	54
5.15	HM/HS program requirements	54
5.15.1	Hardness surveillance/reverification test procedures.....	54
5.15.2	Maintenance and inspection procedures	54
5.15.3	Supply support requirements	55
5.15.4	Training requirements.....	55
5.15.5	Technical data	55
5.15.6	Delivery	55
5.15.7	Implementation.....	55
6.	NOTES	56
6.1	Intended use.....	56
6.2	Issues of DoDISS.....	56
6.3	Subject term (key word) listing.....	56

MIL-STD-188-125-2**CONTENTS**

<u>FIGURE</u>		<u>PAGE</u>
1	Typical transportable system barrier topology	19
2	Penetration entry area placement	20
3	External cable descriptions	21
4	Minimum HEMP shielding effectiveness requirements (measured in accordance with procedures of Appendix A)	23
5	Typical vestibule entryway.....	25
6	Typical waveguide-below-cutoff piping POE protective devices.	27
7	Typical waveguide-below-cutoff array ventilation POE protective device.....	28
8	Typical electrical POE protective device.....	30
9	Typical special protective volumes.....	48

TABLE

I	Norton source parameters, waveforms, and acceptance test loads for electrical POE injection specifications	31
II	Maximum allowable residual internal response norms for electrical POE injection specifications	35
III	Norton source parameters, waveforms, and acceptance test loads for LLPM injection specifications	42
IV	Maximum allowable residual response norms for LLPM injection specifications	44
V	Verification test program options.....	52

APPENDIX

A	SHIELDING EFFECTIVENESS (SE) TEST PROCEDURES FOR TRANSPORTABLE GROUND-BASED SYSTEMS ...	57
B	PULSED CURRENT INJECTION (PCI) TEST PROCEDURES FOR TRANSPORTABLE GROUND-BASED SYSTEMS ...	71

MIL-STD-188-125-2

CONTENTS

<u>APPENDIX</u>		<u>PAGE</u>
C	CONTINUOUS WAVE (CW) IMMERSION TEST PROCEDURES FOR TRANSPORTABLE GROUND-BASED SYSTEMS ...	106
D	THREAT-LEVEL ILLUMINATION TEST PROCEDURES FOR TRANSPORTABLE GROUND-BASED SYSTEMS ...	122
CONCLUDING MATERIAL.....		137

MIL-STD-188-125-2

1. SCOPE

1.1 Purpose. This standard establishes minimum requirements and design objectives for high-altitude electromagnetic pulse (HEMP) hardening of transportable¹ ground-based systems that perform critical, time-urgent command, control, communications, computer, and intelligence (C⁴I) missions. Systems required to fully comply with the provisions of the standard will be designated by the Joint Chiefs of Staff, a Military Department Headquarters, or a Major Command.

1.2 Scope. This standard prescribes minimum performance requirements for low-risk protection from mission-aborting damage or upset due to HEMP threat environments defined in MIL-STD-2169. The standard also addresses minimum testing requirements for demonstrating that prescribed performance has been achieved and for verifying that the installed protection measures provide the operationally required HEMP hardness for the completed system. If the prescribed testing results in any hardware damage or functional upsets, the operational authority for the system will make the determination whether the observed event is mission aborting.

1.3 Applications. This standard defines the design and testing criteria for specifically designated transportable ground-based systems in HEMP-hardened, critical, time-urgent C⁴I networks. Such systems include subscriber terminals and data processing centers, transmitting and receiving communications stations, and relay systems. The standard applies to both new systems and modifications of existing systems. Although only local portions of system interconnects are addressed, it is assumed that survivable long-haul communications paths, fiber-optic links, or other hardened interconnects between systems will be provided as required for mission accomplishment.

1.4 Objectives. Survivable C⁴I capabilities are essential to a credible military deterrent. This standard supports nuclear survivability objectives by providing a standardized, low-risk protection approach for transportable ground-based systems in HEMP-hardened C⁴I networks. These uniform requirements ensure balanced HEMP hardening for all critical systems and facilities in the network.

¹ This part of the standard addresses transportable systems only. A transportable ground-based C⁴I system, for purposes of this standard, consists of equipment in shelters that provide survivable C⁴I capabilities at a relocatable deployment site. HEMP hardening requirements for fixed ground-based facilities are contained in MIL-STD-188-125-1.

MIL-STD-188-125-2

2. APPLICABLE DOCUMENTS

2.1 General. The documents listed in this section are specified in sections 3, 4, and 5 of this standard. This section does not include documents cited in other sections of this standard or recommended for additional information or as examples. While every effort has been made to ensure the completeness of this list, document users are cautioned that they must meet all specified requirements documents cited in sections 3, 4, and 5 of this standard, whether or not they are listed.

2.2 Government documents.

2.2.1 Specifications, standards, and handbooks. The following specifications, standards, and handbooks form a part of this document to the extent specified herein. Unless otherwise specified, the issues of these documents are those listed in the effective issue of the Department of Defense (DoD) Index of Specifications and Standards (DoDISS) and supplement thereto (see 6.2).

STANDARDS

FEDERAL

FED-STD-1037 – Telecommunications: Glossary of
Telecommunication Terms

DEPARTMENT OF DEFENSE

MIL-STD-100 – Engineering Drawing Practices
MIL-STD-188-125-1 – High-Altitude Electromagnetic Pulse (HEMP)
Protection for Ground-Based C⁴I Facilities
Performing Critical, Time-Urgent Missions, Part 1:
Fixed Facilities
MIL-STD-2169 – High-Altitude Electromagnetic Pulse (HEMP)
Environment (U) (document is classified Secret)

HANDBOOKS

DEPARTMENT OF DEFENSE

MIL-HDBK-419 – Grounding, Bonding and Shielding for
Electronic Equipment and Facilities

MIL-STD-188-125-2

- MIL-HDBK-423 – High-Altitude Electromagnetic Pulse (HEMP)
Protection for Fixed and Transportable
Ground-Based Facilities, Volume I: Fixed Facilities

(Unless otherwise indicated, copies of the above specifications, standards, and handbooks are available from the Standardization Document Order Desk, 700 Robbins Avenue, Building 4D, Philadelphia, PA 19111-5094. Requests for MIL-STD-2169 should indicate that the document is classified, and contractor requests require endorsement by the DoD contracting activity.)

2.2.2 Other Government documents, drawings, and publications. The following other Government documents, drawings, and publications form a part of this standard to the extent specified herein. Unless otherwise specified, the issues are those cited in the solicitation.

PUBLICATIONS

- JOINT PUB 1-02 – Department of Defense Dictionary of Military and
Associated Terms

FORMS

- DD Form 2639 – Hardness Critical Label
- DD Form 2640 – Hardness Critical Tag

(Copies of documents required by contractors in connection with specific acquisition functions should be obtained from the contracting activity or as directed by the contracting officer.)

2.3 Non-Government publications. The following document forms a part of this standard to the extent specified herein. Unless otherwise specified, the issues of the documents which are DoD adopted are those listed in the issue of the DoDISS cited in the solicitation. The issues of documents not listed in the DoDISS are the issues of the documents cited in the solicitation (see 6.2).

- ANSI C63.14 – American National Standard Dictionary for
Technologies of Electromagnetic Compatibility (EMC),
Electromagnetic Pulse (EMP), and Electrostatic
Discharge (ESD)

MIL-STD-188-125-2

(Applications for copies should be addressed to the Institute for Electrical and Electronics Engineers [IEEE], 445 Hoes Lane, Post Office Box 1331, Piscataway NJ 08855-1331).

2.4 Order of precedence. In the event of a conflict between the text of this document and the references cited herein, the text of this document takes precedence. Nothing in this document, however, supersedes applicable laws and regulations unless a specific exemption has been obtained.

MIL-STD-188-125-2**3. DEFINITIONS**

3.1 Acronyms used in this standard. The acronyms used in this standard are defined as follows:

- a. A – Ampere
- b. ac – Alternating Current
- c. C⁴I – Command, Control, Communications, Computer, and Intelligence
- d. cm – Centimeter
- e. CW – Continuous Wave
- f. dB – Decibel
- g. dBm – Power in dB referred to one milliwatt
- h. dc – Direct Current
- i. DoD – Department of Defense
- j. DoDISS – Department of Defense Index of Specifications and Standards
- k. DR – Dynamic Range
- l. EMP – Electromagnetic Pulse
- m. ESA – Electric Surge Arrester
- n. F/O – Fiber Optics
- o. ft – Foot
- p. FWHM – Full-Width at Half-Maximum Amplitude
- q. GHz – Gigahertz
- r. GPIB – General Purpose Interface Bus

MIL-STD-188-125-2

s.	HCI	–	Hardness Critical Item
t.	HCP	–	Hardness Critical Process
u.	HEMP	–	High-Altitude Electromagnetic Pulse
v.	HM	–	Hardness Maintenance
w.	HM/HS	–	Hardness Maintenance/Hardness Surveillance
x.	HS	–	Hardness Surveillance
y.	Hz	–	Hertz
z.	IAW	–	In Accordance With
aa.	IEEE	–	Institute of Electrical and Electronics Engineers
bb.	in	–	Inch
cc.	kA	–	Kiloampere
dd.	kHz	–	Kilohertz
ee.	LLPM	–	Long-Line Protection Module
ff.	m	–	Meter
gg.	mA	–	Millampere
hh.	MCE	–	Mission-Critical Equipment
ii.	MHz	–	Megahertz
jj.	MR	–	Measurement Range
kk.	ms	–	Millisecond
ll.	ns	–	Nanosecond
mm.	PCI	–	Pulsed Current Injection

MIL-STD-188-125-2

nn.	POE	–	Point-of-Entry
oo.	RF	–	Radio Frequency
pp.	s	–	Second
qq.	SE	–	Shielding Effectiveness
rr.	SE _M	–	Shielding Effectiveness (Magnetic)
ss.	SE _{PW}	–	Shielding Effectiveness (Plane Wave)
tt.	SE _R	–	Shielding Effectiveness (Resonant Range)
uu.	SELDS	–	Shielded Enclosure Leak Detection System
vv.	SNR	–	Signal-to-Noise Ratio
ww.	TEMPEST	–	A term used to describe a methodology for controlling radiated and conducted emanations of classified information
xx.	V	–	Volt
yy.	WBC	–	Waveguide below cutoff
zz.	μs	–	Microsecond
aaa.	Ω	–	Ohm

3.2 Sources for definitions. Sources for definitions of terms used in this standard, in order of decreasing priority, are as follows:

- a. FED-STD-1037, “Telecommunications: Glossary of Telecommunication Terms,”
- b. JOINT PUB 1-02, “Department of Defense Dictionary of Military and Associated Terms,”

MIL-STD-188-125-2

c. MIL-STD-188-125-1, “High-Altitude Electromagnetic Pulse (HEMP) Protection for Ground-Based C⁴I Facilities Performing Critical, Time-Urgent Missions, Part 1: Fixed Facilities,”

d. MIL-HDBK-423, “High-Altitude Electromagnetic Pulse (HEMP) Protection for Fixed and Transportable Ground-Based C⁴I Facilities, Volume I: Fixed Facilities,”

e. ANSI C63.14, “American National Standard Dictionary for Technologies of Electromagnetic Compatibility (EMC), Electromagnetic Pulse (EMP), and Electrostatic Discharge (ESD),”

f. MIL-HDBK-419, “Grounding, Bonding and Shielding for Electronic Equipment and Facilities,”

g. MIL-STD-100, “Engineering Drawing Practices.”

3.3 Definitions.

3.3.1 Aperture point-of-entry (POE). An intentional or inadvertent hole, crack, opening, or other discontinuity in the HEMP shield surface. Intentional aperture POEs are provided for personnel and equipment entry and egress and for fluid flow (ventilation and piped utilities) through the electromagnetic barrier.

3.3.2 Conductive POE. An electrical wire or cable or other conductive object, such as a metal rod, that passes through the electromagnetic barrier. Conducting POEs are also called penetrating conductors.

3.3.3 Continuous wave (CW) immersion. A test method for measuring the electromagnetic responses induced on an electromagnetic barrier and other items of interest (e.g., cables or conduits) illuminated by a CW electric or magnetic field.

3.3.4 Corrective maintenance. All unscheduled maintenance actions. HEMP corrective maintenance action is undertaken when excessive degradation or failure of a hardness critical item is detected, to restore the HEMP protection to a satisfactory condition and level of performance. Corrective maintenance includes removal of the defective item, repair or replacement, reassembly, and checkout of the completed work.

3.3.5 Electromagnetic barrier. The topologically closed surface created to prevent or limit HEMP fields and conducted transients from entering the enclosed space. The electromagnetic barrier consists of the HEMP shield and POE treatments, and it encloses the protected volume and special protective volumes, if required.

MIL-STD-188-125-2

3.3.6 Electromagnetic closure. A treatment to prevent excessive electromagnetic field leakage at an aperture POE. Examples of closure techniques at a seam between two metal plates include welding, brazing, or soldering and metal-to-metal contact under pressure applied with a mechanical fastening.

3.3.7 Electromagnetic stress. A voltage, current, charge, or electromagnetic field that acts on an item of equipment. If the electromagnetic stress exceeds the vulnerability threshold of the equipment, mission-aborting damage or upset may occur.

3.3.8 HEMP acceptance test. An acceptance test of a system, subsystem, or component performed to ensure that specified HEMP performance characteristics have been met. HEMP acceptance tests, conducted near the conclusion of a hardening production or installation contract, are tests for the purpose of demonstrating that at least minimum performance requirements of the HEMP protection measures have been achieved before the unit is accepted by the Government from the contractor.

3.3.9 HEMP hardness. A quantitative description of the resistance of a system or component to temporary or permanent malfunction or degraded performance induced by HEMP. HEMP hardness is achieved through adhering to appropriate design specifications and is verified by one or more test and analysis techniques.

3.3.10 HEMP hardness assurance. Procedures and activities performed during the construction or production phase to confirm that the end product meets the HEMP hardness design specifications. Hardness assurance includes those aspects of quality assurance that deal with hardening component and subassembly testing, acceptance testing, and initial verification testing to confirm that design specifications have been met.

3.3.11 HEMP hardness configuration baseline. The functional and physical characteristics of the HEMP protection measures achieved in the “as-built” system and documented in the system drawings and technical manuals.

3.3.12 HEMP hardness critical item (HCI). An item at any assembly level having performance requirements for the purpose of providing HEMP protection. Nuclear HCIs provide protection from environments produced by a nuclear event or are specially designed to operate under nuclear weapon (device)-derived stresses. HEMP HCIs are the elements of the HEMP protection. A hardness critical assembly is a top-level definable unit of HEMP HCIs and other components, such as mounting hardware and terminal posts, that may not be hardness critical.

MIL-STD-188-125-2

3.3.13 HEMP hardness critical process (HCP). A process, specification, or procedure that must be followed exactly to ensure that the associated HCI attains its required performance.

3.3.14 HEMP hardness maintenance (HM). Preventive maintenance (e.g., adjustments or cleaning) and corrective maintenance (e.g., repairs or replacements) on the HEMP protection measures or the HCIs and assemblies. These HM activities are intended to eliminate faults or to preserve specified HEMP protection performance levels.

3.3.15 HEMP hardness maintenance and hardness surveillance (HM/HS). The combined preventive maintenance, inspection, test, and repair activities accomplished on a HEMP-protected operational system to ensure that HEMP hardness is retained throughout the system life cycle. HM/HS, along with hardness assurance and hardness configuration management, constitute a total hardness assurance, maintenance, and surveillance program.

3.3.16 HEMP hardness surveillance (HS). Inspections and tests of the HEMP protection measures or the HCIs and assemblies. These HS activities are intended to observe and monitor the condition and performance of the hardening elements and to detect faults.

3.3.17 HEMP hardness surveillance/reverification testing. Testing conducted at prescribed intervals during the operational phase of the system life cycle for evaluating whether the HEMP protection measures continue to provide the required HEMP hardness. HS/reverification test requirements are established in the technical manual. They typically require repetition of some or all of the test procedures from the original verification test program.

3.3.18 HEMP protection measures. The electromagnetic barrier and all special protective measures installed for the purpose of hardening the mission-critical equipment against the HEMP environment.

3.3.19 Intrasite cable. An external system cable, outside the subsystem electromagnetic barriers, that meets the length and routing restrictions of this standard and is used to interconnect subsystems or to connect a subsystem to equipment outside the barriers.

3.3.20 Long-line cable. An external cable, outside the subsystem electromagnetic barriers, used to connect the transportable system to equipment located beyond the deployment site. Subsystem and equipment interconnecting cables that do not meet the length and routing restrictions of this standard are also designated as long-line cables.

3.3.21 Long-line protection module (LLPM). A HEMP protective device provided to isolate the intrasite cable plant and mission-critical subsystems and equipment from transients induced on long-line cables by the HEMP threat environment.

MIL-STD-188-125-2

3.3.22 Low-risk HEMP hardening. A hardening technique that features a high-quality electromagnetic barrier with minimized and protected POEs. Virtually all mission-critical communications-electronics and support equipment are placed in the protected volume enclosed by the barrier and operate in a relatively benign electromagnetic environment, isolated from the external HEMP stresses. The low-risk approach results in a well-defined HEMP protection configuration with inherent testability.

3.3.23 Main barrier electrical POE protective device. A protective device installed on an electrical conductor that penetrates from the system exterior, through the HEMP shield, and into the protected volume. Main barrier protective devices must meet the performance requirements of this standard.

3.3.24 Mission-critical equipment (MCE). All equipment required to directly support a critical mission, success or failure of which could affect the outcome of battle. In the context of this standard, MCE refers to all communications-electronics and support equipment that must be protected in order to perform critical trans- and post-HEMP attack missions.

3.3.25 Norton equivalent circuit or Norton source. A circuit, consisting of a current source in parallel with an impedance, that has equivalent characteristics to those of the represented circuit over the operating range of interest.

3.3.26 Penetration entry area. That area of the electromagnetic barrier where long penetrating conductors (such as an electrical power feeder) and piping POEs are concentrated.

3.3.27 Performance degradation. Changes in one or more performance characteristics of a component or assembly, such that it no longer operates within the required functional range.

3.3.28 Point-of-entry (POE). A location on the electromagnetic barrier where the shield is penetrated and HEMP energy may enter the protected volume unless an adequate POE protective device is provided. POEs are classified as aperture POEs or penetrating conductors according to the type of penetration. They are also classified as architectural, mechanical, structural, or electrical POEs according to the engineering discipline in which they are usually encountered.

3.3.29 POE protective device or POE treatment. The protective measure used to prevent or limit HEMP energy from entering the protected volume at a POE. Common POE protective devices include waveguides below cutoff and closure plates for aperture POEs, and filters and electric surge arresters on penetrating conductors. The three categories of electrical POE protective devices installed on penetrating conductors are main barrier POE protective devices, primary special POE protective devices, and secondary special POE protective devices.

MIL-STD-188-125-2

3.3.30 Preventive maintenance. Scheduled maintenance actions. These actions are performed on a regular basis. Preventive maintenance includes scheduled adjustments, cleaning, and replacement of items with limited lifetimes.

3.3.31 Primary special electrical POE protective device. A protective device installed on an electrical conductor that penetrates from the system exterior, through the HEMP shield, into a special protective volume. A primary special POE protective device is designed to provide the maximum attenuation possible without interfering with the normal operational electrical signals that are routed on the penetrating conductor.

3.3.32 Protected volume. The three-dimensional space enclosed by the electromagnetic barrier, but not including those spaces that are within special protective volumes.

3.3.33 Pulsed current injection (PCI). A test method for measuring performance of a POE protective device on a penetrating conductor. A HEMP threat-relatable transient is injected on the penetrating conductor at a point outside the electromagnetic barrier, and the residual internal transient stress is measured inside the barrier.

3.3.34 Residual internal stress. The electromagnetic voltages, currents, charges, or fields that originate from the HEMP environment and penetrate into the protected volume after attenuation by elements of the electromagnetic barrier.

3.3.35 Retrofit HEMP hardening. An action taken to modify in-service HEMP protective equipment. Retrofit HEMP hardening is the installation or substantial upgrade of the HEMP protection measures for an existing system or equipment.

3.3.36 Secondary special electrical POE protective device. A protective device installed on an electrical conductor that penetrates from a special protective volume into the main protected volume. It is used only when necessary to augment the attenuation provided by the primary special POE protective device and the connected equipment. The total attenuation through the primary special POE protective device, the connected equipment, and the secondary special POE protective device must meet the performance requirements of this standard.

3.3.37 Shielded enclosure leak detection system (SELDS). Any of a class of commercially available instruments designed for checking shielding effectiveness in the magnetic field test regime. Most of these instruments operate at one or more discrete frequencies, often of the order of 100 kHz.

3.3.38 Special protective measures. All HEMP hardening measures required in addition to implementation of the electromagnetic barriers. Special protective measures are necessary for

MIL-STD-188-125-2

MCE outside the barrier, for MCE that are within the protected volume and experience damage or upset during verification testing, and in cases requiring a special protective volume.

3.3.39 Special protective volume. A HEMP-protected space within a subsystem electromagnetic barrier, where electromagnetic stresses due to HEMP may exceed the residual internal stress limits for the protected volume. The special protective barrier may be a separate shield with protected penetrations; more commonly, shielded cables or conduits and equipment cabinets and closed piping systems are used to provide the needed electromagnetic isolation from the protected volume.

3.3.40 Subsystem HEMP shield. The continuous conductive housing that substantially reduces the coupling of HEMP electric and magnetic fields into the subsystem protected volume. The subsystem HEMP shield is part of the electromagnetic barrier.

3.3.41 Threat-level illumination. Exposure of systems or equipment to simulated HEMP fields with characteristics similar to the environment defined in MIL-STD-2169. Threat-level illumination tests are conducted as part of the system hardness verification program.

3.3.42 Verification testing. Tests conducted for demonstrating that the installed HEMP protection measures provide the required HEMP hardness. These tests are performed after the production and acceptance testing are complete and after the equipment is installed and functioning, to determine if the operational system suffers mission-aborting damage or upset due to simulated HEMP excitations. Verification is normally a Government-conducted test and is not part of a system production contract.

3.3.43 Vulnerability threshold (of an equipment). The minimum stress level that causes the equipment to suffer definite degradation. In the context of this standard, the vulnerability threshold is the minimum electromagnetic stress that causes mission-aborting damage or upset.

3.3.44 Waveguide below cutoff (WBC). A metallic waveguide whose primary purpose is to attenuate electromagnetic waves at frequencies below the cutoff frequency (rather than propagating waves at frequencies above cutoff). The cutoff frequency is determined by the transverse dimensions and geometry of the waveguide and properties of the dielectric material in the waveguide.

3.3.45 Waveguide-below-cutoff array. An assembly of parallel waveguides below cutoff, with adjacent cells usually sharing common cell walls. A waveguide-below-cutoff array is used when the area of the shield aperture required to obtain adequate fluid flow is larger than the permissible area of a single waveguide below cutoff.

MIL-STD-188-125-2

4. GENERAL REQUIREMENTS

4.1 General.

4.1.1 HEMP protection overview. The need exists for uniform and effective hardening, hardness verification, and hardness maintenance/hardness surveillance of transportable ground-based C⁴I systems that require network interoperability during and after exposure to HEMP environments. In critical time-urgent applications where some momentary upsets, as well as damage, may be mission-aborting, the hardening requirements include high-integrity shielding, POE protection, and special protective measures. Since normal operational experience may not indicate the condition of the HEMP protection measures, thorough verification testing and hardness maintenance/hardness surveillance after deployment are necessary.

4.1.2 Integration with related requirements. Elements of the HEMP protection can serve multiple purposes. For example, the electromagnetic barrier can also be used to meet emanations security requirements. HEMP-hardening measures shall be integrated with those of other electromagnetic requirements, such as electromagnetic interference/electromagnetic compatibility, lightning protection, and TEMPEST, and with treatments for other hardening requirements. The performance requirements in this standard are for HEMP protection only; increases in the required performance may be needed for protection from other electromagnetic environments, in addition to HEMP.

4.2 Hardness program overview. Hardness programs² for transportable ground-based systems being HEMP hardened in accordance with (IAW) requirements of this standard shall implement DoD acquisition policy and procedures. Design and engineering, fabrication, installation, and testing activities shall be organized to accomplish the following objectives:

- a. To provide a HEMP-protected system design based on verifiable performance specifications,
- b. To verify hardness levels through a cost-effective program of testing and analysis,
- c. During the acquisition process, to develop a maintenance/surveillance program that supports the operational phase of life-cycle HEMP hardness,

² HEMP planning, analysis, test procedures, and test reporting documentation, and requirements for hardness maintenance and hardness surveillance program development and execution are described in MIL-HDBK-423. While the handbook specifically addresses fixed facilities, much of the programmatic information is also applicable to transportable systems.

MIL-STD-188-125-2

d. To establish the HEMP configuration baseline, consisting of documentation of the functional and physical characteristics of the HEMP protection measures, and baseline performance data.

4.3 HEMP hardening design. System protection against the HEMP threat environment specified in MIL-STD-2169 shall be achieved by enclosing the MCE in electromagnetic barriers and with special protective measures, as required. If the transportable system is made up of separate transportable elements (herein referred to as subsystems), the MCE in each of the subsystems shall be enclosed in an independent electromagnetic barrier. Each subsystem electromagnetic barrier shall consist of a HEMP shield and protective devices for all POEs. Special protective measures shall be implemented in special cases where HEMP hardness cannot be achieved with an electromagnetic barrier alone (see 4.3.6). Reliability, maintainability, configuration management, safety and human engineering, testability, corrosion control and prevention, and standard drawing practices shall be incorporated into the HEMP protection design.

4.3.1 Subsystem HEMP shields. The subsystem HEMP shields shall be continuous conductive enclosures that meet or exceed shielding effectiveness requirements of this standard (see 5.3.1). The shields are normally constructed of metal, such as steel, copper, or aluminum. Other materials may be used if they can provide the required shielding effectiveness and are fully compatible with the POE protective treatments and grounding requirements.

4.3.2 POEs. The number of subsystem shield POEs shall be limited to the minimum required for operational, life-safety, and habitability purposes. All POEs shall be HEMP protected with POE protective devices that satisfy performance requirements of this standard (see 5.4 through 5.7).

4.3.3 External cable plant. The external cable plant shall consist of intrasite and long-line cables that are not enclosed within electromagnetic barriers and are, therefore, exposed to the unattenuated HEMP threat environment. Intrasite cables are those that comply with length and routing restrictions specified in this standard (see 5.1.4.1). All other external cables are long-line cables and shall connect to the MCE through long-line protection modules (see 5.1.4.2). Mission-critical external cables shall be HEMP protected using special protective measures, as required.

4.3.4 Mission-critical equipment. All equipment required to perform critical time-urgent missions during and after HEMP attack shall be designated as mission-critical equipment. MCE may include such items as communications-electronics equipment, data processing subsystems,

MIL-STD-188-125-2

command/control equipment, local portions of hardened interconnects³, and critical support subsystems such as power generation/distribution and environmental control.

4.3.4.1 MCE within the electromagnetic barrier. All MCE that will operate satisfactorily and compatibly within the subsystem shields shall be installed inside an electromagnetic barrier that meets the performance requirements of this standard. No HEMP-unique performance characteristics are required in design or selection of mission-critical equipment that will be housed within a barrier.

4.3.4.2 MCE outside the electromagnetic barrier. All MCE that must be placed outside an electromagnetic barrier, including mission-critical antenna subsystems and external mission-critical cables, shall be provided with special protective measures (see 5.8.1) as required to ensure hardness in the HEMP threat environment.

4.3.5 HEMP-hardened electrical power. The system shall be provided with HEMP-hardened electrical power generation and distribution capability sufficient to perform trans- and post-attack missions, without reliance upon commercial electrical power sources.

4.3.6 Special protective measures. Special protective measures shall be implemented in cases where HEMP hardness cannot be achieved with an electromagnetic barrier alone. Additional shielding, transient suppression/attenuation devices, and equipment-level protection shall be provided as required to achieve HEMP hardness. The three categories of cases requiring special protective measures are as follows:

- a. MCE that must be located outside an electromagnetic barrier and, therefore, are not protected by the barrier (see 5.8.1),
- b. MCE that are enclosed within an electromagnetic barrier and experience mission-aborting damage or upset during verification testing, even though the barrier elements satisfy all performance requirements (see 5.8.2),
- c. Special protective volumes and barriers to provide supplementary isolation when POE protective devices cannot satisfy barrier requirements without interfering with system operation (see 5.8.3).

4.4 HEMP testing. The HEMP testing program shall demonstrate that hardness performance requirements have been satisfied and that the required HEMP hardness has been achieved. This program shall include quality assurance testing during system production and

³ Although they are not included within the scope of this document, HEMP-hardened interconnects and survivable long-haul communications circuits to other hardened systems in the network must be provided as required for mission accomplishment.

MIL-STD-188-125-2

equipment installation, acceptance testing for the electromagnetic barriers and special protective measures, and verification testing of the completed and operational system. All data acquired during the HEMP testing program shall be stored in a manner to facilitate test reporting and subsequent use of data as an HM/HS database.

4.4.1 Quality assurance program. A quality assurance program shall be implemented during system production and assembly to demonstrate that the HEMP protection materials and components comply with performance requirements of this standard. The quality assurance test procedures and results shall be documented and retained for use as baseline configuration and performance data for the HM/HS program.

4.4.2 Acceptance testing. Acceptance of the HEMP protection measures shall be based on successful demonstrations of compliance with hardness performance requirements of this standard. HEMP acceptance tests of the electromagnetic barriers and special protective measures shall be conducted after all related fabrication work has been completed. Acceptance test procedures and results shall be documented and retained for use as baseline configuration and performance data.

4.4.3 Verification testing. After completion of the HEMP protection measures and installation/operational checks of the subsystem equipment, HEMP hardness of the system shall be verified through a program of tests and supporting analysis. The verification program shall provide a definitive statement on the HEMP hardness of mission functions of the system under test. All deficiencies identified by the verification testing shall be corrected, retested, and shown to provide the required hardness. Verification test procedures and results shall be documented and retained for use as baseline configuration and performance data.

4.5 HM/HS.

4.5.1 HM/HS program development. Hardness maintenance and hardness surveillance considerations shall be included in the system planning, design, and production phases to facilitate life-cycle survivability and the development of an effective HM/HS program. The HM/HS program shall be designed to maintain the HEMP protection at a level of performance that meets the requirements in this standard.

4.5.2 HM/HS program implementation. During the verification phase, baseline data shall be obtained for the HM/HS program. The HM/HS program shall be fully implemented in the operation and support phase of the system life cycle. Effectiveness of the HM/HS program for maintaining the HEMP protection subsystem performance at the required level shall be periodically reviewed, and program revisions shall be made when required.

MIL-STD-188-125-2

5. DETAILED REQUIREMENTS

5.1 HEMP protection topology.

5.1.1 Transportable system topology. A transportable system shall consist of one or more elements (subsystems) that must be placed in separate volumes to be transportable and that must be interconnected to function together to perform the operational mission. Subsystems that are critical for performing trans- and post-HEMP attack missions shall be HEMP protected. Typical subsystems may be as follows:

- a. Mobile electric power subsystem,
- b. Power distribution subsystem,
- c. Communications equipment subsystem,
- d. Automated data processing subsystem,
- e. Command and control subsystem,
- f. Other special purpose subsystems, as defined by mission requirements.

5.1.2 Electromagnetic barrier topology. An electromagnetic barrier, consisting of a HEMP shield and POE protective devices, shall be constructed for each mission-critical subsystem of the transportable system. A typical barrier topology is shown on figure 1. The HEMP shields and POE protective devices shall be configured to accomplish the following technical requirements:

- a. To enclose all MCE, except equipment that will not function properly if placed within the protected volume,
- b. To comply with the shield and POE performance requirements specified in this standard,
- c. To minimize the number of POEs,
- d. To minimize requirements for special protective measures,
- e. To facilitate HEMP acceptance and verification testing,

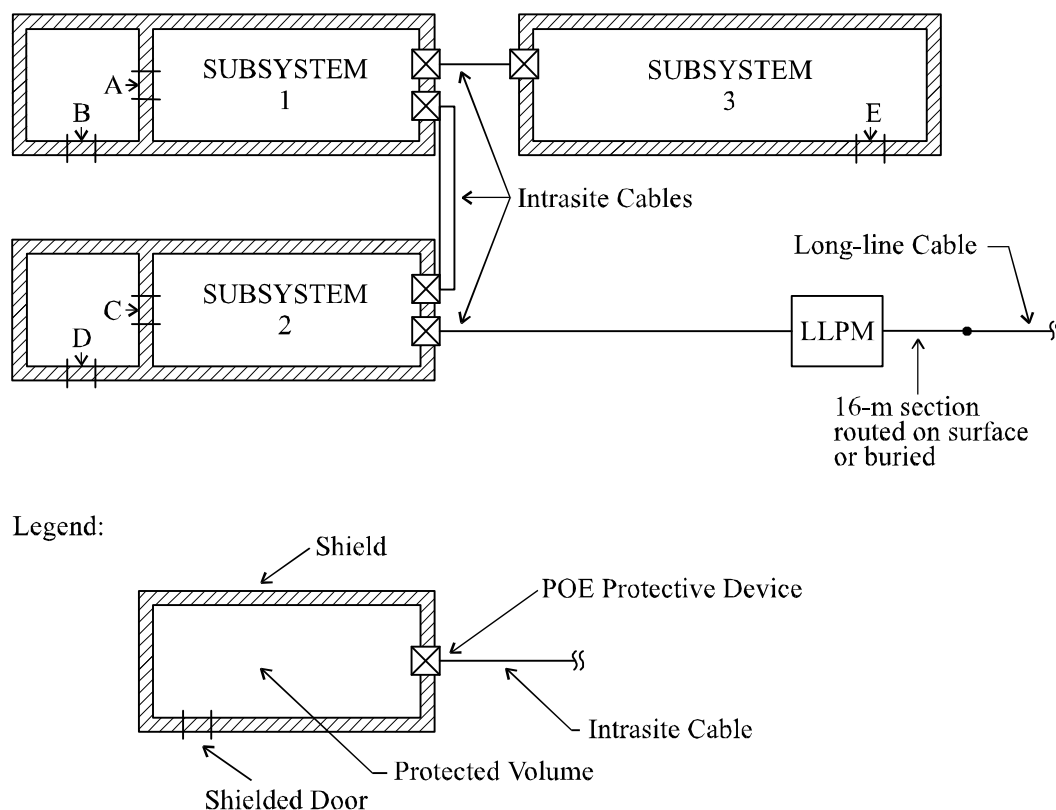
MIL-STD-188-125-2

Note: Shielded doors (A-E) located as far as practical from the penetration entry area.

FIGURE 1. Typical transportable system barrier topology.

- f. To minimize requirements for scheduled hardness maintenance and surveillance.

5.1.3 Penetration entry area. As a design objective, there should be a single penetration entry area on the electromagnetic barrier of each HEMP-protected subsystem for all piping and electrical (including fiber optic waveguide-below-cutoff) POEs, except roof-mounted antenna line POEs. The penetration entry area shall be located as far as practical from normal and emergency personnel entries/exits, equipment accesses, and ventilation POEs. In addition, the penetration entry area shall be located either on the floor shield surface of an elevated subsystem or as close as practical to the ground on a wall shield surface to minimize the length of vertical cable run (figure 2). Radio frequency (RF) antenna line POEs for roof-mounted antennas shall penetrate the barrier as close as practical to the mounting point.

MIL-STD-188-125-2

FIGURE 2. Penetration entry area placement.

5.1.4 External electrical cabling. Each electrical cable outside the subsystem electromagnetic barriers shall be designated as an intrasite cable or long-line cable, based upon length and routing configuration. This designation determines the requirement to provide a long-line protection module and the PCI performance and test requirements (see 5.7).

Additionally, each external electrical cable shall be designated as mission-critical or noncritical. Mission-critical external cables shall be protected with special protective measures as required to achieve HEMP hardness (see 5.8).

5.1.4.1 Intrasite cabling. Intrasite cables are part of the transportable system and are used to interconnect the subsystems and to connect the subsystems to mission-critical and noncritical equipment outside the subsystem electromagnetic barriers. An intrasite cable shall not exceed 200 m (656 ft) in length and shall comply with the following routing restrictions (figure 3a):

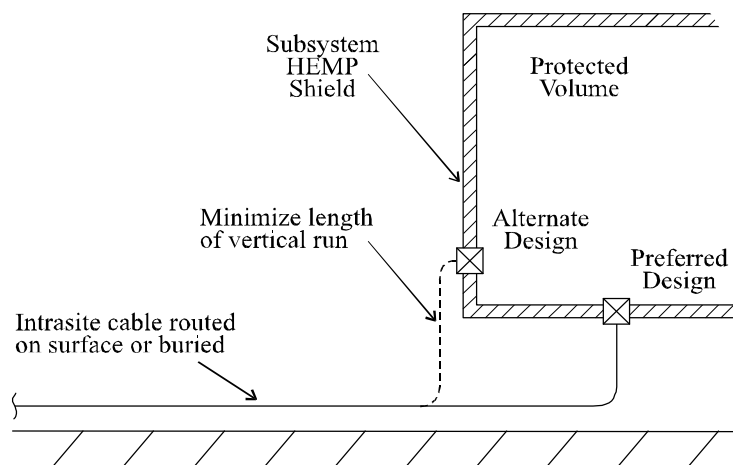
- a. Except for elevated sections permitted under subparagraph b below, the intrasite cable shall be routed on the ground, within 10 cm (4 in) of the surface, or shall be buried.
- b. The total area of all elevated sections, where the cable height above ground exceeds 10 cm, shall not exceed 30 m² (323 ft²). The maximum height at any point on an elevated cable section shall not exceed 7 m (23 ft).
- c. The intrasite cable shall not connect to equipment or structures, including antennas in the case of an RF antenna line, with heights exceeding 7 m.

MIL-STD-188-125-2

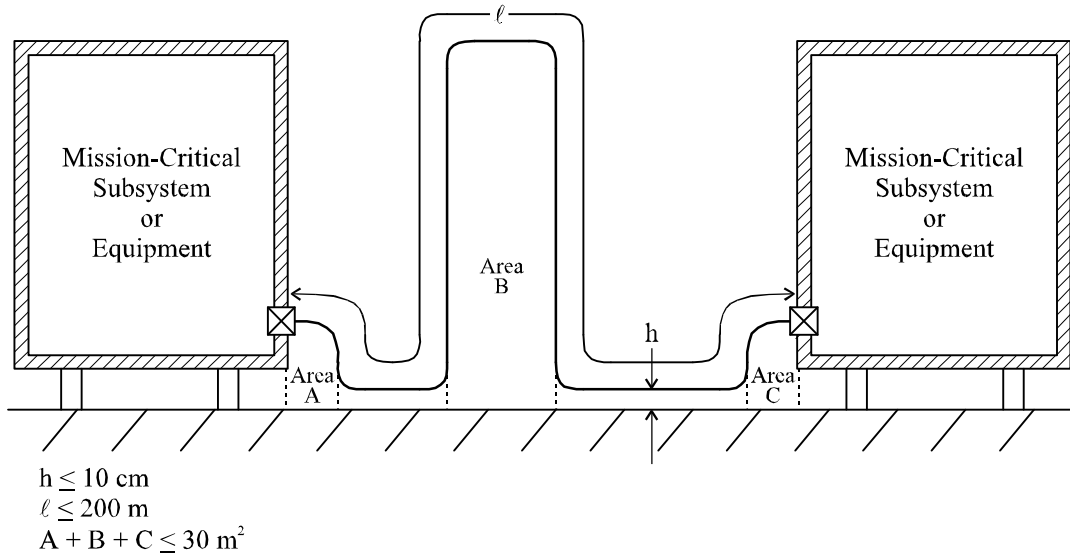

a. Intrasite cable.

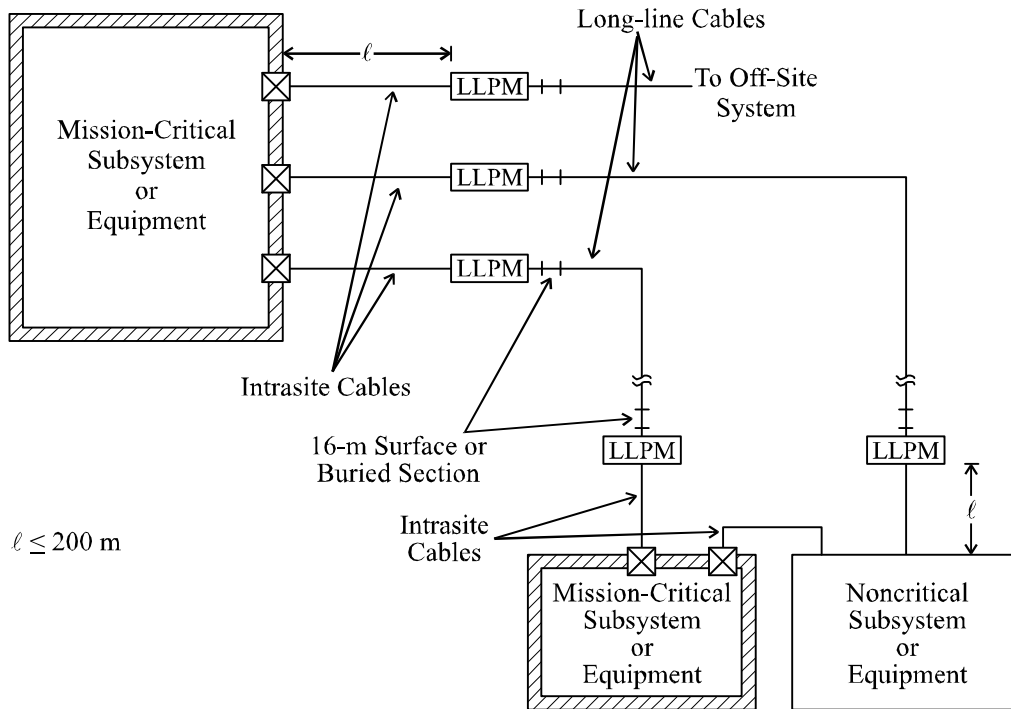

b. Long-line cables.

FIGURE 3. External cable descriptions.

MIL-STD-188-125-2

The length and routing restrictions apply to a single intrasite cable, whether shielded or unshielded. In the case of an external cable that branches between the end points, the restrictions apply to the sums of the lengths and areas on all branches.

5.1.4.2 Long-line cabling. Long-line cables include commercial power, telephone, communications, and other electrical conductors that extend beyond the transportable system deployment site. Segments of subsystem and equipment interconnecting cables that do not comply with the length and routing restrictions for intrasite cables shall also be designated as long-line cables (figure 3b). The number of long-line cables connected to the system shall be minimized. As a design objective, the system should be capable of performing the trans- and post-HEMP attack missions when disconnected from all long-line cables.

LLPMs shall be provided, except on long RF antenna lines, to isolate the intrasite cable plant and the mission-critical subsystems and equipment from transients that can be induced on the long-lines by the HEMP threat environment (see 5.7.2). An LLPM may be connected to multiple long-line cables or multiple intrasite cables, and several LLPMs may be combined into a single assembly.

Commercial power lines, commercial telephone lines, and other long-line electrical conductors that extend beyond the deployment site shall be designed to be readily disconnectable. As a design objective, long-line segments of interconnecting cables should also be designed to be disconnectable. The ability to disconnect a long-line shall not be used as a substitute for the LLPM requirement.

5.2 Transportable system grounding.

5.2.1 Equipotential ground plane. Each subsystem shield shall be grounded by the equipotential ground plane method IAW guidance in MIL-HDBK-419. The subsystem HEMP shields shall be employed as the equipotential ground planes.

5.2.2 Grounding to the subsystem HEMP shields. Grounds for equipment and structures enclosed within protected volumes shall be electrically bonded to the inside surface of a shield by the shortest practical path. Grounds for equipment and structures outside the electromagnetic barriers shall be electrically bonded to the outside surface of a shield or to the earth electrode subsystem. Ground cables used to connect subsystem shields (equipotential ground planes) to the earth electrode subsystem shall be electrically bonded to the outside surface of a shield, and at least one such ground cable shall be located at each penetration entry area. All grounding connections to the subsystem HEMP shields shall be made in a manner that does not create POEs.

MIL-STD-188-125-2

5.2.3 Long-line protection module grounding. Grounding shall be provided at each LLPM. The LLPM ground shall be sufficient for proper operation of the protection module.

5.3 Subsystem HEMP shields.

5.3.1 Shielding effectiveness. Each subsystem HEMP shield, with all POE protective devices installed, shall provide at least the minimum shielding effectiveness shown on figure 4.

5.3.2 Shield configuration. Each subsystem HEMP shield, exclusive of its POEs, shall be a continuous conductive enclosure, normally constructed of a metal such as steel, copper, or aluminum. The enclosure shall be electromagnetically closed at all seams and joints between adjacent panels on all wall, ceiling, and floor surfaces.

5.3.3 Shield production quality assurance. In-progress inspection or testing of subsystem HEMP shield seams and joints, including those used for installation of POE protective devices, should proceed continuously in parallel with the shield fabrication and assembly activity.

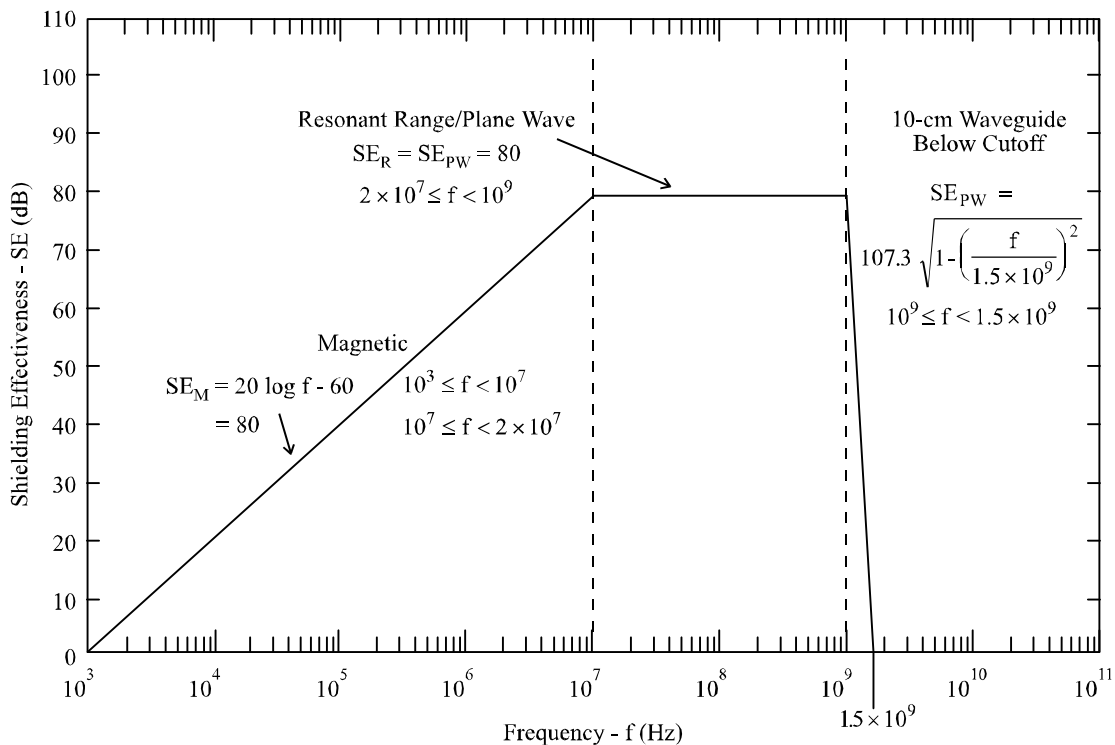

FIGURE 4. Minimum HEMP shielding effectiveness requirements (measured in accordance with procedures of Appendix A).

MIL-STD-188-125-2

5.3.4 Shield acceptance testing. After completion of each subsystem HEMP shield and installation of the POE protective devices, but before installation of MCE, the shield acceptance test shall be conducted to determine if the shield performs IAW minimum requirements shown on figure 4. The test shall be conducted using shielding effectiveness test procedures of Appendix A. All defects found during the acceptance testing shall be corrected, retested, and shown to provide the required performance.

5.3.4.1 Subsystem shield modifications. If POEs are added or the subsystem HEMP shield is breached and repaired after acceptance testing, shield acceptance testing in the affected area shall be repeated.

5.4 Architectural POEs.

5.4.1 HEMP protection for architectural POEs. Architectural POEs include personnel entryways and exits and equipment access doors and panels through a subsystem HEMP shield. HEMP protection for all architectural POEs shall be provided with electromagnetic closure techniques, such as shielded doors and welded or RF gasketed metal access covers.

5.4.2 Personnel entryways and exits. HEMP protection for personnel entryways and exits shall be provided with shielded doors or with two-door shielded vestibules (figure 5). Wiring in the protected volumes (equipment side of a single door or inner vestibule door) shall be routed as far as practical from the door seals.

5.4.2.1 Shielded doors. When installed and closed, shielded doors shall provide at least the minimum shielding effectiveness shown on figure 4. A weather enclosure, environmental gasket, or other appropriate treatment shall be provided on exterior doors to protect the RF seals from corrosion and exposure to blown dust and other natural elements.

5.4.2.2 Shielded vestibules. When a shielded vestibule is used to achieve more reliable performance, the vestibule shield shall comply with the same requirements that apply to the subsystem HEMP shields. All vestibule POE protective devices, either into the subsystem protected volume or to the outside, shall comply with the same requirements that apply to other POE protective devices through the electromagnetic barrier (see 5.5. through 5.7). As design objectives, vestibule shielded doors should be at 90 degrees to each other and they should be provided with interlocks or alarms to ensure that at least one of the doors remains closed at all times except during emergency evacuations.

5.4.3 Equipment accesses. Separate equipment access POEs through the subsystem HEMP shields shall be provided only when movement of the equipment through a personnel entryway is not practical. HEMP protection for equipment access POEs shall be provided with a metal cover

MIL-STD-188-125-2

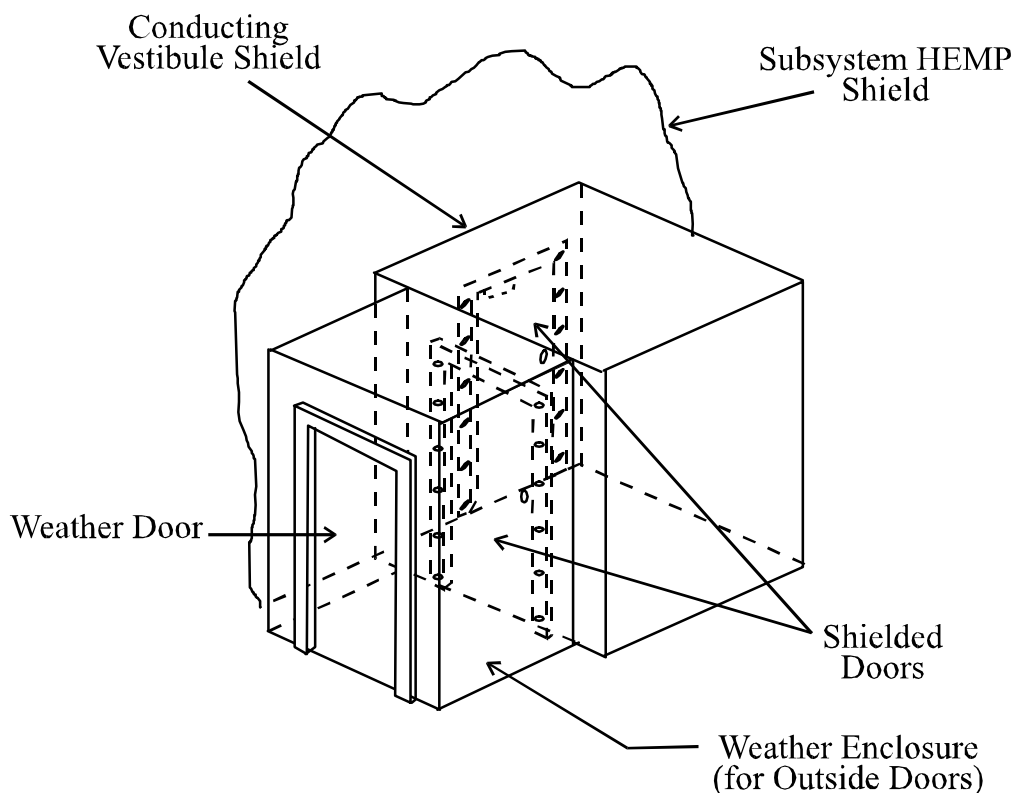
FIGURE 5. Typical vestibule entryway.

and an RF seal between the cover and the shield. When closed, the equipment access covers shall provide at least the minimum shielding effectiveness shown on figure 4. A weather vestibule, environmental gasket, or other appropriate treatment shall be provided to protect the RF seals from corrosion and exposure to blown dust and other natural elements.

5.4.4 Acceptance testing for architectural POE protective measures. Acceptance testing of shielded doors, vestibule shields, and vestibule aperture POE protective devices shall be conducted using the shielding effectiveness test procedures of Appendix A. Acceptance testing of vestibule electrical POE protective devices shall be conducted using the PCI test procedures of Appendix B. All defects found during the acceptance testing shall be corrected, retested, and shown to provide the required performance.

MIL-STD-188-125-2

5.5 Mechanical POEs.

5.5.1 HEMP protection for mechanical POEs. HEMP protection for mechanical POEs, including piping and ventilation penetrations through a subsystem HEMP shield, shall be provided with waveguide-below-cutoff techniques. As design objectives, the number of piping POEs should be constrained to no more than five per HEMP-protected subsystem and the number of ventilation POEs should be limited to no more than three per HEMP-protected subsystem.

5.5.2 Piping POEs. Piping shall penetrate a subsystem HEMP shield as metallic pipe sections that are configured as single waveguides below cutoff or WBC arrays (figure 6). Dielectric hoses or pipes shall be converted to metal piping before penetrating a subsystem HEMP shield. The presence of the protected piping POEs shall not degrade the shielding effectiveness of the subsystem HEMP shield below the minimum requirements shown on figure 4.

The inside diameter of a single piping POE WBC and the transverse cell dimensions of each of the cells in a piping POE WBC array shall be limited such that the cutoff frequency is at least 1.5 GHz. The length of the waveguide section shall be sufficient to provide at least 80 dB of attenuation at 1 GHz. No dielectric (glass, plastic, etc.) pipe lining shall be permitted in the waveguide section. External and internal piping shall be connected at ends of the waveguide section; no HEMP-unique requirements apply to these couplings. If a piping POE protection device cannot be designed to satisfy these restrictions without interfering with the fluid flow requirements, a special protective volume shall be established (see 5.8.3.1).

5.5.3 Ventilation POEs. Ventilation ducts shall penetrate a subsystem HEMP shield as sections of metallic ducting that are configured as waveguide-below-cutoff arrays (figure 7). The presence of the protected ventilation POEs shall not degrade the shielding effectiveness of the subsystem HEMP shield below the minimum requirements shown on figure 4.

The transverse cell dimensions of each of the cells in a ventilation POE WBC array shall be limited such that the cutoff frequency is at least 1.5 GHz. The length of the waveguide section shall be sufficient to provide at least 80 dB of attenuation at 1 GHz. No conductors shall be permitted to penetrate through the waveguide cells.

MIL-STD-188-125-2

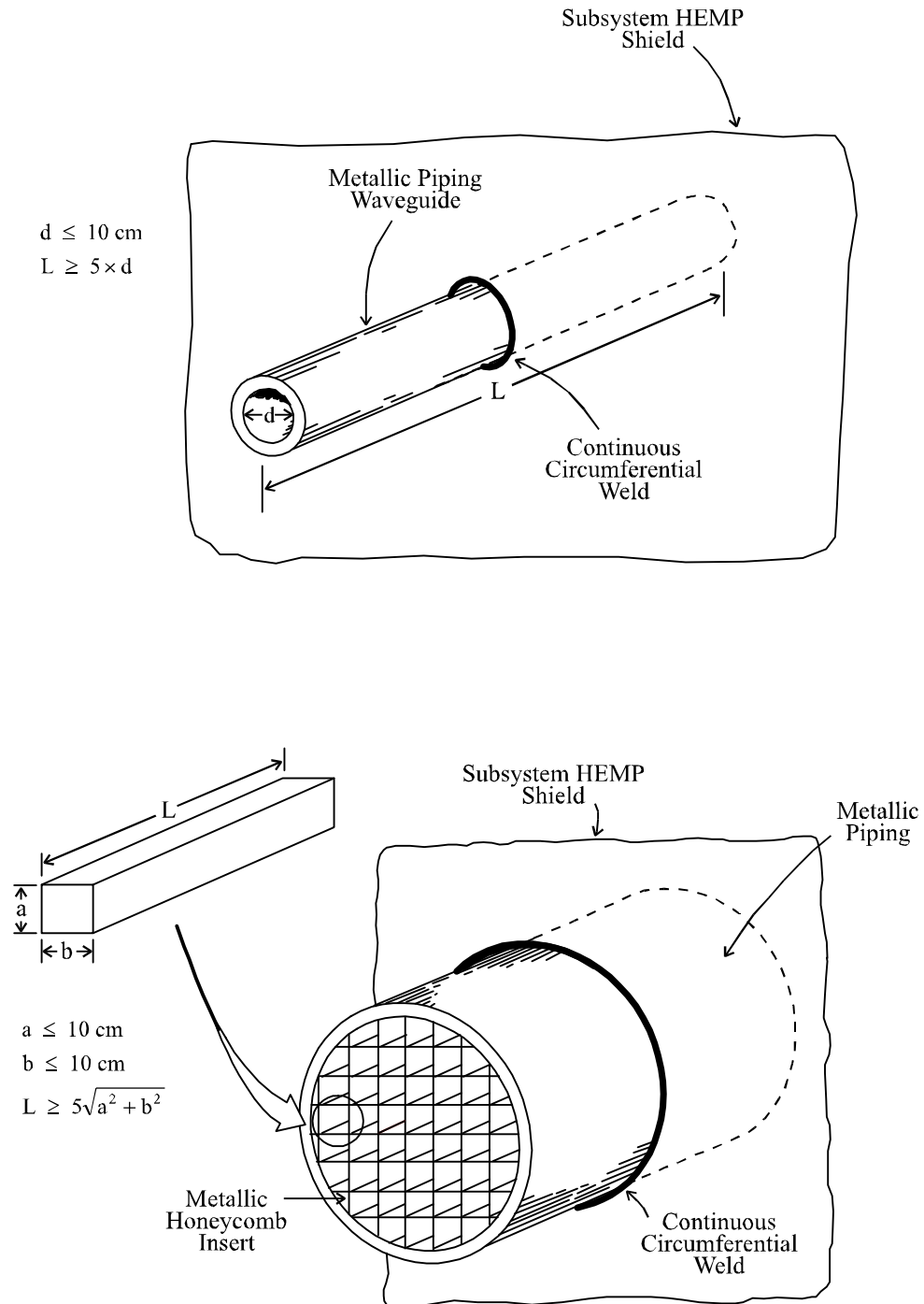

FIGURE 6. Typical waveguide-below-cutoff piping POE protective devices.

MIL-STD-188-125-2

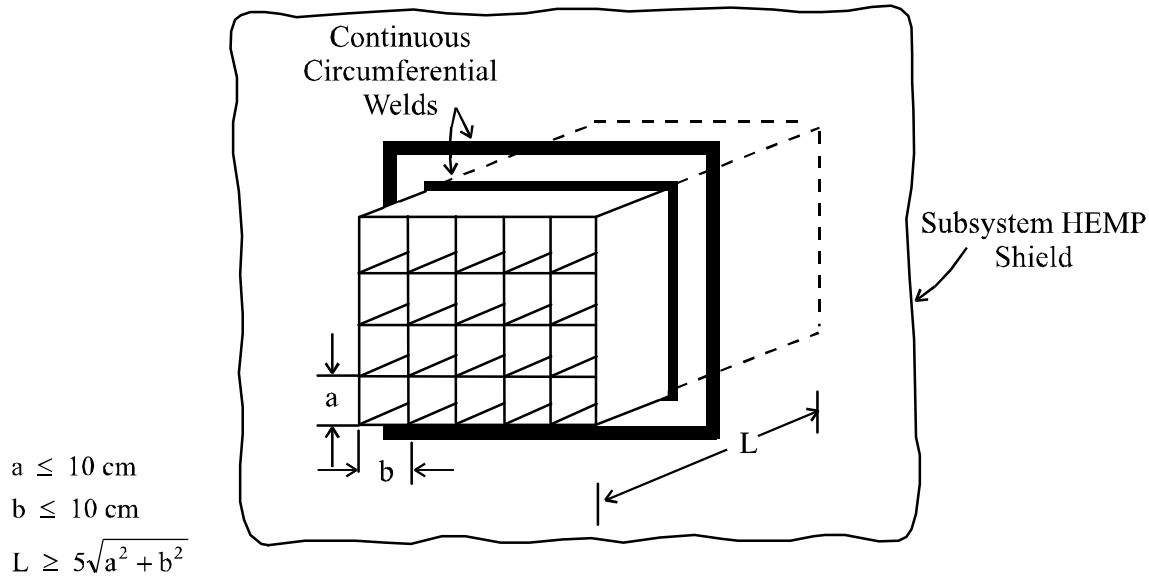

FIGURE 7. Typical waveguide-below-cutoff array ventilation POE protective device.

5.5.4 Acceptance testing for mechanical POE protective devices. Acceptance testing for mechanical POE protective devices, including those for piping and ventilation penetrations, shall be conducted using the shielding effectiveness test procedures of Appendix A. All defects found during the acceptance testing shall be corrected, retested, and shown to provide the required performance.

5.6 Structural POEs.

5.6.1 HEMP protection for structural POEs. HEMP protection for structural POEs, including beams, columns, and other metallic structural elements that must penetrate through a subsystem HEMP shield, shall be provided with continuous electromagnetic closure between the penetrating element and the subsystem shield. As a design objective, the subsystem should be designed to minimize the number of metallic structural elements required to penetrate the shield. Nonmetallic structural elements shall not penetrate a subsystem HEMP shield. The presence of protected structural POEs shall not degrade the shielding effectiveness of the subsystem HEMP shield below the minimum requirements shown on figure 4.

5.6.2 Acceptance testing for structural POE treatments. Acceptance testing for structural POE protective treatments shall be conducted using the shielding effectiveness test procedures of

MIL-STD-188-125-2

Appendix A. All defects found during the acceptance testing shall be corrected, retested, and shown to provide the required performance.

5.7 Electrical POEs and long-line protection modules.

5.7.1 Electrical POEs.

5.7.1.1 HEMP protection for electrical POEs. HEMP protection for electrical POEs, including all intrasite power, communications, signal, control, and data conductors that penetrate through a subsystem HEMP shield, whether shielded or unshielded, shall be provided with transient suppression/attenuation devices or optoelectronic isolation techniques. The number of electrical POEs shall be limited to the minimum required for operational, life-safety, and habitability purposes. The presence of the protected electrical POEs shall not degrade the shielding effectiveness of the subsystem HEMP shield below the minimum requirements shown on figure 4.

Electrical POE transient suppression/attenuation devices (figure 8) shall consist of linear and nonlinear elements, as required to satisfy the performance requirements. When prescribed pulses (see table I) are injected at the external terminal of the POE protective device, the norms of the residual internal response stresses at the internal terminal shall not exceed the maximums (see table II) for the applicable class of electrical POE⁴. Additionally, the protective device shall be designed to withstand a sufficient number of test pulses at the prescribed current without damage or unacceptable performance degradation to accommodate life-cycle testing.

All-dielectric fiber optic cables shall be used for intrasite transmission of control, signal, and data information and for penetration of subsystem HEMP shields, wherever practical. HEMP protection for the fiber optic cable POE shall be provided with a WBC. The inside diameter of a fiber optic WBC shall be limited such that the waveguide cutoff frequency is at least 1.5 GHz. The length of the waveguide shall be sufficient to provide at least 80 dB attenuation at 1 GHz. No conductors or conducting fluids shall be permitted to pass through the waveguide; the WBC protective device shall be filled or its ends shall be capped to prevent inadvertent insertion of conductors.

5.7.1.2 Intrasite power line POE protective device requirements. A Norton source with a 500-A short-circuit current, ≤ 20 -ns risetime and 500-550-ns full-width at half-maximum amplitude (FWHM), and ≥ 60 - Ω source impedance, connected to the external terminal of the

⁴ Detailed PCI requirements for electrical POEs, including common mode test requirements, waveforms for the injected pulses, circuit test configuration information, and additional constraints on the residual response stress, are contained in tables I and II and in the PCI test procedures of Appendix B.

MIL-STD-188-125-2

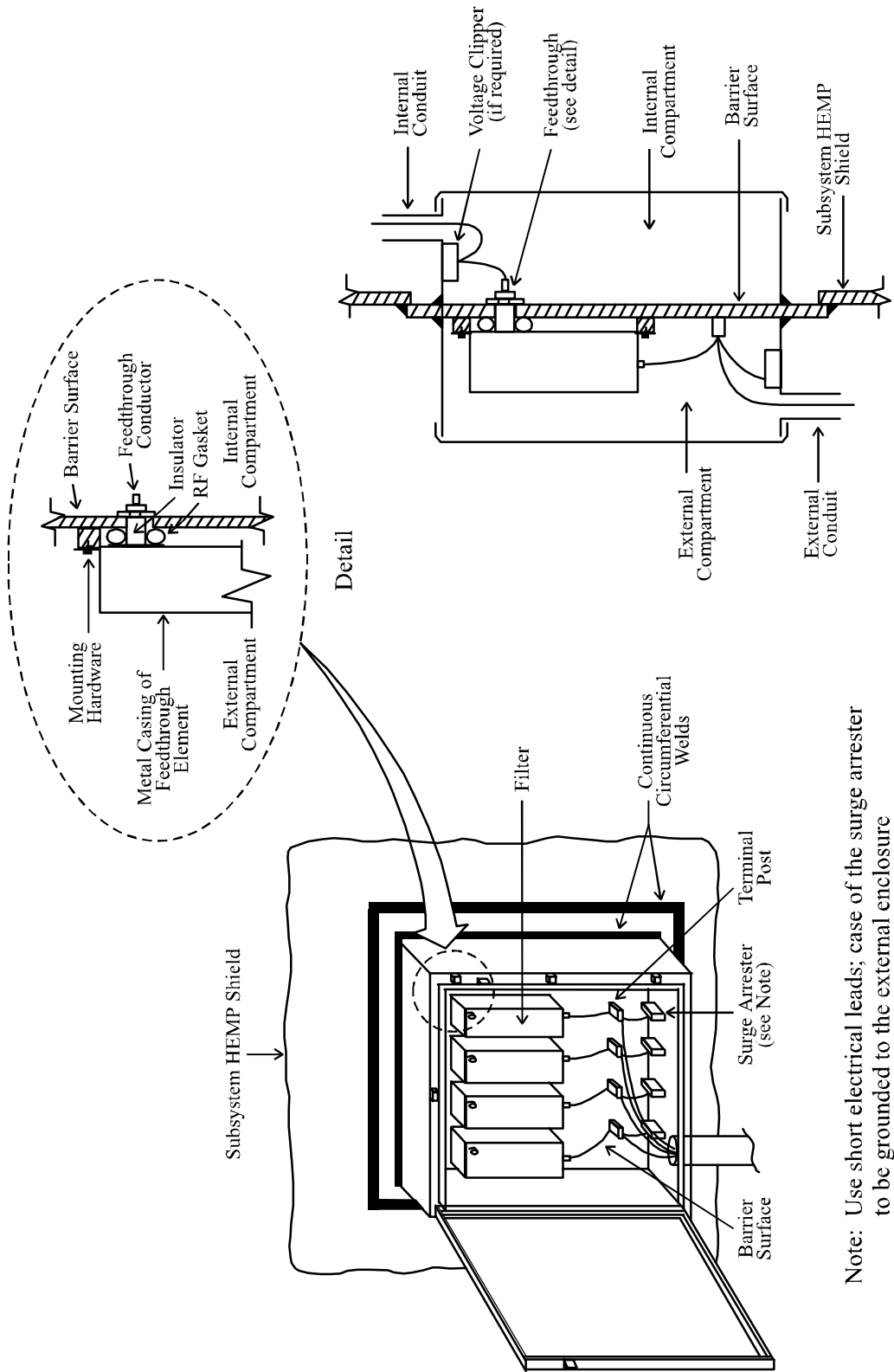

Note: Use short electrical leads; case of the surge arrester to be grounded to the external enclosure

FIGURE 8. Typical electrical POE protective device.

MIL-STD-188-125-2

TABLE I. Norton source parameters, waveforms, and acceptance test loads for electrical POE injection specifications.

a. Electrical POEs, except RF antenna line POEs.

Class of Electrical POE/ Type of Injection ¹	Peak Short- Circuit Current (A)	Source Impedance (ohms)	Risetime (s)	FWHM (s)	Acceptance Test Resistance (ohms)
Intrasite power line POEs					
Short pulse common mode ²	1,000	≥ 60	$\leq 2 \times 10^{-8}$	$5 \times 10^{-7} - 5.5 \times 10^{-7}$	Not applicable
Short pulse wire-to-ground ³	500	≥ 60	$\leq 2 \times 10^{-8}$	$5 \times 10^{-7} - 5.5 \times 10^{-7}$	⁴ 2 or $V_{\text{rated}}/I_{\text{rated}}$
Intermediate pulse common mode ^{2,5}	250	≥ 10	$\leq 1.5 \times 10^{-6}$	$3 \times 10^{-3} - 5 \times 10^{-3}$	Not applicable
Intermediate pulse wire-to-ground ^{3,5}	250	≥ 10	$\leq 1.5 \times 10^{-6}$	$3 \times 10^{-3} - 5 \times 10^{-3}$	50
Intrasite control/signal/data line POEs					
Short pulse common mode ²	1,000	≥ 60	$\leq 2 \times 10^{-8}$	$5 \times 10^{-7} - 5.5 \times 10^{-7}$	Not applicable
Short pulse wire-to-ground ³	⁶ $1,000/\sqrt{N}$ or 100	≥ 60	$\leq 2 \times 10^{-8}$	$5 \times 10^{-7} - 5.5 \times 10^{-7}$	⁴ 2 or $V_{\text{rated}}/I_{\text{rated}}$
Intermediate pulse common mode ^{2,5}	250	≥ 10	$\leq 1.5 \times 10^{-6}$	$3 \times 10^{-3} - 5 \times 10^{-3}$	Not applicable
Intermediate pulse wire-to-ground ^{3,5,7}	250	≥ 10	$\leq 1.5 \times 10^{-6}$	$3 \times 10^{-3} - 5 \times 10^{-3}$	50

MIL-STD-188-125-2

TABLE I. Norton source parameters, waveforms, and acceptance test loads for electrical POE injection specifications - Continued.

b. RF antenna line POEs.

Class of Electrical POE/ Type of Injection ¹	Dominant Response Frequency (MHz)	Peak Short- Circuit Current (A)	Source Impedance (ohms)	Risetime (s)	FWHM (s)	Acceptance Test Resistance (ohms)
RF antenna line shield conductors						
Buried ⁸						
Short pulse shield-to-ground ⁹	Not Applicable	800	≥ 60	$\leq 2 \times 10^{-8}$	5×10^{-7} - 5.5×10^{-7}	$10 Z_T$
Nonburied intrasite ⁸						
Short pulse shield-to-ground ⁹	Not Applicable	1,000	≥ 60	$\leq 2 \times 10^{-8}$	5×10^{-7} - 5.5×10^{-7}	$10 Z_T$
Nonburied long line ⁸						
Short pulse shield-to-ground ⁹	Not Applicable	5,000	≥ 60	$\leq 2 \times 10^{-8}$	5×10^{-7} - 5.5×10^{-7}	$10 Z_T$
RF antenna line core conductors						
Short pulse core wire-to-shield	$^{11} \leq 30$	Threat level ¹¹	≥ 60	$\leq 2 \times 10^{-8}$	5×10^{-7} - 5.5×10^{-7}	$10 Z_T$
Short pulse core wire-to-to-shield	$^{11} > 30$	Threat level ^{11,12}	≥ 50	$\leq 5 \times 10^{-9}$	Variable ¹¹	$10 Z_T$

MIL-STD-188-125-2

TABLE I. Norton source parameters, waveforms, and acceptance test loads for electrical POE injection specifications - Continued.

c. Notes.

- ¹ Pulsed current injection specifications are defined in terms of the Norton equivalent sources. Double-exponential waveforms are used in all POE PCI specifications, except for RF antenna line core wire-to-shield specifications at dominant response frequencies > 30 MHz and peak short-circuit currents within the capability of the charge line pulser. For these exceptions, the core wire-to-shield injection specification uses the output waveform of the charge line pulser, with the length of the charge line equal to the quarter-wavelength at the applicable dominant response frequency. Peak short-circuit current is the peak time-domain current into a short-circuit calibration load at the pulser output terminals. Source impedance is the pulser peak time-domain open-circuit voltage divided by the peak time-domain short-circuit current. Risettime is the 10-percent to 90-percent risetime. Full-width at half-maximum amplitude (FWHM) is the time interval between the 50-percent amplitude points.
- ² The source parameters are generally specified by the minimum acceptable source impedance and the maximum acceptable risetime. This is done for the sole purpose of experimental practicality, so that the current injection sources are not required to precisely match prescribed waveforms.
- ³ For a common mode test, all conductors in the cable are simultaneously driven with respect to ground, where ground is a point on the subsystem HEMP shield in the vicinity of the POE protective device under test. Common mode testing is required for verification, but is not required for acceptance.
- ³ For a wire-to-ground test, each of the conductors in the cable is individually driven with respect to ground, where ground is a point on the subsystem HEMP shield in the vicinity of the POE protective device under test.
- ⁴ V_{rated} and I_{rated} are the maximum voltage and current ratings of the POE protective device, respectively. The smaller of these two resistances is required.

MIL-STD-188-125-2

TABLE I. Norton source parameters, waveforms, and acceptance test loads for electrical POE injection specifications - Continued.

c. Notes (continued).

- ⁵ Intermediate pulse current injection tests are required only on those intrasite electrical POE protective devices that may sometimes be connected to an LLP. If the associated LLP is available for testing, the intermediate pulse current shall be injected at the long-line terminal of the LLP. The current shall be injected at the external terminal of the POE protective device when the LLP cannot be provided for testing.
- ⁶ N is the number of conductors in the cable. The larger of these two amplitudes is required.
- ⁷ Intermediate pulse wire-to-ground tests of control/signal/data line POEs are required for acceptance, but they are not required for verification.
- ⁸ An antenna shield is considered buried when it terminates at a buried antenna and < 1 m (3.3 ft) of its total length is not covered by earth or concrete. If either of these conditions is not satisfied, the antenna shield is considered nonburied.
- ⁹ For a shield-to-ground test, maximum feasible length of the antenna line shield is driven with respect to ground, where ground is a point on the subsystem HEMP shield in the vicinity of the POE protective device under test.
- ¹⁰ The core conductor is terminated to the cable shield in a dummy load with resistance equal to the characteristic impedance of the interior RF transmission line. The shield is electrically terminated in a short circuit to the installed equipment or to the subsystem HEMP shield.
- ¹¹ The dominant response frequency (or frequencies) and threat-level peak short-circuit current are determined from extrapolated coupling measurements (see Appendix B).
- ¹² If the PCI short-circuit current requirement exceeds the capability of the charge line pulser, the short pulse double-exponential pulser shall be used instead of the charge line pulser.

MIL-STD-188-125-2

TABLE II. Maximum allowable residual internal response norms for electrical POE injection specifications.

a. Electrical POEs, except RF antenna line POEs.

Class of Electrical POE/ Type of Injection	Type of Measurement	Peak Current (A)	Peak Rate of Rise (A/s)	Root Action (A \sqrt{s})
Intrasite power line POEs				
Short pulse common mode	Bulk current	≤ 10	$\leq 1 \times 10^7$	$\leq 1.6 \times 10^{-1}$
Short pulse wire-to-ground	Wire current	≤ 10	$\leq 1 \times 10^7$	$\leq 1.6 \times 10^{-1}$
Intermediate pulse common mode	Bulk current		No damage or performance degradation ¹	
Intermediate pulse wire-to-ground	Wire current		No damage or performance degradation ¹	
Intrasite control/signal/data line POEs				
Low-voltage lines ²				
Short pulse common mode	Bulk current	≤ 0.1	$\leq 1 \times 10^7$	$\leq 1.6 \times 10^{-3}$
Short pulse wire-to-ground	Wire current	≤ 0.1	$\leq 1 \times 10^7$	$\leq 1.61 \times 10^{-3}$
Intermediate pulse common mode	Bulk current		No damage or performance degradation ¹	
Intermediate pulse wire-to-ground	Wire current		No damage or performance degradation ¹	
High-voltage lines ²				
Short pulse common mode	Bulk current	≤ 1.0	$\leq 1 \times 10^7$	$\leq 1.6 \times 10^{-2}$
Short pulse wire-to-ground	Wire current	≤ 1.0	$\leq 1 \times 10^7$	$\leq 1.6 \times 10^{-2}$
Intermediate pulse common mode	Bulk current		No damage or performance degradation ¹	
Intermediate pulse wire-to-ground	Wire current		No damage or performance degradation ¹	

MIL-STD-188-125-2

TABLE II. Maximum allowable residual internal response norms for electrical POE injection specifications - Continued.

b. RF antenna line POEs.

Class of Electrical POE/ Type of Injection	Type of Measurement	Peak Current (A)	Peak Rate of Rise (A/s)	Root Action (A \cdot \sqrt{s})
RF antenna line POEs				
Shield conductors				
Short pulse shield-to-ground	Shield current	≤ 0.1	$\leq 1 \times 10^7$	$\leq 1.6 \times 10^{-3}$
Short pulse core wire-to-shield	Shield current	≤ 0.1	$\leq 1 \times 10^7$	$\leq 1.6 \times 10^{-3}$
Core conductors (receive only)				
Short pulse shield-to-ground	Wire current	≤ 0.1	No damage or performance degradation ¹	No damage or performance degradation ¹
Short pulse core wire-to-shield	Wire current	≤ 0.1	No damage or performance degradation ¹	No damage or performance degradation ¹
Core conductors (transmit or transceive)				
Short pulse shield-to-ground	Wire current	≤ 1.0	No damage or performance degradation ¹	No damage or performance degradation ¹
Short pulse core wire-to-shield	Wire current	≤ 1.0	No damage or performance degradation ¹	No damage or performance degradation ¹

MIL-STD-188-125-2

TABLE II. Maximum allowable residual internal response norms for electrical POE injection specifications - Continued.

c. Notes.

- ¹ Pass/fail criteria on the residual internal response norms are not specified for the intermediate pulse current injection test sequence. Pass/fail criteria on the residual internal response peak rate of rise and root action norms on RF antenna line core conductors are not specified for the short pulse shield-to-ground and core wire-to-shield current injection test sequences. The pass/fail criteria of no POE protective device damage or performance degradation also applies to PCI test sequences where this note does not appear in the table.
- ² Low-voltage control/signal/data lines are those with maximum operating voltage < 90 V. High-voltage lines are those with a maximum operating voltage ≥ 90 V.

MIL-STD-188-125-2

POE protective device on a penetrating power line conductor, shall produce a residual internal response stress no greater than 10 A and shall not cause device damage or performance degradation⁴.

A Norton source with a 250-A short-circuit current, $\leq 1.5\text{-}\mu\text{s}$ risetime and 3-5-ms FWHM, and $\geq 10\text{-}\Omega$ source impedance, connected to a penetrating power line conductor that may sometimes interface to an LLPM, shall not cause device damage or performance degradation⁴. If the associated LLPM is available for testing, the intermediate pulse current shall be injected at the long-line terminal of the LLPM. Only the cable to the POE protective device under test shall be connected at the LLPM intrasite terminals during the injection, even if the LLPM normally connects to more than one subsystem or equipment. The current shall be injected at the external terminal of the POE protective device under test, if the LLPM cannot be provided for testing.

If a POE protective device cannot be designed to satisfy the residual internal stress limits or functional requirements without interfering with operational signals that it is required to pass, a special protective volume shall be established (see 5.8.3.2).

5.7.1.3 Intrasite control, signal, and data line POE protective device requirements. A Norton source with a $1,000/\sqrt{N}$ or 100-A short-circuit current (where N is the number of conductors in the cable, and the larger amplitude is chosen), $\leq 20\text{-ns}$ risetime and 500-550-ns FWHM, and $\geq 60\text{-}\Omega$ source impedance, connected to the external terminal of the POE protective device on a penetrating low-voltage control/signal/data line conductor, shall produce a residual internal response stress no greater than 0.1 A and shall not cause device damage or performance degradation⁴. A Norton source with a $1,000/\sqrt{N}$ or 100-A short-circuit current (where N is the number of conductors in the cable, and the larger amplitude is chosen), $\leq 20\text{-ns}$ risetime and 500-550-ns FWHM, and $\geq 60\text{-}\Omega$ source impedance, connected to the external terminal of the POE protective device on a penetrating high-voltage control/signal/data line conductor, shall produce a residual internal response stress no greater than 1.0 A and shall not cause device damage or performance degradation⁴. Low-voltage control/signal/data lines are those with maximum operating voltage $< 90\text{ V}$; high-voltage lines are those with a maximum operating voltage $\geq 90\text{ V}$.

A Norton source with a 250-A short-circuit current, $\leq 1.5\text{-}\mu\text{s}$ risetime and 3-5-ms FWHM, and $\geq 10\text{-}\Omega$ source impedance, connected to a penetrating control/signal/data line conductor that may sometimes interface to an LLPM, shall not cause device damage or performance degradation⁴. If the associated LLPM is available for testing, the intermediate pulse current shall be injected at the long-line terminal of the LLPM. Only the cable to the POE protective device under test shall be connected at the LLPM intrasite terminals during the injection, even if the LLPM normally connects to more than one subsystem or equipment. The current shall be injected

MIL-STD-188-125-2

at the external terminal of the POE protective device under test, if the LLPM cannot be provided for testing.

If a POE protective device cannot be designed to satisfy the residual internal stress limits or functional requirements without interfering with operational signals that it is required to pass, a special protective volume shall be established (see 5.8.3.2).

5.7.1.4 Antenna line POE protective device requirements.

5.7.1.4.1 Core conductor injection requirements for receive-only antenna line POE protective devices. A pulse of the prescribed waveform and amplitude, occurring on the signal-carrying core conductor at the antenna terminals of a receive-only antenna subsystem, shall produce residual internal response stresses no greater than 0.1 A on the core conductor and shield and shall not cause POE protective device damage or performance degradation⁴. An antenna protective device may be used in conjunction with the POE protective device to achieve the required transient suppression/attenuation. The waveform and amplitude of the pulses to be applied shall be determined by threat extrapolation of coupling measurements. Coupling measurements shall be acquired under electromagnetic field excitation provided by CW immersion, threat-level illumination, or another threat-relatable method. Coupling and PCI test details are provided in Appendix B.

If the antenna subsystem HEMP protection cannot be designed to satisfy the residual internal stress limits or functional requirements without interfering with operational signals that it is required to pass, a special protective volume shall be established (see 5.8.3.2).

5.7.1.4.2 Core conductor injection requirements for transmit antenna line POE protective devices. A pulse of the prescribed waveform and amplitude, occurring on the signal-carrying core conductor at the antenna terminals of a transmit or transceive antenna subsystem, shall produce residual internal response stresses no greater than 1.0 A on the core conductor and no greater than 0.1 A on the shield and shall not cause POE protective device damage or performance degradation⁴. An antenna protective device may be used in conjunction with the POE protective device to achieve the required transient suppression/attenuation. The waveform and amplitude of the pulses to be applied shall be determined by threat extrapolation of coupling measurements. Coupling measurements shall be acquired under electromagnetic field excitation provided by CW immersion, threat-level illumination, or another threat-relatable method. Coupling and PCI test details are provided in Appendix B.

If the antenna subsystem HEMP protection cannot be designed to satisfy the residual internal stress limits or functional requirements without interfering with operational signals that it is required to pass, a special protective volume shall be established (see 5.8.3.2).

MIL-STD-188-125-2

5.7.1.4.3 Shield injection requirements for antenna line POE protective devices. A Norton source with a 800-A short-circuit current, ≤ 20 -ns risetime and 500-550-ns FWHM, and ≥ 60 - Ω source impedance, connected to the shield of a buried antenna line at a point outside the electromagnetic barrier, shall produce residual internal response stresses no greater than peak currents in table IIb on the core conductor and shield and shall not cause device damage or performance degradation⁴. A Norton source with a 1,000-A short-circuit current, ≤ 20 -ns risetime and 500-550-ns FWHM, and ≥ 60 - Ω source impedance, connected to the shield of a nonburied intrasite antenna line (see 5.1.4.1) at a point outside the electromagnetic barrier, shall produce residual internal response stresses no greater than peak currents in table IIb on the core conductor and shield and shall not cause device damage or performance degradation⁴. A Norton source with a 5,000-A short-circuit current, ≤ 20 -ns risetime and 500-550-ns FWHM, and ≥ 60 - Ω source impedance, connected to the shield of a nonburied long antenna line (see 5.1.4.2) at a point outside the electromagnetic barrier, shall produce residual internal response stresses no greater than peak currents in table IIb on the core conductor and shield and shall not cause device damage or performance degradation⁴. An antenna line is considered buried when it terminates at a buried antenna and < 1 m (3.3 ft) of its total length is not covered by earth or concrete. If either of these conditions is not satisfied, the antenna line is considered nonburied.

5.7.1.5 Acceptance testing of electrical POE protective devices. Acceptance testing of electrical POE protective devices shall be conducted using the PCI test procedures of Appendix B. Acceptance testing of fiber optic POE waveguides below cutoff shall be conducted using shielding effectiveness test procedures of Appendix A. All defects found during the acceptance testing shall be corrected, retested, and shown to provide the required performance.

5.7.2 Long-line protection modules. LLPMs shall be provided, except on long RF antenna lines, to isolate the intrasite cable plant and the mission-critical subsystems and equipment from transients that can be induced on the long-lines by the HEMP threat environment. LLPMs are required under all of the following conditions:

- a. Where a commercial electrical power cable, a commercial telephone cable, or another long-line power, control, signal, or data electrical cable that extends beyond the transportable system deployment site interfaces to the intrasite cable plant, whether the associated intrasite cables connect to mission-critical or noncritical elements of the system.
- b. Where a long-line segment of an interconnecting power, control, signal, or data cable (see 5.1.4.2) interfaces to the intrasite cable plant, when the associated intrasite cables connect to one or more mission-critical elements of the system.
- c. Where a long-line segment of an interconnecting power, control, signal, or data cable interfaces to the intrasite cable plant, when the associated intrasite cables connect to a noncritical

MIL-STD-188-125-2

system element that is then interconnected to a mission-critical subsystem or equipment through any intrasite cable path.

LLPMs are not required on RF antenna lines.

The section of a long-line immediately before the connection at an LLPM shall be routed on the ground or shall be buried for a length of at least 16 m (52.5 ft).

5.7.2.1 General requirements for LLPMs. HEMP protection provided by LLPMs shall consist of linear and nonlinear transient suppression/attenuation devices or dielectric isolation techniques, as required to satisfy the performance requirements. When prescribed pulses (see table III) are injected at the long-line terminal of an LLPM, the norms of the residual response stresses at the intrasite cable terminal shall not exceed the maximums (see table IV) for the applicable class of LLPM⁵. Additionally, the LLPM shall be designed to withstand a sufficient number of test pulses at the prescribed current without damage or unacceptable performance degradation to accommodate life-cycle testing.

5.7.2.2 Power line LLPM requirements. A Norton source with a 2,500-A short-circuit current, ≤ 20 -ns risetime and 500-550-ns FWHM, and ≥ 60 - Ω source impedance, connected to the long-line terminal of a power line LLPM, shall produce a residual response stress at the intrasite cable terminal no greater than 250 A and shall not cause unacceptable LLPM damage or performance degradation⁵.

A Norton source with a 250-A short-circuit current, ≤ 1.5 - μ s risetime and 3-5-ms FWHM, and ≥ 10 - Ω source impedance, connected to the long-line terminal of a power line LLPM, shall not cause unacceptable LLPM damage or performance degradation⁵.

A Norton source with a 1,000-A short-circuit current, ≤ 0.2 -s risetime and 20-25-s FWHM, and ≥ 5 - Ω source impedance, connected to the long-line terminal of a power line LLPM, shall produce a residual response stress at the intrasite cable terminal no greater than 10 A and shall not cause unacceptable LLPM damage or performance degradation⁵.

5.7.2.3 Control, signal, and data line LLPM requirements. A Norton source with a 5,000/ \sqrt{N} or 500-A short-circuit current (where N is the number of conductors in the cable, and the larger amplitude is chosen), ≤ 20 -ns risetime and 500-550-ns FWHM, and ≥ 60 - Ω source impedance, connected to the long-line terminal of a control/signal/data line LLPM, shall produce a residual response stress at the intrasite cable terminal no greater than 500/ \sqrt{N} or 50 A

⁵ Detailed PCI requirements for LLPMs, including common mode test requirements, waveforms for the injected pulses, circuit test configuration information, and additional constraints on the residual response stress, are contained in tables III and IV and in the PCI test procedures of Appendix B.

MIL-STD-188-125-2

TABLE III. Norton source parameters, waveforms, and acceptance test loads for LLPm injection specifications.

Class of LLPm/ Type of Injection ¹	Peak Short- Circuit Current (A)	Source Impedance (ohms)	Risetime (s)	FWHM (s)	Acceptance Test Resistance (ohms)
Power line LLPms					
Short pulse common mode ²	5,000	≥ 60	≤ 2×10 ⁻⁸	5×10 ⁻⁷ - 5.5×10 ⁻⁷	Not applicable
Short pulse wire-to-ground ³	2,500	≥ 60	≤ 2×10 ⁻⁸	5×10 ⁻⁷ - 5.5×10 ⁻⁷	2
Intermediate pulse common mode ²	250	≥ 10	≤ 1.5×10 ⁻⁶	3×10 ⁻³ - 5×10 ⁻³	Not applicable
Intermediate pulse wire-to-ground ³	250	≥ 10	≤ 1.5×10 ⁻⁶	3×10 ⁻³ - 5×10 ⁻³	50
Long pulse common mode ²	⁴ 1,000	≥ 5	≤ 0.2	⁴ 20-25	Not applicable
Long pulse wire-to-ground ³	⁴ 1,000	≥ 5	≤ 0.2	⁴ 20-25	50
Control/signal/data line LLPms					
Short pulse common mode ²	5,000	≥ 60	≤ 2×10 ⁻⁸	5×10 ⁻⁷ - 5.5×10 ⁻⁷	Not applicable
Short pulse wire-to-ground ³	⁵ 5,000/√N or 500	≥ 60	≤ 2×10 ⁻⁸	5×10 ⁻⁷ - 5.5×10 ⁻⁷	50
Intermediate pulse common mode ²	250	≥ 10	≤ 1.5×10 ⁻⁶	3×10 ⁻³ - 5×10 ⁻³	Not applicable
Intermediate pulse wire-to-ground ³	250	≥ 10	≤ 1.5×10 ⁻⁶	3×10 ⁻³ - 5×10 ⁻³	50
Long pulse common mode ²	⁴ 1,000	≥ 5	≤ 0.2	⁴ 20-25	Not applicable
Long pulse wire-to-ground ³	⁴ 1,000	≥ 5	≤ 0.2	⁴ 20-25	50

MIL-STD-188-125-2

TABLE III. Norton source parameters, waveforms, and acceptance test loads for LLPM injection specifications - Continued.

Notes.

¹ Pulsed current injection specifications are defined in terms of the Norton equivalent sources. Double-exponential waveforms are used in all LLPM PCI specifications. Peak short-circuit current is the peak time-domain current into a short-circuit calibration load at the pulser output terminals. Source impedance is the pulser peak time-domain open-circuit voltage divided by the peak time-domain short-circuit current. Risettime is the 10-percent to 90-percent risetime. Full-width at half-maximum amplitude (FWHM) is the time interval between the 50-percent amplitude points.

The source parameters are generally specified by the minimum acceptable source impedance and the maximum acceptable risetime. This is done for the sole purpose of experimental practicality, so that the current injection sources are not required to precisely match prescribed waveforms.

² For a common mode test, all conductors in the cable are simultaneously driven with respect to the LLPM ground connection point. Common mode testing is required for verification, but is not required for acceptance.

³ For a wire-to-ground test, each of the conductors in the cable is individually driven with respect to the LLPM ground connection point.

⁴ The long pulse peak short-circuit current (1,000 A) and FWHM (20-25 s) are design objectives. Any double-exponential waveform with a peak amplitude ≥ 200 A, risetime ≤ 0.2 s, and peak current \times FWHM product $\geq 2 \times 10^4$ A-s satisfies the minimum requirement.

⁵ N is the number of conductors in the cable. The larger of these two amplitudes is required.

MIL-STD-188-125-2

TABLE IV. Maximum allowable residual response norms for LLPM injection specifications.

Class of LLPM/ Type of Injection	Type of Measurement	Peak Current (A)	Peak Rate of Rise (A/s)	Root Action (A ⁻¹ √s)
Power line LLPMs				
Short pulse common mode	Bulk current	≤ 500	≤ 2.5×10 ¹⁰	≤ 3.1×10 ⁻¹
Short pulse wire-to-ground	Wire current	≤ 250	≤ 1.3×10 ¹⁰	≤ 1.6×10 ⁻¹
Intermediate pulse common mode	Bulk current	No damage or performance degradation ¹	No damage or performance degradation ¹	No damage or performance degradation ¹
Intermediate pulse wire-to-ground	Wire current	No damage or performance degradation ¹	No damage or performance degradation ¹	No damage or performance degradation ¹
Long pulse common mode	Bulk current	³ ≤ 10	³ ≤ 50	³ ≤ 37
Long pulse wire-to-ground	Wire current	³ ≤ 10	³ ≤ 50	³ ≤ 37
Control/signal/data line LLPMs				
Short pulse common mode	Bulk current	≤ 500	≤ 2.5×10 ¹⁰	≤ 3.1×10 ⁻¹
Short pulse wire-to-ground	Wire current	² ≤ 500/√N or 50	² ≤ 2.5×10 ¹⁰ /√N or 2.5×10 ⁹	² ≤ 3.1×10 ⁻¹ /√N or 3.1×10 ⁻²
Intermediate pulse common mode	Bulk current	No damage or performance degradation ¹	No damage or performance degradation ¹	No damage or performance degradation ¹
Intermediate pulse wire-to-ground	Wire current	No damage or performance degradation ¹	No damage or performance degradation ¹	No damage or performance degradation ¹
Long pulse common mode	Bulk current	³ ≤ 10	³ ≤ 50	³ ≤ 37
Long pulse wire-to-ground	Wire current	³ ≤ 10	³ ≤ 50	³ ≤ 37

MIL-STD-188-125-2TABLE IV. Maximum allowable residual response norms for LLP_M injection specifications - Continued.

Notes.

- ¹ Pass/fail criteria on the residual response norms are not specified for the intermediate pulse current injection test sequence. The pass/fail criteria of no POE protective device damage or performance degradation also applies to PCI test sequences where this note does not appear in the table.
- ² N is the number of conductors in the cable. The larger of these two amplitudes is the maximum allowable norm limit.
- ³ The maximum allowable norm limits listed for the long pulse test sequence assume the use of a 1,000-A drive pulse, with risetime ≤ 0.2 s and FWHM ≥ 20 s. When other allowed drive pulses are used, the LLP_M is required to attenuate the peak current, peak rate of rise, and root action norms by a factor of at least 100.

MIL-STD-188-125-2

(whichever is larger) and shall not cause unacceptable LLPM damage or performance degradation⁵.

A Norton source with a 250-A short-circuit current, $\leq 1.5\text{-}\mu\text{s}$ risetime and 3-5-ms FWHM, and $\geq 10\text{-}\Omega$ source impedance, connected to the long-line terminal of a control/signal/data line LLPM, shall not cause unacceptable LLPM damage or performance degradation⁵.

A Norton source with a 1,000-A short-circuit current, $\leq 0.2\text{-s}$ risetime and 20-25-s FWHM, and $\geq 5\text{-}\Omega$ source impedance, connected to the long-line terminal of a control/signal/data line LLPM, shall produce a residual response stress at the intrasite terminal no greater than 10 A and shall not cause unacceptable LLPM damage or performance degradation⁵.

5.7.2.4 Acceptance testing of LLPMs. Acceptance testing of power line LLPMs and control/signal/data line LLPMs shall be conducted using the PCI test procedures of Appendix B. All defects found during the acceptance testing shall be corrected, retested, and shown to provide the required performance.

5.8 Special protective measures. In special cases where HEMP hardness cannot be achieved with the electromagnetic barrier alone (see 4.3.6), special protective measures shall be implemented. Special protective measures shall not be used as a substitute for an electromagnetic barrier that satisfies the performance requirements of this standard.

5.8.1 MCE outside the subsystem electromagnetic barriers. Special protective measures shall be implemented to HEMP harden MCE that are placed outside the subsystem electromagnetic barriers IAW provisions of this standard (see 5.1.2). Special protective measures for MCE outside the subsystem electromagnetic barriers may include:

- a. Cable, conduit, and local volume shielding,
- b. Linear and nonlinear transient suppression/attenuation devices,
- c. Equipment-level hardening measures (reduced coupling cross-section, dielectric means of signal and power transport, use of inherently robust components),
- d. Remoting sensitive circuits to locations within a protected volume,
- e. Automatic recycling features or operator intervention schemes, when the mission timeline permits,
- f. Other hardening measures appropriate for the particular equipment to be protected.

MIL-STD-188-125-2

Performance requirements for the special protective measures shall ensure that the upper-bound, HEMP-induced peak time-domain current stresses at the equipment level are less than the vulnerability thresholds of the equipment⁶.

5.8.1.1 RF communications antennas outside the subsystem electromagnetic barriers.

Mission-critical RF antennas and any associated antenna-mounted electronics, tuning circuits, and antenna cables located outside the subsystem electromagnetic barriers shall be HEMP hardened as MCE outside the subsystem electromagnetic barriers. Performance requirements for the special protective measures shall ensure that the upper-bound, HEMP-induced peak time-domain current stresses at the equipment level are less than the vulnerability thresholds of the equipment⁶.

5.8.2. MCE that is inside a subsystem electromagnetic barrier and fails verification testing.

Special protective measures shall be implemented to HEMP harden MCE that are placed inside the subsystem electromagnetic barrier, but experience mission-aborting damage or upset during verification testing. Special protective measures for MCE inside a subsystem electromagnetic barrier may include cable, conduit, and local volume shielding; transient suppression/attenuation devices; equipment-level hardening measures; remoting sensitive circuits; automatic recycling features; operator intervention schemes; and other hardening measures appropriate for the particular equipment to be protected. Performance requirements for the special protective measures shall ensure that the upper-bound, HEMP-induced peak time-domain current stresses at the equipment level are less than the vulnerability thresholds of the equipment⁶.

5.8.3 Special protective volumes.

5.8.3.1 Special protective volumes for piping POEs. When a piping POE WBC must be larger than the dimension corresponding to a cutoff frequency of at least 1.5 GHz to provide adequate fluid flow and a waveguide-below-cutoff array insert cannot be used, a special protective volume shall be established inside the main subsystem electromagnetic barrier (figure 9a). The piping POE shall be protected with a special waveguide.

5.8.3.1.1 Special waveguide requirements. A WBC having a cutoff frequency less than 1.5 GHz shall be of the minimum inside transverse dimension consistent with its functional requirements. The length of the special waveguide section shall be at least five times its maximum inside transverse dimension. All joints and couplings in the special waveguide section shall be electromagnetically closed. No dielectric linings shall be permitted in the special waveguide section.

⁶ See MIL-HDBK-423 for methods of determining the upper-bound HEMP-induced stresses and vulnerability thresholds.

MIL-STD-188-125-2

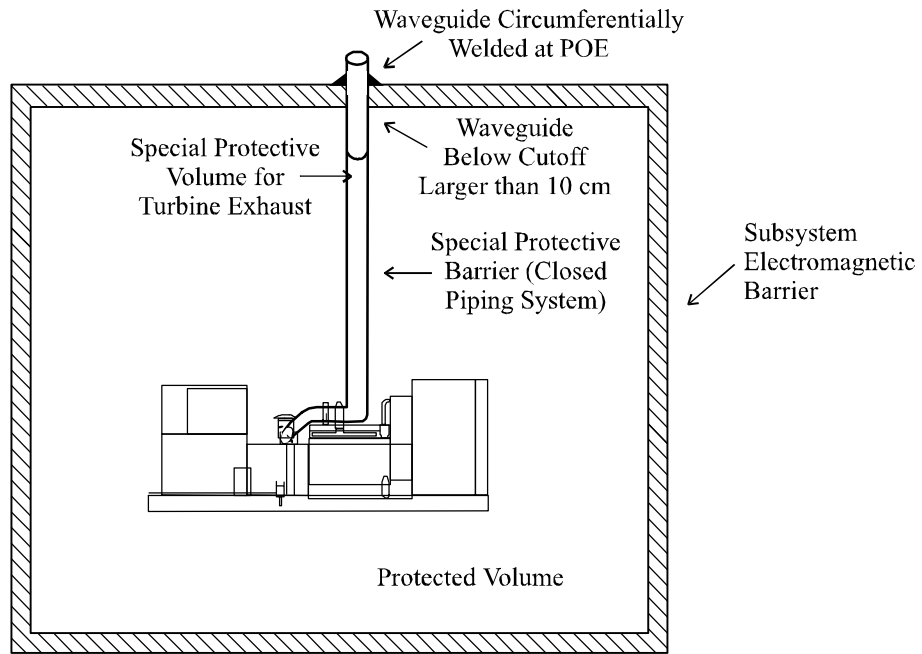

a. Special protective volume for piping POE.

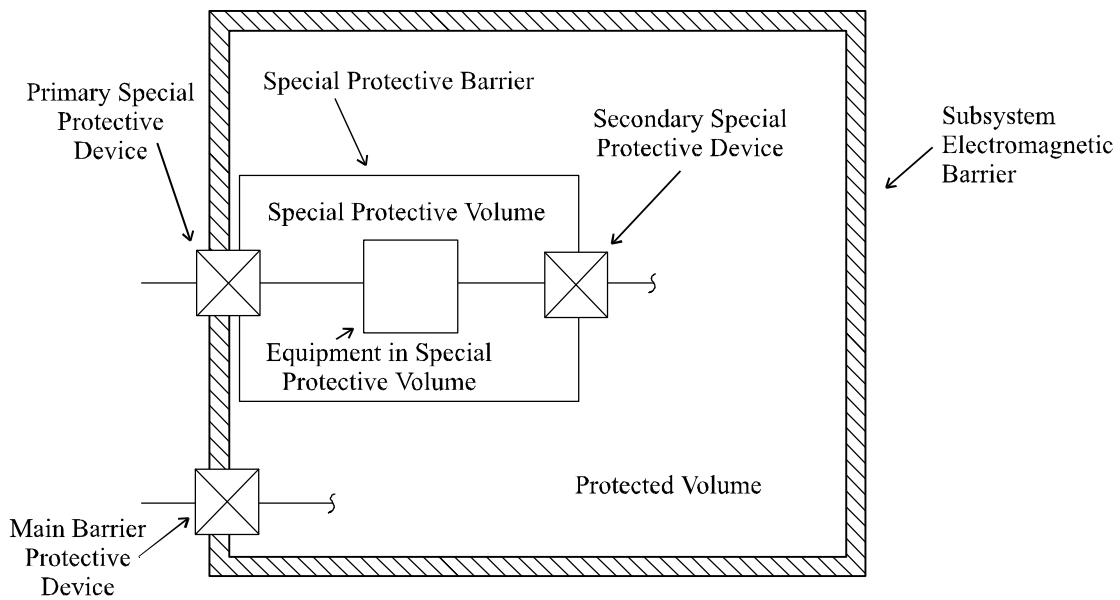

b. Special protective volume for electrical POE.

FIGURE 9. Typical special protective volumes.

MIL-STD-188-125-2

5.8.3.1.2 Special protective barriers for piping POEs. The special protective barrier shall completely enclose the piping that is protected at its POE with a waveguide below cutoff having a cutoff frequency less than 1.5 GHz. The special protective barrier may be a separate shield with protected penetrations, or it may be implemented using the metal walls of the closed piping system itself. Performance requirements for the special protective barrier shall ensure that the total shielding effectiveness, measured through the main subsystem electromagnetic barrier and special protective barrier, satisfies at least the minimum requirements shown on figure 4.

5.8.3.2 Special protective volumes for electrical POEs. When an electrical POE protective device cannot be designed to achieve the transient suppression/attenuation requirements prescribed for the applicable class of electrical POE (see 5.7.1) without interfering with operational signals it is required to pass, a special protective volume shall be established inside the main subsystem electromagnetic barrier (figure 9b). The electrical POE shall be protected with a primary special electrical POE protective device.

5.8.3.2.1 Primary special electrical POE protective device requirements. A primary special electrical POE protective device shall be substituted for a main barrier protective device that cannot achieve the prescribed transient suppression/attenuation performance (see 5.7.1) without interfering with the operational signals it is required to pass. The primary special protective device shall be designed to provide the maximum transient suppression/attenuation consistent with its functional requirements. A Norton source with pulse parameters prescribed for the applicable class of electrical POE (see table I), connected to the penetrating conductor at the primary special protective device external terminal, shall produce a residual internal transient stress no greater than the design value for the associated special protective volume and shall not cause device damage or performance degradation⁴.

5.8.3.2.2 Secondary special electrical POE protective device requirements. When the combination of the primary special electrical POE protective device and the directly connected equipment cannot achieve the transient suppression/attenuation requirements for the applicable class of electrical POE (see 5.7.1), a secondary special electrical POE protective device shall be provided (figure 9b). Performance requirements for the secondary special protective device shall ensure that the total transient suppression/attenuation through the primary special protective device, the connected equipment, and the secondary special protective device satisfies at least the minimum requirements prescribed for the applicable class of electrical POE without device damage or performance degradation⁴.

5.8.3.2.3 Special protective barriers for electrical POEs. The special protective barrier shall completely enclose the wiring and equipment directly connected to the primary special electrical POE protective device. The special protective barrier may be a separate shield with protected

MIL-STD-188-125-2

penetrations, or it may be implemented using cable and conduit shields and equipment cabinets. Performance requirements for the special protective barrier shall ensure that the total shielding effectiveness, measured through the main subsystem electromagnetic barrier and special protective barrier, satisfies at least the minimum requirements shown on figure 4.

5.8.3.2.4 MCE in special protective volumes. Special protective measures shall be implemented as necessary to HEMP harden MCE in a special protective volume to the HEMP-induced electromagnetic stresses that are allowable in that volume. Special protective measures for MCE in a special protective volume may include cable, conduit, and local volume shielding; transient suppression/attenuation devices; equipment-level hardening measures; remoting sensitive circuits; automatic recycling features; operator intervention schemes; and other hardening measures appropriate for the particular equipment to be protected. Performance requirements for the special protective measures shall ensure that the upper-bound, HEMP-induced peak time-domain current stresses at the equipment level are less than the vulnerability thresholds of the equipment⁶.

5.8.4 Acceptance testing for special protective measures.

5.8.4.1 Special protective measures for MCE. Acceptance testing is not required for equipment-level special protective measures installed on MCE IAW 5.8.1, 5.8.2, and 5.8.3.2.4. HEMP hardness provided by these special protective measures shall be demonstrated during the verification test program.

5.8.4.2 Special protective barriers. Acceptance testing for all special protective barriers shall be conducted using shielding effectiveness test procedures of Appendix A. Additionally, acceptance testing for all primary and secondary special electrical POE protective devices shall be conducted using the PCI test procedures of Appendix B. All defects found during the acceptance testing shall be corrected, retested, and shown to provide the required performance.

5.9 Reliability and maintainability. The HEMP protection shall be designed, fabricated, and assembled to be rugged, reliable, and maintainable. Reliability and maintainability tasks and requirements shall be included in the system acquisition specifications to ensure that reliability is considered in component selections and assembly processes; to minimize the frequency, complexity, and costs of design-dictated maintenance; and to provide adequate provisioning with spare HCIs and maintenance tools and supplies.

5.10 Safety and human engineering. Safety and human engineering criteria, principles, and practices shall be applied in the design, selection, and placement of the HEMP protective elements. Entryways shall be designed to accommodate the required traffic flow, and shielded doors shall operate simply with forces within human engineering limits. Inspection covers shall be designed for safety and ease of removal and proper reinstallation. Electrical POE protective

MIL-STD-188-125-2

devices shall include fail-safe features, such as safety covers and capacitor discharge provisions, for protection of personnel during installation, operation, maintenance, and repairs.

5.11 Testability. The HEMP protection shall be designed, fabricated, and assembled to accommodate quality assurance, acceptance, and verification testing and HM/HS. The subsystem HEMP shields shall be accessible for visual inspection at all POEs. Access for periodic shielding effectiveness measurements shall be provided. Electrical POE protective devices shall be installed with accessible PCI drive points and measurement points.

5.12 Corrosion control. Corrosion protection measures shall be implemented in the design, fabrication, and assembly of the HEMP protection. The subsystem HEMP shields and POE protective devices shall be fabricated using inherently corrosion-resistant materials or shall be coated or metallurgically processed to resist corrosion. Joints between dissimilar metals shall be avoided and, where required, shall be provided with corrosion prevention treatments. Pockets where water or condensation can collect shall be avoided. Corrosion protection shall be provided for conduits, cables, and connectors in the external cable plant. Cathodic protection shall be provided, where required by environmental conditions at deployment sites.

5.13 Configuration management. A hardness configuration management program shall be implemented during design, fabrication, and assembly of the HEMP protection. Hardness critical items and hardness critical processes shall be identified in the system drawings IAW MIL-STD-100, and installed HCIs shall be distinctively marked with Hardness Critical Labels, DD Forms 2639, or Hardness Critical Tags, DD Forms 2640, as appropriate. System design, fabrication, and assembly changes shall be assessed for potential HEMP hardness impacts prior to approval. The affected portions of the HEMP protection shall be retested when major configuration changes occur after acceptance testing.

5.14 Verification testing. After the HEMP protection has been accepted, the MCE has been installed, and the system is operational, a verification test program shall be conducted. As a minimum, the verification testing shall include all of the procedures listed under Option A or under Option B in table V. A combination of options, where some system elements are verification tested with the Option A procedures and the remaining elements are tested using Option B procedures, is also permitted. All of the deficiencies identified by the verification test program shall be corrected and retested until the required hardness has been achieved.

5.14.1 CW immersion testing. CW immersion testing, when conducted as part of the verification test program, shall be performed IAW procedures of Appendix C. At frequencies where the measurement range exceeds the attenuation requirements shown on figure 4, ratios of the illuminating field strength to the residual internal field strength shall be greater than or equal to the minimum shielding effectiveness requirement. Residual internal field strength shall be less than or equal to the instrumentation noise or operating signal level at frequencies where the

MIL-STD-188-125-2

measurement range is less than the attenuation requirements shown on figure 4. Residual internal current measurements, when extrapolated to threat using equations defined in Appendix C, shall be ≤ 0.1 A, and the peak derivatives of the threat-extrapolated currents shall be $\leq 1 \times 10^7$ A/s.

TABLE V. Verification test program options.

HEMP Protection Feature	Option A Verification Test Program	Option B Verification Test Program
Subsystem HEMP shields and aperture POE protection	CW immersion (or shielding effectiveness and SELDS) (see Appendix C)	Threat-level illumination (see Appendix D)
Electrical POE protection	PCI (see Appendix B)	PCI (see Appendix B)
Long-line protection modules	PCI (see Appendix B)	PCI (see Appendix B)
Special Protective Measures	System-specific tests	System-specific tests
• MCE outside barriers	CW immersion coupling test and PCI tests (see 5.14.4.1)	Threat-level illumination coupling test and PCI tests (see 5.14.4.1)
• MCE that are inside barrier and fail verification test	CW immersion coupling test and PCI tests (see 5.14.4.1)	Threat-level illumination coupling test and PCI tests (see 5.14.4.1)
• RF communications antennas	CW immersion coupling test and PCI tests (see Appendix B)	Threat-level illumination coupling test and PCI tests (see Appendix B)
• Special protective volume shields	Included in CW immersion (or shielding effectiveness and SELDS) test	Included in threat-level illumination test
• Primary and secondary special electrical POE protective devices	PCI (see 5.14.4.2)	PCI (see 5.14.4.2)
• MCE in special protective barriers	CW immersion coupling test and PCI tests (see 5.14.4.1)	Threat-level illumination coupling test and PCI tests (see 5.14.4.1)

When approved by the sponsoring agency for the verification test, shielding effectiveness measurements IAW procedures of Appendix A and a thorough shielding effectiveness leak detection system (SELDS) survey IAW MIL-HDBK-423 guidance may be performed in lieu of the CW immersion test.

5.14.2 PCI verification testing. PCI verification testing shall be performed IAW procedures of Appendix B. Norms of the measured residual internal transient currents shall not exceed the maximum allowable limits for the applicable class of electrical POE. POE protective devices

MIL-STD-188-125-2

shall not be damaged or experience unacceptable performance degradation from the simulated HEMP excitations. No mission-aborting damage or upsets of the MCE shall occur⁷.

5.14.3 Threat-level illumination testing. Threat-level illumination testing, when conducted as part of the verification test program, shall be performed IAW procedures of Appendix D. The ratio of the peak time-domain simulator incident field strength to the peak time-domain residual internal field strength shall be ≥ 80 dB at each internal field measurement location. Peak amplitudes of the measured residual internal transient currents shall be ≤ 0.1 A, and the peak derivative of the measured transient currents shall be $\leq 1 \times 10^7$ A/s. No mission-aborting damage or upsets of the MCE shall occur⁷.

5.14.4 Verification testing of special protective measures. System-specific procedures for verification testing of special protective measures shall be developed, based upon the test approaches in paragraphs 5.14.4.1 and 5.1.14.2. The verification testing shall demonstrate that HEMP-induced electromagnetic stresses resulting from system exposure to the threat environment of MIL-STD-2169 will not cause mission-aborting damage or upsets of the MCE⁷.

5.14.4.1 Verification testing of MCE hardened with special protective measures. Verification testing of MCE hardened with special protective measures shall generally include coupling measurements and pulsed current injection testing. The system excitation for the coupling measurements shall be provided using CW immersion, threat-level illumination, subthreat transient field illumination, CW or pulsed current injection, or other threat-relatable methods. MCE cable currents shall be measured and extrapolated to the upper-bound HEMP-induced responses for the MIL-STD-2169 threat environment. The extrapolation shall include a factor of 10 to account for uncontrollable coupling parameters, such as departure from planarity and ground conductivity, and other uncertainties. The upper-bound HEMP-induced currents shall then be used as the drive levels for the pulsed current injection testing.

Long lines that connect to the MCE via LLPMS shall be tested with injected pulses of the amplitudes and waveforms prescribed in Appendix B for the applicable classes of LLPMS. Intrasite conductors that connect to the MCE and are directly exposed to the HEMP environment shall be tested with injected pulses of the amplitudes and waveforms prescribed for PCI testing of the applicable classes of electrical POE protective devices.

Cables that connect or are internal to the MCE and are not directly exposed to the HEMP environment shall be tested with injected pulses having characteristics that comply with one of the following requirements:

⁷ The determination whether observed damage or upsets are mission-aborting is the responsibility of the operational authority for the system.

MIL-STD-188-125-2

- a. Amplitudes equal to the upper-bound, HEMP-induced peak time-domain current stresses, and waveforms similar to those of the applicable threat-extrapolated currents,
- b. Amplitudes and waveforms prescribed for PCI testing of the applicable classes of electrical POE protection devices.

These verification test excitations shall not cause mission-aborting damage or upsets of the MCE⁷.

5.14.4.2 Verification testing of special protective barriers. Verification testing of special protective barriers shall include tests on the special protective barrier shield and penetration protective devices. During the system CW immersion test (see 5.14.1) or system threat-level illumination test (see 5.14.3), measurements for verifying the performance of special protective shields and aperture penetration protection treatments shall be acquired, analyzed, and shown to provide at least the required shielding effectiveness.

Verification testing of primary and secondary special electrical POE protective devices shall be performed IAW procedures of Appendix B. In addition to the measurements in the special protective volume and functional observations required by 5.14.4.1, residual internal transient stresses shall be measured on conductors that penetrate from the special protective volume into the protected volume. Norms of the responses at test points within the protected volume shall not exceed the applicable maximum allowable limits, and the test excitations shall not cause mission-aborting damage or upsets of the MCE⁷.

5.15 HM/HS program requirements. Logistics support analysis for the HEMP protection measures shall be performed during the system acquisition phase. The logistics support analysis shall define the HM/HS requirements, supply support requirements, training requirements, and technical data requirements for the HEMP protection.

5.15.1 Hardness surveillance/reverification test procedures. Detailed hardness surveillance/reverification test procedures for the HEMP protection shall be provided. The HS tasks shall be performed on a periodic basis, as specified in the HM/HS program. The reverification test results shall be correlatable to the verification test results and shall have the same pass/fail criteria. The procedures shall identify the tests to be conducted, frequency of testing, test equipment requirements, safety precautions, and other relevant information.

5.15.2 Maintenance and inspection procedures. Detailed procedures for preventive maintenance and inspection and for repair and replacement of HEMP hardness critical assemblies or items shall be provided. Preventive maintenance and inspection procedures shall be designed, where practical, to be implemented at the organizational level and shall define the tasks to be performed; frequency of performance; pass/fail criteria, where applicable; safety precautions, and

MIL-STD-188-125-2

other relevant information. Repair and replacement procedures shall identify the tasks to be performed; hardness requirements, including pass/fail criteria and post-repair test requirements; safety precautions; and other relevant information.

5.15.3 Supply support requirements. A parts list of the installed HEMP hardness critical assemblies and items and lists of recommended organizational HEMP protection spare parts, repair parts, supplies, special tools, and special test equipment shall be provided. The lists shall identify the nomenclature or description of each item; the manufacturer and manufacturer's part number; the federal stock number, when assigned; the required quantity; and other relevant information. All spare hardness critical assemblies and items shall be marked using Hardness Critical Labels, DD Forms 2639, or Hardness Critical Tags, DD Forms 2640, as appropriate.

5.15.4 Training requirements. HEMP training requirements for operators and maintenance personnel assigned to the hardened system shall be defined. As a minimum, the training program shall include organizational HEMP awareness training for all system personnel and classroom and on-the-job training for HM/HS personnel. Training materials shall be provided for all training to be administered at the organizational level.

5.15.5 Technical data. A HEMP protection technical manual shall be provided. As a minimum, the technical manual shall include the following:

- a. Description and principles of operation of the HEMP protection,
- b. HCI maintenance and inspection procedures, repair and replacement procedures, and hardness surveillance/reverification test procedures,
- c. Supply support requirements,
- d. Training requirements.

5.15.6 Delivery. The HEMP protection technical manual shall be delivered with the system. Recommended organizational HEMP spare parts, repair parts, supplies, special tools, special test equipment, and training materials shall also be delivered with the system.

5.15.7 Implementation. Preventive maintenance, inspections, and hardness surveillance/reverification testing shall be performed IAW the technical manual. Corrective maintenance shall be performed if the performance of the HEMP protection degrades below the minimum requirements of this standard. Hardness surveillance/reverification testing shall be performed at intervals not exceeding seven years.

MIL-STD-188-125-2

6.0 NOTES

(This section contains information of a general or explanatory nature that may be helpful, but is not required.)

6.1 Intended use. This standard contains minimum requirements and design objectives for low-risk HEMP protection of transportable ground-based systems that perform critical, time-urgent C⁴I missions. The purpose is to standardize design, fabrication, assembly, and testing of the HEMP protection for these systems and to thereby ensure the quality and durability of the hardening.

Low-risk HEMP protection is military unique because it is required only for critical C⁴I assets that support time-urgent attack warning and retaliatory military missions. While other military and commercial systems may require HEMP protection, there are no commercial requirements for low-risk hardening.

6.2 Issue of DoDISS. When this standard is used in acquisition, the applicable issue of the DoDISS must be cited in the solicitation (see 2.2.1 and 2.3).

6.3 Subject term (key word) listing.

- Continuous wave immersion
- Electromagnetic barrier
- Electric surge arrester
- Hardening
- Hardness verification
- High-altitude electromagnetic pulse
- Low-risk HEMP protection
- Mission-critical equipment
- Nuclear survivability
- Point-of-entry
- POE protective device
- Pulsed current injection
- Shielding effectiveness
- Special protective measures
- Subsystem HEMP shield
- Survivability/vulnerability
- Transient suppression/attenuation device
- Waveguide below cutoff

MIL-STD-188-125-2**APPENDIX A****SHIELDING EFFECTIVENESS (SE) TEST PROCEDURES
FOR TRANSPORTABLE GROUND-BASED SYSTEMS****A.1 GENERAL**

A.1.1 Scope. This Appendix is a mandatory part of this standard. The information contained herein is intended for compliance. This Appendix establishes procedures for measuring the shielding effectiveness of the electromagnetic barriers required for low-risk high-altitude electromagnetic pulse (HEMP) protection of transportable ground-based systems with critical, time-urgent missions. The procedures are applicable for testing other HEMP-hardened systems, when specified by the procurement documentation.

A.1.2 Applications. These procedures shall be used for shielding effectiveness acceptance testing of the subsystem shields and aperture point-of-entry (POE) protective treatments. The procedures shall also be performed for acceptance of repairs or installations of new POE protective devices after subsystem shield acceptance, except that only areas affected by the repairs or installations are required to be tested. Shielding effectiveness measurements may also be conducted as part of the verification test program.

A.2 REFERENCED DOCUMENTS

A.2.1 Government documents. The following Government documents form a part of this Appendix to the extent specified:

DI-NUOR-80928	–	Nuclear Survivability Test Plan
DI-NUOR-80929A	–	Nuclear Survivability Test Report
DNA-EMP-1	–	Electromagnetic Pulse (EMP) Security Classification Guide (U) (document is classified S-RD)

(Copies of documents required by contractors in connection with specific acquisition functions should be obtained from the contracting activity or as directed by the contracting officer.)

A.2.2 Non-Government publications. The following publications form a part of this Appendix to the extent specified:

IEEE-Std-299	–	Standard for Measuring the Effectiveness of Electromagnetic Shielding Enclosures
--------------	---	----------------------------------------------------------------------------------

MIL-STD-188-125-2**APPENDIX A**

IEEE-Std-488.1 – Standard Digital Interface for Programmable Instrumentation

(Applications for copies should be addressed to the Institute for Electrical and Electronics Engineers [IEEE], 445 Hoes Lane, Post Office Box 1331, Piscataway, NJ 08855-1331.)

A.3 DEFINITIONS

A.3.1 Test area (or test point) shielding effectiveness. For purposes of this procedure, the frequency-dependent ratio in decibels (dB) of the received signal when the receiving antenna is illuminated by electromagnetic radiation in the calibration configuration (no shield present) to the signal received through the electromagnetic barrier in the measurement configuration. Assuming that antenna voltage proportional to field strength is measured:

$$SE = 20 \log \left(\frac{V_c}{V_m} \right)$$

where V_m is the measured signal at the test area (or test point), V_c is the calibration signal at the same frequency and polarization, and appropriate corrections are applied for any differences in instrumentation system gain/attenuation between the calibration and measurement configurations. Shielding effectiveness values are test method-method dependent, and different values may be obtained when time-domain or other frequency-domain measurement techniques are used.

A.4 GENERAL REQUIREMENTS

A.4.1 General. This HEMP shielding effectiveness test method is similar to IEEE-Std-299, except that the requirements have been modified to evaluate the barrier performance with a stepped-frequency test method using a minimum set of test areas and test points. A transmitting antenna is placed on one side of the electromagnetic barrier on the measurement axis through the center of each test area (or test point). The receiving antenna is centered on the test area (or test point) on the opposite side of the barrier. The instrumentation is then stepped through the measurement frequencies, and the measured data are recorded. Magnetic shielding effectiveness measurements are made at frequencies from 10 kHz through 20 MHz. Resonant range/plane

MIL-STD-188-125-2

APPENDIX A

wave shielding effectiveness is measured from 20 MHz through 1 GHz. Selections of test areas and test points, test frequencies, and polarizations of the antennas are defined in this Appendix.

A.4.2 Purpose. These procedures define shielding effectiveness, as used in this standard. The purpose of the measurements is to obtain shielding effectiveness data for demonstrating compliance with subsystem HEMP shield and aperture POE treatment performance requirements.

A.4.3 Subsystem HEMP protection test configuration. The shielding effectiveness acceptance test shall be conducted after fabrication and assembly of each subsystem HEMP shield, when the following prerequisite conditions are met. The HEMP shield assembly shall be complete. All POEs and their POE protective devices that are required as part of the shield assembly work shall be installed and in a normal operating condition. External wiring to conductive POE protective devices shall be disconnected. The test shall be performed before installation of the interior cabling, interior equipment, and interior finish work. A visual shield inspection shall be performed before starting the measurements to ensure that these configuration requirements have been met.

When shielding effectiveness measurements are performed as part of the verification test program, the subsystem under test shall be provided with electrical power and equipment in the protected volume shall be turned “on.” The subsystem HEMP protection shall be intact.

A.4.4 Analysis requirements. No pretest or post-test analyses are required for these procedures.

A.4.5 Test equipment requirements. Antennas and other test equipment requirements for these shielding effectiveness measurements are identified in table A-I. A typical instrumentation system is illustrated in figure A-1.

A.4.6 Operational impact analysis and risk. The electromagnetic barrier must remain intact during conduct of the shielding effectiveness measurement sequence. Use of electrically noisy equipment must be restricted, so that adequate signal-to-noise ratio (SNR) and measurement range of the test equipment are maintained. Manufacturing activity in the area or unusual operations, such as modifications or maintenance, may therefore be affected. Radiated signal levels are low and present no hazard to equipment, but frequency adjustments may be required to avoid interference with nearby systems. Normal electrical safety precautions apply. As required, radio frequency radiation protection shall be provided for test personnel.

MIL-STD-188-125-2**APPENDIX A**TABLE A-I. Shielding effectiveness test equipment requirements.

Equipment	Characteristics
Oscillators ¹	10 kHz - 1 GHz
Power Amplifiers	10 kHz - 1 GHz; power output as required for dynamic range
Preamplifiers	10 kHz - 1 GHz; amplification and noise figure as required for dynamic range
Receivers, Network Analyzers, or Spectrum Analyzers	10 kHz - 1 GHz
Antenna Kit ²	10 kHz - 1 GHz
Computer and GPIB Control Interfaces ³	As required
Fiber Optic Links ⁴	As required
Miscellaneous Cables, Attenuators, and Coaxial Switches	As required

¹ Oscillators may be integral to the receivers, network analyzers, or spectrum analyzers.

² Electrostatically shielded loop antennas are required in the low-frequency or magnetic regime (10 kHz to 20 MHz). Biconical antennas shall be used in the resonant frequency range (20 MHz to approximately 100 MHz). Log periodic or equivalent broad band antennas shall be used in the high-frequency or plane wave regime (approximately 100 MHz to 1 GHz). Antennas must radiate and receive over the prescribed frequency bands and, in conjunction with other test equipment, must satisfy the dynamic range requirement.

³ Use of a personal computer with an IEEE-488 general purpose interface bus (GPIB), or equivalent, to control instrumentation and store test data is strongly recommended.

⁴ Radio frequency (RF) and instrumentation control signals may be transmitted through the shield with appropriate fiber optic (F/O) links or high-quality, solid metal-shielded coaxial cables. Use of fiber optic links is strongly recommended.

MIL-STD-188-125-2

APPENDIX A

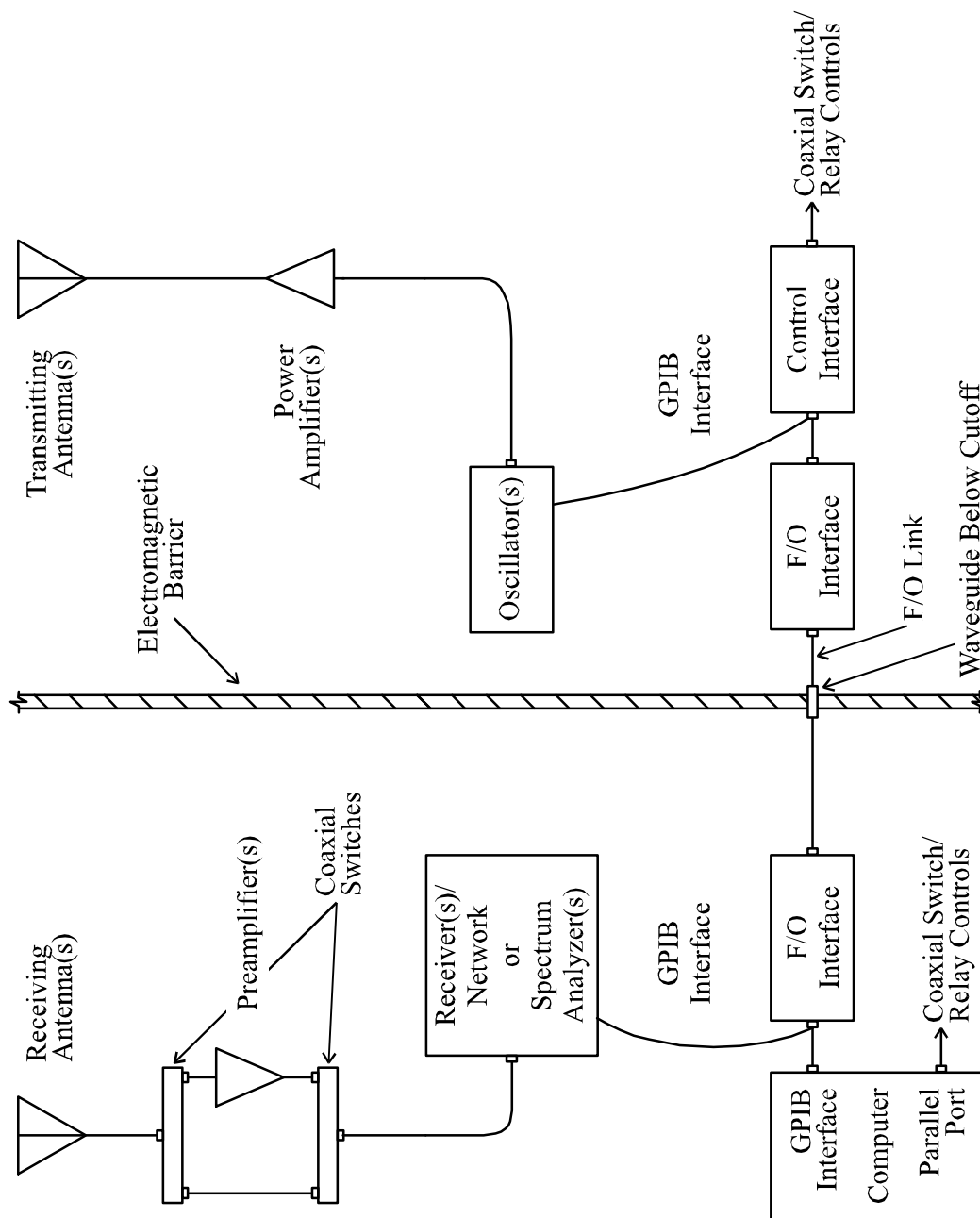

FIGURE A-1. Typical shielding effectiveness instrumentation system.

MIL-STD-188-125-2

APPENDIX A

A.4.7 Test plan and procedures. A shielding effectiveness test plan and detailed test procedures shall be prepared. These may be combined in a single document, or two separate documents may be used. As a minimum, the documentation shall contain the following information:

- a. Statement of test objectives.
- b. System identification and description.
- c. Test area identification. The entire surface of the electromagnetic barrier (including the floor shield when both sides are accessible) shall be divided into numbered plane areas no greater than 2.5 m x 2.5 m (8.2 ft x 8.2 ft), as illustrated in figure A-2. Whenever practical, test areas shall be centered on the principal seams of the shield. The shielding effectiveness measurement axis, which is the imaginary line between the transmitting antenna and receiving antenna locations, for each test area shall be normal to the shield surface and shall pass through the geometric center of the area. A list of POEs by test area shall be provided.
- d. Test point identification. Numbered test points shall be established at all architectural, mechanical, and electrical POEs. The measurement axes for test points shall be normal to the shield surface at the geometric centers of shielded doors, equipment access panels, and ventilation waveguide-below-cutoff arrays and at the centerlines of penetrating pipes or conduits for piping and electrical POEs.
- e. Identification of test frequencies.
- f. Test equipment identification by manufacturer, model and serial numbers, and detailed calibration procedures.
- g. Detailed measurement procedures.
- h. Procedures for marking, repairing, and retesting defects.
- i. Any deviations from the requirements of this Appendix.
- j. Data management (including data quality control procedures, data acceptability criteria, annotation and preservation of data records, and pass/fail criteria).
- k. Safety, including electromagnetic radiation and electrical shock hazards.

MIL-STD-188-125-2

APPENDIX A

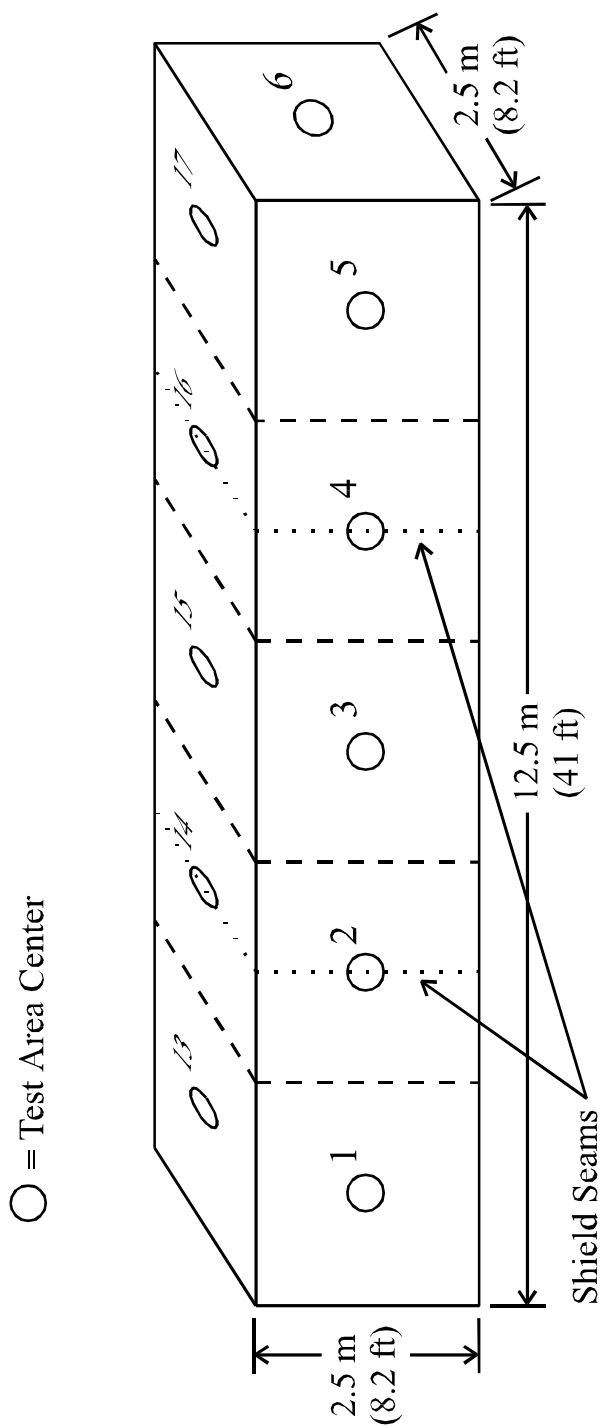

FIGURE A-2. Sample test area assignments.

MIL-STD-188-125-2**APPENDIX A**

- l. Security (see A.4.9).
- m. Test schedule, including priority of measurements.

Data item description DI-NUOR-80928, “Nuclear Survivability Test Plan,” shall be used.

A.4.8 Test report requirements. A shielding effectiveness test report shall be prepared. As a minimum, the report shall contain the following information:

- a. System identification and a reference to the applicable test plan.
- b. A discussion of any deviations from the test plan or the requirements of this Appendix.
- c. Test calibration and measurement data. Figure A-3 illustrates a typical data graph.
- d. Pass/fail conclusions.

Data item description DI-NUOR-80929A, “Nuclear Survivability Test Report,” shall be used.

A.4.9 Data classification. Test data may be classified. DNA-EMP-1 and the security classification guide for the specific system should be consulted for guidance.

A.5 DETAILED REQUIREMENTS

A.5.1 Data requirements. For each test area (see A.4.7c) and test point (see A.4.7d), shielding effectiveness measurements shall be made at test frequencies from 10 kHz to 1 GHz and at transmitting and receiving antenna polarizations as follows:

a. Test frequencies - Test frequencies shall be spaced approximately logarithmically within each decade, with a minimum sampling density as follows:

- 10 kHz - 100 kHz : 20 test frequencies
- 100 kHz - 1 MHz : 20 test frequencies
- 1 MHz - 10 MHz : 40 test frequencies
- 10 MHz - 100 MHz : 150 test frequencies
- 100 MHz - 1 GHz : 150 test frequencies

MIL-STD-188-125-2

APPENDIX A

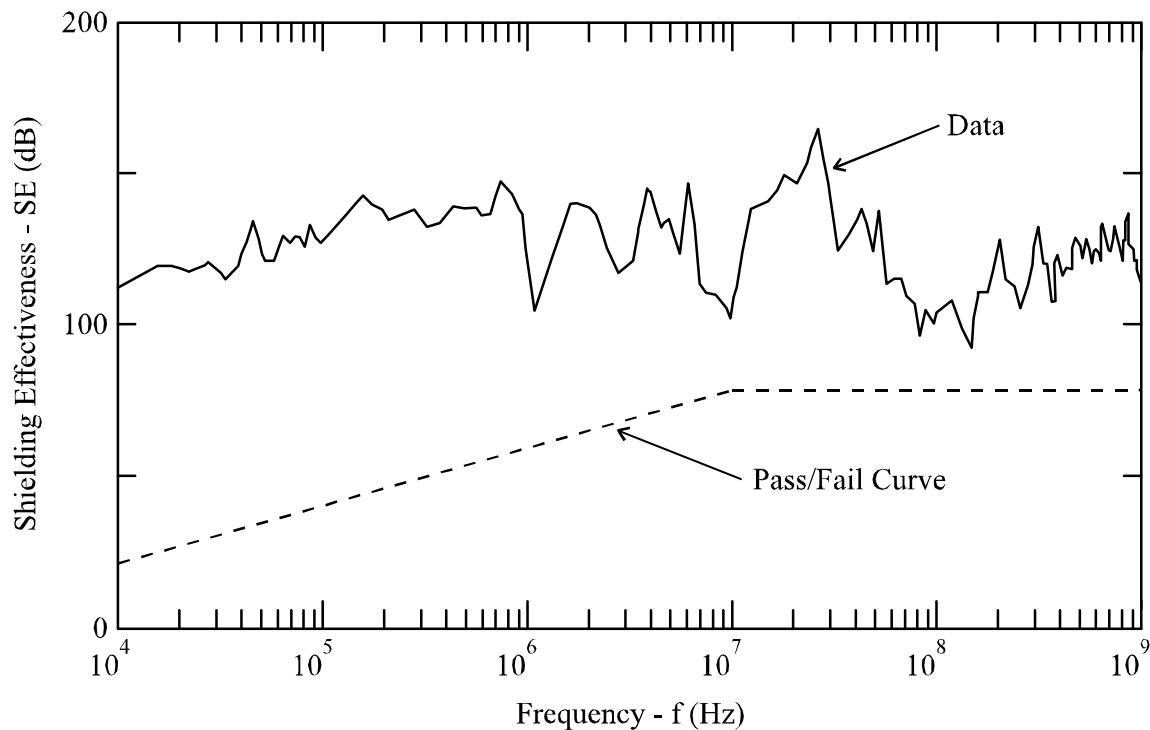

FIGURE A-3. Typical shielding effectiveness measurement record.

The spacing may be adjusted to avoid discrete system operating frequencies and noise spikes in the ambient electromagnetic environment.

b. Antenna polarizations - Measurements shall be made at two transmitting and receiving antenna polarizations as follows:

- Magnetic regime: The transmitting and receiving loop antennas shall be coplanar. Planes of the magnetic loop antennas shall be normal to the shield surface in two orientations, at 90 degrees to each other and parallel to the principal seams in the shield.
- Resonant range/plane wave regimes: Dipoles of the biconical and log periodic antennas shall be parallel to each other and to the shield surface in two orientations, at 90 degrees to each other and parallel to the principal seams in the shield.

MIL-STD-188-125-2

APPENDIX A

A.5.2 Calibration procedure. Calibrations at all test frequencies and at both antenna polarizations shall be performed as shown on figure A-4. The transmitting and receiving loop antennas shall be coplanar in the magnetic test regime, and the distance between antennas, measured between the centers of the loops, shall be 2.5 ± 0.05 m (8.2 ft \pm 2 in). In the resonant/plane wave test regimes, dipoles of the transmitting and receiving biconical and log periodic antennas shall be parallel to each other and the distance between antennas, measured between the feedpoint connections to the antenna elements, shall be 2.5 ± 0.05 m.

During the calibration sequence, no equipment or other electromagnetic reflectors (except ground) shall be closer to the antennas than three times the antenna separation. The antennas shall be at least 1.5 m (4.9 ft) above ground.

The instrumentation system shall be stepped through the test frequencies, and the received signal strength at each test frequency and polarization shall be recorded as the calibration signal (V_c) for that configuration. Frequency stepping may be interrupted as necessary to perform antenna and test equipment changes.

Instrumentation noise data shall also be acquired with the antennas in the calibration configurations. The instrumentation system shall be stepped through the test frequencies, with the power amplifiers deenergized. The received signal strength at each test frequency and polarization shall be recorded as the instrumentation noise signal (V_n) for that configuration. Frequency stepping may be interrupted as necessary to perform antenna and test equipment changes. The instrumentation dynamic range (DR) at each test frequency and polarization is defined as follows:

$$DR = 20 \log \left(\frac{V_c}{V_n} \right)$$

where corrections are applied for any differences in instrumentation system gain/attenuation between the calibration and instrumentation noise measurement configurations.

Test equipment shall be chosen to provide a dynamic range at least 20 dB in excess of the minimum shielding effectiveness requirement at every test frequency and antenna polarization.

A.5.3 Measurement procedure. Shielding effectiveness measurements for each test area and test point and at all test frequencies and both required antenna polarizations shall be

MIL-STD-188-125-2

APPENDIX A

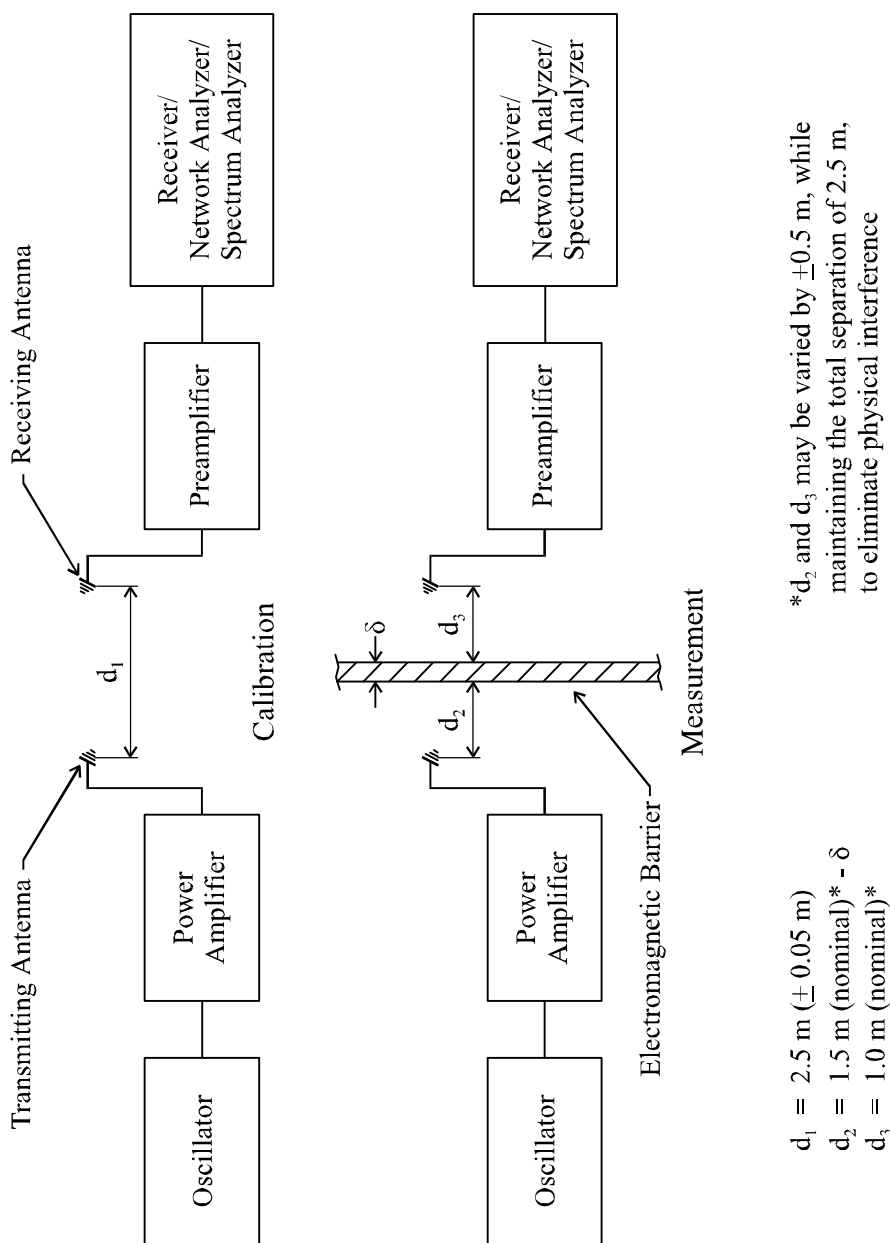

FIGURE A-4. Shielding effectiveness calibration and measurement configurations.

MIL-STD-188-125-2

APPENDIX A

performed as shown on figure A-4. Identical equipment, antennas, cables, and equipment settings (except gain/attenuator settings) shall be used in the calibration and measurement sequences.

The transmitting antenna should normally be placed outside the electromagnetic barrier, along the measurement axis centered on the test area (or test point). The receiving antenna shall be on the opposite side of the barrier and shall be centered on the test area (or test point). The loops of the transmitting and receiving loop antennas shall be coplanar in the magnetic test regime. Dipoles of the transmitting and receiving biconical and log periodic antennas shall be parallel to each other and parallel to the shield surface for the resonant range/plane wave measurements. The nominal distance from the transmitting antenna reference point (center of a loop antenna and feedpoint of a biconical or log periodic antenna) to the shield surface is 1.5 m (4.9 ft), less the thickness δ of the shield. The nominal distance from the receiving antenna reference point to the shield surface is 1 m (3.3 ft), and at least 0.3-m (1-ft) clearance between the shield and the closest active point on the antenna shall be maintained. The transmitting and receiving antenna distances from the shield may be varied by ± 0.5 m (1.6 ft), while maintaining the total separation of 2.5 m, to eliminate physical interference. The measurement axis may also be displaced from the center of the test area (or test point) to eliminate physical interference or maintain the receiving antenna clearance from the shield. These variations and displacements shall be noted in the test report.

The instrumentation system shall be stepped through the test frequencies, and the received signal strength at each test frequency and polarization shall be recorded as the measured signal (V_m) for that test area (or test point) and configuration. Frequency stepping may be interrupted as necessary to perform antenna and test equipment changes.

A.5.4 System ambient noise measurement procedure. System ambient noise measurements are not required, but are recommended at selected test areas (or test points) for characterizing the operating electromagnetic environment within the subsystem protected volume and for investigating below-specification readings. Ambient noise measurements at a test area (or test point) are made with the receiving antennas at the same locations and in the same orientations as those specified for shielding effectiveness measurements (see A.5.3). The instrumentation system shall be stepped through the test frequencies, with the power amplifiers deenergized. The received signal strength at each test frequency and polarization shall be recorded as the ambient noise signal (V_a) for that test area (or test point) and configuration. Frequency stepping may be interrupted as necessary to perform antenna and test equipment changes. The system measurement range (MR) at each test frequency and polarization is defined as follows:

MIL-STD-188-125-2**APPENDIX A**

$$MR = 20 \log \left(\frac{V_c}{V_a} \right)$$

where corrections are applied for any differences in instrumentation system gain/attenuation between the calibration and ambient noise measurement configurations.

When system ambient noise limits the measurement range significantly below the required dynamic range, the noise source should be eliminated if practical. Interference from narrow band ambient noise spikes can also be eliminated by adjusting the test frequency selection.

A.5.5 Pass/fail criteria⁸. The shielding effectiveness pass/fail criteria are shown as a function of frequency on figure A-5. The subsystem HEMP shield and aperture POE protective treatments shall be considered satisfactory when both of the following criteria are met:

- a. There is no series of measurements where the measured shielding effectiveness values are below the minimum requirements curve (figure A-5) at three consecutive frequencies.
- b. No more than 10 percent of the measured shielding effectiveness values in any decade (10 kHz - 100 kHz, 100 kHz - 1 MHz, 1 MHz - 10 MHz, 10 MHz - 100 MHz, and 100 MHz - 1 GHz) are below the minimum requirements curve (figure A-5).

When making the pass/fail determination, below-specification shielding effectiveness values can be disregarded if it can be demonstrated that the reading is due to an ambient noise source that cannot practically be eliminated.

A.5.6 Test failures. Any failure to satisfy the shielding effectiveness pass/fail criteria shall be considered a potential HEMP vulnerability. The cause of the potential vulnerability shall be investigated and corrected, if possible. After correction of the deficiency, the applicable portion of the shielding effectiveness test procedure shall be repeated.

⁸ For a test area (or test point) shielding effectiveness measurement taken inside a special protective volume, the pass/fail criteria are as specified for that special protective volume. Measurements in the adjacent protected volume are also required, to demonstrate that the total attenuation through the main barrier and special protective barrier satisfies the minimum requirement shown on figure A-5.

MIL-STD-188-125-2

APPENDIX A

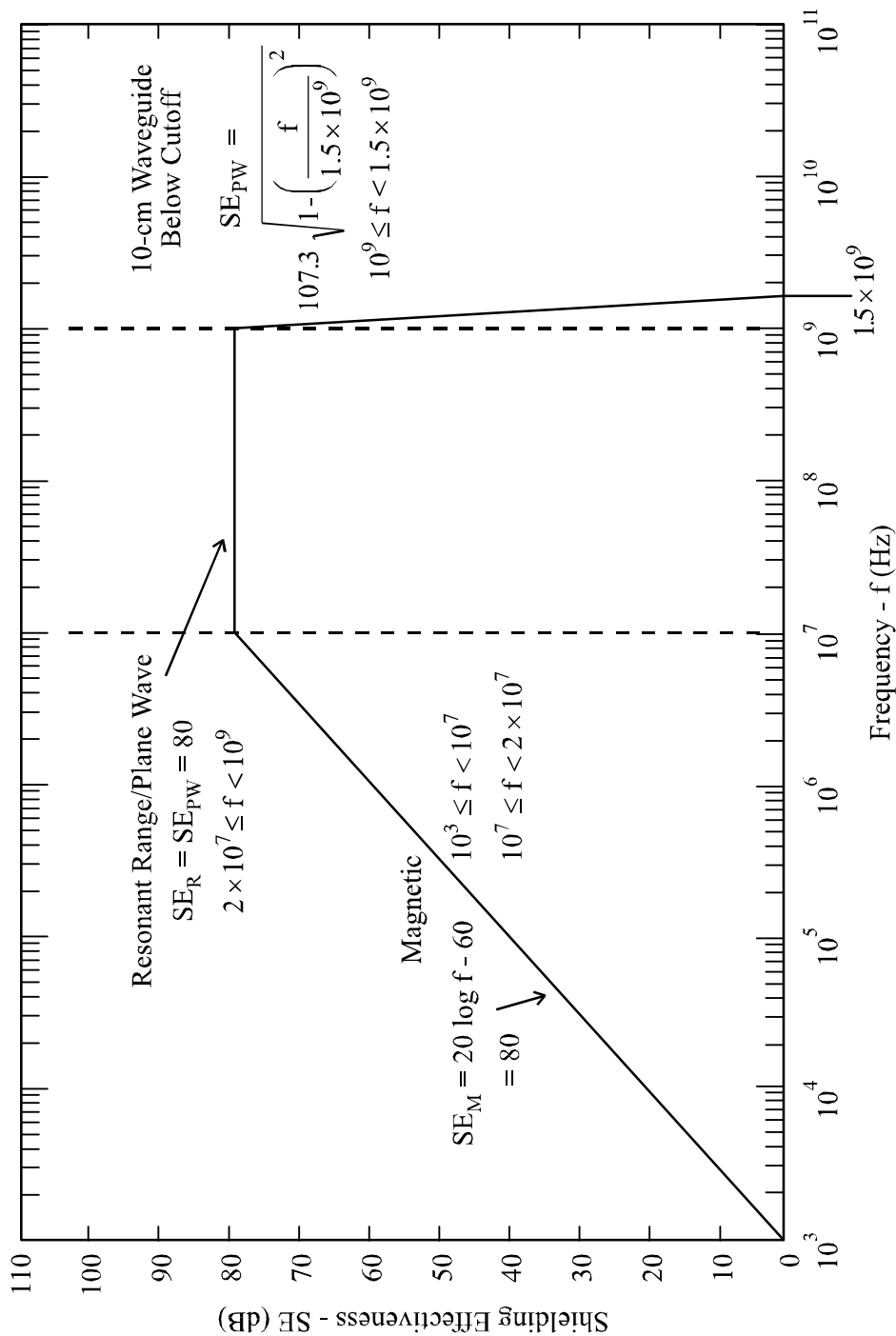

FIGURE A-5. Minimum HEMP shielding effectiveness requirements.

MIL-STD-188-125-2

APPENDIX B

PULSED CURRENT INJECTION (PCI) TEST PROCEDURES FOR TRANSPORTABLE GROUND-BASED SYSTEMS

B.1 GENERAL

B.1.1 Scope. This Appendix is a mandatory part of this standard. The information contained herein is intended for compliance. This Appendix establishes pulsed current injection test procedures for electrical point-of-entry (POE) protective devices and long-line protection modules (LLPMs) required for low-risk high-altitude electromagnetic pulse (HEMP) protection of transportable ground-based systems with critical, time-urgent missions. The procedures are applicable for testing other HEMP-hardened systems, when specified by the procurement documentation.

B.1.2 Applications. These procedures shall be used for PCI acceptance testing after installation of subsystem electrical POE protective treatments and LLPMs. The procedures shall also be performed for PCI verification testing of electrical POE protective devices and LLPMs after the system is completed and operational.

B.2 REFERENCED DOCUMENTS

B.2.1 Government documents. The following Government documents form a part of this Appendix to the extent specified:

MIL-STD-2169	–	High-Altitude Electromagnetic Pulse (HEMP) Environment (U) (document is classified Secret)
MIL-HDBK-423	–	High-Altitude Electromagnetic Pulse (HEMP) Protection for Fixed and Transportable Ground-Based Facilities, Volume I: Fixed Facilities
DI-NUOR-80928	–	Nuclear Survivability Test Plan
DI-NUOR-80929A	–	Nuclear Survivability Test Report
DNA-EMP-1	–	Electromagnetic Pulse (EMP) Security Classification Guide (U) (document is classified S-RD)

(Copies of documents required by contractors in connection with specific acquisition functions should be obtained from the contracting activity or as directed by the contracting officer.)

MIL-STD-188-125-2**APPENDIX B**

B.2.2 Non-Government publications. The following publication forms a part of this Appendix to the extent specified:

IEEE-Std-488.1 – Standard Digital Interface for Programmable Instrumentation

(Applications for copies should be addressed to the Institute for Electrical and Electronics Engineers [IEEE], 445 Hoes Lane, Post Office Box 1331, Piscataway, NJ 08855-1331.)

B.3 DEFINITIONS

B.3.1 Norms. Scalar quantities that characterize the features of a complicated waveform. Norms used as pass/fail criteria for PCI test residual stresses are peak current, peak rate of rise, and root action. These quantities apply to the short pulse tests and long pulse tests only.

B.3.2 Peak current norm. The maximum absolute value of the amplitude of a current waveform $I(t)$, expressed in units of amperes and measured from time $t = 0$ to $t = 5 \times 10^{-3}$ seconds for the short pulse and from $t = 0$ to $t = 100$ seconds for the long pulse, where $t = 0$ at the start of the PCI drive.

B.3.3 Peak rate of rise norm. The maximum absolute value of the first derivative with respect to time, dI/dt , of a current waveform, expressed in units of amperes per second and measured from time $t = 0$ to $t = 5 \times 10^{-3}$ seconds for the short pulse and from $t = 0$ to $t = 100$ seconds for the long pulse, where $t = 0$ at the start of the PCI drive.

B.3.4 Root action norm. The root action norm of a current waveform $I(t)$, in units of amperes - $\sqrt{\text{seconds}}$, is defined by the equation:

$$\text{Root Action} = \sqrt{\int_0^t I^2(t) dt}$$

where $t = 0$ at the start of the PCI drive pulse. τ equals 5×10^{-3} seconds for the short pulse and 100 seconds for the long pulse.

MIL-STD-188-125-2

APPENDIX B

B.4 GENERAL REQUIREMENTS

B.4.1 General. PCI acceptance testing is performed to demonstrate that electrical POE protective devices and LLPMs, as installed, perform in accordance with the transient suppression/attenuation requirements of this standard. PCI verification testing confirms the transient suppression/attenuation performance in operational circuit configurations and demonstrates that the mission-critical equipment (MCE) do not experience mission-aborting damage or upsets as the result of the residual transient stresses.

This test method, for POE protective devices, couples threat-relatable transients to penetrating conductors at injection points outside the electromagnetic barrier. Injections are required in both common mode (all penetrating conductors of a cable simultaneously driven with respect to ground) and individual wire-to-ground configurations. For purposes of this procedure, ground is a point on the subsystem HEMP shield in the vicinity of the POE protective device under test. Residual internal transient stresses are measured and, during a verification test, operation of the MCE is monitored to determine if mission-aborting damage or upsets occur.

The required PCI tests are performed on each penetrating power line, control/signal/data cable and conductor, and radio frequency (RF) antenna cable core conductor and shield. Simultaneous injection of all subsystem electrical POE protective devices, if practical, is desirable for verification testing. The PCI tests are also conducted on long-lines into each LLPM to demonstrate that the LLPM adequately isolates the intrasite cable plant from the reasonable worst case long-line transients.

B.4.2 Purpose.

B.4.2.1 Purposes of PCI acceptance testing. The purposes of PCI testing, as an acceptance test procedure, are as follows:

- a. To measure the performance of as-installed conductive POE protective devices and LLPMs.
- b. To demonstrate through post-test inspection, performance checks, and response data analysis that the protective devices will not be damaged or unacceptably degraded by threat-relatable transients.
- c. To identify defective POE protective devices or LLPMs and faulty installation practices, so that repairs or replacements can be made.

MIL-STD-188-125-2

APPENDIX B

B.4.2.2 Purposes of PCI verification testing. The purposes of PCI testing, as part of a verification test program, are as follows:

- a. To measure the performance of as-installed conductive POE protective devices and LLPMs.
- b. To demonstrate through post-test inspection, performance checks, and response data analysis that the protective devices will not be damaged or unacceptably degraded by threat-relatable transients.
- c. To identify defective POE protective devices or LLPMs and faulty installation practices, so that repairs or replacements can be made.
- d. To characterize the residual transient stresses.
- e. To demonstrate that the residual transient stresses will not cause mission-aborting damage or upsets of the MCE in its various operating states.
- f. To provide data for HEMP hardness assessment of the transportable system and baseline data for the harness maintenance/hardness surveillance program.

B.4.3 Subsystem HEMP protection test configuration.

B.4.3.1 Acceptance test configuration. PCI testing for acceptance is performed after the POE protective devices have been installed in the subsystems and after the LLPMs have been completed. The electromagnetic barrier is not required to be complete, but it must be recognized that an incomplete barrier may result in degradations of POE protective device performance and the instrumentation system signal-to-noise ratio (SNR). Equipment that, in subsystem operation, will electrically connect to the POE protective device or LLPM under test are not required to be installed or powered.

B.4.3.2 Verification test configuration. When PCI verification testing is conducted, the subsystem under test shall be in a normal operating configuration and shall be performing actual or simulated mission functions. The subsystem HEMP protection shall be intact. Equipment that electrically connects to the POE protective device or LLPM under test shall be powered and operating, except as otherwise specified in this procedure.

B.4.4 Pretest analysis requirements. No pretest analyses are required for PCI acceptance testing. Pretest analysis for PCI verification testing shall be performed to determine operating states in which the MCE will be tested. An equipment should be tested in multiple states when

MIL-STD-188-125-2

APPENDIX B

the transition between states produces significantly different propagation paths for the residual transient, significant changes in the equipment vulnerability threshold, or significant changes in the function being performed. A mission-critical transceiver should be tested in the transmitting and receiving states, for example, and a digital interface should be tested in both the low and high signal states.

B.4.5 Test equipment requirements. Test equipment required for PCI testing are identified in tables B-I and B-II. Table B-I lists the equipment required for testing electrical POE protective devices. The equipment required for testing LLPMs are listed in table B-II. Current injection pulse generators are defined by their Norton equivalent circuits. Therefore, pulse generator requirements are stated in terms of the short-circuit current amplitude and waveform parameters and the source impedance. Short-circuit current is defined as current driven through a short-circuit calibration load connected to the generator output terminals. Source impedance is defined as the pulse generator peak open-circuit voltage divided by the peak short-circuit current.

B.4.6 Operational impact analysis and risk.

B.4.6.1 Acceptance testing impact When PCI testing is performed as an acceptance test procedure, the electromagnetic barrier must remain reasonably intact, such that POE protective device performance and instrumentation SNR ratio are not excessively degraded. The use of electrically noisy equipment must be restricted in order to achieve the required measurement sensitivity. Manufacturing activity in the area or unusual operations, such as modifications or maintenance, may therefore be affected.

B.4.6.2 Verification testing impact. During PCI verification testing, the electromagnetic barrier must remain intact and use of electrically noisy equipment, which is not part of the operational equipment suite, must be restricted in order to achieve the required measurement sensitivity. Manufacturing activity in the area or unusual operations, such as modifications or maintenance, may therefore be affected. Mission operations can continue normally, except as follows:

a. The circuit and POE protective device or LLPM under test may be unavailable for normal use. It may be necessary to disconnect unprotected equipment outside the barrier, and the circuit may be periodically deenergized.

b. A special sequence of activities may be required so that the circuits and system can be tested in their various operating states.

MIL-STD-188-125-2

APPENDIX B

TABLE B-I. PCI equipment requirements for POE protective device testing.

Equipment	Characteristics		
	Short Pulse ¹	Intermediate Pulse ¹	Charge Line Pulser (for RF antenna signal conductors) ¹
Pulse Generators	≥ 1-kA short-circuit current; double-exponential waveform; source impedance ≥ 60 Ω	≥ 250-A short-circuit current; double-exponential waveform; source impedance ≥ 10 Ω	≥ 400-A short-circuit current; source impedance ≥ 50 Ω; variable pulse width
Current Sensors (Injected Transient)	10 kHz - 750 MHz; 0 - 1 kA	dc - 10 MHz; 0 - 250 A	10 kHz-750 MHz; 0 - 400 A
Current Sensors (Residual Transient)	100 Hz - 750 MHz; 0 - 100 A; transfer impedance as required for measurement sensitivity	dc - 10 MHz; 0 - 250 A	100 Hz - 750 MHz; 0 - 100 A; transfer impedance as required for measurement sensitivity
Oscilloscopes or Transient Digitizers	100 Hz - 750 MHz; minimum sensitivity as required for measurement sensitivity	dc - 10 MHz	100 Hz - 750 MHz; minimum sensitivity as required for measurement sensitivity
Data Recorder	0 - 5 ms	0 - 50 ms	0 - 5 ms
Preamplifiers	100 Hz - 750 MHz; amplification and noise figure as required for measurement sensitivity	-	100 Hz - 750 MHz; amplification and noise figure as required for measurement sensitivity
Computer and GPIB Control Interfaces ²	As required	As required	As required
Instrumentation Shield and Power Supplies	As required for isolation from pulse generator	As required for isolation from pulse generator	As required for isolation from pulse generator
Miscellaneous Cables, Attenuators, and Dummy Load Resistors	As required	As required	As required

¹ See Table B-III for other characteristics of the short, intermediate, and charge line pulses. The method of coupling the pulse generator output to the penetrating conductor is not specified. However, connection of the pulse generator into the circuit under test must not interfere with normal circuit operation.

² Use of a personal computer with an IEEE-488 general purpose interface bus (GPIB), or equivalent, to control instrumentation and store test data is strongly recommended.

MIL-STD-188-125-2

APPENDIX B

TABLE B-II. PCI equipment requirements for LLPM testing.

Equipment	Characteristics		
	Short Pulse ¹	Intermediate Pulse ¹	Long Pulse ^{1,2}
Pulse Generators	≥ 5-kA short-circuit current; double-exponential waveform; source impedance ≥ 60 Ω	≥ 250-A short-circuit current; double-exponential waveform; source impedance ≥ 10 Ω	≥ 1-kA short-circuit current; double-exponential waveform; source impedance ≥ 5 Ω
Current Sensors (Injected Transient)	10 kHz - 750 MHz; 0 - 5 kA	dc - 10 MHz; 0 - 250 A	dc - 10 kHz; 0 - 1 kA
Current Sensors (Residual Transient)	100 Hz - 750 MHz; 0 - 5 kA	dc - 10 MHz; 0 - 250 A	dc - 10 kHz; 0 - 1 kA
Oscilloscopes or Transient Digitizers	100 Hz - 750 MHz; minimum sensitivity as required for measurement sensitivity	dc - 10 MHz	dc - 10 kHz
Data Recorder	0 - 5 ms	0 - 50 ms	0 - 100 s
Preamplifiers	100 Hz - 750 MHz; amplification and noise figure as required for measurement sensitivity	-	-
Computer and GPIB Control Interfaces ³	As required	As required	As required
Instrumentation Shield and Power Supplies	As required for isolation from pulse generator	As required for isolation from pulse generator	As required for isolation from pulse generator
Miscellaneous Cables, Attenuators, and Dummy Load Resistors	As required	As required	As required

¹ See Table B-IV for other characteristics of the short, intermediate, and long pulses. The method of coupling the pulse generator output to the long-line conductor is not specified. However, connection of the pulse generator into the circuit under test must not interfere with normal circuit operation.

² 1-kA short-circuit capability is a design objective. See Table B-IV for the minimum requirement.

³ Use of a personal computer with an IEEE-488 general purpose interface bus (GPIB), or equivalent, to control instrumentation and store test data is strongly recommended.

MIL-STD-188-125-2

APPENDIX B

B.4.6.3 Risk. PCI testing requires application of high voltages and large currents. Because of the high injection levels, the risk of damage to POE protective devices or other equipment cannot be completely eliminated. However, the procedures are designed to minimize this risk. Special high-voltage electrical safety precautions are required. As required, radio frequency radiation protection shall be provided for test personnel.

B.4.7 Test plan and procedures.

B.4.7.1 Acceptance test plan and procedures. A comprehensive, system-specific test plan and detailed test procedures for PCI acceptance testing shall be prepared. These may be combined in a single document, or two separate documents may be used. As a minimum, the documentation shall contain the following information:

- a. A statement of test objectives.
- b. System, subsystem, and LLPM identification and descriptions (including drawings of the subsystems showing the locations of all POEs, circuit diagrams of LLPMs that interface to the subsystems under test, and a description of the HEMP protection measures).
- c. Identification of the circuits and protective devices to be tested (including circuit functions and manufacturers' data sheets and specifications for the protective devices).
- d. HEMP simulation and data acquisition equipment descriptions (including manufacturer, model and serial numbers, characteristics, and detailed calibration procedures).
- e. Identification of POE protective device injection points, injection levels and waveforms (see table B-III), and measurement points.
- f. Identification of LLPM injection points, injection levels and waveforms (see table B-IV), and measurement points.
- g. Detailed test procedures.
- h. Any deviations from the requirements of this Appendix.
- i. Data management (including data quality control procedures, data acceptability criteria, annotation and preservation of data records, and pass/fail criteria).
- j. Safety, including electromagnetic radiation and electrical shock hazards.

MIL-STD-188-125-2

APPENDIX B

TABLE B-III. PCI source parameters, waveforms, and acceptance test loads for electrical POE testing.

a. Electrical POEs, except RF antenna line POEs.

Class of Electrical POE/ Type of Injection ¹	Peak Short- Circuit Current (A)	Source Impedance (ohms)	Risetime (s)	FWHM (s)	Acceptance Test Resistance (ohms)
Intrasite power line POEs					
Short pulse common mode ²	1,000	≥ 60	≤ 2×10 ⁻⁸	5×10 ⁻⁷ - 5.5×10 ⁻⁷	Not applicable
Short pulse wire-to-ground ³	500	≥ 60	≤ 2×10 ⁻⁸	5×10 ⁻⁷ - 5.5×10 ⁻⁷	⁴ 2 or V _{rated} /I _{rated}
Intermediate pulse common mode ^{2,5}	250	≥ 10	≤ 1.5×10 ⁻⁶	3×10 ⁻³ - 5×10 ⁻³	Not applicable
Intermediate pulse wire-to-ground ^{3,5}	250	≥ 10	≤ 1.5×10 ⁻⁶	3×10 ⁻³ - 5×10 ⁻³	50
Intrasite control/signal/data line POEs					
Short pulse common mode ²	1,000	≥ 60	≤ 2×10 ⁻⁸	5×10 ⁻⁷ - 5.5×10 ⁻⁷	Not applicable
Short pulse wire-to-ground ³	⁶ 1,000/√N or 100	≥ 60	≤ 2×10 ⁻⁸	5×10 ⁻⁷ - 5.5×10 ⁻⁷	⁴ 2 or V _{rated} /I _{rated}
Intermediate pulse common mode ^{2,5}	250	≥ 10	≤ 1.5×10 ⁻⁶	3×10 ⁻³ - 5×10 ⁻³	Not applicable
Intermediate pulse wire-to-ground ^{3,5,7}	250	≥ 10	≤ 1.5×10 ⁻⁶	3×10 ⁻³ - 5×10 ⁻³	50

MIL-STD-188-125-2

APPENDIX B

TABLE B-III. PCI source parameters, waveforms, and acceptance test loads for electrical POE testing - Continued.

b. RF antenna line POEs.

Class of Electrical POE/ Type of Injection ¹	Dominant Response Frequency (MHz)	Peak Short- Circuit Current (A)	Source Impedance (ohms)	Risetime (s)	FWHM (s)	Acceptance Test Resistance (ohms)
RF antenna line shield conductors						
Buried ⁸						
Short pulse shield-to-ground ⁹	Not Applicable	800	≥ 60	≤ 2×10 ⁻⁸	5×10 ⁻⁷ -5.5×10 ⁻⁷	¹⁰ Z _T
Nonburied intrasite ⁸						
Short pulse shield-to-ground ⁹	Not Applicable	1,000	≥ 60	≤ 2×10 ⁻⁸	5×10 ⁻⁷ -5.5×10 ⁻⁷	¹⁰ Z _T
Nonburied long line ⁸						
Short pulse shield-to-ground ⁹	Not Applicable	5,000	≥ 60	≤ 2×10 ⁻⁸	5×10 ⁻⁷ -5.5×10 ⁻⁷	¹⁰ Z _T
RF antenna line core conductors						
Short pulse core wire-to-shield	¹¹ ≤ 30	Threat level ¹¹	≥ 60	≤ 2×10 ⁻⁸	5×10 ⁻⁷ -5.5×10 ⁻⁷	¹⁰ Z _T
Short pulse core wire-to-shield	¹¹ > 30	Threat level ^{11,12}	≥ 50	≤ 5×10 ⁻⁹	Variable ¹¹	¹⁰ Z _T

MIL-STD-188-125-2

APPENDIX B

TABLE B-III. PCI source parameters, waveforms, and acceptance test loads for electrical POE testing - Continued.

c. Notes.

¹ Pulsed current injection requirements are defined in terms of the Norton equivalent sources. Double-exponential waveforms (figure B-1) are used in all POE PCI tests, except for RF antenna line core wire-to-shield tests at dominant response frequencies > 30 MHz and peak short-circuit currents within the capability of the charge line pulser. For these exceptions, the core wire-to-shield injection uses the output waveform of the charge line pulser, with the length of the charge line equal to the quarter-wavelength at the applicable dominant response frequency. Peak short-circuit current is the peak time-domain current into a short-circuit calibration load at the pulser output terminals. Source impedance is the pulser peak time-domain open-circuit voltage divided by the peak time-domain short-circuit current. Risettime τ_R is the 10-percent to 90-percent risetime. Full-width at half-maximum amplitude (FWHM) is the time interval between the 50-percent amplitude points.

The source parameters are generally specified by the minimum acceptable source impedance and the maximum acceptable risetime. This is done for the sole purpose of experimental practicality, so that the current injection sources are not required to precisely match prescribed waveforms.

² For a common mode test, all conductors in the cable are simultaneously driven with respect to ground, where ground is a point on the subsystem HEMP shield in the vicinity of the POE protective device under test. Common mode testing is required for verification, but is not required for acceptance.

³ For a wire-to-ground test, each of the conductors in the cable is individually driven with respect to ground, where ground is a point on the subsystem HEMP shield in the vicinity of the POE protective device under test.

⁴ V_{rated} and I_{rated} are the maximum voltage and current ratings of the POE protective device, respectively. The smaller of these two resistances is required.

MIL-STD-188-125-2

APPENDIX B

TABLE B-III. PCI source parameters, waveforms, and acceptance test loads for electrical POE testing - Continued.

c. Notes (continued).

- ⁵ Intermediate pulse current injection tests are required only on those intrasite electrical POE protective devices that may sometimes be connected to an LLP. If the associated LLP is available for testing, the intermediate pulse current shall be injected at the long-line terminal of the LLP. The current shall be injected at the external terminal of the POE protective device when the LLP cannot be provided for testing.
- ⁶ N is the number of conductors in the cable. The larger of these two amplitudes is required.
- ⁷ Intermediate pulse wire-to-ground tests of control/signal/data line POEs are required for acceptance, but they are not required for verification.
- ⁸ An antenna shield is considered buried when it terminates at a buried antenna and < 1 m (3.3 ft) of its total length is not covered by earth or concrete. If either of these conditions is not satisfied, the antenna shield is considered nonburied.
- ⁹ For a shield-to-ground test, maximum feasible length of the antenna line shield is driven with respect to ground, where ground is a point on the subsystem HEMP shield in the vicinity of the POE protective device under test.
- ¹⁰ The core conductor is terminated to the cable shield in a dummy load with resistance equal to the characteristic impedance of the interior RF transmission line. The shield is electrically terminated in a short circuit to the installed equipment or to the subsystem HEMP shield near the POE.
- ¹¹ The dominant response frequency (or frequencies) and threat-level peak short-circuit current are determined from extrapolated coupling measurements (see B.5.2.1).
- ¹² If the PCI short-circuit current requirement exceeds the capability of the charge line pulser, the short pulse double-exponential pulser shall be used instead of the charge line pulser.

MIL-STD-188-125-2

APPENDIX B

TABLE B-IV. PCI source parameters, waveforms, and acceptance test loads for LLPm testing.

Class of LLPm/ Type of Injection ¹	Peak Short-Circuit Current (A)	Source Impedance (ohms)	Risetime (s)	FWHM (s)	Acceptance Test Resistance (ohms)
Power line LLPms					
Short pulse common mode ²	5,000	≥ 60	≤ 2×10 ⁻⁸	5×10 ⁻⁷ - 5.5×10 ⁻⁷	Not applicable
Short pulse wire-to-ground ³	2,500	≥ 60	≤ 2×10 ⁻⁸	5×10 ⁻⁷ - 5.5×10 ⁻⁷	2
Intermediate pulse common mode ²	250	≥ 10	≤ 1.5×10 ⁻⁶	3×10 ⁻³ - 5×10 ⁻³	Not applicable
Intermediate pulse wire-to-ground ³	250	≥ 10	≤ 1.5×10 ⁻⁶	3×10 ⁻³ - 5×10 ⁻³	50
Long pulse common mode ²	⁴ 1,000	≥ 5	≤ 0.2	⁴ 20-25	Not applicable
Long pulse wire-to-ground ³	⁴ 1,000	≥ 5	≤ 0.2	⁴ 20-25	50
Control/signal/data line LLPms					
Short pulse common mode ²	5,000	≥ 60	≤ 2×10 ⁻⁸	5×10 ⁻⁷ - 5.5×10 ⁻⁷	Not applicable
Short pulse wire-to-ground ³	⁵ 5,000/√N or 500	≥ 60	≤ 2×10 ⁻⁸	5×10 ⁻⁷ - 5.5×10 ⁻⁷	50
Intermediate pulse common mode ²	250	≥ 10	≤ 1.5×10 ⁻⁶	3×10 ⁻³ - 5×10 ⁻³	Not applicable
Intermediate pulse wire-to-ground ³	250	≥ 10	≤ 1.5×10 ⁻⁶	3×10 ⁻³ - 5×10 ⁻³	50
Long pulse common mode ²	⁴ 1,000	≥ 5	≤ 0.2	⁴ 20-25	Not applicable
Long pulse wire-to-ground ³	⁴ 1,000	≥ 5	≤ 0.2	⁴ 20-25	50

MIL-STD-188-125-2

APPENDIX B

TABLE B-IV. PCI source parameters, waveforms, and acceptance test loads for LLPM testing - Continued.

Notes.

¹ Pulsed current injection requirements are defined in terms of the Norton equivalent sources. Double-exponential waveforms (figure B-1) are used in all LLPM PCI tests. Peak short-circuit current is the peak time-domain current into a short-circuit calibration load at the pulser output terminals. Source impedance is the pulser peak time-domain open-circuit voltage divided by the peak time-domain short-circuit current. Risettime τ_R is the 10-percent to 90-percent risetime. Full-width at half-maximum amplitude (FWHM) is the time interval between the 50-percent amplitude points.

The source parameters are generally specified by the minimum acceptable source impedance and the maximum acceptable risetime. This is done for the sole purpose of experimental practicality, so that the current injection sources are not required to precisely match prescribed waveforms.

- ² For a common mode test, all conductors in the cable are simultaneously driven with respect to the LLPM ground connection point. Common mode testing is required for verification, but is not required for acceptance.
- ³ For a wire-to-ground test, each of the conductors in the cable is individually driven with respect to the LLPM ground connection point.
- ⁴ The long pulse peak short-circuit current (1,000 A) and FWHM (20-25 s) are design objectives. Any double-exponential waveform with a peak amplitude ≥ 200 A, risetime ≤ 0.2 s, and peak current \times FWHM product $\geq 2 \times 10^4$ A-s satisfies the minimum requirement.
- ⁵ N is the number of conductors in the cable. The larger of these two amplitudes is required.

MIL-STD-188-125-2

APPENDIX B

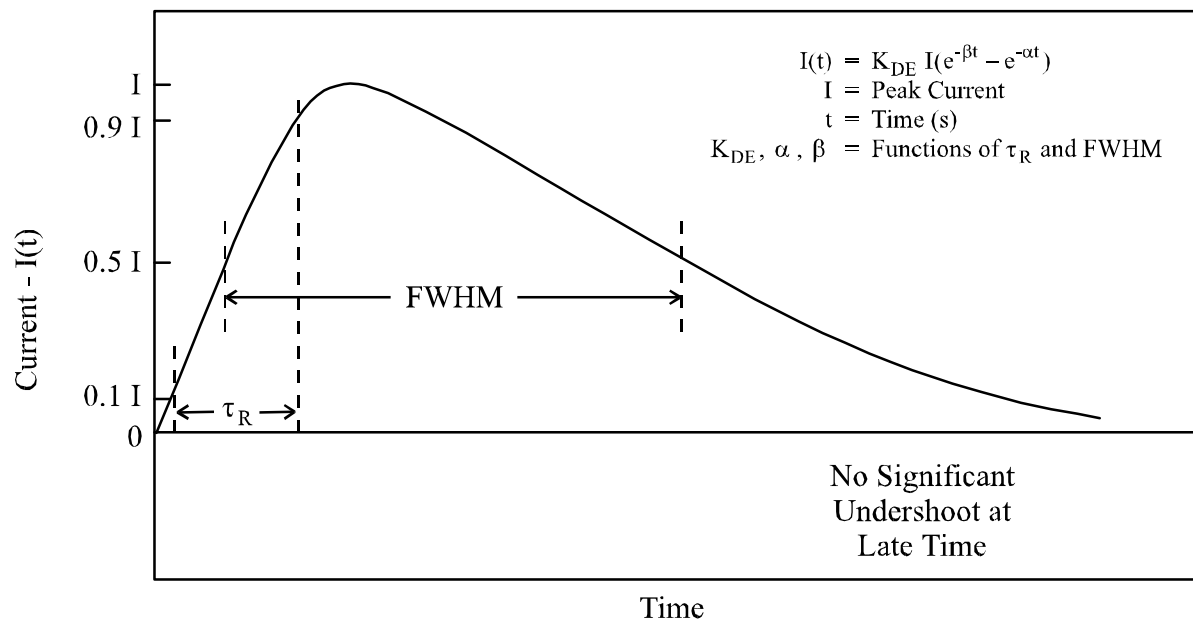
FIGURE B-1. Double exponential waveform.

- k. Security (see B.4.10).
- l. Test schedule, including priority of measurements.

Data item description DI-NUOR-80928, "Nuclear Survivability Test Plan," shall be used.

B.4.7.2 Verification test plan and procedures. A comprehensive, system-specific test plan and detailed test procedures for PCI verification testing shall be prepared. These may be combined in a single document, or two separate documents may be used. As a minimum, the documentation shall contain the following information:

- a. A statement of test objectives.
- b. System, subsystem, and LLPM identification and descriptions (including drawings of the subsystems showing the locations of all POEs, equipment layout inside the electromagnetic barrier, and external cable interconnections; circuit diagrams of LLPMs that interface to the subsystem under test; and a description of the HEMP protection measures).

MIL-STD-188-125-2

APPENDIX B

- c. Identification of the circuits and protective devices to be tested (including circuit functions and manufacturers' data sheets and specifications for the protective devices).
- d. HEMP simulation and data acquisition equipment descriptions (including manufacturer, model and serial numbers, characteristics, and detailed calibration procedures).
- e. Identification of POE protective device injection points, injection levels and waveforms (see table B-III), and measurement points.
- f. Identification of LLPM injection points, injection levels and waveforms (see table B-IV), and measurement points.
- g. Detailed test procedures.
- h. Any deviations from the requirements of this Appendix.
- i. Data management (including data quality control procedures, data acceptability criteria, annotation and preservation of data records, and pass/fail criteria).
- j. Safety, including electromagnetic radiation and electrical shock hazards.
- k. Security (see B.4.10).
- l. Test schedule, including priority of measurements.

Data item description DI-NUOR-80928, "Nuclear Survivability Test Plan," shall be used.

B.4.8 Test report requirements.

B.4.8.1 Acceptance test report. A PCI acceptance test report shall be prepared. As a minimum, the report shall contain the following information:

- a. System identification and a reference to the applicable test plan.
- b. A discussion of any deviations from the test plan or the requirements of this Appendix.
- c. Copies of the measured results, along with sensor calibrations and instrumentation settings required to convert the data to engineering units. If the data are collected and processed with an automated data acquisition system and a complete set of data will be delivered in electronic format, samples of the processed data may be provided in the report.

MIL-STD-188-125-2

APPENDIX B

d. A summary table of the norms of the measured residual internal transient stresses, with comparisons to the maximum allowable residual response characteristics (see tables B-V and B-VI).

e. Pass/fail conclusions.

Data item description DI-NUOR-80929A, "Nuclear Survivability Test Report," shall be used.

B.4.8.2 Verification test report. A PCI verification test report shall be prepared. As a minimum, the report shall contain the following information:

a. System identification and a reference to the applicable test plan.

b. A discussion of any deviations from the test plan or the requirements of this Appendix.

c. Copies of the measured results, along with sensor calibrations and instrumentation settings required to convert the data to engineering units. If the data are collected and processed with an automated data acquisition system and a complete set of data will be delivered in electronic format, samples of the processed data may be provided in the report.

d. A summary table of the norms of the measured residual internal transient stresses, with comparisons to the maximum allowable residual response characteristics (see tables B-V and B-VI).

e. Test chronology (including a sequence of events; identification of failures, upsets, or interference observed and the conditions under which they occurred; findings from investigation into the causes of test failures, if any; and corrective actions and retest results).

f. Test conclusions including a definitive statement of the HEMP hardness of the system and subsystem mission functions, based on the results of the complete battery of verification tests and the supporting analysis.

Data item description DI-NUOR-80929A, "Nuclear Survivability Test Report," shall be used.

MIL-STD-188-125-2

APPENDIX B

TABLE B-V. Maximum allowable residual internal response norms for electrical POE Testing.

a. Electrical POEs, except RF antenna line POEs.

Class of Electrical POE/ Type of Injection	Type of Measurement	Peak Current (A)	Peak Rate of Rise (A/s)	Root Action (A \sqrt{s})
Intrasite power line POEs				
Short pulse common mode	Bulk current	≤ 10	$\leq 1 \times 10^7$	$\leq 1.6 \times 10^{-1}$
Short pulse wire-to-ground	Wire current	≤ 10	$\leq 1 \times 10^7$	$\leq 1.6 \times 10^{-1}$
Intermediate pulse common mode	Bulk current		No damage or performance degradation ¹	
Intermediate pulse wire-to-ground	Wire current		No damage or performance degradation ¹	
Intrasite control/signal/data line POEs				
Low-voltage lines ²				
Short pulse common mode	Bulk current	≤ 0.1	$\leq 1 \times 10^7$	$\leq 1.6 \times 10^{-3}$
Short pulse wire-to-ground	Wire current	≤ 0.1	$\leq 1 \times 10^7$	$\leq 1.6 \times 10^{-3}$
Intermediate pulse common mode	Bulk current		No damage or performance degradation ¹	
Intermediate pulse wire-to-ground	Wire current		No damage or performance degradation ¹	
High-voltage lines ²				
Short pulse common mode	Bulk current	≤ 1.0	$\leq 1 \times 10^7$	$\leq 1.6 \times 10^{-2}$
Short pulse wire-to-ground	Wire current	≤ 1.0	$\leq 1 \times 10^7$	$\leq 1.6 \times 10^{-2}$
Intermediate pulse common mode	Bulk current		No damage or performance degradation ¹	
Intermediate pulse wire-to-ground	Wire current		No damage or performance degradation ¹	

MIL-STD-188-125-2

APPENDIX B

TABLE B-V. Maximum allowable residual internal response norms for electrical POE testing - Continued.

b. RF antenna line POEs.

Class of Electrical POE/ Type of Injection	Type of Measurement	Peak Current (A)	Peak Rate of Rise (A/s)	Root Action (A \sqrt{s})
RF antenna line POEs				
Shield conductors				
Short pulse shield-to-ground	Shield current	≤ 0.1	$\leq 1 \times 10^7$	$\leq 1.6 \times 10^{-3}$
Short pulse core wire-to-shield	Shield current	≤ 0.1	$\leq 1 \times 10^7$	$\leq 1.6 \times 10^{-3}$
Core conductors (receive only)				
Short pulse shield-to-ground	Wire current	≤ 0.1	No damage or performance degradation ¹	
Short pulse core wire-to-shield	Wire current	≤ 0.1	No damage or performance degradation ¹	
Core conductors (transmit or transceive)				
Short pulse shield-to-ground	Wire current	≤ 1.0	No damage or performance degradation ¹	
Short pulse core wire-to-shield	Wire current	≤ 1.0	No damage or performance degradation ¹	

MIL-STD-188-125-2**APPENDIX B****TABLE B-V. Maximum allowable residual internal response norms for electrical POE testing - Continued.****c. Notes.**

¹ Pass/fail criteria on the residual internal response norms are not specified for the intermediate pulse current injection test sequence. Pass/fail criteria on the residual internal response peak rate of rise and root action norms on RF antenna line core conductors are not specified for the short pulse shield-to-ground and core wire-to-shield current injection test sequences. The pass/fail criteria of no POE protective device damage or performance degradation also applies to PCI test sequences where this note does not appear in the table.

² Low-voltage control/signal/data lines are those with maximum operating voltage < 90 V. High-voltage lines are those with a maximum operating voltage ≥ 90 V.

MIL-STD-188-125-2

APPENDIX B

TABLE B-VI. Maximum allowable residual response norms for LLPM testing.

Class of LLPM/ Type of Injection	Type of Measurement	Peak Current (A)	Peak Rate of Rise (A/s)	Root Action ($A \cdot \sqrt{s}$)
Power line LLPMs				
Short pulse common mode	Bulk current	≤ 500	$\leq 2.5 \times 10^{10}$	$\leq 3.1 \times 10^{-1}$
Short pulse wire-to-ground	Wire current	≤ 250	$\leq 1.3 \times 10^{10}$	$\leq 1.6 \times 10^{-1}$
Intermediate pulse common mode	Bulk current	No damage or performance degradation ¹		
Intermediate pulse wire-to-ground	Wire current	No damage or performance degradation ¹		
Long pulse common mode	Bulk current	${}^3 \leq 10$	${}^3 \leq 50$	${}^3 \leq 37$
Long pulse wire-to-ground	Wire current	${}^3 \leq 10$	${}^3 \leq 50$	${}^3 \leq 37$
Control/signal/data line LLPMs				
Short pulse common mode	Bulk current	≤ 500	$\leq 2.5 \times 10^{10}$	$\leq 3.1 \times 10^{-1}$
Short pulse wire-to-ground	Wire current	${}^2 \leq 500/\sqrt{N}$ or 50	${}^2 \leq 2.5 \times 10^{10}/\sqrt{N}$ or 2.5×10^9	${}^2 \leq 3.1 \times 10^{-1}/\sqrt{N}$ or 3.1×10^{-2}
Intermediate pulse common mode	Bulk current	No damage or performance degradation ¹		
Intermediate pulse wire-to-ground	Wire current	No damage or performance degradation ¹		
Long pulse common mode	Bulk current	${}^3 \leq 10$	${}^3 \leq 50$	${}^3 \leq 37$
Long pulse wire-to-ground	Wire current	${}^3 \leq 10$	${}^3 \leq 50$	${}^3 \leq 37$

MIL-STD-188-125-2**APPENDIX B**TABLE B-VI. Maximum allowable residual response norms for LLPM testing - Continued.

Notes.

- ¹ Pass/fail criteria on the residual response norms are not specified for the intermediate pulse current injection test sequence. The pass/fail criteria of no POE protective device damage or performance degradation also applies to PCI test sequences where this note does not appear in the table.
- ² N is the number of conductors in the cable. The larger of these two amplitudes is the maximum allowable norm limit.
- ³ The maximum allowable norm limits listed for the long pulse test sequence assume the use of a 1,000-A drive pulse, with risetime ≤ 0.2 s and FWHM ≥ 20 s. When other allowed drive pulses are used, the LLPM is required to attenuate the peak current, peak rate of rise, and root action norms by a factor of at least 100.

MIL-STD-188-125-2

APPENDIX B

B.4.9 Post-test analysis. Post-test analysis of PCI acceptance and verification test data is required to correct for probe and instrumentation system response characteristics and to convert the measured results into norms in engineering units. Additional analysis of PCI verification test data shall be performed to assist in developing a definitive statement of system and subsystem hardness. Detailed requirements for post-test analysis of PCI verification test results will be established by the sponsoring agency for the test. They will generally include calculations of threat responses from CW immersion, threat-level illumination, and PCI test data; analysis of verification test adequacy; development of hardness conclusions; and recommendations for corrective actions, if required.

B.4.10 Data classification. Test data may be classified. DNA-EMP-1 and the security classification guide for the specific system should be consulted for guidance.

B.4.11 Alternate test methods. When approved by the sponsoring agency for the test, cable shield injection may be used for PCI verification testing on shielded intrasite multiconductor (at least seven penetrating core conductors) control/signal/data lines in lieu of the common mode PCI requirement. Maximum required current amplitude and other waveform parameters for cable shield injection shall be as shown in table B-VII. Intrasite cable shields shall be driven over their entire length by removing or buffering/isolating intermediate grounds and other low-impedance ground paths along the cable run. Residual internal transient measurements shall be bulk current measurements on the core conductors of the cable. Maximum allowable residual internal response pass/fail criteria of table B-V apply.

TABLE B-VII. PCI source parameters and waveform for cable shield drives.

Class of Electrical POE/ Type of Injection	Double Exponential Waveform (figure B-1)			
	Peak Short-Circuit Current (A)	Source Impedance (ohms)	Risetime (s)	FWHM (s)
Shielded intrasite control/signal/data line POEs Short pulse shield-to- ground	1,000	≥ 60	≤ 2×10 ⁻⁸	5×10 ⁻⁷ - 5.5×10 ⁻⁷

MIL-STD-188-125-2

APPENDIX B

B.5 DETAILED REQUIREMENTS

B.5.1 PCI test requirements for intrasite power line and control/signal/data line POE protective devices.

B.5.1.1 Test configurations. Typical configurations for short pulse PCI testing of intrasite power line and control/signal/data line POE protective devices are illustrated in figure B-2, and a typical PCI instrumentation and data recording system is shown in figure B-3. The pulse generator output may be directly coupled to the circuit under test, or it may be capacitively or inductively coupled. The injected current sensor shall be on the intrasite cable within 15 cm (6 in) of the external terminal of the POE protective device, and there shall be no branches in the wiring between the sensor location and the external terminal. The residual internal current sensor shall be inside the barrier within 15 cm of the internal terminal of the POE protective device, and there shall be no branches in the wiring between the sensor location and the internal terminal.

If the associated LLPM is available for testing, the intermediate pulse current shall be injected at the long-line terminal of the LLPM. Only the cable to the POE protective device under test shall be connected at the LLPM intrasite terminals. The current shall be injected at the external terminal of the POE protective device under test, at the same location where the short pulse injection occurs, if the LLPM cannot be provided for testing.

Common mode PCI tests are required only for verification testing. Intermediate pulse wire-to-ground tests of control/signal/data line POE protective devices are required for acceptance, but they are not required for verification.

B.5.1.1.1 Acceptance test load configuration. For PCI acceptance testing of a power or control/signal/data line POE protective device, the external load (long-line load for intermediate pulse injection at the long-line terminal of an LLPM) shall be an open circuit. The internal load shall be a dummy resistor of the value specified in table B-IIIa. For the wire-to-ground test, only the internal terminal under test is required to be terminated in the specified resistance. Wiring that connects the load resistor between the internal terminal of the POE protective device and its enclosure shall be ≤ 30 cm (12 in) in length.

B.5.1.1.2 Verification test load configuration. For PCI verification testing of a power or control/signal/data line POE protective device, the external load (long-line load for intermediate pulse injection at the long-line terminal of an LLPM) shall be the actual external equipment or an equivalent dummy load impedance that permits the circuit under test to be energized and

MIL-STD-188-125-2

APPENDIX B

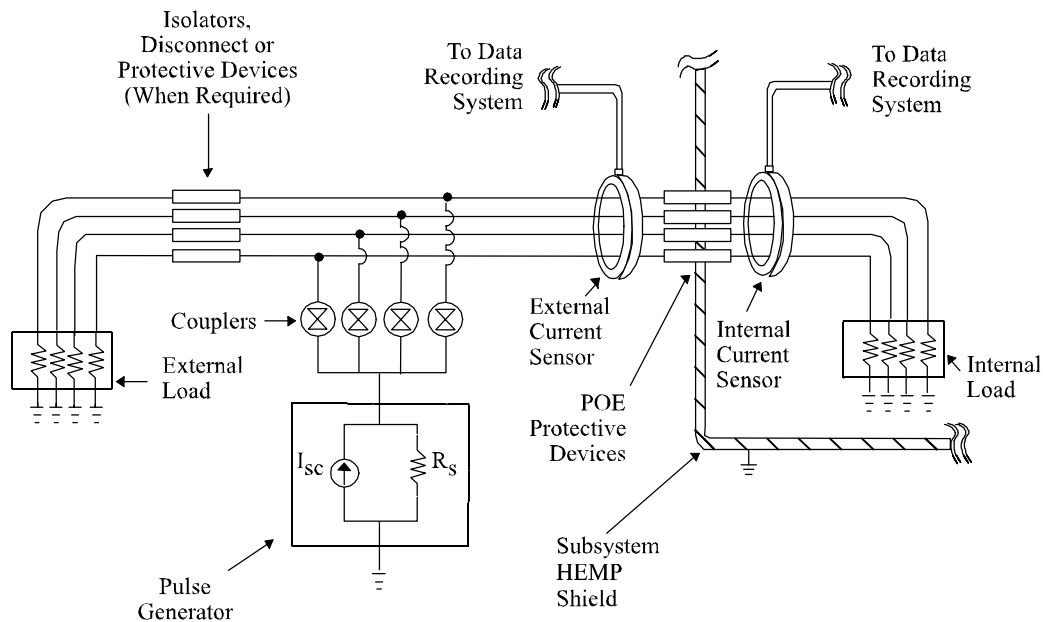

a. Common mode test configuration.

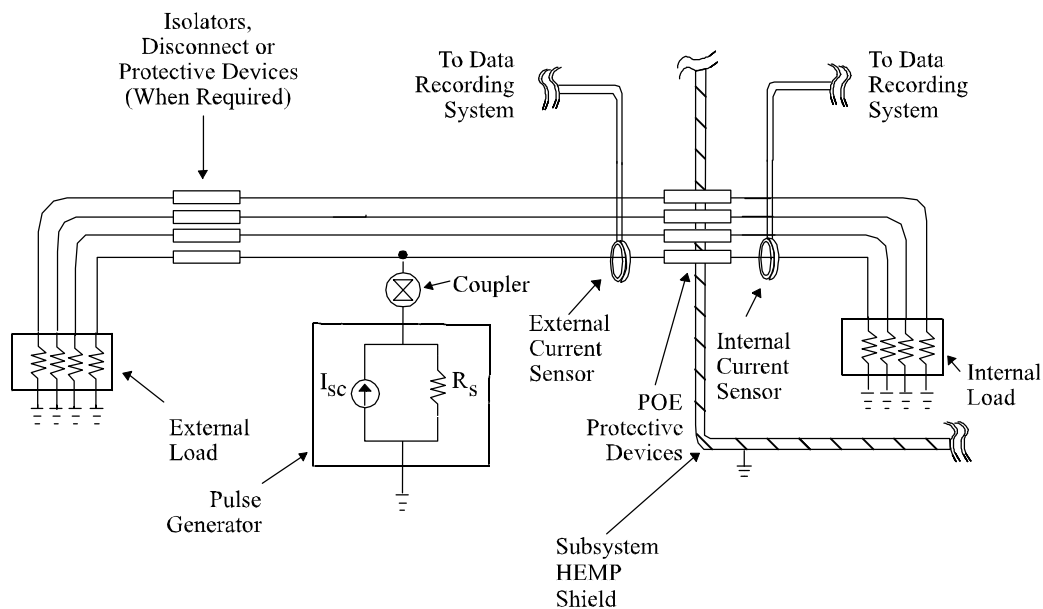

b. Wire-to-ground test configuration.

FIGURE B-2. POE protective device short pulse PCI test configurations.

MIL-STD-188-125-2

APPENDIX B

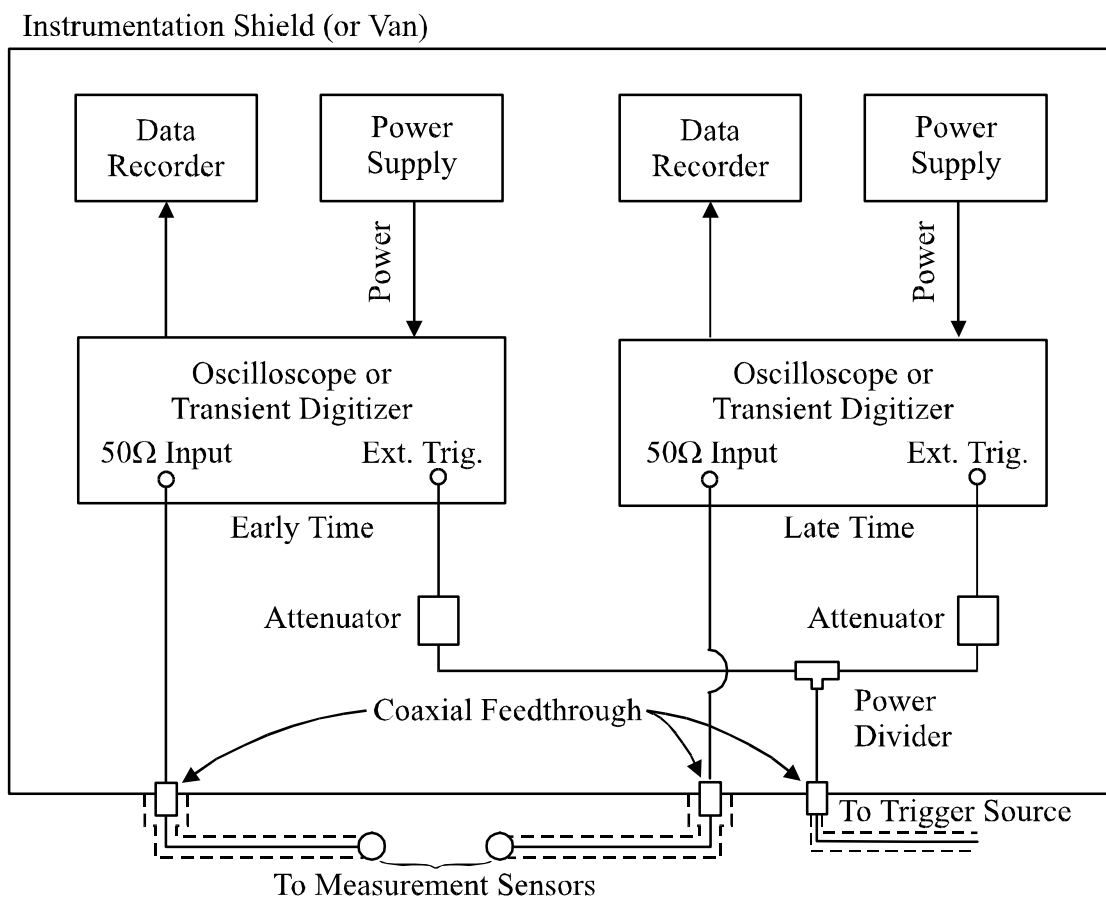

FIGURE B-3. Typical PCI data recording system.

performing actual or simulated mission functions⁹. Isolators, which are compatible with normal operation of the circuit, shall be installed on the intrasite conductors under test to direct the injected current toward the POE protective device (see figure B-2).

The internal load for PCI verification testing shall be the installed system equipment, which shall be energized and performing actual or simulated mission functions¹⁰. The connection

⁹ When the external equipment is not designed to withstand the PCI test transients, temporary protection should be provided or a dummy load should be used in place of the external equipment.

¹⁰ When the circuit under test operates at voltage greater than 600 Vac or 600 Vdc and cannot safely be tested with power on, PCI verification testing may be conducted in a deenergized condition. Switches, relay contacts, and other circuit interrupters shall be placed in the operating state to simulate the power-on configuration.

MIL-STD-188-125-2

APPENDIX B

between the internal terminal of the POE protective device and the load equipment shall be made using the installed system cabling.

B.5.1.2 Pulse generator requirements. Maximum short-circuit current amplitude, waveform, and source impedance requirements of the double-exponential short pulse and intermediate pulse generators required for PCI acceptance and verification testing of intrasite power line and control/signal/data line POE protective devices shall be as shown in table B-IIIa and figure B-1.

B.5.1.3 Test sequence. To minimize the possibility of POE protective device or equipment damage, a series of pulses at increasing amplitudes shall be applied as follows:

a. Pulse at the lowest available output from the pulse generator. This level shall be ≤ 10 percent of the applicable maximum amplitude in table B-IIIa or less than the amplitude that activates any nonlinear components in the POE protective device, whichever is greater.

b. Perform a series of pulses, increasing the amplitude by a factor of approximately two at each step. When testing multiple circuits with identical POE protective devices, this series of intermediate pulses may be abbreviated after the first two samples.

c. Pulse at the maximum required amplitude for the circuit under test. Peak current should not exceed 110 percent of the maximum level listed in table B-IIIa.

This sequence shall be used for both PCI acceptance and PCI verification testing.

CAUTION: Electrical POE protective devices have limited pulse lives. The number of test pulses delivered to each device, peak currents, and pulse widths should be recorded for inclusion in maintenance records. If the total number of previous pulses on a device exceed 90 percent of the rated life, it should be replaced before starting the test.

B.5.2 PCI test requirements for RF antenna line POE protective devices. The HEMP protection for an RF antenna installation and the POE protective device at the antenna line penetration through a subsystem electromagnetic barrier shall be tested in accordance with the general procedure for special protective measures. The test sequence shall include coupling measurements on the antenna installation; PCI testing at the antenna terminals; PCI testing on the antenna line shield; and PCI testing of the protected MCE, when required.

MIL-STD-188-125-2

APPENDIX B

B.5.2.1 Coupling measurements. Coupling measurements shall be made on the complete antenna installation (figure B-4) that includes the antenna; antenna protective device, if provided; antenna-mounted electronics and tuning circuits outside the electromagnetic barrier, if provided; the external RF transmission line; and the electrical POE protective device (or primary and secondary electrical POE protective devices, if the protected interior equipment is within a special protective barrier). The antenna line core conductor shall be terminated inside the electromagnetic barrier into a dummy resistor, with resistance equal to the interior transmission line characteristic impedance, for acceptance testing. The core conductor shall be terminated into the installed system equipment, which shall be energized and performing actual or simulated mission functions, for verification testing. The shield conductor shall be connected to the installed equipment or to the HEMP shield for both test sequences. If the complete antenna installation is not available at the time of system acceptance from the contractor, acceptance testing shall be deferred until the complete installation becomes available.

Excitation for the coupling measurements may be supplied by CW immersion, threat-level illumination, subthreat transient field illumination, or another threat-relatable method. To the extent practical, the locations and polarizations of the transmitting antennas shall be chosen to maximize the antenna response. Measurements of the current coupled to the signal-carrying core conductor shall be made at the antenna terminals and on the protected side of the barrier POE protective device (or primary and secondary special POE protective devices). Coupling measurements on antenna installations with tuning circuits outside the electromagnetic barrier shall be made at the lowest operating frequency, a midband operating frequency, and the highest operating frequency.

Coupling measurements shall be extrapolated to the upper-bound HEMP-induced responses for the MIL-STD-2169 threat environment, assuming linear behavior of the antenna installation and its HEMP protection measures. The extrapolation shall include a factor of 10 to account for uncontrollable coupling parameters, such as incident field departure from planarity and ground conductivity, and other uncertainties present in the coupling test (see MIL-HDBK-423), unless a smaller correction factor can be justified in the analysis. The peak time-domain amplitude of the antenna upper-bound response and dominant response frequency (or frequencies), indicated by a significant peak in the current response spectrum per unit incident field versus frequency curve, shall be determined. The threat-extrapolated peak amplitude of the residual internal response current shall also be determined.

It is not necessary to repeat the coupling measurements during the verification test program if the configuration of the antenna installation and equipment in its vicinity has not changed between acceptance and verification testing. PCI verification injection levels shall be determined from the extrapolated acceptance coupling measurements, when new coupling measurements are not required.

MIL-STD-188-125-2

APPENDIX B

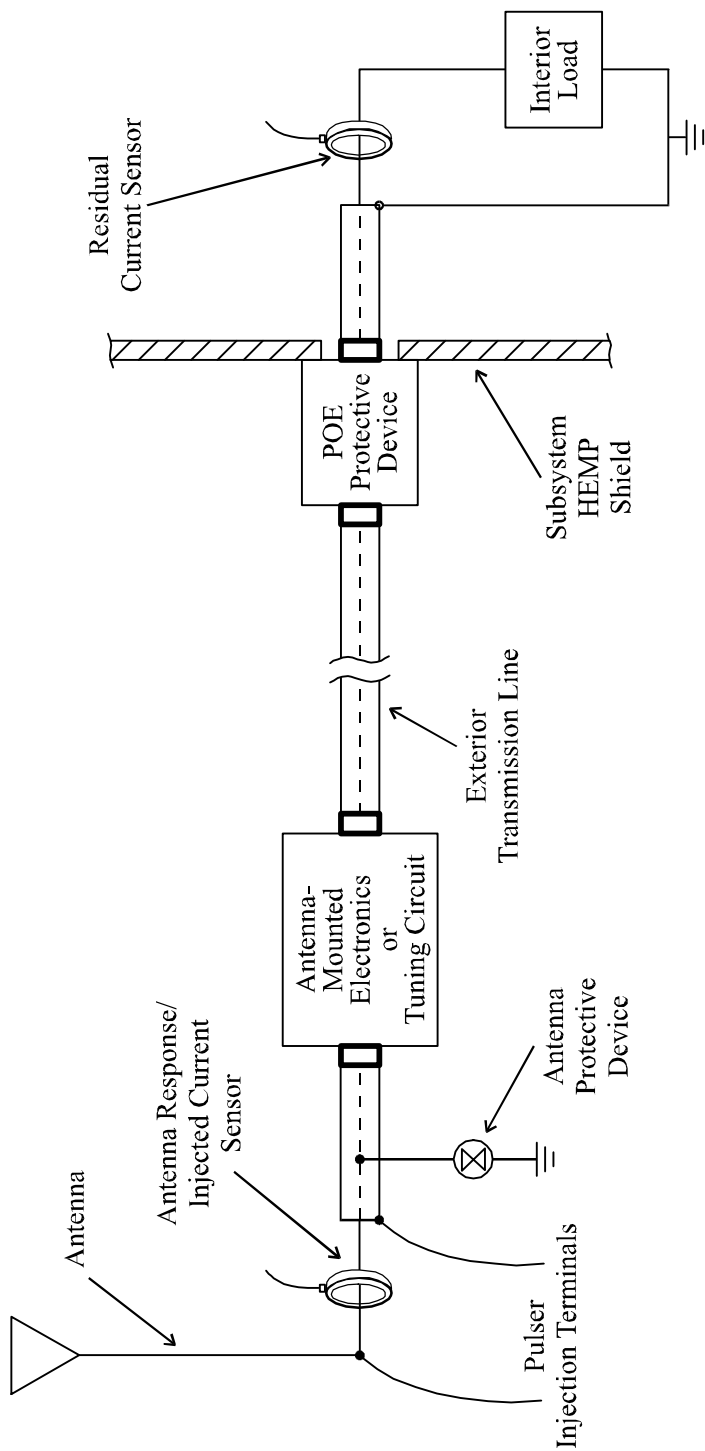

FIGURE B-4. Antenna subsystem configuration for coupling measurements and PCI testing.

MIL-STD-188-125-2

APPENDIX B

B.5.2.2 Antenna terminal PCI test. PCI testing on an RF antenna line core conductor shall be performed on the complete antenna installation, using injections at the antenna terminals. An antenna with tuning circuits outside the electromagnetic barrier shall be PCI tested at the lowest operating frequency, the midband operating frequency at which coupling measurements were acquired, and the highest operating frequency. An antenna subsystem with multiple dominant response frequencies shall be tested at all such frequencies.

Maximum short-circuit current amplitude, waveform, and source impedance requirements of the pulse generators required for PCI acceptance and verification testing of RF antenna installation and antenna line POE protective devices shall be as shown in table B-IIIb. The double-exponential short pulse generator shall be used for testing at dominant response frequencies ≤ 30 MHz. The charge line pulser, with the length of the charge line adjusted to the quarter-wavelength of the applicable frequency, shall be used for testing at dominant response frequencies > 30 MHz. If the required injection level at a dominant response frequency > 30 MHz exceeds the capability of the charge line pulser, the double-exponential short pulse generator shall be employed. The highest required current injection level shall be that supplied at the pulser charge voltage that produces two times the upper-bound antenna terminal response into a short-circuit calibration load.

Injections shall be sequentially performed at approximately 10 percent, 25 percent, 50 percent, and 100 percent of the highest required level. Injected current and residual internal current waveforms shall be recorded, and peak levels shall be graphed versus pulser charge voltage. Additional pulses shall be applied at pulser charge voltages where the responses are nonlinear functions of the voltage. These additional shots ensure that the largest pulser-produced peak residual current, which may not occur at the highest injection level, is recorded.

B.5.2.3 Antenna line shield PCI test. Maximum short-circuit current amplitude, waveform, and source impedance requirements of the double-exponential short pulse generator required for PCI acceptance and verification testing of RF antenna line shields shall be as shown in table B-IIIb. For PCI acceptance testing, the interior load on the core conductor shall be a dummy resistor with resistance equal to the characteristic impedance of the interior transmission line. The shield shall be connected to the installed equipment or the subsystem HEMP shield. For verification testing, the core conductor and shield shall be terminated normally into the installed equipment.

The maximum feasible length of the exterior antenna line shield shall be driven by removing or buffering/isolating intermediate grounds and other low-impedance ground paths along the run. The test sequence shall be the same as that prescribed for testing other electrical POE protective devices (see B.5.1.3).

MIL-STD-188-125-2

APPENDIX B

B.5.2.4 Internal equipment test. If the norms of the residual internal transient current measured in the antenna terminal PCI test exceed the applicable maximum allowable limits (see table B-Vb), a special protective volume shall be established to enclose the wiring and equipment directly connected to the POE protective device. Verification testing of the special protective barrier and the MCE in the special protective volume is then required.

B.5.3 PCI test requirements for LLPMs.

B.5.3.1 Test configurations. LLPM PCI test configurations are similar those previously shown in figure B-2. Again, the pulse generator output may be directly coupled to the circuit under test, or it may be capacitively or inductively coupled. The injected current sensor shall be on the long-line side within 15 cm (6 in) of its connection point at the LLPM, and there shall be no branches in the wiring between the sensor location and the long-line LLPM connection point. The residual current sensor shall be on the intrasite line side within 15 cm of its connection point at the LLPM, and there shall be no branches in the wiring between the sensor location and the intrasite cable LLPM connection point.

B.5.3.1.1 Acceptance test load configuration. For PCI acceptance testing of an LLPM, the load on the long-line side shall be an open circuit and the load on the intrasite cable side shall be a dummy resistor of the value specified in table B-IV. For the wire-to-ground test, only the intrasite cable connection point under test is required to be terminated in the specified resistance. Wiring that connects the load resistor between the intrasite cable connection point and the LLPM ground connection shall have the minimum practical length.

B.5.3.1.2 Verification test load configuration. For PCI verification of an LLPM, the long-line load shall be the equipment to which the line normally connects or an equivalent dummy load impedance that permits the circuit under test to be energized and operational^{9,10}. Isolators, which are compatible with normal operation of the circuit, shall be installed on the long-line wires under test to direct the injected current toward the LLPM. The intrasite line shall be connected to the LLPM and to the system element (or elements) to which it normally interfaces with the system cables that are used during normal system deployments. All mission-critical subsystems and equipment connected to the LLPM under test shall be energized and performing actual or simulated mission functions.

B.5.3.2 Pulse generator requirements. Maximum short-circuit current amplitude, waveform, and source impedance requirements of the short pulse, intermediate pulse, and long pulse generators required for PCI acceptance and verification testing of LLPMs shall be as shown in table B-IV and figure B-1. Common mode PCI tests are required only for verification testing.

MIL-STD-188-125-2

APPENDIX B

B.5.3.3 Test sequence. To minimize the possibility of LLPM or system damage, a series of pulses at increasing amplitudes shall be applied. The first pulse shall be at the lowest available output from the pulse generator. This level shall be ≤ 10 percent of the applicable maximum amplitude in table B-IV or less than the amplitude that activates any nonlinear components in the LLPM, whichever is greater. A series of pulses, increasing the amplitude by a factor of approximately two at each step, shall then be performed. Finally, a pulse at the maximum required amplitude for the LLPM under test shall be injected. Peak current should not exceed 110 percent of the maximum level listed in table B-IV. This sequence shall be used for both PCI acceptance and PCI verification testing.

B.5.4 Measurements and functional observations.

B.5.4.1 Data requirements. At each step in the testing sequence, both for acceptance and verification testing, the injected pulse amplitude and waveform and the residual response amplitude and waveform shall be recorded¹¹. The residual response waveforms for short pulse tests shall be recorded for 5 ms after the start of the PCI drive pulse, with recording instrument sweep speeds that allow resolution of the early-, intermediate-, and late-time responses. The residual response waveforms for intermediate pulse tests shall be recorded for 50 ms after the start of the PCI drive pulse. The residual response waveforms for long pulse tests shall be recorded for approximately 100 seconds after the start of the PCI drive pulse.

B.5.4.2 Verification test functional observations. Operation of the system MCE shall be monitored during and immediately after each PCI verification test pulse for indications of damage or upset. A detailed description of each abnormal occurrence, along with information concerning the test and operational conditions under which the occurrence was observed, shall be included in the test chronology. A determination whether the observed abnormal occurrence is mission-aborting will be made by the operational authority for the system.

B.5.4.3 Measurement procedures. PCI test procedures for acceptance and verification testing shall be as follows:

a. Set up the pulse generator sources and data acquisition system in the desired configuration, and perform calibrations.

¹¹ When a POE protective device under test leads into a special protective volume inside a subsystem electromagnetic barrier, amplitudes and waveforms shall also be recorded on all electrical POEs through the special protective barrier into the protected volume. The measurements shall be made in the protected volume. Pass/fail criteria for these data are the same as the pass/fail criteria for other internal response measurements.

MIL-STD-188-125-2**APPENDIX B**

- b. Deenergize the POE protective device or LLPM circuit to be tested for acceptance testing and when required by safety considerations. Install sensors and pulse generator connections. Reenergize the circuit after sensor installation is complete (verification testing only).
- c. Perform a noise check of the instrumentation and data recording system to ensure that a satisfactory signal-to-noise ratio exists.
- d. Establish the required system, subsystem, equipment state, and test configurations.
- e. Inject a current pulse into the circuit under test, as required by the test sequence (see B.5.1.3, B.5.2.2, B.5.2.3, or B.5.3.3), and record the injected pulse waveform.
- f. Record the response waveforms at the measurement points. Record the results from the functional monitoring of the MCE (verification testing only).
- g. Compare the measured results and functional observations (verification testing only) to the pass/fail criteria (see B.5.5). If the results are not satisfactory, halt the test and investigate the cause of the failure. Take appropriate corrective actions (repair or replace the POE protective device or LLPM, establish a special protective volume, harden the MCE with special protective measures, etc.). Repeat the PCI test procedure after the corrective actions have been completed.
- h. Repeat steps e through g at increasing drive levels until the maximum required transient has been injected. [Additional injections may be required for antenna terminal PCI testing on an RF antenna line at charge voltages where one or more of the measured responses are nonlinear functions of the voltage (see B.5.2.2)].
- i. Establish the next system, subsystem, or equipment state to be tested, and repeat steps d through h (verification testing only).
- j. Deenergize the circuit under test, when required, and remove the sensors and pulse generator connections.
- k. Inspect the POE protective device or LLPM under test. Disconnect the electric surge arrester (ESA), if installed, from the circuit. Measure the voltage at 1 mA dc current of a metal oxide varistor or the dc breakdown voltage of a spark gap. Compare the measured results to the device specifications. If the results are not satisfactory, take appropriate corrective actions. Repeat the PCI test procedure after the corrective actions have been completed.

MIL-STD-188-125-2

APPENDIX B

- l. Reconnect the ESA, if installed, and restore the circuit to its operational configuration.
- m. Proceed to the next POE protective device or LLPM circuit to be tested, and repeat steps b through l.

B.5.5 Pass/fail criteria.

B.5.5.1 Residual response pass/fail criteria. The POE protective device under test shall be considered satisfactory when both of the following criteria are met:

a. Norms of the measured residual responses do not exceed the maximum allowable limits of table B-V for a POE protective device¹² or table B-VI for an LLPM. If residual responses measured in a PCI verification test cannot be discriminated from the circuit operating and noise signal, the test shall be repeated in a power-off condition, and the pass/fail determination for residual response norms shall then be made using the resulting power-off data.

b. Post-test physical inspection of the POE protective device or LLPM; measurements on the ESA, if installed; and response data analysis indicate that the device has not be damaged or unacceptably degraded by the test pulses.

These residual response pass/fail criteria apply for both PCI acceptance and PCI verification testing.

B.5.5.2 Verification test functional pass/fail criteria. Hardening of the MCE within the electromagnetic barrier of the subsystem under test shall be considered satisfactory when both of the following criteria are met:

a. No mission-aborting damage or upsets, as determined by the operational authority for the system, occurred during PCI verification testing of all electrical POE protective devices on penetrating conductors through the electromagnetic barrier of that subsystem.

b. No mission-aborting damage or upsets, as determined by the operational authority for the system, occurred during PCI verification testing of all LLPMs that can interface to that subsystem.

¹² For PCI testing of a primary special electrical POE protective device, on a conductor that penetrates from the subsystem exterior into a special protective volume, the residual response norm pass/fail criteria are as specified for that protective volume. Measurements on conductors that penetrate from the special protective volume into the adjacent protected volume are also required, to demonstrate that the total transient suppression/attenuation through the primary special POE protective device, the connected equipment, and the secondary special POE protective device satisfy the requirements of table B-V.

MIL-STD-188-125-2

APPENDIX B

B.5.6 Test failures. Any failure to satisfy the PCI pass/fail criteria shall be considered a potential HEMP vulnerability. The cause of the potential vulnerability shall be investigated and corrected, if possible. After correction of the deficiency, the applicable portion of the PCI test procedure shall be repeated.

MIL-STD-188-125-2

APPENDIX C

CONTINUOUS WAVE (CW) IMMERSION TEST PROCEDURES FOR TRANSPORTABLE GROUND-BASED SYSTEMS

C.1 GENERAL

C.1.1 Scope. This Appendix is a mandatory part of this standard. The information contained herein is intended for compliance. This Appendix establishes procedures for CW immersion testing of the subsystem electromagnetic barriers required for low-risk high-altitude electromagnetic pulse (HEMP) protection of transportable ground-based systems with critical, time-urgent missions. The procedures are applicable for testing other HEMP-hardened systems, when specified by the procurement documentation.

C.1.2 Applications. These procedures shall be used for CW immersion verification testing of the subsystem shields and aperture point-of-entry (POE) protective treatments after the system is completed and operational.

C.2 REFERENCED DOCUMENTS

C.2.1 Government documents. The following Government documents form a part of this Appendix to the extent specified:

MIL-STD-2169	–	High-Altitude Electromagnetic Pulse (HEMP) Environment (U) (document is classified Secret)
MIL-HDBK-423	–	High-Altitude Electromagnetic Pulse (HEMP) Protection for Fixed and Transportable Ground-Based Facilities, Volume I: Fixed Facilities
DI-NUOR-80928	–	Nuclear Survivability Test Plan
DI-NUOR-80929A	–	Nuclear Survivability Test Report
DNA-EMP-1	–	Electromagnetic Pulse (EMP) Security Classification Guide (U) (document is classified S-RD)

(Copies of documents required by contractors in connection with specific acquisition functions should be obtained from the contracting activity or as directed by the contracting officer.)

MIL-STD-188-125-2

APPENDIX C

C.2.2 Non-Government publications. The following publication forms a part of this Appendix to the extent specified:

IEEE-Std-488.1 – Standard Digital Interface for Programmable Instrumentation

(Applications for copies should be addressed to the Institute for Electrical and Electronics Engineers [IEEE], 445 Hoes Lane, Post Office Box 1331, Piscataway, NJ 08855-1331.)

C.3 DEFINITIONS

C.3.1 Illuminating field (from a CW antenna). The total electromagnetic field, including ground effects, at a point with respect to the transmitting antenna, that would be measured at that point if the system or subsystems under test were not present. Thus, the illuminating field does not include reflections from the system or subsystems under test.

C.3.2 Principal component of the illuminating field (from a CW antenna). A magnetic or electric field component of the illuminating field that is maximized by the antenna geometry and ground effects. For example, azimuthal magnetic field and vertical electric field are principal components of the illuminating field from a vertical monopole antenna over a ground plane.

C.3.3 Reference field measurement (in a CW immersion test). A measured field in a CW immersion test used for monitoring the output from the transmitting antenna and determining the illuminating field. The reference sensor must be placed at a location with respect to the transmitting antenna and system or subsystems under test at which reflections from the test article are negligible at all frequencies of interest, such that the reference measurement has a known relationship to the illuminating field.

To minimize errors in the subsequent data analysis, the reference sensor should measure a field component that is relatively smooth and flat over the entire frequency range. Examples of such components are the horizontal component of the radial magnetic field parallel to and near the ground for a horizontally polarized transmitting antenna and the horizontal component of the azimuthal magnetic field or vertical electric field near ground for a vertically polarized transmitting antenna.

The reference field must be recorded for two types of measurements:

a. Field mapping: Measurement of the illuminating field relative to the reference field in a field mapping area that is free of electromagnetic reflectors, except ground. The location of the

MIL-STD-188-125-2

APPENDIX C

illuminating field sensor with respect to the transmitting antenna and reference sensor must replicate the test article location that will exist during the CW immersion test.

b. System response: Measurements of the residual internal response fields and currents in the system or subsystems under test, relative to the reference field, when the units under test are illuminated during CW immersion.

C.4 GENERAL REQUIREMENTS

C.4.1 General. The CW immersion test is an element of a verification test program, performed as soon as practical after the HEMP-protected system and subsystems are completed. Testing with both vertically and horizontally polarized transmitting antennas is required. For each polarization, the system is exposed in at least two different orientations with respect to the illuminating field polarization and propagation vector directions.

The test can be conducted on the complete system, provided that all of the subsystems can be simultaneously excited with illuminating fields of sufficient strength (see C.5.5.6) to produce an adequate instrumentation measurement range. When the volume illuminated at the required field strength is not large enough to contain the complete system, CW immersion testing can be conducted on one subsystem at a time or on any subset of subsystems.

The test method involves illumination of the exterior surfaces of the electromagnetic barriers of the subsystems under test with radiated CW fields. Field and current responses at measurement points in the subsystem protected volumes are recorded. The responses are analyzed using equations and pass/fail criteria provided in this Appendix to determine the hardness status of the shields and protected aperture POEs. Because coupling to the exposed external cable plant is generally not efficient, CW immersion has limited effectiveness for evaluating conductive POE treatments. Therefore, protection provided for the conductive POEs must also be evaluated with pulsed current injection (PCI) testing (see Appendix B).

C.4.2 Purpose. The purposes of CW immersion verification testing are as follows:

a. To measure attenuation of electromagnetic fields in the HEMP portion of the spectrum by linear elements of the as-built electromagnetic barrier.

b. To identify HEMP shield and aperture POE protective device defects, faulty fabrication or assembly practices, and inadvertent POEs, so that repairs can be made.

MIL-STD-188-125-2

APPENDIX C

c. To characterize the residual internal field and conducted electromagnetic stresses, within limitations of the linearity and planarity assumptions, through post-test analysis.

d. To provide data for HEMP hardness assessment of the transportable system and baseline data for the hardness maintenance/hardness surveillance program.

C.4.3 System/Subsystem HEMP protection test configuration. During conduct of the CW immersion verification test, the system or subsystems under test shall be provided with electrical power and equipment in the protected volumes shall be turned “on.” The HEMP protection shall be intact.

C.4.4 Pretest analysis requirements. Pretest analysis shall be performed to select subsystem locations and exposure orientations with respect to both vertically and horizontally polarized transmitting antennas, reference field sensor locations, and measurement points. Spacing between the subsystems under test and the transmitting antenna shall be chosen, based on the field mapping, to obtain the required illuminating field strength. Exposure orientations shall be chosen to directly illuminate barrier surfaces where the principal points-of-entry are located and to obtain efficient coupling to all of the system elements under test. At least two orientations of each subsystem under test shall be selected, based on the analysis, for each transmitting antenna polarization. The reference field sensor locations shall be chosen to monitor the transmitting antenna output and to minimize reflections from the units under test. Measurement points shall be chosen to provide representative mappings of field responses within the protected volumes of the subsystems under test and current responses within the internal cable plants.

C.4.5 Test equipment requirements. Antennas and other test equipment requirements for CW immersion testing are identified in table C-I.

C.4.6 Operational impact analysis and risk. During CW immersion verification testing, the electromagnetic barrier must remain intact and use of electrically noisy equipment, which is not part of the operational equipment suite, must be restricted in order to achieve the required measurement sensitivity. Construction activity in the area or unusual operations, such as modifications or maintenance, may therefore be affected. Radiated signal levels are low and present no hazards to equipment. Frequency clearance may be required, and it may be necessary to suppress transmissions in specified frequency bands to avoid self-interference or interference with nearby systems or facilities. Normal safety precautions apply. As required, radio frequency radiation protection shall be provided for test personnel.

MIL-STD-188-125-2**APPENDIX C**TABLE C-I. Shielding effectiveness test equipment requirements.

Equipment	Characteristics
Network Analyzers or Equivalent	100 kHz - 1 GHz; minimum sensitivity as required for measurement sensitivity
Power Amplifiers ¹	100 kHz - 1 GHz; power output as required for dynamic range
Antennas ²	100 kHz - 1 GHz
Sensors	100 kHz - 1 GHz; free-field, surface current density, and current
Preamplifiers ³	100 kHz - 1 GHz; amplification and noise figure as required for measurement sensitivity
Data Recorder	Multichannel
Computer and GPIB Control Interfaces ⁴	As required
Fiber Optic Links ⁵	100 kHz - 1 GHz; up to 100 m in length
Instrumentation Shield (or Van) and Power Supplies	As required
Miscellaneous Cables, Attenuators, and Coaxial Switches	As required

¹ Several linear power amplifiers are typically required. A 150-watt (or greater) amplifier may be required in the 100-kHz - 200-MHz frequency range, for example, and a 10-watt amplifier may be adequate at frequencies above 200 MHz.

² Several transmitting antennas may be required to cover the broad frequency range and both polarizations. Examples are vertical monopoles and horizontal dipoles for frequencies up to approximately 100 MHz and various log periodic antennas for frequencies above approximately 100 MHz.

³ Typically, low-noise amplifiers with gains ≥ 30 dB.

⁴ Use of a personal computer with an IEEE-488 general purpose interface bus (GPIB), or equivalent, to control instrumentation and store test data is strongly recommended.

⁵ Radio frequency (RF) and instrumentation control signals may be transmitted through the shield with appropriate fiber optic (F/O) links or high-quality solid metal-shielded coaxial cables. Use of fiber optic links is strongly recommended.

MIL-STD-188-125-2

APPENDIX C

C.4.7 Test plan and procedures. A comprehensive, system-specific test plan and detailed test procedures for CW immersion testing shall be prepared. These may be combined in a single document, or two separate documents may be used. As a minimum, the document shall contain the following information:

- a. A statement of test objectives.
- b. System, subsystem, and long-line protection module (LLPM) identification and descriptions (including drawings of the subsystems showing the locations of all POEs, equipment layout inside the electromagnetic barriers, external cable interconnections; circuit diagrams of LLPMs that interface to the system or subsystems under test; and a description of the HEMP protection measures).
- c. Locations and orientations of the subsystems under test with respect to the transmitting antenna positions and reference sensor locations, and expected measurement sensitivity of the illumination and instrumentation system.
- d. CW illumination and data acquisition equipment descriptions (including manufacturer, model and serial numbers, characteristics, and detailed calibration procedures).
- e. Detailed test procedures (including system, subsystem, and circuit configuration requirements; test configuration diagrams; step-by-step procedures; and measurement point locations).
- f. Any deviations from the requirements of this Appendix.
- g. Data management (including data quality control procedures, data acceptability criteria, annotation and preservation of data records, and pass/fail criteria).
- h. Safety, including electromagnetic radiation and electrical shock hazards.
- i. Security (see C.4.10).
- j. Schedule, including priority of measurements.

Data item description DI-NUOR-80928, "Nuclear Survivability Test Plan," shall be used.

C.4.8 Test report requirements. A CW immersion test report shall be prepared. As a minimum, the test report shall contain the following information:

MIL-STD-188-125-2

APPENDIX C

- a. System identification and a reference to the applicable test plan.
- b. A discussion of any deviations from the test plan or the requirements of this Appendix.
- c. Copies of the measured test results, along with sensor calibrations and instrumentation settings required to convert the data to engineering units. If the data are collected and processed with an automated data acquisition system and a complete data set will be delivered in electronic format, samples of the processed data may be provided in the report.
- d. Summary tables of the measured internal fields and attenuations and threat-extrapolated measured internal currents, with comparisons to the pass/fail criteria.
- e. Test chronology (including sequence of events; findings from investigation into the causes of test failures, if any; and corrective actions and retest results).
- f. Test conclusions, including a definitive statement of the HEMP hardness of the system and subsystem mission functions, based on the results of the complete battery of verification tests and the supporting analysis.

Data item description DI-NUOR-80929A, "Nuclear Survivability Test Report," shall be used.

C.4.9 Post-test analysis. Post-test analysis of CW immersion test data is required to correct for sensor and instrumentation system response characteristics and to convert the measured results into engineering units. Additional analysis of CW immersion test data shall be performed to assist in developing a definitive statement of system and subsystem hardness. Detailed requirements for the post-test analysis will be established by the sponsoring agency for the test. They will generally include calculations of threat responses from PCI, CW immersion, and threat-level illumination test data; analysis of verification test adequacy; development of hardness conclusions; and recommendations for corrective actions, if required.

C.4.10 Data classification. Test data may be classified. DNA-EMP-1 and the security classification guide for the specific system should be consulted for guidance.

C.4.11 Alternate test methods. Other types of illumination, such as wide band noise or repetitive pulsed field radiation, can be substituted for CW illumination, if equivalent frequency coverage and measurement range can be achieved. The test plan and detailed test procedures shall define the illumination approach, source strength, transmitting antenna positions, and predicted shield current density distributions. Adequate data acquisition system sensitivity for verifying the HEMP protection effectiveness and for making pass/fail determinations shall be demonstrated.

MIL-STD-188-125-2

APPENDIX C

When CW immersion of a system is not practical for technical or operational reasons, the test may be performed using CW current injection on the outer surfaces of the subsystem electromagnetic barriers. A system-specific CW shield current injection test plan and detailed test procedures shall define the shield excitation technique, source strength, injection points, and predicted shield current density distributions. Adequate data acquisition system sensitivity for verifying the HEMP protection effectiveness and for making pass/fail determinations shall be demonstrated.

When approved by the sponsoring agency, a program of shielding effectiveness measurements (see Appendix A) and a thorough shielding effectiveness leak detection system (SELDS) survey in accordance with MIL-HDBK-423 guidance may be used for verification testing in lieu of the CW immersion test.

C.5 DETAILED REQUIREMENTS.

C.5.1 Test configuration. A typical CW immersion test configuration for a single element of a HEMP-protected transportable system is illustrated in figure C-1. Two or more subsystems, up to the complete system, can be tested simultaneously, if the illuminating field strength at each of the elements under test and instrumentation system sensitivity are sufficient to provide the needed measurement range. CW immersion testing shall be performed with both vertically polarized and horizontally polarized illuminating fields. At least two orientations shall be tested at each polarization.

During CW immersion testing, the subsystem or subsystems under test shall be provided with electrical power and equipment in the protected volumes shall be turned "on." External cables that connect to the test articles shall be laid out to approximately simulate a deployment configuration. There are no specific requirements for termination of the external cables.

Swept or stepped CW excitation, generated by the network analyzer source, is propagated to the transmitting antenna location via a hardwired or fiber optic link. The signal is amplified and radiated from the antenna (a vertical monopole, horizontal dipole, log periodic antenna, or other appropriate radiator) to illuminate the subsystem. The reference sensor, which is located in a clear area where the measured field has a known relationship to the total field illuminating the subsystem, monitors the transmitting antenna output. Free-field and current sensors monitor the responses at measurement points inside (and outside, if desired) the subsystem electromagnetic barrier. Preamplifiers and fiber optic links are used, as required, in the measurement channels. Reference and measurement point responses are observed on the network analyzer and recorded.

MIL-STD-188-125-2

APPENDIX C

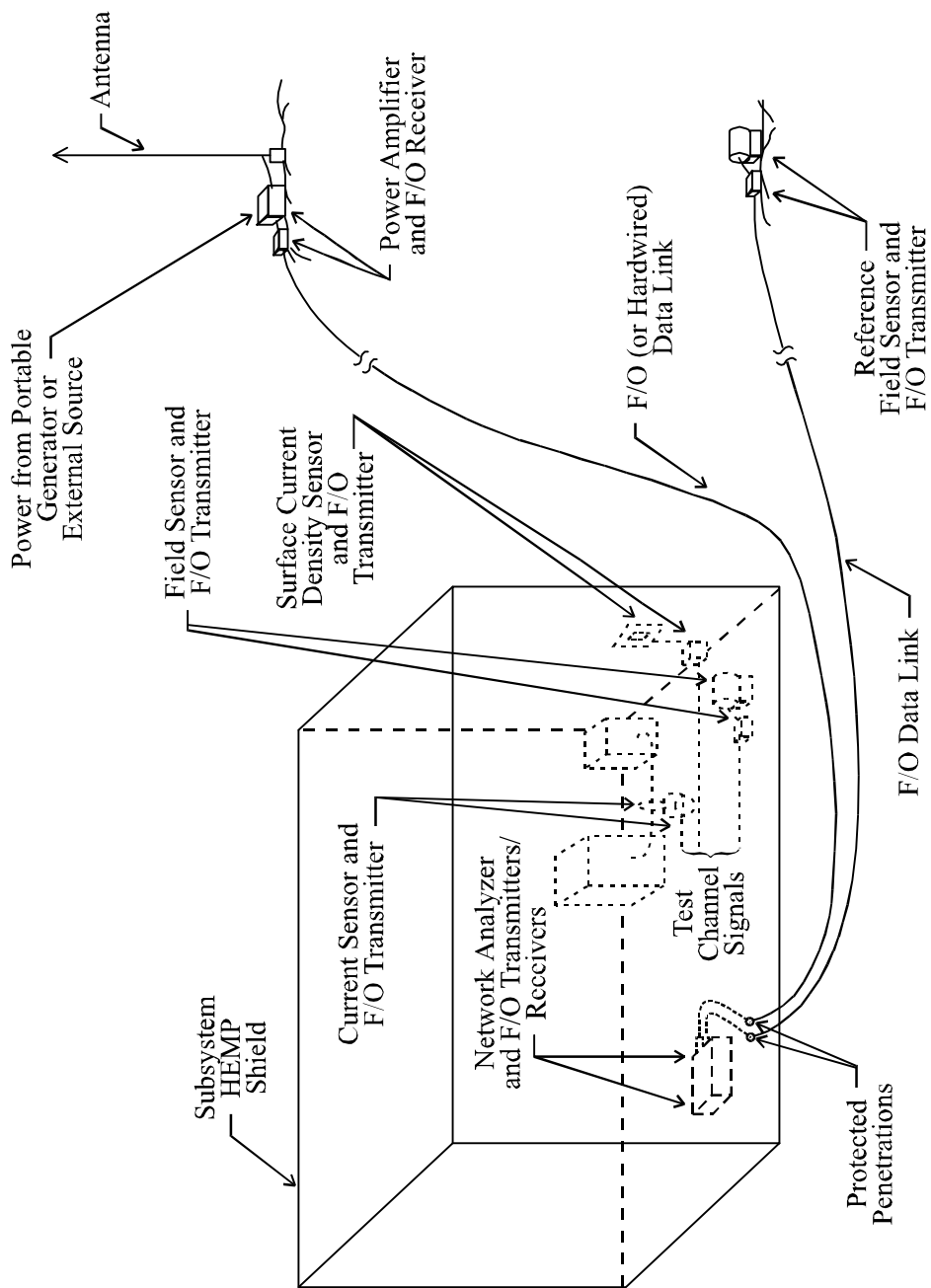

FIGURE C-1. CW immersion testing.

MIL-STD-188-125-2

APPENDIX C

Figure C-2 illustrates a sample 1 MHz - 100 MHz data record, where identical B-dot (time rate of change of the magnetic induction field) sensors are employed in both channels and the reference channel signal is a direct measurement of the principal component of the illuminating field.

C.5.2 Transmitting antenna locations. The transmitting antenna locations shall be chosen to efficiently illuminate the system or subsystems under test with radiated field excitation. The antenna shall be placed as far from the test articles as practical, within physical and measurement sensitivity constraints¹³.

C.5.3 Measurement locations. At least two (\times 3 orthogonal components) electric or magnetic free-field measurement locations and 20 current measurement locations shall be chosen throughout the shielded volume of each subsystem under test for each polarization and orientation. Internal free-field measurement points shall be chosen to provide a representative mapping of residual field responses within the electromagnetic barrier. The free-field measurements shall be made in areas that are relatively clear of equipment. The three orthogonal components of the field response shall be recorded. Internal magnetic free-field measurements should normally be emphasized.

Internal current measurement points shall be chosen to provide a representative mapping of residual current responses in the internal cable plant. Currents shall be measured on selected penetrating cables near their POE protective devices, on selected cables with long interior runs or layouts producing efficient coupling geometries, and on input cables to selected MCE.

Internal measurements of the two orthogonal components of the surface current density in the vicinity of the penetration entry area should also be made, if the interior shield surface in this area has accessibility for installation of the sensor.

C.5.4 Test frequencies. Test data are desired at frequencies from 100 kHz to 1 GHz. It is usually necessary to divide the frequencies into several bands, selecting different antennas to maximize the radiation efficiency in the different bands.

¹³ Results can be interpreted as plane wave responses when $R > \lambda_{\text{MAX}}$ and $R > 2D^2/\lambda_{\text{MIN}}$ - where R is the distance from the antenna to the barrier, λ_{MAX} is the wavelength of the lowest test frequency, λ_{MIN} is the wavelength of the highest test frequency, and D is the antenna characteristic length or the largest barrier dimension transverse to the propagation direction of the illuminating field. For typical CW immersion test geometries, these inequalities are simultaneously satisfied at frequencies from approximately 5 MHz to approximately 400 MHz. When the inequalities are not satisfied, near-field and wave curvature effects may be significant.

MIL-STD-188-125-2

APPENDIX C

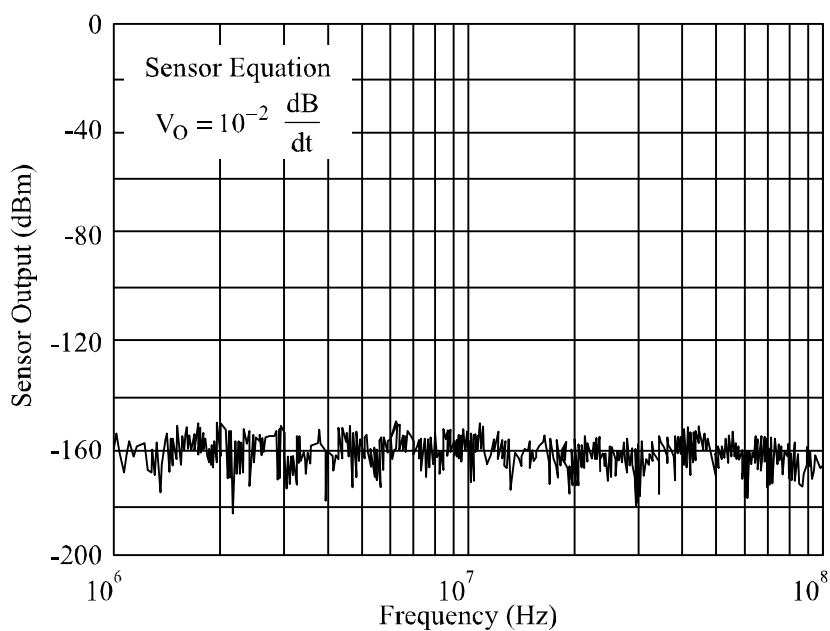

a. Noise/operating signal response.

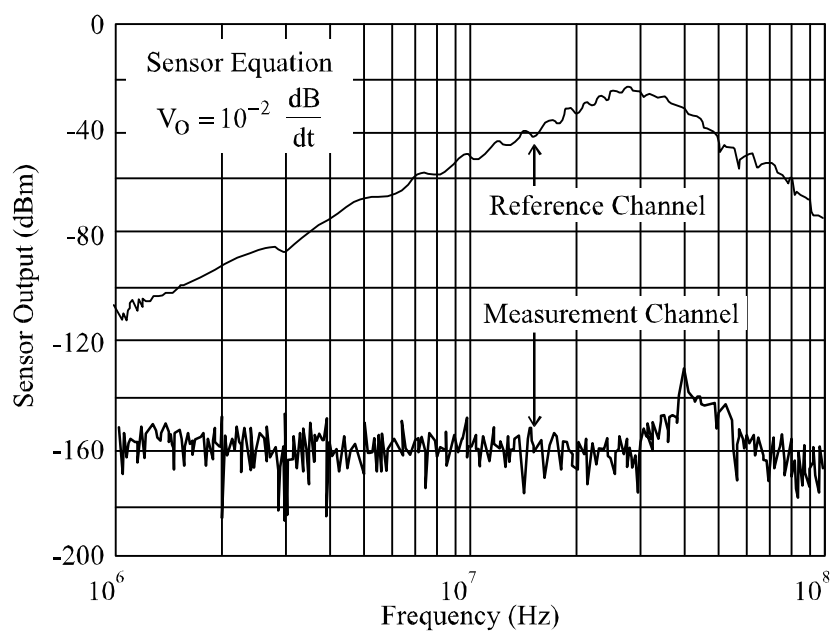

b. Reference and measurement point responses.

FIGURE C-2. CW immersion test record.

MIL-STD-188-125-2

APPENDIX C

C.5.5 Measurement procedures. CW immersion test procedures shall be as follows:

- a. Set up the data acquisition equipment in the desired configuration, and perform calibrations. Minimum sensitivity of the data acquisition system should be - 147 dBm or lower.
- b. Set up the transmitting antenna, choose a reference sensor location, and map the illuminating field. The principal component of the illuminating field¹⁴ should be at least 1 V/m from 1 MHz to 50 MHz and at least 0.1 V/m from 50 MHz to 100 MHz at each subsystem under test. As a design objective, the principal component of the illuminating field should be at least 0.1 V/m from 100 kHz to 1 MHz and at least 0.01 V/m from 100 MHz to 1 GHz at each subsystem under test.
- c. Perform a check of each data acquisition channel to verify link noise immunity. Disconnect the sensor, and terminate the sensor cable in its characteristic impedance. Energize the radiating source, and record the received signal as a function of frequency.
- d. Move the system or subsystems under test into the test area, and configure the units under test in the first orientation. Connect and lay out the external cables. Energize the system or subsystems, and turn the equipment “on.”
- e. Place the measurement sensors, and use preamplifiers as required to obtain the desired measurement sensitivity.
- f. Select appropriate narrow band filter and long sweep settings on the network analyzer. With the source and data acquisition equipment operating normally, except that the power amplifier is turned off, record the noise and operating signal response as a function of frequency. Evaluate the adequacy of the measurement range, and make changes as needed.
- g. Turn the power amplifier on and record the reference and measurement point responses as a function of frequency, using the same filter and sweep time settings as those employed for the noise and operating signal measurements.
- h. Perform data quality control. Annotate and preserve the data records.

¹⁴ The illuminating field strength is expressed as $E_{\text{illuminating}}$ or $c \times B_{\text{illuminating}}$, where $E_{\text{illuminating}}$ is the electric field strength, $B_{\text{illuminating}}$ is the magnetic induction field strength, and c is the speed of light.

MIL-STD-188-125-2**APPENDIX C**

- i. Continue to the next measurement location, and repeat steps e through h.
- j. When the measurements in that orientation are completed, reconfigure the units under test in the next orientation and repeat steps d through i.
- k. When the measurements for one transmitting antenna polarization are completed, continue to the next transmitting antenna polarization and repeat steps b through j.

C.5.6 Pass/fail criteria¹⁵.

C.5.6.1 Residual internal field measurements. In frequency bands where the measurement range is less than the required attenuation, internal CW immersion residual field responses shall be considered satisfactory when there are no measurement point responses observable above the noise and operating signal level.

In the frequency band where the measurement range exceeds the required attenuation (expected to be at least 5 MHz to 1 GHz), internal residual field responses shall be considered satisfactory when the measurement point responses are below the principal component of the illuminating field by at least the required attenuation. This success criterion is expressed by the equations in the following three paragraphs.

C.5.6.1.1 For residual internal magnetic induction field measurements.

$$B_{\text{internal}}(\omega) \leq A(\omega) \times B_{\text{illuminating}}(\omega)$$

where

$$\begin{aligned} f &= \text{frequency (Hz)} \\ \omega &= \text{angular frequency (s}^{-1}\text{)} \\ &= 2 \pi f \end{aligned}$$

$B_{\text{internal}}(\omega)$ = measured component of the magnetic induction field at a measurement point inside the electromagnetic barrier (Wb/m²/Hz)

¹⁵ These pass/fail criteria apply to all measurements made in the protected volume. Responses measured in a special protective volume must not exceed the design values for that special protective volume.

MIL-STD-188-125-2**APPENDIX C**

$A(\omega)$ = minimum attenuation as a function of frequency f

$$= \frac{10^3}{f} \quad 10^5 \text{ Hz} \leq f \leq 10^7 \text{ Hz}$$

$$= 10^{-4} \quad 10^7 \text{ Hz} < f \leq 10^9 \text{ Hz}$$

$B_{\text{illuminating}}(\omega)$ = principal component of the illuminating magnetic induction field at the subsystem under test ($\text{Wb/m}^2/\text{Hz}$)

C.5.6.1.2 For residual internal electric field measurements.

$$E_{\text{internal}}(\omega) \leq A(\omega) \times E_{\text{illuminating}}(\omega)$$

where

$E_{\text{internal}}(\omega)$ = measured component of the electric field at a measurement point inside the electromagnetic barrier (V/m/Hz)

$E_{\text{illuminating}}(\omega)$ = principal component of the illuminating electric field at the subsystem under test (V/m/Hz)

C.5.6.1.3 For internal surface current density measurements.

$$J_{S_{\text{internal}}}(\omega) \leq \frac{A(\omega)}{\mu_0} \times B_{\text{illuminating}}(\omega)$$

where

$J_{S_{\text{internal}}}(\omega)$ = measured surface current density at a measurement point inside the electromagnetic barrier (A/m/Hz)

μ_0 = permeability of free space
 $= 4\pi \times 10^{-7} \text{ H/m}$

MIL-STD-188-125-2

APPENDIX C

C.5.6.2 Residual internal current measurements. CW immersion residual internal current measurements shall be considered satisfactory when the peak amplitude of the threat-extrapolated response, transformed into the time domain, is ≤ 0.1 A and the peak derivative is $\leq 10^7$ A/s. These success criteria are expressed by the following equations:

$$\left| \frac{1}{2p} \int_{2pf_\ell}^{2pf_u} \left[I_{\text{threat}}(\omega) e^{-i\omega t} + I_{\text{threat}}^*(\omega) e^{i\omega t} \right] d\omega \right| \leq 0.1$$

$$\left| \frac{1}{2p} \int_{2pf_\ell}^{2pf_u} \left[I_{\text{threat}}(\omega) e^{-i\omega t} - I_{\text{threat}}^*(\omega) e^{i\omega t} \right] \omega d\omega \right| \leq 10^{-7}$$

for all time t , where

f_ℓ = the lowest CW immersion test frequency (Hz)

f_u = the highest CW immersion test frequency (Hz)

$I_{\text{threat}}(\omega)$ = threat-extrapolated current in the frequency domain (A/Hz)

$$= \frac{I_{\text{internal}}(\omega)}{E_{\text{illuminating}}(\omega)} \times E_{\text{threat}}(\omega)$$

or

$$= \frac{I_{\text{internal}}(\omega)}{B_{\text{illuminating}}(\omega)} \times B_{\text{threat}}(\omega)$$

$I_{\text{threat}}^*(\omega)$ = complex conjugate of $I_{\text{threat}}(\omega)$

$I_{\text{internal}}(\omega)$ = measured current at a test point inside the electromagnetic barrier (A/Hz)

MIL-STD-188-125-2**APPENDIX C**

$E_{\text{threat}}(\omega)$ = early-time HEMP threat electric field in the frequency domain (V/m/Hz)
(see MIL-STD-2169)

$B_{\text{threat}}(\omega)$ = early-time HEMP threat magnetic induction field in the frequency domain
(Wb/m²/Hz) (see MIL-STD-2169)

C.5.7 Test failures. Any failure to satisfy the CW immersion pass/fail criteria shall be considered a potential HEMP vulnerability. The cause of the potential vulnerability shall be investigated and corrected, if possible. After correction of the deficiency, the applicable portion of the CW immersion test procedure shall be repeated.

MIL-STD-188-125-2**APPENDIX D****THREAT-LEVEL ILLUMINATION TEST PROCEDURES
FOR TRANSPORTABLE GROUND-BASED SYSTEMS****D.1 GENERAL**

D.1.1 Scope. This Appendix is a mandatory part of this standard. The information contained herein is intended for compliance. This Appendix establishes procedures for threat-level illumination testing of the low-risk high-altitude electromagnetic pulse (HEMP) protection for transportable ground-based systems with critical, time-urgent missions. The procedures are applicable for testing other HEMP-hardened systems, when specified by the procurement documentation.

D.1.2 Applications. These procedures shall be used for threat-level illumination verification testing of the system HEMP protection measures after the system is completed and operational.

D.2 REFERENCED DOCUMENTS

D.2.1 Government documents. The following Government documents form a part of this Appendix to the extent specified:

MIL-STD-2169	–	High-Altitude Electromagnetic Pulse (HEMP) Environment (U) (document is classified Secret)
DI-NUOR-80928	–	Nuclear Survivability Test Plan
DI-NUOR-80929A	–	Nuclear Survivability Test Report
DNA-EMP-1	–	Electromagnetic Pulse (EMP) Security Classification Guide (U) (document is classified S-RD)

(Copies of documents required by contractors in connection with specific acquisition functions should be obtained from the contracting activity or as directed by the contracting officer.)

D.2.2 Non-Government publications. The following publication forms a part of this Appendix to the extent specified:

IEEE-Std-488.1	–	Standard Digital Interface for Programmable Instrumentation
----------------	---	-------------------------------------------------------------

MIL-STD-188-125-2

APPENDIX D

(Applications for copies should be addressed to the Institute for Electrical and Electronics Engineers [IEEE], 445 Hoes Lane, Post Office Box 1331, Piscataway, NJ 08855-1331.)

D.3 DEFINITIONS

D.3.1 Threat-level illumination. Illumination of a system or subsystems with a simulated HEMP environment that approximates significant features of the threat environment specified in MIL-STD-2169.

D.3.2 Field mapping (of a simulator). Measurement of the magnetic and electric field components of the simulated HEMP environment, relative to the reference field measurement, at regularly spaced positions throughout the region illuminated by the simulator. Field mapping is performed when no test article is present. Since it is generally not possible to eliminate ground reflections from a free-field radiating simulator or reflections from the termination of a bounded wave simulator, the field mapping measures the illuminating field from the simulator.

D.3.3 Incident field (from a simulator). The electromagnetic field radiated by the simulator, not including ground reflections, reflections from the termination of a bounded wave simulator, or reflections from a system or subsystems under test. Since it is generally not possible to measure the incident field from a simulator, it must be computed from measurements of the illuminating field.

D.3.4 Illuminating field (from a simulator). The total electromagnetic field from a HEMP simulator, including ground reflections and reflections from the termination of a bounded wave simulator, that would be measured during field mapping, as a function of location within the illuminated region, when the system or subsystems under test are not present. Thus, the illuminating field does not include reflections from the system or subsystems under test.

D.3.5 Reference field measurement (in a simulator). A measured field in a threat-level illumination test used for monitoring the simulator output and determining the incident and illuminating fields. The reference sensor must be placed at a location at which reflections from the system or subsystems under test are negligible, such that the reference measurement has a known relationship to the illuminating field.

D.3.6 Working volume (of a simulator). The volume within the region illuminated by the simulator where the incident field satisfies threat-level amplitude, uniformity, and other criteria specified in this test procedure (see D.5.1).

MIL-STD-188-125-2

APPENDIX D

D.3.7 System/subsystem response. The effects of simulated HEMP threat-level illumination on a system or subsystem under test, including the induced fields, currents, and voltages at the measurement points and the functional impacts on the operation of the system or subsystem.

D.4 GENERAL REQUIREMENTS.

D.4.1. General. Threat-level illumination testing is conducted as an element of a system hardness verification test program, performed as soon as practical after the HEMP-protected system and subsystems are completed and operational. Testing in both vertically polarized and horizontally polarized HEMP simulators is required. For each polarization, the system is exposed in at least two different orientations with respect to the incident field polarization and propagation vector directions.

The test can be conducted on the complete system, provided that the working volume of the simulator is of sufficient size to simultaneously excite all of the system elements with threat-like fields. When the working volume is not large enough to contain the complete system, threat-level illumination testing can be conducted on any fully functional subsets of subsystems and mission-critical equipment (MCE) outside the subsystem barriers.

The test method involves illumination of the exterior surfaces of the electromagnetic barriers of the subsystems and equipment under test with radiated transient fields that simulate all or part of the HEMP threat environment. In the context of this standard, only the early-time (E1) component of the MIL-STD-2169 threat is simulated. Field and current responses at measurement points in the subsystem protected volumes, coupling to cables of equipment hardened with special protective measures, and functional impacts on the mission operations are recorded. The responses are analyzed using pass/fail criteria provided in this Appendix to determine adequacy of the hardening provided by the shields, protected aperture points-of-entry (POEs), and special protective measures. Because coupling to the exposed external cable plant is generally not efficient, threat-level illumination has limited effectiveness for evaluating conductive POE treatments. Therefore, protection provided for the conductive POEs must also be evaluated with pulsed current injection (PCI) testing (see Appendix B).

D.4.2 Purpose. The purposes of threat-level illumination verification testing are as follows:

- a. To measure attenuation of electromagnetic fields in the simulated HEMP environment by the as-built electromagnetic barrier.
- b. To identify HEMP shield and aperture POE protective device defects, faulty fabrication or assembly practices, and inadvertent POEs, so that repairs can be made.

MIL-STD-188-125-2

APPENDIX D

c. To characterize the residual internal electromagnetic field and conducted transient stresses within the subsystem electromagnetic barriers.

d. To observe operation of the system or subsystems and equipment under test for mission-aborting damage or upsets.

e. To perform coupling measurements on cables of MCE hardened with special protective measures. These coupling measurements are then used to determine pulsed current injection test drive levels for cables that are not directly exposed to the unattenuated HEMP environment.

f. To provide data for HEMP hardness assessment of the transportable system and baseline data for the hardness maintenance/hardness surveillance program.

D.4.3 System/Subsystem HEMP protection test configuration. During conduct of the threat-level illumination verification test, the system or subsystems and equipment under test shall be in a normal operating condition and shall be performing actual or simulated mission functions. The HEMP protection shall be intact.

D.4.4 Pretest analysis requirements. A preliminary assessment of system HEMP survivability/vulnerability shall be made to identify circuits and equipment with the highest likelihood of damage in the simulated environment. These points shall be instrumented during the initial low-level simulator pulses (see D.5.4). Pretest analysis shall also be performed to select locations and orientations within the simulator working volume for placement of the units under test, operating states in which the MCE will be tested, and measurement points. Locations of the subsystems and equipment under test shall be chosen based on the field mapping. Exposure orientations shall be chosen to directly illuminate barrier surfaces where the principal points-of-entry are located and to obtain efficient coupling to all of the system elements under test. At least two orientations of each subsystem and equipment under test shall be selected, based on the analysis, for each simulator field polarization.

An equipment should be tested in multiple states when the transition between states produces significantly different propagation paths for the residual transient, significant changes in the equipment vulnerability threshold, or significant changes in the function being performed. A mission-critical transceiver, for example, should be tested in at least two states, transmitting and receiving, and a digital interface should be tested in both the low and high signal states.

MIL-STD-188-125-2**APPENDIX D**

Measurement points shall be chosen to provide representative mappings of field responses within the protected volumes and special protective volumes and current responses within the cable plants.

D.4.5 Test equipment requirements. Test equipment requirements for threat-level illumination testing are identified in table D-I. A typical threat-level illumination instrumentation system is illustrated in figure D-1.

TABLE D-I. Threat-level illumination test equipment requirements.

Equipment	Characteristics
Early-Time (E1) HEMP Simulator	Simulation fidelity that meets the requirements of this appendix; working volume of sufficient size for the system or the designated subsets of system elements
Sensors	10 kHz - 750 MHz; free-field, surface current density, and current
Preamplifiers ¹	10 kHz - 750 MHz; amplification and noise figure as required for measurement sensitivity
Oscilloscopes or Transient Digitizers	10 kHz - 750 MHz; minimum sensitivity as required for measurement sensitivity
Data Recorder	Multichannel
Computer and GPIB Control Interfaces ²	As required
Fiber Optic Links ³	10 kHz - 750 MHz; up to 100 m in length
Instrumentation Shield (or Van) and Power Supplies	As required
Miscellaneous Cables, Attenuators, and Coaxial Switches	As required

¹ Typically, low-noise amplifiers with gains ≥ 30 dB.

² Use of a personal computer with an IEEE-488 general purpose interface bus (GPIB), or equivalent, to control instrumentation and store test data is strongly recommended.

³ Measured data and instrumentation control signals may be transmitted through the simulator field and subsystem HEMP shields with appropriate fiber optic (F/O) links or high-quality solid metal-shielded coaxial cables. Use of fiber optic links is strongly recommended.

MIL-STD-188-125-2

APPENDIX D

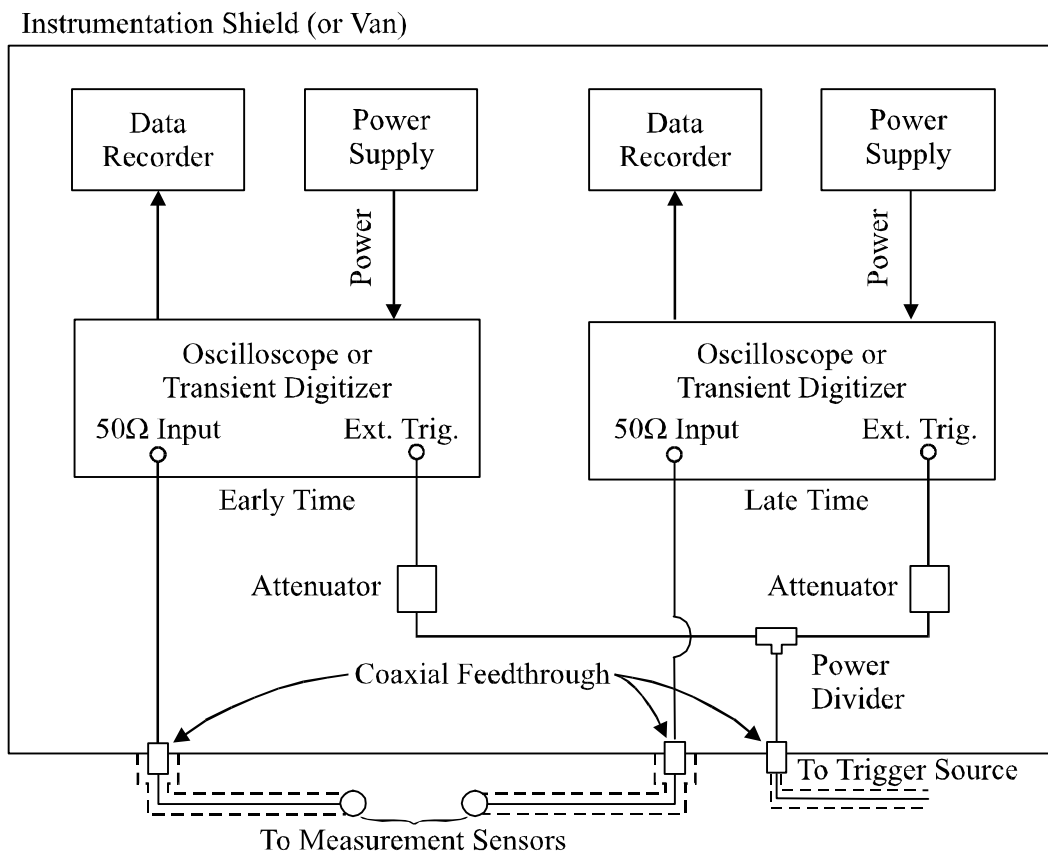

FIGURE D-1. Typical threat-level illumination and data recording system.

D.4.6 Operational impact analysis and risk.

D.4.6.1 Operational impact. During threat-level illumination verification testing, the electromagnetic barrier must remain intact and use of electrically noisy equipment, which is not part of the operational equipment suite, must be restricted in order to achieve the required measurement sensitivity. Construction activity in the area or unusual operations, such as modifications or maintenance, may therefore be affected. Mission operations can continue normally, except as follows:

- a. It may be necessary to deenergize circuits and equipment at various times for installation and removal of sensors.

MIL-STD-188-125-2

APPENDIX D

b. A special sequence of activities may be required, so that the system or subsystems and equipment can be tested in their various operating states (transmitting, receiving, etc.).

D.4.6.2 Risk. Simulator operation involves the use of high voltages and large currents. Relatively high-voltage and high-current responses may also be induced on external cables and into interior circuits. Special high-voltage safety precautions apply. Because of the high voltages and currents, the risk of system or equipment damage cannot be completely eliminated. However, the procedures are designed to minimize this risk.

Radio frequency radiation protection shall be provided for test personnel. A determination shall be made, as part of the hazards analysis, whether operators can be present within the subsystem electromagnetic barriers during simulator pulsing. If operators cannot be present, other provisions for monitoring the system or subsystem functionality shall be developed.

D.4.7 Test plan and procedures. A comprehensive, system-specific test plan and detailed test procedures for system threat-level illumination testing shall be prepared. These may be combined in a single document, or two separate documents may be used. As a minimum, the document shall contain the following information:

- a. A statement of test objectives.
- b. System, subsystem, and LLPM identification and descriptions (including drawings of the subsystems showing the locations of all POEs, equipment layouts inside the subsystem electromagnetic barriers, layout of MCE outside the barriers, diagrams of LLPMs, external cable interconnections, and a description of the HEMP protection measures).
- c. Diagrams of the placement of subsystems and equipment under test in the simulator working volume and placement of other system elements, which are required to achieve functionality, with respect to the simulator working volume. Diagrams of the interconnecting cable layouts. The reference sensor location shall also be indicated.
- d. Simulator and data acquisition equipment descriptions (including manufacturer, model and serial numbers, characteristics, and detailed calibration procedures).
- e. Detailed test procedures (including system, subsystem, and circuit configuration requirements; equipment operating states; test configuration diagrams; functional monitoring provisions; step-by-step procedures; and measurement point locations).
- f. Any deviations from the requirements of this Appendix.

MIL-STD-188-125-2**APPENDIX D**

- g. Data management (including data quality control procedures, data acceptability criteria, annotation and preservation of data records, and pass/fail criteria).
- h. Safety, including electromagnetic radiation and electrical shock hazards.
- i. Security (see D.4.10).
- j. Schedule, including priority of measurements.

Data item description DI-NUOR-80928, "Nuclear Survivability Test Plan," shall be used.

D.4.8 Test report requirements. A threat-level illumination test report shall be prepared. As a minimum, the test report shall contain the following information:

- a. System identification and a reference to the applicable test plan.
- b. A discussion of any deviations from the test plan or the requirements of this Appendix.
- c. Copies of the measured test results, along with sensor calibrations and instrumentation settings required to convert the data to engineering units. If the data are collected and processed with an automated data acquisition system and a complete data set will be delivered in electronic format, samples of the processed data may be provided in the report.
- d. Summary tables of the measured internal fields and attenuations and the measured residual currents, with comparisons to the pass/fail criteria.
- e. Test chronology (including sequence of events; identification of any damage, upsets, or interference observed and the test and operational conditions under which they occurred; findings from investigation into the causes of test failures, if any; and corrective actions and retest results).
- f. Test conclusions, including a definitive statement of the HEMP hardness of the system and subsystem mission functions, based upon the results of the complete battery of verification tests and the supporting analysis.

Data item description DI-NUOR-80929A, "Nuclear Survivability Test Report," shall be used.

D.4.9 Post-test analysis. Post-test analysis of threat-level illumination test data is required to correct for sensor and instrumentation system response characteristics and to convert the measured results into engineering units. Additional analysis of threat-level illumination test data shall be performed to assist in developing a definitive statement of system and subsystem

MIL-STD-188-125-2

APPENDIX D

hardness. Detailed requirements for the post-test analysis will be established by the sponsoring agency for the test. They will generally include calculations of threat responses from PCI, continuous wave (CW) immersion, and threat-level illumination test data; analysis of verification test adequacy; development of hardness conclusions; and recommendations for corrective actions, if required.

D.4.10 Data classification. Test data may be classified. DNA-EMP-1 and the security classification guide for the specific system should be consulted for guidance.

D.5 DETAILED REQUIREMENTS.

D.5.1 Incident field requirements in the simulator working volume. The absolute value of the peak time-domain electric field amplitude of the simulated incident field shall be greater than or equal to the peak time-domain amplitude of the early-time (E1) electric field component of the MIL-STD-2169 HEMP threat environment at all points within the working volume, and it shall vary by no more than a factor of two.

As a design objective, the absolute value of the peak time-derivative of the electric field amplitude of the simulated incident field should be greater than or equal to the peak time-derivative of the MIL-STD-2169 E1 threat environment at all points within the working volume. As a minimum, the absolute value of the peak time-derivative of the simulated incident electric field shall be greater than or equal to 50 percent of the peak time-derivative of the MIL-STD-2169 E1 threat environment at all points within the working volume.

The full-width at half-maximum amplitude (FWHM) of the simulated incident electric field shall be greater than or equal to the FWHM of the E1 electric field component of the MIL-STD-2169 HEMP threat environment at all points within the working volume.

D.5.2 Test configuration. A typical threat-level illumination test configuration for a single element of a HEMP-protected transportable system is illustrated in figure D-2. Two or more subsystems or items of equipment hardened with special protective measures, up to the complete system, can be tested simultaneously, if they can fit within the working volume in an

MIL-STD-188-125-2

APPENDIX D

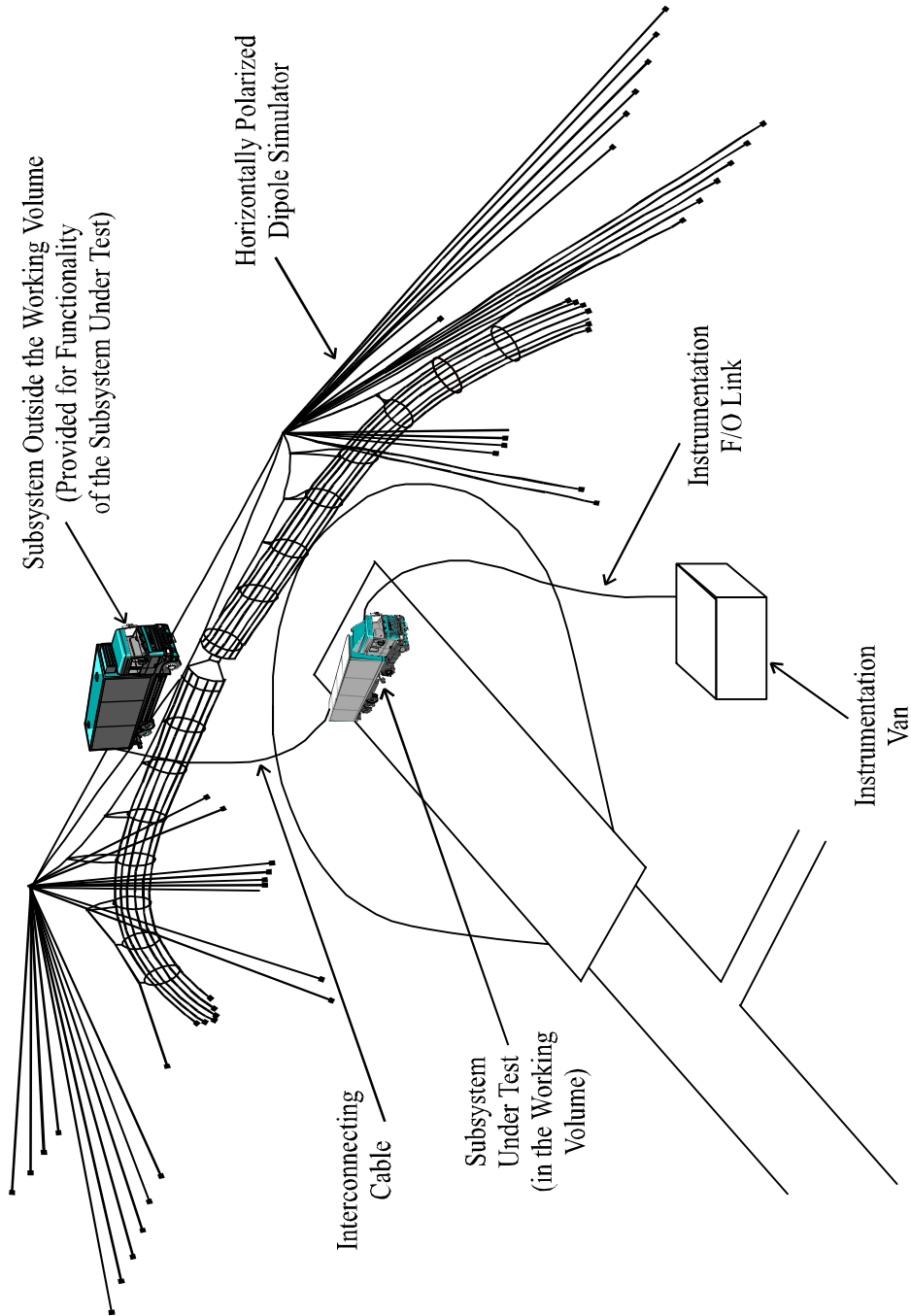

FIGURE D-2. Typical threat-level illumination configuration.

MIL-STD-188-125-2

APPENDIX D

arrangement representative of the deployment configuration. The units under test shall be operating and performing actual or simulated mission functions. Other system elements must be present, although not necessarily within the working volume, as needed to achieve mission functionality of the units under test. Threat-level illumination testing shall be performed in both vertically polarized and horizontally polarized simulators. At least two orientations shall be tested at each polarization.

The simulated HEMP environment is radiated from the simulator antenna to illuminate the subsystem under test. The reference sensor, which is located in an area where the measured field has a known relationship to the illuminating and incident fields, monitors the simulator output. Free-field, surface current density, and current sensors monitor the responses at measurement points inside (and outside, if desired) the subsystem electromagnetic barrier. Preamplifiers and fiber optic links are used, as required, in the measurement channels. Reference and measurement point responses and functional impacts on the operation of the MCE are observed and recorded.

D.5.3 Measurement locations. At least two (\times 3 orthogonal components) electric or magnetic free-field measurement locations and at least 20 current measurement locations shall be chosen inside the shielded volume of each subsystem under test for each polarization and orientation. Internal free-field measurements shall be chosen to provide a representative mapping of residual field responses within the electromagnetic barrier. The free-field measurements shall be made in areas that are relatively free of equipment. The three orthogonal components of the field response shall be recorded.

Current measurements within a subsystem electromagnetic barrier shall be chosen to provide a representative mapping of residual current responses in the internal cable plant. Currents shall be measured on selected penetrating cables near their POE protective devices, on selected cables with long interior runs or layouts producing efficient coupling geometries, and on input cables to selected MCE.

Measurements of the two orthogonal components of the surface current density in the vicinity of the penetration entry area should also be made within the subsystem barrier, if the interior shield surface in this area has accessibility for installation of the sensor.

Current measurements on MCE hardened with special protective measures shall be made on a sufficient number of power and control/signal/data cables and wires, which are not directly exposed to the unattenuated HEMP environment, to characterize the conducted electromagnetic stresses at the equipment level.

MIL-STD-188-125-2

APPENDIX D

D.5.4 Test Sequence. To minimize the possibility of system damage from the high-level transient electromagnetic fields of the HEMP simulator, the following low-level exposure sequence shall be followed when the transportable system or any subset of the system is first placed in the simulator working volume:

- a. After the system or subsystems and equipment are set up and operating, instrument circuits and equipment identified in the pretest analysis as having the highest likelihood of damage in the simulated HEMP environment.
- b. Pulse at the lowest available output from the HEMP simulator, and check the system for damage or functional indications of probable damage with an increase in the output level. If it is judged to be safe to proceed, continue pulsing at the same low-level output until responses have been measured in all of the identified locations.
- c. Linearly extrapolate the low-level responses to threat-level. Select the measurement points to be monitored as the simulator output level is increased, based upon an estimate of the ratio between the threat-extrapolated responses and the vulnerability thresholds of the associated equipment.
- d. Perform a series of pulses, increasing the simulator output level by no more than 50 percent at each step. Based upon the selected measurements, a judgment shall be made whether it is safe to proceed to the next level. Continue this process until threat-level has been reached.

D.5.5 Measurement procedures. Threat-level illumination test procedures shall be as follows:

- a. Set up the data acquisition equipment in the desired configuration, and perform instrument calibrations. Minimum sensitivity of the data acquisition system should be adequate for measuring transient fields of the order of 0.1 V/m and transient currents of the order of 1.0 mA or lower.
- b. Set up the simulator. Perform a check of each data acquisition channel to verify link noise immunity. Disconnect the sensor, and terminate the sensor cable in its characteristic impedance. Pulse the simulator at threat-level, and record the received signal. Eliminate the causes of excessive noise responses.

MIL-STD-188-125-2**APPENDIX D**

c. Map the simulator illuminating fields¹⁶. Determine the peak amplitude, peak derivative, and FWHM of the incident field pulse, and verify that they satisfy minimum working volume requirements (see D.5.1) at locations where the system elements under test will be placed.

d. Move the system, subsystems, or equipment under test into the simulator working volume and set up in the first orientation. Set up the supporting system elements as required for mission functionality of the test articles. Connect and energize the units, and begin performing actual or simulated mission functions.

e. Place measurement sensors for monitoring circuits and equipment identified in the pretest analysis as having the highest likelihood of damage in the simulated HEMP environment. Use preamplifiers as required to obtain the desired measurement sensitivity.

f. Perform the low-level exposure sequence (see D.5.4), to minimize the possibility that the system, subsystems, or equipment will be damaged by threat-level simulator pulses.

g. Place sensors at the measurement points. Establish the required system/subsystem, equipment state, and test configurations.

h. Pulse the simulator at threat level, and record the reference and measurement point responses. Perform data quality control, and annotate and preserve the data records. Record any damage or upsets of the MCE, along with the test and operational conditions that existed at the time the abnormal occurrence was observed, for inclusion in the test chronology.

i. Compare the measured results and functional observations to the pass/fail criteria (see D.5.6). If the results are not satisfactory, halt the test and investigate the cause of the failure. Additional simulator shots at any output level may be made as part of this investigation. Take appropriate corrective actions. Repeat steps g and h after the corrective actions have been completed.

j. When all required measurements in that state have been taken, continue to the next state to be tested and repeat steps g through i.

k. When the measurements in that orientation are completed, reconfigure the units under test in the next orientation and repeat steps e through j. When approved by the sponsoring agency for the test, the low-level exposure sequence can be abbreviated after the first orientation.

¹⁶ The illuminating field strength is expressed as $E_{\text{illuminating}} \text{ or } c \times B_{\text{illuminating}}$, where $E_{\text{illuminating}}$ is the electric field strength, $B_{\text{illuminating}}$ is the magnetic induction field strength, and c is the speed of light.

MIL-STD-188-125-2

APPENDIX D

l. When the subset of subsystems and equipment has been tested in all required states and orientations, remove the units under test from the simulator working volume. Move the next subset into the working volume and repeat steps d through j.

m. Proceed to the second, oppositely polarized simulator. Repeat steps a through l of these measurement procedures.

D.5.6 Pass/fail criteria.

D.5.6.1 Residual internal magnetic induction field measurements¹⁷. Measurements of the residual internal magnetic induction field shall be considered satisfactory when the peak absolute value of the amplitude of the response at each magnetic field measurement point within the protected volume of a hardened subsystem under test is below the peak amplitude of the MIL-STD-2169 E1 magnetic induction field by at least 80 dB.

D.5.6.2 Residual internal electric field measurements¹⁷. Measurements of the residual internal electric field shall be considered satisfactory when the peak absolute value of the amplitude of the response at each electric field measurement point within the protected volume of a hardened subsystem under test is below the peak amplitude of the MIL-STD-2169 E1 electric field by at least 80 dB.

D.5.6.3 Residual internal current measurements¹⁷. Measurements of the residual internal transient current shall be considered satisfactory when the peak absolute value of the amplitude of the response at each current measurement point within the protected volume of a hardened subsystem under test is ≤ 0.1 A and the peak absolute value of its derivative is $\leq 1 \times 10^7$ A/s.

D.5.6.4 Functional pass/fail criteria. Hardening of the MCE within the protected volume of a hardened subsystem under test shall be considered satisfactory when no mission-aborting damage or upsets, as determined by the operational authority for the system, occur during threat-level illumination verification testing.

HEMP protection of MCE hardened with special protective measures shall be considered satisfactory when no mission-aborting damage or upsets, as determined by the operational authority for the system, occur during threat-level illumination verification testing and no mission-aborting damage or upsets occur during the associated PCI testing required by this standard.

¹⁷ These pass/fail criteria apply to all measurements made in the protected volume. Responses measured in a special protective volume must not exceed the design values for that special protective volume.

MIL-STD-188-125-2

APPENDIX D

D.5.7 Test failures. Any failure to satisfy the threat-level illumination pass/fail criteria shall be considered a potential HEMP vulnerability. The cause of the potential vulnerability shall be investigated and corrected, if possible. After correction of the deficiency, the applicable portion of the threat-level illumination test procedure shall be repeated.

MIL-STD-188-125-2

Custodians:

Army - CR
Navy - EC
Air Force - 90
DISA - DC1
NSA - NS

Preparing Activity:

DSWA - DS

(Project TCSS-0037-001)

Review Activities:

OASD - SE
Army - AC, PT
Navy - CG, MC, NC, OM, TD
Air Force - 02, 13, 17, 19, 21, 29, 33, 93
DIA - DI
DISA - DC4
DLA - DH
DMA - MP
JSC - JS
USSPACECOM - US

Civil Agencies Coordinating Activities:

TRANSPORTATION - OST

STANDARDIZATION DOCUMENT IMPROVEMENT PROPOSAL

INSTRUCTIONS

1. The preparing activity must complete blocks 1, 2, 3, and 8. In block 1, both the document number and revision letter should be given.
2. The submitter of this form must complete blocks 4, 5, 6, and 7.
3. The preparing activity must provide a reply within 30 days from receipt of the form.

NOTE: This form may not be used to request copies of documents, nor to request waivers, or clarification of requirements on current contracts. Comments submitted on this form do not constitute or imply authorization to waive any portion of the referenced document(s) or to amend contractual requirements.

I RECOMMEND A CHANGE:

 1. DOCUMENT NUMBER
MIL-STD-188-125-2

 2. DOCUMENT DATE (YYMMDD)
990303

 3. DOCUMENT TITLE High-Altitude Electromagnetic Pulse (HEMP) Protection for Ground-Based C⁴ Facilities
Performing Critical, Time-Urgent Missions; Part 2: Transportable Systems

 4. NATURE OF CHANGE (*Identify paragraph number and include proposed rewrite, if possible. Attach extra sheets as needed.*)

5. REASON FOR RECOMMENDATION

6. SUBMITTER

 a. NAME (*Last, First, Middle Initial*)

b. ORGANIZATION

 c. ADDRESS (*Include Zip Code*)

 b. TELEPHONE (*Include Area Code*)

 7. DATE SUBMITTED
(YYMMDD)

 (1) Commercial
(2) AUTOVON
(*If applicable*)

8. PREPARING ACTIVITY

 a. NAME
Defense Threat Reduction Agency

 b. TELEPHONE (*Include Area Code*)
(1) Commercial
(703) 325-7016

 (2) AUTOVON
221-7016

 c. ADDRESS (*Include Zip Code*)
Attention: Mr. M. Rooney, DTRA/TEL-NSSE
6801 Telegraph Road
Alexandria, VA 22310-3398

 IF YOU DO NOT RECEIVE A REPLY WITHIN 45 DAYS, CONTACT:
Defense Quality and Standardization Office
5203 Leesburg Pike, Suite 1403, Falls Church VA 22041-3466
Telephone (703) 756-2340 AUTOVON 289-2340