

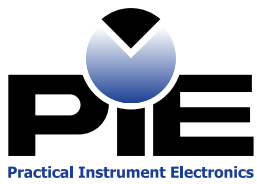

Advanced Test Equipment Corp.

www.atecorp.com

800-404-ATEC (2832)



**PIE 830PM**  
Panel Mounted  
Multifunction Process Calibrator  
mA • V • pH • TC • Ω • RTD • Freq • Pressure  
Operating Instructions



## Contents

### Basic Operation

Switches & Knobs .....	2
Connections.....	2
MAIN Menus - Functions, Units & Ranges.....	3
FEATURE Menu - Stepping & Ramping / Auto Off / Backlight.....	4
Storing EZ-CHECK Outputs & Automatic Stepping .....	5

### Functions and Hookup Diagrams

2-Wire Transmitter Calibration	
Simulate sensor while powering 2-Wire Transmitters .....	6, 7
Universal Isolated Transmitter	
Use the 830 to replace a 2-Wire Transmitter .....	8-11
Milliamp	
Simulate 2 Wire Transmitters .....	12, 13
Source mA, Read mA.....	14, 15
Power/Measure Transmitters .....	16
Using Ground Leak Detection .....	17, 18
Voltage & Millivolt	
Source V & mV; Read V & mV .....	19, 20
pH	
Source pH .....	21
Thermocouple	
Source T/C & Read T/C Sensors .....	22, 23
Resistance	
Source Resistance, Read Resistance & Continuity .....	24, 25
RTD	
Source RTD & Read RTD Sensors .....	26, 27
Frequency	
Source KHz, Hz & CPM; Read KHz, Hz & CPM.....	28, 29
Pressure	
Read Pressure.....	30
Pressure Module Ranges & Specifications .....	31
Pressure Module .....	32

### Warranty

Accessories, Warranty & Additional Information .....	33
--	----

### Specifications

General .....	34-36
Thermocouple Ranges & Accuracies .....	37, 38
RTD Ranges & Accuracies.....	39

### Installation

Panel Cutout Dimensions.....	40
Mounted in Panel .....	41, 42

# Get more tools in a smaller calibrator

Combines eight single function calibrators

*plus* a milliamp calibrator with loop supply

*plus* a loop troubleshooter into a compact panel mounted enclosure!

*Milliamp • Voltage • Frequency • pH • Ohms • Thermocouples • RTDs • Pressure  
Loop Diagnostics • Transmitter Supply*

**1 Detect 'hidden' loop problems** Quickly diagnose troublesome ground faults & current leakage with patented Loop Diagnostic technology. These problems are undetectable with other instruments!

**2 Check all loop parameters at once with LoopScope™** Simultaneously displays current, voltage and resistance to let you know the condition of a live loop. Finds problems with power supplies & loops with too many loads. Patented by PIE!

**3 Automatically detect 2, 3, or 4 wire RTDs** Trouble shoot sensor connections and find broken wires with patented technology. LCD indicates which of the four wires are connected to an RTD sensor.

**4 Swap out faulty transmitters to diagnose control issues** Easily setup the 830 as a universal isolated transmitter for Thermocouple, RTD, frequency, millivolt, resistance or pressure. If the loop is back under control you know the transmitter was faulty. Turn on the LoopScope to simultaneously see the loop current, loop voltage and loop loads for troubleshooting.

**5 Troubleshoot wiring problems without a multimeter** Built in continuity checker with 'beeper' quickly finds broken wires or shorts in instrumentation wiring. Also handy for checking operation of relays and controller outputs.

The PIE Model 830PM is more than a multifunction calibrator. It is also a loop detective that is able to diagnose common problems that other test equipment just can't find. Have a flooded junction box or unknown ground faults? Our Loop Diagnostic technology will detect it. Or use the *LoopScope* to see at a glance all the parameters - milliamps, voltage and resistance - in the loop.

Stop throwing away perfectly good transmitters only to find the problem is somewhere else in the loop. Setup the PIE Model 830PM as an isolated universal transmitter and turn on the Loop Diagnostics. The display will tell you EXACTLY the sensor input, the current output and if there is any uncontrolled current in the loop due to a ground fault, corrosion bridge or moisture. If the control system sees no problem when the 830PM is acting as a transmitter THEN you can replace the faulty transmitter. With RTDs the 830PM automatically detects which of the 2, 3 or 4 wires are connected and unbroken quickly alerting you to a sensor problem. Diagnostic features are covered by US Patent #7,248,058.

Become a troubleshooting technician with Patented Diagnostic Technology - *Available only with PIE Calibrators!*

Practical Instrument Electronics

Tel: 585.872.9350 • Fax: 585.872.2638 • sales@piecal.com • www.piecal.com

## Basic Operation

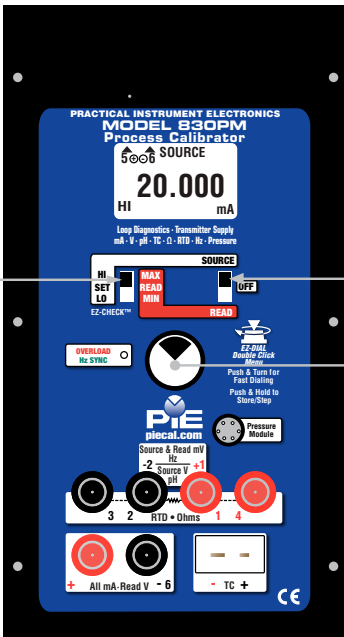

### ② SOURCE/OFF/READ Switch

Select “SOURCE” to output mA, V, pH, T/C,  $\Omega$ , RTD or Hz.

Select “READ” to read mA, V, T/C,  $\Omega$ , RTD, Hz or pressure.

### ③ EZ-DIAL™ KNOB

**SOURCE:** Turn the knob to adjust the output level. Turn clockwise to increase the output, counter clockwise to decrease the output in one least significant digit step at a time. Push down and turn the EZ-DIAL knob for faster dialing.

Press and hold the knob for two seconds to store desired EZ-Check™ HI/LO points in SOURCE mode. Continue to press and hold the knob for two more seconds to start the automatic ramping.

**READ:** Press and hold to transfer the current temperature into the EZ-Check™ MIN/MAX points. This clears the MIN/MAX readings which will update as the input value changes.

Double Click the EZ-DIAL knob to change the function of the calibrator and to select ranges, units and other user settings.

### ① EZ-CHECK™ SWITCH

**SOURCE:** Instantly output two preset settings by moving the EZ-CHECK™ switch to the “LO” position or “HI” position. For fast three point checks select the “SET” position. The 830PM will remember the last “SET” value, even with the power off. These values can easily be changed to suit the calibration requirements. The values stored in the HI and LO positions are also used for Auto Stepping.

**READ:** Slide the switch to the SET position. The 830PM will display the current input value. Slide the switch to HI and the highest value measured since turn-on or reset will be displayed; slide the switch to LO and the lowest value measured since turn-on or reset will be displayed.

## Connections

Test leads with shielded or non shielded banana plugs may be plugged into the protected banana jacks labeled 1 through 6.

PIE external pressure modules may be plugged into the jack marked Pressure Module

Simulating or reading thermocouples requires the use of thermocouple or extension grade thermocouple wire terminated with a miniature thermocouple plug.

Practical Instrument Electronics

Tel: 585.872.9350 • Fax: 585.872.2638 • sales@piecal.com • www.piecal.com

## Configuration

### Double Click Menus - Main Page

Move ② POWER SWITCH to "SOURCE" or "READ".

**DOUBLE CLICK  
EZ-DIAL KNOB  
FOR CONFIGURATION**

V#.#

Turn the ③ DIAL KNOB to move through the two pages of menus. Shown are the MAIN menus for each function. Turn the ③ knob to scroll thru the menus and press the ③ knob to select. Available choices are shown in grey.

### Source mA & Simulate 2 Wire Transmitters

#### MAIN

> EXIT  
 FUNCTION            mA  
 MODE                SOURCE 2W SIM  
 UNITS                mA %  
 HART 250Ω          ON OFF

### Read mA, Power/Measure Transmitters & Leak Detect

> EXIT  
 FUNCTION            mA  
 MODE                READ PWR MEAS  
 UNITS                mA %  
 HART 250Ω          ON OFF

#### Source V

> EXIT  
 FUNCTION            V  
 RANGE                10V 100mV 1V

#### Read V & mV

> EXIT  
 FUNCTION            V  
 RANGE                10V 1V 60V 100mV

#### Source pH

> EXIT  
 FUNCTION            pH

### Source & Read Frequency

> EXIT  
 FUNCTION FREQ  
 RANGE    20KHZ 10000HZ 1000HZ 2000CPM

### Double Click Menus - Main Page

### Source & Read Thermocouples

#### MAIN

> EXIT  
 FUNCTION T/C  
 UNITS       °C °F  
 T/C TYPE    J K E T R S B N L U G C D P  
 COLD JUNC ON OFF

#### Source RTD

>EXIT  
 FUNCTION RTD  
 UNITS       °C °F  
 RTD Pt 100 α=3850 [\*RTD Types - See Read RTD]

#### Read RTD

>EXIT  
 FUNCTION RTD  
 UNITS       °C °F  
 RTD Pt 100 α=3850, α=3902, α=3916, α=3926  
                  Pt 1000 α=3850;  
                  Cu 10 α=4274, Cu 50 α=4280  
                  Ni 120 α=6720, Ni 110 α=5801

#### Source Ohms

> EXIT  
 FUNCTION            OHMS  
 RANGE                400Ω 4000Ω

#### Read Ohms

> EXIT  
 FUNCTION            OHMS  
 RANGE                400Ω 4000Ω CONT

#### Read Pressure

> EXIT  
 FUNCTION PRESSURE  
 UNITS       psi inH2O\* ftH2O\* mmH2O\*  
 cmH2O\* mH2O\* inHg mHg cmHg mmHg  
 torr kg/cm2 kg/m2 hPa kPa MPa bar mbar  
 atm oz/in2 lb/ft2  
 \*Engineering unit available at 4°C, 20°C and 60°F.

## Operating Instructions

### Double Click Menu - STEPPING, AUTO OFF & BACKLIGHT

#### To change the Automatic Stepping settings

Double click the ③ DIAL KNOB at any time the unit is on and the following typical display (will be different for each FUNCTION) will appear for 15 seconds:

MAIN	
> EXIT (1/2)	
FUNCTION	mA
MODE	SOURCE
UNITS	mA
HART 250Ω	ON

Turn the ③ DIAL KNOB to move to the second menu (FEATURES) page.

Turn the ③ DIAL KNOB to move through the menu. Press the ③ DIAL KNOB to toggle between OFF and ON or to change the STEPS/RAMP and the STEP/RAMP TIME settings. These settings are remembered even with the power off.

FEATURES	
> EXIT (2/2)	
AUTO OFF	ON
BACKLIGHT	ON
STEPS/RAMP	3
STEP/RAMP TIME	5

**EXIT MENU** - exits this menu immediately and saves any changes. Menu will automatically exit after 15 seconds of inactivity.

**AUTO OFF** - If AUTO OFF is ON, the unit will turn off after 30 minutes of inactivity to save battery life. If AUTO OFF is OFF the unit will stay on until the POWER SWITCH is moved to the off position.

**BACKLIGHT** - If BACKLIGHT is ON the backlight will light all the time the unit is powered up. For maximum battery life turn the backlight off when using the calibrator in areas with enough ambient light to read the display.

**STEPS/RAMP** - pressing the knob will cycle through 2, 3, 5, 11 and RAMP. The endpoints of the steps or ramp are based on the values stored in the HI and LO EZ-CHECK outputs.

**2 steps** will automatically switch between the values stored in the HI & LO EZ-CHECK (0 & 100%).

**3 steps** between the HI, Midpoint and LO EZ-CHECK (0, 50 & 100%).

**5 steps** between the HI and LO EZ-CHECK in 25% increments (0, 25, 50, 75 & 100%).

**11 steps** between the HI and LO EZ-CHECK in 10% increments (0, 10, 20...80, 90 & 100%).

**RAMP** continuously ramps up and down between the HI and LO EZ-CHECK outputs.

**STEP/RAMP TIME** - pressing the knob will cycle through 5, 6, 7, 8, 9, 10, 15, 20, 25, 30 and 60 seconds.

#### To start the Automatic Stepping

Start automatic stepping or ramping by placing the EZ-CHECK Switch into the HI or LO position then press and hold the ③ DIAL KNOB for 6 seconds (the word STORE will appear on the display after 3 seconds and continue to press the EZ-DIAL KNOB) until the word STEP appears on the display. The word STEP will appear on the display anytime the selected automatic function is running. Stop the stepping or ramping by again pressing and holding the ③ DIAL KNOB for 3 seconds.

## Storing EZ-CHECK Outputs

### STORING HI and LO EZ-CHECK Outputs

Choose this function to provide a simulated thermocouple signal into controllers, temperature transmitters, indicators or any other input device that measure thermocouple sensors.

- 1) Store your high (SPAN) output temperature by moving the EZ-CHECK switch to the **HI** position and turn the ③ EZ-Dial knob until the desired temperature is on the display. Press and hold the EZ-Dial knob until **STORED** appears to store the value. Release the EZ-Dial knob.
- 2) Store your low (ZERO) output temperature by moving the EZ-CHECK switch to the **LO** position and turn the ③ EZ-Dial knob until the desired temperature is on the display. Press and hold the EZ-Dial knob until **STORED** appears to store the value. Release the EZ-Dial knob.
- 3) Instantly output your SPAN and ZERO temperature outputs by moving the EZ-CHECK switch between HI and LO. You may also select any third temperature output (such as mid-range) using the SET position on the EZ-CHECK switch.

## Automatic Stepping

### To change the Automatic Stepping settings

Double click the ③ DIAL KNOB at any time the unit is on and the menu will appear for 15 seconds.

Turn the ③ DIAL KNOB to move through down to the third (FEATURES) menu. Press the ③ DIAL KNOB to toggle between OFF and ON or to change the STEPS and the STEP TIME settings. These settings are remembered even with the power off.

FEATURES	
> EXIT (3/3)	
AUTO OFF	ON OFF
BACKLIGHT	ON OFF
STEPS/RAMP	2 3 5 11 RAMP
STEP/RAMP TIME	5 6 7 8 9 10 15 20 25 30 60

**EXIT MENU** - exits this menu immediately and saves any changes. Menu will automatically exit after 15 seconds of inactivity.

**STEPS** - pressing the knob will cycle through 2, 3, 5 and 11 then reverse direction. The endpoints of the steps are based on the values stored in the **HI** and **LO** EZ-CHECK outputs.

**2 steps** will automatically switch between the values stored in the HI & LO EZ-CHECK (0 & 100%).

**3 steps** between the HI, Midpoint and LO EZ-CHECK (0, 50 & 100%).

**5 steps** between the HI and LO EZ-CHECK in 25% increments (0, 25, 50, 75 & 100%).

**11 steps** between the HI and LO EZ-CHECK in 10% increments (0, 10, 20...80, 90 & 100%).

**RAMP** continuously between the HI and LO EZ-CHECK.

**STEP TIME** - pressing the knob will cycle through 5, 6, 7, 8, 9, 10, 15, 20, 25, 30 and 60 seconds.

### To start the Automatic Stepping

Start automatic stepping or ramping by placing the EZ-CHECK Switch into the HI or LO position then press and hold the ③ DIAL KNOB for 6 seconds (the word STORE will appear on the display after 3 seconds and continue to press the DIAL KNOB) until the word STEPPING appears on the display. The word STEPPING will appear on the display anytime the selected automatic function is running. Stop the stepping by again pressing and holding the ③ DIAL KNOB for 3 seconds.

## Operating Instructions

### Calibrate a 2-Wire Transmitter by sourcing the input while monitoring the output.

Works with SOURCE pH, T/C, DC V, OHMS, RTD, FREQ and READ PRESSURE.

Move the power switch ② to READ and Double click the ③ DIAL KNOB and the MAIN menu for the function in use will appear for 15 seconds:

MAIN	
> EXIT	
FUNCTION	T/C
UNITS	°C
T/C TYPE	K
COLD JUNC	ON

Turn the ③ DIAL KNOB to move to the second (or third) menu page so the word **mA DISPLAY** appears at the top of the menu.

mA DISPLAY	
> EXIT	
MODE	OFF READ PWRM READ% PWRM%
HART 250Ω	OFF ON
LEAK DETECT	OFF

Turn the ③ DIAL KNOB to move through the menu. Press the ③ DIAL KNOB to toggle between OFF and ON or to change the MODE setting.

**HART 250Ω** - turn on the 250Ω resistor if you are powering up a HART transmitter. This provides the loop load required for HART communication.

**EXIT MENU** - exits this menu immediately and saves any changes. Menu will automatically exit after 15 seconds of inactivity.

**MODE** - pressing the knob will cycle through READ, PWRM, READ% ,PWRM% and OFF.

**READ** turns on the mA display and indicates current passing through the loop proportional to the input of the transmitter which is controlled by the output of the 830PM. Choose **READ%** if your would like the mA display in percent of 4-20 milliamps.

**PWRM** is POWER MEASURE which uses the internal loop supply of the 830PM to power up the transmitter while indicating the current passing through the loop proportional to the input of transmitter which is controlled by the output of the 830PM. Choose **PWRM%** if your would like the mA display in percent of 4-20 milliamps.

If **PWRM** or **PWRM%** is selected an additional menu selection of **LEAK DETECT** will appear. When **LEAK DETECT** is turned on the 830PM will display **LEAK** on the display if there is more than 0.015 mA of uncontrolled current in the loop. This may be due to a faulty transmitter, corrosion causing a bridge to ground or moisture present at some connection point. When **LEAK DETECT** tests a loop with leakage the loop mA signal will be affected.



# Operating Instructions

Calibrate a 2-Wire Transmitter by sourcing the input while monitoring the output.

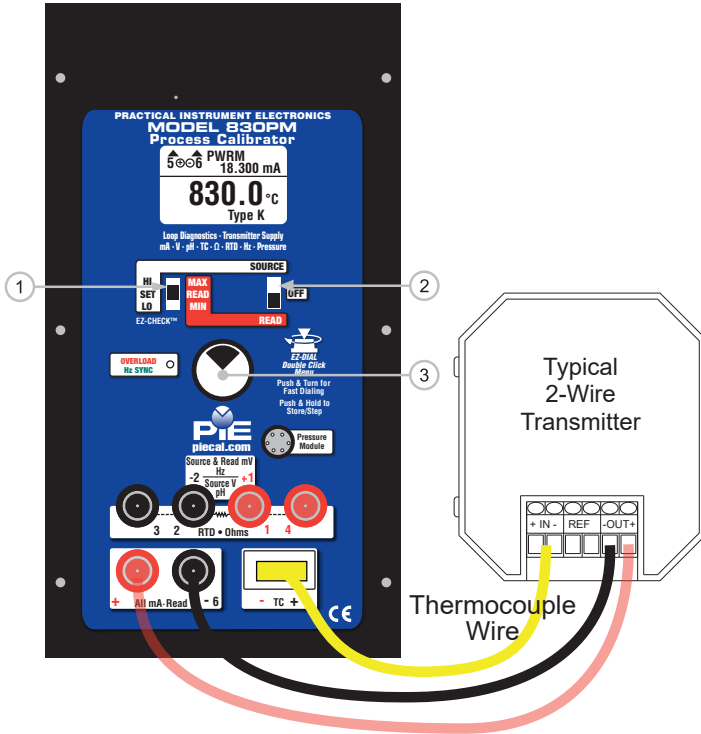

**PWRM LEAK**  
18.300 mA  
**830.0 °C**  
**TYPE K**

(Enlarged Display of the 830PM detecting a current leakage in the loop)

Practical Instrument Electronics

Tel: 585.872.9350 • Fax: 585.872.2638 • sales@piecal.com • www.piecal.com

## Operating Instructions

### Universal Isolated Transmitter

#### Swap out a transmitter to diagnose control issues.

The 830PM acts as an isolated universal T/C, mV, OHMS, RTD, FREQ and PRESSURE transmitter. Choose this function to temporarily replace a transmitter when you suspect the transmitter is faulty or to diagnose the parameters of the loop.

Move the power switch ② to READ and Double click the ③ DIAL KNOB and the MAIN menu for the function in use will appear. Turn the ③ DIAL KNOB until the pointer is at FUNCTION and press the ③ KNOB until the desired FUNCTION appears.

Turn the ③ DIAL KNOB to move through the menu. Press the ③ DIAL KNOB to toggle the units, range, T/C Type or RTD curve.

MAIN	
> EXIT	
FUNCTION	T/C
UNITS	°C
T/C TYPE	K
COLD JUNC	ON

MAIN	
> EXIT	
FUNCTION	RTD
UNITS	°C
RTD	Pt 100 $\alpha=3850$

MAIN	
>EXIT	
FUNCTION	V
RANGE	100mV

MAIN	
>EXIT	
FUNCTION	OHMS
RANGE	400 $\Omega$

MAIN	
> EXIT	
FUNCTION	FREQ
RANGE	20KHZ

MAIN	
>EXIT	
FUNCTION	PRESSURE
UNITS	psi

Turn the ③ DIAL KNOB to move to the second (or third) menu page so the word **XXX XMTR** appears at the top of the menu.

Turn the ③ DIAL KNOB to move through the menu. Press the ③ DIAL KNOB to toggle between DOWN and UP, OFF and ON, or to change the MODE setting.

XXX XMTR	
> EXIT	
MODE	OFF LINEAR NONLINEAR SQ ROOT
BURNOUT	DOWN UP
LOOPSCOPE	OFF ON

## Operating Instructions

**MODE** - pressing the knob will cycle through OFF, LINEAR, NONLINEAR. When setup to read pressure SQ ROOT replaces NONLINEAR.

**LINEAR** turns on the mA display and regulates the loop current linear with the input signal. For thermocouples & RTDs this is linear relative to the temperature between zero and span of the sensor input. This mimics the operation of a digital temperature transmitter or other linearizing transmitters.

**NONLINEAR** (applies only to thermocouples and RTDs) turns on the mA display and regulates the loop current linear with base units (millivolts or ohms) of zero and span of the sensor input. This mimics the operation of an analog temperature transmitter without linearizing.

**SQ ROOT** turns on the mA display and regulates the loop current with square root extraction of zero and span of the pressure module input. This mimics the operation of a differential pressure transmitter setup for square root extraction.

**BURNOUT** selects the failure mode of the calibrator when the input signal is lost or beyond the input scale. **Down** sets the output to 1.0 mA and **UP** to 21.5 mA when sensor failure is detected.

**LOOPSCOPE** turns on the Loop Diagnostic display which simultaneously indicates the current, voltage and resistance of the loop. When enabled the **LOOPSCOPE** also indicates errors by flashing the LED and writing diagnostic messages on the display. Messages include **LOW LOOP VOLT, HIGH LOOP VOLT** and **HIGH LOOP IMPED**. With LOOPSCOPE on the 830PM occasionally performs a test on the loop. During this short test the loop mA signal will be affected.

### Setting up the 830PM as a transmitter

Configure your 830PM to the same Span (URV) and Zero (LRV) by storing Span & Zero setting with the ① EZ-CHECK switch.

- 1) Store your SPAN input by moving the ① EZ-CHECK switch to the **MAX** position and turning the ③ EZ-Dial knob until the desired output value is on the display. Press and hold the EZ-Dial knob until **STORED** appears to store the value. Release the EZ-Dial knob.
- 2) Store your ZERO input by moving the EZ-CHECK switch to the **MIN** position and turning the EZ-Dial knob until the desired output value is on the display. Press and hold the EZ-Dial knob until **STORED** appears to store the value. Release the EZ-Dial knob.
- 3) Move the EZ-CHECK switch to the **READ** position. The 830PM constantly measures the input from the process sensor and regulates the current in the 4-20 mA loop.

Once the 830PM is setup and connected to the process sensor and the 4-20 mA loop it acts just like a calibrated isolated transmitter and will display the input signal from the sensor and the regulated 4-20 mA output signal. XMTR is shown on the display along with L, N or S for Linear, Nonlinear or Square Root respectively.

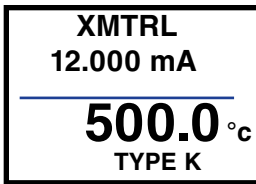

830PM as a Transmitter

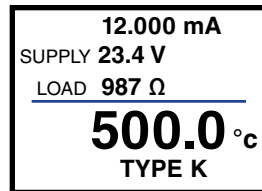

830PM with LOOPSCOPE

For full loop diagnostics turn on LOOPSCOPE which indicates the current, SUPPLY (voltage) and LOAD (resistance) of the loop. It also indicates errors by flashing the LED and writing diagnostic messages including **LOW LOOP VOLT**, **HIGH LOOP VOLT** and **HIGH LOOP IMPED**.

## Operating Instructions

### Connecting the 830PM in place of a transmitter

Connect the 830PM in place of the transmitter. The 4-20 mA loop connects to the mA jacks of the 830PM and the sensor (or pressure module) connects to the other jacks of the 830PM.

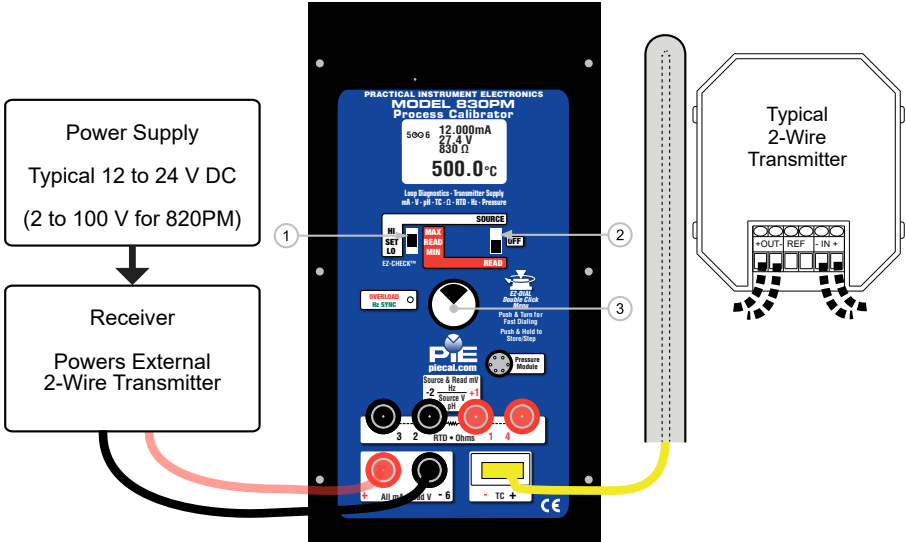

Note: With LOOPSCOPE on the 830PM occasionally performs a test on the loop. During this short test the loop mA signal will be affected.

## Operating Instructions

### 2 Wire SIM mA, 2 Wire SIM % (Percent of 4 to 20 mA)

Choose this function to simulate a 2 Wire Transmitter output from 0.000 to 24.000 milliamps. Operates in loops with power supply voltages from 2 to 60 VDC.

Move the power switch ② to SOURCE then Double Click the EZ-DIAL knob to get into the Menu. Turn the knob to scroll through the settings and press the knob to make your selection. Select mA for the FUNCTION and 2W SIM for the MODE. Choose either mA or % and whether you need the 250Ω HART resistor active in the loop.

If you would also like to see the condition of the loop turn the ③ DIAL KNOB to move to the second (or third) menu page so the word **mA DIAGNOSTIC** appears at the top of the menu.

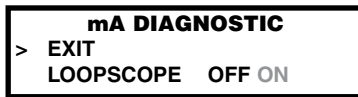

**LOOPSCOPE** turns on the Loop Diagnostic display which simultaneously indicates the current, voltage and resistance of the loop. When enabled the **LOOPSCOPE** also indicates errors by flashing the LED and writing diagnostic messages on the display. Messages include **LOW LOOP VOLT**, **HIGH LOOP VOLT** and **HIGH LOOP IMPED**. With **LOOPSCOPE** on the 830PM occasionally performs a test on the loop. During this short test the loop mA signal will be affected.

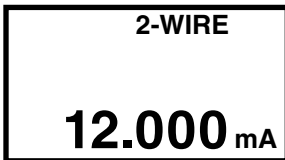

830PM Simulating a Transmitter

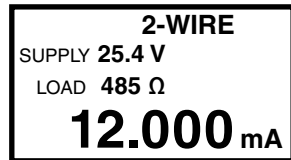

830PM with LOOPSCOPE

## Operating Instructions

### 2 Wire SIM mA, 2 Wire SIM % (Percent of 4 to 20 mA)

Connect the output leads of the 830PM to the inputs of the device being calibrated, making sure to check polarity. Red lead from jack (5) to the plus (+) input and black lead from jack (6) to the minus (-) input. Open loops and signals above the maximum scale are limited by protection circuitry with "ERROR" or "OVER RANGE" flashed on the display and the red OVERLOAD LED lit.

Instantly output your SPAN and ZERO output settings by moving the EZ-CHECK switch between HI and LO (defaults to 20 & 4 mA). You may also select any third output setting (such as mid-range) using the SET position on the EZ-CHECK switch. The output is adjusted in 0.001 mA (0.01%) increments by turning the knob ③. Press and turn the knob for faster dialing with 0.100 mA (1.00%) increments.

Note: With LOOPSCOPE on the 830PM occasionally performs a test on the loop. During this short test the loop mA signal will be affected.

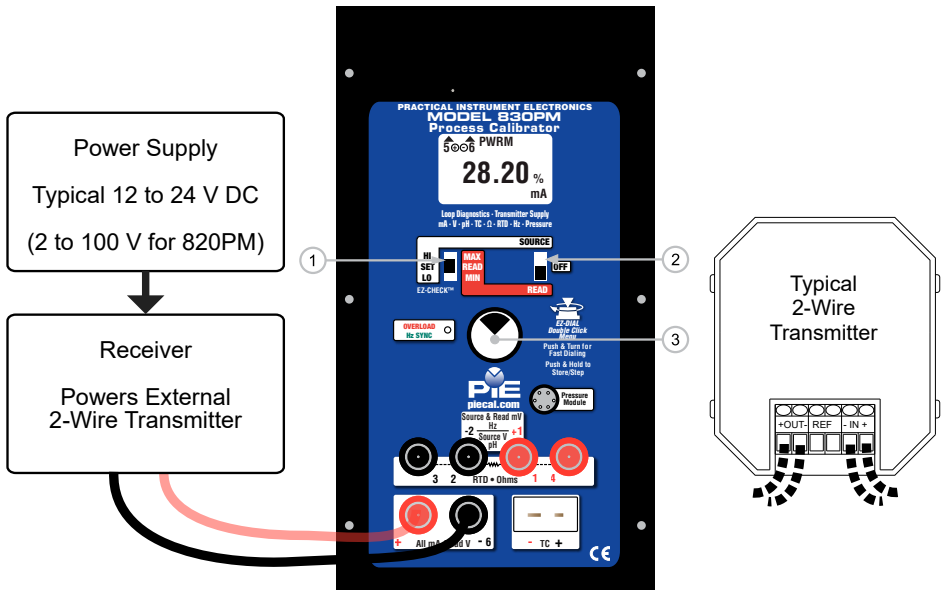

## Operating Instructions

### SOURCE mA / SOURCE % (Percent of 4 to 20 mA)

Choose this function to provide an output from 0.000 to 24.000 milliamps or -25.00 to 125.00%. The compliance voltage is a nominal 24 VDC to provide the driving power to your milliamp receivers.

Move the power switch ② to SOURCE then Double Click the EZ-DIAL knob to get into the Double Click Menu. Turn the knob to scroll through the settings and press the knob to make your selection. Select mA for the FUNCTION and SOURCE for the MODE. Choose either mA or % and whether you need the 250Ω HART resistor active in the loop.

Connect the output leads of the 830PM to the inputs of the device being calibrated, making sure to check polarity. Red lead from jack (5) to the plus (+) input and black lead from jack (6) to the minus (-) input. Open loops and signals above the maximum scale are limited by protection circuitry with “ERROR” or “OVER RANGE” flashed on the display and the red OVERLOAD LED lit.

Instantly output your SPAN and ZERO output settings by moving the EZ-CHECK switch between HI and LO (defaults to 20 & 4 mA). You may also select any third output setting (such as mid-range) using the SET position on the EZ-CHECK switch. The output is adjusted in 0.001 mA (0.01%) increments by turning the knob ③. Press and turn the knob for faster dialing with 0.100 mA (1.00%) increments.

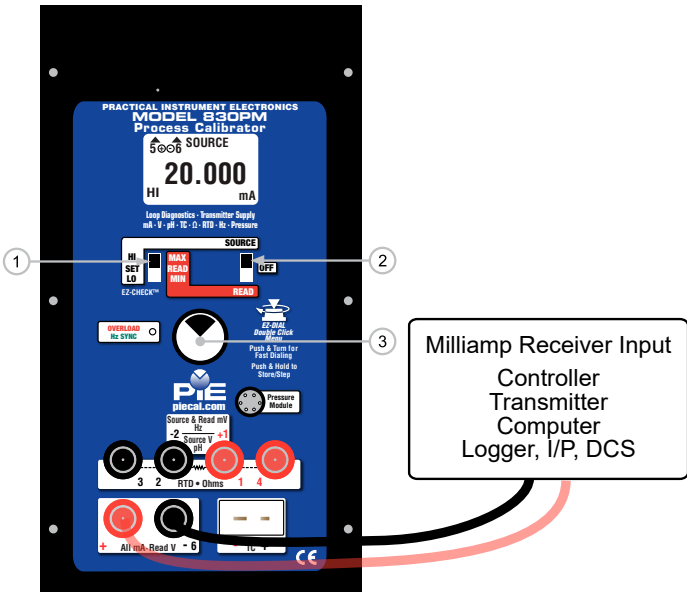

Practical Instrument Electronics

Tel: 585.872.9350 • Fax: 585.872.2638 • sales@piecal.com • www.piecal.com



## Operating Instructions

### READ mA, READ % (Percent of 4 to 20 mA)

Choose this function to measure from from 0.000 to 24.000 milliamps or -25.00 to 125.00%.

Move the power switch ② to READ then Double Click the EZ-DIAL knob to get into the Double Click Menu. Turn the knob ③ to scroll through the settings and press the knob to make your selection. Select mA for the FUNCTION and READ for the MODE. Choose either mA or % and whether you need the 250Ω HART resistor active in the loop.

Connect the red input lead from jack (5) of the 830PM to the more positive point of the break and the black input lead from jack (6) to the more negative point.

Signals below 0 mA or open circuits are indicated by 0.000 mA (-25.00%) on the display. Signals above 24 mA are current limited by protection circuitry with "OVER RANGE" on the display and the red OVERLOAD LED lit.

The 830PM measures the input signal and constantly updates the display with the current reading. Move the EZ-CHECK switch ① to MAX to see the highest reading and to MIN to see the lowest reading. Press and hold the knob ③ to clear the MAX and MIN readings.

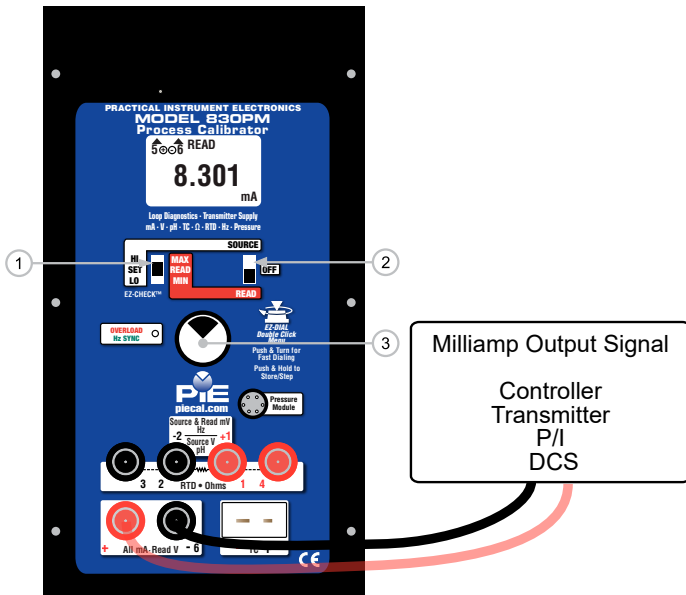

Practical Instrument Electronics

Tel: 585.872.9350 • Fax: 585.872.2638 • sales@piecal.com • www.piecal.com

## Operating Instructions

### Power/Measure mA, Power/Measure % (Percent of 4 to 20 mA)

Choose this function to simultaneously supply power to a 2 Wire Transmitter while displaying the 4 to 20 mA output of the transmitter.

Move the power switch ② to READ then Double Click the EZ-DIAL knob to get into the Double Click Menu. Turn the knob ③ to scroll through the settings and press the knob to make your selection. Select mA for the FUNCTION and PWR MEAS for the MODE. Choose either mA or % and whether you need the 250Ω HART resistor active in the loop.

Disconnect one or both input wires from the device to be calibrated. Connect the red source lead of the 830PM from jack (5) to the plus (+) input of the device and the black source lead from jack (6) to the minus (-).

The 830PM supplies a nominal 24 volts DC at 24 mA to the 2 Wire Transmitter. The current passed by the transmitter will be accurately displayed by the 830PM. Calibrate the transmitter in the usual manner and disconnect the 830PM. Signals above 24 mA are current limited by protection circuitry with "OVER RANGE" on the display and the red OVERLOAD LED lit.

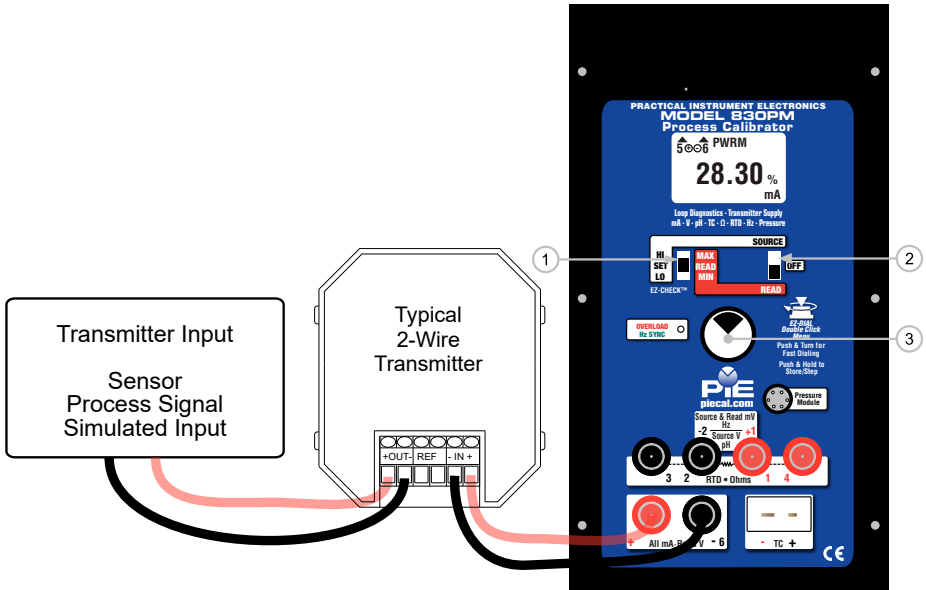

Practical Instrument Electronics

Tel: 585.872.9350 • Fax: 585.872.2638 • sales@piecal.com • www.piecal.com

**mA OUT, % OUT (Percent of 4 to 20 mA)**

Find current leaks in loops caused by ground faults, moisture or corrosion. The 830PM simultaneously supplies power to a 2 Wire Transmitter (or loop with a transmitter) while displaying the 4 to 20 mA output and the amount of current leaking in the loop.

- 1) Move the power switch ② to READ then Double Click the EZ-DIAL knob to get into the Menu. Turn the knob ③ to scroll through the settings and press the knob to make your selection. Select mA for the FUNCTION and PWR MEAS for the MODE. Choose either mA or %.
- 2) Turn the knob ③ until the following menu appears.
- 3) Turn the knob ③ to scroll through the settings and press the knob to make



your selection. Turn on the LEAK DETECT.

- 4) Connect the red source lead from the mA (+) jack of the 830PM to the plus (+) input of the device and the black source lead from the mA (-) to the minus (-).

The 830PM supplies a nominal 24 volts DC at 24 mA to the 2 Wire Transmitter or loop. The current passed by the transmitter will be accurately displayed by the 830PM along with an indication of leakage current at the top of the display. If there is an uncontrolled loop, a transmitter with upscale burnout and bad or missing sensor or a short the display shows "OVER RANGE"

# Operating Instructions

## Using Ground Leak Detection

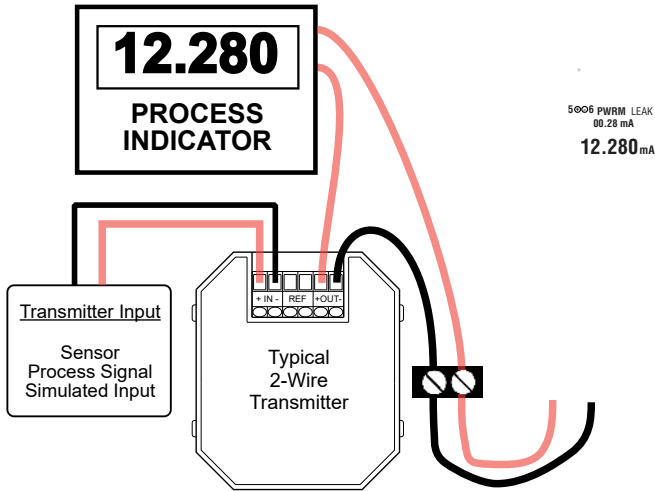

### Typical Error Conditions

PWRM LEAK  
00.28 mA  
**12.280** mA

The 830PM is supplying the loop voltage. A calibrated transmitter is limiting the loop current to 12.00 mA. An additional 0.28 mA is not controlled by the transmitter and is leaking somewhere in the loop.

PWRM LEAK  
mA  
OVER RANGE  
mA

The 830PM is supplying the loop voltage. There is a control loop error. This may be a transmitter (set for upscale burnout) with a bad or missing sensor, or a short in the loop.

**Note:** Many installed transmitters will normally indicate 0.01 to 0.02 mA leakage without significant control problem. Unstable readings may indicate loose connections or the presence of moisture.

## Operating Instructions

### SOURCE mV / V

Choose this function to provide an output from -20.000 to 99.999 mV, -500.00 to 999.99 mV or from 0.000 to 10.250 V. The source current is a nominal 20 mA to provide the driving power to your voltage receivers.

Move the power switch ② to SOURCE then Double Click the EZ-DIAL knob to get into the Double Click Menu. Turn the knob to scroll through the settings and press the knob to make your selection. Select V for the FUNCTION and 1V, 10V or 100 mV for the RANGE.

Connect the output leads of the 830PM to the inputs of the device being calibrated, making sure to check polarity. Connect the Red lead from jack (1) to the plus (+) input and black lead from jack (2) to the minus (-) input.

Instantly output your SPAN and ZERO output settings by moving the EZ-CHECK switch between HI and LO. You may also select any third output setting (such as mid-range) using the SET position on the EZ-CHECK switch. The output is adjusted in 0.001 mV, 0.01 mV or 0.001 V increments by turning the knob e. Press and turn the knob for faster dialing with 0.100 mV, 1.00 mV or 0.100 V increments.

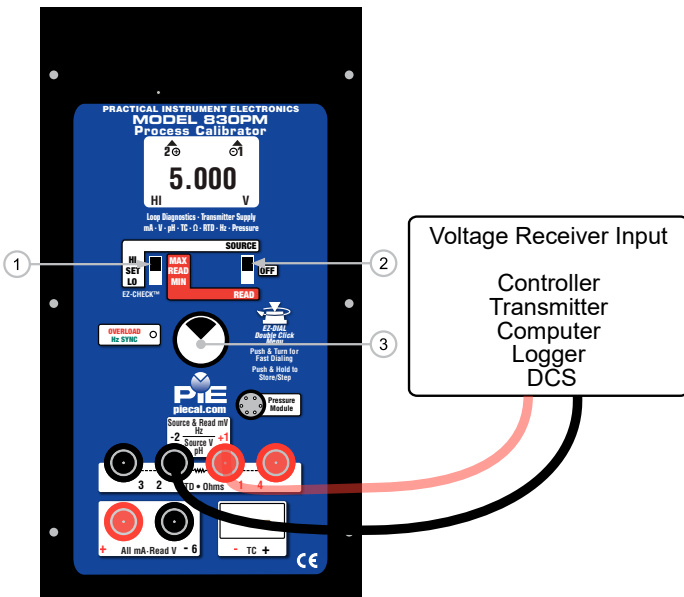

Practical Instrument Electronics

Tel: 585.872.9350 • Fax: 585.872.2638 • sales@piecal.com • www.piecal.com

# Operating Instructions

## Read mV / V

Choose this function to measure from -99.999 to 99.999 millivolts, -999.99 to +999.99 mV, 0.000 to 10.250 V dc or 0.00 to 60.00 V dc.

Move the power switch to READ then Double Click the EZ-DIAL knob to get into the Menu. Turn the knob to scroll through the settings and press the knob to make your selection. Select V for the FUNCTION and 1V, 10V, 60V or 100 mV for the RANGE.

Connect the red input lead (+) of the 830PM to the more positive point of the break and the black input lead to the more negative point. When measuring up to 100 mV connect the red lead to jack (1) and the black lead to jack (2). When measuring up to 1V, 10 V or 60 V connect the red lead to jack (5) and the black lead to jack (6).

Signals above the maximum scale are limited by protection circuitry with "OVER RANGE" on the display and the red OVERLOAD LED lit.

The 830PM measures the input signal and constantly updates the display with the current reading. Move the EZ-CHECK switch ① to MAX to see the highest reading and to MIN to see the lowest reading. Press and hold the knob ③ to clear the MAX and MIN readings.

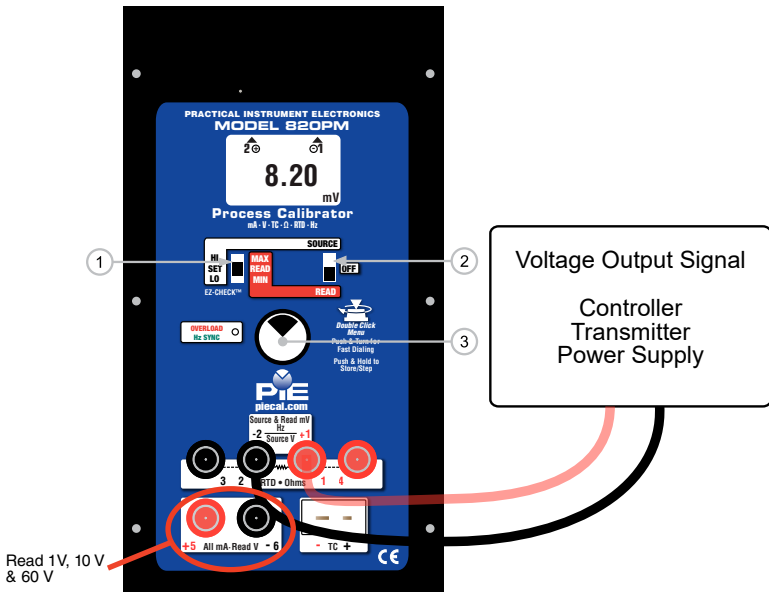

Practical Instrument Electronics

Tel: 585.872.9350 • Fax: 585.872.2638 • sales@piecal.com • www.piecal.com

## Operating Instructions

### pH SOURCE

Choose this function to provide an output from 0.000 to 14.000 pH @ 25°C (77°F) which corresponds to 414.12 to -414.12 mV. The source current is a nominal 20 mA to provide the driving power to your pH receivers.

Move the power switch ② to SOURCE then Double Click the EZ-DIAL knob to get into the Menu. Turn the knob to scroll through the settings and press the knob to make your selection. Select pH for the FUNCTION.

Connect the output leads of the 830PM to the inputs of the device being calibrated, making sure to check polarity. Red lead from the mV (+) jack of the 830PM to the plus (+) input and black lead from the mV (-) jack to the minus (-) input.

Instantly output your SPAN and ZERO output settings by moving the EZ-CHECK switch between HI and LO. You may also select any third output setting (such as mid-range) using the DIAL position on the EZ-CHECK switch. The output is adjusted in 0.001 pH increments by turning the knob ③. Press and turn the knob for faster dialing with 0.100 pH increments.

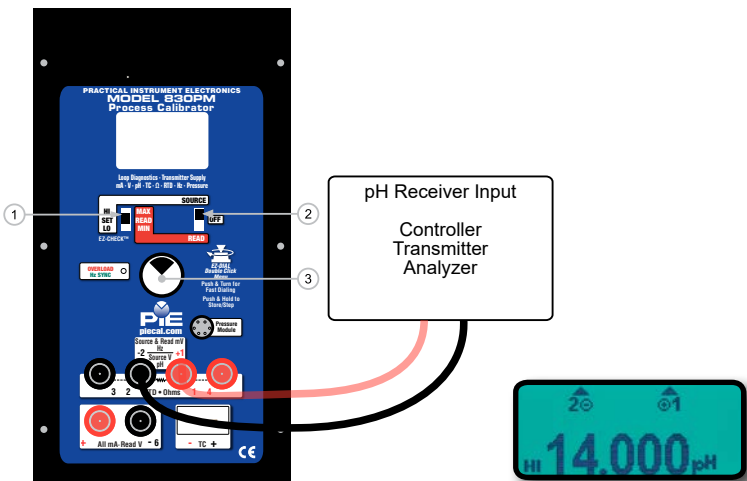

### Simulate pH probes into transmitters & analyzers

Use the pH simulator to verify proper operation of pH devices before you place a probe into a calibrated buffer. Adjusting the pH transmitter or analyzer without a probe allows you to make sure the device is calibrated and operating correctly. The 830PM simulates 0.000 to 14.000 pH @ 25°C corresponding to 414.12 to -414.12 mV.

Once the pH instrument has been adjusted against the 830PM reconnect the pH probe and check it against the proper buffer (typically 7 pH). If the instrument zero point requires more than the manufacturer's recommendations (typically within 0.5 pH) it is time to clean or replace the probe.

Practical Instrument Electronics

Tel: 585.872.9350 • Fax: 585.872.2638 • sales@piecal.com • www.piecal.com

## Operating Instructions

### Source Thermocouple

Choose this function to provide a simulated thermocouple signal into controllers, temperature transmitters, indicators or any input devices that measure thermocouple sensors.

Move the power switch ② to SOURCE then Double Click the EZ-DIAL knob to get into the Double Click Menu. Turn the knob to scroll through the settings and press the knob to make your selection. Select T/C for the FUNCTION, °F or °C for the UNITS, T/C Type (J, K, T, E, R, S, B, N, G, C, D, L (J-DIN), U (T-DIN) or P (Platinel II) and internal COLD JUNC ON or OFF (ON is the default).

Connect the 830PM to the inputs of the device being calibrated using the proper type of thermocouple wire via the miniature thermocouple socket.

Instantly output your SPAN and ZERO output settings by moving the EZ-CHECK switch between HI and LO. You may also select any third output setting (such as mid-range) using the SET position on the EZ-CHECK switch. The output is adjusted in 0.1° increments by turning the knob ③. Press and turn the knob for faster dialing with 10.0° increments.

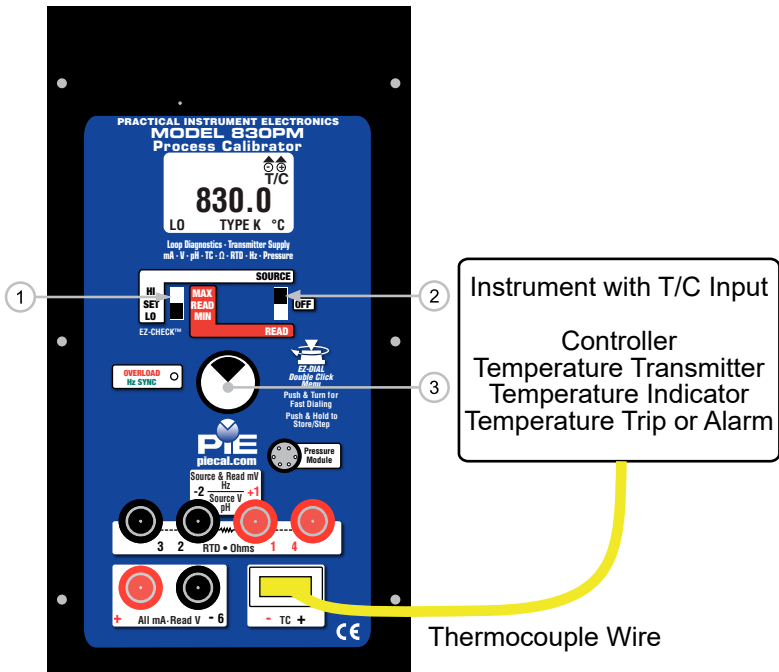

Practical Instrument Electronics

Tel: 585.872.9350 • Fax: 585.872.2638 • sales@piecal.com • www.piecal.com



## Operating Instructions

### Read Thermocouple Sensors

Choose this function to measure temperatures with a thermocouple probe or sensor.

Move the power switch ② to READ then Double Click the EZ-DIAL knob to get into the Double Click Menu. Turn the knob to scroll through the settings and press the knob to make your selection. Select T/C for the FUNCTION, °F or °C for the UNITS, T/C Type (J, K, T, E, R, S, B, N, G, C, D, L (J-DIN), U (T-DIN) or P (Platinel II) and COLD JUNC ON or OFF (ON is the default).

Connect the 830PM to the inputs of the device being calibrated using the proper type of thermocouple wire via the miniature thermocouple socket. If no sensor is connected, a wire is broken or the sensor is burned out, OPEN TC will appear on the display. Signals above the maximum scale are limited by protection circuitry with "OVER RANGE" on the display and the red OVERLOAD LED lit.

The 830PM measures the input signal and constantly updates the display with the current reading. Move the EZ-CHECK switch ① to MAX to see the highest reading and to MIN to see the lowest reading. Press and hold the knob ③ to clear the MAX and MIN readings.

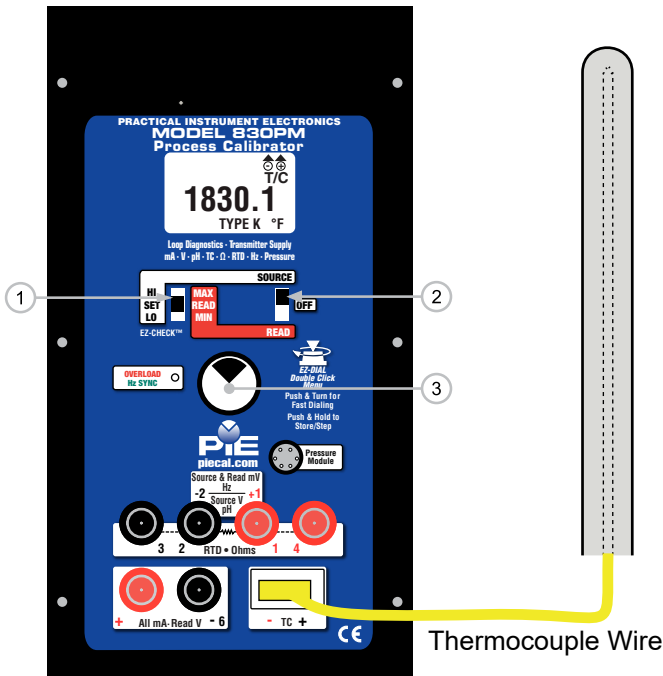

Practical Instrument Electronics

Tel: 585.872.9350 • Fax: 585.872.2638 • sales@piecal.com • www.piecal.com

## Operating Instructions

### Source Resistance

Choose this function to provide a simulated resistance into any device that measures resistance.

Move the power switch ② to SOURCE then Double Click the EZ-DIAL knob to get into the Double Click Menu. Turn the knob to scroll through the settings and press the knob to make your selection. Select OHMS for the FUNCTION, 400 $\Omega$  or 4000 $\Omega$  for the RANGE.

Disconnect all sensor wires from the devices to be calibrated and connect the 830PM to the inputs of the device using 2, 3 or 4 wires. For 2 Wire resistance connect the read lead into jack (1) and the black lead into jack (2). For 3 wire resistance add a black lead plugged into jack (3) and for 4 wire resistance add a red lead plugged into jack (4).

Instantly output your SPAN and ZERO output settings by moving the EZ-CHECK switch between HI and LO. You may also select any third output setting (such as mid-range) using the SET position on the EZ-CHECK switch. The output is adjusted in 0.01 $\Omega$ /0.1 $\Omega$  increments by turning the knob ③. Press and turn the knob for faster dialing with 1.00 $\Omega$ /10.0 $\Omega$  increments.

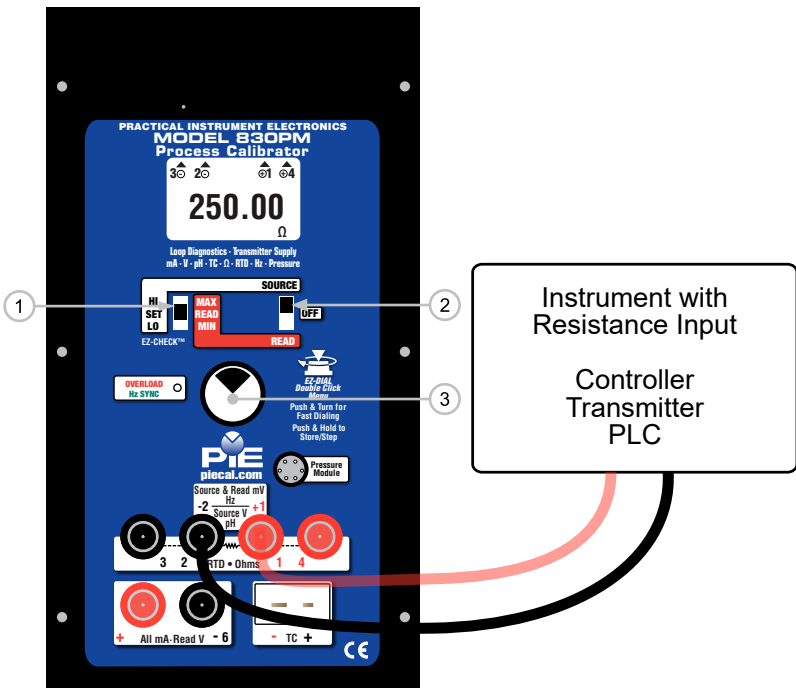

Practical Instrument Electronics

Tel: 585.872.9350 • Fax: 585.872.2638 • sales@piecal.com • www.piecal.com

## Operating Instructions

### Read Resistance & Check Continuity

Choose this function to measure resistance or check continuity.

Move the power switch ② to READ then Double Click the EZ-DIAL knob to get into the Double Click Menu. Turn the knob to scroll through the settings and press the knob to make your selection. Select OHMS for the FUNCTION, 400Ω, 4000Ω or Continuity for the RANGE.

Disconnect all wires from the sensor and connect the 830PM to the resistor or sensor using 2, 3 or 4 wires. The 830PM automatically detects how many wires are connected using a patented circuit and indicates each wire that is connected. Any wires that are not connected or broken are indicated by the 830PM. This is useful for troubleshooting the sensor.

If continuity is selected, resistance is measured up to 400.00Ω. The beeper will sound and )))) appears on the display when resistances < 100.00Ω are measured.

Signals above the maximum scale are limited by protection circuitry with "OVER RANGE" on the display and the red OVERLOAD LED lit.

The 830PM measures the input signal and constantly updates the display with the current reading. Move the EZ-CHECK switch ① to MAX to see the highest reading and to MIN to see the lowest reading. Press and hold the knob ③ to clear the MAX and MIN readings.

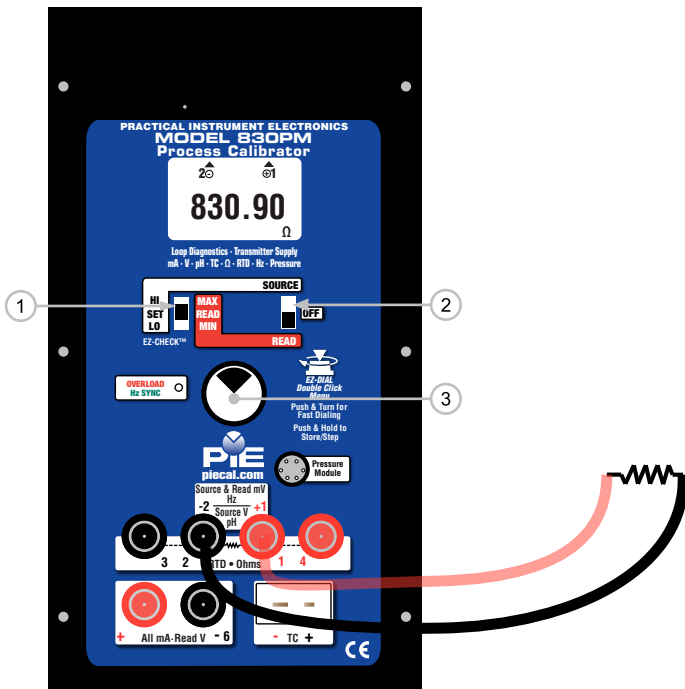

Practical Instrument Electronics

Tel: 585.872.9350 • Fax: 585.872.2638 • sales@piecal.com • www.piecal.com

## Operating Instructions

### Source RTD

Choose this function to provide a simulated RTD signal into controllers, temperature transmitters, indicators or any input devices that measure RTD sensors.

Move the power switch ② to SOURCE then Double Click the EZ-DIAL knob to get into the Double Click Menu. Turn the knob to scroll through the settings and press the knob to make your selection. Select RTD for the FUNCTION, °F or °C for the UNITS and RTD (Choose from one of Platinum 100Ω, or 1000Ω, Copper 10Ω or 50Ω, or Nickel 120Ω curves). *Note: Pt 100Ω 3850 is the most common RTD type.*

Disconnect all sensor wires from the devices to be calibrated and connect the 830PM to the inputs of the device using 2, 3 or 4 wires. For 2 Wire RTDs connect the red lead into jack (1) and the black lead into jack (2). For 3 wire RTDs add a black lead plugged into jack (3) and for 4 wire RTDs add a red lead plugged into jack (4).

Instantly output your SPAN and ZERO output settings by moving the EZ-CHECK switch between HI and LO. You may also select any third output setting (such as mid-range) using the SET position on the EZ-CHECK switch. The output is adjusted in 0.1° increments by turning the knob ③. Press and turn the knob for faster dialing with 10.0° increments.

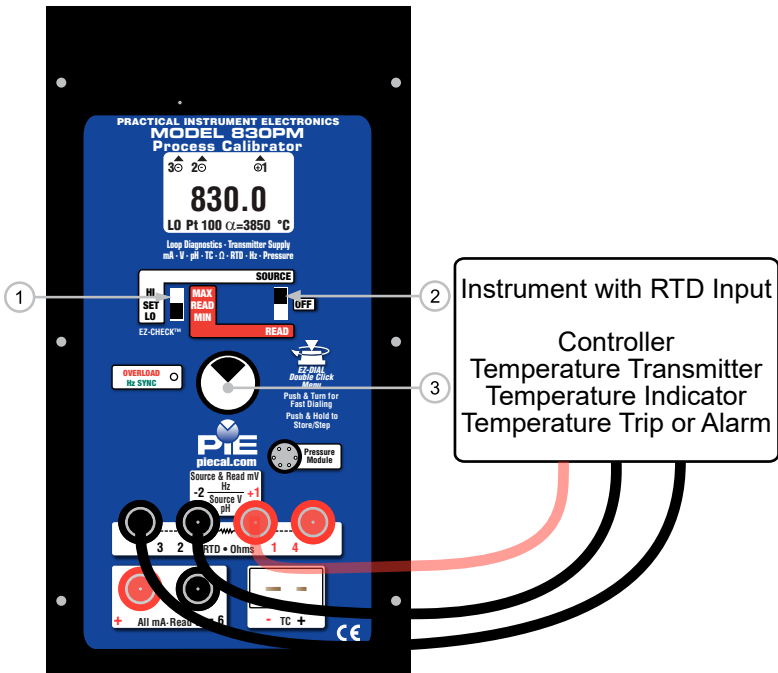

Practical Instrument Electronics

Tel: 585.872.9350 • Fax: 585.872.2638 • sales@piecal.com • www.piecal.com

## Operating Instructions

### Read RTD Sensors

Choose this function to measure temperatures with an RTD probe or sensor.

Move the power switch ② to READ then Double Click the EZ-DIAL knob to get into the Double Click Menu. Turn the knob to scroll through the settings and press the knob to make your selection. Select RTD for the FUNCTION, °F or °C for the UNITS and RTD (Choose from one of Platinum 100Ω, or 1000Ω, Copper 10Ω or 50Ω, or Nickel 120Ω curves). *Note: Pt 100Ω 3850 is the most common RTD type.*

Disconnect all wires from the sensor and connect the PIE 830PM to the inputs of the device using 2, 3 or 4 wires. For 2 Wire RTDs connect the read lead into jack (1) and the black lead into jack (2). For 3 wire RTDs add a black lead plugged into jack (3) and for 4 wire RTDs add a red lead plugged into jack (4). The PIE 830PM automatically detects how many wires are connected using a patented circuit and indicates each wire that is connected. Any wires that are not connected or broken are indicated by the 830PM. This is useful for troubleshooting the sensor.

Signals above the maximum scale are limited by protection circuitry with “OVER RANGE” on the display and the red OVERLOAD LED lit.

The 830PM measures the input signal and constantly updates the display with the current reading. Move the EZ-CHECK switch ① to MAX to see the highest reading and to MIN to see the lowest reading. Press and hold the knob ③ to clear the MAX and MIN readings.

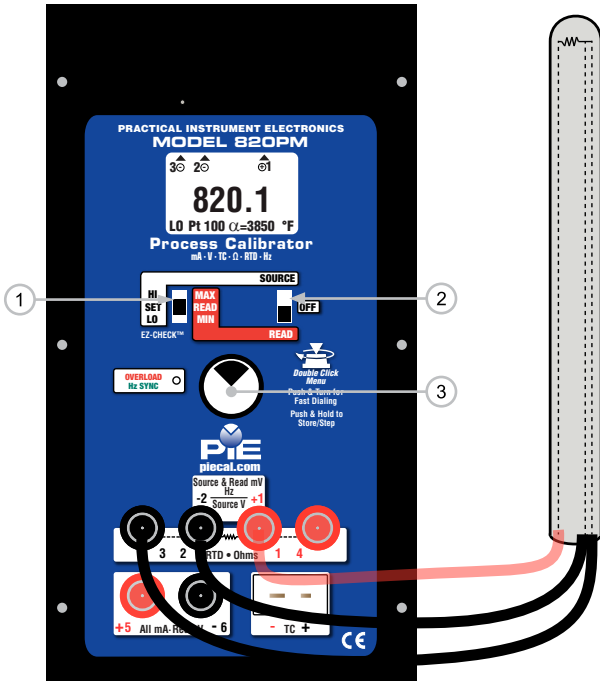

Practical Instrument Electronics

Tel: 585.872.9350 • Fax: 585.872.2638 • sales@piecal.com • www.piecal.com



# Operating Instructions

## Read Frequency

Choose this function to count frequency.

Move the power switch ② to READ then Double Click the EZ-DIAL knob to get into the Double Click Menu. Turn the knob to scroll through the settings and press the knob to make your selection. Select FREQ for the FUNCTION and 20KHZ, 10000HZ, 1000HZ or 2000CPM for the RANGE.

Disconnect all input wires from the devices to be calibrated and connect the 830PM to the output of the device matching polarity. 830PM to the input of the device matching polarity. Connect the Red lead from jack (1) to the plus (+) input and black lead from jack (2) to the minus (-) input.

The green HZ SYNC LED pulses in synch with the input frequency.

Signals above the maximum scale are limited by protection circuitry with "OVER RANGE" on the display and the red OVERLOAD LED lit.

The 830PM measures the input signal and constantly updates the display with the current reading. Move the EZ-CHECK switch ① to MAX to see the highest reading and to MIN to see the lowest reading. Press and hold the knob ③ to clear the MAX and MIN readings.

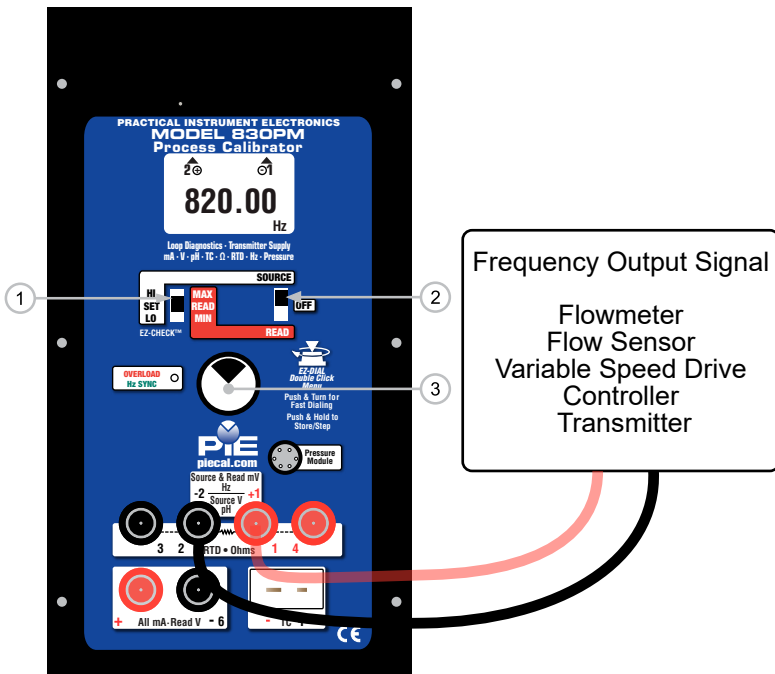

Practical Instrument Electronics

Tel: 585.872.9350 • Fax: 585.872.2638 • sales@piecal.com • www.piecal.com

## Operating Instructions

### Read Pressure

Choose this function to measure pressure in one of 32 different engineering units using a PIE Pressure Module.

1) Move the power switch ② to READ then Double Click the EZ-DIAL knob to get into the Menu. Turn the knob to scroll through the settings and press the knob to make your selection. Select PRESSURE for the FUNCTION and make your choice of UNITS to match the pressure instrument to be checked.

2) Remove the covers from the ends of the connector on the pressure module cable and the pressure connector of the 830PM. Align the white arrows and plug the cable into the 830PM.

3) Connect pressure hoses, fittings & pumps (if required) to the pressure instrument to be checked.

4) Press and hold the ③ E-Z DIAL KNOB for 2 seconds (after MAX/MIN RESET appears) to 'Zero' or 'Tare' the pressure. The display will briefly display 'TARE ON' then a '0' appears on the display indicating that all measurements are relative to the pressure measured when the calibrator was zeroed. Press and hold the ③ E-Z DIAL KNOB for 2 seconds (after MAX/MIN RESET appears) when you want to turn the 'Tare' off.

The 830PM measures the pressure and constantly updates the display with the current reading. Move the EZ-CHECK switch ① to MAX to see the highest reading and to MIN to see the lowest reading. Press and hold the knob ③ for 1 second to clear the MAX and MIN readings.

To disconnect the pressure module gently pull up on the grooved area just above the white arrow.

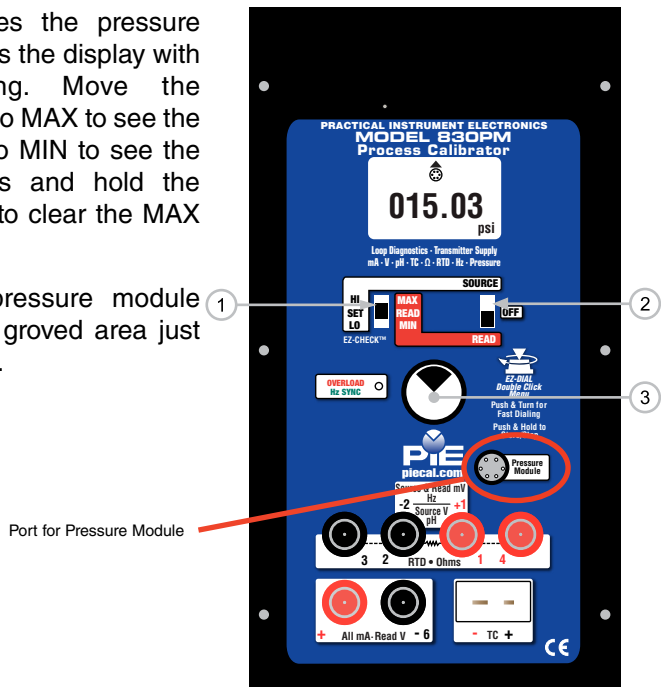

Practical Instrument Electronics

Tel: 585.872.9350 • Fax: 585.872.2638 • sales@piecal.com • www.piecal.com



### Optional Pressure Modules

Sensor Code	Application
<b>DNxxxx</b>	<b>Differential, Non-isolated</b>
0 to 0010*, 0028, 0200, 0415, 2000" H2O	
<b>DIxxxx</b>	<b>Differential, Isolated</b>
0 to 0001, 0005, 0015, 0030, 0100, 0300, 0500 PSID	
<b>GIxxxx</b>	<b>Gauge, Isolated</b>
0 to 0015, 0030, 0050, 0100, 0300, 0500, 1000, 3000 PSIG	
<b>CIxxxx</b>	<b>Compound, Isolated</b>
-14.7 to +0015, 0030, 0050, 0100, 0300, 0500, 1000, 3000 PSIG	
<b>AIxxxx</b>	<b>Absolute, Isolated</b>
0 to 0017, 0038, 0100, 1000 PSIA	

### Media Compatibility

Non-isolated DN sensors: clean, dry, non-corrosive, non-condensing gases only

Isolated DI sensors: any media compatible with 316L SS & Viton®

Isolated GI, CI & AI sensors: any media compatible with 316L SS

### Pressure Module Accuracy

±0.025% of full scale including all effects of linearity, repeatability and hysteresis from -20° to +50°C (-4° to +122°F)

\* The DN0010 sensor accuracy is ±0.050% of full scale

### 32 Engineering Units:

PSI • inches, feet, mm, cm and meter of H2O @ 4°C, 20°C & 60°F inches, meter, cm and mm of Hg @ 0°C

torr • kg/cm<sup>2</sup> • kg/m<sup>2</sup> • Pa • hPa • kPa • MPa • Bar • mBar • ATM • oz/in<sup>2</sup> • lb/ft<sup>2</sup>

## Pressure Module



Practical Instrument Electronics

Tel: 585.872.9350 • Fax: 585.872.2638 • sales@piecal.com • www.piecal.com



# Specifications

General	
Operating Temp Range	-20 to 60 °C (-5 to 140 °F)
Storage Temp Range	-30 to 60 °C (-22 to 140 °F)
Temperature effect	$\leq \pm 0.01 \% / ^\circ\text{C}$ of Full Scale; Cold Junction Sensor $\leq \pm 25 \text{ ppm}/^\circ\text{C}$
Relative Humidity Range	10 % $\leq$ RH $\leq$ 90 % (0 to 35 °C), Non-condensing
	10 % $\leq$ RH $\leq$ 70 % (35 to 60 °C), Non-condensing
Isolation: Voltage Common Mode	60V rms between all mA functions/Read V DC and Source V DC/ thermocouple/RTD/Ohms//Frequency/Pressure 50/60 Hz, 100 dB
Normal Mode Rejection	50/60 Hz, 50 dB
Noise	$\leq \pm 1/2$ Least Significant Digit from 0.1 to 10 Hz
Size	5.63x3.00x1.60" 143x76x41mm (LxWxH)
Weight	12.1 ounces, 0.34 kg with boot & batteries
Batteries	Four "AA" Alkaline 1.5V (LR6)
Battery life	Read Functions: $\geq 20$ hrs; Pressure $\geq 7$ hrs Source mA: $\geq 14$ hours @ 12 mA into 250 $\Omega$ Pwr/Meas mA: $\geq 12$ hours at 20 mA Source V, $\Omega$ , T/C, RTD & Hz: $\geq 20$ hours
Low Battery	Low battery indication with nominal 1 hour of operation left
Protection against misconnection	Over-voltage protection to 60 vrms (rated for 30 seconds) Red LED indicates OVERLOAD or out of range conditions
Display	High contrast graphic liquid crystal display, 0.315" (8.0 mm) high digits, backlighting

Read mA	
Ranges and Resolution	0.000 to 24.000 mA or -25.00 to 125.00% of 4-20 mA
Accuracy	$\leq \pm (0.02 \% \text{ of Reading} + 0.003 \text{ mA})$
Voltage burden	$\leq 2\text{V}$ at 24 mA
Overload/Current limit protection	25 mA nominal

Source mA / Power & Measure Two Wire Transmitters	
Ranges and Resolution	Same as Read mA
Accuracy	$\leq \pm (0.02 \% \text{ of Reading} + 0.003 \text{ mA})$
Loop compliance voltage	$\geq 24 \text{ DCV @ } 20.00\text{mA}$
Loop drive capability	1200 $\Omega$ at 20 mA for 15 hours nominal; 950 $\Omega$ with Hart Resistor enabled

mA 2-Wire Transmitter Simulation	
Accuracy	Same as Source/Power & Measure
Voltage burden	$\leq 2\text{V}$ at 20 mA
Overload/Current limit	24 mA nominal
Loop voltage limits	2 to 60 VDC (fuse-less protected)

Practical Instrument Electronics

Tel: 585.872.9350 • Fax: 585.872.2638 • sales@piecal.com • www.piecal.com

## Specifications

<b>DC Voltage Read</b>	
Ranges and Resolution	$\pm 99.999$ mV, $\pm 999.99$ mV, 0 to 10.250 V, 0.00 to 60.00 V DC
Accuracy	$\leq \pm (0.02 \% \text{ of Reading} + 0.01\% \text{ Full Scale})$
Input resistance	$\geq 1 \text{ M}\Omega$

<b>Source V dc</b>	
Ranges & Resolution	-20.000 to 99.999 mV, -500.00 to 999.99 mV, 0.000 to 10.250V
Accuracy	$\leq \pm (0.02 \% \text{ of Reading} + 0.01\% \text{ Full Scale})$
Source Current	$\geq 24 \text{ mA}$
Sink Current	$> 16 \text{ mA}$
Output Impedance	$< 1 \text{ Ohm}$
Short Circuit Duration	Infinite

<b>pH Source</b>	
Range and Resolution	-414.00 to +414.00 pH
Accuracy in mV	$\leq \pm (0.02 \% \text{ of Reading in mV} + 0.1 \text{ mV})$
Accuracy in pH	$\leq \pm 0.003 \text{ pH @ } 25^\circ\text{C}$

<b>Thermocouple Source</b>	
Accuracy	$\leq \pm (0.02 \% \text{ of Reading} + 0.01 \text{ mV})$
Cold Junction Compensation	$\pm 0.05^\circ\text{C}$ ; Thermistor traceable to NIST for 11 years
Output Impedance	$< 1 \text{ Ohm}$
Source Current	$> 20 \text{ mA}$ (drives 80 mV into 10 Ohms)

<b>Thermocouple Read</b>	
Accuracy & Cold Junction Compensation	Same as Thermocouple Source
Input Impedance	$> 1 \text{ Megohms}$
Open TC Threshold; Pulse	10K Ohms; $< 5 \mu\text{amp}$ pulse for 300 milliseconds (nominal)

<b>RTD, OHMS and Continuity Read</b>	
Resistance Ranges	0.00 to 401.00, 0.0 to 4010.0 Ohms
Accuracy	$\pm(0.025\% \text{ of Reading} + 0.075 \text{ Ohms})$
Excitation Current	1.0 mA to 401.0 Ohms, 0.5 mA to 4010 Ohms (nominal)
Continuity	0.0 to 401.0 Ohms; Beeps from 0.0 to 100.0 Ohms

## Specifications

### RTD and OHMS Source

Accuracy From 1 to 10.2 mA External Excitation Current	$\pm(0.025\% \text{ of Full Scale} + 0.075 \text{ Ohms})$
Below 1 mA of External Excitation Current	$\pm(0.025\% \text{ of Full Scale} + 0.075 \text{ Ohms} + \frac{0.025 \text{ mV}}{\text{mA Excitation Current}})$
Resistance Ranges	0.00 to 401.00, 0.0 to 4010.0 Ohms
Allowable Excitation Current Range	<401 Ohm: 10.2 mA max; steady or pulsed/intermittent 401 to 4000 Ohms: 1 mA max; steady or pulsed/intermittent
Pulsed Excitation Current Compatibility	DC to 0.01 second pulse width

### Frequency Source

Ranges	1 to 2000 CPM, 0.01 to 999.99 Hz, 0.1 to 9999.9 Hz, 0.001 to 20.000 kHz
Accuracy	$\pm (0.02 \% \text{ of Reading} + 0.01\% \text{ Full Scale})$
Output Waveform	Square Wave, Zero Crossing -1.0 to +5 V peak-to-peak $\pm 10\%$
Risetime (10 to 90% of amplitude)	< 10 microseconds
Output Impedance	< 1 Ohm
Source Current	> 1 mA rms at 20 kHz
Short Circuit Duration	Infinite
Optical Coupling	Green LED (HZ SYNC) flashes at output frequency

### Frequency Read

Ranges & Accuracy	Same as Frequency Source
Accuracy	$\pm (0.02 \% \text{ of Reading} + 0.01\% \text{ Full Scale})$
Trigger Level	1 V rms, dc coupled
Input Impedance	> 1 Meg Ohm + 60 pF

## Thermocouple Ranges & Accuracies

Table based on  $\leq \pm (0.02 \% \text{ of Reading} + 0.01 \text{ mV})$   
 Note: Doesn't include cold junction error of  $\pm 0.05^\circ\text{C}$

T/C Type	Degrees C Range	Accuracy °C	Degrees F Range	Accuracy °F	T/C Material	ISA/ANSI Color
<b>J</b>	-200.0 to -50.0	$\pm 0.5^\circ$	-328.0 to -58.0	$\pm 1.0^\circ$	+Iron -Constantan Jacket	White Red Black
	-50.0 to 300.0	$\pm 0.2^\circ$	-58.0 to 572.0	$\pm 0.4^\circ$		
	300.0 to 900.0	$\pm 0.3^\circ$	572.0 to 1652.0	$\pm 0.6^\circ$		
	900.0 to 1200.0	$\pm 0.4^\circ$	1652.0 to 2192.0	$\pm 0.8^\circ$		
<b>K</b>	-230.0 to -50.0	$\pm 1.2^\circ$	-382.0 to -58.0	$\pm 2.2^\circ$	+Chromel® -Alumel® Jacket	Yellow Red Yellow
	-50.0 to 550.0	$\pm 0.3^\circ$	-58.0 to 1022.0	$\pm 0.6^\circ$		
	550.0 to 1000.0	$\pm 0.5^\circ$	1022.0 to 1832.0	$\pm 0.8^\circ$		
	1000.0 to 1371.1	$\pm 0.6^\circ$	1832.0 to 2500.0	$\pm 1.1^\circ$		
<b>T</b>	-260.0 to -230.0	$\pm 2.9^\circ$	-436.0 to -382.0	$\pm 5.2^\circ$	+Copper -Constantan Jacket	Blue Red Blue
	-230.0 to -210.0	$\pm 1.0^\circ$	-382.0 to -346.0	$\pm 1.9^\circ$		
	-210.0 to -50.0	$\pm 0.8^\circ$	-346.0 to -58.0	$\pm 1.4^\circ$		
	-58.0 to 50.0	$\pm 0.3^\circ$	-58.0 to 122.0	$\pm 0.6^\circ$		
	50.0 to 400.0	$\pm 0.2^\circ$	122.0 to 752.0	$\pm 0.4^\circ$		
<b>E</b>	-240.0 to -200.0	$\pm 0.9^\circ$	-400.0 to -328.0	$\pm 1.7^\circ$	+Chromel -Constantan Jacket	Purple Red Purple
	-200.0 to 0.0	$\pm 0.5^\circ$	-328.0 to 32.0	$\pm 0.8^\circ$		
	0.0 to 350.0	$\pm 0.2^\circ$	32.0 to 662.0	$\pm 0.3^\circ$		
	350.0 to 1000.0	$\pm 0.3^\circ$	662.0 to 1832.0	$\pm 0.6^\circ$		
<b>R</b>	-18.3 to 100.0	$\pm 2.1^\circ$	-1.0 to 212.0	$\pm 3.8^\circ$	+Pt/13Rh -Platinum Jacket	Black Red Green
	100.0 to 500.0	$\pm 1.3^\circ$	212.0 to 932.0	$\pm 2.4^\circ$		
	500.0 to 1400.0	$\pm 1.0^\circ$	932.0 to 2552.0	$\pm 1.8^\circ$		
	1400.0 to 1767.8	$\pm 1.2^\circ$	2552.0 to 3214.0	$\pm 2.0^\circ$		
<b>S</b>	-18.3 to 100.0	$\pm 2.0^\circ$	-1.0 to 212.0	$\pm 3.7^\circ$	+Pt/10Rh -Platinum Jacket	Black Red Green
	100.0 to 350.0	$\pm 1.4^\circ$	212.0 to 662.0	$\pm 2.5^\circ$		
	350.0 to 1600.0	$\pm 1.1^\circ$	662.0 to 2912.0	$\pm 2.0^\circ$		
	1600.0 to 1767.8	$\pm 1.3^\circ$	2912.0 to 3214.0	$\pm 2.4^\circ$		
<b>B</b>	315.6 to 600.0	$\pm 3.2^\circ$	600.0 to 1122.0	$\pm 5.7^\circ$	+Pt/30Rh -Pt/6Rh Jacket	Grey Red Grey
	600.0 to 850.0	$\pm 1.7^\circ$	1122.0 to 1562.0	$\pm 3.1^\circ$		
	850.0 to 1100.0	$\pm 1.3^\circ$	1562.0 to 2012.0	$\pm 2.4^\circ$		
	1100.0 to 1820.0	$\pm 1.1^\circ$	2012.0 to 3308.0	$\pm 2.0^\circ$		

**Practical Instrument Electronics**

Tel: 585.872.9350 • Fax: 585.872.2638 • sales@piecal.com • www.piecal.com

## Thermocouple Ranges & Accuracies

Table based on  $\leq \pm (0.02 \% \text{ of Reading} + 0.01 \text{ mV})$

*Note: Doesn't include cold junction error of  $\pm 0.05^\circ\text{C}$*

T/C Type	Degrees C Range	Accuracy °C	Degrees F Range	Accuracy °F	T/C Material	ISA/ANSI Color
N	-230.0 to -150.0	$\pm 1.9^\circ$	-382.0 to -238.0	$\pm 3.4^\circ$	+Nicrosil -Nisil Jacket	Orange Red Orange
	-150.0 to -50.0	$\pm 0.7^\circ$	-238.0 to -58.0	$\pm 1.2^\circ$		
	-50.0 to 950.0	$\pm 0.4^\circ$	-58.0 to 1742.0	$\pm 0.8^\circ$		
	950.0 to 1300.0	$\pm 0.5^\circ$	1742.0 to 2372.0	$\pm 1.0^\circ$		
G (W)	100.0 to 350.0	$\pm 1.7^\circ$	212.0 to 662.0	$\pm 3.0^\circ$	+Tungsten -W26/Re Jacket	White Red White/Blue
	350.0 to 1700.0	$\pm 0.8^\circ$	662.0 to 3092.0	$\pm 1.5^\circ$		
	1700.0 to 2000.0	$\pm 1.0^\circ$	3092.0 to 3632.0	$\pm 1.8^\circ$		
	2000.0 to 2320.0	$\pm 1.1^\circ$	3632.0 to 4208.0	$\pm 2.1^\circ$		
C (W5)	-1.1 to 100.0	$\pm 0.8^\circ$	30.1 to 212.0	$\pm 1.4^\circ$	+W5/Re -W26/Re Jacket	White Red White/Red
	100.0 to 1000.0	$\pm 0.7^\circ$	212.0 to 1832.0	$\pm 1.3^\circ$		
	1000.0 to 1750.0	$\pm 1.2^\circ$	1832.0 to 3182.0	$\pm 2.1^\circ$		
	1750.0 to 2320.0	$\pm 2.0^\circ$	3182.0 to 4208.0	$\pm 3.5^\circ$		
D (W3)	-1.1 to 150.0	$\pm 1.0^\circ$	30.1 to 302.0	$\pm 1.8^\circ$	+W3/Re -W25/Re Jacket	White Red White/Yellow
	150.0 to 1100.0	$\pm 0.7^\circ$	302.0 to 2012.0	$\pm 1.3^\circ$		
	1100.0 to 1750.0	$\pm 1.0^\circ$	2012.0 to 3182.0	$\pm 1.8^\circ$		
	1750.0 to 2320.0	$\pm 2.0^\circ$	3182.0 to 4208.0	$\pm 3.6^\circ$		
P Platinel®	0.0 to 600.0	$\pm 0.3^\circ$	32.0 to 1112.0	$\pm 0.6^\circ$	+Pd55/Pt31/Au14 -Au65/Pd35 Jacket	Yellow Red Black
	600.0 to 900.0	$\pm 0.4^\circ$	1112.0 to 1652.0	$\pm 0.8^\circ$		
	900.0 to 1200.0	$\pm 0.6^\circ$	1652.0 to 2192.0	$\pm 1.1^\circ$		
	1200.0 to 1395.0	$\pm 0.7^\circ$	2192.0 to 2543.0	$\pm 1.2^\circ$		
DIN Colors						
L J-DIN	-200.0 to -50.0	$\pm 0.4^\circ$	-328.0 to -58.0	$\pm 0.7^\circ$	+Iron -Connstantan Jacket	Red Blue Blue
	-50.0 to 300.0	$\pm 0.2^\circ$	-58.0 to 572.0	$\pm 0.4^\circ$		
	300.0 to 900.0	$\pm 0.3^\circ$	572.0 to 1652.0	$\pm 0.5^\circ$		
U T-DIN	-200.0 to -50.0	$\pm 0.6^\circ$	-328.0 to -58.0	$\pm 1.1^\circ$	+Copper -Constantan Jacket	Red Brown Brown
	-50.0 to 50.0	$\pm 0.3^\circ$	-58.0 to 122.0	$\pm 0.5^\circ$		
	50.0 to 550.0	$\pm 0.2^\circ$	122.0 to 1022.0	$\pm 0.4^\circ$		
	550.0 to 600.0	$\pm 0.3^\circ$	1022.0 to 1112.0	$\pm 0.5^\circ$		

Practical Instrument Electronics

Tel: 585.872.9350 • Fax: 585.872.2638 • sales@piecal.com • www.piecal.com



## RTD Ranges & Accuracies

RTD Accuracy Based on  $\pm(0.025\%$  of Reading in Ohms + 0.075 Ohms)

RTD Type	Degrees C Range	°C	Degrees F Range	°F
Pt 100 Ohm DIN/IEC/JIS 1989 1.3850 (ITS-90)	-200.0 to 0.0	$\pm 0.2^\circ$	-328.0 to 32.0	$\pm 0.4^\circ$
	0.0 to 340.0	$\pm 0.3^\circ$	248.0 to 644.0	$\pm 0.6^\circ$
	340.0 to 640.0	$\pm 0.4^\circ$	644.0 to 1184.0	$\pm 0.8^\circ$
	640.0 to 850.0	$\pm 0.5^\circ$	1184.0 to 1562.0	$\pm 1.0^\circ$
Pt 100 Ohm (Burns) 1.3902	-200.0 to 10.0	$\pm 0.2^\circ$	328.0 to 50.0	$\pm 0.4^\circ$
	10.0 to 350.0	$\pm 0.3^\circ$	50.0 to 662.0	$\pm 0.6^\circ$
	350.0 to 650.0	$\pm 0.4^\circ$	662.0 to 1202.0	$\pm 0.8^\circ$
	650.0 to 850.0	$\pm 0.5^\circ$	1202.0 to 1562.0	$\pm 0.9^\circ$
Pt 100 Ohm (Old JIS 1981) 1.3916	-200.0 to 20.0	$\pm 0.2^\circ$	-328.0 to 68.0	$\pm 0.4^\circ$
	20.0 to 360.0	$\pm 0.3^\circ$	68.0 to 680.0	$\pm 0.6^\circ$
	360.0 to 650.0	$\pm 0.4^\circ$	680.0 to 1202.0	$\pm 0.8^\circ$
	650.0 to 850.0	$\pm 0.5^\circ$	1202.0 to 1562.0	$\pm 0.9^\circ$
Pt 100 Ohm (US Lab) 1.3926	-200.0 to 20.0	$\pm 0.2^\circ$	-328.0 to 68.0	$\pm 0.4^\circ$
	20.0 to 360.0	$\pm 0.3^\circ$	68.0 to 680.0	$\pm 0.6^\circ$
	360.0 to 660.0	$\pm 0.4^\circ$	680.0 to 1220.0	$\pm 0.8^\circ$
	660.0 to 850.0	$\pm 0.5^\circ$	1220.0 to 1562.0	$\pm 0.9^\circ$
Pt 1000 Ohm DIN/IEC/JIS 1989 1.3850	-200.0 to 0.0	$\pm 0.2^\circ$	-328.0 to 32.0	$\pm 0.4^\circ$
	0.0 to 340.0	$\pm 0.3^\circ$	248.0 to 644.0	$\pm 0.6^\circ$
	340.0 to 640.0	$\pm 0.4^\circ$	644.0 to 1184.0	$\pm 0.8^\circ$
	640.0 to 850.0	$\pm 0.5^\circ$	1184.0 to 1562.0	$\pm 1.0^\circ$
Copper 10 Ohm 1.4274 (Minco)	-200.0 to 260.0	$\pm 2.0^\circ$	-328.0 to 500.0	$\pm 3.6^\circ$
Copper 50 Ohm 1.4280	-50.0 to 150.0	$\pm 0.4^\circ$	-58.0 to 302.0	$\pm 0.8^\circ$
Ni 120 Ohm 1.6720 (Pure)	-80.0 to 260.0	$\pm 0.1^\circ$	-112.0 to 500.0	$\pm 0.3^\circ$
Ni 110 Ohm (Bristol 7 NA) 1.5801	-100.0 to 260.0	$\pm 0.2^\circ$	-148.0 to 500.0	$\pm 0.4^\circ$

# Panel Cutout Dimensions

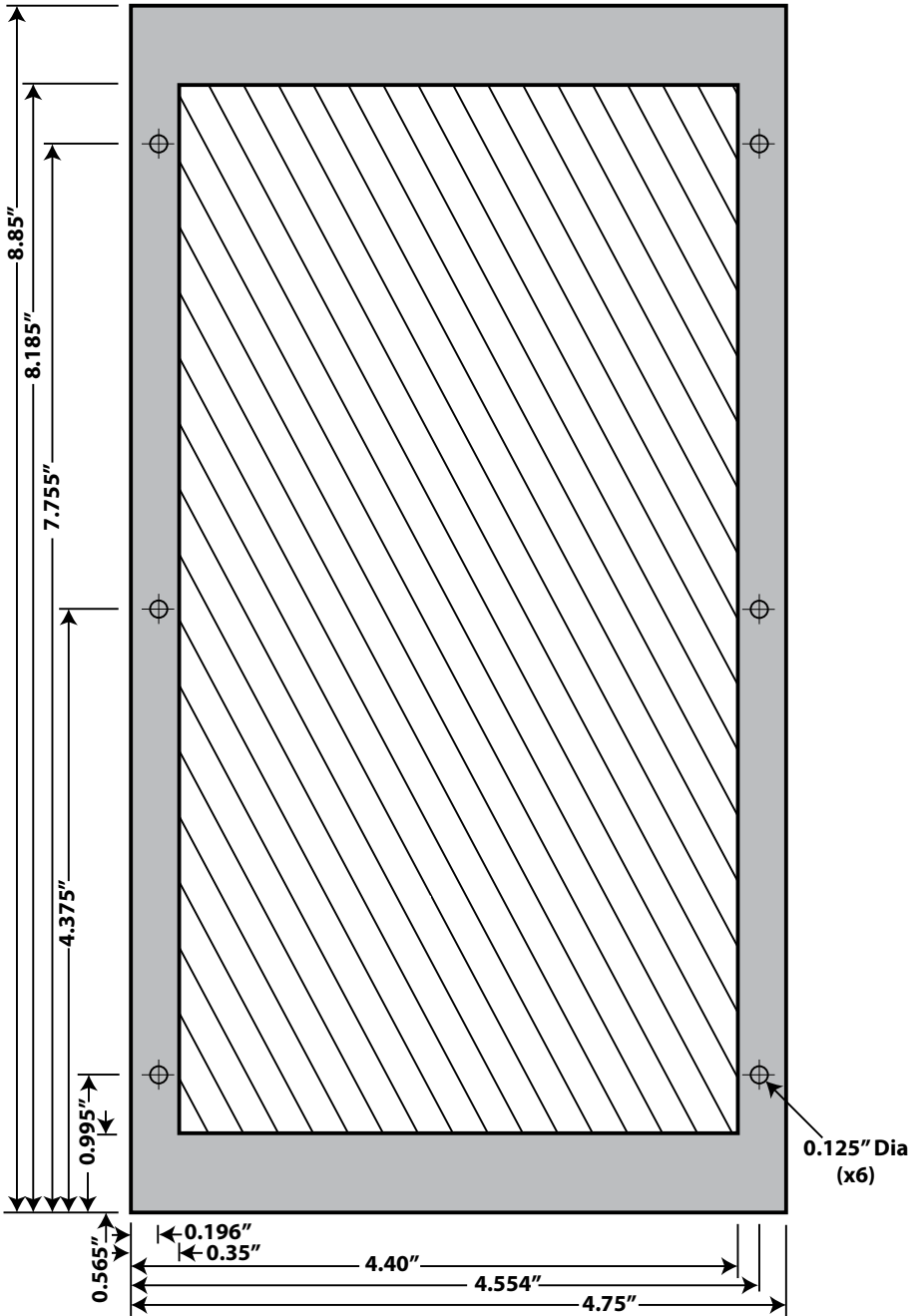

Practical Instrument Electronics

Tel: 585.872.9350 • Fax: 585.872.2638 • sales@piecal.com • www.piecal.com

# Mounted in Panel



Practical Instrument Electronics

Tel: 585.872.9350 • Fax: 585.872.2638 • sales@piecal.com • www.piecal.com

## Mounted in Panel



Rear view of 830PM mounted in a panel with AC Adapter