

P/N: 44401-0202

Copyright

© 2016, FLIR Systems, Inc.

All rights reserved worldwide. Names and marks appearing herein are either registered trademarks or trademarks of FLIR Systems and/or its subsidiaries. All other trademarks, trade names or company names referenced herein are used for identification only and are the property of their respective owners.

Document identity

Publ. No.: 44401-0202

Release:

Commit: 35207

Language: en-US

Modified: 2016-04-27

Formatted: 2016-04-27

Website

<http://www.flir.com>

Customer support

<http://support.flir.com>

Disclaimer

Specifications subject to change without further notice. Camera models and accessories subject to regional market considerations. License procedures may apply. Products described herein may be subject to US Export Regulations. Please refer to exportquestions@flir.com with any questions.



General description	
<p>The FLIR GF300 is an infrared camera for optical gas imaging (OGI) that visualizes and pinpoints leaks of methane and other volatile organic compounds (VOCs), without the need to shut down the operation. The portable camera also greatly improves operator safety, by detecting emissions at a safe distance, and helps to protect the environment by tracing leaks of environmentally harmful gases.</p> <p>The FLIR GF300 is used in industrial settings such as oil refineries, natural gas processing plants, offshore platforms, chemical/petrochemical industries, and biogas and power generation plants.</p>	
Benefits:	
<ul style="list-style-type: none"> Improved efficiency: The FLIR GF300 reduces revenue loss by pinpointing even small gas leaks quickly and efficiently, and from a distance. It also reduces the inspection time by allowing a broad area to be scanned rapidly and without the need to interrupt the industrial process. Increased worker safety: OGI allows gas leaks to be detected in a non-contact mode and from a safe distance. This reduces the risk of the user being exposed to invisible and potentially harmful or explosive chemicals. With a FLIR GF300 gas imaging camera it is easy to scan areas of interest that are difficult to reach with conventional methods. The camera is ergonomically designed, with a bright LCD and tiltable viewfinder, which facilitates its use over a full working day. Protecting the environment: Several VOCs are dangerous to human health or cause harm to the environment, and are usually governed by regulations. Even small leaks can be detected and documented using the FLIR GF300 camera. 	
<p>Detects the following gases: benzene, ethanol, ethylbenzene, heptane, hexane, isoprene, methanol, MEK, MIBK, octane, pentane, 1-pentene, toluene, xylene, butane, ethane, methane, propane, ethylene, propylene.</p>	
Licensing and classification	
License information	Interchangeable lens version of the FLIR GF3XX series requires US Department of State License and will be subject to limitations on resale, except inside US. Allow a minimum of 90 days after application submittal for approval.
Imaging and optical data	
IR resolution	320 × 240 pixels
Thermal sensitivity/NETD	<15 mK @ +30°C (+86°F)
Field of view (FOV)	24° × 18°
Minimum focus distance	0.3 m (1.0 ft.)
Focal length	23 mm (0.89 in.)
Lens identification	Automatic

P/N: 44401-0202

© 2016, FLIR Systems, Inc.

#44401-0202; r. /35207; en-US

Imaging and optical data	
F-number	1.5
Focus	Automatic (one touch) or manual (electric or on the lens)
Zoom	1–8x continuous, digital zoom
Digital image enhancement	Noise reduction filter, high sensitivity mode (HSM)

Detector data	
Detector type	Focal plane array (FPA), cooled InSb
Spectral range	3.2–3.4 μm
Detector pitch	30 μm
Sensor cooling	Stirling Microcooler (FLIR MC-3)
Detects following gases	Benzene, Ethanol, Ethylbenzene, Heptane, Hexane, Isoprene, Methanol, MEK, MIBK, Octane, Pentane, 1-Pentene, Toluene, Xylene, Butane, Ethane, Methane, Propane, Ethylene, Propylene

Electronics and data rate	
Full frame rate	60 Hz

Image presentation	
Display	Built-in widescreen, 4.3 in. LCD, 800 × 480 pixels
Viewfinder	Built-in, tiltable OLED, 800 × 480 pixels
Automatic image adjustment	Continuous/manual; linear or histogram based
Manual image adjustment	Level/span

Image presentation modes	
Image modes	IR image, visual image, high sensitivity mode (HSM)

Measurement	
Temperature range	–20°C to +350°C (–4°F to +662°F)

Set-up	
Menu commands	Level, span Auto adjust continuous/manual/semi-automatic Zoom Palette Start/stop recording Store image Playback/recall image
Color palettes	Iron, Gray, Rainbow, Arctic, Lava, Rainbow HC
Set-up commands	1 programmable button, overlay recording mode, local adaptation of units, language, date and time formats

Storage of images	
Storage media	Removable SD or SDHC memory card , two card slots
Image storage capacity	> 1200 images (JPEG) with post process capability per GB on memory card



FLIR GF300 24°

P/N: 44401-0202

© 2016, FLIR Systems, Inc.

#44401-0202; r. /35207; en-US

Storage of images	
Image storage mode	IR/visual images Visual image can automatically be associated with corresponding IR image
Periodic image storage	Every 10 seconds up to 24 hours
File formats	Standard JPEG, 14 bit measurement data included
Geographic Information System	
GPS	Location data automatically added to every image from built-in GPS
Video recording in camera	
Non-radiometric IR video recording	MPEG4 (up to 60 minutes/clip) to memory card. Visual image can automatically be associated with corresponding recording of non-radiometric IR video.
Visual video recording	MPEG4 (25 minutes/clip) to memory card
Video streaming	
Non-radiometric IR video streaming	RTP/MPEG4
Digital camera	
Built-in digital camera	3.2 Mpixels, auto focus, and two video lamps
Laser pointer	
Laser	Activated by dedicated button
Laser classification	Class 2
Laser type	Semiconductor AlGaInP diode laser, 1 mW, 635 nm (red)
USB	
USB	<ul style="list-style-type: none"> • USB-A: Connect external USB device • USB Mini-B: Data transfer to and from PC
USB, standard	USB Mini-B: 2.0 high speed
Composite video	
Video out	Digital video output (image)
Power system	
Battery type	Rechargeable Li ion battery
Battery voltage	7.2 V
Battery capacity	4.4 Ah
Battery operating time	> 3 hours at 25°C (+68°F) and typical use
Charging system	In camera (AC adapter or 12 V from a vehicle) or 2-bay charger
Charging time	2.5 h to 95% capacity, charging status indicated by LED's
External power operation	AC adapter 90–260 VAC, 50/60 Hz or 12 V from a vehicle (cable with standard plug, optional)
DC operation	10.8 to 16 V DC, polarity protected (proprietary protected)
Power	8.5 W typically
Start-up time	Typically 7 min. @ 25°C (+77°F)



FLIR GF300 24°

P/N: 44401-0202

© 2016, FLIR Systems, Inc.

#44401-0202; r. /35207; en-US

Environmental data	
Operating temperature range	-20°C to +50°C (-4°F to +122°F)
Storage temperature range	-30°C to +60°C (-22°F to +140°F)
Humidity (operating and storage)	IEC 68-2-30/24 h 95% relative humidity +25°C to +40°C (+77°F to +104°F) (2 cycles)
Directives	<ul style="list-style-type: none"> • 73/23EEC • 2004/108/EC • 2002/95/EC • 2002/96/EC
EMC	<ul style="list-style-type: none"> • EN61000-6-4 (Emission) • EN61000-6-2 (Immunity) • FCC 47 CFR Part 15 class A (Emission) • EN 61 000-4-8, L5
Encapsulation	IP 54 (IEC 60529)
Shock	25 g (IEC 60068-2-27)
Vibration	2 g (IEC 60068-2-6)
Safety	Power supply: EN/UL/IEC 60950-1

Physical data	
Camera weight, excl. lens and battery	1.94 kg (4.27 lb.)
Camera weight, incl. lens and excl. battery	2.24 kg (4.94 lb.)
Camera weight, incl. lens and battery	2.48 kg (5.47 lb.)
Battery weight	0.24 kg (0.52 lb.)
Camera size, excl. lens (L x W x H)	284 x 169 x 161 mm (11.2 x 6.7 x 6.3 in.)
Cameras size, incl. lens (L x W x H)	306 x 169 x 161 mm (12.0 x 6.7 x 6.3 in.)
Battery size (L x W x H)	141 x 47 x 28 mm (5.5 x 1.8 x 1.1 in.)
Battery charger size (L x W x H)	158 x 122 x 25 mm (6.2 x 4.8 x 1.0 in.)
Tripod mounting	UNC ¼"-20
Housing material	Aluminum, magnesium
Grip material	TPE thermoplastic elastomers

Shipping information	
Packaging, type	Cardboard box
List of contents	<ul style="list-style-type: none"> • Infrared camera with lens • Battery charger • Battery, 2 ea. • FLIR VideoReport PC software CD-ROM • Hard transport case • HDMI-DVI cable • HDMI-HDMI cable • Lens cap (2 ea.) • Lens cap (mounted on lens) • Memory card • Power supply, incl. multi-plugs • Printed documentation • Shoulder strap • USB cable
Packaging, weight	
Packaging, size	400 x 190 x 510 mm (15.7 x 7.5 x 20.1 in.)
EAN-13	7332558002728
UPC-12	845188001988
Country of origin	Sweden



FLIR GF300 24°

P/N: 44401-0202

© 2016, FLIR Systems, Inc.

#44401-0202; r. /35207; en-US

Supplies & accessories:

- T197387; IR lens, 24° with case for GF300, GF309, GF320
- T197388; IR lens, 6° with case for GF300, GF309, GF320, GF346.
- T197385; IR lens, 14.5° with case for GF300, GF309, GF320
- T197692; Battery charger, incl. power supply with multi plugs
- T910814; Power supply, incl. multi plugs
- T198511; Li-Ion Battery pack 7.4V 33Wh
- T911230ACC; Memory card SDHC 4 GB
- 1910423; USB cable Std A <-> Mini-B
- T198509; Cigarette lighter adapter kit, 12 VDC, 1.2 m/3.9 ft.
- T910815ACC; HDMI to HDMI cable 1.5 m
- T910816ACC; HDMI to DVI cable 1.5 m
- T197555; Hard transport case for FLIR GF3xx-Series
- T198585; FLIR VideoReport
- DSW-10000; FLIR IR Camera Player
- T199233; FLIR Atlas SDK for .NET
- T199234; FLIR Atlas SDK for MATLAB
- T198567; ThermoVision™ System Developers Kit Ver. 2.6
- T198566; ThermoVision™ LabVIEW® Digital Toolkit Ver. 3.3

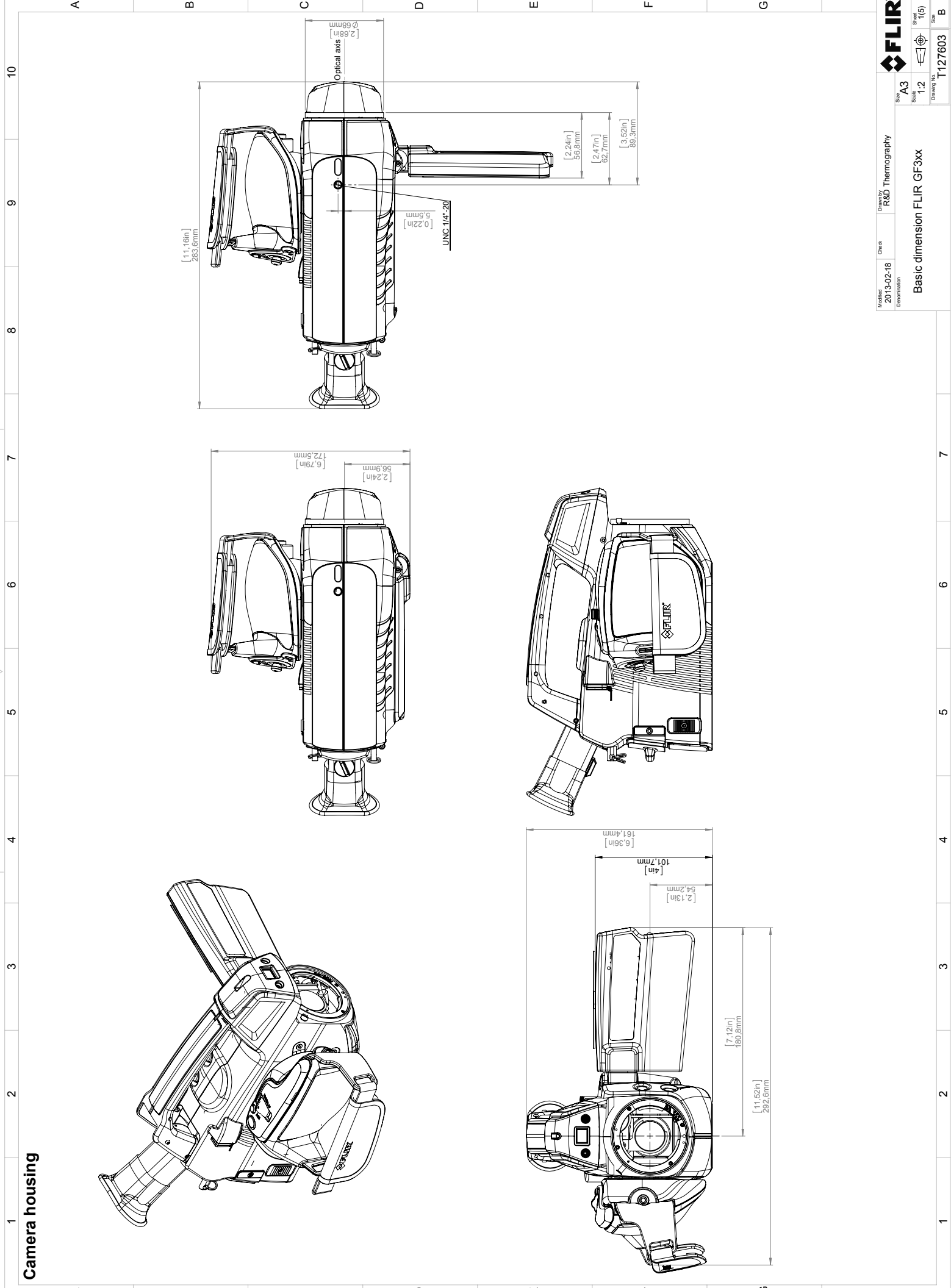

©2012 FLIR Systems, Inc. All rights reserved worldwide. No part of this drawing may be reproduced, stored in a retrieval system, or transmitted in any form, or by any means, electronic, mechanical, photocopying, recording, or otherwise, without written permission from FLIR Systems, Inc. Specifications subject to change without further notice. Dimensional data is based on nominal values. Products may be subject to regional market considerations. License procedures may apply. Product may be subject to US Export Regulations. Please refer to exportquestions@flir.com with any questions. Division contrary to US law is prohibited.

FLIR

Size: **A3**

Scale: **1:2**

Sheet: **1(5)**

Drawing No.: **1127603**

Modified: **2013-02-18**

Check: **Drawn By: R&D Thermography**

Denomination: **Basic dimension FLIR GF3xx**

**Camera with Lens IR f=23 mm (24°)
Camera with Lens IR f=38 mm (14,5°)**

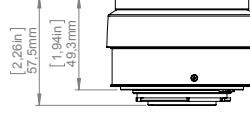
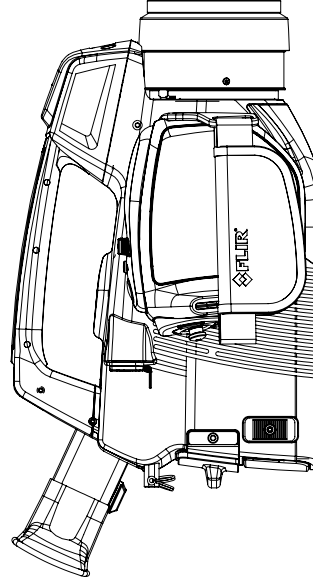
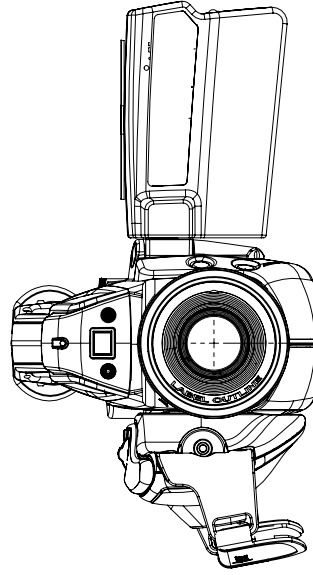
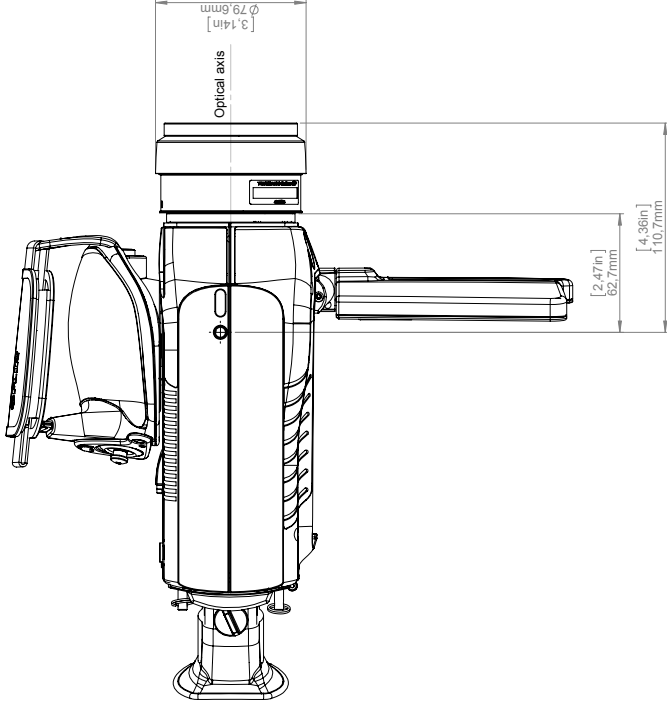

For additional dimensions see page 1

Modified	Drawn by	Size	
2013-02-18	R&D Thermography	A3	
Check	Drawn by	Scale	
	R&D Thermography	1:2	
Denotation		Drawing No.	Size
			B

Basic dimension FLIR GF3xx

1127603

Camera with Lens IR f=92 mm (6°)

