

2820

Superior Performance

- 400MHz to 6GHz frequency range
- -146dBm to +35dBm measurement range
- 40MHz signal bandwidth
- ±0.6dB absolute amplitude accuracy
- ±0.15dB amplitude repeatability

High Speed

- 650MHz/s @1kHz bandwidth characteristic spectrum analysis sweep update rate
- 24ms characteristic signal analysis time for GSM measurement set
- 30ms characteristic signal analysis personality switching time

Flexible

- MIMO-ready capability for WLAN and WiMAX
- Multi-purpose measurements: Spectrum Analysis, Adjacent Channel Power Ratio, Channel Power List, Zero Span
- Signal analysis options: GSM, EDGE, W-CDMA, cdmaOne, cdma2000, WLAN, WiMAX
- Output I-Q data to a PC for analysis
- Advanced PC connectivity: GPIB, USB, LAN, and LXI Class C

APPLICATIONS

- R&D and production testing of:
 - Wireless equipment
 - Modules and sub-assemblies
 - RFIC devices
- Signal monitoring
- Education

RF Vector Signal Analyzer

400MHz to 4GHz or 6GHz



The Model 2820 RF Vector Signal Analyzer is a mid-performance test instrument designed for R&D and production testing of modern RF communications equipment and devices. This next-generation instrument combines state-of-the-art RF and digital signal processing (DSP) technology to measure RF test signals rapidly with high accuracy and excellent repeatability. Its compact half-rack enclosure and competitive pricing make it a cost-effective solution for many test applications. The Model 2820's DSP-based software-defined radio (SDR) architecture and 40MHz bandwidth ensure it has the capability to measure today's signals and also the flexibility to handle tomorrow's. Today's mobile phones are designed to connect to more types of devices than ever before, so they must integrate with a growing number of wireless standards. As new wireless standards emerge, the Model 2820 is engineered for easy upgrades, which extend its useful life and provide an ongoing return on investment far longer than traditional instruments.

The Model 2820's Windows CE® operating system and intuitive graphical user interface allow users their choice of operating it via the touch-screen user interface, the front panel controls, or with a mouse. GPIB, USB, and 100Base-T Ethernet LAN ports offer a variety of options for connecting to a PC; it is LXI Class C compliant, so it's equally easy to connect to an internal network or the Internet. Tests can be created by developing scripts using SCPI (Standard Commands for Programmable Instrumentation) commands, with IVI-COM or IVI-C drivers, or by assembling LabVIEW® building blocks.



A built-in LXI webpage interface allows monitoring and controlling the Model 2820 from any Internet connection anywhere in the world.

2820

Ordering Information

2820 RF Vector Signal Analyzer

Configuration Choices (Specify one from each group in the format 2820-xx-yy-zzz)

Example: 2820-FP-BT-006

RF Connector Location (-xx):

-FP Front-panel RF input
-RP Rear-panel RF input

Use Configuration (-yy)

-BT Bench-top
-RK Rack-mount

Frequency Range (-zzz):

-004 400MHz to 4GHz
-006 400MHz to 6GHz

Options

2820-CDMA-R

cdma2000 and IS-95A reverse-link signal analysis personality

2820-GSM

GSM, GPRS, and EDGE signal analysis personality

2820-WCDMA-D

W-CDMA FDD downlink signal analysis personality

2820-WCDMA-U

W-CDMA FDD uplink signal analysis personality

2820-80211

WLAN 802.11a, b, g, j, and n-SISO signal analysis personality

Optional Software

280111 WLAN 802.11n MIMO signal analysis software

Accessories Supplied

AC power cable

Printed Quick Start Guide

CD-ROM containing 2820 VSA System Help, utility programs, and PDF files (also available on-line at www.keithley.com)

On-board help system

SERVICES AVAILABLE

2820-3Y-EW	1-year factory warranty extended to 3 years from date of shipment
C/2820-3Y-DATA	3 (Z540-1 compliant) calibrations within 3 years of purchase*

* Not available in all countries

1.888.KEITHLEY (U.S. only)

www.keithley.com

RF Vector Signal Analyzer

400MHz to 4GHz or 6GHz

Innovative Architecture

The Model 2820's software-defined radio architecture allows it to analyze and demodulate virtually any signal up to 40MHz bandwidth without needing to upgrade hardware. This provides high flexibility in R&D and production environments and reduces capital equipment cost. Unlike traditional instrument architectures, this DSP-based SDR architecture combines the ability to measure the signals produced by current devices with the adaptability to handle signals future devices will produce, so the instrument remains productive over a longer period.

When an RF signal is input to the Model 2820, it's down-converted to an intermediate frequency (IF), digitized by a fast, high resolution analog-to-digital converter (ADC), and routed into the waveform memory. The high speed DSP analyzes and demodulates the signal waveform. That means the instrument's RF signal analysis capability is defined through DSP software rather than in hardware. The DSP can switch rapidly between various optional signal analysis personalities. Alternatively, the signal's I-Q data pairs can be output to an external PC for analysis.

A 100MHz fixed-rate ADC and a fixed-bandwidth, brick-wall, anti-alias filter combine to ensure high signal integrity by reducing alias spurs. The Digital Up/Down Converter (DUC/DDC) compresses and decompresses waveforms, which allows multiple signal sampling rates, conserves waveform memory space, and speeds signal processing. The instrument's Field-Programmable Gate Array (FPGA) supports fast triggering and high speed signal conditioning and routing.

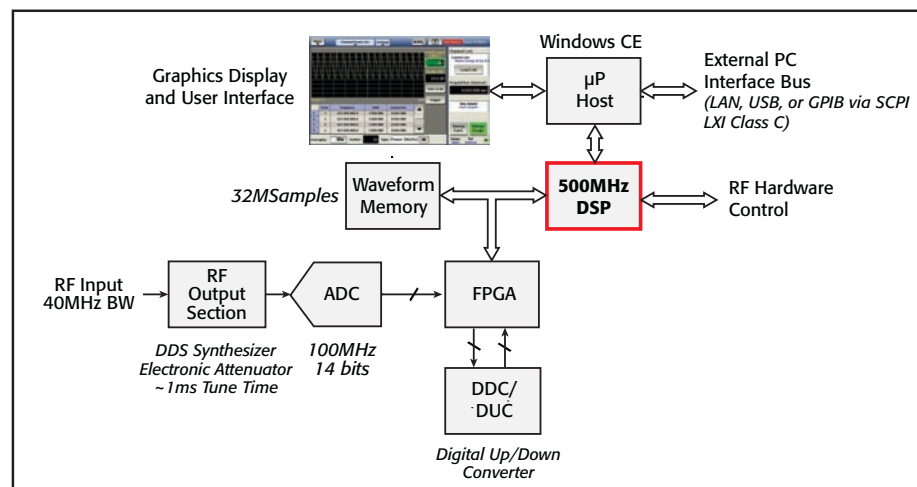

The key components of the Model 2820's DSP-based software-defined radio architecture are optimized for high accuracy and speed while reducing instrument cost and size.

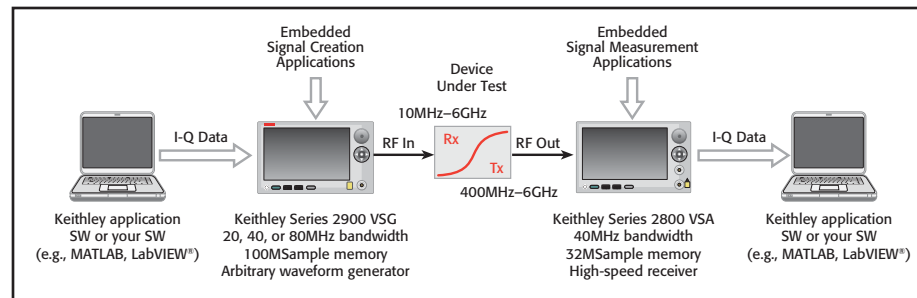

Keithley's Series 2800 RF Vector Signal Analyzers and Series 2900 RF Vector Signal Generators are engineered for operating versatility. Use built-in application personalities and download results, or upload and download I-Q waveform data from a connected PC.

Discover the Flexibility of Three Powerful Operating Modes

- Spectrum Analyzer Mode**—The Model 2820 has four multi-purpose spectrum analysis functions for measuring the most common signal parameters of RF signals.
 - The *Spectrum Analysis function* displays the RF power vs. frequency of all signals within a user-defined frequency span. A wide selection of resolution bandwidths and filter types are available to analyze the signal's spectral characteristics. Traditional markers and marker functions are used to measure the RF signal's parameters.
 - The *ACPR (Adjacent Channel Power Ratio) function* measures the channel power of the primary signal along with that of adjacent channels and next-adjacent channels. The channel frequency, channel bandwidth, test limits, and adjacent channels are user-definable. Each channel frequency is measured separately for high accuracy. When it's desirable to reduce test times, users can also choose not to measure the adjacent and next-adjacent channels.
 - The *Channel Power List function* allows setting up a pre-defined list of frequencies, measurement bandwidths, and measurement times. Triggering is commonly used to synchronize the list with other instruments in a system.
 - Using the *Zero Span function*, the analyzer becomes a fixed-tuned receiver to capture and analyze signals up to 40MHz bandwidth at a fixed carrier frequency. An RF signal is demodulated and the signal power vs. time is displayed. A wide selection of bandwidths and filter types are available and an assortment of triggers can be used to capture the signal easily.

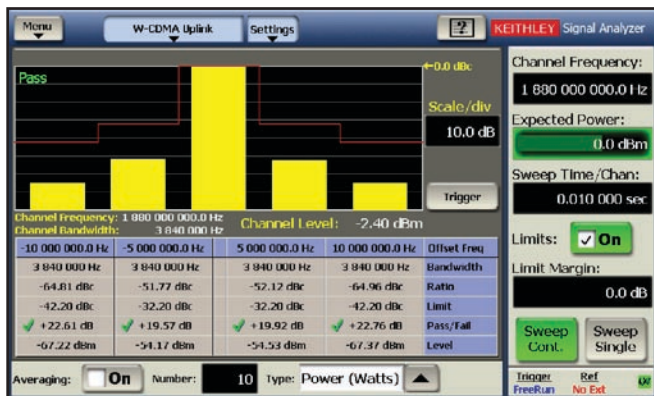

Use the Adjacent Channel Power Ratio function to define the test parameters and the test limits for non-standards-based signals.

- Vector Signal Analysis Mode**—The Model 2820 is designed to be combined with a variety of signal analysis personality options for testing to the most common wireless standards, such as GSM, EDGE, W-CDMA FDD, cdmaOne, cdma2000, 802.11 WLAN, and 802.16e mobile-WiMAX. A robust set of measurements, instrument settings, and test limits are customized for each of the various standards, saving instrument configuration time and minimizing the potential for operator error. For example, an ACPR measurement for each of the standards is part of the signal analysis personality option.



Measure the key parameters of GSM and EDGE signals quickly and easily with the Model 2820-GSM option. The GSM time mask is shown here, along with the results of the signal measurement.

- Signal Capture Capability** – The Model 2820 can receive RF signals of up to 40MHz bandwidth and store them in its 32 megasample waveform memory as I-Q data pairs. A waveform record size of up to 30 seconds can be captured at a one megasample/second sampling rate. The I-Q data can be uploaded to a PC through the GPIB, USB, or LAN interfaces for analysis or to playback with an RF vector signal generator. The signal waveform can be analyzed with PC-based software such as MATLAB, LabVIEW, or a variety of software applications from Keithley.

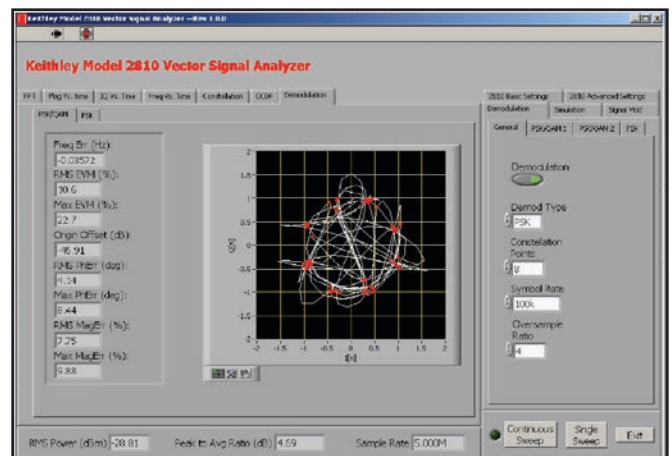

It's easy to upload I-Q signal data pairs from the Model 2820 to a PC for analysis. The free Vector Signal Analyzer software application shown here can be downloaded from www.keithley.com.

2820

RF Vector Signal Analyzer

400MHz to 4GHz or 6GHz

High Accuracy and Repeatability

The Model 2820's RF input circuitry was designed to combine simplicity with high accuracy and repeatable performance. In R&D applications, this helps engineers determine design stability and performance consistency. In production test, high measurement accuracy and repeatability provide confidence in the quality of the devices tested. It also allows minimizing measurement guard bands, which helps increase product yields. Significant signal analysis performance specifications include:

- Absolute amplitude accuracy of $\pm 0.6\text{dB}$ (typically $\pm 0.2\text{dB}$) with a 0dBm signal up to 2GHz
- $\pm 0.2\text{dB}$ relative amplitude accuracy (display fidelity)
- $\pm 0.15\text{dB}$ (typically $\pm 0.07\text{dB}$) amplitude repeatability

The instrument's absolute amplitude accuracy can be increased by using an external power meter to correct for frequency response variations of the analyzer and test system cables connected to the DUT test fixture interface. A power correction table feature in the Model 2820 allows users to enter amplitude offset values vs. frequency to correct all power value readings. This simplifies test system calibration and reduces operator errors.

Ultra-fast Measurements

The Model 2820 was designed to make fast measurements without compromising accuracy. Its high speed DSP controls the instrument hardware and runs all measurement operations. For example, when using the traditional spectrum analysis function, the instrument can sweep 650MHz/s in a 1kHz bandwidth, which is more than 800 times faster than traditional spectrum analyzers. And, because the Model 2820 has an all-digital IF architecture, it maintains its high speed over a wide range of resolution bandwidths and frequency spans. For example, in R&D product verification testing, this can reduce the time required for spur searching measurements from several weeks to a few days, significantly reducing time to market.

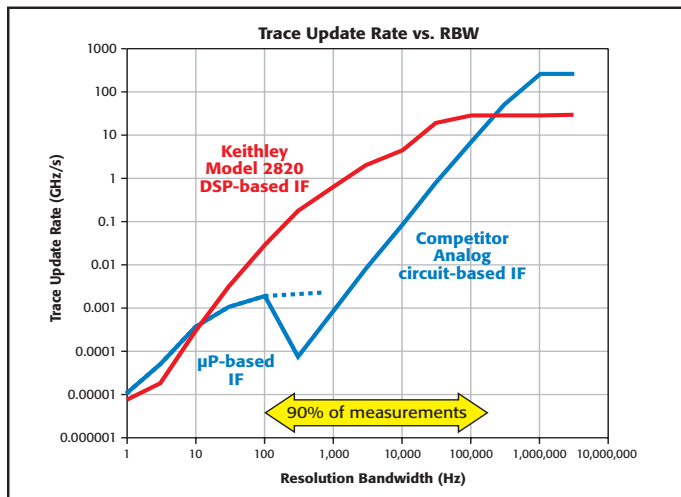

The Model 2820's DSP-based architecture allows it to provide unprecedented measurement speeds. This graph shows that the spectrum analysis measurement speed (measured in GHz frequency span per second) of the Model 2820's DSP-based IF is up to 800 times faster than a typical competitive spectrum analyzer which uses both microprocessor-based and traditional analog IF technologies.

The Model 2820's RF circuitry was optimized for speed and accuracy. The RF input section employs a patent-pending DDS (Direct Digital Synthesis) synthesizer design to switch frequencies in 1.3ms using List or Sweep modes and in 3ms using a remote SCPI command.

An electronic attenuator is used to change the Reference Level to measure rapidly over a wide dynamic range. This hardware approach has the added benefit of superior measurement repeatability over millions of cycles in production environments, unlike relatively slow mechanical attenuators, which gradually degrade after a few thousand cycles. Flexible trigger and synchronization choices further enhance measurement speed.

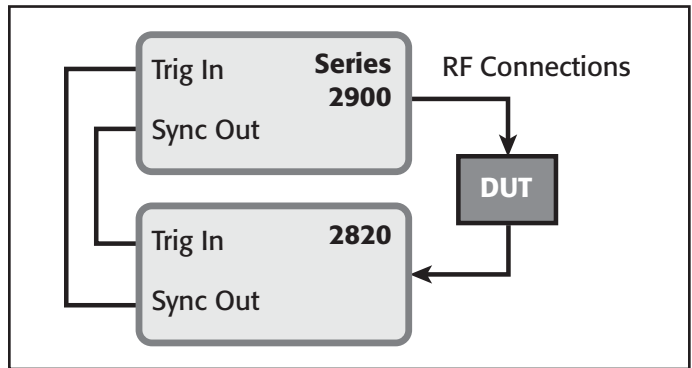

The Model 2820's trigger input and sync output connections simplify synchronizing its operation with that of other test instruments, such as Keithley Series 2900 RF Signal Generators, in high speed measurement applications.

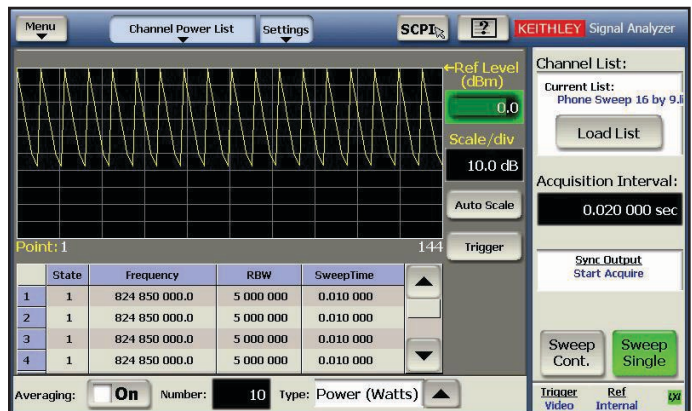

The Model 2820's Channel Power List mode supports measuring power at multiple frequencies rapidly and flexibly.

The Model 2820 captures signal data and stores it in its waveform memory, allowing the DSP to make measurements on one common set of data. Only measurement results are passed to the host microprocessor and to the PC, which ensures dramatically better measurement speed and greater consistency of measurement results when compared with measurements made with instruments using microprocessor-based architectures. For example, six signal measurements can be completed on a GSM signal in 24ms and seven measurements can be completed on a W-CDMA signal in 60ms. Switching between measurement types takes from 8ms to 29ms.

1.888.KEITHLEY (U.S. only)

www.keithley.com

KEITHLEY

2820

RF Vector Signal Analyzer 400MHz to 4GHz or 6GHz

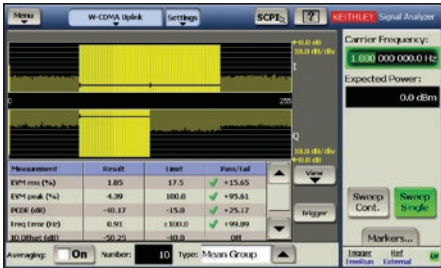

Complete a set of seven signal measurements in about 60ms using a Model 2920 equipped with the optional 2900-WCDMA-U, the W-CDMA FDD Uplink Signal Analysis personality.

Optimized for High Speed Production Test

Keithley's instruments can be configured into sophisticated test systems that dramatically reduce device test times and lower capital costs compared to traditional rack-and-stack test systems. They are designed for demanding system applications requiring ultra-fast test times and accurate, repeatable measurements. Test script control and intra-instrument triggering work in cooperation to minimize bus traffic from the PC controller. Keithley's RF test systems have reduced test times by up to 70% in RFIC production applications. Using smart instruments instead of test modules also reduces the engineering time for system test integration. This lowers schedule risk and provides greater flexibility to reconfigure the system quickly to transition new devices and equipment into production.

MIMO Test Systems

Every Model 2820 is MIMO-ready to meet the requirements of the 802.11n WiFi and 802.16e mobile-WiMAX Wave 2 multi-input, multi-output communications standards. Standard Model 2820 instruments can be configured into a $\times 2$, $\times 3$, or $\times 4$ multi-input test system with the addition of a Model 2895 MIMO Synchronization Unit. The synchronization unit distributes a common LO (local oscillator), common clock, and precise trigger to all the signal analyzers connected in the system. This results in a high performance multi-input signal analysis test system with precise synchronization and low jitter between each of the signal analyzer inputs of both the RF carriers and waveform signal samplers.

Full 4×4 MIMO testing is possible when this configuration is combined with the Model 2920-based multi-output signal generator test

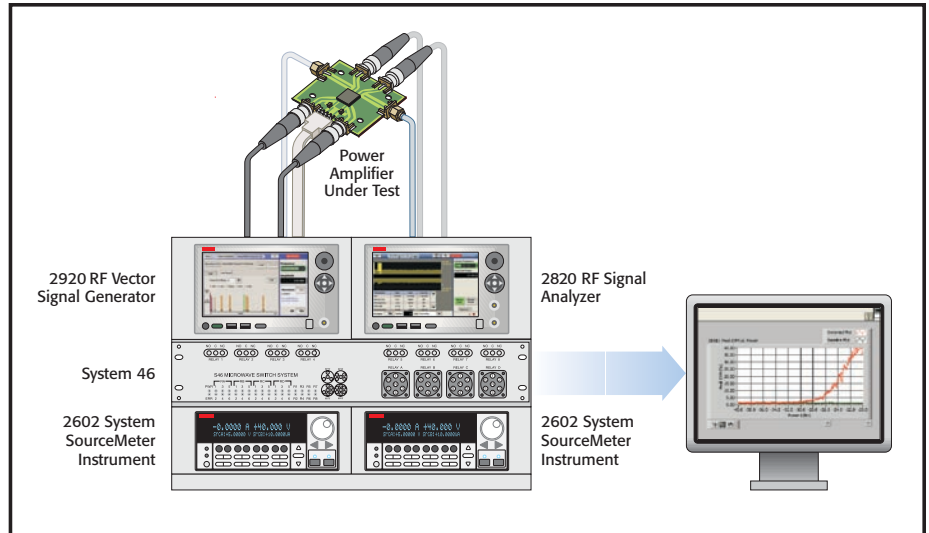

Through the use of test script control and intra-instrument triggering, this RF power amplifier test system based on the Model 2820 and the Model 2920 can reduce test times by up to 70%.

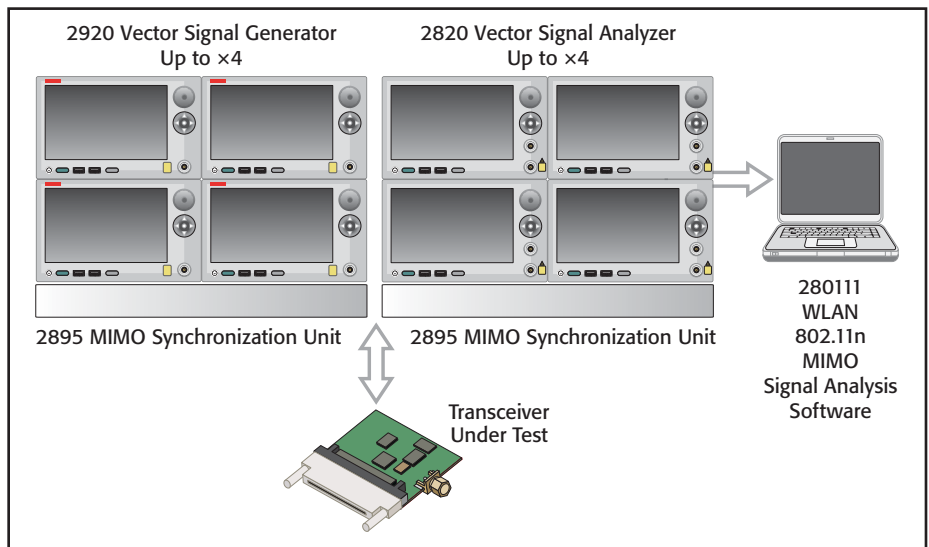

This 4×4 MIMO test system ensures precise synchronization and low jitter when testing WiFi, WiMAX, and other MIMO devices and equipment.

system. Imagine configuring a MIMO test system initially as a 2×2 system, then later upgrading it to 3×3 or to 4×4 by adding more Model 2820 and 2920 units. Moreover, the instruments need not be dedicated to a MIMO system. They can be configured for use either in a MIMO system or as stand-alone SISO (single input, single output) instruments by selecting the configuration in firmware and changing a few cables on the rear panel.

1.888.KEITHLEY (U.S. only)

www.keithley.com

KEITHLEY

Signal analyzer for RF communications testing

RF/MICROWAVE

2820

RF Vector Signal Analyzer

400MHz to 4GHz or 6GHz

802.11n MIMO Signal Analysis Software

Model 280111 WLAN 802.11n MIMO Signal Analysis software is an industry-leading multi-channel signal analysis solution for up to four OFDM (Orthogonal Frequency Division Multiplexing) channels. It includes an extensive measurement set with a fast, easy-to-configure GUI and a SCPI command set for interfacing with test systems. It's designed to stream data from up to four Model 2920s into the PC, analyze all of the received signals, and display the results.

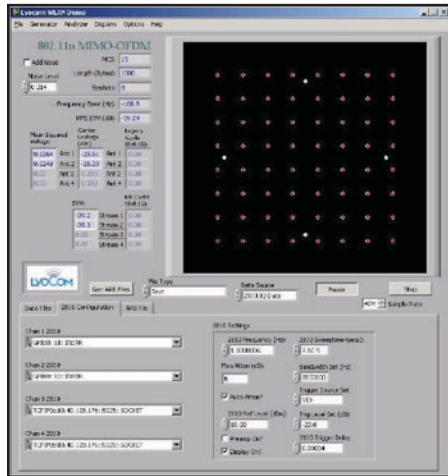

An extensive feature set makes the Model 280111 WLAN 802.11n MIMO Signal Analyzer software ideal for characterizing communications systems using MIMO technologies.

Modes of Operation

STANDARD SPECTRUM ANALYSIS MODES: Spectrum Analyzer (power envelope amplitude vs. frequency spectrum), Zero Span (power envelope amplitude vs. time), ACPR (adjacent channel power bar chart), and channel power list.

OPTIONAL VECTOR SIGNAL ANALYSIS MODES: Modulation quality measurements on GSM-GPRS-EDGE, cdmaOne-cdma2000, WCDMA FDD uplink (mobile phone transmitter signals), WCDMA FDD downlink (base station transmitter signals), and WLAN (802.11a-b-g-j-n signals).

Note: All items are specifications unless otherwise noted.

Frequency

FREQUENCY RANGE: 2820-004: 400MHz to 4.0GHz¹. 2820-006: 400MHz to 6.0GHz².

FREQUENCY SETTING RESOLUTION: 0.1Hz.

FREQUENCY ACCURACY: Same as frequency reference + synthesizer resolution term³.

INTERNAL FREQUENCY REFERENCE

AGING RATE: ≤1ppm/year.

TEMPERATURE STABILITY: ≤0.2ppm (characteristic).

FREQUENCY REFERENCE OUTPUT

IMPEDANCE: 50Ω (characteristic), AC coupled.

REFERENCE OUTPUT SIGNAL: 10MHz, +7dBm ± 3dB (characteristic).

EXTERNAL FREQUENCY REFERENCE INPUT

VARIABLE INPUT FREQUENCY MODE: 1 to 20MHz⁵.

AMPLITUDE: Lock Range: 0 to +15dBm⁶.

IMPEDANCE: 50Ω (characteristic).

NOTES

1. Over range operation provided: 325MHz to 4.0GHz. Performance below 400MHz is not specified.
2. Over range operation provided: 325MHz to 6.5GHz. Performance below 400MHz and above 6.0GHz is not specified.
3. Synthesizer resolution term: ≤20μHz.
4. Total variation relative to 0° to 50°C ambient temperature range.
5. On 10Hz boundaries Freq = 1MHz + n · 10Hz. Reference accuracy: ≤±1ppm. Sine or square wave inputs acceptable.
6. For optimum phase noise, 0 to +10dBm.



Model 2820 rear panel. Note the RF input (2820-R configuration option).

Model 2820 specifications

RF/MICROWAVE

1.888.KEITHLEY (U.S. only)

www.keithley.com

KEITHLEY

Spectrum Analysis Controls and Parameters

FREQUENCY SPAN: 2820-004: 200Hz to 3.6GHz¹. 2820-006: 200Hz to 5.6GHz². Zero span mode available.

SWEEP TIME SETTINGS IN ZERO SPAN MODE: 1μs to 30s.

SWEEP MODES: Continuous, single.

IF BANDWIDTH³:

Relative flatness over 20MHz: ±1.0dB (typical).

Relative flatness over 4MHz: ±0.5dB (typical).

3dB BW: >30MHz (typical).

6dB BW: >38MHz (typical).

RESOLUTION BANDWIDTHS: 1Hz to 3MHz (ENBW) with 1Hz resolution for spans >0Hz⁴.

RESOLUTION BANDWIDTH FILTERS (1Hz Resolution)⁵:

Brickwall: 10Hz to 35MHz, flat BW⁶.

Root Raised Cosine $\alpha = 0.22$: 10Hz to 28MHz, 3dB BW.

Gaussian: 10Hz to 7MHz, 3dB BW.

5 Pole Synchronously Tuned: 10Hz to 2.3MHz, 3dB BW.

4 Pole Synchronously Tuned: 10Hz to 1.75MHz, 3dB BW.

AMPLITUDE: Reference Level Range Setting: +40dBm to -170dBm.

Scale Settings: Manual: 0.1dB/division to 40dB/division.

PRE-AMPLIFIER: On, off.

400MHz to 2.5GHz (Char gain 15dB).

2.5GHz to 4.0GHz (Char gain 14dB).

4.0GHz to 6.0GHz (Char gain 12dB).

DISPLAY:

Detection Modes: Normal, maximum, minimum, sample, power average, power average + noise correction.

Trace Hold Displays: Normal, max hold, min hold, min/max hold.

AVERAGING: 1 – 1,000 traces⁷. **Modes:** Log, power, log group, power group, max group, min group, min/max group.

MARKERS: 4 independent markers, each with a delta marker, normal and peak modes.

Marker Amplitude Resolution: 0.01dB from front panel, 0.001dB via remote interface.

CHANNEL POWER LIST: Single command to execute up to 501 power measurements.

NOTES

- Over range operation provided: Maximum span is 3.675GHz. Performance below 400MHz is not specified.
- Over range operation provided: Maximum span is 6.175GHz. Performance below 400MHz and above 6.0GHz is not specified.
- Flatness across a given measurement span is the sum of IF flatness and RF flatness.
- RBW accuracy <1% characteristic.
- Filter types are settable in zero span, channel power list, and ACPR modes.
- ENBW $\approx 1.10 \cdot$ RBW setting. 6dB BW $\approx 1.09 \cdot$ RBW setting.
- CDMA and WCDMA measurement personalities limit number of trace averages to 100.

Spectrum Analysis Amplitude¹

MAXIMUM SAFE INPUT POWER: +35dBm.

MAXIMUM SAFE DC VOLTAGE: ± 50VDC.

ABSOLUTE ACCURACY (typical)²

325MHz to 400MHz: 0.2dB (characteristic).

400MHz ≤ Freq ≤ 2000MHz: ±0.6 (±0.2) dB.

2000MHz < Freq ≤ 6000MHz: ±0.8 (±0.4) dB.

6000MHz < Freq ≤ 6500MHz: ±5.0dB (characteristic).

REF LEVEL ACCURACY (referenced to 0dBm): +10 to -75dBm: ±0.3dB.
-75 to -100dBm: ±0.6dB.

DISPLAY SCALE FIDELITY³: ±0.2dB.

RESOLUTION BANDWIDTH SWITCHING ERROR⁴: ±0.01dB.

ATTENUATOR ACCURACY⁵:

Freq <2.5GHz: ±0.15dB for 5 through 25dB attenuator settings. ±0.25dB for 30dB attenuator setting.

Freq ≥2.5GHz: ±0.2dB for 5 through 10dB attenuator settings. ±0.25dB for 15 through 25dB attenuator settings. ±0.32dB for 30dB attenuator setting.

AMPLITUDE REPEATABILITY⁶: ±0.15dB (±0.07dB typical).

AMPLITUDE CHANGE DUE TO PREAMP ON: ±0.3dB (±0.18dB typical).

DISPLAYED AVERAGE NOISE LEVEL:

≤-136dBm/Hz, pre-amp off (F ≤2500MHz).

≤-127dBm/Hz, pre-amp off (2500MHz ≥ F ≤ 4000MHz).

≤-120dBm/Hz, pre-amp off (4000MHz ≥ F ≤ 6000MHz).

≤-146dBm/Hz, pre-amp on (F ≤2500MHz).

≤-137dBm/Hz, pre-amp on (2500MHz ≥ F ≤ 4000MHz).

≤-131dBm/Hz, pre-amp on (4000MHz ≥ F ≤ 6000MHz).

VSWR: ≤1.4:1 (characteristic).

SPURIOUS AND RESIDUAL RESPONSES

TOI (referred to the 2820 input, two 0dBm input signals and reference level = 0dBm):

F ≤2500MHz = +35dBm (characteristic). F >2500MHz = +41dBm (characteristic).

SOI (referred to the 2820 input, 0dBm input signals and reference level = 0dBm):

+50dBm (characteristic).

RESIDUALS (reference level setting ≤-40dBm): ≤-90dBm.

LO RELATED SPURS: ≤-55dBc.

NOTES

- Specifications apply when autocoupled unless otherwise stated.
- Input power at 0dBm, span = 1MHz and RBW = 100Hz.
- Signal level within 50dB of top of screen, reference level 0dBm, no change in instrument state.
- RBW switching error specified under conditions where span / RBW setting ≤15000 and frequency spans ≤25MHz.
- Only applies if input attenuator is changed from autocoupled setting.
- For repetitive CW power readings with read signal removed then reapplied for signals: >40dB above noise floor within 5 minutes.

Phase Noise

SSB PHASE NOISE, dBc/Hz:

Carrier Frequency, GHz	Freq. Offset, kHz Characteristic (Typical)					
	0.1	1.0	10	20	100	1,000
0.4	-106	-119	-124	-122	-121	-126
1.0	-102	-118	-119	(-115)	-118	-121
2.0	-97	-112	-114	-115	-113	-116
4.0	-90	-108	-111	-111	-109	-112
6.0	-89	-105	-108	-109	-107	-110

2820

RF Vector Signal Analyzer

400MHz to 4GHz or 6GHz

Generator Output

FREQUENCY RANGE¹: 400–2500MHz.

SWEEP SPAN²: 0–2100MHz.

SWEEP POINTS: 1 to 501.

DWELL SETTING: 1ms to 1s in 1ms increments.

AMPLITUDE: Fixed: –18dBm ±5.0dB (typical).

NOTES

- Over range operation provided: 325MHz to 2.7GHz. Performance below 400MHz and above 2.5GHz is not specified.
- Over range operation provided: Maximum span: 2.375GHz. Performance below 400MHz and above 2.5GHz is not specified.

Measurement Speed Characteristics

GENERAL PURPOSE MODE

SPECTRUM OR ZERO SPAN¹: 19ms.

ACPR²: 9.5ms.

ACPR/ACLR FUNCTION³

CENTER, UPPER AND LOWER ADJ, UPPER AND LOWER ALT: 9.5ms.

CENTER CHANNEL ONLY (measurement of Adj and Alt Off): 6.0ms.

CHANNEL POWER LIST FUNCTION⁴

SINGLE FREQUENCY: 0.9ms per point.

FREQUENCY STEP SIZE ≤1MHz: 1.66ms per point.

MAXIMUM READING RATE (minimum step width)⁵: 100μs per point.

GSM-EDGE PERSONALITY (GSM and GPRS Measurements)⁶

PHASE ERROR, CHANNEL POWER AND TIME MASK: 24.0ms.

PHASE ERROR AND CHANNEL POWER FREE RUN TRIGGER: 16.5ms (6.33ms/burst⁷).

PHASE ERROR AND CHANNEL POWER VIDEO TRIGGER: 16.5ms (4.73ms/burst⁷).

ORFS DUE TO MODULATION OR SWITCHING: 23.5ms.

GSM-EDGE PERSONALITY (EDGE Measurements)⁸

EVM, CHANNEL POWER AND TIME MASK: 26.3ms.

EVM AND CHANNEL POWER: 20.8ms (6.40ms/burst⁹).

ORFS DUE TO MODULATION OR SWITCHING: 24.9ms.

CDMA PERSONALITY (cdma2000 Measurements)

DEMODULATION MEASUREMENT¹⁰: 50.5ms.

ACPR: 60.7ms¹¹ (230ms¹²).

SPECTRUM EMISSIONS MASK: 125.2ms.

OCCUPIED BANDWIDTH: 51.9ms.

WCDMA PERSONALITY

DEMODULATION MEASUREMENT¹³: 60.5ms.

ACLR: 9.33ms¹⁴ (208.1ms¹⁵).

SPECTRUM EMISSIONS MASK: 129.14ms.

OCCUPIED BANDWIDTH: 45.14ms.

WLAN PERSONALITY¹⁶

802.11a: 18ms

802.11b: 38ms.

802.11j: 18ms.

802.11n 20MHz: 18ms.

802.11n 40MHz: 18ms.

MAXIMUM DISPLAY REFRESH RATE FOR A COMPLETE UPDATE OF A 640×480 PIXEL VGA SCREEN, INTERNAL DISPLAY: 30 sweeps/s (33ms/sweep).

DATA TRANSFER OVER LAN/TCP/IP: Up to 0.4MByte/s.

REMOTE TRACE DATA TRANSFER¹⁷

LAN: 5.7ms.

USB: 12.7ms.

GPIB: 20ms.

TIME TO SWITCH BETWEEN MEASUREMENTS¹⁸

WITHIN GENERAL PURPOSE MODE: 10ms.

FROM SIGNAL ANALYSIS TO GENERAL PURPOSE MODE: 10ms.

FROM GENERAL PURPOSE TO SIGNAL ANALYSIS MODE: 10ms.

WITHIN GSM-EDGE PERSONALITY: 10ms.

FROM CDMA OR WCDMA PERSONALITIES, NON-DEMODULATE TO DEMODULATE: 11ms.

FROM CDMA OR WCDMA PERSONALITIES, DEMODULATE TO NON-DEMODULATE: 1ms.

NOTES

- Instrument preset, all settings auto coupled: 300kHz ≤ span ≤ 300MHz. In zero span, sweep time ≤5ms and 1MHz BW. Time is trigger to data available.
- Fast mode on, noise correction off, range check off, randomize start off, 100μs sweep time, 4MHz BW, brickwall, display off.
- Fast mode on, noise correction off, range check off, randomize start off, 100μs sweep time, 3.84MHz BW, RRC filter, display off.
- 101 point list, 400μs acquisition time, ≥1MHz BW, brickwall, noise correction off, fast mode on, range check off, randomize start off, display off.
- ≤50μs acquisition time, ≥1MHz BW, brickwall, noise correction off, fast mode on, range check off, randomize start off, display off.
- Single burst, no averaging, display off.
- 100 averages, over range check and randomized time off.
- Single burst, no averaging, display off.
- 100 averages, over range check and randomized time off.
- Parameters measured: Rho, code domain power, RMS EVM, peak EVM, peak code domain error, frequency error, IQ offset and total channel power, display off.
- Fast mode on, noise correction off, 100μs sweep, display off.
- To preset condition accuracy, display off.
- Parameters measured: Code domain power, RMS EVM, peak EVM, peak code domain error, frequency error, IQ offset and total channel power, display off.
- Fast mode on, noise correction off, 100μs sweep, display off.
- To preset condition accuracy, display off.
- Display off, plots turned off, mean of 100 iterations, no frequency change, time includes GPIB transfer time (802.11b waveform with 504 chips).
- Zero span, sweep time 100μs, binary data transfer, 501 data points, display off.
- Display off, MEAS1:INIT;IMM;*WAI;;MEAS2:INIT;IMM;*OPC

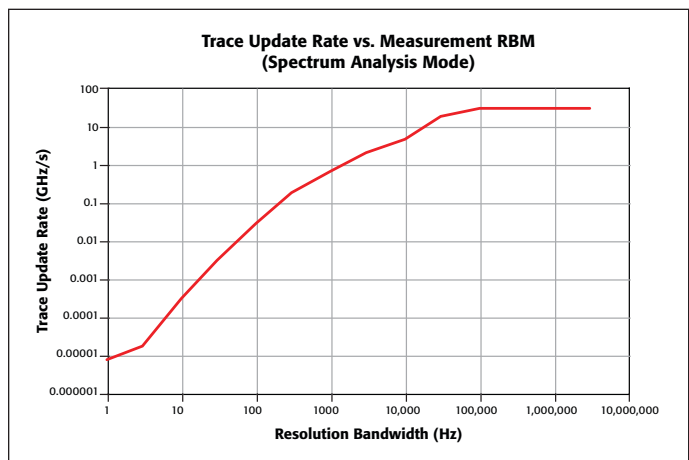

Model 2820 specifications

RF/MICROWAVE

1.888.KEITHLEY (U.S. only)

www.keithley.com

KEITHLEY

2820-GSM GSM, GPRS, and EDGE Signal Analysis Personality (Carrier ≤ 2.5 GHz)

GSM AND GPRS POWER AND MODULATION QUALITY

CHANNEL POWER:

Measurement Range: +33dBm to -30dBm (typical).
Accuracy: ± 0.6 dB (typical).

PHASE AND FREQUENCY ERROR:

Frequency Error Measurement Range: ± 50 kHz (typical).
Frequency Error Accuracy: ± 10 Hz (typical).
RMS Phase Error Measurement Range: 0° – 10° (typical).
RMS Phase Error Accuracy: $< \pm 1^\circ$.
Peak Phase Error Measurement Range¹: 0° – 25° (typical).
Peak Phase Error Accuracy¹: $\pm 2^\circ$.
Phase Error Floor: RMS: 0.35° . Peak: 1.0° .

TIME MASK CONFORMANCE:

Sampling Resolution: $0.615\mu\text{s}$ (1/6 bit).
Accuracy Along Burst Peak: 0.25 dB.
Outputs: Pass/fail, complete burst with upper and lower mask limit lines.

GSM AND GPRS OUTPUT RF SPECTRUM²

ORFS DUE TO MODULATION: Dynamic range (dBc):

Offset Frequency (kHz)	Carrier Frequency Fc (typical in parentheses)	
	400MHz \leq Fc \leq 1GHz	1GHz < Fc \leq 2GHz
200	34 (35)	34 (35)
250	39 (40)	39 (40)
400	67 (68)	63 (65)
600	73 (74)	69 (70)
1200	78 (79)	75 (76)
1800 ³	74 (75)	70 (72)

Relative Accuracy: ± 0.7 dB typical.

ORFS DUE TO SWITCHING: Dynamic range:

Offset Frequency (kHz)	Carrier Frequency Fc (typical in parentheses)	
	400MHz \leq Fc \leq 1GHz	1GHz < Fc \leq 2GHz
400	66 (67)	63 (64)
600	72 (73)	68 (70)
1200	77 (78)	75 (79)
1800	78 (79)	76 (77)

Relative Accuracy: ± 0.7 dB typical.

Displays: Power vs. time with time mask, ORFS due modulation, ORFS due to switching, phase error vs. time, symbols vs. time

NOTES

- Average of peak from each burst.
- Nominal carrier power at RF input ≥ -10 dBm. Does not include level uncertainty due to inherent noise.
- 1800kHz offset measured using 100kHz RBW. All other offsets measured using 30kHz RBW.

EDGE POWER AND MODULATION QUALITY

CHANNEL POWER:

Measurement Range: +33dBm to -30dBm (typical).
Accuracy: ± 0.6 dB (typical).

FREQUENCY ERROR:

Frequency Error Measurement Offset: ± 50 kHz (typical).
Frequency Error Accuracy: ± 10 Hz (typical).

EVM:

RMS Measurement Range: 0–15% (typical).
RMS Floor: $\leq 0.5\%$.
Origin Offset Range: -20dBc maximum (typical).
RMS Accuracy: $\pm 0.5\%$

TIME MASK CONFORMANCE:

Sampling Resolution: $0.615\mu\text{s}$ (1/6 bit) (typical).
Accuracy Along Burst Peak: ± 0.25 dB (typical).
Outputs: Pass/fail, complete burst with upper and lower mask limit lines.

EDGE OUTPUT RF SPECTRUM¹

ORFS DUE TO MODULATION: Dynamic range, dB:

Offset Frequency (kHz)	Carrier Frequency Fc (typical in parentheses)	
	400MHz \leq Fc \leq 1GHz	1GHz < Fc \leq 2GHz
200	36 (38)	36 (37)
250	40 (41)	40 (41)
400	66 (68)	63 (65)
600	72 (73)	69 (70)
1200	75 (76)	75 (76)
1800 ²	71 (72)	71 (72)

Relative Accuracy: ± 0.7 dB typical.

ORFS DUE TO SWITCHING: Dynamic range, dB:

Offset Frequency (kHz)	Carrier Frequency Fc (typical in parentheses)	
	400MHz \leq Fc \leq 1GHz	1GHz < Fc \leq 2GHz
400	65 (67)	62 (64)
600	70 (72)	68 (69)
1200	74 (75)	74 (75)
1800	75 (76)	75 (76)

Relative Accuracy: ± 0.7 dB typical.

Displays: Power vs. time with time mask, ORFS due modulation, ORFS due to switching, EVM vs. time, symbols vs. time, constellation.

NOTES

- Nominal carrier power at RF input ≥ -10 dBm. Does not include level uncertainty due to inherent noise.
- 1800kHz offset measured using 100kHz RBW. All other offsets measured using 30kHz RBW.

2820

RF Vector Signal Analyzer

400MHz to 4GHz or 6GHz

MODEL 2820-CDMA2000-R: Reverse Link Signal Analysis Personality (Carrier \leq 2.5GHz)

CHANNEL POWER: Measurement Range: +33dBm to -70dBm (typical)
Accuracy (1.2288MHz BW): ± 0.6 dB (typical).

FREQUENCY ERROR: Frequency Error Measurement Range: ± 3 kHz (typical).
Frequency Error Accuracy: ± 10 Hz (typical).

RHO (ρ): Range: 0.7–1.0 (typical).
Ceiling: > 0.9995 .
Accuracy: ± 0.005 (for ρ values > 0.9).

CODE DOMAIN POWER:
Relative accuracy, for code channels ≥ -20 dB of total power: ± 0.3 dB (typical).

ADJACENT CHANNEL POWER¹:
Dynamic Range: 70dBc @ 885kHz offset (typical). 82dBc @ 1980kHz offset (typical).

RELATIVE ACCURACY: ± 0.5 dB typical.

OCCUPIED BANDWIDTH: Frequency Accuracy: ± 5 kHz (typical).

SPECTRUM EMISSIONS MASK¹: Accuracy Relative to Carrier Power: < 0.5 dB.

DISPLAYS: Code domain power, adjacent channel power with limits, occupied bandwidth with limit lines, conducted spurious emissions with limits.

1. Carrier power at RF input ≥ -10 dBm. Does not include level uncertainty due to inherent noise.

MODEL 2820-WCDMA-U: Uplink Signal Analysis Personality (Carrier = 1800MHz–2200MHz)

CHANNEL POWER: Measurement Range: +33dBm to -60dBm (typical).
Accuracy (3.84MHz BW): ± 0.6 dB (typical).

FREQUENCY ERROR: Frequency Error Measurement Range: ± 3 kHz (typical).
Frequency Error Accuracy: ± 10 Hz (typical).

RMS EVM: Range: 0%–25% (typical). Floor: 1.9% (typical). Accuracy: $\pm 2\%$.

CODE DOMAIN POWER:
Relative Accuracy, for code channels ≥ -20 dB of total power: ± 0.3 dB.

ADJACENT CHANNEL POWER¹: Dynamic Range: 63dBc @ 5MHz offset (typical).
69dBc @ 10MHz offset (typical).

RELATIVE ACCURACY: ± 0.5 dB (typical).

OCCUPIED BANDWIDTH: Frequency Accuracy: ± 20 kHz (characteristic).

SPECTRUM EMISSIONS MASK¹: Accuracy Relative to Carrier Power: < 1.5 dB (characteristic).

DISPLAYS: Code domain power, adjacent channel power with limits, occupied bandwidth with limit lines, spectrum emissions with limits.

1. Carrier power at RF input ≥ -10 dBm. Does not include level uncertainty due to inherent noise.

MODEL 2820-WCDMA-D: Downlink Signal Analysis Personality (Carrier = 1800MHz–2200MHz)

CHANNEL POWER: Measurement Range: +33dBm to -60dBm (typical).
Accuracy (3.84MHz BW): ± 0.6 dB (typical).

FREQUENCY ERROR: Frequency Error Measurement Range: ± 3 kHz (typical).
Frequency Error Accuracy: ± 10 Hz (typical).

RMS EVM: Range: 0%–25% (typical). Floor: 1.9% (typical). Accuracy: $\pm 2\%$. Symbol EVM¹: 0.25%.

CODE DOMAIN POWER:
Relative Accuracy, for code channels ≥ -20 dB of total power: ± 0.3 dB.

ADJACENT CHANNEL POWER²: Dynamic Range: 63dBc @ 5MHz offset (typical).
69dBc @ 10MHz offset (typical).

RELATIVE ACCURACY: ± 0.5 dB (typical).

OCCUPIED BANDWIDTH: Frequency Accuracy: ± 20 kHz (characteristic).

SPECTRUM EMISSIONS MASK²: Accuracy Relative to Carrier Power: < 1.5 dB (characteristic).

DISPLAYS: Code domain power, adjacent channel power with limits, occupied bandwidth with limit lines, spectrum emissions with limits.

NOTES

- Valid for CPICH only signal.
- Carrier power at RF input ≥ -10 dBm. Does not include level uncertainty due to inherent noise.

MODEL 2820-80211: Wireless LAN Signal Analysis Personality

CHANNEL POWER

MEASUREMENT RANGE:
Carrier Frequency 2.4GHz: +33dBm to -60dBm (typical).
Carrier Frequency 4.9 and 5.8GHz: +15dBm to -60dBm (typical).

ACCURACY: OFDM 20MHz: ± 0.85 dB (typical).
OFDM 40MHz: ± 0.85 dB (typical).
DSSS/CCK: ± 0.85 dB (typical).

FREQUENCY ERROR

MEASUREMENT RANGE: OFDM: ± 312 kHz.
DSSS/CCK: ± 100 kHz.

ACCURACY: ± 10 Hz (typical).

RMS EVM FLOOR¹, Typical (Characteristic):

802.11a: -38dB (-41.9dB) @ 5.8GHz.
802.11g: -41dB (-44.8dB) @ 2.4GHz.
802.11j: -38dB (-41.9dB) @ 4.9GHz.
802.11n 20MHz²: -40dB (-44.1dB) @ 2.4GHz.
-36dB (-41.0dB) @ 5.8GHz.
802.11n 40MHz²: -35dB (-40.3dB) @ 5.8GHz.
802.11b: -44dB @ 2.4GHz.

CHANNEL FLATNESS MASK MARGIN:

OFDM 20MHz: 1.4dB (typical) at 2.4 and 5.8GHz.
OFDM 40MHz: 1.0dB (typical) at 5.8GHz.

NOTES

- Applies when input signal is above -20dBm, with Expected Channel Power set equal to input power.
- Measuring 802.11n MIMO signals can degrade the EVM floor by as much as 3dB.

2820

RF Vector Signal Analyzer

400MHz to 4GHz or 6GHz

Trigger and Synchronization Inputs and Outputs

- TRIGGER SOURCES¹:** Free run
External
Video
Bus
External arm using video trigger
Bus arm using external or video trigger
Latched External
- TRIGGER DELAY:** -30 to +30 seconds.
- TRIGGER MODES:** On measurement.
On acquire.
- EXTERNAL TRIGGER:** Selectable on rising or falling edge of external input.
Input level TTL.
Minimum input pulse width required 50ns (characteristic).
- VIDEO TRIGGER MODES:** Selectable on rising or falling signal edge.
Video level.
Pre-qualification mode level and time settings
- SYNC OUTPUT MODES:** Generate a sync pulse:
• Off
• Begin measurement
• Start tune
• Ready acquire
• Start acquire
• End acquire
• End measurement
- SYNC OUTPUT POLARITY SELECT:** Sync out is on the falling or rising edge.
- SYNC OUTPUT:** TTL level. Minimum pulse width 200ns (characteristic).
- EVEN SECOND CLOCK INPUT:** External even second clock (TTL).
- EVEN SECOND CLOCK OUTPUT:** External even second clock (TTL).

1. Bus trigger and bus arm available only in channel power list mode.

GENERAL SPECIFICATIONS

- POWER:** 100VAC to 240VAC; 50/60 Hz (automatically detected); 150VA max.
- CE EMC COMPLIANCE:** EU Directive 89/336/EEC; EN 61326-1.
- CE SAFETY COMPLIANCE:** CE; EU Directive 73/23/EEC, EN 61010-1.
- CALIBRATION:** Annual calibration cycle in system.
- ENVIRONMENT (for indoor use only):**
18° to 23°C specified operating, unless otherwise noted.
0° to 50°C operating survival, non-specified operation.
-25°C to 65°C non-operating (AC power off) storage.
Altitude: Maximum 2000 meters above sea level.
Cooling: Forced air top, bottom, and side intakes and rear exhaust. For proper cooling in a rack, use Keithley Instruments 2910-RMK Rack Mount Kit.
- DIGITAL INPUTS/OUTPUTS:** 4 bits, TTL-compatible.
- INTERFACES:** IEEE-488.1 compliant. Supports IEEE-488.2 common commands and status model topology.
- LAN:** 10/100BT Ethernet, RJ45, LXI Class C, no auto MDIX.
- IVI-COM.**
- USB:** USB full speed.
- RF in/TG out:** Type N connector.
- MECHANICAL VIBRATION AND SHOCK:**
MIL-PRF-2880 CL3 random vibration, 3 axes.
Sine-Sweep test for resonances, 3 axes.
MIL-STD-810F 516.5 paragraph, 4.5.7 procedure VI bench drop MIL-PRF-2880 CL3 random vibration, 3 axes.
- GENERAL MECHANICAL CHARACTERISTICS:**
Height: 3U (133mm) (5.25").
Width: Half-rack (213mm) (8.4").
Depth: 464mm (18.25").
Weight: 7.5kg (16.5 lbs.).
- WARRANTY:** 1 year.

SPECIFICATION NOTES

Specifications describe the instrument's warranted performance. Typical and characteristic values are not warranted, but provide additional information regarding performance that you should expect from the Model 2820 and are provided to assist in application of the Model 2820.

SPECIFICATIONS (warranted performance):

Specifications indicate performance that is warranted. All units are warranted to meet these performance specifications under the following conditions:

- Ambient operating temperature of 18° to 28°C, unless otherwise noted.
- After a warm-up time of 30 minutes and self calibration at ambient temperature.

TYPICAL (mean + 3 standard deviations):

Typical indicates performance that units will meet under the following conditions:

- Ambient operating temperature of 23°C, unless otherwise noted.
- After a warm-up time of 30 minutes and self calibration at ambient temperature.

This performance is not warranted.

CHARACTERISTIC (mean or expected value):

Characteristic indicates performance that a unit would be expected to exhibit under the following conditions:

- Ambient operating temperature of 23°C, unless otherwise noted.
- After a warm-up time of 30 minutes and self calibration at ambient temperature.

This performance is not warranted.

Model 2820 specifications

RF/MICROWAVE

1.888.KEITHLEY (U.S. only)

www.keithley.com

KEITHLEY

2820

RF Vector Signal Analyzer

400MHz to 4GHz or 6GHz

Signal analyzer for RF communications testing

Specifications are subject to change without notice.
All Keithley trademarks and trade names are the property of Keithley Instruments, Inc.
All other trademarks and trade names are the property of their respective companies.



A G R E A T E R M E A S U R E O F C O N F I D E N C E

KEITHLEY INSTRUMENTS, INC. ■ 28775 AURORA ROAD ■ CLEVELAND, OHIO 44139-1891 ■ 440-248-0400 ■ Fax: 440-248-6168 ■ 1-888-KEITHLEY ■ www.keithley.com

BELGIUM

Sint-Pieters-Leeuw
Ph: 02-3630040
Fax: 02-3630064
info@keithley.nl
www.keithley.nl

CHINA

Beijing
Ph: 8610-82255010
Fax: 8610-82255018
china@keithley.com
www.keithley.com.cn

FINLAND

Espoo
Ph: 09-88171661
Fax: 09-88171662
finland@keithley.com
www.keithley.com

FRANCE

Saint-Aubin
Ph: 01-64532020
Fax: 01-60117726
info@keithley.fr
www.keithley.fr

GERMANY

Germering
Ph: 089-84930740
Fax: 089-84930734
info@keithley.de
www.keithley.de

INDIA

Bangalore
Ph: 080-26771071, -72, -73
Fax: 080-26771076
support_india@keithley.com
www.keithley.com

ITALY

Peschiera Borromeo (Mi)
Ph: 02-5538421
Fax: 02-55384228
info@keithley.it
www.keithley.it

JAPAN

Tokyo
Ph: 81-3-5733-7555
Fax: 81-3-5733-7556
info.jp@keithley.com
www.keithley.jp

KOREA

Seoul
Ph: 82-2-574-7778
Fax: 82-2-574-7838
keithley@keithley.co.kr
www.keithley.co.kr

MALAYSIA

Penang
Ph: 60-4-656-2592
Fax: 60-4-656-3794
chan_patrick@keithley.com
www.keithley.com

NETHERLANDS

Gorinchem
Ph: 0183-635333
Fax: 0183-630821
info@keithley.nl
www.keithley.nl

SINGAPORE

Singapore
Ph: 65-6747-9077
Fax: 65-6747-2991
koh_william@keithley.com
www.keithley.com.sg

SWEDEN

Solna
Ph: 08-50904600
Fax: 08-6552610
sweden@keithley.com
www.keithley.com

SWITZERLAND

Zürich
Ph: 044-8219444
Fax: 044-8203081
info@keithley.ch
www.keithley.ch

TAIWAN

Hsinchu
Ph: 886-3-572-9077
Fax: 886-3-572-9031
info.kei@keithley.com.tw
www.keithley.com.tw

UNITED KINGDOM

Theale
Ph: 0118-9297500
Fax: 0118-9297519
info@keithley.co.uk
www.keithley.co.uk

RF/MICROWAVE