



Advanced Test Equipment Rentals
www.atecorp.com 800-404-ATEC (2832)

BARNSTEAD|THERMOLYNE CORPORATION

Type FB1300 & FB1400 Furnaces

OPERATION AND REPAIR MANUAL
AND PARTS LIST
SERIES 1049 & 1050

Model Numbers

FB1310M, FB1310M-26, FB1314M, FB1315M, FB1318M, FB1310M-33
FB1410M, FB1410M-26, FB1414M, FB1415M, FB1418M, FB1410M-33

Table of Contents

- Safety Information3
 - Important Information.....3
 - Warnings4
- Introduction.....5
 - Intended Use5
 - General Usage.....5
 - Principles of Operation5
- General Specifications6
 - Declaration of Conformity7
- Installation9
 - Unpacking9
 - Site Selection.....9
 - Electrical Connections9
- Operation10
 - Power Switch10
 - Cycle Light10
 - Door Safety Switches10
 - Digital Readout10
 - Push To Set Temperature Button.....11
 - Temperature Adjustment Knob.....11
 - Digital Control.....11
 - Sensor Break Protection12
- Furnace Loading13
- Preventive Maintenance.....14
- Troubleshooting15
- Maintenance and Servicing16
 - To Replace Heating Element16
 - To Replace Thermocouple.....19
 - To Replace Insulation21
 - To Replace Door Switches22
 - To Replace Solid State Relay23
 - To Replace PC Board (Controller)24
- Wiring Diagram.....25
- Exploded View26
- Replacement Parts List27
- Ordering Procedures28
- One Year Limited Warranty29

Safety Information

Alert Signals



Warning

Warnings alert you to a possibility of personal injury.



Caution

Cautions alert you to a possibility of damage to the equipment.



Note

Notes alert you to pertinent facts and conditions.



Hot Surface

Hot surfaces alert you to a possibility of personal injury if you come in contact with a surface during use or for a period of time after use.

Important Information

This manual contains important operating and safety information. You must carefully read and understand the contents of this manual prior to the use of this equipment.

Your Thermolyne FB1300 Model or FB1400 Model Furnace has been designed with function, reliability, and safety in mind. It is your responsibility to install it in conformance with local electrical codes. For safe operation, please pay attention to the alert signals throughout the manual.

Warnings

To avoid electrical shock, this furnace must:

1. Use a properly grounded electrical outlet of correct voltage and current handling capacity.
2. Be disconnected from the power supply before servicing.
3. Have the door switch operating properly.

To avoid burns:

1. "Caution: Hot Surface. Avoid Contact."
Do not touch the exterior or interior surfaces of the furnace during use or for a period of time after use.

To avoid personal injury:

1. Do not use in the presence of flammable or combustible materials — fire or explosion may result. This device contains components which may ignite such material.
2. Refer servicing to qualified personnel.

SAFETY INFORMATION

Please note the following WARNINGS:

WARNING

This warning is presented for compliance with California Proposition 65 and other regulatory agencies and only applies to the insulation in this product. This product contains refractory ceramic, refractory ceramic fiber or fiberglass insulation, which can produce respirable dust or fibers during disassembly. Dust or fibers can cause irritation and can aggravate preexisting respiratory diseases. Refractory ceramic and refractory ceramic fibers (after reaching 1000°C) contain crystalline silica, which can cause lung damage (silicosis). The International Agency for Research on Cancer (IARC) has classified refractory ceramic fiber and fiberglass as possibly carcinogenic (Group 2B), and crystalline silica as carcinogenic to humans (Group 1).

The insulating materials can be located in the door, the hearth collar, in the chamber of the product or under the hot plate top. Tests performed by the manufacturer indicate that there is no risk of exposure to dust or respirable fibers resulting from operation of this product under normal conditions. However, there may be a risk of exposure to respirable dust or fibers when repairing or maintaining the insulating materials, or when otherwise disturbing them in a manner which causes release of dust or fibers. By using proper handling procedures and protective equipment you can work safely with these insulating materials and minimize any exposure. Refer to the appropriate Material Safety Data Sheets (MSDS) for information regarding proper handling and recommended protective equipment. For additional MSDS copies, or additional information concerning the handling of refractory ceramic products, please contact the Customer Service Department at Barnstead|Thermolyne Corporation at 1-800-553-0039.

Introduction

Intended Use

The FB1300 Model and FB1400 Model furnaces are general purpose laboratory and heat treating furnaces. For optimum element life, observe the following temperature ranges: 100°C (212°F) to 982°C (1800°F) for continuous use, or from 982°C (1800°F) to 1100°C (2012°F) for intermittent use. Continuous use is operating the furnace for more than three straight hours, and intermittent use is operating the furnace for less than three hours.

The unit consists of a heating chamber and a digital controller. See Figure 1 for the overall shape and general features of the unit.

General Usage

Do not use this product for anything other than its intended usage.

Principles of Operation

The furnace chamber is heated by a single three section resistant heater which is embedded in a refractory material. The chamber is insulated with a ceramic fiber insulation. The temperature is controlled by an electronic control which provides one temperature setting. The temperature is measured by a thermocouple and is registered on a digital display. For safety, door switches are incorporated to remove power from the heating elements when the door is opened. The furnace is supported by the control unit which also houses the electrical connections.

General Specifications

FB1300 Models

Dimensions: (handle not included)

Chamber: 4" W x 3.75" H x 4.5" D (10 x 9.5 x 11 cm)

Overall : 7.9" W x 13.2" H x 8.5" D (20 x 33.5 x 22 cm)

Weight: 15.4 lb. (7 kg)

Electrical Ratings:

<u>Model #</u>	<u>Volts</u>	<u>Amps</u>	<u>Watts</u>	<u>Phase</u>	<u>Frequency</u>
FB1310M	220-240	4.4	1050	1	50/60
FB1310M-26	220-240	4.4	1050	1	50/60
FB1310M-33	220-240	4.4	1050	1	50/60
FB1314M	100	10.5	1050	1	50/60
FB1315M	120	8.8	1050	1	50/60
FB1318M	208	5.0	1050	1	50/60

Temperature: Operating Range (continuous): 982°C; (intermittent): 1100°C.

Environmental Conditions:

Operating: 17°C - 27°C; 20% - 80% relative humidity, non-condensing. Installation

Category II (over-voltage) in accordance with IEC 664. Pollution Degree 2 in accordance with IEC 664. Altitude limit: 2,000 meters.

Storage: -25°C - 65°C; 20% - 80% relative humidity.

FB1400 Models

Dimensions: (handle not included)

Chamber: 5" W x 4.25" H x 6" D (13 x 11 x 15 cm)

Overall: 9.7" W x 15.4" H x 11.1" D (25 x 39 x 28 cm)

Weight: 23 lb. (10.4 kg)

Electrical Ratings:

<u>Model #</u>	<u>Volts</u>	<u>Amps</u>	<u>Watts</u>	<u>Phase</u>	<u>Frequency</u>
FB1410M	220-240	6.3	1500	1	50/60
FB1410M-26	220-240	6.3	1500	1	50/60
FB1410M-33	220-240	6.3	1500	1	50/60
FB1414M	100	14.4	1500	1	50/60
FB1415M	120	12.5	1500	1	50/60
FB1418M	208	7.2	1500	1	50/60

Temperature: Operating Range (continuous): 982°C; (intermittent): 1100°C.

Environmental Conditions:

Operating: 17°C - 27°C; 20% - 80% relative humidity, non-condensing. Installation

Category II (over-voltage) in accordance with IEC 664. Pollution Degree 2 in accordance with IEC 664. Altitude limit: 2,000 meters.

Storage: -25°C - 65°C; 20% - 80% relative humidity.

Declaration of Conformity

Barnstead|Thermolyne hereby declares under its sole responsibility that this product conforms with the technical requirements of the following standards (-33 models only):

EMC: EN 50081-1 Generic Emission Standard;
EN 50082-1 Generic Immunity Standard.
Safety: EN 1010-1-92 Safety requirements for electrical equipment for measurement, control and laboratory use; Part I: General Requirements
EN 1010-2-010 Part II: Particular requirements for laboratory equipment for the heating of materials

per the provisions of the Electromagnetic Compatibility Directive 89/336/EEC, as amended by 92/31/EEC and 93/68/EEC, and per the provisions of the Low Voltage Directive 73/23/EEC, as amended by 93/68/EEC.

The authorized representative located within the European Community is:

Electrothermal Engineering, Ltd.
419 Sutton Road
Southend On Sea
Essex SS2 5PH
United Kingdom

Copies of the Declaration of Conformity are available upon request.

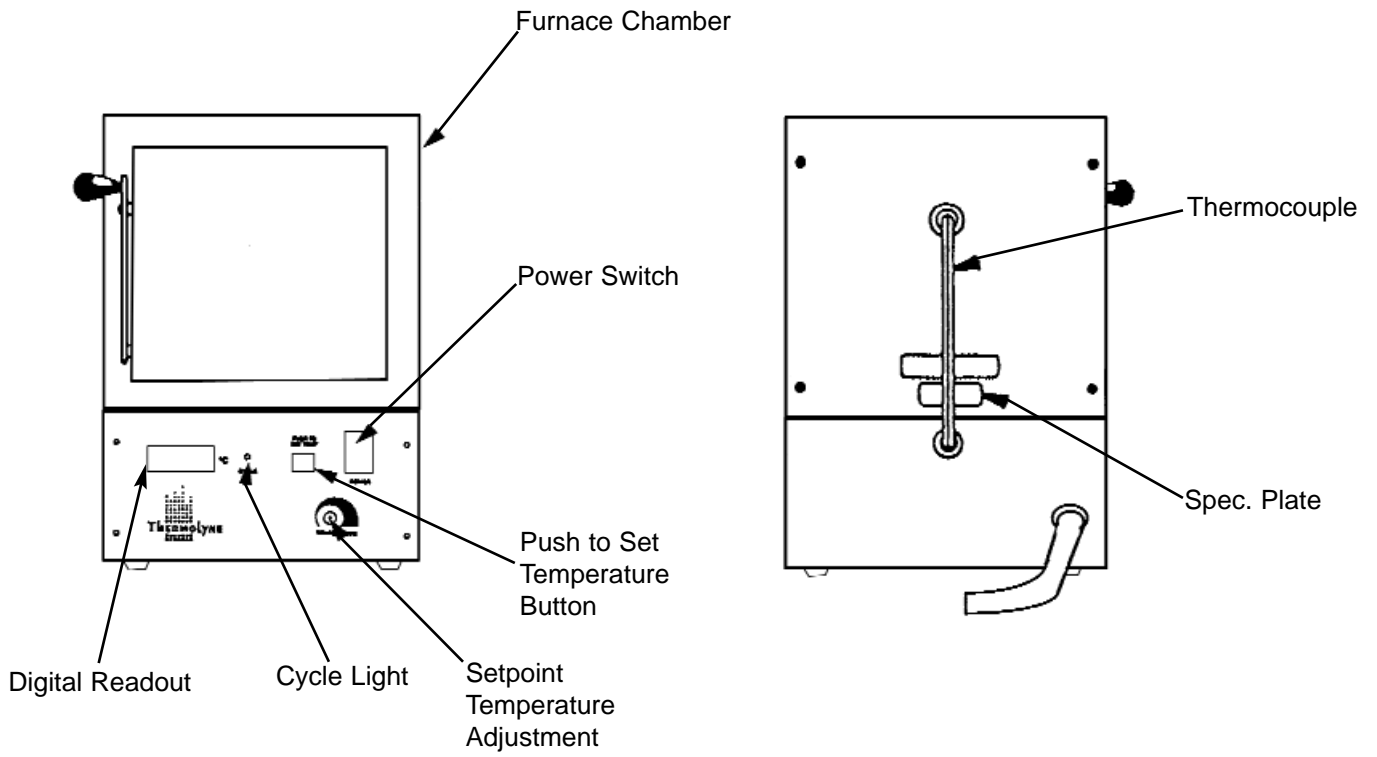

Figure 1: Front and Back Views

Installation



Warning

Do not mount on a surface of flammable material. The furnace should be installed at least six inches away from any combustible material.



Warning

Use a properly grounded electrical outlet of correct voltage and current handling capacity.

Unpacking

Unpack furnace from the box and remove packing material from inside furnace chamber. The furnace is supplied with a three wire cord and plug.

Site Selection

Install furnace on a sturdy surface and allow space for ventilation. The furnace should be installed at least six inches away from any combustible material.

Electrical Connections

The electrical specifications are located on the specification plate on the back of the furnace. Consult Barnstead/Thermolyne if your electrical service is different than those listed on the specification plate. Prior to connecting your furnace to your electrical supply, be sure the ON/OFF switch is in the OFF position.

Operation



Warning

Do not use in the presence of flammable or combustible materials — fire or explosion may result. This device contains components which may ignite such material.

To avoid electrical shock, this furnace must have the door switch operating properly.



Hot Surface

Caution: Avoid Contact. Do not touch the exterior or interior surfaces of the furnace during use or for a period of time after use.

Power Switch

When power is switched ON, the On/OFF power switch will illuminate and the digital display will illuminate.

Cycle Light

The amber cycle light will illuminate whenever the power is being applied to the heating elements. The cycle light will flicker on/off as furnace reaches setpoint.

Door Safety Switches

The door safety switches remove power from the heating elements when the door is opened. Open and close the door a few times; note that the amber CYCLE light will be out when door is open. This check must be done when furnace is heating or when cycle light is illuminated. If this condition is not true, consult the Troubleshooting section before proceeding.

Digital Readout

The digital readout continuously displays chamber temperature unless the Push To Set Temperature button is depressed. Then setpoint temperature is displayed.

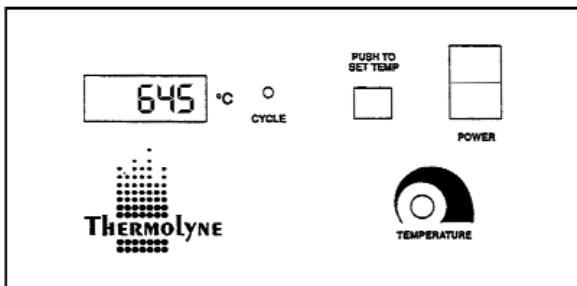

Figure 2: Digital Control

**Note**

If at any time the Temperature Adjustment knob is turned in either direction, the setpoint will change, even if the Push To Set Temperature button is not depressed. To view the current setpoint temperature, depress the Push To Set Temperature button.

Push To Set Temperature Button

When this button is depressed, the digital display will indicate setpoint temperature. When the button is released, the actual chamber temperature is displayed.

Temperature Adjustment Knob

Turning this knob clockwise will increase setpoint temperature. Turning the knob counterclockwise will decrease temperature.

Digital Control

This digital controller provides accurate control at one single temperature setting. To set temperature, simply:

1. Turn Power switch ON.
2. While depressing the Push To Set Temperature button, turn the temperature knob until you reach the desired setpoint temperature as indicated on digital display.
3. Release the Push To Set Temperature button.

The digital display will now indicate the actual chamber temperature. The furnace will heat to the new setpoint temperature. The CYCLE light will remain on until the furnace temperature is within 1°C of the setpoint temperature; then the CYCLE light will flicker on and off as the controller maintains the setpoint temperature.

Sensor Break Protection

This controller provides sensor break protection in the event the thermocouple opens. If an open thermocouple condition occurs, the digital display will indicate 5 degrees or less and the power to the heating element will be shut off (CYCLE light will extinguish).

Furnace Loading



Caution

Do not overload your furnace chamber or allow the load to touch the thermocouple. If the load is to be heated uniformly, it should not occupy more than two-thirds of any dimension of the chamber. Failure to observe these cautions could result in damage to furnace components and/or load.

- For best results of furnace loading, use less than two-thirds of any dimension of the chamber. Maintain a 3/4" clearance between the load and the sides of the chamber.
- If you are heating a number of small parts, spread them throughout the middle two thirds of the chamber.
- Keep objects away from thermocouple.
- Raise your load up off the furnace floor with small pieces of ceramic or a hearth plate to promote even heating.
- Use insulated tongs and mittens when loading and unloading furnace.
- Always wear safety glasses.

Preventive Maintenance



Warning

Before using any cleaning or decontamination method except those recommended by Barnstead|Thermolyne, users should check with Barnstead|Thermolyne that the proposed method will not damage the equipment.



Warning

Disconnect the furnace from power supply before cleaning.

Contamination is a major cause of element failure, therefore, when possible, remove the fume forming material before heating (e.g., cleaning cutting oil from tool steel).

The resistance wire is high-grade nickel-chromium. Some chemicals, notably sulphur, halogens, and cyanides, attack this wire at high temperatures, so avoid spilling these chemicals in the furnace or heating them any hotter than necessary. The refractory cement helps to protect the wire, but will not completely immunize it from damage.

All heating elements must be considered expendable, and replacement is expected; however, reasonable care in their use will greatly extend the service they will give. As the manufacturer has no control over the use or care of the elements, no specific service guarantee can be made.

Housekeeping is vital to your electric furnace—KEEP IT CLEAN! Run your furnace up to 871°C (1600°F) empty occasionally to burn off the contamination that may exist on the insulation and elements. Run for approximately two hours with the door slightly open.

Element life is reduced somewhat by repeated heating and cooling. If the furnace is to be used again within a few hours, it is best to keep it at the operating temperature or at a reduced level such as 260°C (500°F).

During normal use, the thermocouple in your furnace can become oxidized and cause inaccurate readings; therefore, we suggest that if you regularly use your furnace you should change your thermocouple once every six months to assure the accuracy of your controller readings.

Clean by wiping the outside case of the unit with a damp cloth and mild soap solution.

Troubleshooting

The Troubleshooting section is intended to aid in defining and correcting possible furnace problems. When using the chart, select the problem category that resembles the malfunction. Then proceed to the possible causes category and take necessary corrective action.

<u>Problem</u>	<u>Possible Causes</u>	<u>Corrective Action</u>
The furnace does not heat (CYCLE light does not illuminate).	No power. Defective electrical hookup. Thermocouple has oxidized and opened the circuit. (Open thermocouple is indicated on the display as a temperature of 0-5 degrees). Controller malfunction. Door switches malfunction. Defective solid state relay.	Check power source and fuses or breakers. Repair electrical hookup. Replace thermocouple. Replace controller. Re-align or replace door safety switches. Replace output relay.
Door switches do not cut power to heating elements.	Door switches are not functioning.	Re-align or replace door switches.
Slow heatup.	Low line voltage. Heavy load in chamber. Wrong heating element.	Install line of sufficient size and proper voltage. (Isolate furnace from other electrical loads.) Lighten load in chamber to allow heat to circulate. Install proper element.
Repeated element burnout.	Overheating furnace. Heating harmful materials. Contamination present from pervious burnout.	Keep furnace under maximum temperature. Enclose material in container. Clean up spills in and on chamber. Ventilate chamber by opening door slightly when heating known harmful reagents. Replace insulation material.
Inaccurate temperature readout.	Oxidized or contaminated thermocouple. Poor thermocouple connection. Improper loading procedures. Poor ventilation of base. Thermocouple connections reversed. (Indicated by downscaling or temperature on display.) Controller malfunction.	Replace thermocouple. Tighten connections. Use proper loading procedures. Clear area around furnace base. Reconnect thermocouple correctly. Replace controller.

Maintenance and Servicing



Warning

Disconnect the furnace from the power supply before servicing. Refer servicing to qualified personnel.



Note

Perform only maintenance described in this manual. Contact an authorized dealer or our factory for parts and assistance.



Note

It is seldom necessary to disconnect the thermocouple from the controller if the thermocouple is in good condition.

To Replace Heating Element

1. Set the furnace on its top. (See Figure 3). Remove thermocouple cover.
2. Remove screw and clamp holding thermocouple, then grasp the thermocouple at the bend where it enters the furnace chamber and pull straight back. Retain porcelain feed-through insulator.
3. When the thermocouple tip is clear of the furnace back, bend it out of the way.
4. Remove the screws holding the steel back plate to the case.
5. Remove the steel back plate.

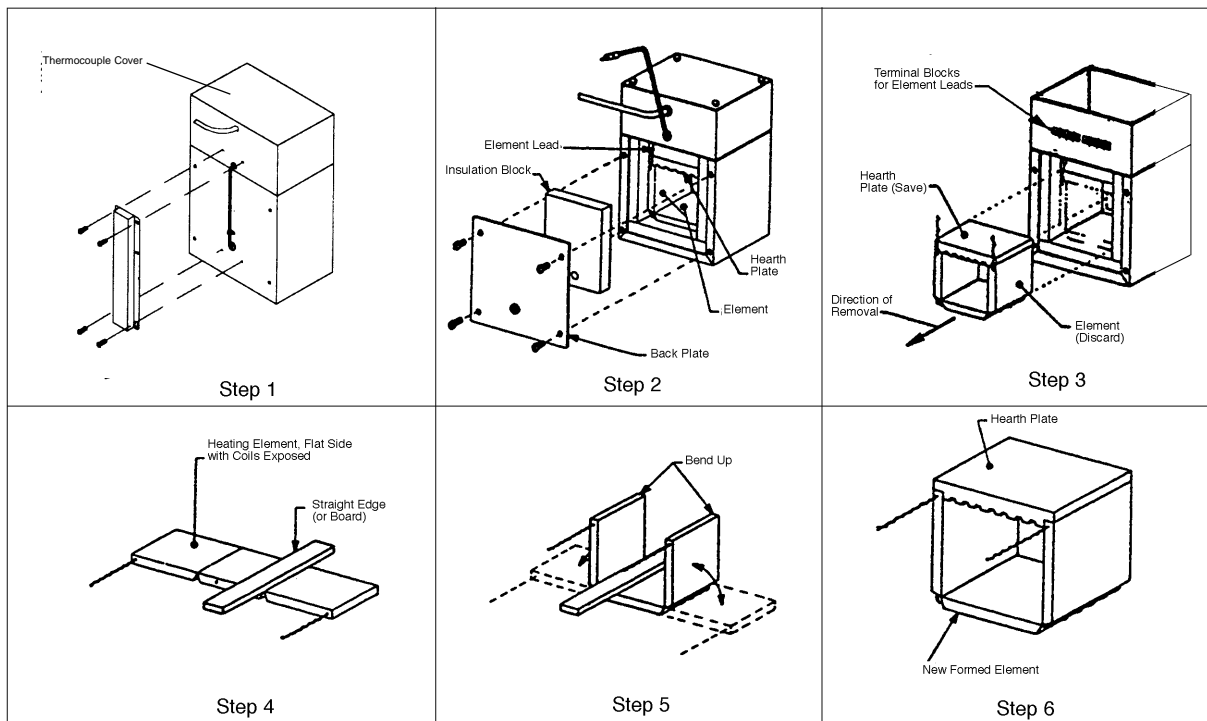

Figure 3: Replacement of a Heating Element

6. Remove the back insulation block by opening the door and gently pushing it out. Support this insulation block while removing it, as it is quite soft and easily crumbled at the edges.
7. Remove bottom cover to obtain access to terminals.

These steps will expose the heating element leads and insulating bushings in the bottom plate of the furnace.



Note

The hearth plate contains no heating coil, and may be saved for re-installation if it is in good condition. The hearth plate is replaceable independent of the heating element.

8. Cut the element leads between the element and the terminal block. (There are two leads.) The element and hearth plate unit may now be removed by pushing it straight back out of the furnace. Use care not to damage the chamber insulation when removing the hearth plate and element as it can be reused if it has not been contaminated.
9. Remove the old element lead wire and power wires from the terminal block, and save the glass sleeving for re-installation on the new element leads. Sleeving must be replaced if cracked or brittle!
10. New elements are shipped flat to protect them from damage in shipment, and to save space in storage. They must be formed before installation.
11. Place the element on a flat surface with the smooth (exposed element) side up. Place a board or other straight edge along one row of notches.
12. Gently bend the element along the straight edge. The refractory cement will break along the row of notches.

Make the bend 90°, avoiding excessive bending. (The element wires will be exposed at the corner thus formed. This will not affect its life or performance.)

13. Bend the other side of the element.
14. Place the hearth plate across the open end of the "U" shaped element.
15. Slide the element and hearth plate unit into the chamber, pushing it firmly against the hearth collar. Use care not to damage the soft insulation. Remove any crumbs of insulation that may get between the unit and the hearth collar.
16. Thread the element leads through the ceramic bushings. Bend the leads so they lie close to the refractory plate and the bottom insulation block. (The easiest and safest way to do this is to press the wire flat with a stick or blunt pusher. Do not use a sharp object or nick the wire.)
17. Replace the glass sleeving and bend the lead 3/4 turn around the terminal screw. Cut off the excess wire. Replace power wires on top of element lead wires and tighten screw. Do not cross the wire over itself around the terminal; this makes it difficult to keep the connection tight and prevents good electrical contact. If you have excess wire, cut it off. Make sure element lead wires are not touching any other wires.
18. Replace bottom cover of control unit.



Note

Nicking or damaging the element leads will cause premature element failure.

19. Replace the back insulation block and back plate.
20. Examine the thermocouple, and, if it is good, reinsert it into the chamber. It should extend about 1-1/2" into the chamber. Make sure porcelain insulator is in place for the thermocouple to pass through on the steel back plate. Replace clamp and screw. (Excessive scaling, pitting, or cracks are some indications that the thermocouple may need to be replaced.)
21. Replace thermocouple cover.
22. If replacement of back insulation is necessary, carefully redrill hole for thermocouple, using back cover as guide.
23. Reconnect furnace to power supply.
24. Test operation of furnace.



Warning

Disconnect the furnace from the power supply before servicing.

To Replace Thermocouple

1. Set furnace on its top.
2. Remove thermocouple cover.
3. Remove screw and clamp holding the thermocouple, then grasp the thermocouple at the bend where it enters the chamber and pull it straight back from the furnace. Retain porcelain feed-through insulator.
4. Remove bottom cover.



Note

If the thermocouple touches metal, this could short out the signal, causing the control to display room temperature. This could cause the furnace temperature to run away, possibly damaging furnace components.



Note

If the furnace temperature moves downward, the thermocouple leads are reversed.

- 5) Disconnect the thermocouple from the terminal block by removing the screws on the terminals. Pull the thermocouple through the hole in the furnace base and discard.
- 6) Insert the new thermocouple into the back of the furnace until the tip extends 1-1/2" into the chamber. Make sure the porcelain insulator extends through the steel back plate to prevent the lead wires from touching metal.
- 7) Bend the thermocouple sharply so that it lies flat along the back of the furnace.
- 8) Thread the thermocouple through the hole in the base which has a nylon insulator, replace clamp and screw.
- 9) Bend the thermocouple sharply toward terminal block.
- 10) Secure the two yellow wires marked "+" together on the terminal block. Secure the two red wires "-" together on the adjacent terminal. Make sure connections are secure to terminal block.

A polarity test of the thermocouple and lead wire is easily made with the use of a magnet. On chromel alumel thermocouples and lead wire, the non-magnetic wire is positive (+) and the magnetic wire is negative (-).

- 11) Replace bottom plate.
- 12) Replace thermocouple cover.
- 13) Reconnect furnace to power supply.
- 14) Test operation of furnace.



Warning

Disconnect furnace from power supply before servicing.



Note

Identify or mark wires disconnected to ensure proper placement and connection when reinstalling.

To Replace Insulation

1. Remove thermocouple cover.
2. Set furnace on its top and remove screw and clamp securing thermocouple, then grasp thermocouple and remove by pulling it straight back. Retain porcelain feed-through insulator.
3. Remove back plate.
4. Remove bottom plate.
5. Disconnect the element leads and white insulated wires from terminal block in control section.
6. Disconnect thermocouple leads from terminal block.
7. Remove four screws holding control section to furnace chamber.
8. Remove screws from door switch bracket.
9. Remove the control section from the furnace chamber. Remove plates. Be sure to note how plates are secured together for reassembly.
10. Remove back piece of insulation by opening door and pushing it out gently.
11. Remove bottom piece of insulation by lifting it out.
12. Remove element and hearth plate by pulling it straight back out of the furnace chamber. (Be careful not to damage elements.)
13. Remove side insulating pieces.

14. To remove top insulating piece and hearth collar, position the furnace on its side. Remove both objects from furnace.
15. Reposition furnace on its top. Reinsert new hearth collar and the new top piece of insulation. Insert the new side pieces of insulation last.
16. Reinsert element and hearth plate unit into the chamber, pushing it firmly against the hearth collar. (Be careful not to damage insulation.)
17. Reinsert new bottom piece of insulation over hearth plate. (Element leads and ceramic bushings should be exposed above insulation bottom piece.)
18. Thread the element leads and ceramic bushings through the bottom plate. Bend the leads so they lie close to the refractory plate and the bottom insulation block. (The easiest and safest way to do this is to press the wire flat with a stick or blunt pusher. Do not use a sharp object or nick the wire.) Secure plate to furnace chamber.
19. Reverse steps 1-9 to reassemble furnace.

To Replace Door Switches

1. Turn furnace upside down and remove bottom cover.
2. Disconnect wires from door switches.



Warning

Disconnect furnace from power supply before servicing.

Identify or mark wires disconnected from door switches to ensure proper placement and connection when reinstalling.

3. Remove two screws from door switches and slide door switches out.
4. Install new door switches to bracket. Place furnace in an upright position. Adjust door switches until a click is heard from the switches, when furnace door is approximately 2" from being completely closed. Secure door switches to bracket.
5. Place furnace upside down. Reconnect the wires to new door switches.
6. Replace bottom cover and turn furnace upright.
7. Reconnect furnace to power supply.
8. Test operation of door switches as described in step d.



Warning

Disconnect furnace from power supply before servicing.

To Replace Solid State Relay

1. Turn furnace upside down and remove the bottom cover.
2. Disconnect the wires from the solid state relay. Identify or mark the wires disconnected to ensure proper placement and connection when re-installing.
3. Remove solid state relay from bottom cover. Note placement of solid state relay.



Warning

Disconnect furnace from power supply before servicing.

4. Install new solid state relay and reconnect wires.
5. Replace bottom cover and turn furnace upright.
6. Reconnect furnace to power supply.

To Replace PC Board (Controller)

1. Turn furnace upside down and remove bottom cover.
2. Disconnect wires from PC Board. Identify or mark wires disconnected to ensure proper placement and connection when re-installing.
3. Remove PC Board from bottom cover.
4. Install new PC Board and secure.
5. Reconnect wires identified in step 3 to new PC board.
6. Replace bottom cover and turn furnace upright.
7. Reconnect furnace to power supply.

Wiring Diagram

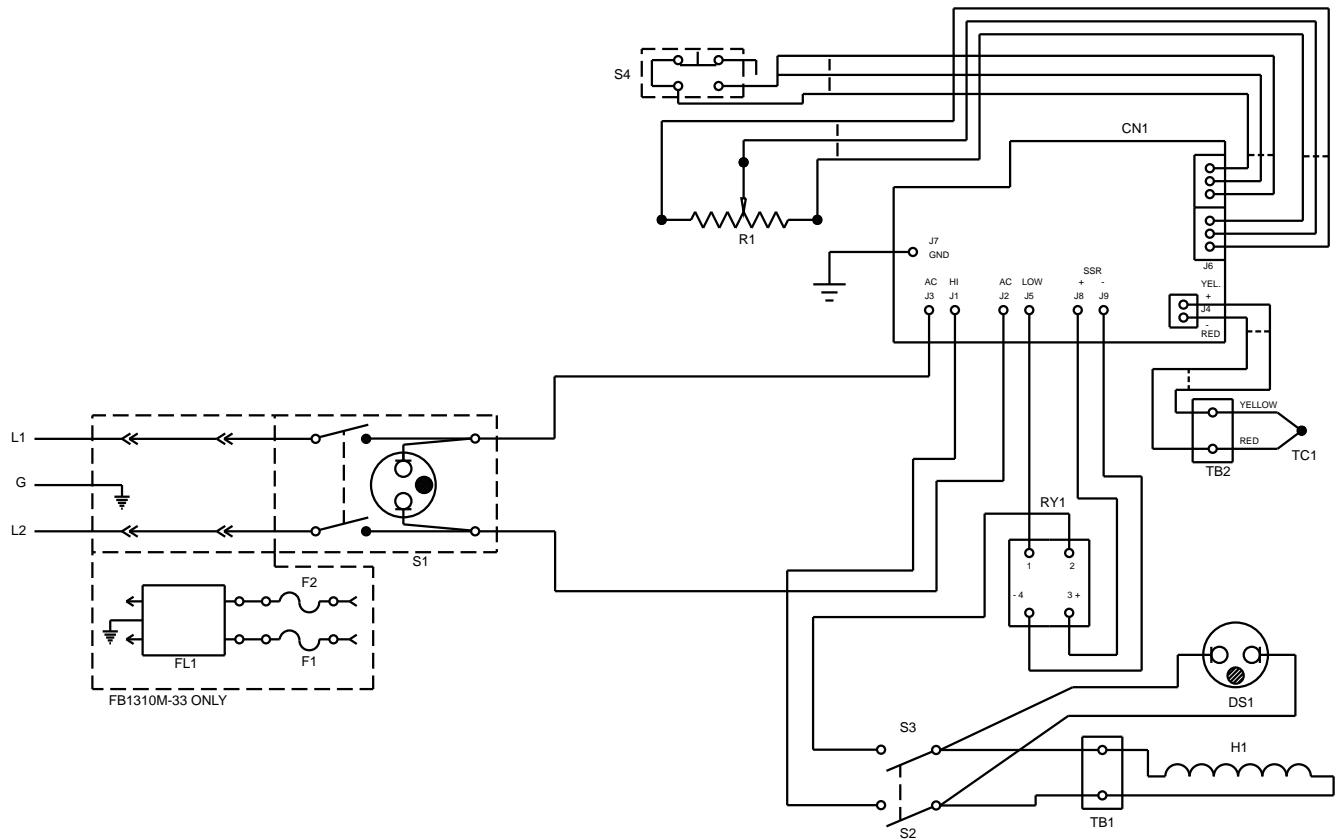

Ref.

No.	Description
CN1	Control
DS1	Pilot Light
F1	Fuse
F2	Fuse
FL1	Capacitor
H1	Heating Element
R1	Resistor, Pot
RY1	Relay, Solid State
S1	Switch, Power
S2	Switch, Door
S3	Switch, Door
S4	Switch, Setpoint
TB1	Terminal Block
TB2	Terminal Block, TC
TC1	Thermocouple

Exploded View

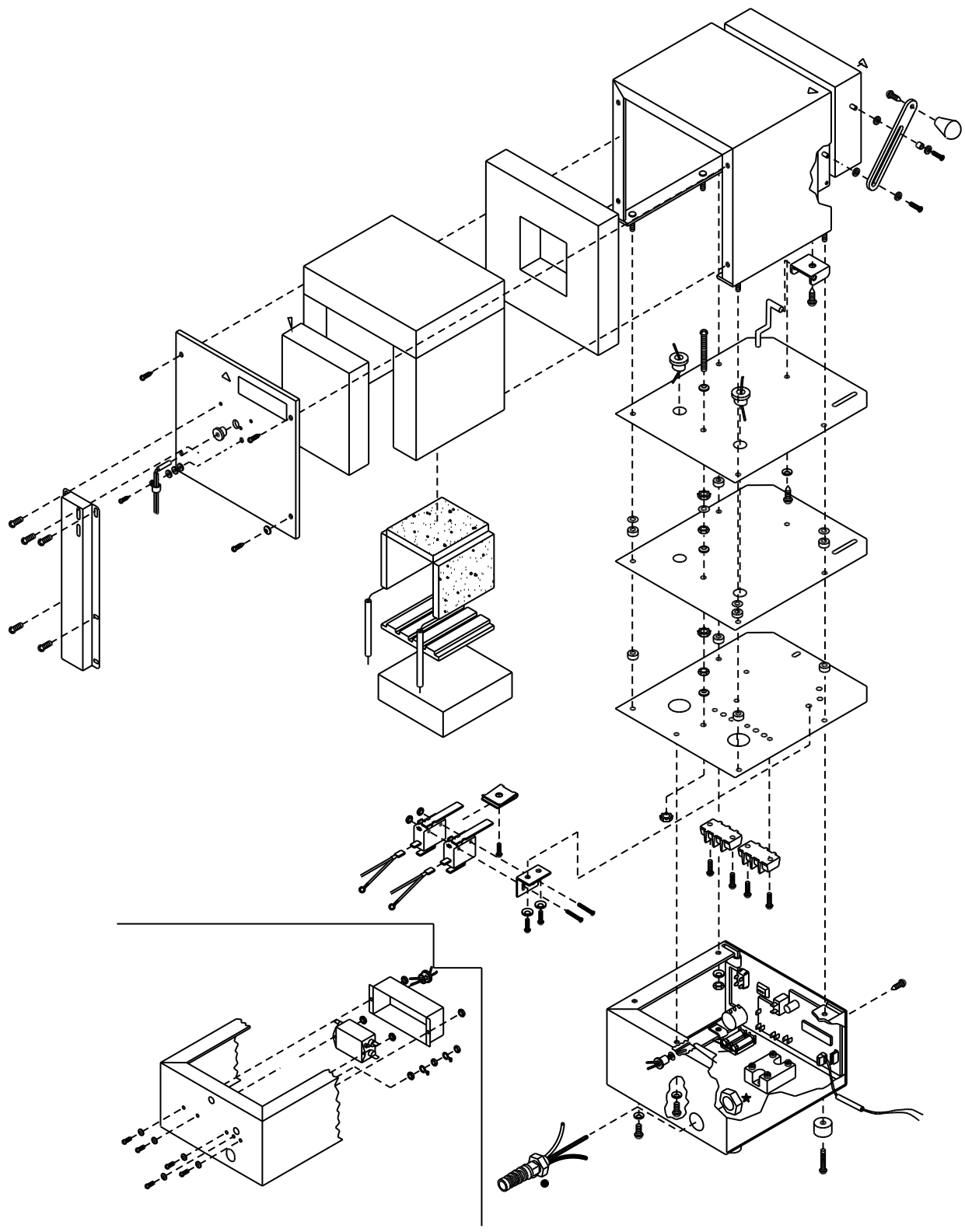

Replacement Parts List

<u>Key#</u>	<u>Description</u>	<u>Quantity Required</u>	<u>Part Number</u>
1	Heating element (100V - FB1314M)	1	EL140X2
1	Heating element (120V - FB1315M)	1	EL44X1
1	Heating element (208V - FB1318M)	1	EL44X3
1	Heating element (240V - FB1310M, -33)	1	EL44X2
1	Heating element (100V - FB1414M)	1	EL186X2
1	Heating element (120V - FB1415M)	1	EL48X1
1	Heating element (208V - FB1418M)	1	EL48X3
1	Heating element (208V - FB1410M, -33)	1	EL48X2
2	Thermocouple (FB1300 all models)	1	TC745X1A
2	Thermocouple (FB1400 all models)	1	TC746X1A
3	Solid State Relay (FB1300, FB1400 all models)	1	RYX54
4	Door Switches (all models)	2	SWX163
5	PC Board (FB1315M, FB1415M)	1	PC745X1A
5	PC Board (FB1310M, -26, FB140M, -26)	1	PC745X2A
5	PC Board (FB1314M, FB1414M)	1	PC745X3A
5	PC Board (FB1318M, FB1418M)	1	PC745X4A
6	Insulation Btm (all FB1300 models)	1	JC44X1
6	Insulation Btm (all FB1400 models)	1	JC48X2
7	Insulation Back (all FB1300 models)	1	JC44X4
7	Insulation Back (all FB1400 models)	1	JC48X1
8	Insulation Top (all FB1300)	1	JC44X3
8	Insulation Top (all FB1400)	1	JC48X3
9	Insulation Hearth Collar (FB1300)	1	HC44X1
9	Insulation Hearth Collar (FB1400)	1	HC48X1
10	Insulation Sides (FB1300)	2	JC460X2
10	Insulation Sides (FB1400)	2	JC48X4
11	Cycle Light (amber) (all 100V & 120V)	1	PLX103
11	Cycle Light (amber) (all 208V & 240V)	1	PLX104
12	Push To Set button	1	SW745X1A
13	Temperature setpoint adjustment (all models)	1	RS745X1A
14	Power Switch (FB1300 100 & 120V models)	1	SWX137
14	Power Switch (FB100 208 & 240V models)	1	SWX138
14	Power Switch (FB1400 100 & 120V models)	1	SWX143
14	Power Switch (FB1400 208 & 240V models)	1	SWX144
15	Door Assembly (FB1300 all models)	1	DR347X1A
15	Door Assembly (FB1400 all models)	1	DR348X1A
16	Element Sleeving (all models)	1	SL745X1
17	Element Sleeving (all FB1300 models)	1	SL59X2
17	Element Sleeving (all FB1400 models)	1	SL745X1
18	Hearth Plate (all FB1300 models)	1	PH44X1
18	Hearth Plate (all FB1400 models)	1	PH48X1
19	Filter (all -33 models)	1	CAX98
20	Fuse Holder (all -33 models)	1	FZX26
21	Fuse 10 amp .25 + 1.25 - (Buss™ Type ABC, all -33 models)	2	FZX30

Ordering Procedures

Please refer to the Specification Plate for the complete model number, serial number, and series number when requesting service, replacement parts or in any correspondence concerning this unit.

All parts listed herein may be ordered from the Barnstead|Thermolyne dealer from whom you purchased this unit or can be obtained promptly from the factory. When service or replacement parts are needed we ask that you check first with your dealer. If the dealer cannot handle your request, then contact our Customer Service Department at 319-556-2241 or 800-553-0039.

Prior to returning any materials to Barnstead|Thermolyne Corp., please contact our Customer Service Department for a "Return Goods Authorization" number (RGA). Material returned without a RGA number will be refused.

One Year Limited Warranty

Barnstead|Thermolyne Corporation warrants that if a product manufactured by **Barnstead|Thermolyne** and sold by it within the continental United States or Canada proves to be defective in material or construction, it will provide you, without charge, for a period of ninety (90) days, the labor, and a period of one (1) year, the parts, necessary to remedy any such defect. Outside the continental United States and Canada, the warranty provides, for one (1) year, the parts necessary to remedy any such defect. The warranty period shall commence either six (6) months following the date the product is sold by **Barnstead|Thermolyne** or on the date it is purchased by the original retail consumer, whichever date occurs first.

All warranty inspections and repairs must be performed by and parts obtained from an authorized **Barnstead|Thermolyne** dealer or **Barnstead|Thermolyne** (at its own discretion). Heating elements, however, because of their susceptibility to overheating and contamination, must be returned to our factory, and if, upon inspection, it is concluded that failure is not due to excessive high temperature or contamination, warranty replacement will be provided by **Barnstead|Thermolyne**. The name of the authorized **Barnstead|Thermolyne** dealer nearest you may be obtained by calling 1-800-446-6060 (319-556-2241) or writing to:

Barnstead|Thermolyne
P.O. Box 797
2555 Kerper Boulevard
Dubuque, IA 52004-0797
USA
FAX: (319) 589-0516
E-MAIL ADDRESS: mkt@barnstead.com

Barnstead|Thermolyne's sole obligation with respect to its product shall be to repair or (at its own discretion) replace the product. Under no circumstances shall it be liable for incidental or consequential damage.

THE WARRANTY STATED HEREIN IS THE SOLE WARRANTY APPLICABLE TO **Barnstead|Thermolyne** PRODUCTS. **Barnstead|Thermolyne** EXPRESSLY DISCLAIMS ANY AND ALL OTHER WARRANTIES, EXPRESSED OR IMPLIED, INCLUDING WARRANTIES OF MERCHANTABILITY OR FITNESS FOR USE.

Barnstead|Thermolyne
2555 Kerper Blvd. A Sybron laboratory products company
P.O. Box 797
Dubuque, IA 52004-2241
Phone: 319-556-2241 800-553-0039
Fax: 319-589-0516
E-Mail Address: mkt@barnstead.com

