

Precise fully automatic core loss measurement at high frequency

De facto standard equipment for research & development of soft magnetic materials.



DC bias test system

Precise automatic core loss measurement in higher frequency

Precise and accurate core loss measurement

Iwatsu's B-H analyzers which hiring CROSS-POWER method (IEC62044-3) enable precise and highly accurate measurement embedded minimized phase error integration on frequency spectrum with current detecting resistors and compensation on detecting circuit with full compensation on amplitude and phase characteristics. Third generation models from year 1984 are available now to contribute leading-edge development on future power management.

SY-810 Remote control software



IE-1125B Power amplifier

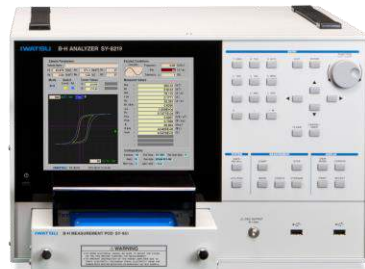

SY-8218 B-H analyzer



SY-320A Temperature scanner system

Feature

- Wide band frequency range from 10Hz to 10MHz (SY-8218)
- Voltage : $\pm 140V$, max. / Current : $\pm 5.2A$, max. DC to 3MHz High power amplifier (IE-1125B)
- 41pcs., max. specimen for temperature range of $-30^{\circ}C$ to $150^{\circ}C$ automatic scanner system (SY-321A)
- 36mm(L),min. 35mm(W),max. single sheet test (SY-956)
- DC30A, max. DC-bias superposing test (SY-960/961/962)

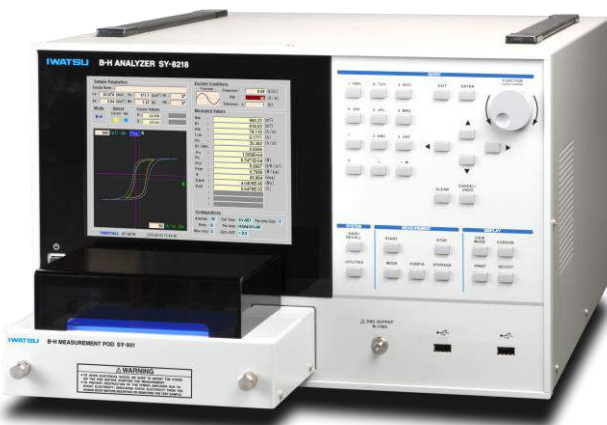

B-H analyzer



Single sheet test system SY-956



Temperature scanner system SY-320A

Power amplifier



HSA4101-IW



HSA4014-IW





IE-1125B



DC-bias test system

Various types of soft magnetic material property test

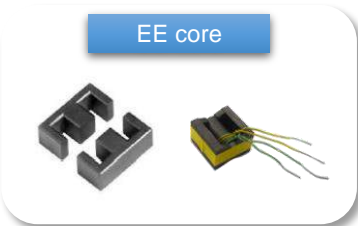
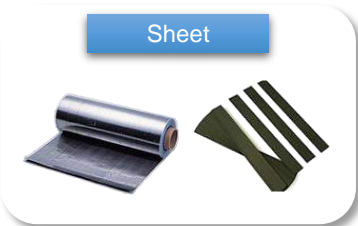
Soft magnetic materials Ferrite Permalloy Amorphous Silicon steel sheet Dust core	Types of shape Toroid EE core EI core Sheet Powder	Toroidal 	Powder 
		EE core 	Sheet 

Full automatic test

Sample parameters (Effective magnetic length, Effective cross section, number of turns of windings, etc.) and test conditions (Frequency, Maximum field strength: Hm, Maximum flux density: Bm, Maximum induced voltage: V2m, Maximum exciting current: I1m) inputs enable obtaining BH hysteresis curve and magnetic properties in value automatically.

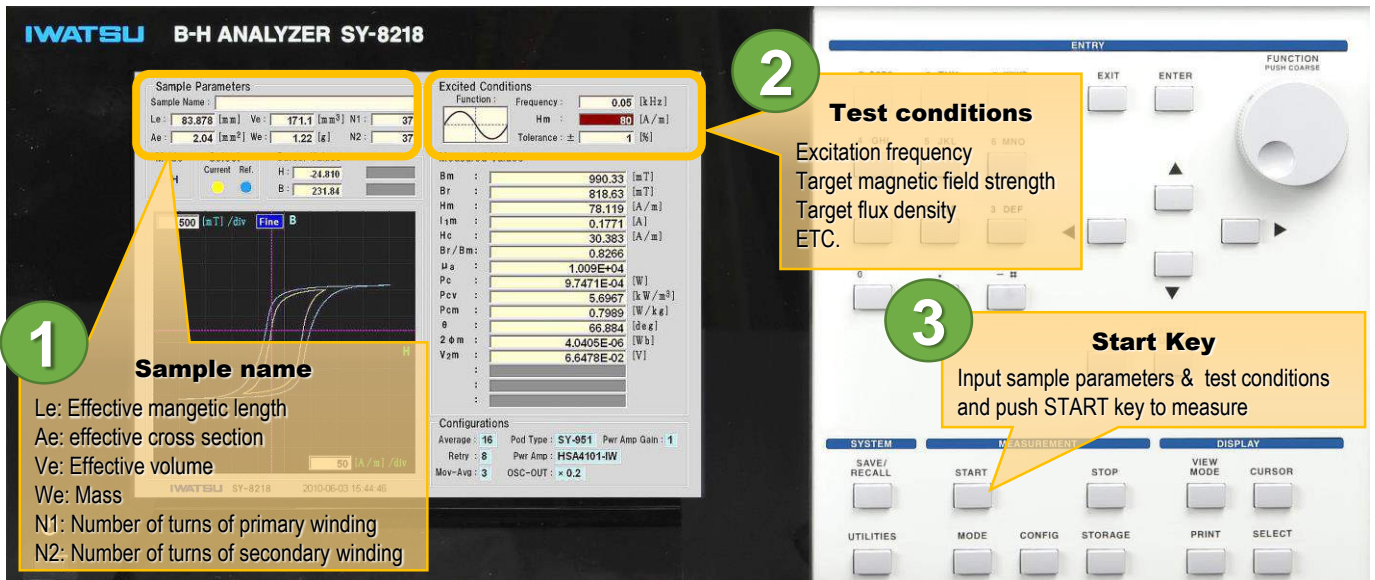

1 Sample name
 Le: Effective magnetic length
 Ae: effective cross section
 Ve: Effective volume
 We: Mass
 N1: Number of turns of primary winding
 N2: Number of turns of secondary winding

2 Test conditions
 Excitation frequency
 Target magnetic field strength
 Target flux density
 ETC.

3 Start Key
 Input sample parameters & test conditions and push START key to measure

Full automatic test with options

Temperature scanner system, Single sheet test system and DC biasing system are able to control with the SY-810 Remote control software.

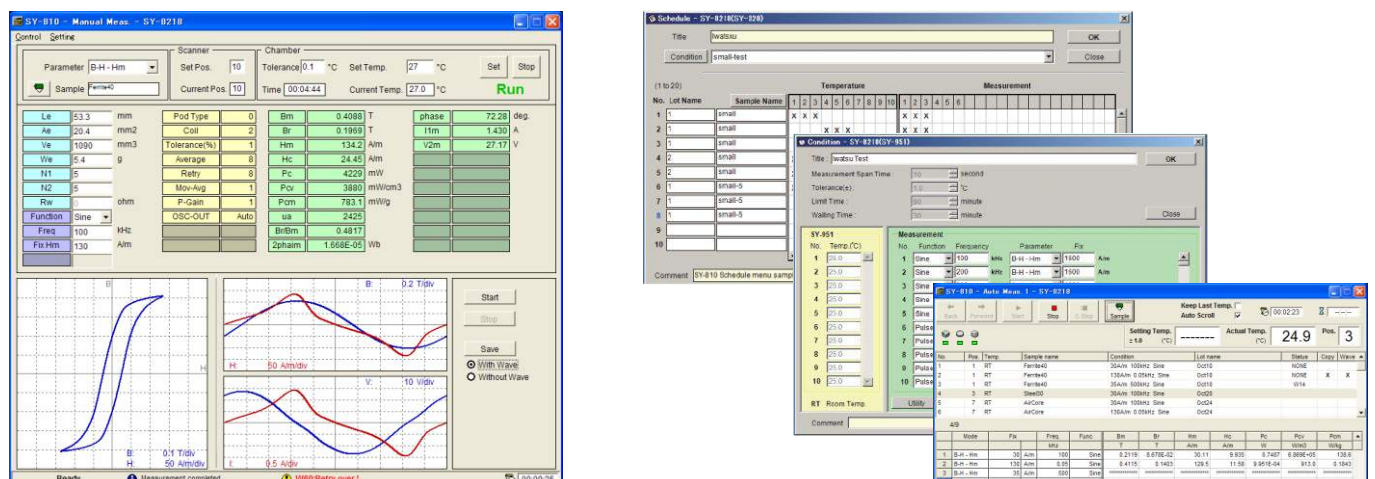

Control Settings

Parameter: B-H-14m	Set Pos: 10	Tolerance: 0.1 °C	Set Temp: 27 °C	Set	Stop
Sample: Ferrite	Current Pos: 10	Time: 00:04.44	Current Temp: 27.0 °C	Run	

Schedule - SY-810 (MSY-810)

No.	Lot Name	Sample Name	1	2	3	4	5	6	7	8	9	10
1		small	X	X	X	X	X	X	X	X	X	X
2		small										
3		small										
4		small										
5		small-5										
6		small-5										
7		small-5										
8		small-5										
9		small-5										
10		small-5										

Measurement Data

No.	Temp (°C)	Function	Frequency	Parameter	Unit
1	27.0	Small	1500 kHz	B-H-14m	1500 A/m
2	27.0	Small	1500 kHz	B-H-14m	1500 A/m
3	27.0	Small	1500 kHz	B-H-14m	1500 A/m
4	27.0	Small	1500 kHz	B-H-14m	1500 A/m
5	27.0	Small	1500 kHz	B-H-14m	1500 A/m
6	27.0	Small	1500 kHz	B-H-14m	1500 A/m
7	27.0	Small	1500 kHz	B-H-14m	1500 A/m
8	27.0	Small	1500 kHz	B-H-14m	1500 A/m
9	27.0	Small	1500 kHz	B-H-14m	1500 A/m
10	27.0	Small	1500 kHz	B-H-14m	1500 A/m

Precise test in higher frequency

B-H analyzer

SY-8218 10Hz-10MHz

SY-8219 10Hz- 1MHz

- Test freq. : 10Hz to 10MHz (SY-8218) / 10Hz to 1MHz (SY-8219)
- Applying signal waveform : Sinusoidal or Pulse (10Hz to 1MHz)
- Input current : ±6A, maximum
- Input voltage : ±200V, maximum
- Excitation method : Automatic excitation
(at fixed Hm, Bm I1m or V2m)

Residual flux can be eliminated by degaussing with applying AC magnetic field

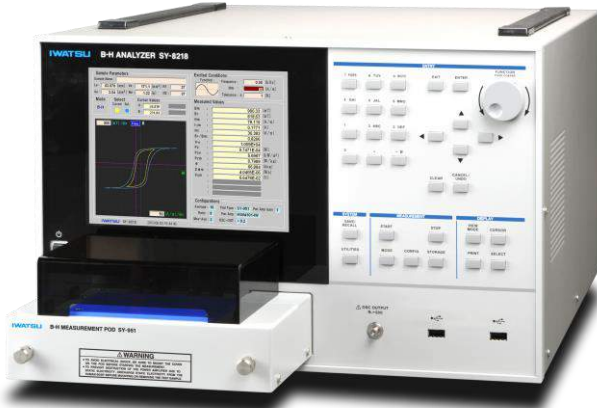

SY-8218 BH analyzer mainframe

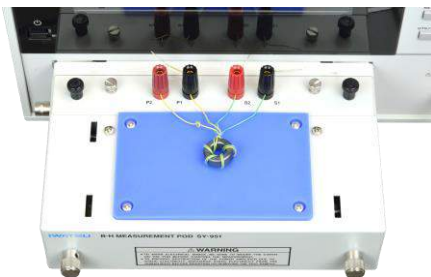

Measurement POD image without POD cover

Measurement method	CROSS-POWER method (conformance to IEC62044-3)
Measurement Item (Symbol)	Max. Magnetic flux density(Bm), Residual magnetic flux density(Br), Max.Magnetic field strength(Hm), Coersive force(Hc), Rectangular ratio(Br/Bm), Relative amplitude permeability(μ_a), Core loss(Pc,Pcv,Pcm), Primary excitation current(I1m), Secondary induced voltage(V2m), Phase(θ), Total magnetic flux linkage(2 ϕ_m), Apparent power(VA), Impedance permeability(μ_z), Complex permeability(μ', μ''), Loss coefficient(tan δ), Inductance(L), Resistance(R), Impedance(Z), Quality factor(Q), Total harmonic distortion(THD)
Waveform display	B-H curve, Excitation current, Induced voltage, Magnetic field, Magnetic flux density
Test frequency	Sinusoidal 10Hz~10MHz (SY-8218) 10Hz~1MHz (SY-8219)
	Square 10Hz~1MHz (Duty50)
Magnetic field signal detection	Voltage drop at Non-inductive resister, Maximum current at ±6A
Magnetic flux density signal detection	Voltage detection at induced voltage detection coil, Maximum signal detection voltage at ±200V
Digitizer	16bits (8192points/cycle)
Sample connection method	2 or 1 coil (winding) method selectable
Display	8.4" TFT-LCD SVGA 800×600pixels
Power	AC100V to AC240V, 50/60Hz, Approx. 130VA (MAX.)
Weight	Approx. 12.5kg
Dimensions	420W×266H×480D(mm)
External memory	USB port for data storage
Accessories	Reference sample, POD cover, AC coupler module, Power amplifier cable (BNC-BNC), OSC cable (SMA-BNC), Power cable, Operation manual(CD-ROM), Users guide

Power amplifier

Wide band and High power

Best fit with B-H analyzer

HSA4101-IW 10MHz, 1A, 71V

HSA4014-IW 1MHz, 5.6A, 75V

IE-1125B 3MHz, 5.2A, 140V



HSA4101-IW



HSA4014-IW



IE-1125B

	HSA4101-IW	HSA4014-IW	IE-1125B
Frequency	DC~10MHz	DC~1MHz	DC~3MHz
Output current (peak)	±1A, max.	±5.6A, max.	±5.2A, max.
Output voltage (peak)	±71V, max.	±75V, max.	±140V, max.
Output power	50VA	200VA	350VA
Input power			
Frequency	50/60Hz	50/60Hz	50/60Hz
Voltage Range	AC100V to 115V AC200V to 230V	AC90V to 110V factory option: 120V/200V/220V/ 240V	AC 90V to 250V
Power consumption	700VA, max. (400W)	900VA, max. (700W)	2kVA, max.
Weight & Dimensions	Approx. 7.8kg 220W×177H ×450D(mm)	Approx. 18kg 290W×177H ×450D(mm)	Approx. 29kg 440W×238H ×600D(mm)

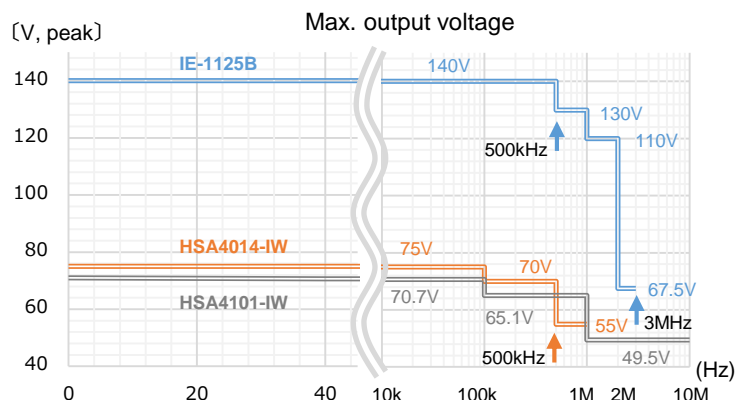
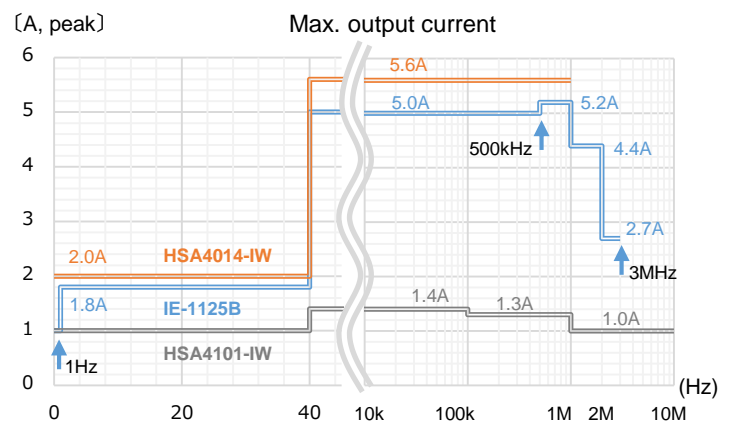

※SY-911 connection cable option has to be required for IE-1125B.

Temperature range : -30°C to 150°C, Sample 41pcs, max.

Temperature scanner system
 SY-320A sample 20pcs., max.
 SY-321A sample 41pcs., max.

- Test freq. : 10Hz~5MHz (with SY-8218 mainframe)
 : 10Hz~1MHz (with SY-8219 mainframe)
- Input current : ±6A, max.
- Input Voltage : ±200V, max.
- Temp. range : -30°C to 150°C



	SY-320A	SY-321A
Scanner chamber unit		
Input voltage	AC100V 50/60Hz	
Input current	12.5A, max.	21.0A, max.
Temperature range	-30°C to 150°C	
Scanner mechanism unit		
Input power	AC100V to 120V, 50/60Hz	
Power consumption	28VA	
Test frequency range	10Hz to 5MHz with SY-8218 10Hz to 1MHz with SY-8219	
Samples	20pcs., max.	41pcs., max.
Input current	±6A, max.	
Input voltage	±200V, max.	
Weight	85kg	135kg
Outer Dimensions	543W×695L×620H (mm)	640W×920L×660H (mm)
Accessories	Reference sample, Chamber cable(SY901), Turn table*, GPIB cable(1meter), Power cable, Operation manual *SY-510(SY-320A) or SY-511(SY-321A)	

Remote control system configurations

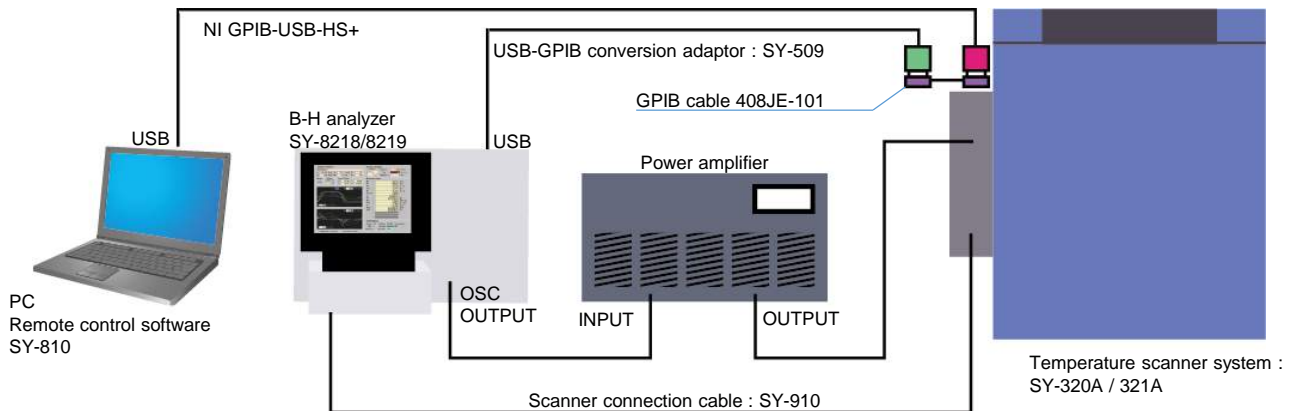

REMOTE CONTROL SOFTWARE : SY-810

Temp. Freq. Target magnetic field strength

Example of test result

Spare parts for temperature scanner system

Turntable (for setting samples on scanner mechanism)
SY-510 (for SY-320A)
SY-511 (for SY-321A)



SY-511

Spare connection pin set
SY-512 (for SY-320A/321A)



SY-512

Full automatic accurate test for single sheet shape samples such as Silicon-steel sheets, etc.

Single Sheet Test system
SY-956

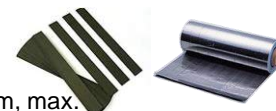

- Test frequency: 10Hz to 20kHz
- Applicable magnetic field strength : 10,000A/m, max.
- Sample dimensions : Single sheet samples at ; 36mm(L), min. / 35mm(W), max. and 3mm(t), max.
- Introducing vertical single yoke current excitation type single sheet magnetic property characteristics test method
- Yoke compensation function cancelling loss and other affection in Yoke (patent pending)
- Constant pressing force on specimen (selectable from 16 kinds of force settings)

B coils (as standard)

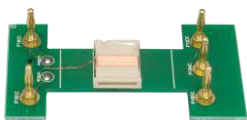

B coil 01

Sample size
Thickness : 1mm, max.
Width : 10mm, max.
Number of turns : 35

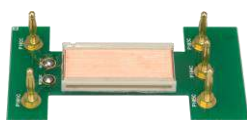

B coil 02

Sample size
Thickness : 1mm, max.
Width : 30mm, max.
Number of turns : 100

Measurement method	vertical single yoke current excitation type single sheet magnetic property characteristics test method (IEC 60404-3 compatible)(Yoke compensation : available)
Applicable magnetic field strength	Approx. 10,000A/m (Max.) with excitation level at 5A
Test frequency	Sinusoidal 10Hz to 20kHz
Sample dimension	35mm(W),max., 36mm(L), min. 3mm(thickness),max.
Detection current	±6A, max.
Detection voltage	±200V, max.
Power	AC100V to AC240V, 50Hz/60Hz, Approx. 27VA(Max.)
Performance guarantee temperature	18°C to 28°C
Dimension	330W×200H×320D(mm)
Weight	Approx. 8.5kg
Accessories	Single sheet test system connection cable SY-957, B coil (2kinds), Connection terminal screw, Pincer, Blowing blush, Accessory case, Power cable, Operation manual



Hint :

Steel sheet will show different magnetic properties between the different shapes even exactly the same material. It is important to test magnetic property as a single sheet prior to machining.



Example of Permalloy

Hc : Round=Oval
Br : Round<Oval
Bm : Round<Oval
Core loss : Round<Oval

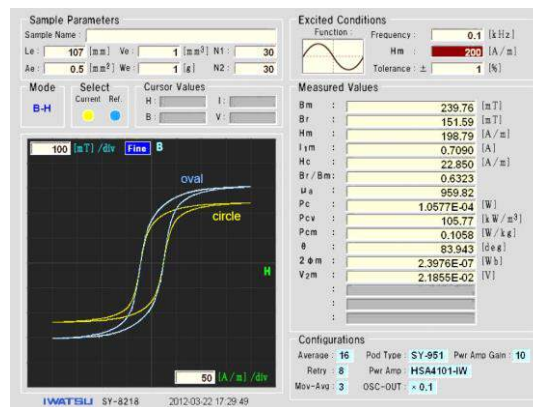

LF AC coupler SY-514

AC coupler at fLc=300Hz(-3dB) to use in lower frequency than AC coupler SY-503 which provided as a standard accessory with BH analyzer mainframe.



fLc(cut-off freq.) : Approx. 300Hz
Input voltage : ±200V, max.
Input current : ±6A, max.
Connection cable : BNC cable(0.6m)

10kHz AC coupler SY-504 (standard accessory for B-H Analyzers)



Blank toroidal core SY-513

Blank toroidal shape casing for powder material or layered thin material donuts shape, etc.

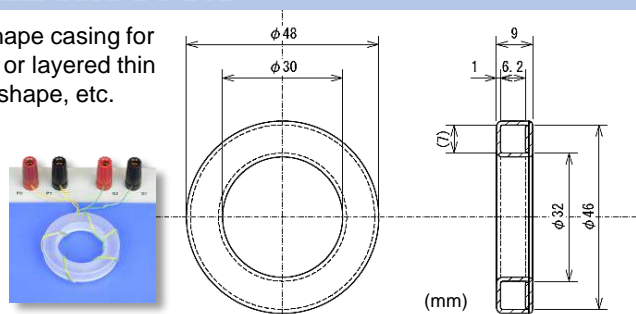

DC biasing source SY-931

DC current : 10A, max.
Operation freq. : 1MHz, max.



Automatic test on power inductor properties with DC biasing

DC-bias test system SY-960/961/962



SMD Power inductor



Toroidal coil inductor

- DC bias current : 30A, max
- AC Ripple current : ±6A, max
- Test frequency(Sinusoidal) : 10kHz to 3MHz
- Test frequency(Pulse) : 10kHz to 1MHz (Duty10%-90%)

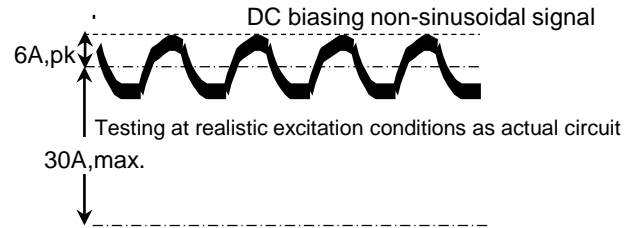

Testing at realistic excitation conditions as actual circuit
Pulse(Triangular signal waveform in current at specimen, called QUASI-CHOPPER), or Sinusoidal test with DC biasing

Test example on chip inductor (Chopper excitation)

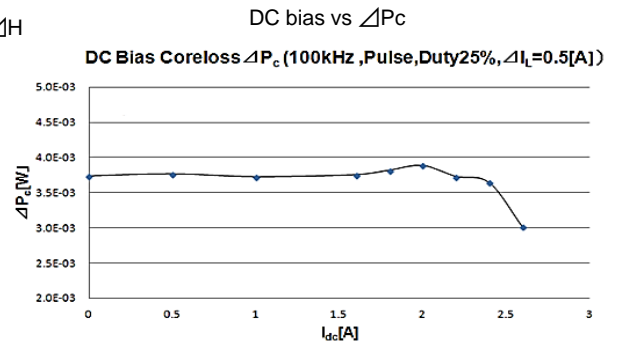
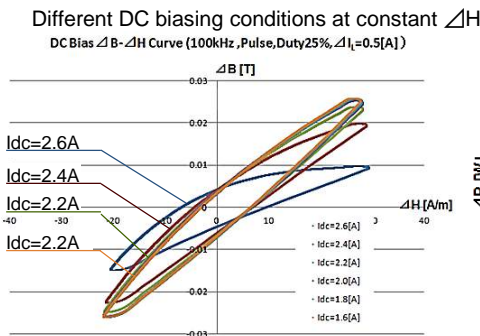
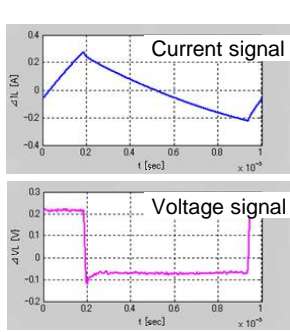

Hint:

In actual operation, both AC magnetic field and DC magnetic field may be applied at the same time usually. Magnetic property test with changing DC biasing level is considered important.

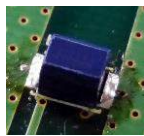

Ferrite(SMA)
L=1.0μH

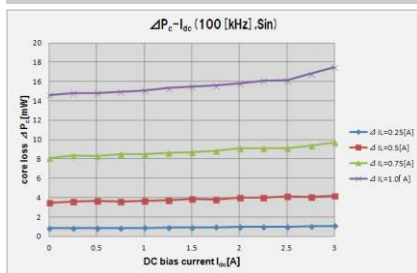
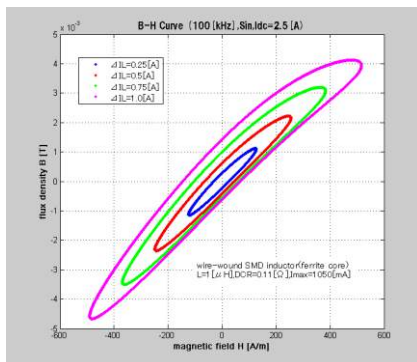

Fe-Based amorphous core
L=311μH

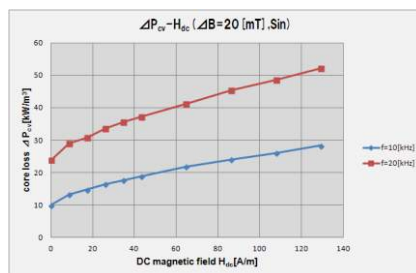
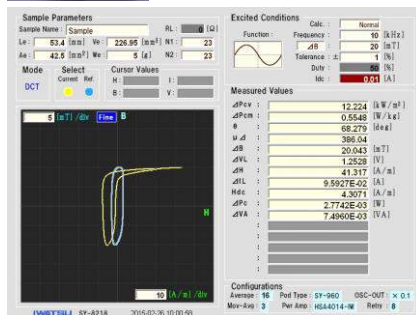

Iron powder core
L=8.4μH

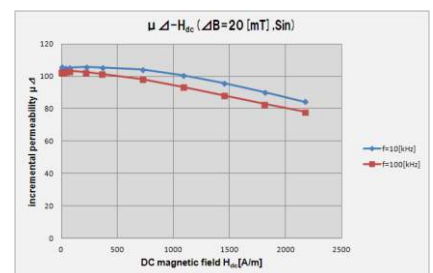
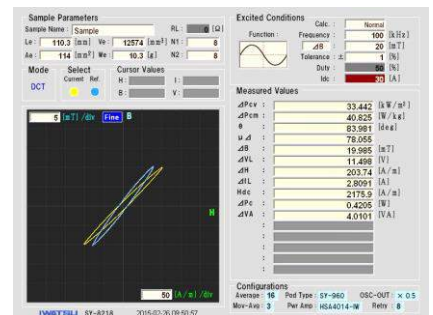

Automatic test can be performed such as property test vs frequency, etc.

Remote control software SY-810

- Temperature conditions up to 20kinds, Excitation conditions up to 40kinds for each DUT(device under test) are available. This means 20x40(=800)kinds of conditions can be programmed for each sample of DUT.
- Pulse excitation can be controlled with BH analyzer
- Hard copy of displayed results (JPEG, PNG) and signal waveform data at xxx.csv basis can be extracted to PC memory.

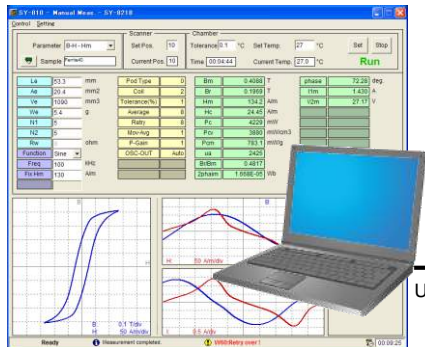

Display example of remote control software SY-810

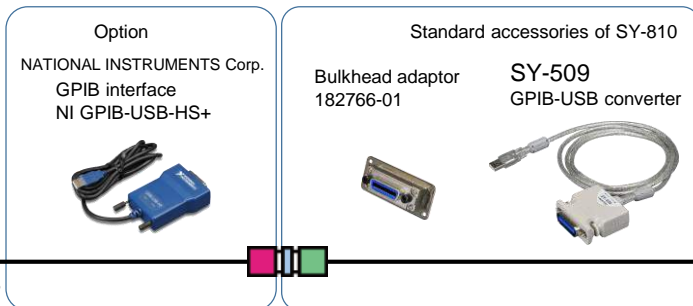

Contents of SY-810 : CD (software and operation manual at PDF), GP-IB converter SY-509, Bulkhead adaptor 182766-01 and software license agreement

PC operation environment

OS: Windows Vista SP2, Windows7 32bit/64bit, Windows8 32bit/64bit

.NET Framework(packaged), CPU Pentium133M or above, Memory at 64Mbyte or more, Display resolution at 1024x768 or above, USB port x1

※Contact our sales for the most recommended system configurations.

※NI GPIB-USB-HS+ (NATIONAL INSTRUMENTS Corp.) is required for PC interface with SY-8218/SY-8219. PC is not included with this system and supplied by customer.

Continuous test function SY-811

Time-tendency property test can be performed at continuous excitation.

- Test timeframe at 99,999minutes(Approx. 70days), max. 60second/test
- 2 kinds of properties can be monitored on display and extracted to memory.
- Measurement item can be changed during test.
- Comparison between Reference and test result on the same display.
- Test data at CSV and display hardcopy at JPG/PNG are available.

※Option for BH analyzer

※Implementation of SY-811 on BH analyzers(SY-8218/SY-8219) at the customer end will be returned to our factory for installation and inspection.

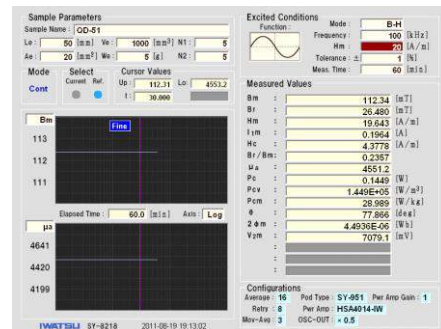

Equipment wagon

Equipment wagon

MT-600L

Table can be modified of it's height.

Major items :

- Slide pull-out table
- Pull out for accessories
- 4 wheel casters with lock function
- Equipment tighten belt

Mountable weight : 100kg, max.

Height : Approx. 850mm

Table : 590W×775D(mm) fixed

Weight : Approx. 36kg

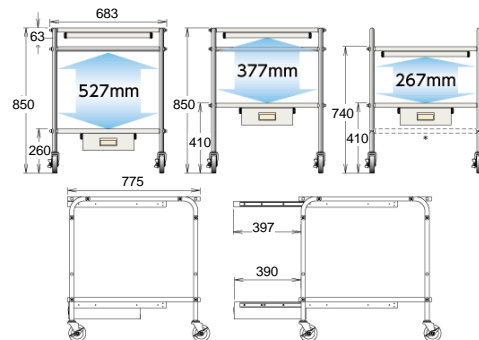

※Supplied as each piece and assembled by customer

※The products shown in this catalogue are current models at the date of publication. Design and specification are subject to change without notice for improvement.

※All enterprises including National instruments and Microsoft, etc. and product names mentioned are trademarks or registered trademarks of the respective owners.

※ Some of the products are Regulated Products subject to the Foreign Exchange and Foreign Trade Control Law of Japan. Export should not be allowed without appropriate governmental authorization. Please ask our sales office whether the product concerned is a Regulated Product(s).

IWATSU <http://www.iti.iwatsu.co.jp/>
IWATSU TEST INSTRUMENTS CORP.

Sales Dept.
 International Sales Section
 7-41, 1-Chome Kugayama, Suginami-Ku,
 Tokyo,168-8511 Japan
 Tel: +81-3-5370-5483 Fax: +81-3-5370-5492

8511-3111-0
 C.S(OK)1503-845-1-00
 BH14055E-108