



Advanced Test Equipment Rentals
www.atecorp.com 800-404-ATEC (2832)

User Manual

p

ST2400A
2.4 Gb/s SDH Test Set

071-0241-04

This document supports firmware version 5.4 and above.

Copyright © 1999 Tektronix, Inc. All rights reserved. Licensed software products are owned by Tektronix or its suppliers and are protected by United States copyright laws and international treaty provisions.

Use, duplication, or disclosure by the Government is subject to restrictions as set forth in subparagraph (c)(1)(ii) of the Rights in Technical Data and Computer Software clause at DFARS 252.227-7013, or subparagraphs (c)(1) and (2) of the Commercial Computer Software - Restricted Rights clause at FAR 52.227-19, as applicable.

Tektronix products are covered by U.S. and foreign patents, issued and pending. Information in this publication supersedes that in all previously published material. Specifications and price change privileges reserved.

Tektronix, Inc., P.O. Box 1000, Wilsonville, OR 97070-1000

TEKTRONIX and TEK are registered trademarks of Tektronix, Inc.

WARRANTY

Tektronix warrants that this product will be free from defects in materials and workmanship for a period of three (3) years from the date of shipment. If any such product proves defective during this warranty period, Tektronix, at its option, either will repair the defective product without charge for parts and labor, or will provide a replacement in exchange for the defective product.

In order to obtain service under this warranty, Customer must notify Tektronix of the defect before the expiration of the warranty period and make suitable arrangements for the performance of service. Customer shall be responsible for packaging and shipping the defective product to the service center designated by Tektronix, with shipping charges prepaid. Tektronix shall pay for the return of the product to Customer if the shipment is to a location within the country in which Tektronix service center is located. Customer shall be responsible for paying all shipping charges, duties, taxes, and any other charges for products returned to any other locations.

This warranty shall not apply to any defect, failure or damage caused by improper use or improper or inadequate maintenance and care. Tektronix shall not be obligated to furnish service under warranty a) to repair damage resulting from attempts by personnel other than Tektronix representatives to install, repair or service the product; b) to repair damage resulting from improper user or connection to incompatible equipment; or c) to service a product that has been modified or integrated with other products when the effect of such modification or integration increases the time or difficulty of servicing the product.

THIS WARRANTY IS GIVEN BY TEKTRONIX WITH RESPECT TO THIS PRODUCT IN LIEU OF ANY OTHER WARRANTIES, EXPRESSED OR IMPLIED. TEKTRONIX AND ITS VENDORS DISCLAIM ANY IMPLIED WARRANTIES OF MERCHANTABILITY OR FITNESS FOR A PARTICULAR PURPOSE. TEKTRONIX' RESPONSIBILITY TO REPAIR OR REPLACE DEFECTIVE PRODUCTS IS THE SOLE AND EXCLUSIVE REMEDY PROVIDED TO THE CUSTOMER FOR BREACH OF THIS WARRANTY. TEKTRONIX AND ITS VENDORS WILL NOT BE LIABLE FOR ANY INDIRECT, SPECIAL, INCIDENTAL, OR CONSEQUENTIAL DAMAGES IRRESPECTIVE OF WHETHER TEKTRONIX OR THE VENDOR HAS ADVANCE NOTICE OF THE POSSIBILITY OF SUCH DAMAGES.

How to Reach Customer Service

Tektronix provides high quality Technical Support on applications, operation, measurement specifications, hardware, and software by expert application engineers. If you have any questions regarding the operation, maintenance, repair, or application of your Tektronix equipment, contact your local sales and service office.

For more information on Tektronix equipment and support services, refer to the Tektronix web-site at www.tektronix.com or call 1-800-Tek-Wide.

Table Of Contents

General Safety Summary	ix
Preface.....	xii
Getting Started	
Product Description	1-1
Ordering Information.....	1-2
Overview, SDH.....	1-3
Features and Capabilities	1-4
Bellcore CLEI and CPR Product Codes	1-5
Accessories	1-6
Standard	1-6
Optional.....	1-6
First-Time Operation.....	1-8
Functional Overview	
Front Panel Controls, Indicators and Connectors	2-1
Display, Display Controls and Indicators.....	2-2
Setup Menu System.....	2-2
Examples of SDH Setup Main Menus	2-3
Transmitter Description	2-4
Transmitter Connectors	2-4
Transmitter Status Indicators	2-5
Mode Key.....	2-5
Tributary and Input Select Keys, Transmitter.....	2-5
OVHD Key, Transmitter.....	2-6
Alarm Key, Transmitter.....	2-6
Error Key, Transmitter.....	2-6
Receiver Description.....	2-7
Receiver Connectors	2-7
Receiver Status Indicators	2-8
View History Key.....	2-9
Drop Select Key, Receiver.....	2-9
Tributary Select Key, Receiver.....	2-9
OVHD Key, Receiver.....	2-9
Measurement Controls & Indicators	2-10
Front Panel Connections	2-11
Remote Indicators	2-12
Rear Panel Description	2-12
Laser Lockout, Remote Interlock.....	2-13
SYNC Output.....	2-13
BITS Ext Ref.....	2-13
Rear Panel Connectors.....	2-14
Applications and Use.....	2-15
Passive Monitoring	2-15
Active Analysis	2-16
Active Through Mode Analysis	2-17

Example - STM-16c/ OC-48c Application.....	2-17
Reference	
Setup Menus	3-1
Laser Menus.....	3-4
Laser Modules	3-5
TX Event Trigger Output Menu.....	3-6
View Angle Menu.....	3-7
Store/Recall Setup Menu.....	3-7
Report/ Test Time Menu	3-7
Auxiliary Setup Menu	3-8
Power Fail Recovery	3-9
General Menus & Displays.....	3-10
Menu & Measurement Refinements	3-10
Transmitter or Receiver Configurations.....	3-12
Error Log Display.....	3-13
Transmitter Menus & Displays	3-14
TX Source Mode	3-14
External Clock Synchronization	3-16
PRBS Mapping.....	3-17
Input Select, Transmitter.....	3-18
Tributary Select, Transmitter	3-18
Illegal Mode.....	3-19
Alarm Generation Menus - SDH.....	3-20
Overhead Menus (SDH), Transmitter.....	3-22
Ability to Edit Multi-byte J0 Trace	3-23
J0, J1 Trace Capture & Display.....	3-26
Ability to Edit M1 Byte.....	3-28
Error Generation Menus (SDH).....	3-29
B2 or B3 Error Inject	3-31
Inject Random BER on one Selectable Channel	3-32
Receiver Menus & Displays	3-33
Error Measurements, Receiver.....	3-33
Error Measurement Details	3-40
G.826 and M.2101 Measurements in SDH Mode.....	3-40
Overhead Displays, Receiver.....	3-42
ASCII Synchronization Messages - S1 byte.....	3-43
Automatic Protection Switching (APS).....	3-44
Receiver Tributary Select	3-45
Receiver Tributary - RX Channel Selection (SDH).....	3-46
Pointers Information from Receiver Tributary Key (SDH)	3-46
Receiver Drop Select.....	3-47
Appendices	
Specifications, SDH.....	A-1
Incoming Inspection Test.....	B-1
Factory Defaults	C-1
SONET for Reference.....	F-1
SDH Glossary and ITU-T Standards	G-1

Index.....	I-1
-------------------	------------

General Safety Summary

Review the following safety precautions to avoid injury and prevent damage to this product or any equipment connected to it. To avoid potential hazards, use this product only as specified.

To avoid potential hazards, use this product only as specified.

Only qualified personnel should perform service procedures.

While using this product, you may need to access other parts of the system. Read the *General Safety Summary* in other system manuals for warnings and cautions related to operating the system.

Injury Precautions

Use Proper Power Cord

To avoid fire hazard, use only the power cord specified for this product.

Avoid Electric Overload

To avoid electric shock or fire hazard, do not apply a voltage to a terminal that is outside the range specified for that terminal.

Ground the product

This product is grounded through the grounding conductor of the power cord. To avoid electric shock, the grounding conductor must be connected to earth ground. Before making connections to the input or output terminals of the product, ensure that the product is properly grounded.

Do not operate without covers

To avoid electric shock or fire hazard, do not operate this product with covers or panels removed.

Use Proper Fuse

To avoid fire hazard, use only the fuse type and rating specified for this product.

Do not operate in Wet/Damp Conditions

To avoid electric shock, do not operate this product in wet or damp conditions.

Do not operate in Explosive Atmosphere

To avoid injury or fire hazard, do not operate this product in an explosive atmosphere.

Wear Eye Protection

To avoid eye injury, wear eye protections if there is a possibility of exposure to high-intensity rays.

Product Damage Precautions

CAUTION!

Signal levels greater than -10dBm (negative 10dBm) may damage the Optical Input devices. Always pad the input level to less than -10dBm .

Always use 15 dB of attenuation when connecting the ST2400A Transmitter output to its receiver input. Failure to do so will damage the optical detector.

Use Proper Power Source

Do not operate this product from a power source that applies more than the voltage specified.

Provide Proper Ventilation

To prevent product overheating, provide proper ventilation.



Do not operate with suspected failures

If you suspect there is damage to this product, have it inspected by qualified service personnel.

Safety Terms and Symbols

Terms in this manual

These terms may appear in this manual:

Icon	Label	Meaning
	WARNING!	Warning statements identify conditions or practices that could result in injury or loss of life.
	CAUTION!	Caution statements identify conditions or practices that could result in damage to this produce or other property.





DANGER indicates an injury hazard immediately accessible as you read the marking.

WARNING indicates an injury hazard not immediately accessible as you read the marking.

CAUTION indicates a hazard to property including the product.

Symbols on the Product

The following symbols may appear on the product:

			
DANGER High Voltage	Protective Ground (Earth) Terminal	ATTENTION Refer to Manual	Double Insulated

Certifications and Compliance

CSA Certified Power Cords

CSA Certification includes the products and power cords appropriate for use in the North American power network. All other power cords supplied are approved for the country of use.

Preface

This manual describes how to use the Tektronix ST2400A SDH Test Set. This manual is your primary source of information about how the ST2400A SDH Test Set functions.

How This Manual is Organized

This manual is divided into four sections: *Getting Started*, *Operating Basics*, *Reference*, and *Appendices*.

- *Getting Started* provides an overview of the ST2400A SDH Test Set and describes first-time operation.
- *Operating Basics* explains the basic principles of operating the ST2400A. The Operating Basics section also includes sample ST2400A applications.
- *Reference* provides explanations of how to perform detailed tasks.
- The *Appendices* provide a listing of specifications, default factory setting, an incoming inspection test, and other useful information.

Conventions

This manual uses the following conventions:

- The names of front-panel controls and menus appear in all upper case letter, for example, TRANSMIT and HELP.
- Names appear in the same case in this manual as they appear on the display of the ST2400A, for example, Test Duration and USER DEFINED.
- Within a procedure, a specific button to be pressed or a parameter to be selected appears in boldface print.

NOTE! *Some of the content found in this manual does not pertain to some instruments. Depending on the software revision and the options installed, some of the features described in these pages may not be available.*

Related Manuals

The following documents are available for the ST2400A SDH Test Set:

- *ST2400A SDH/SONET Programmer Manual* (Tektronix part number 071-0243-xx) describes how to control the ST2400A using an instrument controller.
- *ST2400A SONET/SDH Test Set Service Manual* (Tektronix part number 071-0244-xx) provides information on maintaining and servicing your instrument to the module level.

Getting Started

Getting Started

This chapter describes the **ST2400A 2.4 Gb/s SDH/SONET Test Set** and provides a list of standard and optional accessories for both the SDH and SONET option and for each of the three configurations: TRANSCEIVER, TRANSMITTER, and RECEIVER.

Unique front panel "Transceiver", "Transmitter", and "Receiver" labels will be affixed to the top right corner of ST2400A, depending on configuration.

Product Description

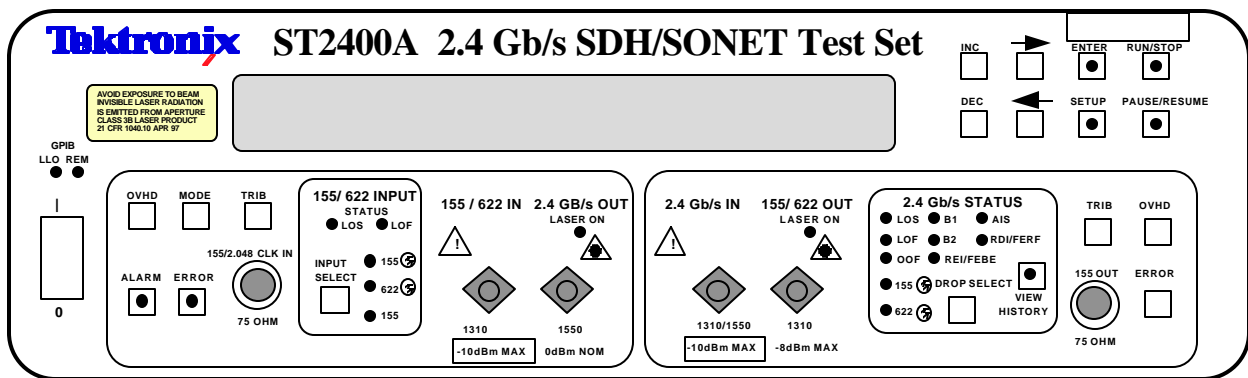

Figure 1-1. Example of ST2400A 2.4 Gb/s SDH/SONET Test Set Front Panel

The **ST2400A 2.4 Gb/s SDH/SONET Test Set** provides Multiplexer Section and Regenerator Section signal generation and analysis for the 2.4 Gb/s SDH STM-16 or SONET OC-48 standards. The ST2400A is a versatile unit that can be ordered in one of three configurations: Transceiver, Transmitter, or Receiver. The front panel design (Figure 1–1) is the same for both the SDH and SONET functions.

The lasers in the ST2400A are Class IIIA per IEC 825-1 for SDH and Class IIIB per 21 CFR 1040 for SONET.

Ordering Information

Options	Description
ST2400A STM-16/OC-48 SDH/SONET Transceiver	
Includes: 2.488 Gbit/s Transmitter and Receiver with electrical clock and data, tributary add/drop, power cord, user manual	
13	Add wideband receive optics and 1310 nm IR 2.488 Gbit/s laser
15	Add wideband receive optics and 1550 nm IR 2.488 Gbit/s laser
17	Add wideband receive optics and switchable 1310 nm IR laser and 1550 nm long-reach 2.488 Gbit/s laser
35	Add wideband receive optics and switchable 1310 nm IR laser and 1550 nm long-reach 2.488 Gbit/s laser
41	STM-16c/ OC-48c payloads
42	Add B3 Path Analysis
ST2400R STM-16/OC-48 SDH/SONET Receiver	
Includes: 2.488 Gbit/s Receiver with electrical clock and data, tributary drop, power cord, user manual	
11	Receive only with 2.4 Gbit/s wideband optics
42	Add B3 Path Analysis
ST2400T STM-16/OC-48 SDH/SONET Transmitter	
Includes: 2.488 Gbit/s Transmitter with electrical clock and data, tributary add, power cord, user manual	
13	Add 1310 nm intermediate-reach 2.488 Gbit/s laser
15	Add 1550 nm long-reach 2.488 Gbit/s laser
17	Add switchable 1310 nm IR laser and 1550 nm long-reach 2.488 Gbit/s laser
35	Add switchable 1310 nm IR laser and G.692 specific frequency long-reach 2.488 Gbit/s laser
41	STM-16c/ OC-48c payloads
42	Add B3 Path Analysis
ST2400A, ST2400R, and ST2400T Common Options	
01	FC/PC optical connectors (Option 01, 02, or 03 must be chosen)
02	SC/PC optical connectors (Option 01, 02, or 03 must be chosen)
03	ST/PC optical connectors (Option 01, 02, or 03 must be chosen)
05	Rack mount
06	FC/PC 15 dB attenuator for 2.488 Gbit/s receiver
07	SC/PC 15 dB attenuator
08	ST/PC 15 dB attenuator
C3	Three year calibration service
C5	Five year calibration service
D3	Three year calibration data report
D5	Five year calibration data report
R5	Extended warranty to five years

Overview, SDH

The ST2400A Transceiver version can transmit and receive STM-16 signals. The ST2400A has the ability to receive, generate and modify an STM-16c signal. The transmitter section can internally generate a 2.4 Gb/s signal or multiplex the higher-rate signal from STM-1 or STM-4 signal inputs. The ST2400A can also accept a STM-16 signal in through mode and regenerate it. The receiver section receives an STM-16 signal, demultiplexes it, and can drop out either the STM-1 or STM-4 signal as required.

The Transmitter version can generate and transmit the STM-16 signal from an internal source, or multiplex the higher-rate signal from either STM-1 or STM-4 signal inputs. In the case of STM-4c and STM-16c, the ST2400A can either generate four STM-4c tributary signals with PRBS payloads inside an STM-16 envelope, or generate three tributary payloads of PRBS STM-4c and insert a fourth from outside the tributary interface (which could contain IP traffic). In the case of STM-16c, the entire (single) payload is PRBS. All applicable SDH Path Pointer Bytes (H1/H2/H3) are set correctly to indicate the type of payload being carried (STM-4c/STM-16c, etc.).

The Receiver version can receive and demultiplex the STM-16 signal and drop either the STM-1 or STM-4 signal to an auxiliary test set, as required.

The ST2400A can accept zero, one or two factory-installed 2.488 Gb/s laser transmitter modules. It can also accept zero or one APD receiver module (also referred to as I/O modules). One type of laser transmitter – direct modulated (DM) – is available.

The ST2400A provides electrical input and output clock and data interfaces operating at 2.488 Gb/s. Base Transceiver configuration provides 2.488 Gb/s electrical interfaces and 155/622 Mb/s optical and electrical add/drop tributary interfaces. Transmitter configurations do not include 155/622 optical and electrical drop interface. Receiver configurations do not include 155/622 optical and electrical add interface.

The user can individually enable and disable laser #1 (if installed), laser #2 (if installed), and electrical outputs. Multiple outputs can be simultaneously active.

NOTE: RX will not measure correctly if both TX lasers are enabled and looped back to RX (since RX contains a single broadband optical detector, which is not wavelength-selective).

The **ST2400A 2.4 Gb/s SDH/SONET Test Set** is designed to integrate directly with other Transmission Analyzers, such as the Tektronix CTS 750 or the Tektronix CTS 850. The ST2400A unit can operate with many other STM-1 and STM-4 test sets that accept 155 or 622 Mb/s optical signals and the 155 Mb/s CMI electrical signal.

ST2400A 2.4 Gb/s SDH/SONET Test Set Features and Capabilities:

- STM-16 SDH RS and MS Testing
 - **B1, B2, B3 Error Generation**
 - B1, B2, B3 Error Measurement
 - Path REI, Path Alarms, Pattern Bit Error
 - J0, J1 Capture; J0 Edit
 - RS and MS Alarm Generation
 - RS and MS Alarm Detection
 - RS and MS Layer Alarm and Error Generation
- VC4 PRBS Mappings
- Ability to receive, generate and modify a STM-16c Payload (Option 41)
- External Clock Input (2 Mbps/ 2 Mhz) or 1.5 Mbps
- User-selectable power failure recovery mode
- Electrical Offset of Receiver Decision Threshold
- +/- 1 nm wavelength tuning
- CW laser source mode
- 2.488 Gb/s electrical I/O
- 3-year warranty
- Automatic Optical Receiver shut-off if power exceeds maximum rating
- Specific wavelengths G.692 lasers available in 1550 nm region
- Portable—11.4 kilograms (25 pounds) maximum weight
- A simple menu system
- Tributary Access at 155 Mb/s or 622 Mb/s
- Easily software switched between SDH and SONET modes
- Integrates with the CTS 750 or CTS 850 for complete “all-rate” SDH analysis
- Wide optical range:
 - 3 dBm to -2 dBm Typical Output Power
 - -28 dBm to -10 dBm Receiver Sensitivity
- Through Mode with Overhead Editing, Error, and Alarm Injection
- Direct user download of software updates

- CCITT/ITU G.708, G.709 and GR-253-CORE framing

- Complete Remote Control
RS-232 and GPIB ports, and standard printer interfaces
LabView, LabWindows CVI, and HP Vee
LAN (using LAN to GPIB converters)
ST2400A GUI Front Panel Utility
- Standard tributary interfaces
STM-1e 155 Mb/s electrical
STM-1 155 Mb/s optical
STM-4 622 Mb/s optical
- Interface to Regenerator Section Terminating Element and Multiplexer Section Terminating Element and other test equipment

With firmware version 5.0 (Option 42), the following new features are added to capabilities of the ST2400A:

- Payload bit error injection/ B3 Injection on the TX side (TSE)
- B3, Path-REI, Payload bit error count measurement on the RX side (TSE ES, SES (SDH only))
- Alarm signal status (RX) - Path RDI, Loss of Pointer, Path AIS, Path REI
- Path Overhead Monitor (RX) - Displays value of following bytes: J1, B3, C2, G1, F2, H4, Z3/F3, Z4, N1
- For the path overhead, C2 byte added at TX (Path Signal Label C2)) - Identifies High Order Path Label Unequipped and High Order Path Label Mismatch. C2 byte can be set to any value from 0x00 to 0xFF.
- B3 Path Analysis/ J1 Path Trace (displayed as ASCII text).
- Tx Patterns. PRBS $2\text{-}31^{-1}$ and $2\text{-}31^{-1}$ Inverted; Fixed (00 to FF) (TX mode button)
- Pointers (Read-only menu under RX Trib button). Pointer Value displayed (0 to 782). Pointer Measurement Counts for Positive Pointer Justifications, Negative Pointer Justifications, New Data Flag (NDF)
- Extended capability of View History button (more LEDs - virtual LEDs)
- APS Switch Time measurement (LOF, LOS durations). APS testing can be performed by causing protection switch via control of K1/K2 bytes and then displaying time to restore frame synchronization. Highly-accurate LOF timer enables this test to be performed with <1 ms resolution.
- RX mapping (PRBS $2\text{-}23^{-1}$ and $2\text{-}23^{-1}$ Inverted; PRBS $2\text{-}31^{-1}$ per ITU-T O.151 and $2\text{-}31^{-1}$ Inverted per ITU-T O.181, User-defined byte 0x00 to 0xFF) (RX Channel Selection, under RX Trib button)

NOTE: Option 42 must be purchased for B3 capabilities (To determine if a TX board is B3 capable, the return value from the remote command "tx_brd_rev" must be greater than or equal to 35. To determine if an RX board is B3 capable, the return value from the remote command "rx_brd_rev" must be greater than or equal to 9).

The ST2400A meets the needs of development, manufacturing, and service engineers by providing the capabilities for:

- System interrogation and conformance testing
- Manufacturing Production Testing
- Network Integrity testing
- Network Performance monitoring
- Network Troubleshooting

Bellcore CLEI and CPR Product Codes

Bellcore COMMON LANGUAGE Product Codes are available for the ST2400A upon request.

Accessories

Some accessories are included with the **ST2400A 2.4 Gb/s SDH/SONET Test Set**. If you wish to purchase optional accessory contact your local Tektronix Representative.

Standard

User Manual; Certificate of Traceable Calibration; Front Cover; Power Cord

Optional

Rackmount

Carrying Case

Interface Cables, RS-232-C, GPIB, Centronics

RS-232-C

012-1379-00	9-pin female to 9-pin male
012-1298-00	9-pin female to 25-pin male
012-1398-00	9 in. RS-232-C to plotter/printer

GPIB

012-0991-00	2m, double-shielded
012-0991-01	1m, double-shielded
012-0991-02	4m, double-shielded
012-1282-00	0.5 m, GPIB

Centronics

012-1233-00	3 m, 4693 to Terminal
012-1214-00	8 ft. Male Centronics to PC 25-Pin D
012-1284-00	9 ft. male to male

Interface Cables, used for CE Certification

1M-BM-SB142-BM	BNC to BNC (50 OHM) 1 meter length
1M-BM-4233-BM	BNC to BNC (75 OHM) 1 meter length
H1740-1	Printer Cable, 8 feet
8004570	DB25 Male to Female, 6 feet
8004569	DB9 Male to Female 6 feet
CIB24-1M	GPIB 1EEE-488 1 meter length
CIB24X	GPIB Adapter

Adapters, SMA

015-0369-00	SMA male to N
015-0572-00	SMA male to BNC male
015-0554-00	SMA male to BNC female
015-1009-00	SMA male to N female
015-0553-00	Threaded female to male slip-on connector
015-0549-00	Male to female connector (Used permanently installed to prolong life of instrument connector)
020-1693-00	SMA Kit

Attenuator, Optical

Recommended:

AMP 06-0033 FC Style Build Out Attenuator 15 dB Fixed Value or equivalent.

Option 1A provides an attenuator.

International Power Plug Options

Option #	Description
A1	220V, Euro Plug
A2	240V, UK Plug
A3	240V, Aust Plug
A4	240V, North American Plug
A5	220V, Swiss Plug

First Time Operation

Unpacking

Unpack the **ST2400A 2.4 Gb/s SDH/SONET Test Set** and place the unit on a hard firm surface.

ST2400A Installation

Before using the ST2400A verify that it is properly set up and powered on, as follows:

1. Remove the unit from its shipping carton and place it on a hard firm surface.
2. Verify that the operating environment is within the limits detailed under the Environmental Requirement section in this manual.
3. Allow approximately 2 inches (5 cm) clearance for cooling on the top and rear of the unit. The two rear panel fans draw air into the ST2400A which is exhausted through the top vents.
4. Connect the unit for a chosen application. Never exceed the maximum optical power limits (-10dBm) listed on the front panel. When not using, always cover the optical connectors.

CAUTION!

Signal levels greater than -10dBm (negative 10dBm) may damage the Optical Input devices. Always pad the input level to less than -10dBm .

Always use 15 dB of attenuation when connecting the ST2400A Transmitter output to its receiver input. Failure to do so will damage the optical detector.

1. Verify that the rear panel key lock is in the desired position.
2. Plug the unit into the appropriate AC Power source as follows:

Table 1-1. Power Requirements

AC Voltage	Voltage Range	Frequency Range	Maximum Power
110 VAC	90 VAC - 132 VAC	48 - 62 Hz	250 Watts
220 VAC	180 VAC - 250 VAC	48 - 62 Hz	250 Watts

Operating Basics

Functional Overview

This section describes **ST2400A 2.4 Gb/s SDH/SONET Test Set** controls, indicators, connectors, display elements, and menu structures. It includes separate sections that detail Receiver and Transmitter specifics, and general sections that apply to both.

Front Panel Controls, Indicators, and Connectors

Figure 2-1 shows a complete view of the front panel.

WARNING! Always avoid exposure to the laser beam. Before power is applied to the **ST2400A 2.4 Gb/s SDH/SONET Test Set**, be sure that all laser outputs are either covered with the screw cap provided or connected to the appropriate circuit.

The lasers in the ST2400A (SDH) are Class IIIA per IEC 825-1.

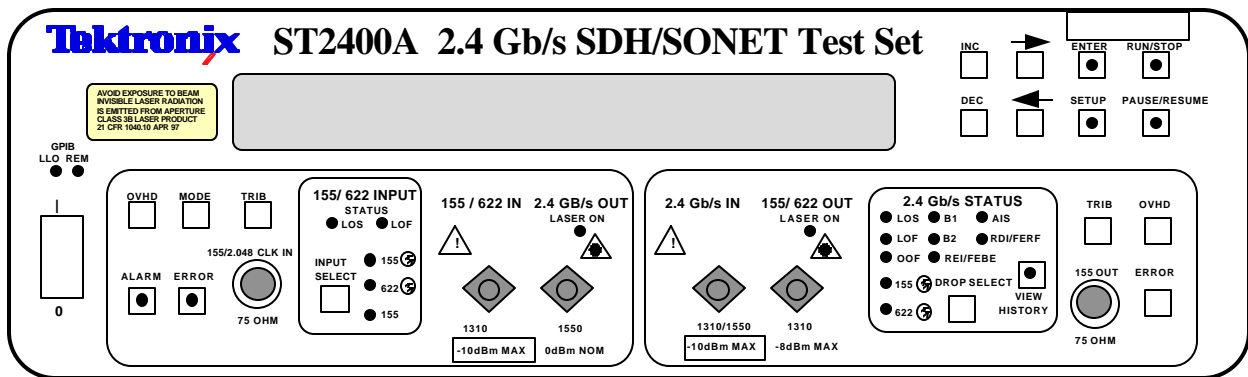

Figure 2-1. Example of ST2400A Front Panel

The front panel can be divided into functional sections:

- Display and Display Controls
- Transmitter Controls and Connectors (Left-side of front panel)
- Receiver Controls and Connectors (Right-side of front panel)

Display, Display Controls, and Indicators

The figure below shows the **ST2400A 2.4 Gb/s SDH/SONET Test Set** display and display controls. The display is a two-line by twenty-four character back-lit super twisted Nematic LCD (liquid crystal display) that provides a sharp image and increased viewing angle in all directions.

The LCD display is used to present main menus, submenus, and test results. The right and left arrows are used to position the LCD cursor. The INC (increment) and DEC (decrement) keys are used to change values. The ENTER key is used to insert the selected value.

The ENTER key houses a red LED indicator that flashes whenever an action is requested or required. It will continue to flash until the ENTER key is pressed, entering a new value or executing the function.



Figure 2-2. ST2400A LCD Display

Setup Menu System

The SETUP key is located below the ENTER key on the front panel. Pressing the SETUP key at any time will start the menu sequence. Each additional press, represented by the black arrow, will access the next menu. The number of main menus is mode dependent. Some main menus have submenus, omitted in this chapter, but detailed in *Chapter 3- Reference*. The SETUP menus are arranged in a continuous loop. Press any other key to exit the setup mode.

WARNING!

Before activating the 2.4 Gb/s LASER, its output must be connected to a circuit.

CAUTION!

Signal levels greater than -10dBm (negative 10dBm) may damage the Optical Input devices. Always attenuate the input level to less than -10dBm .

Always use 15 dB of attenuation when connecting the ST2400A Transmitter output to its Receiver input. Failure to do so will damage the optical detector.

Examples of SDH Setup Main Menus (depending on Configuration)

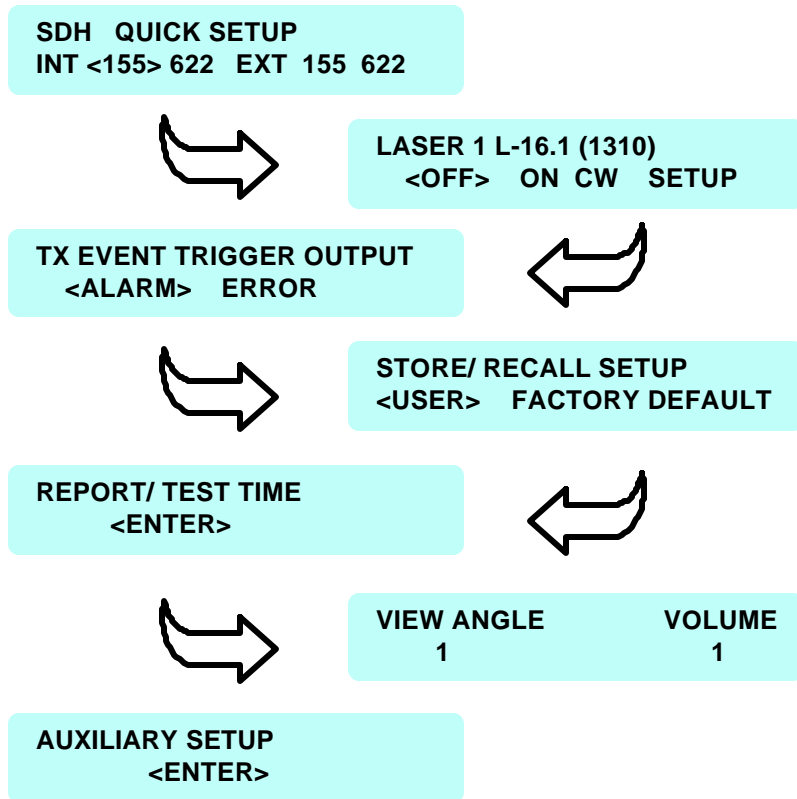

Figure 2-3. Examples of SDH Setup Main Menus

Since the ST2400A can be configured as Transceiver, Transmitter or Receiver, many menus are available only with the appropriate configuration.

For example, the Quick Setup menu displayed above is available with the Transceiver, but does not appear in the Transmitter or Receiver configurations. The TX Event Trigger Output menu is available in the Transceiver or Transmitter configurations. The Report/Test Time menu is available in the Transceiver or Receiver configurations.

Transmitter Description

This section describes the Transmitter inputs, outputs, controls and indicators. The figure below shows the **ST2400A 2.4 Gb/s SDH/SONET Test Set Transmitter** front panel area, located on the left side of the front panel. The Transmitter button choices are not functional on the ST2400A configured as a Receiver.

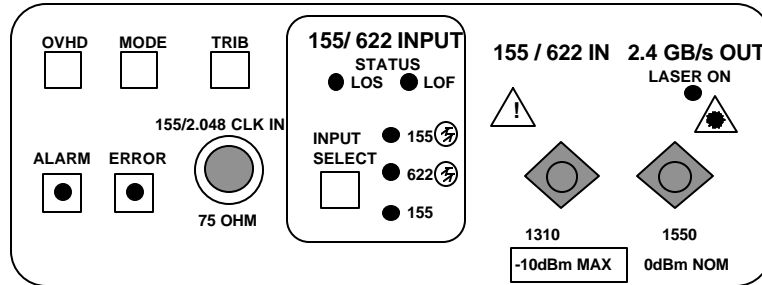

Figure 2-4. Transmitter Front Panel

Transmitter Connectors

There can be three connectors on the Transmitter front panel—one electrical CMI (Code Mark Inversion) (155 electrical) and two optical. The CMI electrical carrier connector is an industry standard BNC that is marked **155/2.048 CLK IN**. It provides a 75 ohm load impedance and direct coupling (DC) for the 155 Mb/s SDH electrical signal.

This connection also accepts 2.048 Mb/s or 2.048 MHz \pm 40 PPM SETS input for internal signal generation using external timing synchronization. SETS input accepts signals meeting the requirements of G.703 section 10 (2.048 Mb/s) and section 6 (2.048 Mhz), with the exception of frequency tolerance of \pm 40 PPM. The user will have the ability to select which of the timing sources (internal or external 2.048 Mb/s or 2.048 MHz) is active. When an external clock source is selected, but no clock activity is detected, the user will be alerted to Loss of External Clock.

On the right side of the Transmitter section are two industry standard FC/PC optical connectors—one input and one output. ST and SC connectors are available as an option. The input optical connector is marked **155/622 IN**; it accepts either STM-1 or STM-4 signals, at 1310nm. The output optical connector is marked **2.4 Gb/s OUT**; it outputs an STM-16 signal. Both are equipped with screw caps to protect the optics from airborne contamination, such as dust.

WARNING!

Before activating the 2.4 Gb/s LASER its output must be connected to a circuit.

CAUTION!

Always use 15 dB of attenuation when connecting the ST2400A Transmitter output to its Receiver input. Failure to do so will damage the optical detector.

Transmitter Status Indicators

The **155/622 INPUT STATUS** section has five LED indicators—three yellow and two red. The **SELECT** key is used to choose between the two optical inputs and one electrical. When the input is external, the yellow LEDs indicate which input has been chosen.

The two red indicators are labeled **LOS** (Loss Of Signal) and **LOF** (Loss Of Frame). They monitor the 155 and 622 inputs for those alarm conditions. Both LEDs are off when the appropriate incoming signal is present. They are disabled when the unit is internally generating a 2.4 Gb/s or is in the through mode (see the *Mode Key* section).

Mode Key

Pressing the **MODE** key will access the Transmitter input selection menu. It is used to choose one of the three data sources that will produce the 2.4 Gb/s output signal and select the wavelength when a dual wavelength Transmitter option is installed. The three choices are: **EXT**, an external input tributary from the Transmitter front panel; **INT**, an internally generated 2.4 Gb/s signal; and **THRU**, a through input from the Receiver section. There are also choices for Pattern Selection, Mapping Selection, and External Sync Input options under the **MODE** key.

The **EXT** input can be 155 Mb/s optical (**STM-1**), 622 Mb/s optical (**STM-4**), or 155 Mb/s CMI electrical signal. The appropriate yellow status LED will indicate the input signal.

The **INT** mode generates an unequipped SDH 2.4 Gb/s (**STM-16**) signal with valid transport overhead bytes that can be modified.

The Transceiver **THRU** mode will output a modified 2.4 Gb/s SDH signal that entered the Receiver section from an external source before modification. All three yellow status LEDs will be off when the ST2400A is in the **THRU** (Through) mode or **INT** mode.

The Transceiver **WAVELENGTH** menu will only be present when the dual wavelength option is installed. Use the arrow keys to move the cursor to either 1310nm or 1550nm and the enter key to select the value.

Tributary and Input Select Keys, Transmitter

The Transmitter **TRIB** key is used with the **INPUT SELECT** key to configure input groupings. **STM-16** has sixteen **STM-1** channel groups or four **STM-4** channel groups.

OVHD Key, Transmitter

The Transmitter OVHD (Overhead) key provides access to the Regenerator Section and Multiplexer Section overhead bytes in the first column of the first STM-1. The figure below shows the menu used to access the E1 byte. A field change occurs when an arrow key is used to move the cursor from PASS to SET. The field change shows the current value of the particular overhead byte being viewed. Greater detail is provided in *Chapter 3 - Reference*.

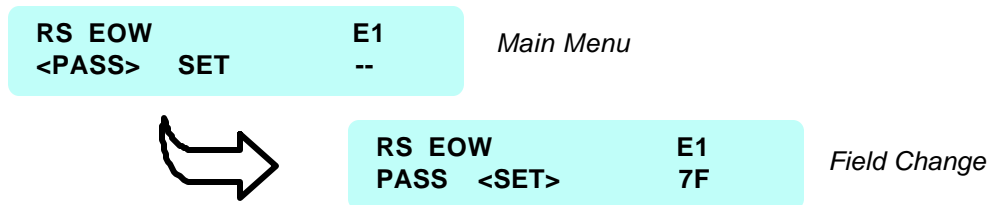

Figure 2-5. Overhead Menu Access

Alarm Key, Transmitter

The Transmitter alarm key is used to inject any of the alarms in one of four modes: continuous, timed, burst, or repeat at specific intervals. The alarm displays and menus are detailed in the next chapter. The red LED indicator in the alarm key will be illuminated whenever an alarm is active.

Error Key, Transmitter

The Transmitter error key is used to generate specific error conditions that are detailed in *Chapter 3 - Reference*. The red LED indicator in the error key will be illuminated whenever an alarm is active.

Receiver Description

This section describes the **ST2400A 2.4 Gb/s SDH/SONET Test Set Receiver** front panel inputs, outputs, controls, and indicators, located on the right side of the front panel. The Receiver button choices are not functional on the ST2400A configured as a Transmitter.

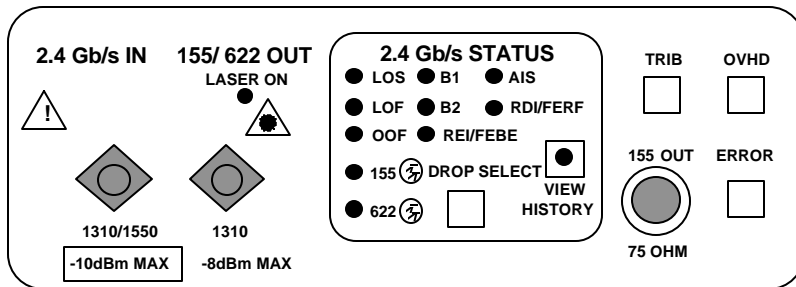

Figure 2-6. Receiver Front Panel

Receiver Connectors

There are three connectors on the Receiver front panel—one electrical CMI (Code Mark Inversion) and two optical. The CMI electrical signal connector is an industry standard BNC that is marked **155 OUT**. It provides the 75 ohm load impedance and direct coupling (DC) for the SDH electrical signal.

The two industry standard FC/PC optical connectors are on the left side of the Receiver section, one input and one output. ST or SC connectors are available as options. The input optical connector is marked **2.4 Gb/s IN**, it accepts the STM-16 signal, at either 1310 or 1550 nm. The output optical connector, marked **155/622 OUT**, outputs STM-1 and STM-4 tributary signals at 1310 nm. Both are equipped with screw caps to protect the optics from airborne contamination, such as dust.

WARNING!

Before activating the 2.4 Gb/s LASER its output must be connected to a circuit.

CAUTION!

Always use 15 dB of attenuation when connecting the ST2400A Transmitter output to its Receiver input. Failure to do so will damage the optical detector.

Receiver Status Indicators

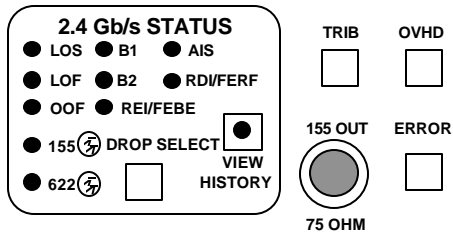

Figure 2-7. Receiver Status Indicators

The status indicators include the alarms and errors detailed below. The appropriate LED indicator will light for a minimum of 200 milliseconds when a corresponding alarm or error is detected. Detected errors and alarms are stored as historical data.

The Receiver LOS (Loss Of Signal) alarm indicates that the 2.4 Gb/s Input signal has not been detected for more than 2 microseconds. The LOS alarm will be asserted no later than 127 microseconds after receiving the low signal (all zero) condition.

The Receiver LOF (Loss Of Frame) alarm indicates that more than 3 milliseconds of an *out of frame* condition has occurred.

The OOF (Out Of Frame) alarm indicates that more than 4 consecutive frames of the 2.4 Gb/s signal had frame alignment errors.

The B1 and B2 LEDs indicate that Regenerator Section or Multiplexer Section (respectively) parity errors were detected.

The REI/FEBE (Remote Error Indication or Far End Block Error) indicates that a non-zero value in the REI byte (M1 byte in MS-OH) was detected.

The RDI/FERF (Remote Defect Indication or Far End Receive Failure) alarm indicates that bits 6, 7, and 8 of the K2 byte have been a binary 110, respectively, for three or more consecutive frames.

The AIS (Alarm Indication Signal) indicates that bits 6, 7, and 8 of the K2 byte have been a binary 111, respectively, for three or more consecutive frames.

The 155 and 622 LEDs function in conjunction with the DROP SELECT key to indicate which optical drop rate has been selected. Both LEDs are off when the 155 Mb/s electrical drop is selected.

View History Key

The VIEW HISTORY key reviews past alarms and errors. A history status bit is set, and the status LED built into the key flashes whenever an alarm or error is detected during the run mode. Pressing this key will display the history status of the alarm and error LED indicators instead of the current status. Releasing this key will return to the current status display within 200 milliseconds. History is cleared when a new test cycle starts.

The VIEW HISTORY key also permits the display of additional LED indicators.

Any error or alarm on PATH will cause the VIEW HISTORY light to blink.

There are three status indicators in the menu below. The "-" indicates a cleared condition (no errors of this type have been detected since the test began). The "*" indicates a present error condition (an error of this type is now occurring). The "h" indicates a history condition (an error of this type occurred at some point during the test, but is not occurring at this time).

B3	h	PL-BIT	*	P-REI	--
LOP	-	P-AIS	h	P-RDI	--

Figure 2-8. VIEW HISTORY additional LED indicators (SDH)

Drop Select Key, Receiver

The DROP SELECT key is used to select one of three drops from the 2.4 Gb/s (STM-16) signal. The 155 Mb/s signal (STM-1) can be either electrical or optical. The 622 Mb/s (STM-4) signal is always optical.

Tributary Select Key, Receiver

The Receiver TRIB key is used to select the drop side tributaries. One of sixteen 155 Mb/s (STM-1) tributaries or one of four 622 Mb/s (STM-4) tributaries can be selected from the 2.4 Gb/s (STM-16) signal. The Drop Select Key was used to choose either the STM-1 or STM-4 drop.

OVHD Key, Receiver

The Receiver OVHD (Overhead) key permits viewing of the Regenerator Section (RS) and Multiplex Section (MS) overhead bytes in the first column of the first STM-16 frame, including APS (Automatic Protection Switching). Some of these bytes may be used to perform testing—review the *OVHD Key, Transmitter* section previously presented in this chapter.

Measurement Controls and Indicators

The **ST2400A 2.4 Gb/s SDH/SONET Test Set** Measurement Controls and indicators are located at the top right-side of the front panel. The RUN/STOP key provides duration control over the test cycle. RUN clears all counters, clears history data, and starts the test cycle. STOP halts the test cycle without effecting counter values. The green LED indicator, inside the key, is on during the RUN cycle. A stopped test can be restarted using the pause-run-resume sequence, saving stored history data. The button choices are not functional on the ST2400A configured as a Transmitter.

The PAUSE/RESUME key permits a temporary stop of the test cycle. The red LED indicator is on when the test cycle is in the pause mode. Pressing the key, once again, extinguishes the LED and resumes the test. All counters are suspended in the PAUSE mode and continue from that point when the test cycle is resumed (RESUME).

Front Panel Connections

155 Electrical Add Input / 2.048 Ext Ref Clock Input (BNC)

This BNC connector is mounted on front panel 155e Input of all configurations. This connector is only used in Transceiver and Transmitter configurations.

155 Electrical Drop Output (BNC)

This BNC connector is mounted on front panel 155e Output of all configurations. This connector is only used in Transceiver and Receiver configurations.

155/622 Optical Add Input (FC, SC, or ST)

An optical connector bulkhead plus cap and chain is mounted on front panel 155/622 Optical Input of all configurations. Bulkhead type (FC, SC, or ST) depends on customer-specified optical connector type (required customer option). 155/622 Add optics will be installed and fiber connected to this bulkhead only in TX/RX and TX Only configurations.

155/622 Optical Drop Output (FC, SC, or ST)

An optical connector bulkhead (customer-specified as FC, SC, or ST) plus cap and chain is mounted on front panel 155/622 Optical Output of all configurations. 155/622 Drop optics will be installed and fiber connected to this bulkhead only in TX/RX and RX Only configurations.

TX 2.4 Gb/s Optical Output (FC, SC, or ST)

An optical connector bulkhead (customer-specified as FC, SC, or ST) plus cap and chain is mounted on front panel 2.4 Gb/s Output of all configurations. No fiber is connected to this bulkhead in RX Only configurations. Optical connector from 2.4 Gb/s TX laser(s) is attached to this bulkhead only in TX/RX and TX Only configurations when 1 or 2 optional lasers are ordered.

RX 2.4 Gb/s Optical Input (FC, SC, or ST)

An optical connector bulkhead (customer-specified as FC, SC, or ST) plus cap and chain is mounted on front panel 2.4 Gb/s Input of all configurations. No fiber is connected to this bulkhead in TX Only configurations. Optical connector is fiber-connected to APD RX only in TX/RX and RX Only configurations when optional APD RX is installed.

Remote Indicators

The two GPIB front panel LED status indicators are located on the left side of the front panel. The Remote Operation (REM) LED indicates that the ST2400A is being controlled through its GPIB connection. The REM LED is off when the unit is in the local mode or is being controlled by an RS-232C connection. Front panel control is restored when the SETUP key is pressed.

In the Local Lockout (LLO) mode, the **ST2400A 2.4 Gb/s SDH/SONET Test Set** front panel is disabled by a remote controller that is using GPIB access commands. Front panel control can only be restored by the appropriate GPIB command or by a power initialization cycle. Power initialization should only be used when the ST2400A is not being remotely operated.

Rear Panel Description

This section describes the rear panel controls and connectors.

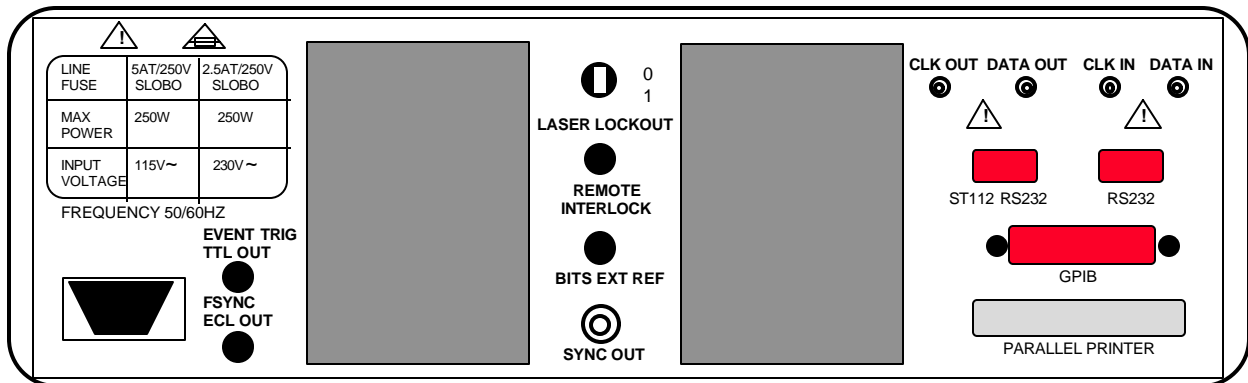

Figure 2-9. Rear Panel - ST2400A

The AC power module is located in the lower left-hand corner of the rear panel. It has a removable fuse panel that can be opened with a small flat blade screw driver after the AC Line Cord has been unplugged. The AC power supply automatically detects and switches to accept either 115 (90 to 130 VAC or 230 (180 to 250) VAC inputs. A 5AT fuse is used with the 115 source voltage and a 2.5AT fuse is used with the 230 source voltage.

⚠ WARNING! Always disconnect the AC Power Cord before opening the fuse panel or disconnecting the rear panel AC interlock.

Laser Lockout, Remote Interlock

LASER LOCKOUT is a safety device. The key switch disables the Transmitter's 2.4 Gb/s laser output when it is turned to the 0 (zero) position. The laser output can only be turned on when the key is in the 1 (one) position.

REMOTE INTERLOCK is a bantam plug normally closed connection internally wired in series with the laser lockout key switch. It can be used with additional hardware to disable the Transmitter 2.4 Gb/s laser output.

NOTE: The Transmitter 2.4 Gb/s Laser output cannot be enabled unless:

- The Laser Lockout key switch is set to the on (1) position.
- The Remote Interlock, which is normally enabled, is either not used or externally enabled.
- The Laser output is software enabled.



WARNING!

Before activating the 2.4 Gb/s LASER, its output must be connected to a circuit.



CAUTION!

Always use 15 dB of attenuation when connecting the ST2400A Transmitter output to its Receiver input. Failure to do so will damage the optical detector.

SYNC Output (SMA)

SYNC Output (Clock Trigger) is an AC-coupled output. The voltage level is 300 mV peak-to-peak minimum. This output requires an external 50-Ohm termination to work properly. This output generates a sync output signal at 1/8 data rate (311 Mhz), useful for triggering an oscilloscope to measure the eye diagram of an OC-48/STM-16 signal.

BITS Ext Ref

In addition to the external 2.048 Mb/s or 2 MHz SETS timing input on the front panel, the ST2400A accepts 1.544 Mb/s \pm 40 PPM BITS input for internal signal generation using external timing synchronization. BITS input accepts signals meeting the requirements of ANSI T1.101-1994 with the exception of frequency tolerance of \pm 40 PPM.

BITS external timing input is a Bantam connector mounted on ST2400A rear panel. The Rear panel connector is labeled BITS Ext Ref, to indicate its input timing function.

The user has the ability to select which of the timing sources (internal, ext 1.544 Mb/s, or ext 2.048 Mb/s/MHz) is active. When an external clock source is detected, but no clock activity is detected, the user is alerted to Loss of External Clock, via a front panel message.

Rear Panel Connectors

Four SMA, two BNC, two 9-pin RS-232, one GPIB, and one parallel printer connectors are mounted on the rear panel.

Event Trigger and Frame Sync signals are accessible through individual BNC connectors located on the lower left rear panel. Either can be connected to an event counter or used to trigger an oscilloscope.

- The Event Trigger (EVENT TRIG) is a TTL output that is generated by any one of the following Transmitter programmed alarm or error conditions (AIS, RDI/FERF, LOS, and frame errors—including LOF), or by changing an overhead byte value. The event trigger signal is a minimum of 2.4 V_{peak}, with a pulse width of 25 ns \pm 10%, and leads the event by less than 1 μ s.
- The Frame Sync (FSYNC) has an ECL output that is generated by the transmitted framing bytes, A1 and A2. The frame sync signal is a minimum of 600 mV_{pp}, with a pulse width of 25 ns \pm 10%. The pulse repetition rate is equal to the 125

The ST2400A provides single-ended 2.488 Gb/s clock and data interface inputs and outputs, mounted on the rear panel. Electrical clock and data outputs are unterminated ECL signals, requiring connection to AC-coupled 50 Ohm termination through a bias-tee network supplying current for the ECL outputs. Electrical clock and data inputs are AC-coupled with 50 Ohm termination, allowing ST2400A to operate error-free when electrical TX outputs are looped back to electrical RX inputs, through an external bias-tee termination. Clock and data connectors are SMA-style. The connectors are labeled to indicate Clock Out, Data Out, Clock In, and Data In.

The two DB-9 receptacles are RS-232C 9-pin serial interface connectors. One is marked for use with the Tektronix ST112. The ST112 is only supported in the SONET configuration or mode. The other is marked RS232. It can be used for remote operations or with a serial printer.

The GPIB receptacle is an IEEE-488.2 standard connector provided for remote operation.

The DB-25 receptacle is a Centronics parallel printer interface.

Applications and Use

This section provides three common examples of telecommunication network applications. It details how the **ST2400A 2.4 Gb/s SDH/SONET Test Set** can be used for:

- Passive Monitoring (Receive-Only)
- Active Analysis
- Active Through Mode Analysis

Common **ST2400A 2.4 Gb/s SDH/SONET Test Set** applications such as field service troubleshooting, engineering analysis, production testing and maintenance will be similar.

Passive Monitoring

The passive monitoring application monitors the 2.4 Gb/s signal. It uses a passive coupler to connect and disconnect the ST2400A without disrupting live traffic.

This setup is used for non-intrusive network monitoring applications. It is perfect for LEC/IXC (local exchange carrier / inter-exchange carrier) cross-boundary or other long-term, passive performance monitoring. It does not allow optical line error injection testing.

This installation splits the STM-16 optical signal through a passive coupler, which can be mounted in an optical cross-connect bay or other convenient location. Since there is no active regeneration of the optical line, the system under test must have adequate margin to accommodate the coupler insertion loss. Measurements are made with the ST2400A, as required.

The CTS850, ST112, or another SDH/SONET tributary test set can be used with the ST2400A to expand its test capabilities. The ST2400A Receive-Only model is particularly economical for passive monitoring applications.

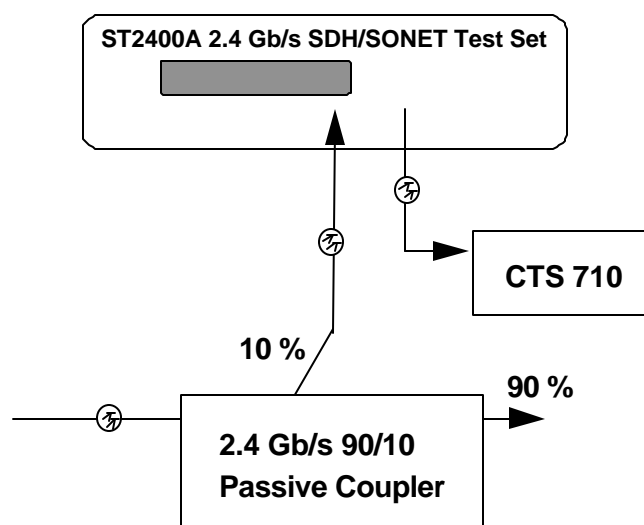

Figure 2-10. ST2400A Passive Monitoring

Active Analysis

The Active Analysis application inserts the ST2400A into an active signal path. This configuration is suitable for test or maintenance operation where live traffic is not being carried over the network, network element, or unit under test.

In this application, the CTS 850 or CTS 750 test set can provide the 155 Mb/s or 622 Mb/s framed signal input to the ST2400A, which is actively inserted into the signal path. The ST2400A provides a variety of signal and analysis options for complete testing of the 2.4 Gb/s. Payload level testing can be done by applying the 155 or 622 Mb/s signal to the auxiliary test set.

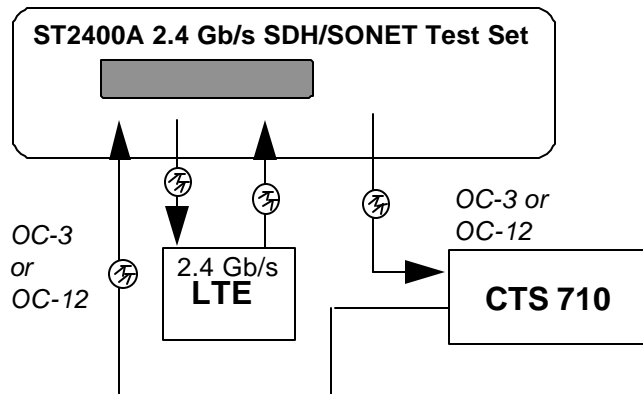

Figure 2-11. ST2400A Active Analysis

Active Through Mode Analysis

The Active Through Mode Analysis of the 2.4 Gb/s Line is similar to the Active Analysis application. The ST2400A is actively inserted into the signal path as either a regenerator or as a stress tester. The STM-16 signal is looped through the ST2400A. The signal can be passed through and regenerated unchanged or alarms and errors can be added for conformance and stress testing. The ST2400A now has the capabilities to add B1, B2, and B3 errors as well as provide error analysis in active through mode.

The ST2400A can be used with a companion test set (CTS710) to make all of the transmission measurements required to completely test the network system. Or the ST2400A can be used without the additional tributary test set to quickly test, monitor, and verify the 2.4 Gb/s signal operation.

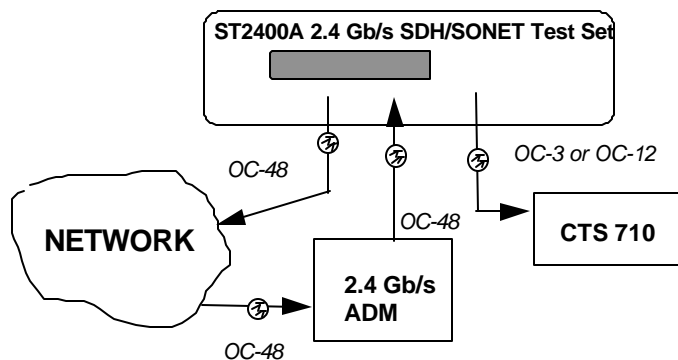

Figure 2-12. ST2400A Passive Monitoring

Example - STM-16c/ OC-48c Application

To test STM-16c/ OC-48c network equipment (such as a large backbone router), place the ST2400A in Active Through Mode, where it will regenerate everything received from the router and send it back out through the Transmit port. The user can then create bit errors in the payload or alarms. If the router is inserting IP traffic in the STM-16c/ OC-48c payload, the ST2400A has the ability to damage or stress-test the IP packets under different error conditions.

Another application places the unit in internal mode, generating an STM-4c/ OC-12c or STM-16c/ OC-48c signal. This signal can be fed into a piece of network equipment with different alarms to test the equipment for specification conformance.

Older ST2400/ST2400A SDH versions and STM-16c

Older ST2400/ST2400A instruments can be used to receive and monitor STM-16c SDH signals. An ST2400A with Option 41 can receive, generate and modify STM-16c signals. The Basic instrument provides capabilities for the following measurements:

LOS	Loss of Signal
LOF	Loss of Frame
OOF	Out of Frame
B1/B2	Performance monitoring
REI	Remote End Indication
RDI	Remote Defect Indication
BER	BER measurements based on B1 and B2 errors

With concatenated signals, the H1 and H2 byte 1 locations contain the location of the payload start container. All other H1 and H2 byte (locations 2 to 48) contain a unique data pattern identifying the data as concatenated.

These patterns, according to ITU-T G.703, are:

H1= 1001xx11

H2 = 11111111

When monitoring concatenated signals, lower rate signals can not be dropped. This capability to monitor concatenated signals is a RX-only function in older ST2400 and ST2400A models. STM-16c signals must be generated from a network element.

Again, an ST2400A with Option 41 can receive, generate and modify STM-16c signals.

Reference

Reference

This chapter describes the use of the **ST2400A** LCD menu structures and displays. In addition to general displays and menus, there are separate sections that detail Setup, Receiver, and Transmitter specifics. A functional verification procedure can be found in the Appendices.

Setup Menus

Pressing the Setup key at any time will bring up the Setup Menus.

Both the Setup and the Enter keys are used to navigate through this menu system. The left and right arrow keys, and the increment (INC) and decrement (DEC) keys are used to change values. The Enter key is also used to access submenus.

The Main Menus that make up the Setup menu are shown in Figure 3-1. The Main Menus are a continuous loop that begins with the Quick Setup LCD display and ends with the Auxiliary Setup display menu. As noted in the figure, the word XXXxx can be either SDH or SONET. That choice is made in the System Configuration submenu of the Auxiliary Setup menus shown at the bottom of Figure 3-2.

One note - Since the ST2400A can be configured as Transceiver, Transmitter or Receiver, many menus are available only with the appropriate configuration.

For example, the Quick Setup menu mentioned above is available with the Transceiver, but does not appear in the Transmitter or Receiver configurations.

This manual details the SDH features.

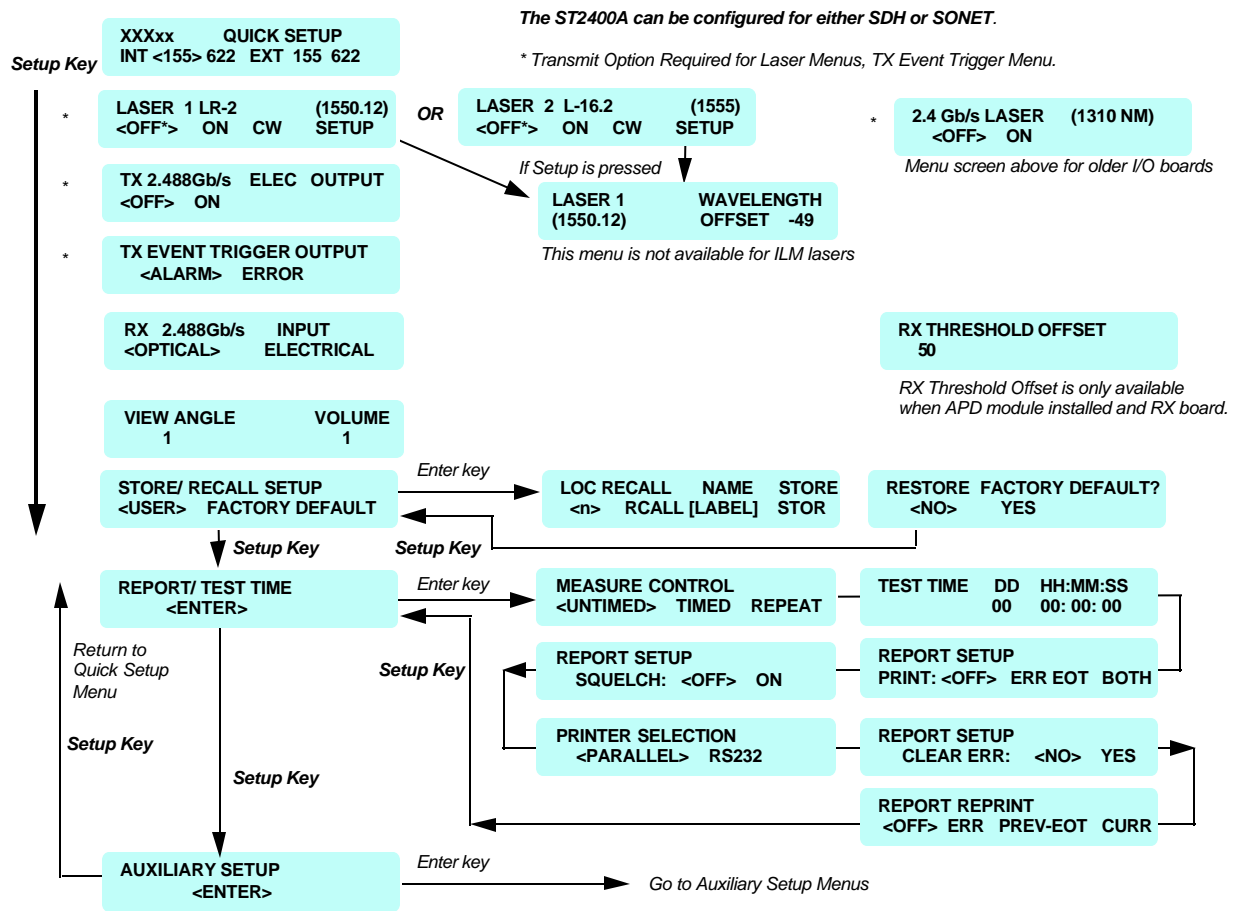

Figure 3-1. Quick Setup Menus

Since the ST2400A can be configured as Transceiver, Transmitter or Receiver, many menus are available only with the appropriate configuration.

For example, the Quick Setup menu mentioned above is available with the Transceiver, but does not appear in the Transmitter or Receiver configurations.

A menu with the "TX" label (such as TX EVENT TRIGGER OUTPUT or TX 2.488 Gb/s ELEC OUTPUT) is not available in an ST2400A configured as a Receiver. A menu with the "RX" label (such as RX THRESHOLD OFFSET or RX 2.488 Gb/s INPUT) is not available in an ST2400A configured as a Transmitter.

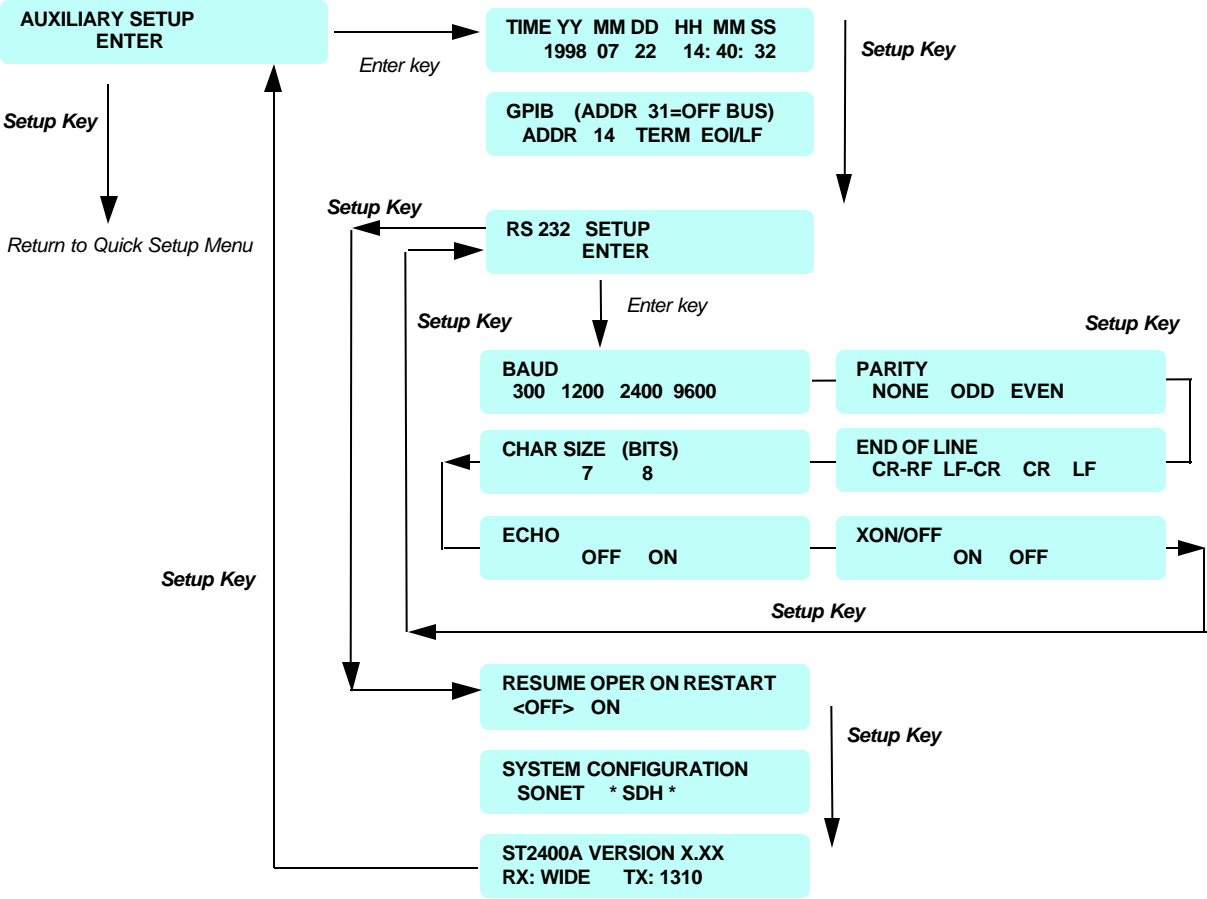

Figure 3-2. Auxiliary Setup Menus

When power is applied, the first three LCD displays will show:

1. The *Tektronix Products* logo and *Copyright* notice.
2. Performing Self-test and Serial Number.
3. *ST2400A* logotype and *Software Version* number and all front panel LEDs will illuminate, verifying their operation.

The third power-up LCD display and all of the illuminated LED indicators will be continuously displayed when you press and hold the VIEW HISTORY key before the power switch is set to on, and continue to hold it in during the power up cycle. The Quick Setup LCD will not be displayed until you release the VIEW HISTORY key.

The next LCD display is the QUICK SETUP menu. The menu choices are used to select the Receiver drop frequencies, either 155 Mb/s (STM-1) or 622 Mb/s (STM-4), from either an internally (INT) generated 2.4 Gb/s (STM-16) rate or an externally (EXT) supplied 2.4 Gb/s (STM-16) rate. When the choice is made, by pressing the Enter key, alarms and errors, if on, will be turned off. Overhead byte values will be reset and set to pass mode. The next menu will be automatically displayed.

 **WARNING!**

Before activating the 2.4 Gb/s LASER, its output must be connected to a circuit.

 **CAUTION!**

Always use 15 dB of attenuation when connecting the ST2400A Transmitter output to its Receiver input. Failure to do so will damage the optical detector.

Laser Menus

Press the Setup key to access the **LASER** menus. The Laser is off when the ST2400A is first powered on and can only be activated when the rear panel laser lockout key-lock is in the on position. To activate the laser, use either arrow key to move the cursor to the *ON* position, then press the Enter key. The laser has a five second delay when activated. A power recovery and test resume after restart capability is user-selectable. See the Power Fail Recovery section for details.

If an older I/O board is installed in the ST2400A, the menu below will appear to enable laser operation.

2.4Gb/s	LASER
<OFF>	ON

Active” operational state of the lasers in each of these menus will be marked with an asterisk.

The next menu appears when the SETUP selection is chosen from the LASER 1 OR LASER 2 menus shown above. This menu configures the specific laser module selected. The "LASER" number is dynamic and specific to the module which is being configured. Laser Wavelength is offset from -50 to +49.

LASER 1	WAVELENGTH	
(1550.12)	OFFSET	-49

In the next menu, when “**OPTICAL**” is selected, the internal APD Receiver will be enabled, **ELECTRICAL**” is selected the APD Receiver will be disabled, electrical input will be used and the LOS front panel LED will be invalid. If no RX board or no APD Receiver is present the next menu shown will not be available and “**ELECTRICAL**” output will be automatically enabled.

TX 2.488 Gb/s	ELEC	OUTPUT
<OFF>	ON	

TX Event Trigger Output Menu

Another push of the Setup key will access the **TX EVENT TRIGGER OUTPUT** menu. It is used to select whether an alarm or an error condition will be used to generate the event trigger pulse from the rear panel BNC connector. The event trigger is 2.4 V_{peak} minimum, with a pulse width of 25 nS ±10%, and leads the event by less than 1µs. It can be used to synchronize other equipment, such as an oscilloscope trigger source. The TX Event Trigger Output menu is available in the Transceiver or Transmitter configurations.

TX EVENT TRIGGER OUTPUT
<ALARM> ERROR

The next menu is available in the Transceiver or Receiver configurations.

RX 2.488 Gb/s	INPUT
<OPTICAL>	ELECTRICAL

In the next menu, RX Threshold Offset is only available when an APD module is installed in the ST2400A. RX Threshold Offset is adjustable from -50 to +49. At 0 offset, RX threshold is at optimal point as determined by the average input signal level.

RX THRESHOLD OFFSET
50

The following menu will appear any time an APD overload occurs, the user must reduce input power and press “**RESET**” to reset the trip circuitry. The user may choose to ignore this message and press "BYP" to bypass this menu. However, the APD circuitry will remain disabled until input power is reduced and the "**RX 2.488 Gb/s Input**" menu is changed to OPTICAL.

RX OPTICS DISABLED

ATTENUATE & <RESET> BYP
--

View Angle Menu

The **VIEW ANGLE** can be set to one of eight integers (0 through 7). Zero should be the best view angle when the ST2400A is positioned below the operator and 7 is best when the operator is looking up at the ST2400A front panel. The change is interactive; it is executed whenever the increment or decrement key is pressed. In the same menu, the **VOLUME** can be set using integers 0 through 9. Zero is off and 9 is the loudest. Errors and alarms activate the beeper, unless the volume is set to zero. The operator setting will be retained when the Test Set is powered off.

Store/Recall Setup Menu

The **STORE/RECALL SETUP** menu is next. It is used to access either the **USER** stored setup or the **FACTORY DEFAULT** setup. Pressing the Enter key will access the submenu from which one of the ten **LOC** (locations) can be **RCLL** (recalled) or **STOR** (stored). Up to ten individual user setups can be saved in memory locations 0 through 9. A unique 10 character label can be stored with each saved setup. The arrow keys are used to position the cursor anywhere in the label area, and the **INC** or **DEC** key is used to scroll through the ASCII characters—including numbers and symbols. Moving the cursor to **FACTORY DEFAULT** and pressing the Enter key will access that **NO** or **YES** menu—that defaults to **NO**. Moving the cursor to **YES** and pressing the Enter key will restore the factory default configuration. Pressing the Setup key will return to the **STORE/RECALL SETUP** display.

STORE/ RECALL SETUP <USER> FACTORY DEFAULT
--

Report/Test Time Menu

The **REPORT/TEST TIME** main menu provides access to the seven submenus used to configure the measurement control, test time, and report setup. Pressing the Enter key will access the **MEASURE CONTROL** menu. This menu is available in Transceiver or Receiver configurations.

REPORT/ TEST TIME <ENTER>
--

1. The **MEASURE CONTROL** menu sets the test cycle to be used when the run key is pressed. **UNTIMED** will run until the stop key is pressed. **TIMED** will run the test for the duration of time set in the **TEST TIME** menu. **REPEAT** will run the test for the duration of

time set in the TEST TIME menu, then start the test again. The stop key can stop any test that is running.

2. Next is the TEST TIME menu used to set the test run duration, in terms of days (D), hours (HH), minutes (MM) and seconds (SS). The maximum time supported is 9 days, 23 hours, 59 minutes, and 59 seconds. Press the Enter key to store any changes and the Setup key to move to the next menu.
3. Next is the REPORT SETUP menu used to control the printed report. It can be set to OFF—no printout, ERR—print a report when an error is detected, EOT—print a report summary at the end of test, or BOTH—print on error and at the end of test. The printer can be connected to either the parallel or serial (RS-232C) port. Parallel is the factory default setting.
4. The REPORT SETUP SQUELCH menu is used to limit the total number of errors logged, saving memory space. When squelch is set to ON error recording will stop after 10 consecutive seconds with errors. Then error recording will be resumed after 10 consecutive seconds without any errors.
5. The PRINTER SELECTION menu offers either PARALLEL or RS232 (serial) printer selection. The printer should be connected to the appropriate port on the ST2400A rear panel.
6. In the REPORT SETUP menu CLEAR ERR (error) is used to clear the error log by moving the cursor to YES and pressing the Enter key. It immediately clears the error log and returns to NO after execution. The error log should be cleared before running a long test, preventing buffer overflow. An error log warning message will be displayed when the run key is pressed, if the log is 95% full.
7. The REPORT REPRINT menu is used to print the previous error log (ERR), the previous end of test summary (PREV-EOT), or the current error log (CURR) if it exist.

Auxiliary Setup Menus

AUXILIARY SETUP is the last of the Main Setup menus. See the illustration of this menu tree that appears earlier in this chapter. Pressing the Setup key will loop back to the QUICK SETUP (starting) menu. Pressing the Enter key will access the Auxiliary setup menus.

TIME is the first submenu accessed from the auxiliary setup menu. It is used to store the year current (YY), month (MM), day (DD), hours (HH) minutes (MM), and seconds (SS), in a battery backed memory. Whenever changes are made, the Enter key LED will start flashing. Once set, the operator setting will be retained when the Test Set is powered off.

Use the Setup key to access the **GPIB** port characteristics menu. The port address is an integer from 0 to 31. It can be changed with the INC or DEC keys. The Enter key LED will flash, push it before proceeding. Either an EOI (End-Or-Identify) or EOI/LF (End-Or-Identify with a Line Feed) can be used to terminate the GPIB message sent by the ST2400A.

Next is the **RS 232 SETUP** menu. Pressing the Enter key will access to the first of six port configuration submenus. They store the characteristics for BAUD rate, PARITY, CHAR (character) SIZE, END OF LINE, ECHO, and XON/XOFF (flow control).

Power Fail Recovery

A power recovery and test resume after restart capability is user-selectable. The first choice is Laser turned off on power fail recovery, and the testing does not resume.

The second choice RESUME OPERATION ON RESTART. This choice retains test results and operating mode from before power loss. Resumed test continues accumulating totals with pre-power fail results, rather than restarting test and re-initializing totals. Time of power loss and recovery are recorded, and duration of power loss is indicated.

This menu is available under the AUXILIARY SETUP menu.

RESUME OPER ON RESTART <OFF> ON
--

This menu applies to both TX and RX lasers.

When ON is selected, the TX and RX lasers will automatically be restored to their last operational state prior to the power loss. If the lasers are ON, all error injection and alarm injection will resume, and all previously collected errors will be restored. If the lasers were ON, they will come back on. If the RESUME OPERATION selection is ON, use the proper safety procedures listed throughout this manual. If the lasers were OFF, they will remain off.

On restart, the measurement automatically restarts (continues) if the measurement was active when the power went down. The data collection is delayed by ten (10) seconds to permit the laser to turn on and the device under test (DUT) to settle. Before this change, after a loss of power, a measurement would need to be restored due to the 2.4 Gb/s laser being turned off.

If System Configuration of the test set (SONET or SDH) is changed, the ST2400A will automatically restart.

The **SYSTEM CONFIGURATION** menu can be obtained by pressing the Setup key from the RS 232 SETUP menu. The ST2400A has both SDH and SONET modes. The active mode is set when the unit is powered on. It has an asterisk (*) on both sides. In the Auxiliary Setup Menu figure shown previously, the SDH mode is active. Using the arrow key to move the cursor to SDH and pressing the Enter key to select the SDH mode. A momentary display, that reads:

Pressing the Setup key again will loop to the ST2400A Version X.XX characteristic display. It provides a software version number and the laser wavelength for both the Receiver and Transmitter. A broad-band Receiver, *RX: WIDE*, is shown indicating that both 1310 and 1550 nanometer lasers are supported. The Transmitter wavelength, *TX: DUAL*, indicates that the Transmitter can handle both 1310 or 1550 nanometers lasers simultaneously. In older ST2400 test sets, the Transmitter MODE key is used to change the TX wavelength.

Pressing the Setup key again will return to the AUXILIARY menu in the Quick Setup main menu loop. Another press of the Setup key will, once again, return to the QUICK SETUP main menu display. The Quick Setup menu appears in the Transceiver or Transmitter configurations, but not the Receiver configuration.

General Menus and Displays

Menu and Measurement Refinements

- **Extended range for B2 error rate measurement** - The B2 error counter has been updated to read every 20 ms, instead of every 100 ms, to extend the maximum B2 error rate which can be measured. B2 errors will be accurately counted up to error rates of 1.0E-3 for evenly-distributed errors.
- To determine if a TX board is B3 capable, the return value from the remote command "tx_brd_rev" must be greater than or equal to 35. To determine if an RX board is B3 capable, the return value from the remote command "rx_brd_rev" must be greater than or equal to 9. Menus for B3 Path Analysis will be hidden if the proper hardware is not present in the ST2400A test unit. In order to use the B3 Path Analysis functionality, it is also necessary to purchase Option 42.
- **B3 Path Analysis/ J0, J1 Path Trace** (displayed as ASCII text).
- **Print-on Event** function gives a printed error count for event seconds containing B1, B2 and B3, Pattern Bit, Path REI, Path Alarms, LOP, Path AIS, Path RDI, FEBE-L (MS-REI) errors, as well as, S1/SSM byte changes.
- **Error Reporting** - In both SONET and SDH mode, the ST2400A will provide Total Errors, Errored Seconds (ES), bit error rate (BER) and Severely Errored Seconds (SES) for B1, B2, B3, Payload Bit, FEBE-P (Rath RDI), and FEBE-L (MS-REI) errors. In SDH mode, the ST2400A will provide Errored Blocks (EB) and Background Block Errors (BBE) for G.826 error analysis measurement. In SDH mode, the ST2400A will properly detect and count Consecutively Severely Errored Seconds (CSES) per G.826. In SONET mode, Severely Errored Seconds (SES) will be counted based on SES criteria in GR-253-CORE. Consecutively Severely Errored Seconds will be measured for B1, B2, B3 and MS-REI errors, and displayed in SDH mode only.
- In SDH mode, all overhead, alarms, failures, and errors are displayed or printed in ITU-T terminology (for example, FEBE is REI, FERF is RDI).
- User shall have the ability to retransmit all editable Transport Overhead (TOH) with or without modification. Remaining non-editable TOH shall be retransmitted without modification. B1 and B2 BIP bytes shall be re-computed in THRU mode and may be errored at user request. Other alarms and failures may be injected at user-request.
- **S1 Byte/ SSM** - ST2400A includes S1 byte changes as events which can initiate print-on-event (time-stamped). When Synchronization Status Message (SSM) in S1 byte changes, a time-stamped report of SSM can be printed indicating new SSM contents. SSM byte changes within the S1 byte are decoded in clear text per G.707 (SDH) and GR-253 (SONET).
- **1/8th Rate Sync Output** - ST-2400A shall generate a sync output signal at 1/8 data rate (311 MHz), useful for triggering scope-based eye diagram measurements. Sync output shall

be provided on SMA connector mounted on rear panel. Sync output signal characteristics: AC-coupled, 300 mV pk-pk. Terminate externally with 50 Ohms.

- **Pointers** (Read-only menu under RX Trib button). Pointer Value displayed (0 to 782). Pointer Measurement Counts for Positive Pointer Justifications, Negative Pointer Justifications, New Data Flag (NDF)

Transmitter or Receiver Configurations

The **ST2400A 2.4 Gb/s SDH/SONET Test Set** can be ordered in one of three configurations, which are: Transceiver, Transmitter, Or Receiver. This chapter details the menus available in the Transceiver configuration. Go to the appendix for a listing of Transmitter-only or Receiver-only or menus.

The ST2400A shall accept zero, one or two factory-installed 2.488 Gb/s laser Transmitter modules and/or zero or one APD Receiver module (also referred to as I/O modules). Initially, two types of laser Transmitters – direct modulated (DM) and EA-modulated Integrated Laser Module (ILM) – shall be available.

The ST2400A shall also provide electrical input and output clock and data interfaces operating at 2.488 Gb/s. Base Transceiver configuration shall provide 2.488 Gb/s electrical interfaces and 155/622 Mb/s optical and electrical add/drop tributary interfaces. Transmitter configurations will not include 155/622 optical and electrical drop interface (although unused connectors may be mounted). Receiver configurations will not include 155/622 optical and electrical add interface (although unused connectors may be mounted).

In older ST2400 units, the Transmitter version can be easily identified because it lacks the Receiver connectors for *155/622 OUT* and *2.4 Gb/s IN* and it will not detect a Receiver card during the power-on cycle. (Some early models may have all front panel connectors.) Pressing any of the control keys in the Receiver section will cause the following message to be displayed.



RX CARD NOT FOUND
RX CONTROLS DISABLED

Figure 3-3. Receiver Card Not Installed

In older ST2400 units, the Receiver version can be easily identified because it lacks the Transmitter connectors for *155/622 IN* and *2.4 Gb/s OUT* and it will not detect a Transmitter card during the power-on cycle. (Some early models may have all front panel connectors.) Pressing any of the control keys in the Transmitter section will cause the following message to be displayed:



TX CARD NOT FOUND
TX CONTROLS DISABLED

Figure 3-4. Transmitter Card Not Installed

Error Log Display

No additional entries will be logged when the Error Log becomes full. If the Error Log is more than 95% full when the RUN key is pressed, the message below will be displayed. Selecting NO will allow the test to run, but when the error log is full new data will be lost. Selecting YES will clear the error log.

<p>ERROR LOG XX% FULL CLEAR LOG? <NO> YES</p>

Figure 3-5. Error Log Display

Transmitter Menus and Displays

TX Source Mode

Pressing the MODE key will access the TX MODE SELECTION menu. It is used to choose one of the three data modes that will produce the 2.4 Gb/s output signal. The three choices are: an external input (EXT) from the Transmitter front panel 155 or 622 Mb/s inputs, an internally (INT) generated 2.4 Gb/s signal, or a through (THRU) mode from the Receiver's 2.4 Gb/s input connector. The EXT and INT modes function on both the ST2400A Transceiver and ST2400A Transmitter units. The THRU mode only functions on an ST2400A Transceiver unit.

<p>TX MODE SELECTION</p> <p>EXT <INT> THRU</p>

Figure 3-6. Transmitter Input Menu

The EXT input can be 155 Mb/s optical (STM-1), 622 Mb/s optical (STM-4), or 155 Mb/s CMI electrical signal. On the Transmitter 155 / 622 Input Status section there are three yellow LED indicators, two optical and one electrical. The appropriate LED will indicate the input signal.

The INT mode generates an unequipped SDH 2.4 Mb/s (STM-16) signal with valid transport overhead. The first column of the first STM-1 can be modified, adding alarms and errors.

ST2400A LCD Display (SDH)

<p>INT TX MAPPING STRUCTURE</p> <p>VC4: <1> 4C 16C</p>

The menu above will only appear in **SDH** measurement mode.

This menu will be available only if **INTERNAL** mode selected and the correct STM-4c/STM-16c hardware is present. For this menu, **VC4** will be automatically selected, and will be the only available mode.

This menu will not be available in “**EXTERNAL**” or “**THRU**” mode.

If “**EXT**” mode is selected and the TRIB channel is set to “**ALL**”, the “**INT TX TEST PATT**” menu will be unavailable.

Note

If **STS48C** or **VC4-16C** mapping is chosen, Random BER injection is limited to **channel 1** only, and will be forced to **channel 1** if it is not set there already. Also any errors being injected will be stopped when any mapping mode is changed.

Any of the OC-12c/OC-48c (STM-4c/STM-16c) remote commands which are executed in any of the above mentioned “invalid” conditions will fail.

The THRU (Through) mode can be used to pass without modification, or modify, a 2.4 Gb/s SDH signal that entered the Receiver from an external source. All three yellow status LEDs will be off when the ST2400A is in the THRU mode.

In older ST2400 test sets, pressing the MODE key a second time will access the TX WAVELENGTH menu, if the dual wavelength Transmitter option is installed. It is used to switch between 1310 nm and 1550 nm.



Figure 3-7. Transmitter Wavelength Menu (if dual wavelength TX option installed)

External Clock Synchronization

This menu choice is available under the MODE button the front panel (TX side).

2 Mb/2 MHz inputs can be utilized for external timing synchronization. This option will only appear when the "INTERNAL" Transmitter mode is enabled. A "Loss of Signal" message will be displayed on the front panel LCD, if either of these options are selected and the signal is not present. If the 2.048 signal is lost from the front-panel , an error message will appear on the LCD screen - "TX: LOSS OF 2.048 CLK", which will flash on and off in 3-second intervals.



Figure 3-8.External Timing Synchronization (MODE button) (SDH)

PRBS Mappings

These menu choices are available under the MODE button the front panel (TX side).

User can select the following TX patterns as internally-generated payload:

- Fixed 00 (All-Zeros) to FF;
- $2^{23}-1$, or inverted $2^{23}-1$ per ITU-T O.181;
- $2^{31}-1$, or inverted $2^{31}-1$.

The only structured payload mappings available in SDH mode is (16 x VC-4). In SONET mode, users can select internal generated payload mapping as 1x 3 x STS-1 or 16 x STS-3c.

User can also select one of three TX patterns to fill the background of internally-generated 2.4 Gbit/s signal to which externally-supplied 155 or 622 Mbits/ signal is added (EXT mode). The user has the same background mapping selections (STS1 or STS3c in SONET, VC4 in SDH).

Payload and test patterns are compatible with ITU-T O.181.

This option will appear in both "INTERNAL" or "EXTERNAL" Transmitter modes. The first menu below (STS1, STS3c) will only appear in SONET measurement mode, since VC4 Test Pattern is the only valid option in SDH measurement mode.

The choice between the asterisks (*) is the choice that can be selected. Press the ENTER key to bring up other choices.

```

INT TX MAPPING STRUCTURE
VC4:  <1>  4C  16C
  
```

OR

```

INT TX VC4 TEST PATT
FIXED <00> *PRBS <23O181>*
  
```

OR

```

EXT TX VC4 TEST PATT
FIXED <00> *PRBS <23O181>*
  
```

Figure 3-9. PRBS Mappings (MODE button) (SDH)

Input Select, Transmitter

```

EXT TRIB INPUT SELECT
<155> 622 155e

```

Figure 3-10. Input Select Menu

The Transmitter SELECT key is used to pick one of three tributary choices when the MODE is set to EXT (external). The input can be 155 Mb/s (STM-1) optical, 622 Mb/s (STM-4) optical, or 155 Mb/s CMI electrical signal source from the appropriate connector.

Tributary Select, Transmitter

The TRIB key on the Transmitter side is used to select how the external source (tributary) will be multiplexed into the 2.4 Gb/s signal.

```

EXT 155 Mb/s TRIB INSERT
SINGLE <nn>    ALL

```

OR

```

EXT 622 Mb/s TRIB INSERT
SINGLE <n>     ALL

```

Figure 3-11. Transmitter Tributary Select Menus

A choice is offered between multiplexing the tributary into one specific channel or into all available 2.4 Gb/s channels. This menu depends on the choice that was made in the *Input Select* menu—155, 622, or 155e (CMI).

- The first menu is the 155 Mb/s tributary insert menu that is used to select between multiplexing the external source tributary into 1 of 16 channels or all 16 channels of the 2.4 Gb/s signal. It refers to both the optical and electrical (CMI) 155 Mb/s Transmitter input signals.
- The second menu is the 622 Mb/s tributary insert menu that is used to select between multiplexing the external source tributary into 1 of 16 channels or all 16 channels of the 2.4 Gb/s signal. It refers to the optical tributary source.

Illegal Mode



Figure 3- 12. Transmitter Alarms

If the TRIB or INPUT SELECT keys are pressed when the Transmitter is in the INT (internal) or THRU (through) mode, the illegal mode display will be exhibited for three seconds and then switched to the TX MODE SELECTION menu.

Alarm Generation Menus—SDH

The left column shows the four SDH alarm displays that will be scrolled in a loop each time the Transmitter alarm key is pressed. The right side shows the same alarm displays when the continuous mode is being accessed. The arrow keys, increment and decrement keys, and the Enter key are used to modify the alarm conditions and access the continuous displays.

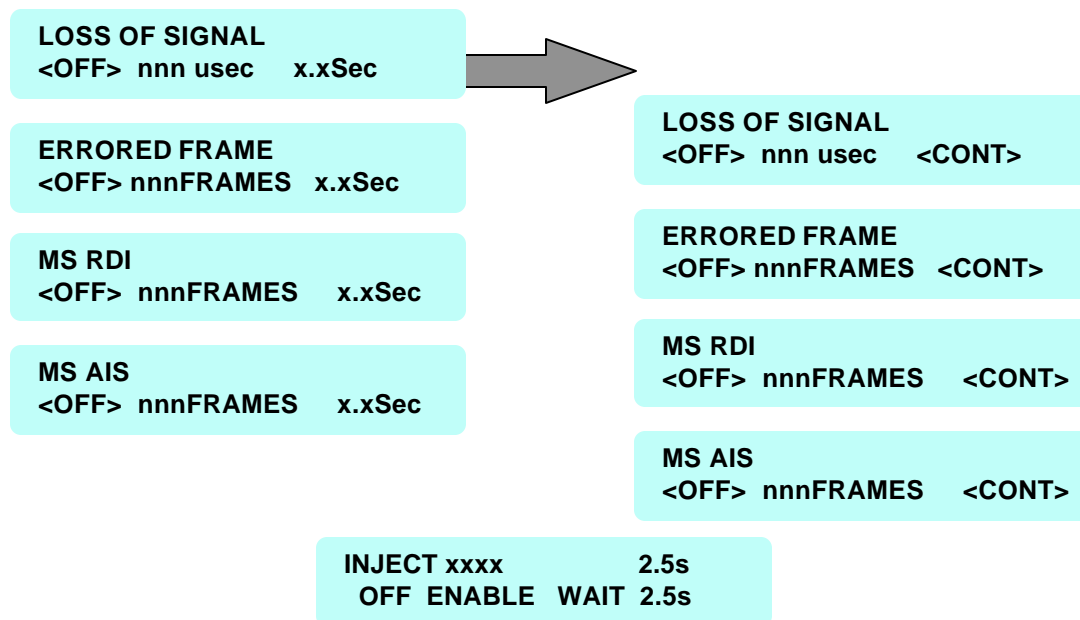

Figure 3-13. Transmitter Alarms SDH

The Transmitter ALARM key is used to select one of the five alarm menus, four on the left, and one centered at the bottom LOS (Loss Of Signal), ERRORED FRAME, MS RDI, MS AIS, and INJECT. The alarm menus are used to set specific parameters simulating various synchronization defects as detailed below.

Each of the first four Transmitter alarm menus have the following parameters:

- **OFF**—The alarm is disabled.
- **nnn μ sec (or nnn FRAMES)**: Sets the duration of the alarm in microseconds for the LOS alarm or frames for the other alarms. Position the cursor using the left and right arrow keys. Use the INC and DEC keys to change the value from 1 to 127 microseconds or frames. Press the Enter key to generate the alarm.
- **x.xSec**: Sets the on time for the burst operation from 0.1 to 9.9 seconds. This alarm condition generates extensive signal failure. Each time the Enter key is pressed an asterisk (*) and the word ACTIVE will be displayed in the upper right side of the display. Use the arrow keys to position the cursor, and the INC and DEC keys to change values. This field changes to CONT, when the value is incremented beyond 9.9 seconds. Or when the cursor positioned under the

letter S in the x.xSec and the increment key is pressed. The DEC key is used to return to this (x.xSec) value.

- **CONT:** Turns the alarm condition on continuously, generating a hard failure. To access this hidden field see x.xSec above. Pressing the Enter key will turn on the alarm continuously, displaying an asterisk (*) and the word ACTIVE. Use the right arrow key to move the cursor to OFF and the Enter key to turn the alarm off. Then use the left arrow key to move the cursor back to CONT and the Enter key to activate the alarm. Using the alarm key to leave the menu will not turn the alarm off.

The INJECT xxxx alarm menu, permits recurring alarm conditions to be set. Position the cursor under the alarm—xxxx in this case—and use the increment key to select the alarm type. Then set the alarm INJECT (on time) period from 0.1 to 9.9 seconds, and the WAIT (off time) for a period from 1.0 to 30.0 seconds. An asterisk (*) will switch between the wait and inject states, replacing the letter s, indicating which is the active state. Only one alarm condition can be activated at any one time. Enabling the recurring alarm will disable any other active alarm. Moving the cursor to OFF and pressing the Enter key will stop the alarm cycle. When off, the letter s will appear at the end of both top and bottom LCD display lines.

Overhead Menus (SDH), Transmitter

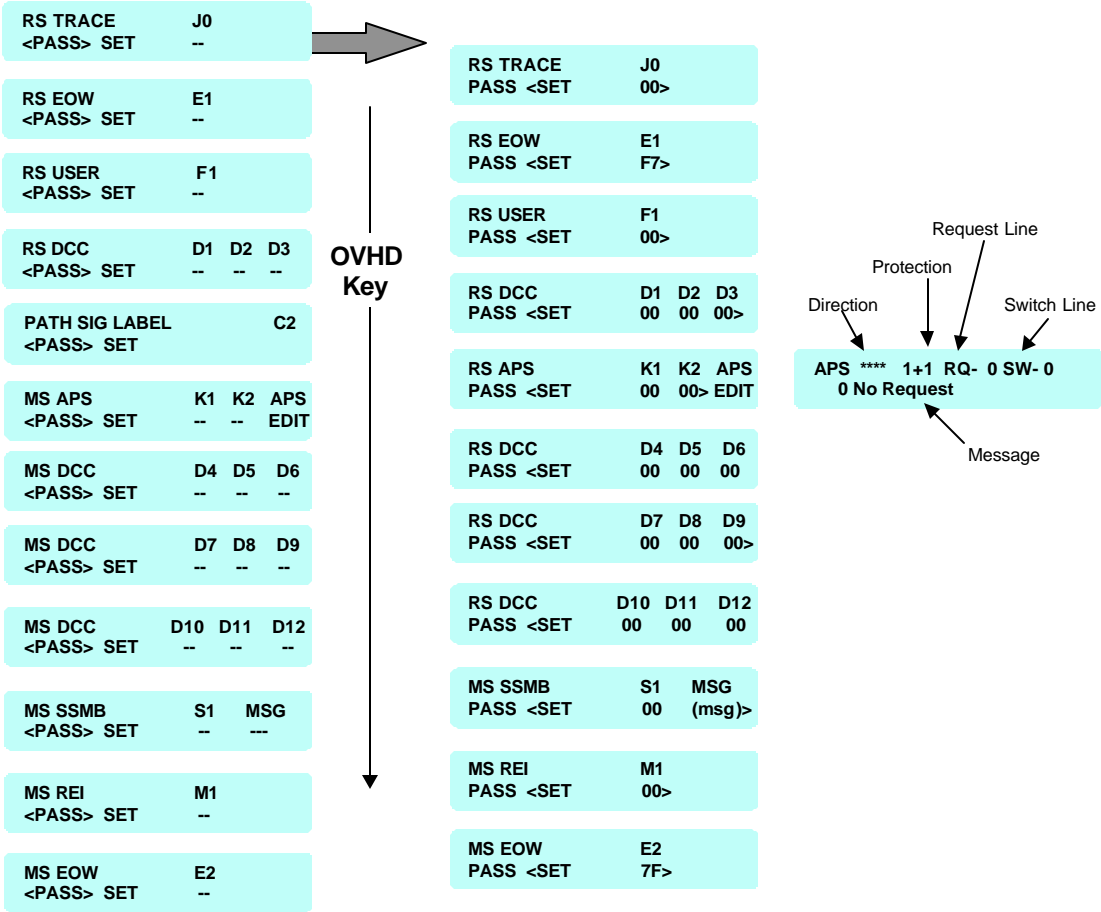

Figure 3-14. Transmitter Overhead (SDH)

The Transmitter overhead byte menus can be used to pass or change the 2.4 Gb/s signal overhead bytes, in the first column of the STM-1. The Transmitter OVHD (overhead) key is used to scroll through the Regenerator Section (RS) and Multiplexer Section (MS) overhead bytes. The top line of each display identifies the designated SDH overhead byte. The bottom line is used to either PASS or SET (change) the value. When the cursor is on PASS the byte is hidden. When the cursor is moved to SET the byte value is displayed and the Enter key LED starts to flash. Use the arrow keys to move the cursor, and the INC and DEC keys to change values. Pressing the Enter key or the overhead key will store the value.

Bytes D4 through D12 are passed or set as a group. Each can be individually changed, using the INC and DEC keys, but pressing the Enter key to SET any one of them will set all of them. Passing any one will pass them all.

For the path overhead, C2 byte is added at TX (Path Signal Label C2)) - Identifies High Order Path Label Unequipped and High Order Path Label Mismatch. C2 byte can be set to any value from 0x00 to 0xFF.

Select the EDIT command from the MS APS menu to access and change the Automatic Protection Switching bytes illustrated on the right side of the figure. Position the cursor over the word EDIT, press the Enter key and the APS menu in will be displayed. Use the arrow, INC, DEC, and ENTER keys to select, change, and store values. Press the OVHD key to return to the MS APS menu.

Ability to edit J0 Multi-Byte Trace

J0 Trace Generation (TX); Capture & Display (RX)

J0 Trace provides a capability to uniquely identify each of the multiple channels being carried in a Dense Wave Division Multiplexer (DWDM) system, providing an end-to-end continuity check. Since only the SONET framing byte plus J0 are in the unscrambled overhead of the SONET signal, it is possible to extract for display the J0 trace to confirm channel ID.

ST2400A ability to generate unique J0 traces allows test signals to be easily identified, or allows test signals to simulate network-element generated traffic without Trace Identifier Mismatch (TIM) alarm being generated. ST2400A ability to display received J0 trace allows users to verify continuity and correct routing of individual channels within multi-channel DWDM system.

ITU-T has established a standard for 16-byte J0 trace. GR-253 has no multi-byte J0 standard, but J0 Trace is listed as an open issue in most recent List Report (GR-253-ILR, Issue 2B, Dec 97). Some vendors are promoting 64-byte trace matching SONET J1 trace standard in GR-253-CORE.

ST2400A ability to generate non-standard-compliant 16-byte and 64-byte traces allows manufacturers to test network element response in presence of invalid trace (for example, 16-byte without valid frame start marker or with incorrect CRC; 64-byte without <CR><LF> termination).

J0 Trace Generation (TX)

When single-byte SET selected, user may set the value of J0 byte between 0 and 255. Factory default is 01.

When 16-byte SET selected, the first byte is set to frame start marker containing CRC-7 calculated over the 15 remaining bytes per ITU-T G.707 section 9.2.2.2. User is able to view/edit the CRC and the ASCII contents of the remaining 15-bytes. Factory default is valid frame start marker followed by "Tek ST2400A<4 NULLs>". 16-byte trace value is saved in non-volatile memory and restored on power-up (to eliminate need for users to always go through a cumbersome process to set it up).

When 64-byte SET selected, user is able to set the J0 trace per the requirements of GR-253-CORE for J1 traces (Issue 2, Dec 1995, section 6.2.3.2.3.A, STS Path Trace). User is able to set all 64 bytes to any hex value from 00-FF. If the user enters less than 62 characters, the ST-2400A shall pad the remainder with NULL characters. A <CR> and a <LF> is added to the end of the message, creating the 64-byte trace message. Factory default 64-byte trace message is "Tek ST2400A<51 nulls><CR><LF>". 64-byte trace value is saved in non-volatile memory and restored on power-up.

J0 Generation Front Panel Implementation

Allow user to PASS J0 through, SET it to single byte hex value, set it to 16Byte value, or set it to 64Byte value as shown:

SECT TRACE	J0
<PASS> SET	nn EDIT

When PASS is selected, and TX is in EXT mode, J0 in received added tributary is inserted in J0 of output 2.5 Gb/s signal.

When PASS is selected and TX is in THRU mode, J0 in received 2.5 Gb/s signal is retransmitted in J0 of output 2.5 Gb/s signal.

When PASS is selected and TX is in INT mode, J0 is set to single byte 01.

When “SET nn” is selected, nn should display currently selected single byte J0 as two hex digits. User may set single byte J0 to any value in range 0 - 255 (00 - FF hex).

When “EDIT” is selected and ENTER is pressed, user is able to select between 16-byte ITU-formatted trace, and 64-byte trace as shown below:

J0 TRACE SELECTION
<16 BYTE> 64 BYTE

When 16-byte trace is selected, 15 editable bytes of 16-byte trace are set to first 15 bytes of trace in memory. If 16-byte trace was most recently used, previous trace is restored. If 64-byte trace was most recently used, these 15 bytes are set to first 15 bytes of previously used 64-byte trace. Correct frame start marker is computed and displayed in hex in “nn” portion of CRC-nn.

Factory default trace is “Tek ST2400A<4 NULLs>”.

When CLR is selected, 15 editable bytes of 16-byte trace is cleared to null (hex 00), and correct frame start marker is computed and displayed in hex in “nn” portion of CRC-nn.

When trace characters are selected, left arrow, right arrow, INC, DEC, and ENTER are used to navigate trace and edit characters. Full set of upper case, lower case, digits, and punctuation is selectable. The hexadecimal equivalent of each character selected on the second row will be updated in the “HEX=” field on the first row, as shown below.

If the character being edited on the second row is less than 0x20 hex or greater than 0x7F hex, the character will be displayed as a filled in box in the center of the field, the correct value will still be displayed in the “HEX=” field.

16 BYTE <EDIT> CLR HEX=54
TEK ST2400A CRC=F4

When 64-byte trace is selected, 62 editable bytes of 64-byte trace are set to bytes stored in 64-byte trace memory. Last two bytes are set to <CR><LF>. Factory default trace is “Tek

When CLR is selected, 62 editable bytes of 64-byte trace are cleared to nulls (hex 00), and <CR><LF> is placed in last two characters.

When trace characters are selected, left arrow, right arrow, INC, DEC, and ENTER are used to navigate trace and edit characters. If trace contains non-printable ASCII characters, those characters are displayed as a filled in box.

When cursor is in right-most character position and right arrow key is pressed, trace is shifted left so character and cursor – previously in right-most character position – now appear in left-most character position, with 21 following characters displayed in remaining positions. As shown below, arrow indicator is displayed in left-most and/or right-most display position when preceding or following trace characters are available to be displayed by scrolling left or right:

← 64 BYTE <EDIT> CLR HEX=54
→
ST2400A

J0, J1 Trace Capture and Display (RX)

ST-2400A is able to capture J0 and J1 trace on a sampled basis for display. User is able to select the expected trace length / type as single-byte, 16-byte, or 64-byte. When trace display is selected, J0 trace is sampled and display updated at least four times per second.

16-byte trace selection shall expect 16-byte trace matching format specified in G.707 / G.831. Trace is displayed either as 15-byte ASCII string, or as hex value of frame start marker followed by 15-byte ASCII string. ST-2400A must recognize frame start marker and display 15-ASCII characters in sequence, assuming identical 16-byte trace is being repetitively received.

No CRC error detection capability is provided in 16-byte trace mode.

64-byte trace selection expects 64-byte trace matching format specified for STS Path Trace in GR-253-CORE (as described above for TX). Trace is displayed as 64 byte ASCII string (with <CR><LF> indicated as their Hexadecimal values).

No Trace Identifier Mismatch (TIM) detection is provided in single-byte, 16-byte or 64-byte trace mode.

J0, J1 Trace Capture and Display Front Panel Implementation (RX)

ST2400A displays single byte J0 and J1, as shown below:

RX TOH	A1	A2	J0	J1
	F6	28	01	00

If multi-byte trace is received, J0 and J1 can be expected to change frequently, when single byte display is selected.

The J0 and J1 trace selection menus are the last menus in the queue of RX overhead menus. User is able to select between display of 16-byte or 64-byte trace, as follows:

J0 TRACE SELECTION
<16 BYTE> 64 BYTE

J1 TRACE SELECTION
<16 BYTE> 64 BYTE

When 16-Byte is selected (as shown above), frame start marker (if found, based on detection of character with MSB set) is displayed in hex, along with 15-byte ASCII trace. Non-printable characters are displayed as boxes (). If a frame start marker is found, the trace will be aligned and 16 captured bytes are displayed in captured order, as follows:

The left and right arrow keys can be used to scroll forward / backward through the 16 byte trace and the CRC, the "HEX=" will be properly updated.

```
16 BYTE <EDIT> CLR HEX=54
TEK ST2400A          CRC=F4
```

When 64-Byte is selected (as shown below), first 22 characters following <CR><LF> is displayed as shown. Non-printable characters is displayed as boxes (). If no<CR><LF> can be found, captured 64 bytes are displayed in captured order with no error indication. NOTE: Subsequent display updates will likely cause frequent trace content changes if no valid trace containing CR / LF can be found.

```
← 64 BYTE <EDIT> CLR HEX=54
→
TEK ST2400A
```

User is able to use left and right arrow keys to scroll forward / backward through 64-byte trace.

NOTE: At the end of a valid 64byte trace, in the 63rd and 64th positions the <CR> and <LF> will be represented in the "HEX=" field as 0D and 0A respectively.

Ability to edit M1 Byte

MS-REI	M1
<PASS> SET	00

Figure 3-15. Transmitter Overhead (OVHD button) (SDH)

The Transmitter overhead byte menus can be used to pass or change the 2.4 Gb/s signal overhead bytes, in the first column of the STM-1. The Transmitter OVHD (overhead) button, on the lower left side of the ST2400A front panel, is used to scroll through the Regenerator Section (RS) and Multiplexer Section (MS) overhead bytes. The top line of each display identifies the designated SDH overhead byte. The bottom line is used to either PASS or SET (change) the value. When the cursor is on PASS, the byte is hidden. When the cursor is moved to SET the byte value is displayed and the Enter key LED starts to flash. Use the arrow keys to move the cursor, and the INC and DEC keys to change values. Pressing the Enter key or the overhead key will store the value. The value of the editable M1 byte can range from 00 to FF.

Error Generation Menus (SDH)

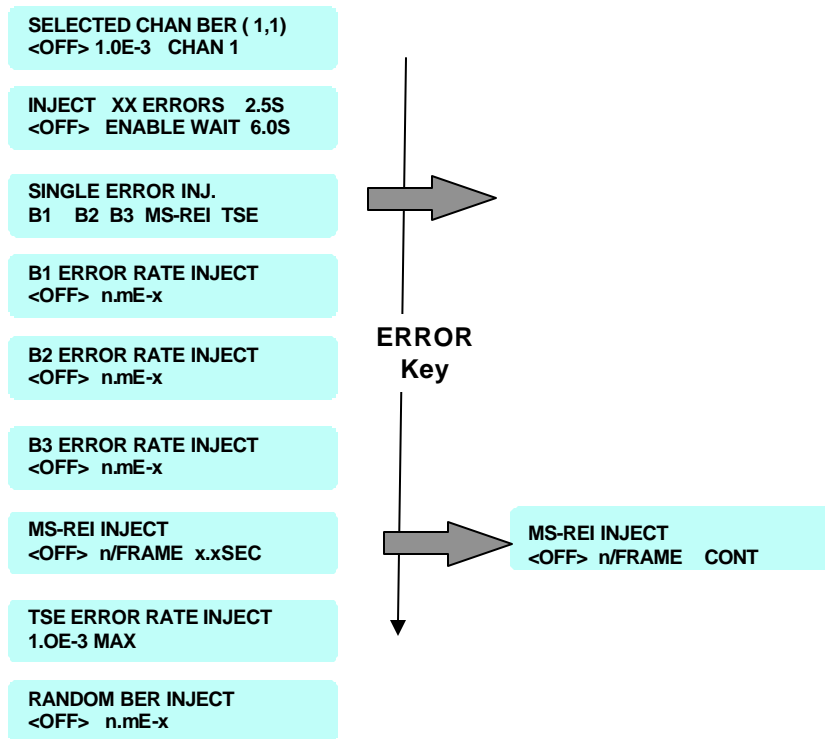

Figure 3-16. Transmitter Error Generation (SDH)

Pressing the Transmitter ERROR key will scroll through the main menus shown. The arrow keys are used to move the cursor when selecting menu items. The INC and DEC keys are used to change values. The ENTER key is used to execute the function. Enabling any error will disable all other active errors.

The first menu, **SINGLE ERROR INJ**, is used to inject one error each time the Enter key is pressed. Use the arrow keys to positioning the cursor over the B1, B2, B3, MS-REI, TSE and press the ENTER key to generate that error.

The error key is pressed again to obtain the **B1, B2 or B3 ERROR RATE INJECT** menu. Use the arrow keys to move the cursor to n.mEx and the INC and DEC keys to set the error rate. Pressing the Enter key will inject the B1 or B2 error at that rate, continuously. The B1 rate is inserted as a negative exponent from 2.5E-5 to 0.1E-9. The B2 rate is inserted as a negative exponent from 1.0E-3 to 0.1E-9. The maximum B3 rate is 1.0E-4. The Max. rate for Payload Bit Error Injection is 1.0E-3. An error rate of 1.0E-6 would equate to the decimal number derived from sending one errored bit in a million bits. In other words, one divided by one million would equal 0.000001 or 1.0E-6 decimal.

The **MS-REI INJECT** menu has three functions:

- A number of MS-REI errors can be injected into one frame. The ERROR key is used to select the menu, and the arrow keys are used to position the cursor over the n/FRAME (n per frame) field. The number of MS-REI errors per frame can be set from 1 to 255 using the INC and DEC keys. Pressing the Enter key while this field is selected will insert that number into a single frame.
- Move the cursor to x.xSEC and use the INC and DEC keys to set the period from 0.1 to 9.9 seconds. Pressing the ENTER key when the cursor is in the x.xSEC position will inject the number of MS-REI errors (n/FRAME) for the period (x.xSEC), effecting multiple frames. For example, one MS-REI per frame could be injected for 9.9 seconds. An asterisk and the word *ACTIVE* will be displayed for the duration of the MS-REI injection.
- Moving the cursor under the letter *s* in x.xSec or pressing the INC key when the period is set to 9.9 seconds will access the CONT (continuous) command, shown on the lower right side of the figure. Positioning the cursor over CONT and pressing the Enter key will insert the number of MS-REI (n/FRAMES), continuously. An asterisk and the word *ACTIVE* will be displayed indicating that the error is being injected. Use the right arrow key to move the cursor to OFF and press ENTER. The asterisk and the word *ACTIVE* will no longer be displayed, indicating the error injection is off.

The **RANDOM BER (Bit-Error-Rate) INJECT** main menu is used to set the rate to a number from 1.0E-3 to 0.1E-9. Pressing the Enter key will inject errors at that rate on different STM-16 channels, selected at random.

The **Selected Channel BER** (Bit Error Rate) main menu is used to set the rate to a negative exponent from 1.0E-3 to 0.1E-9 for the CHAN (channel) selected. Positioning the cursor over the selected channel (CHAN cc) in the lower right field and use the INC and DEC keys to select the STM-1 channel number.

The **INJECT XX ERROR** menu, permits recurring error conditions to be set. Position the cursor under the XX and use the INC key to select the error type. The INJECT period (on time) is located in the top right field, 2.5S in this case. It can be set from 0.1 to 9.9 seconds. The WAIT period (off time) is in the lower right field, 6.0S in this case. It can be set from 1.0 to 30.0 seconds. The rates are set in each individual menu, B1, B2, B3, MS-REI, RANDOM BER, and CHANxx BER. An asterisk (*) will switch between the wait and inject states, indicating which is active. Only one error condition can be activated at any one time.

NOTE: Bit Error Rates are inserted as a negative exponent. An error rate of 1.0E-6 would equate to the decimal number derived from sending one errored bit in a million bits. In other words, one divided by one million would equal 0.000001 or 1.0E-6 decimal.

B2 or B3 Error Inject (Single, All channels simultaneously)

This menu choice is available under the ERROR button on the front panel (TX side).

The user of this test unit can inject a single B1 or B2 error (one B1 or B2 error in fixed channel of 2.4 Gbit/s payload), or the user can inject B1 or B2 errors simultaneously in all channels of 2.4 Gbit/s payload. B2 error rates may be generated over the range 1.0E-3 to 0.1E-9.

SINGLE ERROR INJECT B1 <B2> B3 MS-REI TSE
--

B2 ERROR RATE INJECT <OFF> 1.0E-5
--

B3 ERROR RATE INJECT <OFF> 1.0E-4 MAX.

The following are contained in one menu.

INJECT B2 ERRORS	2.5 s
<OFF> ENABLE WAIT	1.0 s

INJECT B3 ERRORS	2.5 s
<OFF> ENABLE WAIT	1.0 s

INJECT TSE	2.5 s
<OFF> ENABLE WAIT	1.0 s

Figure 3-17. Transmitter Error Generation (ERROR button) (SDH)

Pressing the Transmitter ERROR key on the lower left side of the ST2400A front panel will scroll through the available menus. The arrow keys are used to move the cursor when selecting menu items. The INC and DEC keys are used to change values. The ENTER key is used to execute the function. Enabling any error will disable all other active errors.

The SINGLE ERROR INJ menu, is used to inject one error each time the Enter key is pressed. Use the INC key to position the cursor over the B1, B2, FEBE-L, BIT, or CH (Channel), and press the ENTER key to generate that error. When the cursor is positioned over B1, press the INC key again to change to the B2 byte.

The next menu permits injecting a single B2 error into all channels.

Press the ERROR key to move to the next menu, B2 ERROR RATE INJECT. Use the arrow keys to move the cursor to **1.0E-5** and the INC and DEC keys to set the error rate. Pressing the Enter key will inject the B2 error at that rate, continuously.

Inject Random BER on one Selectable Channel

This menu choice is available under the ERROR button on the front panel (TX side).

The user of this test unit can inject a random bit error rate on one selectable channel.



```
SELECTED CHAN BER ( 1,1)
<OFF> 1.0E-3 CHAN 1
```

Figure 3-18. Random BER on one Selectable Channel (ERROR button) (SDH)

Receiver Menus and Displays

Error Measurements (SDH), Receiver

Press ENTER key again and again to cycle through the choices.

RS-B1 Measurement

RS	ES =	0	BER = 1.0e-04
B1	SES =	0	TOT = 0

The Enter key will flash while at the menu above. Pressing the Enter key permits access to the following sub-menus.

RS	EB =	0	CSES	0
B1	BBE =	0		

RS	BBER	ESR =	0.0E-00
B1	0.00E-00	SESR =	0.0E-00

RS	AEB =	0	AES =	0
B1	ABBE =	0	ASES =	0

RS	UAS =	0		
B1	UR =	0.0E-00		

MS-B2 Measurement

MS	ES =	0	BER = 1.0e-04
B2	SES =	0	TOT = 0

The Enter key will flash while at the menu above. Pressing the Enter key permits access to the following sub-menus.

MS	EB =	0	CSES	0
B2	BBE =	0		

MS	BBER	ESR =	0.0E-00
B2	0.00E-00	SESR =	0.0E-00

MS	AEB =	0	AES =	0
B2	ABBE =	0	ASES =	0

MS	UAS =	0
B2	UR =	0.0E-00

HP-B3 Measurement

HP	ES =	0	BER = 1.0e-04
B3	SES =	0	TOT = 0

The Enter key will flash while at the menu above. Pressing the Enter key permits access to the following sub-menus.

HP	EB =	0	CSES	0
B3	BBE =	0		

HP	BBER	ESR =	0.0E-00
B3	0.00E-00	SESR =	0.0E-00

HP	AEB =	0	AES =	0
B3	ABBE =	0	ASES =	0

HP	UAS =	0
B3	UR =	0.0E-00

MS-REI Measurement

MS	ES =	0	BER =	1.0e-04
REI	SES =	0	TOT =	0

The Enter key will flash while at the menu above. Pressing the Enter key permits access to the following sub-menus.

MS	EB =	0	CSES	0
REI	BBE =	0		

MS	BBER		ESR =	0.0E-00
REI	0.00E-00		SESR =	0.0E-00

MS	AEB =	0	AES =	0
REI	ABBE =	0	ASES =	0

MS	UAS =	0		
REI	UR =	0.0E-00		

HP-REI Measurement

HP	ES =	0	BER =	1.0e-04
REI	SES =	0	TOT =	0

The Enter key will flash while at the menu above. Pressing the Enter key permits access to the following sub-menus.

HP	EB	0	CSES=	0
REI	BBE	0		

HP	BBER		ESR =	0.0E-00
REI	0.00E-00		SESR =	0.0E-00

HP	AEB =	0	AES =	0
REI	ABBE =	0	ASES =	0

HP	UAS =	0		
REI	UR =	0.0E-00		

TSE Measurement

TSE	ES =	0	BER =	1.0e-04
	SES =	0	TOT =	0

The Enter key will flash while at the menu above. Pressing the Enter key permits access to the following sub-menus.

TSE	EB	0	CSES=	0
	BBE	0		

TSE	BBER	0.00E-00	ESR =	0.0E-00
			SESR =	0.0E-00

TSE	AEB =	0	AES =	0
	ABBE =	0	ASES =	0

TSE	UAS =	0		
	UR =	0.0E-00		

Totals

RS-B1	MS-B2	HP-B3
0	0	0

MS-REI	HP-REI	TSE
0	0	0

ELAPSED TIME
D HH:MM:SS

The ERROR key on the Receiver side of the front panel is used to scroll through the LCD displays on the left side. The Enter key on the right side of the LCD display is used to access a set of submenus for each of the first three main menus—RS-B1, MS-B2, HP-B3, MS-REI, HP-REI, and TSE Measurement. Errors that were detected on the 2.4 Gb/s SDH signal are displayed in the RS-B1, MS-B2, and HP-B3, MS-REI, HP-REI, and TSE error summary menus. These errors are totaled in the fourth menu. The last menu on the lower left will display the elapsed test time in: days, hours, minutes, and seconds. Each press of the error key will cycle to the next error display in a continuous loop, until some other key is pressed.

Error Measurement Details

- **Error Reporting** - In both SONET and SDH mode, the ST2400A will provide Total Errors, Errored Seconds (ES), bit error rate (BER) and Severely Errored Seconds (SES). for B1, B2, B3, FEBE-L (MS-REI), FEBE-P (HP-REI) and Payload Bit (TSE) errors. In SDH mode, the ST2400A will provide Errored Blocks (EB) and Background Block Errors (BBE) for G.826 error analysis measurement. In SDH mode, the ST2400A will properly detect and count Consecutively Severely Errored Seconds (CSES) per G.826. In SONET mode, Severely Errored Seconds (SES) will be counted based on SES criteria in GR-253-CORE. Consecutively Severely Errored Seconds will be measured for B1, B2, B3 and MS-REI errors, and displayed in SDH mode only.
- In SDH mode, all overhead, alarms, failures, and errors are displayed or printed in ITU-T terminology (for example, FEBE is REI, FERF is RDI, etc.).
- The RS-B1, MS-B2, HP-B3, MS-REI, HP-REI and TSE summary menus include: the EB (Errored Blocks) which is the error count; the BBE (Background Block Errors); the ES (Errored Seconds); and the SES (Severely Errored Seconds). These measurements conform to the ITU G.826 standard.
- The submenu BBER (Background Block Error Ratio); ESR (Errored Seconds Ratio); and SESR (Severely Errored Seconds Ratio) conforms to the ITU G.826 standard.
- The submenu AEB, ABBE, AES, and ASES, are the Errored Blocks; Background Block Errors; Errored Seconds; and Severely Errored Seconds counted during Available time—conforming to the ITU M.2101 standard.
- The menu UAS (Unavailable Seconds) count and UASR (Unavailable Seconds Ratio) conform to the ITU G.827 standard.

G.826 and M.2101 Measurements in SDH Mode

In SDH mode, the following measurements are calculated for each of the B1, B2, and MS-REI error types:

TOT (Total Errors) Total number of errors detected since testing was started (or restarted).

BER (Bit Error Ratio) Ratio of number of errors detected to the number of bits monitored for errors since testing was started (or restarted). (Computed only for B1, B2 errors; Not computed for MS-REI errors.). HP-REI ES can occur with HP-RDI.

ES (Errored Seconds) Number of seconds since testing was started (or restarted) in which one or more errors were detected. B3 ES can occur with LOP or Path AIS.

SES (Severely Errored Seconds) Number of seconds since testing was started (or restarted) in which the number of detected errors exceeded the severely errored second threshold or in which a relevant defect was detected. Relevant defects are: LOS (all SES), LOF (all SES), MS-AIS (B2 and MS-REI SES only), and MS-RDI (MS-REI SES only). SES threshold is currently set to 30% of the blocks (SDH frames) per second for B1, B2, and MS-REI errors. (Thresholds

follow G.826 recommendation, but do not conform to draft new recommendation G.826, “Error Performance Events for SDH Multiplex and Regenerator Sections”, which recommend 30% threshold for B1 errors, but 15% threshold for B2 and MS-REI errors.)

CSES (Consecutive Severely Errored Seconds) Count of Consecutive Severely Errored Second periods. A CSES period is defined as a period of more than 2, but less than 10, consecutive SES.

EB (Errored Blocks) The number of SDH frames in which one or more errors of the selected type were detected since testing was started (or restarted). SDH frames occur at a rate of 8000 per second. Per ITU-T G.826, Errored Blocks should count one EB for each frame in which one or more errors are detected, but may count the total number of errors detected per frame (see G.826 C.1.5). The ST-2400 and ST-2400A count EBs as the total number of errors detected.

BBE (Background Block Errors) The number of errored blocks not occurring during SES or Unavailable time.

BBER (Background Block Error Ratio) The ratio of Background Block Errors (BBE) to total blocks in available time since testing was started (or restarted). The count of total blocks excludes all blocks during SESs.

ESR (Errored Second Ratio) The ratio of Errored Seconds (ES) to total seconds in available time since testing was started (or restarted).

SESR (Severely Errored Second Ratio) The ratio of Severely Errored Seconds (SES) to total seconds in available time since testing was started (or restarted).

AEB (Available Errored Blocks) Number of Errored Blocks (EB) counted during available time.

ABBE (Available Background Block Errors) Number of Background Block Errors (BBE) counted during available time.

AES (Available Errored Seconds) Number of Errored Seconds (ES) counted during available time.

ASES (Available Severely Errored Seconds) Number of Severely Errored Seconds (SES) counted during available time.

UAS (Unavailable Seconds) The number of seconds during which error performance was such that the received signal was deemed to be unavailable (see definition of available and unavailable time below).

UR (Unavailable Seconds Ratio) The ratio of unavailable seconds to total time since testing was started (or restarted).

Definition of Available and Unavailable Time (per G.826) Received signal becomes unavailable when 10 consecutive severely errored seconds are detected. The 10 consecutive SES required to enter the unavailable state are considered unavailable seconds. The signal remains in the unavailable state until 10 consecutive non-severely errored seconds are detected. The 10 consecutive non-severely errored seconds are considered part of the available time.

Overhead Displays (SDH), Receiver

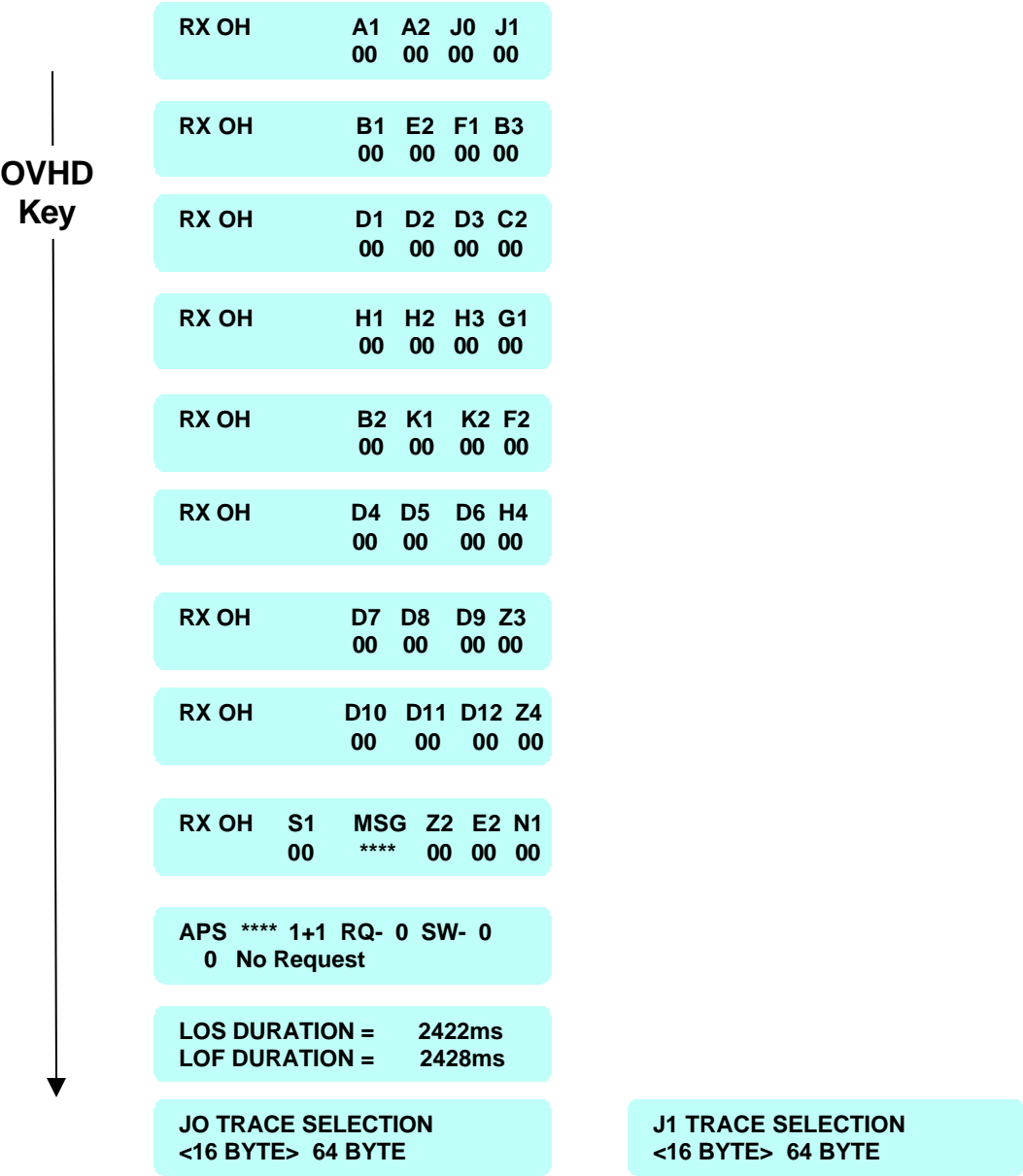

Figure 3-19. Receiver Overhead LCD Displays

The ten displays are RX OH SDH overhead bytes in the first column of the first STM-1 frame. They can be displayed by pressing the OVHD key on the Receiver panel. Each time the key is pressed the next group of overhead bytes will be displayed in a continuous loop, until some other key is pressed.

There are nine displays of four bytes each. The ninth display provides the ASCII synchronization messages, the tenth display is the APS message, the eleventh display shows the amount of time, in microseconds, of the Loss of Signal (LOS) and Loss of Frame (LOF), and the twelve and thirteenth displays permit J0 and J1 trace selection menus with selection of 16 byte or 64 byte trace.

B3 path trace capability adds the following bytes: J1; B3; C2; G1; F2; H4; F3; K3; and, N1. These overhead bytes are only displayed with the B3 path trace capability.

ASCII Synchronization Messages—S1 byte

For convenience both the SONET and SDH modes are compared below. The S1 byte is in hexadecimal. The unused SONET values are left blank. The unknown SDH value is marked with three question marks and unused codes are marked RES (reserved).

S1 Byte	SONET	SDH	S1 Byte	SONET	SDH
00	STU	???	08		812L
01	PRS	RES	09		RES
02		811	0A	ST3	RES
03		RES	0B		SETS
04		812T	0C	SMC	RES
05		RES	0D		RES
06		RES	0E	RES	RES
07	ST2	RES	0F	DUS	DNU

S1 Byte/ SSM - ST2400A includes S1 byte changes as events which can initiate print-on-event. When Synchronization Status Message (SSM) in S1 byte changes, a time-stamped report of SSM can be printed indicating new SSM contents.

SSM byte changes are decoded in clear text per G.707 (SDH) and GR-253 (SONET).

Automatic Protection Switching (APS)

From the top line: The direction can be UNI (unidirectional), BI (bi-directional), REI (Remote Error Indication), AIS (Alarm Indication Signal), or four asterisks (****) indicating none of the four line types. The Protection can either be 1+1 (one-to-one) or 1:N (several unallocated lines specified by the number N). The Request Line (the line requesting to be switched) and the Switch Line (the line that the Request Line wants to switch to) can be any decimal number from 0 to 15.

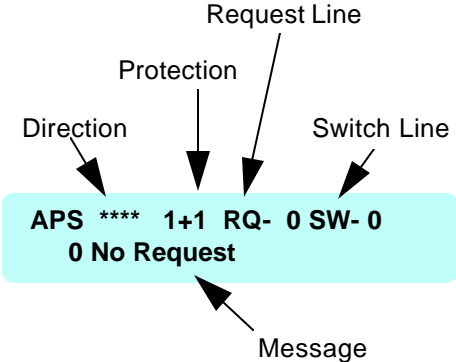

Figure 3-20. Automatic Protection Switching (APS)

The bottom line of the APS will display one of sixteen possible messages:

0	No Request	8	Manual Switch
1	Do Not Revert	9	(Not used)
2	Reverse Request	10	SD-Lo Priority
3	(Not used)	11	SD-Hi Priority
4	Exercise	12	SF-Lo Priority
5	(Not used)	13	SF-Hi Priority
6	Wait To Restore	14	Forced Switch
7	(Not used)	15	Lockout Protect

Receiver Tributary Select (SDH)

The TRIB key is used to select which tributary will be dropped out of the 2.4 Gb/s (STM-16) signal. One of sixteen 155 Mb/s (STM-1) tributaries or one of four 622 Mb/s (STM-4) tributaries can be selected using the front panel increment and decrement keys. This display depends on which drop was selected in the *RX DROP SELECT* or *SDH QUICK SETUP* menu—off, 155, or 622. The two possible SDH menus are shown below.

155 Mb/S RX DROP TRIB STM-1 #nn
--

OR

622 Mb/s RX DROP TRIB STM-4 #n

Figure 3-21. Receiver Tributary Select Menus

- The first menu is the SDH 155 Mb/s tributary select menu used to select 1 of 16 tributaries.
- The second menu is the SDH 622 Mb/s tributary select menu used to select 1 of 4 tributaries.

Receiver Tributary - RX Channel Selection (SDH)

The Receiver side TRIBUTARY key is also used to select the Mapping and Structure of the RX Channel Selection. When a valid signal is present, the menu below will auto-detect the proper mapping and first valid channel. The mapping and channel will be displayed in the appropriate column. If several types of mapping are present, the user can select any valid mapping present in the signal. The menu will only display mapping and channels that are valid.

When using remote commands to set up mapping and channels, it is possible to select an invalid mapping or channel. Care must be taken to match the receiver mappings and channels to the ones available from the ST2400A receiver. If an invalid mapping is detected, a menu will flash on the LCD screen of the test unit. When a valid mapping is detected, the invalid mapping menu will disappear.

RX CHANNEL SELECTION VC-4C CHANNEL < 1 >
--

The number of channels available for selection are auto-detected.

STM-0 - Selection of up to 48 channels (RX only)

VC-4 - Selection of up to 16-channels.

VC-16c -- Selection of 1 channel.

VC-4c -- Selection of 4 channels.

RX VC4-4C TEST PATTERN FIXED 00 *PRBS <230181>*
--

PRBS 31 per ITU-T O.151 and 31 Inverted per ITU-T O.181

Pointers Information from Receiver Tributary key (SDH)

Keep track of all pointer movements during a test period. Pointer measurements can be found among the menus that can be accessed by pressing the TRIB key on the RX side of the ST2400A test unit. This is a Read-only screen.

RX	PJR	+PJ	-PJ	NDF
SPE: 88	5461	3919	799	

Receiver Drop Select

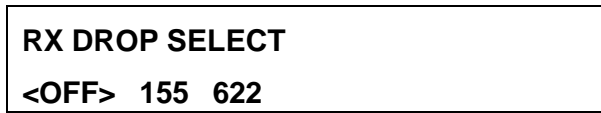

Figure 3-22. Receiver Drop Select Menu

Press the Receiver DROP SELECT key to access the menu shown in the figure above. Use the arrow and Enter keys to select one of the three choices. OFF will drop a 155 Mb/s electrical signal to the CMI connector and disable the optical drop. The 155 Mb/s (STM-1) optical drop or the 622 Mb/s (STM-4) optical drop can be selected by choosing either the 155 or 622, respectively. The 155 or 622 LED on the Receiver section of the front panel will indicate which drop is selected—both are off when the 155 CMI is selected. This menu is used with the *Receiver Tributary Select* menus.

 **WARNING!**

Before activating the 2.4 Gb/s LASER, its output must be connected to a circuit. Always replace the screw caps when the optical outputs are not in use.

Appendices

Specifications, SDH

Temperature Ranges

Operating Temperature: 0 to 40 degrees Centigrade

Storage Temperature: -20 to 60 degrees Centigrade

ST-2400A shall operate over temperature range 0 to 31 °C with relative humidity ≤ 80% non-condensing and up to 40 °C with a relative humidity ≤ 50% non-condensing.

ST-2400A should operate following storage at temperatures ranging from -20 to 60 °C with relative humidity ≤ 90% non-condensing.

Dimensions and Weight

Approximately 4.5" (11.6 cm) H x 14.5" (37.2 cm) W x 17.5" (44.9 cm) D

The weight is 25 pounds (11.4 kilograms) maximum.

Power

Voltage Requirements: auto-ranging 110 (90 to 135) VAC or
220 (180 to 270) VAC, 47-63 Hz

Power Consumption: 250 watts maximum

Fuses

The AC power module is located in the lower left-hand corner of the rear panel. It has a removable fuse panel that can be opened with a small flat blade screw driver after the AC Line Cord has been unplugged. The AC power supply automatically detects and switches to accept either 115 (90 to 130 VAC or 230 (180 to 250) VAC inputs. A 5AT fuse is used with either AC source voltage.

Year 2000 Compliant

The ST2400A may need minor manual intervention to continue functioning after the Year 2000 cross-over, for example, resetting the date. The ST2400A will not corrupt data, lose stored setups or lose functionality such as the ability to trigger, capture and manipulated data as a result of rollover event before a fix is implemented. Incorrect date generation, storing, recording, storing or processing may occur after rollover until the user implements the recommended fix, for example, resetting the date.

Safety Certification Compliance

Category	Standard
Temperature (operating)	0°C to +40°C
Altitude (maximum operating)	2000 meters
Equipment Type	Test and Measuring
Safety Class	Class I (as defined in IEC 1010-1, Annex H) - grounded product
Overvoltage Category	Overvoltage Category II (as defined in IEC 1010-1, Annex J)
Pollution Degree	Pollution Degree 2 (as defined in IEC 1010-1). Note - Rated for indoor use only.

Product Compliance Approval

Category	Standard
EC Declaration of Conformity -	<p>Compliance was demonstrated to the following specification as listed in the Official Journal of the European Communities:</p> <p>EC Council Directive 89/336/EC</p> <p>AS/NZS 2064, Australian emission standard for Industrial, Scientific, and Medical Equipment</p>

Safety Standards

Category	Standard
Low Voltage	<p>Low Voltage Directive 73/23/EEC</p> <p>EN61010-1/A1 - Safety Requirements for Electrical Equipment for Measurement, Control, and Laboratory Use.</p>
Underwriters Laboratory Approval	UL 1244 - Electrical and Electronic Measuring and Testing Equipment
Canadian Certification	CAN/CSA-22.2 No. 231 - Safety Requirements for Electrical Equipment for Measurement, Control and Laboratory Use

Transmitter (Generator) Specifications

155 Mb/s External Add Modes

These modes are valid when generating output 2.488 Gb/s signal from externally added 155 Mb/s optical or electrical (CMI) inputs. 2.488 Gb/s output signal timing is derived from externally added 155 Mb/s input so no pointer adjustments are required or generated.

155 All (Replicate) Mode

Data: 2.488 Gb/s output is made from 16 copies of the user-selected incoming 155 Mb/s optical or electrical data.

155 Single Channel Mode

Data: 2.488 Gb/s output is made from 1 copy of the selected incoming 155 Mb/s optical or electrical data in a user selected channel. The remaining 15 channels are filled with unequipped VC4-structured STM-1s bulk-filled with the user-selected test pattern (all-zeros, PN23, or inverted PN23 [ITU-T O.181 test pattern]).

622 Mb/s External Add Modes

These modes are valid when generating output 2.488 Gb/s signal from externally added 622 Mb/s optical input. 2.488 Gb/s output signal timing is derived from externally added 622 Mb/s input so no pointer adjustments are required or generated.

622 All (Replicate) Mode

Data: 2.488 Gb/s output is made from 4 copies of the 622 Mb/s incoming data.

622 Single Channel Mode

Data: 2.488 Gb/s output is made from 1 copy of the incoming 622 Mb/s data in a user selected channel. The remaining 3 STM-4 channels are each filled with 4 copies of an unequipped VC4-structured STM-1 bulk-filled with the user-selected test pattern (all-zeros, PN23, inverted PN23 [ITU-T O.181 test pattern], PN31, or inverted PN31).

Internal Mode

This mode requires no external test equipment to generate a valid 2.488 Gb/s output.

- Data: 2.488 Gb/s output is made with 16 channels of unequipped VC4-structured STM-1s bulk-filled with the user-selected test pattern (all-zeros, PN23, inverted PN23 [ITU-T O.181 test pattern], PN31, or inverted PN31).
- Default Overhead: A1 and A2 are set to (hexadecimal) F6H and 28H, respectively; the J0 byte is set to 1; 15 Z0 bytes and 32 National Use bytes (formerly C1 bytes) are numbered from 2 to 48; H1 is set to 6AH and H2 is set to 0AH in a SDH network; B1 contains B1 BIP and B2 contains B2 BIP; all other overhead bytes are equal 00H.
- Timing: Output data timing in internal mode may be derived from one of the following three sources:
 - Internal 155.52 MHz \pm 20ppm crystal oscillator
 - Externally applied 1.544 Mb/s BITS clock (input on rear-panel)
 - Externally applied 2.048 MHz or 2.048 Mb/s SETS clock (front panel input)

THRU (Through) Mode

This mode is only usable when the receiver is framed to a valid 2.488 Gb/s SDH/SONET signal.

- Data: 2.488 Gb/s output is copied from the incoming 2.488 Gb/s signal
- Default Overhead: Copied from the incoming 2.488 Gb/s signal except B1 BIP-8 and B2 BIP-24 x 16 are recomputed before re-transmission.

Overhead Manipulation Specifications

The Regenerator Section Overhead and Multiplex Section Overhead are constructed as follows:

In External Add mode, overhead bytes are copied from the multiplexed tributary. In the *All* mode copies are used to fill the entire STM-16 overhead; in the *Single* mode one copy is sent to the selected channel and the remaining channels are filled with the Unequipped channel overhead. In the Internal mode all channels are filled with the Unequipped channel overhead. In through mode the overhead is copied from the incoming STM-16. The J0 byte is set to 1; 15 Z0 bytes and 32 National Use bytes (formerly C1 bytes) are numbered from 2 to 48. The first STM-1 of the STM-16 signal overhead bytes can be edited by the user (see below), error injection can be added, and finally B1 and B2 parity bytes are calculated.

Overhead byte editing.

The following Transport Overhead (TOH) bytes of the first STM-1 of the STM-16 frame can be edited and selected individually or as a group:

J0, E1, F1, D1-D3 (group selected), C2, K1, K2, D4-D12 (group selected), S1, M1, E2

The following TOH bytes of the first STM-1 of the STM-16 frame CANNOT be edited:

A1, A2, B1, B2, H1-H3, J1

Some TOH bytes can be altered thru alarm and error generation as follows:

- 1) Generating errored frames will invert A1 and A2 bytes.
 - 2) Generating MS-RDI will force least significant 3 bits of K2 to 110.
 - 3) Generating MS-AIS will force least significant 3 bits of K2 to 111.
 - 4) B1 error injection inverts one or more bits in B1 byte.
 - 5) B2 error injection inverts one or more bits in one or more B2 bytes.
 - 6) MS-REI error injection sets M1 byte to indicate one or more errors.
- None of the Path Overhead (POH) bytes in any STM-1 can be edited.

Overhead Bytes Generated by the ST2400A

A1, A2 set to F6H, 28H.

J0 (STM-1 channel 1) is set to 1; 15 Z0 set to 2 thru 16; 32 National Use (formerly C1) set to 17 thru 48.

B1 (STM-1 channel 1 only) filled with calculated RS BIP-8 parity.

B2 (all 16 channels) filled with calculated MS BIP-24 parity.

H1, H2 (STM-1 col 1) set to 6AH, 0AH; H1, H2 (STM-1 cols 2,3) set to 9BH, FFH

All other Transport Overhead (TOH) set to 0 by default.

J1 in Path Overhead is set to 0.

C2 in Path Overhead is set to 0 (unequipped).

B3 BIP in Path Overhead is set to correctly computed parity.

All other VC4 Path Overhead (POH) is set to 0 by default.

Error Injection

Error Rates: All error rates, can be selected in the form X Y e-Z.

B1 or B2 single error or error rate is generated by inverting a random bit in the byte. The B1 rate ranges from 2.5e-5 to 0.1e-9. The B2 rate ranges from 1.0E-3 to 0.1E-9.

Selected Channel: Single error or error rate, caused by inverting a random bit in a specific STM-1 of the 2.488 Gb/s signal. Selected channel error rate ranges from 1.0E-3 to 0.1E-9.

All channels: Single error or error rate, caused by inverting a random bit in the 2.488 Gb/s signal. All channel error rate ranges from 1.0E-3 to 0.1E-9.

MS-REI: The STM-16 M1 byte is overwritten to convey the error count.

Defect/ Alarm Generation

LOS: 2.488 Gb/s output is forced to all zeros for a user selected time, from 1 to 127 microseconds with a resolution of 1 microseconds, or 0.1 to 9.9 seconds, or continuously.

LOF, OOF: All of the A1 and A2 bytes of the 2.488 Gb/s output are inverted for a user selected time. The time is selected in frames, up to 127, or 0.1-9.9 seconds, or continuous.

MS-AIS: The MS OH and the entire SPE are set to all ones for a user selected time. The time is selected in frames, up to 127, or 0.1 to 9.9 seconds, or continuous.

MS-RDI: The '110' code is set in the three least significant bits of the K2 byte for a user selected time. The time is selected in frames, up to 127, or 0.1 to 9.9 seconds, or continuous.

Source Monitoring

External SDH inputs to the generator section are monitored to ensure valid signals for multiplexing and timing generation.

LOS: Detects the Loss of Signal alarm by monitoring the user-selected external 155 or 622 Mb/s inputs for activity.

LOF: Detects the Loss of Frame alarm by monitoring an OOF condition for 3 ms on the user-selected external 155 or 622 Mb/s input.

Receiver (Analyzer) Specifications

Measurements

B1 Errors: The 2.488 Gb/s input is monitored for Regenerator Section level errors by comparing the received B1 byte to the recomputed BIP-8 parity. The errors are detected and counted. They can be displayed as a total error count or an error rate in the form $X.Y e^{-Z}$.

B2 Errors: The 2.488 Gb/s input is monitored for Multiplex Section errors by comparing the 48 received B2 bytes to the recomputed BIP-24 x 16 parity. The errors are detected and counted. They can be displayed as a total error count or an error rate in the form $X.Y e^{-Z}$.

MS-REI: The 2.488 Gb/s input is monitored for MS-REI in the M1 byte. REIs are detected and counted. They are displayed as a total error count.

Alarms Detection

LOS: 2.488 Gb/s input is monitored for the all zero condition. When the 2.4 Gb/s signal has been off for more than 2 microseconds the LOS condition is declared. The LOS alarm will assert no later than 127 microseconds after receiving the low signal (all zero) condition.

LOF, OOF: The last A1 byte and the first two A2 bytes (A1, A2, A2) of the 2.488 Gb/s input are monitored for errors. If 4 or more consecutive frames have errors OOF is declared and reframing is attempted. If OOF persists for more than 3 milliseconds LOF is declared.

AIS: The K2 byte is monitored for occurrence of all ones in three least significant bits.

- SDH: If it occurs in three consecutive frames MS-AIS is declared.

MS-RDI: The K2 byte is monitored for occurrence of the '110' code in three least significant bits.

- SDH: If it occurs in three consecutive frames MS-RDI is declared.

Overhead Display

Approximately every 100 milliseconds each byte of the first STM-1 Transport Overhead is extracted and displayed.

APS Display

Approximately every 100 milliseconds the K1 and K2 bytes are extracted. The bytes are decoded, into the APS messages, modes and channels and displayed.

SONET/SDH Drop Modes

The analyzer drops a SONET/SDH signal at either 155 Mb/s or 622 Mb/s. A valid SONET/SDH signal is constructed from a fraction of the 2.488 Gb/s input data and overhead.

155 Drop Mode

Data: User selects 1 of the 16 155 Mb/s channels in the 2.488 Gb/s input data to copy to the drop signal.

Overhead: B1, B2 in dropped STM-1 are recalculated by the ST2400A.

H1, H2, and H3 are copied from the selected drop channels.

The remainder of the drop signal overhead is copied from the first three columns of the 2.488 Gb/s input.

Output: This mode is valid on the 155 Mb/s optical and electrical (CMI) outputs.

622 Drop Mode

Data: User selects 1 of the 4 622 Mb/s channels in the 2.488 Gb/s input data to copy to the drop signal.

Overhead: B1, B2 in dropped STM-4 are recalculated by the ST2400A

H1, H2, and H3 are copied from the selected drop channels.

The first three columns of the remainder of the drop signal overhead are copied from the first three columns of the 2.488 Gb/s input. The last nine columns of the remainder are copied from the selected drop channel.

Output: This mode is valid only on the 622 Mb/s optical output.

Input and Output Specifications, Generator (TX)

Laser Module Requirements (2.488 Gb/s Lasers)

Laser modes are pigtailed with type 5D, 8 μm core, non-dispersion shifted single-mode fiber (per ITU-G.652).

2.488 Gb/s lasers in the ST2400A SDH test set are Class IIIA per IEC 825-1.

Direct Modulated (DM)

DM Laser Module Optical Specifications:

Symbol	Parameter	Min.	Max	Unit
λ	Wavelength (nom. 1310 nm) [Opt. 13, 17]	1304	1316	nm
λ	Wavelength (nom. 1550 nm) [Opt. 15, 17]	1544	1556	nm; not including the laser temperature tuning
λ	Wavelength (select 1550 nm) [Opt.]	1530	1565	nm; per ITU G.692 grid
$\Delta\lambda$	λ Adjustment Range (applies only to 1550 nm lasers)	± 1.0		nm
	λ Adjustment Resolution		0.1	nm
	Optical Wavelength Stability	± 0.1		nm; With modulation
$\Delta\lambda_{20}$	Spectral width (20 dB)		1.0	nm; With modulation
SSR_{\min}	Side mode suppression ratio	30		dB
P_o	Average Output Power	-2.0	+3.0	dBm (includes connector loss and WDM module)
ΔP_o	Optical Output Power Variation, typical		± 0.1 typical	dB; 5 min @ constant λ & modulation off
ΔP_o	Optical Output Power Variation, typical		± 0.5 typical	dB; between modulation ON and modulation OFF
P_{OH}/P_{OL}	Extinction ratio Optical waveform	10		dB; modulation On ITU-T G.957

Signal Name: 2.488 Gb/s Optical Output Data

Connector: FC/PC (standard), SC, or ST available

This output can be “locked out” for safety (as UL safety requirements specify) using the rear panel key switch or remote interlock.

Fiber Type: Single Mode

Description: Primary output to device under test

Signal Name: 155 Mb/s / 622 Mb/s Input Data

Connector: FC/PC (standard), SC, or ST available, Type: Optical

Wavelength: 1310 or 1550 nm, Maximum Input: -8 dBm

Sensitivity: -28 dBm minimum

Fiber Type: Multi-Mode

Description: 155 or 622 Mb/s data input to multiplexer, intended for connection to supplemental test equipment.

Signal Name: 155 Mb/s Electrical Input

Connector: BNC - 75 Ω

Type: CMI per Bellcore GR-253-CORE and CCITT Rec. G.708, G.709. CMI is adjusted and guaranteed to meet output pulse mask only at room temperature (25 degrees C \pm 5 degrees C).

Description: 155 Mb/s electrical data input to multiplexer, intended for connection to supplemental test equipment.

SYNC Output

SYNC Output (Clock Trigger) is an AC-coupled output. The voltage level is 300 mV minimum. This output needs a 50-Ohm termination to work properly. This output is used to trigger a oscilloscope to measure the eye diagram of an OC-48/STM-16 signal. Output rate is 1/8th Transmit data rate (approximately 311 MHz).

Frame Sync

Connector: BNC - 50 Ω Type: ECL with internal pull-down, series 50 ohm.

Description: Derived from generator, pulse width of 25.8 ns.

Event trigger

Connector: BNC - 50 Ω Type: TTL

Description: Active during LOS, LOF, AIS, FERF, Error Inject, or TOH byte edit.

2.488 Gb/s Electrical Outputs

Single-ended clock and data interfaces; unterminated ECL; requires connection to an AC-coupled 50 Ohm termination through a bias-tee network supplying current for the ECL outputs; falling edge of output clock coincides with data edge crossing ± 100 ps; SMA connectors. ECL specifications: At high output voltage, 25° C, -0.98 V (min). At low output voltage, 25° C, -1.95 V (min) and -1.63 V (max).

Input and Output Specifications, Analyzer (RX)

Signal Name: 2.488 Gb/s Optical Input Data

Connector: FC/PC (standard), ST, or SC available

Type: InGaAs APD optical receiver

Wavelength: 1310 / 1550 nm

Fiber Type: Single Mode

Description: Primary optical input from device under test

APD Receiver Module

APD Receiver Optical Specifications

Symbol	Parameter	Min	Max	Unit	Notes / Conditions
P_i	Max Optical Input Power under bias (no damage)		-10	dBm	APD enabled; Damage will occur if exceeded.
P_i	Max Optical Input Power under no bias		-10	dBm	APD Disabled; Damage will occur if exceeded.
F_{max}	Maximum data rate	-20	+20	ppm	offset from 2.48832 Gb/s
λ	Optical wavelength for rated sensitivity	1250	1600	nm	
P_{Rmin}	RX Optical Sensitivity	-28		dBm	10^{-12} BER; flat loss
P_{Rmax}	RX Optical Overload	-10		dBm	10^{-12} BER; flat loss
P_O	Optical Power Penalty		2	dB typical	Sensitivity degradation due to dispersion, reflections.
τ_{LOS}	Loss of signal delay	2	127	μ s	
τ_{ACQ}	Acquisition/recovery time		800	μ s	
	Receiver Reflectance		-27	dB	
	Residual Bit Error Rate		10^{-14}	BER	@ -15dBm \pm 3dB

2.488 Gb/s Electrical Inputs

AC-coupled 50 Ohm terminated ECL clock and data interfaces; allow ST2400A to operate error-free when electrical outputs are looped to electrical inputs through a bias-tee termination; data valid when sampled within ± 50 ps of center of data eye; SMA connectors. ECL specifications: At high input voltage, 25° C, -0.98 V (min). At low input voltage, 25° C, -1.95 V (min) and -1.63 V (max).

Signal Name: 155 Mb/s / 622 Mb/s Output Data

Connector: FC/PC (standard), ST, or SC available

Type: Optical

Wavelength: 1310 nm (1273 to 1355 nm)

Average Power: -15 dBm minimum

Maximum Average Power: -8 dBm

Category: IR-1

Fiber Type: Single Mode

Description: 155 or 622 Mb/s data output from demultiplexer, intended for connection to supplemental test equipment.

Safety Classification: Class I per IEC 825-1.

Signal Name: 155 Mb/s Electrical Output

Connector: BNC - 75 Ω

Type: CMI per Bellcore GR-253-CORE and CCITT Rec. G.708, G.709. CMI is adjusted and guaranteed to meet output pulse mask only at room temperature (25 degrees C \pm 5 degrees C).

Description: 155 Mb/s electrical data output from demultiplexer, intended for connection to supplemental test equipment.

GPIO I/O

Connector, signal level, and protocol per IEEE 488.2

Description: Byte serial industry standard instrument interface, used for remote or automated control of the ST2400A.

Serial I/O

RS232C Connector, signal level and protocol per ANSI RS-232C

Description: Bit serial industry standard interface, used for remote control and software download of the ST2400A. External null modem not required.

ST112-RS232C Connector, signal level and protocol per ANSI RS-232C

Description: Bit serial interface, used for directly connecting to an ST112 for combined mode operation. External null modem is not required.

Printer Output

Connector: DB-25, Signal: TTL

Description: Byte serial ASCII printer interface. Follows industry standard DB-25 translation of Centronics interface

Synchronization Specifications

Generator Timing

The 2.488 Gb/s output can derive synchronization from five different sources. These sources are only valid in the indicated modes.

External Timing

The output timing is obtained by phase lock loop (PLL) multiplying the clock recovered from the source 155/622 Mb/s SONET/SDH signal. This timing mode is valid only when the generator is in EXT (external) mode. To obtain loop timing in these modes the supplemental test equipment providing Path and payload testing must be set to loop timing. This is the only generator timing mode valid with external lower rate test equipment.

Source Frequency Range: 155.52 Mb/s \pm 100 ppm or 622.08 Mb/s \pm 100 ppm

Loop Timing (THRU Mode)

The output timing is obtained from the 2.488 Gb/s SONET/SDH signal input to the analyzer. The clock recovered from this input generates the output signal.

Source Frequency Range: 2.48832 Gb/s \pm 20 ppm.

Internal Timing

The output timing is obtained from an internal clock source. This timing mode can be used if the generator is in internal mode operating stand-alone.

Output Frequency Accuracy: 2.48832 Gb/s \pm 20 ppm.

Output Jitter: Meets Bellcore GR-253-CORE and ITU G.783, G.813

1.544 Mbps External Reference (BITS Clock) Timing

Only valid in Internal Mode.

ST-2400A accepts 1.544 Mb/s \pm 40ppm BITS input for internal signal generation using external timing synchronization. BITS input shall accept signals meeting the requirements of ANSI T1.101-1994 with the exception of frequency tolerance of +/- 40ppm. The BITS Input Bantam connector on the rear panel provides this input.

2 MHz / 2 Mbps External Reference (SETS Clock) Timing

Only valid in Internal Mode.

ST-2400A accepts 2.048 Mb/s / 2.048 MHz \pm 40ppm SETS input for internal signal generation using external timing synchronization. SETS input shall accept signals meeting the requirements of G.703 section 10 (2.048 Mb/s) and section 6 (2.048 MHz), with the exception of frequency tolerance of +/- 40ppm. The 155/2.048 BNC connector on the front panel provides this input.

Analyzer Timing

Analyzer Clock Recovery

Input Frequency Range: 2.48832 Gb/s \pm 20 ppm.

Input Jitter Tolerance: Meets Bellcore GR-253-CORE and ITU G.783, G.81S

155/622 Mb/s Output Timing

Derived by dividing the clock recovered from the Analyzer 2.488 Gb/s input.

Jitter Transfer

ST2400A Jitter Transfer is a function of the clock recovery, clock multiply, and/or clock divide function in the Transmitter or Receiver. The Transmitter recovers clock from the 155 MHz or 622 MHz inputs, then multiplies them up to 2.488 GHz. In THRU Mode, the Transmitter gets a 78 MHz clock from the Receiver and multiplies that to 2.488 GHz. The Receiver divides its input 2.488 GHz clock to 155 MHz or 622 MHz for the tributary drop rates, or to 78 MHz for the Transmitter in THRU Mode. The resulting maximum peak-peak Jitter Gain is shown in the tables and diagram below.

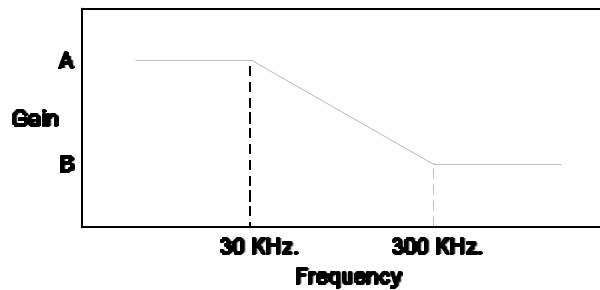

SONET Jitter Transfer	A	B
OC-3 input to OC-48 Tx output	25db	10db
CMI input to OC-48 Tx output	25db	10db
OC-12 input to OC-48 Tx output	15db	-5db
OC-48 Rx input to OC-48 Tx output	.3db	.3db
OC-48 Rx input to OC-3 output	-24db	-24db
OC-48 Rx input to CMI output	-24db	-24db
OC-48 Rx input to OC-12 output	-12db	-12db

SDH Jitter Transfer	A	B
STM-1 input to STM-16 Tx output	25db	10db
CMI input to STM-16 Tx output	25db	10db
STM-4 input to STM-16 Tx output	15db	-5db
STM-16 Rx input to STM-16 Tx output	.3db	.3db
STM-16 Rx input to STM-1 output	-24db	-24db
STM-16 Rx input to CMI output	-24db	-24db
STM-16 Rx input to STM-4 output	-12db	-12db

Incoming Inspection Test

The purpose of this procedure is to verify that the ST2400A Transceiver received from Tektronix is operational upon arrival. This procedure briefly verifies that the general functionality of the unit responds correctly.

The incoming inspection is divided into separate tests for SDH and SONET.

The last page of this section details a method for cleaning optical cables.

Required Equipment

The following equipment is required to verify that the ST2400A Transceiver is functioning properly.

- Fiber Optical Cable - must be a single mode cable and have connectors matching those on the unit under test
- In-line 15db optical attenuator
- Optical cleaning kit (*Note: See last page of instructions for required equipment*)

NOTE: This procedure may also be used to verify correct operation of an ST2400A Transmitter Only, but a known good ST2400A Receiver is required. Similarly, an ST2400A Receiver may be tested with a known good ST2400A Transmitter.

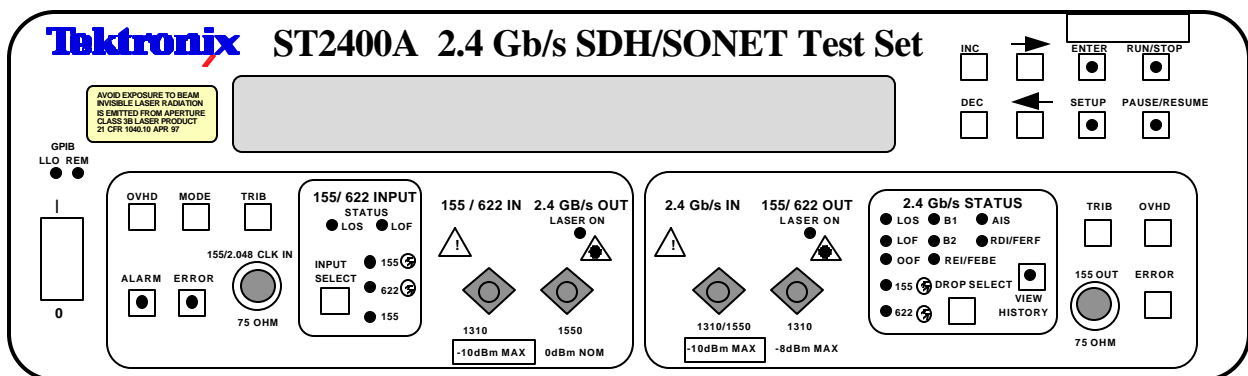

Figure B-1. ST2400A front panel - Transmitter (left-side) and Receiver (right-side)

General Functionality Verification

This section of the User Manual tests the functionality of the unit. The procedure consists of eleven sections in which the functionality of the unit is verified. *Note: The procedure assumes you are proceeding in sequential order.* Before beginning the procedure, you must set the unit to factory default settings to ensure that you are starting the procedure from a known state. To default the unit to its factory settings, follow the procedure below.

1. On the front panel, press SETUP until the display shows the STORE/RECALL Setup menu.
2. Using the LEFT/RIGHT cursors, select FACTORY DEFAULT and then press ENTER. *Note: Whenever you make a change in a menu, the red LED within the ENTER key will flash. This signifies that if you wish that change to occur, you must save it by pressing ENTER.*
3. The display now reads “Restore Factory Default?”. Using the LEFT/RIGHT cursors, select YES and press ENTER. The display flashes a message stating that all settings have been returned to factory defaults, then it returns to the REPORT/TEST Setup menu.
4. Once the factory default settings have been restored, observe that all the error lights within the 2.4 Gb/s STATUS section of the receiver front panel are lit. This is because the default settings set the laser to OFF, so the unit is no longer linked.

Now that the unit has been correctly defaulted, you may continue with the next section of the procedure.

STM-16 (SDH) Quick Setup

This section of the procedure verifies that the SDH mode for STM-16 is functioning properly. The quick setup places the unit into a default mode which selects specific settings for the unit. These default settings are preprogrammed and therefore consistent from unit to unit. Leave everything as it was in the last section of the procedure. There are nine steps in this section of the procedure. Before any connections are made, use the optical cleaning kit to clean the cable ends, the attenuator ends, and the optical connectors on the front panel of the unit. *Note: The last section of the procedure provides an equipment list and simple instructions on how to clean the optical connectors.*

1. On the front panel, remove protective covers from the 2.4Gb/s IN and OUT connectors.
2. Connect a fiber-optic cable with an in-line 15db attenuator between transmitter side (left side) 2.4Gb/s OUT to receiver side (right side) 2.4Gb/s IN.
3. On the front panel, press SETUP until the display shows the Auxiliary Setup menu and press ENTER.
4. On the front panel, press SETUP until the display shows the System Configuration menu.
5. Using the LEFT/RIGHT cursors, select SDH and then press ENTER. The display then flashes a message stating that the program is restarting (due to measurement mode change). Wait until unit reboots.

6. On the front panel, press SETUP until the display shows the LASER 1 (1310nm or 1550nm) menu.
NOTE: For dual wavelength ST-2400As, the following tests should be repeated for LASER 2.
7. Using the LEFT/RIGHT cursors, select ON and then press ENTER. *Note: On the transmitter side of the front panel, the red LED under LASER ON is now lit. Refer to Figure B-1 to identity the transmitter and receiver side of the front panel.*
8. The transmitter and receiver sides should now be linked error-free. *Note: Error-free means that you see no lit LEDs in the 2.4Gb/s STATUS section on the receiver side of the front panel.*

Parity and Random Errors (SDH)

At this point, you have determined that the unit links error-free. The next step is to inject some errors and verify that the unit responds correctly. This section is split into two parts: Single Error Inject Test and Error Rate Inject Test. Leave the setup as it was in the last section.

Single Error Inject Test

In this part, the transmitter is set to generate STM-16 from 16 STM-1 signals containing PRBS $2^{23}-1$ test pattern, then injects single errors into the receiver and verifies the responses of the receiver. There are 27 steps in this section of the procedure.

1. On the transmitter side of the front panel, press MODE until the display shows the INT TX VC4 TEST PATT menu.
2. Using the LEFT/RIGHT cursors, select PRBS 23, then press ENTER.
3. On the receiver side of the front panel, press MODE until the display shows the INT RX VC4 TEST PATT menu.
4. Using the LEFT/RIGHT cursors, select PRBS 23, then press ENTER.
5. On the transmitter side of the front panel, press ERROR until the display shows the Single Error Inject menu.
6. On the front panel, press RUN/STOP until the green LED inside the button is now lit.
Note: The unit is now in RUN mode. If the green LED within the switch is not lit, then the RUN mode is not active and no errors will be counted (i.e. a STOP condition exists).
7. Using the LEFT/RIGHT cursors, select B1 and then press ENTER twice.
8. In the 2.4Gb/s STATUS section, observe that error light for B1 flashes twice.
9. On the receiver side of the front panel, press ERROR until the display shows B1 on the bottom left corner. Observe that B1 errored seconds (ES) = 1 or 2 and total errors (TOT) = 2.
10. On the transmitter side of the front panel, press ERROR until the display shows the Single Error Inject menu.
11. On the transmitter side of the front panel, press ERROR until the display shows the Single Error Inject menu.
12. Using the LEFT/RIGHT cursors, select B2 and then press ENTER twice.

13. In the 2.4Gb/s STATUS section, observe that the error light for B2 flashes twice.
14. On the receiver side of the front panel, press ERROR until the display shows B2 on the bottom left corner. Observe that B2 errored seconds (ES) = 1, 2, 3, or 4 and total errors (TOT) = 4.
15. On the transmitter side of the front panel, press ERROR until the display shows the Single Error Inject menu.
16. Using the LEFT/RIGHT cursors, select MS-REI and then press ENTER twice.
17. In the 2.4Gb/s STATUS section, observe that the error light for REI/FEBE flashes twice.
18. On the receiver side of the front panel, press ERROR until the display shows REI on the bottom left corner. Observe that REI errored seconds (ES) = 1 or 2 and total errors (TOT) = 2.
19. On the front panel, press RUN/STOP twice. Observe that the errors have now been reset to zero.

Note: Whenever errors are being cleared, verify that you are still in RUN mode after the errors are cleared.

Error Rate Inject Test

In this part, the transmitter injects an error rate into the receiver and verifies the receiver's responses. There are 20 steps in this section of the procedure.

1. On the transmitter side of the front panel, press ERROR until the display shows the Random BER Inject menu.
2. Using the LEFT/RIGHT cursors, select 1.0E-3 and then press ENTER. Observe that the red LED within the ERROR switch is now lit.
3. In the 2.4Gb/s STATUS section, observe that the error lights for B1, B2, and REI/FEBE remain lit. You have now injected an error rate into the receiver.
4. On the receiver side of the front panel, press ERROR until the display shows RS-B1 and MS-B2 on the top line. Observe that they both have increasing error counts. B1 and B2 overflow is indicated by an * in the most significant digit.
5. On the front panel, press PAUSE/RESUME until the red LED within the switch is lit.
6. On the display, observe that the error rates are no longer increasing, but are fixed at one value. Also, in the 2.4Gb/s STATUS section, observe that the error lights for B1, B2, and REI/FEBE remain lit.

Note: When the red LED within the PAUSE/RESUME switch is lit, the unit is in PAUSE mode and will freeze all error conditions. When the red LED is within the PAUSE/RESUME switch is turned off, the unit will RESUME normal functioning.

7. On the display, press PAUSE/RESUME until the red LED within the switch is no longer lit.
8. On the display, observe that the error rates are once again increasing. Also, in the 2.4Gb/s STATUS section, observe that the error lights for B1, B2, and REI/FEBE still remain lit.
9. On the front panel, press RUN/STOP twice to restart a test.
10. On the receiver side of the front panel, press ERROR until the display shows B2 on the bottom left corner. Observe that BER = 1.0E-3.

NOTE: B1 BER will not measure 1.0E-3 since this exceeds the maximum error rate measurable with B1 error detection. Also, MS-REI will not measure 1.0E-3 since random error injection will only cause REI errors when the M1 byte containing the REI count is errored.

11. On the transmitter side of the front panel, press ERROR until the display shows the Random BER Inject menu.
12. Using the LEFT/RIGHT cursors, select OFF and then press ENTER. Observe that the red LED within the ERROR switch is now off.
13. In the 2.4Gb/s STATUS section, observe that the error lights for B1, B2, and REI/FEBE are now off.
14. On the receiver side of the front panel, press ERROR until the display shows RS-B1 and MS-B2 on the top line. Observe that the errors have stopped increasing.
15. On the front panel, press RUN/STOP twice to clear all errors.

Transport Overhead/Path Overhead (SDH)

This section of the procedure ensures that the editing function is working accurately. Leave the setup as it was in the last section.

1. On the transmitter side of the front panel, press OVHD until the display shows J0 on the top right side.
2. Using the LEFT/RIGHT cursors, select SET.
3. Using the INC/DEC keys, change J0 to 51 and then press ENTER.
4. On the receiver side of the front panel, press OVHD until the display shows A1, A2, and J0 on the top right side.
5. On the display, observe that J0 equals 51. Verify A1 equals F6; A2 equals 28.
6. On the transmitter side of the front panel, press OVHD until the display shows J0 on the top right side.
7. Using the LEFT/RIGHT cursors, select PASS and then press ENTER.
8. On the receiver side of the front panel, press OVHD until the display shows A1, A2, and J0 on the top right side.
9. On the display, observe that J0 equals 01.
10. On the transmitter side of the front panel, press OVHD until the display shows D7, D8, and D9 on the top right side.
11. Using the LEFT/RIGHT cursors, select SET and select D7.
12. Using the INC/DEC keys and the LEFT/RIGHT cursors, change D7 to AA.
13. Using the LEFT/RIGHT cursors, select D8.
14. Using the INC/DEC keys and the LEFT/RIGHT cursors, change D8 to 11.
15. Using the LEFT/RIGHT cursors, select D9.
16. Using the INC/DEC keys and the LEFT/RIGHT cursors, change D9 to 05 and then press ENTER.
17. On the receiver side of the front panel, press OVHD until the display shows D7, D8, and D9 on the top right side.
18. On the display, observe that D7, D8, and D9 all reflect the values you placed into the transmitter (i.e. D7 = AA, D8 = 11, and D9 = 05).
19. On the transmitter side of the front panel, press OVHD until the display shows D7, D8, and D9 on the top right side.
20. Using the LEFT/RIGHT cursors, select SET and select D7.
21. Using the INC/DEC keys and the LEFT/RIGHT cursors, change D7 to 00.
22. Using the LEFT/RIGHT cursors, select D8.
23. Using the INC/DEC keys and the LEFT/RIGHT cursors, change D8 to 00.
24. Using the LEFT/RIGHT cursors, select D9.

25. Using the INC/DEC keys and the LEFT/RIGHT cursors, change D9 to 00 and then press ENTER.
26. On the receiver side of the front panel, press OVHD until the display shows D7, D8, and D9 on the top right side.
27. On the display, observe that the values of D7, D8, and D9 are once again zero.

Continuous Alarms (SDH)

This section of the procedure ensures that the continuous alarm settings are functioning properly. There are five parts, each part checking a different alarm. Leave the setup as it was in the last section.

Loss of Signal Alarm

In this part, the transmitter creates a loss of signal alarm and you verify the responses of the receiver. There are eight steps in this section of the procedure.

1. On the transmitter side of the front panel, press ALARM until the display shows the Loss of Signal menu.
2. Using the LEFT/RIGHT cursors, select 2.5SEC.
3. Using the INC key, increase the time until it switches to CONT and then press ENTER.
4. On the display, observe that the top right corner now says “*ACTIVE”.

Note: The red LED within the ALARM switch is now lit. Whenever an alarm is active, this LED will turn on.

5. In the 2.4Gb/s STATUS section, observe that the LOS, LOF, OOF, B1, B2, and REI/FEBE LEDs are now lit.
6. Using the LEFT/RIGHT cursors, select OFF and then press ENTER.
7. In the 2.4Gb/s STATUS section, observe that all of the error lights are now off.
8. On the front panel, press RUN/STOP twice to clear all errors.

Errored Frame Alarm

In this part, the transmitter creates an errored frame alarm and you verify the responses of the receiver. There are eight steps in this section of the procedure.

1. On the transmitter side of the front panel, press ALARM until the display shows the Errored Frame menu.
2. Using the LEFT/RIGHT cursors, select 2.5SEC.
3. Using the INC key, increase the time until it switches to CONT and then press ENTER.
4. On the display, observe that the top right corner now says “*ACTIVE”.
5. In the 2.4Gb/s STATUS section, observe that the error lights for LOF, OOF, B1, B2, REI/FEBE, AIS, and RDI/FERF are now lit.
6. Using the LEFT/RIGHT cursors, select OFF and then press ENTER.
7. In the 2.4Gb/s STATUS section, observe that all of the error lights are now off.
8. On the front panel, press RUN/STOP twice to clear all errors.

RDI Alarm

In this part, the transmitter creates an RDI alarm and you verify the responses of the receiver. There are eight steps in this section of the procedure.

1. On the transmitter side of the front panel, press ALARM until the display shows the MS-RDI menu.
2. Using the LEFT/RIGHT cursors, select 2.5SEC.
3. Using the INC key, increase the time until it switches to CONT and then press ENTER.
4. On the display, observe that the top right corner now says “*ACTIVE”.
5. In the 2.4Gb/s STATUS section, observe that the error light for RDI/FERF is now lit.
6. Using the LEFT/RIGHT cursors, select OFF and then press ENTER.
7. In the 2.4Gb/s STATUS section, observe that the error light for RDI/FERF is now off.
8. On the front panel, press RUN/STOP twice to clear all errors.

AIS Alarm

In this part, the transmitter creates an AIS alarm and you verify the responses of the receiver. There are eleven steps in this section of the procedure.

1. On the transmitter side of the front panel, press ALARM until the display shows the MS-AIS menu.
2. Using the LEFT/RIGHT cursors, select 2.5SEC.
3. Using the INC key, increase the time until it switches to CONT and then press ENTER.
4. On the display, observe that the top right corner now says “*ACTIVE”.
5. In the 2.4Gb/s STATUS section, observe that the error lights for REI/FEBE and AIS are now lit. B2 will flash and go out.
6. On the receiver side of the front panel, press ERROR until the display shows RS-B1 and MS-B2 on the top line.
7. On the display, observe that MS-B2 has an error reading that is actively counting errors.
8. On the transmitter side of the front panel, press ALARM until the display shows the MS-AIS menu.
9. Using the LEFT/RIGHT cursors, select OFF and then press ENTER.
10. In the 2.4Gb/s STATUS section, observe that the error lights for REI/FEBE and AIS are now off.
11. On the front panel, press RUN/STOP twice to clear all errors.

Inject LOS Alarm

In this part, the transmitter injects a loss of signal alarm and you verify the responses of the receiver. There are eight steps in this section of the procedure.

1. On the transmitter side of the front panel, press **ALARM** until the display shows the Inject LOS menu.
2. Using the **LEFT/RIGHT** cursors, select **ENABLE** and then press **ENTER**.
3. In the 2.4Gb/s **STATUS** section, observe that the **LOS**, **LOF**, **OOF**, **B1**, **B2**, and **REI/FEBE** LEDs flash on and off continuously every 2.5 seconds.
4. Using the **LEFT/RIGHT** cursors, select **OFF** and then press **ENTER**.
5. In the 2.4Gb/s **STATUS** section, observe that all of the error lights now remain off.
6. On the front panel, press **RUN/STOP** twice to clear all errors.

OC48 (SONET) Quick Setup

This section of the procedure verifies that the SONET mode for OC48 is functioning properly. The quick setup places the unit into a default mode, which selects specific settings for the unit. These default settings are preprogrammed and therefore consistent from unit to unit. Leave the setup as it was in the last section.

1. On the front panel, press **SETUP** until the display shows the Auxiliary Setup menu. Press **ENTER**.
2. On the front panel, press **SETUP** until the display shows the System Configuration menu.
3. Using the **LEFT/RIGHT** cursors, select **SONET** and then press **ENTER**. The display then shows a message stating that the program is restarting (due to mode change). Wait until unit reboots.
4. On the front panel, press **SETUP** until the display shows the **LASER 1** menu. *NOTE: For dual wavelength ST2400As, the following tests should also be repeated for **LASER 2**.*
5. Using the **LEFT/RIGHT** cursors, select **ON** and then press **ENTER**.
6. The transmitter and the receiver sides should now be linked error-free.

Parity and Random Errors (SONET)

At this point, you have determined that the unit links error-free. The next step is to inject some errors and verify that the unit responds correctly. This section is split into two parts: Single Error Inject Test and Error Rate Inject Test. Leave the setup as it was in the last section.

Single Error Inject Test

In this part, the transmitter is set to generate OC-48 from sixteen STS-3c signals containing the PN23 test pattern, then injects single errors into the receiver and verifies the responses of the receiver.

1. On the transmitter side, press **MODE** until the display shows the **INT TX STS-1 TEST PATT** menu.
2. Using the **LEFT/RIGHT** cursors, select **PN23**, then press **ENTER**.
3. On the transmitter side, press **ERROR** until the display shows the **Single Error Inject** menu.
4. On the front panel, verify that the **RUN** mode is active.
5. Using the **LEFT/RIGHT** cursors, select **B1** and then press **ENTER** twice.
6. In the **2.4Gb/s STATUS** section, observe that error light for **B1** flashes twice.
7. On the receiver side, press **ERROR** until the display shows **B1** on the bottom left corner. Observe that **B1** errored seconds (**ES**) = 1 or 2 and total errors (**TOT**) = 2.
8. On the transmitter side, press **ERROR** until the display shows the **Single Error Inject** menu.
9. Using the **LEFT/RIGHT** cursors, select **B2** and then press **ENTER** twice.
10. In the **2.4Gb/s STATUS** section, observe that the error light for **B2** flashes twice.
11. On the receiver side, press **ERROR** until the display shows **B2** on the bottom left corner. Observe that **B2** errored seconds (**ES**) = 1 or 2 and total errors (**TOT**) = 2.

12. On the front panel, press RUN/STOP twice. Observe that the errors have now been reset to zero.

Error Rate Inject Test

In this part, the transmitter injects an error rate into the receiver and verifies the responses of the receiver.

1. On the transmitter side of the front panel, press ERROR until the display shows the Random BER Inject menu.
2. Using the LEFT/RIGHT cursors, select 1.0E-3 and then press ENTER. Observe that the red LED within the ERROR switch is now lit.
3. In the 2.4Gb/s STATUS section, observe that the error lights for B1, B2, and REI/FEBE remain lit. You have now injected an error rate into the receiver.
4. On the receiver side of the front panel, press ERROR until the display shows B1 and B2 on the top line. Observe that all of them have increasing error rates.
5. On the front panel, press PAUSE/RESUME until the red LED within the switch is lit.
6. On the display, observe that the error rates are no longer increasing, but are fixed at one value. Also, in the 2.4Gb/s STATUS section, observe that the error lights for B1, B2, and REI/FEBE remain lit.
7. On the display, press PAUSE/RESUME until the red LED within the switch is no longer lit.
8. On the display, observe that the error rates are once again increasing. Also, in the 2.4Gb/s STATUS section, observe that the error lights for B1, B2, and REI/FEBE still remain lit.
9. On the front panel, press RUN/STOP twice to restart a test.
10. On the receiver side of the front panel, press ERROR until the display shows B2 on the bottom left corner. Observe that BER = 1.0E-3.

NOTE: B1 BER will not measure 1.0E-3 since this exceeds the maximum error rate measurable with B1 error detection. Also, MS-REI (FEBE-L) will not measure 1.0E-3 since random error injection will only cause REI errors when the M1 byte containing the REI count is errored.

11. On the transmitter side of the front panel, press ERROR until the display shows the Random BER Inject menu.
12. Using the LEFT/RIGHT cursors, select OFF and then press ENTER. Observe that the red LED within the ERROR switch is now off.
13. In the 2.4Gb/s STATUS section, observe that the error lights for B1, B2, and REI/FEBE are now off.
14. On the receiver side of the front panel, press ERROR until the display shows B1, B2, and FEBE-L across the top line. Observe that all of the errors have stopped increasing.
15. On the front panel, press RUN/STOP twice to clear all errors.

Transport Overhead/Path Overhead (SONET)

This section of the procedure ensures that the editing function is working accurately. Leave the setup as it was in the last section. There are twenty-two steps in this section of the procedure.

1. On the transmitter side of the front panel, press OVHD until the display shows J0 on the top right side.
2. Using the LEFT/RIGHT cursors, select SET.
3. Using the INC/DEC keys, change J0 to 51 and then press ENTER.
4. On the receiver side of the front panel, press OVHD until the display shows A1, A2, and J0 on the top right side.
5. On the display, observe that J0 equals 51.
6. On the transmitter side of the front panel, press OVHD until the display shows J0 on the top right side.
7. Using the LEFT/RIGHT cursors, select PASS and then press ENTER.
8. On the receiver side of the front panel, press OVHD until the display shows A1, A2, and J0 on the top right side.
9. On the display, observe that J0 equals 01.
10. On the transmitter side of the front panel, press OVHD until the display shows D7, D8, and D9 on the top right side.
11. Using the LEFT/RIGHT cursors, select SET and select D7.
12. Using the INC/DEC keys and the LEFT/RIGHT cursors, change D7 to AA.
13. Using the LEFT/RIGHT cursors, select D8.
14. Using the INC/DEC keys and the LEFT/RIGHT cursors, change D8 to 11.
15. Using the LEFT/RIGHT cursors, select D9.
16. Using the INC/DEC keys and the LEFT/RIGHT cursors, change D9 to 05 and then press ENTER.
17. On the receiver side of the front panel, press OVHD until the display shows D7, D8, and D9 on the top right side.
18. On the display, observe that D7, D8, and D9 all reflect the values you placed into the transmitter (i.e. D7 = AA, D8 = 11, and D9 = 05).
19. On the transmitter side of the front panel, press OVHD until the display shows D7, D8, and D9 on the top right side.
20. Using the LEFT/RIGHT cursors, select PASS and then press ENTER.
21. On the receiver side of the front panel, press OVHD until the display shows D7, D8, and D9 on the top right side.
22. On the display, observe that the values of D7, D8, and D9 are once again zero.

Continuous Alarms (SONET)

This section of the procedure ensures that the continuous alarm settings are functioning properly. This section is split into five parts. Each part checks a different alarm. Leave the setup as it was in the last section.

Loss of Signal Alarm

In this part, the transmitter creates a loss of signal alarm and you verify the responses of the receiver. There are eight steps in this section of the procedure.

1. On the transmitter side of the front panel, press ALARM until the display shows the Loss of Signal menu.
2. Using the LEFT/RIGHT cursors, select 2.5SEC.
3. Using the INC key, increase the time until it switches to CONT and then press ENTER.
4. On the display, observe that the top right corner now says “*ACTIVE”.
5. In the 2.4Gb/s STATUS section, observe that the LOS, LOF, OOF, B1, B2, and REI/FEBE LEDs are now lit.

Note: The error lights for AIS and RDI/FERF may flash.

6. Using the LEFT/RIGHT cursors, select OFF and then press ENTER.
7. In the 2.4Gb/s STATUS section, observe that all of the error lights are now off.
8. On the front panel, press RUN/STOP twice to clear all errors.

Errored Frame Alarm

In this part, the transmitter creates an errored frame alarm and you verify the responses of the receiver. There are eight steps in this section of the procedure.

1. On the transmitter side of the front panel, press ALARM until the display shows the Errored Frame menu.
2. Using the LEFT/RIGHT cursors, select 2.5SEC.
3. Using the INC key, increase the time until it switches to CONT and then press ENTER.
4. On the display, observe that the top right corner now says “*ACTIVE”.
5. In the 2.4Gb/s STATUS section, observe that the error lights for LOF, OOF, B1, B2, REI/FEBE, AIS, and RDI/FERF are now lit.

Note: The error light for RDI/FERF may flash.

6. Using the LEFT/RIGHT cursors, select OFF and then press ENTER.
7. In the 2.4Gb/s STATUS section, observe that all of the error lights are now off.
8. On the front panel, press RUN/STOP twice to clear all errors.

FERF Alarm

In this part, the transmitter creates a FERF alarm and you verify the responses of the receiver. There are eight steps in this section of the procedure.

1. On the transmitter side of the front panel, press **ALARM** until the display shows the FERF-L menu.
2. Using the **LEFT/RIGHT** cursors, select 2.5SEC.
3. Using the **INC** key, increase the time until it switches to **CONT** and then press **ENTER**.
4. On the display, observe that the top right corner now says “*ACTIVE”.
5. In the 2.4Gb/s **STATUS** section, observe that the error light for RDI/FERF is now lit.
6. Using the **LEFT/RIGHT** cursors, select **OFF** and then press **ENTER**.
7. In the 2.4Gb/s **STATUS** section, observe that the error light for RDI/FERF is now off.
8. On the front panel, press **RUN/STOP** twice to clear all errors.

AIS Alarm

In this part, the transmitter creates an AIS alarm and you verify the responses of the receiver. There are eleven steps in this section of the procedure.

1. On the transmitter side of the front panel, press **ALARM** until the display shows the LINE-AIS menu.
2. Using the **LEFT/RIGHT** cursors, select 2.5SEC.
3. Using the **INC** key, increase the time until it switches to **CONT** and then press **ENTER**.
4. On the display, observe that the top right corner now says “*ACTIVE”.
5. In the 2.4Gb/s **STATUS** section, observe that the error lights for REI/FEBE and AIS are now lit.
6. On the receiver side of the front panel, press **ERROR** until the display shows RS FEBE-L on the top line.
7. On the display, observe that FEBE-L is actively counting errors.
8. On the transmitter side of the front panel, press **ALARM** until the display shows the LINE-AIS menu.
9. Using the **LEFT/RIGHT** cursors, select **OFF** and then press **ENTER**.
10. In the 2.4Gb/s **STATUS** section, observe that the error lights for REI/FEBE and AIS are now off.
11. On the front panel, press **RUN/STOP** twice to clear all errors.

Inject LOS Alarm

In this part, the transmitter injects a loss of signal alarm and you verify the responses of the receiver. There are eight steps in this section of the procedure.

1. On the transmitter side of the front panel, press ALARM until the display shows the Inject LOS menu.
2. Using the LEFT/RIGHT cursors, select ENABLE and then press ENTER.
3. In the 2.4Gb/s STATUS section, observe that the LOS, LOF, OOF, B1, B2, and REI/FEBE LEDs flash on and off continuously every 2.5 seconds.
4. Using the LEFT/RIGHT cursors, select OFF and then press ENTER.
5. In the 2.4Gb/s STATUS section, observe that all of the error lights now remain off.
6. On the front panel, press RUN/STOP twice to clear all errors.

You have now successfully verified that the unit is functional. If you had any problems with the unit while performing the tests, repeat the procedure paying careful attention to the setup of the units and the directions given. If the unit still has a problem, please call Tektronix Customer Sales and Support Center (CSSC) at 1-800-835-9433 x2400 or 503-627-2400 for assistance.

Factory Defaults

System setup parameters

These are restored on Powerup

Receiver Parameters

```
rx_err_disp_type = 0
rx_err_thresh_count = 5
rx_err_thresh_enable= 0
rx_err_thresh_type= 0 (MIN)
rx_err_thresh_value= 3
rx_drop_rate= RX_DROP_RATE_OFF
rx_drop_chan= 1
rx_laser_on= OFF
rx_sts_chan= 0

rx_eot_print= OFF
rx_eot_print_form= 0
rx_errlog_print= 0
rx_errlog_squelch= NONE

rx_measure_cntrl= OFF
rx_measure_run= OFF
rx_measure_secs= 10
rx_measure_timing= RX_MEASURE_UNTIMED
rx_print_recent_test= NO
rx_report_disp_type= 0
rx_report_mem_type= RX_REPORT_MEM_LOG
rx_report_mode= OFF

pause_phase= OFF
```

Transmitter Parameters

tx_optic_pow_mode= OFF
tx_error_rates [MAX_TYPES_OF_RATES]= 1.0E-5 (RANDOM BER is 1.0E-3)

These four variables are for alarm/error restore on powerup

error_rate_enabled
cycle_error_active= NO
alarm_type_enabled= NONE
cycle_alarm_active= NO

tx_alarm_burst = 1
tx_alarm_time = 25
tx_alarm_mode = OFF
cycle_alarm_inject_time= 25
cycle_alarm_dwell_time= 25
cycle_alarm_type= LOS
cycle_error_inject_time= 0
cycle_error_dwell_time= 0
cycle_error_type= OFF
tx_channel= 1
tx_chan_replicate_mode= 0
tx_input_mode= INTERNAL
tx_wavelength= 1310 or 1550 (depending on DUAL Wavelength or NOT)
tx_input_rate= OFF
tx_optic_on= OFF
tx_event_trigger= EVENT_TRIGGER_ALARM

tx_single_err_mode= OFF 2.4Gb/s single error type
tx_single_err_chan= 1 single error on a specified sts-1

oh_bytes [10][4]= 0 All are 0, except for the ones below
oh_bytes [0][2] = 0x01; J0 (was C1)
oh_bytes [1][1] = 0x7f; E1
oh_bytes [8][2] = 0x7f; E2

tx_allchan_err_mode= OFF B2 all channel error inject
tx_payload_mapping= (STS1 SONET) or (VC4 SDH) Payload Pattern choice
tx_payload_select= (All-Zeros) Payload Pattern choice
tx_ext_sync_input= OFF External sync input

toh_group_overlay_word= 0 TOH_BYTE_GROUPS

IO Board Parameters

tx_elec_output= OFF
rx_elec_input= (OPTICAL if APD is present) otherwise ELECTRICAL

Laser power = OFF
Laser wavelength offset = 0
TX elec output = OFF

System Parameters

menu_key= 0
quick_set= INT 155
setup_store_mode= OFF
setup_store_select= 0

System Parameters - NOT reset by *rst

gpiib_term= 0

rs232_baud= 9600
rs232_baud_code= 0
rs232_parity= EVEN
rs232_char_size= 0
rs232_char_size_sel= 1
rs232_eol= CR-LF
rs232_xon= OFF
rs232_echo= OFF
rs232_prompt [16]= "ST2400>"
rs232_prompt_lf= 0
remote_header= OFF

measure_mode = SONET or if "SDH DEFAULT" is set SDH

clock_century= "1998/01/01 00:00:00"
audio_vol= 1
view_angle= 4

SONET for Reference

Transmission standards in the U.S., Canada, Korea, Taiwan, and Hong Kong (ANSI) and the rest of the world (ITU-T) evolved from different basic-rate signals in the non-synchronous hierarchy. ANSI Time Division Multiplexing (TDM) combines twenty four 64 kbit/s channels (DS0) into one 1.544-Mbit/s DS-1 signal. ITU TDM multiplexes thirty 64 kbit/s channels (E0) into one 2.048 Mbit/s E1 signal (an extra two channels provide frame alignment and signaling, making thirty-two (32) total).

An important issue for the ITU-T to resolve was how to efficiently accommodate both the 1.5 Mbit/s and the 2 Mbit/s non-synchronous hierarchies in a single network standard. The agreement reached specified a basic transmission rate of 51 Mbit/s for SONET and a basic rate of 155 Mbit/s for SDH.

Synchronous and Non-synchronous line rates and the relationships between each are shown in the two tables that follow.

Table F-1. SONET/SDH Hierarchies

SONET	Bit Rate	SDH	SONET Capacity	SDH Capacity
STS-1, OC-1	51.84 Mbit/s	STM-0	28 DS1 or 1 DS3	21 E1
STS-3, OC-3	155.52 Mbit/s	STM-1	84 DS1 or 3 DS3	63 E1 or 1 E4
STS-12, OC-12	622.08 Mbit/s	STM-4	336 DS1 or 12 DS3	252 E1 or 4 E4
STS-48, OC-48	2488.32 Mbit/s	STM-16	1344 DS1 or 48 DS3	1008 E1 or 16 E4
STS-192, OC-192	9953.28 Mbit/s	STM-64	5376 DS1 or 192 DS3	4032 E1 or 64 E4

Note: Although an SDH STM-1 has the same bit rate as the SONET STS-3, the two signals contain different frame structures.

STM = Synchronous Transport Module (ITU-T)

STS = Synchronous Transport Signal (ANSI)

OC = Optical Carrier (ANSI)

Table F-2. Non-Synchronous Hierarchies

ANSI Rate			ITU Rate		
Signal	Digital Bit Rate	Channels	Signal	Digital Bit Rate	Channels
DS0	64 kbit/s	1 DS0	64 kbit/s	64 kbit/s	64 kbit/s
DS1	1.544 Mbit/s	24 DS0	E1	2.048 Mbit/s	32 E0
DS2	6.312 Mbit/s	96 DS0	E2	8.448 Mbit/s	128 E0
DS3	44.7 Mbit/s	28 DS1	E3	34.368 Mbit/s	16 E1
	not defined		E4	139.264 Mbit/s	64 E1

SONET and SDH Hierarchies

SONET and SDH converge at SDH's 155 Mbit/s base level, defined as STM-1 or "Synchronous Transport Module-1." The base level for SONET is STS-1 (or OC-1) and is equivalent to 51.84 Mbit/s. Thus, SDH's STM-1 is equivalent to SONET's STS-3 ($3 \times 51.84 \text{ Mbit/s} = 155.5 \text{ Mbit/s}$). Higher SDH rates of STM-4 (622 Mbit/s), STM-16 (2.4 Gbit/s), and STM-64 (10 Gbit/s) have also been defined.

Multiplexing is accomplished by combining - or interleaving - multiple lower-order signals (1.5 Mbit/s, 2 Mbit/s, etc.) into higher-speed circuits (51 Mbit/s, 155 Mbit/s, etc.). By changing the SONET standard from bit-interleaving to byte-interleaving, it became possible for SDH to accommodate both transmission hierarchies. This modification allows an STM-1 signal to carry multiple 1.5 Mbit/s or 2 Mbit/s signals - and multiple STM signals to be aggregated to carry higher orders of SONET or SDH tributaries.

Glossary & ITU-T Standards

Three sets of terms are arranged at the beginning of this section because it is important to see that they are not equivalent terms, which is how they get used in normal discussions. They are:

Add/ Drop

The process where a part of the information carried in a transmission system is extracted (dropped) at an intermediate point and different information is inserted (added) for subsequent transmission. The remaining traffic passes straight through the multiplexer without additional processing.

Map/ Demap

A term for multiplexing, implying more visibility inside the resultant multiplexed bit stream than available with conventional asynchronous techniques.

Multiplex/ Demultiplex

Multiplex (MUX) - To transmit two or more signals over a single channel.

Demultiplex (DEMUX) - To separate two or more signals previously combined by compatible multiplexing equipment. Demultiplexing - A process applied to a multiplex signal for recovering signals combined within it and for restoring the distinct individual channels of the signals.

An alphabetical list of glossary terms follows.

Add/Drop Multiplexer (ADM)

A multiplexer capable of extracting and inserting lower-rate signals from a higher-rate multiplexed signal without completely demultiplexing the signal.

Administrative Unit (AU)

An Administrative Unit is the information structure which provides adaptation between the higher order path layer and the Multiplex Section layer. The Virtual Container (VC) plus the pointers (H1, H2, H3 bytes) is called the Administrative Unit (AU).

AIS (Alarm Indicating Signal)

A code sent downstream indicating an upstream failure has occurred.

AMI

Alternate Mark Inversion. The line-coding format in transmission systems where successive ones (marks) are alternatively inverted (sent with polarity opposite that of the preceding mark).

Analog Jitter Out

A signal that contains the demodulated jitter from a line or clock input.

ANSI

American National Standards Institute. A standards-setting, non-government organization, which develops and publishes standards for "voluntary" use in the United States.

Asynchronous

A network where transmission system payloads are not synchronized and each network terminal runs on its own clock.

Asynchronous Transfer Mode (ATM)

A multiplexing/switching technique in which information is organized into fixed-length cells with each cell consisting of an identification header field and an information field. The transfer mode is asynchronous in the sense that the use of the cells depends on the required or instantaneous bit rate.

Attenuation

Reduction of signal magnitude or signal loss, usually expressed in decibels.

AU-4

Virtual Container (VC) plus the Transport Overhead pointers.

AU-N

Administrative Unit-N; a discrete unit of the SDH payload carrying one or more VC-N

Automatic Protection Switching (APS)

The ability of a network element to detect a failed working line and switch the service to a spare (protection) line. 1+1 APS pairs a protection line with each working line. 1:N APS provides one protection line for every N working lines.

Backhauling

Cumbersome traffic management technique used to reduce the expense of multiplexing/demultiplexing.

Bandwidth

Information-carrying capacity of a communication channel. Analog bandwidth is the range of signal frequencies that can be transmitted by a communication channel or network.

Bidirectional

Operating in both directions. Bi-directional APS allows protection switching to be initiated by either end of the line.

Binary N-Zero Suppression (BNZS)

Line coding system that replaces N number of zeros with a special code to maintain pulse density required for clock recovery. N is typically 3, 6, or 8.

BIP-8 (Bit Interleaved Parity-8)

A method of error checking in SDH which allows in-service performance monitoring. For example, a BIP-8 creates eight-bit (one-byte) groups, then does a parity check for each of the eight bit positions in the byte.

B-ISDN (Broadband Integrated Services Digital Network)

A single ISDN network which can handle voice, data, and eventually video services.

Bit

One binary digit; a pulse of data.

Bit Error vs. Block Error

Error rate statistics play a key role in measuring the performance of a network. As errors increase, user payload (especially data) must be re-transmitted, or lost entirely.

Bit Error Rate (BER) - The number of bit errors detected in a unit of time, usually one second. Bit Error rate (BER) is calculated with this formula:

$$BER = \text{errored bits received} / \text{total bits sent.}$$

Block Error Rate (BLER) - One of the underlying concepts of error performance is the notion of Errored Blocks, i.e., blocks in which one or more bits are in error. A block is a set of consecutive bits associated with the path or section monitored by means of an Error Detection Code (EDC), such as Bit Interleaved Parity (BIP). Block Error rate (BLER) is calculated with this formula:

$$BLER = \text{errored blocks received} / \text{total blocks sent.}$$

Bit-Interleaved Parity (BIP)

A parity check that groups all the bits in a block into units (such as byte), then performs a parity check for each bit position in the group.

Bit-Stuffing

In asynchronous systems, a technique used to synchronize asynchronous signals to a common rate before multiplexing.

Bits per second (bit/s)

The number of bits passing a point every second. The transmission rate for digital information.

Broadband

Services requiring over 2 Mbit/s transport capacity.

CCITT

See ITU.

Channel

The smallest subdivision of a circuit that provides a type of communication service; usually a path with only one direction.

Circuit

A communications path or network; usually a pair of channels providing bi-directional communication.

Circuit Switching

Basic switching process whereby a circuit between two users is opened on demand and maintained for their exclusive use for the duration of the transmission.

Coding Violation (CV)

A transmission error detected by the difference between the transmitted line code and that expected at the receive end by the logical coding rules.

Concatenation

The linking together of various data structures, for example two channels joined to form a single channel. In SDH, a number (M) of TUs can be linked together to produce a concatenated container, M times the size of the TU. An example of this is the concatenation of five TU-2s to carry a 32 Mbit/s video signal, known as VC-2-5c. Once assembled, any concatenated VC structure is multiplexed, switched and transported through the network as a single entity.

Conformance Tests

Conformance Tests (also know as Standards Conformance Tests) are predefined tests that measure the performance of networks or network elements against established performance standards. SDH standards are defined in the ITU-T Recommendations.

CMI - Code Mark Inversion

Cyclic Redundancy Check (CRC)

A technique for using overhead bits to detect transmission errors.

Data Communications Channel (DCC)

Data channels in SDH that enable OAM communications between intelligent controllers and individual network nodes as well as inter-node communications.

dB

The symbol for decibels.

dBm

The symbol for power level in decibels relative to 1 mW.

Defect

A limited interruption in the ability of an item to perform a required function. Persistence of a defect can cause a failure.

Digital Cross-connect (DCS)

An electronic cross-connect which has access to lower-rate channels in higher-rate multiplexed signals and can electronically rearrange (cross-connect) those channels.

Digital Signal

An electrical or optical signal that varies in discrete steps. Electrical signals are coded as voltages, optical signals are coded as pulses of light.

E1, E2, E3, E4

Alternative names for the ITU-T 2 Mb/s, 8 Mb/s, 32 Mb/s, and 140 Mb/s tributary signals.

ES

Errored Second; measure of network or equipment performance

ETSI (European Telecommunications Standards Institute)

Organization responsible for defining and maintaining European standards, including SDH.

Failure

A termination of the ability of an item to perform a required function. A failure is caused by the persistence of a defect.

FEBE (Far End Block Error)

See Remote Error Indication (REI).

FERF (Far End Receive Failure)

See Remote Defect Indication (RDI).

FIFO

First-In First-Out; a type of data buffer

Fixed Stuff

A bit or byte whose function is reserved. Fixed stuff locations, sometimes called reserved locations, do not carry overhead or payload.

Floating mode

A virtual tributary mode that allows the VC synchronous payload envelope to begin anywhere in the VC. Pointers identify the starting location of the VC. VCs in different multiframes may begin at different locations.

Framing

Method of distinguishing digital channels that have been multiplexed together.

Frequency

The number of cycles of periodic activity that occur in a discrete amount of time.

Frequency Drift Rate

The rate of change of a line or clock frequency, measured in ppm/sec. A new measure of timing quality.

Fullband

A jitter filter range that includes the wideband range but extends the low-frequency cutoff to 10 Hz or below. This filter is useful when analyzing video timing quality.

Grooming

Consolidating or segregating traffic for efficiency.

HDB3

High Density Bipolar 3. A bipolar coding method that does not allow more than three consecutive zeros.

Highband

A jitter filter range that measures high-frequency jitter. The band pass filters are defined in ITU-T standards (where they are sometimes referred to as HP2 - LP1).

Highpass

The lower -3 dB corner frequency of a filter. The filter passes frequencies higher than this frequency.

Interleave

The ability of SDH to mix together and transport different types of input signals in an efficient manner, thus allowing higher-transmission rates.

ITU (International Telecommunications Union)

An agency of the United Nations responsible for the regulation, standardization, co-ordination and development of international telecommunications as well as the harmonization of national policies. It functions through international committees of telecommunications administrations, operators, manufacturers and scientific/industrial organizations.

Jitter

The short term variations of the significant instants of a timing signal from their ideal positions in time (where short term implies that these variations are of frequency greater than or equal to 10 Hz).

Jitter Hit

When peak-to-peak jitter crosses a predetermined threshold.

Jitter Tolerance

A conformance test that measures the susceptibility of a network element input to incoming jitter.

Jitter Transfer

A conformance test that measures the transfer of jitter from the input to the output of a network element.

Jitter Transfer Function

A graph that shows jitter gain as a function of jitter frequency.

Line Alarm Indication Signal (AIS)

A Line AIS is generated by Section Terminating Equipment upon Loss of Signal or Loss of Frame.

Line Coding Violation (CV)

The sum of the BIP errors detected at the Line layer. Line CVs are collected using the BIP codes in the B2 bytes of the Line Overhead.

Line Errored Second (ES)

A second during which at least one Line CV occurred, or a second during which the line was in the Line AIS state.

Line Overhead (LOH)

Controls the payload information using the section layer and provides alarm indications, error monitoring, and message signalling between two LTEs.

Line Severely Errored Second (SES)

A second with N or more Line CVs, or a second during which the line was in the Line AIS state. The value of N varies with the transmit rate, but corresponds to a 2×10^{-7} BER.

Locked Mode

A virtual tributary mode that fixes the starting location of the VC. Locked mode has less pointer processing than floating mode.

LOF

An acronym for Loss of Frame.

LOP

An acronym for Loss of Pointer.

LOS

An acronym for Loss of Signal.

Low Frequency Jitter

Jitter that crosses the wander threshold (approximately 0.1 Hz to 500 Hz). Low frequency jitter is often the result of pointer movement.

Lowpass

The upper -3 dB corner frequency of a filter. The filter passes frequencies lower than this frequency.

LTE

An acronym for Line Terminating Equipment.

Mapping

The process of associating each bit transmitted by a service into the SDH payload structure that carries the service. For example, mapping a E1 service into a SDH VC-12 associates each bit of the E1 with a location in the VC-12.

Multiframe

Any structure made of multiple frames. SDH has facilities to recognize multiframe at the E1 level and at the VC-n level.

Multiplex Section Alarm Indication Signal (MS-AIS)

MS-AIS is generated by Section Terminating Equipment (STE) upon the detection of a Loss of Signal or Loss of Frame defect, on an equipment failure. MS-AIS maintains operation of the downstream regenerators, and therefore prevents generation of unnecessary alarms. At the same time, data and orderwire communication is retained with the downstream Line Terminating Equipment (LTE).

Multiplex Section Remote Defect Indication (MS-RDI)

A signal returned to the transmitting Line Terminating Equipment (LTE) upon detecting a Loss of Signal, Loss of Frame, or MS-AIS defect. MS-RDI was previously known as Multiplex Section FERF.

Multiplex Section Overhead (MSOH)

18 bytes of overhead accessed, generated, and processed by MS terminating equipment. This overhead supports functions such as locating the payload in the frame, multiplexing or concatenating signals, performance monitoring, automatic protection switching and line maintenance.

Multiplexer

A device for combining several channels to be carried by a single physical channel.

Narrowband

Services requiring up to 2-Mbit/s transport capacity.

Network Element (NE) - In SDH, the five basic network elements are:

add/drop multiplexer;
broadband digital cross-connect;
wideband digital cross-connect;
flexible multiplexer; and,
regenerator.

Any device which is part of a SDH transmission path and serves one or more of the section, line and path-terminating functions.

OAM

Operations, Administration, and Maintenance. Also called OAM&P.

OAM&P (Operations, Administration, Maintenance, and Provisioning)

Provides the facilities and personnel required to manage a network.

Orderwire

A dedicated voice channel used by installers to expedite the provisioning of lines.

OOF

An acronym for Out of Frame.

OS (Operations System)

Sophisticated applications software that manages operation of the entire network.

OSI Seven-layer Model

A standard architecture for data communications. Layers define hardware and software required for multi-vendor information processing equipment to be mutually compatible. The seven layers from lowest to highest are: physical, link, network, transport, session, presentation, and application.

Output Jitter

A compliance test that measures the output jitter of a network or network element.

Overhead

Extra bits in a digital stream used to carry information besides traffic signals. Orderwire, for example, would be considered overhead information.

Packet Switching

An efficient method for breaking down and handling high-volume traffic in a network. A transmission technique that segments and routes information into discrete units. Packet switching allows for efficient sharing of network resources as packets from different sources can all be sent over the same channel in the same bitstream.

Parity check

An error-checking scheme which examines the number of transmitted bits in a block which hold the value of "one". For even parity, an overhead parity bit is set to either one or zero to make the total number of transmitted ones in the data block plus parity bit an even number. For odd parity, the parity bit is set to make the total number of ones in the block an odd number.

Path

A logical connection between a point where a service in a VC is multiplexed to the point where it is demultiplexed.

Path Overhead (POH)

Overhead accessed, generated, and processed by path-terminating equipment.

Path Terminating Equipment (PTE)

Network elements such as fibre optic terminating systems which can access, generate, and process Path Overhead.

Payload

The portion of the SDH signal available to carry service signals such as E1 and E3. The contents of a VC.

Payload Pointer

Indicates the beginning of a Virtual Container.

Payload capacity

The number of bytes the payload of a single frame can carry.

Plesiochronous

A network with nodes timed by separate clock sources with almost the same timing.

PLL

Phase-Locked Loop; method of timing recovery

Pointer

A part of the SDH overhead that locates a floating payload structure. AU-n pointers locate the payload. TU-m Pointers locate floating mode virtual tributaries. All SDH frames use AU pointers; only floating mode virtual containers use TU pointers.

Pointer Hit

When the line or clock frequency drift crosses a predetermined threshold.

Pointer Jitter

A measure of the jitter output of a network when specified pointer test sequences are applied to its input.

ppTIE

Peak-to-Peak Time Interval Error , a measure of wander

PRC (Primary Reference Clock)

In a synchronous network, all the clocks are traceable to one highly stable reference supply, the Primary Reference Clock (PRC). The accuracy of the PRC is better than ± 1 in 10^{11} and is derived from a cesium atomic standard.

Remote Alarm Indication (RAI)

A code sent upstream in a E-n network as a notification that a failure condition has been declared downstream. (RAI signals were previously referred to as Yellow signals.)

Remote Defect Indication (RDI)

A signal returned to the transmitting Terminating Equipment when the receiving Terminating Equipment detects a Loss of Signal, Loss of Frame, or AIS defect. RDI was previously known as FERF.

Remote Error Indication (REI)

An indication returned to a transmitting node (source) that an errored block has been detected at the receiving node (sink). This indication was formerly known as Far End Block Error (FEBE).

Remote Failure Indication (RFI)

A failure is a defect that persists beyond the maximum time allocated to the transmission system protection mechanisms. When this situation occurs, an RFI is sent to the far end and will initiate a protection switch if this function has been enabled.

Regenerator

Device that restores a degraded digital signal for continued transmission; also called a repeater.

rms

Root Mean Square; calculation often applied to power and noise measurements

SDH (Synchronous Digital Hierarchy)

The ITU-defined international networking standard whose base transmission level

is 155 Mbit/s (STM-1). SDH standards were first published in 1989 to address interworking between the ITU and ANSI transmission hierarchies.

SEC (Synchronous Equipment Clock)

G.813 slave clock contained within a SDH network element.

Section

The span between two SDH network elements capable of accessing, generating, and processing only SDH Section overhead.

Section Overhead

Nine columns of overhead accessed, generated, and processed by section terminating equipment. This overhead supports functions such as framing the signal and performance monitoring.

Section Terminating Equipment (STE)

Equipment that terminates the SDH Section layer. STE interprets and modifies or creates the Section Overhead.

SES

Severely Errored Second; measure of network performance

Slip

An overflow (deletion) or underflow (repetition) of one frame of a signal in a receiving buffer.

SONET (Synchronous Optical Network)

A standard for optical transport in the United States, Canada, Japan, Korea and Hong Kong that defines optical carrier levels and their electrically equivalent synchronous transport signals. SONET allows for a multi-vendor environment and positions the network for transport of new services, synchronous networking, and enhanced OAM&P.

SSM (Synchronisation Status Message)

Bits 5 to 8 of SDH overhead byte S1 are allocated for Synchronisation Status Messages. See further details on the assignment of bit patterns for byte S1 in the section of this primer on Multiplex Section Overhead.

Stuffing

see bit-stuffing

Synchronous

A network where transmission system payloads are synchronized to a master (network) clock and traced to a reference clock. A network where all clocks have the same long term accuracy under normal operating conditions.

Synchronous Equipment Timing Source (SETS)

A network equipment clock.

Synchronous Transport Module (STM)

A structure in the SDH transmission hierarchy. STM-1 is SDH's base-level transmission rate equal to 155 Mbit/s. Higher rates of STM-4, STM-16, and STM-64 are also defined.

TDEV

Time Deviation; a measure of wander

Through Mode

The ability to retransmit the incoming signal and manipulate its contents.

TIE

Time Interval Error is the time difference in nanoseconds between the nominal value of a line or clock period and the actual received period.

Tributary

The lower rate signal that is input to a multiplexer for combination (multiplexing) with other low rate signals to form a higher rate signal.

Tributary Unit (TU)

A Tributary Unit is an information structure which provides adaptation between the lower order path layer and the higher order path layer. It contains the Virtual Container (VC) plus a tributary unit pointer.

Tributary Unit Group (TUG)

Contains several Tributary Units.

UI

Unit Interval; a measure of jitter

UIpp

Unit Interval Peak-to-Peak; a common measure of jitter

UIrms

Unit Interval rms; a measure of jitter in line systems

Virtual Container (VC)

A signal designed for transport and switching of sub-SDH payloads.

Wander

The long term variations of the significant instants of a digital signal from their ideal position in time (where long term implies that these variations are of frequency less than 10 Hz).

Wideband

A jitter filter range that measures jitter over a wide range. The band pass filters are defined in ITU-T standards (where they are sometimes referred to as HP1 - LP1).

Yellow Signal

See Remote Alarm Indication (RAI).

SDH Standards for ITU-T

- F.750 (ITU-R)
Architectures, functional aspects of radio-relay systems for SDH-based networks
- ITU-T G.652
Characteristics of single-mode optical fibre cable.
- ITU-T G.691
Optical interfaces for single channel SDH systems with optical amplifiers, and STM-64 systems
- ITU-T G.692 (G.mcs draft)
Optical interfaces for multi-channel systems with optical amplifiers
- G.701
Vocabulary of digital transmission and multiplexing and PCM terms
- G.702
Digital Hierarchy bit rates
- ITU-T G.703
Physical / electrical characteristics of hierarchical digital interfaces
- G.704
Synchronous frame structures used at 1544, 6312, 2048, 8448 and 4476 kbit/s hierarchical levels
- G.706
Frame alignment and cyclic redundancy check (CRC) procedures relating to basic frame structures defined in Recommendation G.704
- ITU-T G.707
Synchronous Digital Hierarchy (SDH) bit rates
- G.772
Protected monitoring points provided on digital transmission systems
- G.780
Vocabulary of terms for SDH networks and equipment
- G.782
Types and general characteristics of SDH equipment
- ITU-T G.783
Characteristics of SDH Equipment Functional Blocks
- G.784
SDH management
- G.802
Interworking between networks based on different and speech coding laws

G.803

Architectures of transport networks based on the SDH

ITU-T G.813

Timing characteristics of SDH equipment slave clocks (SEC)

G.825

Control of jitter and wander in SDH

ITU-T G.826

Error performance parameters and objectives for international, constant bit rate digital paths at or above the primary rate

G.831

Management capabilities of transport network based on SDH

G.841

Types and characteristics of SDH network protection architectures

G.861

Principles and guidelines for the integration of satellite and radio systems in SDH

ITU-T G.957

Optical interfaces for equipments and systems relating to the synchronous digital hierarchy

ITU-T G.958

Digital line systems based on the Synchronous Digital Hierarchy for use on optical fibre cables

I.432

B-ISDN User -network interface - Physical layer specification

M.2101

Performance Limits for BIS and Maintenance of Int' SDH Paths and Multiplex Sections

O.150

General requirements for instrumentation for performance measurements on digital transmission equipment

O.181

Equipment to assess error performance on STM-N interfaces

SONET-related Standards

ANSI T1.101-1994 Synchronization Interface Standard

ANSI T1.102-1993 Digital Hierarchy – Electrical Interfaces

Bellcore GR-253-CORE

Bellcore GR-2918-CORE, Generic criteria for SONET Point to Point WDM Systems in the 1550nm Region

Bellcore GR-2918-ILR, Full Report of Non-Closed Issues for GR-2918-CORE

Index

-A-

- Accessories, 1-6
- Alarm Generation Menus, 3-20
- Applications, 2-14
 - Active Analysis Mode, 2-15
 - Active Through Mode Analysis, 2-16
 - Example - STM-16c Application, 2-17
 - Passive Monitoring, 2-14

-C-

- CLEI Code, 1-5

-D-

- Defaults, Factory, C-1

-E-

- Error Generation Menus, 3-29
 - B2 or B3 Error Inject, 3-31
 - Inject Random BER on one selectable channel, 3-32

-F-

- First-Time Operation, 1-8
- Front Panel, 2-1
 - Connections, 2-10
 - Display, Display Controls, Indicators, 2-2
 - Setup Menus, 2-2

-G-

- General Menus, 3-10
 - Error Log Display, 3-13
 - Menu & Measurement Refinements, 3-10
 - TX or RX Configurations, 3-12

-I-

- Inspection Test, Incoming, B-1

-J-

- J0 Trace, multi-byte, 3-23
- J0, J1 Trace Capture & Display, 3-26

-M-

- Measurement Controls, Indicators, 2-9
 - Run/Stop, 2-9
 - Pause/Resume, 2-9

-O-

- Overhead Menus, 3-22
 - Edit M1 Byte, 3-28

-R-

- Receiver, 2-7
 - Connectors, 2-7
 - Drop Select Key, 2-9
 - Overhead Key, 2-9
 - Status Indicators, 2-8
 - Tributary Select Key, 2-9
 - View History Key, 2-9

Index

Receiver Menus, 3-33

APS/ MSP, 3-44

ASCII Synchronization Messages -
S1 byte, 3-43

Error Measurements, 3-33

G.826, M.2101 Measurements, 3-40

Overhead Displays, 3-42

Pointers Information, 3-46

RX Drop Select, 3-47

RX Tributary Select, 3-44

RX Tributary - RX Channel Select, 3-46

Rear Panel

Connectors, 2-13

SYNC Output, 2-12

Laser Lockout, 2-12

Remote Interlock, 2-12

Remote Indicators (GPIB), 2-11

-S-

Safety Summary, ix

SDH Glossary, G-1

Setup Menus, 3-1

Auxiliary Setup, 3-8

Laser Menus, 3-4

Power Fail Recovery, 3-9

Report/ Test Time, 3-7

Store/Recall, 3-7

TX Event Trigger Output, 3-6

View Angle, 3-7

SONET for Reference, D-1

Specifications, SDH, A-1

-T-

Transmitter, 2-4

Alarm Key, 2-6

Connectors, 2-4

Error Key, 2-6

Mode Key, 2-5

Overhead Key, 2-6

Status Indicators, 2-5

Tributary, Input Select Keys, 2-5

Transmitter Menus, 3-14

External Clock Synchronization, 3-16

Illegal Mode, 3-19

Input Select, 3-18

PRBS Mappings, 3-17

Tributary Select, 3-18

TX Source Mode, 3-14