



Agilent J1981A/B VQT Portable Analyzer

Setup Guide



Notices

Copyright © 2002 Agilent Technologies, Inc.
All rights reserved.

No part of this manual may be reproduced in any form or by any means (including electronic storage and retrieval or translation into a foreign language) without prior agreement and written consent from Agilent Technologies, Inc. as governed by United States and international copyright laws.

Manual Part Number

5971-2942

Edition

Third edition, June 2002

Software version 4.2

Printed in Singapore

Trademarks

Microsoft ® is a U.S. registered trademark of Microsoft Corporation.

Windows ® and MS Windows ® are U.S. registered trademarks of Microsoft Corporation.

Product Support

Call your local Agilent Technologies representative, or:

Tel: 1-800-452-4844

Fax: 303-754-4802

or call your local Agilent Sales and Service Office.

Web:

www.agilent.com/comms/onenetworks

Documentation Warranty

The material contained in this document is subject to change without notice. Agilent Technologies makes no warranty of any kind with regard to this material, including, but not limited to, the implied warranties of merchantability and fitness for a particular purpose. Agilent Technologies shall not be liable for errors contained herein or for incidental or consequential damages in connection with the furnishing, performance, or use of this material.

Warranty

A copy of the specific warranty terms applicable to your product and replacement parts can be obtained from your local Sales and Service Office.

Technology Licenses

The hardware and/or software described in this document are furnished under a license and may be used or copied only in accordance with the terms of such license.

Restricted Rights Legend

If Software is for use in the performance of a U.S. Government prime contract or subcontract, Software is delivered and licensed as "Commercial computer software" as defined in DFAR 252.227-7014 (June 1995), or as a "commercial item" as defined in FAR 2.101(a) or as "Restricted computer software" as defined in FAR 52.227-19 (June 1987) or any equivalent agency regulation or contract clause. Use, duplication or disclosure of Software is subject to Agilent Technologies' standard commercial license terms, and non-DOD Departments and Agencies of the U.S. Government will receive no greater than Restricted Rights as defined in FAR 52.227-19(c)(1-2) (June 1987). U.S. Government users will receive no greater

than Limited Rights as defined in FAR 52.227-14 (June 1987) or DFAR 252.227-7015 (b)(2) (November 1995), as applicable in any technical data.

ISO 9001 Certification

Produced to ISO 9001 international quality system standard as part of Agilent Technologies' objective of continually increasing customer satisfaction through improved process control.

CAUTION

A **CAUTION** notice denotes a hazard. It calls attention to an operating procedure, practice, or the like that, if not correctly performed or adhered to, could result in damage to the product or loss of important data. Do not proceed beyond a **CAUTION** notice until the indicated conditions are fully understood and met.

WARNING

A **WARNING** notice denotes a hazard. It calls attention to an operating procedure, practice, or the like that, if not correctly performed or adhered to, could result in personal injury or death. Do not proceed beyond a **WARNING** notice until the indicated conditions are fully understood and met.

General Safety Precautions

Before you use this instrument, read the "General Safety Precautions" and "Additional Safety Information" sections. Failure to comply with the precautions or with specific warnings in this book violates safety standards of design, manufacture, and intended use of this instrument. Agilent Technologies assumes no liability for the customer's failure to comply with these requirements.

WARNING This product is a Safety Class I instrument with a protective earth terminal.

WARNING For protection from electric shock hazard, power cord ground must not be defeated.

Operating Restrictions

The following general safety precautions must be observed during all phases of operation, service, and repair of this instrument. Failure to comply with these precautions with specific warnings in this manual violate safety standards of design, manufacture, and intended use of this instrument.

Grounding

To minimize shock hazard, the instrument chassis and cabinet must be connected to an electrical ground. The instrument is equipped with a three-conductor AC power cable compatible with an approved three-contact electrical outlet. The power cord jack and mating plug of the power cord must meet International Electrotechnical Commission (IEC) safety standards.

Environment

Do not operate the instrument in the presence of flammable gases or fumes. Operation of any electrical instrument in

such an environment constitutes a definite safety hazard.

Service and Adjustment

Dangerous voltages exist within this instrument. Service and adjustment of this instrument is to be performed only by trained service personnel.

Do not replace components with the power cable connected. Dangerous voltages may be present even when the power cable is disconnected.

Do not perform internal servicing or adjustment unless another person, capable of rendering first aid and resuscitation is present.

Hazardous Material

Should the LCD be damaged the liquid crystal material can leak. Avoid all contact with this material, especially swallowing. Use soap and water to thoroughly wash all skin and clothing contaminated with the liquid crystal material.

Unauthorized Service

The installation of substitute parts or the installation of any instrument modification not authorized by Agilent Technologies is specifically forbidden. The performance of such unauthorized service can negate the instrument warranty or any maintenance agreements.

Return the instrument to an Agilent Sales and Service Office for authorized service and repair.

Electric Shock Hazard

Do not remove the system covers. To avoid electric shock, use only the supplied power cords and connect only to properly grounded (3-pin) wall outlets.

Explosion Hazard

Do not operate in the presence of flammable gases.

Fire Hazard

For continued protection against fire hazard replace only with fuse of same type and rating.

Cleaning

To clean the product, use a damp cloth moistened with a mild solution of soap and water. Do not use harsh chemicals. Do not let water get into the product.

Product Damage

Do not use this product when the product shows visible damage, fails to perform, has been stored in unfavorable conditions, or has been subject to severe transport stresses.

Whenever this product has become damaged or wet, make the product inoperative and secure it against any unintended operation. Contact your nearest Agilent Sales office for assistance.



Instruction book symbol - the product will be marked with this symbol when it is necessary for the user to refer to the instruction book in order to protect against damage.



A product marked with this symbol indicates it is a laser product. When necessary, this symbol will be included in the instruction book for the user to refer to in order to protect against personal injury and/or correct product handling.



Indicates potential for electrical shock.

This is an Installation Category II product.

This is a Pollution Degree 2 product.

This product is designed for indoor use only.

FCC Part 68 Disclaimer

This equipment must not be connected to the telephone network unless it is connected through protective circuitry that is registered pursuant to Part 68 of the Federal Communications Commission rules.

ATTENTION. USE OF THE SOFTWARE IS SUBJECT TO THE AGILENT TECHNOLOGIES SOFTWARE LICENSE TERMS SET FORTH BELOW. USING THE SOFTWARE INDICATES YOUR ACCEPTANCE OF THESE LICENSE TERMS. IF YOU DO NOT ACCEPT THESE LICENSE TERMS, YOU MAY RETURN THE SOFTWARE FOR A FULL REFUND. IF THE SOFTWARE IS BUNDLED WITH ANOTHER PRODUCT, YOU MAY RETURN THE ENTIRE UNUSED PRODUCT FOR A FULL REFUND.

AGILENT TECHNOLOGIES SOFTWARE LICENSE TERMS

The following License Terms govern your use of the accompanying Software unless you have a separate signed agreement with Agilent Technologies.

License Grant. Agilent Technologies grants you a license to Use one copy of the Software. "Use" means storing, loading, installing, executing or displaying the Software. You may not modify the Software or disable any licensing or control features of the Software. If the Software is licensed for "concurrent use", you may not allow more than the maximum number of authorized users to Use the Software concurrently.

Ownership. The Software is owned and copyrighted by Agilent Technologies or its third party suppliers. Your license confers no title to, or ownership in, the Software and is not a sale of any rights in the Software. Agilent Technologies's third party suppliers may protect their rights in the event of any violation of these License Terms.

Copies and Adaptations. You may only make copies or adaptations of the Software for archival purposes or when copying or adaptation is an essential step in the authorized Use of the Software. You must reproduce all copyright notices in the original Software on all copies or adaptations. You may not copy the Software onto any public network.

No Disassembly or Decryption. You may not disassemble or decompile the Software unless Agilent's prior written consent is obtained. In some jurisdictions, Agilent's consent may not be required for limited disassembly or decompilation. Upon request, you will provide Agilent Technologies with reasonably detailed information regarding any disassembly or decompilation. You may not decrypt the Software unless decryption is a necessary part of the operation of the Software.

Transfer. Your license will automatically terminate upon any transfer of the Software. Upon transfer, you must deliver the Software, including any copies and related documentation, to the transferee. The transferee must accept these License Terms as a condition to the transfer.

Termination. Agilent Technologies may terminate your license upon notice for failure to comply with any of these License Terms. Upon termination, you must immediately destroy the Software, together with all copies, adaptations and merged portions in any form.

Export Requirements. You may not export or re-export the Software or any copy or adaptation in violation of any applicable laws or regulations.

U.S. Government Restricted Rights. The Software and any accompanying documentation have been developed entirely at private expense. They are delivered and licensed as "commercial computer software" as defined in DFARS 252.227-7013 (Oct 1988), DFARS 252.211-7015 (May 1991) or DFARS 252.227-7014 (Jun 1995), as a "commercial item" as defined in FAR 2.101(a), or as "Restricted computer software" as defined in FAR 52.227-19 (Jun 1987)(or any equivalent agency regulation or contract clause), whichever is applicable. You have only those rights provided for such Software and any accompanying documentation by the applicable FAR or DFARS clause or the Agilent standard software agreement for the product involved.

Microsoft Products. Microsoft Products are licensed to you under the Microsoft End User License Agreement (EULA) contained in the Microsoft documentation. Microsoft Products are covered under the Agilent Technologies warranty Statement supplied with the Agilent Products. The warranties in the Microsoft Documentation will not apply.

Information Map

Voice quality tester (VQT) devices and the measurements that run on them are described in these documents:

- The *Agilent VQT Getting Started Guide* describes the VQT software, the overall test system architecture, and the measurements. Also see the online Help.
- The *VQT Network Server Setup Guide* describes the setup and use of the VQT Network Server device.
- The *VQT on the Agilent Advisor Setup Guide* describes the setup of the Agilent Advisor and use of the VQT software on the Advisor.
- The *VQT Responder Setup Guide* describes the setup and use of the VQT Responder device.

To get started with your new VQT Portable Analyzer, start with this book to set up, install, and configure it for operation. Then go to the *Agilent VQT Getting Started Guide* or the Help for detailed information about running VQT measurements and tools.

Contents

1 Introduction

- Introduction to the Agilent VQT Portable Analyzer 10
- Overview of the VQT Portable Analyzer in a VQT Test System 13

2 Getting Started

- Overview 18
- Planning Your VQT Testing Strategy 21
- Setting Up the VQT Portable Analyzer 23
 - Setting Up a New VQT Portable Analyzer 23
 - Upgrading an Existing VQT Portable Analyzer 28
- Configuring for Remote or Distributed Testing 32
 - Configuring the VQT Portable Analyzer's Network IP Connection 32
 - Configuring the VQT Portable Analyzer as a Server 33
 - Setting Up a Controlling PC 40
- Connecting to the Network Under Test 44
 - FXO and E&M Connections 45
 - Ground Connections 49
 - T1 and E1 Connections 53
 - 10/100 Ethernet Connections 57
- Starting the VQT Software and Using the Server Setup Tool 60

A Specifications and Operating Conditions

- FXO and E&M Card Specifications 66
 - FXO Ports 66
 - E&M Ports 66
- T1 and E1 Card Specifications 67
 - T1 Ports 67

Contents

	E1 Ports	67
	10/100 Ethernet NIC Specifications	69
	PCI 10/100 Ethernet Port (built-in)	69
	Operating Conditions	72
B	Installing and Configuring the NICs	
	Overview	74
	Installation Instructions	75
	Installing the Optional PCMCIA Card	75
	Configuring the Second NIC	77
C	Regulatory Information	
	Regulatory Compliances	80
	Declaration of Conformity	81
D	Software and Operating System Recovery	
	Reinstalling Windows NT 4.0	84
	Re-installing the VQT Software	86

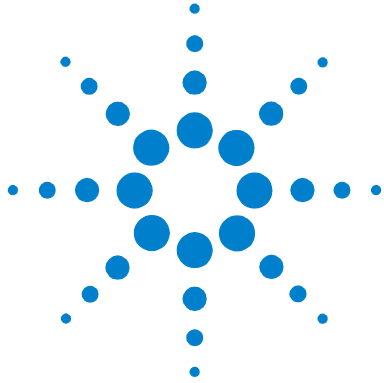

1 Introduction

Introduction to the Agilent VQT Portable Analyzer 10

Overview of the VQT Portable Analyzer in a VQT Test System 13



1 Introduction

Introduction to the Agilent VQT Portable Analyzer

The Agilent VQT Portable Analyzer (J1981A/B) is a rugged, portable, and powerful PC running Windows NT. Standard features include two PCMCIA card slots, a CD-RW drive (read/write CD drive), a high-density floppy drive, and speakers.

NOTE

To take full advantage of the CD-RW drive, the VQT Portable Analyzer provides the Easy CD Creator software package. It is suggested that you use the 4X speed when creating your own CDs.

It can be locally or remotely controlled to perform voice quality measurements over FXO, E&M, T1 or E1, and 10/100 interfaces. It is equipped with:

- A custom analog signal card that interfaces directly with FXO and E&M devices to provide analog measurements to the VQT software, which displays them in multiple formats.
- Either a T1 or E1 interface card that provides the connection to the T1 or E1 network and the signalling capacity for setting up, tearing down, and maintaining calls.
- A single internal 10/100baseT Ethernet NIC that can provide the connection to the IP network for both control and voice quality testing purposes.



Using the VQT Portable Analyzer, you can:

- Test voice-over-packet (VoP) quality, gather and compare end-to-end voice quality information, augment other traditional telephony test suites (such as TIMS), and access and run VQT tests from a remote location.
- Measure fundamental voice quality metrics such as clarity, delay, echo, and signal loss; evaluate VoP operations such as voice activity detection (VAD) and DTMF tone detection; and use tone and noise generators and wave file playback and record test tools.
- Implement a client/server architecture for stand-alone or remote test systems, and perform voice quality testing across most TCP/IP networks using multiple hardware platforms.

You may need other components to implement a VQT test system using a VQT Portable Analyzer:

VQT Software

The VQT software comes pre-installed on new VQT Portable Analyzers, but if you have an existing VQT Portable Analyzer, you will have to install or upgrade the VQT software. (These instructions are provided later.) Depending on where your VQT Portable Analyzer is installed, the testing you plan to perform, and the options you have installed, the VQT software can be run as one or more clients, each controlling a VQT server, or as a server being controlled by a client. (The VQT system architecture is described later.) To enable remote operation, you must purchase and enter the Agilent VQT Client Software License (J1979A). It enables the VQT Portable Analyzer to manage VQT servers and provides an individual client window for each server when performing remote testing. If the VQT Portable Analyzer will be controlled by another device, that device must have the client software license enabled.

For detailed operating instructions, see the Help or refer to the *Agilent VQT Getting Started Guide*. See “Entering the Client License Key” on page 43 to enter the client license.

Optional PCMCIA 10/100 Ethernet Interface

In addition to the standard Ethernet NIC installed in the VQT Portable Analyzer’s chassis, you can also order and install an additional PCMCIA 10/100 Ethernet interface. With two NICs installed, you have access to more control and voice quality testing functionality. For example, you can use one NIC

1 Introduction

interface for control and the optional, user-installed NIC to run voice quality testing. The supported PCMCIA card is a Xircom Cardbus 10/100 Ethernet card (J5480A). To fully use the 10/100 Ethernet interfaces, you must purchase and enable the Ethernet VoIP Interface license (J5479A). When the VQT is enabled with this license, you can perform voice quality measurements across IP networks, including SIP and H.323.

The connection and configuration options are described in Chapter 2. See Appendix B to install the optional NIC. Information about enabling the Ethernet VoIP license is in “Starting the VQT Software and Using the Server Setup Tool” on page 60.

Overview of the VQT Portable Analyzer in a VQT Test System

A VQT Portable Analyzer test system does two things:

- It places and/or answers one or more telephone calls to establish voice connections. The voice connection, the transmission media, and the equipment then become components of the system under test.
- Once the VQT system has established at least one telephone call, it can transmit audio test signals onto that call and measure how those signals are affected by travel through the system under test.

For the VQT system to measure voice quality, it must control one or both ends of a voice circuit (depending on the measurement) and be able to actively transmit, and in many cases receive, specific test signals onto, and from, that circuit.

The VQT Portable Analyzer can be controlled using its own keyboard and monitor; however, it can also be remotely controlled across an IP network by another VQT device or an appropriately connected and configured desktop or laptop PC.

1 Introduction

The VQT Portable analyzer can be used to perform single-server voice quality testing where measurements are run between its own ports or channels, as shown:

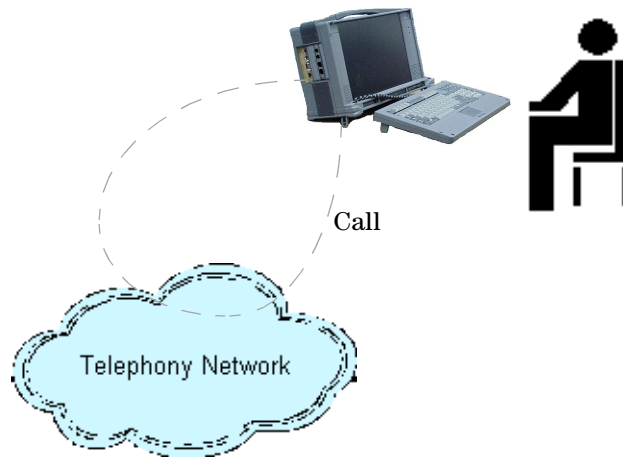

The VQT Portable Analyzer can act as both end points of the call for most interfaces. When using the 10/100 Ethernet interface, you need a VQT device at both ends of the call.

The VQT Portable Analyzer can also be part of a larger remote or distributed test environment where voice quality measurements are run between multiple VQT devices, as shown:

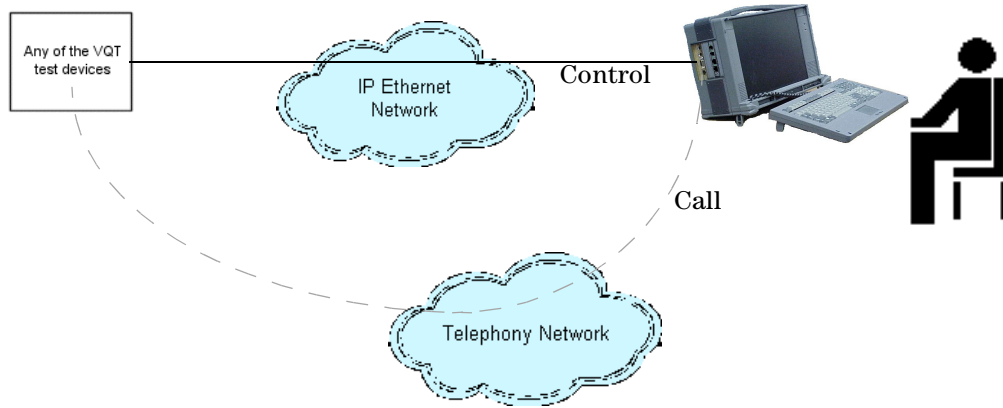

With the client license key enabled, the VQT Portable Analyzer can control other VQT devices in a VQT test system.

1 Introduction

A VQT Portable Analyzer can also be remotely controlled across the IP network by an appropriately configured desktop or laptop PC running the VQT software, as shown:

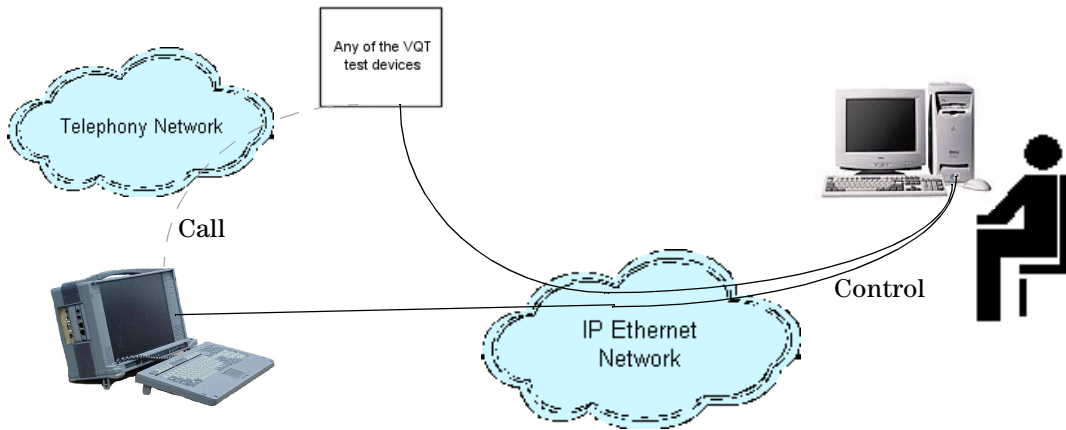

The controlling device can manage multiple VQT servers across an IP network. Those VQT servers can run voice quality tests and the measurement results will be sent to the controlling PC for display.

See the *Agilent VQT Getting Started Guide* and the Help for a full description of the VQT test system and how the VQT Portable Analyzer can play a role.

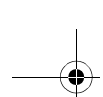

2 Getting Started

- Overview 18
- Planning Your VQT Testing Strategy 21
- Setting Up the VQT Portable Analyzer 23
- Configuring for Remote or Distributed Testing 32
- Connecting to the Network Under Test 44
- Starting the VQT Software and Using the Server Setup Tool 60



2 Getting Started

Overview

This chapter describes how to set up and configure the VQT Portable Analyzer to perform voice quality measurements. The testing strategies described here also help you decide how and where to use the VQT Portable Analyzer within a VQT test system. The steps are summarized first and then described in more detail later. Once you become more familiar with this powerful voice quality test tool, you can deviate from the procedures outlined here to suit your own test needs.

Refer to the *Agilent VQT Getting Started Guide* or the Help for information on running voice quality measurements and interpreting their results.

Step 1. Plan your network test strategy (see page 21).



- ✓ Identify Target Test Circuits
- ✓ Determine Test Schedule
- ✓ Contact Network Administrator
- Set up Test Bed
- Purchase Test Gear
- Install Test Gear

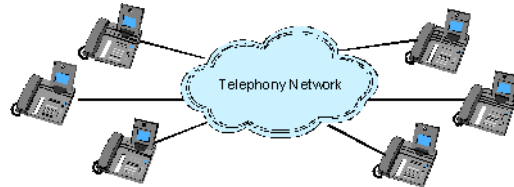

VQT Devices



- ✓ Identify Target Test Circuits
- ✓ Determine Test Schedule
- ✓ Contact Network Administrator
- Set up Test Bed
- Purchase Test Gear
- Install Test Gear

Step 2. Set up the VQT Portable Analyzer (see page 23).



Step 3. Configure the VQT Portable Analyzer (see page 32).

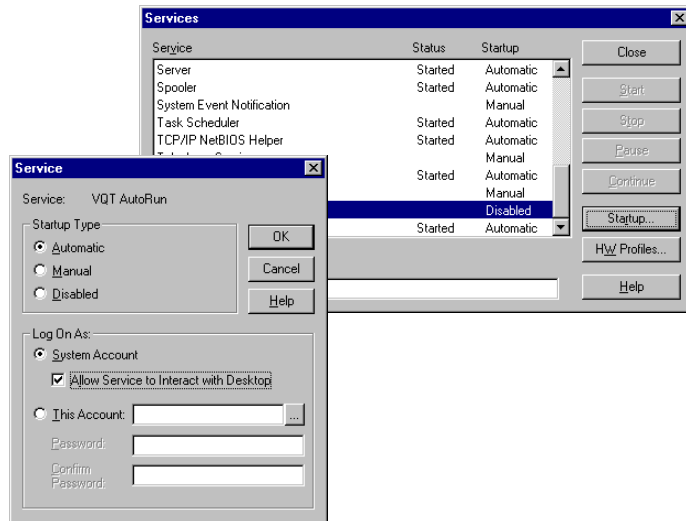

2 Getting Started

Step 4. Connect the VQT Portable Analyzer to the network under test (see page 44).

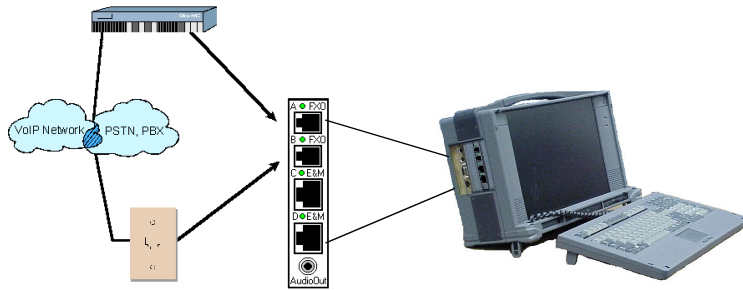

Step 5. Start the VQT software on the controlling PC or VQT Portable Analyzer (see page 60).

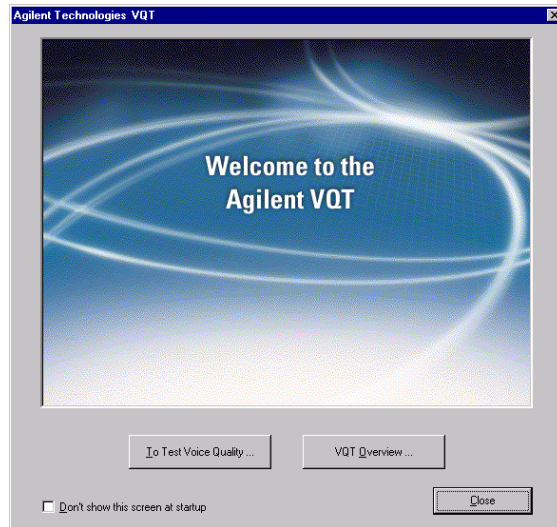

The remaining sections of this chapter describe each of the previous steps in detail.

Planning Your VQT Testing Strategy

While you may have done some of the planning as part of your purchasing process, it is a good idea to spend some time reviewing how you plan to deploy your VQT system. Consider the following:

- **Testing Roles of VQT Equipment** – The VQT Portable Analyzer can be locally controlled as a stand-alone test device. As part of a VQT test system, the VQT Portable Analyzer can be remotely controlled by another VQT Portable Analyzer, an Advisor, or a desktop or laptop PC. The VQT Portable Analyzer can also remotely control other VQT devices such as VQT Network Servers, VQT Responders, Advisors, and other VQT Portable Analyzers. The role each device will play determines how you set up your equipment (such as physical location and connections, software configuration, and voice network management processes) both initially and later as testing needs and roles change.
- **IP Management Network vs. Network Under Test** – Remember the distinction between the IP management network and the network under test. For remotely controlled VQT test equipment, or VQT devices that will be used as controlling PCs, TCP/IP network connections need to be physically near the connections you make to the network under test. It is also possible that the management network and the network under test would be the same network. In addition, it may be necessary to work with Network Administrators when configuring and connecting VQT equipment to the IP network. You might need to obtain various permissions and IP addresses, and react to other network conditions.

2 Getting Started

- **Logistical Concerns** – When performing remote or distributed testing, VQT devices will likely be installed in widely dispersed locations. For this reason, you will need to coordinate the installation and configuration of each component. For existing VQT equipment, software (and possibly hardware) upgrades are required. For all involved equipment, IP connectivity must be configured and arranged, and server security may need to be coordinated. Once the initial setup has been performed, IP and network under test connections must be verified. Subsequent changes to configurations and software may have to be done on location, and should be allowed for in your network test planning.

Setting Up the VQT Portable Analyzer

This section describes how to set up your new VQT Portable Analyzer or how to upgrade your existing one for locally controlled, single-server testing. If you plan to use the VQT Portable Analyzer in a remote or distributed environment, you should also read “Configuring for Remote or Distributed Testing” on page 32.

Setting Up a New VQT Portable Analyzer

Unpack, set up, and turn on the VQT Portable Analyzer

Since the VQT Portable Analyzer is a self-contained personal computer running Windows NT, you simply need to open it up, attach the power cable (and perhaps a mouse), and turn it on. See the following diagram.

You can connect a serial mouse to the Com 1 port on the back of the chassis before turning on the VQT Portable Analyzer. The instructions to configure the mouse are provided later.

The built-in 10/100 Ethernet NIC, analog signal acquisition ports, or the T1/E1 ports are located on the left side of the chassis.



Two PCMCIA ports are located below the display.

2 Getting Started

Use the following steps to set up your VQT Portable Analyzer:

- 1 Open the VQT Portable Analyzer keyboard (it latches at the top) and ensure the keyboard cable is connected.
- 2 You can extend the legs underneath the VQT Portable Analyzer to make it tilt back.
- 3 Connect the power cable to the right side of the chassis.
- 4 Turn it on using the power switch on the right side of the chassis.

NOTE

You can adjust the audio volume of the VQT Portable Analyzer using the audio level in the Windows Volume Control dialog box. Double-click the speaker icon in the status bar to access that dialog box.

Use the following steps to configure the basic information necessary for the Windows NT operating system. These steps are necessary only for the first-time startup of a new VQT Portable Analyzer.

NOTE

When a VQT Portable Analyzer is turned on, you are required to log in with a user name and password. Any user of the VQT software must log in to the VQT's Windows NT environment such that they have administrative privileges. It is not necessary to log in specifically as the administrator.

- 1 When asked for your name and organization, type the name of the primary user and organization. This information is not used in later configuration or setup tasks; it is strictly for Windows NT's record-keeping purposes.
- 2 When prompted for the registration number, use the Certificate of Authenticity number included in the materials provided with your VQT Portable Analyzer.
- 3 When prompted for the computer name, type a name that uniquely identifies the VQT Portable Analyzer within the domain to which it is attached. This name will also be used to identify it within the VQT test system.

- 4 When prompted to set up the Administrator account, use a password that is easily remembered within your organization.

NOTE

After the Administrator account is established, you can create other user profiles and login accounts for normal VQT operation.

If you installed a serial mouse, use the following instructions to configure Windows NT to use it.

Configuring an Optional Serial Mouse

After you have finished the initial Windows NT setup, you can configure the VQT Portable Analyzer to use a serial mouse. The instructions in this section assume you have connected the mouse. If not, turn off the VQT Portable Analyzer, connect the serial mouse to the Com 1 port on the back of the chassis, and turn on the VQT Portable Analyzer. Use the following instructions to configure Windows NT to use the mouse.

- 1 Once Windows NT has started, a message will display indicating that new hardware has been found. Respond to the prompts by clicking OK.
- 2 When prompted for the file location, type `c:\i386` and click OK.
- 3 Restart the computer when prompted.

Once the restart is complete and the Windows NT desktop appears, your mouse should be operational. After this setup, if the VQT Portable Analyzer is started without the serial mouse connected, warning messages will appear, but these messages do not adversely affect the operation of the VQT Portable Analyzer.

Setting Up an Optional Printer

The VQT Portable Analyzer is not delivered with a default printer or printer configuration, but you can install a printer if you want one. This section contains only brief instructions for installing an optional printer with your VQT Portable Analyzer.

2 Getting Started

NOTE

These instructions assume you are setting up a printer that is directly supported by Windows NT. If your printer is not supported by Windows NT, use the manufacturer's instructions to install it.

To set up a printer, connect the printer cable to the parallel port at the back of the chassis. Then, use the normal Windows printer installation process accessed via the Control Panel. When prompted for drivers, type `c:\i386` and access the drivers installed on the VQT Portable Analyzer hard drive.

Configuring the Internal NIC

The VQT Portable Analyzer is delivered with a single 10/100baseT Ethernet NIC installed in its chassis. You can order and install an additional PCMCIA 10/100 Ethernet interface (product number J5480A). See the following:

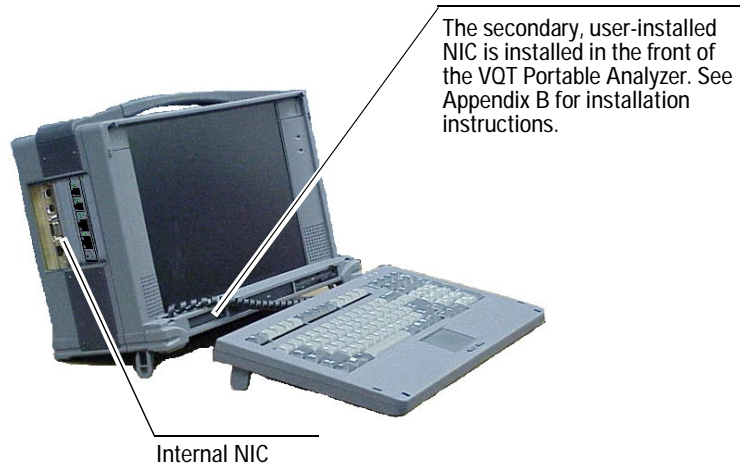

NOTE

The internal and PCMCIA installation instructions are identical for both the J1981A and the J1981B with the exception of the driver file choice. For a J1981B, select the Intel(R) PRO Adapter driver; for a J1981A, select the PCI Fast Ethernet Adapter driver.

See Appendix B for information about configuring the internal and secondary NICs. Use the following steps to configure the internal NIC:

- 1 Ensure that the VQT Portable Analyzer is connected to the network and turned on.
- 2 Right-click the Network Neighborhood icon on the desktop and select Properties from the menu that appears. The Network Configuration dialog box appears indicating that the NT Networking has not been installed and asking if you want to install it.
- 3 Click Yes. The Network Setup Wizard dialog box appears.
- 4 Ensure the Wired to the network option is selected then click Next. The next Network Setup Wizard dialog box appears.
- 5 Click the Select from list button. The Select Network Adapter dialog box appears.
- 6 Click the Have Disk button. The Insert Disk dialog box appears.
- 7 Type `c:\i386` in the field and click OK. The Select OEM Option dialog box appears with the internal NIC listed and selected.
- 8 Click OK. The Network Setup Wizard appears again with your card listed and selected.
- 9 Click Next and the next Network Setup Wizard dialog box appears with the TCP/IP Protocol selected.
- 10 Click Next and the next Network Setup Wizard dialog box appears listing the services that will be installed by the system.
- 11 Accept the defaults and click Next. The next Network Setup Wizard appears with information about the installation.

2 Getting Started

12 Click Next. The Windows NT Setup dialog box appears indicating it will look for the card setup files.

13 Type `c:\i386` in the field and click the Continue button. The TCP/IP Setup dialog box appears asking if you wish to use DHCP.

NOTE

Ensure that you are using the information provided by your Network Administrator for these steps. Your Network Administrator's information may prompt changes to some of these instructions. These changes cannot be accounted for in this document.

14 Click Yes. The next Network Setup Wizard dialog box appears listing the network bindings.

15 Accept the defaults and click Next. The next Network Setup Wizard dialog box appears indicating the network will be started.

16 Accept the defaults and click Next. The next Network Setup Wizard dialog box appears again indicating that you can select whether the computer will be part of a workgroup or domain.

17 Accept the defaults and click Next. You are prompted to restart the computer.

18 Click Finish to restart your computer. The Network settings Change dialog box appears.

19 Click Yes to verify the restart.

See "Configuring for Remote or Distributed Testing" on page 32 for instructions to configure the NICs.

Upgrading an Existing VQT Portable Analyzer

You can upgrade an existing VQT Portable Analyzer to the latest software version or to add new acquisition hardware. This section describes both of these processes.

CAUTION

Do not install the Xircom Cardbus 10/100 Ethernet using the installation CD included with the Xircom card. The correct drivers are included on the VQT Software Upgrade CD.

You will install the VQT software upgrade first to ensure that the correct 10/100 card drivers are installed.

Upgrading the VQT Software

Use the following instructions to upgrade the VQT software on an existing VQT Portable Analyzer.

- 1 Place the VQT Software Upgrade CD (J1978A) into the CD-ROM drive of the VQT Portable Analyzer.
- 2 Click the Start button in the Windows NT desktop and select Run. The Run dialog box appears.
- 3 Type `d:\setup.exe` in the field and click OK. (Replace “d” with the drive letter assigned to the CD-ROM drive on the VQT Portable Analyzer, if different.)

2 Getting Started

During the installation, you will be prompted to select the VQT components you want to install on the VQT Portable Analyzer. See the following image.

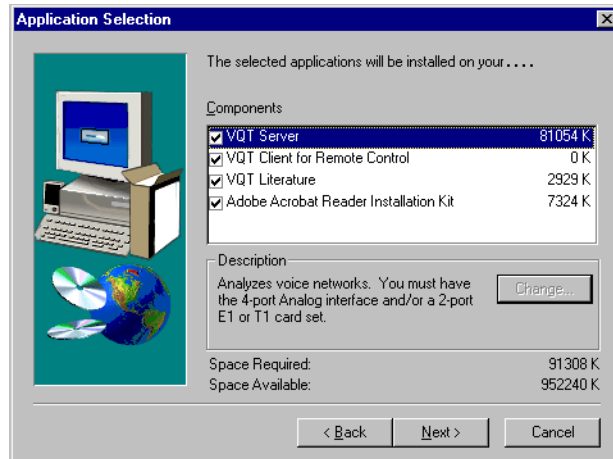

- Select the VQT Server option when you want this device to be controlled by another VQT server or controlling desktop or laptop PC. Do not select this option on a controlling PC.
- Select the VQT Client for Remote Control option if you plan to use this device to control other VQT servers within the test system. This option requires a client license key, which you will have to type later when you run the software. Do not select this option on a device to be controlled.
- Select VQT Literature to install the documentation
- Select Adobe Acrobat Reader Installation Kit to ensure you can view the VQT documentation.

Upgrading the Hardware (Test Interfaces)

If you have an existing VQT Portable Analyzer that has only analog, or T1 or E1 testing capabilities, you can upgrade the hardware to include these other interfaces in addition to upgrading the hardware to include 10/100 Ethernet testing capabilities.

NOTE

Remember, VQT Portable Analyzers are generally equipped with a single, built-in 10/100 Ethernet NIC, and you can order and install a second 10/100 Ethernet NIC. See Appendix B for the instructions to accomplish that installation.

To fully use the 10/100 Ethernet interface, you must have the 10/100 Ethernet VoIP license (J5479A). For detailed installation instructions to install the hardware upgrades, refer to the *Upgrade Kit Installation Guide*. If you do not wish to perform the upgrade after reading the *Upgrade Kit Installation Guide*, you can return the equipment and the unopened Upgrade Kit to your local Agilent Service Center. Your local Agilent Service Center will provide upgrade services.

2 Getting Started

Configuring for Remote or Distributed Testing

If you plan to control your VQT Portable Analyzer from its own keyboard and monitor and use it to perform single-server testing, go to “Connecting to the Network Under Test” on page 44 for physical connection information. Your VQT Portable Analyzer can be incorporated into a VQT test system in multiple roles:

- If you plan to use the VQT Portable Analyzer as a controlling PC or to remotely control it using another PC or VQT device, you must configure a VQT Portable Analyzer NIC for IP network connectivity and the role it will play. These configuration tasks are provided in this section.
- In addition, if you plan to use the VQT Portable Analyzer for 10/100 Ethernet voice quality testing, you need to configure the NIC for IP network connectivity. This configuration is the same for remote or distributed control as it is for 10/100 Ethernet testing. These configuration tasks are also provided in this section.

It is important that you consider what network you are going to use for each purpose and then configure the NIC accordingly. Remember, the VQT Portable Analyzer 10/100 Ethernet interfaces include a built-in 10/100baseT Ethernet NIC and an optional, user-installed, secondary PCMCIA NIC (product number J5480A).

Configuring the VQT Portable Analyzer’s Network IP Connection

The VQT Portable Analyzer is delivered with a single 10/100baseT Ethernet NIC installed in its cabinet. This card is referred to as the internal NIC. See Appendix B for information to configure both the internal NIC and the optional, second 10/100 Ethernet NIC. To ensure the VQT server communicates correctly with the IP network, it is recommended that you physically connect the 10/100 Ethernet ports to the control network and network under test prior to turning the VQT server on.

The VQT Portable Analyzer is delivered with no default networking configuration; however, to use the VQT Portable Analyzer in a remote or distributed test environment for 10/100 Ethernet voice quality testing or for other networking needs, you must set up the network connection.

Once the NIC is installed, you will want to connect the VQT Portable Analyzer to the IP network. The IP network connection must have the following characteristics:

- The connection must be 10/100 Ethernet
- It must use a standard Windows TCP/IP protocol stack

You can connect the NIC to an IP network LAN drop, hub, router, or switch using a 10/100 RJ-45 Ethernet Cable (product number 5065-0452).

NOTE

Before you set up the VQT Portable Analyzer (or desktop/laptop PC) for IP management network connectivity, contact your IP Network Administrator. You need to have specific information (such as IP addresses, subnet masks, default gateways) that may be used during the configuration process.

If you will use the VQT Portable Analyzer as a controlling PC in a VQT test system, go to “Setting Up a Controlling PC” on page 40.

Go to “Connecting to the Network Under Test” on page 44 for connection information on the different VQT Portable Analyzer interfaces.

Configuring the VQT Portable Analyzer as a Server

If you intend to install the VQT Portable Analyzer in a network POP (Point of Presence), in a remote test bed or lab, or at a customer site to be remotely controlled as a dedicated server, you will need to configure it accordingly.

Configuring the VQT Portable Analyzer for this type of operation consists of starting the VQT server processes that will respond to controlling PC commands. You can manually start

2 Getting Started

VQT server processes on the VQT Portable Analyzer or you can configure it to run these processes automatically each time it is turned on.

Use the following sections to configure the VQT Portable Analyzer to start manually or automatically as a VQT server.

Manually Starting the VQT Server Processes

Double-click the Start VQT Servers icon in the Windows NT desktop.

- OR -

Click the Windows Start button, point to Programs, point to Agilent VQT and click Start VQT Servers.

Two small dialog boxes appear showing the state of the current server processes and indicating whether users are connected to the server via VQT client software.

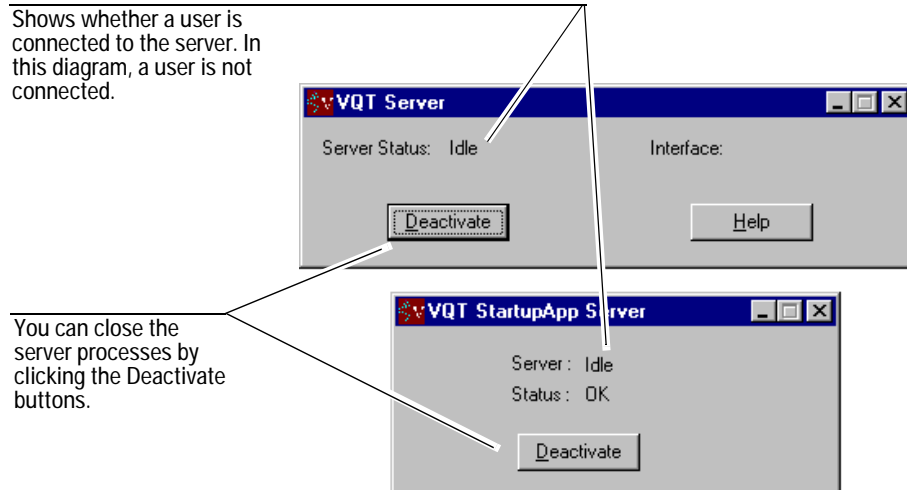

When you first start the VQT server process, these two dialog boxes open one on top of the other.

To stop these processes, click the Deactivate button in each of the two small dialog boxes.

NOTE

If you start VQT client software on a VQT Portable Analyzer when the server process have been started via AutoRun, then the VQT Portable Analyzer will display an error and close. You cannot run the server and client processes on the VQT Portable Analyzer at the same time.

Automatically Starting the VQT Server Processes

Use the following instructions to ensure that the VQT Portable Analyzer's server processes will automatically start when the device is rebooted:

- 1 Click the Windows Start button, point to Settings, and select Control Panel. The Control Panel appears.
- 2 Double-click the Services icon. The Services dialog box appears:

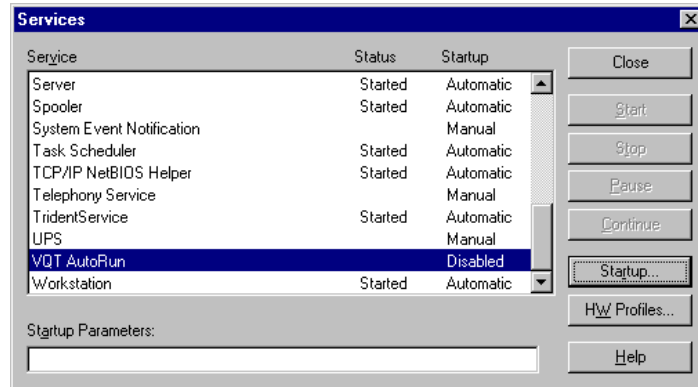

- 3 Scroll and select VQT AutoRun from the list.
- 4 With VQT AutoRun highlighted, click Startup. The Service dialog box appears.

2 Getting Started

5 Set the Log On As parameters as shown here:



6 Click OK.

7 In the Services dialog box, click Start to start the processes now, or click Close to cause the processes to start the next time the VQT Portable Analyzer is powered on.

Setting the Watchdog Timer

The purpose of the watchdog timer is to ensure that VQT servers that are not easily accessible or installed some distance from the user will periodically determine whether the VQT server processes are operational. If the watchdog determines that a single service is unavailable, it will wait before rebooting the VQT Portable Analyzer when someone is connected to or using the working interface.

NOTE

The watchdog timer is only run when the VQT server processes are run automatically. See "Automatically Starting the VQT Server Processes" on page 35 for more information.

To set the watchdog timer, you will turn on the watchdog timer on the VQT Portable Analyzer first and then set the options using a client machine.

Use the following instructions:

- 1 At the installed VQT Portable Analyzer, locate and open the Autorun.cfg file stored at the root of the hard drive. (You can open the file in any text editor.) It looks like this:

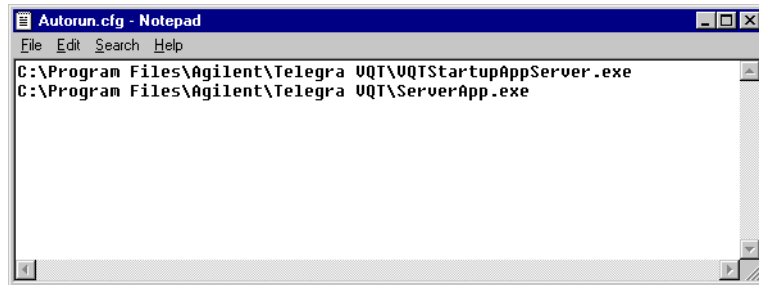
**NOTE**

Your Autorun.cfg file may look different from the one above depending on where you installed the software. The instructions in this section will work if you include the path where the VQTWatchDog.exe file is stored.

- 2 Edit the file to include a path to the VQTWatchDog.exe file, similar to this:

```
C:\Program Files\Agilent\Telegra VQT\VQTWatchDog.exe
```

- 3 Save and then close the Autorun.cfg file.
- 4 Reboot the VQT Portable Analyzer. After the reboot, the VQT server services and the watchdog timer will be running automatically. In addition to the services windows, you will see a window similar to this:

2 Getting Started

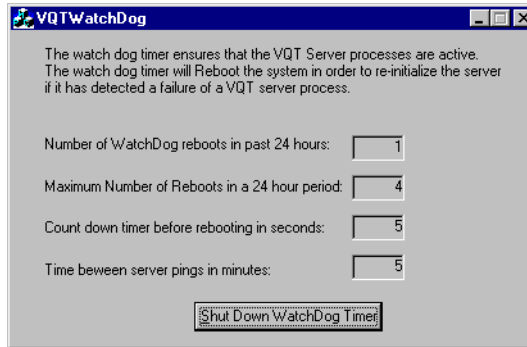

- 5 Go to the connected client machine and start the VQT software.
- 6 At the Server Setup tool, click Server List Admin. The Server List dialog box appears.

- 7 Select the VQT Portable Analyzer in the list and click Maintenance. The Server Maintenance dialog box appears:

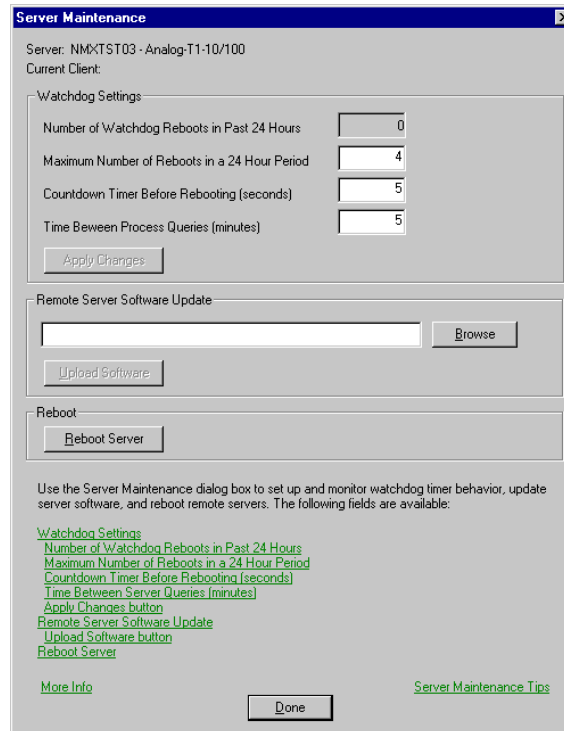

- The first field, Number of Watchdog Reboots in Past 24 Hours, is a read-only field. It shows many times the VQT device has rebooted in the last 24 hours. If the device has rebooted five times and the maximum number of reboots is set to five, you should check the VQT device and determine the problem.
- By default, the watchdog timer will reboot a maximum of four times in a 24-hour period. You can change the maximum number of reboots by typing a new number in this field.

2 Getting Started

- By default, the watchdog timer will wait five seconds before rebooting. You can change the time that it waits by typing a new number in this field. (This option is primarily important if you are at the VQT Portable Analyzer and want to save files before the reboot.)
 - By default, the watchdog timer will check the VQT server processes every five minutes. You can change the time that elapses between checks by typing a new number in this field.
- 8 When you are finished, click Done and close the Server List dialog box.

See the Help for more information.

Setting Up a Controlling PC

The VQT Portable Analyzer can act as a controlling PC in a VQT test system and be used to remotely control VQT Network Servers, VQT Responders, other VQT Portable Analyzers, or Advisors. When controlling a VQT server from a PC, all interaction with the server is through the PC's client user interface. Two controlling PCs cannot control a single server at the same time; however, a single, controlling PC can have up to four client windows open and running simultaneously.

To enable remote operation, you must order and enable the Agilent VQT Client Software License (product number J1979A). With the product, you will receive a client license key.

These instructions assume that the controlling PC and VQT Portable Analyzer devices are interchangeable. Where differences in the setup procedure exist, those are noted. To set up a controlling PC (or a VQT Portable Analyzer as a controlling PC), you must:

- Install the VQT software
- Enter your client license key
- Verify that the PC (or VQT Portable Analyzer) is installed on the IP management network

Each of these steps is described on the following pages. First, it is important to ensure that the controlling PC you've chosen meets the following requirements.

Requirements for a Controlling PC

The following are the minimum requirements for a controlling PC:

- Operating System: Windows 98 SE, Windows NT 4.0 SP5, Windows 2000
- CPU: Pentium III, 200 MHz
- Memory: 64 Mbytes
- Hard Disk Drive: 200 Mbytes available
- Screen Resolution: 800x600
- Microsoft TCP/IP stack
- Microsoft Internet Explorer 4.0 (or higher)

The following are the recommended requirements for a controlling PC:

- Operating System: Windows 98 SE, Windows NT 4.0 SP5, Windows 2000
- CPU: Pentium III, 500 MHz
- Memory: 128 Mbytes
- Hard Disk Drive: 200 Mbytes available
- Screen Resolution: 1024x768
- Microsoft TCP/IP stack
- Microsoft Internet Explorer 4.0 (or higher)

Installing the VQT Software on the Controlling PC

Follow these steps to install the VQT software on a controlling PC (or on the VQT Portable Analyzer running as a controlling PC):

- 1 Place the latest VQT installation CD into the PC's CD-ROM drive.

2 Getting Started

- 2 Click the Windows Start button and select Run. The Run dialog box appears.
- 3 Type `d:\setup.exe` in the field and click OK. (Replace “d” with the drive letter assigned to the CD-ROM drive on the VQT Portable Analyzer, if different.)

When prompted to select the components to install, set the options as shown here:

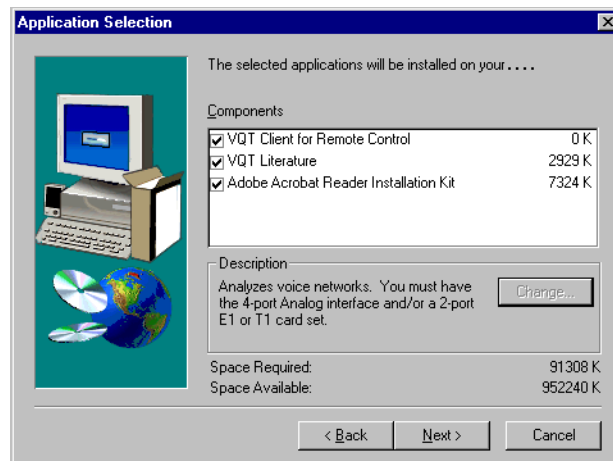

- Select the VQT Server option when you want this device to be controlled by another VQT server or controlling desktop or laptop PC. Do not select this option on a controlling PC.
- Select the VQT Client for Remote Control option if you plan to use this device to control other VQT servers within the test system. This option requires a client license key, which you will have to type later when you run the software. Do not select this option on a device to be controlled.
- Select VQT Literature to install the documentation.
- Select Adobe Acrobat Reader Installation Kit to ensure you can view the VQT documentation.

Entering the Client License Key

When the installation is finished, start the VQT software, and enter your client license key. It is required to enable remote operation. The client license key can be found in your VQT literature pack. If you did not receive it, contact your Agilent Sales Representative.

NOTE

If you intend to install the VQT software on multiple client devices, you will need separate licenses.

- 1 Click File and select Client License Key. The Client License Key dialog box appears.
- 2 Type your client license key in the field and click OK.

Configuring the PC for IP Network Connectivity

Contact your Network Administrator to make sure your PC is connected to the IP management network and running a TCP/IP protocol stack. It is beyond the scope of this document to provide comprehensive instructions on how to enable and connect your desktop or laptop PC for IP network connectivity. Contact your Network Administrator if your PC is not already networked.

2 Getting Started

Connecting to the Network Under Test

Connecting the VQT to the device, system, or network to be tested is also relatively simple once you remember the VQT's basic test assumption: Voice quality is tested end-to-end from the perspective of the human talker and listener. In most cases, VQT servers replace telephone equipment at each end of the connection so that you can place a call or calls from a VQT port or channel through a telephony network (such as VoIP or PSTN) to another VQT port or channel.

This section discusses the following connection information:

- “FXO and E&M Connections” on page 45
- “Ground Connections” on page 49
- “T1 and E1 Connections” on page 53
- “10/100 Ethernet Connections” on page 57

All of the VQT Portable Analyzer connections are made on the left-side panel or on the optional PCMCIA NIC installed in the front.

FXO and E&M Connections

The following diagram illustrates how the VQT plays the role of two telephones in an end-to-end test environment for an analog (FXO/E&M) connection. For the VQT to measure voice quality, it must control one or both ends of a voice circuit (depending on the type of measurement that is run) and be able to actively transmit specific test signals onto that circuit.

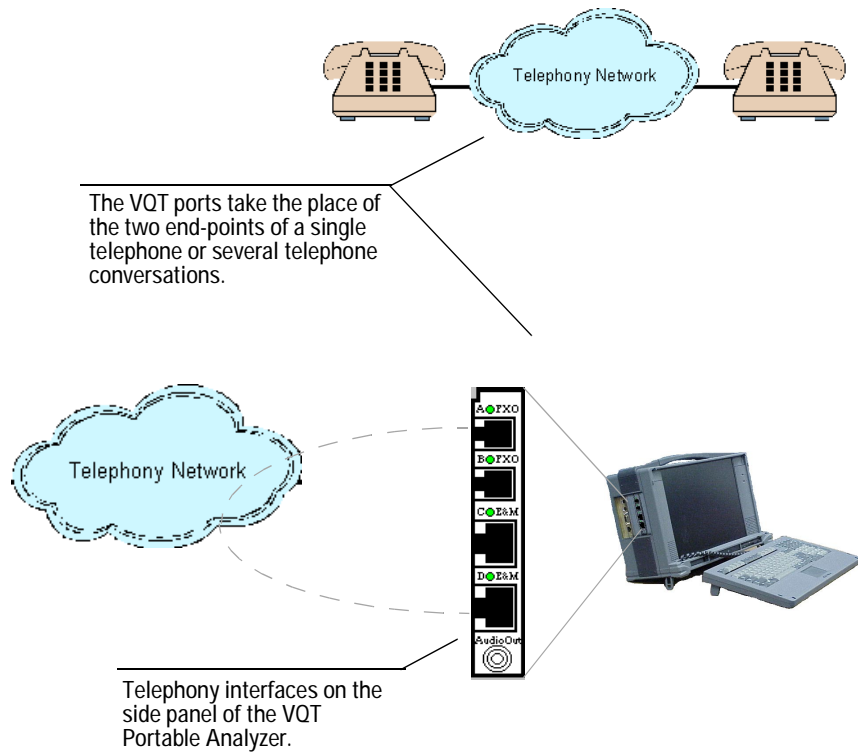

NOTE

This equipment must not be connected to the telephone network unless it is connected through protective circuitry that is registered pursuant to Part 68 of the Federal Communications Commission rules.

2 Getting Started

FXO Connection Diagram

The following diagram shows an end-to-end connection between FXO ports A / B of the VQT Network Server and telephony or network device(s) that support the FXS interface. You need to use one custom Agilent Technologies RJ-11 cable (part number 5065-1140) to ensure that the VQT communicates properly with the telephone network. The custom Agilent Technologies RJ-11 cables include the following features:

- 6-pin slots / 4 conductors
- Twisted cable for noise reduction

You can use an additional off-the-shelf RJ-11 cable and coupler to extend the cable length for loop start operation; however, because of the way off-the-shelf cables can be wired, you must use one and only one Agilent custom RJ-11 cable for each port connection to ensure ground start operation. See the Help for FXO wiring and pinouts and for more information about FXO connections in general.

NOTE

For FXO and E&M interfaces, the electrical state of the VQT ports affect telephony network operation. Therefore, it is a good idea to know the electrical and protocol characteristics of the network to which you are connecting. Later, when you start the VQT software, you can make sure the Port Setup parameters match these characteristics.

The VQT Portable Analyzer provides for end-to-end testing regardless of the port used. In other words, you can place calls from an FXO port to an E&M port if the situation requires it.

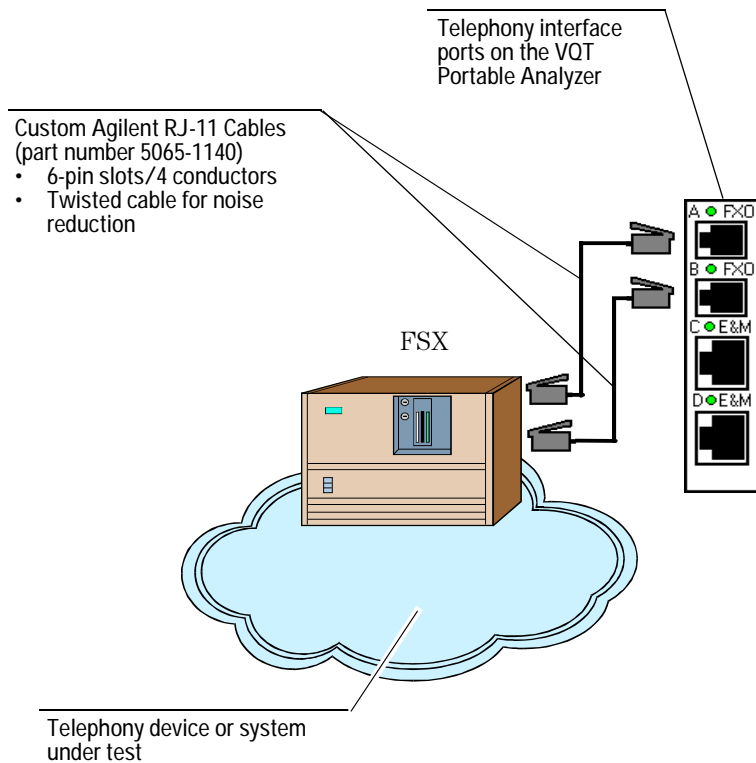

E&M Connection Diagram

E&M connections can be as simple as plugging the RJ-45 connector into the E&M port on the device or system under test, or as complex as connecting individual wires to punch-down blocks. The Agilent Technologies custom RJ-45 cables (part number 5065-0452) with the following features are recommended:

- 8-pin slots/8 conductors

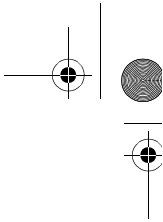
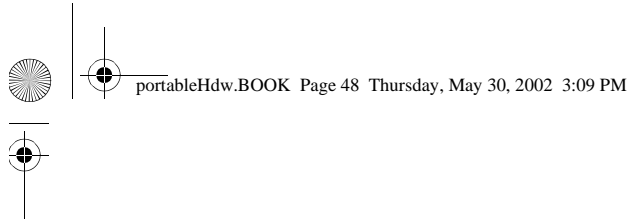

2 Getting Started

- Twisted cable for noise reduction

The following diagram shows a common end-to-end E&M connection. The E&M connection port is designed to support distinct sides of the network connection. See the Help for descriptions of pinouts and wiring for Agilent's E&M cables and connectors.

NOTE

For FXO and E&M interfaces, the electrical state of the VQT ports affect telephony network operation. Therefore, it is a good idea to know the electrical and protocol characteristics of the network to which you are connecting. Later, when you start the VQT software, you can make sure the Port Setup parameters match these characteristics.

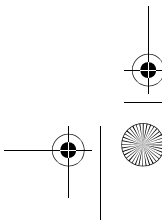
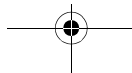
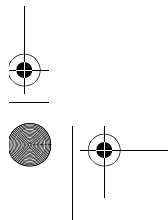
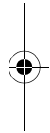

The following diagram shows a common end-to-end E&M connection.

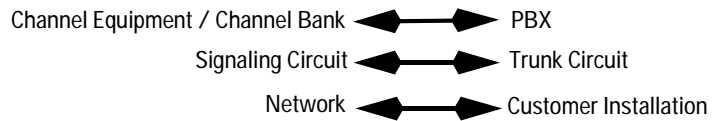
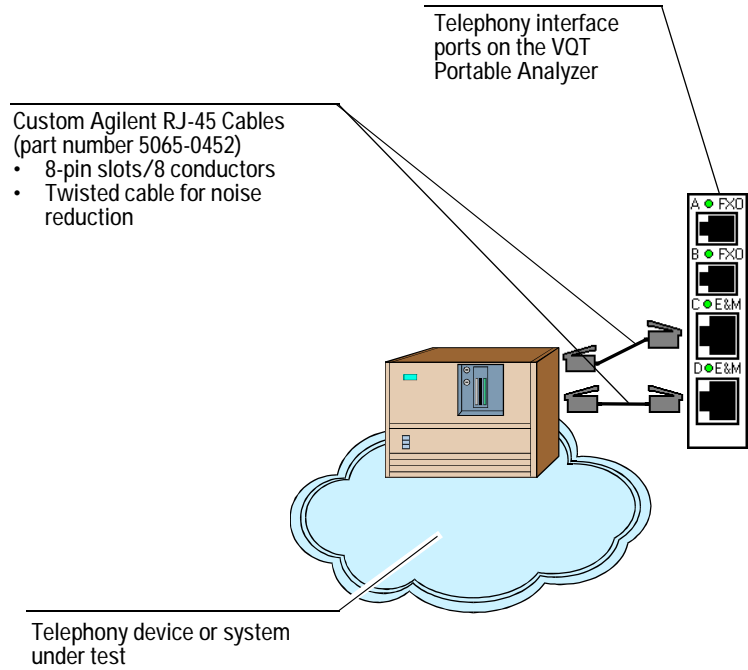

Ground Connections

The VQT Portable Analyzer is equipped with several electrical grounding options that increase the reliability of its operation with analog connections and ensure compliance with domestic and international telecommunication and safety standards. (The ground cable part number is J3953-61604.)

2 Getting Started

Refer to the procedures on the following pages to use these grounding options via the switch and terminal block faceplate on the side of the VQT Portable Analyzer:

Switch 1	Switch 2	Function
UP	UP	Earth ground: The VQT Portable Analyzer is Telecommunications Network Voltage (TNV) grounded using the terminal block connector. Attach one end of the ground cable (part number J3953-61604) to the terminal block and the other end to a reliable earth ground.
UP	DOWN	Chassis ground: The VQT Portable Analyzer is TNV grounded using the ground wire in the power cable (no extra cable connection is necessary).
DOWN	UP	TNV ground (internally isolated)
DOWN	DOWN	TNV ground (internally isolated)

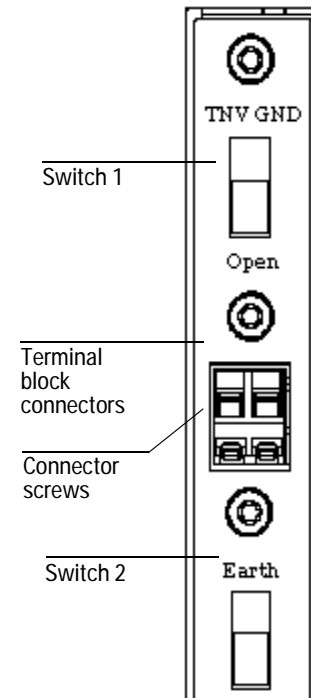

NOTE

Port Setup configuration and ground configurations are related. See the Help for more information. Grounding is required only in analog test situations.

To ground the VQT Portable Analyzer to true earth ground, follow these steps:

- 1 Ensure the VQT Portable Analyzer is powered off.

- 2 Attach the supplied cable (part number J3953-61604) to one of the terminal block connectors. See the preceding diagram.
- 3 Tighten the connector screw to hold it in place.
- 4 Connect the other end of the cable to earth ground, which is typically provided by a metallic rod or pipe driven into the earth.
- 5 Set the switches as shown in the table in the preceding table.

It is possible for the equipment to be functional under a specific configuration, but not conform to safety standards:

- To ground the VQT Portable Analyzer using the ground wire in the power cable (also referred to as chassis ground), set the switches as shown in the table in the preceding diagram. The VQT is shipped with this configuration as the default connection because, in most cases, the chassis ground provides adequate grounding and reliable operation.
- In some situations, such as Scandinavian countries that use IT power systems or if equipment is a large distance from the grounding source, the earth ground setting is required.
- The TNV ground, which is internally isolated, should be used for FXO loop start operations.

2 Getting Started

Refer to the following table to determine the correct switch settings for your test situation.

	Switch Modes:					
	FXO Loop Start Only	FXO Ground Start Only	E&M Only	FXO Loop Start/FXO	FXO Loop Start/E&M	FXO Ground Start/E&M
Chassis Ground	Functional: Yes Safety: No	Functional: Depends on ground quality Safety: Not all countries	Functional: Depends on ground quality Safety: Not all countries	Functional: Depends on ground quality Safety: Not all countries	Functional: Depends on ground quality Safety: Not all countries	Functional: Depends on ground quality Safety: Not all countries
Earth Ground	Functional: Yes Safety: No	Functional: Yes Safety: Yes	Functional: Yes Safety: Yes	Functional: Yes Safety: Yes	Functional: Yes Safety: Yes	Functional: Yes Safety: Yes
TNV Ground (internally isolated)	Functional: Yes Safety: Yes	Functional: No	Functional: No	Functional: No	Functional: No	Functional: No

NOTE

The chassis ground switch mode may be too noisy, and a differential voltage from earth ground may interfere with the test signal. To fix this condition, run a wire to earth ground.

T1 and E1 Connections

The VQT Portable Analyzer T1 and E1 acquisition hardware consists of two components: the T1/E1 Interface card and the Digital Analysis card. The T1/E1 Interface card provides the connection to the T1 or E1 network and the signaling capability for setting up, tearing down, and maintaining calls. The Digital Analysis card works in concert with the T1/E1 Interface card and enables the current set of VQT measurements. The acquisition hardware provides easy access to the most common interfaces on voice gateways – T1 and E1 interfaces.

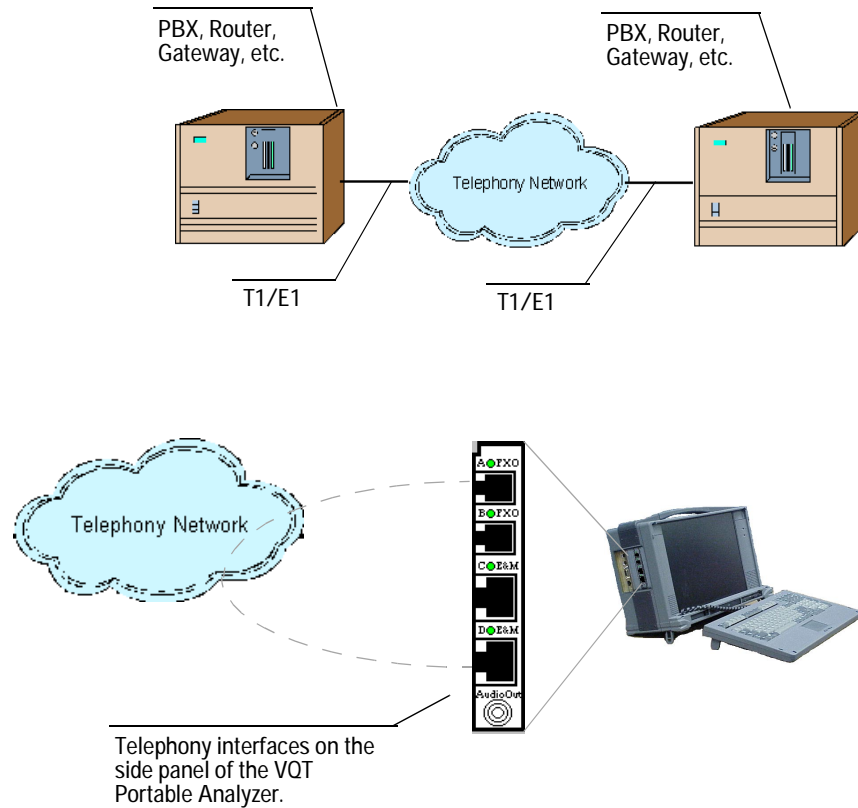

2 Getting Started

For the T1 and E1 environments, the VQT Portable Analyzer ports replace the trunks at both ends of the connection so that you can place a call or calls from a port or channel through a telephony network (VoIP, PSTN, etc.) to another port or channel. The VQT Portable Analyzer enables you to place calls from channel-to-channel on the same port or from port-to-port. While this diagram shows telephony end points being replaced by ports on a single VQT server, these end points could also be individual VQT Portable Analyzers.

Refer to the Help for detailed connection diagrams, cable types and pinouts, and adapter information.

NOTE

For T1 and E1 interfaces, the electrical state of the VQT ports affect telephony network operation. Therefore, it is a good idea to know the electrical and protocol characteristics of the network to which you are connecting. Later, when you start the VQT software, you can make sure the Port Setup parameters match these characteristics.

T1 Connection Diagram

You use T1 connections when you want the VQT Portable Analyzer to emulate the end trunks at both ends of the digital T1 connection. T1 links are conventional in North America. Note that your VQT has either a T1 link or an E1 link, but not both. The following diagram shows an end-to-end connection between two T1 ports, Port 1 and 2 of the VQT and the telephony network device(s).

See the Help for descriptions of pinouts, of wiring for RJ-48C connectors, and of LED Status Indicators.

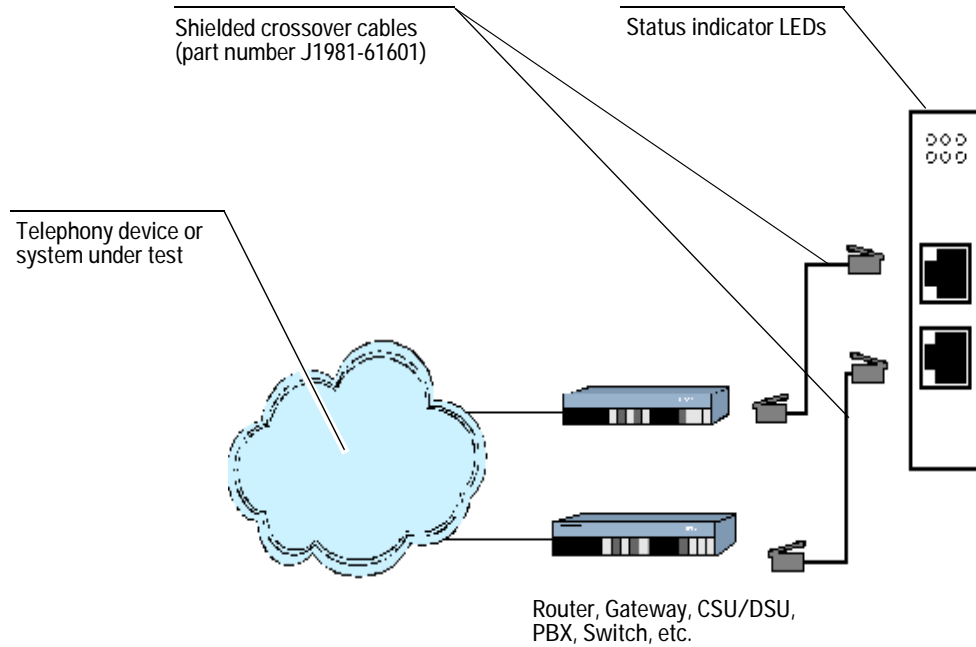

NOTE

The cables provided are crossover cables (part number J1981-61601) and have been tested for compatibility with common telephony equipment. Check if your equipment needs a different type of cable. Refer to your equipment specifications and the pinout descriptions in the Help to determine the appropriate cables for your needs. Failure to use a shielded cable may negate your Class B approval.

E1 Connection Diagram

You use E1 connections when you want the VQT to emulate the end trunks at both ends of a digital E1 connection. E1 links are conventional in Europe and most of the countries outside of North America. Your VQT has either a T1 link or an E1 link, but not both. For connectivity to 120 ohm E1 trunk, use a shielded

2 Getting Started

crossover cable (part number J1981-61601). For connectivity to a 75 ohm E1 trunk, use a 120 ohm to 75 ohm converter and a straight-through cable (part number J1981-61602). The converter can be purchased from most cable and connector manufacturers.

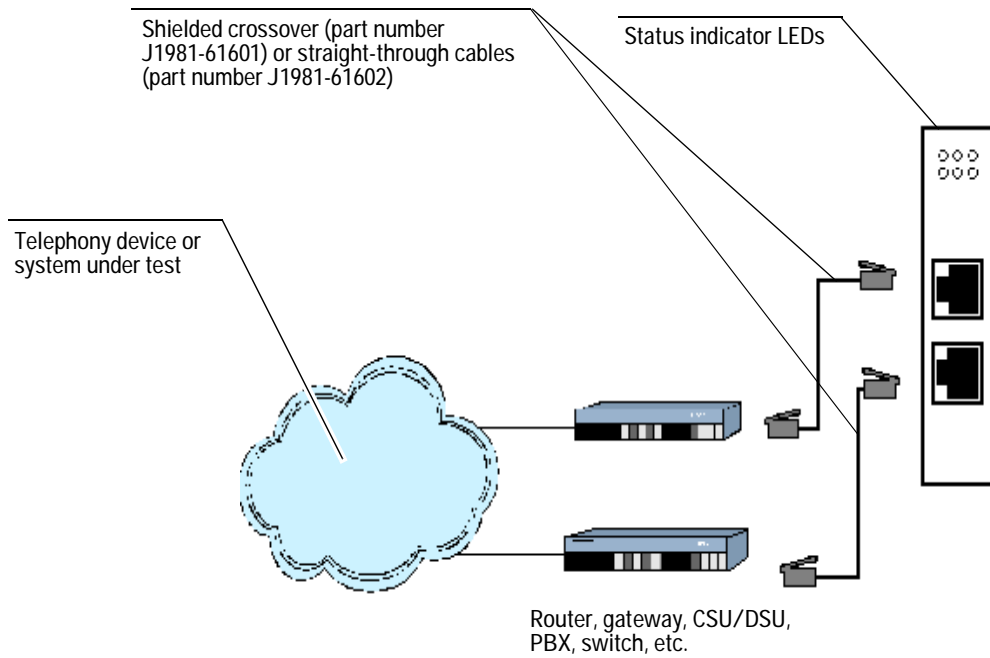

NOTE

Refer to your equipment specifications and the pinout descriptions in the Help to determine the appropriate cables for your needs. Failure to use a shielded cable may negate your Class B approval.

10/100 Ethernet Connections

The VQT Portable Analyzer 10/100 Ethernet acquisition hardware is a built-in network interface card (NIC) and an optional, user-installed PCMCIA NIC (J5480A). See Appendix B for instructions to install the PCMCIA.

You can use a VQT Portable Analyzer with two NICs in the following ways: One port can be used for remote or distributed control and the second port can be used for VQT testing. You can also use a single port for control and VQT testing, leaving the other port unused. In the case where one port is used for control and the other for VQT testing, you can use either port for either purpose. Appendix B contains information about installing and configuring the second NIC. Either NIC can provide a connection to the 10/100 Ethernet network and the signaling capability for setting up, tearing down, and maintaining calls.

If your VQT Portable Analyzer has two NICs, you can use either, but not both at the same time, for the control network connection. If you plan to operate the VQT Portable Analyzer in a remote or distributed environment, connect a VQT Portable Analyzer NIC to an IP network LAN drop, hub, router, or switch using a 10/100 RJ-45 Ethernet cable (part number 5065-0452).

NOTE

You may want to contact your Network Administrator prior to making this connection to ensure that you have the appropriate permissions and that the proper LAN connections are enabled.

The VQT 10/100 testing provides call-only or answer-only testing on the same VQT server. In addition, the VQT 10/100 testing can only place or answer a single call at a time.

For the Ethernet test environment, the VQT Portable Analyzer can replace the digital telephone (or other VoIP device) at the end of a call terminating in an IP or VoIP network. The other end of the call can be another VQT server or other telephony device. To fully use the 10/100 Ethernet interfaces, you must purchase and enable the Ethernet VoIP Interface license

2 Getting Started

(J5479A). You will be prompted for the license after starting the software and selecting the 10/100 acquisition hardware in the Server Setup tool.

The following diagram shows how the VQT Portable Analyzer plays the role of one end-point in a single, end-to-end, 10/100 Ethernet (VoIP) telephone call with another VQT server or other telephony device. A single 10/100 port is used for both control and voice quality testing.

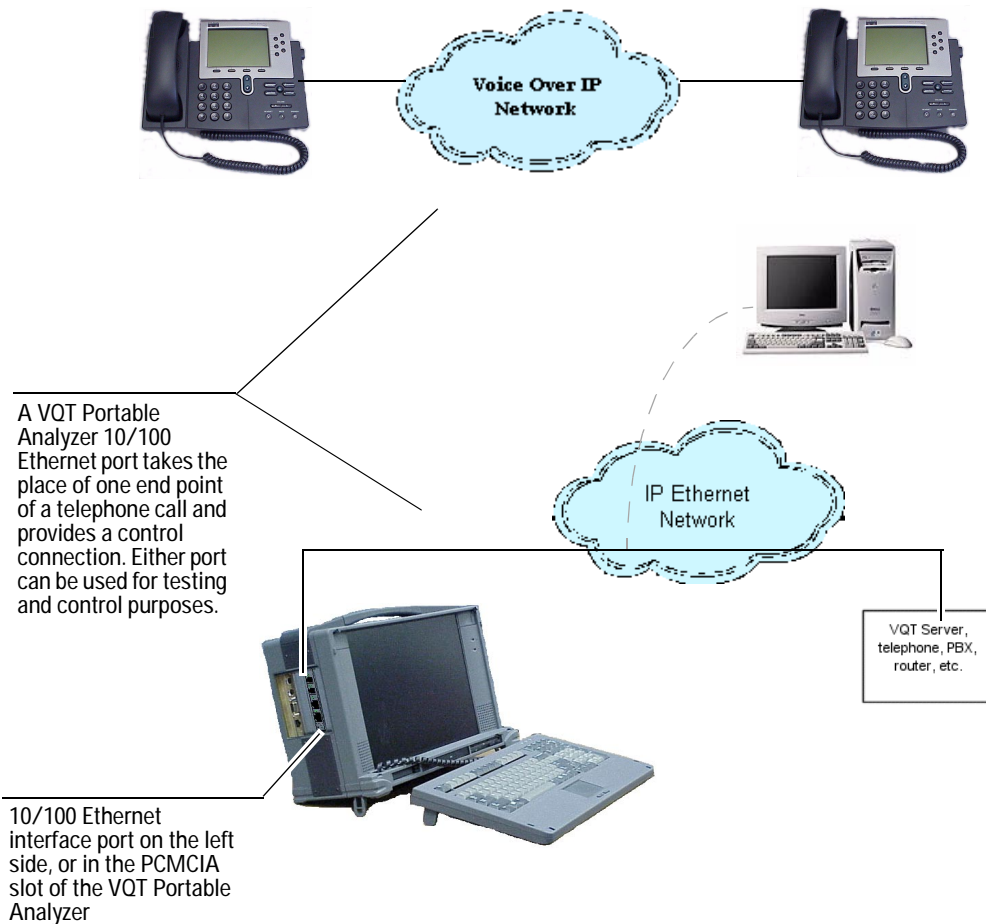

Refer to the Help for detailed connection diagrams, cable types and pinouts, and adapter information.

10/100 Ethernet Connection Diagram

Use 10/100 Ethernet (VoIP) connections when you want the VQT to emulate the digital telephone or VoIP connection points at both ends of the VoIP network. The following diagram shows an end-to-end connection between two VQT Portable Analyzer 10/100 Ethernet ports over a VoIP network.

The following are used in this configuration:

- Cables: RJ-45, 10/100base-T Ethernet (part number 5065-0452)
- Protocol: Standard Windows TCP/IP protocol stack
- Testing Protocol: SIP and/or H.323 protocols

One or both of the connections could come from the PCMCIA NIC.

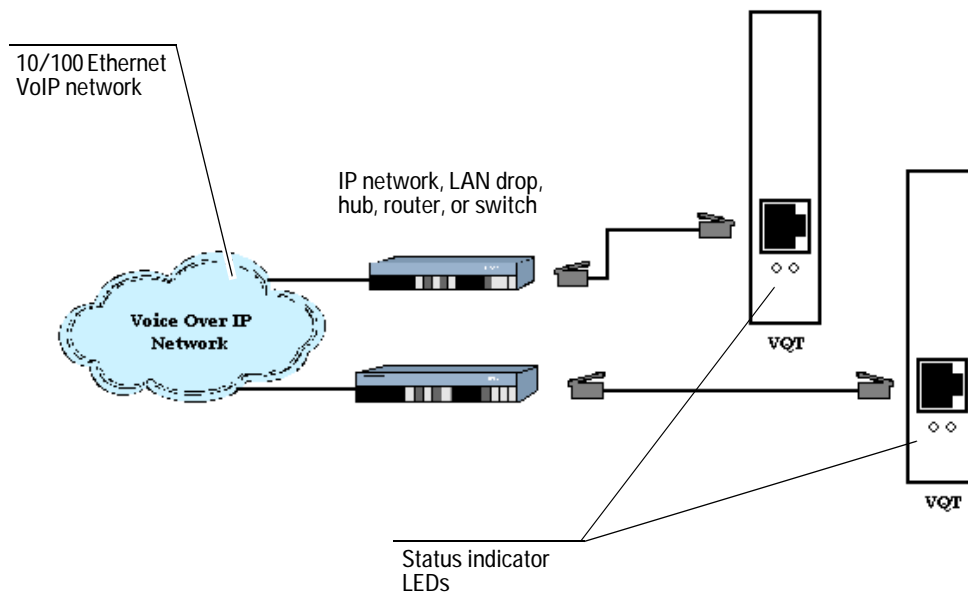

See the Help for descriptions of pinouts, wiring for RJ-45 connectors, and LED Status Indicators.

2 Getting Started

Starting the VQT Software and Using the Server Setup Tool

After you have set up and configured the VQT Portable Analyzer (and the controlling PC if you are planning to remotely control the VQT Portable Analyzer), you are ready to run VQT measurements by using the VQT software.

Start the VQT software on the VQT Portable Analyzer or controlling PC



Double-click the VQT icon to start the application. You can also use the Windows Start menu to start the VQT.



The VQT Welcome screen appears. You can use this window to get more information about using the VQT software or to get information about voice quality testing in general.

Once you view the information, click the Close button to proceed.

Add or select VQT servers for testing using the Server Setup tool

Use the Server Setup tool to perform all initial tasks related to local or remote single-server and multiple-server voice quality testing.

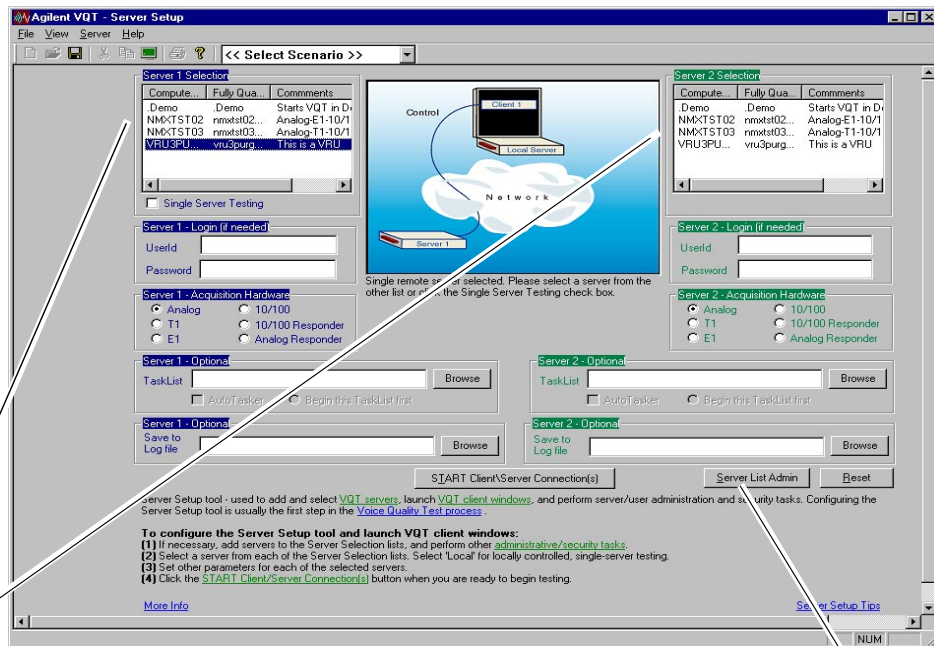

If you plan to perform locally controlled, single-server testing, click Local in the Server Lists, select the acquisition hardware, click the Start Client/Server Connections button, and begin testing.

If you plan to perform remote or distributed testing, you need to add servers to the server list located at the top of the Server Setup tool. To add servers, click the Server List Admin button. The Server List dialog box appears as shown on the next page.

NOTE

To remotely control any VQT device, you need to enter your client license key. To do so, use the File menu.

2 Getting Started

For remote or distributed testing, build the server list

In the Server List dialog box, you can build a list of servers (including the VQT Portable Analyzer if you plan to remotely control it), and control the server security and configuration.

You can build a list of servers from which to select in the Server Setup tool.

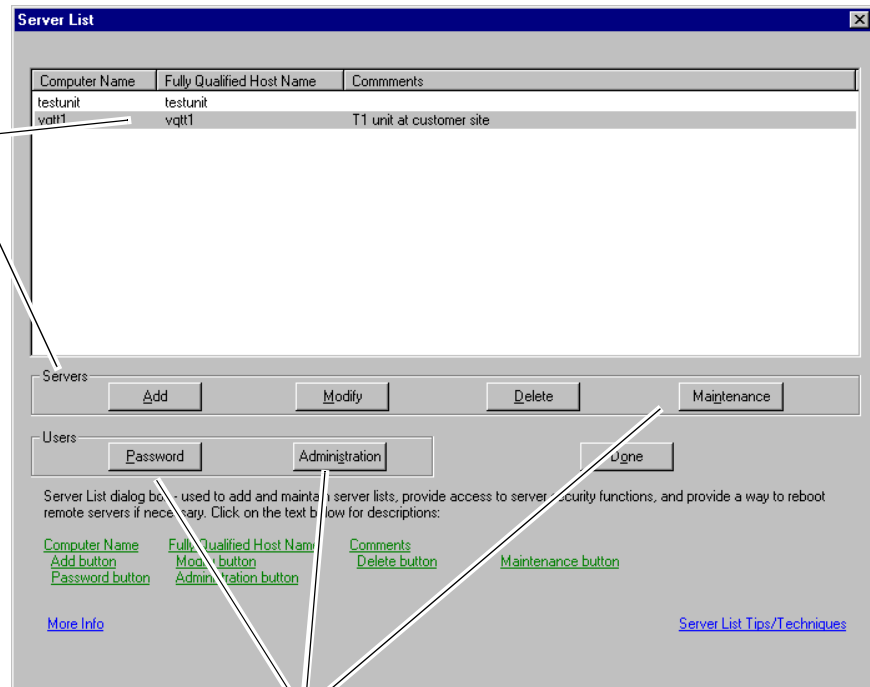

You can access the tools necessary to set up and maintain server security and other important remote control configuration settings.

Select the servers and acquisition hardware to get started

After you close the Server List dialog box, you can select the VQT Portable Analyzer (locally or remotely) or other added servers and begin voice quality testing.

Select the newly added server(s) in the Server Lists.

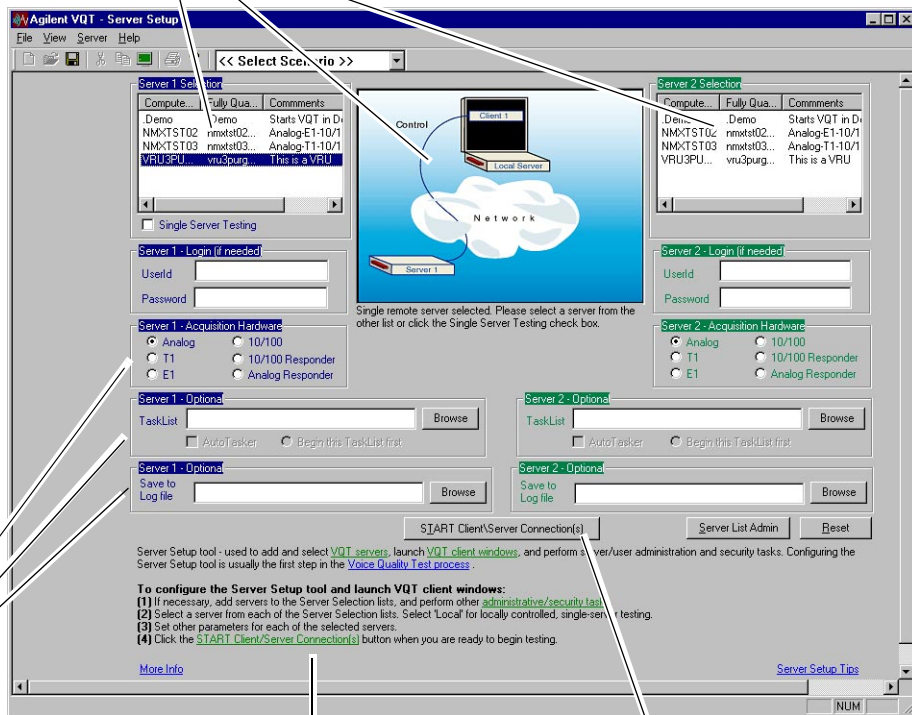

Select the acquisition hardware to be used on the selected servers. You can also select the TaskLists and log files to use after client windows are opened.

Multi-mode embedded Help leads you through the setup.

Click the Start Client/Server Connection button to open client windows and begin testing.

The first time you configure the Server Setup tool and open client windows, you will be prompted for your PESQ, PAMS, and/or PSQM software license keys that are provided in the VQT literature. Although you will be prompted for this information

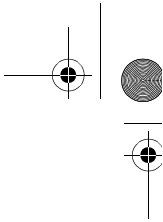
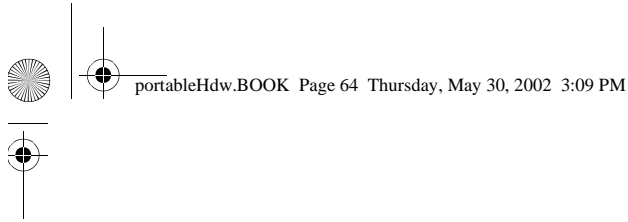

2 Getting Started

only once, you will have to enter it for each VQT server on which Clarity (PESQ), Clarity (PAMS), and/or Clarity (PSQM) is to be run. Click the Enable Features option in the File menu to type your software license keys.

This Setup Guide focused on setup, configuration, and network connection for the VQT Portable Analyzer. Refer to the *Agilent VQT Getting Started Guide* or to the Help for more information on using the VQT software.

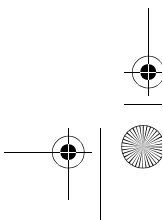
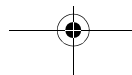
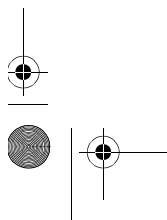

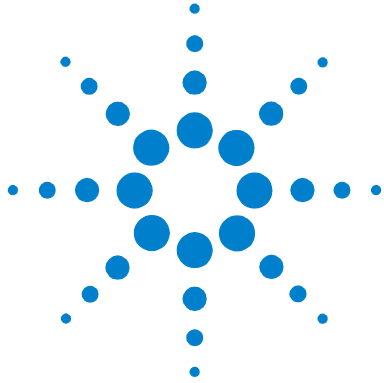

A Specifications and Operating Conditions

FXO and E&M Card Specifications	66
T1 and E1 Card Specifications	67
10/100 Ethernet NIC Specifications	69
Operating Conditions	72



A Specifications and Operating Conditions

FXO and E&M Card Specifications

FXO Ports

Guaranteed accuracy of transmission or reception of a sine wave is plus or minus 1 dBm across the following conditions:

300 Hz to 3200 Hz

-3 dBm to -50 dBm

USA 600 ohms impedance, USA 900 ohms impedance.

Typical accuracy is plus or minus 0.3 dBm from 500 Hz to 3000 Hz.

E&M Ports

Guaranteed accuracy of transmission or reception of a sine wave is plus or minus 1 dBm across the following conditions:

300 Hz to 3200 Hz

-3 dBm to -45 dBm

Standard 600 ohms impedance, Standard 900 ohms impedance.

Typical accuracy is plus or minus 0.3 dBm from 500 Hz to 3000 Hz.

FCC Part 68
Disclaimer

This equipment must not be connected to the telephone network unless it is connected through protective circuitry that is registered pursuant to Part 68 of the Federal Communications Commission rules.

T1 and E1 Card Specifications

T1 Ports

DSX-1 Interface

Interface: Complete interface for two T1 trunks (ANSI T1.102, T1.403)

Framing: D4, ESF

Line code: AMI, B8ZS

Zero bit: Suppression selectable B8ZS, jammed bit (ZCS) or no zero code suppression

Alarm signal capabilities: Yellow, Red, and Blue

Counts: Bipolar violation, F(t) error, and CRC error

Robbed bit: Selectable on a per-trunk basis

Loopback: Per-channel and overall

Support of ISDN and CAS signalling

Connector: Two 100 ohm RJ48C connectors

E1 Ports

CEPT E1 G/703 Telephony Interface

Interface: G.703 2048 kbps trunk interface

Line code: HDB3 or AMI (no zero code suppression)

Zero bits: Selectable B8ZS, jammed bit (ZCS) or no zero code suppression

Alarm signal capabilities: Yellow, Red, and Blue

Counts: Bit error rate, CRC errors, slips, line code violations, far-end block errors

Loopback: Per-channel and overall

A Specifications and Operating Conditions

Connector: Up to two 75 ohm RJ-48C with BNC adapter cables
or up to two 120 ohm RJ-48 connectors

Supporting of ISDN and CAS trunks signalling

10/100 Ethernet NIC Specifications

PCI 10/100 Ethernet Port (built-in)

Network Interface

10 Mbps Ethernet 10BASE-T	Ethernet IEEE 802.3 industry standard for a 10 Mbps baseband CSMA/CD local area network
100 Mbps Ethernet 100BASE-TX	Ethernet IEEE 802.3u industry standard for a 100 Mbps baseband CSMA/CD local area network

Cable Requirements and Maximum Cable Lengths for RJ-45 Port

Network Environment	Cable Required	Maximum Cable Length
10 Mbps (10BASE-T)	Category 3, 4, or 5 unshielded twisted-pair	100 m (328 ft)
100 Mbps (100BASE-TX)	Category 5 unshielded twisted-pair	100 m (328 ft)

A Specifications and Operating Conditions

Interpreting the LEDs for an RJ-45 Connector

LED	State	Meaning
10 LNK (link)	On	If drivers are installed, the 10BASE-T connection is active. If drivers are not installed, the NIC is receiving power.
	Off	Something is preventing the connection between the NIC and the hub or switch.
	Blinking	The cable polarity is reversed. Try a different network cable or contact you system administrator.
100 LNK (link)	On	If drivers are installed, the 100BASE-TX or 100BASE-FX connection is active. If drivers are not installed, the NIC is receiving power.
	Off	Something is preventing the connection between the NIC and the hub or switch.
	Blinking	The cable polarity is reversed. Try a different network cable or contact you system administrator.
ACT (activity)	Blinking	Network Traffic is present.
	Steady	Heavy network Traffic is present.
	Off	No network Traffic is present.

PCMCIA 10/100 Ethernet Port (Optional J5480A)

Network support includes:

Novel Netware, Microsoft Windows 2000, Windows 95, Windows 98, Windows NT, Windows 3.x, LAN Manager, Artisoft LANtastic, Banyan VINES, and Digital PATHWORKS. NDIS and ODI drivers, and Packet driver for TCP/IP.

Cable Requirements and Maximum Cable Lengths for RJ-45 Port

Network Environment	Cable Required	Maximum Cable Length
10 Mbps (10BASE-T)	Category 3, 4, or 5 unshielded twisted-pair	100 m (328 ft.)
100 Mbps (100BASE-TX)	Category 5 unshielded	100 m (328 ft.)

Interpreting the LEDs for an RJ-45 Connector

LED	State	Meaning
10 LNK (link)	On	If drivers are installed, the 10BASE-T connection is active. If drivers are not installed, the NIC is receiving power.
	Off	Something is preventing the connection between the NIC and the hub or switch.
	Blinking	The cable polarity is reversed. Try a different network cable or contact you system administrator.
100 LNK (link)	On	If drivers are installed, the 100BASE-TX or 100BASE-FX connection is active. If drivers are not installed, the NIC is receiving power.
	Off	Something is preventing the connection between the NIC and the hub or switch.
	Blinking	The cable polarity is reversed. Try a different network cable or contact you system administrator.
ACT (activity)	Blinking	Network Traffic is present.
	Steady	Heavy network Traffic is present.
	Off	No network Traffic is present.

A Specifications and Operating Conditions

Operating Conditions

Temperature	Operating	+5°C to +40°C (+41°F to +104°F)
	PCMCIA NIC Operating temp.	0°C to 65°C
	Non-Operating	-40°C to +70°C (-40°F to +158°F)
Humidity	Operating	5% to 93% relative humidity, non-condensing
	Non-Operating	5% to 93% relative humidity, non-condensing
Altitude	Operating	-305 to 4570 meters (-1000 to 15,000 feet)
	Non-Operating	-460 to 12,200 meters (-1500 to 40,000 feet)
Power Requirements	External	115/230 V~, 50-60 Hz, 4/2 A



B Installing and Configuring the NICs

Overview 74

Installation Instructions 75

The VQT Portable Analyzer is delivered with a single 10/100baseT Ethernet NIC installed in its chassis. This card is referred to as the internal NIC. You can order and install an additional PCMCIA 10/100 Ethernet interface (J5480A). See “Configuring the Internal NIC” on page 26 for configuration instructions.

With two NICs installed, you can use one for remote or distributed control of the VQT Portable Analyzer, and you can use the other for voice quality testing. Or, you can use one for both control and voice quality testing and ignore the second. In the case where one port is used for control and the other for voice quality testing, you can use either port for either purpose; in the case where you use one port for both control and voice quality testing, you can also use either NIC for this purpose.

NOTE

If you ordered the 10/100 Ethernet interface with a new VQT Portable Analyzer, the software is already installed for this new interface. In this case, go directly to “Configuring the Internal NIC” on page 26, and then to “Installing the Optional PCMCIA Card” on page 75.

Make sure you have obtained the 10/100 Ethernet VoIP license (J5479A). See “Optional PCMCIA 10/100 Ethernet Interface” on page 11 for more information.



B Installing and Configuring the NICs

Overview

The instructions in this appendix assume that you are configuring the PCMCIA NIC on a new VQT Portable Analyzer. The operating system is Windows NT 4.0, the software must be VQT 4.2 or later, and the supported PCMCIA card is a Xircom Cardbus 10/100 Ethernet card.

NOTE

If you have obtained a NIC other than the Xircom CardBus Ethernet 10/100 card, you must ensure that it is a 32-bit CardBus NIC and that it works with Windows NT. You will have to use the instructions provided with the card to install it. No further instructions will be provided for cards that are not the Xircom CardBus Ethernet 10/100 card.

The order in which you configure the internal and secondary NIC is critical because the first NIC installed becomes the primary NIC for the VQT Portable Analyzer. For this reason, it is important that you configure the internal NIC using the instructions in “Configuring the Internal NIC” on page 26 and then install and configure the optional PCMCIA NIC using the instructions in this appendix.

NOTE

The internal and PCMCIA installation instructions are identical for both the J1981A and the J1981B with the exception of the driver file choice. For a J1981B, select the Intel(R) PRO Adapter driver; for a J1981A, select the PCI Fast Ethernet Adapter driver.

Installation Instructions

The VQT Portable Analyzer is delivered with a single 10/100baseT Ethernet NIC installed in its cabinet. Using these instructions, you will install and configure a second 10/100 Ethernet NIC into a new VQT Portable Analyzer running the Windows NT 4.0 operating system. These instructions assume you have already configured the internal NIC (see “Configuring the Internal NIC” on page 26).

NOTE

Contact your Network Administrator for specific information, such as IP addresses, subnet masks, and default gateways, for this configuration process.

Installing the Optional PCMCIA Card

These instructions also assume you are installing a Xircom 10/100 Ethernet NIC and that you have already installed the VQT 4.2 software using the instructions in “Upgrading the VQT Software” on page 29.

WARNING

Do not use the installation CD delivered with the Xircom 10/100 Ethernet NIC. The supported drivers are included with the VQT 4.2 software. Instructions to configure the card are provided later.

- 1 Ensure the VQT Portable Analyzer is turned off before you start.
- 2 Remove the PCMCIA NIC from its packing material.
- 3 Insert the Xircom CardBus Ethernet 10/100 card into the VQT Portable Analyzer dual PCMCIA slots.

B Installing and Configuring the NICs

4 Turn on the VQT Portable Analyzer.

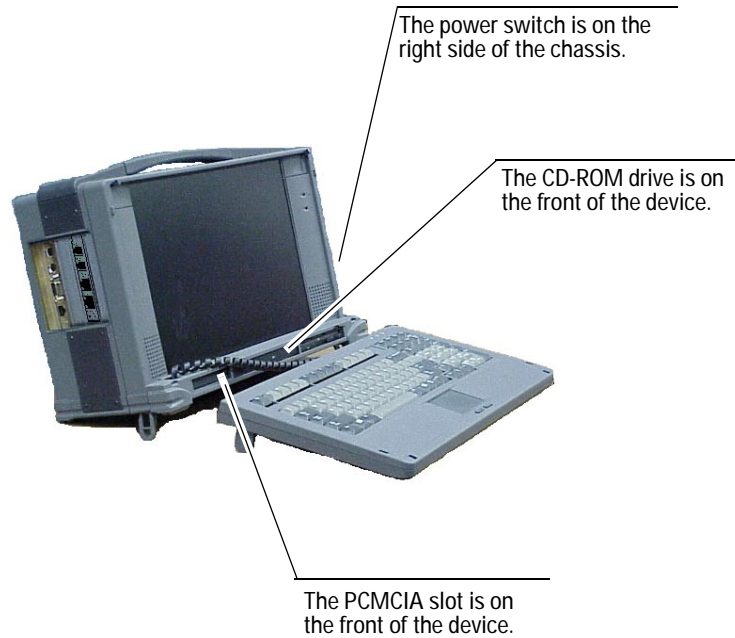

5 Follow the instructions as they display on the screen.

When you are finished, continue with the next section to configure the NIC.

Configuring the Second NIC

This section assumes that you have installed the Xircom CardBus Ethernet 10/100 Adapter into the slot on the front of the VQT Portable Analyzer.

Use the following instructions to configure the NIC:

- 1 Ensure that an active network cable is connected to the second NIC.
- 2 Right-click the Network Neighborhood icon on the Windows NT desktop and select Properties from the menu. The Network dialog box appears.
- 3 Select the Adapters tab and click the Add button on that tab. The Select Network Adapter dialog box appears.

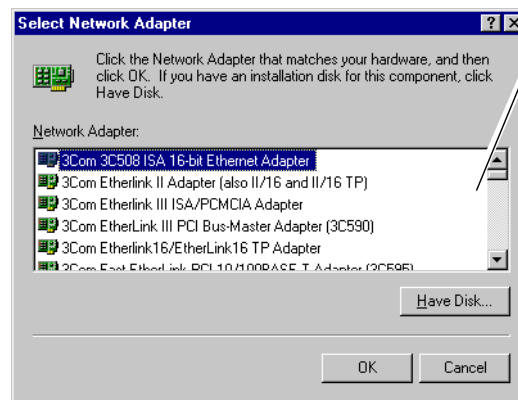

Scroll the list to select the NIC you installed.

- 4 Scroll in the list of NICs to locate the Xircom CardBus Ethernet 10/100 adapter.
- 5 Double-click the card and the Windows NT Setup dialog box appears.
- 6 Type `c:\i386` in the field and click Continue. The Xircom CardBus Ethernet 10/100 Setting dialog box appears.
- 7 Accept the default settings and click OK. The Network dialog box appears again listing both the internal and the second NIC.

B Installing and Configuring the NICs

- 8 Click Close. The Microsoft TCP/IP Properties dialog box appears.
- 9 Select the Xircom CardBus Ethernet 10/100.

NOTE

Ensure that you are using the information provided by your Network Administrator for these steps. Your Network Administrator's information may prompt changes to some of these instructions. These changes cannot be accounted for in this document.

- 10 Select the Obtain an IP address from a DHCP server option and a message appears asking if you want to enable DHCP.
- 11 Click Yes and the Microsoft TCP/IP Properties dialog box appears again.
- 12 Click Apply and then click OK.
- 13 You will be prompted to restart your computer. Click Yes to restart.

Using these instructions, the internal NIC (configured in "Configuring the Internal NIC" on page 26) remains the primary NIC and can be used for network access. The secondary NIC can only be used for measurements and control within the VQT system. To use the PCMCIA NIC for network access, the internal NIC must be uninstalled and the PCMCIA NIC must be made the primary NIC for this computer.

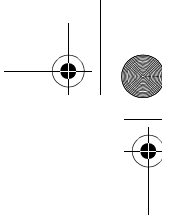

C Regulatory Information

Regulatory Compliances 80
Declaration of Conformity 81

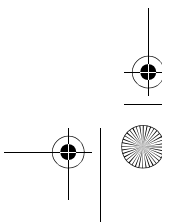
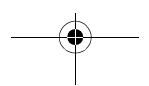
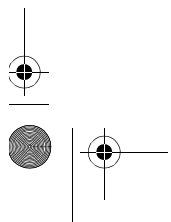

C Regulatory Information

Regulatory Compliances



This product conforms to the following regulatory requirements:

Electromagnetic Compatibility	IEC 61326-1 European Low-Voltage and EMC Directives AS/NZS 2064.1 ICES/NMB-001
Safety	IEC 61010-1 CSA C22.2 No. 1010.1 UL 3111

This ISM device complies with Canadian ICES-001.

Cet appareil ISM est conforme à la norme NMB-001 du Canada.

Declaration of Conformity

 Agilent Technologies	DECLARATION OF CONFORMITY According to ISO/IEC Guide 22 and CEN/CENELEC EN 45014	
Manufacturer's Name: <i>Agilent Technologies, Inc.</i>		
Manufacturer's Address: <i>Network Systems Test Division (NSTD) 5070 Centennial Boulevard Colorado Springs, Colorado 80919 United States of America</i>		
Declares that the products,		
Product Name: <i>VQT (Voice Quality Tester) Portable Analyzers</i>		
Model Number: <i>J1981A and J1981B</i>		
Product Options: <i>This declaration covers all options of the above products.</i>		
Conform with the following product standards:		
EMC (Technical Construction File)	<i>The product herewith complies with the requirements of the EMC Directive 89/336/EEC (including 93/68/EEC) and carries the CE Marking accordingly (European Union).</i>	
	<i>Against: EMC test specifications EN 55011:1991 (Group 1, Class A) and EN 61326:1997</i>	
	<i>As detailed in: Electromagnetic Compatibility (EMC) Certificate of Conformance Report No. 1080/1/CBR, based on Technical Construction File (TCF) No. NSTD-EMC Program reference A-2961-2388-100 Revision A, dated 6 June 2001.</i>	
	<i>Assessed by: EMC Test Center, York EMC Services Limited Appointed Competent Body Fleming Building Donibristle Industrial Park Dalgety Bay Dunfermline, Fife KY11 9HZ United Kingdom</i>	
Safety	<i>IEC 61010-1:1990 + A1:1992 + A2:1995 / EN 61010-1:1993 + A2:1995 Canada: CSA C22.2 No. 1010.1:1992</i>	
Supplemental Information:		
23 May 2002 Date	 Neil Yosinski Name	
	Regulatory Manager Title	
For further information, please contact your local Agilent Technologies sales office, agent, or distributor.		
Revision: A.00.01	Issue Date: 23 MAY 2002	Document No. J1981-DoC-A.00.01

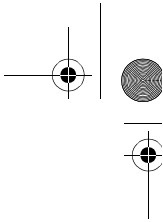
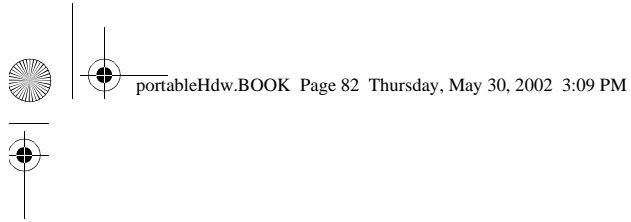

C Regulatory Information

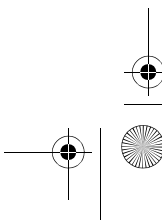
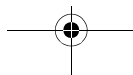
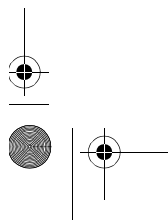
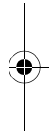



D Software and Operating System Recovery

Reinstalling Windows NT 4.0 84

Re-installing the VQT Software 86

In some cases, it may be necessary to re-install the VQT Portable Analyzer from the beginning. If you have to reinstall the Windows NT operating system, do that first and then reinstall the VQT software. If it is necessary to reinstall only the VQT software, you can go to “Re-installing the VQT Software” on page 86. Call your technical support representative if you have problems with this process.



D Software and Operating System Recovery

Reinstalling Windows NT 4.0

The purpose of the Operating System Recovery CD is to provide a means whereby you can restore your VQT Portable Analyzer unit to a generic configuration, containing only Windows NT 4.0. This process will restore the unit to a factory-installed configuration.

This process will erase ALL of the data on ALL of your hard drive partitions, so it should be used only when necessary. Any data or files that you have not backed up, or do not back up, will be lost after this procedure is completed.

Verify recovery CD version

Ensure that you use the correct Operating System Recovery CD for your VQT Portable Analyzer by checking this list:

- For VQT Portable Analyzers (J1981B) with serial numbers SG41370499 and lower, use the Operating System Recovery CD, part number 5012-2224.
- For VQT Portable Analyzers (J1981B) with serial numbers SG41370500 and higher, use the Operating System Recovery CD, part number 5012-2223.

In addition to the Operating System Recovery CD listed above, you will also need the recovery boot floppy (part number 5012-1462) delivered with your system.

Once this procedure is complete, you can reinstall the Agilent VQT software suite using its own software CD, supplied separately.

WARNING

You should back up any files or data that cannot be recovered from other sources before beginning this procedure.

Re-image the VQT Portable Analyzer

This procedure is pre-configured to work with the internal CD-ROM drive and floppy drive of the VQT Portable Analyzer. It will not work with an external CD-ROM drive.

- 1 If possible, back up all data contained on your hard drive. This process erases all data on the hard drive partitions.
- 2 Plug the VQT Portable Analyzer into the outlet using the supplied power cord.

CAUTION

The following steps must be performed quickly, or else the VQT Portable Analyzer may attempt to boot from the hard drive.

- 3 Insert the Recovery Boot Disk (part number 5012-1462) into the internal floppy drive.
- 4 Insert the Operating System Recovery CD into the internal CD-ROM drive of the VQT Portable Analyzer.

NOTE

The CD-ROM drive will not eject without power being supplied to the VQT unit. After inserting the CD into the drive, close the drive tray.

- 5 Turn on the VQT Portable Analyzer or cycle the power by restarting it so the device will boot using the floppy disk.
- 6 Follow the on-screen instructions.

This process should take approximately 15 minutes. Once this process is completed, your system will be restored to a Windows NT 4.0 configuration. You will need to reinstall the Agilent VQT software separately using its software CD.

D Software and Operating System Recovery

Re-installing the VQT Software

If it is necessary to reinstall the VQT software onto the VQT Portable Analyzer, use the following instructions. These instructions can be performed separately from “Reinstalling Windows NT 4.0” on page 84, if reinstalling the VQT software is all that is necessary.

- 1 Insert the VQT software CD in the CD-ROM drive on the VQT Portable Analyzer.
- 2 Click the Windows Start button and select Run. The Run dialog box appears.
- 3 Type: `d:\setup.exe` and click OK. (Replace “d” with the drive letter assigned to the CD-ROM drive on the VQT Portable Analyzer, if different.)
- 4 Accept the defaults that appear during the installation process.
- 5 When prompted, select the appropriate software for your hardware configuration in the Application Selection dialog box, such as Analog VQT, T1 and E1 VQT, and so on.
- 6 When the installation process is complete, remove the CD from the drive and restart the VQT Portable Analyzer.

Index

Numerics

- 10/100 acquisition hardware, 57
- 10/100 Ethernet connection diagram, 59
- 10/100 Ethernet interface, 26
- 10/100 Ethernet internal NIC, 26
- 10/100 Ethernet NIC, 23

A

- acquisition hardware
 - 10/100 Ethernet, 57
 - E1, 53
- audio control, 24
- AutoRun, 35
- Autorun.cfg, 37

C

- cables
 - 10/100 Ethernet, 33, 57
 - crossover cables, 55
 - crossover cables (J1981-61601), 56
 - ground cable, 49, 50
 - maximum length, 69, 71
 - maximum lengths, 71
 - requirements, 69, 71
 - RJ-11 cable, 46
 - RJ-45 LED interpretation, 70, 71
 - straight-through cable (J1981-61602), 56
- client license key, 30, 40, 42, 43
- client software license, 15
- configuring a VQT Portable Analyzer, 19
- connecting the VQT Portable Analyzer, 20
- connections
 - E&M, 48
 - RJ-45, 48

- controlling PC, 16, 32
 - configuring for IP connectivity, 43
 - entering the client license key, 43
 - installing the VQT software, 41
 - requirements, 41
 - setting up, 40

D

- documentation, 6

E

- E&M, 48
- E&M connection diagram, 47
- E&M port specifications, 66
- E1 acquisition hardware, 53
- E1 connection diagram, 55
- E1 port specifications, 67

F

- FCC Part 68 Disclaimer, 66
- FXO connection diagram, 46
- FXO port specifications, 66

G

- ground connections, 49

H

- How to ...
 - automatically start VQT server processes, 35
 - configure as a server, 33
 - configure the internal NIC, 26
 - configure the IP connection, 32
 - configure the mouse, 25
 - set the watchdog timer, 36
 - set up a controlling PC, 40
 - set up a new VQT Portable Analyzer, 23
 - set up a printer, 25
 - upgrade an existing VQT Portable Analyzer, 28
 - upgrade the hardware, 31
 - upgrade the VQT software, 29

I

- interfaces
 - 10/100 Ethernet, 57
 - E&M, 45
 - E1, 53, 54
 - FXO, E&M, T1, E1, 10/100, 10
 - FXO, 45
 - T1, 53
- IP network, 21

L

- license
 - 10/100 Ethernet VoIP interface license, 12, 31, 58
 - client license key, 30, 42, 43
 - client software license, 11, 15
 - Windows NT registration, 24
- Logistical, 22
- logistical concerns, 22

Index

M

mouse, 23, 25

N

network under test, 21

networks

IP, 21

network under test, 21

SIP, H.323, 12

NIC

10/100 Ethernet (built-in)
specifications, 69

10/100 Ethernet (optional)
specifications, 70

configuring the internal NIC, 75

configuring the second NIC, 77

how to use two NICs, 57

installing the second NIC, 73

P

PCMCIA ports, 23

planning your test strategy, 18, 21

platform, 13

printer, 25

R

remote testing, 15, 32

configuring the network IP, 32

configuring the server, 33

remotely controlled, 16

RJ-45 connections, 48

S

server

See VQT server

setting up a VQT Portable Analyzer, 19

single-server testing, 14

Start VQT Servers icon, 34

T

T1 acquisition hardware, 53

T1 connection diagram, 54

T1 port specifications, 67

test scenarios

remote or distributed testing, 32

roles of test equipment, 21

U

upgrade

hardware (test interfaces), 31

software, 29

V

volume, 24

VQT Portable Analyzer

as a controlling PC, 32

configuring a mouse, 25

configuring the VQT Portable
Analyzer, 19

configuring Windows NT, 24

connecting to the network under
test, 20

introduction, 10

part number, 10

platform overview, 13

remotely controlled, 16

setting up, 19, 23

setting up a printer, 25

setting up as controlling PC, 40

upgrading hardware, 31

upgrading software, 29

what can it do?, 13

VQT server

automatically starting, 35

configuring VQT Portable Analyzer, 33

manually starting, 34

setting the watchdog timer, 36

VQT software

client software license, 11

introduction, 11

starting, 20, 60

Welcome screen, 20

VQT test system

IP network, network under test, 21

planning, 18, 21

test roles of VQT equipment, 21

W

watchdog timer, 36

Windows NT operating system

configuration, 24