



Advanced Test Equipment Rentals
www.atecorp.com 800-404-ATEC (2832)

Agilent E4980A Precision LCR Meter

Service Guide

Fifth Edition

FIRMWARE REVISIONS

This manual applies directly to instruments that have the firmware revision A.01.00 or higher.

For additional information about firmware revisions, see Appendix A.



Agilent Technologies

Agilent Part No. E4980-90120

August 2010

Notices

The information contained in this document is subject to change without notice.

This document contains proprietary information that is protected by copyright. All rights are reserved. No part of this document may be photocopied, reproduced, or translated to another language without the prior written consent of Agilent Technologies.

Microsoft®, MS-DOS®, Windows®, Visual C++®, Visual Basic®, VBA® and Excel® are registered

UNIX is a registered trademark in U.S. and other countries, licensed exclusively through X/Open Company Limited.

Portions ©Copyright 1996, Microsoft Corporation. All rights reserved.

© Copyright 2006, 2007, 2008, 2010 Agilent Technologies

Manual Printing History

The manual's printing date and part number indicate its current edition. The printing date changes when a new edition is printed. (Minor corrections and updates that are incorporated at reprint do not cause the date to change.) The manual part number changes when extensive technical changes are incorporated.

March 2006	First Edition (part number: E4980-90100)
April 2006	Second Edition (part number: E4980-90100)
October 2007	Third Edition (part number: E4980-90110)
August 2008	Fourth Edition (part number: E4980-90120)
August 2010	Fifth Edition (part number: E4980-90120)

Safety Summary

The following general safety precautions must be observed during all phases of operation, service, and repair of this instrument. Failure to comply with these precautions or with specific WARNINGS elsewhere in this manual may impair the protection provided by the equipment. Such noncompliance would also violate safety standards of design, manufacture, and intended use of the instrument. Agilent Technologies assumes no liability for the customer's failure to comply with these precautions.

-
- NOTE** The E4980A complies with INSTALLATION CATEGORY II as well as POLLUTION DEGREE 2 in IEC61010-1. The E4980A is an INDOOR USE product.
-
- NOTE** The LEDs in the E4980A are Class 1 in accordance with IEC60825-1, CLASS 1 LED PRODUCT
-
- NOTE** This equipment is MEASUREMENT CATEGORY I (CAT I). Do not use for CAT II, III, or IV.
-
- NOTE** This equipment is tested with stand-alone condition or with the combination with the accessories supplied by Agilent Technologies against the requirement of the standards described in the Declaration of Conformity. If it is used as a system component, compliance of related regulations and safety requirements are to be confirmed by the builder of the system.
-
- **Ground the Instrument**

To avoid electric shock, the instrument chassis and cabinet must be grounded with the supplied power cable's grounding prong.
 - **DO NOT Operate in an Explosive Atmosphere**

Do not operate the instrument in the presence of inflammable gasses or fumes. Operation of any electrical instrument in such an environment clearly constitutes a safety hazard.
 - **Keep Away from Live Circuits**

Operators must not remove instrument covers. Component replacement and internal adjustments must be made by qualified maintenance personnel. Do not replace components with the power cable connected. Under certain conditions, dangerous voltage levels may remain even after the power cable has been disconnected. To avoid injuries, always disconnect the power and discharge circuits before touching them.
 - **DO NOT Service or Adjust the Instrument Alone**

Do not attempt internal service or adjustment unless another person, capable of rendering first aid and resuscitation, is present.
 - **DO NOT Substitute Parts or Modify the Instrument**

To avoid the danger of introducing additional hazards, do not install substitute parts or perform unauthorized modifications to the instrument. Return the instrument to an Agilent Technologies Sales and Service Office for service and repair to ensure that

safety features are maintained in operational condition.

- Dangerous Procedure Warnings

Warnings, such as the example below, precede potentially dangerous procedures throughout this manual. Instructions contained in the warnings must be followed.

WARNING

Dangerous voltage levels, capable of causing death, are present in this instrument. Use extreme caution when handling, testing, and adjusting this instrument.

- Do not connect the measuring terminals to mains.

Safety Symbols

General definitions of safety symbols used on the instrument or in manuals are listed below.



Instruction Manual symbol: the product is marked with this symbol when it is necessary for the user to refer to the instrument manual.



Alternating current.



Direct current.



On (Supply).



Off (Supply).



In position of push-button switch.



Out position of push-button switch.



Frame (or chassis) terminal. A connection to the frame (chassis) of the equipment which normally include all exposed metal structure.



Stand-by.

WARNING

This warning sign denotes a hazard. It calls attention to a procedure, practice, condition or the like, which, if not correctly performed or adhered to, could result in injury or death to personnel.

CAUTION

This Caution sign denotes a hazard. It calls attention to a procedure, practice, condition or the like, which, if not correctly performed or adhered to, could result in damage to or destruction of part or all of the product.

NOTE

Note denotes important information. It calls attention to a procedure, practice, condition or the like, which is essential to highlight.

Certification

Agilent Technologies certifies that this product met its published specifications at the time of shipment from the factory. Agilent Technologies further certifies that its calibration measurements are traceable to the United States National Institute of Standards and Technology, to the extent allowed by the Institution's calibration facility, or to the calibration facilities of other International Standards Organization members.

Documentation Warranty

The material contained in this document is provided "as is," and is subject to being changed, without notice, in future editions. Further, to the maximum extent permitted by applicable law, Agilent disclaims all warranties, either express or implied with regard to this manual and any information contained herein, including but not limited to the implied warranties of merchantability and fitness for a particular purpose. Agilent shall not be liable for errors or for incidental or consequential damages in connection with the furnishing, use, or performance of this document or any information contained herein. Should Agilent and the user have a separate written agreement with warranty terms covering the material in this document that conflict with these terms, the warranty terms in the separate agreement will control.

Exclusive Remedies

The remedies provided herein are buyer's sole and exclusive remedies. Agilent Technologies shall not be liable for any direct, indirect, special, incidental, or consequential damages, whether based on contract, tort, or any other legal theory.

Assistance

Product maintenance agreements and other customer assistance agreements are available for Agilent Technologies products.

For any assistance, contact your nearest Agilent Technologies Sales and Service Office. Addresses are provided at the back of this manual.

Typeface Conventions

Sample (bold)

Boldface type is used for emphasis.

Sample (Italic)

Italic type is used for emphasis and manual title.

[Sample] key

Indicates a hardkey (key on the front panel or external keyboard) labeled “Sample.” “key” may be omitted.

Sample menu/button/box

Indicates a menu/button/box on the screen labeled “Sample” which can be selected/executed by clicking “menu,” “button,” or “box” may be omitted.

Sample 1 - Sample 2 - Sample 3

Indicates a sequential operation of **Sample 1**, **Sample 2**, and **Sample 3** (menu, button, or box). “-” may be omitted.

1. General Information	
Organization of Service Guide	14
Instruments Covered by This Manual	15
Required Equipment	16
2. Performance Test	
Introduction	18
Test Equipment Required	18
Individual Test Description	19
1. Frequency Accuracy Test	19
2. DC Source Level Accuracy Test	19
3. DC Bias Level Accuracy Test	19
4. DC Bias V Level Monitor Accuracy Test	19
5. DC Bias I Level Monitor Accuracy Test	19
6. AC Signal Level Monitor Accuracy Test	19
7. AC Signal Level Accuracy Test	19
8. Impedance Measurement Accuracy Test	20
9. DCR Measurement Accuracy Test	20
3. Adjustment	
Safety Considerations	22
Warm-up for Adjustment	22
Required Equipment	22
Required Adjustment after Replacing Assembly	23
Writing ID	23
Write Null Phase Track Default Data	23
Null DC Offset Adjustment	23
Null ADC DC Offset Adjustment	23
ADC Linearity Adjustment	23
DC Bias Adjustment	24
DC Level V Monitor Adjustment	24
DC Level I Monitor Adjustment	24
DC Source Adjustment	24
DCR Adjustment	24
Impedance Adjustment	24
AC Level Monitor Adjustment	24
OSC Level Adjustment	24
4. Troubleshooting	
Introduction	26
To Troubleshoot the Instrument	27
Primary Trouble Isolation	27
Power On Sequence Troubleshooting	29
Check the Line Voltage and Fuse	29
Check the Power Supply Unit Output	29
Check booting process	31
Troubleshooting Using Service Function	32
Power On Test	32

Contents

Contents of the power on test results	32
Self Test	32
SERVICE Page	34
Power On Test / Self Test Failure Troubleshooting	38
Function Specific Troubleshooting	40
To Check the Front Panel	41
To Check the LCD	41
To Check the Front USB port	41
To Check the External Trigger Input	42
To Check the LAN	42
To Check the GPIB	44
To Check the USB (USBTMC) Interface Card	45
To Check the Handler Interface Function (Option 201 only)	45
To Check the Scanner Interface Function (Option 301 only)	49
To Check the Bias Current Interface Function (Option 002 only)	53
Performance test failure troubleshooting	57
Recommended adjustment for performance test failure	57
Adjustment failure troubleshooting	58
Performance test failure troubleshooting	59

5. Replaceable Parts

Ordering Information	62
Direct Mail Order System	62
Exchange Assemblies	62
Replaceable Parts List	63
Power Cables and Plug Configurations	63
Top View (Major Assemblies)	64
Top View (Cables)	66
Top View (Miscellaneous Parts)	68
Top View (Tested PCA A2 (Analog Board))	69
Front Panel	70
Top View (Power Supply Assembly)	73
Top View (Base Plate Assembly)	75
Gasket	77
Rear View	78
Power Inlet Assembly	79
Fan Assembly	80
Interface Option Assembly	81
Wind Angle Assembly	82
Label Assembly	83
Bumpers & Handle Assembly	84
Other Parts	85

6. Replacement Procedure

Replacing an Assembly	88
Required Tools	89
3/4 Rack Module Top Replacement	90
Tools Required	90

Removal Procedure	90
Replacement Procedure	90
A3 Analog Daughter Board Replacement	94
Tools Required	94
Removal Procedure	94
Replacement Procedure	94
A2 Analog Board Replacement	96
Tools Required	96
Removal Procedure	96
Replacement Procedure	96
Front Panel Assembly Removal	98
Tools required	98
Removal Procedure	98
Replacement Procedure	98
Option Interface Replacement	99
Tools Required	99
Removal Procedure	99
Replacement Procedure	99
PPMC PCA Replacement	101
Tools Required	101
Removal Procedure	101
Replacement Procedure	101
A1 Mother Board Replacement	103
Tools Required	103
Removal Procedure	103
Replacement Procedure	103
Power Supply Assembly Replacement	105
Tools Required	105
Removal Procedure	105
Replacement Procedure	105
Base Plate Replacement	107
Tools Required	107
Removal Procedure	107
Replacement Procedure	107
Rear Panel Assembly Replacement	109
Tools Required	109
Removal Procedure	109
Replacement Procedure	109
FAN Assembly Replacement	111
Tools Required	111
Removal Procedure	111
Replacement Procedure	111
GPIB Cable Replacement	113
Tools Required	113
Removal Procedure	113
Replacement Procedure	113
Power Inlet Assembly Replacement	115
Tools Required	115
Removal Procedure	115

Contents

Replacement Procedure	115
PCA E4980 USB Replacement	117
Tools Required	117
Removal Procedure.	117
Replacement Procedure	117
Binding Post Sgl Replacement.	118
Tools Required	118
Removal Procedure.	118
Replacement Procedure	118
Inverter Replacement	120
Tools Required	120
Removal Procedure.	120
Replacement Procedure	120
Front Panel, Key Pad, and Key Flex Circuit Replacement	122
Tools Required	122
Removal Procedure.	122
Replacement Procedure	122
Display Interface Replacement.	124
Tools Required	124
Removal Procedure.	124
Replacement Procedure	124
7. Post-Repair Procedures	
Post-Repair Procedures	128
A. Manual Changes	
Manual Changes	132
B. Firmware Update	
Update the E4980A firmware using USB/GPIB interface	134
Required Equipment	134
How to update E4980A firmware using USB/GPIB interface	134
Update the E4980A firmware using USB cable.	135
Required Equipment	135
How to update E4980A firmware using USB cable.	135
C. Power Requirement	
Replacing Fuse	138
Fuse Selection	138
Setting up the fuse.	138
Power Requirements.	139
Power Cable	139
D. Error Messages	
Error Messages	142
A	142
B	142
C	142

D 143
E 144
F 144
G 145
H 145
I 145
M 146
N 146
O 146
P 147
Q 147
R 148
S 148
T 148
U 148
V 149
Warning Message 150
 Numeric 150
 A 150
 C 150
 I 150
 S 151

1 General Information

This Service Guide is a guide to servicing the E4980A 20 Hz to 2 MHz Precision LCR Meter. The Service Guide provides information about performance test, adjustment, troubleshooting, and repairing the E4980A.

Organization of Service Guide

Tabs are used to divide the major chapter and appendix of this manual. The contents of each chapter and appendix in this manual as follows.

- Chapter 1, “General Information.”

This Service Guide is a guide to servicing the E4980A 20 Hz to 2 MHz Precision LCR Meter. The Service Guide provides information about performance test, adjustment, troubleshooting, and repairing the E4980A.
- Chapter 2, “Performance Test.”

This chapter provides the outline of the E4980A performance tests.
- Chapter 3, “Adjustment.”

This chapter provides the adjustment information for the E4980A to ensure that it is within its specifications. The adjustment must be performed Agilent’s qualified service personnel. If you need the adjustment for your E4980A, it should be sent to the nearest Agilent Technologies service office.
- Chapter 4, “Troubleshooting.”

This chapter provides the procedure to isolate a faulty assembly in the E4980A.
- Chapter 5, “Replaceable Parts.”

This chapter contains information for ordering replacement parts for the E4980A.
- Chapter 6, “Replacement Procedure.”

This chapter provides procedure for removing and replacing the major assemblies in the E4980A.
- Chapter 7, “Post-Repair Procedures.”

This chapter lists the procedures required to verify the E4980A operation after an assembly is replaced with a new one.
- Appendix A, “Manual Changes.”

This appendix contains the information required to adapt this manual to versions or configurations of the E4980A manufactured earlier than the current printing date of this manual. The information in this manual applies directly to E4980A units with the serial number that is printed on the title page of this manual.
- Appendix B, “Firmware Update.”

This appendix describes how to update the E4980A firmware. When you want to update the E4980A firmware, refer to this appendix.
- Appendix C, “Power Requirement.”
- Appendix D, “Error Messages.”

The Agilent E4980A provides error messages to indicate its operating status. This appendix describes the error messages of the E4980A in alphabetical order.

Instruments Covered by This Manual

The ten-character serial number is stamped on the serial number plate (Figure 1-1) on the rear panel.

Figure 1-1

Serial Number Label

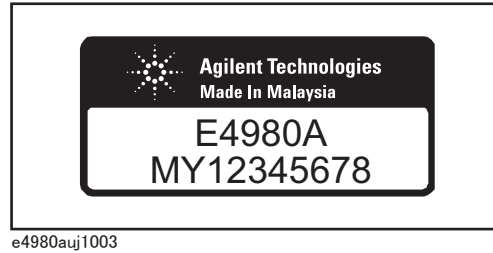

An instrument manufactured after the printing date of this manual may have serial number prefix that is not listed on the title page. This unlisted serial number prefix indicates the instrument is different from those described in this manual. The manual for this new instrument may be accompanied by a yellow *Manual Changes* supplement or have a different manual part number. This sheet contains “change information” that explains how to adapt the manual to the newer instrument.

In addition to change information, the supplement may contain information for correcting errors (Errata) in the manual. To keep this manual as current and accurate as possible, Agilent Technologies recommends that you periodically request the latest *Manual Changes* supplement. The supplement for this manual is identified by this manual’s printing data and is available from Agilent Technologies. If the serial prefix or number of an instrument is lower than that on the title page of this manual, see *Appendix A, Manual Changes*. For information concerning a serial number prefix that is not listed on the title page or in the *Manual Changes* supplement, contact the nearest Agilent Technologies office.

Required Equipment

Table 1-1 lists the recommended equipment for performance test, adjustment and troubleshooting for E4980A.

Table 1-1 Recommended Test Equipment

Equipment	Critical Specifications	Recommended Model	Qty.	Use* ¹
Frequency Counter	Frequency Range: 1 MHz Time Base Error < 50 ppm/year	Agilent 53181A	1	P
Digital Multimeter	No Substitute	Agilent 3458A	1	P,A
Standard Capacitors Set	No Substitute	16380A	1	P,A
Standard Capacitors Set	No Substitute	16380C with option 001	1	P
Four Terminal Pair Standard Resistor Set	No Substitute	Agilent 42030A	1	P,A
4TP Open Termination	No Substitute	Agilent 42090A	1	P,A
4TP Short Termination	No Substitute	Agilent 42091A	1	P,A
Test Leads (BNC), 1 m	No Substitute	Agilent 16048A	1	P,A
Test Leads (BNC), 2 m	No Substitute	Agilent 16048D	1	P,A
Test Leads (BNC), 4 m	No Substitute	Agilent 16048E	1	P,A
DC Power Supply	+ 5V, 0.1A	Agilent E3610A	1	T
Handler Simulator	No Substitute	p/n 04278-65001	1	T
Scanner Simulator	No Substitute	p/n 04278-65301	1	T
Bias Interface Simulator	No Substitute	p/n 42841-65001	1	T
Bias Interface Cable	GP-IO Cable	p/n 42841-61640	1	T
Interface Box	No Substitute	p/n 04294-61002	1	P,A
Cables	BNC(m)-BNC(m) Cable, 122 cm	p/n 8120-1840	1	P,A
Adapter	BNC(f)-BNC(f) Adapter	p/n 1250-1830	4	P,A
	Dual Banana-BNC(f) Adapter	p/n 1251-2277	1	P,A

*1.P:Performance Test A:Adjustment T:Troubleshooting

2 Performance Test

This chapter provides the outline of the E4980A performance tests.

Introduction

This chapter provides the performance tests outline for Agilent E4980A. The performance test names are listed in Table 2-1. The test descriptions are described sequentially in the following pages.

NOTE Allow the analyzer to warm up for at least 30 minutes before you execute any of the performance tests.

Perform all performance tests in an ambient temperature of 23 ± 5 °C

NOTE The performance tests should be performed periodically. The recommended test interval is 12 months.

The test interval depends on maintenance and the environmental conditions under which the instrument is used. You may find that the interval could be shortened or lengthened; however, such a decision should be based on substantial quantitative data.

Table 2-1 List of the E4980A performance tests

Para.	Title
1	Frequency Accuracy Test
2	DC Source Level Accuracy Test
3	DC Bias Level Accuracy Test
4	DC bias V Level Monitor Accuracy Test
5	DC bias I Level Monitor Accuracy Test
6	AC Signal Level Monitor Accuracy Test
7	AC Signal Level Accuracy Test
8	Impedance Measurement Accuracy Test
9	DCR Measurement Accuracy Test

Test Equipment Required

The required equipment for the performance test is listed in Table 1-1. Use only calibrated equipment when doing the performance test.

Individual Test Description

1. Frequency Accuracy Test

Description

This test checks the frequency accuracy of the E4980A test signal. The frequency accuracy is checked at 1MHz with a frequency counter. Since the E4980A employs a Direct Digital Synthesizer for the signal source, the frequency accuracy test at this frequency point can verify the accuracy for the entire frequency range.

2. DC Source Level Accuracy Test

Description

This test checks the DC source level accuracy of the E4980A DC source port output signal.

3. DC Bias Level Accuracy Test

Description

This test checks the DC bias level accuracy of the E4980A DC bias signal.

4. DC Bias V Level Monitor Accuracy Test

Description

This test checks the DC bias V level monitor accuracy of the E4980A. (Option : 001 only)

5. DC Bias I Level Monitor Accuracy Test

Description

This test checks the DC bias I level monitor accuracy of the E4980A. (Option : 001 only)

6. AC Signal Level Monitor Accuracy Test

Description

This test checks the AC signal level monitor accuracy of the E4980A.

7. AC Signal Level Accuracy Test

Description

This test checks the AC signal level accuracy of the E4980A output signal.

8. Impedance Measurement Accuracy Test

Description

This test checks the impedance measurement accuracy of the E4980A.

9. DCR Measurement Accuracy Test

Description

This test checks the DCR measurement accuracy of the E4980A. (Option : 001 only)

3 Adjustment

This chapter provides the adjustment information for the E4980A to ensure that it is within its specifications. The adjustment must be performed Agilent's qualified service personnel. If you need the adjustment for your E4980A, it should be sent to the nearest Agilent Technologies service office.

Safety Considerations

This manual contains NOTES, CAUTIONs, and WARNINGs that must be followed to ensure the safety of the operator and to keep the instrument in a safe and serviceable condition. The adjustment must be performed by Agilent's qualified service personnel.

WARNING

Any interruption of the protective ground conductor (inside or outside the equipment) or disconnection of the protective ground terminal can make the instrument dangerous. Intentional interruption of the protective ground system for any reason is prohibited.

Warm-up for Adjustment

Warm-up the E4980A for at least 30 minute before performing any of the following Adjustment procedures to ensure proper results and correct instrument operation.

Required Equipment

Table 1-1 on page 16 lists the equipment required to perform the Adjustment procedures described in this chapter. Use only calibrated test equipment when adjusting the E4980A.

Required Adjustment after Replacing Assembly

After replacing the following assembly, the adjustment items described in Table 3-1 must be required. The adjustment must be performed Agilent's qualified service personnel. If you need the adjustment for your E4980A, it should be sent to the nearest Agilent Technologies service office.

Table 3-1 Required Adjustment Item after Replacing Assembly

Replaced Assembly	Adjustment Item												
	Writing ID	Write Null phase track default data	Null DC offset Adjustment	Null ADC DC offset Adjustment	ADC linearity Adjustment	DC Bias Adjustment	DC Level V monitor Adjustment	DC Level I monitor Adjustment	DC Source Adjustment	DCR Adjustment	Impedance Adjustment	AC Level monitor Adjustment	OSC Level Adjustment
PPMC PCA													
A1 Board	√												
A2 Board		√	√	√	√	√	√	√	√	√	√	√	√
A3 Board		√	√	√	√	√	√	√	√	√	√	√	√

Writing ID

This item writes the serial number, option information into the A1 board of the E4980A.

Write Null Phase Track Default Data

The purpose of this procedure is to write the null phase track default data into A2 board

Null DC Offset Adjustment

The purpose of this procedure is to adjust the null dc offset of the A2 board.

Null ADC DC Offset Adjustment

The purpose of this procedure is to adjust the null adc dc offset of the A2 board.

ADC Linearity Adjustment

The purpose of this procedure is to adjust ADC non-linearity of the A2 board.

DC Bias Adjustment

The purpose of this procedure is to adjust the DC Bias level.

DC Level V Monitor Adjustment

The purpose of this procedure is to adjust the DC Level Monitor.

DC Level I Monitor Adjustment

The purpose of this procedure is to adjust the DC Level I Monitor.

DC Source Adjustment

The purpose of this procedure is to adjust the DC Source level.

DCR Adjustment

The purpose of this procedure is to adjust the DCR measurement.

Impedance Adjustment

The purpose of this procedure is to adjust the impedance measurement.

AC Level Monitor Adjustment

The purpose of this procedure is to adjust the AC level monitor.

OSC Level Adjustment

The purpose of this procedure is to adjust the OSC level.

4 Troubleshooting

This chapter provides the procedure to isolate a faulty assembly in the E4980A.

Introduction

WARNING These servicing instructions are for use by qualified personnel only. To avoid possible electrical shock, do not perform any servicing unless you are qualified to do so.

WARNING The opening of covers or removal of parts is likely to expose dangerous voltages. Disconnect the instrument from its power supply beforehand.

CAUTION Many of the assemblies in the instrument are very susceptible to damage from ESD (electrostatic discharge). Perform the following procedures only at a static-safe workstation and wear a grounding strap.

CAUTION DO NOT operate without following instructions. Programs or files in the instrument may be broken.

To Troubleshoot the Instrument

This section describes the basic procedural flow of troubleshooting when servicing the E4980A. The primary procedural tool in this section is the flowchart. The flowchart contains the entire troubleshooting path from a failure symptom to the isolation of faulty assembly, and will direct you to the completion of repair in an ordinary manner through the possible failure symptoms. Reference letters (Yes/No) on the flowcharts point to procedural steps that briefly explain the troubleshooting method to be performed next.

Primary Trouble Isolation

The primary trouble isolation in Figure 4-1 is to help direct you to the correct section for troubleshooting the E4980A.

Step 1. Turn the E4980A power on

With the E4980A plugged in and the power turned off, the front panel orange standby LED should be on. When the front panel power switch is turned on, the orange LED should go out and the yellow-green LED should come on. Also, the fan should start rotating. In case of unexpected results, go to “Power On Sequence Troubleshooting” on page 29.

Step 2. Check the display

- The power on test is executed once automatically before the measurements start. If the power on test fails, go to “Troubleshooting Using Service Function” on page 32.
- If one of the following error messages **A1 EEPROM write error**, **CPU Bd EEPROM write error**, **CPU Bd FLASH ROM write error**, **Fan failed**, or **Power failed** is displayed during the measurement process, go to “Power On Sequence Troubleshooting” on page 29 (check booting process).

Step 3. Check the basic function

If the front-panel, LCD display, data storage, remote interface or another function (except for measurement part) does not work correctly, go to “Function Specific Troubleshooting” on page 40.

Step 4. Check the measurement function

If the E4980A fails any of the performance tests, go to “Performance test failure troubleshooting” on page 57.

A faulty part should be replaced as outlined in Chapter 5 which gives replacement procedures for each part. The procedures required after part replacement are given in Chapter 6.

Troubleshooting
To Troubleshoot the Instrument

Figure 4-1 Primary trouble isolation flowchart

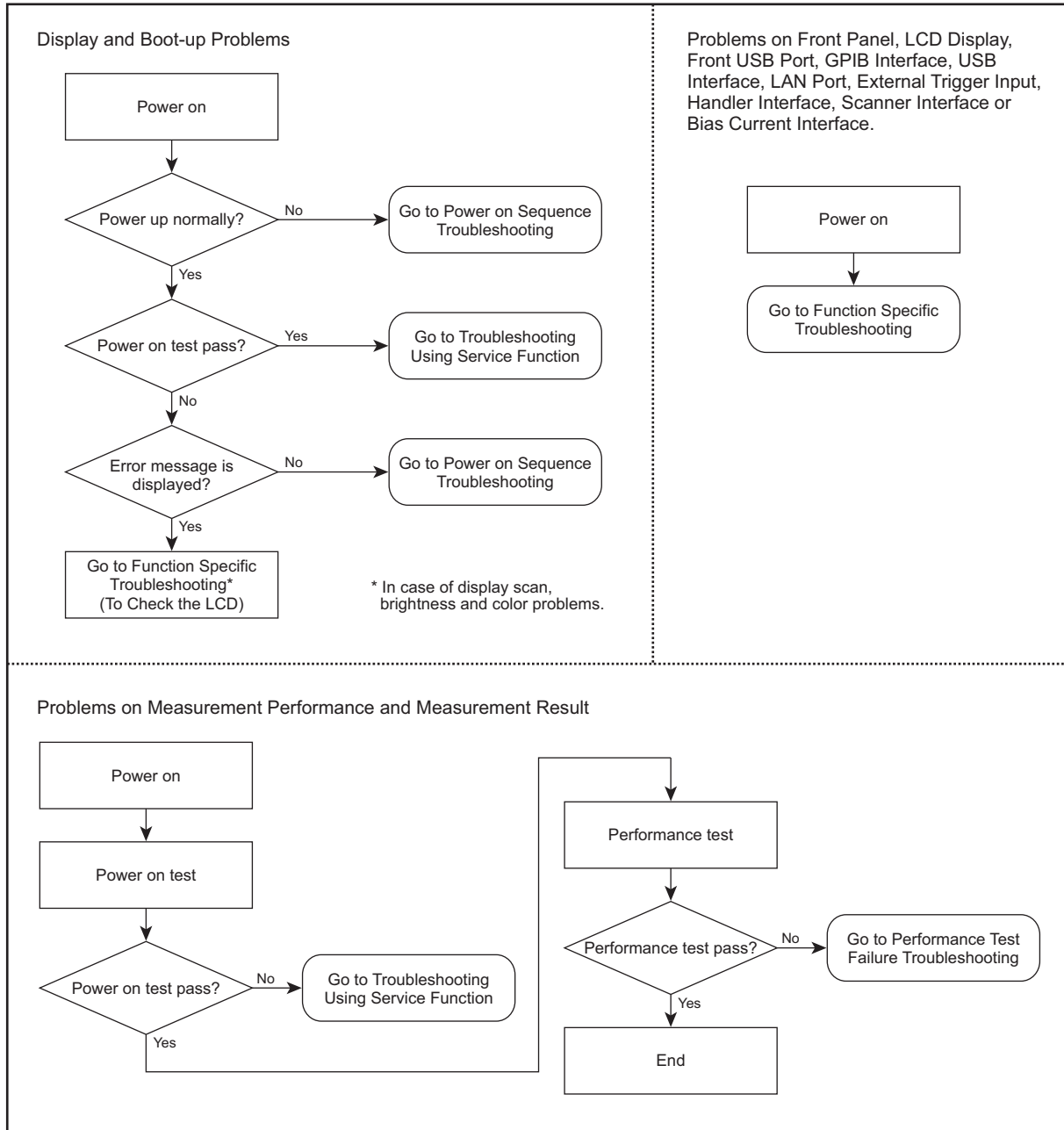

e4980ase1054

Power On Sequence Troubleshooting

Check the Line Voltage and Fuse

Check the main power line cord, power fuse, and actual line voltage to see that they are all correct. For more information about the line cord and power fuse, see the Power Requirements in Appendix B.

Check the Power Supply Unit Output

- Step 1.** Remove the E4980A's outer cover.
- Step 2.** Turn the E4980A power on.
- Step 3.** Measure the output voltage (+3.3, +5, +12, -12 V) of the power supply unit using a voltmeter with a small probe. The location of each voltage connector on the A1 board and A3 board is shown in Figure 4-2.

Figure 4-2 Output Voltage Location

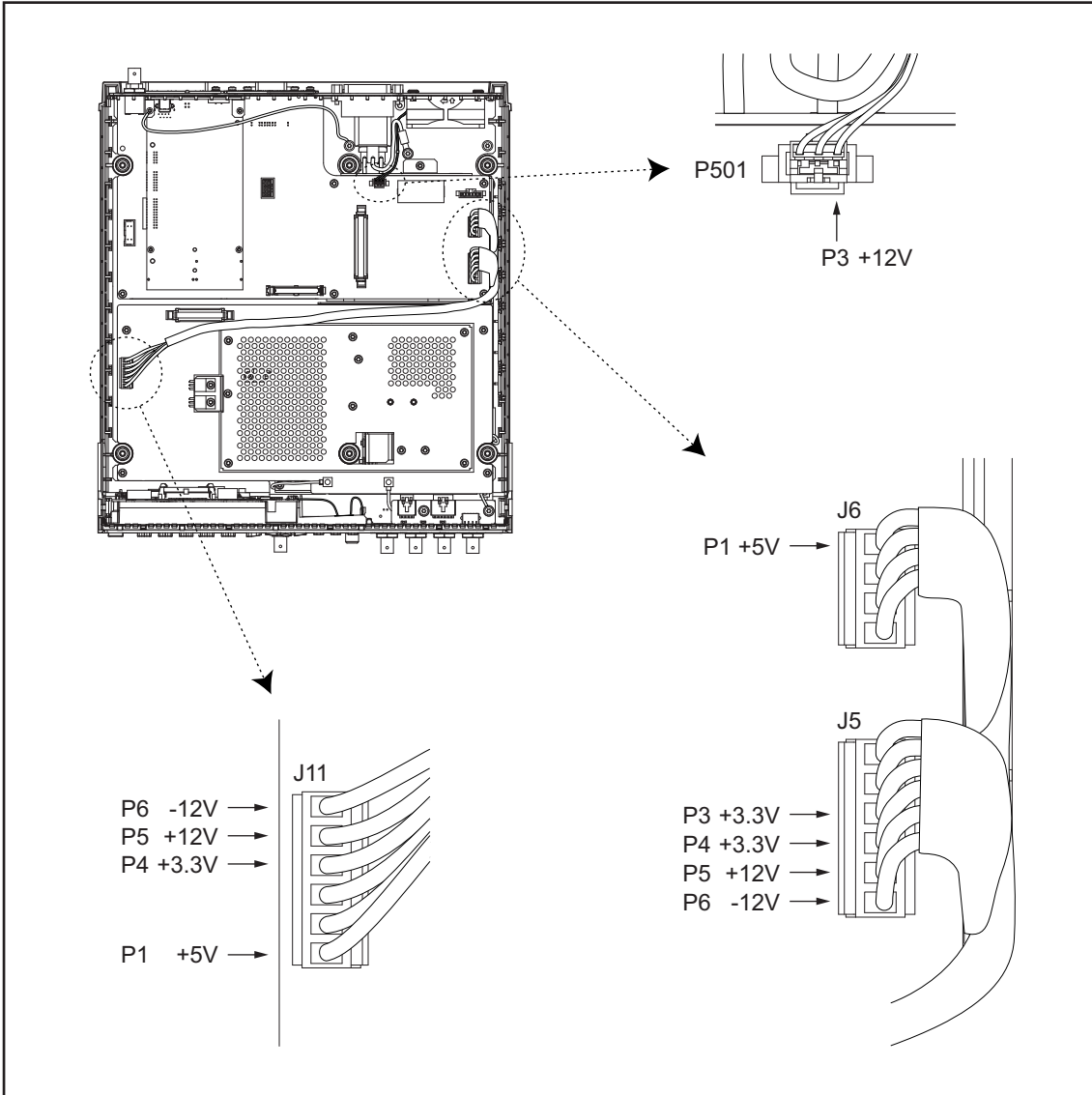

e4980ase1045

- If the voltmeter reading is not within the following limits, replace the power supply unit.

Table 4-1 Power Supply Unit Output

supply	Range
+ 3.3 V	+ 3.2 to + 3.4
+ 5 V	+ 4.8 to + 5.2
+ 12 V	+ 11.4 to + 12.6
- 12 V	- 11.4 to -12.6

- If the voltmeter reading is within the limits, the power supply is verified.

Check booting process

If the power on sequence has a problem despite it being powered from the power supply unit properly, check the following events in this order.

1. With the E4980A plugged in and the power turned off, the orange standby LED should be on. If the orange LED doesn't light, check the key flex circuit, display interface board, A1 board, and relevant cables.
2. When the front panel power switch is turned on, the orange LED should go out and the yellow-green LED should come on. If the yellow-green LED doesn't light, check the key flex circuit, display interface board, A1 board, and relevant cables.
3. Three LEDs (+3.3V, +5V, and PWR_GD) on the A1 board should be on. If the LEDs don't light, a problem in the A1 board is suspected.
4. The fan should be rotating and audible. If the fan doesn't run, it is probably defective.
5. Three LEDs for DC Source, DS Bias, and USB should be on temporarily. If these LEDs don't light, check the USB board, A1 board and the relevant cable.
6. The LED on the display interface board should blink. If the LED doesn't blink, check the display interface board, the A1 board, and the relevant cable.
7. Three LEDs for DC Source, DC Bias, and USB should go out.
8. The firmware revision and hardware option information along with copyright declaration should be displayed. If nothing is displayed, check the LCD, display interface board, inverter board, and the relevant cables.
9. The power on test should be executed once automatically before the measurement starts. If the power on test fails, an error code or an error message is displayed. For more details, refer to "Troubleshooting using service function".
10. The measurement view should be displayed.
11. If the following error message **A1 EEPROM write error** is displayed during the measurement process, a problem in the A1 board is suspected.
12. If the following error message **CPU Bd EEPROM write error**, or **CPU Bd FLASH ROM write error** is displayed during the measurement process, a problem in the PPMC PCA is suspected.
13. If the following error message **Fan failed** is displayed during the measurement process, a problem in the fan is suspected.
14. If the following error message **Power failed** is displayed during the measurement process, a problem in the power supply is suspected.

Troubleshooting Using Service Function

The Agilent E4980A has a service function to diagnose the analog measurement section, digital section, and internal dc power supply voltages. The Power On Test or Self Test of the service function makes it possible to isolate a faulty board assembly.

Power On Test

The Power On Test always takes place once the E4980A is turned on. When a failure is detected, a message "Power on test failed" is displayed in the system message area and the normal measurement screen does not appear (Service Mode). The Service Mode is a state that occurs when the power-on test fails. Here, the characters on the display turn yellow and all of the front panel keys are unavailable.

NOTE

When you want to use the front panel keys in the Service Mode while carrying out any repairs to the unit, Power Switch + Preset keys can be pressed. The characters on the display turn yellow too, but you can use all keys.

Contents of the power on test results

The Power On Test contains tests as shown in Table 4-4. If the power on test is failed, an error code or an error message is also displayed. You can identify a failure section with the error code or the error message. The error code or error message is related to each test group as shown in Table 4-4. For example, the first item of the error code is for CPU test group, second item is for System test group, and seventh item is for A3 test group. The value for each test group is given in hexadecimal.

Example of error code: Power on test failed: 0,0,0,0,0,3f,1f

NOTE

When the test no.1 or 2 of System test group fails, tests of A1, A2, A3 test groups are not performed. In case of this failure, the value for the fifth, sixth, and seventh item is indicated as ffff.

Self Test

The Self Test can perform some test items of the power on test. Pressing the [System] key followed by the **SELF TEST** softkey opens the SELF TEST page. The SELF TEST page, intended for maintenance and repair, allows you to check the digital and analog behavior of E4980A. You can choose one of the available test items with the cursor placed in the corresponding field (parenthesized field).

- Choosing a Test Item (TEST No. field)

Figure 4-3 shows the fields available on this page along with the softkeys corresponding to them.

Figure 4-3 SELF TEST Page

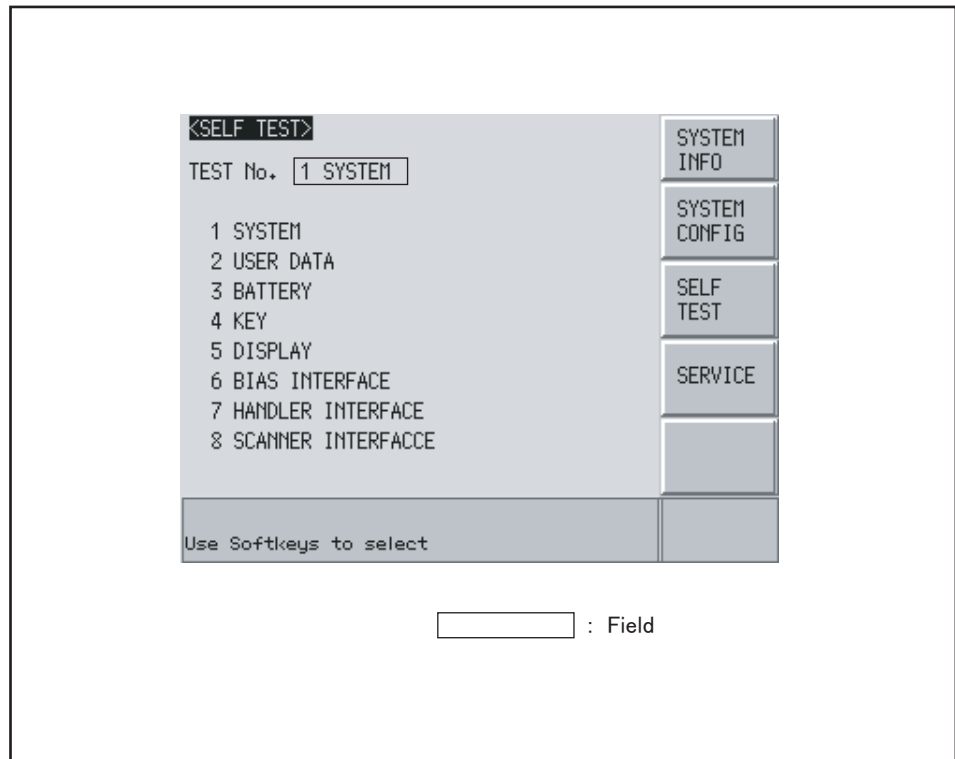

e4980aue1146

Choosing a Test Item

Functional Description E4980A can run the following self tests:

The tests of SYSTEM, USER DATA, and BATTERY are also performed by the power on test.

Table 4-2

Test item	Description
SYSTEM	Checks the entire system, A1/A2/A3 boards, system calibration data, and so on.
USER DATA	Checks the GPIB/LAN configurations, instrument configuration information, instrument calibration data, and scanner calibration data.
BATTERY	Checks the internal batteries.
KEY	Checks the front panel keys. (Visual checks only; no result shown on screen.)
DISPLAY	Checks the front panel LEDs and LCD. (Visual checks only; no result shown on screen.)
BIAS INTERFACE	Checks the bias interface. (Visual checks only; no result shown on screen.)

4. Troubleshooting

Table 4-2

Test item	Description
HANDLER INTERFACE	Checks the handler interface. (Visual checks only; no result shown on screen.)
SCANNER INTERFACE	Checks the scanner interface. (Visual checks only; no result shown on screen.)

Executing the self-test from the front panel The self-test of the E4980A can be executed from the front panel. The steps are given below.

Self-test procedure

- Step 4.** Press [System] - **SELF TEST**
- Step 5.** Use the cursor key to highlight the selection item to the right of “TEST No.” (1 in Figure 4-4)
- Step 6.** Select the number corresponding to the test that you want to perform by using the **INCR+** and **DECR-** softkeys.
- Step 7.** Press **EXECUTE - TEST START** (2 in Figure 4-4) to execute the selected test item.

Figure 4-4 Self-test screen and procedure

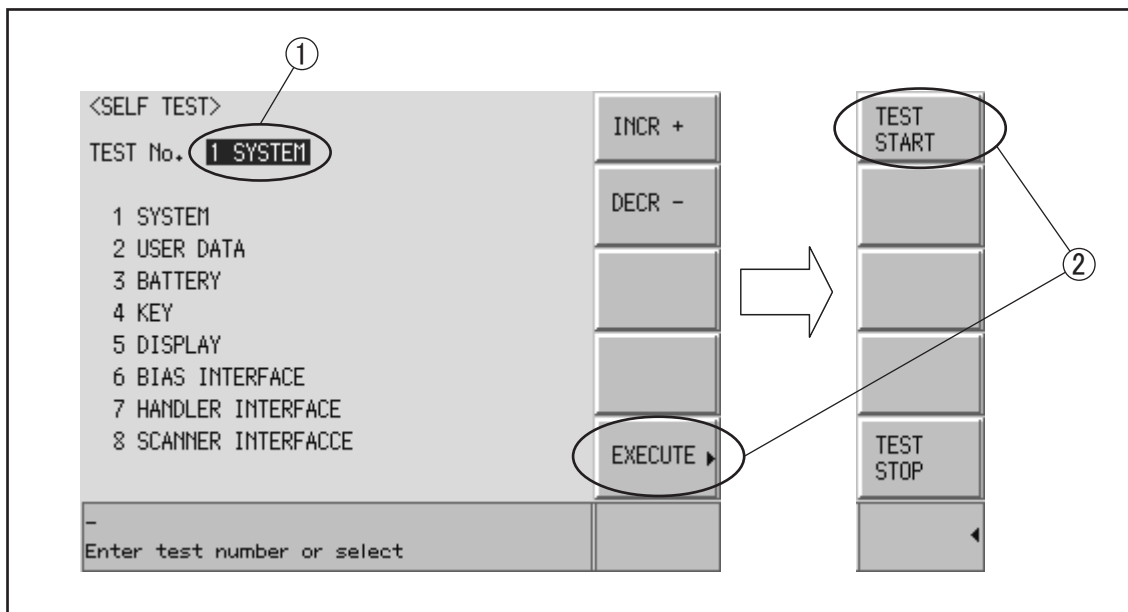

e4980auj1040

SERVICE Page

The results of the power on test or the self test (SYSTEM, USER DATA, and BATTERY) can be saved into a USB memory. Pressing the [System] key followed by the **SERVICE** softkey opens the SERVICE page.

This page is read-only.

This page displays the system information of E4980A and allows you to save the displayed information into the USB memory, but does NOT allow you to modify or delete the information.

NOTE The system information of E4980A may be used for the purposes of support and repair by Agilent Technologies, but will never be used for any other purposes.

Figure 4-5 SERVICE Page

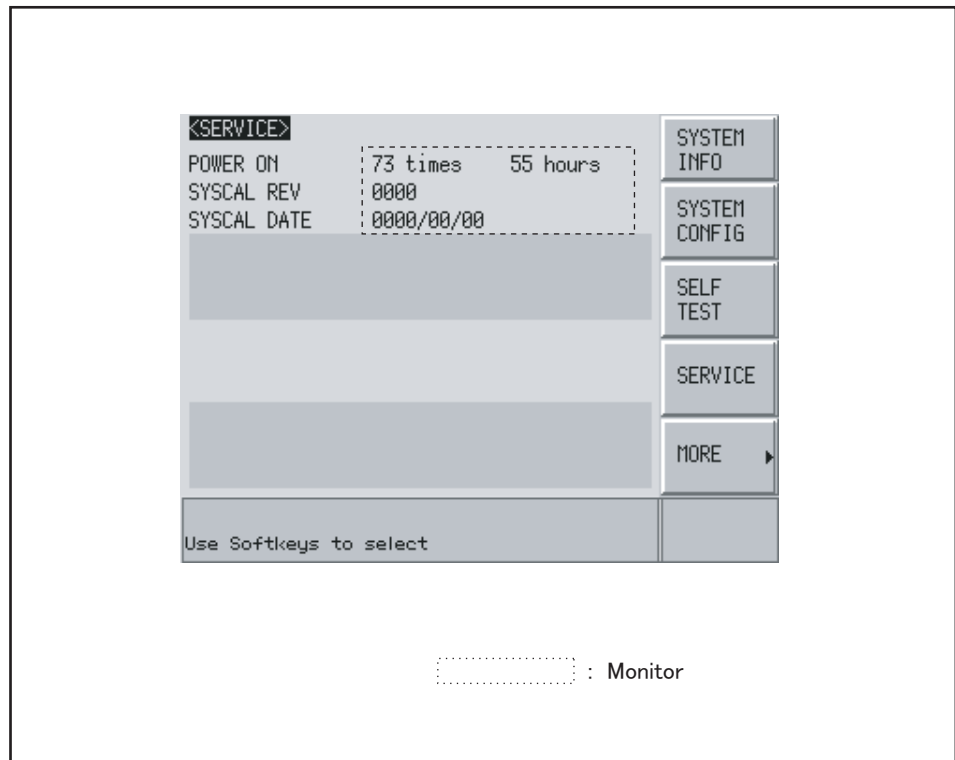

e4980aue1147

Monitor Information

The SERVICE page displays the following monitor information, which cannot be edited on the SERVICE page.

Table 4-3

Monitor Information	Description
POWER ON	Displays how many times E4980A have been started up and its cumulative power-on time.
SYSCAL REV	Displays the program revision of the adjustment for the E4980A.
SYSCAL DATE	Displays the date of the last adjustment for the E4980A.

Troubleshooting
Troubleshooting Using Service Function

Saving the System Information into External Memory

The system information of E4980A can be saved into external memory.

The system information may be used for the purposes of support and repair by Agilent Technologies.

The file location on the USB memory is as follows:

`\e4980a\system\sysinfo.txt`

NOTE

The system information of E4980A may be used for the purposes of support and repair by Agilent Technologies, but will never be used for any other purposes.

To save the system information into external memory:

- Step 1.** Plug a USB memory stick into the front USB port.
- Step 2.** Press [System].
- Step 3.** Press the **SERVICE** softkey.
- Step 4.** Press the **MORE** softkey.
- Step 5.** Press the **SAVE SYS INFO** softkey.
- Step 6.** While the data is being saved, a "PROCESSING..." message is shown on the display. When the data has been saved into the USB memory, a "Storing data completed." message appears in the system message area.

Example of the System Information

The sysinfo.txt can be read by using an external computer (PC). The example of the system information is as follows:

Example 4-1

System information

```
ID: Agilent Technologies,E4980A,MY12345678,A.01.00
OPT: 001,710,710
POWER CYCLE: 42
POWER ON HOURS: 22
SYSCAL REV: 1.00
SYSCAL DATE: 2006/3/9
R: Rev.1.00
CPU[1]: 0
CPU[2]: 0
SYST[1]: 0
SYST[2]: 0
SYST[3]: 0
SYST[4]: 0
SYST[5]: 0
DATA[1]: 0
DATA[2]: 0
DATA[3]: 0
```

DATA[4]: 0
OPT[1]: 0
OPT[2]: 0
OPT[3]: 0
OPT[4]: 0
OPT[5]: 0
OPT[6]: 0
OPT[7]: 0
A1[1]: -1.187504864E+01
A1[2]: +1.184382915E+01
A1[3]: +5.098754883E+00
A1[4]: +3.359375000E+00
A1[5]: +2.504882813E+00
A1[6]: +5.090893269E+00
A2[1]: -2.337981556E-04
A2[2]: -4.294419530E-01
A2[3]: +4.937164751E-01
A2[4]: +4.625371247E-01
A2[5]: -4.599838385E-01
A2[6]: +3.438261555E-01
A3[1]: -4.189105189E-05
A3[2]: -8.715481204E-01
A3[3]: +8.746015586E-01
A3[4]: -7.700712127E-01
A3[5]: +2.887844449E-01
USER[1]: 0
USER[2]: 0
USER[3]: 0
USER[4]: 0
BATT[1]: +3.247070313E+00
+3.750000000E+01
+4.474563461E-01
+4.404803338E-01

Power On Test / Self Test Failure Troubleshooting

Table 4-4 represents the contents of the power on tests or self test and the relationships of failed tests to probable faulty board assemblies. If power on test failed is displayed or self test fail is displayed, replace the faulty board assembly as shown in Table 4-4.

Table 4-4 Power on test / self test failure troubleshooting information

Test group	Test No.	Test Name	Error Code / Message	Probable faulty board assembly						
				A1	A2	A3	Bias IF	Handler	Scanner	PPMC
CPU	1	CPU Test	1 ~ ffff							###
	2	CPU Test	1 ~ ff							###
System	1	A1 FPGA check	0x01	###						#
	2	A2 FPGA check	0x02	##	###					#
	3	A1 Revision check	0x04	###						#
	4	A2 Revision check	0x08	##	###					
	5	A3 Revision check	0x10	##		###				
Data	1	System Data	0x01	###						#
	2	SysCal Data	0x02	##	###					#
	3	Flash File system check	0x04							###
	4	Test Limit Data	0x08							###
Option	1	Option 002 Off check	0x01	##			###			#
	2	Option 002 On check	0x02	##			###			#
	3	Option 201 Off check	0x04	##				###		#
	4	Option 201 On check	0x08	##				###		#
	5	Option 301 Off check	0x10	##					###	#
	6	Option 301 On check	0x20	##					###	#
	7	Option consistency check	0x40	##						#

Table 4-4 Power on test / self test failure troubleshooting information

Test group	Test No.	Test Name	Error Code / Message	Probable faulty board assembly						
				A1	A2	A3	Bias IF	Handler	Scanner	PPMC
A1	1	A1_DCBUS_M12V	0x01	###						
	2	A1_DCBUS_P12V	0x02	###						
	3	A1_DCBUS_P5V	0x04	###						
	4	A1_DCBUS_P3.3V	0x08	###						
	5	A1_DCBUS_P2.5V	0x10	###						
	6	A1_DCBUS_STANBY	0x20	###						
A2	1	A2_DCBUS_GND	0x01		###	#				
	2	A2_DCBUS_PM5V	0x02		###	#				
	3	A2_DCBUS_P3V	0x04		###	#				
	4	A2_DCBUS_P10V	0x08		###	#				
	5	A2_DCBUS_M10V	0x10		###	#				
	6	A2_DCBUS_TEMP	0x20		###	#				
A3	1	A3_DCBUS_GND	0x01		#	###				
	2	A3_DCBUS_N50V	0x02		#	###				
	3	A3_DCBUS_P50V	0x04		#	###				
	4	A3_DCBUS_N12V	0x08		#	###				
	5	A3_DCBUS_TEMP	0x10		#	###				
User	1	User Data	User Data Lost							###
	2	State Data	State Data Lost							###
	3	Correction Data	Corr Data Lost							###
	4	Scanner Correction Data	Scanner Data Lost							###
Battery	1	A1_DCBUS_BATTERY	Battery Low	###						

###: Most suspicious assembly

##: Suspicious assembly

#: Possible faulty assembly

Function Specific Troubleshooting

If the E4980A exhibits a failure symptom that is related to a specific function or control such as a front panel key control, display, data storage, remote control interface, external trigger, isolate the trouble using the Function Specific Troubleshooting procedures described below. The major functions of the E4980A and the troubleshooting procedure for each function are shown in Table 4-5.

Table 4-5 Major functions and troubleshooting procedures

Function	Description	Troubleshooting
Front panel keys	All the E4980A functions can be set and controlled via the front panel keys.	Refer to “To Check the Front Panel” on page 41.
LCD display	Almost all the information including the measurement value, setup state, result data processing, menu bar, softkey label and others are indicated on the LCD display.	Refer to “To Check the LCD” on page 41.
Front USB port	The USB port is used to save data in a USB memory. The LED for USB lights up while accessing the USB memory.	Refer to “To Check the Front USB port” on page 41.
External trigger input	The external trigger input terminal (BNC) on the rear panel allows an external trigger source to be used for measurement trigger.	Refer to “To Check the External Trigger Input” on page 42.
LAN port	The LAN interface port on the rear panel allows the E4980A to be connected to 10/100 Base-T Ethernet.	Refer to “To Check the LAN” on page 42.
GPIB Interface	The GPIB compatibility allows the E4980A to be operated as a talker/listener on IEEE 488 interface bus.	Refer to “To Check the GPIB” on page 44.
USB (USBTMC) Interface	Through this port, you can control the E4980A via external controllers. It is equivalent to control via GPIB.	Refer to in “To Check the USB (USBTMC) Interface Card” on page 45.
Handler interface (Option E4980A-201)	The interface is for data exchange with an automatic machine (handler) used on production line.	Refer to in “To Check the Handler Interface Function (Option 201 only)” on page 45.
Scanner interface (Option E4980A-301)	The interface to connect a scanner to perform up to 128 sets of multi-channel correction and measurements.	Refer to in “To Check the Scanner Interface Function (Option 301 only)” on page 49.
Bias current interface (Option E4980A-002)	The interface to connect the 42841A (Bias Current Source).	Refer to in “To Check the Bias Current Interface Function (Option 002 only)” on page 53.

To Check the Front Panel

Procedure

Randomly press the front panel keys to verify that they work normally.

- Step 1.** Press [System] - **SELF TEST**
- Step 2.** Use the cursor key to highlight the selection item to the right of “TEST No.”.
- Step 3.** Select **4 KEY** using the **INCR+** or **DECR-** softkey.
- Step 4.** Press **EXECUTE - TEST START**.
- Step 5.** Randomly press the front panel keys. The key name of the pressed key is displayed.
- Step 6.** To exit the front panel test, press **TEST STOP** three times consecutively, and then press [Return].
 - If multiple keys fail to work, a problem in key function (keypad, key flex circuit) or display interface board.
 - If only a specific key doesn't work, check first if the key is subsided in the panel.

To Check the LCD

Procedure

- Step 1.** Press [System] - **SELF TEST**
- Step 2.** Use the cursor key to highlight the selection item to the right of “TEST No.”.
- Step 3.** Select **5 DISPLAY** using the **INCR+** or **DECR-** softkey.
- Step 4.** Press **EXECUTE - TEST START**. The whole of the LCD screen turns Red, Green, Blue, Black, and White every 2 seconds.
- Step 5.** To exit the DISPLAY test, press **TEST STOP**, and then press [Return].
 - If the LCD display has a problem, check the LCD and the display interface board.
 - If the LCD is not illuminated with backlight, check the inverter board.

To Check the Front USB port

Procedure

- Step 1.** Plug a USB memory, formatted with FAT16 or FAT32.

NOTE

The following USB memory can be used.

Complies with USB 1.1; mass storage class, FAT16/FAT32 format; maximum consumption current is below 500 mA.

Recommended USB memory: Agilent 512 MB USB Flash memory (Agilent PN 1819-0195).

Use the prepared USB memory device exclusively for the E4980A; otherwise, other

Troubleshooting

Function Specific Troubleshooting

previously saved data may be cleared. If you use a USB memory other than the recommended device, data may not be saved or recalled normally.

- Step 2.** Press [Save/Recall].
- Step 3.** Use the cursor keys to select the MEDIA field.
- Step 4.** Press the **EXT** softkey.
- Step 5.** Use the cursor keys to select the No. 11.
- Step 6.** Press the **SAVE** softkey to save configuration states into the USB memory.
- Step 7.** Press [Save/Recall].
- Step 8.** Use the cursor keys to select the MEDIA field.
- Step 9.** Press the **EXT** softkey.
- Step 10.** Use the cursor keys to select the No. 11.
- Step 11.** Press the **RECALL** softkey to recall configurations from the USB memory.

If the file save or recall operation fails, a failure in the USB port or A1 board is suspected. Also check the cable between the USB port and A1 board.

To Check the External Trigger Input

Procedure

- Step 1.** Press [Preset] - **CLEAR SETTING - OK** to initialize the E4980A.
- Step 2.** Press [Meas Setup].
- Step 3.** Using the cursor keys, select the TRIG field, and then select **EXT** softkey.
- Step 4.** Press [Display Format].
- Step 5.** Connect a BNC Short or 50 Ω termination to the Ext Trig connector on the rear panel and disconnect it. Thereby a measurement trigger should be generated and a measurement result should be refreshed.
- Step 6.** If no trigger occurs, a failure in the A1 board is suspected.

To Check the LAN

Procedure

- Step 1.** Connect a LAN cable between the LAN port on the rear panel and an external computer (PC).

NOTE

Use a crossed LAN cable to enable the peer-to-peer communication between the E4980A and the PC. If the E4980A needs to be connected to the PC via a multi port Hub, use a straight LAN cable.

- Step 2.** Press [System].

- Step 3.** Press the **SYSTEM CONFIG** softkey.
- Step 4.** Select the DHCP ENABLED field using the cursor keys and then press the **OFF** softkey.
- Step 5.** Select the AUTO-IP ENABLED field using the cursor keys and then press the **OFF** softkey.
- Step 6.** Enter the following IP address and subnet mask using the enter keys. For selecting the MANUAL IP ADDR or MANUAL SUBNET MASK field, use the cursor keys.
- IP Address: 192.168.0.1
- Subnet Mask: 255.255.255.0
- Step 7.** Set up the IP address/subnet mask for the external PC.
- a. Double-click “**My Computer**” icon on Windows desktop of the external PC. And double-click **Control Panel**. The Control Panel window will appear.
 - b. In the Control Panel window, double-click **Network**. The Network dialog box will appear. In the **Configuration** tab, select **TCP/IP** (display it in revers video) and press the **Properties** button.
 - c. The dialog box appears. If **Specify an IP address** has been selected, record the IP address and subnet mask.
 - d. If the **Obtain an IP address automatically** has been selected, select the **Specify an IP address**. Enter the IP address xxx.xxx.xxx.y and subnet mask xxx.xxx.xxx.xxx as shown in Figure 4-6. The letters x represent the IP address and subnet mask of the E4980A. The letter y is different from the IP address of the E4980A. Press the **OK** button. Then, restart the external PC.

Figure 4-6 Network Dialog Box (“IP Address” Tab)

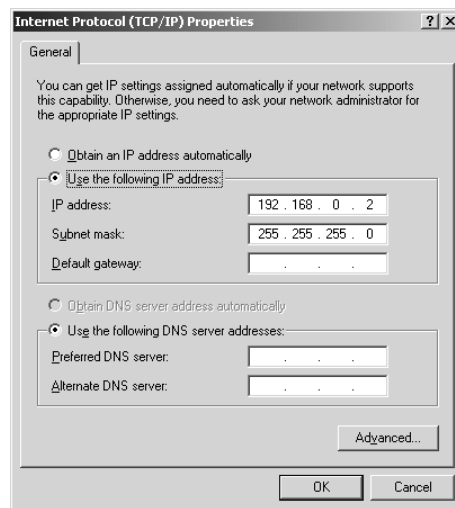

e4980ase1055

- Step 8.** By clicking “OK” button, the network settings take effect. Verify the E4980A LAN settings and response to a command from the external computer as follows:
- a. On the external computer, click "Start" button in the Windows Start menu bar using a mouse.

Troubleshooting

Function Specific Troubleshooting

- b. Click "Programs" and "MS-DOS Prompt" (or "Command Prompt") to open the DOS (Command) Prompt window.
- c. Type a ping command followed by the E4980A IP address as "ping xxx.xxx.xxx.xxx" (where, xxx.xxx.xxx.xxx is the IP address such as 192.168.0.1 assigned in step 3-d.) Press [Enter] key on the keyboard.
- d. The external computer displays a message of ping command response from the E4980A. Figure 4-7 shows an example of normal result that indicates the IP address, packet size, and a response time counted by the computer. The ping command is repeated 4 times.

Figure 4-7

Example of normal ping command test result

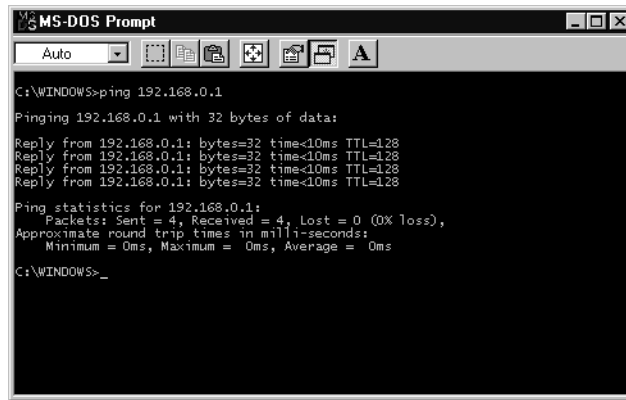

```
MS-DOS Prompt
Auto
C:\WINDOWS>ping 192.168.0.1
Pinging 192.168.0.1 with 32 bytes of data:
Reply from 192.168.0.1: bytes=32 time<10ms TTL=128
Reply from 192.168.0.1: bytes=32 time<10ms TTL=128
Reply from 192.168.0.1: bytes=32 time<10ms TTL=128
Reply from 192.168.0.1: bytes=32 time<10ms TTL=128
Ping statistics for 192.168.0.1:
    Packets: Sent = 4, Received = 4, Lost = 0 (0% loss),
    Approximate round trip times in milli-seconds:
        Minimum = 0ms, Maximum = 0ms, Average = 0ms
C:\WINDOWS>
```

If the E4980A doesn't return the response, the external computer displays a message of "Request timed out" as shown in Figure 4-8. In this case, a failure in the PPMC PCA is suspected.

Figure 4-8

Example of no response for ping command

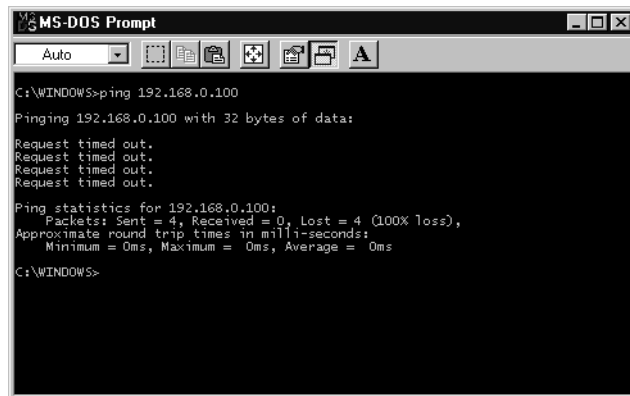

```
MS-DOS Prompt
Auto
C:\WINDOWS>ping 192.168.0.100
Pinging 192.168.0.100 with 32 bytes of data:
Request timed out.
Request timed out.
Request timed out.
Request timed out.
Ping statistics for 192.168.0.100:
    Packets: Sent = 4, Received = 0, Lost = 4 (100% loss),
    Approximate round trip times in milli-seconds:
        Minimum = 0ms, Maximum = 0ms, Average = 0ms
C:\WINDOWS>
```

To Check the GPIB

Procedure

Perform the E4980A performance test program. If the controller cannot detect the E4980A, the problem seems in the PPMC PCA or the connection of the GPIB cable.

To Check the USB (USBTMC) Interface Card

Procedure

Connect the USB cable between the controller PC and the E4980A. Turn the controller PC on. If the E4980A cannot detect the controller PC, the problem seems in the USB (USBTMC) Interface of the PPMC PCA is suspected.

To Check the Handler Interface Function (Option 201 only)

Perform this test only when troubleshooting the Option 201 Handler Interface Board. This test verifies the handler interface functions.

Equipment

Table 4-6

Equipment List of the Handler Interface Function Test (Option 201 only)

Handler Simulator	Agilent p/n 04278-65001
-------------------	-------------------------

Procedure

- Step 1.** Disconnect the power cable from the E4980A and allow 1 minute for the internal capacitors to discharge.

NOTE Dangerous energy/voltage exists when the E4980A is in operation, and for a time after it is powered down. Allow 1 minutes for the internal capacitors to discharge.

- Step 2.** Remove the Handler Interface Board according to the procedure for describing in “Handler Interface” Chapter of the User’s Guide.

NOTE The interface board contains electronic components that can be damaged by static electricity through electrostatic discharge (ESD). To prevent ESD damage, maintain frequent contact with any bare sheet metal surface on the chassis. A grounding wrist strap (or similar device) is useful for this purpose. Handle the board carefully at all times. Avoid touching electronic components or circuit paths.

NOTE Before performing Step 3, note the jumper and switch settings on the handler interface board in order to return them to the same settings at the end of this function test.

- Step 3.** Set the jumpers and switch on the handler interface board to the same settings as when the board is shipped from the factory. Refer to Figure 4-9, Table 4-7, and Table 4-8.

Figure 4-9

Jumper, and Switch Settings

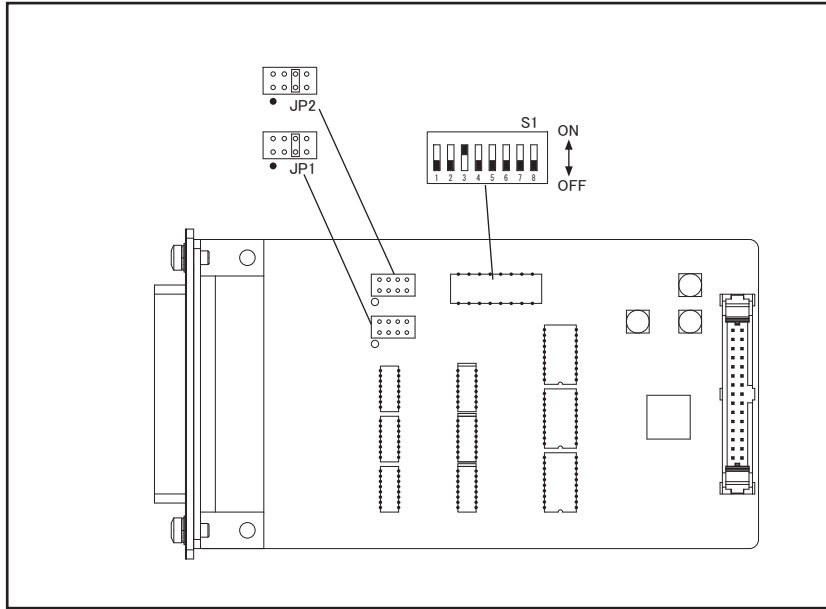

e4980ase1049

Table 4-7 Internal jumper settings

Jumper number	Jumper position *1
JP1	1
	2
	3(N)
	4
JP2	1
	2
	3(N)
	4

*1. The factory default setting is position (N) shown in the table above.

Table 4-8 Bit switch (S1) settings

Bit number *1	Factory default settings
1	Off
2	Off

Table 4-8 Bit switch (S1) settings

Bit number *1	Factory default settings
3	On
4	Off
5	Off
6	Off
7	N.A.
8	N.A.

*1. The bit numbers referenced in this table are the numbers printed on the bit switch (S1) of the handler interface board.

- Step 4.** Replace the handler interface board.
- Step 5.** Turn the E4980A ON.
- Step 6.** Connect the handler interface connector on the E4980A's rear panel to the handler simulator as shown in Figure 4-10.

Figure 4-10 Handler Interface Function Test Setup

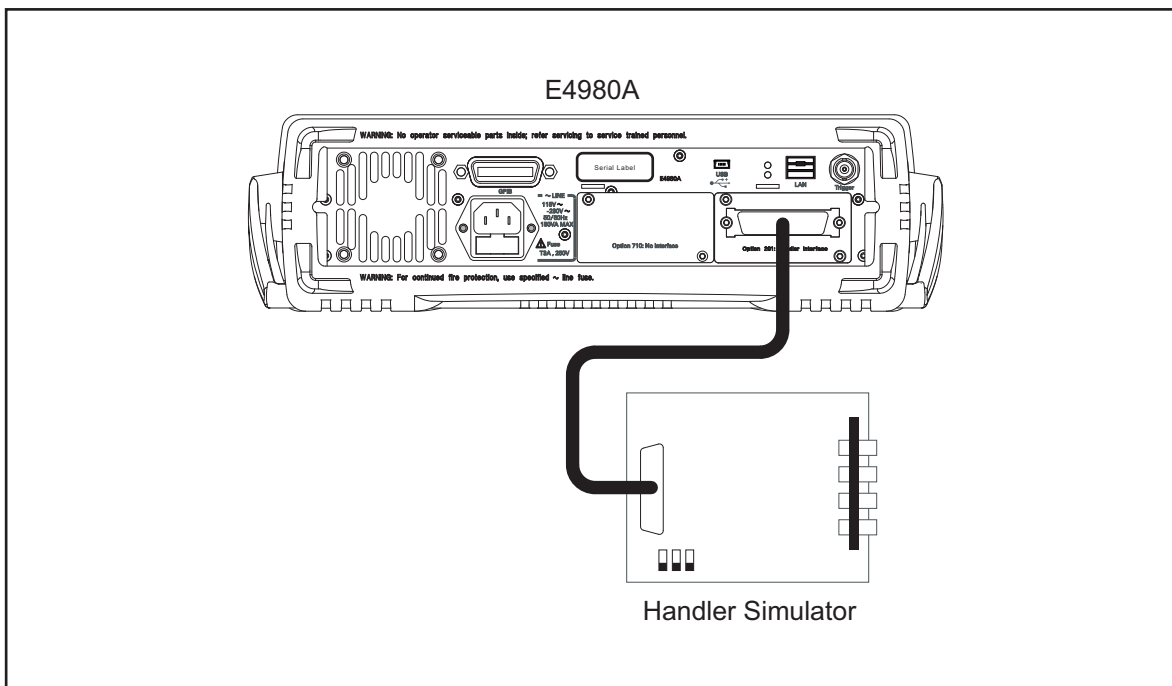

e4980ase1050

- Step 7.** Press [System].
- Step 8.** Press the **SELF TEST** softkey to display the **SELF TEST** page.

4. Troubleshooting

Troubleshooting
Function Specific Troubleshooting

Step 9. Use the **CURSOR** arrow keys to move the cursor to the **TEST MENU** field.

Step 10. Use the softkeys to select the **HANDLER INTERFACE** test.

Softkey	Function
INCR +	Increments the test number of the Test Menu.
DECR -	Decrements the test number of the Test Menu.

Step 11. Press the **EXECUTE - TEST START** softkeys to execute the **HANDLER INTERFACE** test.

Step 12. Confirm that the LEDs on the handler simulator turn ON in accordance with the E4980A's output signals displayed on the LCD. The LEDs turns ON light in the sequence shown in Figure 4-11.

Figure 4-11 Handler Interface Function Check

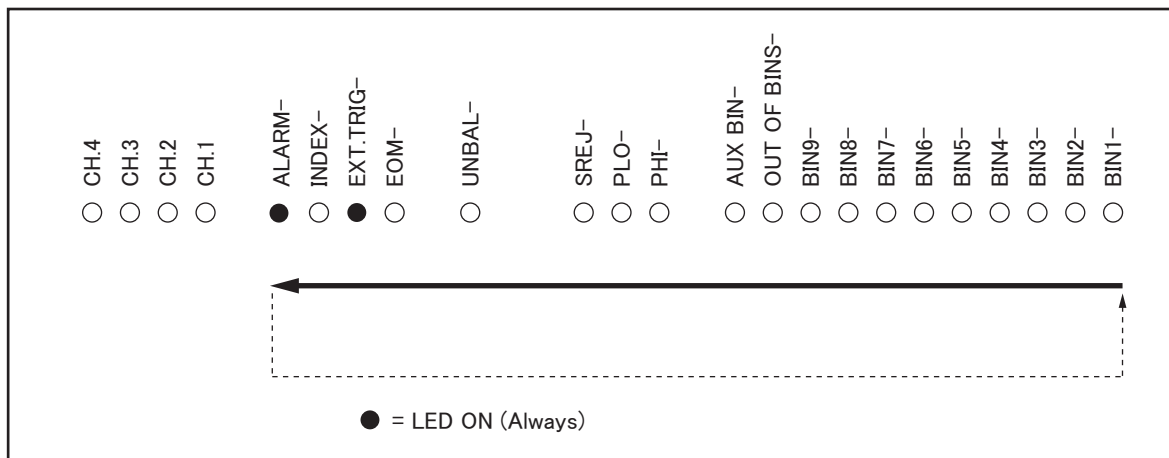

e4980ase1051

Step 13. Press the **TEST STOP** softkey.

NOTE Do not execute any SELF TEST except for the Handler Interface Test or the E4980A will become inoperative.

Step 14. Return the jumper and switch settings on the handler interface board to their original settings.

To Check the Scanner Interface Function (Option 301 only)

Perform this test only when troubleshooting the Option 301 scanner interface board. This test verifies the scanner interface function.

Equipment

Table 4-9

Equipment List of the Scanner Interface Function Test (Option 301 only)

Scanner Simulator	Agilent p/n 04278-65301
DC Power Supply	Agilent E3610A
1 k Ω Standard	Agilent 42030A (42037A)

Procedure

- Step 1.** Disconnect the power cable from the E4980A and allow 1 minute for the internal capacitors to discharge.

NOTE Dangerous energy/voltage exists when the E4980A is in operation, and for a time after it is powered down. Allow 1 minutes for the internal capacitors to discharge.

- Step 2.** Remove the Scanner Interface Board according to the procedure for describing in “Scanner Interface” Chapter of the User’s Guide.

NOTE The interface board contains electronic components that can be damaged by static electricity through electrostatic discharge (ESD). To prevent ESD damage, maintain frequent contact with any bare sheet metal surface on the chassis. A grounding wrist strap (or similar device) is useful for this purpose. Handle the board carefully at all times. Avoid touching electronic components or circuit paths.

NOTE Before performing Step 3, note the switch settings on the scanner interface board in order to return them to the same settings at the end of this function test.

- Step 3.** Set S1 and S2 on the scanner interface board to the same settings as when the board is shipped from the factory referring to Figure 4-12, Table 4-10, and Table 4-11.

Figure 4-12 Switches Setting

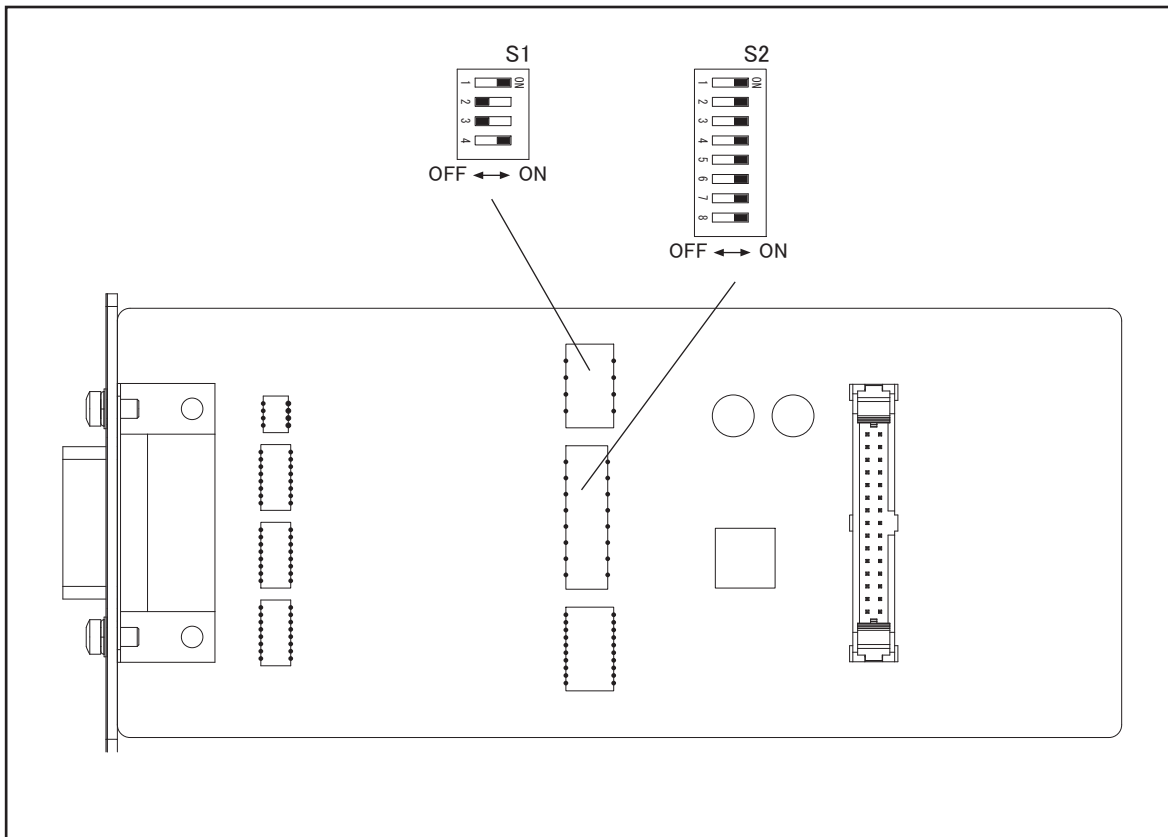

e4980ase1052

Table 4-10 Setting Bit Switch (S1)

Bit	Default
1*1	On
2*1	Off
3*1	Off
4	On

*1. For bits 1 to 3 of bit switch S1, only one bit can be turned on at one time.

Table 4-11 Setting Bit Switch (S2)

Bit	Default
1-8	On

NOTE Bit switches S1 and S2 can be identified by the labels “S1” and “S2” on the scanner

interface board.

- Step 4.** Replace the scanner interface board.
- Step 5.** Set DC power supply output voltage +5 V. Connect TP2 (GND) on the bias interface simulator to '-' terminal of the power supply. Then connect TP1 (Vcc) on the simulator to '+' terminal of the power supply. (Refer to Figure 4-13.)

Figure 4-13 Scanner Simulator Connections

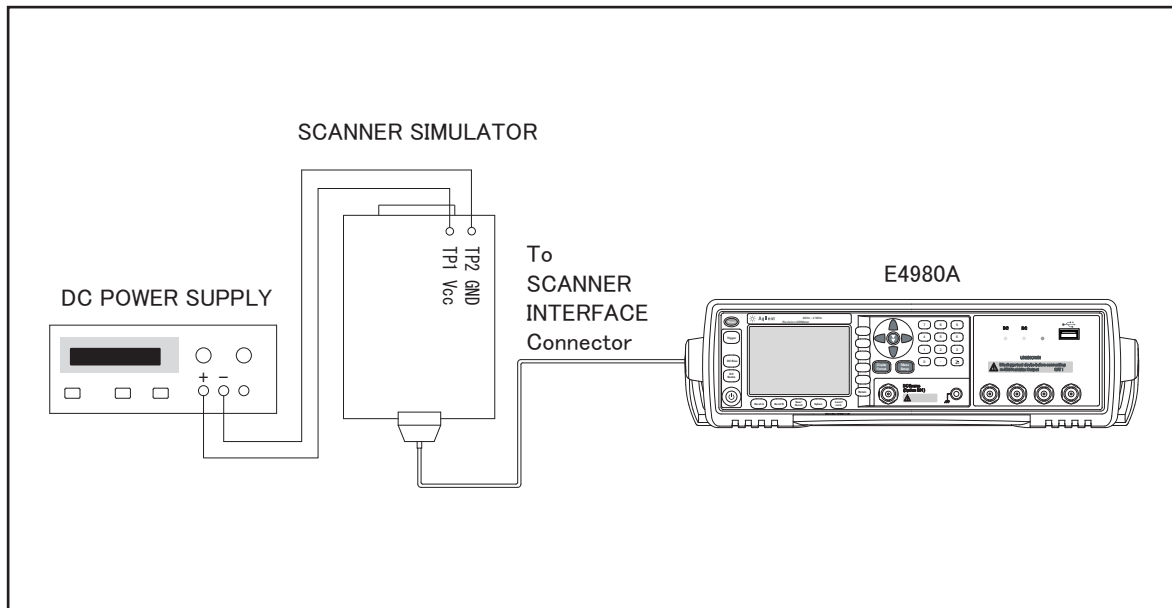

e4980ase1053

NOTE DC power for the bias interface simulator can be supplied from the E4980A instead of an external DC power supply.

- Step 6.** Connect the scanner simulator to the scanner interface connector on the E4980A's rear panel shown in Figure 4-13.
- Step 7.** Connect the 1 k Ω standard to the UNKNOWN terminal on the E4980A's front panel.
- Step 8.** Turn the E4980A ON.
- Step 9.** Press [System].
- Step 10.** Press the **SELF TEST** softkey to display the **SELF TEST** page.
- Step 11.** Use the **CURSOR** arrow keys to move the cursor to the **TEST MENU** field.
- Step 12.** Use the softkeys to select the **SCANNER INTERFACE** test.

Softkey	Function
INCR +	Increments the test number of the Test Menu.
DECR -	Decrements the test number of the Test Menu.

Troubleshooting
Function Specific Troubleshooting

Step 13. Press the **EXECUTE - TEST START** softkeys to execute the **SCANNER INTERFACE** test.

Step 14. Confirm that LEDs on the scanner simulator board turn ON in accordance with the E4980A settings displayed in the LCD.

Step 15. Press the **TEST STOP** softkey.

NOTE

Do not execute any SELF TEST except for the Scanner Interface Test or the E4980A will become inoperative.

Step 16. Return the switch settings on the scanner interface board to their original settings.

To Check the Bias Current Interface Function (Option 002 only)

This test verifies the bias current interface functions.

Equipment

Table 4-12

Equipment List of the Bias Current Interface Function Test (Option 002 only)

Bias Interface Simulator	Agilent p/n 42841-65001
Bias Interface Cable	Agilent p/n 42841-61640
DC Power Supply	Agilent E3610A
Adapter	Agilent p/n E4980-60102

Procedure

- Step 1.** Set all switches of S1 and S2 on the bias interface simulator to '1' as shown in Figure 4-14.

Figure 4-14 Bias Interface Simulator

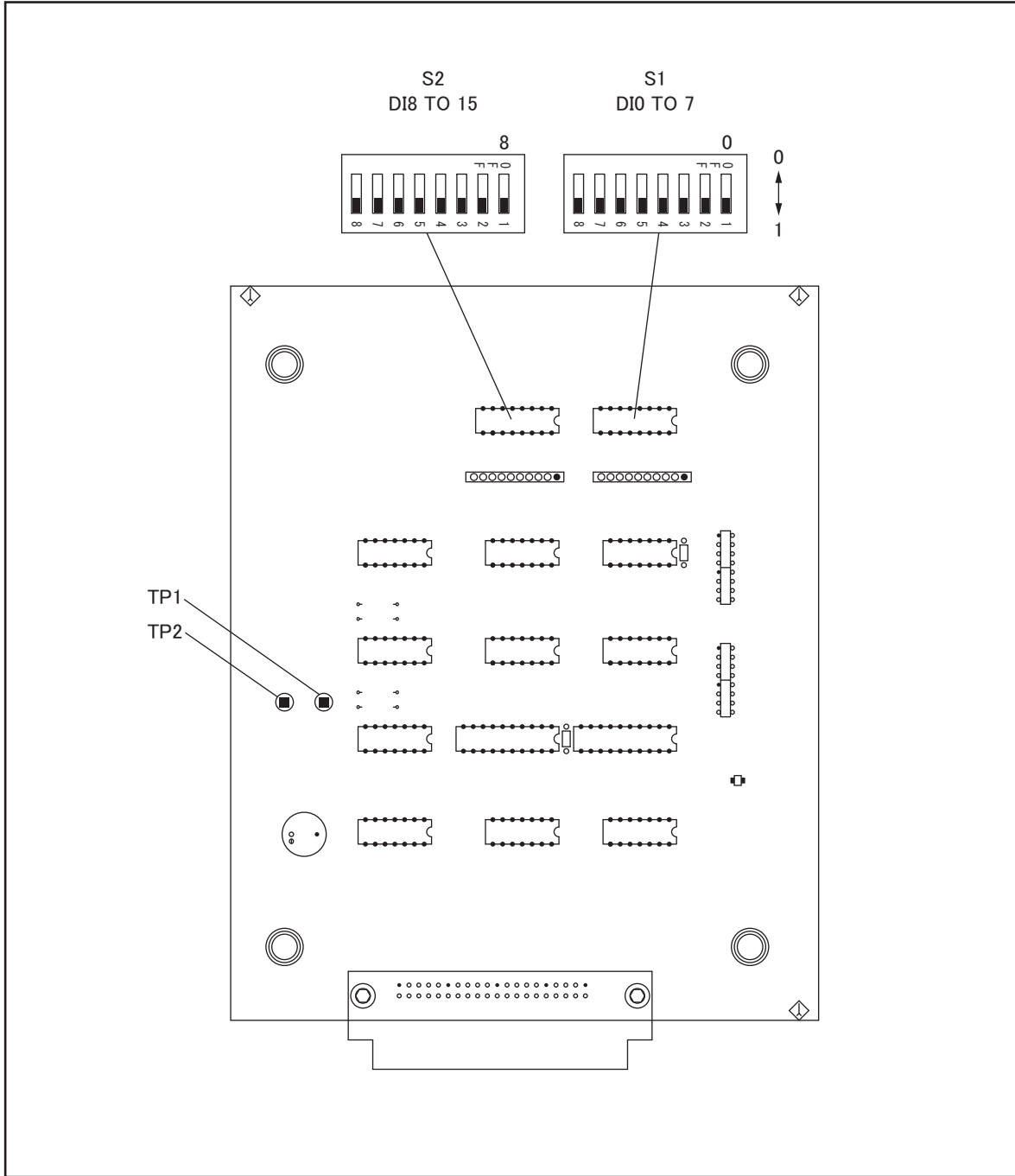

e4980ase1046

Step 2. Set DC power supply output voltage +5 V. Connect TP2 (GND) on the bias interface simulator to '-' terminal of the power supply. Then connect TP1 (Vcc) on the simulator to '+' terminal of the power supply. (refer to Figure Figure 4-14 and Figure 4-15.)

NOTE

DC power for the bias interface simulator can be supplied from the E4980A instead of from an external DC power supply.

Step 3. Interconnect the bias interface simulator and bias interface connector on the rear panel of the E4980A with the bias interface cable as shown in Figure 4-15.

NOTE Connect using the adapter between the bias interface connector on the rear panel of the E4980A and the bias interface cable, when you execute this step.

Figure 4-15 Bias Current Interface Function Test Setup

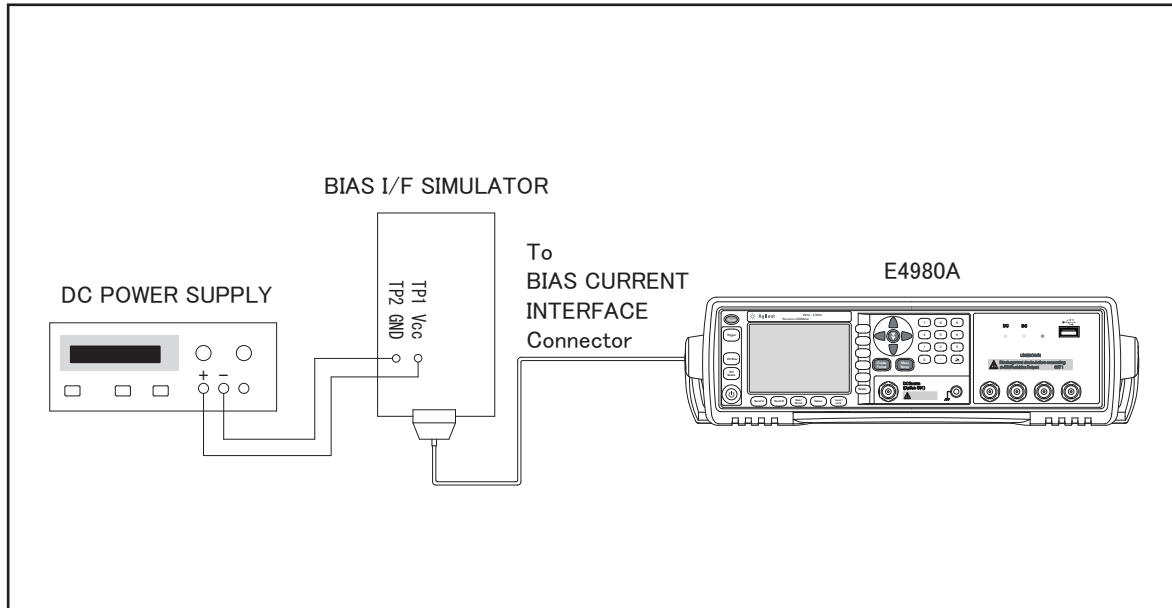

e4980ase1047

Step 4. Turn the E4980A ON.

Step 5. Press [System].

Step 6. Press the **SELF TEST** softkey to display the **SELF TEST** page.

Step 7. Use the **CURSOR** arrow keys to move the cursor to the **TEST MENU** field.

Step 8. Use the softkeys to select the **BIAS INTERFACE** test.

Softkey	Function
INCR +	Increments the test number of the Test Menu.
DECR -	Decrements the test number of the Test Menu.

Step 9. Press the **EXECUTE - TEST START** softkeys to execute the **BIAS INTERFACE** test.

NOTE Check the settings of S1 and S2 described in the Step 1, if the E4980A's LCD displays "Illegal Test Setup".

Step 10. Confirm the /RESET LED on the bias interface simulator turns ON.

Step 11. Confirm CS0 and CS1 LEDs on the simulator turns ON as the E4980A's output signal is

Troubleshooting
Function Specific Troubleshooting

displayed on the LCD (Refer to Figure 4-16).

- Step 12.** Confirm that ADRS1-ADRS6 LEDs on the simulator turn ON in accordance with the hexadecimal number displayed on the LCD. One of the 6 LEDs turns ON in sequence as shown in Figure 4-16.
- Step 13.** Confirm that DO0-DO7 LEDs on the simulator turn ON in accordance with the hexadecimal number displayed on the LCD. One of the 8 LEDs turns ON in sequence as shown in Figure 4-16.

Figure 4-16 Bias Current Interface Function Test

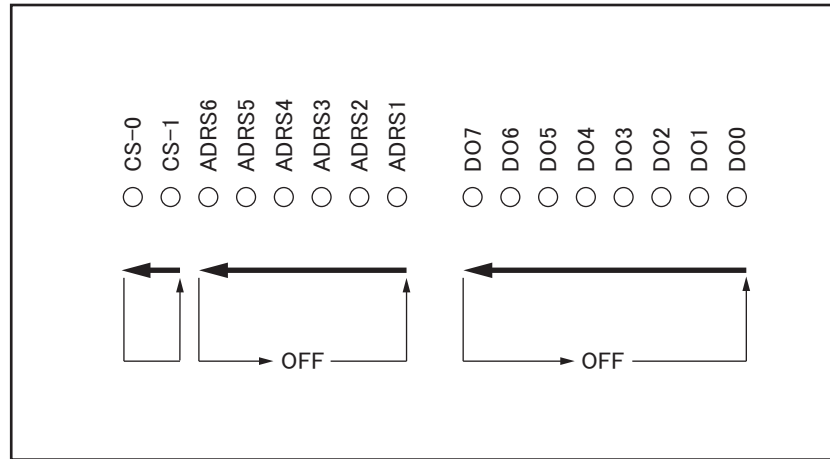

e4980ase1048

- Step 14.** Confirm that “DI0 TO 7” and “DI8 TO 15” on the LCD of the E4980A display hexadecimal number “ff”.
- Step 15.** Set switches S1 and S2 on the bias interface simulator to ‘0’. Then confirm that hexadecimal number “0” is displayed by “DI0 TO 7” and “DI8 TO 15”.

NOTE The states of S1 (DI0 TO 7) and S2 (DI8 TO 15) are displayed as a hexadecimal number on the E4980A’s LCD.

- Step 16.** Press the **TEST STOP** softkey.

NOTE Do not execute any SELF TEST except for the Bias Interface Test or the E4980A will become inoperative.

Performance test failure troubleshooting

This section describes the adjustment and troubleshooting procedures used when the E4980A fails the performance tests. If the performance of the instrument is critical for the test limits and seems to be adjustable, perform first the adjustment(s) related to the failed test. When the test result is far from the tolerance of the test or the performance is not adjustable, isolate the faulty assembly in accordance with the "Performance tests failure troubleshooting procedure".

Recommended adjustment for performance test failure

Table 4-13 shows the recommended adjustments when the performance test fails. Select the adjustment program corresponding to the recommended adjustment and perform the adjustment.

Table 4-13 Recommended adjustment for performance test failure

Test Num.	First failed test	Recommended adjustment			
		A1	A2	A3	PPMC
1	Frequency Accuracy Test			√	
2	DC Source Level Accuracy Test			√	
3	DC Bias Level Accuracy Test			√	
4	DC Bias V Level Monitor Accuracy Test		√		
5	DC Bias I Level Monitor Accuracy Test		√		
6	AC Signal Level Monitor Accuracy Test		√		
7	AC Signal Level Accuracy Test			√	
8	Impedance Measurement Accuracy Test		√		
9	DCR Measurement Accuracy Test		√		

Adjustment failure troubleshooting

Table 4-14 represents the relationships between the failed adjustment and probably faulty assembly. Note that this table lists some typical cases. There are possibilities that another assembly may be faulty.

Table 4-14 Adjustment failure troubleshooting information

Adj Num.	First failed adjustment	Probable faulty board assembly			
		A1	A2	A3	PPMC
1	Null DC offset adjustment		###		
2	Null ADC offset adjustment		###		
3	ADC Linearity adjustment		###	##	
4	DC Bias adjustment		##	###	
5	DC Level V Monitor adjustment		###		
6	DC Level I Monitor adjustment		###		
7	DC Source adjustment		#	###	
8	DCR adjustment		###	#	
9	Impedance adjustment		###	#	
10	AC level Monitor adjustment		###	#	
11	OSC Level adjustment		#	###	

###: Most suspicious assembly

##: Suspicious assembly

#: Possible faulty assembly

Performance test failure troubleshooting

Table 4-15 represents the relationships between the failed test and probable faulty assembly. If the performance test failure cannot be removed by a proper adjustment, replace the assembly shown in this table.

Note that this table lists some typical cases. There are possibilities that another assembly may be faulty.

Table 4-15 Performance test failure troubleshooting information

Test Num.	First failed test	Probable faulty board assembly			
		A1	A2	A3	PPMC
1	Frequency Accuracy Test		#	###	
2	DC Source Level Accuracy Test		#	###	
3	DC Bias Level Accuracy Test		#	###	
4	DC Bias V Level Monitor Accuracy Test		###		
5	DC Bias I Level Monitor Accuracy Test		###		
6	AC Signal Level Monitor Accuracy Test		###	#	
7	AC Signal Level Accuracy Test		#	###	
8	Impedance Measurement Accuracy Test		###	#	
9	DCR Measurement Accuracy Test		###	#	

###: Most suspicious assembly

##: Suspicious assembly

#: Possible faulty assembly

Troubleshooting

Performance test failure troubleshooting

5 **Replaceable Parts**

This chapter contains information for ordering replacement parts for the E4980A.

Ordering Information

To order a part in the replaceable parts lists, quote the Agilent Technologies part number, indicate the quantity required, and address the order to the nearest Agilent Technologies Sales Office.

To order a part not listed in the replaceable parts lists, include the instrument model number, the description and function of the part, and the quantity of parts required. Address the order to the nearest Agilent Technologies Sales Office.

Direct Mail Order System

Within the USA, Agilent Technologies can supply parts through a direct mail order system. There are several advantages to this system:

- Direct ordering and shipping from the Agilent Technologies parts center in California, USA.
- No maximum or minimum on any mail order. (There is a minimum amount for parts ordered through a local Agilent Technologies Sales Office when the orders require billing and invoicing.)
- Prepaid transportation. (There is a small handling charge for each order.)
- No invoices.

In order for Agilent Technologies to provide these advantages, please send a check or money order with each order.

Mail order forms and specific ordering information are available through your local Agilent Technologies Sales Office. Addresses and telephone numbers are located in a separate document shipped with the manuals.

Exchange Assemblies







Under the rebuilt-exchange assembly program, certain factory-repaired and tested assemblies are available on a trade-in basis. These assemblies are offered at lower cost than a new assembly, but meet all factory specifications required of a new assembly.

The defective assembly must be returned for credit under the terms of the rebuilt-exchange assembly program. Any spare assembly stock desired should be ordered using the new assembly part number.

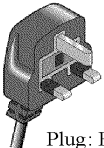
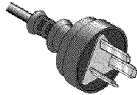
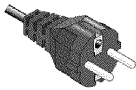
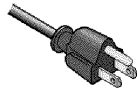
Replaceable Parts List

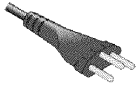
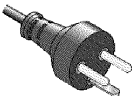
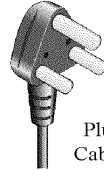
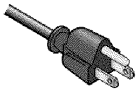
Power Cables and Plug Configurations

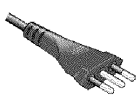
Figure 5-1 Power Cables and Plug Configurations

<p>OPTION 900</p>  <p>United Kingdom</p> <p>Plug: BS 1363/A, 250V, 10A Cable: 8120-1351, 8120-8705</p>	<p>OPTION 901</p>  <p>Australia/New Zealand</p> <p>Plug: AS 3112, 250V, 10A Cable: 8120-1369</p>
<p>OPTION 902</p>  <p>Continental Europe</p> <p>Plug: CEE 7 Standard Sheet VII, 250V, 10A Cable: 8120-1689</p>	<p>OPTION 903</p>  <p>U.S./Canada</p> <p>Plug: NEMA 5-15P, 125V, 10A Cable: 8120-1378</p>
<p>OPTION 904</p>  <p>U.S./Canada</p> <p>Plug: NEMA 6-15P, 250V, 6A Cable: 8120-0698</p>	<p>OPTION 906</p>  <p>Switzerland</p> <p>Plug: SEV Type 12, 250V, 10A Cable: 8120-2104</p>
<p>OPTION 912</p>  <p>Denmark</p> <p>Plug: SR 107-2-D, 250V, 10A Cable: 8120-2956</p>	<p>OPTION 917</p>  <p>India/Republic of S. Africa</p> <p>Plug: IEC 83-B1, 250V, 10A Cable: 8120-4211</p>
<p>OPTION 918</p>  <p>Japan</p> <p>Plug: JIS C 8303, 125V, 12A Cable: 8120-4753</p>	<p>OPTION 920</p>  <p>Argentina</p> <p>Plug: Argentine Resolution 63, Annex IV, 250V, 10A Cable: 8120-6870</p>
<p>OPTION 921</p>  <p>Chile</p> <p>Plug: CEI 23-16, 250V, 10A Cable: 8120-6978</p>	<p>OPTION 922</p>  <p>China</p> <p>Plug: GB 1002, 250V, 10A Cable: 8120-8376</p>
<p>NOTE: Each option number includes a 'family' of cords and connectors of various materials and plug body configurations (straight, 90° etc.).</p>	

power_e

Top View (Major Assemblies)

Figure 5-2 Top View (Major Assemblies)

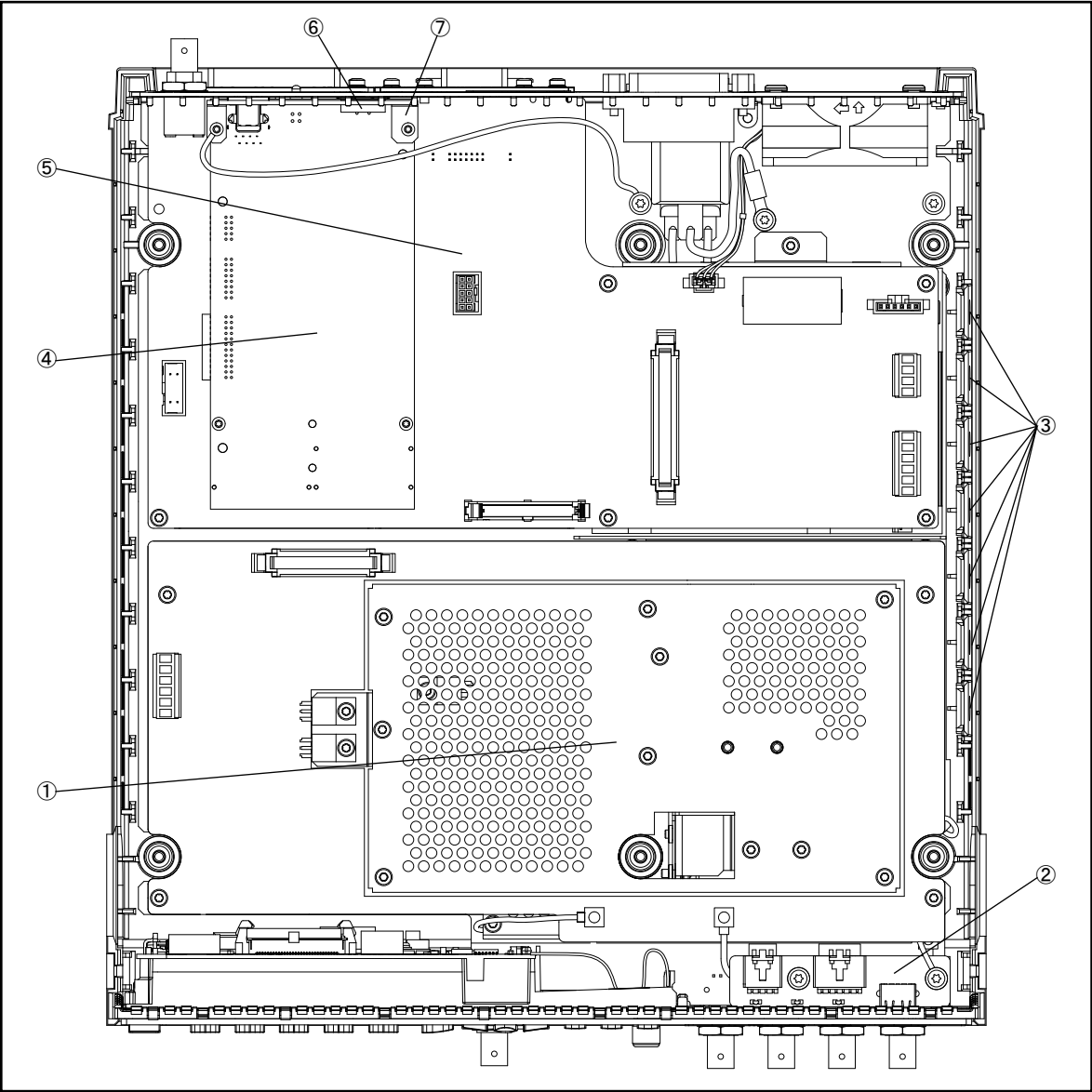

e4980ase1001

Table 5-1 Top View (Major Assemblies)

Ref. Desig.	Agilent Part Number	Qty.	Description
1	E4980-62003	1	TESTED PCA A3 (ANALOG DAUGHTER BOARD)
	E4980-69003	1	RSTRD E4980-62003 ANALOG
	0403-0424	2	BUMPER FOOT-ADH MTG 20.5-MM-WD (not included A3)
2	E4980-66509	1	PCA E4980 USB
3	5041-7724	7	VENT BLOCKS
4	E4980-62004	1	P1001 INSTALLED OS
5	E4980-66501	1	PCA E4980 MOTHER BOARD (A1)
6	E4980-07004	1	USB GASKET
7	E4980-01207	1	ANGLE CPU

Top View (Cables)

Figure 5-3 Top View (Cables)

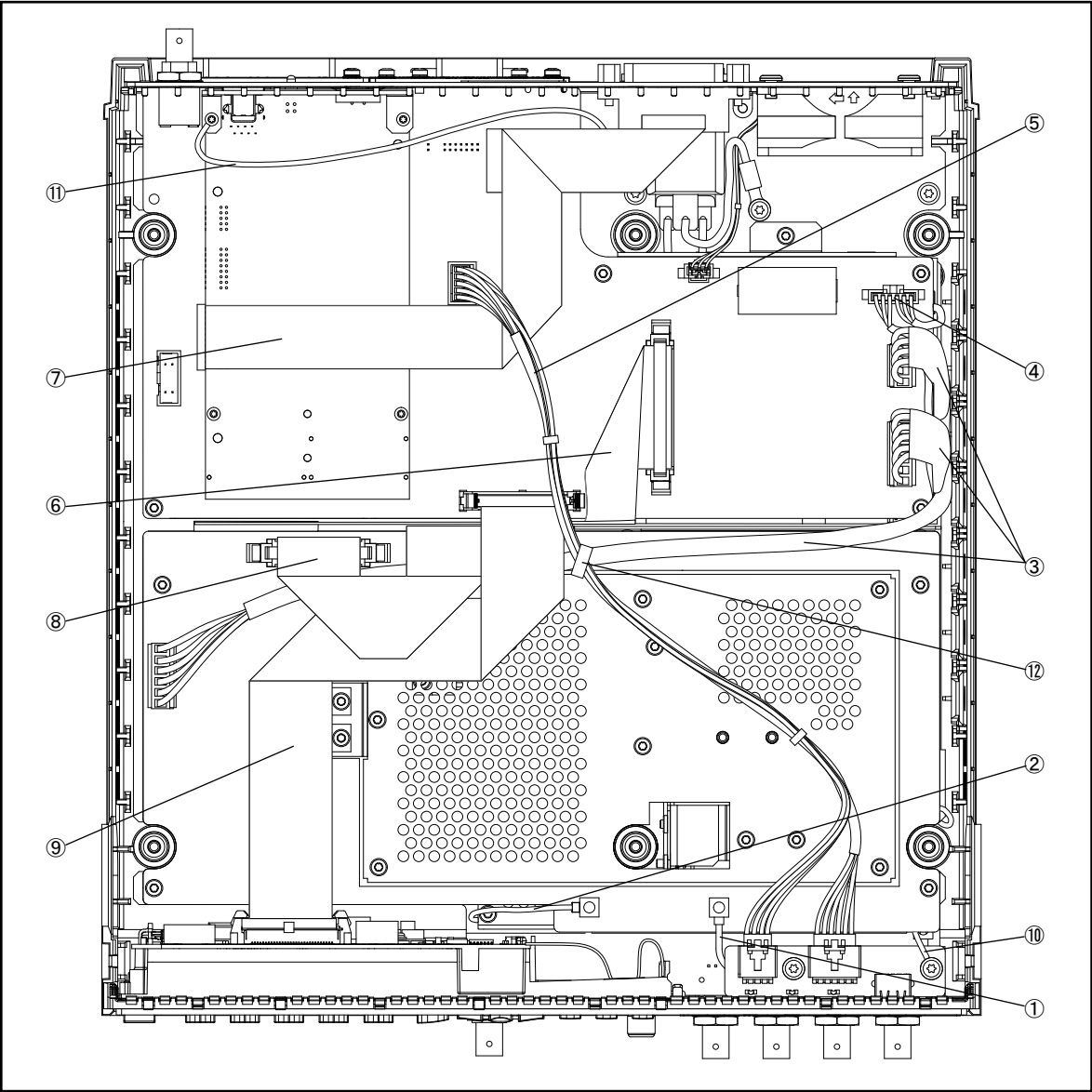

e4980ase1002

Table 5-2 Top View (Cables)

Ref. Desig.	Agilent Part Number	Qty.	Description
1	5188-1252	1	RF CABLE ASSY
2	5188-1254	1	RF CABLE ASSY
3	E4980-61601	1	POWER CABLE ASSY
4	E4980-61615	1	CABLE POWER CONTROL
5	E4980-61605	1	FRONT USB CABLE
6	E4980-61609	1	MOTHER-ANALOG CABLE ASSY
7	E4980-61610	1	GPIB CABLE ASSY
8	E4980-61602	1	ANALOG SOURCE CABLE ASSY
9	E4980-61603	1	LCD CABLE ASSY
10	E4980-61617	1	FRONT GND CABLE
11	E4980-61616	1	LAN GND CABLE
12	1400-0249	1	CABLE TIE .062-.625-DIA .091-WD NYL

Top View (Miscellaneous Parts)

Figure 5-4 Top View (Miscellaneous Parts)

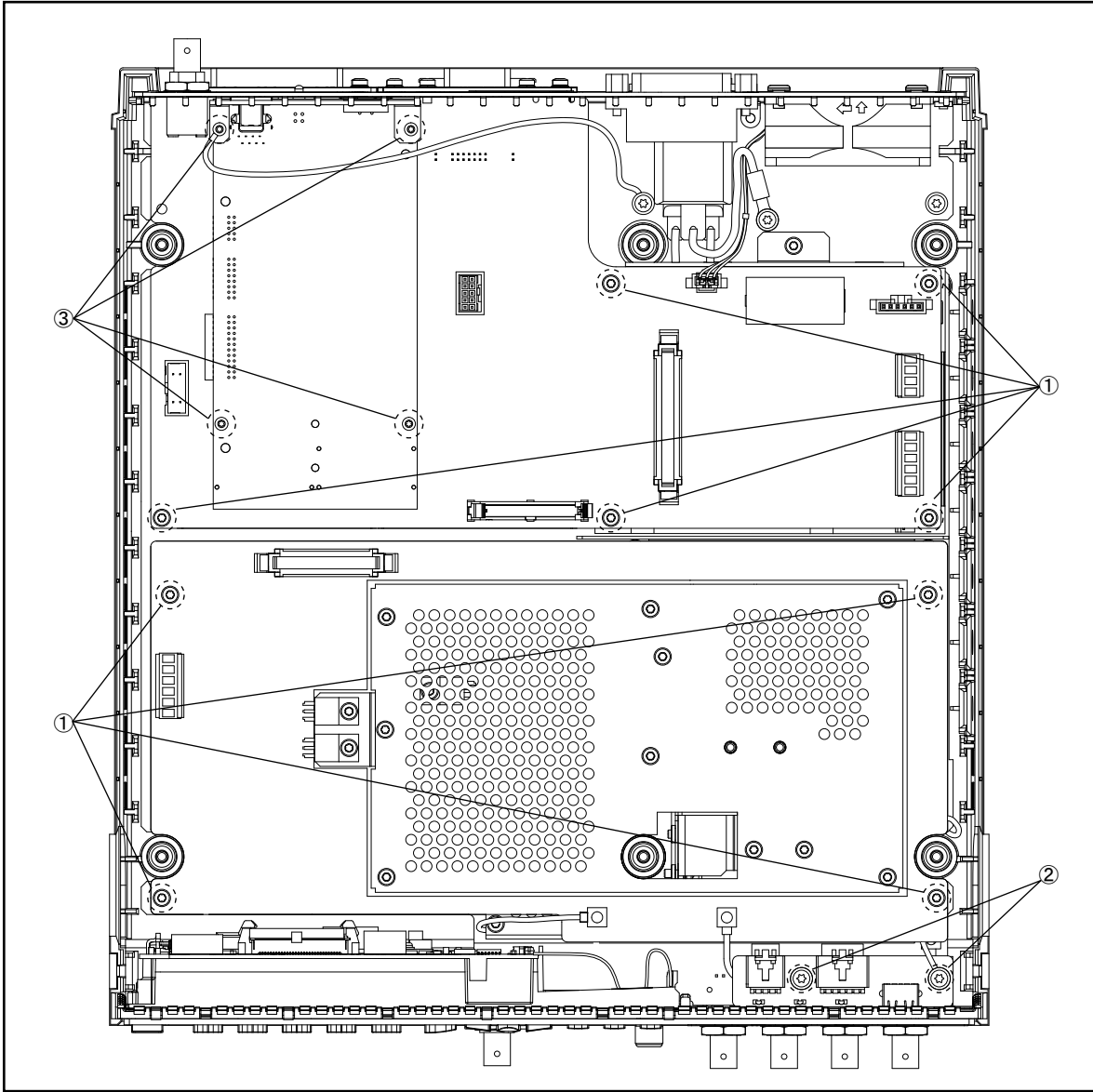

e4980ase1003

Table 5-3 Top View (Miscellaneous Parts)

Ref. Desig.	Agilent Part Number	Qty.	Description
1	0515-0430	9	SCREW-MACH M3 X 0.5
2	0515-4830	2	SCREW-MACH M4 X 0.7
3	0515-1940	4	SCREW-MACH M2.5 X 0.45

Top View (Tested PCA A2 (Analog Board))

Figure 5-5 Top View (Tested PCA A2 (Analog Board))

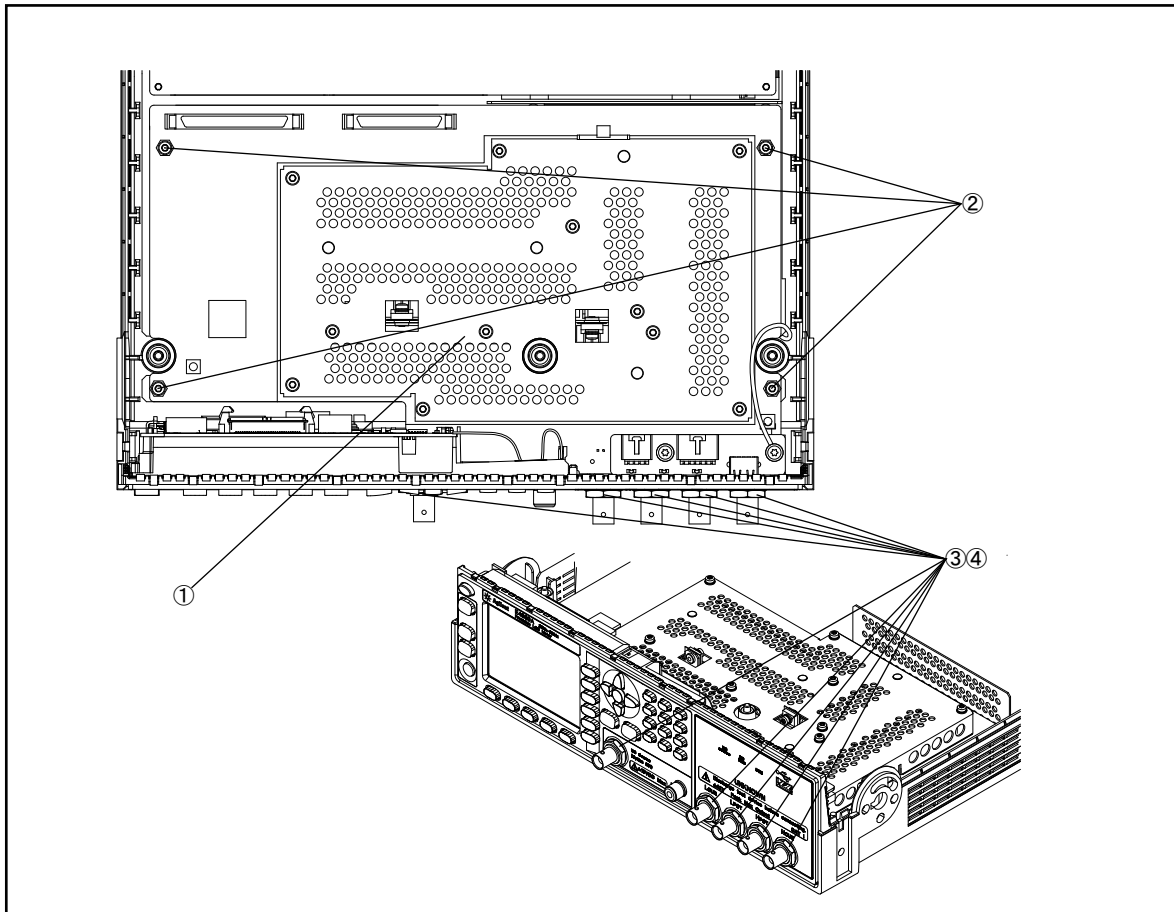

e4980ase1004

Table 5-4 Top View (Tested PCA A2 (Analog Board))

Ref. Desig.	Agilent Part Number	Qty.	Description
1	E4980-62002	1	TESTED PCA A2 (ANALOG BOARD)
	E4980-69002	1	RSTRD E4980-62002 ANALOG
2	0380-4989	4	STANDOFF-HEX M4X0.7
3	2940-0256	5	NUT-HEX-DBL-CHAM 1/2-28-THD .095-IN-THK
4	3050-2230	5	WASHER-SPR-WAVY 13-MM-ID 17-MM-OD

Front Panel

Figure 5-6 Front Panel

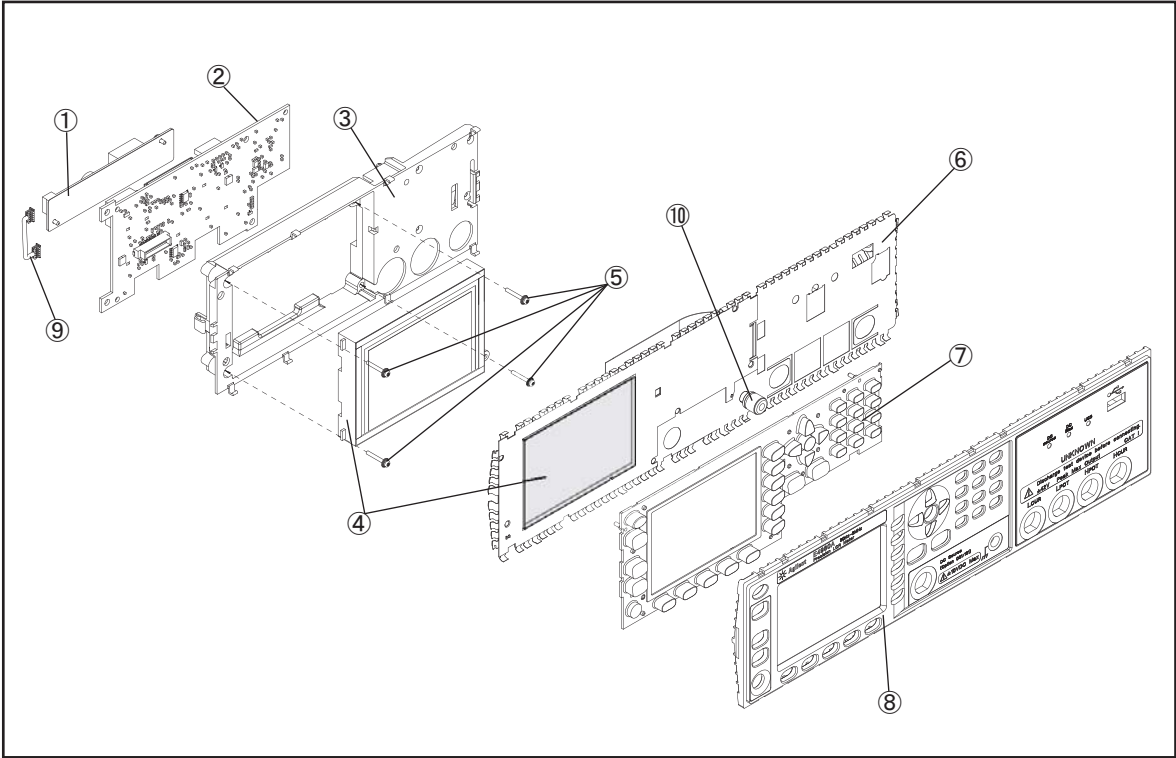

e4980ase1013

Table 5-5 Front Panel

Ref. Desig.	Agilent Part Number	Qty.	Description
1	E4980-25001	1	INSULATOR
	0950-4111	1	INVERTER
	0515-0365	2	SCREW-MACHINE M2 X 0.4
2	N1912-60002	1	DISPLAY INTERFACE
3	N1912-40002	1	DISPLAY SUPPORT
4	2090-0825	1	DISPLAY
	E4980-25003	2	LCD GASKET SHORT
	E4980-25004	2	LCD GASKET LONG
	N1912-20005	1	WINDOW,EMI SHIELD
5	0515-0661	4	SCREW-MACHINE ASSEMBLY M2 X 0.4 14MM-LG
6	E4980-07001	1	EMI SHIELD
	N1912-20001	1	KEY FLEX CIRCUIT
7	E4980-40012	1	KEYPAD
8	E4980-40001	1	FRONT PANEL
9	N1912-61002	1	CABLE ASSY BACKLIGHT
10	1510-0130	1	BINDING POST SGL
	3050-2229	1	WASHER-SPR-WAVY 6.4-MM-ID
	2950-0006	1	NUT-HEX-DBL-CHAM 1/4-32-THD

NOTE

Part numbers E4980-07002, N1912-20001 and E4980-40012 can be combined as a single sub-assembly under part number E4980-62005.

Table 5-6 E4980-62005 Sub-Assembly

Ref. Desig.	Agilent Part Number	Qty.	Description
1	E4980-25001	1	INSULATOR
	0950-4111	1	INVERTER
	0515-0658	2	SCREW-MACHINE M2 X 0.4
2	N1912-60002	1	DISPLAY INTERFACE
3	N1912-40002	1	DISPLAY SUPPORT
4	2090-0825	1	DISPLAY
	E4980-25003	2	LCD GASKET SHORT
	E4980-25004	2	LCD GASKET LONG

Replaceable Parts
 Replaceable Parts List

Table 5-6 E4980-62005 Sub-Assembly

Ref. Desig.	Agilent Part Number	Qty.	Description
	N1912-20005	1	WINDOW, EMI SHIELD
5	0515-0661	4	SCREW-MACHINE M2 X 0.4
6	E4980-07001	1	EMI SHIELD
	N1912-20001	1	KEY FLEX CIRCUIT
7	E4980-40012	1	KEYPAD
8	E4980-40001	1	FRONT PANEL
9	N1912-61002	1	CABLE ASSY BACKLIGHT
10	1510-0130	1	BINDING POST SGL
	3050-2229	1	WASHER-SPR-WAVY 6.4-MM-ID
	2950-0006	1	NUT-HEX-DBL-CHAM 1/4-32-THD
11	0515-4830	2	SCREW-MACHINE M4 X 0.7
12	E4980-66509	1	PCA E4980 USB BD
13	E4980-87001	1	NAME LABEL
14	E4980-87002	1	BNC LABEL
15	E4980-87003	1	GND LABEL

Top View (Power Supply Assembly)

Figure 5-7 Top View (Power Supply Assembly)

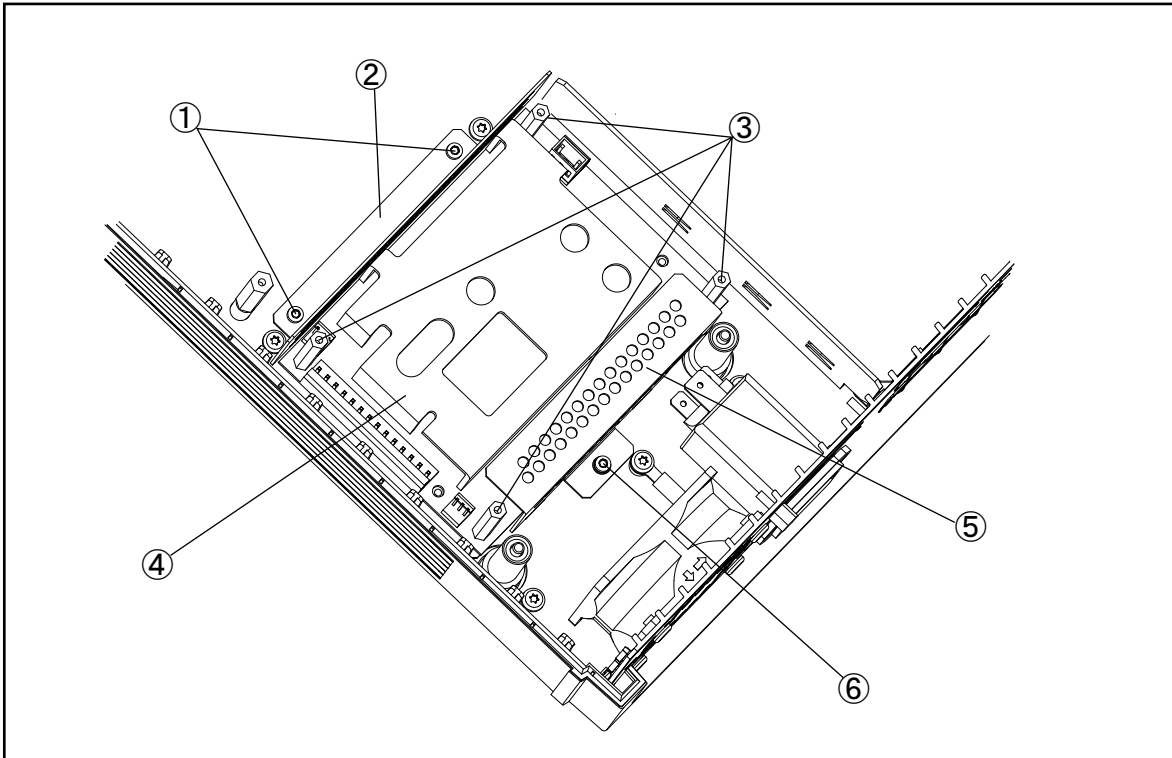

e4980ase1005

Replaceable Parts
Replaceable Parts List

Table 5-7 **Top View (Power Supply Assembly)**

Ref. Desig.	Agilent Part Number	Qty.	Description
1	0515-0430	2	SCREW-MACHINE M3 X 0.5
2	E4980-01205	1	ANGLE SHIELD
3	0380-4972	4	STANDOFF-HEX M3.0 X 0.5
4	E4980-60103	1	POWER SUPPLY
5	E4980-04001	1	PSU COVER
6	0515-0430	1	SCREW-MACHINE M3 X 0.5

Top View (Base Plate Assembly)

Figure 5-8 Top View (Base Plate Assembly)

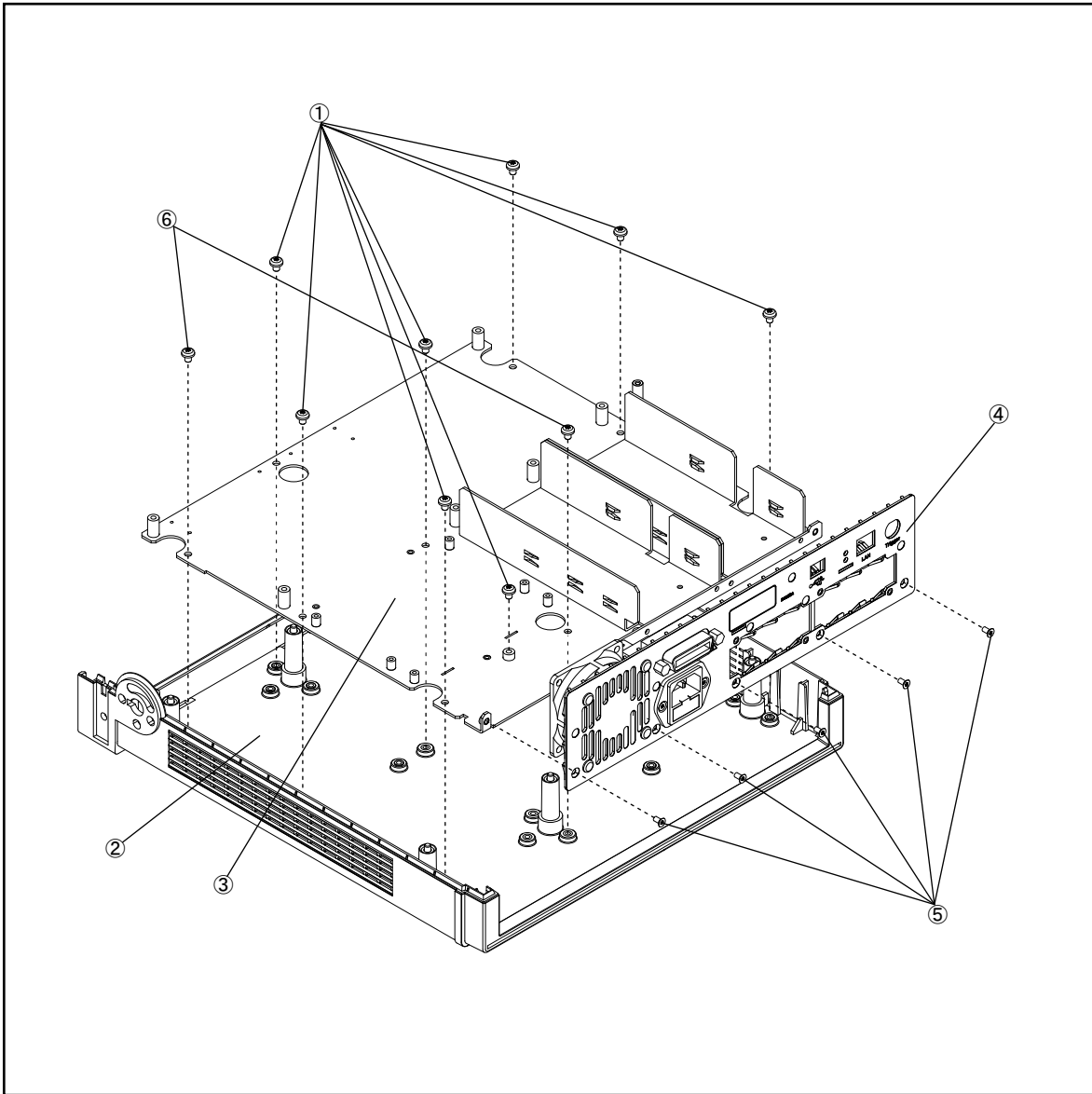

e4980ase1006

Replaceable Parts
Replaceable Parts List

Table 5-8 **Top View (Base Plate Assembly)**

Ref. Desig.	Agilent Part Number	Qty.	Description
1	0515-4830	8	SCREW-MACH M4 X 0.7
2	E4980-40003	1	3/4 RACK MODULE BOTTOM CASE
3	E4980-00111	1	BASE PLATE
4	See Table 5-10	1	REAR PANEL ASSEMBLY
5	0515-1946	5	SCREW-MACH M3 X 0.5
6	0515-2143	2	SCREW-MACH M4 X 0.7 6MM-LG PAN-HD

Gasket

Figure 5-9

Gasket

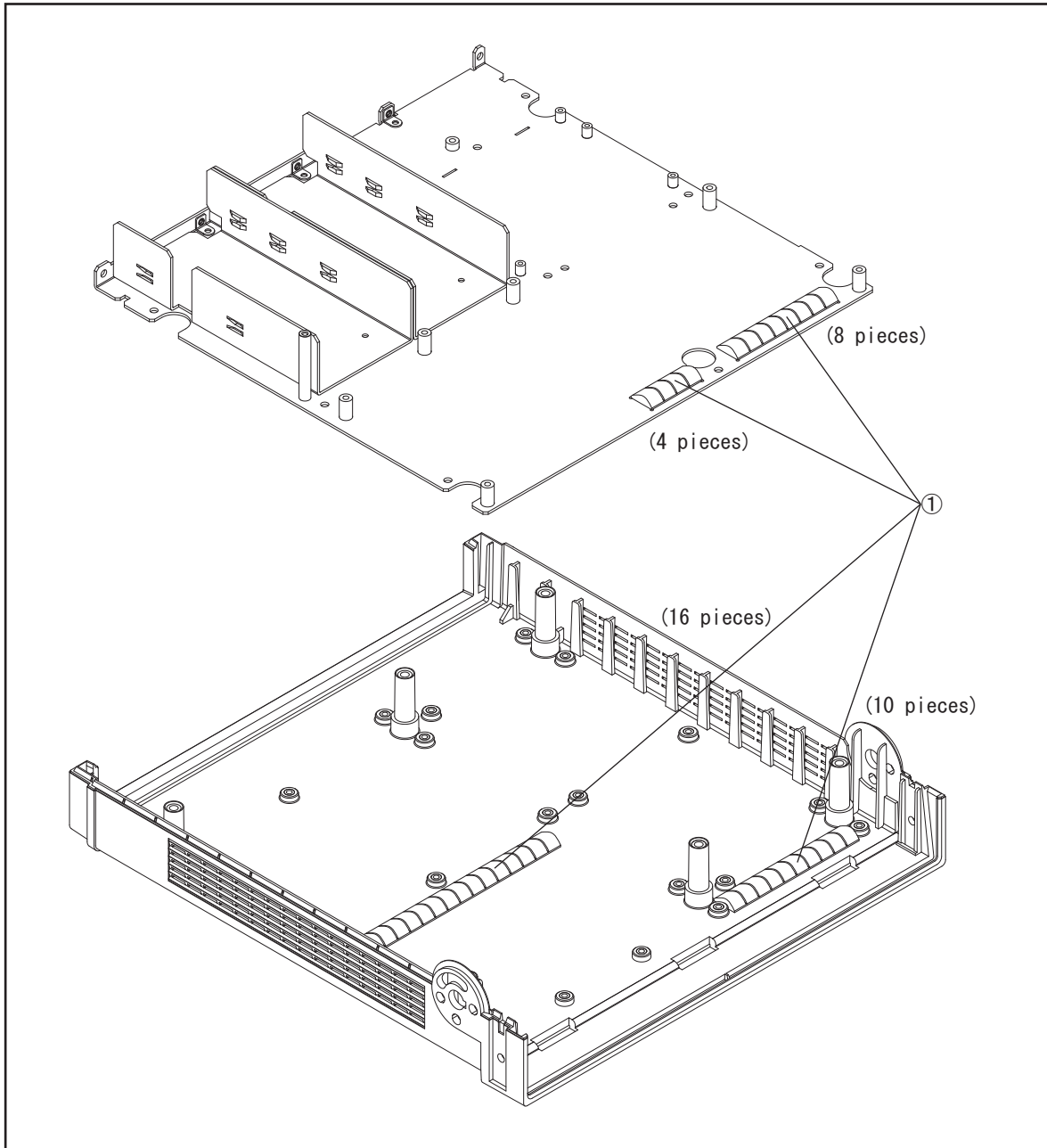

e4980ase1031

Table 5-9

Gasket

Ref. Desig.	Agilent Part Number	Qty.	Description
1	8160-0538	0.85	GASKET

Rear View

Figure 5-10 Rear View

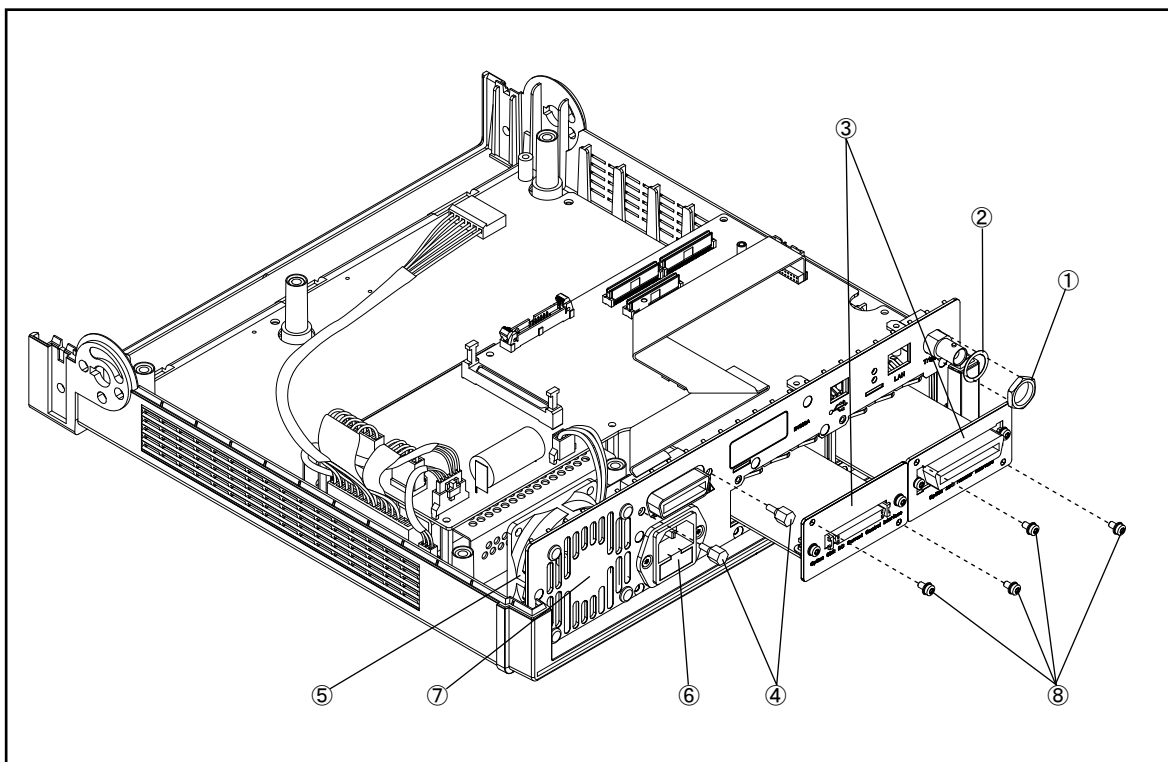

e4980ase1007

Table 5-10 Rear View

Ref. Desig.	Agilent Part Number	Qty.	Description
1	2940-0256	1	NUT-HEX-DBL-CHAM 1/2-28-THD .095-IN-THK
2	3050-2230	1	WASHER-SPR-WAVY 13-MM-ID 17-MM-OD
3	See Table 5-13	2	INTERFACE OPTION ASSEMBLY
4	0380-4870	2	STANDOFF-HEX .591-INCH-LG 4-40-THD
5	See Table 5-12	1	FAN ASSEMBLY
6	See Table 5-11	1	POWER INLET ASSEMBLY
7	E4980-00201	1	REAR PANEL
8	0515-0430	4	SCREW-MACHINE M3 X 0.5

Power Inlet Assembly

Figure 5-11 Power Inlet Assembly

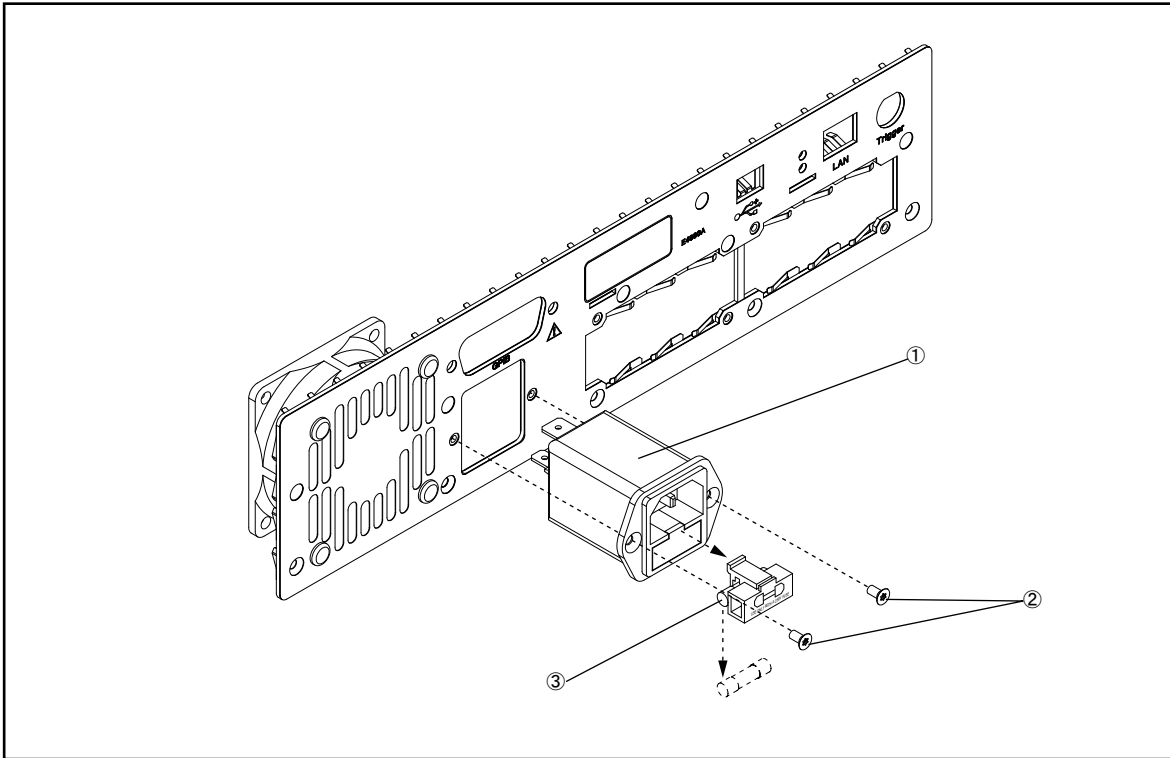

e4980ase1008

Table 5-11 Power Inlet Assembly

Ref. Desig.	Agilent Part Number	Qty.	Description
1	E4980-61612	1	INLET ASSY
2	0515-1946	2	SCREW-MACH M3 X 0.5
3	2110-1017	1	FUSE 3A 250V

Fan Assembly

Figure 5-12 Fan Assembly

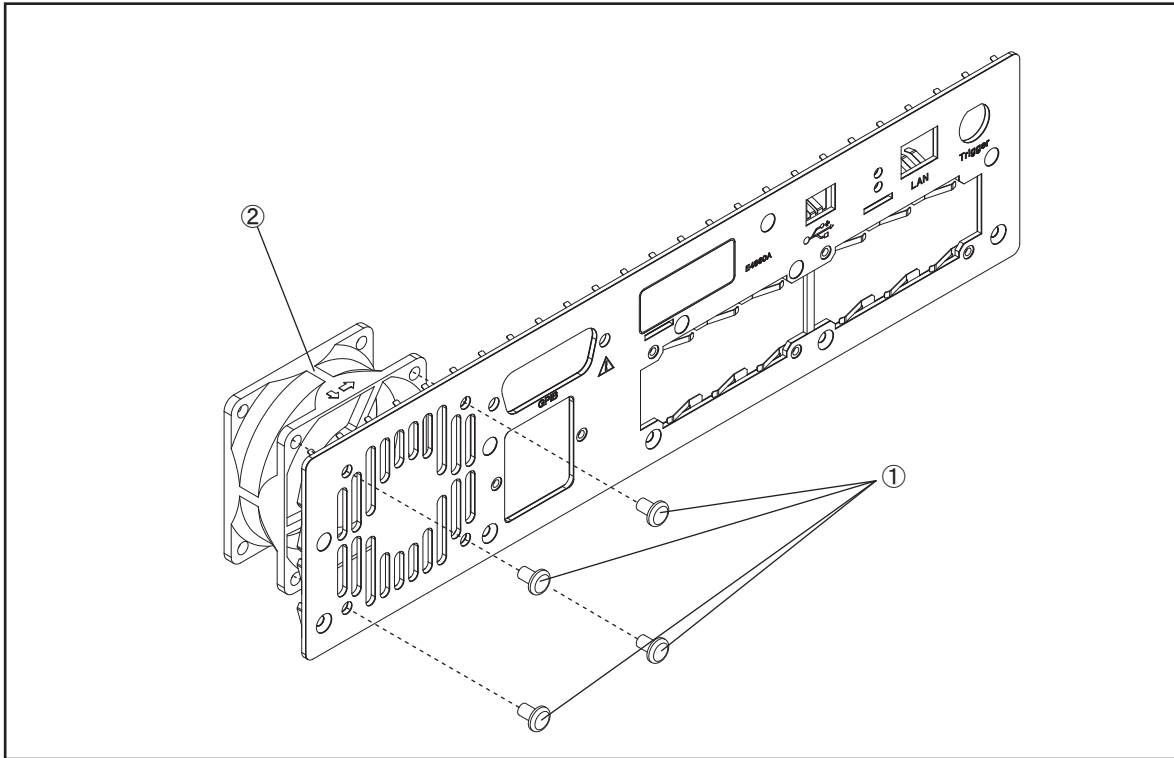

e4980ase1009

Table 5-12 Fan Assembly

Ref. Desig.	Agilent Part Number	Qty.	Description
1	0361-1890	4	RIVET-PUSH-IN 8-MM-HEAD DIA 4-MM-BODY DIA
2	E4980-61613	1	FAN ASSY

Interface Option Assembly

Figure 5-13 Interface Option Assembly

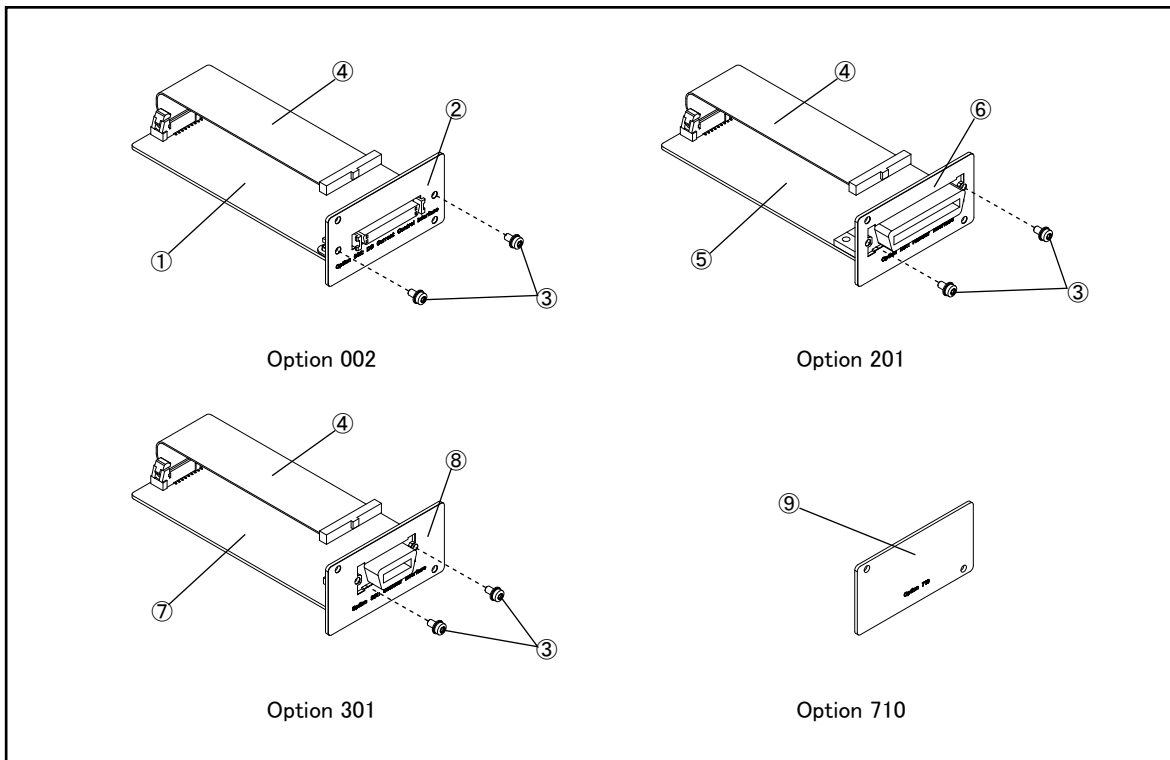

e4980ase1010

Table 5-13 Interface Option Assembly

Ref. Desig.	Agilent Part Number	Qty.	Description
1	E4980-66506	1	CURRENT BIAS I/F (Option 002)
2	E4980-00206	1	DC BIAS PANEL (Option 002)
3	0515-0430	2	SCREW-MACHINE M3 X 0.5
4	E4980-61608	1	UTILITY CABLE ASSY
5	E4980-66507	1	HANDLER I/F (Option 201)
6	E4980-00207	1	HANDLER PANEL (Option 201)
7	E4980-66508	1	SCANNER I/F (Option 301)
8	E4980-00208	1	SCANNER PANEL (Option 301)
9	E4980-00202	1	BLANK PANEL (Option 710)

Wind Angle Assembly

Figure 5-14 Wind Angle Assembly

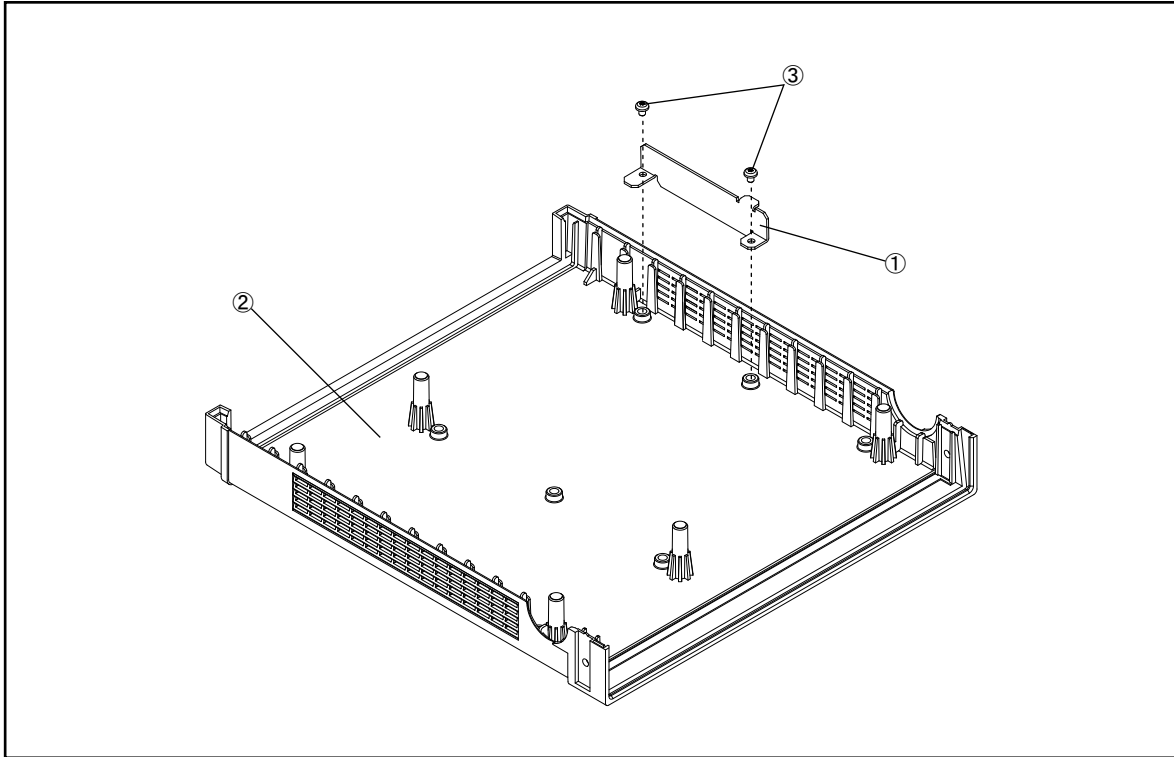

e4980ase1011

Table 5-14 Wind Angle Assembly

Ref. Desig.	Agilent Part Number	Qty.	Description
1	E4980-01201	1	ANGLE WIND
2	5041-7719	1	3/4 RACK MODULE TOP
3	0515-4830	2	SCREW-MACH PAN-HD M4 X 0.7

Label Assembly

Figure 5-15 Label Assembly

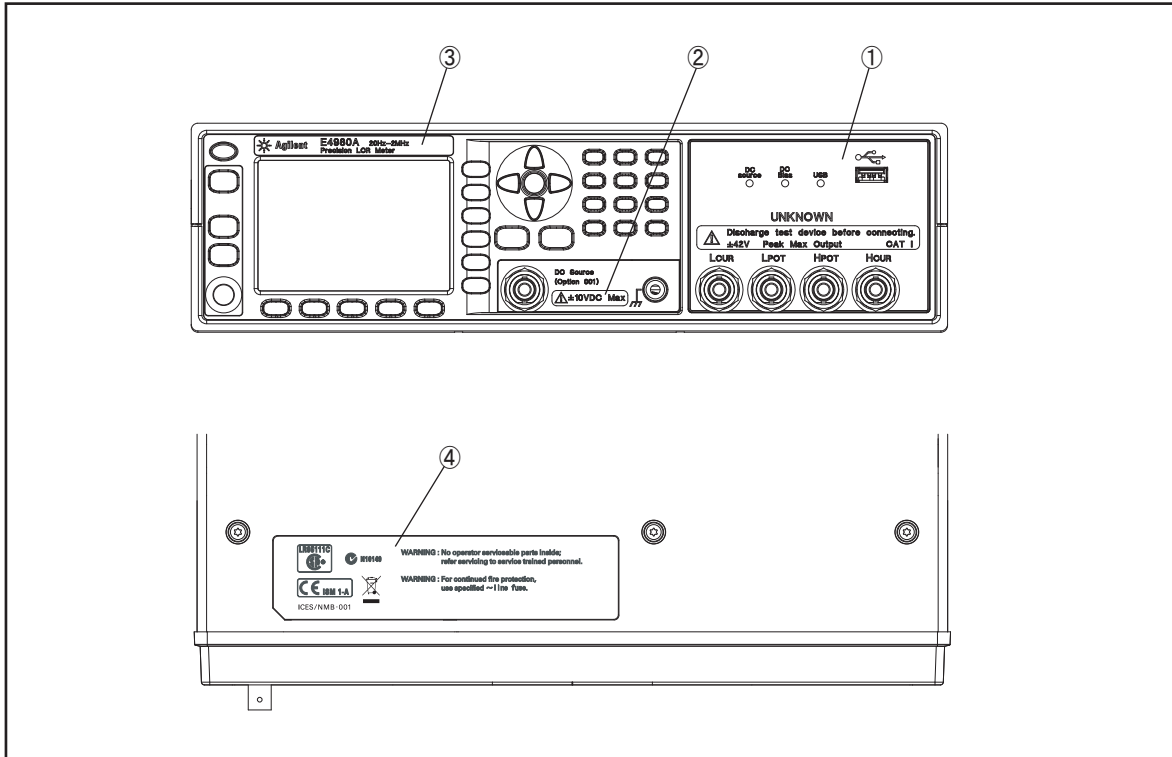

e4980ase1016

Table 5-15 Label Assembly

Ref. Desig.	Agilent Part Number	Qty.	Description
1	E4980-87003	1	GND LABEL
2	E4980-87002	1	BNC LABEL
3	E4980-87001	1	NAME LABEL
4	E4980-87005	1	INFORMATION LABEL

Bumpers & Handle Assembly

Figure 5-16 Bumpers & Handle Assembly

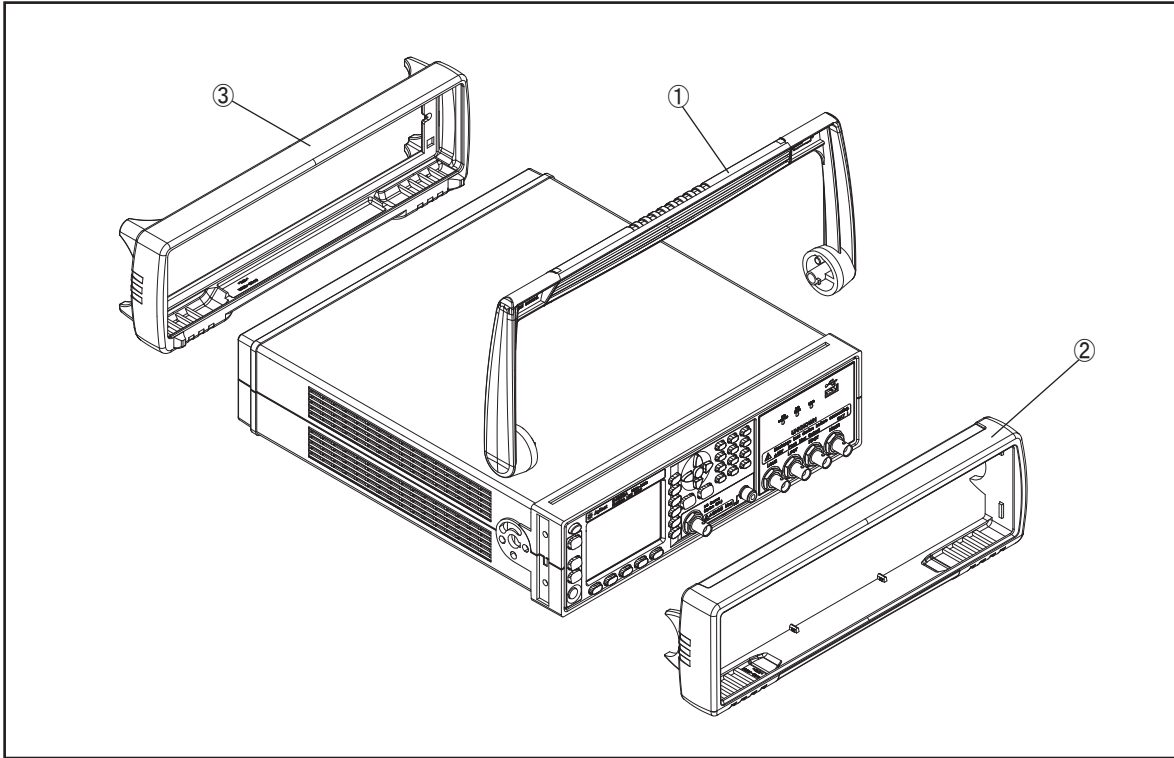

e4980ase1012

Table 5-16 Bumpers & Handle Assembly

Ref. Desig.	Agilent Part Number	Qty.	Description
1	E4980-45001	1	HANDLE
2	34480-46001	1	FRONT BUMPER
3	34480-46002	1	REAR BUMPER

Other Parts

Table 5-17 **Other Parts**

Agilent Part Number	Qty.	Description
E4980-901x0 ^{*1}	1	SERVICE GUIDE
82357-61601	1	USB CABLE
E4980-60102	1	Adapter for Option 002

*1. The number indicated by “x” in the part number of the manual, 0 for the first edition, is incremented by 1 each time a revision is made. The latest edition comes with the product.

Replaceable Parts
Replaceable Parts List

6 Replacement Procedure

This chapter provides procedure for removing and replacing the major assemblies in the E4980A.

Replacing an Assembly

The following steps show the sequence for replacing an assembly in a E4980A Signal Source Analyzer.

1. Identify the faulty group. Refer to Chapter 4, “Troubleshooting.”
2. Order a replacement assembly. Refer to Chapter 5, “Replaceable Parts.”
3. Replace the faulty assembly and determine what adjustments are necessary. Refer to This chapter and Chapter 7, “Post-Repair Procedures.”
4. Perform the necessary adjustments. Refer to Chapter 3, “Adjustment.”
5. Perform the necessary performance tests. Refer to Chapter 2, “Performance Test.”

WARNING

These servicing instructions are for use by qualified personnel only. To avoid electrical shock, do not perform any servicing unless you are qualified to do so.

WARNING

The opening of covers or removal of parts is likely to expose dangerous voltages. Disconnect the instrument from its power supply.

CAUTION

Many of the assemblies in this instrument are very susceptible to damage from ESD(electrostatic discharge). Perform the following procedures only at a static-safe workstation and wear a grounding strap.

Required Tools

The following tools are required for repair of E4980A.

Table 6-1 Required Tools

Assembly	Torque screwdriver				Box torque wrench			
	T6	T8	T10	T20	5.5 mm	7 mm	3/8 in.	5/8 in.
3/4 Rack Module Top				√				
A3 Analog Daughter Board			√	√				
A2 Analog Board			√	√		√		√
Front Panel Assembly			√	√		√		√
Option Interface			√					
PPMC PCA		√		√				
A1 Mother Board		√	√	√				√
Power Supply Assembly		√	√	√	√			√
Base Plate		√	√	√	√	√		√
Rear Panel Assembly		√	√	√	√	√		√
FAN Assembly				√				
GPIB Cable				√		√		
Power Inlet Assembly		√	√	√				√
PCA E4980 USB				√				
Binding Post Sgl			√	√		√	√	√
Inverter	√		√	√		√		√
Front Panel, Key Pad, and Key Flex Circuit			√	√		√		√
Display Interface	√		√	√		√		√

3/4 Rack Module Top Replacement

Tools Required

- Torque screwdriver, TORX T20

Removal Procedure

Refer to Figure 6-1, Figure 6-2, Figure 6-3 and for this procedure.

- Step 1.** Disconnect the power cable from the E4980A.
- Step 2.** Remove the handle, front bumper and rear bumper. (item 1, 2, 3)

NOTE To remove the handle, rotate the handle to a vertical position and pull the arms outwards.

- Step 3.** Work the six TORX T20 screws (item 4) loose from the bottom.
- Step 4.** Remove the 3/4 Rack Module Top with the Wind Angle. (item 5)
- Step 5.** Remove the seven VENT BLOCKS (item 6) from the 3/4 Rack Module Bottom.
- Step 6.** Remove the two TORX T20 screws (item 7) fastening the Wind Angle.
- Step 7.** Remove the Wind Angle (item 8) from the 3/4 Rack Module Top.

Replacement Procedure

- Step 1.** Reverse the order of the removal procedure.

NOTE When you fasten the Wind Angle with the two TORX T20 screws, set screwdriver's torque to 21.1 in-lb.

When you fasten the 3/4 Rack Module Top with the six TORX T20 screws, set screwdriver's torque to 21.1 in-lb.

Figure 6-1 3/4 Rack Module Top Removal (1 of 3)

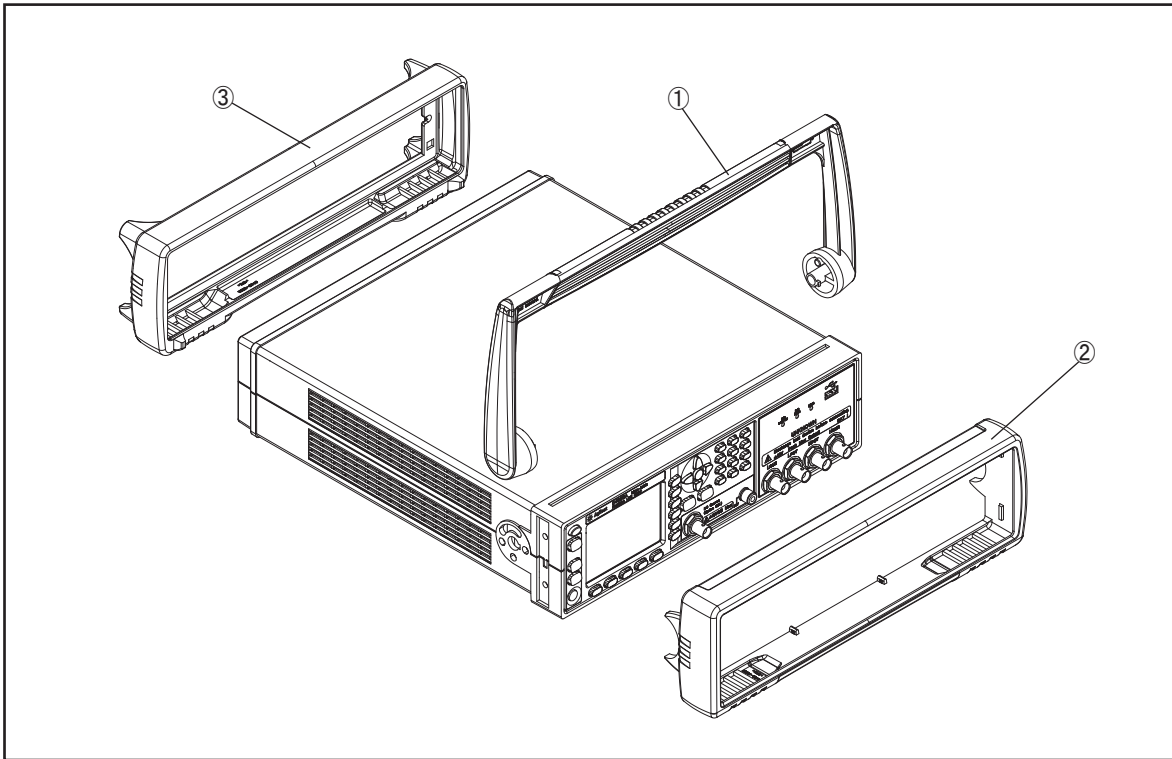

e4980ase1012

Replacement Procedure
3/4 Rack Module Top Replacement

Figure 6-2 3/4 Rack Module Top Removal (2 of 3)

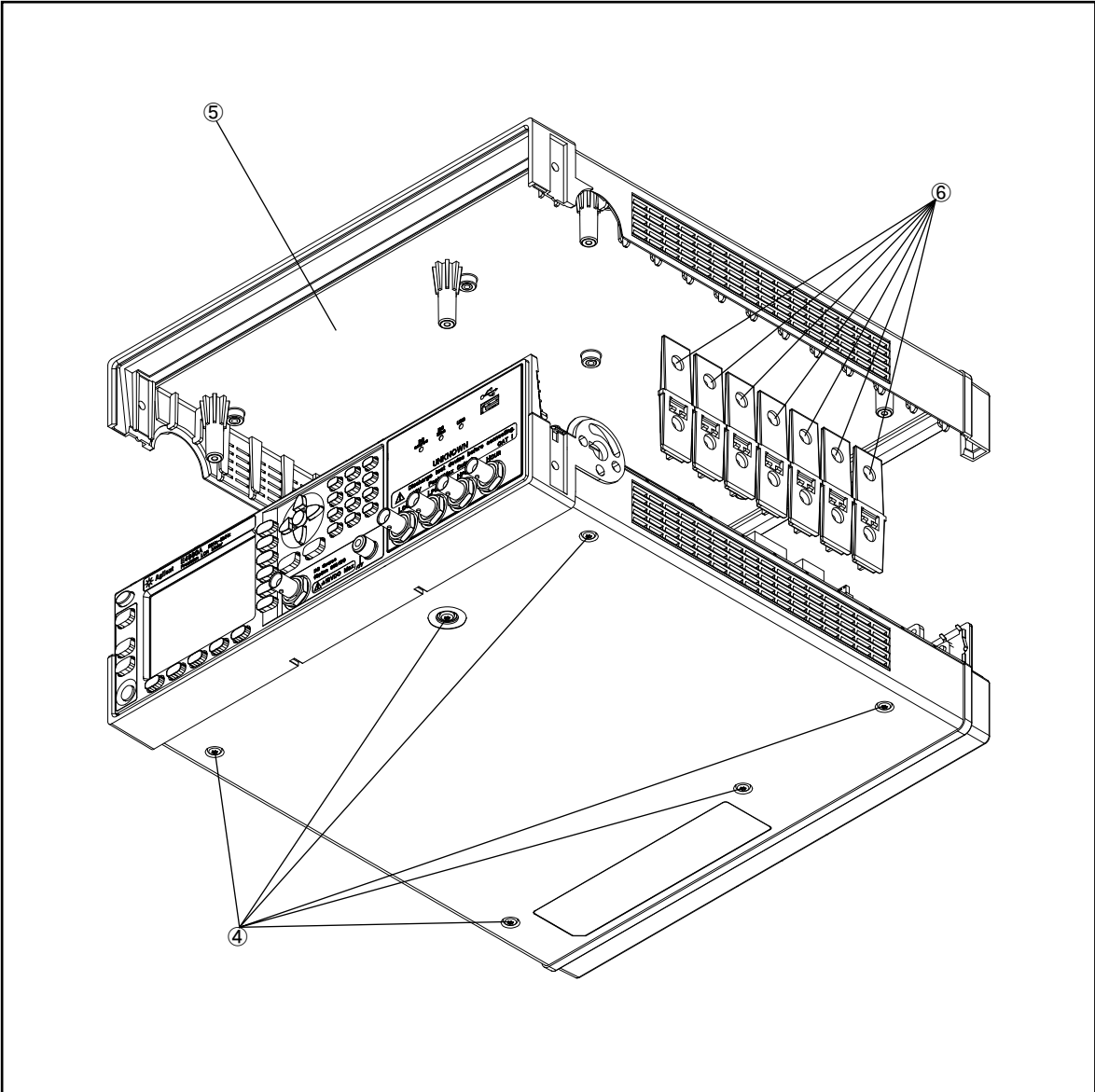

e4980ase1017

Figure 6-3 3/4 Rack Module Top Removal (3 of 3)

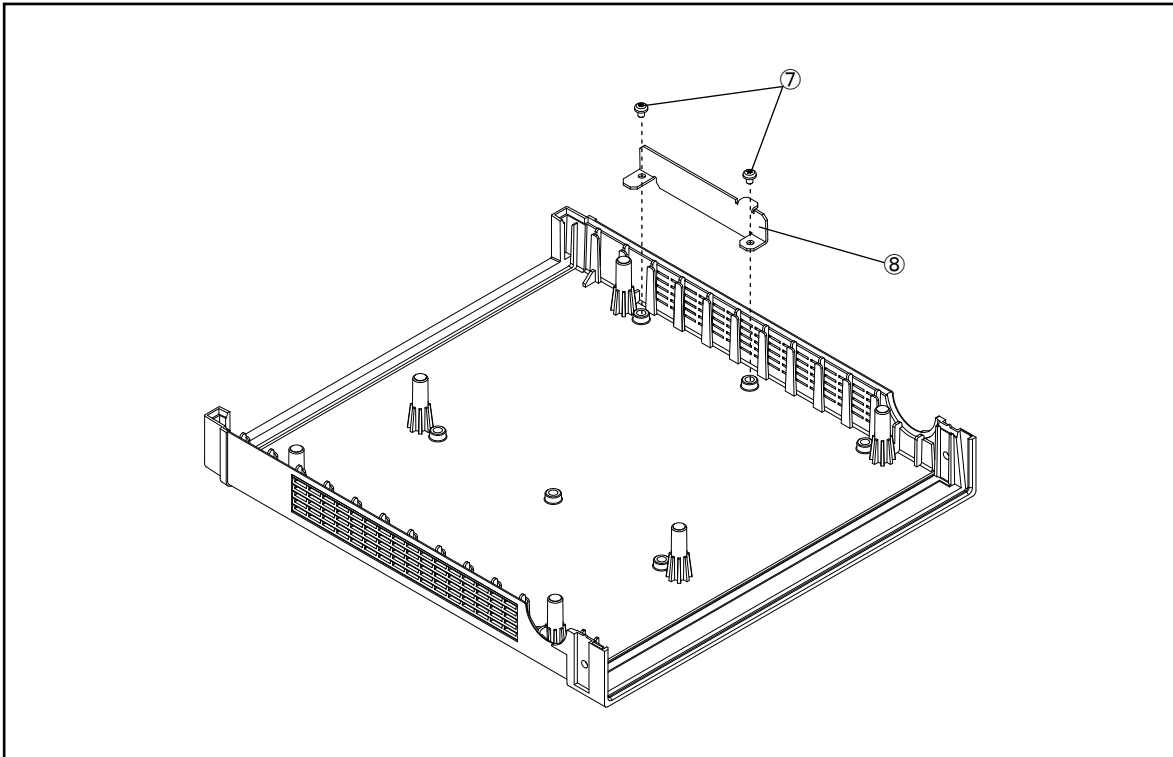

e4980ase1038

A3 Analog Daughter Board Replacement

Tools Required

- Torque screwdriver, TORX T10
- Torque screwdriver, TORX T20

Removal Procedure

Refer to Figure 6-4 and for this procedure.

- Step 1.** Remove the 3/4 rack module top as described in “3/4 Rack Module Top Replacement” on page 90.
- Step 2.** Disconnect the front USB cable (item 1) from the front panel assembly.
- Step 3.** Disconnect the LCD cable (item 2) from the A1 Mother Board.
- Step 4.** Disconnect the power supply cable (item 3) from the A3 Analog Daughter Board.

NOTE Pull out the power supply cable straight without touching the hook on the cable connector.

- Step 5.** Disconnect the two SMB cables (item 4) from the A3 Analog Daughter Board.
- Step 6.** Disconnect the Analog Source Cable (item 5) from the A3 Analog Daughter Board.
- Step 7.** Remove the four TORX T10 screws (item 6) fastening the A3 Analog Daughter Board.
- Step 8.** Remove the A3 Analog Daughter Board.

Replacement Procedure

- Step 1.** Reverse the order of the removal procedure.

NOTE When you replace the A3 Analog Daughter Board, stick the Foot Bumper (item 7) to the backside of the board as location of sub-figure in Figure 6-4.

When you fasten the A3 Analog Daughter Board with the four TORX T10 screws, set screwdriver's torque to 8.7 in-lb.

When you connect the LCD Cable to the A1 Mother Board, make sure the LCD Cable lies beneath the Analog Source Cable.

Figure 6-4 A3 Analog Daughter Board Removal

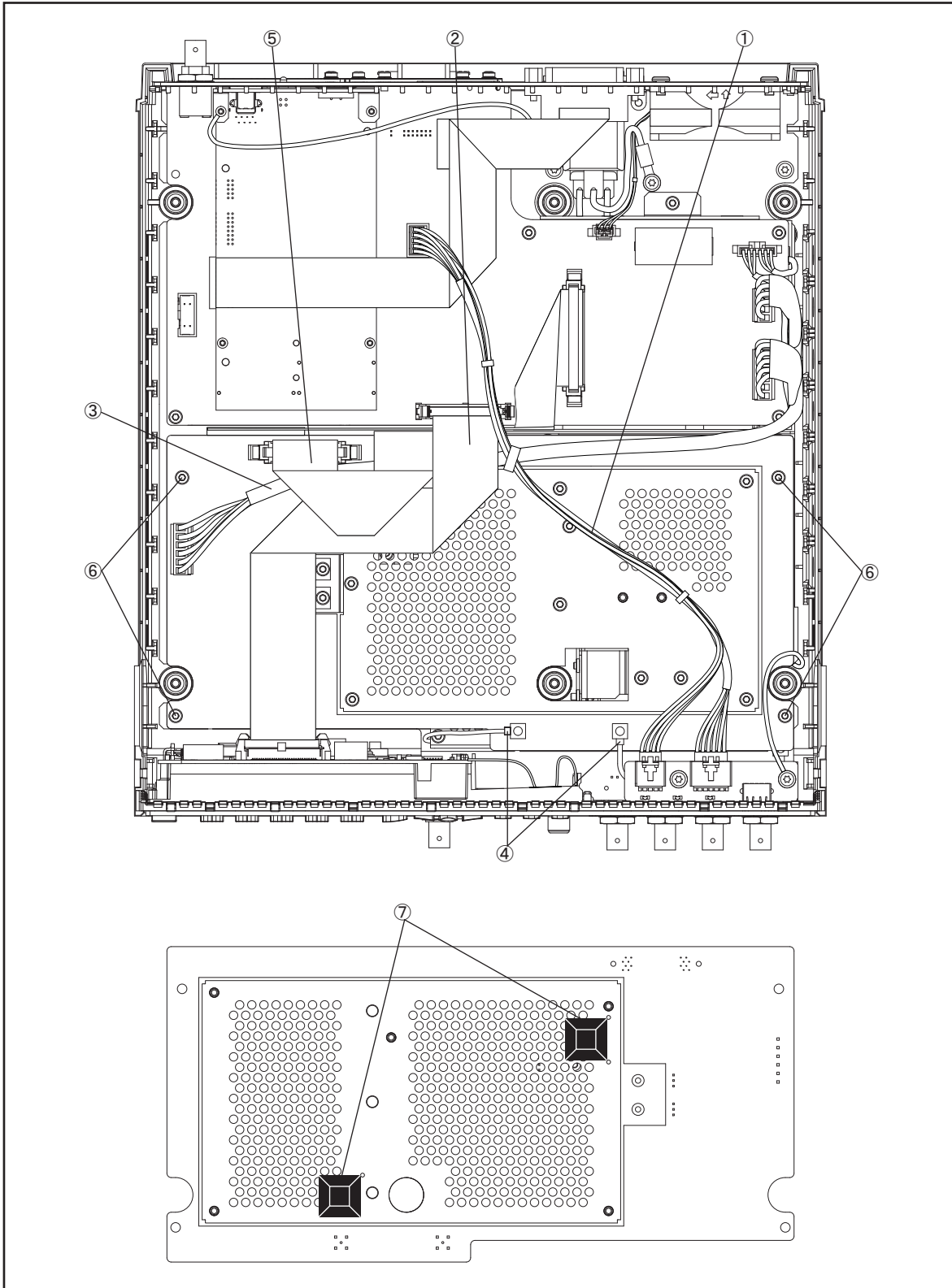

e4980ase1018

A2 Analog Board Replacement

Tools Required

- Torque screwdriver, TORX T10
- Torque screwdriver, TORX T20
- Box torque wrench, 7 mm
- Box torque wrench, 5/8 inch

Removal Procedure

Refer to Figure 6-5 and for this procedure.

- Step 1.** Remove the 3/4 rack module top as described in “3/4 Rack Module Top Replacement” on page 90.
- Step 2.** Remove the A3 Analog Daughter Board as described in “A3 Analog Daughter Board Replacement” on page 94.
- Step 3.** Disconnect the Mother-Analog Cable (item 1) from the A2 Analog Board.
- Step 4.** Disconnect the Analog Source Cable (item 2) from the A2 Analog Board.
- Step 5.** Remove the four 7 mm Standoff (item 3) from the A2 Analog Board.
- Step 6.** Remove the TORX T20 screw (item 4) from the PCA E4980 USB. Then, Disconnect the ground cable from the PCA E4980 USB.
- Step 7.** Lift the A2 Analog Board and front panel toward upside.
- Step 8.** Remove the five 5/8 inch nuts and washers (item 5) fastening the BNC connector.
- Step 9.** Remove the A2 Analog Board from Front Panel.
- Step 10.** Disconnect the two SMB cables (item 6) from the A2 Analog Board.

Replacement Procedure

- Step 1.** Reverse the order of the removal procedure.

NOTE

When you fasten the A2 Analog Board with the five 5/8 inch nuts and washers, set box torque wrench's torque to 17.4 in-lb.

When you fasten the A2 Analog Board with the four 7 mm Standoff, set box torque wrench's torque to 8.7 in-lb.

Figure 6-5 A2 Analog Board Removal

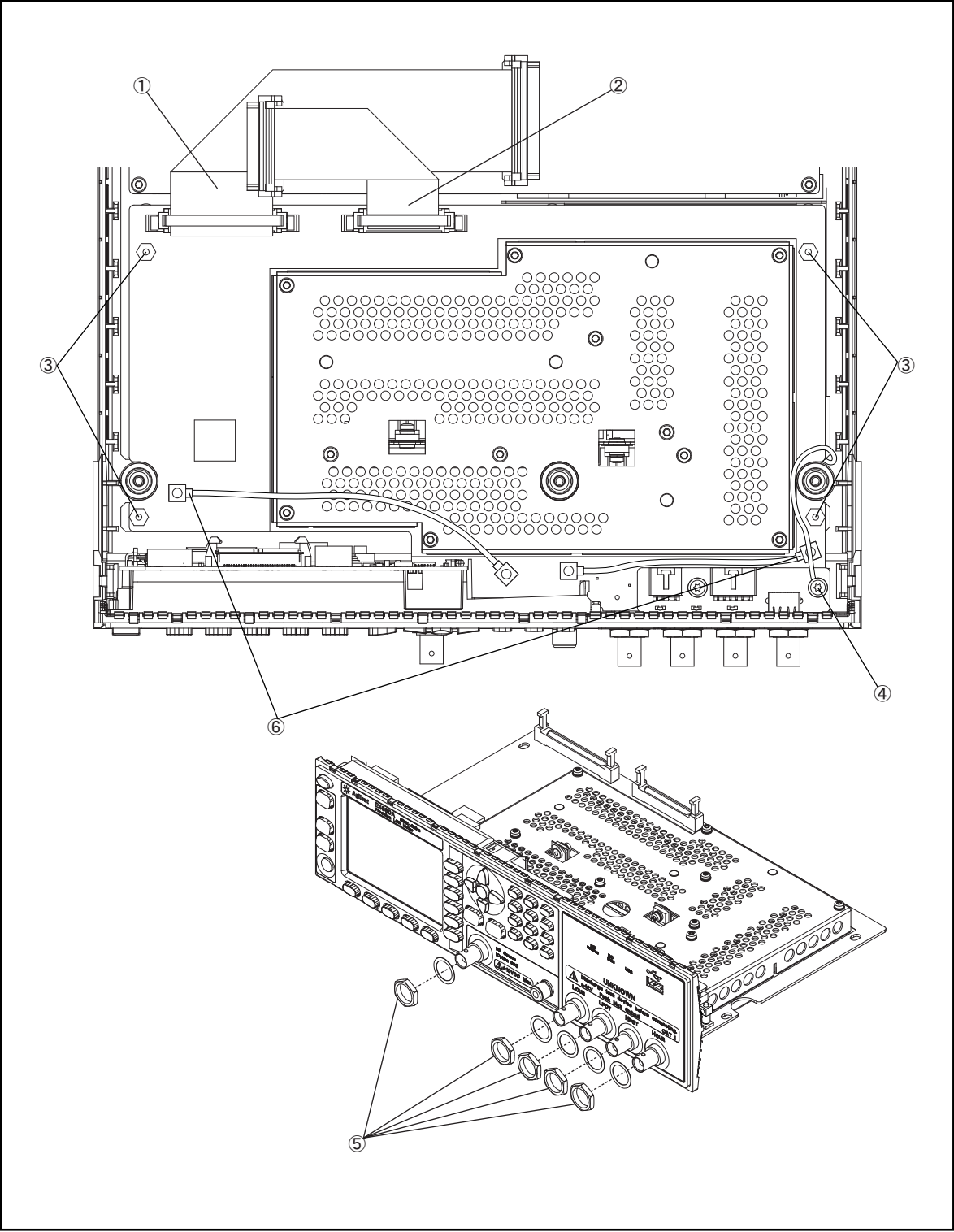

e4980ase1027

Front Panel Assembly Removal

Tools required

- Torque screwdriver, TORX T10
- Torque screwdriver, TORX T20
- Box torque wrench, 7 mm
- Box torque wrench, 5/8 inch

Removal Procedure

The Front Panel Assembly removal process is same as A2 Analog Board removal process. Refer to removal procedure of the “A2 Analog Board Replacement” on page 96.

Replacement Procedure

The Front Panel Assembly replacement process is reverse order of the A2 Analog Board removal process. Refer to removal procedure of the “A2 Analog Board Replacement” on page 96.

Option Interface Replacement

Tools Required

- Torque screwdriver, TORX T10

Removal Procedure

Refer to Figure 6-6 for this procedure.

- Step 1.** Remove the two TORX T10 screws (item 1) fastening the Option Interface.
- Step 2.** Pulls the Option Interface carefully.
- Step 3.** Carefully disconnect the flat cable (item 2) of Option Interface side. Release the cable's connector by pressing the locking hooks at the sides of the connector.
- Step 4.** Remove the two TORX T10 screws (item 3) fastening the option panel.
- Step 5.** Remove the option panel from the option interface board.
- Step 6.** Disconnect the flat cable from the A1 Mother Board connector (item 4).

Replacement Procedure

- Step 1.** Reverse the order of the removal procedure.

NOTE

When you fasten the option panel with the two TORX T10 screws, set screwdriver's torque to 8.7 in-lb.

When you fasten the interface card with the two TORX T10 screws, set screwdriver's torque to 8.7 in-lb.

Figure 6-6 Option Interface Removal

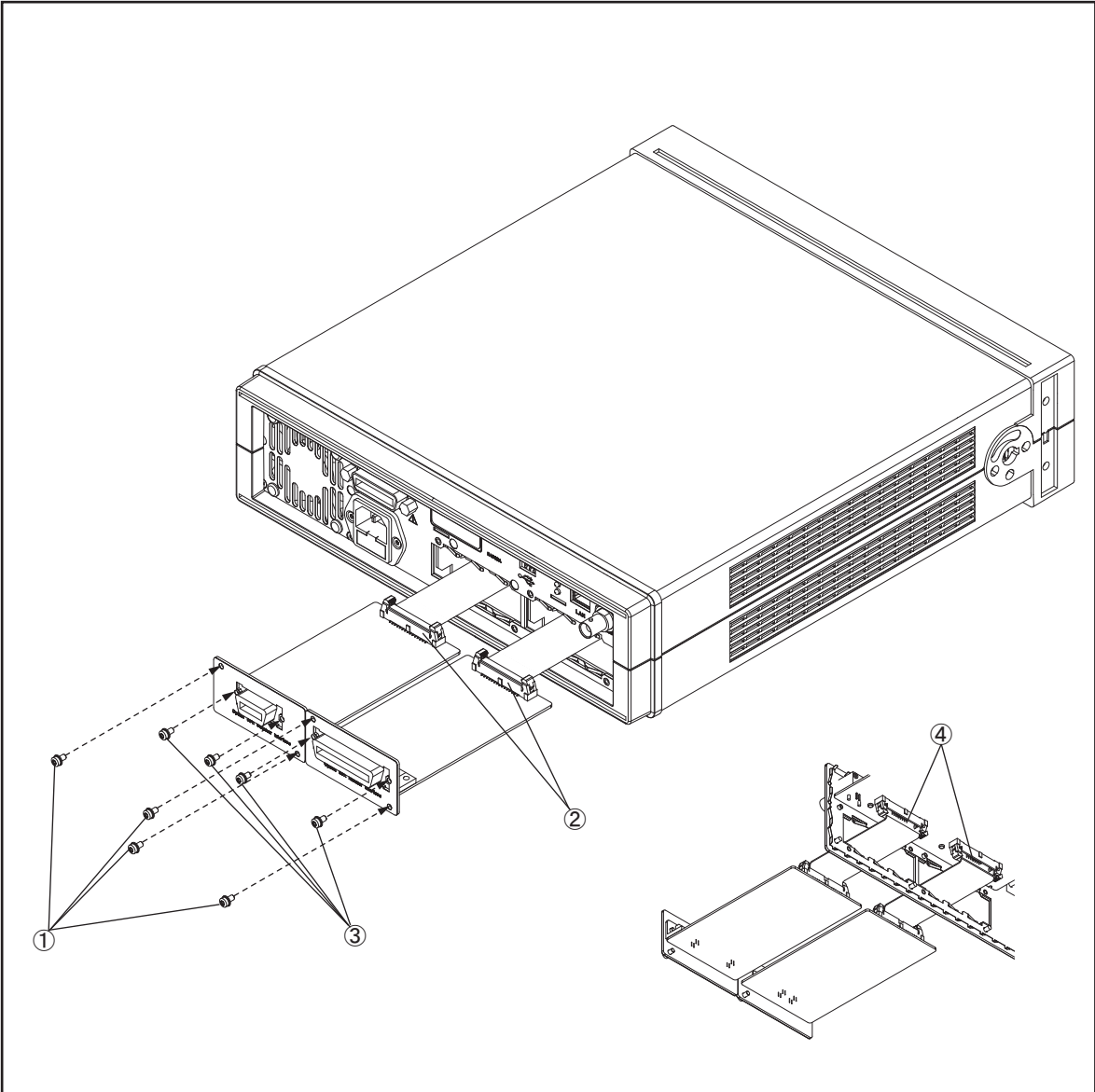

e4980ase1022

PPMC PCA Replacement

Tools Required

- Torque screwdriver, TORX T20
- Torque screwdriver, TORX T8

Removal Procedure

Refer to Figure 6-7 for this procedure.

- Step 1.** Remove the 3/4 rack module top as described in “3/4 Rack Module Top Replacement” on page 90.
- Step 2.** Remove the four TORX T8 screws (item 1) fastening the PPMC PCA.
- Step 3.** Remove the Angle CPU (item 2) from the PPMC PCA.
- Step 4.** Disconnect the ground cable (item 3).
- Step 5.** Carefully disconnect the PPMC PCA from A1 Mother Board.
- Step 6.** Carefully disconnect the GPIB cable (item 4) from PPMC PCA.
- Step 7.** Remove the USB gasket (item 5) from the PPMC PCA.

Replacement Procedure

- Step 1.** Reverse the order of the removal procedure.

NOTE

When you fasten the PPMC PCA with the four TORX T8 screws, set screwdriver's torque to 3 in-lb.

Replacement Procedure
PPMC PCA Replacement

Figure 6-7 PPMC PCA Removal

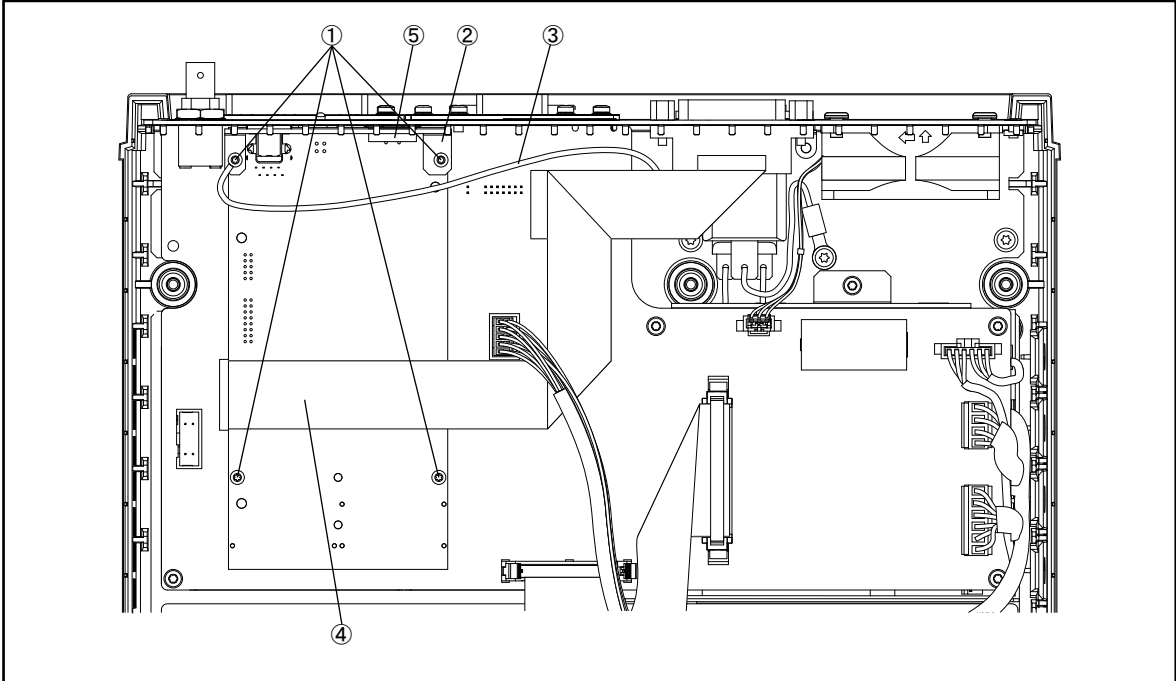

e4980ase1020

A1 Mother Board Replacement

Tools Required

- Torque screwdriver, TORX T20
- Torque screwdriver, TORX T8
- Torque screwdriver, TORX T10
- Box torque wrench, 5/8 inch

Removal Procedure

Refer to Figure 6-8 for this procedure.

- Step 1.** Remove the 3/4 rack module top as described in “3/4 Rack Module Top Replacement” on page 90.
- Step 2.** Remove the PPMC PCA as described in “PPMC PCA Replacement” on page 101.
- Step 3.** Disconnect the Mother-Analog cable (item 1) from A1 Mother Board.
- Step 4.** Disconnect the front USB cable (item 2) from A1 Mother Board.
- Step 5.** Disconnect the cable power control (item 3) from A1 Mother Board.
- Step 6.** Disconnect the power supply cables (item 4) from A1 Mother Board.

NOTE Pull out the power supply cables straight without touching the hook on the cable connector.

- Step 7.** Disconnect the LCD cable (item 5) from Front Panel Assembly.
- Step 8.** Disconnect the fan cable (item 6) from FAN Assembly.
- Step 9.** Remove the 5/8 inch nut and washer (item 7) fastening the BNC connector.
- Step 10.** Remove the five TORX T10 screws (item 8) from the A1 Mother Board.
- Step 11.** Remove the A1 Mother Board toward front side.

Replacement Procedure

- Step 1.** Reverse the order of the removal procedure.

NOTE When you fasten the BNC connector with the 5/8 inch nut and washer, set box torque wrench's torque to 17.4 in-lb.

When you fasten the A1 Mother Board with the five TORX T10 screws, set screwdriver's torque to 8.7 in-lb for left-under screw of item 8 in the Figure 6-8, and set screwdriver's torque to 4.35 in-lb for other screws.

When you connect the LCD Cable to the A1 Mother Board, make sure the LCD Cable is at the bottom of the Analog Source Cable.

Replacement Procedure
A1 Mother Board Replacement

Figure 6-8 A1 Mother Board Replacement

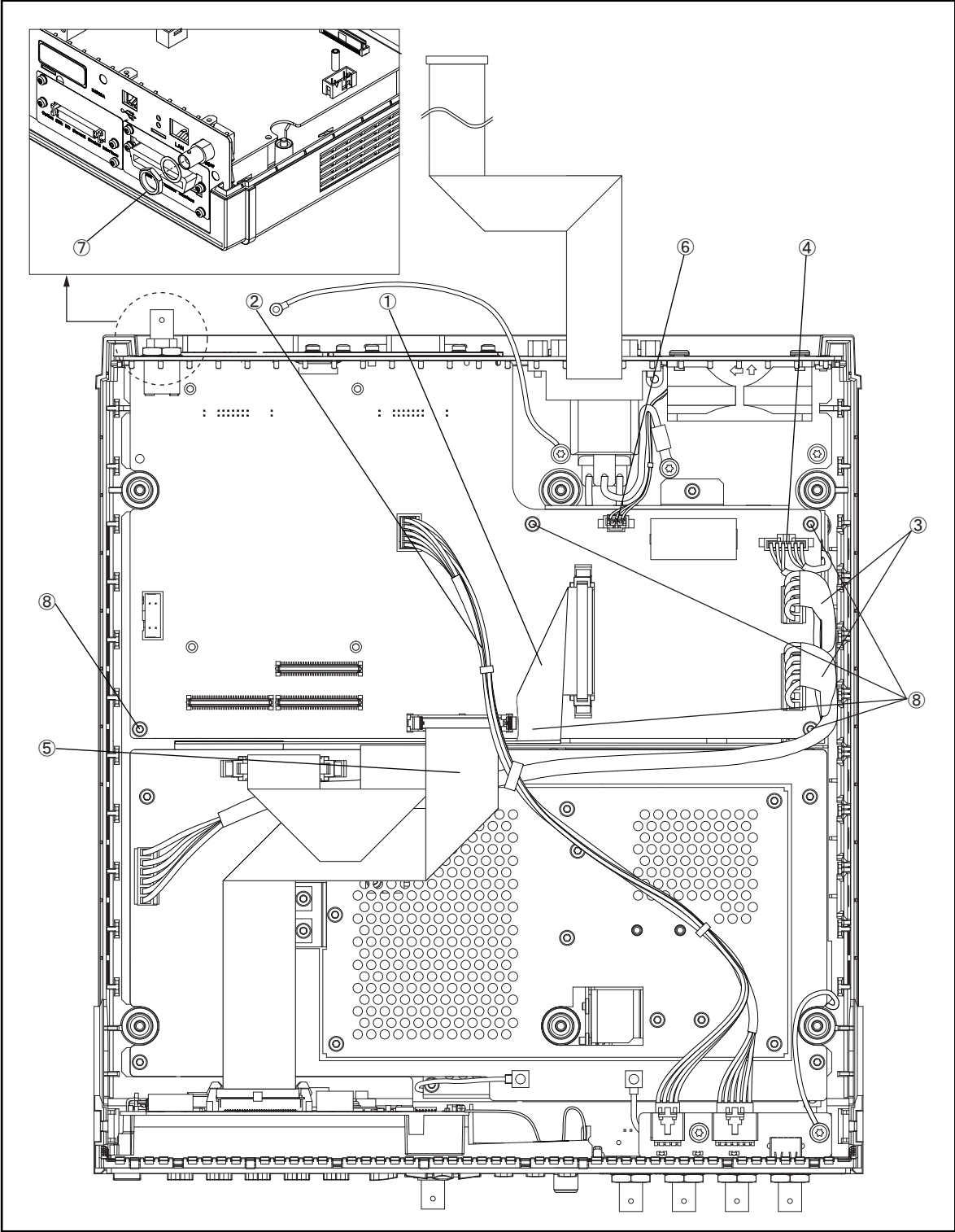

e4980ase1021

Power Supply Assembly Replacement

Tools Required

- Torque screwdriver, TORX T20
- Torque screwdriver, TORX T8
- Torque screwdriver, TORX T10
- Box torque wrench, 5/8 inch
- Box torque wrench, 5.5 mm

Removal Procedure

Refer to Figure 6-9 for this procedure.

- Step 1.** Remove the 3/4 rack module top as described in “3/4 Rack Module Top Replacement” on page 90.
- Step 2.** Remove the PPMC PCA as described in “PPMC PCA Replacement” on page 101.
- Step 3.** Remove the A1 Mother Board as described in “A1 Mother Board Replacement” on page 103.
- Step 4.** Disconnect the cable of the inlet (item 1) from the Power Supply Assembly.
- Step 5.** Remove the four 5.5 mm Standoff (item 2).
- Step 6.** Remove the TORX T10 screw (item 3) fastening the CPU cover.
- Step 7.** Remove the CPU cover (item 4).
- Step 8.** Remove the Power Supply Assembly with the cable power control.
- Step 9.** Disconnect the cable power control (item 5) from the Power Supply Assembly.

NOTE

Do not pull out the power cable (P/N : E4980-61601) from the Power Supply Assembly when you detach the Power Supply Assembly. There is a possibility that the Power Supply Assembly could break when the power cable is forcibly pulled out. (Refer to sub-figure in Figure 6-9.)

Replacement Procedure

- Step 1.** Reverse the order of the removal procedure.

NOTE

When you fasten the CPU cover with the TORX T10 screw, set screwdriver's torque to 8.7 in-lb.

When you fasten the Power Supply Assembly with the 5.5 mm Standoff, set box torque wrench's torque to 7 in-lb.

When you replace the Power Supply Assembly with a new one, use a new power cable (P/N : E4980-61601).

Replacement Procedure
Power Supply Assembly Replacement

Figure 6-9 Power Supply Assembly Removal

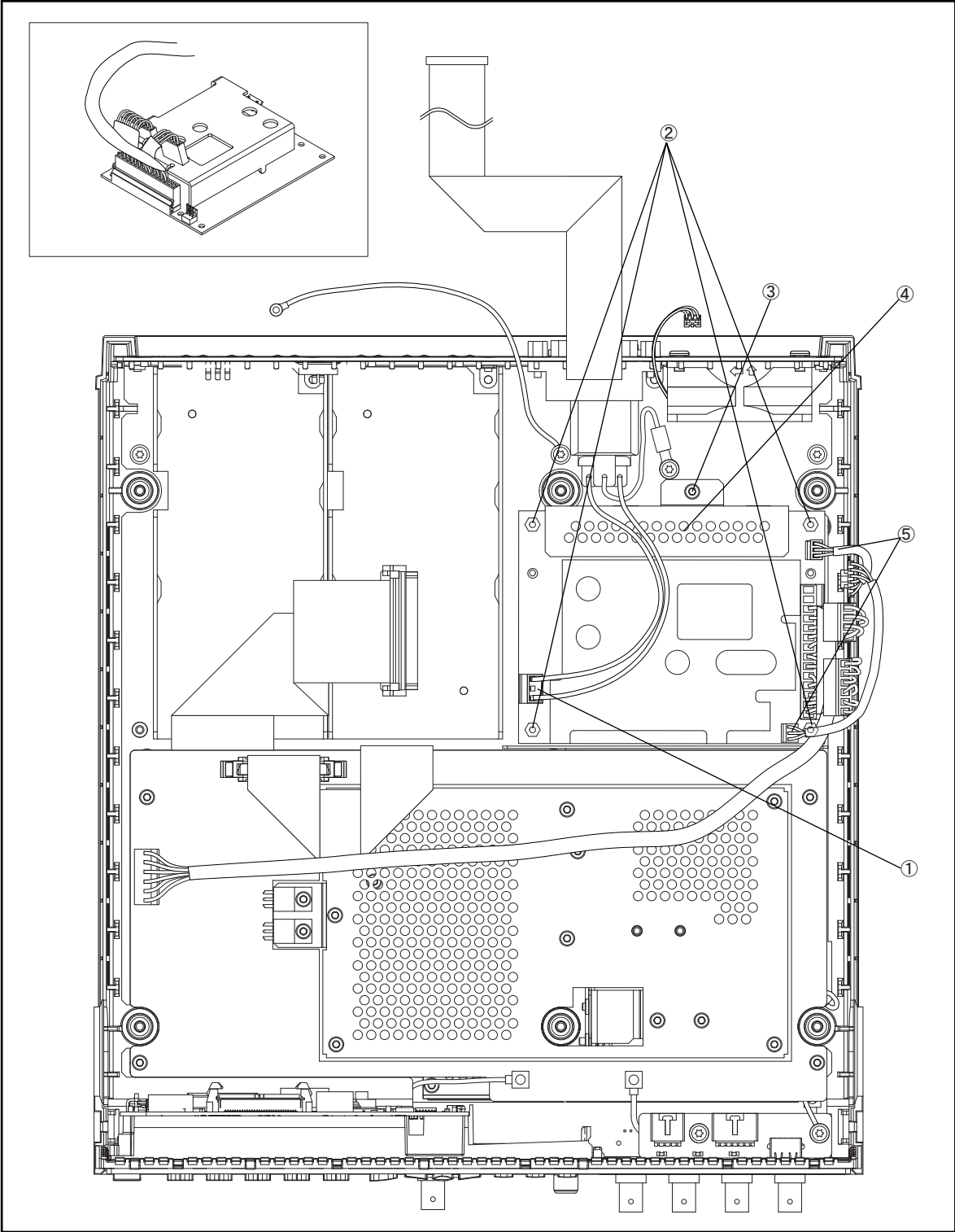

e4980ase1023

Base Plate Replacement

Tools Required

- Torque screwdriver, TORX T20
- Torque screwdriver, TORX T8
- Torque screwdriver, TORX T10
- Box torque wrench, 5/8 inch
- Box torque wrench, 5.5 mm
- Box torque wrench, 7 mm

Removal Procedure

Refer to Figure 6-10 for this procedure.

- Step 1.** Remove the Option Interface as described in “Option Interface Replacement” on page 99.
- Step 2.** Remove the 3/4 Rack Module Top as described in “3/4 Rack Module Top Replacement” on page 90.
- Step 3.** Remove the A3 Analog Daughter Board as described in “A3 Analog Daughter Board Replacement” on page 94.
- Step 4.** Remove the A2 Analog Board as described in “A2 Analog Board Replacement” on page 96.
- Step 5.** Remove the two TORX T10 screws (item 1) fastening the Shield Angle.
- Step 6.** Remove the Shield Angle (item 2) from the Base Plate.
- Step 7.** Remove the PPMC PCA as described in “PPMC PCA Replacement” on page 101.
- Step 8.** Remove the A1 Mother Board as described in “A1 Mother Board Replacement” on page 103.
- Step 9.** Remove the Power Supply Assembly as described in “Power Supply Assembly Replacement” on page 105.
- Step 10.** Remove the seven TORX T20 screws (item 3) fastening the Base Plate.
- Step 11.** Remove the two TORX T20 screws (item 4) fastening the Base Plate and the ground cables. Then, remove the ground cables (item 5).
- Step 12.** Remove the Rack Module Bottom from the Base Plate.
- Step 13.** Remove the Rear Panel as described from Step 9 to Step 11 in “Rear Panel Assembly Replacement” on page 109.
- Step 14.** Remove the Base Plate from the Rear Panel.

Replacement Procedure

- Step 1.** Reverse the order of the removal procedure.

Replacement Procedure

Base Plate Replacement

NOTE

When you fasten the ground cable and the Base Plate with the two TORX T20 screws, set screwdriver's torque to 21.1 in-lb.

When you fasten the Base Plate with the seven TORX T20 screws, set screwdriver's torque to 21.1 in-lb.

When you fasten the Shield Angle with the two TORX T10 screws, set screwdriver's torque to 8.7 in-lb.

Figure 6-10 **Base Plate Board Removal**

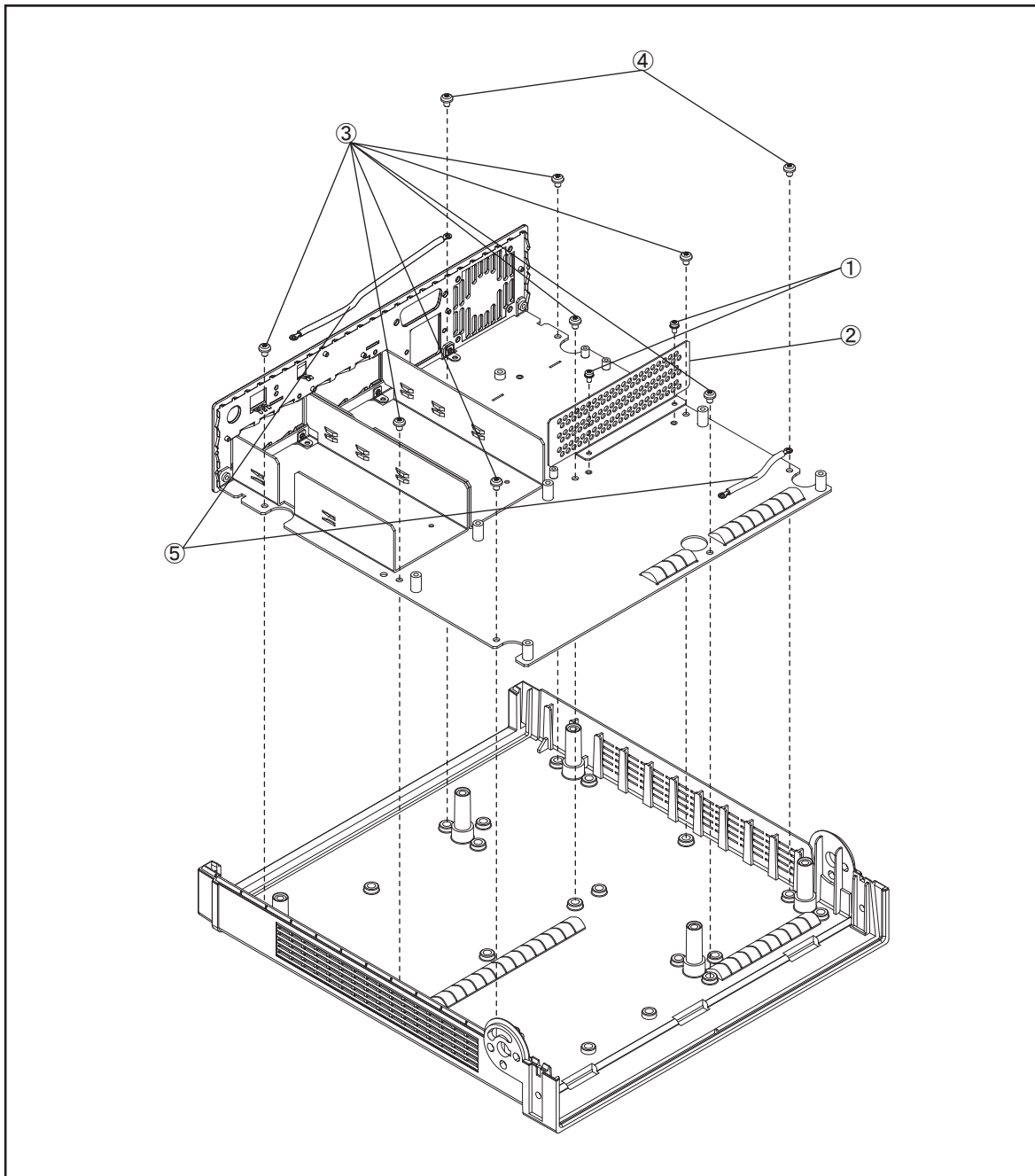

e4980ase1044

Rear Panel Assembly Replacement

Tools Required

- Torque screwdriver, TORX T20
- Torque screwdriver, TORX T8
- Torque screwdriver, TORX T10
- Box torque wrench, 5/8 inch
- Box torque wrench, 5.5 mm
- Box torque wrench, 7 mm

Removal Procedure

Refer to Figure 6-11 for this procedure.

- Step 1.** Remove the Option Interface as described in “Option Interface Replacement” on page 99.
- Step 2.** Remove the 3/4 Rack Module Top as described in “3/4 Rack Module Top Replacement” on page 90.
- Step 3.** Remove the A3 Analog Daughter Board as described in “A3 Analog Daughter Board Replacement” on page 94.
- Step 4.** Remove the A2 Analog Board as described in “A2 Analog Board Replacement” on page 96.
- Step 5.** Remove the PPMC PCA as described in “PPMC PCA Replacement” on page 101.
- Step 6.** Remove the A1 Mother Board as described in “A1 Mother Board Replacement” on page 103.
- Step 7.** Remove the Power Supply Assembly as described in “Power Supply Assembly Replacement” on page 105.
- Step 8.** Remove the bottom clamshell as described from Step 10 to Step 12 in “Base Plate Replacement” on page 107.
- Step 9.** Remove the one TORX T20 screw (item 1) fastening the ground cable.
- Step 10.** Remove the five TORX T10 screws (item 2) fastening the Rear Panel Assembly.
- Step 11.** Remove the Rear Panel Assembly from the Base Plate.

Replacement Procedure

- Step 1.** Reverse the order of the removal procedure.

NOTE

When you fasten the Rear Panel with the five TORX T10 screws, set screwdriver's torque to 8.7 in-lb.

When you fasten the ground cable with the TORX T20 screw, set screwdriver's torque to 21.1 in-lb.

Replacement Procedure
Rear Panel Assembly Replacement

Figure 6-11 Rear Panel Assembly Removal

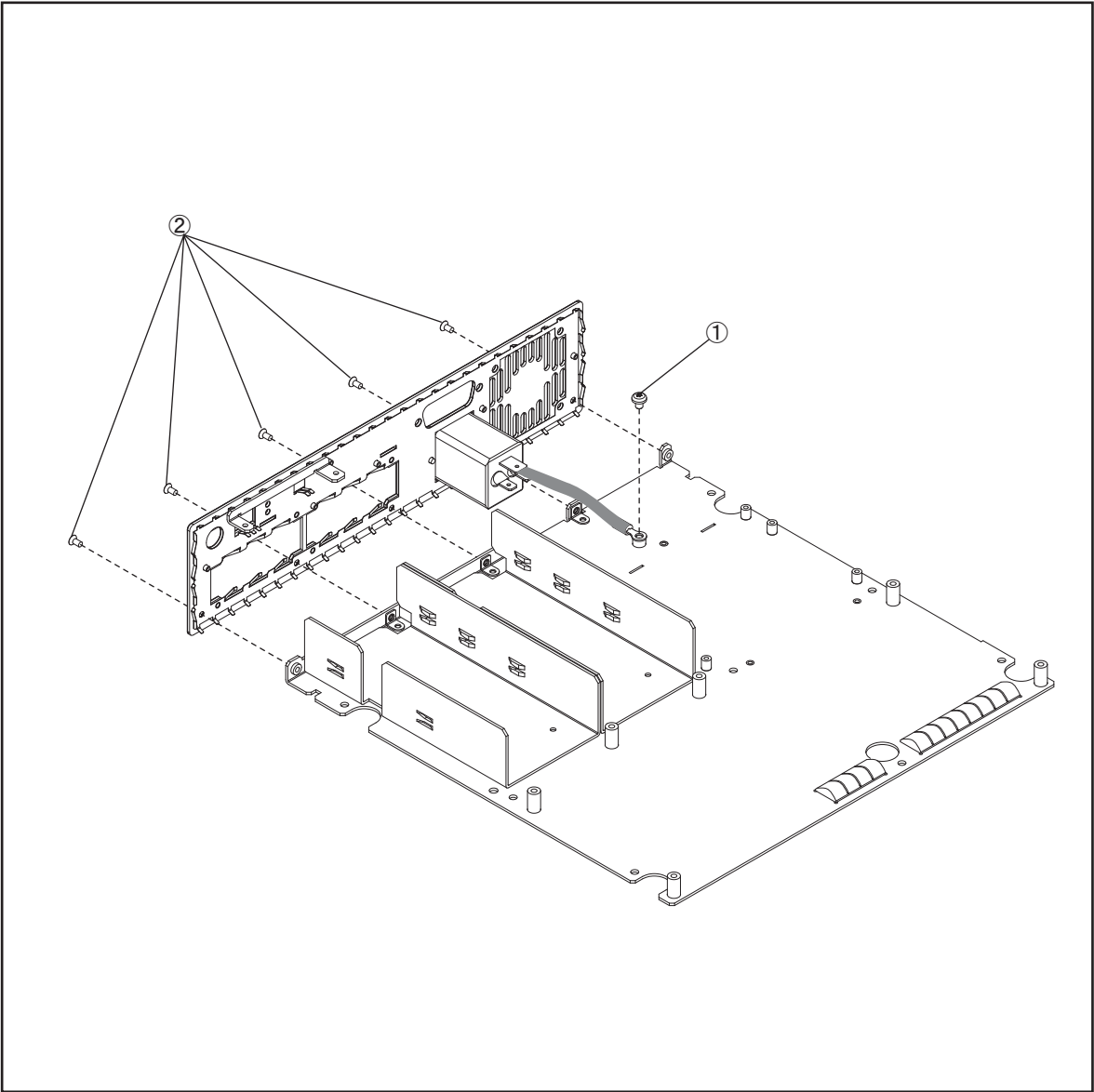

e4980ase1025

FAN Assembly Replacement

Tools Required

- Torque screwdriver, TORX T20

Removal Procedure

Refer to Figure 6-12 for this procedure.

- Step 1.** Remove the 3/4 Rack Module Top as described in “3/4 Rack Module Top Replacement” on page 90.
- Step 2.** Disconnect the connector of the fan cable on the A1 Mother Board (item 1) from Fan Assembly.
- Step 3.** Push the four Rivets (item 2) from the inside, then, remove the four Rivets fastening the Fan Assembly.

NOTE If you can not push the rivets out easily, push the rivets out using a flat-edge driver.

- Step 4.** Remove the Fan Assembly (item 3) from the Rear Panel.

Replacement Procedure

- Step 1.** Reverse the order of the removal procedure.

NOTE When you replace the Fan Assembly, use new rivets.

Replacement Procedure
FAN Assembly Replacement

Figure 6-12 FAN Assembly Removal

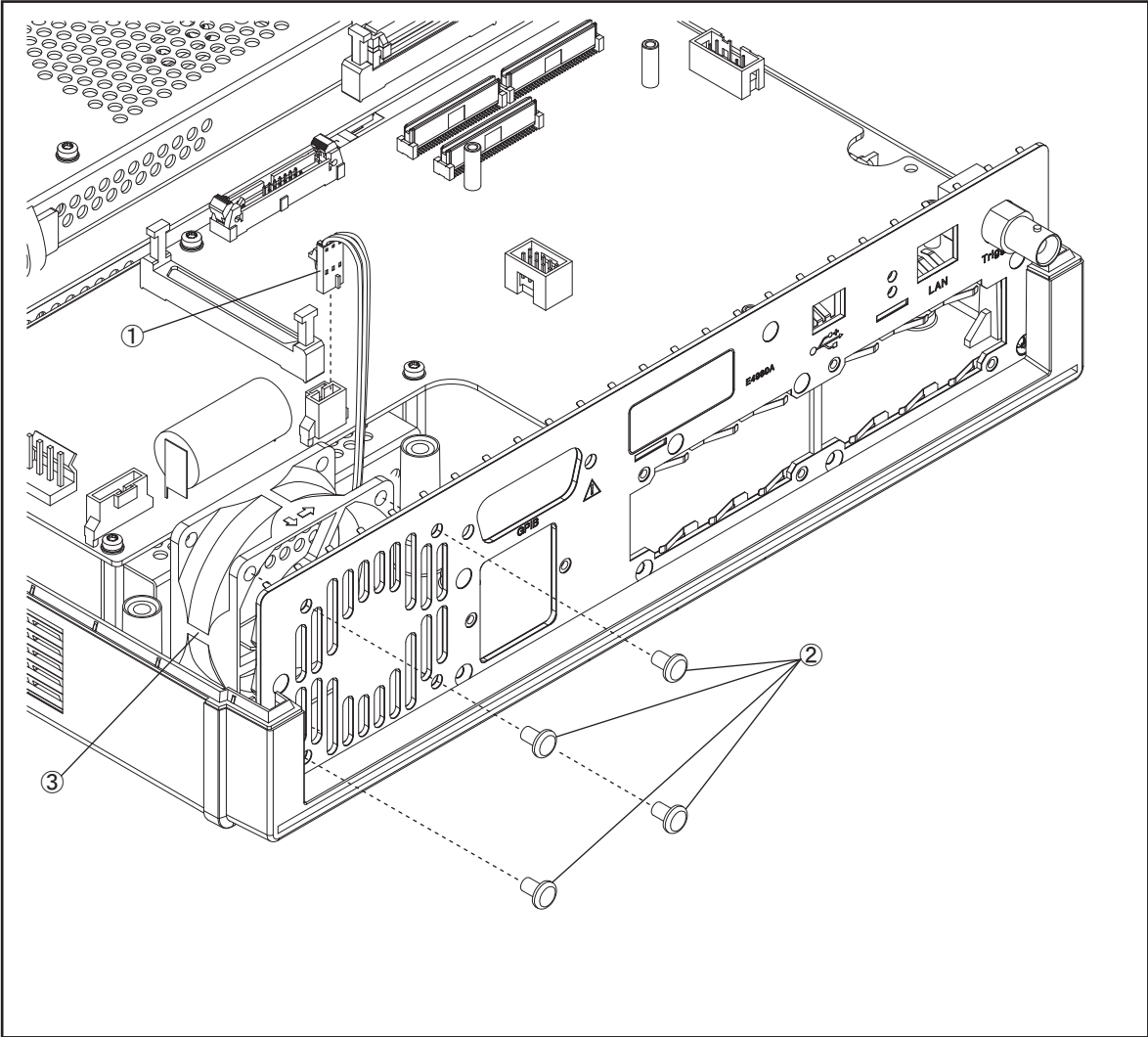

e4980ase1041

GPIB Cable Replacement

Tools Required

- Torque screwdriver, TORX T20
- Box torque wrench, 7 mm

Removal Procedure

Refer to Figure 6-13 for this procedure.

- Step 1.** Remove the 3/4 Rack Module Top as described in “3/4 Rack Module Top Replacement” on page 90.
- Step 2.** Disconnect the GPIB Cable connector (item 1) from PPM PCA card.
- Step 3.** Remove the two 7mm standoff (item 2) fastening the GPIB cable.
- Step 4.** Remove the GPIB Cable (item 3) from the Rear Panel Assembly.

Replacement Procedure

- Step 1.** Reverse the order of the removal procedure.

NOTE

When you fasten the GPIB Cable with the two 7 mm standoff, set box torque wrench's torque to 8.7 in-lb.

Replacement Procedure
GPIB Cable Replacement

Figure 6-13 GPIB Removal

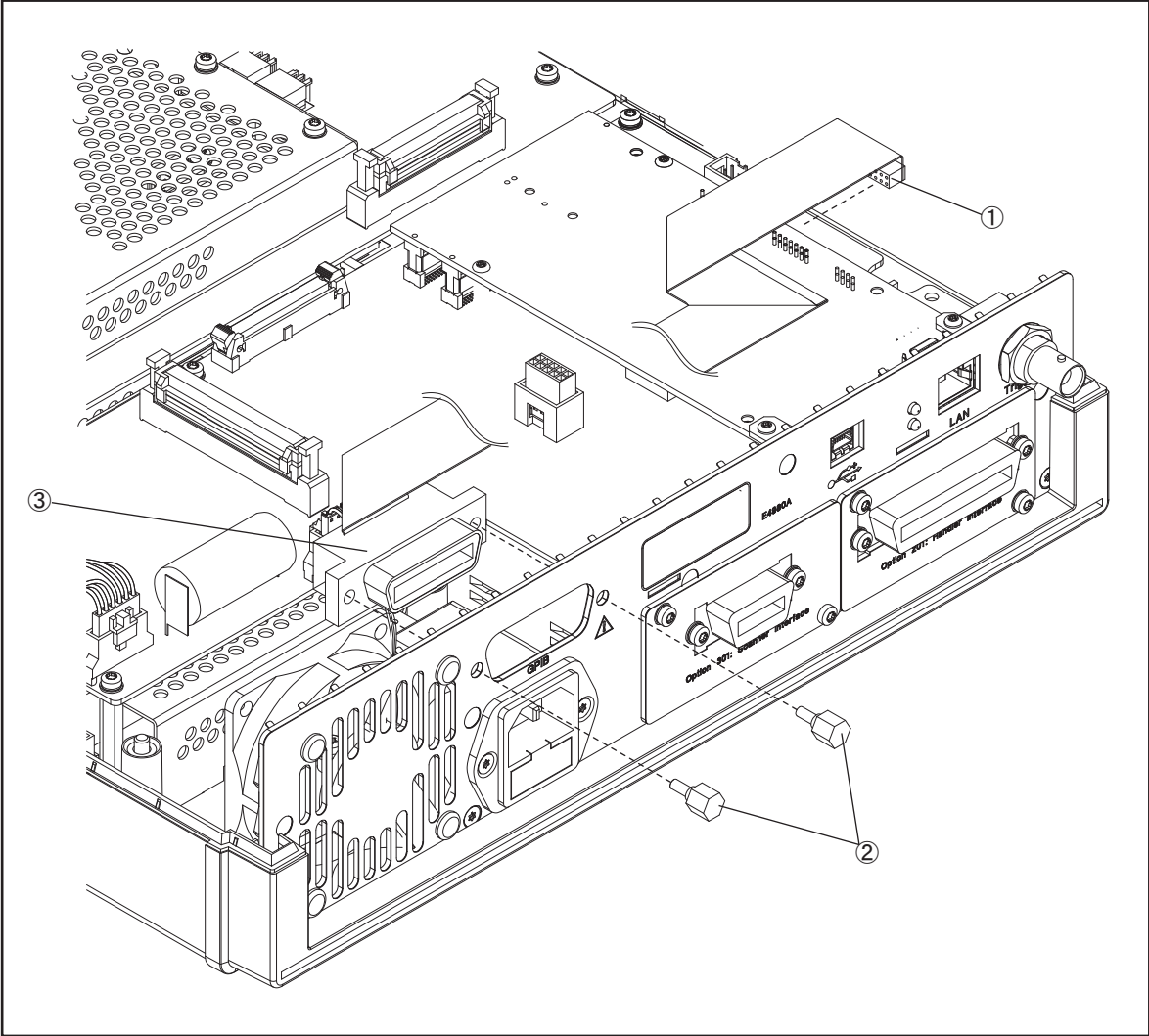

e4980ase1042

Power Inlet Assembly Replacement

Tools Required

- Torque screwdriver, TORX T20
- Torque screwdriver, TORX T8
- Torque screwdriver, TORX T10
- Box torque wrench, 5/8 inch

Removal Procedure

Refer to Figure 6-14 for this procedure.

- Step 1.** Remove the 3/4 Rack Module Top as described in “3/4 Rack Module Top Replacement” on page 90.
- Step 2.** Remove the PPMC PCA as described in “PPMC PCA Replacement” on page 101.
- Step 3.** Remove the A1 Mother Board as described in “A1 Mother Board Replacement” on page 103.
- Step 4.** Disconnect the power cable connector (item 1) from the Power Supply Assembly.
- Step 5.** Remove the TORX T20 screw (item 2) fastening the ground cable.
- Step 6.** Remove the two TORX T10 screws (item 3) fastening the Inlet Assembly.
- Step 7.** Remove the Inlet Assembly (item 4) from the Rear Panel.
- Step 8.** Detach the fuse box (item 5) from the original Inlet Assembly and remove the fuse (item 6).

Replacement Procedure

- Step 1.** Reverse the order of the removal procedure.

NOTE

When you fasten the ground cable with the TORX T20 screw, set screwdriver's torque to 21.1 in-lb.

When you fasten the Inlet Assembly with the two TORX T10 screws, set screwdriver's torque to 8.7 in-lb.

Do not forget to insert the fuse in the new Inlet Assembly.

Replacement Procedure
Power Inlet Assembly Replacement

Figure 6-14 POWER INLET Assembly Removal

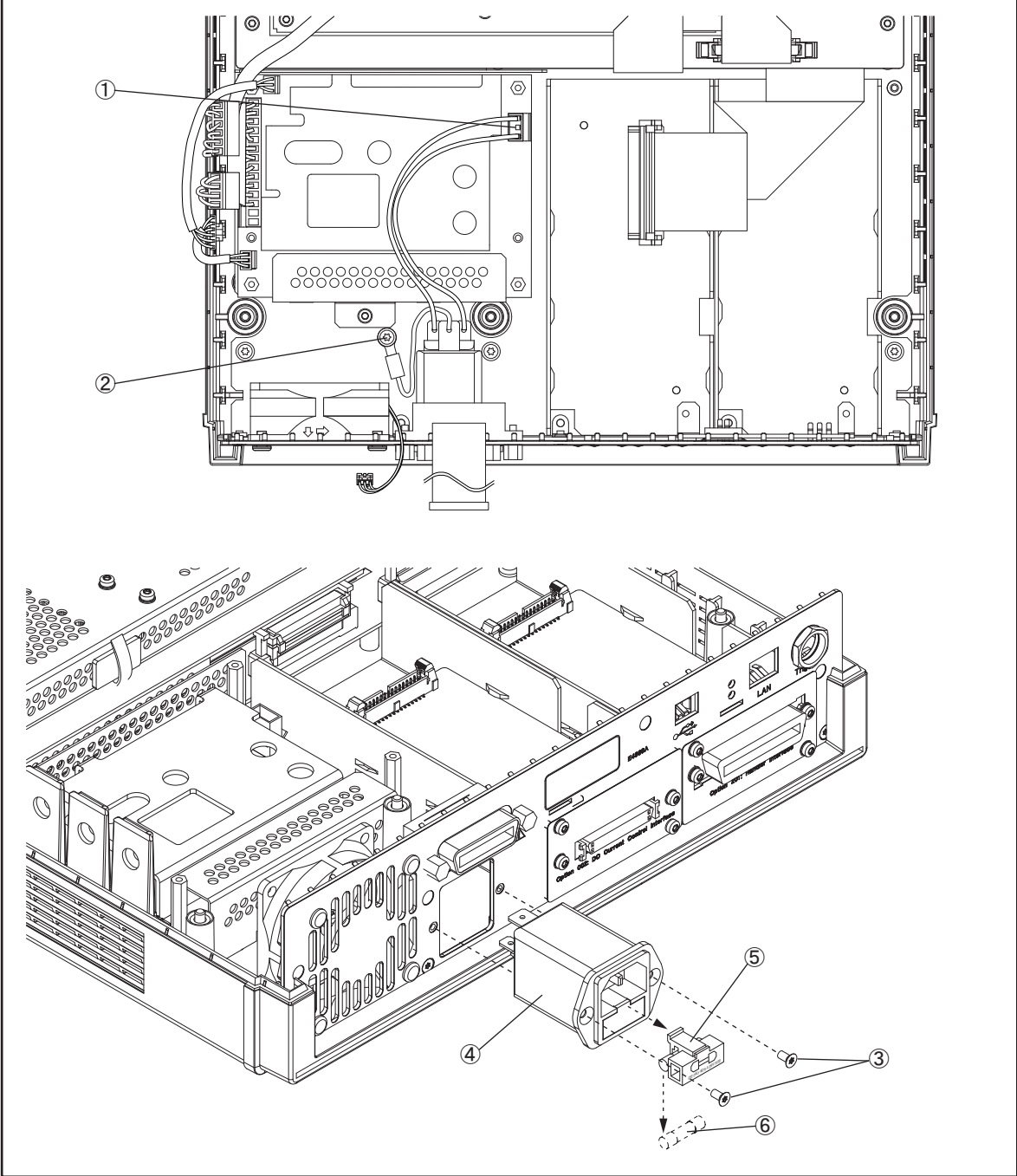

e4980ase1043

PCA E4980 USB Replacement

Tools Required

- Torque screwdriver, TORX T20

Removal Procedure

Refer to Figure 6-15 for this procedure.

- Step 1.** Remove the 3/4 Rack Module Top as described in “3/4 Rack Module Top Replacement” on page 90.
- Step 2.** Disconnect the Front USB Cable (item 1) from PCA E4980 USB.
- Step 3.** Remove the two TORX T20 screws (item 2) fastening the PCA E4980 USB and the ground cable.
- Step 4.** Remove the PCA E4980 USB (item 3) from the Front Panel Assembly.

Replacement Procedure

- Step 1.** Reverse the order of the removal procedure.

NOTE

When you fasten the PCA E4980 USB and the ground cable with the two TORX T20 screws, set screwdriver's torque to 14 in-lb.

Figure 6-15 PCA E4980 USB Removal

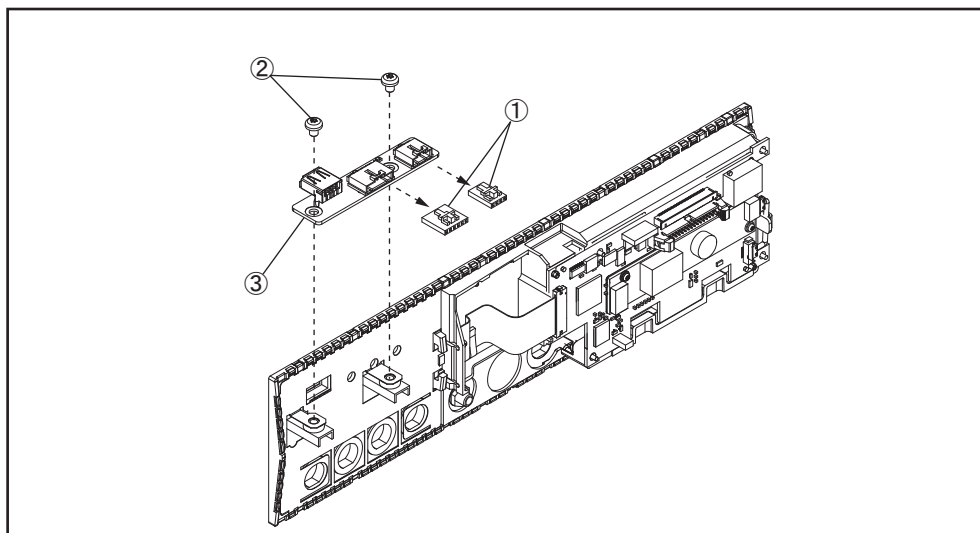

e4980ase1033

Binding Post Sgl Replacement

Tools Required

- Torque screwdriver, TORX T10
- Torque screwdriver, TORX T20
- Box torque wrench, 7 mm
- Box torque wrench, 5/8 inch
- Box torque wrench, 3/8 inch

Removal Procedure

Refer to Figure 6-16 for this procedure.

- Step 1.** Remove the 3/4 Rack Module Top as described in “3/4 Rack Module Top Replacement” on page 90.
- Step 2.** Remove the A3 Analog Daughter Board as described in “A3 Analog Daughter Board Replacement” on page 94.
- Step 3.** Remove the A2 Analog Board as described in “A2 Analog Board Replacement” on page 96.
- Step 4.** Remove the Front Panel as described in “Front Panel Assembly Removal” on page 98.
- Step 5.** Remove the 3/8 inch nut (item 1) and washer (item 2) fastening the Binding Post Sgl.
- Step 6.** Slide the Binding Post Sgl (item 3) from the Front Panel Assembly.

Replacement Procedure

- Step 1.** Reverse the order of the removal procedure.

NOTE

When you fasten the Binding Post Sgl with the 3/8 inch nut and washer, set box torque wrench's torque to 17.4 in-lb.

Figure 6-16 Binding Post Sgl Removal

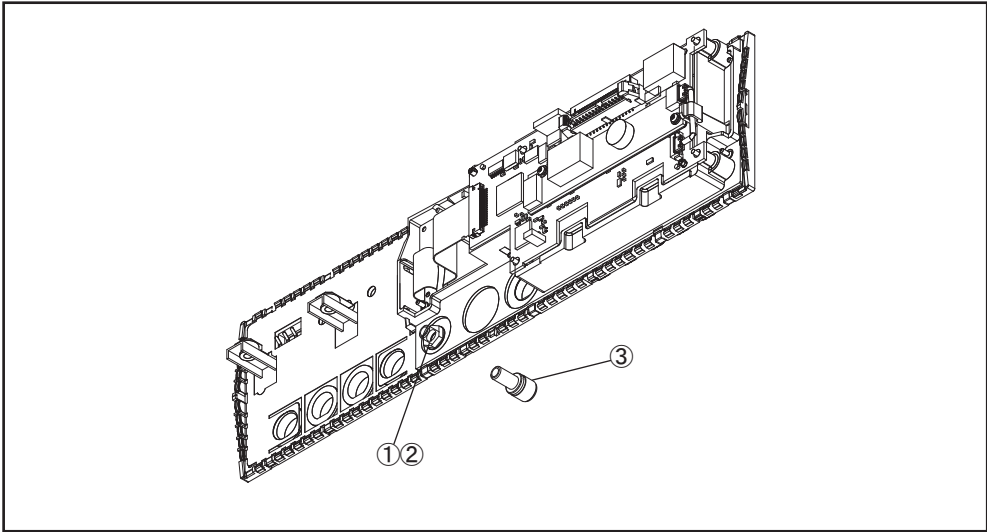

e4980ase1034

Inverter Replacement

Tools Required

- Torque screwdriver, TORX T10
- Torque screwdriver, TORX T20
- Torque screwdriver, TORX T6
- Box torque wrench, 7 mm
- Box torque wrench, 5/8 inch

Removal Procedure

Refer to Figure 6-17 for this procedure.

- Step 1.** Remove the 3/4 Rack Module Top as described in “3/4 Rack Module Top Replacement” on page 90.
- Step 2.** Remove the A3 Analog Daughter Board as described in “A3 Analog Daughter Board Replacement” on page 94.
- Step 3.** Remove the A2 Analog Board as described in “A2 Analog Board Replacement” on page 96.
- Step 4.** Remove the Front Panel Assembly as described in “Front Panel Assembly Removal” on page 98.
- Step 5.** Disconnect the display cable (item 1) from the Inverter.
- Step 6.** Release the Cable Assy from the clip (item 2) on the Front Panel Assembly.
- Step 7.** Disconnect the Cable Assy (item 3) from the Front Panel Assembly.
- Step 8.** Remove the two TORX T6 screws (item 4) fastening the Inverter and the insulator.
- Step 9.** Remove the Inverter (item 5) with the insulator (item 6) from the Front Panel Assembly. Then, remove the Inverter from the insulator.

Replacement Procedure

- Step 1.** Reverse the order of the removal procedure.

NOTE

When you fasten the Inverter and the insulator with the two TORX T6 screws, set screwdriver's torque to 3.05 in-lb.

Figure 6-17 Inverter Removal

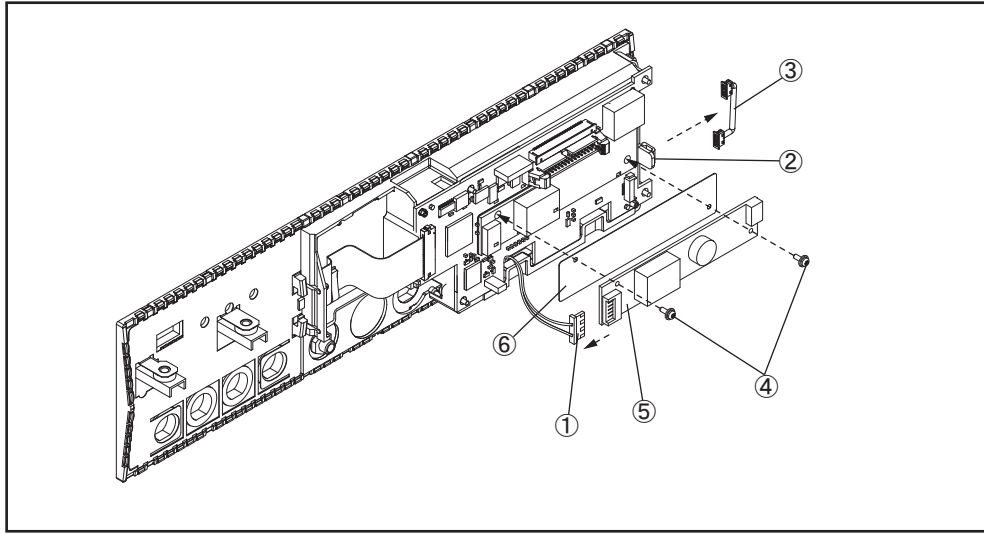

e4980ase1035

Front Panel, Key Pad, and Key Flex Circuit Replacement

Tools Required

- Torque screwdriver, TORX T10
- Torque screwdriver, TORX T20
- Box torque wrench, 7 mm
- Box torque wrench, 5/8 inch

Removal Procedure

Refer to Figure 6-18 for this procedure.

- Step 1.** Remove the 3/4 Rack Module Top as described in “3/4 Rack Module Top Replacement” on page 90.
- Step 2.** Remove the PCA E4980 USB as described in “PCA E4980 USB Replacement” on page 117.
- Step 3.** Remove the A3 Analog Daughter Board as described in “A3 Analog Daughter Board Replacement” on page 94.
- Step 4.** Remove the A2 Analog Board as described in “A2 Analog Board Replacement” on page 96.
- Step 5.** Remove the Front Panel Assembly as described in “Front Panel Assembly Removal” on page 98.
- Step 6.** Disconnect the Display Cable (item 1) from the Key Flex Circuit.
- Step 7.** Carefully remove the Display Support with the LCD display (item 2) from the Front Panel.

NOTE

When removing the Display Support, release the hook (flat cable side) of the Display Support first, and then carefully release the other hooks of the Display Support.

Be careful not to break the hooks.

- Step 8.** Remove the Front Panel (item 3) from the Key Pad (item 4), the Window EMI Shield (item 5), the Key Flex Circuit (item 6), and the EMI Shield (item 7).

Replacement Procedure

- Step 1.** Reverse the order of the removal procedure.

Figure 6-18 Front Panel, Key Pad, and Key Flex Circuit Removal

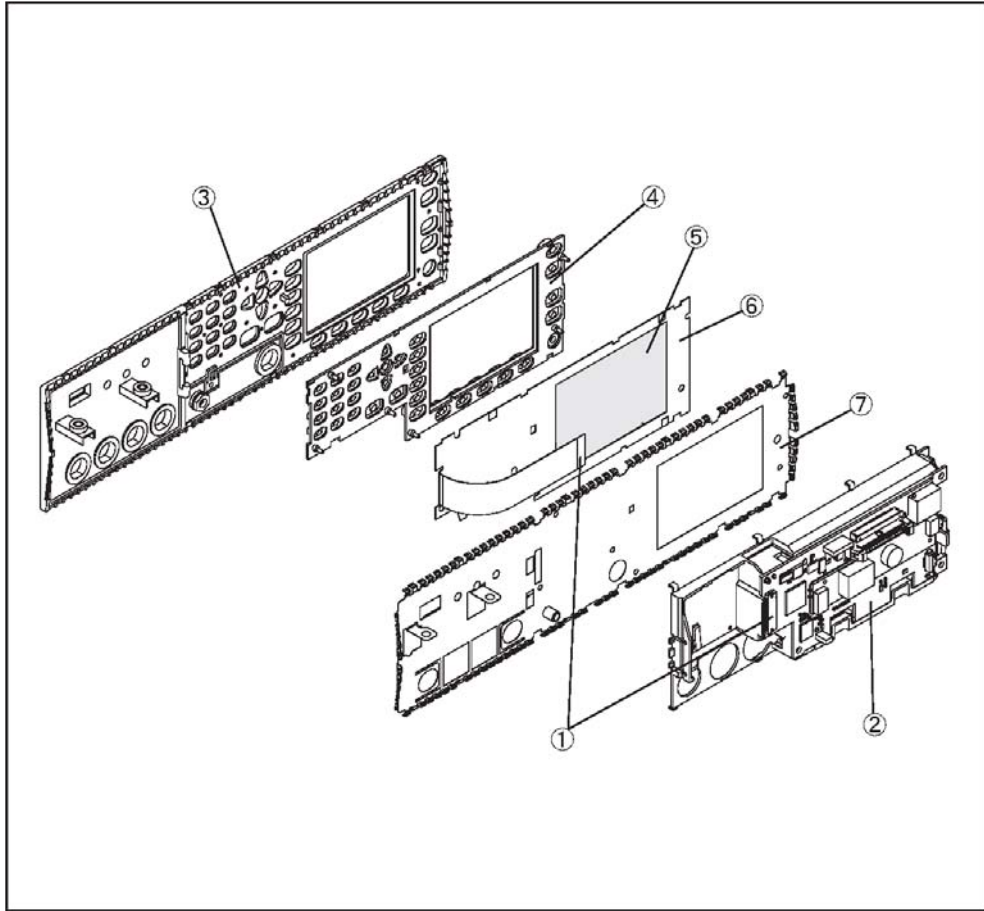

e4980ase1036

Display Interface Replacement

Tools Required

- Torque screwdriver, TORX T10
- Torque screwdriver, TORX T20
- Torque screwdriver, TORX T6
- Box torque wrench, 7 mm
- Box torque wrench, 5/8 inch

Removal Procedure

Refer to Figure 6-19 for this procedure.

- Step 1.** Remove the 3/4 Rack Module Top as described in “3/4 Rack Module Top Replacement” on page 90.
- Step 2.** Remove the PCA E4980 USB as described in “PCA E4980 USB Replacement” on page 117.
- Step 3.** Remove the A3 Analog Daughter Board as described in “A3 Analog Daughter Board Replacement” on page 94.
- Step 4.** Remove the A2 Analog Board as described in “A2 Analog Board Replacement” on page 96.
- Step 5.** Remove the Front Panel Assembly as described in “Front Panel Assembly Removal” on page 98.
- Step 6.** Remove the Inverter as described in “Inverter Replacement” on page 120.
- Step 7.** Remove the Front Panel, the Key Pad, and the Key Flex Circuit as described in “Front Panel, Key Pad, and Key Flex Circuit Replacement” on page 122.
- Step 8.** Remove the four TORX T6 screws (item 1) fastening the LCD Display.
- Step 9.** Remove the LCD Display (item 2) from the Display Support with the Display Interface.
- Step 10.** Carefully remove the Display Interface (item 3) from the Display Support (item 4).

Replacement Procedure

- Step 1.** Reverse the order of the removal procedure.

NOTE

When you fasten the LCD Display with the four TORX T6 screws, set screwdriver's torque to 3.05 in-lb.

When you replace the LCD Display with a new one, stick new gaskets (P/N : E4980-25003 × 2, E4980-25004 × 2) to surroundings on the LCD Display.

Figure 6-19 Display Interface Removal

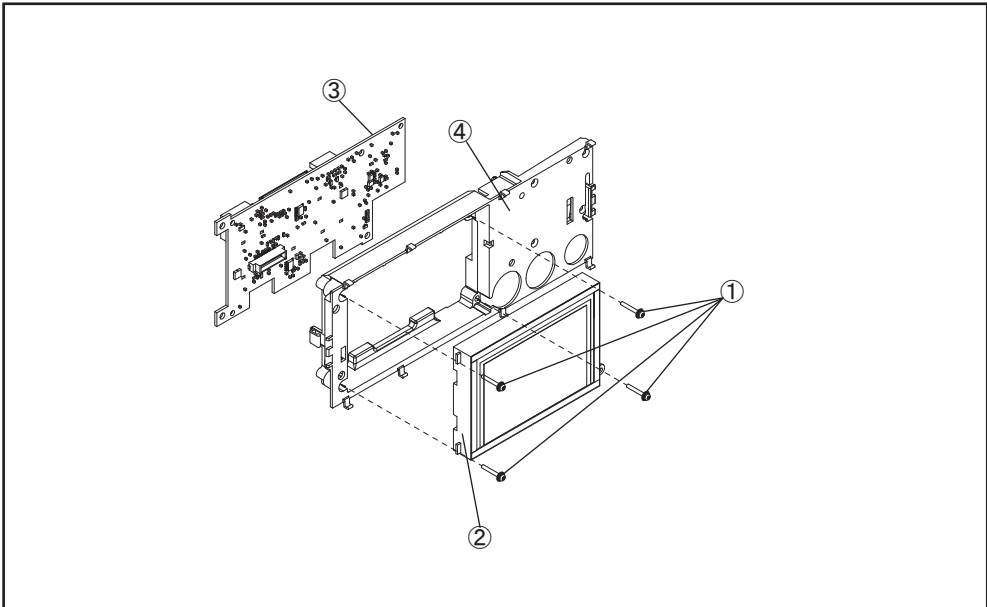

e4980ase1037

Replacement Procedure
Display Interface Replacement

7

Post-Repair Procedures

This chapter lists the procedures required to verify the E4980A operation after an assembly is replaced with a new one.

Post-Repair Procedures

Table 7-1 *Post Repair Procedures* lists the required procedures that must be performed after the replacement of an assembly. These are the recommended minimum procedures to ensure that the replacement is successfully completed.

Table 7-1 Post-Repair Procedures

Replaced Assembly or Part	Required Adjustments Correction Constants (CC)	Verification
P1001 INSTALLED OS (E4980-62004)	At first, it is required to install the latest firmware based on “Appendix B Firmware Update”. Perform the following required adjustments using “PPMC” in Spot Adjustment of the program. Power On Test Limit	Inspect the booting process, and power on test result.
A1 Mother Board	Perform the following required adjustments using “A1 Board” in Spot Adjustment of the program. Write ID	Inspect the booting process, and power on test result.
A2 Analog Board	Perform the following required adjustments using “A2 Board” in Spot Adjustment of the program. Write Null phase track default data Null DC offset Adjustment Null ADC DC offset Adjustment ADC Linearity Adjustment DC Bias Adjustment DC level V monitor Adjustment (for opt 001) DC level I monitor Adjustment (for opt 001) DC Source Adjustment (for opt 001) DCR Adjustment (for opt 001) Impedance Adjustment AC Level monitor Adjustment OSC Level Adjustment	Inspect the booting process, and power on test result. DC Bias V Level Monitor Accuracy Test (for opt 001) DC Bias I Level Monitor Accuracy Test (for opt 001) AC Signal Level Monitor Accuracy Test Impedance Measurement Accuracy Test DCR Measurement Accuracy Test (for opt 001)

Table 7-1 Post-Repair Procedures

Replaced Assembly or Part	Required Adjustments Correction Constants (CC)	Verification
A3 Analog Board	Perform the following required adjustments using “A3 Board” in Spot Adjustment of the program. DC Bias Adjustment DC level V monitor Adjustment (for opt 001) DC level I monitor Adjustment (for opt 001) DC Source Adjustment (for opt 001) DCR Adjustment (for opt 001) Impedance Adjustment AC Level monitor Adjustment OSC Level Adjustment	Inspect the booting process, and power on test result. Frequency Accuracy Test DC Source Level Monitor Accuracy Test (for opt 001) DC Bias Level Accuracy Test (for opt 001) AC Signal Level Accuracy Test Impedance Measurement Accuracy Test DCR Measurement Accuracy Test (for opt 001)
USB Board	No adjustment needed	Inspect the booting process, and power on test result. “To Check the Front USB port” on page 41
Power Supply	No adjustment needed	Inspect the booting process, and power on test result.
Fan Assembly	No adjustment needed	Inspect the booting process, and power on test result.
LCD Assembly	No adjustment needed	Inspect the booting process, and power on test result. “To Check the LCD” on page 41 DC Bias Level Accuracy Test (for opt 001)
Key Assembly	No adjustment needed	Inspect the booting process, and power on test result. “To Check the Front Panel” on page 41 DC Bias Level Accuracy Test (for opt 001)
Handler I/F (option 201)	No adjustment needed	Inspect the booting process, and power on test result. “To Check the Handler Interface Function (Option 201 only)” on page 45
Scanner I/F (option 301)	No adjustment needed	Inspect the booting process, and power on test result. “To Check the Scanner Interface Function (Option 301 only)” on page 49

Table 7-1 **Post-Repair Procedures**

Replaced Assembly or Part	Required Adjustments Correction Constants (CC)	Verification
Bias Current I/F (option 002)	No adjustment needed	Inspect the booting process, and power on test result. “To Check the Bias Current Interface Function (Option 002 only)” on page 53

A **Manual Changes**

This appendix contains the information required to adapt this manual to versions or configurations of the E4980A manufactured earlier than the current printing date of this manual. The information in this manual applies directly to E4980A units with the serial number that is printed on the title page of this manual.

Manual Changes

To adapt this manual to your E4980A, refer to Table A-1 and Table A-2.

Table A-1 Manual Changes by Serial Number

Serial Prefix or Number	Make Manual Changes

Table A-2 Manual Changes by Firmware Version

Version	Make Manual Changes

The ten-character serial number is stamped on the serial number plate (Figure A-1) on the rear panel.

Figure A-1 Serial Number Plate Example



e4980auj1003

B **Firmware Update**

This appendix describes how to update the E4980A firmware. When you want to update the E4980A firmware, refer to this appendix.

Update the E4980A firmware using USB/GPIB interface

Required Equipment

- E4980A.
- 82357A USB/GPIB interface.
- Personal Computer with I/O Libraries Suite (Windows 2000/XP).

How to update E4980A firmware using USB/GPIB interface

The following is the procedure to update the E4980A firmware using USB/GPIB interface.

- Step 1.** Connect the USB/GPIB interface from the USB terminal in your computer to the GPIB terminal in the E4980A rear panel. Then turn the E4980A on.
- Step 2.** Copy the following file from Agilent Technologies web site to the temporary work folder in your computer's HDD.
 - fw_upd.exe
- Step 3.** Execute the **Command Prompt** on your computer.
- Step 4.** Change the current folder to the temporary working folder with the "fw_upd.exe" file using **cd** command.
- Step 5.** Enter **fw_upd.exe GPIB0::17::INSTR** command to execute the firmware update program. The numerical value of "17" in the command is GPIB address of the E4980A. Then, press the Enter key.
- Step 6.** Wait a few minutes until the command prompt is displayed again.
- Step 7.** Press **System** key on the E4980A front panel to check the firmware revision.

Update the E4980A firmware using USB cable

Required Equipment

- E4980A.
- USB cable connecting the E4980A and external controller (with type A/4-prong male or type mini-B/5-prong male connectors depending on device used).
- Personal Computer with I/O Libraries Suite (Windows 2000/XP).

How to update E4980A firmware using USB cable

The following is the procedure to update the E4980A firmware using USB cable.

- Step 1.** Connect the USB cable from the USB terminal in your computer to the USB terminal in the E4980A rear panel. Then turn the E4980A on.
- Step 2.** Copy the following file from Agilent Technologies web site to the temporary work folder in your computer's HDD.
 - fw_upd.exe
- Step 3.** Execute the **Command Prompt** on your computer.
- Step 4.** Change the current folder to the temporary working folder with the "fw_upd.exe" file using **cd** command.
- Step 5.** Enter **fw_upd.exe USB0::2391::2313::MY12345678::0::INSTR** command to execute the firmware update program. The entered value of "2391::2313::MY12345678" in the command is USB ID of the E4980A, and the entered value of "MY12345678" is serial number of the E4980A. Then, press the Enter key.
- Step 6.** Wait a few minutes until the command prompt is displayed again.
- Step 7.** Press **System** key on the E4980A front panel to check the firmware revision.

Firmware Update
Update the E4980A firmware using USB cable

C **Power Requirement**

Replacing Fuse

Fuse Selection

Select proper fuse according to the Table C-1.

Table C-1 Fuse Selection

Fuse Rating/Type	Fuse Part Number
3A 250Vac UL/CSA type Time Delay	2110-1017

Setting up the fuse

Use the fuse that meets the following specifications.

UL/CSA type, Slo-Blo, 5x20mm miniature fuse, 3A 250V (part number: 2110-1017)

Spare fuses are available from Agilent Technologies sales office. To check or replace the fuse, disconnect the power cable and pull out the fuse holder (refer to Figure C-1) towards you (refer to Figure C-2).

Figure C-1

Fuse holder and power cable socket

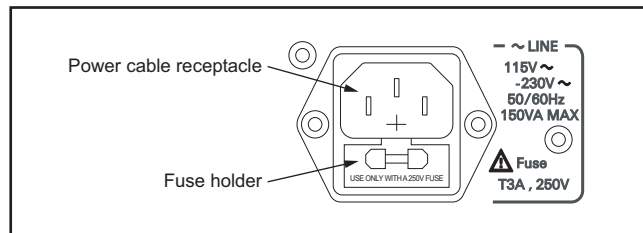

e4980ase1039

Figure C-2

Removing the fuse

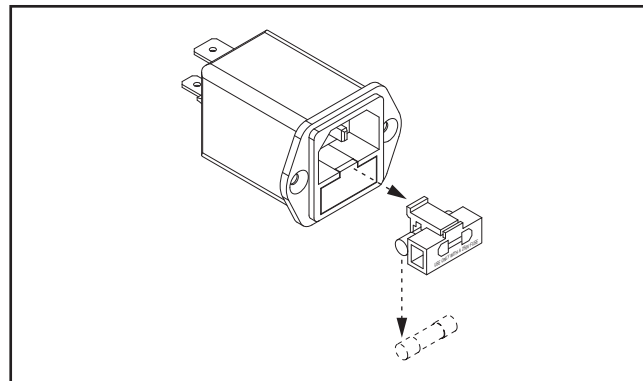

e4980ase1040

Power Requirements

The E4980A requires the following power source.

Voltage : 90 to 132 Vac, 198 to 264 Vac

Frequency : 47 to 63 Hz

Power : 150 VA maximum

Power Cable

In accordance with international safety standards, this instrument is equipped with a three-wire power cable. When connected to an appropriate ac power outlet, this cable grounds the instrument frame.



The type of power cable shipped with each instrument depends on the country of destination. Refer to Figure C-3 for the part numbers of the power cables available.

WARNING

For protection from electrical shock, the power cable ground must not be defeated. The power plug must be plugged into an outlet that provides a protective earth ground connection.

Power Requirement
Power Requirements

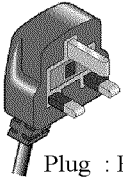
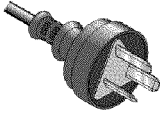
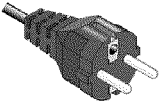
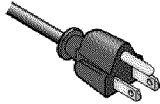
Figure C-3 Power Cable Supplied

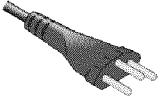
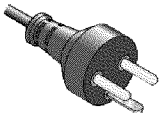
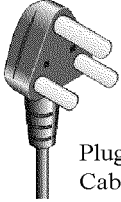
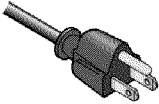
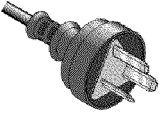
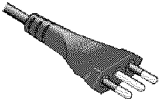
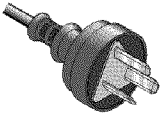
<p>OPTION 900</p>  <p>United Kingdom</p> <p>Plug : BS 1363/A, 250V, 10A Cable: 8120-1351</p>	<p>OPTION 901</p>  <p>Australia/ New Zealand</p> <p>Plug : AS 3112, 250V, 10A Cable: 8120-1369</p>
<p>OPTION 902</p>  <p>Continental Europe</p> <p>Plug : CEE 7 Standard Sheet VII, 250V, 10A Cable: 8120-1689</p>	<p>OPTION 903</p>  <p>U.S./ Canada</p> <p>Plug : NEMA 5-15P, 125V, 10A Cable: 8120-1378</p>
<p>OPTION 904</p>  <p>U.S./ Canada</p> <p>Plug : NEMA 6-15P, 250V, 6A Cable: 8120-0698</p>	<p>OPTION 906</p>  <p>Switzerland</p> <p>Plug : SEV Type 12, 250V, 10A Cable: 8120-2104</p>
<p>OPTION 912</p>  <p>Denmark</p> <p>Plug : SR 107-2-D, 250V, 10A Cable: 8120-2956</p>	<p>OPTION 917</p>  <p>India/ Republic of S.Africa</p> <p>Plug : IEC 83-B1, 250V, 10A Cable: 8120-4211</p>
<p>OPTION 918</p>  <p>Japan</p> <p>Plug : JIS C 8303, 125V, 12A Cable: 8120-4753</p>	<p>OPTION 920</p>  <p>Argentina</p> <p>Plug : Argentine Resolution 63, Annex IV, 250V, 10A Cable: 8120-6870</p>
<p>OPTION 921</p>  <p>Chile</p> <p>Plug : CEI 23-16, 250V, 10A Cable: 8120-6978</p>	<p>OPTION 922</p>  <p>China</p> <p>Plug : GB 1002, 250V, 10A Cable: 8120-8376</p>
<p>If you want to use a power cable other than the supplied one, contact your nearest Agilent sales office for information.</p>	

4287aoj005

D **Error Messages**

The Agilent E4980A provides error messages to indicate its operating status. This appendix describes the error messages of the E4980A in alphabetical order.

Error Messages

An error message is displayed in the instrument status display area in the lower-left part of the screen. Pressing the cursor arrow key on the front panel or executing the :DISP:CCL command clears the error message. Moreover, about a specific error message, when a sweep is started again, the display of an error message may disappear. Errors caused by operation of a front panel key simply appear on the display; with a few exceptions, these are not stored in the error queue.

The log of an error message, a maximum of 100 pieces are recorded, and it can go back and check from the oldest error. Executing the :SYST:ERR? command checks error logs. This operation can be performed only by "SCPI" command. It cannot be operated from the front panel.

An error with a positive error number is one uniquely defined for this instrument. On the other hand, an error with a negative error number is basically one defined for common GPIB devices in IEEE488.2.

A

1103

A1 EEPROM write error

An error is generated while writing data to A1 EEPROM. When this error occurs, contact Agilent Technology's Sales and Service Office or the company from which you bought the device.

B

62

Bias off, Turn bias on

DC bias sweep is performed with the DC BIAS function OFF.

-160

Block data error

Block data is improper.

-168

Block data not allowed

Block data is not allowed.

C

-140

Character data error

Character data is improper.

-148

Character data not allowed

Character data not allowed for this operation.

-144

Character data too long

Character data is too long (maximum length is 12 characters).

-100

Command Error

Improper command.

41

Correction measurement aborted

	Correction data measurement is aborted.
1201	CPU Bd EEPROM write error An error is generated while writing data to EEPROM. When this error occurs, contact Agilent Technology's Sales and Service Office or the company from which you bought the device.
1200	CPU Bd FLASH ROM write error An error is generated while writing data to FLASH. When this error occurs, contact Agilent Technology's Sales and Service Office or the company from which you bought the device.
29	Cycle power of 42841A and Preset The connection was not established with the 42841A. Cycle the power of the 42841A, then preset the E4980A.
	D
90	Data buffer overflow This error occurs when the amount of data exceeds the defined data buffer memory size. If this error occurs during the measurement after pressing [Save/Recall] - SAVE DATA - START LOG, press SAVE & STOP.
-230	Data corrupt or stale The setting file or correction data to be read cannot be read out with the current firmware version because the setting file or correction data is corrupt or old.
-222	Data out of range A data element (not violating the standard) outside the range defined by this instrument has been received. This error occurs, for example, when an integer-based command for which the parameter can be rounded exceeds the range of -2147483648 to +2147483647 or when a real-number-based command for which the parameter can be rounded exceeds the range of -9.9e37 to +9.9e37. This error also occurs when a numeric value other than a specified one is entered into a command in which the "BIN number" and "list table number" are specified as parameters and thus the parameters are not rounded.
-104	Data type error Improper data type used (for example, string data was expected, but numeric data was received).
26	DC bias I sink overload DC bias sink current is overloaded. When this error occurs, lower the value of the current setting.
25	DC bias I source overload DC bias source current is overloaded. When this error occurs, lower the value of the current setting
19	DC bias not available DC bias cannot be turned on in Rdc measurement.
18	DC bias opt not installed

Error Messages

Error number: 28

Operation that requires option 001 is performed in a model not having the power amp/DC bias option (option 001).

28 **DC bias unit connection changed**

The connection with the 42841A has been changed. Cycle the power of the 42841A, then preset the E4980A.

27 **DC bias unit disconnected**

The 42841A is not connected. Confirm the connection to the 42841A.

20 **DC bias unit powered down**

The 42841A is switched off. Turn on the switch.

63 **DC source off, Turn DC source on**

DC source sweep is performed with the DC source function OFF. Set the DC source function to ON.

E

10 **Exceeded AC+DC limit**

The amount of the voltage level exceeds 42V peak. Lower the DC voltage or AC voltage setting.

-200 **Execution error**

An error associated with execution has been generated for which this instrument cannot specify the error message. This code indicates that an error associated with execution defined in 11.5.1.1.5, IEEE488.2 has occurred.

-123 **Exponent too long**

The magnitude of the exponent was larger than 32000.

-178 **Expression data not allowed**

Expression data is not allowed.

-170 **Expression error**

Expression is improper.

F

1070 **Fan failed**

Cooling fan hardware failure is detected. When this error occurs, contact Agilent Technology's Sales and Service Office or the company from which you bought the device.

21 **Fixture circuit defective**

A fault has occurred in a circuit to absorb back-emf of the 42842A/B. Confirm the connection to the 42842A/B.

24 **Fixture cover open**

The protective cover of the 42842A/B is open. Close the cover.

23 **Fixture OPEN det. defective**

The opening and closing detection sensor of the 42842A/B protective cover detects an

error. When this error occurs, contact Agilent Technology's Sales and Service Office or the company from which you bought the device.

22

Fixture over temperature

The temperature inside the 42842A/B bias test fixture exceeds the limit. Turn off the DC bias and cool down the equipment.

30

Function type not available

The Ls-Rdc, Lp-Rdc and Vdc-Idc are not available when the 42841A is connected.

G

-105

GET not allowed

GET is not allowed inside a program message.

H

70

Handler I/F not installed

The handler interface function is set to ON in a model that does not have a handler interface board (option 201).

-114

Header Suffix out of Range

The header suffix is out of range.

I

73

I BIAS I/F not installed

The DC bias interface function is set to ON in a model that does not have the DC bias interface board (option 002).

-224

Illegal parameter value

The parameter value is not properly set. This error occurs, for example, when the :FUNC:IMP command is used to specify an Impedance-parameter that does not exist (as CPRS).

51

Inconsistent limit setting

For the comparator function, user attempts to set the threshold in the sequential mode by sending the COMP:SEQ:BIN command, although the tolerance mode is now selected. Select the sequential mode using COMP:MODE.

-161

Invalid block data

Invalid block data was received (for example, END received before length satisfied).

-101

Invalid character

Invalid character was received.

-141

Invalid character data

Bad character data or unrecognized character data was received.

-121

Invalid character in number

Invalid character in numeric data.

Error Messages

Error number: -171

- 171 **Invalid expression**
Invalid expression was received (for example, illegal character in expression).
- 103 **Invalid separator**
The message unit separator (for example, “;”, “;”) is improper.
- 151 **Invalid string data**
Invalid string data was received (for example, END received before close quote).
- 131 **Invalid suffix**
Units are unrecognized, or the units are not appropriate.
- M**
- 250 **Mass storage error**
An error occurred while accessing the USB memory. A USB memory-related error other than -257 error (File Name Error) occurred.
- 43 **Measurement failed**
A measurement error occurred during correction data measurement. The OPEN or SHORT state connected to the UNKNOWN terminals may be inappropriate.
- 109 **Missing parameter**
The number of parameters is less than that required for the command, or the parameter has not been entered. For example, the command “:CORR:USE” requires one more parameter. Therefore, when a message “:CORR:USE” is sent to a correct program message “:CORR:USE 11,” this instrument receives the former message as an invalid one because all parameters have not been entered. Enter command parameters correctly.
- N**
- 83 **No data to load**
There is no setup data for the selected number. Or the USB memory is not inserted.
- 60 **No values in sweep list**
List sweep measurement is performed when the measurement point is not set on the LIST SWEEP SETUP screen.
- 128 **Numeric data error**
Numeric data is improper.
- 128 **Numeric data not allowed**
Numeric data not allowed for this operation.
- O**
- 83 **Out of Memory**
The E4980A has insufficient memory to perform the requested operation.

P

-220

Parameter error

When a parameter-related error other than Errors -221 through -229 occur, this error message is displayed.

-108

Parameter not allowed

The number of parameters exceeds that required for the command. For instance, when a program message “:FORM:BORD NORM, ASC” is sent instead of a correct program message with a command “:FORM:BORD NORM”, which requires a parameter, the instrument receives the message that the number of parameters is invalid. See the command reference to confirm the required number of parameters.

1080

Power failed

Power unit hardware failure is detected. Contact Agilent Technology’s Sales and Service Office or the company from which you bought the device.

1000

Power on test failed

An error occurs during a self test at power-on. The E4980A may be faulty. Contact Agilent Technology’s Sales and Service Office or the company from which you bought the device.

A self test fails when an interface board is removed or not connected properly. Check the connection with a cable when you change the setting of the interface board.

-112

Program mnemonic too long

Program mnemonic is too long (maximum length is 12 characters).

Q

-350

Queue overflow

There is no room in the queue and an error occurred but was not recorded. Clear the error queue.

-430

Query DEADLOCKED

Input buffer and output buffer are full; cannot continue.

-400

Query error

Query is improper.

-410

Query INTERRUPTED

Query is followed by DAB or GET before the response is completed.

-420

Query UNTERMINATED

Addressed to talk, incomplete program message received.

-440

Query UNTERMINATED error after indefinite response

A query that requests arbitrary data response (*IDN? and *OPT? queries) is sent before normal queries in a program message (for example, FREQ?; *IDN? is expected, but *IDN?; FREQ? is received).

Error Messages
Error number: 16

R

16 **Reference Measurement aborted**
Reference data measurement is aborted.

S

71 **Scanner I/F not installed**
Operation that requires option 301 is performed in a model that does not have a scanner interface board (option 301).

82 **Store failed**
User attempts to save data into number 10 to 19 when a USB memory device is not inserted. Prepare the USB memory device or save data into number 0 to 9.

-150 **String data error**
String data is improper.

-158 **String data not allowed**
String data is not allowed.

-138 **Suffix not allowed**
A suffix is not allowed for this operation.

-102 **Syntax error**
Unrecognized command or data type was received.

T

-223 **Too many digits**
The received numeric value is too long (exceeds 255 digits).

-223 **Too much data**
The block-, expression-, or character-string-type program data that are received conform with the standard but exceed the amount that can be processed under the condition of the memory or conditions specific to memory-related devices. In this instrument, this error occurs when the number of characters exceeds 254 in a character-string parameter.

-211 **Trigger ignored**
The instrument receives and detects a trigger command (“:TRIG”) or an external trigger signal, but it is ignored due to the timing condition (the instrument is not in the wait-for-trigger state, for example). Change the setup so that a trigger command or an external trigger signal can be sent after the instrument has entered the wait-for- trigger state.

U

-113 **Undefined header**
A command not defined in this instrument, though not illegal in the syntactic structure, has been received. For example, when the message “:OUTP:DC:ISOL:FREQ:AUTO ON” is sent instead of the correct program message “:OUTP:DC:ISOL:LEV:AUTO ON” the message sent is received as an undefined command by this instrument. See the command

reference and use the correct command.

V

14

V bias disabled

The DC voltage bias is set when the 42841A is connected. Set the DC current bias or disconnect the 42841A.

45

Valid in single mode only

SINGLE channel correction data is measured when the MULTI channel correction mode is set.

Warning Message

A warning message is displayed in the instrument status display area in the lower-left part of the display. Pressing any of the front panel keys or executing the :DISP:CCL command clears the message.

This message simply appears on the display since it is not known to remote environments such as GPIB. This message is not displayed when another error message has been already displayed in the instrument message/warning area.

The warning messages for this instrument are as follows.

Numeric

1 I bias unit

The E4980A finds one current bias unit (42841A) connected.

2 I bias units

The E4980A finds two current bias units (42841A) connected.

A

ALC unable to regulate

The voltage level setting is inappropriate for using the ALC function. The ALC function does not work and the operation will be the same as when the ALC function is turned off. The measurement data status is set to 4. Refer to E4980A User's Guide.

C

Clear the table first

This error occurs when the value of MODE has been changed when the LIMIT TABLE SETUP screen is moved to another screen or the sweep parameter on the LIST SWEEP SETUP screen is changed even though a sweep list for another measurement parameter exists. Clear the table first.

Correction, not effective

The correction function does not work because the MULTI correction mode is used but the test frequency is not equal to the spot frequency.

I

Improper high/low limits

The upper limit value is less than the lower limit value. Set the lower limit value to less than the upper limit value.

Incompatible state file

The setting file recalled from a USB memory device has been saved using an E4980A with a different firmware version or different options. There may be some parameters set up incorrectly. Check the setting.

S

Signal source overload

The signal source is overloaded. The measurement data is not guaranteed to be valid. The measurement result data status of the measurement result output is set to 3.

When measuring Ls-Rdc/Lp-Rdc, set both RANGE and DCR RNG properly, or “OVERLOAD” will be displayed.

Signal source overvoltage

The signal source voltage exceeds its limit. Lower the voltage setting of the signal source.

Error Messages
Error number: 45