



Precision Integrating
Sound Level Meter

Type 2236 A-007

Type 2236 B-007

Type 2236 C-007

Type 2236 D-007

With software version 2.1 or higher

October 1996

Trademarks

IBM is a registered trademark of International Business Machines Inc., USA

Copyright © 1993, 1996, Brüel & Kjær Sound & Vibration Measurement A/S

All rights reserved. No part of this publication may be reproduced or distributed in any form, or by any means, without prior consent in writing from Brüel & Kjær Sound & Vibration Measurement A/S, Nærum, Denmark.

Chapter 1

Useful Information

1.1	About this Manual	1-2
1.2	About the Type 2236 Sound Level Meter	1-2
	Parameters	1-2
	Settings	1-3
	Data Operations	1-7
	Memory	1-8
1.3	Practical Hints	1-10

1.1 About this Manual

Figures are used to guide you through using the pushkeys. Please note the following when using the figures:

n × Press this pushkey *n* times

OK Press this to save any changes made in connection with the Settings or **(Data)** pushkeys

NO Press this to return to the screen indicated without saving any changes made

1.2 About the Type 2236 Sound Level Meter

1.2.1 Parameters

Precision Integrating Sound Level Meter Type 2236 is a Type 1 sound level meter complying with ANSIS 1.4–1983 and Draft S1.43, 6th Sept., 1992, and IEC 651 (1979) and 804 (1985). It can measure the following parameters:

- **MaxL**: maximum SPL since the last reset
- **MinL**: minimum SPL since the last reset
- **MaxP**: maximum Peak level since the last reset
- **Peak**: maximum Peak level in 1s interval
- **SPL**: maximum RMS level in 1s interval (according to IEC 651)
- **Leq**: equivalent continuous sound level (L_{eq} according to IEC 804)
- **LIm**: equivalent continuous impulse sound level (if time weighting is I) (L_{Im} according to IEC 804, Appendix B)
- **LAV4**: equivalent continuous sound level with Exchange Rate of 4dB ($L_{AV,4}$ according to ANSIS 1.25, L_{DOD})*

* Not available with I time weighting

Chapter 1—Useful Information About the Type 2236 Sound Level Meter

- LAV5: equivalent continuous sound level with Exchange Rate of 5dB ($L_{AV,5}$ according to ANSIS 1.25, L_{OSHA})*
- SEL: Sound Exposure Level (if A-weighted, then = L_{EA} , according to IEC 804)
- IEL: Impulse Sound Exposure Level (if time weighting is I)
- LEPd: Daily Personal Noise Exposure Level (see section 8.3)†
- LN(3) (default L_{90}): RMS level exceeded $N_3\%$ of the measurement time (L_{N3})**
- LN(2) (default L_{50}): RMS level exceeded $N_2\%$ of the measurement time (L_{N2})**
- LN(1) (default L_{10}): RMS level exceeded $N_1\%$ of the measurement time (L_{N1})**
- Ov1: Input signal overloading instrument (% of the measurement time)

In addition, Precision Integrating Sound Level Meter Types 2236 C-007 and 2236 D-007 contain $1/1$ -octave filter sets between 31.5Hz and 8kHz which comply with ANSIS 1.11-1986 and IEC 225 (1966). They can measure all the above-mentioned parameters in each of the filter bands.

1.2.2 Settings

Checking and Changing the Settings

The sound level meter's Settings are additional to the basic measurement set-up. They are very useful and are based on a very simple principle (see the example in Fig. 1.1). There are twelve of them in all:

- Auto Logging
- Calibration
- Peak Weighting

* Not available with I time weighting

† Not available with I time weighting or Exchange Rate of 4 or 5dB

** Not available with I time weighting

- Exchange Rate
- Date and Time
- Auto Start
- Change Range Reset
- Contrast
- Percentiles
- Exposure Time
- Interface
- Output Formats

Checking

You can check the first of the sound level meter's Settings by pressing **<Show>**. You can then step through them by pressing **<Show>**. However, the Settings are cyclic and you can step forwards and backwards through them using **Parameter <▲>** and **<▼>**, respectively (see Fig. 1.1).

Changing

When you reach a Setting you want to change, press **<Edit>**. A cursor (**▶**) appears on the first set-up line you can change. If there are other set-up lines on the screen, you can move the cursor to them using **Level <▲>** and **<▼>**.

When the cursor is on the set-up line of the Setting you want to change, press **Parameter <▲>** and **<▼>** to step through the available parameters. You can also step through them by pressing **<Edit>** (see Fig. 1.1).

When you have the set-up you desire for that Setting, press **<OK>** to save the changes and check the changed Setting. An accept cursor (**■▶**) briefly replaces the edit cursor (**▶**) to show that the sound level meter has accepted the change.

If you change a Setting by mistake, press **<NO>** instead of **<OK>** to revert to its previous set-up.

Fig. 1.2 shows an overview of the available Settings.

Chapter 1 – Useful Information About the Type 2236 Sound Level Meter

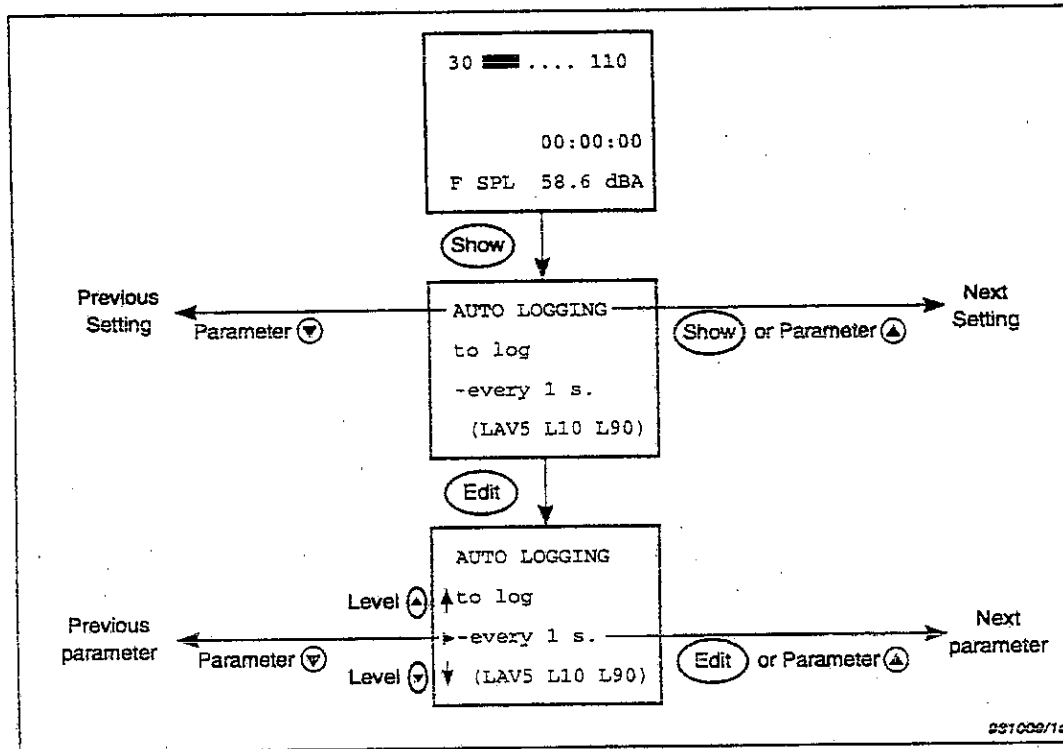

Fig.1.1 Principle of checking and changing the sound level meter's Settings

Fast Edit

In addition to the normal way of changing the set-up of a Setting (that is, by pressing **<Show>**, stepping through to the desired Setting and pressing **<Edit>**), you can also use two pushkeys together to “fast edit” a Setting (that is, go directly to a Setting with the edit cursor).

If you press **<Edit>**, and with 3 seconds, the pushkey indicated in Table 1.1, the selected Setting appears with the edit cursor (▶). You can now check and change the set-up of the Setting as described earlier in this section. When you have finished changing the Setting, pressing **<NO>** or **<OK>**, however, returns you to the main screen.

Chapter 1 – Useful Information About the Type 2236 Sound Level Meter





Fast Edit Pushkey (Edit +) Goes to Setting
Level ▲ or ▼ Parameter ▲ or ▼ (Disp. param.: Peak, MaxP) Parameter ▲ or ▼ (Disp. param.: L_{eq} , $L_{AV,4}$, $L_{AV,5}$) Parameter ▲ or ▼ (Disp. param.: L_N) Parameter ▲ or ▼ (Disp. param.: $L_{EP,d}$) Data     OK	Calibration Peak Frequency Weighting Exchange Rate Percentiles Exposure Time Output Formats Change Range with Reset Contrast Auto Start Status (only via Fast Edit)

Table 1.1 Fast edit pushkeys and the Settings accessed. Where display parameters are shown in parenthesis (for example, (Disp. param.: L_N)), then the display must be showing the indicated parameter (in this example, L_N) when the Fast Edit keys are pressed to go to the indicated setting (in this example, Percentiles).

1.2.3 Data Operations

The sound level meter's **Data** pushkey allows you to print your measurement results (data) and control the sound level meter's memory. It operates on a similar principle as Settings (see section 1.2.2) except that you press **Data** instead of **Show**. In addition, the sound level meter returns to the main screen after you have accepted changes to the selected operation. There are four data operations, each with its own screen:

- Print
- Store
- Recall
- Erase

Fig. 1.3 shows an overview of the data operations.

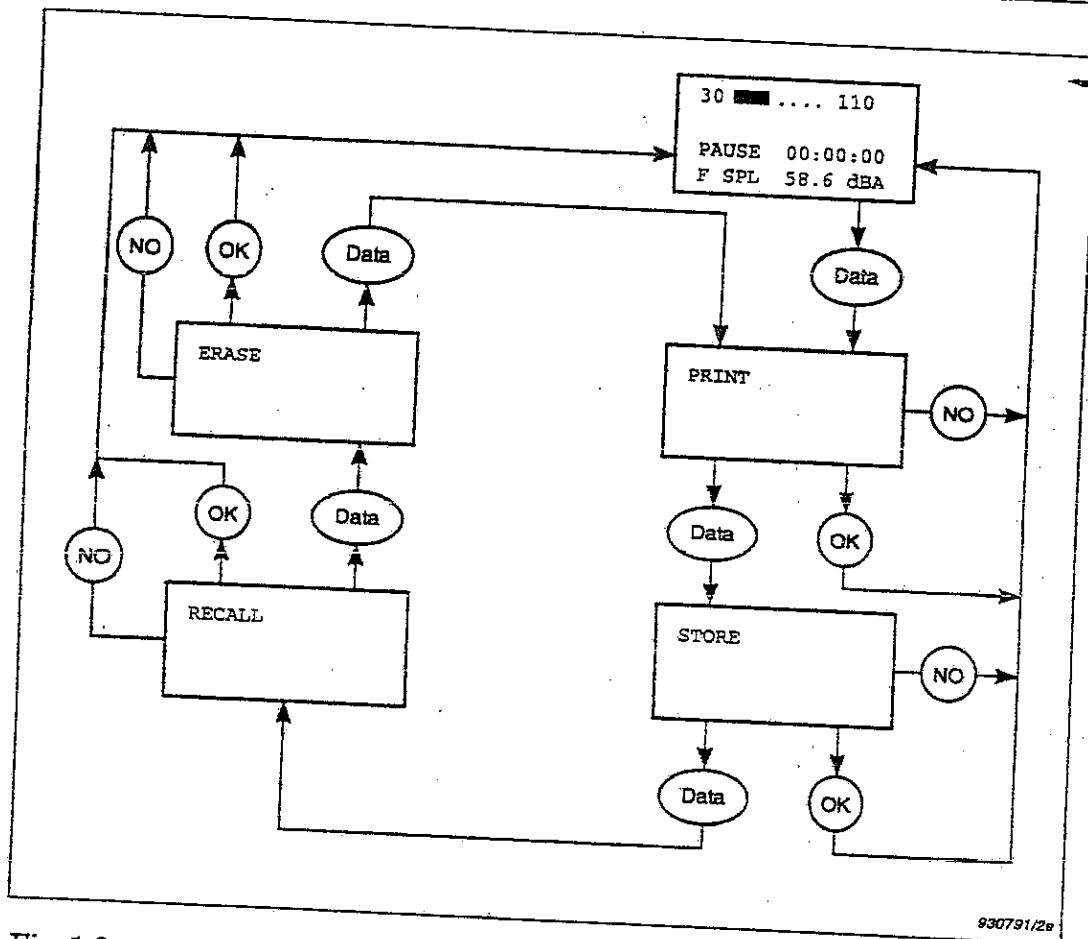

Fig. 1.3 An overview of the data operations available via the Data push-key

1.2.4 Memory

The sound level meter has three types of memory:

- Buffer
- Log
- Memory

Buffer

Contains the set-up and all results for the current measurement (i.e. since the last reset) – see section 1.2.1. From these,

Chapter 1 – Useful Information About the Type 2236 Sound Level Meter

the cumulative and level distributions and the Overall Results are calculated. The buffer is updated once a second.

Log

Contains the automatically Logged Results (see section 5.5.2):

- L_{eq} ($L_{AV,4}$ or $L_{AV,5}$ when the Exchange Rate is 4 or 5dB, respectively)
- L_{10}
- L_{90}
- measurement time of results (if logging interval is not 0.1 s)

Precision Integrating Sound Level Meter Types 2236 A-007 and C-007 can contain up to 21600 sets of results (i.e. up to 64800 results with their measurement times). This is enough to log, for example, 6 hours of $L_{AV,5}$, L_{10} and L_{90} values logged every second.

Precision Integrating Sound Level Meter Types 2236 B-007 and D-007 can contain up to 86400 sets of results (i.e. up to 259200 results with their measurement times). This is enough to log, for example, 24 hours of $L_{AV,5}$, L_{10} and L_{90} values logged every second.

Memory

Contains the Overall Results which you have manually stored in a Record together with the set-up. Can contain up to 40 Records.

Overall Results consist of:

- MaxL
- MinL
- MaxP
- L_{eq} (or $L_{AV,4}$, $L_{AV,5}$ or L_{Im})
- SEL (or IEL)
- $L_{EP,d}$
- Exposure Time
- Ovl
- L_{N1} (default L_{10})
- L_{N2} (default L_{50})
- L_{N3} (default L_{90})
- Frequency weighting of RMS signal
- Frequency weighting of Peak signal
- Time weighting
- Measurement range
- Elapsed measurement time
- Start date and time of measurement
- Number of pauses during measurement

Note: The three L_{Ns} in Overall Results are fixed as the selected L_{Ns} when the results were stored. You can, therefore, only see these three L_N values after recalling Overall Results.

1.3 Practical Hints

The sound level meter is designed as a self-contained unit to meet the requirements given in IEC 651 and similar national standards. However, some of the requirements given in the standards are based on measurements of pure tones under free field conditions. Practical measurements under similar conditions require the following extra precautions:

- do not stand close to the sound level meter
- do not use a windscreen or protective cover
- using a microphone extension cable, increase the distance between the microphone and any objects which can cause disturbances

The influence of your presence on the measurement can easily be checked by changing the distance between you and the

Chapter 1 - Useful Information

Practical Hints

microphone and observing the change in the measured sound pressure level. If your position influences the measurement result, then use a microphone extension cable or spatially average your measurements (that is, measure at several different positions and average the results). Note that, when dealing with pure tones, a small change in the position of the microphone can influence the result just as much as your physical presence.

Fortunately, the combination of free sound field and pure tones is very rare. With sound coming from several directions and as you are measuring over a broad frequency band, the influence of the sound level meter's housing, tripod and user becomes insignificant, and the above precautions need not be taken.

Figs. 6.8 and 6.9 show the influence of Tripod UA 0801 and Protective Cover UA 1236 under free field conditions and with pure tones.

Chapter 1 – Useful Information
Practical Hints

Chapter 2

An Example Measurement

2.1	Introduction	2-2
2.2	Making a Measurement	2-2

2.1 Introduction

This chapter guides you through the basic functions of the sound level meter by instructing you on how to make a noise measurement in a free sound field according to ISO 1996. You can find further information on the various steps in the relevant sections of the User Manual.

It is a good idea to have the fold out back cover open so that you have an annotated illustration of the sound level meter in front of you while you follow the example measurement.

We have assumed that the sound level meter is switched off and has not been used before following these instructions. If it has, ensure that you are using the default set-up (see section 3.3) before following the steps below.

We have also assumed that you will calibrate the sound level meter with Sound Level Calibrator Type 4231 and that you will print out your results using Serial Printer WQ 1138.

2.2 Making a Measurement

Switching On

1. Press ①.

The sound level meter switches on. After a self-test, the sound level meter is set up in Pause mode in the default set-up. The quasi-analogue scale shows the input signal to the preamplifier and the displayed parameter shows the current SPL. The buffer, log and memory are empty.

Since the displayed parameter (SPL) is an RMS parameter, you can see the frequency weighting of the RMS signal (shown in the bottom right-hand corner of the screen). See the fold out back cover for more details of the main screen.

Calibrating the Sound Level Meter

2. Press **Show**.

The screen shows the default Auto Logging screen.

3. Press **Parameter** **▲**.

The screen changes to the Calibration screen. The current calibration factor is shown.

4. Press **Edit**.

The screen shows the calibration set-up (see Fig. 2.1).

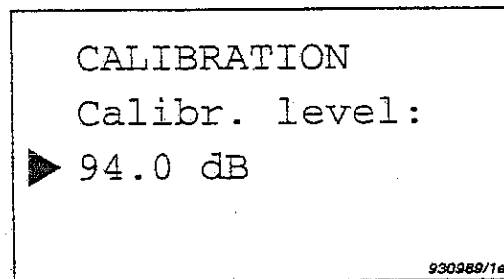

Fig. 2.1 The calibration set-up screen

5. Read the correct calibration level from the calibrator's calibration chart and use **Parameter** **▲** and **▼** to set the sound level meter to this level.*
6. Fit the calibrator onto the sound level meter and rest the sound level meter on a table or other flat surface. Ensure that the calibrator fits snugly on the microphone.
7. Switch on the calibrator.
The calibrator emits the 1kHz calibration signal.
8. Press **OK**.

* Sound Level Calibrator Type 4231 provides a nominal calibration signal of 94dB at 1 kHz. However, each calibrator is slightly different. It is, therefore, important to set the calibration level to the one given on the calibration chart for the calibrator used.

The sound level meter checks the calibration signal against the calibration level you set in step 5. It then asks if you want to calibrate according to the expected level.

9. Press **<OK>**.

The sound level meter calibrates itself according to the calibration level you set in step 5 and returns to the Calibration screen. The new calibration factor is shown.

10. Press **<OK>**.

The sound level meter returns to the main screen.

Checking the Weightings

11. With sound level meters without filter sets (Types 2236 A-007 and 2236 B-007), press **<Frequency Wt.>** three times.

The frequency weighting of the RMS signal (displayed in the bottom right-hand corner of the screen) changes through the three available weightings.

12. With sound level meters with filter sets (Types 2236 C-007 and 2236 D-007), press **<Frequency Wt.>** twelve times.

The frequency weighting of the RMS signal (displayed in the bottom right-hand corner of the screen) changes through the three available total weightings and the nine available octave filters (displayed at the left-hand side of the screen under the quasi-analogue scale). It then returns to the original frequency weighting of the RMS signal.

13. Press **<F/S/I>** three times.

The time weighting displayed in the bottom left-hand corner of the screen changes through the three available weightings.

Setting up the Sound Level Meter to Log

14. Press **<Show>**.

The screen shows the default Auto Logging screen (see Fig. 2.2). You can see that the sound level meter is set up so that it doesn't store Logged Results in its log.

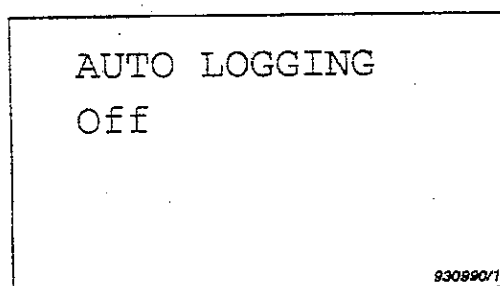

Fig. 2.2 The default Auto Logging set-up screen

15. Press **<Edit>**.

You can now set up the sound level meter to automatically store Logged Results in its log.

16. Press **Parameter <▲>**.

The screen changes to the Auto Logging set-up screen shown in Fig. 2.3. You can see that the sound level meter is set up to automatically store Logged Results ($L_{AV,5}$, L_{10} and L_{90}) in its log every 1s.

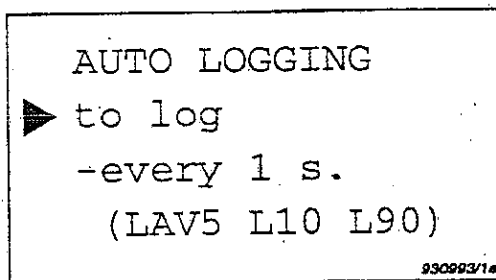

Fig. 2.3 One of the Auto Logging set-up screens

17. Press **<OK>** twice.

The sound level meter returns to the main screen.

You are now ready to start an A-weighted measurement of noise with a FAST time weighting. $L_{AV,5}$, L_{10} and L_{90} will be automatically logged into the sound level meter's log.

Measuring

18. Select an appropriate measurement range using **Level** **<▲>** or **<▼>**.

An appropriate measurement range is when the signal remains on the quasi-analogue scale at all times and no overload (indicated by + in the upper right-hand corner of the screen) occurs.

Note: It is important to select an appropriate measurement range before starting to measure as, if you change the range, either the sound level meter will reset, or the distributions and L_{Ns} will not be available.

19. Press **⊖**.

This clears the sound level meter's buffer of results and sets the elapsed time to zero.

20. Press **⊘**.

The sound level meter starts measuring. The timer on the right-hand side of the screen starts counting the elapsed measurement time. The A-weighted SPL is shown at the bottom of the screen. After each second, $L_{AV,5}$, L_{10} and L_{90} are transferred to the sound level meter's log.

21. Use **Parameter** **<▲>** or **<▼>** to look at the various parameters available.

The quasi-analogue scale always shows the SPL, regardless of the selected parameter. Note that, when a Peak parameter is selected, the frequency weighting of the Peak signal is shown. Note also that, when changing the parameter, the sound level meter does not reset.

22. After a few minutes, press $\text{\textcircled{2}}$.

The sound level meter stops measuring and logging. The timer shows the total measurement time.

Checking the Sound Level Meter's Calibration

23. Press **<Show>**.

The screen shows the default Auto Logging screen.

24. Press **Parameter <▲>**.

The screen changes to the Calibration screen.

25. Press **<Edit>**.

The screen shows the calibration set-up from before the measurement.

26. Fit the calibrator onto the sound level meter and rest the sound level meter on a table or other flat surface. Ensure that the calibrator fits snugly on the microphone.

27. Switch on the calibrator.

The calibrator emits the 1kHz calibration signal.

28. Press **<OK>**.

The sound level meter checks the calibration signal against the calibration level you set in step 5. They should be the same. If they are not, note the difference for inclusion in your measurement report.

29. Press **<NO>** twice.

The sound level meter returns to the Calibration screen and then to the main screen without being recalibrated.

Storing Results in the Sound Level Meter's Memory

30. Press **<Data>**.

The first Data screen (Print Set-up) appears.

31. Press **Parameter** (▲).

The Store Set-up screen (see Fig. 2.4) appears.

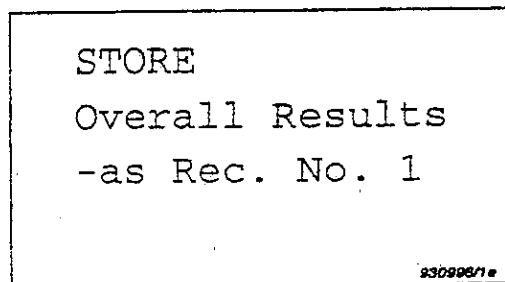

Fig. 2.4 The Store Set-up screen

32. Press (OK).

The Overall Results of the measurement you have just made are stored as Record No. 1 in the sound level meter's memory.

Printing out Overall Results

Warning! When connecting the sound level meter to the printer, ensure that both the printer and the sound level meter are switched off. Otherwise the instruments could be damaged.

33. Switch the sound level meter off. Connect it to Serial Printer WQ 1138 via the **Serial Interface** socket on the base of the sound level meter using 9-pole Cable with 25-pole Adaptor AO 1386.

34. Switch the sound level meter on.

35. Hold down the printer's (On Line) pushkey and switch the printer on.

The printer prints its set-up.

36. Ensure that the printer's baud rate is 9600 (see the printer's instruction manual for details on how to change its baud rate).

Chapter 2 – An Example Measurement Making a Measurement

The sound level meter is set, by default, to output the overall results with a short heading at a baud rate of 9600. To get a print-out, the printer and the sound level meter must have the same baud rate.

37. Press **<Data>**.

The Print Set-up screen appears (see Fig. 2.5).

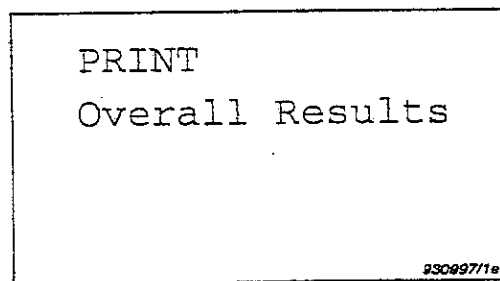

Fig. 2.5 The default Print Set-up screen

38. Press **<OK>**.

The printer prints the Overall Results (see section 1.2.4) together with a short heading containing the measurement set-up (the frequency weightings of the RMS and Peak signals, the time weighting and the measurement range). After transferring the results to the printer, the sound level meter displays the main screen.

Chapter 2—An Example Measurement
Making a Measurement

Chapter 3

Setting Up the SLM for Measurement

3.1	Mounting the Microphone	3-3
3.2	Fitting Batteries	3-4
	Replacing Batteries	3-4
	Using an External Power Supply	3-6
	The Back-up Battery	3-6
3.3	Switching the SLM On and Off.....	3-7
3.4	Setting the Measurement Range	3-8
3.5	Setting the Time Weighting	3-10
3.6	Setting the Frequency Weighting.....	3-11
	Introduction	3-11
	Setting the RMS Frequency Weighting	3-11
	Setting the Peak Frequency Weighting	3-13

3.7	Setting the Percentiles	3-14
3.8	Setting the Exchange Rate	3-16
3.9	Setting the Exposure Time	3-17
3.10	Setting the Date and Time	3-19
3.11	Setting the SLM to Change Range without Resetting	3-21
3.12	Setting up Auto Logging	3-22
3.13	Setting the Viewing Conditions	3-24

3.1 Mounting the Microphone

Before mounting the microphone, note the following precautions:

- When screwing in the microphone, input stage, protection grid and extension cables, **do it gently** to avoid damaging the threads
- Do not touch the diaphragm with any object — it is very delicate. Small amounts of dust on the diaphragm will not affect the microphone response.

Mounting the Microphone and Input Stage

1. Gently screw Microphone Type 4188 (supplied with the sound level meter) onto Input Stage ZC0025.
2. Insert the input stage into the input stage socket and secure by turning the threaded retaining ring (see Fig. 3.1).

Connecting the Microphone Extension Cable

1. Gently screw Microphone Type 4188 (supplied with the sound level meter) onto Input Stage ZC0025.
2. Insert the input stage into Microphone Extension Cable AO0408 (3m) or AO0409 (10m). Secure the connection by turning the threaded retaining ring.
3. Insert the other end of the microphone extension cable into the input stage socket and secure by turning the threaded retaining ring (see Fig. 3.2).

Note: Connecting a recommended microphone extension cable has no effect on the sound level meter's calibration. Therefore, you do not have to recalibrate after connecting one of the recommended microphone extension cables.

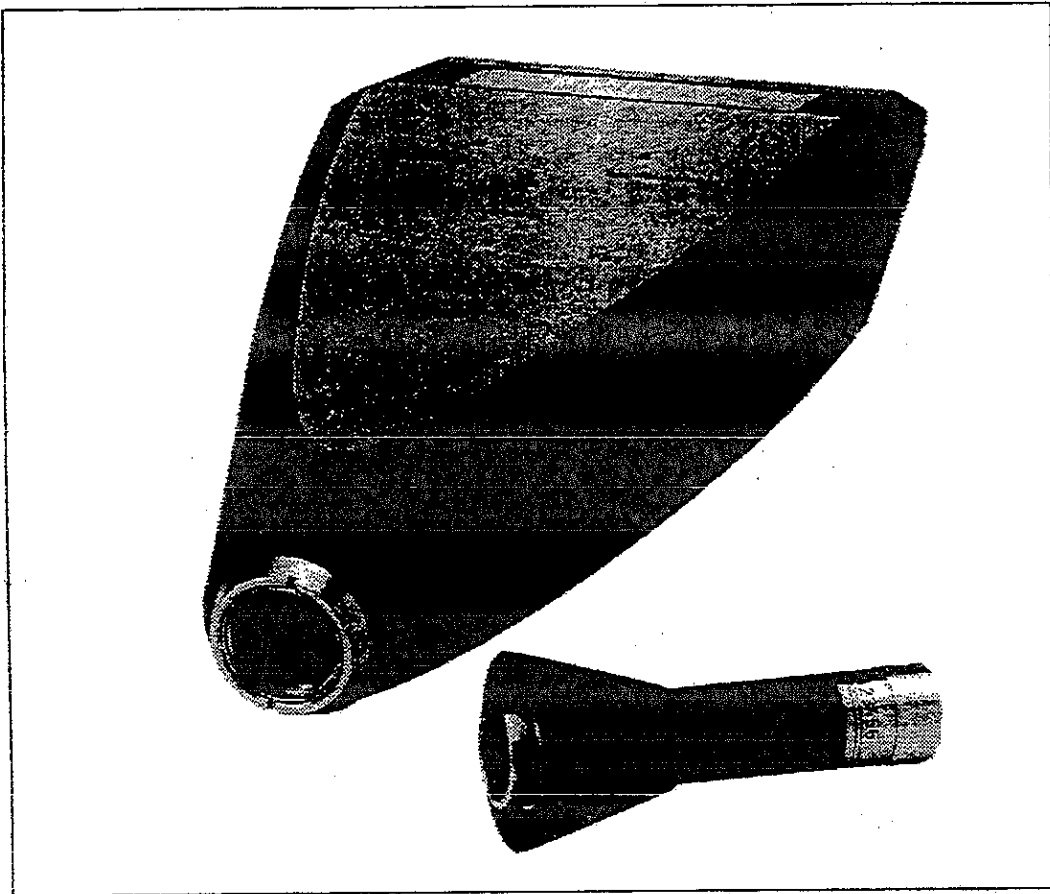

Fig. 3.1 Mounting the input stage and microphone onto the sound level meter

3.2 Fitting Batteries

3.2.1 Replacing Batteries

1. Press the two tabs on the upper edge of the battery compartment and remove the lid.
2. Replace the old batteries with new ones (four 1.5V LR6/AA size alkaline batteries) as shown in the battery compartment and press the compartment lid back into place.

Chapter 3 – Setting Up the SLM for Measurement Fitting Batteries

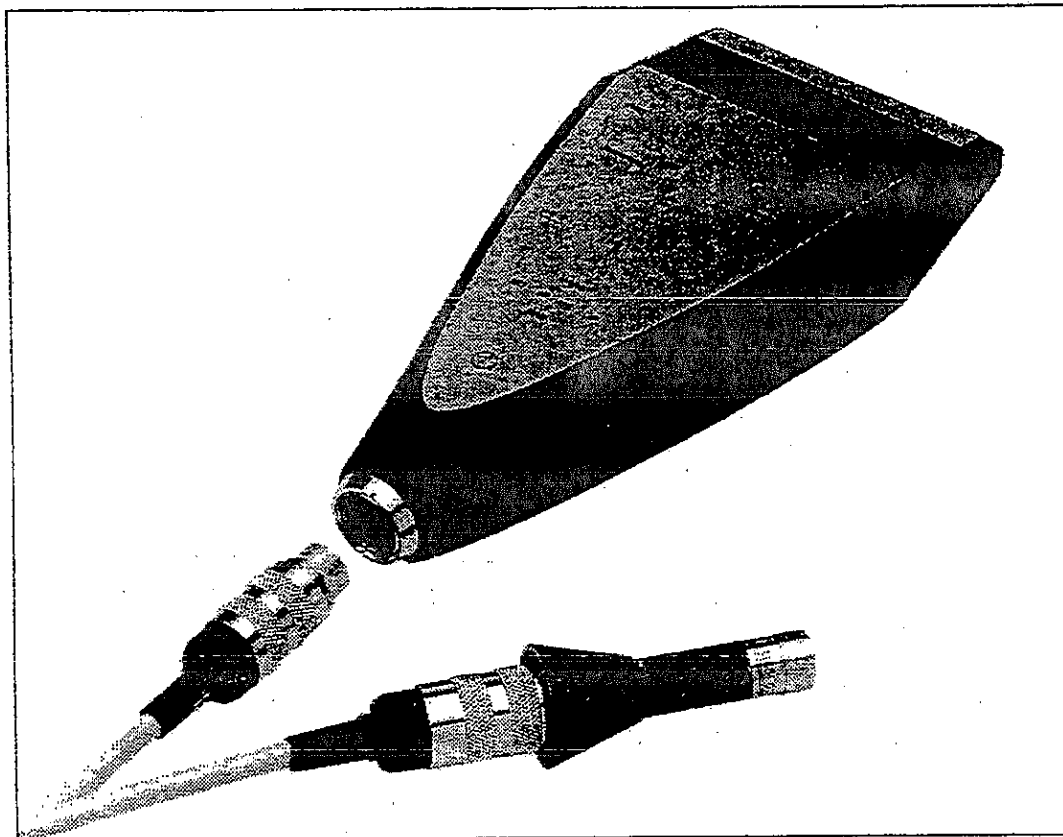

Fig. 3.2 Connecting a microphone extension cable to the sound level meter

Note: If you cannot switch on the sound level meter after replacing the batteries, check that they are correctly inserted. The sound level meter is designed so that it will not work if the batteries are wrongly inserted in the battery compartment.

Warnings!

It is possible for batteries to explode or leak if they are handled incorrectly, so:

- For long-term storage, remove the batteries and keep the sound level meter in a dry place.
- Never mix different makes or types of battery.
- Never mix charged and discharged batteries.

- Always label the outside of the battery compartment with the type of batteries contained.

3.2.2 Using an External Power Supply

The sound level meter can be powered from a regulated or smoothed 7–15V DC supply via the **External Power** socket on the base (e.g. from the mains supply via an adaptor).

You can connect the external power supply even when the batteries are installed. The sound level meter automatically selects the source with the highest supply voltage. The external power supply will not damage the batteries but neither will it recharge the batteries.

3.2.3 The Back-up Battery

The sound level meter has a back-up battery for running the clock and maintaining the memory, log and buffer, even when the sound level meter is switched off or the main batteries are removed.

The back-up battery is automatically recharged when there are batteries in the sound level meter. It is fully charged after about 10 hours. Fully charged, the back-up battery runs the clock and retains the results for about 6 months.

These times are typical for a sound level meter at room temperature.

If the back-up battery is flat, the date and time will be reset to a factory set date. If you find that the date and time are wrong, this is probably the reason.

3.3 Switching the SLM On and Off

Switching the Sound Level Meter On

Press ①.

The sound level meter tests its memory and then returns to Pause mode with the set-up it had when it was last switched off. While testing its memory, the display shows the version of the sound level meter (e.g. 2236 A-007).

The default set-up is:

Frequency weighting (RMS):	A
Frequency weighting (Peak):	C
Time weighting:	F
Displayed parameter:	SPL
Displayed range:	30 – 110dB
Output formats:	Overall Results Short Heading Logged Results Short Heading Printer Level Distribution Short Heading 5dB resolution Cumulative Distribution Short Heading 5dB resolution
L _{N1} :	L ₁₀
L _{N2} :	L ₅₀
L _{N3} :	L ₉₀
Auto logging:	Off
Exposure Time:	7:30 hours
Exchange Rate:	5dB
Reset at range change:	On
Auto start:	Off

Note: To switch the sound level meter on in the default set-up, press and hold ⊖ and then press ① for about 1 second. The sound level meter erases all results in the buffer and returns to the default set-up in Pause mode. Note that this

procedure will reset your calibration. You must therefore recalibrate your instrument as described in section 4.1 after resetting. We recommend that you do not reset the instrument in this way if you are using an accredited calibration. Baud rate and handshake are not effected.

Note: To erase all results in the log, memory and buffer, press \ominus and \langle Data \rangle .

Switching the Sound Level Meter Off

Press $\textcircled{1}$.

The sound level meter goes into Pause mode and switches off. No measurement data from the buffer, log and memory are lost.

3.4 Setting the Measurement Range

The measurement range is shown to the left and right of the quasi-analogue scale. Sound level meters without filter sets (Types 2236 A-007 and 2236 B-007) have 5 measurement ranges each with a dynamic range of 80 dB. Sound level meters with filter sets (Types 2236 C-007 and 2236 D-007) have an extra measurement range from 10 to 90 dB (you must have one of the octave filters activated to select this range):

- 10 – 90dB*
- 20 – 100dB
- 30 – 110dB
- 40 – 120dB
- 50 – 130dB
- 60 – 140dB

* Only available with sound level meters that include filter sets (Types 2236 C-007 and 2236 D-007) and when the filter is selected.

Chapter 3 – Setting Up the SLM for Measurement Setting the Measurement Range

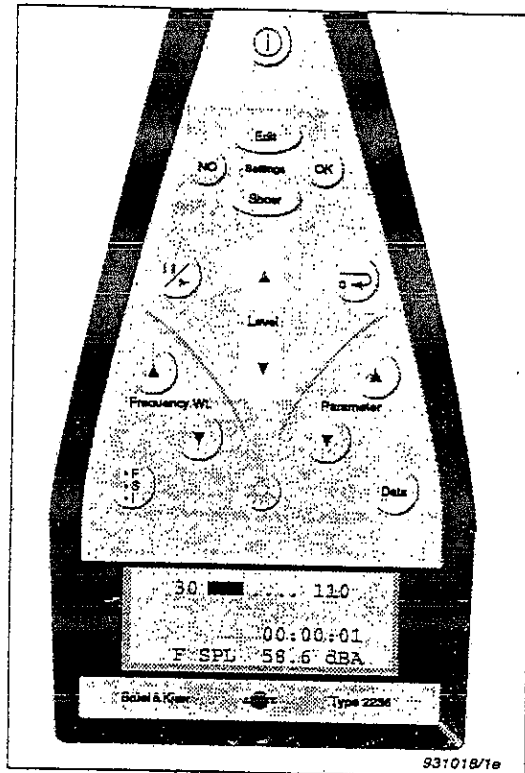

To move the measurement range by 10dB, press **Level** (▲) or (▼), respectively*

If you have selected a measurement range that is too low, the signal will cause an overload. If the sound level meter is currently overloaded, a + is shown to the right of the quasi-analogue scale. If the sound level meter has been overloaded during a measurement since the last reset, OVL is shown at the right-hand side of the screen, under the quasi-analogue scale.

* You can set the sound level meter to reset when changing the measurement range (see section 3.11). Then, if there are more than 1 minute of measurement results in the buffer (i.e. the elapsed time shown is greater than 1 minute), the screen tells you that changing the measurement range will erase all previous measurement results from the buffer. If you do not want to erase the measurement results, press (NO). The measurement range will not change. Press (OK) to change the range and erase the measurement results.

3.5 Setting the Time Weighting

The time weightings available are shown below:

- F: for normal measurements
- S: for checking average levels of fluctuating noise
- I: for measuring impulsive noise

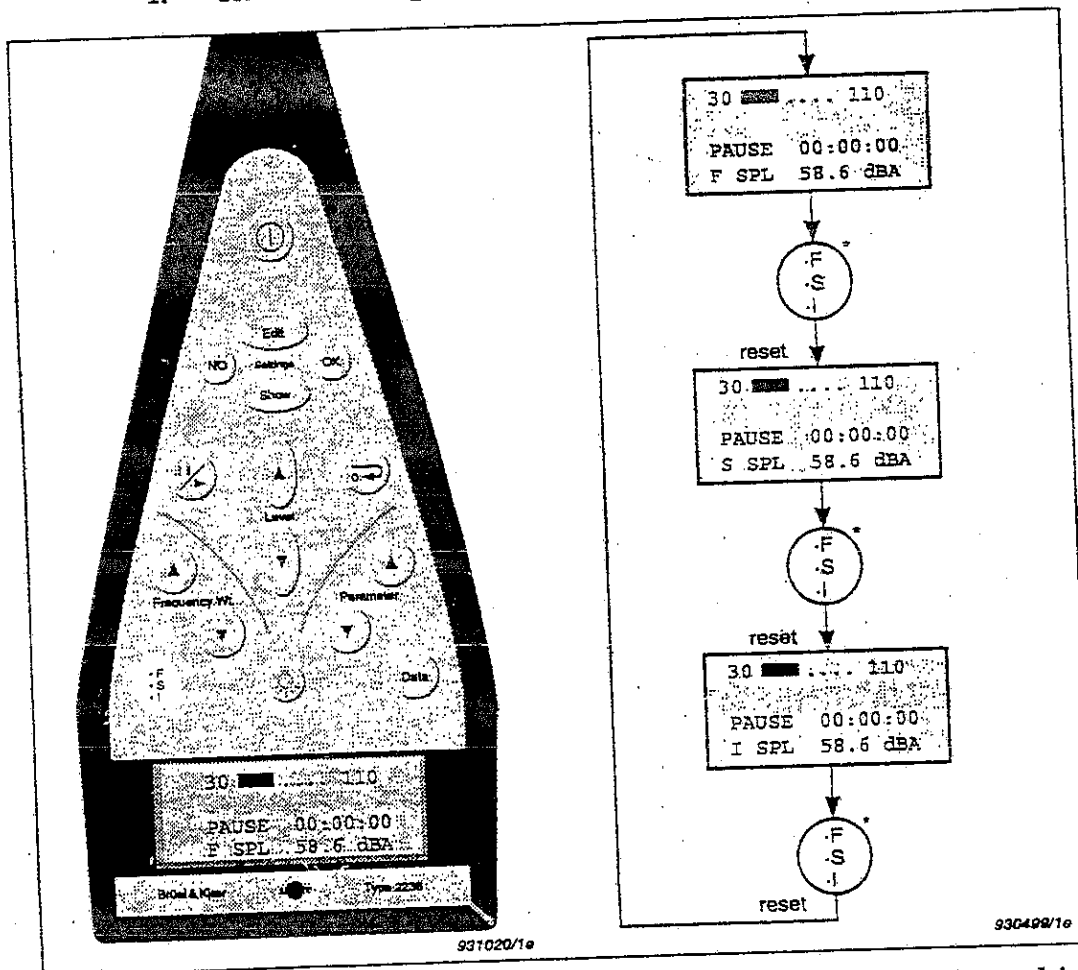

The display shows N.A. if you select a time weighting which is not available with the current displayed parameter or Exchange Rate.

* If there are more than 1 min of measurement results in the buffer (i.e. the elapsed time shown is greater than 1 min), the screen tells you that changing the time weighting will erase all previous measurement results from the buffer.
 If you do not want to erase the measurement results, press (NO).
 Press (OK) to change the time weighting and erase the measurement results.

Chapter 3 – Setting Up the SLM for Measurement Setting the Frequency Weighting

Note: If results are being logged every 0.1 s, the sound level meter sets the time weighting to 12 ms (shown on the display by σ). You cannot change the time weighting until you change the logging rate or set auto logging to off (see section 3.12).

3.6 Setting the Frequency Weighting

3.6.1 Introduction

If the selected parameter is Peak or MaxP, then the frequency weighting of the Peak signal is shown. Otherwise, the frequency weighting of the RMS signal is shown. Therefore, the frequency weighting shown always corresponds to the selected parameter.

3.6.2 Setting the RMS Frequency Weighting

The available frequency weightings of the RMS signal are shown below:

- A: for general sound level measurements
- C: for checking the low-frequency content of a noise (if the C-weighted level is much higher than the A-weighted level, then there is a large amount of low-frequency noise)
- L: for determining the “unweighted” SPL
- XHz: (with filters) for measuring the frequency content of a noise in order to choose, for example, the relevant hearing protection

* If there are more than 1 min of measurement results in the buffer (i.e. the elapsed time shown is greater than 1 min), the screen tells you that changing the frequency weighting will erase all previous measurement results from the buffer.

If you do not want to erase the measurement results, press $\langle \text{NO} \rangle$.

Press $\langle \text{OK} \rangle$ to change the frequency weighting and erase the measurement results.

† Press Frequency Wt. $\langle \blacktriangle \rangle$ to change the frequency weighting in the opposite direction to Frequency Wt. $\langle \blacktriangledown \rangle$.

Chapter 3 – Setting Up the SLM for Measurement

Setting the Frequency Weighting

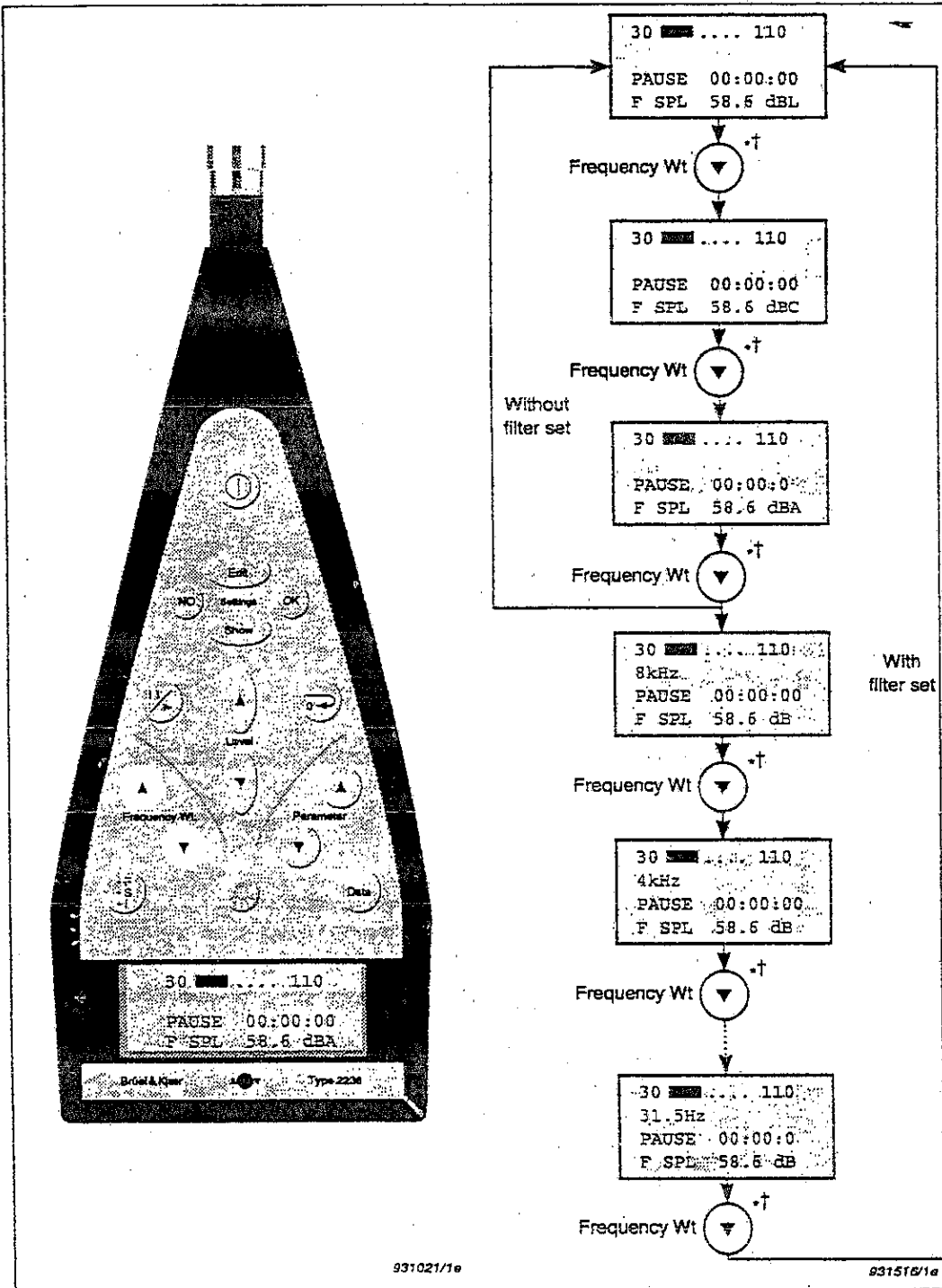

* See footnote on previous page.
 † See footnote on previous page.

3.6.3 Setting the Peak Frequency Weighting

The available frequency weightings of the Peak signal are shown below:

- C: for measuring the damaging effects of noise
- L: for special applications

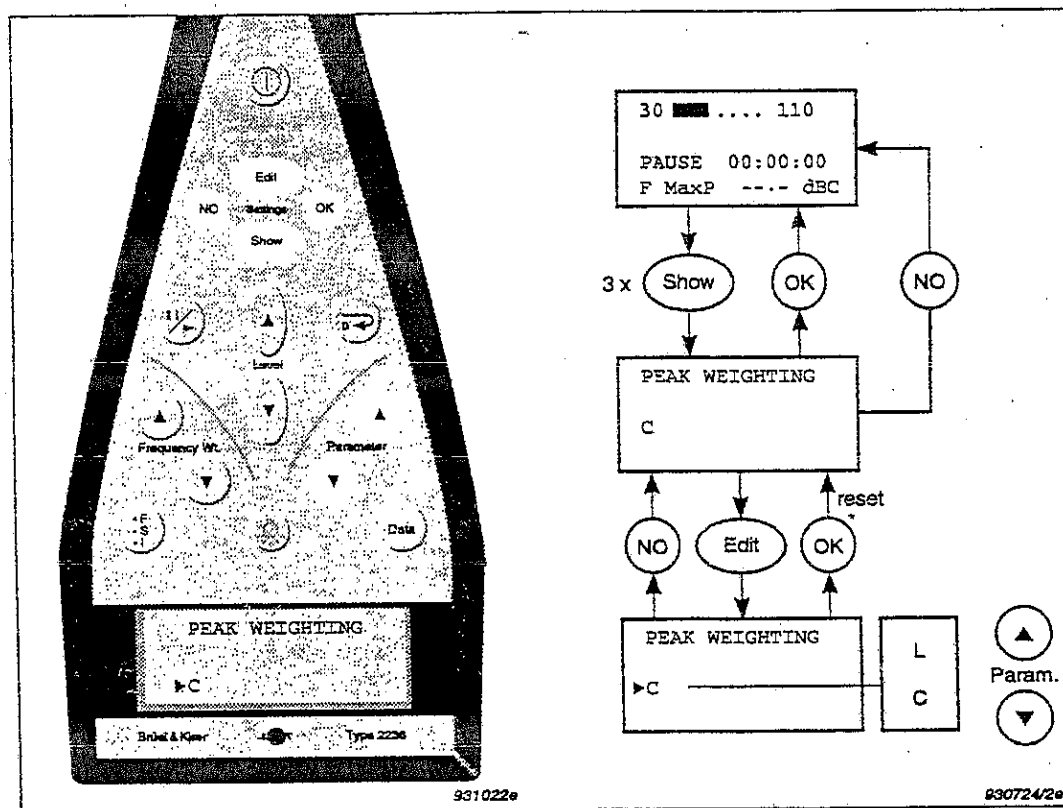

* If there are more than 1 min of measurement results in the buffer (i.e. the elapsed time shown is greater than 1 min), the screen tells you that changing the frequency weighting will erase all previous measurement results from the buffer.
 If you do not want to erase the measurement results, press **NO**.
 Press **OK** to change the frequency weighting and erase the measurement results.

3.7 Setting the Percentiles

Three L_N parameters (percentile levels) are transferred over the interface to a printer or computer (see sections 5.6 and 5.7) with Overall Results. You can choose three percentiles or use the default percentiles L_{10} , L_{50} and L_{90} . The selected percentiles can also be displayed one after another on the display (see section 4.8). N can have values of between 1 and 99 in integer (1) steps.

Note:

- Changing the percentiles does not reset the sound level meter. Therefore, you can view any percentile levels during or after a measurement.
- The sound level meter always logs L_{10} and L_{90} in Logged Results, regardless of the percentiles you have selected.

Chapter 3 – Setting Up the SLM for Measurement Setting the Percentiles

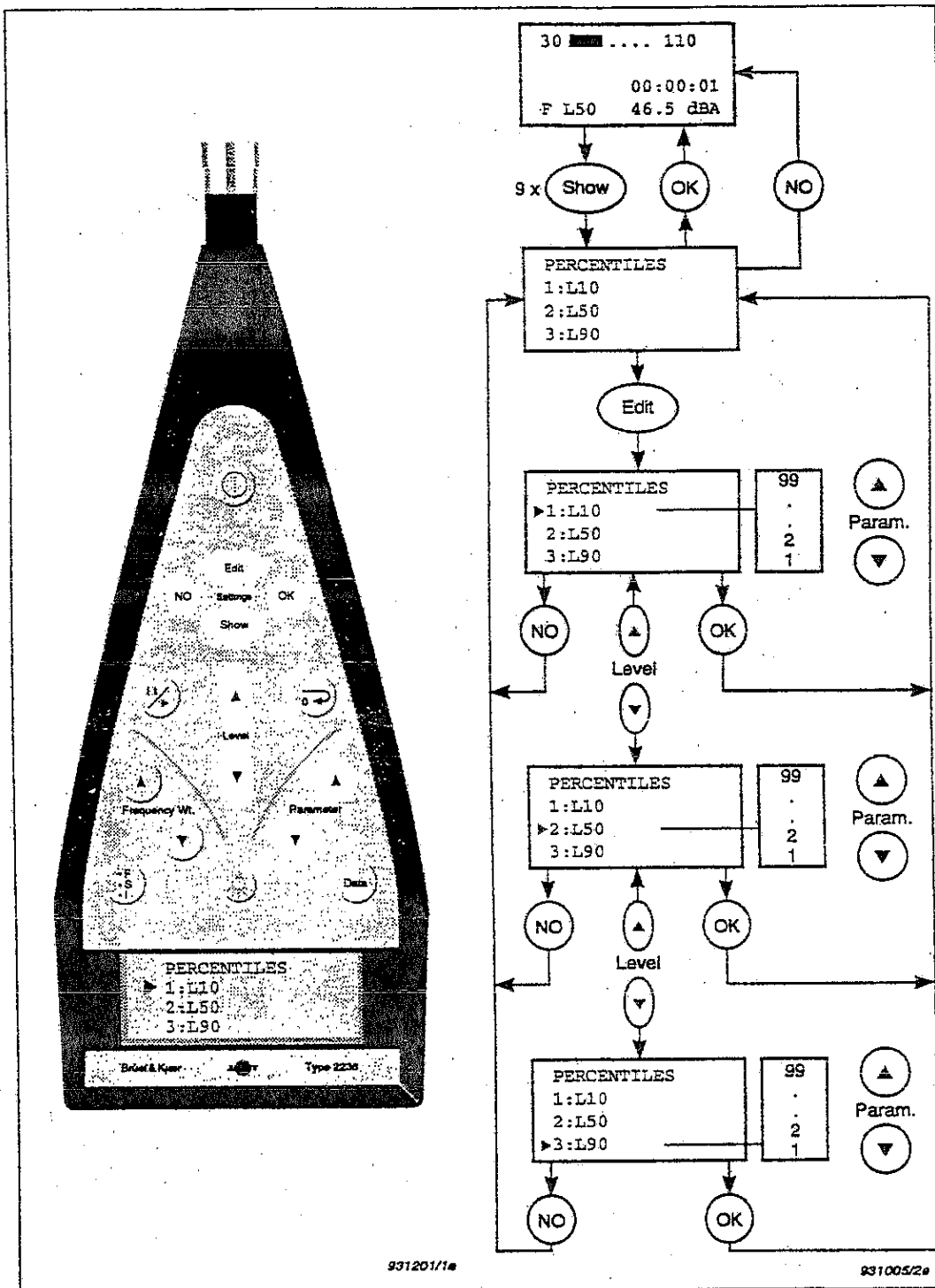

3.8 Setting the Exchange Rate

Exchange Rate is described in section 8.1.

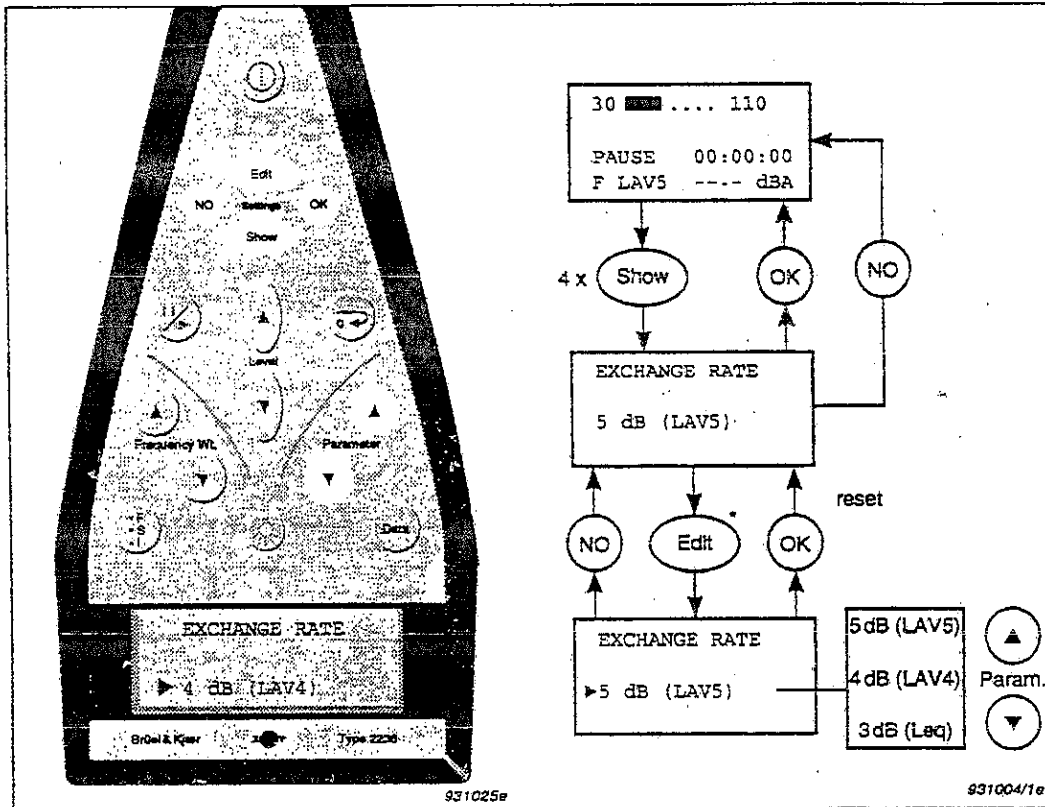

The display and logged values show N.A. if you select an Exchange Rate which is not available with the current time weighting.

- If there are more than 1 min of measurement results in the buffer (i.e. the elapsed time shown is greater than 1 min), the screen tells you that changing the Exchange Rate will erase all previous measurement results from the buffer. If you do not want to erase the measurement results, press **(NO)**. Press **(OK)** to change the Exchange Rate and erase the measurement results.

Chapter 3—Setting Up the SLM for Measurement Setting the Exposure Time

The current Exchange Rate line also indicates which L_{AV} parameter is currently selected (see Table 3.1). If the Exchange Rate is 3dB, $L_{EP,d}$ (see section 8.3) is also calculated by the sound level meter.

Exchange Rate (dB)	L_{AV} Parameter
3	L_{eq}
4	$L_{AV,4}$ (L _{DOD})
5	$L_{AV,5}$ (L _{OSHA})

Table 3.1 The L_{AV} parameter measured and displayed is dependent on the Exchange Rate

3.9 Setting the Exposure Time

Exposure Time is used in the calculation of $L_{EP,d}$ (see section 8.3). It can have values of between 1min and 24hours.

Note: Changing the Exposure Time does not reset the sound level meter. Therefore, you can investigate the effect of different Exposure Times on the $L_{EP,d}$ after a measurement.

Chapter 3 – Setting Up the SLM for Measurement

Setting the Exposure Time

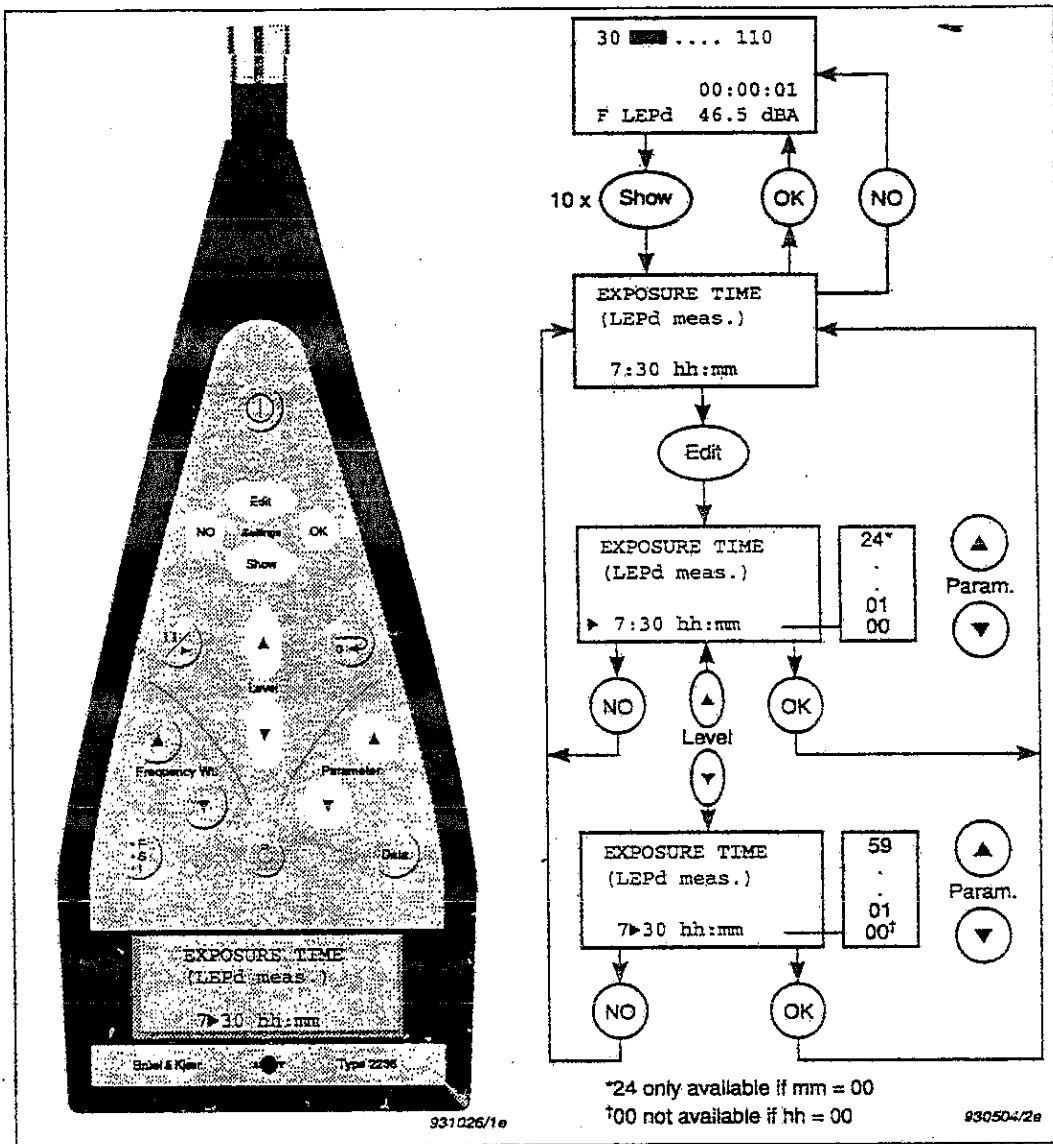

3.10 Setting the Date and Time

The sound level meter's clock operates, even when the sound level meter is switched off, if the internal back-up battery is charged up (see section 3.2.3). It is factory set to Central European Time.

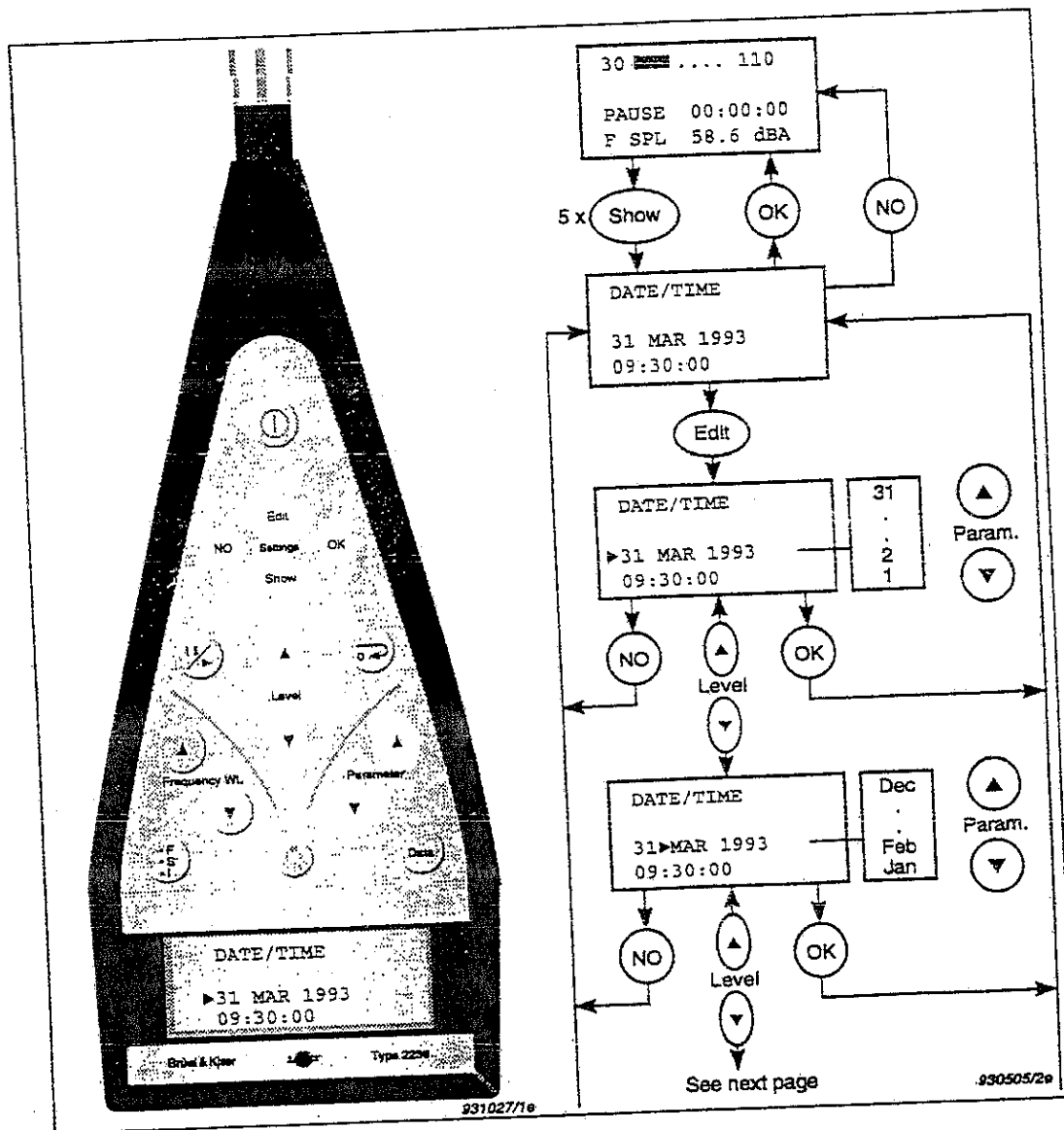

Chapter 3--Setting Up the SLM for Measurement

Setting the Date and Time

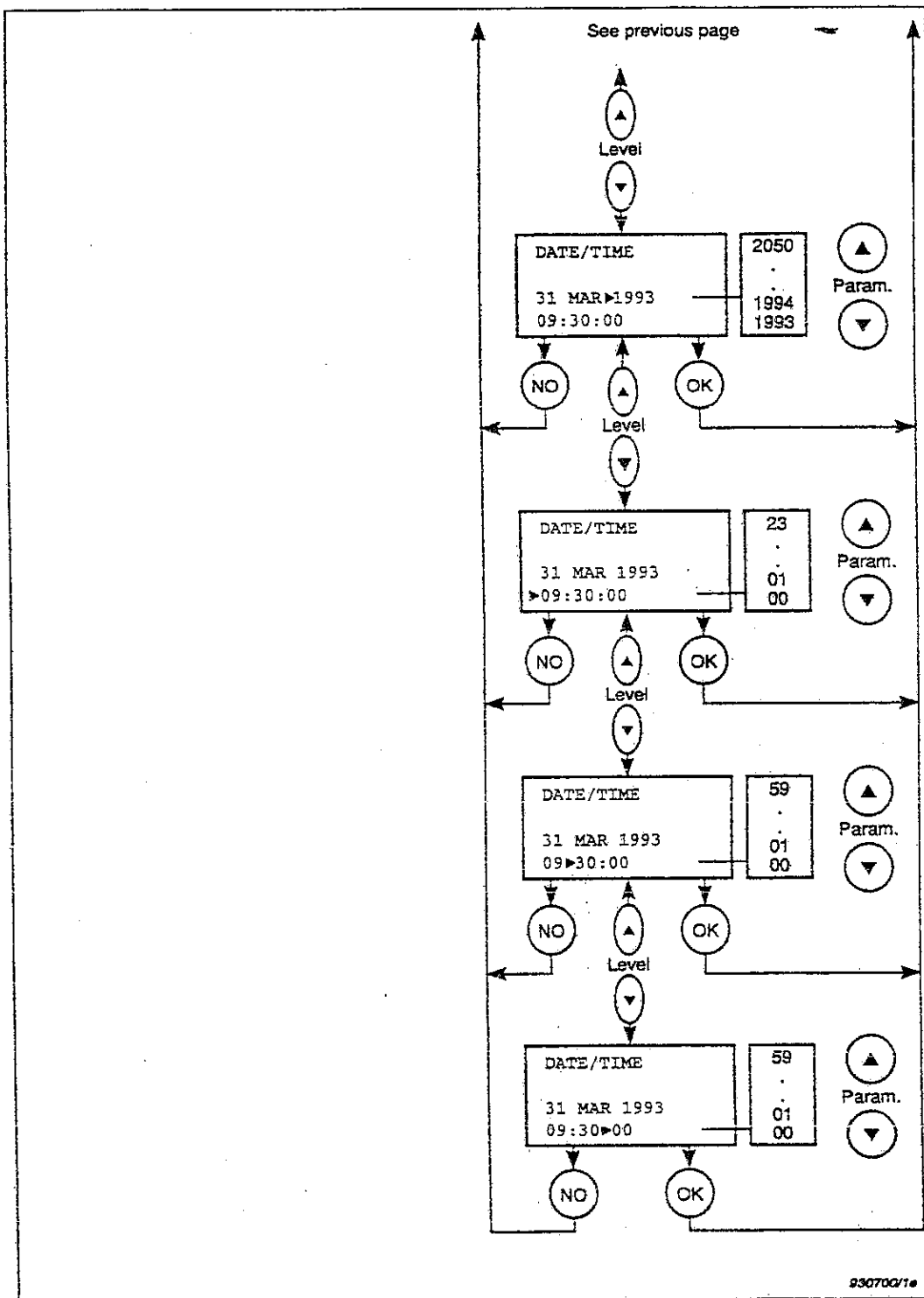

3.11 Setting the SLM to Change Range without Resetting

The sound level meter always resets when changing the frequency or time weighting, or Exchange Rate. The sound level meter also normally resets when changing the measurement range.

As an option, you can set the sound level meter to change measurement range without resetting. If you do this and change the range, the distributions and L_N parameters will not be available (N.A. will be shown on the display if an L_N is selected). If the sound level meter is logging when you do this, then all L_N values, including those already logged, will show N.A. To begin logging L_N values again, reset the sound level meter by Pressing \ominus

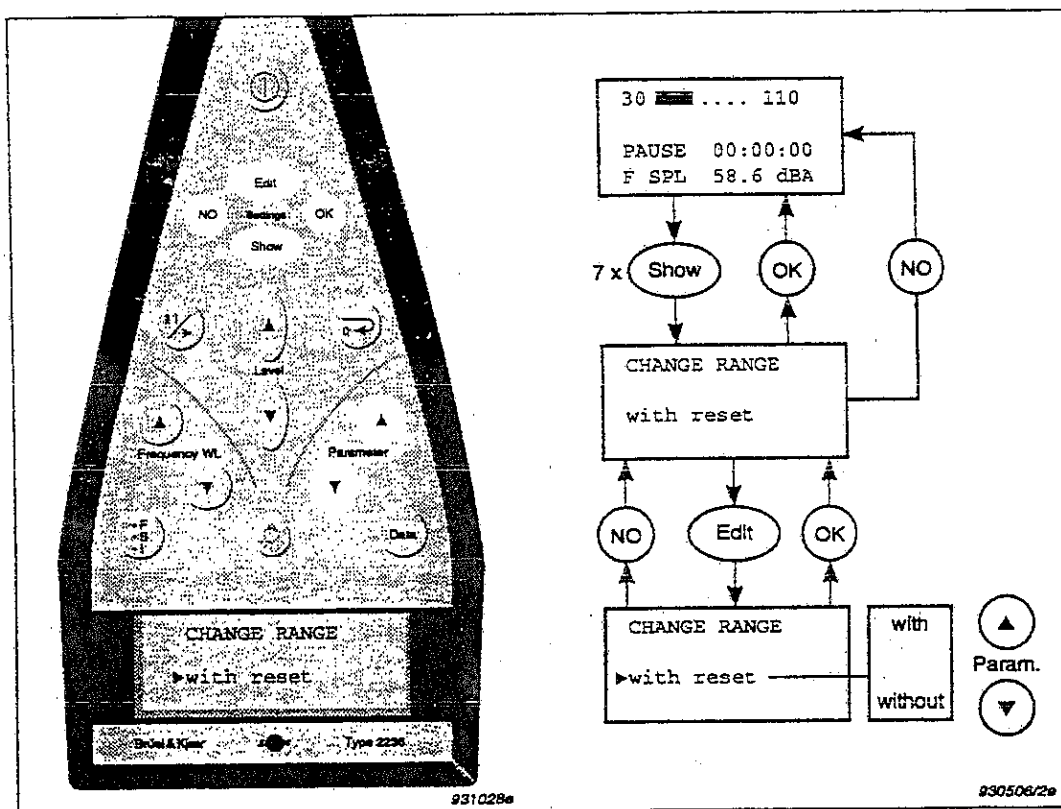

Note:

- If an overload has occurred, the results are not correct. You can, however, accept them (for example, if the overload was of relatively short duration). If the sound level meter is set to not reset when changing the measurement range, you will be unable to see from the Overall Results at which measurement range the overloads took place. You can, however, see when they took place in the Logged Results (see sections 5.6 and 5.7 for how to view them).
- The sound level meter takes 6 ms to change measurement range. If you change range when the sound pressure level is near its maximum and the sound level meter is set to not reset when changing the measurement range, you will reduce the accuracy of the measurement.

3.12 Setting up Auto Logging

You can set the sound level meter to automatically log:

- L_{eq} ($L_{AV,4}$ or $L_{AV,5}$ when the Exchange Rate is 4 or 5dB, respectively)
- L_{10}
- L_{90}
- measurement time of results

and store them at regular intervals in its log or send them via the **Serial Interface** to a PC. The logging time (i.e. the amount of time between each set of results) can be one of the following:

- | | |
|---------|---------|
| ● 0.1s* | ● 1min |
| ● 1s | ● 10min |
| ● 10s | ● 30min |
| | ● 1hour |

* Only L_{eq} is logged. The sound level meter sets the time weighting to 12ms (shown on the display by G). You cannot change the time weighting. When the logging time is subsequently reset to any other value, or auto logging is switched off, the time weighting is restored to its previous setting.

Chapter 3 – Setting Up the SLM for Measurement Setting up Auto Logging

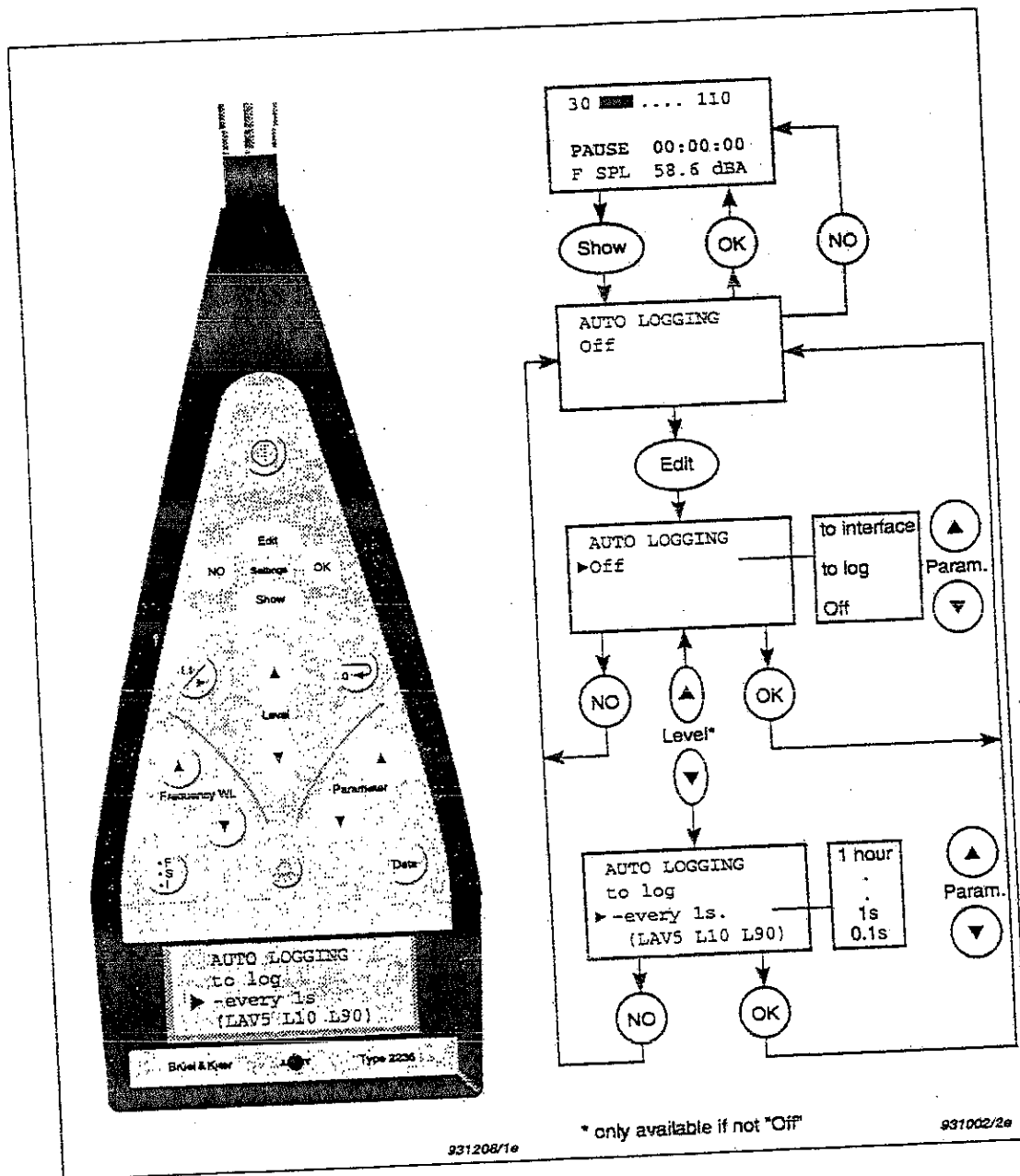

If you change the range, frequency weighting, time weighting or Exchange Rate while the sound level meter is set to log results in memory, the sound level meter stops logging and auto logging is set to Off. This is because the measurement set-up information in the log would no longer be relevant for further logged results.

Results are not logged while the sound level meter is in Pause mode. For more information about the way pauses will affect your log, see section 5.8.

Pressing Ⓢ does not erase the log. To erase the log, see section 5.3.

3.13 Setting the Viewing Conditions

The sound level meter's screen can be changed to cope with various lighting, temperatures, conditions and viewing angles. You can switch on a back-light and adjust the screen's contrast. The contrast adjustment may be especially useful in very high or very low temperature environments.

To switch the back-light on, press Ⓢ.

The back-light switches off automatically 30s after the last key press. To switch the back-light off before this, press Ⓢ.

To set the screen's contrast, follow the instructions below:

Chapter 3 -- Setting Up the SLM for Measurement Setting the Viewing Conditions

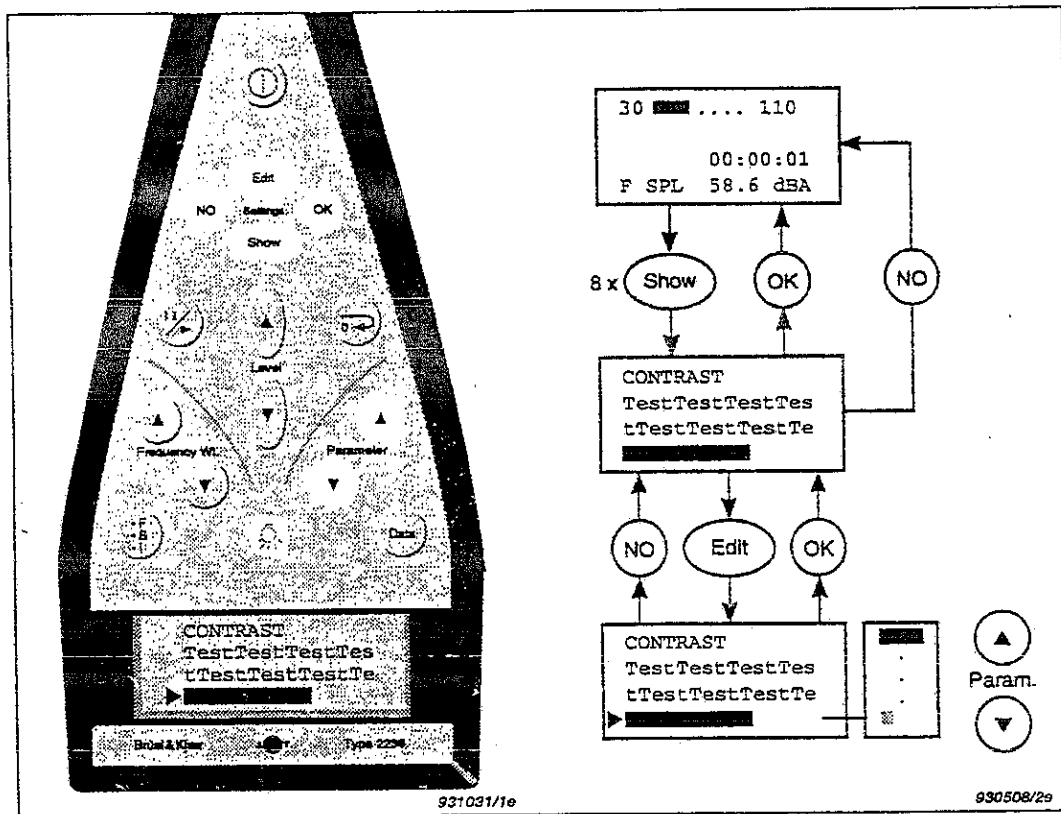

Chapter 3 – Setting Up the SLM for Measurement

Setting the Viewing Conditions

Chapter 4

Measuring

4.1	Calibrating.....	4-2
	Introduction	4-2
	Calibrating the Sound Level Meter.....	4-3
	Checking the Sound Level Meter's Calibration	4-5
4.2	Checking the Sound Level Meter.....	4-7
4.3	Starting a New Measurement	4-9
4.4	Pausing a Measurement	4-11
4.5	Continuing a Measurement	4-12
4.6	Starting a Frequency Analysis.....	4-13
4.7	Setting the SLM to Start Automatically	4-14
4.8	Changing the Displayed Parameter	4-16

4.1 Calibrating

4.1.1 Introduction

When to Calibrate

The standards recommend that you calibrate your sound level meter before each set of measurements (see section 4.1.2) and check the calibration after each set (see section 4.1.3).

Connecting a recommended microphone extension cable has no effect on the sound level meter's calibration. Therefore, you do not have to recalibrate after connecting one of the recommended microphone extension cables.

Principle of Calibration

The sound level meter uses a calibration factor to check for drift. This is shown on the Calibration screen. When calibrating, the sound level meter first checks the calibration signal against the calibration level you set. The sound level meter shows you the factor required for correct calibration and asks if you want to recalibrate. If you press **(OK)**, the sound level meter calibrates itself according to this new calibration level (i.e. it adjusts itself to the calibration level you entered).

During this procedure, the sound level meter is automatically set to use the reference measurement range and to show SPL on the display. The frequency and time weighting settings are not changed. Therefore, calibration at frequencies other than 1 kHz requires correction for the frequency weighting used (see Fig. 6.1).

Calibrating for Free Field or Diffuse Field Measurements

The sound level meter is calibrated in the same way for free field measurements (according to IEC) and diffuse field measurements (according to ANSI). However, the calibration levels for some calibrators may be different, depending on which measurements are to be made. See the calibrator's user manual for more details.

Always remove the Random Incidence Corrector DZ9566 (if fitted) from the microphone when calibrating or checking the calibration.

Which Calibrators Can I Use?

The sound level meter can be calibrated with Sound Level Calibrator Type 4231, Multifunction Acoustic Calibrator Type 4226 or a similar calibrator. All are referred to on the sound level meter's display as the calibrator.

Each calibrator is slightly different. The actual calibration level is not necessarily equal to the nominal calibration level. It is, therefore, important to set the calibration level to the one given on the calibration chart for the calibrator used.

4.1.2 Calibrating the Sound Level Meter

Sound Level Calibrator Type 4231 provides a nominal pressure field calibration signal of 94 or 114dB at 1kHz. The nominal diffuse field calibration signal is also 94 or 114dB but the nominal free field calibration signal is 93.8 or 113.8 dB.

Multifunction Acoustic Calibrator Type 4226 provides a nominal calibration signal of 94, 104 or 114dB at a range of frequencies.

For day to day calibration, you only need to calibrate at one level at one frequency. In order to comply with the standards, calibrate the sound level meter with a reference signal of 94dB at 1kHz*.

* Calibration at frequencies other than 1 kHz requires correction for the frequency weighting used (see Fig.6.1). The sound level meter can correct up to ± 0.5 dB from the nominal calibration level.

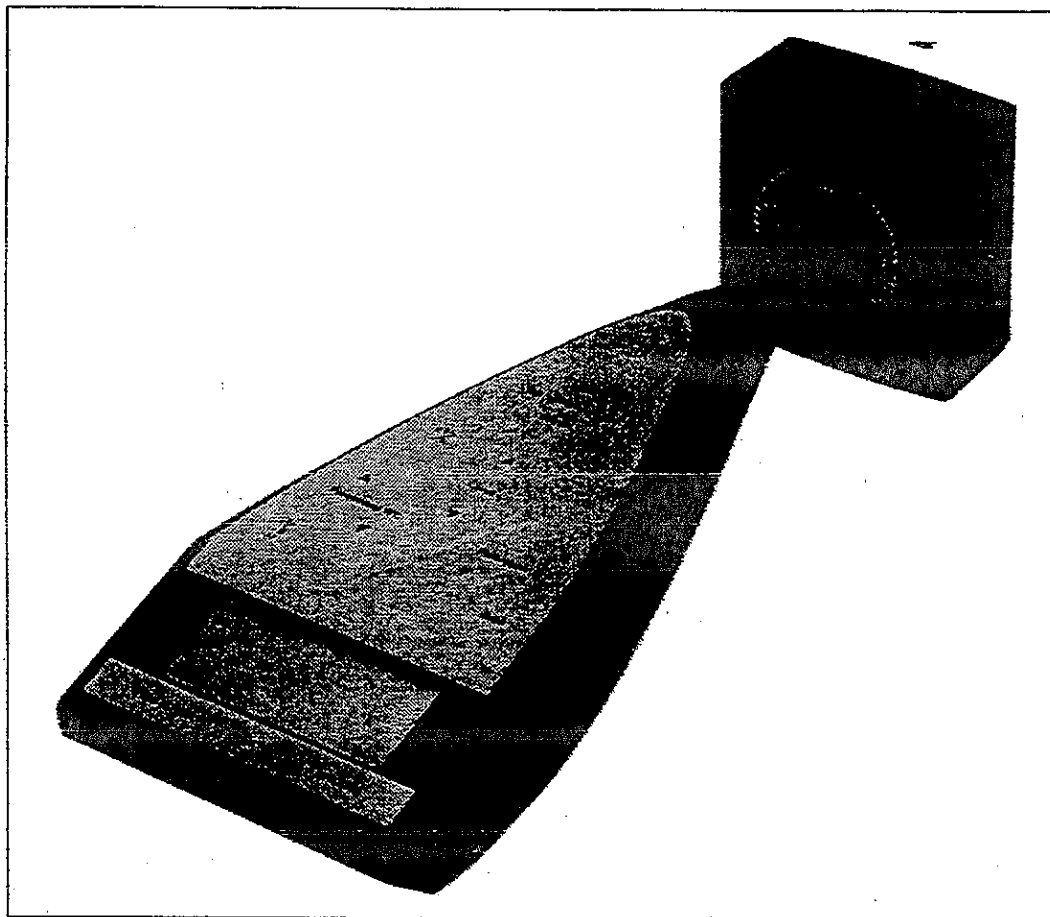

Fig. 4.1 Fitting Sound Level Calibrator Type 4231 onto the sound level meter. Multifunction Acoustic Calibrator Type 4226 is fitted in a similar way (see its manual)

To calibrate:

1. Fit the calibrator carefully onto the sound level meter and rest the sound level meter on a table or other flat surface. Ensure that the calibrator fits snugly on the microphone (see Fig. 4.1)
2. For the multifunction acoustic calibrator, set it up to calibrate at 94dB and 1kHz (see the calibrator's instruction manual).
3. Switch on the calibrator.
The calibrator emits a 1kHz calibration signal.
4. Follow the instructions given in the figure below to calibrate to the relevant level for the type of measurements to be made*:

4.1.3 Checking the Sound Level Meter's Calibration

Follow the instructions given in section 4.1.2 until the sound level meter asks whether you want to recalibrate or not. Press **(NO)** twice to return to the main screen.

* For Sound Level Calibrator Type 4231, choose a calibration level of 94dB for diffuse field or 93.8dB for free field. For Multifunction Acoustic Calibrator Type 4226, choose a calibration level of 94dB for both diffuse and free field.

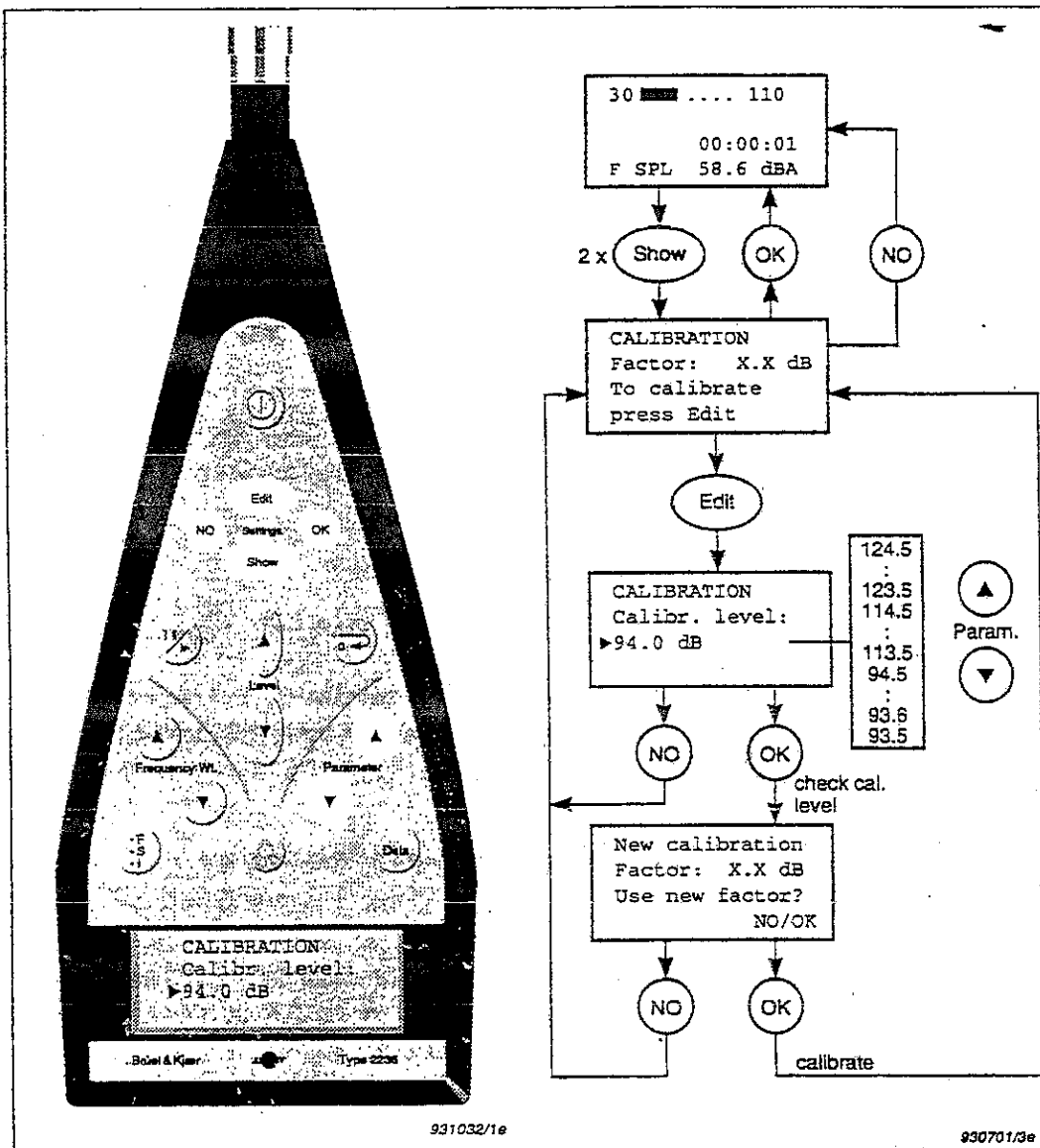

4.2 Checking the Sound Level Meter

Before you start a longer series of measurements, it is good practice to check the status of the sound level meter's battery, log and memory. To do this, press **<Edit>** and **<OK>**. The sound level meter shows the status screen. Press **<OK>** to return to the sound level meter's main screen.

```
STATUS
Battery   : 3.9 V
Free log  : 123h12
Free Records: 36
930988/1e
```

Fig. 4.2 The sound level meter's status screen

Battery:

With fresh batteries, the status screen will show approximately 6V. When there is about half an hour's operation left (when there is approximately 4V), the battery voltage level flashes ("3.9V" will flash in the example shown in Fig. 4.2)*; in very cold weather, much less than half an hour is left. The length of time fresh batteries last depends on the conditions of use (temperature, use of the back-light, etc.). Fresh alkaline batteries in a sound level meter without a filter set (Type 2236 A-007 or 2236 B-007) will take over 12 hours to wear out. Those in a sound level meter with a filter set (Type 2236 C-007 or 2236 D-007) will take over 10 hours to wear out.

Note: The battery voltage will normally be higher just after the sound level meter is switched on. Therefore, always wait a minute or so before checking the battery status.

* The main screen also shows a battery low warning (see Fold Out).

Chapter 4—Measuring Checking the Sound Level Meter

Free log:

The hours and minutes left in the log at the current rate of logging are shown.*

Free Records:

The number of empty Records left in the memory is also shown.

* Up to a maximum of 255h59.

4.3 Starting a New Measurement *

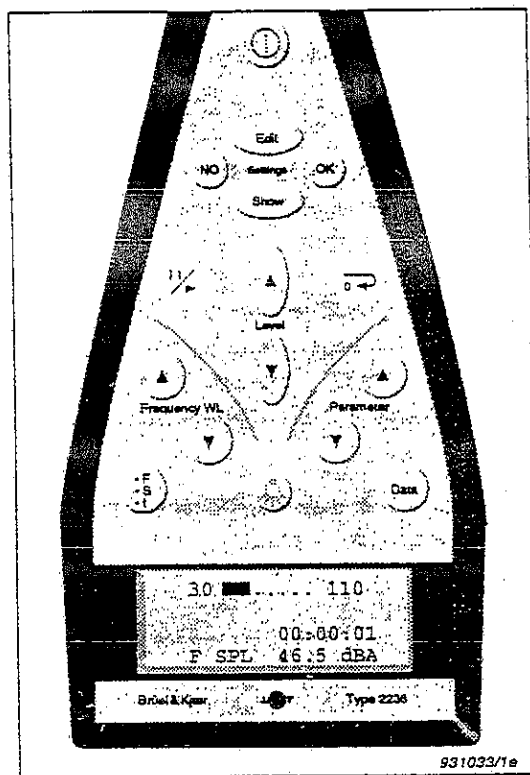

1. Calibrate the sound level meter as described in section 4.1.

2. Select a suitable measurement range.

This reduces the risk of you having to change the range during a measurement in order to avoid Overloads. Overloads reduce the validity of your results and changing the measurement range may cause a reset.

3. Press \odot .

If there are more than 1min of measurement results in the sound level meter's buffer (i.e. the elapsed time shown on the screen is greater than 1min), the screen tells you that resetting will erase all previous measurement results from the buffer. If this occurs, press \langle OK \rangle to confirm that you want to reset the sound level meter.

The results in the sound level meter's display buffer are erased and the elapsed time is set to zero. The overload hold is reset so that the sound level meter indicates that there have not been any overloads since the last reset.

Note: To erase all results in the Log, Memory and display buffer, press \odot and \langle Data \rangle .

* If you are only interested in instantaneous parameters (i.e. Peak or SPL), you can miss out steps 3 and 5

4. If you want to measure according to IEC standards (i.e. free field), simply point the sound level meter towards the sound source.

If you want to measure according to ANSI standards (i.e. diffuse field), fit the supplied Random Incidence Corrector DZ9566 on the microphone. The direction of the sound level meter is unimportant. If, however, the sound field is free, measure with the sound level meter at an angle of between 70 and 80° to the sound source.

5. Press Ⓜ .

The sound level meter starts measuring with the selected set-up.

Note:

- When mounting the sound level meter on a tripod, position the tripod so that one of its legs points in the same direction as the sound level meter. This will reduce the risk of damaging the microphone if the tripod is accidentally knocked over.
- See section 1.3 for practical hints and information about measuring according to standards.

4.6 Starting a Frequency Analysis*

A frequency analysis is a series of measurements in various frequency bands. Each measurement is made as for a normal broad-band measurement (see section 4.3).

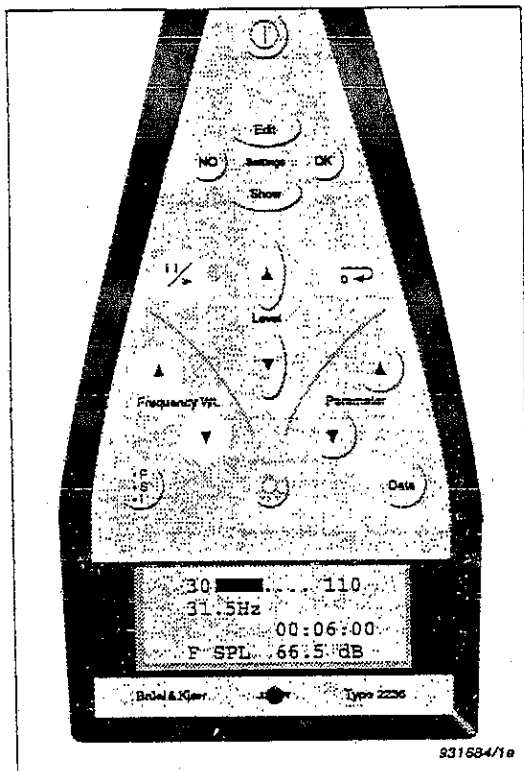

1. Using **Frequency Wt.** (\blacktriangle) or (\blacktriangledown), change the frequency weighting to the centre frequency of the band in which you want to start the analysis (see section 3.6.2).
2. Press ⊖ .
3. Press ⊗ .
4. After you have completed the measurement in that frequency band, press ⊗ .
5. Store the Overall Results in the Memory (see section 5.1).

6. Using **Frequency Wt.** (\blacktriangle) or (\blacktriangledown), change the frequency weighting to the centre frequency of the band in which you want to continue the analysis.

The sound level meter resets. You are now ready to measure in the next frequency band.

7. Repeat steps 3 to 6 for the other bands in which you want to analyse.

* Only available with sound level meters with filter sets (Types 2236 C-007 and 2236 D-007)

4.7 Setting the SLM to Start Automatically

The sound level meter can be set to automatically start at any time and date within the next month (e.g. from 19th May to 18th June).

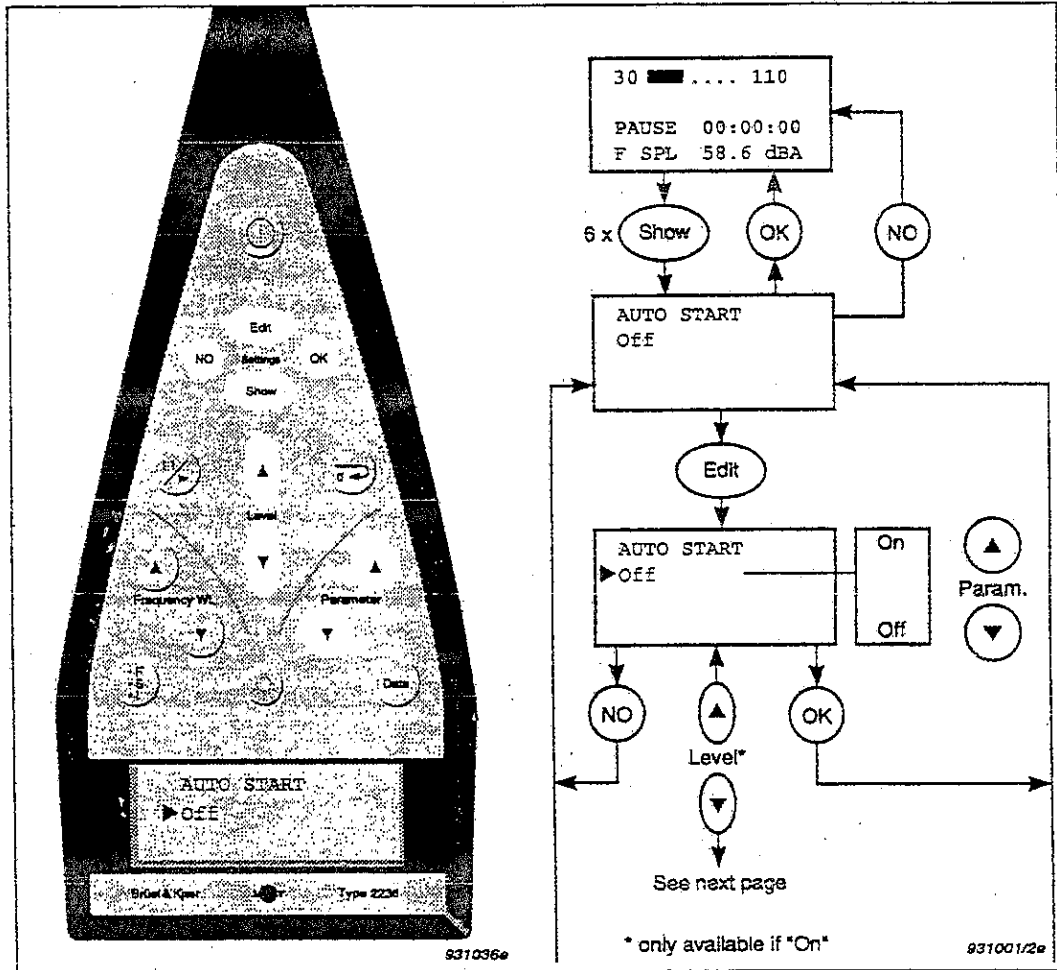

Chapter 4 – Measuring Setting the SLM to Start Automatically

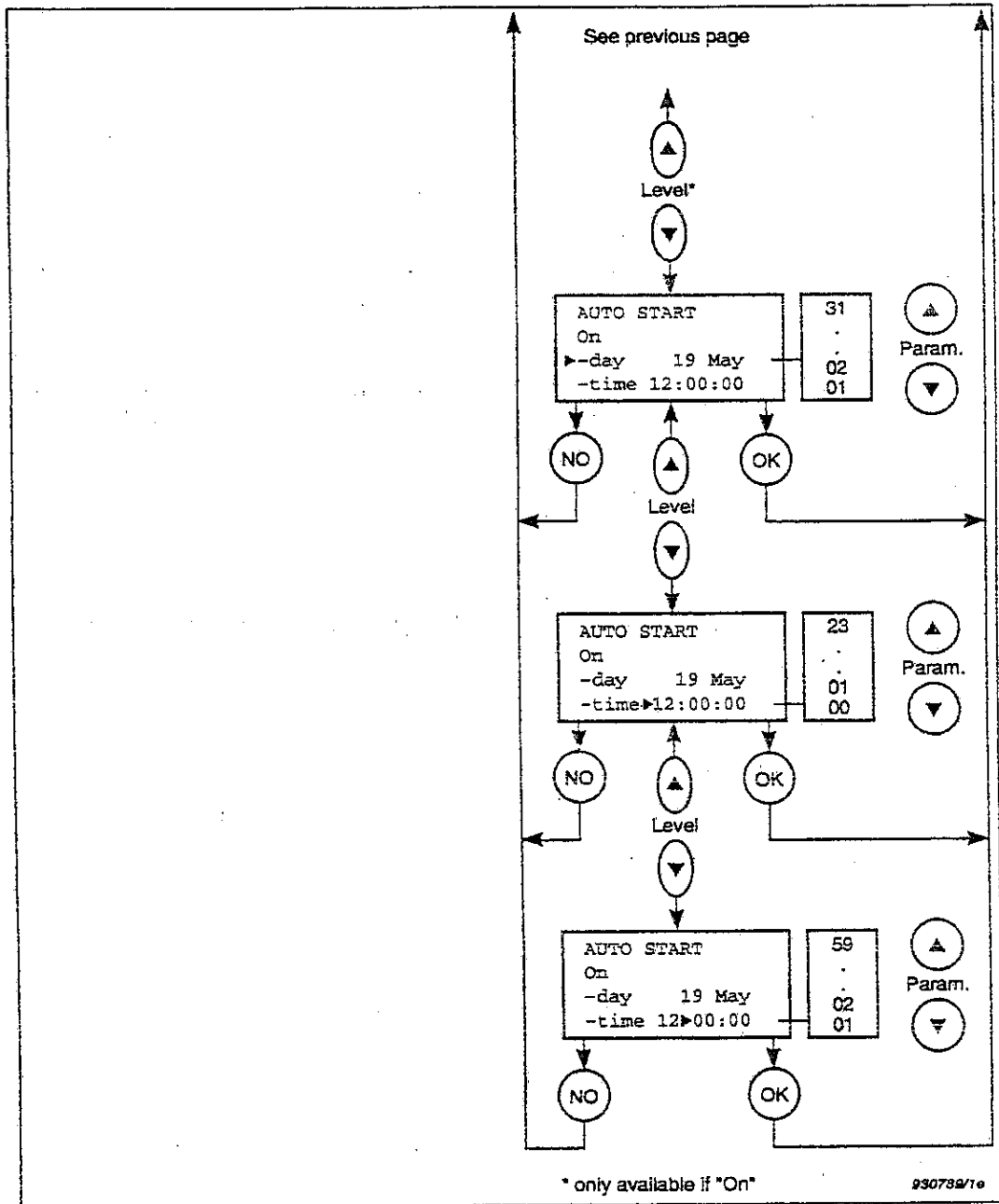

Auto Start only works if the sound level meter is switched off at the set time. Then, at this time, the sound level meter will switch on, reset and, after a pause of 5 seconds, start measuring with the set-up it had when it was switched off.

Once the sound level meter has started measuring with Auto Start, you can control it in the normal way. Measurement will continue until it is switched off manually or the batteries run out. Logging will continue until the memory is full or the batteries run out.

If the sound level meter is already switched on at the time it has been set to automatically start measuring, Auto Start is cancelled and has no effect.

When the set Auto Start time has passed, Auto Start will be switched off when you switch off the sound level meter (until then, it will appear as though it is set in the Auto Start screen). This prevents the sound level meter from repeating an automatic measurement every month.

Auto Start does not affect your use of the sound level meter while the sound level meter is switched on. Therefore, you can set the sound level meter to start measuring at a particular time and date while measuring without affecting your current measurement results.

4.8 Changing the Displayed Parameter

The parameters available are listed in section 1.2.1. The selected parameter and its level are shown at the bottom of the screen. After a reset, “—.” is shown for the level until after the first second after a Pause. This is because the level is not yet available. The quasi-analogue scale always shows the current RMS input signal level, regardless of the selected parameter.

Chapter 4 – Measuring Changing the Displayed Parameter

A DC level corresponding to the instantaneous RMS level is emitted from the **DC Output** socket at the base of the sound level meter for recording on a plotter. The signal emitted from the **AC Output** socket is unaffected by which parameter or frequency weighting is selected. It is always the L-weighted output from the preamplifier and is for recording noise signals on tape, transferring signals to an analyser or listening to the input on headphones.

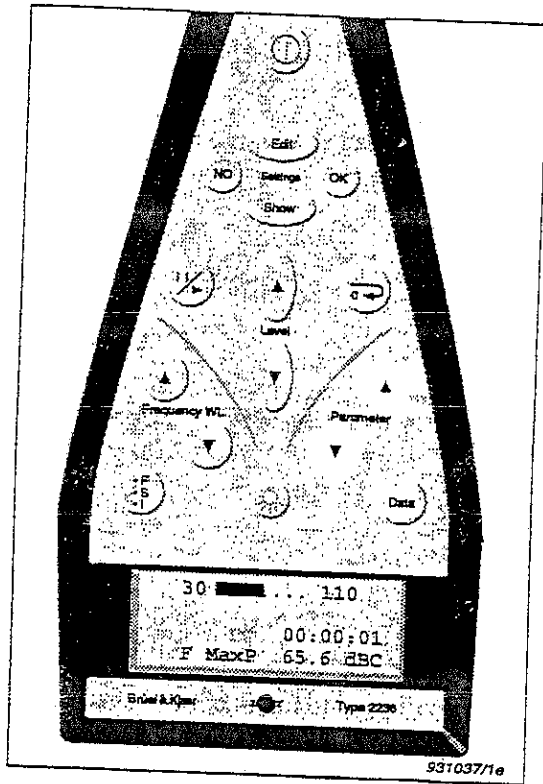

To step forwards and backwards through the available parameters, press **Parameter** (\blacktriangle) or (\blacktriangledown), respectively.

When a **Peak** parameter is shown, the frequency weighting shows the current weighting of the **Peak** signal. When an **RMS** parameter is shown, the frequency weighting shows the current weighting of the **RMS** signal.

The display shows **N.A.** if you select a displayed parameter which is not available with the current time weighting or after changing the measurement range without resetting.

Chapter 4—Measuring
Changing the Displayed Parameter

Chapter 5

Storing and Transferring Results

5.1	Storing Results in a Record	5-3
5.2	Recalling Results from a Record	5-4
5.3	Erasing Results	5-5
5.4	Setting up the Interface	5-6
5.5	Setting up the Output Formats	5-8
	Introduction	5-8
	Output Formats	5-10
	Level Distribution	5-14
	Cumulative Distribution	5-15
	Checking and Changing the Output Formats	5-16
5.6	Printing	5-17
5.7	Transferring Results to a Computer	5-20
5.8	Interpreting the Log Times	5-23

5.9 Recording on a DAT-recorder 5-24

5.1 Storing Results in a Record

Results in the buffer can be stored as one of 40 records in the sound level meter's memory. The results are stored in the first available record (that is, the first set of results in record 1, the next set in record 2, etc.).

Example: If you have stored 4 records and then erased record 2, the sound level meter will store the next set of results in record 2. The next set of results will then be stored in the first available record (that is, record 5).

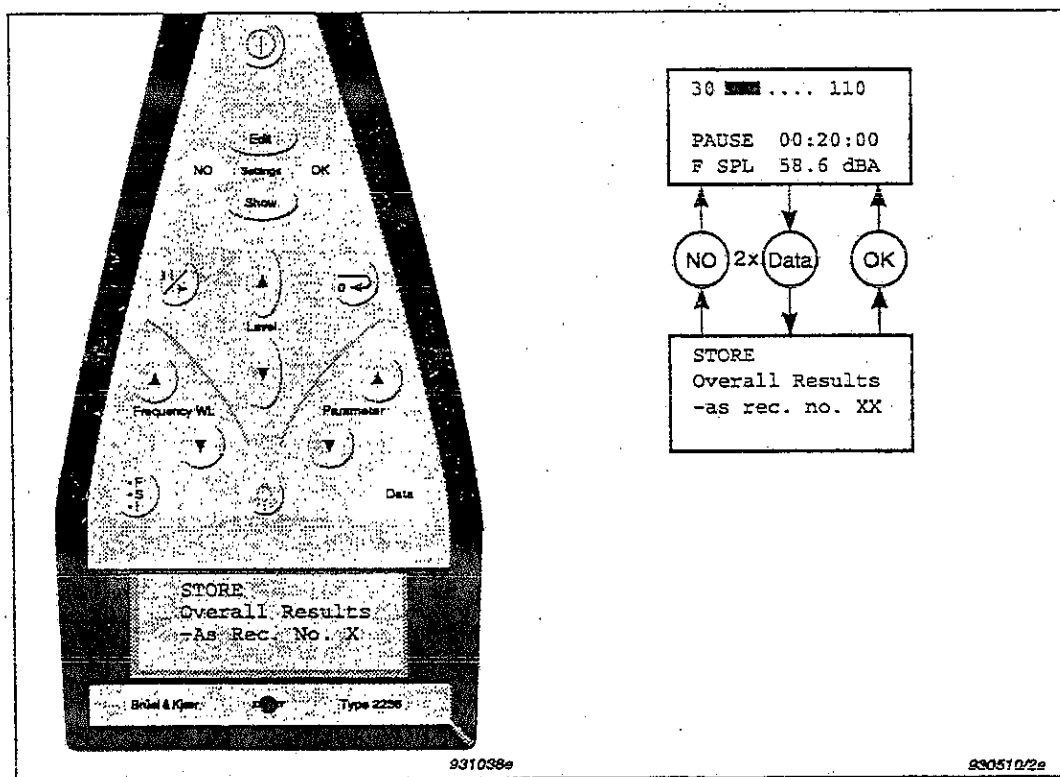

5.2 Recalling Results from a Record

Results in a record in the memory can be recalled to the sound level meter's buffer. You can then look at that record's Overall Results.

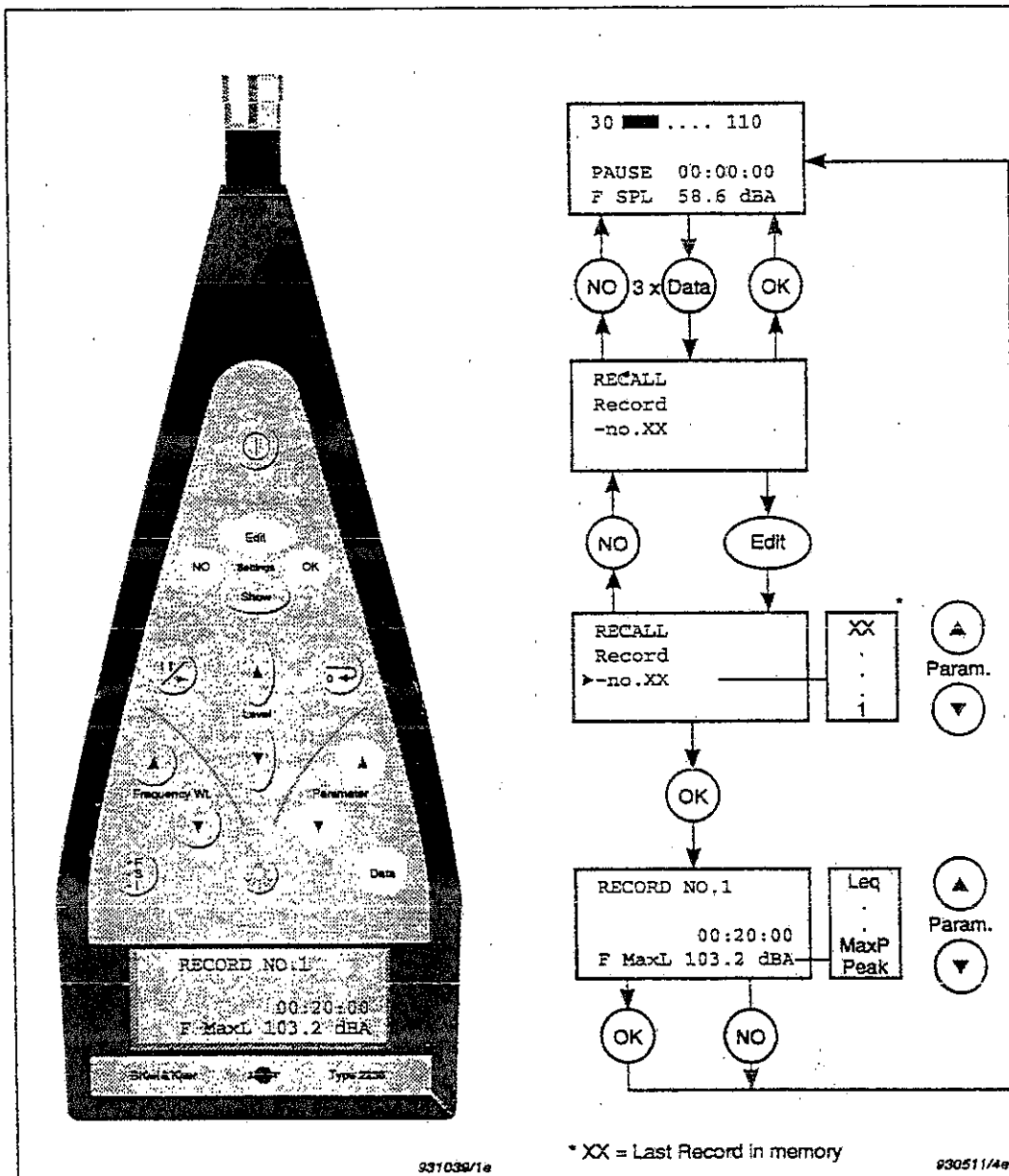

5.3 Erasing Results

You can erase results from a single record, all records (i.e. the entire memory) or the log.

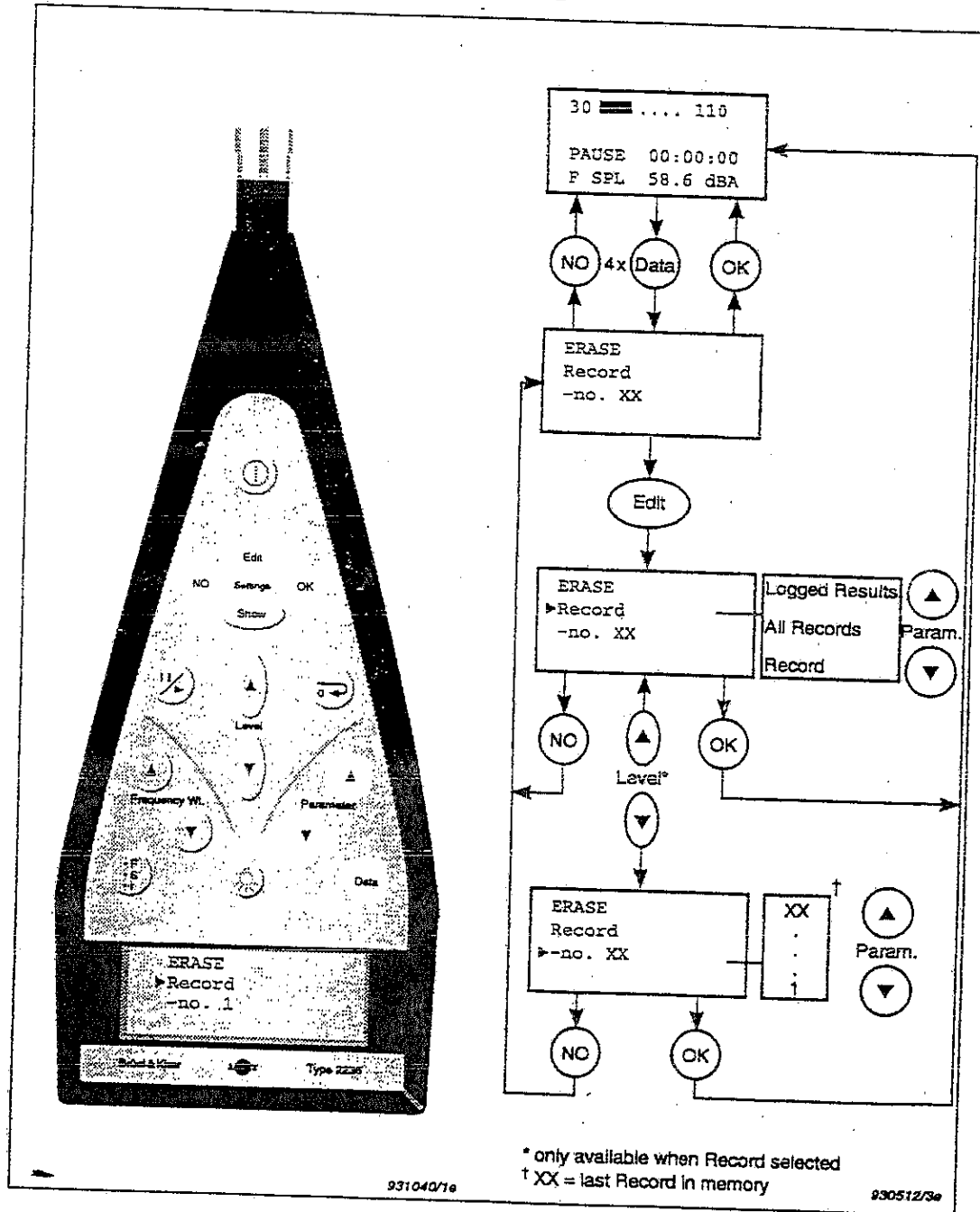

5.4 Setting up the Interface

The interfaces of the sound level meter and the instrument (e.g. printer or computer) it is connected to via the **Serial Interface** socket must have the same set-up to enable them to communicate without losing or corrupting data.

Both the handshake and baud rate of the sound level meter's interface can be set.

The following types of handshake are available:

- hardwire
- XON/XOFF
- none

The following baud rates are available:

- 1200
- 2400
- 4800
- 9600
- 19200

Chapter 5 – Storing and Transferring Results Setting up the Interface

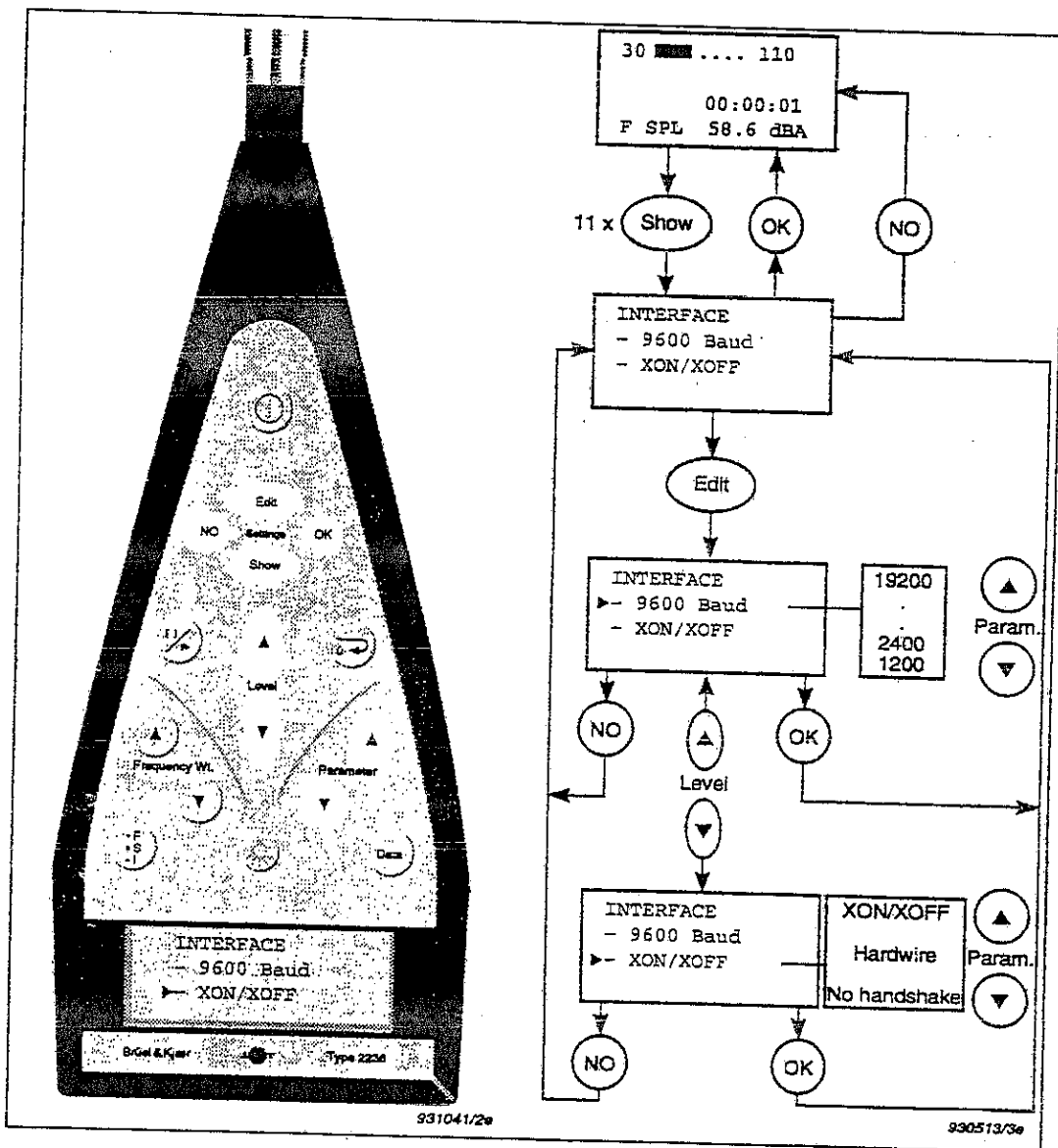

5.5 Setting up the Output Formats

5.5.1 Introduction

The output formats determine how the results are transferred to a printer or computer. Each type of result has its own independent output format.

Results

The following results are available with short headings:

- Overall Results (see section 1.2.4)
- Logged Results (see section 1.2.4)
- Level Distribution
- Cumulative Distribution

Short Heading

Bruel & Kjaer SLM Type 2236	
SETTINGS:	

F	50-130 dB
RMS:	Peak:C
OVERALL RESULTS:	

12 Apr 1993	08:35:50
Elapsed Time	00:15:00
Pauses	0
Overload	0.0 %
MaxP	105.9 dB
MaxL	95.3 dB
MinL	52.9 dB
LAV5	84.4 dB
SEL	113.9 dB
LEPd (Te=5h30)	N.A.
L10	94.0 dB
L50	76.3 dB
L90	55.0 dB
931163/2c	

The set-up of the sound level meter in a short format together with the date and time of the start of the measurement (Overall Results or distributions), or of the first logging (Logged Results). See Fig. 5.1 for an example of the Overall Results output format with a short heading.

Fig. 5.1 Overall Results output format with a short heading

5.5.2 Output Formats

You can print your logged results in any of the three formats described in this section. The format you choose will depend on the type of printer you are using.

Printer

For use with an IBM® Proprinter or compatible serial printer. The format is shown in Figs 5.2 and 5.3.

```

-----
    Bruel & Kjaer
    SLM Type 2236

SETTINGS:
-----
F           40-120 dB
RMS: A     Peak:C

LOGGED RESULTS:
-----
12 Apr 1993    15:11:19

hh:mm:ss    Lav5    L10    L90
            [dB]    [dB]    [dB]
15:11:19    73.8    92.0    65.7
15:11:20    78.6    99.1    69.0 P
15:11:24    76.1    96.8    66.5
15:11:25    78.4    92.3    70.6
15:11:26    75.1    101.2   73.7 P O
15:11:28    78.1    93.5    73.9
15:11:29    72.8    88.9    58.8
15:11:30    72.8    88.9    58.8
15:11:31    74.3    91.5    61.6
15:11:32    63.7    79.9    48.8
15:11:33    60.6    77.7    44.4
15:11:34    70.2    86.4    58.2
15:11:35    68.0    77.1    56.8
15:11:36    71.6    89.7    59.6
15:11:37    68.0    87.1    56.8
    
```

931170/2e

Fig.5.2 Printer output format with short heading (results logged every 1s)

```

-----
    Bruel & Kjaer
    SLM Type 2236

SETTINGS:
-----
F           50-130 dB
RMS: A     Peak:C

LOGGED RESULTS:
-----
12 Apr 1993    08:35:50

LAV5
[dB]
73.8
78.6
76.1 P
75.1
78.1 O
77.7
72.8
74.3 P O
63.7
69.3
60.6
70.2
    
```

931178/1e

Fig.5.3 Printer output format with short heading (results logged every 0.1s)

Chapter 5—Storing and Transferring Results Setting up the Output Formats

“P” indicates that there has been a pause during that logging interval (see section 5.8).

“O” indicates that there has been an overload (OVL) during the logging interval.

Printer (24 character/line)

You must use this format when you use Graphics Printer Type 2318. It uses a special character set (also for overall results). Do not use this format with any other type of printer.

“P” indicates that there has been a pause during the logging (see section 5.8).

“O” indicates that there has been an overload (OVL) during that logging interval.

“&” indicates that there has been both a pause and an overload (OVL) during the logging interval.

Printer (24 character/line) output format when results have been logged every 0.1s is the same as the Printer output format (see Fig. 5.3).

Spreadsheet

A comma-delimited format (i.e. all text is in inverted commas) and data are separated by commas) for use with spreadsheet programs (e.g. Excel).

```
"2236"  
"12 Apr 1993"  
  
"1"  
"F"  
"RMS:A", "Peak:C"  
"50-130 dB"  
  
"Time", "LAVS", "L10", "L90", "Pause", "OVL"  
"15:11:19", 73.8, 82.0, 65.7  
"15:11:20", 78.6, 89.1, 69.0, "P"  
"15:11:24", 76.1, 86.8, 66.5  
"15:11:25", 78.4, 92.3, 70.6  
"15:11:26", 75.1, 91.2, 73.7, "P", "O"  
"15:11:28", 78.1, 93.5, 73.9  
"15:11:30", 72.8, 88.9, 68.8  
"15:11:31", 72.8, 88.9, 68.8  
"15:11:32", 74.3, 91.5, 71.6  
"15:11:33", 63.7, 79.9, 58.8  
"15:11:34", 70.2, 88.4, 68.2  
"15:11:35", 60.6, 77.7, 54.4  
"15:11:36", 70.2, 88.4, 68.2  
"15:11:37", 68.0, 87.1, 66.8
```

Fig.5.4 Spreadsheet output format with short heading (results logged every 1s)

"P" indicates that there has been a pause during the logging interval (see section 5.8).

"O" indicates that there has been an overload (OVL) during the logging interval.

Chapter 5—Storing and Transferring Results Setting up the Output Formats

```
"2236"  
"12 Apr 1993", "15:11:19"  
  
"0.1"  
"A"  
"50-130 dB"  
  
"LAV5", "Pause", "Cv1"  
  
73.8  
78.6  
66.1, "P"  
78.4  
75.1, "O"  
78.1  
72.8, "P", "O"  
74.2  
63.7  
60.6  
70.2
```

9311807e

Fig. 5.5 Spreadsheet output format with short heading (results logged every 0.1s)

5.5.3 Level Distribution

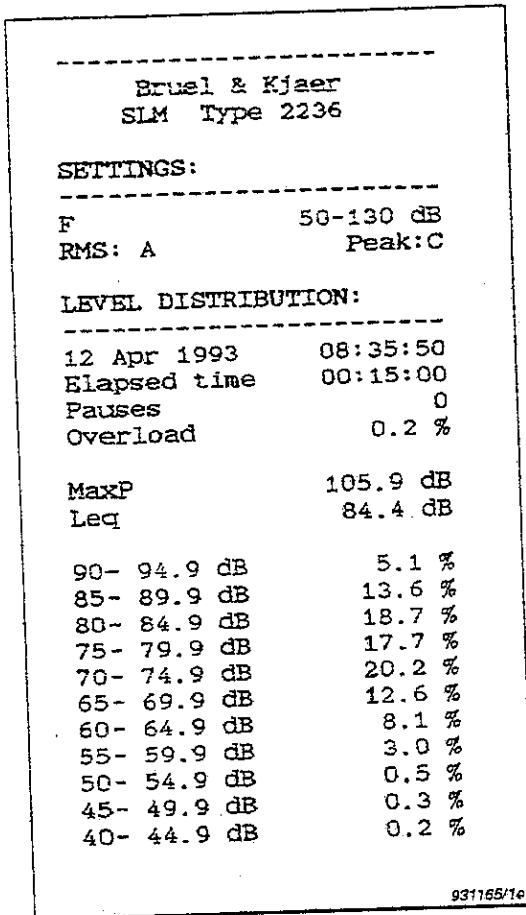

Level distribution is available with 1 or 5 dB resolution. It contains the following information:

- The number of pauses
- The percentage of the measurement time during which the sound level meter was overloaded (OVL)
- MaxP
- LAV parameter
- The level distribution (i.e. the percentage of the measurement time during which the SPL was within a certain dB range)
- If there has been an underload, the percentage of the measurement time during which the sound level meter was underloaded

All values are to one decimal place.

Fig. 5.6 Level Distribution output format with a short heading

5.5.4 Cumulative Distribution

```
-----  
Bruel & Kjaer  
SLM Type 2236  
  
SETTINGS:  
-----  
F 50-130 dB  
RMS: A Peak:C  
  
CUMULATIVE DISTRIBUTION:  
-----  
12 Apr 1993 08:35:50  
Elapsed time 00:15:00  
Pauses 0  
Overload 0.4 %  
  
MaxP 105.9 dB  
LAV5 84.4 dB  
  
95 dB 5.1 %  
90 dB 18.7 %  
85 dB 37.4 %  
75 dB 55.1 %  
70 dB 75.3 %  
65 dB 87.9 %  
60 dB 96.0 %  
55 dB 99.0 %  
50 dB 99.5 %  
45 dB 99.7 %  
40 dB 99.8 %  
Underload 100.0 %  
  
53716771e
```

Contains the following information:

- The number of pauses
- The percentage of the measurement time during which the sound level meter was overloaded (OVL)
- MaxP
- L_{AV} parameter
- The cumulative distribution (i.e. the percentage of the measurement time during which the SPL was over a certain dB level)
- If there has been an underload, the percentage of the measurement time during which the sound level meter was underloaded

All values are to one decimal place.

Cumulative distribution is available with 1 or 5dB resolution.

Fig.5.7 Cumulative Distribution output format with a short heading

5.5.5 Checking and Changing the Output Formats

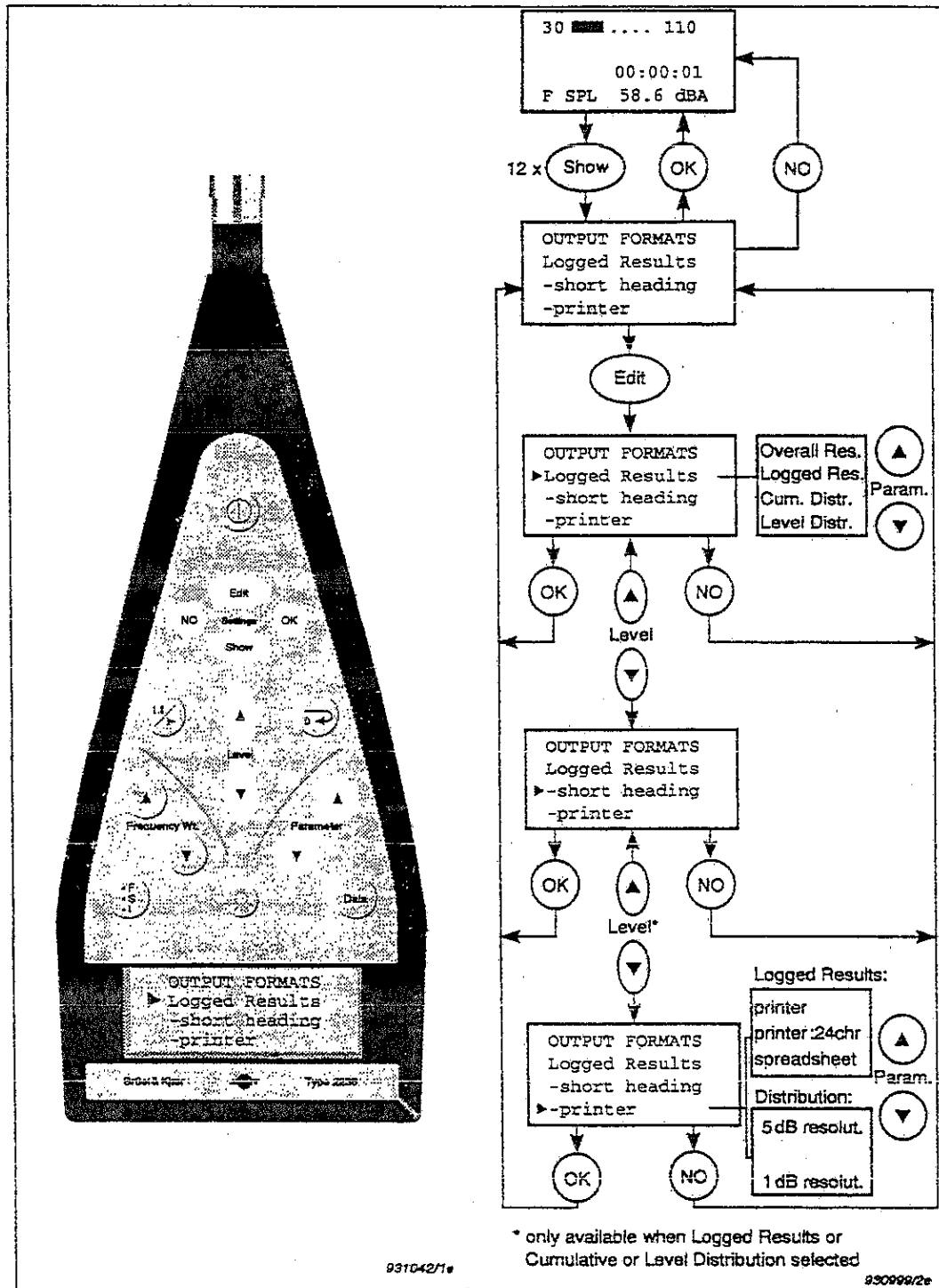

5.6 Printing

You can print results directly from the sound level meter by using any of the following printers:

- Portable Printer Type 2322
- An IBM® Proprinter compatible serial printer
- Graphics Printer Type 2318.

The baud rates (see section 5.4) of the sound level meter and the printer must be the same to enable them to communicate without losing or corrupting data.

Warning! When connecting the sound level meter to a printer, ensure that both the printer and the sound level meter are switched off. Otherwise the instruments could be damaged. Note that this does not apply to Portable Printer Type 2322, since it does not have a power switch.

To print:

1. Connect the printer to the sound level meter via the **Serial Interface** socket on the base of the sound level meter. Use one of the following cables:
 - For Portable Printer Type 2322, use Interface Cable AO 0532 (supplied with printer).
 - For serial printers with a 25-pole interface, use 9-pole Cable with 25-pole Adaptor AO 1386
 - For serial printers with a 9-pole interface, use 9-pole Cable with 25-pole Adaptor AO 1386, but remove the adaptor.
 - For IBM® Proprinter compatible parallel printers, use Interface Module UL 0064.
 - For Graphics Printer Type 2318, use Interface Cable AO 0404.
2. The communications settings (baud rate and handshake) on the sound level meter must match those of the printer.

If you are using Portable Printer Type 2322, then set the 2236 to 9600 baud and XON/XOFF handshake (see section 5.4 for instructions). If you are using another printer, please refer to your printer manual for settings.

3. Set up the Output Format of the results you want to print (see section 5.5). If you are using Portable Printer Type 2322 or an IBM[®] Proprinter compatible, select "Printer". For printing on a Graphics Printer Type 2318, select "Printer (24 char./line)".
4. Set the sound level meter in Pause mode and follow the instructions given in the figure below.

The printer prints the selected results in the selected output format (see section 5.5).

To stop printing:

To stop printing at any time, press <NO>. This will stop printing immediately and delete all unprinted data from the printer's buffer.

Chapter 5 – Storing and Transferring Results Printing

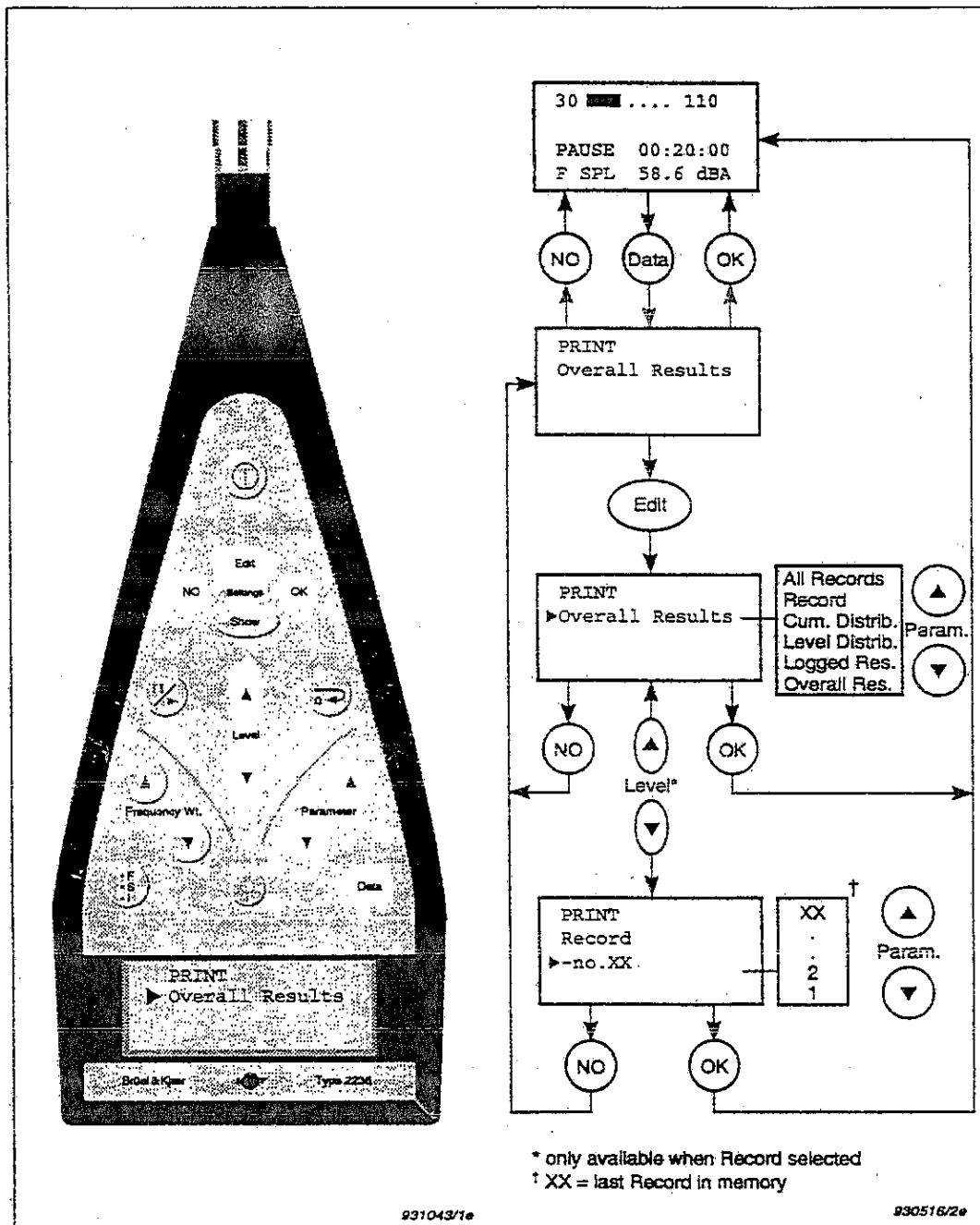

Errors

If the printer does not print out, check:

- The baud rates and handshake of the sound level meter and printer. If they are not the same, switch the printer off, correct the sound level meter's baud rates and handshake (see section 5.4) so that they are the same as the printer's and switch the printer on again (some printers only check the interface while switching on).
- The interface cable between the sound level meter and the printer

If neither of these steps work, consult your local Brüel & Kjær service representative.

5.7 Transferring Results to a Computer

You can also control the sound level meter from a computer (see section 8.4).

Warning! When connecting the sound level meter to the computer, ensure that both the computer and the sound level meter are switched off. Otherwise the instruments could be damaged.

To transfer:

1. Connect the computer to the sound level meter via the **Serial Interface** socket on the base of the sound level meter using 9-pole Cable with 25-pole Adaptor AO1386. If the computer has a 9-pole interface socket, remove the adaptor.
2. Start a communications program (e.g. BK-Link, Pro-Comm, or Brüel & Kjær Reporter or Brüel & Kjær dB2XL) on the computer. If you are using Reporter or dB2XL, then please refer to your Reporter or dB2XL documentation for more information.

Chapter 5—Storing and Transferring Results Transferring Results to a Computer

3. Configure the computer as follows:

9600 Baud
8 data bits
1 stop bit
Parity: none
Handshake: XON/XOFF

4. On the computer, enter the name of the file to which you want the results to be transferred (see the instruction manual for the communications program).

5. Set the sound level meter's baud rate to 9600 and its handshake to XON/XOFF (see section 5.4).

The baud rates and handshake of the sound level meter and the computer must be the same to enable them to communicate without losing or corrupting data.

6. Set up the Output Format of the results you want to transfer (see section 5.5). If you are using Reporter or dB2XL, or will be using the Logged Results in a spreadsheet program, select the Spreadsheet format.

7. Set the sound level meter in Pause mode and follow the instructions given in the figure below.

Chapter 5 – Storing and Transferring Results

Transferring Results to a Computer

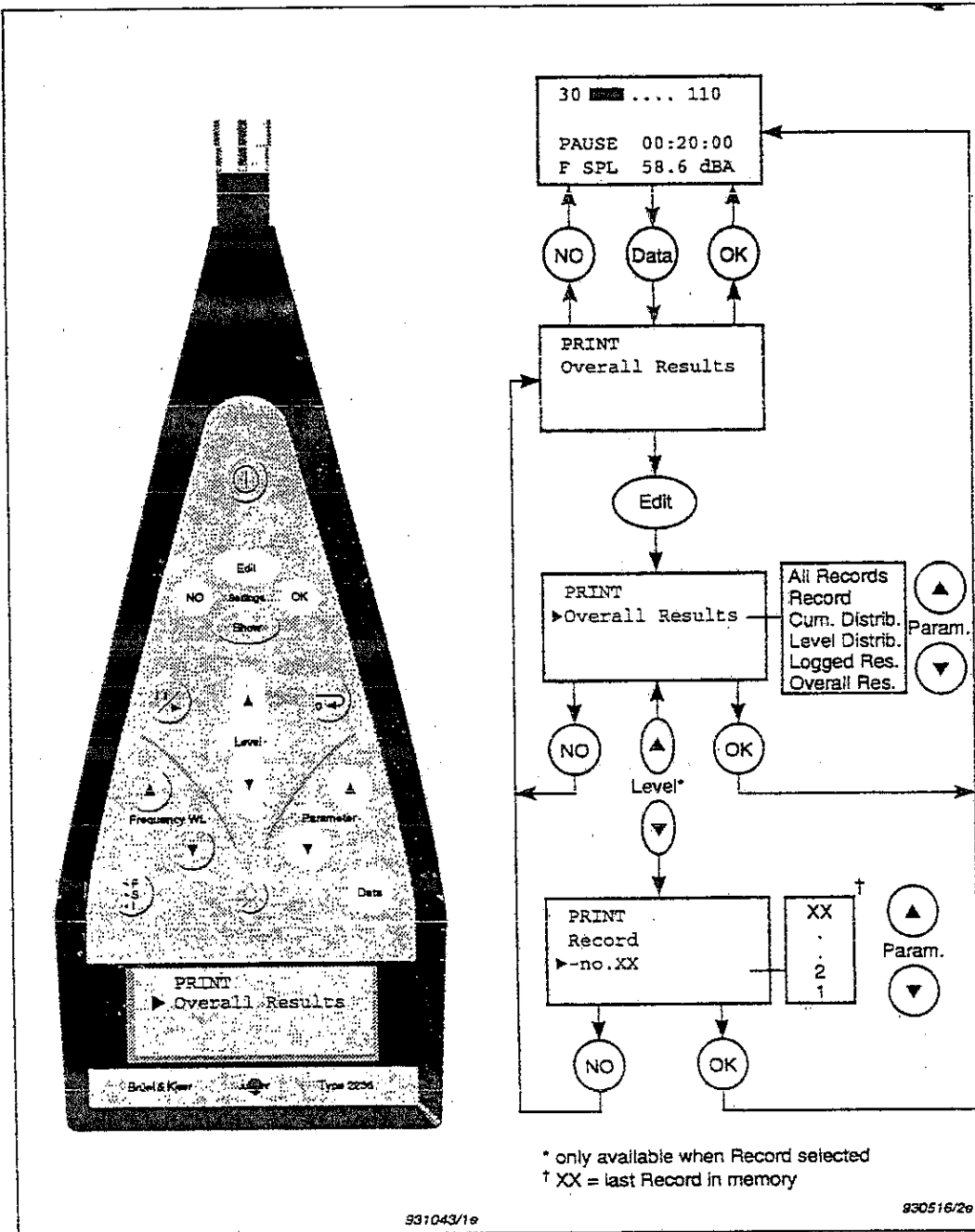

Chapter 5 – Storing and Transferring Results Interpreting the Log Times

The results are transferred to the computer under the name you have chosen from the computer program.

- If you have used a standard communications program to save the data as a spreadsheet file, then you can import the results into a spreadsheet program (e.g. Microsoft Excel).
- If you are using Brüel & Kjær Reporter software, then the data will be displayed in Reporter.
- If you are using Brüel & Kjær dB2XL, then the data will automatically be displayed in Microsoft Excel.

Errors

If the results are not transferred, check:

- The baud rates and handshake of the sound level meter and computer. If they are not the same for both, change the configuration of the computer so that the settings match those for the sound level meter.
- Which port is used on the computer
- The interface cable between the sound level meter and the computer

If none of these steps work, consult your local Brüel & Kjær service representative.

5.8 Interpreting the Log Times

When logged data is displayed, each log is tagged with the time the measurement was taken. Sometimes, you may pause measurement while logging readings, which may cause some confusion when interpreting your log. This section gives examples that show how to interpret your time readings.

Assume that the sound level meter is set to log at regular intervals of 10 seconds. The times attached to the logged data use the following rules:

- In the print-out, the times always refer to the start of a measurement interval.

- When a pause is activated (for example, 3 seconds after a measurement interval has started) the measurement will immediately stop. When pause is deactivated, the measurement will continue and ends when a total of 10 seconds has expired (7 seconds later). This is independent of the duration of the pause. The measurement interval therefore has been broken into two parts with a pause in between (see Fig. 5.8).
- Time periods in which a pause has occurred will be marked with a P in the print-out. For example, the measurement marked :22P in Fig. 5.8.

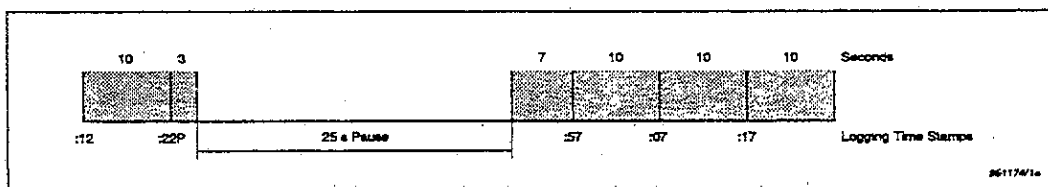

Fig. 5.8 An example of logging times with pause intervals

5.9 Recording on a DAT-recorder

Recording signals on a DAT-recorder via the sound level meter is useful for getting a calibrated recording for full analysis of impulsive noise or for examining the noise for pure tones. Also, later on, you can listen to the signal in order to be able to identify certain events such as a barking dog or slamming door.

To record:

1. Connect the DAT recorder to the sound level meter via the AC Out socket on the base of the sound level meter using LEMO to BNC Cable AO0403.
An adaptor may be required for the input sockets of certain DAT-recorders.
2. Set the maximum input of the DAT-recorder to at least $500\text{mV}_{\text{rms}}$.

Chapter 5--Storing and Transferring Results Recording on a DAT-recorder

3. Set the sound level meter to a suitable range (one that covers the sound levels but does not cause overload)

It is important to do this to ensure that you know what range the recorded signal represents.

4. Start recording.
5. Record the calibration signal from the calibrator.
This will allow you to accurately adjust the sensitivity of the analysis equipment on playback.
6. Measure.
7. After measuring, record the calibration signal again.
8. Stop recording and switch the sound level meter off.

For more information on recording using a DAT-recorder, see the recorder's manual.

Errors

If the DAT-recorder does not record, check:

- The cable between the sound level meter and the DAT-recorder
- The DAT-recorder

If neither of these steps works, consult your local Brüel & Kjær service representative.

Chapter 5 – Storing and Transferring Results Recording on a DAT-recorder

Chapter 6

Specifications

6.1	Specifications.....	6-2
6.1	Ordering Information.....	6-10

Chapter 6 – Specifications

Specifications

6.1 Specifications

Standards:

Conforms with IEC 651 (1979) and IEC 804 (1985) Type 1, and IEC 1672 (Draft, June 1996) Class 1. Conforms with ANSI S1.4 – 1983 and Draft S1.43, 6th September, 1992 Type 11. Conforms with BS 5969 and BS 6698 Type 11.

1/1-octave filter set conforms with IEC 1260–1995, Class 1; ANSI S1.11–86, order 3, Type 1–D; and BS 2475 (1964). (Types 2236 C and 2236 D only)

Measuring Ranges:

Range (dB)	Max. Peak level	Upper limit (RMS) for signals with crest factor = 10 (20dB)
10 [†] – 90	93	73
20 [†] – 100	103	83
30 – 110	113	93
40 – 120	123	103
50 – 130	133	113
60 – 140	143	123

* Only available with Types 2236 C–007 and 2236 D–007 when filter selected.

† For linearity range specifications, see the table given under Noise Floor.

Noise Floor:

Under reference conditions:

	Frequency Weighting		
	A	C	Lin
Typical Noise Floor	17	18	23
Max. Noise Floor	20	20	26
Level at which noise floor causes a non-linearity of <0.4 dB	30	30	36
Level at which noise floor causes a non-linearity of <1 dB	26	26	32

At 40°C and 95% RH, add 2 dB to typical values and 3 dB to maximum values.

Includes preamplifier's electrical noise and microphone's thermal noise.

Parameters:

MaxL, MinL, MaxP, Peak, SPL, L_{eq}, L_{AV,4}, L_{AV,5}, L_{im}, SEL, IEL, L_{EP,d}, L_N (3 values with L₉₀, L₅₀ and L₁₀ as default) and Overload in % of measurement time

Resolution:

L_N Values: 0.5 dB

Other Parameters: 0.1 dB

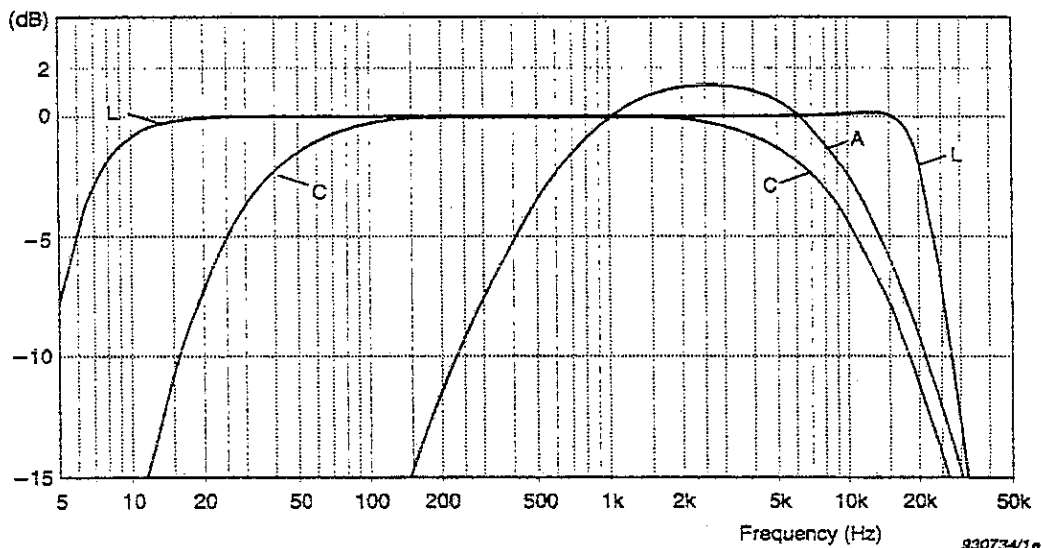
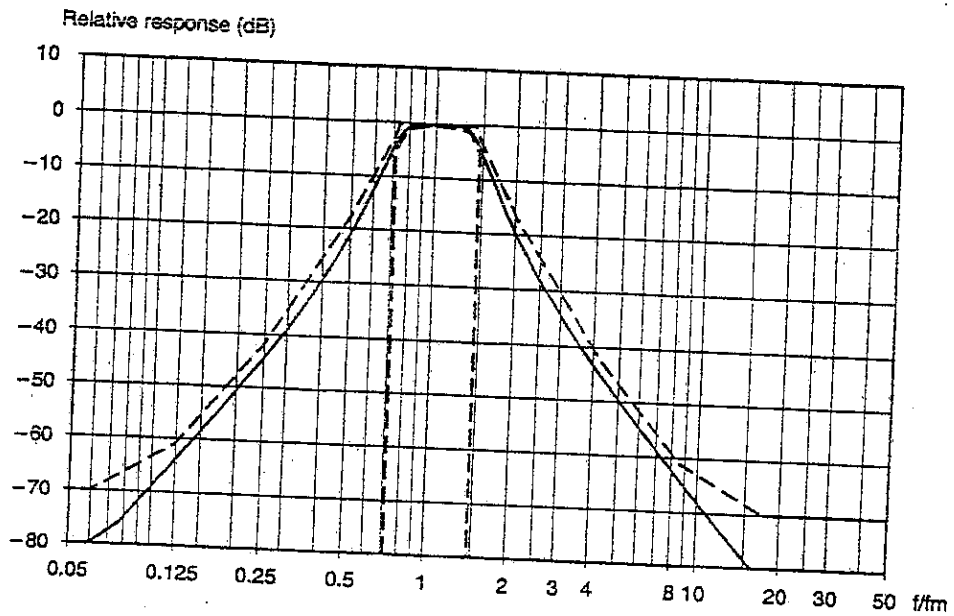

Fig. 6.1 Nominal frequency weighting characteristics

Chapter 6 – Specifications Specifications



932122/1e

Fig. 6.2 $1/1$ -octave filter characteristics as a function of frequency, f , against centre frequency, f_m . IEC tolerances are shown as dashed lines

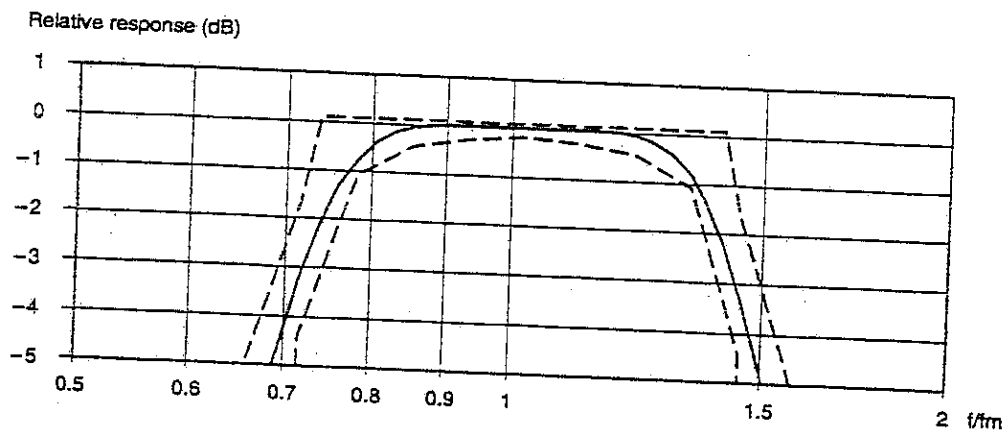

932123/1e

Fig. 6.3 $1/1$ -octave filter characteristics as a function of frequency, f , against centre frequency, f_m (detail of Fig. 6.2). IEC tolerances are shown as dashed lines

Chapter 6 - Specifications

Specifications

Frequency Weighting:

Selected independently for RMS and Peak

RMS:

A, C according to IEC651 Type 1

L: As shown in Fig.6.1 with Type 1 tolerances

Filter:

Band-pass Filters: Eight 1/1-octave filters at 1/1-octave intervals (base 10)

Centre Frequencies: 31.5, 63, 125, 250, 500Hz, 1, 2, 4, 8kHz

Characteristics: As shown in Figs.6.2 and 6.3

Peak:

C according to IEC651 Type 1

L: As shown in Fig.6.1 with Type 1 tolerances

Detectors:

Simultaneous RMS and Peak with independent frequency weightings

Linearity Range: 80dB

Pulse Range: 83dB

Non-linear Distortion: Too small to affect accuracy

Peak Detector Rise Time: <50µs

Time Weighting:

S, F, I according to IEC651 Type 1 (typically better than Type 0). See Fig.6.4

When Logging Every 0.1s: 12ms (indicated on the display by \square)

Display:

4 line LCD showing:

- Measuring range and quasi-analogue bar showing input signal

- Only available with Types 2236 C-007 and 2236 D-007 when filter selected.

- Battery low, pause and overload with hold indicators
- Time weighting and elapsed measurement time
- Frequency weighting (Peak or RMS) or filter centre frequency†, selected parameter with level

Optional back-light

The quasi-analogue bar is updated 10 times per second

Displayed parameter level updated each second

Exchange Rate:

3, 4 or 5dB

Reset:

Resets Buffer (including elapsed time) to zero
Warning prior to reset if elapsed time > 1min
Reset when changing Exchange Rate, frequency or time weighting

Resets all results in Log, Memory and Buffer if held down together with <Data>

Optional reset when changing level of measurement range (L_{NS} and distributions not available if range change is without reset)

Memory:

40 Records of Overall Results

Result Logging:

L_{eq}‡, L₁₀ and L₉₀

Logged Every: 0.1**, 1, 10s, 1, 10, 30min and 1hour

† Only available with Types 2236 C-007 and 2236 D-007 when filter selected.

‡ L_{eq}, L_{AV,4} or L_{AV,5}, dependent on Exchange Rate

** Only L_{eq}, L_{AV,4} or L_{AV,5} logged

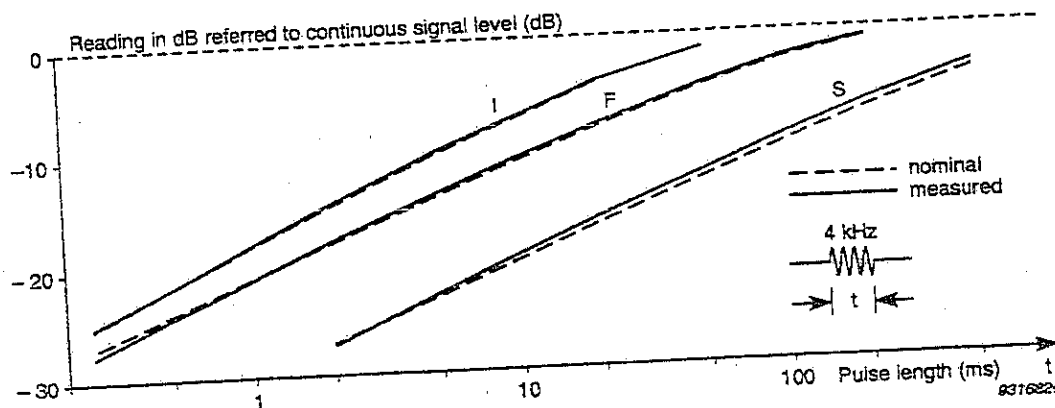

Fig.6.4 Response of the sound level meter to tone bursts of varying characteristics

Logged To: log or interface
Memory Capacity: 128KBytes (Types 2236 A-007 and 2236 C-007). Equivalent to 21600 sets of results (for example, 6h of 1s logging). 512KBytes (Types 2236 B-007 and 2236 D-007). Equivalent to 86400 sets of results (for example, 24h of 1s logging)

Microphone:

Type 4188 Prepolarized Free-field 1/2" Condenser Microphone

Sensitivity: -30dB re 1V/Pa ± 2 dB
Frequency Range: 8Hz to 12.5kHz ± 2 dB
Capacitance: 12pF

Serial Interface:

Compatible with EIA-574
Compatible with EIA-232-E with 25-pole adaptor
Baud Rate: 1200 - 19200
Data Bits: 8
Stop Bit: 1
Parity: None
Handshake: Hardwire, XON/XOFF, or None
Result Output Formats:
Overall and Logged Results, Level and Cumulative Distribution
Heading: Short
Output Format Types: Printer, Printer (24 char./line) or Spreadsheet
Distribution Resolution: 1 or 5dB

DC Output:

Short-circuit protected coaxial socket (LEMO series 00)
Output: 50mV/dB equivalent to 0 - 4V
Output Resistance: 100 Ω
Output: Sampled detector output
Updated: 160 times per second

AC Output:

Short-circuit protected coaxial socket (LEMO series 00)
Output: 0.5V RMS corresponding to the top of the selected measurement range ± 2 dB depending on the microphone's sensitivity
Output Resistance: 100 Ω
Signal: Output signal from preamplifier (L frequency weighting)

Clock:

Adjustable real-time (calendar) and measurement duration
Factory set to CET (GMT+1)

Warm-up Time:

<5s

Effect of Magnetic Field

80A/m (1 \AA sted) at 50Hz gives <34dB (L)

Vibration Sensitivity

<80dB with L-weighting at 1m/s⁻² horizontally
<85dB with L-weighting at 1m/s⁻² vertically

Calibration Conditions:

Reference Frequency: 1000Hz
Reference SPL: 94dB
Reference Temperature: 20°C (68°F)
Reference RH: 65%
Reference Range: 50-130dB (set automatically during calibration sequence)
Reference Direction of Incidence: Frontal
Correction with Extension Cable: 0dB

Environmental Effects:

Storage Temp.: -25 to +70°C (-13 to +158°F)
Operating Temp.: -10 to +50°C (14 to 122°F)
Effect of Temperature: <0.5dB (-10 to +50°C)
Effect of Humidity: <0.5dB for 30% <RH <90% (at 40°C, 1kHz)

Batteries:

Four 1.5V LR6/AA size alkaline cells
Lifetime (at room temperature): Typically >12h for Types 2236 A-007 and 2236 B-007. Typically >10h for Types 2236 C-007 and 2236 D-007
Internal back-up battery:
Charging time: -10hours (1st time)
Keeps clock and memories operating for at least 6months (typically) if fully charged

External Power Supply:

Must fulfil the following specifications
Voltage: regulated or smoothed 7-15V DC
Voltage Ripple: <100mV peak to peak
Maximum Current: 400mA
Average Current: -100mA at 7V
Socket:
Pin: Positive
Casing: Signal Ground
Pin Diameter: 2.0mm
External Diameter: 5.5mm

Physical Characteristics:

Size: 257x97x41mm
Weight: 460g (incl. batteries)

Chapter 6 – Specifications
Specifications

CE	CE-mark indicates compliance with EMC Directive
Safety	EN 61010-1 (1993) and IEC 1010-1 (1990): Safety requirements for electrical equipment for measurement, control and laboratory use
EMC Emission	EN 50081-1 (1992): Generic emission standard. Part 1: Residential, commercial and light industry EN 50081-2 (1993): Generic emission standard. Part 2: Industrial environment CISPR 22 (1993): Radio disturbance characteristics of information technology equipment. Class B Limits FCC Rules, Part 15: Complies with the limits for a Class B digital device
EMC Immunity	EN 50082-1 (1992): Generic immunity standard. Part 1: Residential, commercial and light industry RF immunity implies that sound level indications of 45 dB or greater will be affected by no more than ± 0.5 dB EN 50082-2 (1995): Generic immunity standard. Part 2: Industrial environment RF immunity implies that sound level indications of 60 dB (see note, below) or greater will be affected by no more than ± 0.5 dB
Note:	RF immunity is 14 dB better than the requirements given in IEC 1672 (Draft, June 1996) Class 1.

Frequency Response

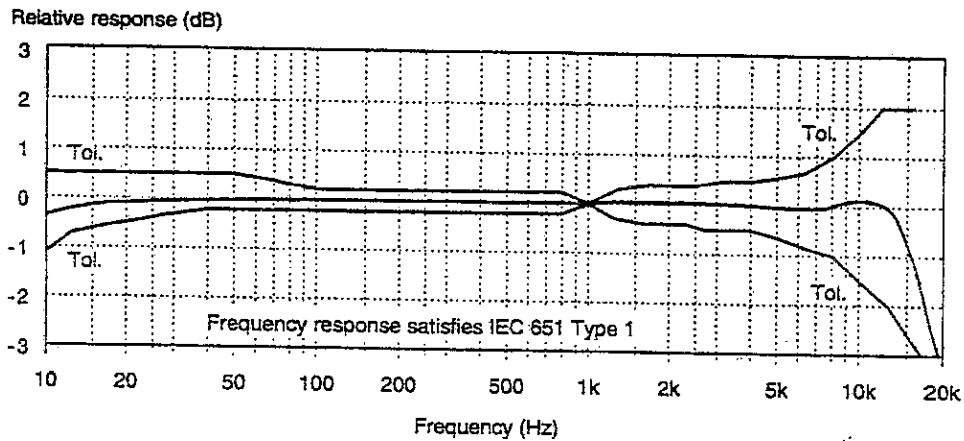

Fig.6.5 Typical free-field response of Microphone Type 4188 for 0° incidence without random incidence corrector

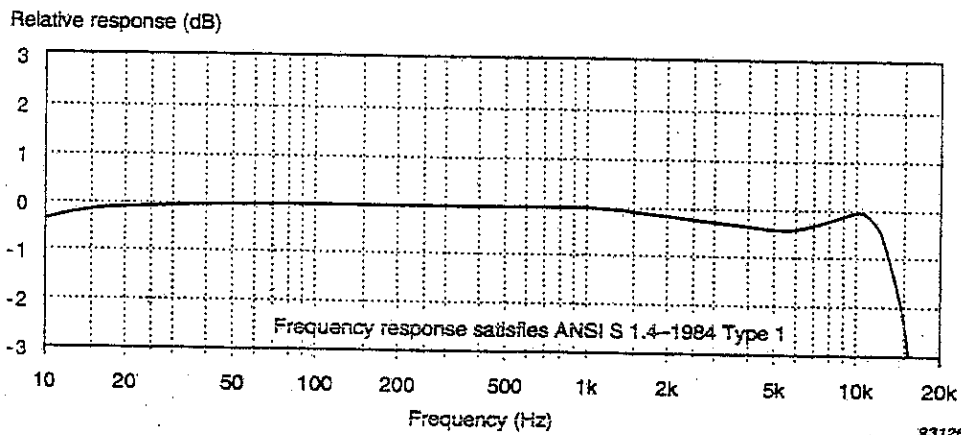

Fig.6.6 Typical diffuse-field response of Microphone Type 4188 with random incidence corrector

Directional Characteristics:

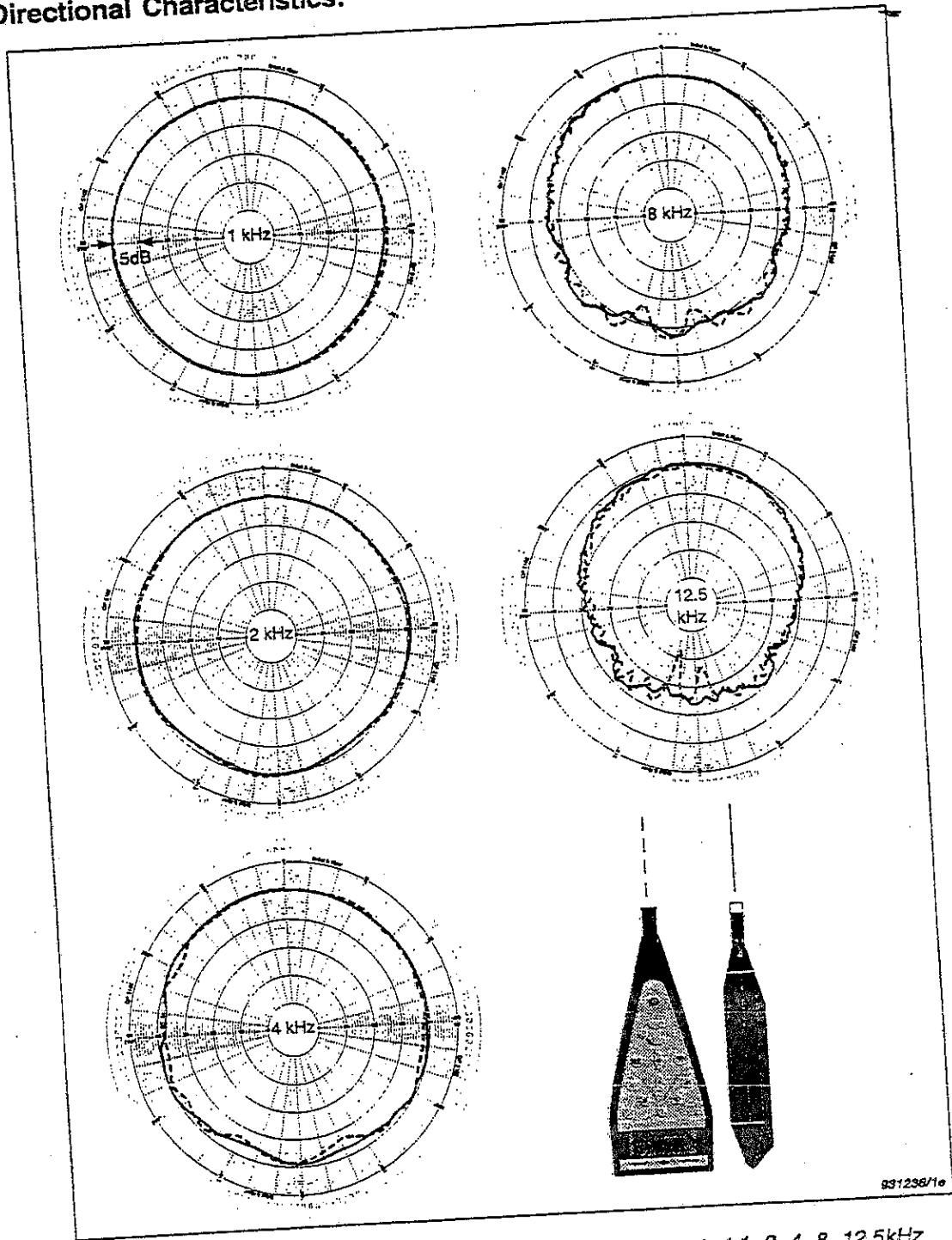

Fig.6.7 Directional characteristics of the complete instrument at 1, 2, 4, 8, 12.5kHz

Effect of Accessories

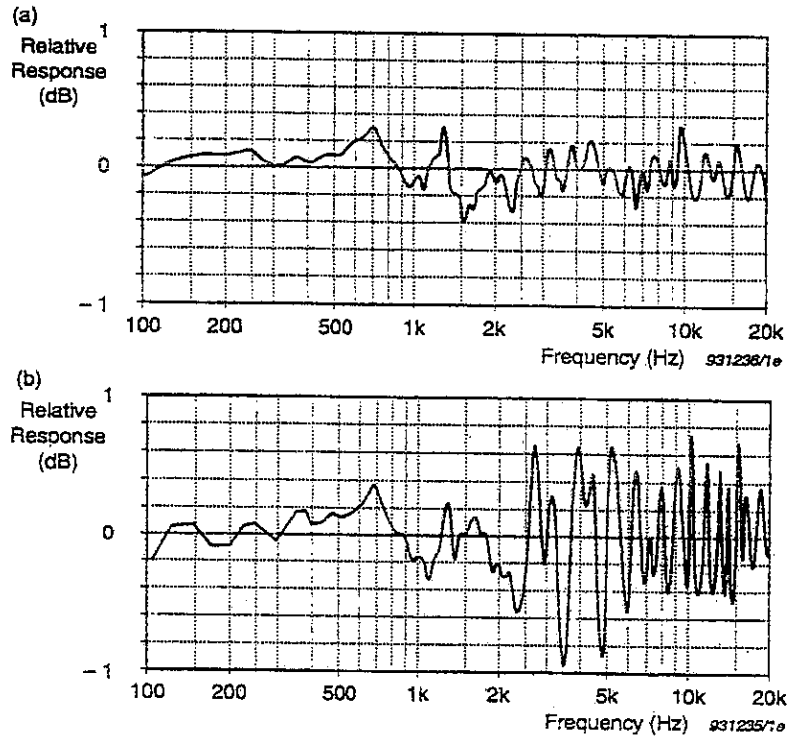

Fig.6.8 (a) Effect of the sound level meter's casing on its frequency response (for reference) compared to (b) the effect of Tripod UA0801 on the sound level meter's frequency response

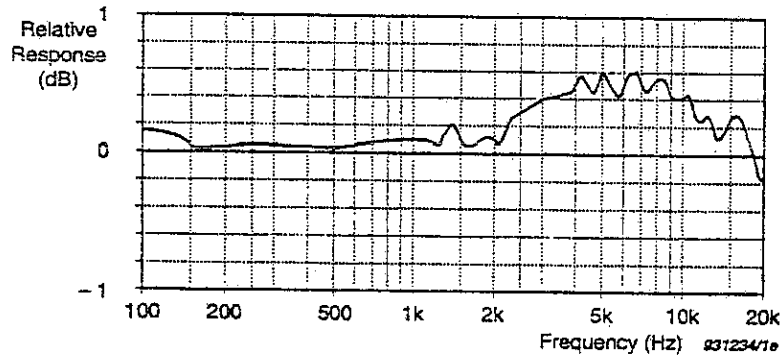

Fig.6.9 Effect of Protective Cover UA1236 on the sound level meter's frequency response

Chapter 6 – Specifications Ordering Information

6.1 Ordering Information

Type 2236A	Precision Integrating Sound Level Meter
Type 2236B	Precision Integrating Sound Level Meter (extended memory)
Type 2236C	Precision Integrating Sound Level Meter with 1/1 -octave filter set
Type 2236D	Precision Integrating Sound Level Meter with 1/1 -octave filter set (extended memory)

Includes the following accessories:

Type 4188:	Prepolarized Condenser Microphone Cartridge
KE0323:	Shoulder Bag
UA1236:	Protective Cover
4xQB0013	Four 1.5V LR6/AA size alkaline cells

Optional Accessories:

Type 4231:	Sound Level Calibrator
Type 4226:	Multifunction Acoustic Calibrator
Type 7694	Reporter Software
Type 7692	dB2XL Communication Macro for Microsoft Excel™
Type 2322	Portable Printer (includes connector cable AO 0532)
UA1251:	Tripod
UA0801:	Tripod
UA1254:	Microphone Holder (for tripod)
UA0237:	Windscreen (Ø 90 mm)
UA0459:	Windscreen (Ø 65 mm)
AO0408:	Microphone Extension Cable (3m)
AO0409:	Microphone Extension Cable (10m)
AO0403	LEMO to BNC Cable
AO1386	9-pole Cable with 25-pole Adaptor (for computer and serial printer)
UL 0064	Interface Module
ZG 0386	Power Supply for Europe
ZG 0387	Power Supply for UK
ZG 0388	Power Supply for USA
Upgrades:	
ZT0326	Octave Filter Set

Carrying Cases:

KE0325:	Carrying Case with insert for sound level meter, Sound Level Calibrator Type 4231 and Tripod UA1251
---------	---

Brüel & Kjær reserves the right to change specifications and accessories without notice.