



MT4100

BROADBAND CW TWT LAB AMPLIFIER
FOR RADAR, EMC AND EW TESTING

2.5 – 7.5 GHz 550W typ.

2.0 – 8.0 GHz 400W typ.

6.0 – 18.0 GHz 325W typ.

7.5 – 18.0 GHz 325W typ.

18.0 – 26.5 GHz 75W typ.

26.5 – 40.0 GHz 35W typ.



FEATURES:

Extensive Diagnostic Capabilities

Advanced Thermal Design

Compact Size

Ducted Cooling

Quiet Operation

The MT4100 broadband amplifier is leveraged around the field-proven MT4000 TWT architecture. With its modular design, compact and efficient packaging, the MT4100 will exhibit unsurpassed reliability.

New users will find the MT4100, with its intuitive front panel control, easy to utilize. For those environments where automation is required, the MT4100 offers a complete set of serial command in RS485 or RS232 for quick and easy hook-up to an automation system. MCL also offers a full line of controllers that will aid in remote operation.

AVAILABLE AMPLIFIER OPTIONS:

RF Input Attenuator

Other Options Are Available Upon Request

ISO 9001



MT4100

BROADBAND CW TWT LAB AMPLIFIER

ELECTRICAL SPECIFICATIONS	MT4100					
	535-2.5/7.5	450-2/8	300-6/18	250-7.5/18	50-18/26.5	40-26.5/40
Mechanical Configuration	Figure 1	Figure 1	Figure 2	Figure 2	Figure 2	Figure 2
Frequency Range (F ₀) Standard	2.5 - 7.5 GHz	2.0 - 8.0 GHz	6.0 - 18.0 GHz	7.5 - 18.0 GHz	18.0 - 26.5 GHz	26.5 - 40.0 GHz
Output Power (min.): HPA Rated Output (min.):	500 W (57.0 dBm)	2.0 - 2.5 GHz 125 W (51.0 dBm) 2.5 - 8.0 GHz 370 W (53.2 dBm)	250 W (53.7 dBm)	250 W (53.7 dBm)	45 W (46.5 dBm)	35 W (45.4 dBm)
HPA Typical Output:	550 - 825 W (57.4 - 59.2 dBm)	2.0 - 2.5 GHz 175 - 500 W (52.4-57.0 dBm) 2.5-8.0 GHz 475 - 725 W (56.8-58.6 dBm)	325 - 350 W (55.1-55.4 dBm)	320-350 W (55.1-55.4 dBm)	75-95 W (48.7-49.8 dBm)	35-65 W (45.4-48.1 dBm)
Gain:						
Large Signal (min.):		60 dB			45 dB	50 dB
Small Signal Gain (SSG) (min.):		63 dB			50 dB	60 dB
Attenuation Range with optional SSA:			20 dB			
Maximum SSG Variation Over:						
Full Band:	15 dB max. (7 dB max. with equalizer)		12 dB max. (5 dB max. with equalizer)		20 dB max.	
Gain Stability:		±0.25 dB/24 hr. max (constant drive, line voltage and temp.)				
Stability, Any Freq. 0 to +40°C:		6.0 dB typ.				
Stability, Any Freq. ±10° Max.:		1.2 dB typ.				
Input VSWR:	2.0:1 max. with respect to 50 ohms					
Output VSWR:	2.5:1 typ.					
Load VSWR:	2.0:1 max. without damage, continuous					
Residual AM Noise, Max.:						
To 10 kHz			40 dBc max.			
10 - 500 kHz			-20 (1.0 + Log f kHz) dBc			
Above 500 kHz			57 dBc max.			
Harmonic Output, Max.:	-4 dBc					
Noise & Spurious, Max.:						
Transmit Band (F ₀)	-70 dBm/Hz					
Prime Power:						
Voltage:	180 - 264 VAC, single phase		100 - 264 VAC, single phase			
Power Consumption:	2.7 KVA max.		1.9 KVA max.		900 VA max.	800 VA max.
Power Factor:	0.95 min.					
In-Rush:	28A max.					
Input Transients:	EN61000-4-4, 4-5, 4-11 (Surge, Fast Transients, Line Dropout)					

Note: Performance information is subject to change without notification. Contact MCL for the latest specifications (TN4100-1).

RF BLOCK DIAGRAM

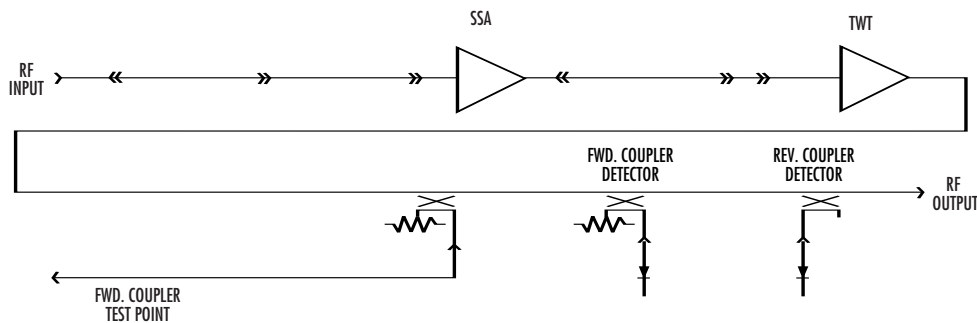

CONTROL AND STATUS CAPABILITIES

TYPE	FUNCTION		
Controls	Filament ON/OFF Transmit/Standby *RF ON/OFF Reset *Attenuation	Units Select *Hold Power ON/OFF Auto Switching (1:1) Manual Switching (1:1)	Fault Counter ON/OFF Antenna Position (1:1) Load Position (1:1) Local/Remote/Computer
Adjustable Parameters	*Auto Power Tube Temperature Alarm RF Low Alarm Comm Address Date	RF Reflected Power Alarm RF High Alarm Comm Band Rate Time	RF Reflected Power Fault Filament Under Current Fault Comm Protocol
Displays	RF Forward Power Helix Voltage Filament Delay	Helix Current Tube Temperature	RF Reflected Power Filament Current PS Temperature
Faults (Notification, RF & HV Shutdown)	Tube Temperature Switch Tube Temperature Analog Helix Run Current HV Under Voltage User Interlock	WG Pressure Helix Surge Current HV Over Voltage	PS Temperature Chassis Interlock Filament Under Current
Alarms (Notification Only)	RF High RF Reflected Blower Failed Exciter	RF Low Tube Temperature AC Low Line	PS Temperature RF Switch Failed
Additional Status	Delay Summary Alarm Computer Tx Remote Rx Maintenance Log	Transmit Selected Summary Fault Computer Rx Event Log	Sampler Port Cal Table RF Low Switching ON/OFF Remote Tx Fault Log

* Optional

ENVIRONMENTAL SPECIFICATIONS

Operating Temperature:

-10°C to +40°C

Non-Operating Temperature:

-40°C to +70°C

Relative Humidity:

95%, non-condensing

Operating Altitude:

10,000 ft. above sea level (3,048 m)
with standard adiabatic derating

Non-Operating Altitude:

50,000 ft. above sea level (15,240 m)

Vibration:

Method 514.4 of
MIL-STD-810E Procedure I, Figures 514.4-1,
514.4-2, 514.4-3

Shock:

10 g, 11ms

MECHANICAL SPECIFICATIONS

RF Connectors:

Input: Type SMA female
Output: 2.0–8.0 GHz SC (Male)
6.0 – 18.0 WRD-650
7.5 – 18.0 WRD-750

Installed Weight:

Figure 2: 65 lbs.
Figure 1: 90 lbs.

Cooling:

Closed Loop Circuit



MT4100

OUTLINE DRAWINGS

Figure 1

535W – 2.5/7.5 GHz
450W – 2/8 GHz

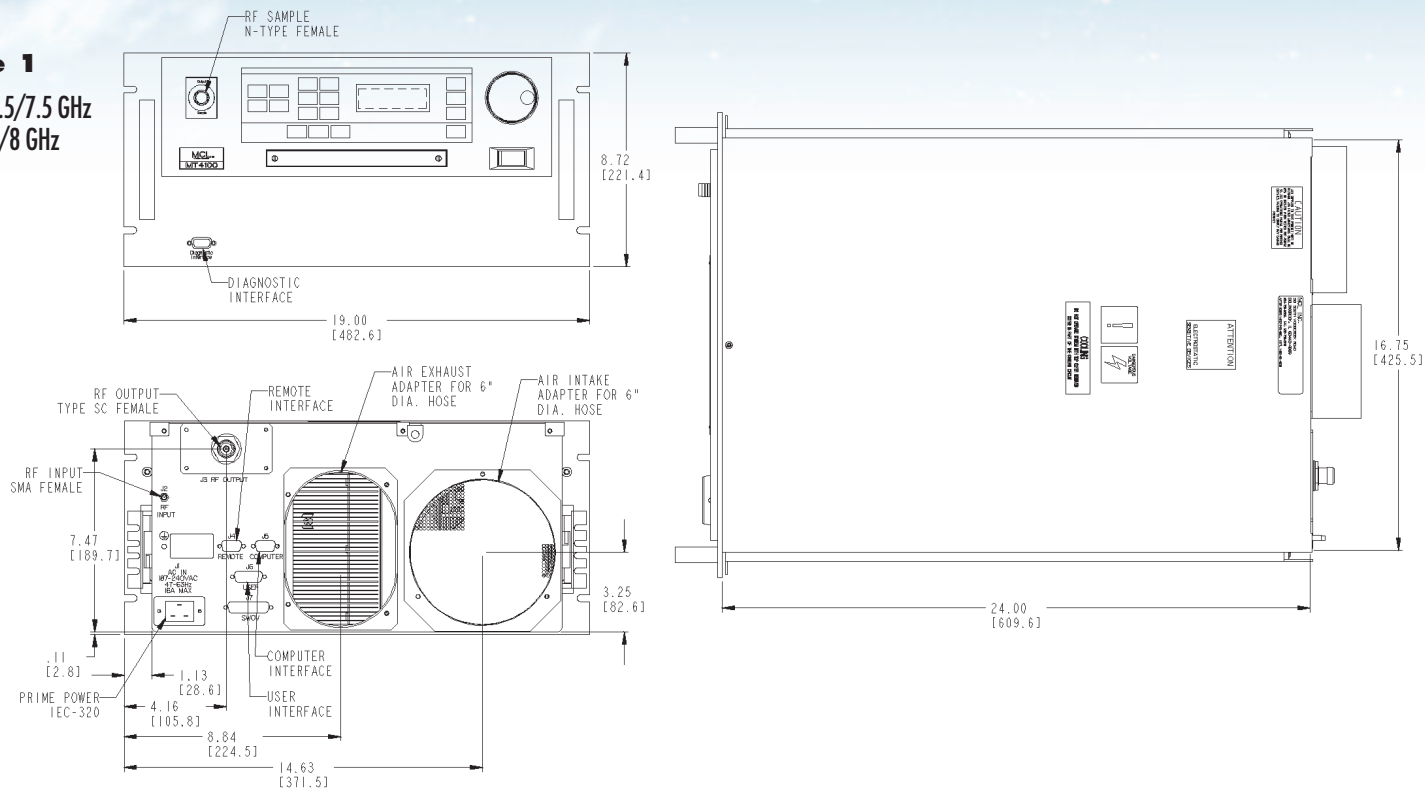

Note: Mechanical dimensions are frequency band dependent.

Figure 2

300W – 6/18 GHz
250W – 7.5/18 GHz
50W – 18/26.5 GHz
40W – 26.5/40 GHz

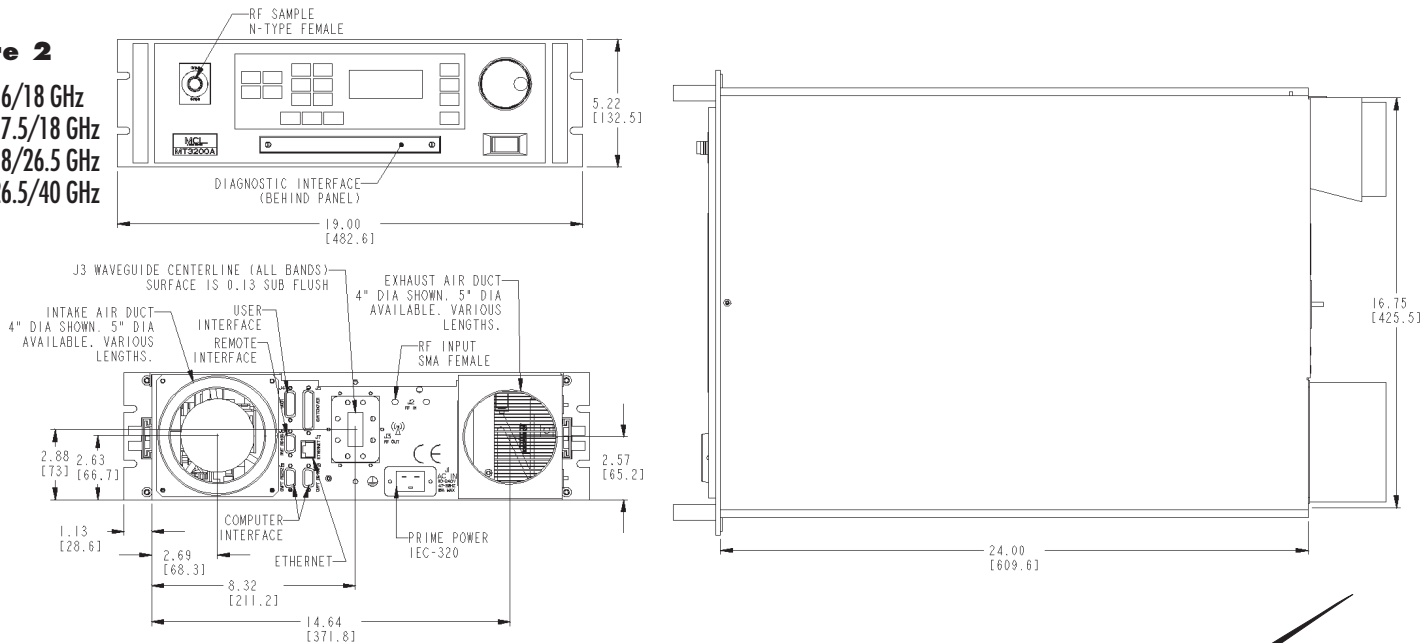

MCL, INC • 501 S. Woodcreek Drive, Bolingbrook, IL U.S.A., 60440-4999 • 630-759-9500 FAX: 630-759-5018
24-HOUR CUSTOMER SUPPORT NUMBER IN THE USA: 1-800-743-4625
OUTSIDE THE USA: 312-461-4536

MITEQ • 100 Davids Drive, Hauppauge, NY U.S.A. 11788 • 631-439-9220 Fax: 631-436-7430

