

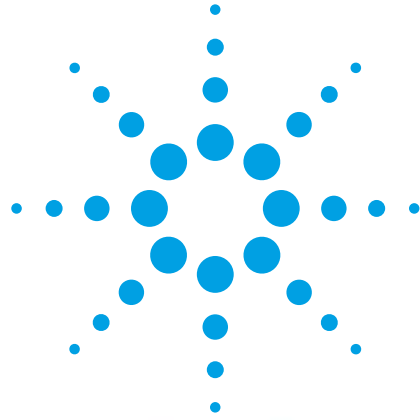

# Agilent Automotive Electronics

10 Application Notes on Design Debug  
and Functional Test



# **Automotive Electronics: 10 Application Notes on Design Debug and Functional Test**

## Introduction

If you are designing, manufacturing and testing automotive electronics, you face a lot of pressure. Most likely, you need to meet aggressive time-to-market goals. At the same time, you're juggling demands for higher quality, faster throughput and lower costs. We understand, and welcome the opportunity to help you develop and test your electronic products faster and within cost targets, while meeting your quality goals. We offer a broad set of robust test tools – the broadest offering in the automotive electronics test industry – to help you.

We assembled this collection of application notes to give you insight into how some of our test products can help you. Whether you want to shave milliseconds from your test throughput times or find a new way to uncover signal integrity problems in an automotive serial bus, we trust you'll find some nuggets here that will make your job easier.

You can count on Agilent, the premier test vendor for automotive electronics test.

Best regards,

Kari Fauber  
Agilent Automotive Initiative Manager

## **Automotive Electronics Design Debug**

---

Application note 1: *Using an Agilent 6000 Series MSO to Debug an Automotive CAN Bus*

## **Automotive Electronics Functional Test**

---

Application note 2: *Increase Automotive ECU Test Throughput*

Application note 3: *Automotive Electronic Functional Test Using Agilent System Components*

Application note 4: *Testing Antilock Brakes and Traction Control with the Agilent TS-5000 Family of Automotive Electronics Functional Test Systems*

Application note 5: *Testing Remote Keyless Entry Systems with the Agilent TS-5000 Family of Automotive Electronics Functional Test Systems*

Application note 6: *Testing Supplemental Restraint Systems with the Agilent TS-5000 Family of Automotive Electronics Functional Test Systems*

Application note 7: *Using Agilent 6690A Series System DC Power Supplies for Automobile Battery Simulation*

Application note 8: *Agilent TS-5020 Tire Pressure Monitoring System (TPMS)*

Application note 9: *Agilent TS-5400 Series II Automotive Electronics Functional Test System*

Application note 10: *Agilent TS-5020 Automotive Electronics Functional Test Systems*

### Automotive Design Debug

---

#### Application note 1

##### ***Using an Agilent 6000 Series MSO to Debug an Automotive CAN Bus***

This application note shows a typical debugging methodology designed to uncover signal integrity problems in a CAN-based automotive system. We use an intermittent problem in an automatic windshield-wiper to illustrate how you can use a mixed signal oscilloscope (MSO) to more effectively and efficiently turn on and debug an embedded mixed-signal design in an automobile. You will see how to synchronize on and capture a CAN differential signal that digitally transmits analog sensor data to an ECU. We demonstrate how you can use an MSO to repetitively capture and measure the output amplitude of a remote analog input sensor, while also capturing multiple SPI control signals within the ECU.

### Automotive Functional Test

---

#### Application note 2

##### ***Increase Automotive ECU Test Throughput***

Every second of test time counts in the competitive automotive electronics marketplace. Testing at multiple bias voltage levels is a necessary but time-consuming part of ECU testing. Most system DC sources require significant time to change and settle to a new output setting, adding several seconds to the overall test time. Learn what you can do to reduce command processing time and output response time and decrease the number of output voltage transitions. The overall test time reduction you can achieve could have a significant impact on your cost of test.

#### Application note 3

##### ***Automotive Electronic Functional Test Using Agilent System Components***

This application note shows you how to use Agilent bench instruments to create a reusable functional test system for low-frequency automotive modules. The illustrated test system uses LAN as an effective and inexpensive way to transfer data among the instruments and connect to virtually any instrument (GPIB- and LAN-based instruments, synthetic instruments and cardcage instruments). The illustrated test system uses an Agilent 34980A multi-function switch measure unit as the core.

#### Application note 4

##### ***Testing Antilock Brakes and Traction Control with the Agilent TS-5000 Family of Automotive Electronics Functional Test Systems***

If you manufacture electronic control modules (ECMs) for antilock brake and traction control systems, you know that functional testing of your products is critical to ensure reliability and that reliability is directly related to safety. This application note discusses some manufacturing functional tests you can perform on your antilock brake and traction control system ECMs using the Agilent TS-5400 Series II electronics functional test platform, including testing variable reluctance sensors, characterizing wheel speed thresholds, characterizing solenoid driver electronics, verifying "smart driver" response, and testing pump motor drivers.

---

Application note 5

***Testing Remote Keyless Entry Systems with the Agilent TS-5000 Family of Automotive Electronics Functional Test Systems***

This application note discusses some of the manufacturing functional tests you can perform on remote keyless entry systems and immobilizers using the Agilent TS-5000 family test systems, including checking the signal strength of the key fob amplitude and center frequency, verifying transmitter leakage current during active RF transmission, verifying RKE functionality, measuring the time between pressing the key fob and the resulting action, and verifying proper orientation of the transponder IC in the key fob.

Application note 6

***Testing Supplemental Restraint Systems with the Agilent TS-5000 Family of Automotive Electronics Functional Test Systems***

Unlike other automotive electronics, airbags typically are built to operate only once, so running a full test of the airbag in production is virtually impossible. However, various manufacturing tests can help you ensure the reliability and system integrity of your supplemental restraint systems. The application note discusses some of the functional tests you can perform on supplemental restraint systems using the AgilentTS-5000 family test systems, including testing the ECM's serial communications; detecting sensor opens, shorts or shorts-to-chassis; verifying occupancy-sensor switch operations; testing the battery voltage; and testing the firing loop for airbag deployment.

Application note 7

***Using Agilent 6690A Series System DC Power Supplies for Automobile Battery Simulation***

The standard voltage for automobile batteries is moving to 42 V. However, because of load changes during the operation of the vehicle, that voltage may reach up to 60 V or go as low as 25 V. The new 42-V battery will have different requirements for duty cycle and total power capability than 12-V batteries have. Under start/stop scenarios of future vehicles, the number of starts and stops that the battery will endure could increase by a factor of more than 10. This loading puts more strain on the battery and other car components. Find out how you can use the Agilent 6692A power supply for simulating the battery under all loading conditions. This power supply can also be used to test electronic equipment while simulating actual battery voltage fluctuations.

Application note 8

***Agilent TS-5020 Tire Pressure Monitoring System (TPMS)***

Tire pressure monitoring is an important safety feature. Conventional TPMS modules consist of pressure and temperature sensors attached to each wheel, data transmitters and a central receiver. Testing the transmitter module involves checking the signal power level and frequency deviation (FSK), making burst measurements (ASK) and demodulating the ASK/FSK signal. Learn how the Agilent TS-5020 TPMS testing solution can help you accomplish these tasks and more.

Application note 9

***Agilent TS-5400 Series II Automotive Electronics Functional Test System***

Testing automotive ECMs requires an understanding of the design and manufacturing requirements. This product note discusses the general requirements for testing an automotive ECM and explains how the TS-5400 Series II test system can help you meet those requirements with "just enough test." It describes the benefits of using the TS-5400 platform and shows you how you can reduce test development time, save on capital expenditures and reduce total test cost, increase your flexibility and plan for future growth.

Application note 10

***Agilent TS-5020 Automotive Electronics Functional Test Systems***

Producing quality ECMs can be a challenge when you are trying to get your products to market quickly and deliver them at a competitive cost. This product note tells how the TS-5020 automotive electronics functional test system can help you get products to market faster and at a lower cost without sacrificing quality. It discusses the unique attributes of automotive functional testing, test requirements and methodologies, and the advantages of Agilent TestExec SL software, which comes with the TS-5020.



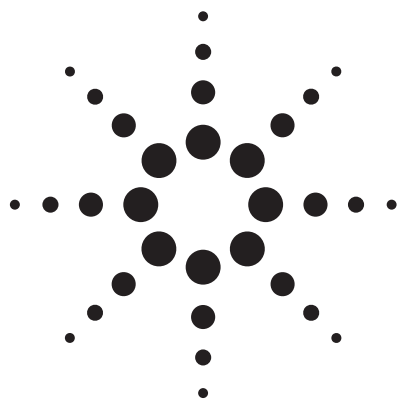

# Using an Agilent 6000 Series MSO To Debug an Automotive CAN Bus

Application Note 1576

<b>Table of Contents</b>	
<b>Introduction</b> .....	<b>2</b>
<b>What is an MSO?</b> .....	<b>3</b>
<b>Verifying proper operation of an automatic windshield-wiper system</b> .....	<b>4</b>
<b>Hardware-accelerated CAN decode reveals an infrequent problem</b> .....	<b>5</b>
<b>Triggering the MSO on error frames reveals a signal-integrity problem</b> .....	<b>6</b>
<b>Triggering the MSO on the random glitch reveals the source of the problem</b> .....	<b>8</b>
<b>Summary</b> .....	<b>9</b>
<b>Glossary</b> .....	<b>10</b>
<b>Related Literature</b> .....	<b>11</b>





# Introduction

To improve efficiency of system communication and to reduce cost, all of today's automotive designs employ a variety of serial bus communication protocols. The I<sup>2</sup>C and SPI protocols are most often used for chip-to-chip communication within electronic control units (ECUs). For long-haul serial communication between various automotive subsystems such as anti-lock brakes, airbag deployment, engine control, and GPS navigation, the CAN, LIN, and MOST protocols are the most popular serial buses implemented in today's vehicles, as shown in Figure 1. Unfortunately, long-haul communication is often susceptible to signal integrity problems caused by the naturally harsh environment found in automobiles, including signal interference from ignition systems and random system

noise, which can sometimes create errors during critical communication cycles.

By definition, automotive electronic systems are embedded mixed-signal systems because they feature multiple analog sensors and analog motor controls under digital control. For years, traditional oscilloscopes have been the primary tool-of-choice among automotive electronic system design engineers to measure the quality of both analog and digital signals. But traditional analog and digital oscilloscopes have many limitations, including lack of complex serial triggering and limited input channels of acquisition. However, a new class of measurement tools called mixed signal oscilloscopes (MSOs) offers many advantages for debugging and verifying

proper operation of today's automotive designs.

To illustrate the unique advantages of Agilent 6000 series MSOs, this application note shows a typical debugging methodology designed to uncover signal integrity problems in a CAN-based automotive system. While synchronizing on and capturing a CAN differential signal that digitally transmits analog sensor data to an ECU, the MSO was also used to repetitively capture and measure the output amplitude of a remote analog input sensor. At the same time, the MSO also was used to capture multiple SPI control signals within the ECU. But before we explore this particular automotive CAN design and explaining how the MSO was used to debug and discover a signal integrity problem, let's first define what we mean by "MSO."

**Figure 1:**  
Typical distributed automotive electronic system under serial bus control

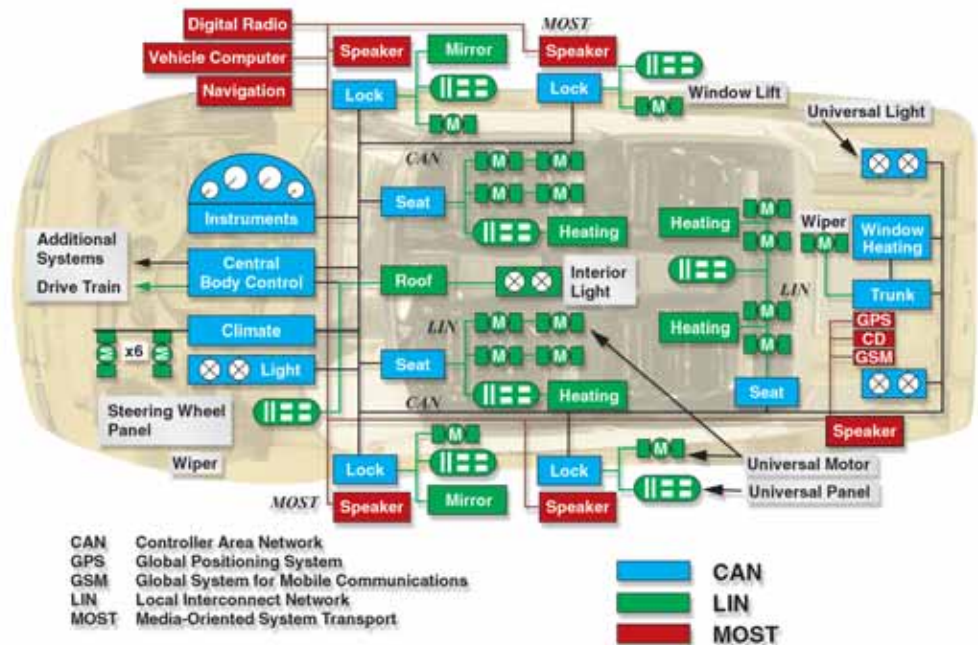



## What is an MSO?

An MSO is a hybrid test instrument that combines all of the measurement capabilities of a digital storage oscilloscope (DSO) with some of the measurement capabilities of a logic analyzer, along with some serial protocol analysis – into a single, synergistic instrument. With an MSO, you are able to see multiple time-aligned analog, parallel-digital, and serially decoded waveforms on the same display, as shown in Figure 2. Although many of today's traditional oscilloscopes have limited triggering capabilities, some of today's MSOs include sophisticated serial triggering and protocol decode analysis that are optimized for automotive electronic system debug.

MSOs typically lack the large number of digital acquisition channels of full-fledged logic analyzers and also lack the higher abstraction levels of analysis provided by serial protocol analyzers. But the relative simplicity of MSOs allows you to use them with ease and avoid the complexities involved in operating logic analyzers and protocol analyzers. In fact, one of the primary advantages of an MSO is its use model. You use an MSO in much the same way you use an oscilloscope. And because MSOs are highly integrated, they are much easier to use than loosely tethered two-box mixed-signal measurement solutions consisting of either a scope linked to a logic analyzer or

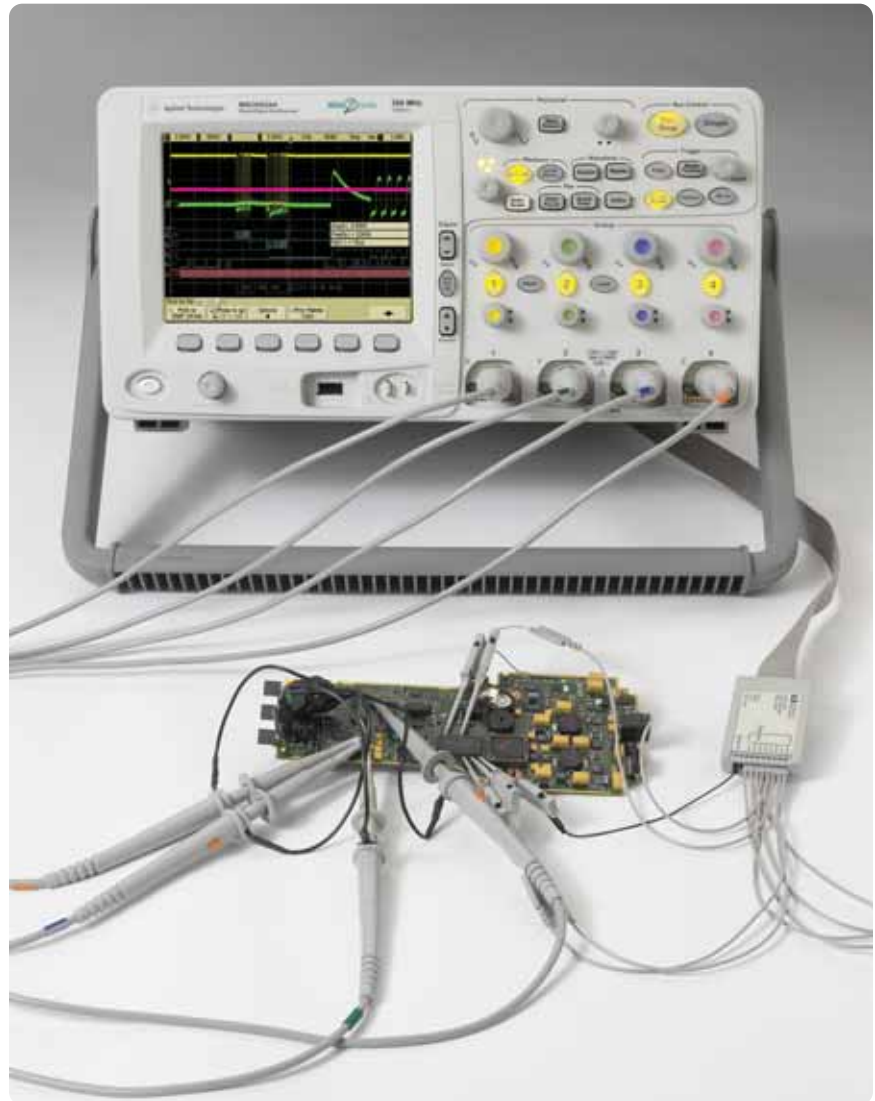

**Figure 2: Agilent's 6000 Series mixed signal oscilloscope (MSO)**

a scope linked to a serial bus protocol analyzer. A good MSO, such as Agilent's MSO6000, is user-friendly, provides fast waveform update rates, includes serial triggering and analysis, and operates much like an oscilloscope – not like a logic analyzer or protocol analyzer.

## Verifying proper operation of an automatic windshield-wiper system

Before integrating a new embedded design into an automobile, an Agilent MSO was first used in the lab environment to verify proper circuit and protocol operation of a prototype automatic windshield-wiper system. Figure 3 shows multiple time-correlated analog and digital signals from the prototype system captured and displayed on an MSO6104A. The channel-1 waveform (top trace) is the differential CAN bus signal that communicates to various remote subsystems including the windshield-wiper system. The channel-2 waveform (middle trace) shows the analog output signal level of a remote rain sensor that optically detects the amount of rain/snow striking the windshield. Also shown are various time-correlated SPI control signals (traces shown near the bottom of the scope's display) within the ECU including CLOCK, DATA, CS, and an INTERRUPT signal – all captured using some of the MSO's available sixteen logic-timing channels. The multi-colored bus trace at the bottom of this oscilloscope's display shows time-correlated decoded information of CAN packets captured on a user-selected CAN acquisition channel, which in this case was channel-1.

In this particular design, the instantaneous output amplitude of the remote analog sensor is converted to a digital value using an analog-to-digital converter (ADC), and then it is serially transmitted to the ECU as a single data byte within a particular data frame (07F<sub>HEX</sub>). To capture repetitive transmissions of this sensor's output and verify proper

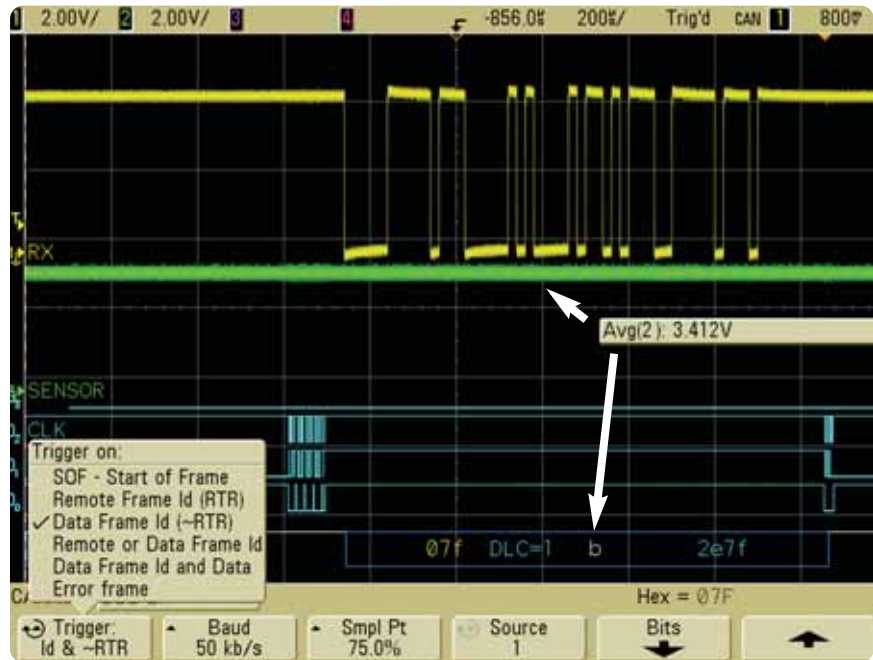

Figure 3: Capturing multiple SPI and CAN signals using an MSO with CAN triggering and decode

operation of the prototype, the MSO was initially set up to trigger on the CAN data frame 07F<sub>HEX</sub>, as shown in Figure 3. The analog sensor's output value is always transmitted in this frame. With this oscilloscope setup condition, the automotive design engineer was able to easily measure the analog amplitude of the sensor's output (3.41 V) while monitoring and verifying the data value (B<sub>HEX</sub>) that was actually transmitted within the CAN packet. While testing this prototype automatic wiper system in the lab, no problems were observed, and the CAN differential signal appears to be nearly noise-free.

Unfortunately, when this automotive subsystem was integrated into the automobile, the automatic wiper system performed unreliably, and it was determined that the data value received by the ECU did not always match the real-world physical condition of the analog moisture sensor. When circuit problems are predictable and repetitive, it can be a fairly easy task to isolate and track down the root cause of a circuit problem. But in this particular automotive design, once the design was integrated into the automobile, errant transmissions of data from the sensor were random and infrequent – making it difficult to isolate the cause of the problem.

## Hardware-accelerated CAN decode reveals an infrequent problem

Figure 4 shows the same signals that were originally measured in the lab, but this time the signals were captured with the automatic wiper system integrated into the automobile. We now see the influence of noise and interference on the differential CAN signal caused by the harsh environment in the vehicle. The automotive design engineer monitored the scope's display while repetitively triggering on data frame ID: 07F<sub>HEX</sub>. The engineer observed an occasional red "flash" within the CAN decode string (bottom trace), as shown in Figure 4. This MSO's CAN decode feature color-coded bad CRCs in red, and other frame error conditions are shown as a red bus trace. This scope's very fast waveform update rate (up to 100,000 real-time waveforms per second) and hardware-accelerated serial decode were critical to capturing the infrequent bad data transmissions. The hardware-accelerated serial decode displays decoded strings as fast as 60 updates per second – faster than the human eye can read, but slow enough to see color-coded error conditions if they occur infrequently.

Most oscilloscopes with deep memory and serial decode capabilities update very slowly. This is primarily because deep memory records are decoded using software post-processing techniques. Waveform and decode updates can sometimes take seconds. This

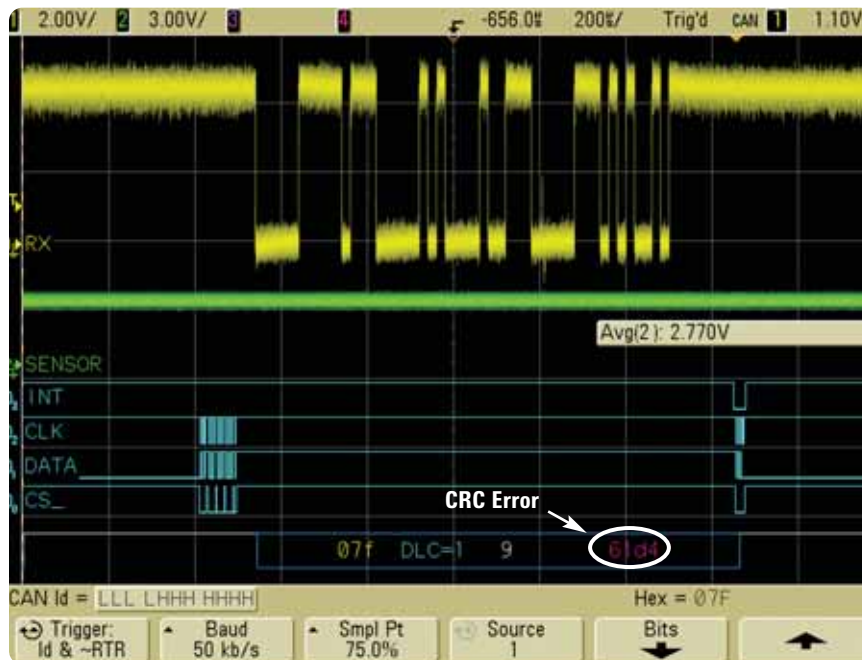

**Figure 4: Random errors observed in CAN decode while triggering on data frame ID: 07F<sub>HEX</sub>**

means that if errors occur infrequently, most error conditions will randomly occur during the scope's dead-time – not during the scope's acquisition time. This makes it nearly impossible to randomly capture an errant transmission with a traditional oscilloscope, even with CAN triggering and decode capabilities. But hardware-accelerated CAN decoding in the Agilent 6000 series MSO statistically enhanced the probability of catching random and infrequent error conditions, since both the waveform and CAN decode update rates exceeded the repetitive rate of occurrences of data frame 07F<sub>HEX</sub>.

To freeze the scope's display on just one occurrence of a "bad" data transmission, the design engineer first attempted to quickly press the scope's front-panel STOP key when a "red" decode string was observed. Unfortunately, the scope's waveform and decode update rate was so fast that by the time the STOP key was pressed, several subsequent acquisitions had occurred and the display always stopped on a "good" data transmission.



## Triggering the MSO on error frames reveals a signal-integrity problem

The next step was to setup the scope's triggering to synchronize only on error frames, as shown in Figure 5. With this trigger setup condition (trigger on error frame), the scope only captured and displayed "bad" CAN transmissions and ignored "good" transmissions. Now the engineer could either press the STOP key at any time to analyze the signal quality of the last "bad" transmitted CAN frame, or use the scope's single-shot acquisition mode to freeze the scope's display on the next "bad" data transmission. From this display (Figure 5), the engineer's first suspicion was that perhaps the random data transmission problems were due to excessive random noise that was coupling into the differential CAN signal (top trace). We can see that the noise riding on the CAN signal appears to have a Gaussian distribution as evidenced by the 256 levels of display intensity provided by this scope's MegaZoom III technology display system – similar to the display quality of a traditional analog oscilloscope. But after measuring the random noise level with the MSO's "standard-deviation" measurement, the engineer determined that the signal noise level was within specified tolerances and not inducing errors.

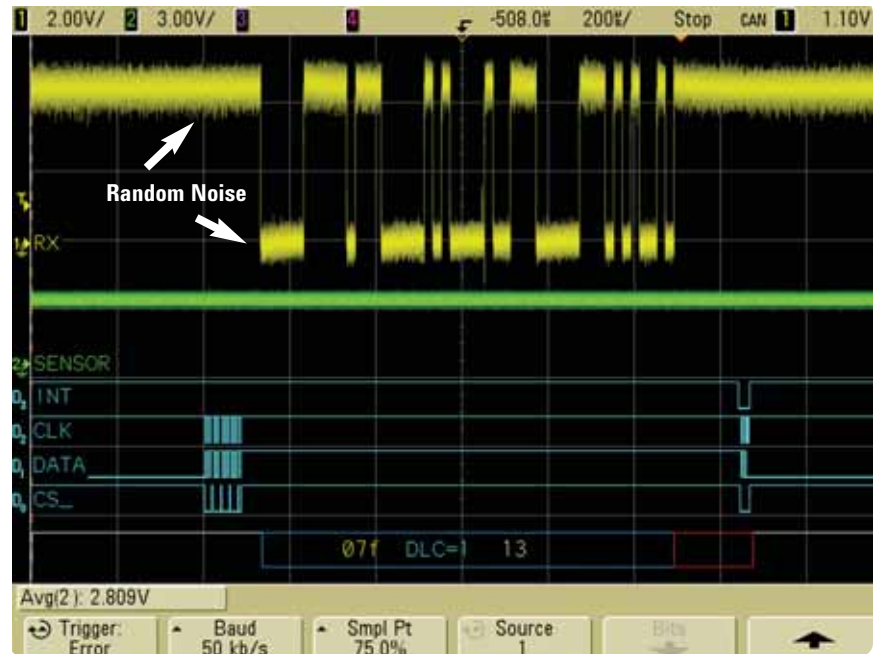

Figure 5: Triggering on CAN error frames isolates acquisitions on bad frame transmissions

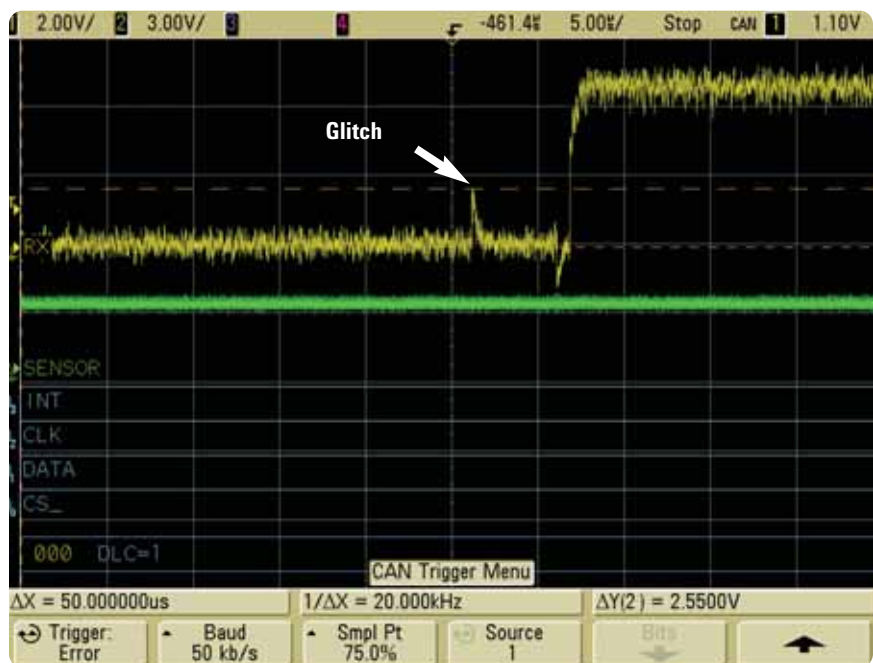

Figure 6: Zooming in on differential CAN waveform reveals a glitch

## Triggering the MSO on error frames reveals a signal-integrity problem (Cont'd)

After further inspection of the differential CAN signal on channel-1, the engineer discovered that a narrow glitch had occurred during this frame's data transmission just prior to the 5th rising edge of the differential CAN signal. When viewing this stored CAN frame in the normal "compressed" mode of a deep-memory acquisition (up to 8 M points) spread across the scope's display with the main timebase at 200  $\mu\text{s}/\text{div}$ , this narrow glitch was barely visible and could be easily missed, as shown in Figure 5. But when the engineer expanded the timebase on the stored trace to 5  $\mu\text{s}/\text{div}$  (Figure 6), the glitch was easily viewed with this scope's high sample rate resolution (up to 4 GSa/s).

After discovering this glitch and measuring its amplitude with the MSO's cursors, the engineer pressed the scope's front-panel RUN key again to begin repetitive acquisitions while triggering only on error frames. While observing the scope's repetitive waveform updates, the engineer could then see that narrow glitches were occurring not only infrequently, but also at random locations within the data frame and with no particular phase relationship to the differential CAN signal. It appeared that these glitches were being caused by signal coupling from a non-phase-related source. If the source of these glitches could be tracked down, then the root cause could more easily be determined and fixed.

## Triggering the MSO on the random glitch reveals the source of the problem

To synchronize the scope's display on the non-phase-related glitch rather than error frames, the automotive design engineer next set up the scope to uniquely trigger on the glitch. This was accomplished by using the scope's pulse-width triggering capability which can be defined to trigger on either positive or negative pulses based on a user-specified range of time (pulse-width). In this case, the engineer configured the scope to only trigger acquisitions on positive pulses of the channel-1 input (differential CAN signal) if the width of the pulse was < 500 ns. With this setup condition, the scope synchronized its display on the randomly occurring glitch, always capturing and showing the glitch near the scope's default center-screen trigger location. Now the CAN data frames appeared uncorrelated in terms of phase relationship relative to the glitch trigger source.

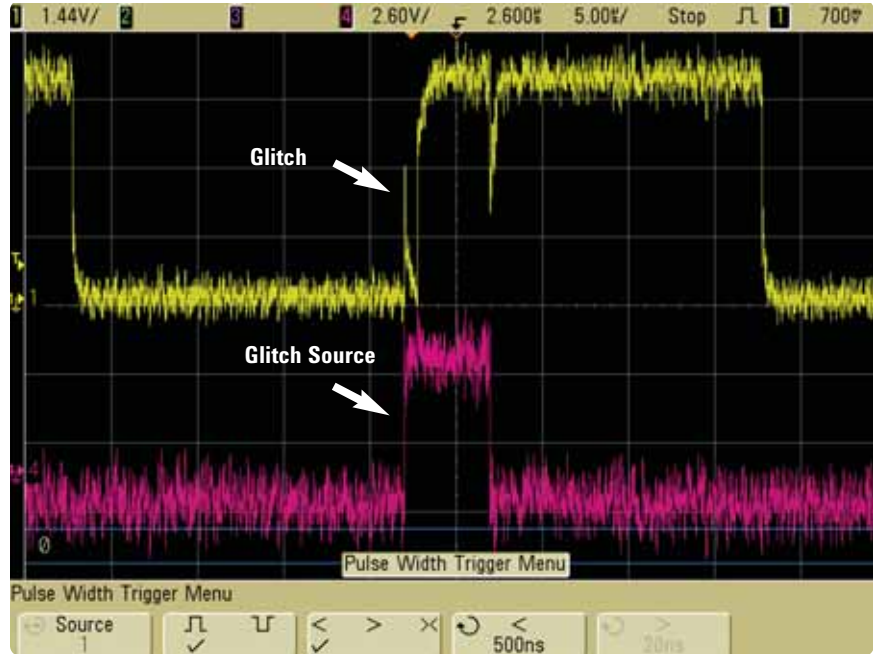

Figure 7: Pulse-width triggering reveals source of random and infrequent glitch

To track down the source of this glitch, the engineer then connected another probe to an unused channel (channel-4) of this 4+16-channel MSO and began probing “suspect” signals in the automobile to see which signal might be synchronized/phase-related to the glitch. After a few minutes, the engineer found the source of the glitch, as shown in Figure 7. The channel-4 waveform (bottom pink trace) shows a digital pulse that controlled a relay that triggered a high-voltage surge

within the vehicle's voltage regulator. If the voltage regulator cycled during the transmission time of data frame ID: 07F<sub>HEX</sub>, an error would occasionally occur in the windshield-wiper system. Once the engineer tracked down the source of the problem, it was fairly easy to isolate the windshield-wiper CAN node from the high-voltage surge signal with better shielding, which also significantly improved this CAN system's noise-immunity.



## Summary

This paper showed how an Agilent 6000 series mixed signal oscilloscope (MSO) can be used to more effectively and efficiently turn-on and debug an embedded mixed-signal design in an automobile that utilizes serial bus CAN data transmission. Critical characteristics of the MSO that enabled the automotive design engineer to quickly discover the cause of the intermittent problem included multiple channels of time-correlated analog and logic acquisition, fast waveform update rates, hardware-accelerated CAN bus decode, and various trigger-

ing capabilities including frame ID, error frame, and glitch/pulse-width triggering. Although this application note focused on an automatic windshield-wiper application, the debugging techniques described in this paper can also be directly applied to other automotive applications. The next time you need to turn-on and debug your embedded automotive mixed-signal design, you might consider using an Agilent 6000 series MSO in place of your current DSO, protocol analyzer, and/or logic analyzer measurement solution.

## Glossary

<b>ADC</b>	Analog-to-Digital Converter, sometimes referred to as an A-to-D
<b>CAN</b>	Controller Area Network is a differential 2-wire interface with data rates ranging from 10kbps to 1Mbps. Multiple applications include window & seat controls, engine management, and anti-skid systems.
<b>DSO</b>	Digital Storage Oscilloscope that acquires and displays analog characteristics of input signals using either real-time or equivalent-time sampling techniques
<b>ECU</b>	Electronic Control Unit is an embedded computer system found in automobiles
<b>I<sup>2</sup>C</b>	Inter-integrated Circuit bus is a common 2-wire serial bus that utilizes a self-arbitration protocol and is often used for chip-to-chip communication
<b>LIN</b>	Local Interconnect Network is a class A protocol operating up to 19.2kbps over a cable length up to 40 meters. Typical applications include window controls and other non-time/safety-sensitive functions such as comfort controls.
<b>MOST</b>	Media Oriented Systems Transport bus provides an optical solution for automotive media (entertainment) networks such as video, CD, etc.
<b>MegaZoom III technology</b>	An Agilent proprietary acquisition and display technology that provides a digital storage oscilloscope with extremely fast waveform update rates (> 100,000 real-time waveforms per second) and a high-resolution display quality that meets or exceeds the display quality of traditional analog oscilloscopes
<b>MSO</b>	Mixed Signal Oscilloscope that synergistically combines all of the measurement capabilities of an oscilloscope with some of the measurement capabilities of a logic analyzer and includes a time-correlated display of both analog and digital waveforms
<b>SPI</b>	The Serial Peripheral Interface bus is a 4-wire serial communications interface used by many microprocessor peripheral chips. The SPI circuit is a synchronous serial data link that provides support for a low/medium bandwidth (1 megabaud) network connection amongst CPUs and other devices supporting the SPI.

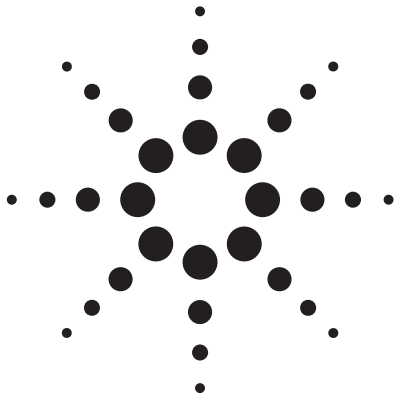

## Increase Automotive ECU Test Throughput

Application Note 1505

### Description

The automobile electrical system is poorly regulated and subject to frequent dips and overshoots. Voltage can range from 11 to 15 volts under normal conditions and from 8 to 24 volts under transient starting and running conditions. As a result, voltage margin testing is a necessary part of testing Engine Control Units (ECUs) to verify proper operation and tolerance for extreme bias voltage conditions.

### Problem

Every second of test time counts in the competitive automotive electronics marketplace. Testing at multiple bias voltage levels is a necessary, but time consuming part of ECU testing. Most system DC sources available require significant time to change and settle to a new output setting, adding several seconds to the overall test time.

### Solution

Agilent Technologies N6700 Modular Power System and N6752A power supply module incorporate features that reduce ECU test time and enhance testing, including:

- The N6752A 50 V, 10 A, 100 W autoranging power supply module features active down programming for fast output downward transitions regardless of load.

<b>DC Power Input</b>	<b>Communication Interface</b>
V <sub>Battery</sub>	CAN bus
<b>Static Analog Inputs</b>	<b>Static Digital Drive Outputs</b>
V <sub>Battery</sub> sense	Fuel pump
Engine temperature	Check engine light
Air temperature	A/C cutout relay
Manifold Absolute Pressure (MAP)	Fan relay
Mass air flow rate	EGR solenoid
Exhaust oxygen (Lambda)	Purge canister solenoid
Throttle position	Diagnostics code readout
<b>Dynamic Analog Inputs</b>	<b>Dynamic Digital Driver Outputs</b>
Engine knock	Fuel injectors
	Ignition coils
<b>Static Digital (or Switched) Inputs</b>	<b>Static Analog Outputs</b>
Ignition switch: off, acc., on, crank	Regulated voltages or currents for sensors
Acc. on/off; A/C, heater, brake, lights	
Throttle idle position	
Diagnostic mode	
<b>Dynamic Digital (or Pulsed) Inputs</b>	<b>Dynamic Analog Outputs</b>
Vehicle speed	Idle speed control servo
Camshaft/engine speed	
Camshaft/engine position	

Figure 1. ECU Inputs and Outputs

- Less than 1 millisecond command processing time reduces test time.
- Less than 4 milliseconds output response time reduces test time.
- Identical modules can be paralleled and operated as a virtual single output for greater output current and power, for testing higher power ECUs.

- Up to four modules fit in the 1-U high mainframe, saving test system space.

### ECU Input and Output Characteristics

An ECU takes a myriad of signals monitoring the vehicle and its environment. In turn it manages and controls the engine and ancillary equipment for optimum operation. Figure 1 summarizes the many input and output signals of a typical ECU.



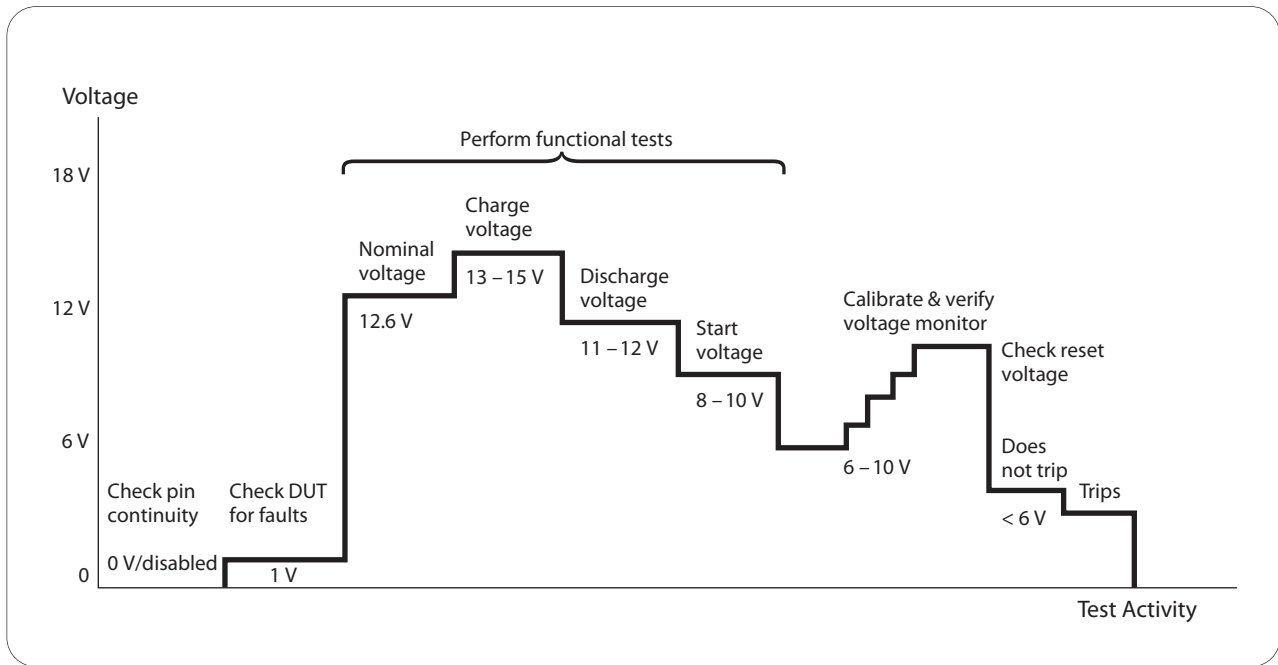

Figure 2. Key Bias Voltage Levels

In ECU functional test, appropriate test system resources emulate the various input signals in a controlled manner and load and check the outputs for correct response. It is readily apparent based on the number of inputs and outputs that test system resources for ECU test is quite extensive.

#### Key Bias Voltage Levels in Automotive Electrical Systems

Depending on the operating state of the vehicle, certain voltage levels are commonly encountered in an automotive electrical system. These levels become key voltages for ECU test, as illustrated in Figure 2. Some relevant tests at key voltages include:

- Continuity between multiple ground, power and high current driver pins is checked with the power supply set to zero or disabled.
- Shorts or other unexpected faults can be checked by applying a very low voltage and measuring the resultant current.

- Various functional tests are run from a low level of around 8 volts, representing starting, up to high level of around 15 volts, representing full charging conditions.
- The ECU voltage monitor circuit, if included, is calibrated or verified, typically by applying two end-point operating voltages at minimum.
- The ECU low voltage reset level is verified by checking its minimum “must not trip” and maximum “must trip” thresholds.

In all, an ECU may be subjected to up to 20 bias voltage level changes during test.

### Power Supply Output Response Time

A few steps occur when changing a power supply output voltage setting to a new value, as depicted in Figure 3. These steps all take a finite amount of time.

Once a command is received by the power supply-it must process it; this is its command processing time. The power supply's output then responds and changes to the new setting. The time it takes to reach its final value, within a certain settling band, is its output response time. A 1% settling band is suitable for ECU test.

Table 1 compares the command processing and output response times of many typical programmable power supplies to the N6700 and N6752A. The exceptional speed characteristics are a result of being designed for high throughput test applications.

It is especially important to take note of down programming output response time. Many power supplies depend

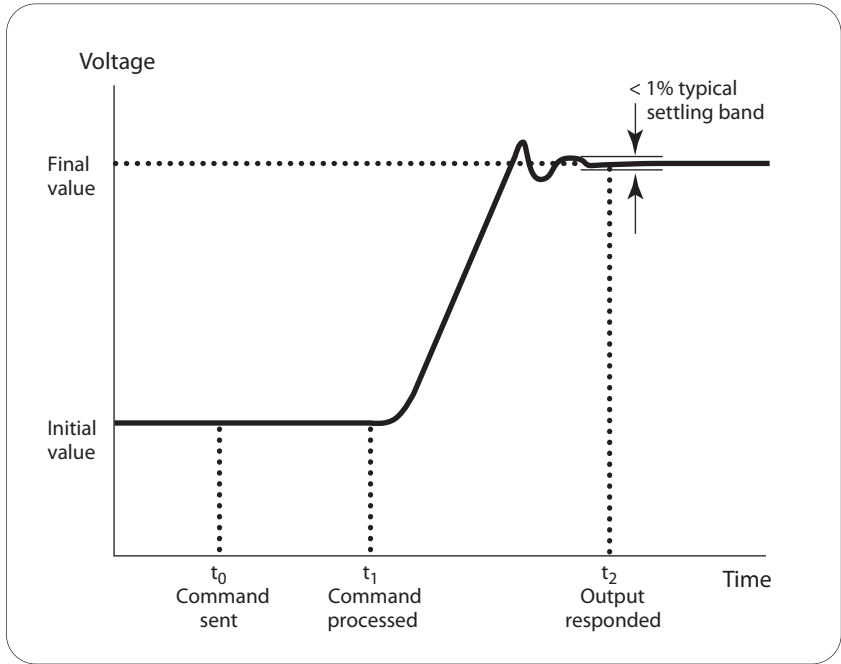

Figure 3. Power Supply Command Processing and Output Response

upon the actual loading of the DUT to bring the voltage down. Under light loading conditions it can take a second or more for some power supplies without down programmers to reach their final value. The N6752A power supply module incorporates an internal down programmer for fast down programming, independent of the load. Both fast up and down programming speed is important in ECU testing.

### Throughput Improvement Using Agilent Technologies N6700 Modular Power System and N6752A Power Supply Module

The test time reduction achieved by switching to the N6700 and N6752A from a slower power supply is a product of the command processing and output response time improvement and the number of output voltage transitions. A 200-millisecond time improvement and 15 output transitions yields a 3 second test time reduction. For an ECU having a 20 second test time, this translates to a 15% improvement in throughput. Such an improvement is highly valued by ECU manufacturers, greatly reducing their cost of test and providing immediate benefit.

### Related Applications

- Automotive Electronic Control Modules (ECMs)
- Automotive Body Electronics
- Automotive Telematics

Parameter	Agilent N6700A/N6752A	Typical System DC Sources
Command Processing Time	< 1 millisecond	20 to 50 milliseconds
Output Response Time	≤ 4 milliseconds to 50 mV	50 to 500 milliseconds to <1%

Table 1: Command Processing and Output Response Times





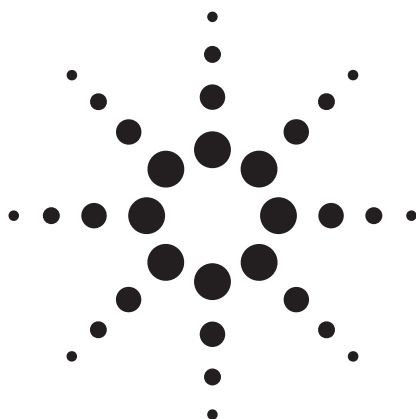

# Automotive Electronic Functional Test Using Agilent System Components

## Application Note

There are many types of electronic modules in automobiles today and new ones are springing up rapidly. In many cases, low frequency modules (i.e., ones without RF capabilities) can all be tested using a single system component architecture. This application note describes how best to use Agilent System Components to create a re-usable system tuned for low frequency automotive electronic functional test.

Of the many electronic modules found in cars, here are a few of the most common:

- Powertrain – engine control, transmission control
- Body – lights, chimes, door locks, windows, windshield wipers
- Anti-lock Brakes (ABS)
- Airbag

Table 1 lists some of the most important characteristics of these modules. Note that the number of pins that must be exercised during test is relatively small compared to data acquisition applications—fewer than 300. Power requirements are similar too. For ABS, Variable Reluctance Sensors or other isolated AC voltages must be generated. These signals are low frequency, just like the Cam/Crank/TDC/Knock signals required by engine/powertrain control modules. Body and ABS modules can require the driving of some high current loads, while Engine Control Modules need to handle high flyback voltages. Still, there are few if any RF signals needed, so there is no need for expensive RF test instruments.

Module	Number of pins	AC stimulus	DC stimulus	Voltages	Currents
Powertrain	100-300	4-8 waves	8-32 dacs	12-48 V	1-8 A
Body	50-150	2-4 waves	4-8 dacs	12-48 V	1-30 A
Airbag	5-80	0	2-4 dacs	12-48 V	2-8 A
ABS	25-50	4 waves	0-2 dacs	12-48 V	10-30 A

**Table 1.**  
*Comparison of characteristics of various automotive electronic modules*

These modules all have some similar characteristics that allow them to be tested using a single test system if it is architected properly. The subsystems that are required are:

1. Computing and I/O (LAN/USB/GPIB)
2. Serial Communication (e.g., CAN, LIN, ISO9141)
3. Low frequency Stimulus Instrumentation (D/A, Arbitrary Waveform)
4. Low frequency Measurement Instrumentation (DMM, Digitizer)
5. Load and Stimulus/Measurement switching
6. Device Under Test (DUT) DC Power
7. Mass Interconnect

Let's look at each of these in turn.



## Computing

Generally speaking, functional test systems require computers as the central controller. The most common choice today is the venerable PC running a Microsoft® O/S such as Windows® 2000 or XP, although it is certainly possible to use other types, including real-time controllers or Linux. The choice is a natural one because of the huge worldwide investment in the PC/Windows platform, which provides excellent price/performance. In some cases, when it is undesirable to have a PC on a production line for security reasons, equipment can be controlled by Programmable Logic Controllers (PLCs), which use ladder logic to achieve control, but this can be difficult to do since test instruments normally need to have ASCII commands sent to them over a bus such as LAN, USB or GPIB. An alternative to a PLC is an instrument that actually has a computer built-in, such as an Agilent Infiniium oscilloscope. Such an instrument can be used as the system controller. However, most test racks use either a standalone rack-mounted PC or an embedded PC in a cardcage such as VXI or PXI. Standalone PCs generally cost much less than the equivalent embedded PC and also have plenty of room for peripherals inside, so they are the more common choice. Agilent does not offer PC's, either embedded or standalone, but uses Advantech Industrial PCs ([www.advantech.com](http://www.advantech.com)) in many of its platform and custom test systems. Industrial PCs offer configuration stability (a given configuration stays constant longer than a commercial version) and a large number of I/O slots for expansion capability. They are also rack-mountable, in contrast to a desktop PC which is usually a challenge to mount in a rack.

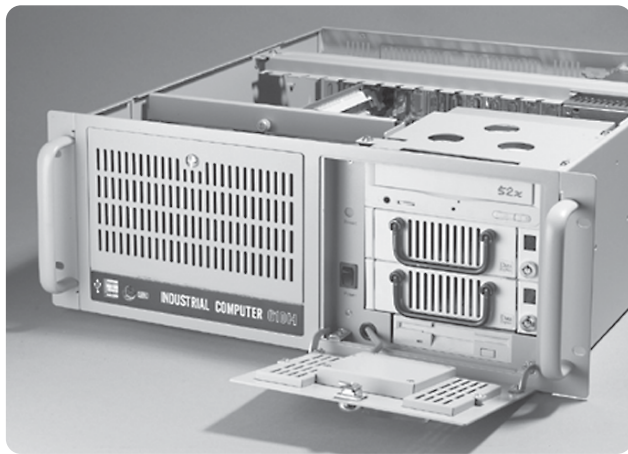

**Figure 1.**  
*Industrial Rack-Mountable PC*

As for I/O, all new instruments from Agilent are being released with LAN and USB interfaces. LAN provides an effective and inexpensive way to transfer data among the instruments. Agilent I/O libraries provide an easy and industry standard way to connect instruments to the PC through a hub, switch or router. Figure 2 (below) shows how LAN can be the backbone of your system, providing connectivity to virtually any instrument.

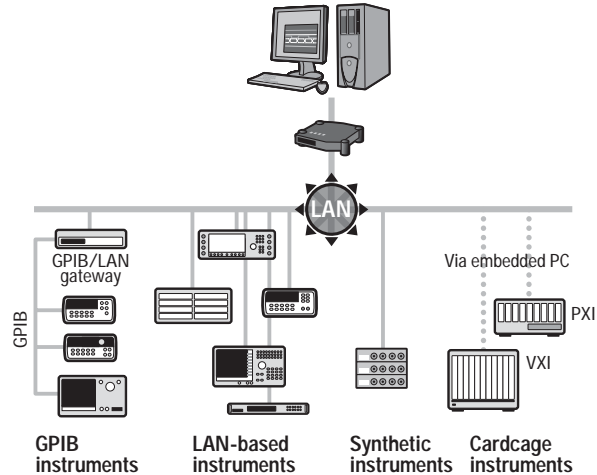

**Figure 2.**  
*LAN as the backbone of a test system*

## Serial communications

Modern electronic modules have serial busses interconnecting them. The protocols in common use are CAN, LIN, ISO9141 and J1850, but there are many more. These serial interfaces are used for several purposes:

1. In operation in the vehicle, they inform a central controller that they are alive and functioning, and can provide run time transfer of sensor information (wheel speed, temperature, etc.) to a host controller. Serial protocols are also used for field diagnostics such as service bay “on board diagnostics” (OBDII).
2. During manufacturing test, they can be used to activate built-in self-test (often called BIST or DUT-Assisted Test) routines that isolate one section of the module at a time so that the entire module does not have to be running in its operational mode in order to perform tests. This is a real time saver. Companies that do not provide BIST routines typically have test times that can take several minutes, compared to about 10-20 seconds for modules having BIST.
3. At final test, operational code can be downloaded into the modules.

Although Agilent does not currently offer serial communications products, many small companies do offer good solutions. One such company is Engenius, of Livonia, Michigan. The Engenius Multicomm III/s has been used in the Agilent TS-5400 Series II automotive functional test system for many years. There are also PCI plug-in cards and other standalone boxes available. For additional information see [www.EnGenius.com](http://www.EnGenius.com).

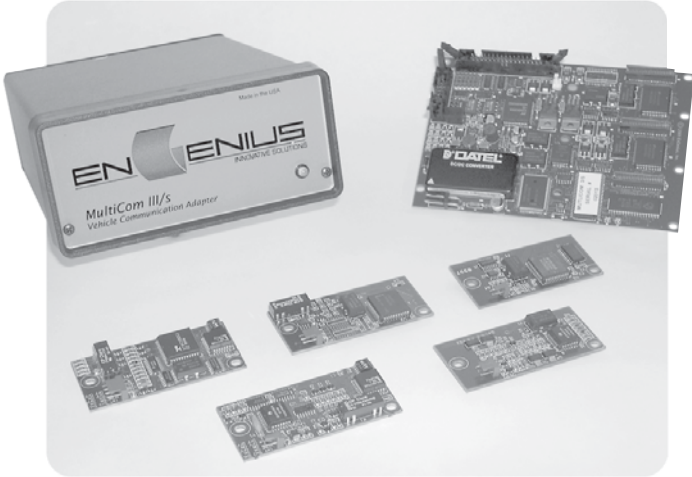

**Figure 3.**  
*Engenius Multicomm III/s (with box enclosure removed) with personality modules to handle various serial protocols*

### Low frequency stimulus instrumentation

In automotive electronics, it is often necessary to create many dynamic (AC) waveforms and many static (DC) voltages at the same time, even when using BIST routines. For example, in a powertrain electronic module, it is necessary to generate Cam, Crank and Top-Dead-Center signals which are phase locked, and a knock signal. Oxygen sensors, throttle position sensors and other sensors are often simulated with programmable DC voltages. Thus, several arbitrary waveform (Arb) channels and several D/A converter (DAC) channels are required. The 34980A can be used for these applications, thanks to its 34951A 4-channel isolated DAC card with downloadable sequence memory, allowing it to be used as both DACs and Arb.

An Agilent tutorial series on the web shows how to download Cam/Crank/TDC waveforms to the 34951A 4-channel DAC card. See [www.agilent.com/find/waveforms](http://www.agilent.com/find/waveforms).

### Low frequency measurement instrumentation

A 6.5-digit digital multimeter (DMM) is the most obvious measurement instrument needed by a test system. Not only is it good for taking fast DC and AC voltage, current and resistance measurements for testing the DUT, it also serves as a diagnostic tool to verify switch paths within the system. In most cases, a relatively inexpensive DMM such as the 34401A or the one that is built into the 34980A is sufficient. However, it is wise to not rule out the more expensive 8.5 digit 3458A if a digitizer is also needed. The 3458A can be used as a digitizer for measurements up to about 100K Sa/s. As a dual-purpose instrument (voltmeter and digitizer), it can save rack space and cost over the use of standalone digitizers or oscilloscopes.

Testing of engine control modules typically requires the measurement of inductive flyback from ignition coils (~450 volts) and fuel injectors (~80 volts). These are low energy voltage spikes, but the high voltages require some special care. Since 34980A relays can handle 300V with no problem, the 80 volt spikes from the fuel injectors are easily measured. However, ignition coil flybacks require attenuation before they can be measured. One good way to do this is to add an attenuator to a system using the 34980A breadboard card. A simple resistive divider can be used, or a more exotic solution can be obtained by putting a dual-range attenuator on the card that attenuates voltages above say, 14V, and leaves them alone under 14V. In this way, you can get full accuracy on saturation voltages while still being able to measure the high voltage flyback at somewhat reduced accuracy.

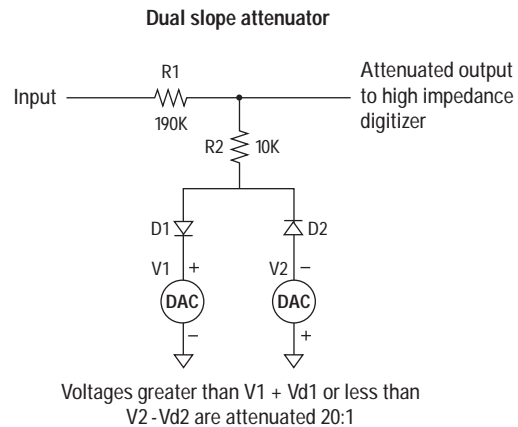
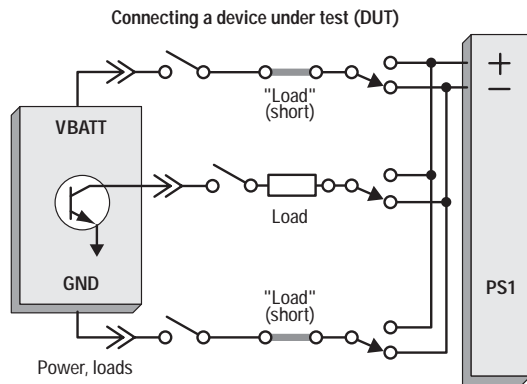

**Figure 4.**  
*Typical circuit for breadboard card to allow measurement of high voltage flyback pulses from fuel injectors and ignition coils. The DACs can be on-board voltage sources, or the 34951A card DACs can be routed to the Breadboard card.*

## Load and measurement switching

Another facet of automotive electronic functional test is the requirement to attach loads to the outputs in order to simulate the loads found in a real automobile. These can be light bulbs, solenoids, resistors, motors and even other electronic modules. This means that a physical space needs to be created in the test system for mounting of such loads. This can be done in a number of ways. Card cages that are large enough to hold relays and loads can be devised, as is done in the Agilent TS-5400 Series II test system's "switch/load unit" (SLU). The SLU is a VME enclosure with a special backplane, and interfaced to the PC via a parallel port. Special relay cards capable of handling the high load currents (2-30 Amps) were developed. In many cases, the required loads could be placed directly on these load cards. This box also served as a place for instrument switching. Alternatively, loads can be mounted on a slide-out load tray, with cables run to the switching system.

Today, with the Agilent 34980A switch/measure unit, much of the functionality previously done in the TS-5400's SLU can now be moved into a standard product. The 34980A can handle load currents up to 5A. Higher currents drawn by motors and light bulbs must still be handled externally, however the 34980A offers the capability of driving such external relays via the breadboard card. A number of latching and non-latching armature relay cards are available for the 34980A to handle load channels.



**Figure 5.**  
**Typical load switching in an automotive electronic test system. Loads can be physical parts such as light bulbs, resistors or motors as indicated by the box in the center, or they can be simple wires ("shorts") as shown at the top and bottom, which is a handy and consistent way to connect power supplies to the DUT. The SPDT relays on the right can be omitted if reverse polarity is not needed.**

It is necessary in any test system to apply static and dynamic voltages and currents to various pins on the device under test (DUT) and then measure the response on other pins, usually with a DMM and an oscilloscope or digitizer. In order to maximize the re-use potential of such instruments while keeping test system costs as low as possible, a matrix switching architecture is often used. A full  $m \times n$  matrix that would allow any point on the DUT to be connected to any system resource would be very large and expensive. However, if BIST routines can be used to select only certain sections of the module, an " $m$ "  $\times$  8  $\times$  " $n$ " matrix can be used, allowing 8 single-ended or 4 differential measurements to be made at once.

Measurement and stimulus relays usually do not need to be high current, and can thus be implemented with reed relays or FETs, providing high speed switching which helps to improve throughput, an important consideration in high volume manufacturing test. Load relays typically require armature relays, which are by nature slow (on the order of 10-20 ms to close and again to open). The 34980A provides all three types of relays in various configurations (general purpose, mux and matrix), providing maximum flexibility.

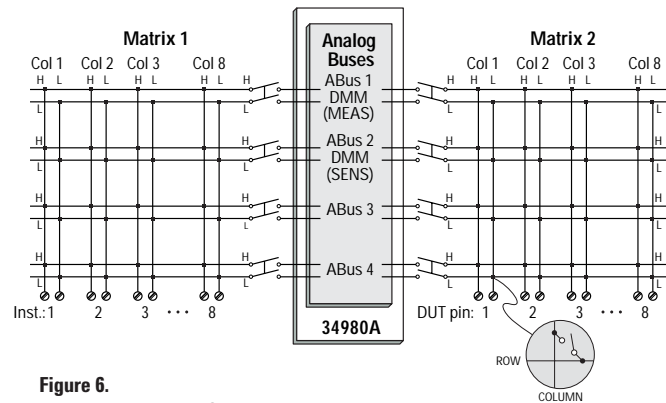

**Figure 6.**  
**" $m$ " instruments  $\times$  4 2-wire busses  $\times$  " $n$ " DUT pins**



## DUT power

In a functional test system, the DUT must receive DC power in order to operate. Often, this supply voltage must be stepped to a number of different levels in order to verify the electronic module's response to low or high battery conditions. In a test system, these steps need to execute quickly so that power supply settling time does not become a bottleneck. It is also sometimes desirable to provide a second supply dedicated to the loads. Other voltages are needed occasionally for line automation control. A good system component, then, must be a small, multi-output programmable supply that can respond to commands quickly and that has outputs that can change quickly. The N6700A power supply fills these requirements admirably.

Parameter	Agilent N6700A/N6752A	Typical system DC sources
Command Processing Time	< 1 ms	20 to 50 ms
Output Response Time	< 4 ms to 50 mV	50 to 500 ms to <1%



**Figure 7.**  
The N6700 is an excellent choice for a multi-output programmable DUT power supply

## Mass interconnect

Getting the system resources out to the DUT in a way that allows changeover from one DUT to another requires a mass interconnect scheme. This is best implemented using either Mac Panel or Virginia Panel standard connection schemes. Virginia Panel offers a set of pre-assembled cables that can be used to connect the 34980A to their terminal blocks. See [www.vpc.com/agilent/](http://www.vpc.com/agilent/) for details.

**Quick, Convenient Connections**  
VPC provides ready-to-use cable assemblies to connect between standard Agilent instruments and the VPC receiver. One end of the cable is connected to the Agilent instrument; the other is installed into the receiver to make a fast, efficient connection. Use them to mass interconnect your system and make the most out of your Agilent application.



**Cable Assemblies for Agilent 34980A Instruments**  
Download VPC Cable Solutions for Agilent 34980A Instruments

Agilent Card	20" RCVR Cable Assembly	36" RCVR Cable Assembly	Mating ITA Module	36" ITA Patchcord	Patchcord QTY
<b>Multiplexer Modules</b>					
34921A	540 111 040 140	540 111 040 240	510 151 105	720 109 101	102
34922A	540 112 020 140	540 112 020 240	510 151 105	720 109 101	158
34923A	540 111 040 140	540 111 040 240	510 151 105	720 109 101	102
34924A	540 112 020 140	540 112 020 240	510 151 105	720 109 101	158
34925A	540 111 040 140	540 111 040 240	510 151 105	720 109 101	102
<b>Matrix Modules</b>					
34931A	540 111 020 140	540 111 020 240	510 151 105	720 109 101	102
34932A	540 111 020 140	540 111 020 240	510 151 105	720 109 101	102
34933A	540 111 020 140	540 111 020 240	510 151 105	720 109 101	102
<b>General Purpose Modules</b>					
34937A	540 111 030 103	540 111 030 203	510 108 126	720 101 101	94
34938A	540 111 020 103	540 111 020 203	510 108 126	720 101 101	94
<b>RF &amp; Microwave Modules</b>					
34941A	540 129 010 109	540 129 010 209	510 108 132	710 102 137	20
34942A	540 128 010 132	540 128 010 232	510 108 179	710 106 434	20
34945A	540 010 020 101	540 010 020 201	510 108 101	720 101 101	10
34946A	540 130 010 107	540 130 010 207	510 108 111	710 102 137	6
34947A	540 131 010 107	540 131 010 207	510 108 111	710 102 137	9
<b>System Control Modules</b>					
34950A	540 116 020 140	540 116 020 240	510 151 105	720 109 101	158
34951A	540 019 020 101	540 019 020 201	510 108 101	720 101 101	51
34952A	540 019 020 101	540 019 020 201	510 108 101	720 101 101	51
<b>Mainframe (Analog Busses)</b>					
34980A	540 011 020 101	540 011 020 201	510 108 101	720 101 101	10

**Figure 8.**  
Virginia Panel web page<sup>1</sup>

<sup>1</sup>Used with permission, Virginia Panel Corp. All legal and privacy restrictions apply. See [http://www.vpc.com/privacy\\_statement.htm](http://www.vpc.com/privacy_statement.htm)

## Putting it all together

Figure 9 shows an example of a test system architecture that can be used for many automotive electronic modules. The matrix switch allows many measurement devices to be connected to the DUT via the 34980A's 4-wire differential bus. The armature switches are used for loads, and the isolated DAC cards are used for DC and AC stimulus. The N6700 power supply is used to provide DUT power. In this way, the 34980A forms the core of the system. An external PC would be used to control all devices using LAN. A 3rd party serial communications interface would be used to provide CAN or other serial communications to the DUT. All wires leading to the DUT would pass through a fixture interface such as a Mac or Virginia Panel (not shown for clarity).

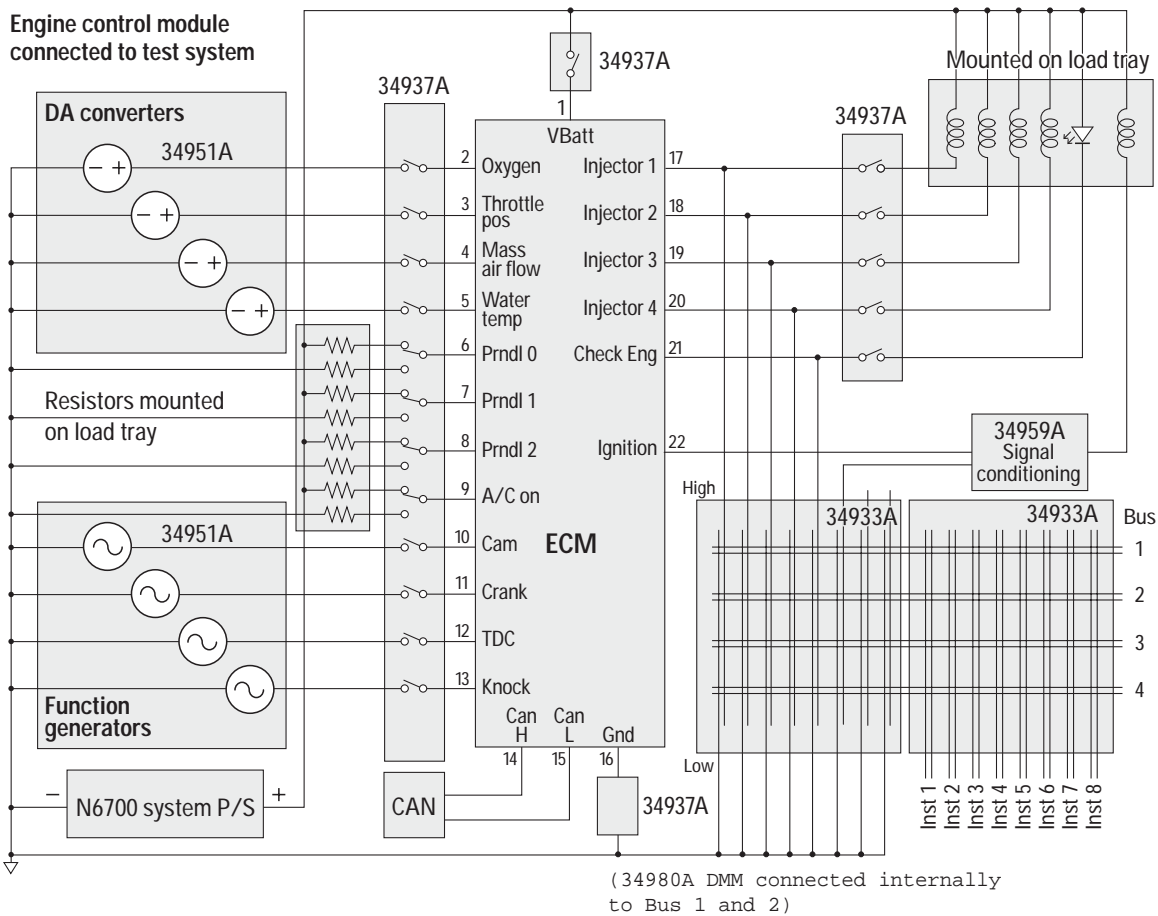

**Figure 9.**  
**Typical design of an automotive electronic functional test system.**  
**In this example, only one 4x8 bank of relays was shown on the 34933A matrix. Add more banks and more cards to be able to connect to more DUT pins or more instruments. "Inst1-8" can be external instruments or cards internal to the 34980A, such as the counter/timers.**



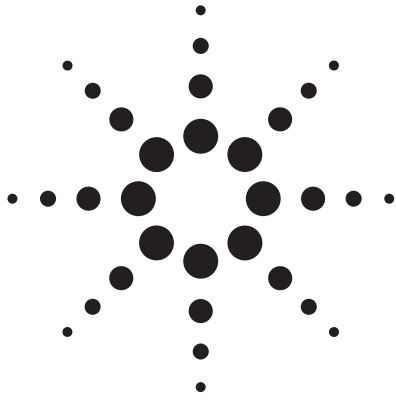

# Testing Antilock Brakes and Traction Control with the Agilent TS-5000 Family of Automotive Electronics Functional Test Systems

Application Note

## Agilent Technologies TS-5400 Series II Automotive Electronics Functional Test System

### Antilock brake system/traction control electronic control module testing

Smarter cars are here; they warm your seats, set your radio station, tell you where to turn next and drive over icy patches and wet roads. The latter of these features is of particular concern for most drivers weathering the changing seasons and terrain of their everyday driving route. Antilock brake and traction control systems (ABS/TC) are considered necessary car safety features today. As a result, ABS/TC electronic control module (ECM) manufacturers are pressured to make safer, more reliable systems. For this reason, functional testing of ABS/TC ECMs becomes paramount and extensive monitoring of the system components is done in its normal course of operation.

ABS/TC ECM functionality relies on variable reluctance sensors (VRS), solenoids, pump motors and fail lamp outputs, which all have "recapture" monitor lines that allow it to determine the state of each input/output. What follows is a sampling of manufacturing functional tests on the ABS/TC ECM that lend to increased reliability and system integrity using the Agilent Technologies TS-5400 Series II electronics functional test platform.

### Serial Link

The backbone of UUT-assisted testing (manipulation and verification of ECM functionality via the serial link) lies in the ability of the ECM to communicate with the test and measurement instrumentation. The common serial interfaces include UART-based ISO-9141, J1850 (pulse width modulated and variable pulse width), and J1939 (controller area network).

### I/O Check

An input/output check may be easily accomplished by verifying that the ECM correctly reads the states of a given input or output.

### Testing

*Typically, the ECM designer determines the algorithm for setting the module in either a TEST or RUN mode. This algorithm, a specific handshake for example, is often executed in a given window of time just after the system is powered up (.500 ms for example), which is determined by the serial interface chosen. Therefore, testing the serial communication of the ECM can be accomplished using one of several methodologies based on specific ECM design.*

### Agilent TS-5400 Series II testing solution

In an effort to meet the needs of the most common serial interfaces, this system features an optional serial port adapter that supports ISO-9141, J1850, and J1939 serial communication. In addition, the Test Executive software provided with the platform has built-in action sets to facilitate serial communication to set the ECM in either test or run mode. The software envelope supporting this hardware feature set includes easy-to-use commands for test plan development.

A few Agilent TestExec SL actions related to serial port communication follow. Aside from the expected Read/Write/Configure software capabilities for serial communication provided, the test executive streamlines common process steps used in ECM functional testing. For example, sending the ECM a periodic "keep alive" message (referred to as a group message below) to maintain TEST mode (rather than RUN mode) is made significantly easier with the following actions:

**mComConfigGroup:** Configures any of the support serial interfaces for a group message

**mComStartGroup:** Specifies the time between groups, between group elements, group repeat count and the group message itself. GroupRepeatCount = 0 represents indefinite repetition of a keep alive message



## Variable Reluctance Sensors

A variable reluctance sensor (VRS) at each wheel provides wheel speed signals to four receivers located in the ECM. Occasionally, the rear wheels share a sensor, but this is seen less frequently in the industry today. The frequency generated by these sensors is directly proportional to velocity. Voltage levels on each VRS may range from 50 mV<sub>pp</sub> (at 20 Hz) to 200 V<sub>pp</sub> (at 5000 Hz).

### Wheel slippage detection

Since the frequency generated by the signals is proportional to velocity, frequency changes relative to each of the sensors indicate that slippage on one or more of the wheels have occurred. It is paramount, therefore, that the test platform provides up to four independent, isolated frequency signals if all four wheels are to be simulated at once. Additionally, these signals need to sweep along different ramp profiles, which traditional frequency generators are incapable of doing.

### Testing

*Three of the wheel sensor inputs are routed to three wheel inputs and are held at constant amplitude and frequency representing constant velocity (1V<sub>pp</sub> at 1kHz for example). The fourth wheel sensor input is applied with a swept waveform in both an upward and downward ramp; see Figure 1. The test verifies that at a certain frequency difference between the wheels, or at a certain change in frequency for a given wheel, the correct isolation or purge solenoids are activated.*

### Agilent TS-5400 Series II testing solution

This system can be configured to include the E6173A arbitrary waveform generator for use in this test. Ramp times can be programmed with the E6173A ARB to be symmetric or asymmetric, depending on the desired input. Frequency generators cannot provide this type of complex swept waveform. The platform's software includes built-in actions allowing ease of programming for ramp up times, duration and ramp down times. The E6173A has two isolated channels. Therefore, if simulation of four simultaneous wheel speeds is desired, using two generators is advised.

Supporting this hardware solution is the test executive software envelope with action routines and test plan examples for the E6173A arbitrary waveform generator.

A sampling of TestExec SL actions for the E6173A ARB include the following:

**arbConfOut:** Configures the ARB's output circuitry

**arbSet:** Programs the ARB by transferring all settings specified in the configuration

**Arb\_DI\_Swept\_:** Downloads a basic swept waveform of specified frequency, amplitude and offset

**Arb\_DI\_Std\_Waveform:** Downloads a sine, square/ pulse, or triangle waveform of a specified frequency, amplitude, and offset.

**Arb\_DI\_Custom\_Waveform:** Downloads a custom, user-defined waveform consisting of up to ten sequences with fifty segments per sequence to the ARB.

### Cross Talk

Testing the ABS/TC module's handling of cross talk is important when assessing the system's ability to properly interpret the incoming VRS wheel signals. Misinterpretation due to channel-to-channel cross talk may cause the system to react incorrectly.

### Testing

*One channel is set to high voltage AC and the others are set to either low-level AC values (less than 100 mV) or to DC. If cross talk due to the high-input voltage channel exists, the low-level channels will respond, despite the fact that their own voltage levels do not warrant action. Speed status is requested via the serial link and no speed should be present on the non-driven inputs.*

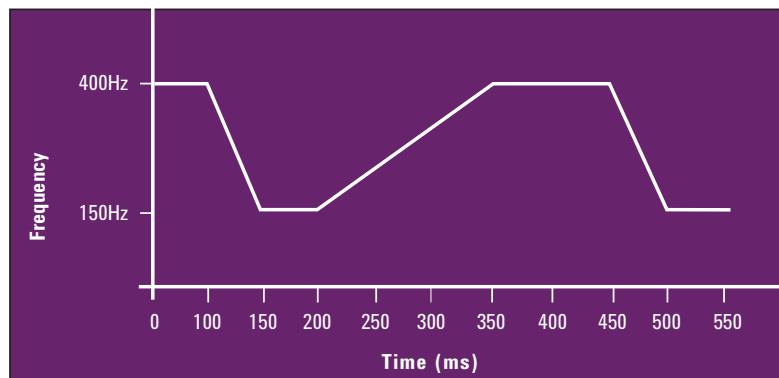

Figure 1: Swept waveform for fourth wheel sensor input (other three held constant)

## Wheel Speed Threshold

The required response of the VRS receiver located at the ECM is illustrated in Figure 2. Verifying this expected behavior requires testing at multiple frequencies to characterize the wheel speed threshold.

### Testing

*This test would require the ability to apply various discrete input voltage and frequency values. The test might include input frequencies of 18 Hz, 400 Hz, and 1800 Hz at voltage levels just above and below the threshold at each frequency.*

### Agilent TS-5400 Series II testing solution

To perform the cross talk test, the E6173A Arbitrary Waveform Generator will generate up to 32 V<sub>pp</sub>, requiring a step-up transformer in order to generate the required testing voltage levels. The optional E6171B Measurement Control Module (MCM) has an on-board transformer that can deliver 160 V<sub>pp</sub>.

When testing the wheel speed threshold, the generated waveform does not require additional signal processing since the stimulus is no more than 2 to 3 volts for high-frequency testing. In both tests, the system supports common serial communication, including ISO-9141, J1850, and CAN/J1939 for response verification from the ECM.

### Short/open sensor

In the vehicle, the ECM monitors shorts and opens on the VRS sensors. A VRS sensor includes a ferromagnetic disk and sensing coil. This sensor may be represented in an overall circuit as a 1.5kΩ resistor in series with an AC voltage source. The ECM passes current through the sensor, which should be floating with respect to chassis for noise rejection. Therefore, monitoring the sensors for shorts or opens becomes crucial to maintaining system integrity. The sensors may be compromised, for example, when salt deposits cause leakage current to pass from the sensor to chassis ground. This results in decreased noise rejection, which leads to improper event determination by the ECM. Similarly, if the sensor were opened, current would not pass and event determination would once again be inaccurate.

### Testing

*In the vehicle, the ECM monitors the shorts and opens. In production testing, the VRS open, short, and short-to-chassis detection feature is accomplished via relay-induced faults. The fault is verified by interrogating the ECM via the serial link and/or by the ECM turning on the display failure lamp.*

### Agilent TS-5400 Series II testing solution

This test system can be configured to include several different load cards for this application. In particular, E6175A 8-Channel Load Card, E6176A 16-Channel Load Card, and the E6177A 24-Channel Load Card would be appropriate choices. Since VRS testing involves current levels no greater than a few milliamps, users typically select the E6177A 24-Channel Load Card due to its bridge load capabilities. Serial communication with the ECM may be accomplished via one of the common interfaces supported by the platform: ISO-9141, J1850, or J1939.

The test executive software supports the comprehensive signal and load routing architecture. The TestExec SL switch path editor provides a less cryptic, easily read path description. In addition, for test plans where relay actions are repeated in various sections, relay state tracking streamlines redundant commands by recognizing the existing state of the relay, thereby speeding the time of test.

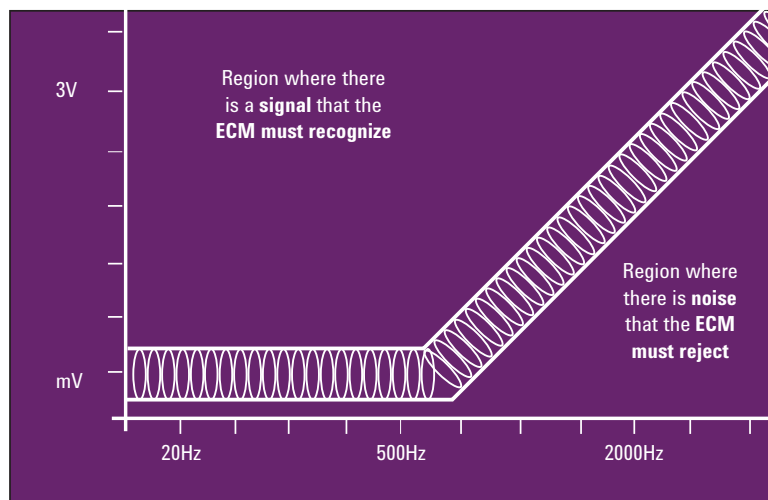

Figure 2: ABS/TC ECM response to VRS input

## Solenoid Drivers

In order to control the wheel from slipping during an ABS event, braking pressure is modulated by the control of solenoid drivers (see Figure 3). ABS/TC response abilities ultimately rest with the ECM's ability to control the state of the solenoid-driven valves. Typical measurements of interest include the saturation and flyback voltage, driver leakage current and the ECM microcontroller ADC input recapture accuracy.

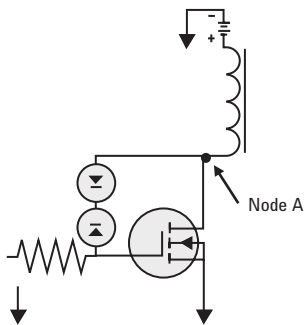

Figure 3: Typical lowside solenoid driver

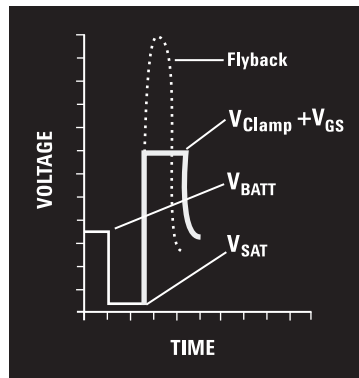

Figure 4: Voltage profile of solenoid deactivation

### Saturation voltage

Saturation voltage (see Figure 4) is important for characterizing the health of the solenoid driver electronics. Typical saturation voltage values range from 0.5–1V.

### Testing

*Saturation voltage, as seen in Figure 4, is measured at the solenoid output (node A in Figure 3) just after turning on the solenoid driver. This voltage is easily measured with a DMM or by using a digitizer (ADC) and maybe followed by serial interrogation of the ECM to determine the voltage it measured.*

### Agilent TS-5400 Series II testing solution

This system includes a digital multimeter and/or a digitizer. In addition, the E6175A 8-channel load card, E6176A 16-channel load card, and the E6178B 8-channel 30A load card can handle transient voltages up to 500V while protecting the output relays. Common serial communication interfaces supported by this platform include ISO-9141, J1850, and J1939.

Multiple measurements, including saturation voltage, are greatly facilitated through use of TestExec SL software actions including:

**ADC\_Config\_1\_Chan:** Configures E1563A or E1564A Digitizer for capturing a waveform for later analysis on Channel 1.

**ADC\_Analyze\_Wave:** Measures a waveform using the E1563A or E1564A Digitizer to analyze it for Vmin, Vmax, high pulsewidth, low pulsewidth, and period values. Measures Vmax and Vmin at the "offset" parameter's sample count after edges.

**ADC\_Min\_Max\_:** Returns Vmin or Vmax DC voltage values from the E1563A or E1564A Digitizer in a window defined by the "start" and "stop" parameter times from the trigger point.

### Flyback voltage

The inductive nature of the solenoids causes considerable voltage flyback when the solenoid is turned off (see Figure 4). If left unclamped, the flyback voltage can reach levels as high as 200 to 300 V, which must be limited to protect the solenoid driver. Typical clamp voltages are in the 40 to 60 V range.

### Testing

There are two readily recognized ways to test flyback voltage: a static measurement that uses a voltage source and resistor (see Figure 5) and a dynamic measurement with the solenoid load in place. The dynamic test is often considered a more credible method of test. In the case of the static measurement, a voltage source of  $\sim 100\text{ V}$  and a resistor of  $\sim 10\text{ k}\Omega$  may be used. The voltage is applied and the output,  $V_{out}$ , is measured to verify that the protective clamping circuit on the solenoid driver is functioning correctly (see Figure 5).

In dynamic testing, an Analog to digital converter (ADC) may be used to process the signal for use by the ECM microcontroller. The benefit of dynamic testing lies in its ability to capture multiple characteristics of solenoid driver behavior in a single test, such as saturation and flyback voltage. Typically, capturing the saturation and flyback voltage simultaneously is difficult because the first is 0.5 to 1V, while the latter may be several hundred volts. The disparity in these voltage levels prohibits good resolution of their values. However, by employing a dual slope attenuator, high voltages are attenuated within a range that captures both (saturation and flyback) to be captured with good resolution. Figure 6 illustrates a typical voltage profile resulting from a dual slope attenuator.

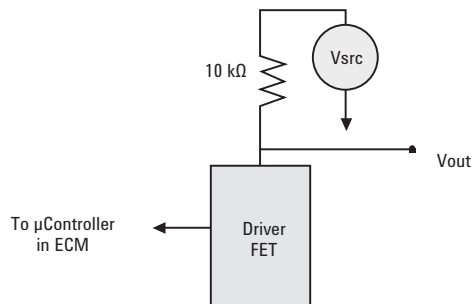

Figure 5: Static measurement of flyback voltage

### Agilent TS-5400 Series II testing solution

For static testing of the flyback voltage, the platform's E6171B measurement control module (MCM) can be programmed to apply a 100 V-compliance voltage with a current source limit of 1 mA. The output is then measured with a DMM to verify clamping levels of 40 to 60V. The TestExec SL software support for these actions include the following:

**ForceVMeas1:** MCM used as voltage source then measures the current flow using the DMM

In addition, the following parameters will define the test and qualify its results:

**Vapply:** Applied DC voltage  
**Iexpect:** Expected current (milliamps)  
**Iactual:** Actual current (milliamps)  
read by the DMM

For dynamic testing of flyback voltage, the system may be configured to include a digitizer (ADC) to simplify the test. Once the solenoid driver is turned on and off, the resulting output voltage waveform is captured and saved to a waveform data type file using built-in software actions. The MCM's onboard, programmable dual slope attenuator can be set to scale high input voltage values as desired.

Next, a comprehensive list of information may be extracted from the waveform, including flyback and saturation voltage, solenoid driver on/off time and duration of the flyback pulse. Using this platform with the optional digitizer allows this extensive data set to be acquired in just one setup.

Software support for this sophisticated test methodology includes the following TestExec SL action:

**ADC\_Transform:** Transform E1563A or E1564A digitizer returned data with the MCM attenuator gain and offset terms.

This action converts digitizer readings through the attenuator to the values at the input of the attenuator.

Parameters to define the test action and qualify the results are as follows:

**trigfirst:** 1=Reads data from digitizer before running analysis routines  
**atten:** Configures the attenuator; 1 = adjust for MCM attenuator, 0 = do not adjust  
**store:** 1 = Write to file, 0 = Do not write to file

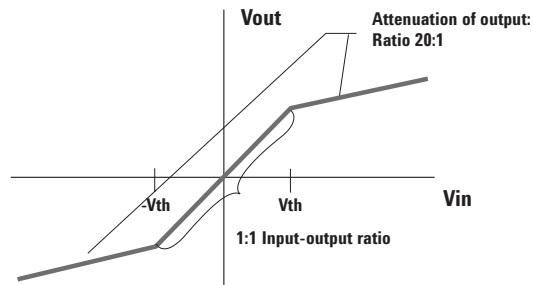

Figure 6: Input-output voltage profile of dual-slope attenuator

### Driver leakage current

Information on the driver leakage current verifies the health of the driver FET (see Figure 3). Excessive leakage current is indicative of possible electrostatic damage (ESD).

#### Testing

To measure driver leakage current, disconnect the load and measure the current flowing to the solenoid driver while it is in the "off" state at node A in Figure 3.

### ECM microcontroller ( $\mu$ C) ADC recapture accuracy

When the solenoid driver initiates, the  $\mu$ C ADC input must accurately capture the "on" voltage level and likewise, when the driver turns off, it must accurately capture the resting voltage level to determine the condition of the driver and solenoid load. Ultimately, in order for the ABS/TC ECM to behave appropriately and run its own self-diagnostics of the output solenoid, the  $\mu$ C ADC recapture must be accurate. For example, during operation of the vehicle, a test pulse is continuously generated every few milliseconds with a short duration of  $\sim 300 \mu\text{s}$  such that the driver is not activated (see Figure 7).

#### Testing

Disconnect the solenoid load and apply a DC voltage supply to turn on the driver. Determine the voltage value seen by the  $\mu$ C ADC recapture path by serial interrogation of the ECM. The voltage seen at the input to the  $\mu$ C should reflect the applied voltage giving consideration to the circuit design of the recapture path.

### Agilent TS-5400 Series II testing solution

The platform's MCM contains a VI function that applies a low fixed voltage and measures the resulting current. This functionality greatly simplifies the solenoid driver's leakage current measurement.

The TestExec SL software support for this action includes the following:

**ForceVMeasI:** MCM used as voltage source then measures the current flow using the DMM

For testing the  $\mu$ C ADC recapture accuracy, the MCM can be used as a dc source voltage to the solenoid driver. Through serial interrogation, several sections of the resulting voltage profile may be tested for accuracy. Generally, the "on" voltage of a few hundred millivolts, the resting voltage of  $V_{\text{batt}}$  and one other voltage level are used for verification. Serial communication with the ECM may be tested on any of the supported common interfaces: ISO-9141, J1850, or J1939.

## Smart Drivers

Today, ABS/TC systems often employ smart drivers that sense the condition of the solenoid and turn themselves off if the situation warrants, such as a short on the solenoid load.

#### Testing

Verifying that the smart driver responds appropriately to a short detection may require analog to digital conversion. Two facts should be verified: (1) the  $\mu$ C registers an over current condition when the solenoid load is shorted; (2) the smart driver reacted appropriately by shutting down to prevent damage. Verifying these facts requires knowledge of the peak and duration of the solenoid current profile, as seen in Figure 8. Finally, interrogation via the serial link will determine if the ECM was informed of an over current condition.

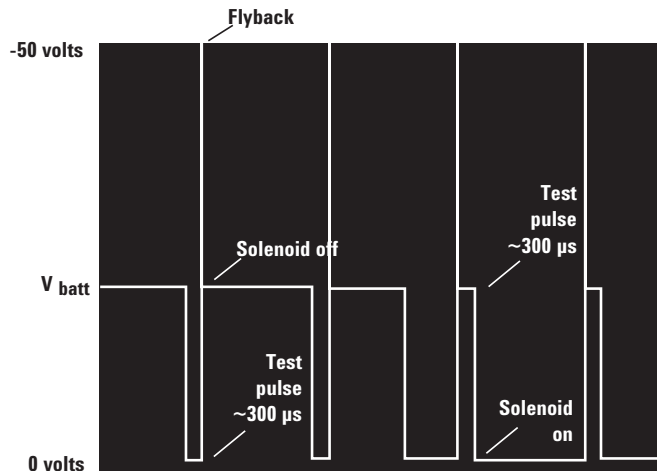

Figure 7: Test pulses applied regularly as a diagnostic input for determining ABS system integrity

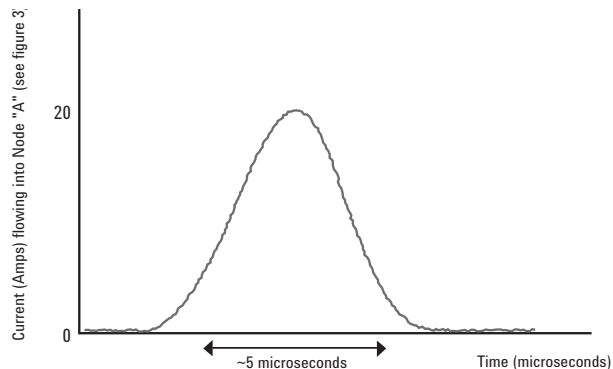

Figure 8: Solenoid current profile with working smart driver when load is shorted



### **Agilent TS-5400 Series II testing solution**

Using TestExec SL, this waveform may be saved with the needed characteristics, such as peak and duration of the solenoid current extracted from the results. In addition, if the driver fails to shut down, protective fuses are built-in to several of the load cards.

Relay induced faults, such as a short across the solenoid load, can be created with the available load card switching for this platform. Load cards featuring 50 mΩ-sense resistors for current sensing should be placed in series with the shorted solenoid load. Then, the voltage drop across the resistor can be measured by use of a digitizer or digital multimeter (also configurable with the platform). The results will determine if the driver shut down when the over current condition was induced.

The E6178B 8-channel heavy duty load card is typically selected for its high current capabilities. Other load cards are generally equipped with fuses to protect the card in the event of prolonged, high current applications. This test could potentially result in a prolonged high current scenario if the smart driver fails.

Serial interrogation via any one of the supported interfaces, including ISO-9141, J1850, and J1939, will verify that the ECM was prompted with an over current condition.

### **Pump Motor Driver**

Since hydraulic fluid is diverted to the dump accumulator during an ABS event, the fluid must be returned to the master cylinder/high pressure side of the hydraulic system. After each DUMP cycle, the pump motor is used to recycle hydraulic fluid to the high side of the ISO valve. The pump motor requires significant current with start-up surge currents as high as 200 Amps (for ~20 ms) and steady state currents of 10 to 30 Amps.

#### **Testing**

*Testing the pump motor drivers closely resembles the previously outlined algorithms for testing solenoid drivers. The distinguishing characteristic of pump motor driver testing is the potentially high current levels the test and measurement instrumentation must tolerate.*

### **Agilent TS-5400 Series II testing solution**

The load card switching capability of the E6178B 8-channel heavy-duty load card option with this platform has the current ratings to effectively test the pump motor driver despite the increased current levels. In addition, the loads are protected with 30 A fuses in the event that the pump motor driver fails to shut down.

### **Antilock Brake System Test Solution**

#### **Optional throughput multiplier**

The Agilent TS-5400 Series II automotive electronics functional test system may be configured to include an optional throughput multiplier, which is often used when testing low pin-count/complexity ECMs. The throughput multiplier facilitates multiple up UUT (unit under test) testing. Multiple up UUT testing results in decreased set up time of the instrumentation per UUT, consolidating delays in relay closures and overlapping time delays due to inherent UUT latencies. The TestExec SL software tool provides comprehensive support for this test strategy.

#### **Automotive electronics manufacturing environment**

The TS-5400 family of automotive electronics functional test systems offers support for factory automation. From a more basic automation scheme to the use of PLC (programmable logic controllers), the TS-5400 Series II has comprehensive serial communication support and digital I/O capabilities allow the platform to be integrated as part of an existing manufacturing environment.

#### **Overall solution**

The test needs for antilock brake system ECMs as generally outlined in this application note may be satisfied by the following instrumentation.\*

- Arbitrary waveform generator
- Digitizer
- Digital multimeter
- Serial port adapter
- Power supply
- Measurement control module
- Select load cards

\*Note: This instrumentation list is presented as a general test solution profile, and is not for use as a direct ordering guide. For information on the detailed platform profile, please refer to the Product Note.

#### **References**

Jurgen, Ronald. *Automotive Electronics Handbook*. McGraw Hill Inc, 1999.  
Mizutani, Shuji. *Car Electronics*. Sankaido Co, Ltd., 1992.





# Testing Remote Keyless Entry Systems with the Agilent TS-5000 Family of Automotive Electronics Functional Test Systems

Application Note

## Agilent Technologies TS-5400 Series II and TS-5020 Automotive Electronics Functional Test Systems

### Security and safety: testing remote keyless entry and immobilizer functionality

Security and safety go hand-in-hand in the world of automotive technology. Whether you are testing remote keyless entry (RKE) or immobilizers that provide protection from vehicle theft, the Agilent TS-5400 Series II and TS-5020 automotive electronics functional test systems are prepared with test solutions.

As the need continues to increase for luxury technology, automotive RKE systems are equipped with everything from door or trunk release to more sophisticated functions including starting the engine, setting a radio station, positioning seats, and adjusting mirrors. In addition, many RKE

systems are equipped with other features that include interior light activation, system disarmament, or automatic panic alert.

Typically, RKE functionality is embedded in the body control module (BCM) that controls electromechanical drivers for door locks, windshield wipers, interior lighting, and other such functionality. Developing a dedicated electronic control module (ECM) for RKE functionality is also an option. Figure 1 illustrates the components of a generic BCM with RKE functionality. In addition, the advent of RKE works in conjunction with the need for increased security in cars and the emergence of immobilizers.

What follows is a sampling of manufacturing functional tests that lead to increased reliability, security, and system integrity using the TS-5400 Series II and TS-5020 test systems for RKE and immobilizers.

The electronics behind RKE functionality lies in translating coded input from a key fob into commands for electromechanical drivers located throughout various parts of the car. In general, activity (as seen in Figure 2) includes code generation by a hand-held key fob, signal detection and processing, followed by authentication code verification. Finally, the electronic control module generates a serial command or direct output to a variety of drivers (door locks, seat positioning motor and more.)

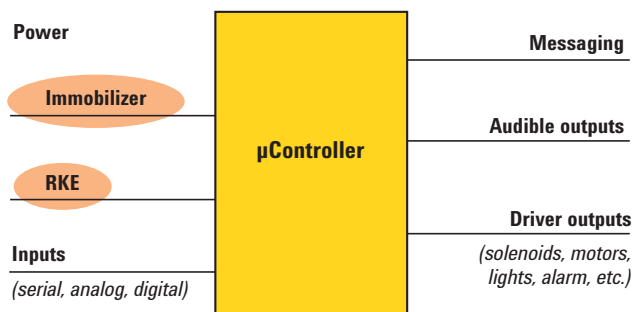

Figure 1: Body control module (with remote keyless entry & immobilizer)

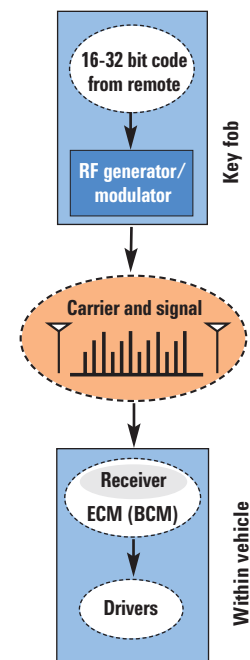

Figure 2: RKE functionality action flow



## Transmitter

In Figure 2, the key remote (transmitter) includes an identification signal generating integrated circuit and is powered by a small battery. The identification signal is typically a 32 to 64 bit rolling code, which requires some form of modulation in subsequent signal processing. Issues of security and sensitivity regarding the algorithm for generating this code render it a customer proprietary test section, often requiring treatment as a "black box." In this case, the customer generally supplies the code for the transmitter in the form of a working key fob or modulation device. Since RKE transmitters are inactive virtually 99% of the time, low power modes are important. In its inactive mode an RKE transmitter current of 100 nA is generally accepted with a current draw of 10 to 12 mA for active RF transmissions.

### Testing

*Though not always performed, testing the RF power output of the key fob may be of interest.*

*Testing may involve checking the signal strength of the key fob output amplitude and center frequency when it enters a particular mode. For example, following a certain keypad command the key fob may enter a continuous wave mode that generates a non-modulated RF output. Other test modes may include generation of an AM or FM output. When testing, a known working key fob maybe used to calibrate the tester, while subsequent testing is completed based on relative signal strength analysis. In conducting these tests, specific spectrum analyzers may be selected from the market.*

## Agilent TS-5400 Series II and TS-5020 testing solutions

Any of the Agilent ESA Series RF spectrum analyzers will meet the specifications needed for key fob power analysis. The test executive (TxSL) has several post-process data extraction, analysis and display capabilities for output amplitude and center frequency determination. The select data may be extracted and presented in a variety of formats including database entries, waveforms, arrays, etc., with associated units for easy-to-read reporting.

### Testing

*The transmitter is powered by a lithium coin cell battery. Typically, the battery life is expected to be > 5 years at 25 °C. To promote the lifetime of the battery, verification of leakage current during active RF transmission may be required.*

## Agilent TS-5400 Series II and TS-5020 testing solutions

These test systems may be configured to include a measurement control module (MCM). A built-in feature of the MCM includes the ability to provide a voltage or current source and measure the output current or voltage, respectively. Therefore, using the MCM as a voltage source, the output leakage current from the transmitter may be obtained.

## RF Generator

The RF generator modulates the carrier code creating an output for the RKE receiver. RKE RF bands are typically 315MHz in the United States and Japan or 434/868 MHz in Europe. Many current systems employ amplitude shift key modulation (ASK) as ASK-modulated data is easily created with surface acoustic wave (SAW) transmitters. However, frequency shift key (FSK) modulation is developing a wider following as a result of stable and accurate frequency shifting at higher data rates. Specifications for the generator are determined by customer need and may be selected from a variety of products in the market.

## Receiver and Drivers

An antenna with low voltage and current ratings receives input from the RF modulator. The receiver should operate on a 9 to 16 V car battery. The receiver detects a valid transmission (message authentication code or MAC) from the key fob transmitter, which includes the transmitter ID, rolling count, command code and status flags. To validate the MAC, the receiver compares its rolling count with the transmitter ID rolling count. The transmitter ID rolling count is stored in the receiver's non-volatile memory. For validity, the transmitted rolling count should be greater than or equal to the receiver stored count within a given count "window." If the rolling counts do not match within this window, the receiver may initiate a resynchronization. If the rolling counts match, the ECM generates a serial command to the drivers controlling door locks, interior lights, alarms and more.

## Testing

*As a general practice, there are two ways of verifying RKE functionality. Since RKE ECM test developers are not privy to the details of the rolling code, one way is to verify the serial command generation by the ECM and the second is by observation of the electromechanical driver response to a given input command. Each component of RKE functionality (seat positioning, interior lighting, panic alert, trunk release, etc.) may be tested this way by sending a transmitter command and verifying action via the serial link or through the relevant driver response.*

### Agilent TS-5400 Series II and TS-5020 testing solutions

These test systems can be configured to include a custom card for mounting the key fob/black box provided by the customer directly on the tester. The RF signal source is typically chosen between the N5182A and the E4438C signal generators for their bandwidth and modulation capabilities. Serial communication supported by the platform includes common interfaces such as ISO-9141, J1850 and CAN/J1939. Agilent TestExec SL includes support for easy integration of message-based instrumentation. By following the well documented instrument integration procedure in TestExec SL, a user familiar with the message-based instrument and its desired parameters can establish integration and comprehensive action definitions in under thirty minutes.

A few TestExec SL actions related to serial port communication follow. Aside from the expected Read/Write/Configure software capabilities for serial communication provided, the test executive streamlines common process steps used in ECM functional testing. For example, sending the ECM a periodic "keep alive" message (referred to as a group message below) to maintain TEST mode (rather than RUN mode) is made significantly easier with the following actions:

**mComConfigGroup:** Configures any of the support serial interfaces for a group message.

**mComStartGroup:** Specifies the time between groups, between group elements, group repeat count and the group message itself. GroupRepeatCount = 0 represents indefinite repetition of a keep alive message.

## Response Time

To gain appeal as a luxury commodity, the consumer-based success of RKE technology lies in the system's ability to respond quickly to the user's press of the keypad.

## Testing

*Normally, the elapsed time between pressing the RKE keypad and message generation should be < 300 ms. Therefore, determining the time to transmit, verify the code and generate a message is of utmost importance, and is measured in addition to the total time (including driver execution) of the system function (< 1 s).*

### Agilent TS-5400 Series II and TS-5020 testing solutions

A counter, such as the Agilent E1333A 3-Channel Universal Counter, may be used to measure the time difference between pressing the key fob and the resulting action (either code verification or total time). Supporting this hardware solution is the test executive software envelope with action routines for the E1333A Counter.

A sampling of the Agilent TestExec SL actions for the E1333A Counter include the following:

**ctrConfTrigIn:** Sets the input trigger.

**trigfirst:** Parameter used for trigger usage before reading. 0 for no, 1 for yes.

**ctrlsSet:** Waits until the Counter is ready for measurement (returns true when ready).

**ctrlInitiate:** Starts the previously configured Counter measurement.

**ctrGetResults:** Reads the Counter results.

## Immobilizers Protect Against Theft

As mentioned above, the advent of RKE is coupled with the need for increased security in cars and the emergence of immobilizers to protect them from theft. As the cost and complexity of the average car rises, so too does the need for greater security to protect it from theft. Car manufacturers as well as insurance companies are raising the standard features on cars. As a result, the industry is moving towards wider use of immobilizers and basic security systems.

Whereas RKE systems provide remote control convenience and vehicle entry security, immobilizers provide protection against vehicle theft. When an improper key is used in the ignition, immobilizers turn off the starter circuit so the engine will not engage.

Immobilizers are composed of a magnetic coil wound around the ignition, a charge and detect module (transceiver) in the ECM, as well as a remote key fob equipped with a transponder. As the action flow in Figure 3 illustrates, immobilizer functionality lies in the signal communication between the transponder and charge/detect module of the ECM so the system can determine whether or not to start the engine. In most cases, immobilizer functionality is part of the BCM while dedicated immobilizer ECMs are uncommon.

## Radio frequency identification (RFID) transponder

The key fob contains a transponder integrated circuit. When the key is placed in the ignition, the integrated circuit induces a current in the magnetic coil surrounding it, thereby exciting the coil, which feeds into a tuned circuit. Once the charge cycle (burst of RF energy) is initiated by the transceiver, the transponder is prompted to transmit its modulated authentication message. This message prompt comes in response to a 120 to 250 ms break in the transceiver charge cycle. The transponder response is generally characterized as AM or FM modulated in non-return to zero (NRZ) mode with duration of < 20 ms.

As in the case of the remote keyless entry key fob, this section of test is customer proprietary and is supplied as either a working fob or black box. Unlike RKE, however, the code is not rolling code. Rather, it is fixed since this communication is not susceptible to code grabbing techniques of thieves.

## Testing

*Improper orientation of the transponder IC in the key fob, 180° rotation for example, will result in a lower level amplitude output from the transmitter. In this case, orientation should be verified by generating the charge cycle and monitoring the transponder IC "word" response amplitude.*

## Agilent TS-5400 Series II and TS-5020 testing solutions

Simulation of the charge cycle may be achieved in two ways: Using the black box or key fob given by the customer as a stimulus; or by emulating the cycle with the automotive-tuned Agilent E6173A arbitrary function generator (a component that can be configured into the test platform).

The test executive software envelope with action routines and test plan examples for the E6173A Arbitrary Function Generator (VXI) or the 33120 (GPIB) supports this hardware solution.

A sampling of the TestExec SL actions for the E6173A ARB include the following:

**arbConfOut:** Configures the ARB's output circuitry.

**arbSet:** Programs the arb by transferring all arb settings specified in the configuration.

**Arb\_DI\_Std\_Waveform:** Downloads a sine, square/pulse or triangle waveform of a specified frequency, amplitude and offset.

**Arb\_DI\_Custom\_Waveform:** Downloads a custom, user-defined waveform consisting of up to 10 sequences with 50 segments per sequence to the Arb.

**arbConfTrigIn:** Sets input triggering parameters.

**arbConfTrigOut:** Sets output triggering parameters.

**arbInitiate:** Starts the arb sequencer to output the waveform.

**arbStop:** Stops waveform output at end of current sequence on a given channel.

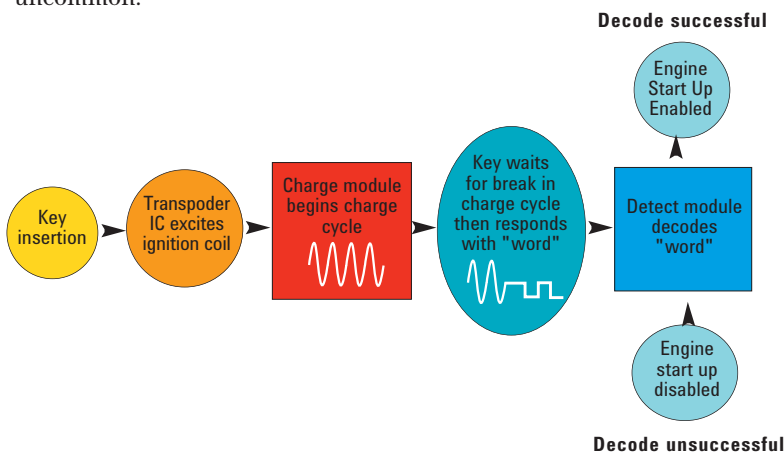

Figure 3: Immobilizer functionality action flow



## Ignition

A magnetic coil wrapped around the ignition is excited by the transponder IC (see Figure 4). The charge module emits a charge cycle  $\leq 12$  Vpp. At the end of the cycle, the module waits until the authentication code from the transponder is detected. Once detected, it is decoded and a serial command is passed to the engine ECM to either grant or deny start-up.

## Testing

Several stages of this process should be tested for system integrity. First, a simple stimulus-response test will determine if the immobilizer decoder is functioning properly. The correct code input is the stimulus, which is either supplied (generally a customer proprietary part of the test) or emulated by use of an arbitrary function generator. Next, the amplitude of the charge module should be checked against design specifications. Finally, verification through serial interrogation will prove that the ECM generated the appropriate serial command to the engine ECM to grant or deny start-up.

## Agilent TS-5400 Series II and TS-5020 testing solutions

These test systems are easily configured to include a custom card for mounting the key fob/black box provided by the customer into the test set-up. The E6173A arbitrary function generator or the 33120 (GPIB ARB) can create a RF charge cycle signal to which the key fob will respond. Verification of serial communication may be accomplished through platform support of the following common interfaces: ISO-9141, J1850, or CAN/J1939.

## An RKE/Immobilizer Test Solution

### Optional throughput multiplier

A dedicated ECM for either RKE or Immobilizer functionality would be characterized as a low pin count/complexity module. Therefore, it is considered a prime candidate for the TS-5400 Series II and TS-5020 optional throughput multiplier. The throughput multiplier facilities multiple up UUT (unit under test) testing. Multiple up UUT testing results in decreased set up time of the instrumentation per UUT, consolidating delays in relay closures and overlapping time delays due to inherent UUT latencies. The TestExec SL software tool provides comprehensive support for this test strategy.

## Automotive electronics manufacturing environment

The TS-5000 family of automotive electronics functional test systems offer support for factory automation. From a more basic automation scheme to the use of PLC (programmable logic controllers), the TS-5400 Series II and TS-5020 test systems have comprehensive serial communication support and digital I/O capabilities allow the platform to be integrated as part of an existing manufacturing environment.

### Overall solution

The test needs for RKE/immobilizer ECMs as generally outlined in this application note, maybe satisfied by the following instrumentation.\*

- RF generator/modulator
- RF spectrum analyzer
- Counter
- Arbitrary waveform generator
- Serial port adapter (for support of ISO9141, J1850 and J1939 serial protocol)
- Power supply
- Measurement control module

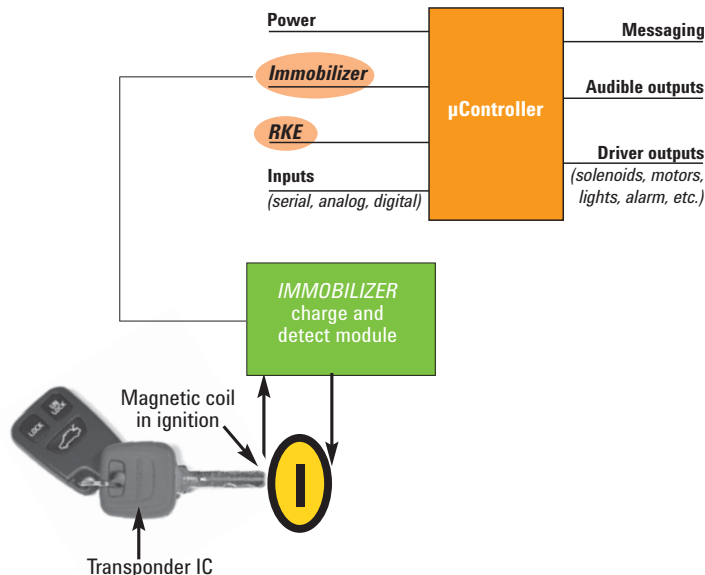

Figure 4: Immobilizer

\* Note: This instrumentation list is presented as a general test solution profile, and is not for use as a direct ordering guide. For information on the detailed platform profile, please refer to the Product Note.

### References

- Jurgen, Ronald. *Automotive Electronics Handbook*. McGraw Hill Inc, 1999.  
Mizutani, Shuji. *Car Electronics*. Sankaido Co, Ltd., 1992.



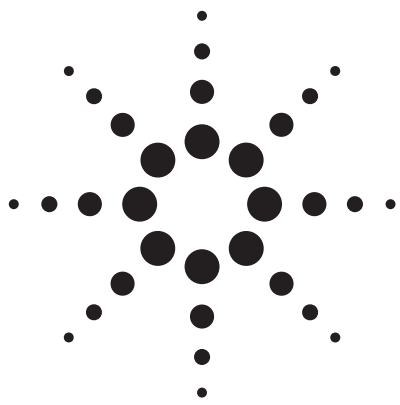

# Testing Supplemental Restraint Systems with the Agilent TS-5000 Family of Automotive Electronics Functional Test Systems

Application Note

## Agilent Technologies TS-5400 Series II and TS-5020 Automotive Electronics Functional Test Systems

### Supplemental restraint systems

A unique aspect of safety electronics for auto-mobiles is the need for redundancy in design and for extensive monitoring, both internal and external, of embedded circuitry. Supplemental restraint systems (SRSs), which control airbags and sometimes seatbelt pre-tensioners, are an increasingly popular feature in cars. The SRS electronic control module (ECM) controls the deployment of airbags (and often seatbelt pre-tensioners) based on the input of electro-mechanical sensors.

Due to the function of the ECM, continuous monitoring and feedback of the power supply circuit, sensors/accelerometer, squib (the airbag igniter), and ECM serial communications is critical.

Monitoring these elements ensures that the ECM will:

- 1) Avoid accidental inflation of the airbag
- 2) Recognize and respond to a legitimate crash
- 3) Return reliable information on system status

Unlike other automotive electronics, SRSs are typically built to act only once during their lifetime, so running a full test of the airbag in production is virtually impossible.

The following is an overview of various manufacturing tests on an airbag ECM designed to increase reliability and system integrity, using the TS-5000 family systems.

### Serial Links

Testing of the ECM involves manipulation and verification of its functionality via a serial link. The common serial interfaces include UART-based ISO-9141, J1850 (pulse width modulated & variable pulse width), and CAN/J1939 (controller area network). These links give the ECM the ability to communicate with external test and measurement instrumentation.

### I/O check

An input/output check may be easily performed by verifying that the ECM correctly reads the states of a given input or output.

### Testing

*Testing the ECM's serial communications can be performed using one of several methodologies based on the ECM's design. Typically, the ECM designer determines the algorithm for setting the module in either TEST or RUN mode. This algorithm – a specific handshake, for example – is often executed in a given time window after the system is powered up (for example, ~500 ms), which is dependent on the specific serial interface chosen.*



## Agilent TS-5400 Series II and TS-5020 testing solutions

In an effort to include the most common serial interfaces, the TS-5400 and TS-5020 test systems feature an optional serial port adapter that supports ISO-9141, J1850, and J1939 serial communications. In addition, the test executive software (Agilent TestExec SL) included with the platform has built-in commands to facilitate serial communication by setting the ECM in either TEST or RUN mode. The software also includes easy-to-use commands for developing a test plan.

Aside from the normal Read/Write/Configure software provided, TestExec SL streamlines common process steps used in functional testing of the ECM – for example, sending the ECM periodic “keep alive” messages (referred to as a ‘group message’ below) to maintain TEST rather than RUN mode is easily executed via the following commands:

**mComConfigGroup:** configures any of the supported serial interfaces for a group message

**mComStartGroup:** specifies the time between groups, between group elements, group repeat count, and the group message itself.  
GroupRepeatCount = 0: represents indefinite repetition of a keep alive message

## System Operation

Two general types of airbag systems are in use in today’s automobiles – centralized and decentralized (see Figures 1 and 2). Both systems rely on a set of crash-detecting sensors and an electromechanical safing sensor (a sensor used as redundancy and/or crash verification). The crash-detecting sensor in a centralized system is a micromachined accelero-meter that is usually housed in the dashboard. However, the crash-detecting mechanism in a decentralized system consists of a distributed set of separate electro-mechanical sensors in the car. The ECM assesses a crash scenario based on the output of its internal “judgment circuit,” which receives input from the crash sensors. Once a pre-defined safety response is determined (based on both occupancy and safing sensors), the squib fires and inflates the respective airbag. Judgment for the airbag deployment should occur in 10 to 30 ms, followed by full inflation of the bag in 30 to 40 ms. Upon total inflation, the airbag absorbs the impact of the individual and then deflates, such that the total time of airbag deployment is typically 100 to 150 ms. In addition, seatbelt pre-tensioners are activated for added protection of the occupants.

## Sensors

In a centralized system, signals from a micromachined accelerometer require an amplifying and filtering circuit to relay the vehicle’s deceleration, while the output requires analog-to-digital (A/D) conversion for use by the ECM’s microcontroller. The electromechanical sensors of a decentralized system are distributed throughout the vehicle and wired in series with the firing squib so that they pass the firing current along when deploying the airbag. These external sensors close an electrical contact when they experience a certain amount of deceleration. Most systems use two to five sensors oriented in series or parallel, depending on their function.

### Short/open sensor

In testing the electromechanical sensors of a decentralized system, the ECM must assess whether the sensor is properly connected (i.e., no opens or shorts). A fault in the sensor connection may result in accidental squib activation and inflation of the airbag.

### Testing

*In production testing, detection of sensor open (due to wiring or mounting), short, or short-to-chassis is done via relay-induced faults. The fault is verified by interrogating the ECM via the serial link and/or by the ECM turning on the warning lamp.*

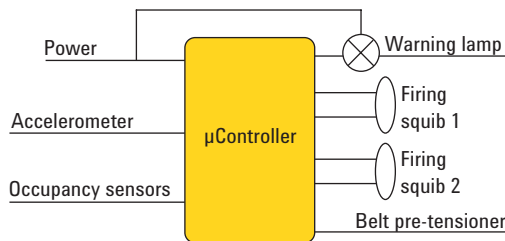

Figure 1: Centralized airbag system

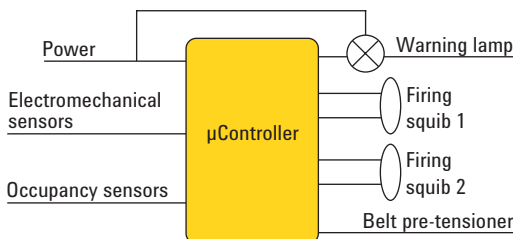

Figure 2: Decentralized airbag system

## Occupancy Sensing

The occupancy sensor input common to both centralized and decentralized systems behaves like an On/Off switch (though electrical devices are also used). As illustrated in Figure 3, the ECM uses input on the presence of a passenger and status of the driver and passenger seatbelts to determine the appropriate safety response (i.e., full airbag deployment, selective deployment, or no deployment).

### Monitoring of occupancy inputs

In accordance with the decision tree in Figure 3, the ECM responds to a given combination of switch closures with an appropriate action. This includes airbag deployment, activation of seatbelt pre-tensioners, switch-on of warning lamp, or other pre-defined actions in the event of "illogical" input (e.g., no passenger present but passenger seat belt on).

Many manufacturers allow for deactivation of passenger side airbags at the owner's request. Seatbelt pre-tensioners are activated only in the event seatbelts are in use. The feedback loops in Figure 3 show that use of passenger and driver seat belts increases the threshold for airbag deployment when the crash scenario is being assessed by the ECM judgment circuit.

### Testing

*Switching element operations are not actively tested. Rather, with a given combination of switch closures, the ECM provides a pre-defined response. Verification of this response is done by ECM interrogation through the serial link.*

## Agilent TS-5400 Series II and TS-5020 testing solutions

The TS-5400 and TS-5020 test systems can be configured to include load cards for either short/open sensor testing or occupancy monitoring. In particular, the E6175A 8-channel load card, E6176A 16-channel load card, or the E6177A 24-channel load card would be appropriate choices; the latter features bridge load capabilities as well. Serial communication from the cards to the ECM takes place through one of the interfaces supported by the platform – ISO-9141, J1850, or J1939.

The TestExec SL software supports a comprehensive signal and load routing architecture. In particular, the switch path editor provides a simple, easy-to-read path description. In addition, for test plans in which relay actions are repeated throughout various sections, relay state tracking recognizes the existing state of the relay, thus speeding the time of test.

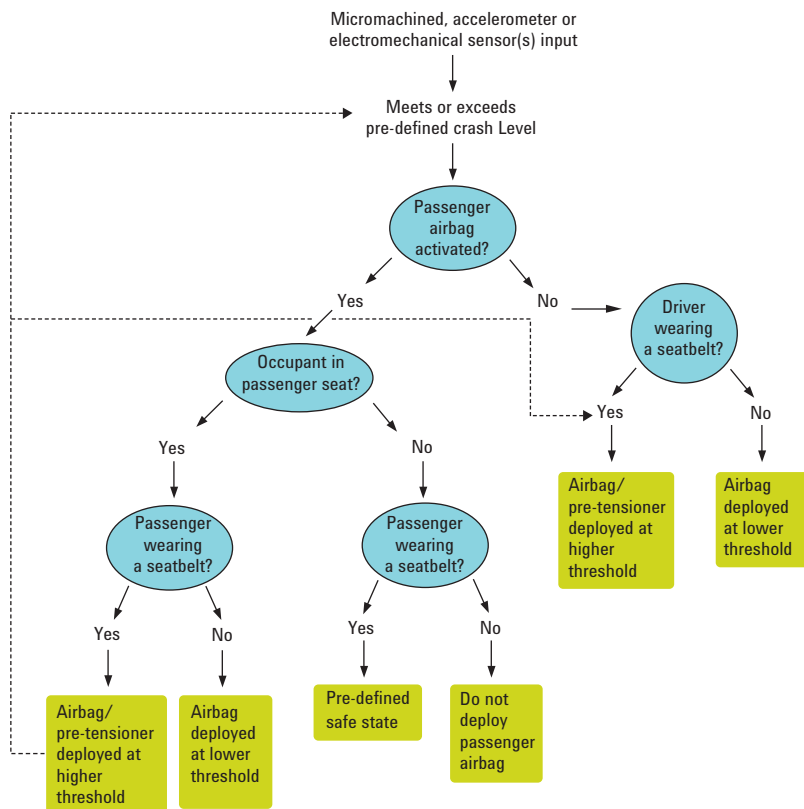

Figure 3: Decision tree used in ECM response determination

## Battery Supply Voltage

In the vehicle, ECM activity relies on the health of the battery voltage (typically 14 V). The supply voltage is used to activate the warning lamp, the seatbelt pre-tensioners, the airbag (through squib firing), and more. In addition, the supply voltage is used by the ECM judgment circuit to establish a threshold value for response in a crash.

### Verifying battery voltage

Verification of battery supply voltage will vary by ECM design. One possible method of testing involves measuring the battery voltage by a voltage divider, an analog-to-digital converter (ADC) reference voltage, and the ADC input of the ECM microcontroller (see Figure 4). The reference voltage is typically 5 V, while the expected ADC output is the ratio between the  $V_{batt}$  input level (battery voltage) and the ADC reference voltage. Another method involves a second, independent reference voltage source, as shown in Figure 5. In this case, the expected ADC output would be equal to a pre-defined value based on the voltage divider input and the second reference voltage input.

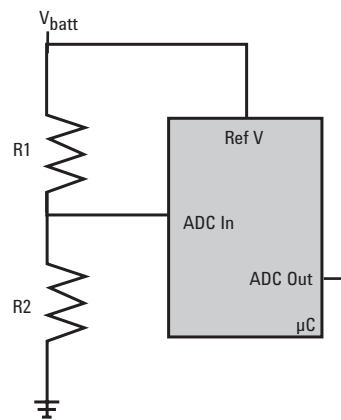

Figure 4: Measuring battery voltage with one reference voltage

### Testing

As noted before, testing of the battery voltage will vary greatly by ECM design. However, in keeping with the two test methodologies shown in Figures 4 and 5, the battery voltage should be applied, followed by verification that the expected ADC output value based on that input matches the real ADC output value as determined through the serial link. For more involved testing, the voltage from the divider at the ECM microcontroller ADC input can also be monitored with a digital multimeter (DMM).

### Agilent TS-5400 Series II and TS-5020 testing solutions

The TS-5400 and TS-5020 test systems feature an optional serial port adapter that supports ISO-9141, J1850, and J1939 serial communication for verification of ADC output. These systems can be configured to include either a GPIB or VXI-based measurement architecture for a DMM to meet these testing needs.

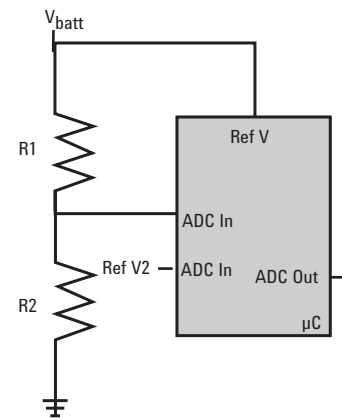

Figure 5: Measuring battery voltage with two reference voltages



## Firing Loop For Airbag Deployment

To deploy an airbag in a crash, the ECM passes current through the firing loop into the firing squib to ignite the gas within the airbag. As illustrated in Figure 6, in addition to the cable and connector resistance, the firing squib is also modeled as a resistor in this loop. If the resistance in the firing loop falls above or below an established range, the warning lamp is activated.

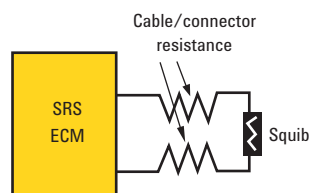

Figure 6: Airbag deployment firing loop

### Verifying the Firing Loop Resistance

If the resistance in the firing loop falls above or below an established range of operability, the warning lamp must be activated.

#### Testing

*Testing the firing loop involves several steps. First, the current from the ECM through the loop must be verified. Second, it is important to monitor the voltage drop across the squib (if using a real squib) or use a DMM to obtain the resistance of the cables and connectors (when the squib is modeled as a resistor). These values may be obtained based on several fault scenarios (e.g., open or short in the loop). Finally, with the advent of firing squib serial communication capability, verifying firing loop resistance via a serial link to the squib is also possible.*

### Agilent TS-5400 Series II and TS-5020 testing solutions

The TS-5400 and TS-5020 test systems can be configured to include several different load cards for this application. Emulating a short or open condition in this loop, therefore, may be done via relay-induced faults using any one of the load cards. However, the E6175A 8-channel load card and E6176A 16-channel load card also feature 50 mΩ-sense resistors for current sensing.

## A Supplemental Restraint System Test Solution

### Optional throughput multiplier

The TS-5000 family of automotive electronics functional test systems may be configured to include an optional throughput multiplier, which is often used when testing low pin-count/low complexity ECMs. The throughput multiplier facilitates multiple-up UUT (unit under test) testing. Multiple-up testing results in decreased instrumentation setup time per UUT, consolidating delays in relay closures and overlapping time delays due to inherent UUT latencies. The TestExec SL software provides comprehensive support for this test strategy.

### The automotive electronics manufacturing environment

The TS-5000 family of automotive electronics functional test systems offer support for factory automation. From a basic automation scheme to the use of PLCs (programmable logic controllers), the TS-5400 Series II and TS-5020 test systems have comprehensive serial communication support and digital I/O capabilities that allow the platform to be integrated into the overall manufacturing environment.

### Overall solution

The test needs for a supplemental restraint system ECMs as generally outlined in this application note, may be satisfied by the following instrumentation.\*

- Digitizer
- Digital multimeter
- Serial port adapter
- Select load cards

This added functionality facilitates current verification from the ECM through the firing loop. The voltage drop across these sense resistors can be measured by using a digitizer or DMM (also configurable with the platform).

For monitoring the voltage drop across the squib, the TS-5400 and TS-5020 test systems can be configured to include either a VXI- or GPIB-based DMM. When the squib is modeled as a resistor, the resistance at the inputs to the squib may be verified with the DMM's four-wire resistance capabilities.

Finally, these test systems include support for ISO-9141, J1850, and J1939 serial protocols when obtaining firing loop resistance information via the serial link.



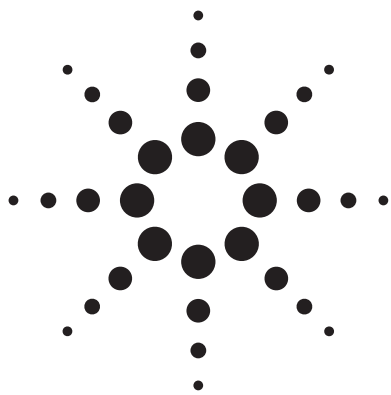

# Using Agilent 6690A Series System DC Power Supplies for Automobile Battery Simulation

## Application Note

Minimize your testing downtime with this reliable, high power DC supply

- Low ripple & noise
- Fast up-and-down programming
- High accuracy current programming and read back
- Industry standard SCPI programming commands
- Analog programming
- Analog monitoring
- Full protection from overcurrent, overvoltage, overtemperature
- Remote sense
- Electronic calibration
- Standard 3-year warranty

In the past few years, the electronic content of automobiles has been increasing at a fast rate, resulting in higher battery currents. Combine that with efforts to improve efficiency; today's 12 V car battery is just not adequate for the cars of the future. The trend is for higher voltage, which



will lower the current, resulting in savings in the wiring harness and other components used in cars.

42 V is becoming standard voltage for the battery. However, because of load changes during the operation of the vehicle, that voltage may reach up to 60 V or go as low as 25 V. The new 42 V battery will have different requirements for duty cycle and total power capability than the 12 V battery. Under the start/stop scenario of the future vehicles, the number of starts and stops that the battery will

endure could increase by a factor of more than 10. This loading puts more strain on the battery and other components used in the car. The Agilent 6692A power supply is ideal for simulating the battery under all loading conditions. This power supply can also be used to test electronic equipment while simulating actual battery voltage fluctuations.



During the developmental phase, Agilent power supplies undergo a battery of environmental tests such as an 8-day temperature profile. Other tests include humidity, altitude, shock and vibration, ESD, AC line tests, EMC and RFI. The power supplies are designed with built-in margin so that they can meet their specifications over time, under all conditions, and also withstand peak stress.

Wide design margins and stringent environmental tests translate into reliable products. To you, it means lower cost of ownership, minimum downtime and faster delivery of your electronic equipment/components to your customers.

## Specifications

Parameter	Agilent Model Number			
	6690A	6691A	6692A	
<b>Output Ratings</b>				
<b>Voltage:</b>	0 - 15 V	0 - 30 V	0 - 60 V	
<b>Current:*</b>	0 - 440 A	0 - 220 A	0 - 110 A	
*Derated linearly 1%/°C from 40°C to 55°C				
<b>Programming Accuracy (@ 25 ±5°C)</b>				
<b>Voltage:</b>	0.04% +	15 mV	30 mV	60 mV
<b>Current:</b>	0.1% +	230 mA	125 mA	65 mA
<b>Ripple &amp; Noise</b> (from 20 Hz to 20 MHz with outputs ungrounded, or with either output terminal grounded)				
<b>Constant Voltage:</b>	rms	2.5 mV	2.5 mV	2.5 mV
<b>Constant Voltage:</b>	p-p	15 mV	25 mV	25 mV
<b>Constant Current:**</b>	rms	200 mA	50 mA	30 mA
**With load inductance >5µH.				
<b>Readback Accuracy</b> (from front panel or over GPIB with respect to actual output @ 25 ±5°C)				
<b>Voltage:</b>	0.05% +	22.5 mV	45 mV	90 mV
<b>±Current</b>	0.1% +	300 mA	165 mA	80 mA
<b>Load Regulation</b> (change in output voltage or current for any load change within ratings)				
<b>Voltage:</b>	0.002% +	650 µV	1.1 mV	2.2 mV
<b>Current:</b>	0.005% +	40 mA	17 mA	9 mA
<b>Line Regulation</b> (change in output voltage or current for any line change within ratings)				
<b>Voltage:</b>	0.002% +	650 µV	650 µV	650 µV
<b>Current:</b>	0.005% +	40 mA	17 mA	9 mA
<b>Transient Response Time</b> (for the output voltage to recover to within 150 mV following any step change from 100% to 50% or 50% to 100% of the rated output current): <900 µs				

For more information regarding Agilent's DC power supplies, visit our Web site at: <http://www.agilent.com/find/power>

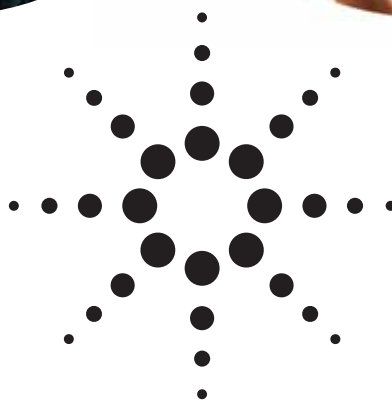

**Agilent TS-5020  
Tire Pressure Monitoring  
System (TPMS)**

Application Note



## Tire Pressure Monitoring System (TPMS)

Safety electronics in automobiles continue to be designed and enhanced to add for passenger safety. The Tire Pressure Monitoring System (TPMS) is a safety feature that updates drivers on their tire pressure level from within the comfort of the car cabin.

Studies have shown that it is very common to have running tires with low air pressure, hence tire pressure monitoring is an important safety factor throughout the automotive industry. The US government has passed a legislation that requires all passenger cars and small trucks with gross vehicle weight of less than 10,000 pounds to be equipped with TPMS. The main purpose of the TPMS is to warn drivers of the loss of pressure in their tires for greater safety and automobile handling performance.

### Agilent TS-5020 TPMS Solution

The TS-5020 TPMS is an enhanced solution using Agilent's existing TS-5020 as its base platform. With the built-in Agilent 34980A Switch/Measurement Unit, the TS-5020 base platform comes equipped for RF measurement use. Adding a signal generator and spectrum analyzer connected via RF extends its application as a RF parametric tester. Basic RF measurements, such as power level, spurious, phase noise, adjacent channel power etc, can be measured using signal generator ESG4432B and spectrum analyzer ESA4402B.

### TPMS Operation

A conventional TPMS module consists of pressure and temperature sensors attached to each wheel with a data transmitter, and a central receiver mounted on the central body. The operating frequency uses ISM band of 315, 434, 868 and 915MHz with typically an ASK/FSK modulation scheme.

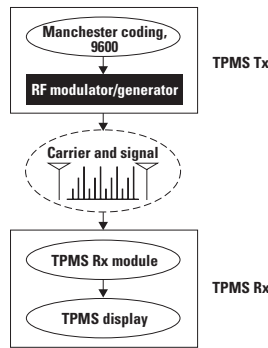

Figure 1: TPMS Functionality Action Flow

Electronically, the TPMS module functionality lies in translating the coded input from each wheel, into the receiver module to display the pressure level.

Figure 1 depicts its functionality. Typically the data format is sent at 9600 bps and Manchester encoded using FSK/ASK modulation. Manchester encoding is described as a digital signal in which values transition between high and low halfway through each bit period.

### TPMS Transmitter

In Figure 1, the transmitter includes a tire identification integrated circuit which is powered by a lithium cell battery. The tire ID is typically 32 bits in length. The TPMS transmitter module is based on low battery consumption and thus the components within must have minimum current requirements and use very little energy. Typical active operating current is approximately 1 to 5 mA and 100 nA during stand-by mode.

### Testing

The testing of the transmitter module involves checking signal power level, frequency deviation (FSK), and burst measurement (ASK), demodulation of ASK/FSK signal. A wakeup signal of 125 KHz is needed by the DUT to "wake-up" the microcontroller to generate continuous RF transmission. To conduct these tests, an appropriate spectrum analyzer should be selected.

## The Agilent TS-5020 TPMS Testing Solution

Agilent spectrum analyzer ESA4402B is selected as a TS-5020 TPMS standard option to perform power level and demodulation analysis. Other ESA models can also be used, but due to the low operating frequency, this model will suffice for the test. Figures 2 & 3 depict the ESA4402B capability to measure the frequency deviation and demodulation data bits respectively.

The test executive, TestExec SL has several capabilities to conduct power level measurement, center frequency determination, bandwidth, etc. The action tests can be retrieved by inserting the action it TestExec SL. Following is an example of some of the actions written for ESA:

- esaSetFreqSpan
- esaSetFreqCenter
- esaSetBandwidth
- esaMarkerPeakSearch
- esaSweepSetTime
- esaMeasFreqDev

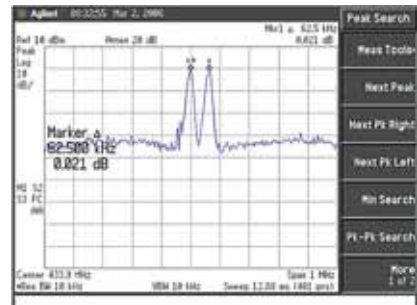

Figure 2: Frequency Deviation on ESA4402B

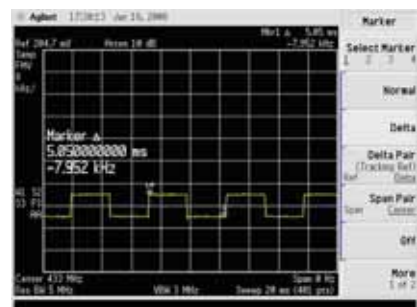

Figure 3: Data bit on ESA4402B



In Test Exec SL, each ESA action will have its own function description. Parameters can be keyed in by user to perform measurement or setup.

## RF Generator

The RF generator modulates the carrier signal, creating an output for the TPMS receiver. TPMS RF bands are typically 315MHz in the United States/Japan and 433/868 MHz in Europe. To test the receiver module, a signal generator is required to simulate the signal. The specifications of the signal generator may be determined by customer needs and selected from various Agilent signal generators. This is not a standard option for Agilent TS-5020 TPMS solution as some users do not require a signal generator to conduct receiver tests. The Agilent model ESG4432B is selected here as an example to generate ASK/FSK signals.

A few Test Exec SL actions related to the signal generator is as follows:

- esgSetPowerStatus
- esgSetPower
- esgSetFrequency
- esgFSKConfig
- esgCustommode

### During Receiver Test

After a data frame is received, the tire ID will be compared to the other four tire IDs stored in the memory. If an ID match is found, the pressure data will be processed and the particular tire indicator will be lit if low tire pressure is detected. Finally, the data frame is sent through the serial interface for external data acquisition and storage.

### Calibration Path Loss

With the ability of the TS-5020 base platform to be extended as a RF Parametric tester, a calibration path loss solution has been included into Test Exec SL. However, the solution is based on ESA4402B spectrum analyzer, ESG4432B signal generator and E4416 power meter. The example program and calibration file is saved in the following directory:

- C:\Program Files\Agilent\TS-5400 System Software\Testplan\Dgn\TPMS\_Dgn.tpa
- C:\Program Files\Agilent\TS-5400 System Software\Bin\TPMS\_Pathloss.csv

The setup of calibration path loss procedure can be achieved if users choose not to use the above model. Users who are familiar with message based instruments can use TestExec SL to communicate with the respective equipments.

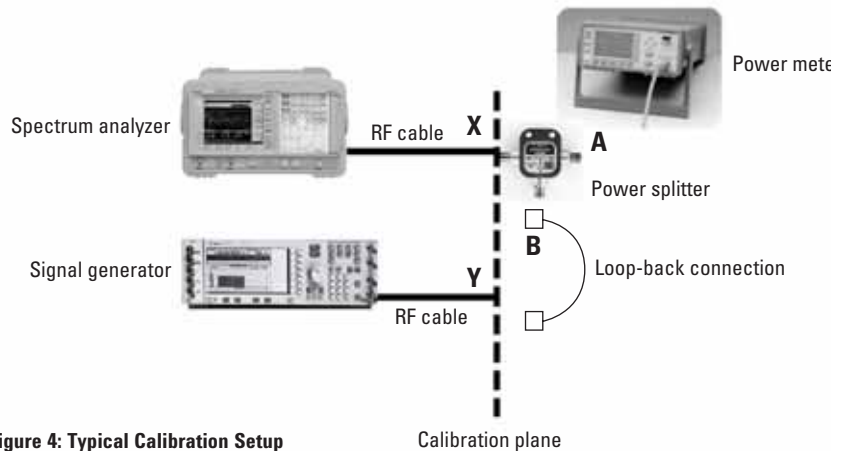

Figure 4: Typical Calibration Setup

Figure 4 depicts the concept of measuring path loss on a TS-5020 base platform: The above diagram illustrates path loss measurement by using a signal generator to source the signal via a loop back connector to a spectrum analyzer to measure its signal loss. A power splitter and power meter is used to measure the power level at the specified calibration plane. Following procedures are examples on how to measure path losses.

### Path Loss Measurement @ Calibration Plane X

- Signal generator to source the CW signal at frequency of calibration (for example: 315 MHz). ALC is set to internal level

- A power sensor is used to measure the power level at Point A for a set value (for example: 0 dBm). NOTE: Power level at Point X and A should be equal
- The signal generator is adjusted until the required set power level is obtained
- Path loss (dB) between Point X and input to the spectrum analyzer would be the difference of power measured by the spectrum analyzer and the set power level

### Path Loss Measurement @ Calibration Plane Y

- Signal generator to source the CW signal at frequency of calibration (for example: 315 MHz) and a specified power level (for example: 0 dBm). ALC is set to internal level. NOTE: Power splitter and loop-back connectors are not required in this case
- Use a power sensor to measure the power level directly at Point Y.
- WARNING: Make sure the source power level setting does not exceed the absolute maximum rating of the power sensor.
- Path loss (dB) would be the difference in power level measured at Point Y by the power sensor and power set for the signal generator.



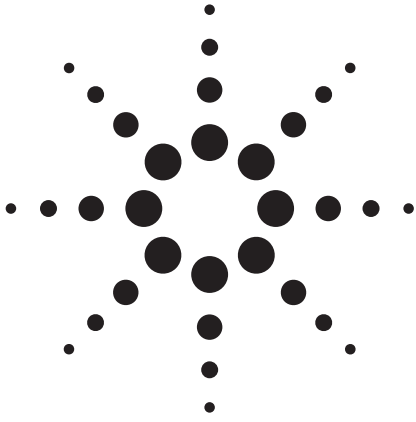

# TS-5400 Series II Automotive Electronics Functional Test System

## Application Note

### Test Engineering Challenges

On time test deployment within budget is your department's responsibility. To accomplish this, the test system utilized must provide adequate test coverage and test times while ensuring the manufacture of quality products. In developing a test platform, you must balance three competing goals: **time** (test development, execution and system deployment); **cost** (capital and integration); and **scope** (throughput, accuracy and flexibility) [see Figure 1]. Competing in today's automotive electronics manufacturing environment means using reusable, scalable test platforms that meet the evolving test requirements of electronic control modules and smart sensors.

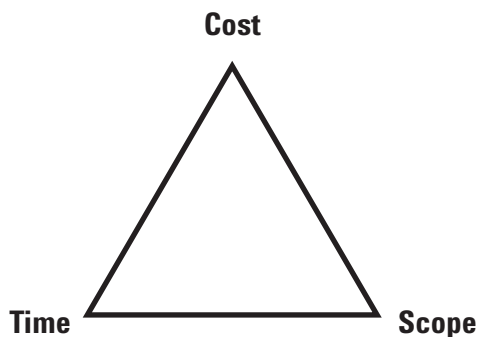

Figure 1: The Balancing Challenge

There are three approaches to choose from when creating a test system: use your in-house test department to build your own, outsource the development of the entire system, or use a commercial off-the-shelf platform as the basis for the test system to be deployed. The Agilent Technologies TS-5400 Series II is a commercial, off-the-shelf platform tuned specifically for automotive electronics functional test.

Measurements in Electronic Control Modules (ECMs) are challenging today, and new developments for engine management systems, powertrain control, safety, security and convenience modules promise to make them even more challenging down the road. This platform facilitates test strategies for ECMs in current production with the ability to adapt to a wide range of possible ECMs in future production. What's more, users of the TS-5400 Series II have reported **time-to-market improvements of 300%**.

### Manufacturing Goals

Producing quality ECMs faster and at a lower cost than the competition, without compromising test coverage, can be an overwhelming challenge in the fast-paced automotive electronics industry. In exploring the three competing goals [see Figure 1], the need to focus on each individually, while simultaneously studying how they relate to one another, becomes increasingly clear. Meeting the tremendous deadline pressure to get manufacturing test lines set up on **time** requires test engineering to perform faster test development, execution and line integration. In turn, increasing throughput to decrease the test **cost** per ECM requires faster test execution while maintaining a high level of test coverage. And finally, test coverage and capability depend on the flexibility in the **scope** of the test system to accommodate the rapid introduction of new convenience, security, safety and engine management ECMs.

Achieving the proper balance among all three goals is difficult yet necessary for manufacturers to better meet OEM timelines. In an effort to find this



balance, where time is the ultimate constraint, manufacturers are forced to make decisions on trading test coverage for maintaining a lean time-to-market. Or, manufacturers are forced to make decisions on trading wide ranging, flexible ECM test capability for module-dedicated test systems – a poor use of assets in the long term. Making a decision between issues of quality and test system capabilities is a choice no manufacturer should have to face. That’s why Agilent is pleased to introduce a competitive new test system that lets you have it all: quality test coverage, lower test **cost** per ECM and flexibility in **scope** – all at a faster **time** to market.

### The Agilent Solution

The TS-5400 Series II automotive electronics functional test system helps manufacturers get their products to market faster by accelerating test system deployment. Engineered with the three critical manufacturing goals in mind, this family of platforms provides flexibility, speed and quality to automotive electronics production. When it comes to flexibility, a universal test system core of both hardware and software can easily be modified to suit your particular test strategy and range of ECMs. As for speed and quality, an enhanced test executive accelerates both the development and execution of tests with over two hundred automotive applications-tuned libraries.

Four base platforms test the range of automotive ECMs. From simple ECMs, like climate control, immobilizers and RKE (remote-keyless entry), to safety ECMs such as airbag and ABS/TC to complex ECMs like engine management systems, the TS-5400 Series II meets the price/performance required. These platforms [see Figure 2] are tuned for automotive electronics functional test and consist of measurement resources, switching, a test executive and automotive tuned library routines. Racking, cabling and optional fixturing are included, as well as standard software development tools that enable test engineers to deploy test systems **up to three times** faster than building test systems from individual components.

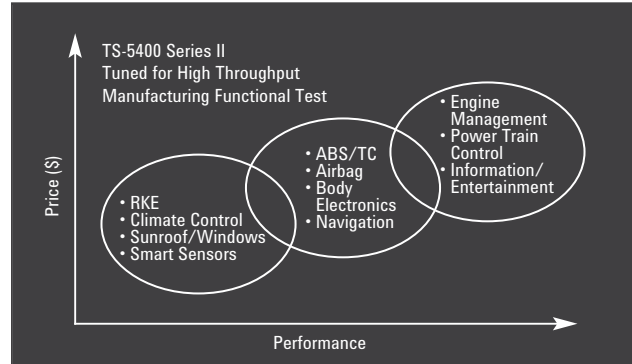

Figure 2: The TS-5400 Series II Tests the Range of ECM Complexity/Pin-Count

### Just Enough Test

With the growth in convenience and safety ECMs, test engineering needs to meet the production throughput goals at a cost of test that remains competitive in today’s market and tomorrow’s. The measurement envelope for convenience ECMs is not as demanding as those for safety and engine management systems. Recognizing this, the TS-5400 Series II comes in two powerful configurations to meet the given ECM test requirements [see Figures 3 & 4].

As a result of the TS-5400 Series II unique architecture, you can now purchase “**Just Enough Test**” resources to meet current ECM test requirements, then add test capabilities to the system when new ECMs move into production.

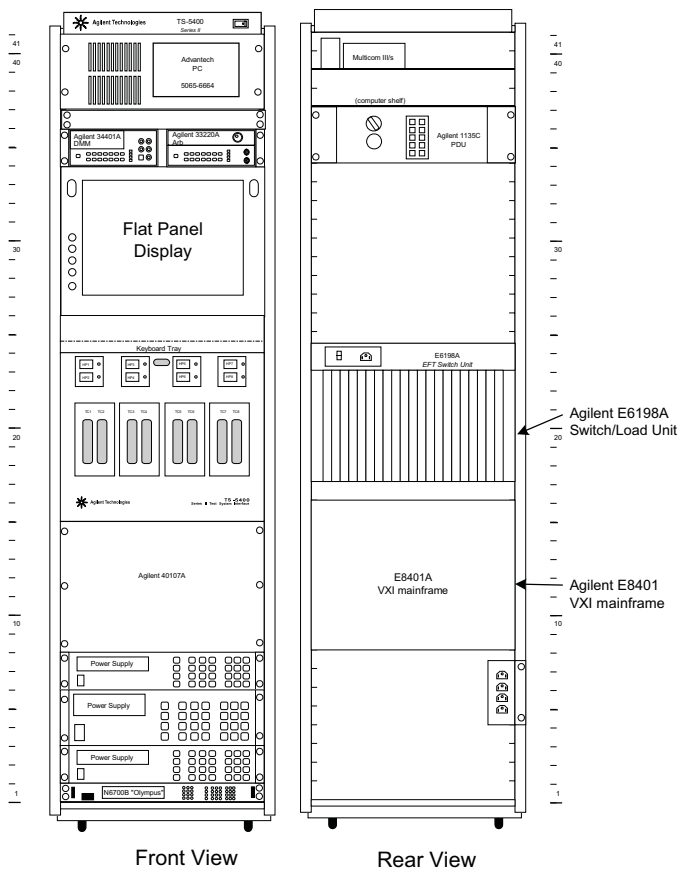

Figure 3: VXI/GPIB Express Connect (front and rear views)

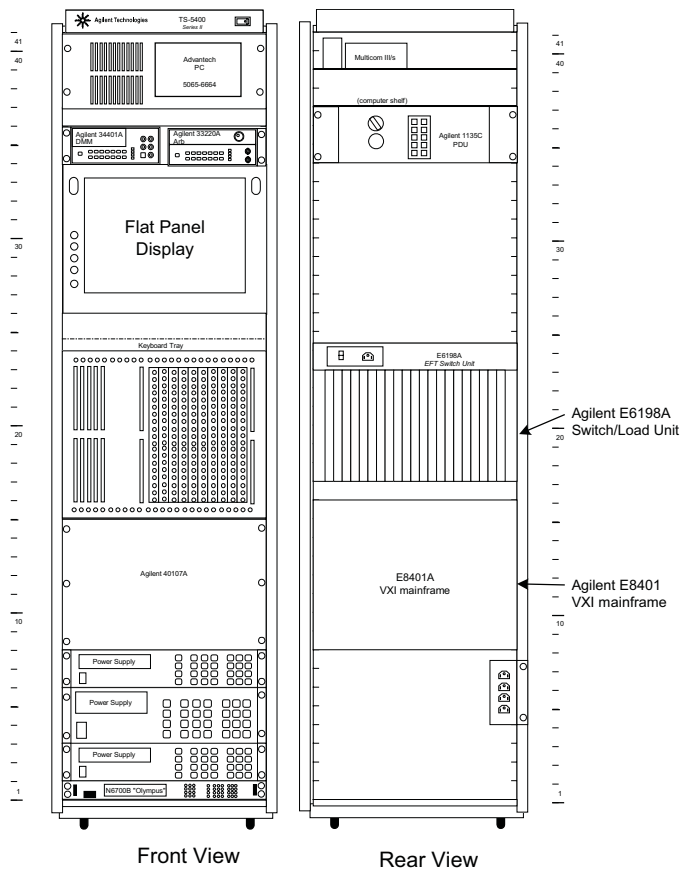

Figure 4: VXI/GPIB Mac Panel (front view and rear views)

### TS-5400 with Express Connect Interface – Medium-to-High Pin Count Application

For the medium to high pin-count/complexity ECMs, the measurement engine is VXIbus-based with a DMM, Measurement Control Module (MCM), Event Detector, Arbitrary Function Generator (ARB), Digitizer, Counter, and other optional VXI-based instrumentation. Optional GPIB instruments may be configured. As in the low pin-count/complexity ECU platform, all switching (instrumentation, power supply and load) resides in the Switch/Load Unit. The Express Connect Interface [see Figure 3] consists of one Switch/Load Unit. This system uses the IEEE-1394 FireWire for VXI I/O and GPIB for all IEEE-488 instruments (power supplies and additional optional message-based instruments).

### TS-5400 with Mac Panel Interface – High Pin Count Application

This high-performance throughput system uses the MXI-II interface for the VXIbus I/O. It's a platform that yields 5% greater throughput; valid on high-end ECMs [engine control/management modules and powertrain control] when the highest tester throughput is desired.

All the test platforms use an enhanced version of TestExecSL. The latest version of the test executive software allows for faster test plan development, easier integration of message-based instruments (adding VXI or GPIB optional instruments) in addition to the ability to support test plans from the Agilent TS-5400 Series I. The optional "Throughput Multiplier" for simultaneous testing of multiple modules or Units Under Test (UUT) is also available.

## Throughput Multiplier

The Throughput Multiplier test strategy (multiple-up UUT testing) is one way to increase throughput for a manufacturing environment. Multiple UUT testing not only consolidates tasks common to multiple modules, such as load/unload, instrument set up of signal and load routing, it's also an effective strategy for overlapping inherent latencies in the UUT or test system [see Figures 5 and 6].

### Testing

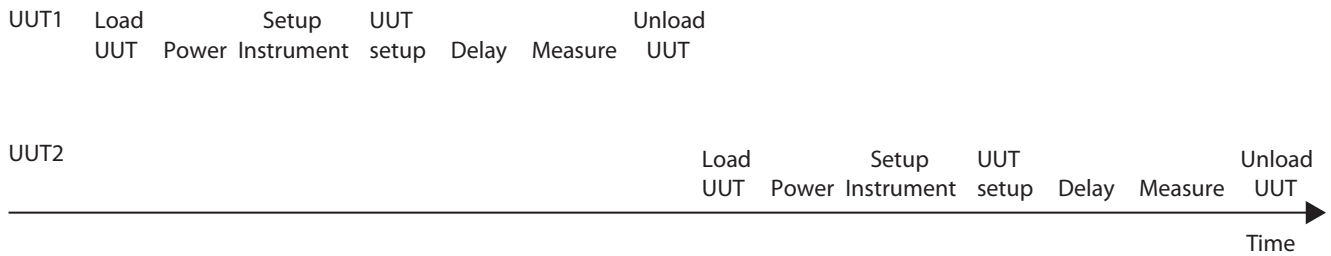

Figure 5: Single-Up UUT Testing

### Testing

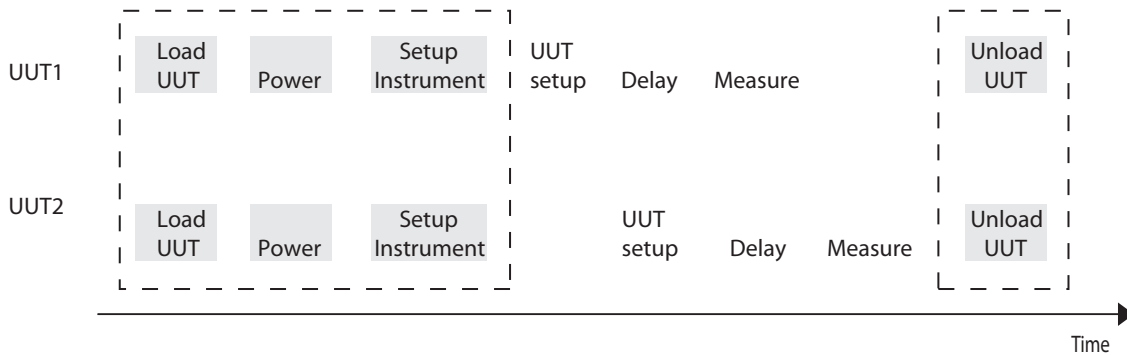

Figure 6: Multiple-Up UUT Testing



## Test Requirements and Methodologies

### Serial

Most ECM designs include a serial interface as shown in Figure 7. Communication protocols vary by manufacturer, but most comply with OBD2 standards. Variations include ISO-9141, J1939/CAN and J1850. The serial link is used in the automobile itself, but can also assist in the testing of the module. Test code (as opposed to operational code) is either included in ROM or downloaded through the serial link into the module. Operational code is either present in ROM during test or is downloaded when the unit is shipped. Using test code routines as part of the test program, the test system establishes a set of conditions to which the ECM responds. This test approach is called **UUT-Assisted Test**.

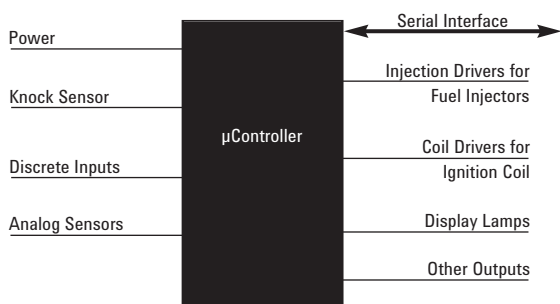

Figure 7: Serial Interface for Engine Control ECM

### UUT-Assisted Test

For clarity, consider three different modes for performing UUT-Assisted Test. The mode chosen will be defined by the test stimulus source and response destination.

*Serial Link Evaluation:* This first mode simply evaluates the serial link and microcontroller. Commands received by the microcontroller over the serial link prompt a serial response that is sent back to the test system. The system then verifies the response and it may follow with a full CRC memory check. Parametric tests may also be run to test the serial link's characteristics, such as delay, rise and fall times, and input impedance.

*I/O Status Evaluation:* This mode uses the test system I/O to determine the ECM input states. This is accomplished by sending a message over the serial link to the ECM prompting it to run one of its loaded test routines. For example, use of this mode may occur when supplying an analog input into the system to verify the A/D conversion and the controller's handling and communication of the proper (hex) data over the serial link. Specifically, this analog input may be a simulation of a sensor's output for air or water temperature, the Throttle Position Indicator (TPI), Manifold Air Pressure (MAP) and the like. This mode illustrates how UUT-assisted testing allows the test system to assess proper functioning of several functions at once—including the controller and serial link. In addition, the system can assess the A/D and waveform processing circuitry.

*Input Evaluation:* The final mode involves the test system supplying input, then reading the value at either the input or output of the module. For example, this would include dynamic tests such as the application of a cam/crank phase synchronous waveform, (MAP or TPI input). This evaluation would verify if the signal is read correctly at the input of the module or if the given signal prompted the appropriate response at the module's output.

## What Makes Automotive Functional Testing Unique

Testing of automotive ECMs requires an understanding of the key characteristics in design and manufacturing. What follows is a description of the general requirements for testing an automotive ECM (using an engine control module as the unit under test). Next, you will find an overview of the TS-5400 Series II system architecture illustrating its benefits as a functional test solution for automotive electronics.

Characteristics of Testing Engine Management ECMs	The Agilent TS-5400 Series II Solution
Fast Switching for Multiple Signal and Load Routing	<ul style="list-style-type: none"> <li>• Programmable Switch/Load Unit</li> <li>• Multiple Load Card Capabilities with Fast Relays</li> <li>• 42V Ready Solution</li> <li>• Pull-Up and Pull-Down Load Capabilities</li> <li>• Bridge Load Capabilities</li> </ul>
"Real World" Waveform and Signal Generation	<ul style="list-style-type: none"> <li>• Variable Reluctance and Hall-Effect Sensor Simulation</li> <li>• Knock Signal Simulation</li> </ul>
High Current/Voltage Response Handling	<ul style="list-style-type: none"> <li>• Flyback Voltage/Current Handling</li> <li>• Voltages up to 500V, Currents up to 30A</li> <li>• Period, Frequency, Timing and Duration Measurement Capabilities</li> </ul>
Serial Communication	<ul style="list-style-type: none"> <li>• ISO-9141 Capability</li> <li>• J1850 Capability</li> <li>• J1939/CAN Capability</li> </ul>
Requires High Throughput (<20s for 100 pin-count ECM)	<ul style="list-style-type: none"> <li>• Optimized Software (fast sequences, pre-compiled tests, state tracking)</li> <li>• Fast (0.5ms) measurement matrix relays</li> </ul>

**Table 1: Engine Control ECM Testing Characteristics and the TS-5400 Solution**

Testing engine management system ECMs presents the most difficult challenge for today's automotive electronics test systems. These modules require a dynamic range of both stimulus and response signals with flexible loading, high-speed, high-resolution measurements and comprehensive serial communication capabilities. In fact, many of today's systems require two minutes or more to test a single, 100-pin module. Engineered with the unique challenges of automotive electronics testing in mind, the TS-5400 Series II reduces this time to twenty seconds, thus increasing production volume while greatly reducing the cost of test. In short, developers of the TS-5400 Series II are committed to helping customers create the greatest quantity of quality electronics in the shortest time possible – all at the best price/performance possible.

The first four sample tests listed provide assurance to continue with the elements of dynamic testing such as fuel injection pulse timing and width, coil flyback voltage, spark advance behavior under MAP, TPI and knock signal input of variable amplitude.

For other modules, the Power Up, Analog Sensor Input, Input Pin Parameter and Output Pin Parameter tests would be similar in nature, while the dynamic tests may vary. Engineered to empower manufacturers in their choice of module classes, the flexibility of the TS-5400 Series II allows you to introduce a variety of measurement envelopes to meet a given module's testing needs.

Sample of Tests for Engine Control ECM	Sample Measurements
Power Up	<ul style="list-style-type: none"> <li>• Input Current</li> <li>• Input Capacitance</li> </ul>
Analog Sensor Input	<ul style="list-style-type: none"> <li>• Response to Analog In</li> </ul>
Input Pin Parameter	<ul style="list-style-type: none"> <li>• Input Bias</li> <li>• Clamp Voltage</li> <li>• Leakage Current</li> <li>• Pull-Up Loads</li> <li>• Pull-Down Loads</li> </ul>
Output Pin Parameter	<ul style="list-style-type: none"> <li>• Saturation Voltage</li> <li>• Leakage Current</li> <li>• Flyback Voltage</li> <li>• Smart Driver Timing</li> <li>• Duration of Flyback</li> </ul>
Dynamic	<ul style="list-style-type: none"> <li>• Spark Advance (MAP, TPI varying) relative to TDC</li> <li>• Timing and Width of Fuel Injection Pulses</li> </ul>

**Table 2: Sample Tests and Measurement for an Engine Control ECM**

## The Agilent TS-5400 Series II Architecture

The TS-5400 Series II is designed to help accelerate test system deployment while ensuring quality measurements at an industry leading uptime. The overall TS-5400 Series II architecture [see Figure 8] consists of a Windows NT based controller running TestExec SL software with hundreds of pre-tested automotive-tuned library routines. The controller is connected to the primary Switch/Load Unit (SLU) via parallel interfaces (additional SLUs may be configured by extender cables from the primary SLU). The controller is also connected to the instrument set, including power supplies, through a GPIB interface (for IEEE-488 instruments) and a high-speed interface (for VXIbus-based instruments) and RS-232 (for ODB2 serial).

## 21-Slot Switch/Load Unit

The true core of the platform lies in the Switch/Load Unit. The programmable Switch/Load Unit is used for instrumentation switching (GPIB, Serial or VXIbus-based), plus switching power supply and loads to the ECM. Test system resources (instrumentation, loads and power supplies) are routed to the UUT through the Pin Matrix cards and load cards that plug into the Switch/Load Unit. There are four types of load cards and two types of pin matrix cards.

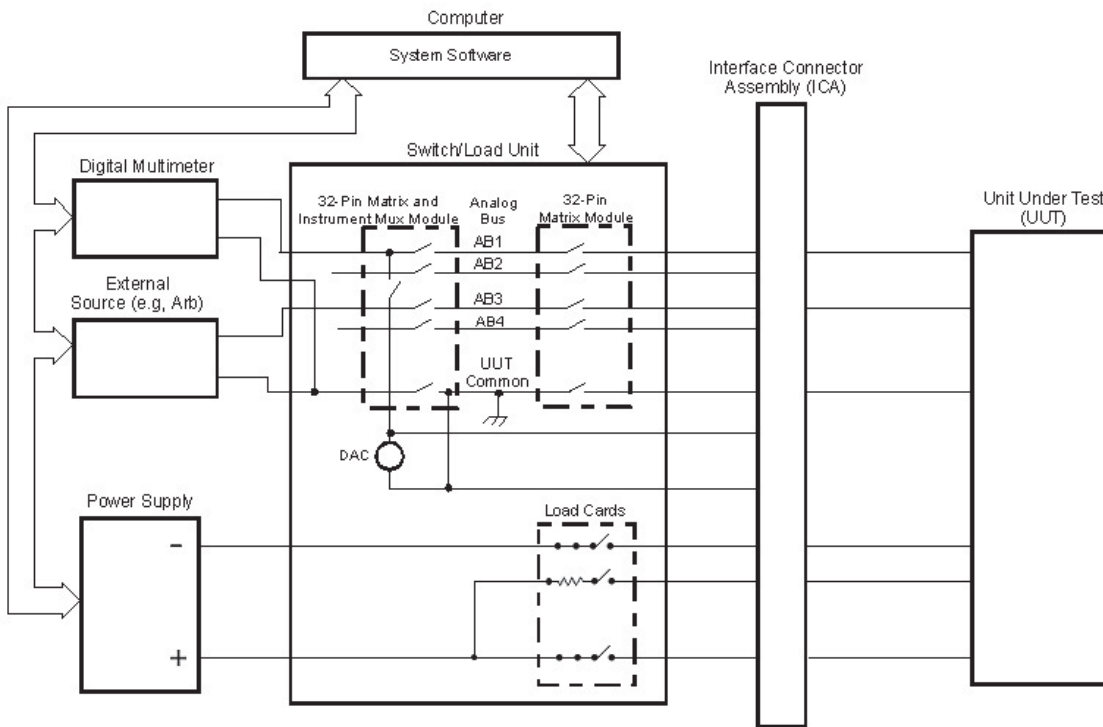

Figure 8: System Architecture for the TS-5400 Series II

### Load Cards

In an automotive electronic system there are many special load requirements, from simple resistive loads to highly inductive loads (such as the ignition coil). In many cases it's crucial to simulate the load, while in others an actual load is used to gain accurate visibility into the performance of the UUT. The Switch/Load Unit is designed with a flexible load topology capable of meeting either load strategy. The four types of load cards are described in Table 3. Provisions to measure the current through any load channel have been designed with sense resistors available on the 8- and 16-channel load cards.

### Pin Matrix Cards

These cards consist of a 32x5 matrix, which provides fast connections into or out of the system for 32 rows into 4 columns (the fifth column is UUT ground). The four columns are collectively referred to as the A-Bus. The matrix has a 0.5ms switching time, ~60 times faster than standard off the shelf VXIbus-based matrix switches (20-30ms).

High reliability switching (typically 108 cycles) is assured through jumper removable protection resistors on the card. Additional pin matrix cards may be added to increase the system pin-count capabilities. The E8792A is a 4x16 matrix with an additional line for UUT Common. These four channels can be routed to 32 pins on the UUT. Disconnect relays allow you to build large matrices (>150 pins) without degradation. For applications requiring more than 32 channels, the E8793A Pin Matrix card (without the 4x16 instrument matrix) may be used for increasing channels in increments of 32. The A-bus is daisy-chained from card to card to route the 16 instruments to N\*32 channels, where N represents the number of Pin Matrix cards including the E8792A. Automatic switching permits a simple programming model.

### Custom Card

With the custom card, test engineers are assured compatibility when using the TS-5400 Series II. In addition to that, should test engineers require custom circuitry, the custom card may be used as a breadboard. The card is also useful in Express Connect systems for routing of auxiliary relays.

Load Card	Features
E6178A 8-Channel Heavy Duty	<ul style="list-style-type: none"><li>• 30A continuous, 200A Surge Capabilities</li><li>• Engineered for Applications from Antilock Brake Systems to Engine Control and other Motor Applications</li></ul>
E6175A 8- and E6176A 16-Channel	<ul style="list-style-type: none"><li>• Current Sense Capabilities</li><li>• 7.5A Continuous, 15A Peak</li><li>• High Current Protection Circuitry</li><li>• Engineered for High Voltage Flyback Inductive Load Applications</li></ul>
E6177A 24-Channel	<ul style="list-style-type: none"><li>• Good for Resistive Loads, Pull-Up, Pull-Down and Bridge</li><li>• Good for Medium Current Applications, Up to 2A</li></ul>

Table 3: Load Card Type and Features

### Measurement Control Module (MCM):

This powerful card contributes to the versatility of the system's capabilities, providing its own 4x16 matrix to fan the four columns into 16 separate instruments. Twelve of these lines are set up in default configuration for the Counter, 2-channel isolated Arbitrary Waveform Generator, Digitizer, and DMM. The MCM card adds other important capabilities to the system as well. For example:

- Connects any pin to any resource
- Four quadrant V/I  $\pm 16V/200mA$ ,  $\pm 100V/20mA$
- Provides isolated programmable voltage or current source with internal wiring for measurement of current or voltage, respectively
- Programmable attenuator allows one-cycle saturation and flyback voltage measurement
- Amplifier amplifies signals from the Waveform Generator to  $\pm 80$  volts; useful when simulating speed sensitive VRS (Variable Reluctance Sensor) signals
- Amplitude-dependent attenuation of incoming signals for digitizing
- Sophisticated, bi-directional trigger routing scheme; 19 trigger inputs may be routed to any of 19 trigger outputs
- Triggers can be routed over VXI backplane to UUT
- Triggers can be routed through timer created pacing, watchdog or trigger delays
- Programmable UUT reference comparator allows the UUT to generate threshold triggers for synchronous instrument measurements

### Mass Interconnect:

The switching interconnects via the mass interconnect to the Unit Under Test [UUT]. The Mass Interconnect consists of an Interface Connect Assembly (ICA) and an Interface Test Adapter (ITA), each having its own connector blocks and matching pins [see Table 4]. To meet test engineers' demand for flexibility the TS-5400 Series II allows you to use the Agilent supplied standard mass interconnect or a user's custom design. The two Agilent supplied mass interconnects are the MAC Panel, and Express Connect. The ICA is mounted to the system rack and both Agilent supplied ICAs feature a hinged insert that, when released, allows the panel to fold down 90° away from the system. This design allows convenient access to the wiring,

Pin Matrix and Load Cards. The ITA inserts into the ICA and locks in place.

Table 4: System Configurations

Key Components of the Express Connect & Mac Panel Interfaces	Optional GPIB & VXI Instrumentation with TS-5400 Series II Action Sets
E1411B Digital Multimeter (DMM)	• E6172A VXI bus-based Pin Matrix
E6171B Measurement Control Module	• E6173A Arbitrary Dual Channel Real Time Arbitrary Waveform Generator • 33220A GPIB 20 MHz Arbitrary Waveform Generator
E6198A 21-Slot Switch/ Load Unit	• E6174A Event Detector
E8792A Pin Matrix Card	• E6181A Digital to Analog Converter
E8793A Pin Matrix Card for added channels; standard on the Express Connect & Mac Panel Interfaces	• E1333A VXI Counter & 53131A GPIB Universal Counter • E1418A 8-Channel Non-isolated Digital to Analog Converter (DAC) • E1563A Dual Channel 800kHz Digitizer

Note: Any GPIB or VXIbus-based instrument may be added to the system

### Software Increases Productivity

Due to its advanced hierarchical software development environment, the TS-5400 Series II delivers maximum reusability. Software is further optimized for fast execution of each routine. This high quality, fully tested software consists of both developer and test-execution environments. The test system developer uses the hierarchical environment for creating the test program. Test Operators view a panel created by the test developer for conducting tests on specific modules. Agilent provides a sample operator interface that's easy to change or upgrade. Developers can also utilize Visual Basic® to quickly develop a custom operator interface.



## More Than Just a Product— It's a Complete Solution

When you choose the Series II, you choose to maximize value with a complete solution offering. The TS-5400 Series II is much more than hardware and software tools. It's a complete system solution—product to services—that includes the following:

- System Documentation
- Application Consulting
- Customer Training
- Software Updates
- Cooperative Maintenance
- Extended Warranties
- Repair, Calibration, and Self Diagnostics
- Remote Support

This wide range of services lets you take advantage of the full value of the TS-5400 Series II.

Documenting a system can be difficult when test engineering's primary focus is to keep production up and running. The TS-5400 Series II provides complete documentation of its unique capabilities: cabling, mass interconnect, power distribution and software. You need only worry about documenting and supporting the customization of the platform. Agilent also offers system platform training to augment its extensive curriculum of educational products. When it comes to hardware components and unique platform features, the Agilent team provides worldwide support. What's more, cooperative support arrangements can be made for optimal uptime of test systems.

## Why Buy the TS-5400 Series II?

Depending on a manufacturer's production situation, there are numerous benefits to adopt the platform concept. Take a look at some of those benefits as they relate to one of your upcoming projects.

### 1. Reduce Test Development Time

Because the TS-5400 Series II is a pre-built system, representing the majority of a test system solution, it's never been easier to keep pace with demand. The software development productivity of the Series II results from a hierarchical approach to test development designed to maximize the reusable code in a structured process. The high quality software environment, tests, measurements, and utilities are a direct result of intensive design, while the unique platform approach saves steps in developing the complete system [see Figure 9]. Moreover, system design and planning steps are reduced as a result of pre-defined architecture. The system interconnections, cabling and racking are specific activities performed by Agilent, while test engineering focuses on the unique aspects of testing a given ECM. In addition, Agilent provides software documentation, training and support.

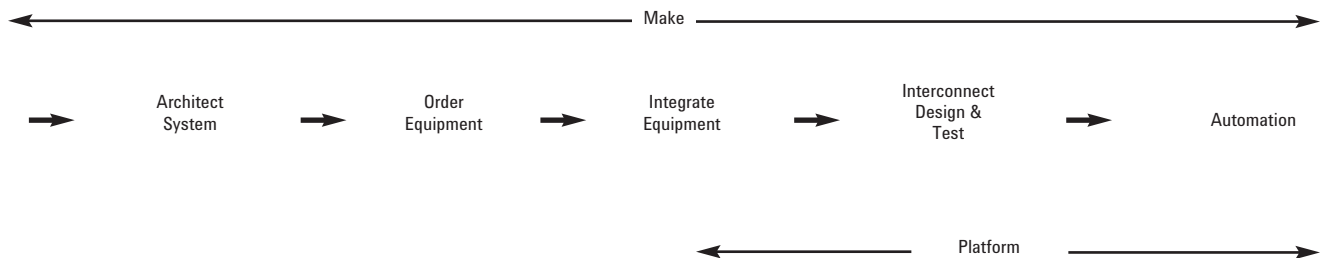

**Figure 9: The TS-5400 Series II Streamlines Test Development Process to Speed Time-to-Market**

## **2. Save Capital Costs**

Running tests faster translates to less equipment and lower costs. The TS-5400 Series II test platform features an instrumentation set that allows Agilent to optimize throughput by tuning the hardware and software for fast execution. With no special effort or time expended, you can use the Agilent software routines for the fastest test times. The unique combination of multiple-up support, for testing more than one UUT at a time, and faster test times will reduce your capital costs.

## **3. Flexibility**

Many manufacturing facilities require flexibility to keep pace with the dynamic changes in the automotive electronics manufacturing industry. New production lines are being deployed worldwide. Technologies are constantly changing, in addition to demands for new ECMs and features. As manufacturing requirements change in this ever-evolving market, it only makes sense that a flexible testing platform approach is better suited to meet your needs. The TS-5400 Series II includes four family members, all built with a common architecture and core. Software and hardware for testing ECMs is available, providing a common look and feel across production lines testing different ECMs. The modularity of the system platform lets you add the functionality you need to test the different versions and types of ECMs, while at the same time controlling automation and line integration.

## **4. Worldwide Deployment**

Many companies are operating in a global business environment. For test departments, this sets the stage for a mixed bag of complications, including setting up new production lines in other countries. Typically, production lines are duplicated and local people are trained to run the manufacturing process. However, there's often a heavy burden imposed on the central test engineering department to support the test stands. Any software changes or questions concerning operation eventually make their way back to these already overburdened engineers.

Software and test systems may be difficult to troubleshoot and maintain, especially when test engineers have time and resource pressures. With the Agilent test platform approach, stable test results are readily achieved worldwide with extensive diagnostics tests that verify system functionality. Furthermore with standardized software, hardware and integration, Agilent Technologies can support the platform worldwide, while support for the integrated solution can be provided locally. Finally, cooperative support between Agilent and the manufacturing site provides maximum uptime.

## **5. Built-in Growth Path**

More often than not, test stands are created in a schedule-driven environment. It's difficult to take the time to design and create a system that can be upgraded and leveraged for an extended period of time. Test plans written on a deployed TS-5400 Series I will run on any of the TS-5400 Series II platforms today and into the future, provided the platform contains the same measurement core. The test plans will execute without changes.

TS-5400 Series II upgrades are most often driven by the need for additional features, measurement capability or more automation. This built-in upgrade path not only preserves your initial investment, it offers the flexibility to grow to a multi-up tester and/or add the latest instruments and computers. In other words, you can start with the TS-5400 Series II configuration that meets your current needs, then upgrade the configuration as production volumes increase or versioning of the ECM requires additional instrumentation. The results? Longer useful life of test systems, as well as a reduction in start-up risks.

## **6. Reduce Total Test Cost**

Test cost is only one factor in reducing the total cost of manufacturing an ECM; however, it's a tangible cost that can be reduced by test engineering. To reduce test costs, test engineers focus on reducing test times, equipment costs and floor space. The TS-5400 Series II answers the call by delivering reduced integration costs, floor space and test times.

With the volume increase in safety, security and convenience modules, manufacturers are looking for ways to meet their line-production rates without building up inventory on the production line. Using the Throughput Multiplier for parallel multiple-up testing of ECMs not only reduces floor space and increases asset utilization, it decreases test times per ECM.

Most electronics manufacturers insist that their biggest test costs are tied directly to the instrumentation hardware. But that may not be the case. Hidden costs of software engineering time, operating costs and maintenance expenses must also be considered in the cost equation. Operation costs include management, facilities, and the skilled personnel needed to run the test systems. With a standard platform of hardware and software, support and training costs are lower than that of a one-of-a-kind system.

## **System Software Reduces Development Time**

The TS-5400 Series II software provides a complete test development and test execution environment for the entire software development job. The test executive environment is tuned for functional testing of electronic devices in manufacturing. The software runs on a PC with Windows NT 4.0 for optimum performance. Plus, it's all pre-installed and ready to use. The TS-5400 Series II software development environment is ideal for creating ECM functional test plans. It consists of re-usable tests, measurements and utilities for performing specific functions related to automotive electronics functional test. Templates and examples are provided to serve as a starting point for creating tests. The Agilent test executive allows you to organize and order tests, reconfigure the test stand, profile the execution speed and debug tests. What's more, the software test execution environment allows an operator to test up to N modules simultaneously (where  $N > 1$ ) and report test information back to the operator. Using the software utilities, the test executive can be easily linked with factory automation, bar code readers and printers.

## **The Agilent TS-5400 Series II Software Development Environment**

The hierarchical test development architecture encourages reuse to decrease development time on upcoming projects. The software provides an efficient and effective structure for developing the test plans and sequencing for functional test of automotive ECMs. In fact, many measurements, tests and utilities are already provided as building blocks. Over 250 routines of the highest quality and provide maximum performance. A test engineering software team need only create the test plan and sequencing from these integral building blocks of software, add customization for the manufacturer's specific ECM serial commands and create any custom test and/or measurements.



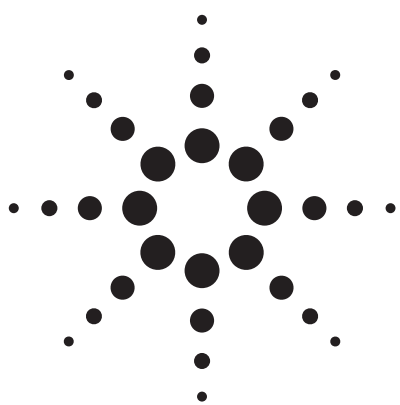

# Agilent TS-5020 Automotive Electronics Functional Test System

## Application Note

### Test Engineering Challenges

On time test deployment within budget requires a test system that provides adequate test coverage and low test times while ensuring the manufacture of quality products. In developing a test platform, you must balance three competing challenges: time (test development, execution and system deployment); cost (capital and integration); and scope (throughput, accuracy and flexibility) [see Figure 1]. In today's automotive electronics manufacturing environment, a reusable, scalable test platform helps meet evolving test requirements and lets you stay competitive.

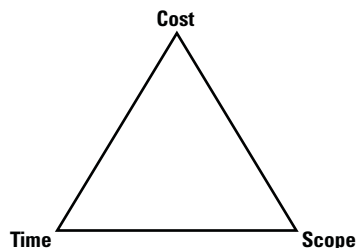

Figure 1: The Balancing Challenge

There are three approaches for you to choose from when creating a test system: use your in-house test department to develop and build your own, outsource the development of an entire system, or use a commercial off-the-shelf platform as the basis for the test system to be deployed.

The Agilent TS-5020 is a new, off-the-shelf test platform tuned specifically for Automotive Electronics Functional Test. With the look and feel of the higher-end Agilent TS-5400 Series II, the TS-5020

addresses the requirement for a lower cost measurement system, catered to a medium pin count range with light duty switching.

### Manufacturing Goals

Producing quality ECMs faster and at a lower cost without compromising test coverage can be a challenge in the fast-paced automotive electronics industry. In exploring the three competing goals of test engineering [see Figure 1] it becomes increasingly clear for the need to focus on each challenge individually, while simultaneously studying how they relate to one another. To meet the pressure in getting manufacturing test lines set up on time requires test engineering to perform faster test development, execution and line integration. In turn, increasing throughput to decrease the test cost per ECM requires faster test system to accommodate the rapid introduction of new convenience, security, safety and body electronic modules.

Achieving the proper balance among all the three goals is difficult yet necessary for manufacturers to better meet OEM timelines. In an effort to find this balance, where time is the ultimate constraint, manufacturers are forced to make decisions on trading test coverage, for maintaining a lean time to market. Either this, or manufacturers are forced to make decisions on trading wide ranging, flexible ECM test capability for module-dedicated test systems – a poor use of assets in the long term. Agilent's new TS-5020 ensures that you do not have

to trade off quality for test systems capability. The Agilent TS-5020 is a platform that allows for flexibility in scope, and maintains a low cost while simultaneously providing you a faster time to market.



Figure 2: Agilent TS-5020 Automotive Electronics Functional Test System



## The Agilent Solution

The TS-5020 Automotive Electronics Functional Test System helps manufacturers get products to market faster by accelerating test system deployment. Engineered with the three critical manufacturing goals in mind, this system caters for flexibility, speed and quality to automotive electronics production.

When it comes to flexibility, a universal test system core of both hardware and software can easily be modified to suit your particular test strategy and range of ECMs. As for speed and quality, the test executive accelerates both the development and execution of tests with over 400 test routines tuned towards automotive applications.

The Agilent TS-5020 is designed to provide performance at a lower cost for applications from simple ECMs such as climate control, immobilizers and RKE (remote-keyless entry), to safety ECMs such as airbag and ABS/TC.

The TS-5020 system comes equipped with measurement hardware, switching, a test executive and automotive tuned library routines. Racking, cabling and optional fixturing are included, as well as standard software development tools that enable test engineers to deploy test systems at a much faster rate than building test systems from individual test systems from individual components.

## Agilent TS-5020 Automotive Electronics Functional Test System

At the heart of Agilent TS-5020 [see Figure 3] is the award winning Agilent 34980A Switch/ Measurement Unit with a built in 6.5 digit multimeter. The system interface uses the Express Connect method. GPIB instruments can be optionally added to enhance the measurement capabilities of the system together with a range of power supplies.

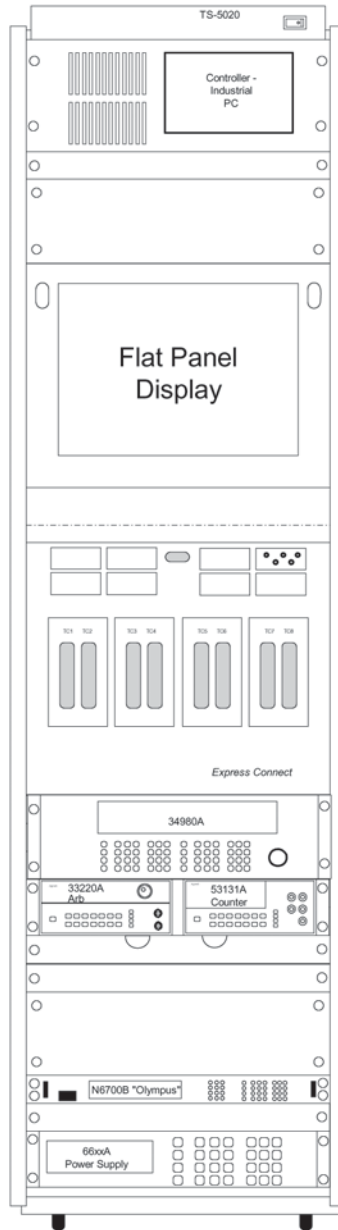

Figure 3: Agilent TS-5020 Automotive Functional Test System

## Key Features

### Measurement Switching

The 34980A provides the switching platform for the TS-5020. To achieve a low cost, low pin count switching, the module supplied with the 34980A is configured as a 16x4x16 (16 instrument x 4 bus x 16 pin) switch matrix. Additional modules can be added and configured as 4x32 to increase the pin channel support up to 112 pins total.

### Measurement

Keeping the TS-5020 a low cost system, the 34980A also offers a built-in DMM complete with independently configurable channels for the measurements you choose. This is a 6 1/2 digits DMM with a .004% of accuracy in DC voltage measurements, complete with channel alarms and math functions.

### Load Switching

With its eight-slot mainframe, the 34980A can be added with a 20 channel "form A" switch to provide light duty load switching enabling it to support 3A continuous current with a 5A peak.

### Mass Interconnect

The switching interconnects to the unit under test (UUT) via the Express Connect interface. This interconnect consists of an interface connect assembly (ICA) and an interface test adapter (ITA), each having its own connector blocks and matching pins. The ICA is mounted to the system rack and feature a hinged insert that when released, allows the panel to fold down 90o away from the system. This design allows convenient access to the wiring. The ITA inserts into the ICA and locks in place.



## Additional Module Options for 34980

### 34933A Dual / Quad 4x8 Reed Matrix Module

Increases the pin count when required.

### 34938A 20 Channel 5A Form A Switch Module

A 20-Channel switch that allows for simple light duty load switching, supporting a 3A continuous current with a 5A peak.

### 3494xA Quad 1 x 4 RF Multiplexer Module

An RF multiplexer that offers bi-directional switching for test signals with high channel isolation. Available in 50 or 75 ohm inputs for 3GHz and 1.5GHz respectively.

### 34945A RF Switch/Attenuator Driver Module for 34980A

A switch/attenuator driver that allows control of switches and attenuators external of the system. The module provides power and control signals for many of the popular microwave switches and attenuators.

## Additional Instrument Options

### 33220A Function / Arbitrary Waveform Generator

The 33220A uses direct digital synthesis techniques to create stable, low-distortion output signals that ensure accurate results. It offers 11 standard waveforms plus pulse and arbitrary waveforms. Custom waveforms can be created using the 14-bit, 50MSa/s, 64K-point arbitrary waveform function. The variable-edge pulse function, along with the PWM, provides excellent flexibility for automotive test applications.

### 53131A Universal Frequency Counter

The two-channel 53131A offers 10 digits per second of frequency or period resolution and bandwidth of 225 MHz. Time interval resolution is specified at 500ps. An optional third channel provides frequency measurements up to 3 GHz, 5GHz, or 12.4GHz. With fast signal processing and automated limit tests, the 53131A can make measurements such as frequency, rise/fall time, phase and more quickly and accurately.

### 66xxA DC Power Supply

This series of 200W linear-regulated DC power supplies is fully programmable via GPIB design to maximize the throughput of UUTs through the manufacturing test process with fast up and down programming time.

### N67xxA Low-Profile Modular Power Supply System

A family of small and flexible modular power supply made of a low-profile, 1U high mainframe that accepts up to 4 modules with each module providing up to 300W of power. Fast command processing makes it ideal for product test environments.

## System Configurations

### Key Components of the TS-5020

34980A Multifunction Switch / Measure Mainframe with built-in DMM  
34933A Dual / Quad 4x8 Reed Matrix Module for 34980A  
E2235A Industrial PC

### Optional Instruments

34933A Dual / Quad 4x8 Reed Matrix Module for 34980A  
34938A 20 Channel 5A Form A Switch Module for 34980A  
34941A Quad 1 x 4 50 ohm 3 GHz RF Multiplexer Module for 34980A  
34942A Quad 1 x 4 75 ohm 1.5 GHz RF Multiplexer Module for 34980A  
34945A RF Switch/Attenuator Driver Module for 34980A  
66xxA DC System Power Supply, 200W  
N67xxA Low-Profile Modular Power Supply System, 50W-300W  
33220A Function / Arbitrary Waveform Generator  
53131A Universal Frequency Counter

## Block Diagrams and Hardware Overview

The architecture of the TS-5020 utilizes a Windows XP Pro-based controller connected to the Agilent 34980A Multifunction Switch/Measure Mainframe with a choice of plug-in modules which include switching, D/A converters and a light load module.

The controller runs Agilent TestExec SL software, a mature test executive with hundreds of pre-tested automotive-tuned library routines.

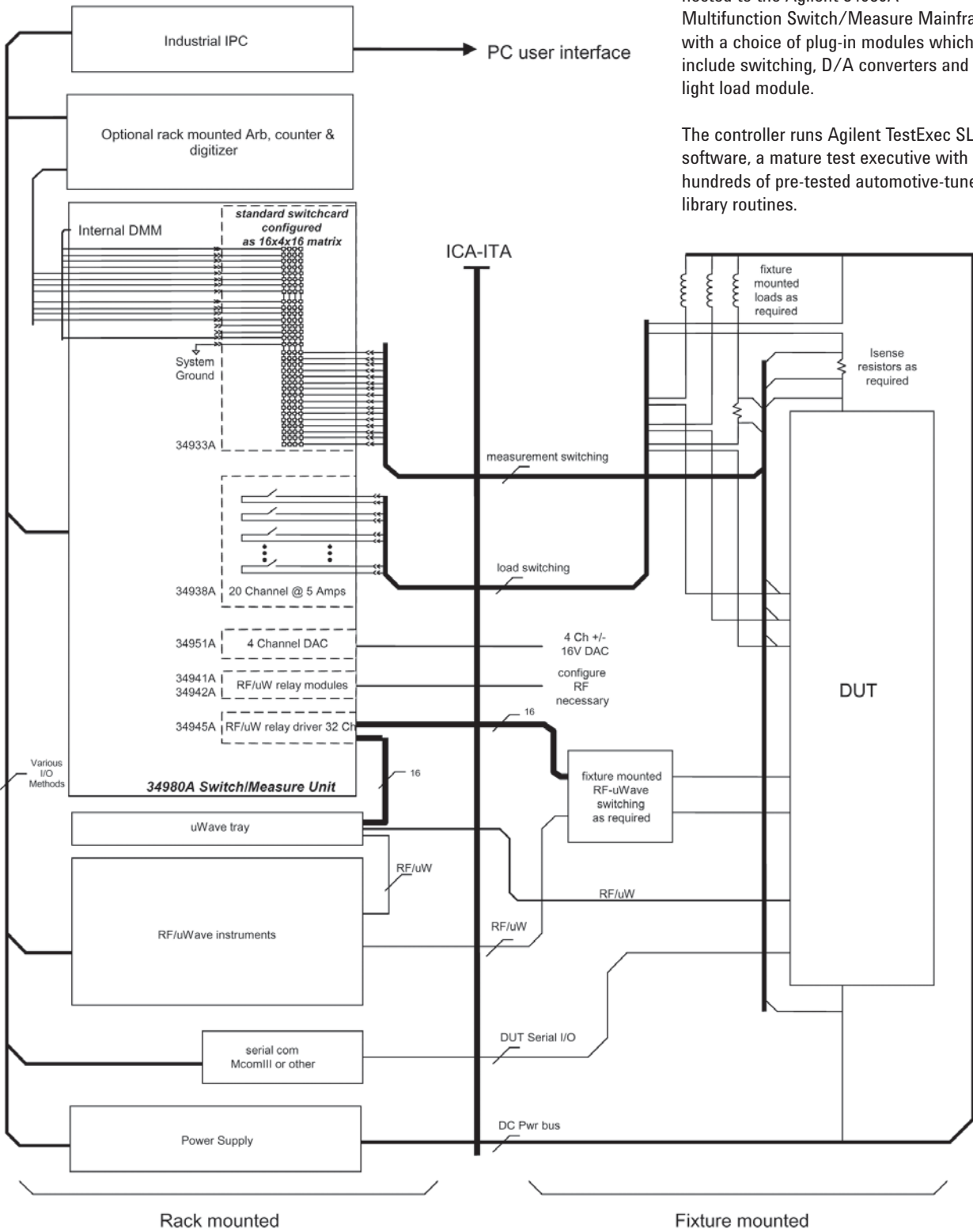

Figure 4: System Block Diagram

## Unique Attributes of Automotive Functional Testing

Functional testing of automotive Electronic Control Modules (ECM) can strain the capabilities of a typical test system. The TS-5020 can address a wide range of ECMs, from climate control to ABS to air bag control. Table 1 takes a closer look at the test requirements for some of these ECMs and the solution Agilent TS-5020 can provide.

## Test Requirements

The advancement of electronically controlled functions in today's automobiles require a wide range of capabilities: fast switching, versatile signal generation and serial communications; to name a few. The TS-5020 is designed to meet these challenges by increasing production volume with higher throughput while reducing the cost of test. As summarized in the table below, the TS-5020 offers a variety of solutions for each of the critical test requirements.

**Table 1: TS-5020 Solutions for Automotive Electronic Control Module Testing**

Test Requirements for ECM	The Agilent TS-5020 Solution
Fast switching for routing of multiple signals and loads	<ul style="list-style-type: none"> <li>• Programmable, easy to use switch path editor</li> <li>• Scalable switching solution to cater up to 112 pins</li> <li>• Load switching support up to 5 A</li> <li>• Maximum of 80 load channels</li> <li>• 42 V-ready solution</li> </ul>
Real-world waveform and signal generation High-current and high-voltage response handling	<ul style="list-style-type: none"> <li>• Variable reluctance and Hall-effect sensor simulation</li> <li>• Flyback voltage and current handling</li> <li>• Voltages up to 150 V, currents up to 5 A</li> <li>• Period, frequency, timing and duration measurement capabilities</li> </ul>
Serial communication	<ul style="list-style-type: none"> <li>• ISO-9141 capability</li> <li>• J1850 capability</li> <li>• J1939 / CAN capability / fault-tolerant CAN /single-wire CAN Controller</li> </ul>

## Test Methodologies

The ability to test many types of modules with one system improves development leverage. Adding test methodologies that accelerate the measurement of each module, regardless of type, is the next step towards lower-cost test.

The Agilent TS-5020 offers two approaches that improve the flexibility and speed of the testing process. One is UUT-assisted testing in which the ECM becomes an active participant in the testing process. The other is the throughput-multiplier strategy which enables batch testing of multiple identical ECMs.

## UUT-Assisted Test

ECM designs include a serial interface. Communication protocols vary by manufacturer, but most comply with OBD2 standards. Variations include ISO-9141, J1939/CAN and J1850. The serial link is used in the automobile itself and can also assist in the testing of the module.

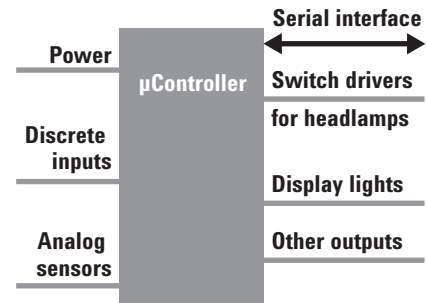

**Figure 5: Example of Serial Interface for an Electronic Control Module (ECM)**

As a programmable device, the ECM can be loaded with either operational code or test code. Operational code is either present in ROM during test or is downloaded when the unit is shipped. Test code is either included in ROM or downloaded through the serial link into the module. By using test code as part of the test program, the TS-5020 establishes a set of conditions to which the ECM responds. This test approach is known as UUT-assisted test.

### Three modes

The TS-5020 enables three different modes for performing UUT-assisted test. The best choice of mode depends on the test stimulus source and response destination.

- Serial Link Evaluation:** This mode simply evaluates the serial link and microcontroller. Commands sent to the microcontroller over the serial link prompt a response that is sent back to the test system. The system then verifies the response and may perform a full CRC memory check. Parametric tests may also be run to test serial link characteristics such as delay, rise or fall time, and input impedance.
- I/O Status Evaluation:** This mode uses the test system I/O to determine ECM input states. It does this by sending a message over the serial link to the ECM prompting it to run a test routine. For example, this mode may be used to apply an analog input to the ECM to verify A/D conversion and the module's handling and communication of data over the serial link. (For example, the analog input may be a simulation of a sensor's output for air temperature.) In this mode, the test system can use UUT-assisted testing to assess proper functioning of several functions at once, including the controller, serial link, A/D and waveform processing circuitry.
- Input Evaluation:** In this mode, the test system supplies an input then reads the value at either the input or output of the module. The evaluation can verify proper receipt of the signal at the module input or if the input cause the appropriate output.

### Throughput multiplier

The throughput multiplier test strategy (multiple-up UUT testing) is one way to increase throughput for a manufacturing environment. Multiple UUT testing not only consolidates tasks common to multiple modules, such as load/unload, instrument setup of signal and load routing, it's also an effective strategy for overlapping inherent latencies in the UUT or test system [shown in Figure 6 and 7]

### Reduce total test cost

Test cost is only one factor in reducing the total cost of manufacturing an ECM. However, it is the tangible cost that can be reduced by test engineering to reduce cost times, equipment costs and floor space. The TS-5020 answers the call by delivering reduced integration costs, floor space and test times.

With the volume increase in safety, security and convenience modules, manufacturers are looking for ways to meet their line-production rate without building up inventory on the production line. Using the throughput multiplier for parallel multiple-up testing of ECMs not only reduces floor space and increases asset utilization, it decreases test times per ECM.

Instrumentation hardware is often believed to be the most significant contributor to test cost, but that may not always be the case. Hidden costs of software engineering time, operating costs and maintenance expenses must also be considered in the cost equation. Operation costs include management, facilities, and the skilled personnel needed to run the test systems. With a standard platform of hardware and software, support and training costs are lower than with a unique, custom-built system.

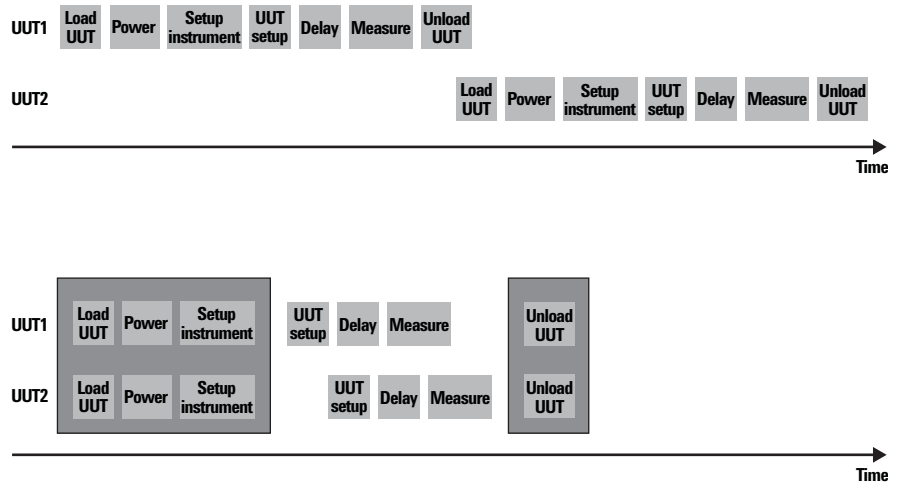

Figure 7: Multi-up testing of two or more UUTs

## System Software Reduces Development time

The TestExec SL software which comes with the TS-5020 provides a complete test development and test execution environment for the entire software development job. The test executive environment is tuned for functional testing of electronic devices in manufacturing. The software runs on a PC with Windows XP Pro for optimum performance, and comes pre-installed and ready to use. The TestExec SL development environment is ideal for creating ECM functional test plans. It consists of re-usable tests, measurements and utilities for performing specific functions related to automotive electronics functional test. Templates and examples are provided to serve as a starting point for creating tests. The Agilent test executive allows you to organize and order tests, reconfigure the test stand, profile the execution speed and debug tests. What's more, the software test execution environment allows an operator to test up to N modules simultaneously (where  $N > 1$ ) and report test information back to the operator. Using the software utilities, the test executive can be easily linked with factory automation, bar code readers and printers.

## The Agilent TestExec SL Software Development Environment

The hierarchical test development architecture encourages reuse to decrease development time on upcoming projects. The software provides an efficient and effective structure for developing the test plans and sequencing for functional test of automotive ECMs. Many measurements, tests and utilities are already provided as building blocks. Over 400 routines tuned towards automotive test provide maximum quality. A test engineering software team needs only create the test plan and sequencing from the integral building blocks of software, add customization for the manufacturer's specific ECM serial commands and create any customer test and/or measurements.

### Find the right solution for your needs

To discuss your requirement in detail, please call your local Agilent office to arrange a consultation. To learn more about the TS-5000 family, visit us on the web at [www.agilent.com/find/ts5020](http://www.agilent.com/find/ts5020). The website also contains information about the full range of Agilent products and services that can help your engineering teams simulate and diagnose system performance in the design stage.

## Individual documents included in the booklet

<b>Publication</b>	<b>Description</b>	<b>Agilent publication number</b>
Using an Agilent 6000 Series MSO to Debug an Automotive CAN Bus	Application note	5989-5049EN
Increase Automotive ECU Test Throughput	Application note	5989-1682EN
Automotive Electronic Functional Test Using Agilent System Components	Application note	5988-3364EN
Testing Antilock Brakes and Traction Control with the Agilent TS-5000 Family of Automotive Electronics Functional Test Systems	Application note	5968-6079E
Testing Remote Keyless Entry Systems with the Agilent TS-5000 Family of Automotive Electronics Functional Test Systems	Application note	5968-6080E
Testing Supplemental Restraint Systems with the Agilent TS-5000 Family of Automotive Electronics Functional Test Systems	Application note	5968-6356E
Using Agilent 6690A Series System DC Power Supplies for Automobile Battery Simulation	Application note	5988-3061EN
Agilent TS-5020 Tire Pressure Monitoring System (TPMS)	Application note	5989-5736EN
Agilent TS-5400 Series II Automotive Electronics Functional Test System	Application note	5968-6784E
Agilent TS-5020 Automotive Electronics Functional Test Systems	Application note	5989-5460EN



## Related Agilent literature

<b>Publication</b>	<b>Description</b>	<b>Agilent publication number</b>
Agilent TS-5000 Family Multi-Channel Loadcards	Data sheet	5989-5822EN
Agilent TS-5400 Developers Training	Technical overview	5980-2185E
Agilent TS-5000 Family – Automotive Electronics Functional Test Systems	Brochure	5989-5857EN
CAN/LIN (N5424A) and FlexRay (N5432A) Options for Automotive Applications Using Agilent's 6000 Series Oscilloscopes	Data sheet	5989-6220EN
Agilent Models 6690A-6692A System DC Power Supply	Data sheet	5988-3149EN
Agilent TS-5410 Functional Test Platform	Technical overview	5989-0233EN
Agilent 6000 Series Oscilloscopes	Data sheet	5989-2000EN

To access these documents online, insert the publication number in the URL:  
<http://cp.literature.agilent.com/litweb/pdf/xxxx-xxxxEN.pdf>



## Agilent Email Updates

[www.agilent.com/find/emailupdates](http://www.agilent.com/find/emailupdates)

Get the latest information on the products and applications you select.



## Agilent Direct

[www.agilent.com/find/quick](http://www.agilent.com/find/quick)

Quickly choose and use your test equipment solutions with confidence.



[www.agilent.com/find/open](http://www.agilent.com/find/open)

Agilent Open simplifies the process of connecting and programming test systems to help engineers design, validate and manufacture electronic products. Agilent offers open connectivity for a broad range of system-ready instruments, open industry software, PC-standard I/O and global support, which are combined to more easily integrate test system development.

## Agilent T&M Software and Connectivity

Agilent's Test and Measurement software and connectivity products, solutions and developer network allows you to take time out of connecting your instruments to your computer with tools based on PC standards, so you can focus on your tasks, not on your connections. Visit [www.agilent.com/find/connectivity](http://www.agilent.com/find/connectivity) for more information.

Microsoft and Microsoft Windows are U.S. registered trademarks of Microsoft Corporation

## Remove all doubt

Our repair and calibration services will get your equipment back to you, performing like new, when promised. You will get full value out of your Agilent equipment throughout its lifetime. Your equipment will be serviced by Agilent-trained technicians using the latest factory calibration procedures, automated repair diagnostics and genuine parts. You will always have the utmost confidence in your measurements.

Agilent offers a wide range of additional expert test and measurement services for your equipment, including initial start-up assistance onsite education and training, as well as design, system integration, and project management.

For more information on repair and calibration services, go to [www.agilent.com/find/removealldoubt](http://www.agilent.com/find/removealldoubt)

## www.agilent.com

For more information on Agilent Technologies' products, applications or services, please contact your local Agilent office. The complete list is available at:

[www.agilent.com/find/contactus](http://www.agilent.com/find/contactus)

### Phone or Fax

#### United States:

(tel) 800 829 4444  
(fax) 800 829 4433

#### Canada:

(tel) 877 894 4414  
(fax) 800 746 4866

#### China:

(tel) 800 810 0189  
(fax) 800 820 2816

#### Europe:

(tel) 31 20 547 2111

#### Japan:

(tel) (81) 426 56 7832  
(fax) (81) 426 56 7840

#### Korea:

(tel) (080) 769 0800  
(fax) (080) 769 0900

#### Latin America:

(tel) (305) 269 7500

#### Taiwan:

(tel) 0800 047 866  
(fax) 0800 286 331

#### Other Asia Pacific Countries:

(tel) (65) 6375 8100  
(fax) (65) 6755 0042  
Email: [tm\\_ap@agilent.com](mailto:tm_ap@agilent.com)

Product specifications and descriptions in this document subject to change without notice.

© Agilent Technologies, Inc. 2007  
Printed in USA, February 7, 2007  
5989-6283EN



Agilent Technologies