



**Advanced Test Equipment Rentals**  
**www.atecorp.com 800-404-ATEC (2832)**

NOTICE: This document contains references to Varian. Please note that Varian, Inc. is now part of Agilent Technologies. For more information, go to [www.agilent.com/chem](http://www.agilent.com/chem).



**VARIAN**   
*vacuum technologies*

# ***Models 947, 948 and 960 Leak Detectors***

*OPERATION AND  
SERVICE MANUAL*

Part No. 699909947  
Revision H  
May 2003

# Models 947, 948 and 960 Leak Detectors



*Contra-Flow, MacroTorr, TriScroll and ConvecTorr are trademarks or registered trademarks of Varian Vacuum Technologies.*

*Apiezon is a registered trademark of M&I Materials Ltd.*

*Alconox is a registered trademark of Alconox, Inc.*

*Loctite and PST are registered trademarks of Loctite Corporation.*

*Scotch-Brite is a trademark of 3M.*

*Skid-Mate is a registered trademark of Hardigg.*

# Table of Contents

<b>Declaration of Conformity</b> .....	<b>xiii</b>
<b>Warranty</b> .....	<b>xiv</b>
Warranty Replacement and Adjustment .....	xiv
<b>Garantie</b> .....	<b>xv</b>
Ersatz und Einstellung unter Garantie .....	xv
<b>Factory Calibration Data</b> .....	<b>xvii</b>
List of Options or Accessories Included with System .....	xvii
Hazard and Safety Information .....	xviii
Solvents .....	xix
Equipment, General .....	xx
Power and Static .....	xxi
Vacuum Equipment and Cleanliness .....	xxii
O-ring Care .....	xxiii
Spectrometer Tube .....	xxiv
Pumps .....	xxiv
Varian Services .....	xxv
Contacting Varian Vacuum Technologies .....	xxv
Informationen über Gefahren und Sicherheit .....	xxvi
Lösungsmittel .....	xxvii
Maschinen, allgemein .....	xxviii
Strom und Statik .....	xxix
Vakuumgeräte und Sauberkeit .....	xxx
Pflege von O-Ringen .....	xxxii
Spektrometerrohr .....	xxxiii
Pumpen .....	xxxiii
Dienstleistungen von Varian .....	xxxiv
Kontaktieren von Varian Vacuum Technologies .....	xxxiv

<b>Section 1. Introduction to Models 947, 948 and 960 Leak Detectors .....</b>	<b>1-1</b>
1.1 Platform Electronics.....	1-4
1.2 Unpacking the 947/948/960.....	1-4
1.2.1 Unpacking Instructions.....	1-4
1.2.2 Removing the 947/948/960 from the Skid.....	1-5
1.2.3 Removing Loose Packing from Interior of 947/948/960.....	1-6
1.3 Front Panel Controls and Indicators .....	1-6
1.4 Inner Door Instruction Label.....	1-9
1.5 Rear Panel Power Connection and Circuit Breakers .....	1-10
1.6 Service Pendant.....	1-11
1.7 Installation Preparation .....	1-12
1.7.1 Power.....	1-12
1.7.2 Liquid Nitrogen (Models 948/960 only) .....	1-13
1.7.3 Oil-Sealed Vacuum Pumps.....	1-13
1.7.4 Special Installation Requirements.....	1-13
1.7.5 Installation Services .....	1-13
1.8 Storage .....	1-14
1.9 Optional Rear Panel Interface Connections.....	1-14
<b>Einführung in die Lecksucher, Modell 947, 948 und 960 .....</b>	<b>15</b>
1.10 Plattformelektronik .....	1-18
1.11 Auspacken der 947/948/960.....	1-18
1.11.6 Anleitungen zum Auspacken .....	1-19
1.11.7 Entfernen der 947/948/960 von der Palette .....	1-19
1.11.8 Entfernen der losen Verpackungsteile aus dem Innenraum der 947/948/960.....	1-20
1.12 Anzeigen und Steuerelemente der Fronttafel .....	1-21
1.13 Anweisungsschild an der Innentür.....	1-24
1.14 Rückseitige Schalttafelstromanschluss und Trennschalter.....	1-25
1.15 Hängebedienungstafel.....	1-26
1.16 Vorbereitung zur Installation .....	1-27
1.16.1 Strom .....	1-27
1.16.2 Flüssigstickstoff (nur Modell 948/960) .....	1-28
1.16.3 Öldichte Vakuumpumpen.....	1-28
1.16.4 Spezielle Anforderungen bei der Installation .....	1-28
1.16.5 Installationsdienste .....	1-29
1.17 Aufbewahrung.....	1-29
1.18 Optionale Anschlüsse an der rückseitigen Schalttafel.....	1-30

<b>Section 2. Leak Detector Integration .....</b>	<b>2-1</b>
2.1 Physical Considerations .....	2-1
2.2 Common Configuration .....	2-1
2.3 Electronic Considerations for the Optional Rear Panel Interface.....	2-9
2.3.1 Discrete I/O J120 Inputs.....	2-9
2.3.2 BCD J121 Outputs .....	2-10
2.3.3 Host Serial Port J123 Pinouts .....	2-11
2.4 Optional Interface Connections.....	2-12
2.4.1 Grounding and Isolation .....	2-12
2.4.2 Setup.....	2-13
2.4.3 Discrete I/O .....	2-13
2.5 Operation using the Optional Rear Panel Interface .....	2-15
2.5.1 Parallel Enable .....	2-15
<b>Section 3. Operation .....</b>	<b>3-1</b>
3.1 Front Panel LED Indicators and Controls .....	3-1
3.2 Initial System Parameter Setup .....	3-3
3.2.1 Parameters and Operating Modes .....	3-3
3.3 Start-Up.....	3-9
3.3.1 Startup Procedure.....	3-10
3.4 Calibration and Sensitivity Checks.....	3-11
3.4.1 Calibration and Sensitivity Checks.....	3-12
3.5 Operating Procedures.....	3-14
3.5.1 Auto Ranging .....	3-14
3.5.2 Manual Ranging.....	3-15
3.6 Standby.....	3-16
3.7 Shutdown .....	3-17
3.8 Using the Pendant for Parameter Setup .....	3-17
3.9 Optional Discrete I/O.....	3-18
<b>Betrieb .....</b>	<b>19</b>
3.10 LED-Anzeigen und Steuerelemente auf der Fronttafel .....	3-20
3.11 Erste Einstellung der Systemparameter .....	3-22
3.11.1 Parameter und Betriebsmod .....	3-22
3.12 Inbetriebnahme.....	3-28
3.12.1 Anleitungen zur Inbetriebnahme .....	3-30
3.13 Kalibrierungs- und Empfindlichkeitsprüfungen.....	3-31
3.13.1 Kalibrierungs- und Empfindlichkeitsprüfungen.....	3-32
3.14 Betriebsverfahren.....	3-34
3.14.1 Automatische Bereichseinstellung .....	3-34
3.14.2 Manuelle Bereichseinstellung .....	3-36
3.15 Bereitschaft .....	3-37
3.16 Abschalten .....	3-37
3.17 Parametereinstellung mit der Hängebedienungstafel .....	3-38
3.18 Optionale diskrete E/A .....	3-39

# Models 947, 948 and 960 Leak Detectors Operations and Service Manual

---

<b>Section 4. Maintenance</b> .....	<b>4-1</b>
4.1 Daily Maintenance .....	4-5
4.1.1 Calibration Check.....	4-5
4.1.1.1 Leak Checking .....	4-5
4.1.1.2 General Suggestions for Leak Checking .....	4-6
4.2 Yearly Maintenance .....	4-7
4.2.1 Replacing the Calibrated Leak.....	4-7
4.2.2 Re-calibrate the Internal Calibrated Leak .....	4-7
4.2.2.1 Removing the Internal Calibrated Leak .....	4-7
4.2.2.2 Replacing the Internal Calibrated Leak .....	4-9
4.2.3 Liquid Nitrogen Cold Trap (Models 948/960 only) .....	4-10
4.2.4 Flüssigstickstoff-Kühlfalle (nur Modelle 948/960) .....	4-11
4.2.5 Spectrometer Tube Overhaul.....	4-12
4.2.5.1 Removal of the Spectrometer Tube and Preamplifier .....	4-13
4.2.5.2 Disassembly of the Spectrometer Tube and Preamplifier .....	4-15
4.2.5.3 Spectrometer Tube Cleaning .....	4-17
4.2.5.4 Reassembly of the Spectrometer Tube and Preamplifier .....	4-17
4.2.5.5 Reinstallation of the Spectrometer Tube .....	4-21
4.2.6 Air Filter.....	4-22
4.2.7 Spectrometer Tube Exchange .....	4-23
4.2.7.1 Removing and Replacing both the Spectrometer Tube Assembly and Preamplifier .....	4-23
4.2.7.2 Reinstalling the Spectrometer Tube .....	4-23
4.2.8 TC1 and TC2 Gauge Replacement and Calibration .....	4-26
4.2.8.1 Replacement of the TC1 Gauge in the Main Valve Block Assembly .....	4-26
4.2.8.2 Replacement of the TC2 Gauge in the Service Block Assembly .....	4-28
4.2.8.3 Thermocouple Gauge Calibration Procedures .....	4-30
4.2.8.4 System Pressure Gauge (TC2) Calibration .....	4-30
4.2.8.4.1 Vacuum (Low Pressure) Calibration .....	4-30
4.2.8.4.2 Atmospheric Calibration .....	4-31
4.2.8.5 Test Port Pressure Gauge (TC1) Calibration .....	4-32
4.2.8.6 Vacuum (Low Pressure) Calibration .....	4-32
4.2.8.7 Atmospheric Calibration .....	4-33
4.2.9 Rough Pump and Forepump Oil Level Check (Oil-sealed Mechanical Pumps) .....	4-34
4.2.9.1 Condition of Oil (Oil-sealed Mechanical Pumps) .....	4-35
4.2.10 Cleaning the Test Port .....	4-35
4.2.10.1 Removing the Test Port .....	4-35
4.2.10.2 Examining and Cleaning the Test Port .....	4-36
4.2.10.3 Replacing the Test Port .....	4-37
4.3 Spare Parts.....	4-37
4.3.10.4 Exchange Assemblies .....	4-37
4.3.10.5 Replacement Parts .....	4-38
4.3.10.6 Ersatz teile .....	4-39

<b>Section 5. Troubleshooting</b> .....	<b>5-1</b>
5.1 Error Condition Codes .....	5-2
5.2 Troubleshooting Symptoms and Solutions .....	5-3
5.3 Fehlerzustandscodes.....	5-5
5.4 Symptome und Lösungen bei der Fehlersuche .....	5-6
<b>Appendix A. Service Pendant Keypad Functions</b> .....	<b>A-1</b>
A.1 Keypad Functions.....	A-1
A.1.1 Using the Service Pendant .....	A-2
A.2 Glossary of Function Keys.....	A-3
A.3 Glossary of Input and Data Keys .....	A-3
<b>Appendix B. Parts Replacement</b> .....	<b>B-1</b>
B.1 Removing the Covers .....	B-1
B.1.1 Opening the Turret .....	B-2
B.1.1.1 Removing the Service Pendant Shelf .....	B-2
B.1.2 Removing the Top Panel .....	B-3
B.1.3 Replacing all Panels and Covers .....	B-4
B.1.3.1 Replacing the Service Pendant Shelf .....	B-4
B.1.3.2 Replacing the Top Panel.....	B-5
B.2 Replacing the Ion Source .....	B-6
B.3 Replacing the Turbo Pump.....	B-9
B.3.1 Turbo Pump .....	B-9
B.3.1.1 Removing the Turbo Pump.....	B-10
B.3.1.2 Replacing the Turbo Pump.....	B-12
B.3.1.2.1 Examining and Cleaning Centering Rings, O-rings and Manifold .....	B-12
B.3.1.2.2 Connecting the Turbo Pump to the SVBA .....	B-13
B.4 Replacing the Rough Pump.....	B-15
B.4.1 Wet Systems .....	B-15
B.4.1.1 Removing the Wet System Rough Pump .....	B-16
B.4.1.1.1 Replacing the Wet System Rough Pump.....	B-17
B.4.1.1.2 Examining and Cleaning Centering Rings, O-rings and Manifold .....	B-17
B.4.1.1.3 Re-installing the Wet System Rough Pump .....	B-18
B.4.2 Dry Systems .....	B-20
B.4.2.1 Removing the Dry System Rough Pump .....	B-20
B.4.2.2 Replacing the Dry System Rough Pump .....	B-21
B.4.2.2.1 Examining and Cleaning Centering Rings, O-rings and Manifold .....	B-21
B.4.2.2.2 Re-installing the Dry System Rough Pump .....	B-21
B.5 Replacing the Forepump .....	B-22
B.5.1 Wet .....	B-22
B.5.1.1 Removing the Wet System Forepump.....	B-23
B.5.1.2 Replacing the Wet System Forepump .....	B-24
B.5.1.2.1 Examining and Cleaning Centering Rings, O-rings and Manifold .....	B-24
B.5.1.2.2 Re-installing the Wet System Forepump .....	B-24

# Models 947, 948 and 960 Leak Detectors Operations and Service Manual

B.5.2 Dry System .....	B-26
B.5.2.1 Removing the Dry System Forepump.....	B-26
B.5.2.1.1 Removing the Isolation Valve from the Forepump.....	B-26
B.5.2.1.2 Removing the Nitrogen Purge Connection from Pump .....	B-27
B.5.2.1.3 Removing the Exhaust Fitting .....	B-27
B.5.2.1.4 Removing the Pump from the Cabinet .....	B-27
B.5.2.2 Replacing the Dry System Forepump.....	B-27
B.5.2.2.1 Examining and Cleaning Centering Rings, O-rings and Manifold..	B-27
B.5.2.2.2 Re-installing the Dry System Forepump .....	B-28
B.5.2.2.3 Connecting the Nitrogen Purge Pump .....	B-28
B.5.2.2.4 Replacing the Isolation Valve .....	B-28
B.5.2.2.5 Replacing the Exhaust Fitting .....	B-29
B.5.2.2.6 Completing Mounting the Pump to the Cabinet Floor .....	B-29
<b>Appendix C. Communications Protocol .....</b>	<b>C-1</b>
C.1 Protocol (RS-232).....	C-1
<b>Appendix D. Inputs and Outputs .....</b>	<b>D-1</b>
D.1 Service Serial Interface (J1).....	D-1
D.2 Optional Rear Panel Interface .....	D-1
D.2.1 Discrete I/O Parallel Interface (J120) .....	D-1
D.2.2 BCD Discrete Output Parallel Interface (J121) .....	D-3
D.2.3 Interface (J122) for Optional Universal Remote Control .....	D-4
D.2.4 Host Serial Port (J123) .....	D-4
<b>Appendix E. 947/948 Specifications .....</b>	<b>E-1</b>
<b>Technische Daten für 947/948 .....</b>	<b>4</b>
<b>Appendix F. Accessories .....</b>	<b>F-1</b>
<b>Appendix G. Leak Detection Theory .....</b>	<b>G-1</b>
G.1 Leak Testing—Why is it Needed?.....	G-1
G.2 Classes of Leak Detection .....	G-1
G.3 Terminology .....	G-2
G.4 Various Methods of Testing for Leaks.....	G-3
G.5 Helium Mass Spectrometer Leak Detection (MSLD) .....	G-4
G.5.1 Principles of Mass Spectrometry .....	G-4
G.5.2 Application as a Leak Detector .....	G-4
G.5.3 The Nature of Flow in a Vacuum .....	G-4
G.5.4 Facts About Leak Rates .....	G-4
G.6 Leak Detection Methods .....	G-5
G.6.1 Test Piece Evacuated .....	G-6
G.6.2 Test Piece Pressurized .....	G-6
G.6.3 Test Piece Already Sealed .....	G-7
G.7 Mass Spectrometer Leak Detector—Simplified Description .....	G-8
<b>Index .....</b>	<b>I-1</b>



# List of Figures

Figure	Description	Page
1-1	947 Leak Detector.....	1-2
1-2	948/960 Leak Detector.....	1-3
1-3	Front Panel Controls and Indicators .....	1-6
1-4	Turret Door Instruction Label .....	1-9
1-5	Rear Power Panel.....	1-10
1-6	Service Pendant.....	1-11
1-7	Rear Panel Interface Connectors.....	1-14
1-8	947 Lecksucher.....	1-16
1-9	948/960 Lecksucher.....	1-17
1-10	Anzeigen und Steuerelemente der Fronttafels .....	1-21
1-11	Anweisungsschild auf Aufsatztür .....	1-24
1-12	Rückseitige Schalttafel.....	1-25
1-13	Hängebedienungstafel .....	1-26
1-14	Schnittstellenanschlüsse an der rückseitigen Schalttafel .....	1-30
2-1	947 Flow Diagram.....	2-2
2-2	947 Ablaufdiagramm.....	2-3
2-3	948 Flow Diagram.....	2-5
2-4	948 Ablaufdiagramm.....	2-6
2-5	960 Flow Diagram.....	2-7
2-6	960 Flow Diagram.....	2-8
2-7	Rear Panel.....	2-12
2-8	Discrete Inputs/Outputs Isolated.....	2-13
3-1	Front Panel LED Indicators and Controls .....	3-1
3-2	Start-Up Controls .....	3-9
3-3	Exponent Display with Condition Code Indicated .....	3-11
3-4	Location of AUTO/MAN MODE Switch .....	3-14
3-5	Service Pendant Keypad .....	3-18
3-6	LED-Anzeigen und Steuerelemente auf der Fronttafel.....	3-20
3-7	Steuerelemente zur Inbetriebnahme.....	3-28
3-8	Exponentenanzeige mit angegebenem Zustandscode.....	3-31
3-9	Position des Schalters AUTO/MAN MODE.....	3-35
3-10	Tastenfeld der Hängebedienungstafel .....	3-38
4-1	Location of the Calibrated Leak .....	4-7
4-2	947/948/960 Spectrometer Tube Removal .....	4-14
4-3	Spectrometer Tube Disassembly.....	4-16
4-4	Spectrometer Tube Reassembly .....	4-18
4-5	Spectrometer Tube Reassembly (Ground Slit Plate).....	4-18
4-6	Spectrometer Tube Reassembly (Magnet Assembly) .....	4-20
4-7	947/948/960 Spectrometer Tube Installation .....	4-21
4-8	Air Filter Replacement .....	4-22

## Models 947, 948 and 960 Leak Detectors Operations and Service Manual

---

4-9	947/948/960 Spectrometer Tube Installation .....	4-24
4-10	TC1 Gauge in the MVBA .....	4-26
4-11	TC2 Gauge in the SBA .....	4-28
4-12	Rough Pump and Forepump Oil Level Check .....	4-34
4-13	The Test Port .....	4-35
4-14	Remove the Test Port Compression Ring and O-ring .....	4-36
4-15	Placing the O-ring and Compression Ring onto the Test Port.....	4-37
A-1	Service Pendant Keypad .....	A-1
B-1	Removing the Service Pendant Shelf .....	B-2
B-2	The Top Panel at the Rear of the Turret.....	B-3
B-3	The Test Port .....	B-3
B-4	The Top Panel from the Front of the 947/948/960.....	B-4
B-5	Ion Source Replacement .....	B-6
B-6	Location of the Turbo Pump .....	B-9
B-7	Turbo Power and Foreline to Turbo Connections .....	B-10
B-8	The Turbo Power Connection.....	B-11
B-9	Radiator Clamp holding Fan to Turbo.....	B-11
B-10	Location of Forepump and Rough Pump — Wet and Dry Configurations .....	B-15
B-11	Rough Pump Manifold and Exhaust Connections .....	B-16
B-12	Rough Pump Manifold and Exhaust Connections .....	B-18
G-1	Test Piece Evacuated: Tracer Probe Used to Locate Leak.....	G-6
G-2	Test Piece Evacuated and Hooded with Helium Atmosphere to Determine Overall Leak Rate .....	G-6
G-3	Test Piece Pressurized: Detector Probe Used to Locate Leak.....	G-6
G-4	Test Piece Sealed with Helium and/or Other Gases – Bell Jar Used to Determine Overall Leak Rate .....	G-7
G-5	Magnetic Separation Principle .....	G-8

## List of Tables

Table	Description	Page
2-1	Valve Operation .....	2-4
2-2	J120 Input Connections .....	2-9
2-3	J121 Output Summary .....	2-10
2-4	J123 Pinout Summary.....	2-11
3-1	<i>NOT READY</i> Condition Codes .....	3-12
3-2	<i>Zustandscodes für nicht betriebsbereites System</i> .....	3-31
4-1	Scheduled Maintenance .....	4-3
4-2	As-Required Maintenance .....	4-4
4-3	Tools and Parts Required for Spectrometer Tube Overhaul.....	4-12
4-4	Exchange Assembly Parts .....	4-38
4-5	Replacement Parts .....	4-38
4-6	Auswechselbare Bauteile.....	4-39
4-7	Ersatzteile .....	4-39
5-1	Error Condition Codes .....	5-2
5-2	Troubleshooting .....	5-3
5-3	Fehlerzustandscodes.....	5-5
5-4	Fehlersuche .....	5-6
C-1	Internal Operating Parameters .....	C-2
C-2	Non-volatile Operating Parameters .....	C-5
C-3	Spectrometer Operating Parameters .....	C-6
C-4	Command Parameters for Leak Detection Actions .....	C-7
D-1	Service Serial Interface (J1) .....	D-1
D-2	Optional Discrete I/O Parallel Interface (J120) .....	D-1
D-3	Optional BCD Discrete Output Parallel Interface (J121) .....	D-3
D-4	Optional Interface (J122) for Optional Universal Remote Control .....	D-4
D-5	Optional Host Serial Port RS-232 Interface (J123) .....	D-4
E-1	947/948/960 Specifications .....	E-1
E-2	947/948/960 Model Types and Part Numbers .....	E-3
E-3	947/948/960 Specifications .....	E-4
E-4	947/948/960 Model Types and Part Numbers .....	E-6
F-1	947/948/960 Accessories .....	F-1
G-1	Decimal Notation .....	G-2

*This page intentionally left blank.*

**Declaration of Conformity**  
**Konformitätserklärung**  
**Déclaration de Conformité**  
**Declaración de Conformidad**  
**Verklaring de Overeenstemming**  
**Dichiarazione di Conformità**  
**We/Wir/Nous/Nosotros/Wij/Noi: Varian, Inc.**

Varian Vacuum Technologies  
121 Hartwell Avenue  
Lexington, MA, 02421-3133 USA



declare under our sole responsibility that the product,  
erklären, in alleniniger Verantwortung, daß dieses Produkt,  
déclarons sous notre seule responsabilité que le produit,  
declaramos, bajo nuestra sola responsabilidad, que el producto,  
verklaren onder onze verantwoordelijkheid, dat het product,  
dichiariamo sotto nostra unica responsabilità, che il prodotto,

**Models 947, 948 and 960 Leak Detectors Operations and Service Manual**

to which this declaration relates is in conformity with the following standard(s) or other normative documents.  
auf das sich diese Erklärung bezieht, mit der/den flogenden Norm(en) oder Richtlinie(n) übereinstimmt.  
auquel se réfère cette déclaration est conforme à la (aux) norme(s) ou au(x) document(s) normatif(s).  
al que se refiere esta declaración es conforme a la(s) norma(s) u otro(s) documento(s) normativo(s).  
waamaar deze verklaring verwijst, aan de volende norm(en) of richtlijn(en) beantwoordt.  
a cui se riferisce questa dichiarazione è conforme alla/e sequente/l norma/o documento/l normativo/i.

**Electromagnetic Compatibility Directive**

89/336/EE

EN55011:1991 Class B

EMC/Limits for Radiated Emissions

EN55022:1995 Class A

EMC/Limits for Conducted Emissions

IEC 1000-4-2/IEC 1000-4-3

EMC/Limits for Electrostatic Emissions

IEC 1000-4-4/IEC 1000-4-6

IEC 801-2 Crit B

EMC/Immunity to Electromagnetic Fields and Transient Bursts

IEC 801-3 Crit A

IEC 801-4 Crit B

Frederick C. Campbell  
Operations Manager  
Varian Vacuum Technologies  
Lexington, Massachusetts, USA



March 2001

## **Warranty**

Products manufactured by Seller are warranted against defects in materials and workmanship for twelve (12) months from date of shipment thereof to Customer, and Seller's liability under valid warranty claims is limited, at the option of Seller, to repair, to replace, or refund of an equitable portion of the purchase price of the Product. Items expendable in normal use are not covered by this warranty. All warranty replacement or repair of parts shall be limited to equipment malfunctions which, in the sole opinion of Seller, are due or traceable to defects in original materials or workmanship. All obligations of Seller under this warranty shall cease in the event of abuse, accident, alteration, misuse, or neglect of the equipment. In-warranty repaired or replaced parts are warranted only for the remaining unexpired portion of the original warranty period applicable to the repaired or replaced parts. After expiration of the applicable warranty period, Customer shall be charged at the then current prices for parts, labor, and transportation.

Reasonable care must be used to avoid hazards. Seller expressly disclaims responsibility for loss or damage caused by use of its Products other than in accordance with proper operating procedures.

Except as stated herein, Seller makes no warranty, express or implied (either in fact or by operation of law), statutory or otherwise; and, except as stated herein, Seller shall have no liability under any warranty, express or implied (either in fact or by operation of law), statutory or otherwise. Statements made by any person, including representatives of Seller, which are inconsistent or in conflict with the terms of this warranty shall not be binding upon Seller unless reduced to writing and approved by an officer of Seller.

## **Warranty Replacement and Adjustment**

All claims under warranty must be made promptly after occurrence of circumstances giving rise thereto, and must be received within the applicable warranty period by Seller or its authorized representative. Such claims should include the Product serial number, the date of shipment, and a full description of the circumstances giving rise to the claim. Before any Products are returned for repair and/or adjustment, written authorization from Seller or its authorized representative for the return and instructions as to how and where these Products should be returned must be obtained. Any Product returned to Seller for examination shall be prepaid via the means of transportation indicated as acceptable by Seller. Seller reserves the right to reject any warranty claim not promptly reported and any warranty claim on any item that has been altered or has been returned by non-acceptable means of transportation. When any Product is returned for examination and inspection, or for any other reason, Customer shall be responsible for all damage resulting from improper packing or handling, and for loss in transit, notwithstanding any defect or non-conformity in the Product. In all cases, Seller has the sole responsibility for determining the cause and nature of failure, and Seller's determination with regard thereto shall be final.

If it is found that Seller's Product has been returned without cause and is still serviceable, Customer will be notified and the Product returned at its expense; in addition, a charge for testing and examination may be made on Products so returned.

3/1/00

# Garantie

Die vom Anbieter hergestellten Produkte sind im Hinblick auf schadhafte Werkstoffe und Verarbeitung für eine Zeitdauer von zwölf (12) Monaten ab Versanddatum derselben an den Kunden garantiert, und die Verpflichtungen des Anbieters im Rahmen gültiger Garantieansprüche ist nach Ermessen des Anbieters auf die Reparatur, den Ersatz oder die Rückerstattung eines angemessenen Teils des Kaufpreises des Produkts beschränkt. Verbrauchsgüter im Normalgebrauch sind von dieser Garantie ausgeschlossen. Der Ersatz oder die Reparatur von Teilen unter Garantie sind auf technische Störungen der Geräte beschränkt, die nach alleinigem Ermessen des Anbieters auf Defekte in den Original-Werkstoffen oder in der Verarbeitung zurückzuführen oder nachweisbar sind. Alle Verpflichtungen des Anbieters im Rahmen dieser Garantie sind im Falle eines Missbrauchs, eines Unfalls, einer Änderung, eines falschen Gebrauchs oder einer Verletzung der Sorgfalt des Geräts nichtig. Unter Garantie reparierte oder ersetzte Teile sind nur für die verbleibende Restzeit der Gültigkeitsdauer der [ursprünglichen Garantie für die reparierten oder ersetzten Teile gewährleistet. Nach Ablauf der jeweiligen Garantiezeit werden dem Kunden dann die aktuellen Preise für Ersatzteile, Arbeitszeit und Transport in Rechnung gestellt.

Die Geräte sind mit angemessener Sorgfalt zu handhaben, um Gefahren zu vermeiden. Der Anbieter lehnt ausdrücklich jegliche Verantwortung für den Verlust oder Schäden ab, die durch die Verwendung seiner Produkte in Abweichung von vorschriftsmäßigen Betriebsverfahren entstanden sind.

Abgesehen von den hier aufgeführten Garantieleistungen gewährt der Anbieter keine gesetzlichen oder anderweitigen Garantien ausdrücklicher oder implizierter Art (in tatsächlicher wie auch in rechtlicher Hinsicht), und abgesehen von den hier aufgeführten Garantieleistungen obliegen dem Anbieter keine Verpflichtungen im Rahmen jeglicher gesetzlichen oder anderweitigen Garantien ausdrücklicher oder implizierter Art (in tatsächlicher wie auch in rechtlicher Hinsicht). Von einer jeglichen Person, einschließlich Vertretern des Anbieters, abgegebene Erklärungen, die nicht mit den Bedingungen dieser Garantie übereinstimmen oder ihnen widersprechen, sind für den Anbieter nicht bindend, solange sie nicht in schriftlicher Form vorliegen und von einem leitenden Angestellten des Anbieters anerkannt wurden.

## Ersatz und Einstellung unter Garantie

Alle Ansprüche im Rahmen der Garantie haben unmittelbar nach Eintreten der Umstände, die Anlass zum jeweiligen Anspruch geben, zu erfolgen und haben innerhalb der gültigen Garantiezeit beim Anbieter oder seinem befugten Vertreter einzugehen. Diese Ansprüche müssen die Seriennummer des Produkts, das Versanddatum sowie eine vollständige Beschreibung der Umstände, die Anlass zum Anspruch geben, enthalten. Vor der Rücksendung jeglicher Produkte zwecks Reparatur und/oder Einstellung ist die Genehmigung des Anbieters oder seines befugten Vertreters für die Rücksendung sowie Anweisungen darüber, auf welche Weise und an welche Adresse diese Produkte zurückzusenden sind, einzuholen. Jegliche zur Prüfung an den Anbieter zurückgesandten Produkte sind auf dem vom Anbieter als annehmbar angegebenen Weg voranzuzahlen. Der Anbieter behält sich das Recht vor, jegliche Garantieansprüche, die nicht umgehend gemeldet wurden, sowie jegliche Garantieansprüche an Produkten, die geändert oder auf unannehmbarem Transportweg zurückgesandt wurden, abzuweisen. Im Falle einer Rücksendung eines Produkts zwecks Prüfung und Inspektion oder aus irgendeinem anderen Grund trägt der Kunde die Verantwortung für Schäden, die auf unsachgemäße Verpackung oder Handhabung entstanden sind, wie auch für Verluste während des Transports, ungeachtet jeglicher Defekte oder Fehlerhaftigkeit des Produktes. In allen Fällen trägt der Anbieter die alleinige Verantwortung bei der Bestimmung der Ursache und Art des Defektes, und die diesbezügliche Entscheidung des Anbieters ist endgültig.

Sollte sich herausstellen, dass das Produkt des Anbieters grundlos zurückgesandt wurde und weiterhin betriebsfähig ist, wird der Kunde diesbezüglich in Kenntnis gesetzt und das Produkt auf seine Kosten zurückgesandt. Darüber hinaus kann bezüglich der auf diese Weise zurückgesandten Produkte eine Gebühr für die Prüfung und Untersuchung derselben erhoben werden.

*This page intentionally left blank.*



## Factory Calibration Data

Model Number: \_\_\_\_\_ Date: \_\_\_\_\_  
Serial Number: \_\_\_\_\_ Initials: \_\_\_\_\_

Your Varian 947/948/960 leak detector has been thoroughly tested prior to shipment. It is shipped tuned to helium on Filament No. 1. Normally, once set, the tuning adjustments are left untouched and calibration may be verified as required.

The data recorded below includes readings taken during the final test prior to shipment. They are convenient for reference purposes if tuning adjustments are altered. Slight changes may occur when using Filament No. 2 or after an ion source is replaced.

Ion Chamber Voltage: \_\_\_\_\_ VDC  
Emission Current: \_\_\_\_\_ mA  
Fixed Focus Voltage: \_\_\_\_\_ VDC  
Repeller Voltage: \_\_\_\_\_ VDC  
Filament Bias Voltage: \_\_\_\_\_ VDC  
Variable Focus Voltage: \_\_\_\_\_ VDC  
Suppressor Voltage: \_\_\_\_\_ VDC  
Offset Index: \_\_\_\_\_  
Gain: \_\_\_\_\_  
Mechanical Pump Model: \_\_\_\_\_ cfm \_\_\_\_\_ VAC \_\_\_\_\_ Hz

### List of Options or Accessories Included with System

_____	_____
_____	_____
_____	_____
_____	_____

## Hazard and Safety Information

This manual uses the following standard safety protocols:

**WARNING**



*The warning messages are for attracting the attention of the operator to a particular procedure or practice which, if not followed correctly, could lead to serious injury.*

**CAUTION**



*The caution messages are displayed before procedures, which if not followed, could cause damage to the equipment.*

**NOTE**



*The notes contain important information.*

Operators and service personnel must be aware of all hazards associated with this equipment. They must know how to recognize hazardous and potentially hazardous conditions, and know how to avoid them. The consequences of unskilled, improper, or careless operation of the equipment can be serious. This product must only be operated and maintained by trained personnel. Every operator or service person must read and thoroughly understand operation/maintenance manuals and any additional information provided by Varian Vacuum Technologies. All warning and cautions should be read carefully and strictly observed. Consult local, state, and national agencies regarding specific requirements and regulations. Address any safety, operation, and/or maintenance questions to your nearest Varian Vacuum Technologies office.

## Solvents

### CAUTION



*The mechanical components of leak detectors are typically cleaned with alcohol, methanol, or other solvents. When heated, sprayed, or exposed to high-temperature equipment, these solvents become flammable and explosive, causing serious injury or death. Do not use these solvents near a high-temperature source. Ventilate the working area with a blower and work in a large, well-ventilated room.*

*Alcohol, methanol, or other solvents are irritants, narcotics, depressants and/or carcinogens. Their inhalation and/or ingestion may produce serious side effects. Prolonged or continued contact with the skin results in absorption through the skin and moderate toxicity. Always ensure that cleaning operations are carried out in large, well-ventilated rooms, and wear eyeshields, gloves, and protective clothing.*

### CAUTION



*Do not clean any aluminum parts with Alconox<sup>®</sup>. Alconox is not compatible with aluminum and will cause damage.*

### NOTE



*During reassembly, always use Loctite<sup>®</sup> PST<sup>®</sup> (teflon-impregnated pipe thread compound) on pipe threads.*

## Equipment, General

### WARNING



*The leak detector is not designed for use with hazardous gases. Verify that the system to be tested has been purged of all hazardous gases prior to using the leak detector. When testing a system that contained hazardous gases, the exhaust of the leak detector should be connected to a scrubbed or toxic containment exhaust. Exposure to hazardous gases could result in serious injury or death.*

### WARNING



*Equipment tightness is guaranteed for normal operating conditions when the equipment leaves the factory. It is the user's responsibility to maintain the level of tightness particularly when pumping dangerous products.*

### CAUTION



*The performance and operating safety of this equipment can be guaranteed only if it is operated according to normal conditions of use.*

### CAUTION



*Always allow at least 4 inches of clearance adjacent to the ventilation holes at the front, back, and bottom of the equipment enclosure.*

### Power and Static

#### WARNING



*Disconnect power from the leak detector before performing any maintenance procedure that requires physically disconnecting any part of the system.*

#### CAUTION



*Many components of the leak detector are static-sensitive devices. Varian Vacuum Technologies recommends that you wear a grounding device when performing any maintenance on the leak detector and especially when performing maintenance of static-sensitive parts.*

#### WARNING



*Electrical insulation must include the appropriate branch circuit (at least 20 A), with long time delay and a reliable earth ground. Do not use an extension cord.*

*Use only the power cord that was provided with your leak detector. The use of extension cords is not recommended and could result in damage to the equipment and loss of warranty.*

*To avoid electric shock, connect the product power cord to a grounded power receptacle. A protective ground connection by way of the grounding conductor in the power cord is essential for safe operation.*

*Before powering up the leak detector for the first time, verify that the leak detector is configured to operate from the local mains supply voltage.*

*Opening the enclosure may expose hazardous voltages. Always disconnect the power cord and any interface cables before opening the enclosure. Do not touch the power inlet's contacts for at least 10 seconds after disconnecting the power cord.*

### CAUTION



*This equipment generates, uses, and can radiate RF energy, and if not installed and used in accordance with the instructional manual, may cause harmful interference to radio communications.*

*When this equipment is operated in a commercial environment, operation is subject to the following conditions:*

- This equipment may not cause harmful interference, and*
- This equipment must accept any interference received, including interference (RF and ESD) that may cause undesired operation.*

*This equipment may need to be reset after RF and/or ESD events by cycling the Power Switch/Circuit Breaker on the back panel of the leak detector.*

*Operation of this equipment in a residential area is likely to cause harmful radio communications interference, in which case the user will be required to correct the interference at his own expense.*

## Vacuum Equipment and Cleanliness

Cleanliness is vital when servicing the leak detector or any vacuum equipment. There are some techniques that are more important in leak detector servicing than in general vacuum work:

### CAUTION



*Do not use silicone oil or silicone grease.*

*Use powder-free butyl or polycarbonate gloves to prevent skin oils from getting on vacuum surfaces.*

*Do not clean any aluminum parts with Alconox<sup>®</sup>. Alconox is not compatible with aluminum and will cause damage.*

### NOTE



*Normally, it is unnecessary to use vacuum grease. However, if it must be used, avoid silicone types, and use it sparingly. Apiezon<sup>®</sup> L grease (Varian Vacuum Technologies Part No. 695400004) is recommended.*

### O-ring Care

When removing, checking, or replacing O-rings, keep in mind the following:



*Varian Vacuum Technologies recommends replacing all O-rings during routine maintenance or during any maintenance procedure requiring that O-rings be removed.*



*Remove O-rings carefully with your fingers. Do not use metal tools for this task. Follow these guidelines to prevent scratching of any sealing surfaces:*

- Wipe all O-rings clean with a lint-free cloth before installation to ensure that no foreign matter is present to impair the seal.*
- Do not use grease or use other substances on O-rings that will come in contact with the spectrometer tube.*
- Do not use alcohol, methanol, or other solvents on O-rings. To do so causes deterioration and reduces the O-ring's ability to hold a vacuum.*
- In allowable situations, apply a small amount of Apiezon L grease and wipe the O-rings "shiny" dry.*



*VacuSolv, included in the Component and Spectrometer Tube Cleaning Kit (Part No. 670029096), is recommended for cleaning the spectrometer tube components.*

*VacuSolv can also be used for fine cleaning of other parts in the leak detector's vacuum system, such as valves and fittings. No rinsing steps or high-temperature drying is required following cleaning with VacuSolv. Although appropriate precautions are advised, VacuSolv is compatible with most materials and does not contain toxic chemicals or CFCs (chlorofluorocarbons).*

## Spectrometer Tube

**CAUTION**



*The spectrometer tube operates at a very high vacuum produced by the high vacuum pump. Service of the spectrometer tube requires that this vacuum be vented to the atmosphere.*

**CAUTION**



*Do not use grease or other substance on O-rings that will come in contact with the spectrometer tube.*

**CAUTION**



*If the spectrometer tube magnet comes in contact with a magnetic surface, the magnet may lose its field strength, causing the spectrometer tube to lose sensitivity.*

**WARNING**



*Store the ion source in a cool, dry area in a tightly sealed container. Wash hands thoroughly after handling the ion source, especially before smoking or eating.*

## Pumps

**WARNING**



*To avoid injury, use proper lifting techniques when moving pumps. Your system may have pumps that require two people to move them safely.*

**WARNING**



*The vacuum pumps are also compressors; incorrect operation may be dangerous. Study the "Installation and Operation Manual" enclosed with your pump before starting pumps.*



### Varian Services

The following are just a few of the many services that Varian offers its customers. Please see our catalog, or contact us to learn of the services that are available. Contact Varian Vacuum Technologies Customer Service at 1-800-8VARIAN for details.

- Rebuilt spectrometer tubes are available on an exchange basis.
- NIST-traceable calibrated leak testing and verification services.

### Contacting Varian Vacuum Technologies

In the United States, you can contact Varian Vacuum Technologies Customer Service at 1-800-8VARIAN.

Internet users:

- Send email to Customer Service & Technical Support at [vpl.customer.support@varianinc.com](mailto:vpl.customer.support@varianinc.com)
- Visit our web site at [www.varianinc.com/vacuum](http://www.varianinc.com/vacuum)
- Order on line at [www.evarian.com](http://www.evarian.com)

See the back cover of this manual for a listing of our sales and service offices.

## Informationen über Gefahren und Sicherheit

In diesem Handbuch werden die folgenden standardgemäßen Sicherheitsprotokolle verwendet:

### WARNUNG



*Warnhinweise dienen dazu, die Aufmerksamkeit des Bedieners auf bestimmte Verfahren oder Vorgehensweisen zu lenken, die, wenn sie nicht vorschriftsmäßig befolgt werden, zu schwerwiegenden Verletzungen führen könnten.*

### VORSICHT



*Hinweise zur Vorsicht werden vor Verfahren angezeigt, die, wenn sie nicht befolgt werden, zu Maschinenschäden führen können.*

### HINWEIS



*Hinweise enthalten wichtige Informationen.*

Bedienungs- und Wartungspersonal muss alle Gefahren im Zusammenhang mit dieser Maschine kennen. Es muss wissen, wie gefährliche und potenziell gefährliche Bedingungen erkannt werden und wie sie vermieden werden können. Eine unwissende, unsachgemäße oder fahrlässige Bedienung der Maschine kann schwerwiegende Folgen haben. Dieses Produkt ist ausschließlich von ausgebildetem Personal zu bedienen und zu warten. Mit der Bedienung und Wartung beauftragte Personen müssen die Betriebs- und Wartungshandbücher sowie alle von Varian Vacuum Technologies bereitgestellten zusätzlichen Informationen gelesen und in allen Einzelheiten verstanden haben. Alle Warnungen und Hinweise zur Vorsicht müssen sorgfältig gelesen und streng eingehalten werden. In Bezug auf spezifische Anforderungen und Vorschriften setzen Sie sich bitte mit den jeweiligen lokalen, bundes- und landesweiten Behörden in Verbindung. Fragen bezüglich Sicherheit, Betrieb und/oder Wartung sind an Ihren nächsten Varian Vacuum Technologies Händler zu richten.

## Lösungsmittel

### VORSICHT



*Die mechanischen Komponenten des Lecksuchers werden in der Regel mit Alkohol, Methanol oder anderen Lösungsmitteln gereinigt. Werden diese Komponenten erwärmt, besprüht oder Hochtemperaturgeräten ausgesetzt, entwickeln diese Lösungsmittel entzündbare und explosive Eigenschaften und können somit schwerwiegende Verletzungen mit möglicher Todesfolge verursachen. Diese Lösungsmittel dürfen nicht in Nähe von Hochtemperaturquellen verwendet werden. Entlüften Sie den Arbeitsbereich mit einem Gebläse und arbeiten Sie in einem großen, gut entlüfteten Raum.*

*Alkohol, Methanol und andere Lösungsmittel sind Reiz-, Betäubungs- oder Beruhigungsmittel und/oder karzinogen. Die Inhalation und/oder Ingestion dieser Substanzen kann schwerwiegende Nebenwirkungen auslösen. Eine anhaltende oder fortlaufende Berührung mit der Haut führt zu einer Absorption durch die Haut und mäßiger Toxizität. Sorgen Sie immer dafür, dass Reinigungsarbeiten in großen, gut entlüfteten Räumen durchgeführt werden, und tragen Sie Schutzbrille, Handschuhe sowie Schutzbekleidung.*

### VORSICHT



*Aluminiumteile dürfen nicht mit Alconox<sup>®</sup> gereinigt werden. Alconox ist nicht geeignet für Aluminium und verursacht Schäden.*

### HINWEIS



*Benutzen Sie beim Wiedereinbau immer Loctite<sup>®</sup> PST<sup>®</sup> (mit Teflon imprägnierte Rohrgewindemasse) an Rohrgewinden.*

## Maschinen, allgemein

### WARNUNG



*Der Lecksucher eignet sich nicht für eine Verwendung mit gefährlichen Gasen. Vergewissern Sie sich, dass alle gefährlichen Gase vom System abgelassen wurden, bevor Sie den Lecksucher benutzen. Bei der Prüfung eines Systems, das gefährliche Gase enthalten hat, muss der Ablass des Lecksuchers an einen gewaschenen Ablass oder einen Eindämmungsablass für toxische Stoffe angeschlossen werden. Eine Aussetzung gegenüber toxischen Gasen kann zu schwerwiegenden Verletzungen mit möglicher Todesfolge führen.*

### WARNUNG



*Wenn die Maschine das Werk verlässt, ist ihre Dichtigkeit für normale Betriebsbedingungen garantiert. Es obliegt der Verantwortung des Benutzers, die Dichtigkeit der Maschine insbesondere beim Pumpen gefährlicher Produkte zu wahren.*

### VORSICHT



*Die Leistung und Betriebssicherheit dieser Maschine kann nur dann gewährleistet werden, wenn sie in Übereinstimmung mit den normalen Einsatzbedingungen benutzt wird.*

### VORSICHT



*Sorgen Sie dafür, dass an den Ablassöffnungen an der Vorder- und Rückseite wie auch am unteren Rand des Maschinengehäuses immer ein Freiraum von mindestens 10 cm gewahrt wird*

### Strom und Statik

#### WARNUNG



*Trennen Sie den Lecksucher von der Netzstromversorgung, bevor Sie jegliche Wartungsverfahren durchführen, die eine physikalische Trennung eines beliebigen Systemteils erfordert.*

#### VORSICHT



*Viele Komponenten des Lecksuchers sind statisch geladen. Varian Vacuum Technologies empfiehlt, dass Sie bei der Durchführung von Wartungsarbeiten am Lecksucher und insbesondere bei Wartungsarbeiten an statisch geladenen Teilen ein Erdungsgerät tragen.*

#### WARNUNG



*Zur elektrischen Isolierung muss die entsprechende Abzweigung (mindestens 20 Amp) mit langer Verzögerungszeit und einer betriebssicheren Erde gehören. Das Kabel darf nicht verlängert werden.*

*Benutzen Sie nur das Netzkabel, das mit Ihrem Lecksucher geliefert wurde. Die Verwendung von Verlängerungskabeln wird nicht empfohlen und kann zu einer Beschädigung der Maschine wie auch einem Garantieverlust führen.*

*Um einen Stromschlag zu vermeiden, muss das Netzkabel des Produkts an eine geerdete Steckdose angeschlossen werden. Eine Schutzerdung in Form eines Erdungssteckverbinders im Netzkabel ist für den sicheren Betrieb der Maschine unerlässlich.*

*Verifizieren Sie vor der erstmaligen Inbetriebnahme des Lecksuchers, dass er für einen Betrieb über die lokale Netzspannung konfiguriert ist.*

*Durch Öffnen des Gehäuses können gefährliche Voltspannungen freigesetzt werden. Trennen Sie vor Öffnen des Gehäuses immer das Netzkabel und alle Verbindungskabel. Vermeiden Sie nach Trennen des Netzkabels mindestens 10 Sekunden lang, mit den Stromeingangskontakten in Berührung zu kommen.*

### VORSICHT



*Diese Maschine generiert, benutzt und gibt u.U. Hochfrequenzenergie ab und kann, wenn sie nicht in Übereinstimmung mit den im Handbuch enthaltenen Anleitungen installiert und benutzt wird, schädliche Störungen des Funkverkehrs verursachen.*

*Bei einer Benutzung dieser Maschine in kommerziellen Umgebungen unterliegt der Betrieb folgenden Bedingungen:*

- Diese Maschine generiert u.U. keine schädlichen Störungen und*
- Diese Maschine muss alle empfangenen Störungen aufnehmen, einschließlich Störungen (Hochfrequenz und elektrostatische Entladung), die einen unerwünschten Betrieb herbeiführen könnten.*

*Diese Maschine muss nach aufgetretenen Hochfrequenz- oder ESD-Ereignissen durch eine wiederholte Betätigung des Netzschalters bzw. Trennschalters an der Rückseite des Lecksuchers evtl. zurückgesetzt werden.*

*Die Benutzung dieser Maschine in Wohngebieten verursacht wahrscheinlich schädliche Störungen des Funkverkehrs, die der Benutzer auf eigene Kosten zu beheben verpflichtet ist.*

### Vakuumgeräte und Sauberkeit

Bei der Wartung von Lecksuchern oder Vakuumgeräten jeglicher Art ist Sauberkeit von größter Bedeutung. Einige Vorgehensweisen spielen bei der Wartung von Lecksuchern eine größere Rolle als bei allgemeinen Arbeiten an Vakuumgeräten.

#### VORSICHT



*Benutzen Sie kein Öl oder Schmiermittel auf Silikonbasis.*

*Benutzen Sie ungepuderte Butyl- oder Polykarbonat-Handschuhe, um zu verhindern, dass Hautöle auf Vakuumflächen geraten.*

*Aluminiumteile dürfen nicht mit Alconox® gereinigt werden. Alconox ist nicht geeignet für Aluminium und verursacht Schäden.*

#### HINWEIS



*Es ist in der Regel nicht erforderlich, Vakuumschmiermittel zu verwenden. Sollte ihre Verwendung jedoch unumgänglich sein, vermeiden Sie Schmiermittel auf Silikonbasis und tragen Sie es sparsam auf. Das Schmiermittel Apiezon® L (Varian Vacuum Technologies Prod.-Nr. 695400004) wird empfohlen.*

## Pflege von O-Ringen

Beim Entfernen, Prüfen oder Auswechseln von O-Ringen ist Folgendes zu beachten:

### HINWEIS



*Varian Vacuum Technologies empfiehlt, im Rahmen routinemäßiger Wartungsarbeiten oder Verfahrensweisen, die das Entfernen von O-Ringen erfordern, alle O-Ringe zu ersetzen.*

### VORSICHT



*Entfernen Sie O-Ringe vorsichtig mit Ihren Fingern. Benutzen Sie hierzu keine Metallwerkzeuge. Befolgen Sie diese Anleitungen, um zu verhindern, dass die Dichtflächen in irgendeiner Weise verkratzt werden.*

- Wischen Sie vor der Installation mit einem faserfreien Tuch über alle O-Ringe, um sicherzustellen, dass keine Fremdkörper vorhanden sind, welche die Dichtung beeinträchtigen könnten.*
- Benutzen Sie kein Schmiermittel oder andere Substanzen auf O-Ringen, die mit dem Spektrometerrohr in Berührung kommen.*
- Benutzen Sie auf O-Ringen kein Alkohol, Methanol oder andere Lösungsmittel. Dies beeinträchtigt die Dichtleistung und die Fähigkeit des O-Rings, ein Vakuum zu wahren.*
- Tragen Sie in zulässigen Situationen eine kleine Menge Apiezon L auf und reiben Sie die O-Ringe trocken, bis sie glänzen.*

### HINWEIS



*VacuSolv, Bestandteil des Reinigungssatzes für Komponenten und Spektrometerrohre (Prod Nr. 670029096), wird zur Reinigung von Spektrometerrohr-Komponenten empfohlen.*

*VacuSolv eignet sich zur Feinreinigung anderer Teile im Vakuumsystem des Lecksuchers, wie z.B. Ventile und Fittings. Im Anschluss an eine Reinigung mit VacuSolv ist kein Durchspülen oder Hochtemperatur-Trocknen erforderlich. Obwohl angemessene Vorkehrungen ratsam sind, ist VacuSolv mit den meisten Materialien kompatibel und enthält keine toxischen Chemikalien oder FCKW (Fluorchlorkohlenwasserstoff).*



## Spektrometerrohr

**VORSICHT**



*Das Spektrometerrohr wird mit einem sehr hohen Vakuum betrieben, das von der Hochvakuumpumpe generiert wird. Bei der Wartung des Spektrometerrohrs ist eine Ableitung dieses Vakuums ins Freie erforderlich.*

**VORSICHT**



*Benutzen Sie kein Schmiermittel oder andere Substanzen auf O-Ringen, die mit dem Spektrometerrohr in Berührung kommen.*

**VORSICHT**



*Wenn der Magnet des Spektrometerrohrs mit einer magnetischen Fläche in Berührung kommt, verliert der Magnet evtl. seine Feldstärke und das Spektrometerrohr somit seine Empfindlichkeit.*

**WARNUNG**



*Wahren Sie die Ionenquelle an einem kühlen, trockenen Ort in einem dicht verschlossenen Behälter auf. Waschen Sie sich nach der Handhabung der Ionenquelle gründlich Ihre Hände, insbesondere bevor Sie rauchen oder essen.*

## Pumpen

**WARNUNG**



*Befolgen Sie beim Bewegen von Pumpen angemessene Hubverfahren, um Verletzungen zu vermeiden. Es ist möglich, dass Ihr System zwei Pumpen enthält, die nur von zwei Personen sicher bewegt werden können.*

**WARNUNG**



*Die Vakuumpumpen sind auch Kompressoren; ihr unsachgemäßer Betrieb kann gefährlich sein. Lesen Sie vor dem Einschalten Ihrer Pumpen das mit Ihrer Pumpe gelieferte "Installations- und Betriebshandbuch".*

## **Dienstleistungen von Varian**

Im Folgenden werden nur einige der umfassenden Dienstleistungen aufgeführt, die Varian seinen Kunden zu bieten hat. Um Näheres über die verfügbaren Dienstleistungen zu erfahren, nehmen Sie bitte auf unseren Katalog Bezug oder setzen Sie sich mit uns in Verbindung. Sie erreichen den Kundendienst von Varian Vacuum Technologies unter der Nummer 1-800-8VARIAN.

- Erneuerte Spektrometerrohre sind auf Austauschbasis erhältlich.
- NIST-nachweisbare, kalibrierte Leckprüf- und Verifizierungsdienste.

## **Kontaktieren von Varian Vacuum Technologies**

Für weitere Informationen zu diesem Thema wenden Sie sich bitte an Ihren nächsten Varian-Händler. Angaben dazu befinden sich auf der letzten Seite dieses Handbuchs.

Internetbenutzer:

- Senden Sie ein E-Mail an Kundendienst & Technische Unterstützung an folgende Adresse: [vpl.customer.support@varianinc.com](mailto:vpl.customer.support@varianinc.com)
- Besuchen Sie unsere Website [www.varianinc.com/vacuum](http://www.varianinc.com/vacuum)
- Bestellen Sie online bei [www.evarian.com](http://www.evarian.com)

Eine Liste unserer Vertriebs- und Kundendienststellen befindet sich auf der Rückseite dieses Handbuchs.

## Section 1. Introduction to Models 947, 948 and 960 Leak Detectors

Varian Vacuum Technologies' Model 947, Model 948 and Model 960 are Platform Auto-Test® Helium Mass Spectrometer Leak Detectors. In this manual, these leak detectors are referred to as Models 947/948/960.

This manual provides you with:

- ❑ Equipment descriptions
- ❑ Complete operating instructions, including control and indicator descriptions, maintenance, calibration, and interfacing procedures
- ❑ Troubleshooting information

Conformity, Warranty and Safety information is listed at the start of this book. This information should be read before operating the equipment.

The 947/948/960 has rugged metal enclosures that are mounted on casters for greater mobility. A key is used to access the lockable turret that houses the service pendant.

The 947/948/960 has the following basic components:

- ❑ Mechanical backing pump
- ❑ Mechanical roughing pump
- ❑ Spectrometer tube
- ❑ Contra-Flow™ Vacuum system (960 uses conventional flow)
- ❑ Platform electronics
- ❑ Front panel and indicators

The 947/948/960 can be configured with dry or wet pumps. The 948/960 have a nitrogen cold trap.

The platform electronics, service pendant, and displays are located in the turret. Leak rate and system status information is displayed on the front panel, and is also available through the rear panel I/O.

## Models 947, 948 and 960 Leak Detectors Operations and Service Manual

---

The Model 947 is shown in Figure 1-1. Descriptions of the turret and operational buttons identified in Figure 1-1 follow the figure. Models 948/960 are shown in Figure 1-2.

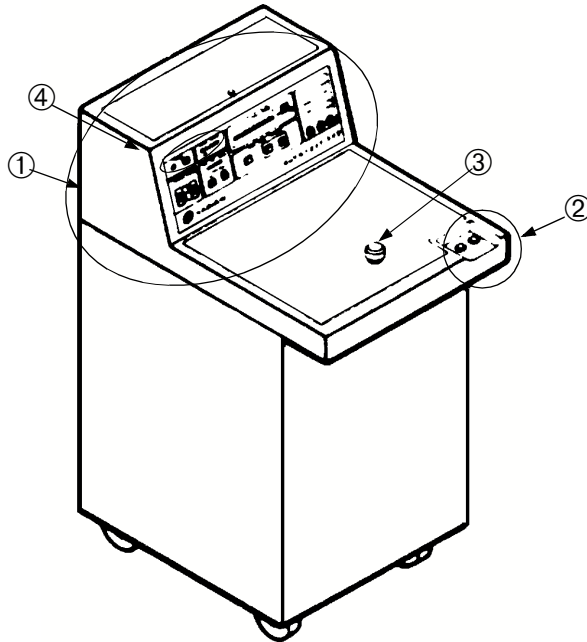

**Figure 1-1 947 Leak Detector**

- |                       |   |
|-----------------------|---|
| ① Turret              | Enclosure for Service Pendant and electronics |
| ② Operational buttons | Start and Vent buttons                        |
| ③ Test Port           | Attachment                                    |
| ④ Standard Leak label | Label with internal standard leak value       |

## Models 947, 948 and 960 Leak Detectors Operations and Service Manual

---

Models 948/960 are shown in Figure 1-2. The door on the working surface of the 948/960 provides access to the nitrogen cold trap. Descriptions of the turret, operational buttons, and nitrogen trap identified in Figure 1-2 follow the figure.

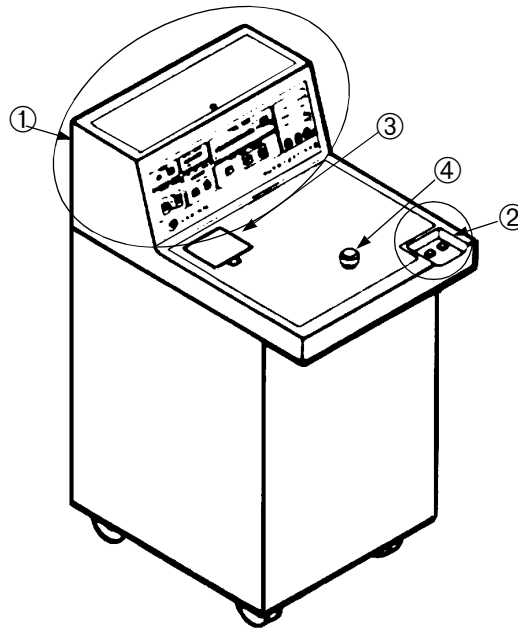

**Figure 1-2 948/960 Leak Detector**

① Turret	Enclosure for Service Pendant and electronics
② Operational buttons	Start and Vent buttons
③ Liquid nitrogen trap	Access to Liquid nitrogen trap
④ Test port	Attachment

### 1.1 Platform Electronics

The 947/948/960 use Varian Vacuum Technologies' Platform leak detector electronics architecture to:

- Operate the spectrometer assembly
- Control the mechanical and high vacuum pumps
- Control the valves
- Provide leak rate and system status information to the operator interface and rear I/O

An advanced electronics platform provides complete diagnostic information and allows adjustments without testpoints or potentiometers. The platform is a collection of printed circuit boards that operate using the PC/104 Bus Structure to perform the various functions of a helium mass spectrometer leak detector. The microprocessor also stores key tuning parameters and retains them in EPROM. This provides for fast recovery after a momentary loss of line voltage.

### 1.2 Unpacking the 947/948/960

When receiving the 947/948/960, the following pieces are included:

- Models 947/948/960 leak detector
- Service Pendant
- Power cable (115 VAC or 230 VAC)
- Pump manuals (for the purchased configuration)

Refer to the *Unpacking Instructions* located on the outside of the shipping container before opening the container. The 947/948/960 are carefully packed onto a shock absorbing skid and enclosed by a heavy cardboard container banded to the skid. The factory packing provides maximum protection during shipment.

#### 1.2.1 Unpacking Instructions

To unpack the 947/948/960 and remove it from the skid:

1. Inspect the container for evidence of damage in shipment.
  - a. Do not discard any evidence of rough handling.
  - b. Report any damage to the carrier and Varian Vacuum Technologies Customer Service at 1-800-8VARIAN without delay.
2. Carefully remove the outer shipping container.

3. Inspect the leak detector and related items immediately for any indication of shipping damage.
4. Carefully cut the strapping holding the leak detector on the skid.
5. Remove any loose boxes or packages and put them aside. Keep the original packing for re-use in the event that it is necessary to return the leak detector to Varian Vacuum Technologies.
6. Carefully remove the front brace by removing the two lag bolts.
7. Carefully remove the plastic bag covering the leak detector.

The leak detector can now be removed from the skid.

### 1.2.2 Removing the 947/948/960 from the Skid

There are two methods for removing the 947/948/960 from the skid. Both methods require two people. The second method involves removing the Skid-Mates from the skid.

#### WARNING



*Handle the leak detector carefully and properly in the following steps. Personal injury or damage to the leak detector could result from improper handling. The 947/948/960 is heavy and can cause personal injury if not handled carefully when removing it from the skid.*

#### Method 1

1. With the assistance of a helper, carefully roll the leak detector toward the front of the skid.
2. Lift the front end of the unit and *gently* lower it onto the floor.
3. Lift the rear of the unit and roll it on the front casters until it is clear of the skid.
4. *Gently* lower the rear end onto the floor.

#### Method 2

1. Using the brace removed in step 6 of Section 1.2.1, "Unpacking Instructions" as a lever, carefully raise the front edge of the skid between 1" and 2".
2. While a helper holds the leak detector against the back brace, unscrew and remove the front two *Skid-Mates* (the blue donut-shaped mounts at the front of the skid) by turning them in a counterclockwise direction.
3. Make sure the helper is still holding the leak detector against the back of the skid, then gently lower the front of the skid to the floor.
4. Carefully and slowly roll the leak detector off the skid and onto the floor.

## 1.2.3 Removing Loose Packing from Interior of 947/948/960

Once the 947/948/960 is off the skid, the loose packing inside the enclosure must be removed.

1. Open the front panel of the 947/948/960, which is the main access to service the pumps and the spectrometer tube.
2. Take out and remove all loose packing from inside the leak detector.

## 1.3 Front Panel Controls and Indicators

The front panel controls and indicators are identified by number in Figure 1-3. Descriptions of each numbered item follow Figure 1-3.

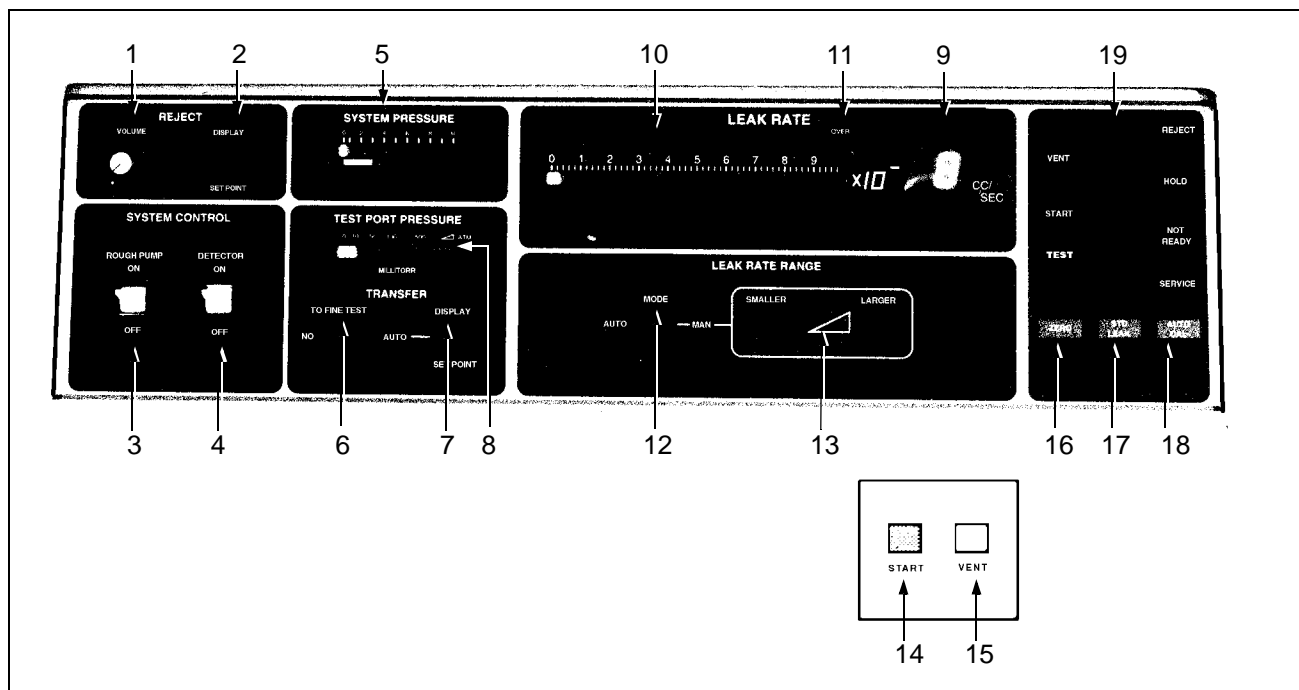

Figure 1-3 Front Panel Controls and Indicators



## Models 947, 948 and 960 Leak Detectors Operations and Service Manual

---

1	Volume Control	Controls the volume of the audible leak rate signal.
2	Display Button	Displays the selected reject level of the leak detector using the 50-segment leak rate bar graph and the appropriate range exponent.
3	Rough Pump Power Switch	Controls the power to the roughing pump.
4	Detector Power Switch	Controls the power to the backing pump and high vacuum pump.
5	System Pressure Bar Graph	Displays system pressure monitored at the inlet of the spectrometer tube on a 20-segment bar graph. The green portion of the graph indicates normal operating vacuum level.
6	Transfer to Fine Test Switch	Holds the leak detector in gross leak mode in the <b>NO</b> position. In the <b>AUTO</b> position, it transfers into fine test mode.
7	Display Set Point Button	Displays the transfer-pressure set point on the Test Port Pressure bar graph.
8	Test Port Pressure Bar Graph	Displays the test port pressure as measured by a thermocouple gauge mounted near the test port. Used as an indicator to help prevent damage to the detector due to over-pressure situations.
9	Leak Rate Exponent Display	Indicates the leak rate range exponent in a two-digit numeric display. Capable of showing $10^{-11}$ range to $10^0$ range in atm cc/sec. The RANGE EXPONENT is also used to display the error condition code.
10	Leak Rate Mantissa Bar Graph	A 50-segment bar graph. The left most segment indicates <b>0.0</b> and is on at all times.
11	Leak Rate Over Indicator	Goes on when the upper limits of the Leak Rate scale have been exceeded.
12	Auto/Man Mode Switch	Selects automatic ranging or manual ranging. When in the <b>AUTO</b> position, the display starts each test sequence in the least sensitive range, and ranges down to the most sensitive range. When in the <b>MAN</b> position, the operator selects a single range to display the range manually.

## Models 947, 948 and 960 Leak Detectors Operations and Service Manual

---

- |    |   |  |
|----|---|--|
| 13 | Smaller/Larger Exponent Selection Buttons | When Manual Range changing is selected:<br><b>SMALLER</b> decreases the leak rate exponent.<br><b>LARGER</b> increases the leak rate exponent.<br>Holding the <b>SMALLER</b> or <b>LARGER</b> button down for more than 3 seconds (wait for the exponent to begin flashing) stores the value of the manual range exponent in EPROM. The range changes one decade each time a button is pushed. |
| 14 | Start Button                              | Press to initiate test mode.   |
| 15 | Vent Button                               | Press to initiate vent mode. This allows a test device to be connected to the 947/948/960 for leak detection.  |
| 16 | Zero Button                               | Press to initiate auto-zero sequence. The leak detector automatically zeroes a negative signal.  |
| 17 | Std Leak Button                           | Press to initiate Std leak check. Opens the standard leak test valve so that the calibrated leak can be measured to check the leak detector.   |
| 18 | Auto Cal Button                           | Press to initiate automatic calibration check. The system must be in TEST mode to initiate Auto Cal. During the check, all front panel pushbuttons are disabled. The 947/948/960 transitions back to TEST mode at the completion of the Auto Cal routine.  |
| 19 | LED Display Area                          | Refer to Section 3, "Operation" for definitions of the LEDs.   |

## 1.4 Inner Door Instruction Label

The label on the inside of the lockable turret door (Figure 1-4) provides:

- ❑ An abbreviated list of leak detector operating instructions to be used when the operator is familiar with normal operation of the 947/948/960.
- ❑ Error codes and solutions.
- ❑ The leak detector's standard leak setting as measured at the factory.

OPERATING INSTRUCTIONS		STATUS CODE INSTRUCTIONS																	
<p><b>START-UP</b> Plug unit into appropriate power supply. Turn on MAIN breaker (on rear of unit). Turn on ROUGH PUMP and DETECTOR switches (on front of unit). Wait for unit to warm up and for HOLD light to be lit, NOT READY light to be out, and no Condition Codes displayed.</p> <p><b>CALIBRATE</b> Plug test port. Set TRANSFER switch and MODE switch to AUTO. Press START button.</p> <p>699502011 2/00</p>	<p>Wait for TEST light to light. Wait approx. 1 min, then press AUTO CAL button. Wait for AUTO CAL light to go out.</p> <p>Verify machine readiness by pressing STD LEAK button. When LEAK RATE bar graph stabilizes, check that reading matches the known leak rate. Press STD LEAK button. To close leak.</p> <p><b>OPERATION</b> Press and hold VENT button (approx. one sec.). Insert test piece. Press START</p> <p><b>SHUTDOWN</b> Turn off ROUGH PUMP and DETECTOR switches. Turn off MAIN breaker on rear.</p>	<p><b>GENERAL</b></p> <p>If one Condition Code exists, it will flash.</p> <p>If more than one Condition Code exists, each will flash 4 times sequentially.</p>	<table border="1"> <thead> <tr> <th>CODE</th> <th>REMEDY</th> </tr> </thead> <tbody> <tr> <td>c2 - Detector on STANDBY mode (Rough pump off)</td> <td>Turn ROUGH PUMP on.</td> </tr> <tr> <td>c4 - No emission from ion source.</td> <td>Switch to second ion source filament.</td> </tr> <tr> <td>c5 - AUTO CAL function out of range (gain).</td> <td>Re-calibrate; see manual.</td> </tr> <tr> <td>c6 - AUTO TUNE function out of range (ion voltage).</td> <td>Re-calibrate; see manual.</td> </tr> <tr> <td>c7 - AUTO ZERO function out of range.</td> <td>Re-calibrate; see manual.</td> </tr> <tr> <td>c8 - Power interruption.</td> <td>Re-calibrate; press AUTO CAL.</td> </tr> <tr> <td>c9 - System pressure too high.</td> <td>Check for leak in vacuum system; see manual. Re-calibrate.</td> </tr> </tbody> </table>	CODE	REMEDY	c2 - Detector on STANDBY mode (Rough pump off)	Turn ROUGH PUMP on.	c4 - No emission from ion source.	Switch to second ion source filament.	c5 - AUTO CAL function out of range (gain).	Re-calibrate; see manual.	c6 - AUTO TUNE function out of range (ion voltage).	Re-calibrate; see manual.	c7 - AUTO ZERO function out of range.	Re-calibrate; see manual.	c8 - Power interruption.	Re-calibrate; press AUTO CAL.	c9 - System pressure too high.	Check for leak in vacuum system; see manual. Re-calibrate.
CODE	REMEDY																		
c2 - Detector on STANDBY mode (Rough pump off)	Turn ROUGH PUMP on.																		
c4 - No emission from ion source.	Switch to second ion source filament.																		
c5 - AUTO CAL function out of range (gain).	Re-calibrate; see manual.																		
c6 - AUTO TUNE function out of range (ion voltage).	Re-calibrate; see manual.																		
c7 - AUTO ZERO function out of range.	Re-calibrate; see manual.																		
c8 - Power interruption.	Re-calibrate; press AUTO CAL.																		
c9 - System pressure too high.	Check for leak in vacuum system; see manual. Re-calibrate.																		

Figure 1-4 Turret Door Instruction Label

## 1.5 Rear Panel Power Connection and Circuit Breakers

Figure 1-5 shows the rear power panel of the 947/948/960. Descriptions of the rear panel elements follow the figure.

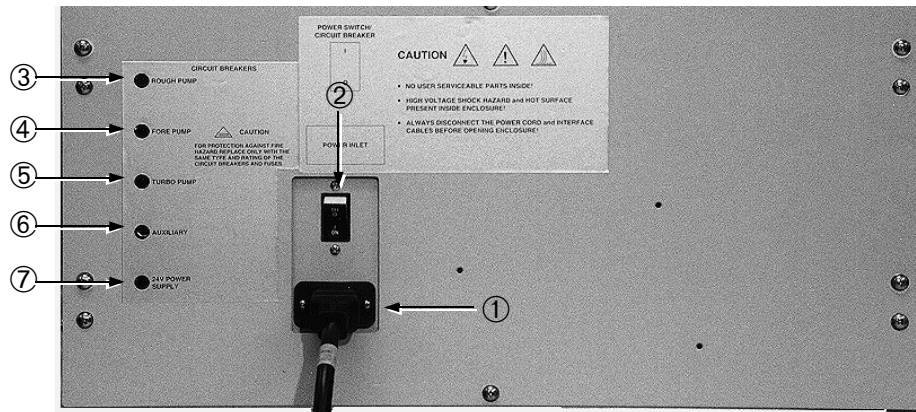

**Figure 1-5 Rear Power Panel**

Rear panel power and circuit breakers:

- |                                    |  |
|------------------------------------|--|
| ① Power Inlet                      | 115 VAC or 230 VAC power connection<br>(see Section 1.7.1, "Power" on page 1-12) |
| ② Power Switch/<br>Circuit Breaker | Mains power and Circuit breaker  |
| ③ Rough Pump                       | Circuit breaker for the Rough Pump   |
| ④ Forepump                         | Circuit breaker for the Forepump   |
| ⑤ Turbo Pump                       | Circuit breaker for the Turbo Pump   |
| ⑥ Auxiliary                        | Auxiliary Circuit breaker  |
| ⑦ 24 V Power Supply                | 24 VDC Power Supply Circuit breaker  |

## 1.6 Service Pendant

The service pendant is used to set and display parameters for the 947/948/960 Leak Detector. It is a handheld terminal with a 40-key keypad and a 20 character x 4 line backlit LCD display (see Figure 1-6). The service pendant is stored in the turret and connects to the 947/948/960 using a six-foot cable that connects to an RS-232 serial port (J1, a 9-pin D sub connector) located inside the lockable turret.

The service pendant is used to monitor and set up:

- Reject set point
- Crossover pressures
- Auto sequence parameters
- Ion Source parameters
- System setup parameters (such as the value of the calibrated leak)

Refer to Section 3.8, "Using the Pendant for Parameter Setup" on page 3-17 for further information on the operation of the service pendant.

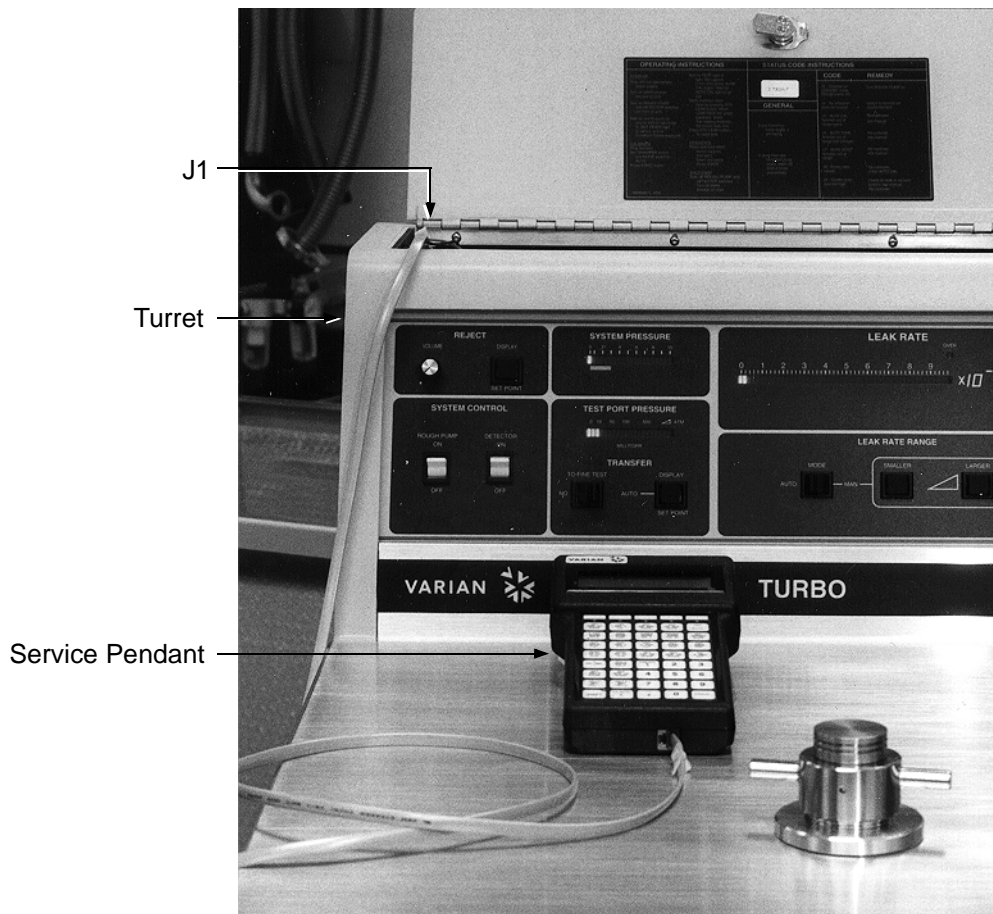

Figure 1-6 Service Pendant

## 1.7 Installation Preparation

To prepare the 947/948/960 for operation:

- Have power and liquid nitrogen (948/960 only) available
- Check oil level of wet pumps
- Adhere to special installation requirements for a clean room (if required)
- Set up an appointment for Installation services (see page 1-13)

### 1.7.1 Power

#### CAUTION



*Varian strongly recommends the use of surge protection to improve the immunity of the 947/948/960 leak detector against unidirectional transients caused by the following phenomena:*

- Switching phenomena in the power network (e.g., switching of capacitor banks)*
- Faults in the power network*
- Indirect lightning strikes*

Mains supply:

- 115 VAC, 50/60 Hz, 20 A service, or
- 230 VAC, 50/60 Hz, 15 A service (must be ordered)

#### CAUTION



*Mains supply voltage fluctuations shall not exceed  $\pm 10\%$  of the nominal voltage.*

*Transient overvoltages shall not exceed values according to Installation Categories (Overvoltage Categories) II of the UL3101-1 Standard.*

*Fixed mains socket-outlet shall be connected to PROTECTIVE EARTHING system.*

*For indoor use only, Pollution Degree II in accordance with UL3101-1 Standard.*

### 1.7.2 Liquid Nitrogen (Models 948/960 only)

The amount of liquid nitrogen needed to keep the cold trap operational is approximately three liters per day (slightly more on initial startup).



*Add liquid nitrogen to the trap **only** when the leak detector is on and under vacuum.*

### 1.7.3 Oil-Sealed Vacuum Pumps

The 947/948/960 is available with either dry or wet (oil-sealed) mechanical pumps. Units built with oil-sealed pumps are shipped with the proper initial charge of oil, however, the oil level should be checked after the pumps have been running for at least ten minutes. On the front of each of the roughing and forepumps is an oil level sight glass. See Section 4.2.9, “Rough Pump and Forepump Oil Level Check (Oil-sealed Mechanical Pumps)” on page 4-34 for instructions on how to check the oil level. The location of the mechanical pumps is shown in Abbildung B-10. If you require more information, the pump manual you received with the leak detector includes detailed instructions.

### 1.7.4 Special Installation Requirements

Additional services recommended for clean room use include:

Roughing/foreline pump exhaust hose	Vent to the outside of the room using the KF-25 (ISO NW 25) connection on the back of the leak detector. This reduces particulate count and the helium background signal.
Cooling fan air exhaust hose	Connect to the optional 4" air duct that can be installed on the back of the unit. This reduces the air flow turbulence around the machine and particle emanation from the inside of the leak detector cabinet into the clean room.
Dry vent gas	Vent using the gas fitting on the back of the leak detector for the nitrogen, or other gas. By using a dry vent gas instead of room air, moisture contact with vacuum-exposed surfaces is decreased, resulting in better pump down performance.

### 1.7.5 Installation Services

Installation, operational checkout, and operating instructions for your 947/948/960 can be provided by a qualified Varian Vacuum Technologies representative.

When your leak detector is unpacked and the required services are available, contact your local Varian Vacuum Technologies office to arrange for field installation.

## 1.8 Storage

If the leak detector is not used immediately, it can be stored as received without special precautions. A dry, relatively dust-free area is preferred. The required environmental conditions for storage are:

- ❑ 0% to 95% relative humidity, non-condensing
- ❑ -30 °F to 150 °F (-34 °C to +65 °C) ambient temperature

Refer to Section 3.7, “Shutdown” on page 3-17 if the unit is to be stored after being used. Refer to Section 3, “Operation”, of this manual for operating instructions.

## 1.9 Optional Rear Panel Interface Connections

Figure 1-7 shows the optional rear interface connection panel of the 947/948/960. Descriptions of the rear panel connectors follow the figure.

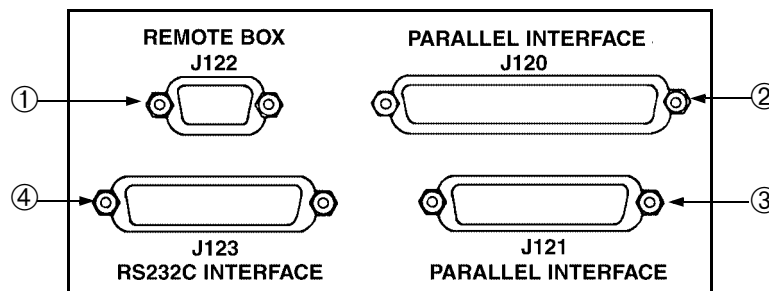

**Figure 1-7 Rear Panel Interface Connectors**

The ports available on the rear panel for connection are:

- |   |                            |   |
|---|----------------------------|---|
| ① | J122, Remote Box Interface | 9-pin female D connector for the optional Universal Remote Control  |
| ② | J120, Parallel Interface   | 37-pin female D connector for the Discrete I/O for PLC control  |
| ③ | J121, Parallel Interface   | 25-pin female D connector for Discrete BCD and analog leak rate output for PLC control  |
| ④ | J123, RS232C Interface     | 25-pin female D connector RS-232C serial port for host computer control, to monitor and change parameters in the 947/948/960 Platform |

The connections are used for in-line operation via control through a PLC. Refer to Section 2, “Leak Detector Integration” and Appendix D, “Inputs and Outputs” for further information.



# Einführung in die Lecksucher, Modell 947, 948 und 960

Die Modell 947, Modell 948 und Modell 960 von Varian Vacuum Technologies sind Plattform Auto-Test<sup>®</sup> Helium-Spektrometer-Lecksucher. In diesem Handbuch werden die Lecksucher als Modelle 947/948/960 bezeichnet.

Dieses Handbuch enthält Folgendes:

- Beschreibung der Maschinen
- Vollständige Betriebsanleitungen, einschließlich Beschreibungen der Steuereinheiten und Anzeigen, Wartungs-, Kalibrierungs- und Anschlussverfahren
- Informationen zur Fehlersuche

Informationen bezüglich Konformität, Garantie und Sicherheit befinden sich im ersten Teil dieses Handbuchs. Diese Informationen sind vor Inbetriebnahme der Maschine zu lesen.

Die 947/948/960 verfügen über stabile Metallgehäuse, die auf Rollen montiert sind, um eine bessere Mobilität zu gewährleisten. Der Zugang zum verschließbaren Aufsatz, in dem die Hängebedienungs- und Anzeigetafel untergebracht ist, erfolgt mittels eines Schlüssels.

Die 947/948/960 bestehen aus folgenden Grundkomponenten:

- Mechanische Vorvakuumpumpe
- Mechanische Grobvakuumpumpe
- Spektrometerrohr
- Contra-Flow<sup>™</sup> Vakuumsystem (960 benutzt konventionelles Strömungssystem)
- Plattformelektronik
- Fronttafel und Anzeigen

Die 947/948/960 können für Trocken- oder Nasspumpen konfiguriert werden. Die 948/960 verfügen über eine Stickstoff-Kühlfalle.

Plattformelektronik, Hängebedienungs- und Anzeigetafel befinden sich im Aufsatz. Informationen über die Leckrate und den Systemstatus werden auf der Fronttafel angezeigt und sind außerdem über den E/A an der rückseitigen Schalttafel verfügbar.

Modell 947 ist in Abbildung 1-8 zu sehen. Beschreibungen des Aufsatzes und der Betriebstasten, die in Abbildung 1-8 gekennzeichnet sind, entsprechen der Abbildung. Modelle 948/960 sind in Abbildung 1-9 zu sehen.

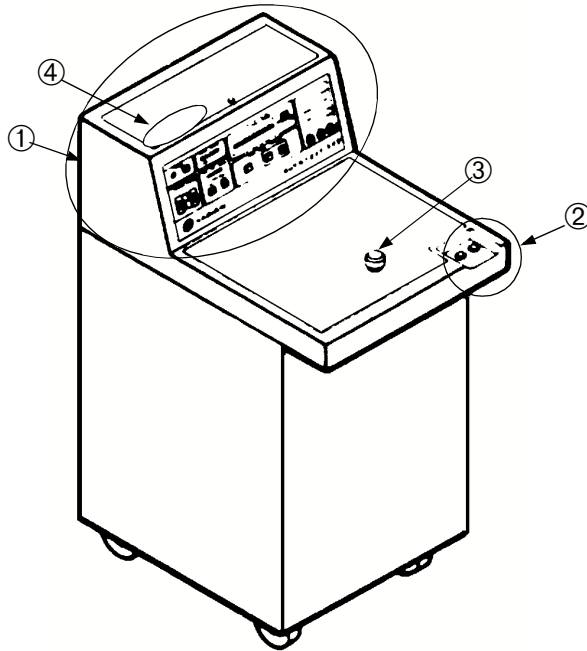

**Abbildung 1-8 947 Lecksucher**

- |                      |  |
|----------------------|--|
| ① Aufsatz            | Aufbewahrungsort für Hängebedienungstafel und Elektronik |
| ② Betriebstasten     | Start- und Ablasstasten                                  |
| ③ Prüfausgang        | Anschlussstelle  |
| ④ Standard Leckkabel | Etikett mit internem Standard-Leckwert                   |

Modelle 948/960 sind in Abbildung 1-9 zu sehen. Die Tür auf der Arbeitsfläche der 948/960 ermöglicht den Zugang zur Stickstoff-Kühlfalle. Beschreibungen des Aufsatzes, der Betriebstasten und Stickstoff-Kühlfalle, die in Abbildung 1-9 gekennzeichnet sind, entsprechen der Abbildung.

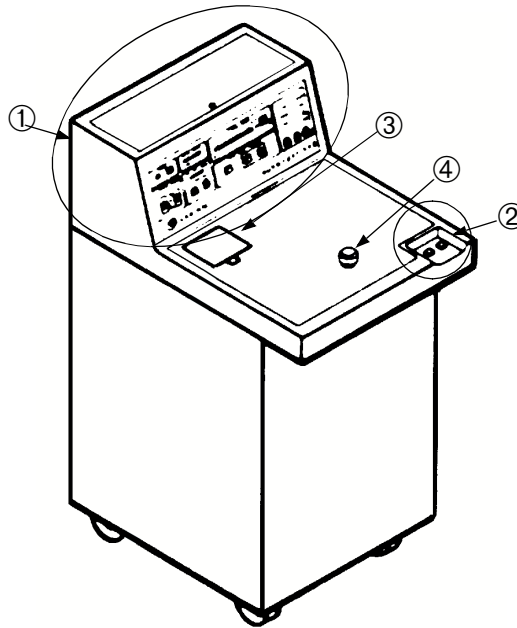

**Abbildung 1-9 948/960 Lecksucher**

- |                           |  |
|---------------------------|--|
| ① Aufsatz                 | Aufbewahrungsort für Hängebedienungstafel und Elektronik |
| ② Betriebstasten          | Start- und Ablasstasten                                  |
| ③ Flüssigstickstoff-Falle | Zugang zur Flüssigstickstoff-Falle                       |
| ④ Prüfausgang             | Anschlussstelle  |

### 1.10 Plattformelektronik

Die 947/948/960 benutzen die Plattform-Lecksuchelektronik von Varian Vacuum Technologies,

um:

- Die Spektrometereinheit zu betätigen
- Die mechanischen und Hochvakuum-Pumpen zu steuern
- Die Ventile zu steuern
- Informationen über die Leckrate und den Systemstatus an die Bedienerschnittstelle und den rückseitigen E/A zu leiten

Eine hochentwickelte Elektronikplattform sorgt für umfassende diagnostische Informationen und ermöglicht eine Justierung ohne Messpunkte oder Potentiometer. Bei der Plattform handelt es sich um eine Ansammlung von Leiterplatten, welche unter Verwendung der PC/104 Buskonstruktion betätigt werden, um die verschiedenen Funktionen eines Helium-Spektrometer-Lecksuchers zu auszuführen. Der Mikroprozessor speichert weiterhin die wichtigsten Einstellparameter und sichert sie auf dem EPROM. Auf diese Weise wird eine schnelle Wiederherstellung nach vorübergehendem Verlust der Leitungsspannung gewährleistet.

### 1.11 Auspacken der 947/948/960

Beim Versand der 947/948/960 werden folgende Teile eingeschlossen:

- Lecksucher, Modelle 947/948/960
- Hängebedienungstafel
- Stromkabel (115 VAC oder 230 VAC)
- Pumpenhandbücher (für die erworbene Konfiguration)

Nehmen Sie vor dem Öffnen des Containers auf die *Anleitungen zum Auspacken* an der Außenseite des Versandcontainers Bezug. Die 947/948/960 wurden sorgfältig auf eine schwingungsdämpfende Palette gestellt und in einen stabilen, an der Palette befestigten Pappkarton gepackt. Die Werksverpackung gewährleistet maximalen Schutz während des Transports.

### 1.11.6 Anleitungen zum Auspacken

Gehen Sie beim Auspacken und Lösen der 947/948/960 von der Palette wie folgt vor:

1. Untersuchen Sie den Container auf Anzeichen von während des Transports entstandenen Schäden.
    - a. Entsorgen Sie keine Beweise schlechter Handhabung.
    - b. Setzen Sie den Spediteur und den Kundendienst von Varian Vacuum Technologies unter
    - c. 1-800-8VARIAN unverzüglich von allen Schäden in Kenntnis.
  2. Entfernen Sie vorsichtig die äußeren Versandbehälter.
  3. Untersuchen Sie den Lecksucher und zugehörige Teile unverzüglich auf Anzeichen von während des Transports entstandenen Schäden.
  4. Schneiden Sie die Riemen, mit denen der Lecksucher auf der Palette befestigt ist, vorsichtig durch.
  5. Entfernen Sie alle losen Kästen oder Pakete und legen Sie diese zur Seite. Bewahren Sie die Originalverpackung für den Fall auf, dass eine Rücksendung des Lecksuchers an Varian Vacuum Technologies erforderlich ist.
  6. Entfernen Sie vorsichtig die vordere Klammer, indem Sie die beiden Bolzen lösen.
  7. Entfernen Sie vorsichtig die Plastiktüte, welche den Lecksucher umgibt.
- Jetzt kann der Lecksucher von der Palette genommen werden.

### 1.11.7 Entfernen der 947/948/960 von der Palette

Die 947/948/960 können auf zweierlei Weise von der Palette entfernt werden. Für beide Vorgehensweisen sind jeweils zwei Personen erforderlich. Die zweite Vorgehensweise schließt den Ausbau der Skid-Mates von der Palette ein.

#### **WARNUNG**



*Achten Sie bei den folgenden Schritten auf eine vorsichtige, vorschriftsmäßige Handhabung des Lecksuchers. Eine unsachgemäße Handhabung des Lecksuchers kann Personenschäden oder eine Beschädigung der Maschine zur Folge haben. Die 947/948/960 sind schwer und können Personenschäden verursachen, wenn sie beim Entfernen von der Palette nicht vorsichtig gehandhabt werden.*

### Vorgehensweise 1

1. Rollen Sie den Lecksucher mit Hilfe einer zweiten Person vorsichtig zur Vorderseite der Palette.
2. Heben Sie das vordere Ende der Einheit an und senken Sie sie behutsam auf den Boden.
3. Heben Sie die Rückseite der Einheit an und schieben Sie sie auf den vorderen Rollen, bis sie die Palette nicht mehr berührt.
4. Senken Sie die Rückseite der Einheit behutsam auf den Boden.

### Vorgehensweise 2

1. Benutzen Sie die in Schritt 6 der "Anleitungen zum Auspacken" entfernte Klammer als Hebel und heben Sie damit vorsichtig die Vorderkante der Palette um 25 mm bis 50 mm an.
2. Bitten Sie eine zweite Person, den Lecksucher gegen die hintere Klammer zu drücken, und lösen und entfernen Sie die beiden vorderen Skid-Mates (die blauen ringförmigen Vorrichtungen an der Vorderseite der Palette), indem Sie sie gegen den Uhrzeigersinn drehen.
3. Vergewissern Sie sich, dass die zweite Person den Lecksucher nach wie vor gegen die Rückseite der Palette drückt, und senken Sie dann vorsichtig die Vorderkante der Palette auf den Boden.
4. Rollen Sie den Lecksucher nun vorsichtig und langsam von der Palette auf den Boden.

### 1.11.8 Entfernen der losen Verpackungsteile aus dem Innenraum der 947/948/960

Sobald die 947/948/960 von der Palette entfernt wurden, müssen die losen Verpackungsteile im Innenraum beseitigt werden.

1. Öffnen Sie die Fronttafel der 947/948/960, welche den Hauptzugang für Wartungsarbeiten an den Pumpen und dem Spektrometerrohr darstellt.
2. Entfernen Sie alle losen Verpackungsteile aus dem Innenraum des Lecksuchers.

## 1.12 Anzeigen und Steuerelemente der Fronttafel

Die Steuerelemente und Anzeigen der Fronttafel werden in Abbildung 1-10 anhand von Zahlen gekennzeichnet Abbildung 1-10.



Abbildung 1-10 Anzeigen und Steuerelemente der Fronttafels

- |   |                                  |  |
|---|----------------------------------|--|
| 1 | Lautstärkenregelung              | Steuert die Lautstärke des akustischen Leckratensignals.   |
| 2 | Anzeigetaste                     | Zeigt unter Verwendung des Leckraten-Balkendiagramms mit 50 Unterteilungen und des entsprechenden Bereichsexponenten den ausgewählten Rückweisungsgrenzwert des Lecksuchers an.            |
| 3 | Netzschalter der Grobvakuumpumpe | Steuert die Stromversorgung der Grobvakuumpumpe.   |
| 4 | Netzschalter des Lecksuchers     | Steuert die Stromversorgung der Vorvakuumpumpe und der Hochvakuumpumpe.  |
| 5 | Systemdruck-Balkendiagramm       | Zeigt den am Eingang des Spektrometerrohrs gemessenen Systemdruck auf einem Balkendiagramm mit 20 Unterteilungen an. Der grüne Bereich des Diagramms zeigt ein normales Betriebsvakuum an. |

- |    |                                      |   |
|----|--------------------------------------|---|
| 6  | Prüfschalter "Umstellen auf Fein"    | Stellt den Lecksucher im Großleckmodus in der Position NEIN fest. In der Position <b>AUTO</b> erfolgt eine Umstellung auf den Feinprüfmodus.  |
| 7  | Anzeige Sollwerttaste                | Zeigt den Sollwert des Übertragungsdrucks auf dem Prüfausgangsdruck-Balkendiagramm an.  |
| 8  | Prüfausgangsdruck-Balkendiagramm     | Zeigt den Prüfausgangsdruck an, der von einem in der Nähe des Prüfausgangs angebrachten Thermoelement-Prüfgerät gemessen wird. Seine Angaben tragen dazu bei, eine Beschädigung des Lecksuchers durch Überdruckbedingungen zu verhindern.   |
| 9  | Leckraten-Exponentenanzeige          | Gibt den Exponenten des Leckratenbereichs als zweistellige numerische Anzeige wieder. Kann einen Bereich von $10^{-11}$ bis $10^0$ in atm cc/Sek. anzeigen. Der BEREICHSEXONENT dient auch zur Angabe des Fehlerzustandscodes.  |
| 10 | Leckraten-Mantissenbalkendiagramm    | Ein Balkendiagramm mit 50 Unterteilungen. Die Unterteilung links außen zeigt <b>0,0</b> an und ist immer aktiviert.   |
| 11 | Anzeige für Leckraten-Überschreitung | Leuchtet auf, wenn der obere Grenzwert des Leckratenbereichs überschritten wurde.   |
| 12 | Modusschalter Auto/Man               | Dient zur Auswahl der automatischen oder manuellen Bereichseinstellung. In der Position <b>AUTO</b> beginnt das Display die einzelnen Prüffolgen im unempfindlichsten Bereich und fährt bis zum empfindlichsten Bereich fort. In der Position <b>MAN</b> wählt der Bediener einen einzelnen Bereich aus, um ihn manuell anzuzeigen. |

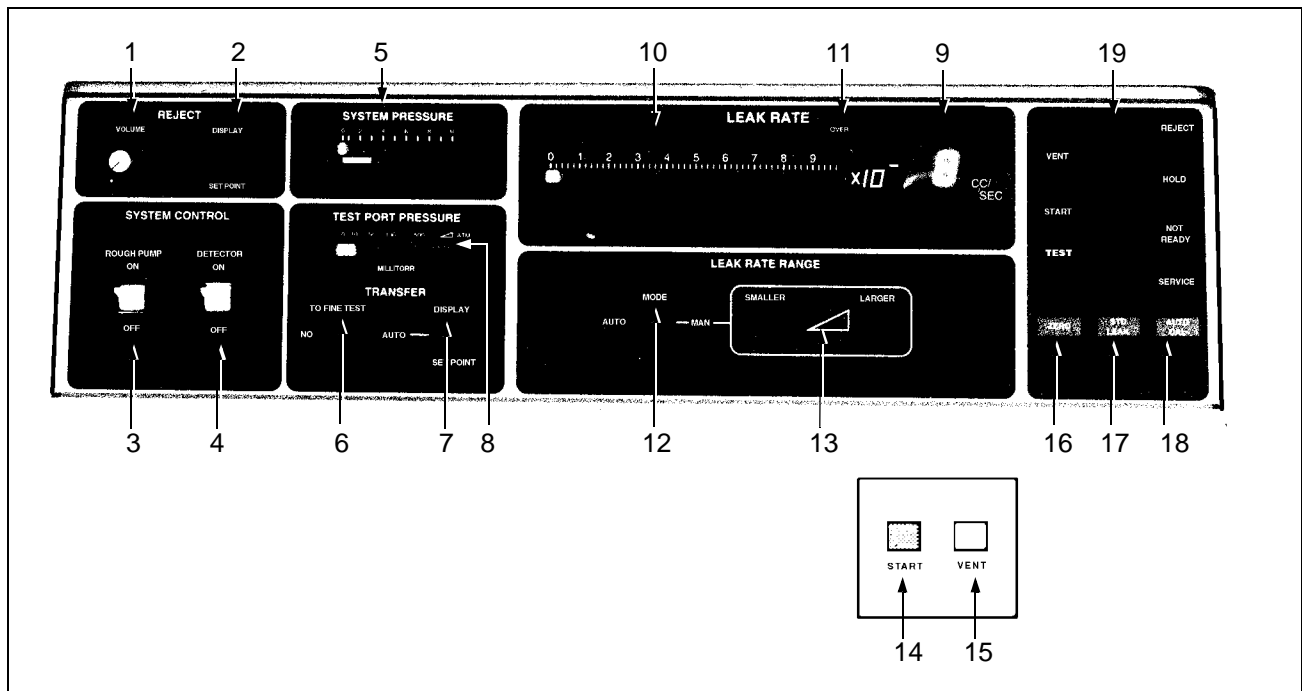

- |    |  |  |
|----|--|--|
| 13 | Wahltasten für kleinere / größere Exponenten | Bei einer Auswahl der manuellen Bereichsänderung:<br>verringert <b>KLEINER</b> den Exponenten der Leckrate.<br>erhöht <b>GRÖSSER</b> den Exponenten der Leckrate.<br>Wird die Taste <b>KLEINER</b> oder <b>GRÖSSER</b> länger als 3 Sekunden niedergehalten (warten Sie, bis der Exponent aufzublinken beginnt), wird der Wert des manuellen Bereichsexponenten auf dem EPROM gespeichert. Mit jedem Tastendruck ändert sich der Bereich um eine Dekade. |
| 14 | Starttaste                                   | Drücken Sie diese Taste, um den Prüfmodus zu initiieren.   |
| 15 | Ablasstaste                                  | Drücken Sie diese Taste, um den Ablassmodus zu initiieren. Dies ermöglicht den Anschluss eines Prüfgeräts an die 947/948/960 zwecks Lecksuche.   |
| 16 | Null-Taste                                   | Drücken Sie diese Taste, um eine automatische Nullstellung durchzuführen. Der Lecksucher stellt ein negatives Signal automatisch auf Null ein.   |
| 17 | Standardleck-Taste                           | Drücken Sie diese Taste, um eine Standard-Lecksuche zu initiieren. Das Standard-Lecksuchventil wird geöffnet, um das kalibrierte Leck messen und den Lecksucher prüfen zu können.  |
| 18 | Taste zur automatischen Kalibrierung         | Drücken Sie diese Taste, um eine automatische Kalibrierung zu initiieren. Um eine automatische Kalibrierung zu initiieren, muss sich das System im Prüfmodus befinden. Während der Prüfung sind alle Drucktasten auf der Fronttafel deaktiviert. Nach Abschluss des automatischen Kalibrierungsverfahrens kehren die 947/948/960 wieder zum Prüfmodus zurück.  |
| 19 | LED-Anzeigebereich                           | Für Definitionen der LED siehe Abschnitt 3, "Operation".   |

## 1.13 Anweisungsschild an der Innentür

Das Schild an der Innenseite der verschließbaren Aufsatztür (Abbildung 1-11) enthält folgende Angaben:

- ❑ Eine verkürzte Liste der Betriebsanleitungen des Lecksuchers, die dann zu benutzen ist, wenn der Bediener mit dem normalen Betrieb der 947/948/960 vertraut ist.
- ❑ Fehlercodes und Lösungen
- ❑ Die Standard-Leckeinstellung des Lecksuchers nach Werksmessung

OPERATING INSTRUCTIONS		STATUS CODE INSTRUCTIONS																	
<p><b>START-UP</b> Plug unit into appropriate power supply. Turn on MAIN breaker (on rear of unit). Turn on ROUGH PUMP and DETECTOR switches (on front of unit). Wait for unit to warm up and for HOLD light to be lit, NOT READY light to be out, and no Condition Codes displayed.</p> <p><b>CALIBRATE</b> Plug test port. Set TRANSFER switch and MODE switch to AUTO. Press START button.</p> <p>699502011 2/00</p>	<p>Wait for TEST light to light. Wait approx. 1 min, then press AUTO CAL button. Wait for AUTO CAL light to go out. Verify machine readiness by pressing STD LEAK button. When LEAK RATE bar graph stabilizes, check that reading matches the known leak rate. Press STD LEAK button. To close leak.</p> <p><b>OPERATION</b> Press and hold VENT button (approx. one sec.). Insert test piece. Press START</p> <p><b>SHUTDOWN</b> Turn off ROUGH PUMP and DETECTOR switches. Turn off MAIN breaker on rear.</p>	<p><b>GENERAL</b></p> <p>If one Condition Code exists, it will flash.</p> <p>If more than one Condition Code exists, each will flash 4 times sequentially.</p>	<table border="1"> <thead> <tr> <th>CODE</th> <th>REMEDY</th> </tr> </thead> <tbody> <tr> <td>c2 - Detector on STANDBY mode (Rough pump off)</td> <td>Turn ROUGH PUMP on.</td> </tr> <tr> <td>c4 - No emission from ion source.</td> <td>Switch to second ion source filament.</td> </tr> <tr> <td>c5 - AUTO CAL function out of range (gain).</td> <td>Re-calibrate; see manual.</td> </tr> <tr> <td>c6 - AUTO TUNE function out of range (ion voltage).</td> <td>Re-calibrate; see manual.</td> </tr> <tr> <td>c7 - AUTO ZERO function out of range.</td> <td>Re-calibrate; see manual.</td> </tr> <tr> <td>c8 - Power interruption.</td> <td>Re-calibrate; press AUTO CAL.</td> </tr> <tr> <td>c9 - System pressure too high.</td> <td>Check for leak in vacuum system; see manual. Re-calibrate.</td> </tr> </tbody> </table>	CODE	REMEDY	c2 - Detector on STANDBY mode (Rough pump off)	Turn ROUGH PUMP on.	c4 - No emission from ion source.	Switch to second ion source filament.	c5 - AUTO CAL function out of range (gain).	Re-calibrate; see manual.	c6 - AUTO TUNE function out of range (ion voltage).	Re-calibrate; see manual.	c7 - AUTO ZERO function out of range.	Re-calibrate; see manual.	c8 - Power interruption.	Re-calibrate; press AUTO CAL.	c9 - System pressure too high.	Check for leak in vacuum system; see manual. Re-calibrate.
CODE	REMEDY																		
c2 - Detector on STANDBY mode (Rough pump off)	Turn ROUGH PUMP on.																		
c4 - No emission from ion source.	Switch to second ion source filament.																		
c5 - AUTO CAL function out of range (gain).	Re-calibrate; see manual.																		
c6 - AUTO TUNE function out of range (ion voltage).	Re-calibrate; see manual.																		
c7 - AUTO ZERO function out of range.	Re-calibrate; see manual.																		
c8 - Power interruption.	Re-calibrate; press AUTO CAL.																		
c9 - System pressure too high.	Check for leak in vacuum system; see manual. Re-calibrate.																		

Abbildung 1-11 Anweisungsschild auf Aufsatztür

## 1.14 Rückseitige Schalttafelstromanschluss und Trennschalter

Abbildung 1-12 zeigt die rückseitige Schalttafel der 947/948/960. Die Beschreibungen der Elemente auf der rückseitigen Schalttafel entsprechen der Abbildung.

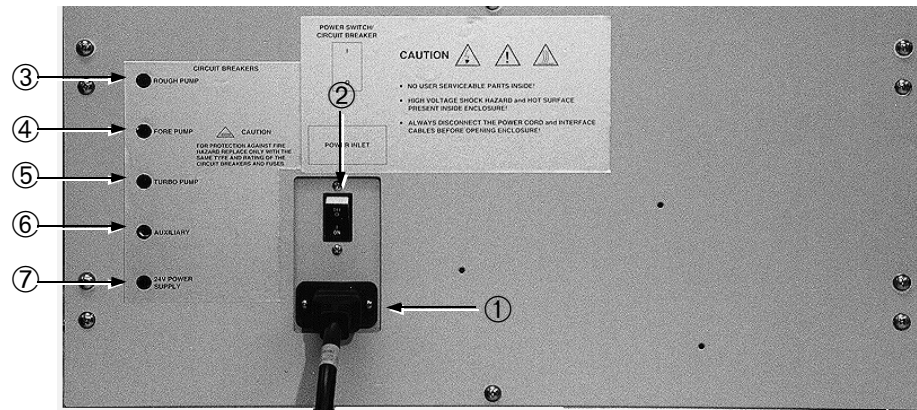

**Abbildung 1-12 Rückseitige Schalttafel**

Strom- und Trennschalter auf der rückseitigen Schalttafel

- |                                  |   |
|----------------------------------|---|
| ① Stromeinspeisung               | 115 VAC oder 230 VAC Stromanschluss<br>(siehe Abschnitt 1.16.1, "Strom" auf Seite 1-27) |
| ② Netzschalter/<br>Trennschalter | Netzstrom- und Trennschalter  |
| ③ Grobvakuumpumpe                | Trennschalter für die Grobvakuumpumpe   |
| ④ Vorvakuumpumpe                 | Trennschalter für die Vorvakuumpumpe  |
| ⑤ Turbopumpe                     | Trennschalter für die Turbopumpe  |
| ⑥ Zusätzlicher Schalter          | Zusätzlicher Trennschalter  |
| ⑦ 24 V Stromversorgung           | Trennschalter der 24 VDC Stromversorgung  |

## 1.15 Hängebedienungstafel

Die Hängebedienungstafel dient zum Einstellen und Anzeigen von Parametern für die Lecksucher 947/948/960. Es handelt sich dabei um eine handgehaltene Einheit mit einem 40 Tasten umfassenden Tastenfeld und einer hinterleuchteten Flüssigkristallanzeige aus 20 Zeichen x 4 Zeilen (siehe Abbildung 1-13). Die Hängebedienungstafel wird im Aufsatz aufbewahrt und wird anhand eines 2m langen Kabels an einen seriellen Anschluss (J1, ein 9-Pin D Neben verbinder) im verschließbaren Aufsatz an die 947/948/960 angeschlossen.

Die Hängebedienungstafel dient zur Überwachung und Einstellung folgender Werte:

- Rückweisungs-Sollwert
- Crossover-Druckwerte
- Parameter der automatischen Sequenz
- Parameter der Ionenquelle
- Parameter der Systemeinstellung (wie der Wert des kalibrierten Lecks)

Für weitere Informationen über den Betrieb der Hängebedienungstafel siehe Abschnitt 3.17, "Parametereinstellung mit der Hängebedienungstafel" auf Seite 3-38.



Abbildung 1-13 Hängebedienungstafel

## 1.16 Vorbereitung zur Installation

Bereiten Sie die 947/948/960 wie folgt auf den Betrieb vor:

- Vergewissern Sie sich, dass ein Stromanschluss und Flüssigstickstoff (nur 948/960) verfügbar sind.
- Prüfen Sie den Ölstand der Nasspumpen.
- Beachten Sie spezielle Installationsanforderungen für Reineräume (falls erforderlich).
- Vereinbaren Sie einen Termin für den Installationsdienst (siehe Abschnitt 1.16.5, "Installationsdienste" auf Seite 1-29).

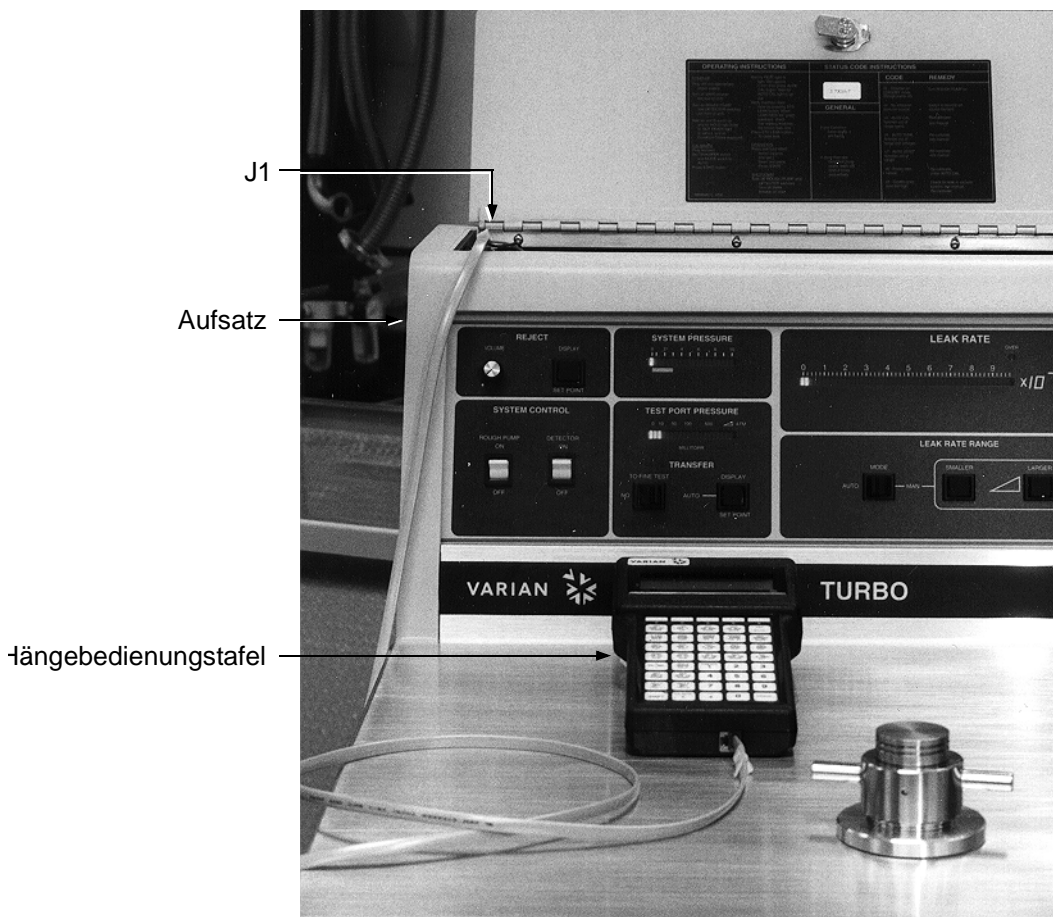
### 1.16.1 Strom

#### VORSICHT



*Varian empfiehlt dringend die Verwendung eines Überspannungsschutzes, um die Sicherheit der Lecksucher 947/948/960 bei durch folgende Ereignisse verursachten, einseitigen Überschwankungen zu verbessern:*

- Schaltereignisse im Stromnetz (z.B. Schalten von Kondensatorbatterien)*
- Fehler im Stromnetz*
- Indirekte Blitzschläge*

Netzstromversorgung

- 115 VAC, 50/60 Hz, 20 A Versorgung oder
- 230 VAC, 50/60 Hz, 15 A Versorgung (muss geordnet sein)

#### VORSICHT



*Schwankungen in der Netzstromversorgung dürfen um maximal  $\pm 10\%$  von der nominalen Spannung abweichen.*

*Momentane Überspannungen dürfen die Werte der Installationskategorien (Überspannungskategorien) II des UL3101-1 Standards nicht überschreiten.*

*Die fest montierten Netzsteckdosen müssen an ein SCHUTZERDUNGSSYSTEM angeschlossen sein.*

*Nur zur Verwendung in Gebäuden:  
Verschmutzungsgrad II in Übereinstimmung mit dem UL3101-1 Standard.*

*Flüssigstickstoff (nur Modell 948/960)*

### 1.16.2 Flüssigstickstoff (nur Modell 948/960)

Die Menge des Flüssigstickstoffs, die zur Wahrung der Betriebsfähigkeit der Kühlfalle erforderlich ist, beträgt ca. drei Liter täglich (bei der ersten Inbetriebnahme etwas mehr).

#### HINWEIS



*Füllen Sie die Kühlfalle **nur** dann mit Flüssigstickstoff auf, wenn der Lecksucher eingeschaltet ist und unter Vakuum steht.*

### 1.16.3 Öldichte Vakuumpumpen

Die 947/948/960 sind mit mechanischen (öldichten) Trocken- oder Nasspumpen erhältlich. Mit öldichten Pumpen ausgerüstete Einheiten werden mit der richtigen anfänglichen Ölmenge geliefert. Nach einem mindestens zehnminütigen Betrieb der Pumpen muss der Ölstand jedoch geprüft werden. An der Vorderseite jeder Grob- und Vorvakuumpumpe befindet sich ein Ölstand-Sichtfenster. Für Anleitungen zum Prüfen des Ölstands siehe Abschnitt 4.2.9, "Rough Pump and Forepump Oil Level Check (Oil-sealed Mechanical Pumps)" auf Seite 4-34 Die Position der mechanischen Pumpen ist Abbildung B-10 zu entnehmen. Sollten Sie detailliertere Informationen benötigen, nehmen Sie bitte Bezug auf das mit dem Lecksucher gelieferte Pumpenhandbuch.

### 1.16.4 Spezielle Anforderungen bei der Installation

Zur Verwendung in Reinräumen sind folgende zusätzliche Leitungen erforderlich:

Ablassleitung für Grob-/Vorvakuumpumpe	Ablass aus dem Raum unter Verwendung des KF-25 (ISO NW 25) Verbinders an der Rückseite des Lecksuchers. Auf diese Weise wird die Anzahl der Schwebstoffteilchen und das Helium-Hintergrundsignal reduziert.
Ablassleitung für Luft vom Kühlgebläse	Anschluss an optionale 10cm Luftleitung, die an die Rückseite der Einheit angebracht werden kann. Auf diese Weise wird die Luftstromturbulenz um die Maschine und die Partikelemanation aus dem Inneren des Lecksuchergehäuses in den Reinraum verringert.
Trockenablassgas	Für diesen Ablass wird für den Stickstoff oder anderes Gas das Gasfitting an der Rückseite des Lecksuchers benutzt. Durch die Verwendung eines Trockenablassgases anstelle von Raumluft wird der Kontakt der dem Vakuum ausgesetzten Flächen mit Feuchtigkeit reduziert, was zu einer besseren Leistung bei ausgeschalteten Pumpen führt.

### 1.16.5 Installationsdienste

Installation, Betriebsprüfungen und Betriebsanleitungen für ihre 947/948/960 sind von einem qualifizierten Varian Techniker von Vacuum Technologies erhältlich.

Wenn Sie Ihren Lecksucher ausgepackt haben und der gewünschte Dienst verfügbar ist, wenden Sie sich bitte an Ihre nächste Varian Vacuum Technologies Niederlassung, um einen Termin für eine Installation vor Ort zu vereinbaren.

### 1.17 Aufbewahrung

Soll der Lecksucher nicht sofort benutzt werden, kann er nach dem Empfang ohne besondere Vorkehrungen aufbewahrt werden. Ein trockener, relativ staubfreier Ort ist vorzuziehen. Die erforderlichen Umgebungsbedingungen zur Aufbewahrung sind.

- 0% bis 95% relative Feuchtigkeit ohne Kondensation
- 34 °C bis +65 °C Umgebungstemperatur

Soll die Einheit nach der Benutzung aufbewahrt werden, siehe Abschnitt 3.16, "Abschalten" auf Seite 3-37. Für Betriebsanleitungen siehe "Betrieb" on page 3-19 in diesem Handbuch.

## 1.18 Optionale Anschlüsse an der rückseitigen Schalttafel

Abbildung 1-14 zeigt die optionale rückseitige Schalttafel der 947/948/960. Die Beschreibungen der Anschlüsse auf der rückseitigen Schalttafel entsprechen der Abbildung.

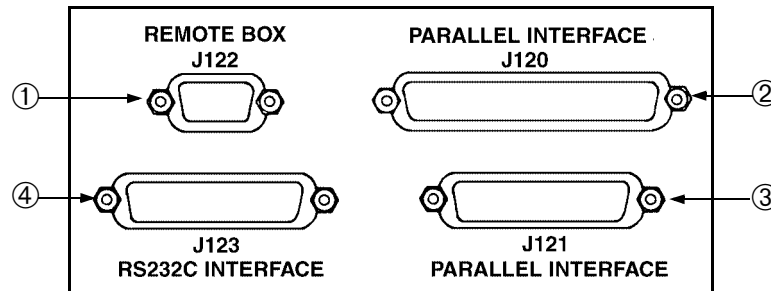

**Abbildung 1-14 Schnittstellenanschlüsse an der rückseitigen Schalttafel**

An der rückseitigen Schalttafel sind folgende Anschlüsse verfügbar:

- ① J122, Schnittstelle für die 9-Pin Buchse D für die optionale Universal-Fernsteuerung Fernsteuerungs-Box
- ② J120, parallele Schnittstelle 37-Pin Buchse D für den diskreten E/A zur SPS-Steuerung
- ③ J121, parallele Schnittstelle 25-Pin Buchse D für die diskrete BCD und die analoge Leckratenausgabe zur SPS-Steuerung
- ④ J123, RS232C Schnittstelle 25-Pin Buchse D RS-232C serieller Port zur Steuerung des Hostrechners zur Überwachung und Änderung der Parameter auf der 947/948/960 Plattform

Die Anschlüsse dienen zum unmittelbaren Betrieb anhand einer Steuerung durch eine SPS. Für weitere Informationen siehe Abschnitt 2, "Leak Detector Integration" und Anhang D, "Inputs and Outputs".



## Section 2. Leak Detector Integration

Although Models 947/948/960 are considered stand-alone units, all the models can be incorporated into a production line connected to a host computer or PLC.

This section details the setup and operation of Models 947/948/960 into a production line, or for use as automated equipment, rather than stand-alone equipment.

### 2.1 Physical Considerations

An integrated 947/948/960 has the same physical considerations as a manually operated unit.

### 2.2 Common Configuration

The 947/948/960 is ordered as needed from Varian Vacuum Technologies with the pumps installed. If changes are needed for integration into a system, contact Varian Vacuum Technologies Customer Service at 1-800-8VARIAN. The available pumps are listed in Appendix E, "947/948 Specifications".

In Figure 2-1 and Figure 2-3 on page 2-5, valves are designated by numbers in white circles (①), other key parts of the vacuum system are designated by numbers in black circles (❶). The key parts are identified below the figure. The valve numbers are used in Table 2-1. The valve name and type are defined in the upper portion of the table, the state of each valve based system status is shown in the lower portion of each table.

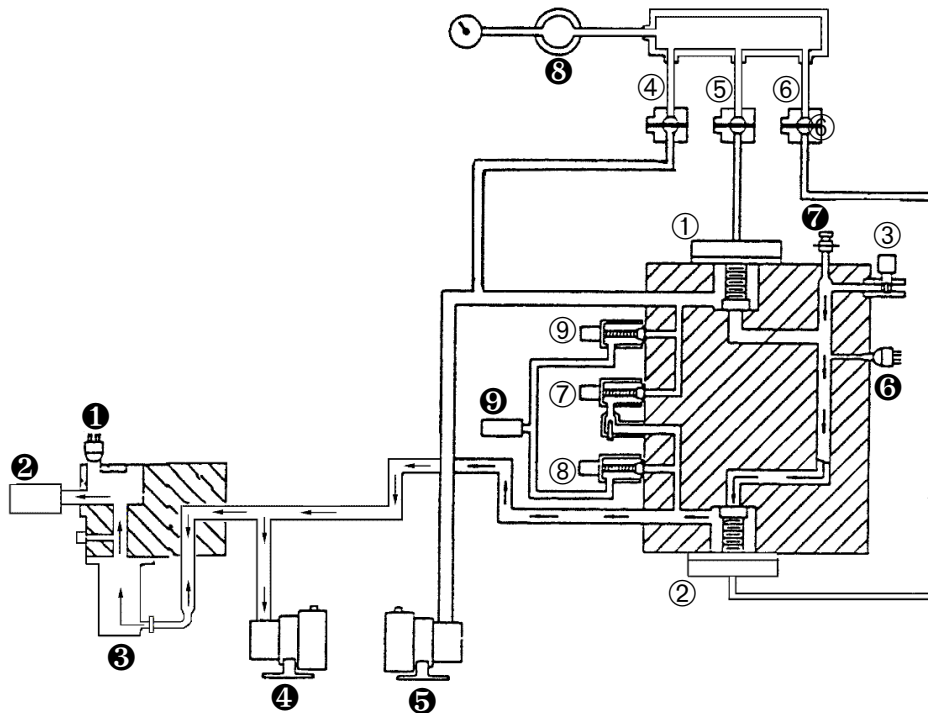

**Figure 2-1 947 Flow Diagram**

- |                            |                            |
|----------------------------|----------------------------|
| ❶ Thermocouple Gauge (TC2) | ❹ Thermocouple Gauge (TC1) |
| ❷ Spectrometer Tube        | ❺ Test Port                |
| ❸ Turbo Pump               | ❻ Reservoir                |
| ❹ Forepump                 | ❼ Standard Leak            |
| ❺ Rough Pump               |                            |

In Abbildung 2-2 und Abbildung 2-4 on page 2-6, werden Ventile durch Nummern in weißen Kreisen (①), andere wichtige Teile des Vakuumsystems durch Nummern in schwarzen Kreisen (❶) gekennzeichnet. Die wichtigen Teile werden in der nachfolgenden Abbildung identifiziert. Die Ventilnummern werden in Table 2-1. Table 2-1 benutzt. Name und Typ des Ventils werden im oberen Teil der Tabelle definiert, der Zustand der einzelnen Ventile je nach Systemzustand werden im unteren Teil der einzelnen Tabellen angezeigt.



Abbildung 2-2 947 Ablaufdiagramm

- |                                 |                                 |
|---------------------------------|---------------------------------|
| ❶ Thermoelement-Messgerät (TC2) | ❷ Thermoelement-Messgerät (TC1) |
| ❸ Spektrometerrohr              | ❹ Prüfport                      |
| ❺ Turbopumpe                    | ❻ Speicher                      |
| ❻ Vorvakuumpumpe                | ❼ Standard Leck                 |
| ❼ Grobvakuumpumpe               |                                 |

## Models 947, 948 and 960 Leak Detectors Operations and Service Manual

Table 2-1 serves two purposes. In the upper portion, the valve name and type are defined. In the lower portion, Table 2-1 indicates the valve state (open or closed) in relation to the system status for testing the 947/948/960. The following abbreviations are used in Table 2-1:

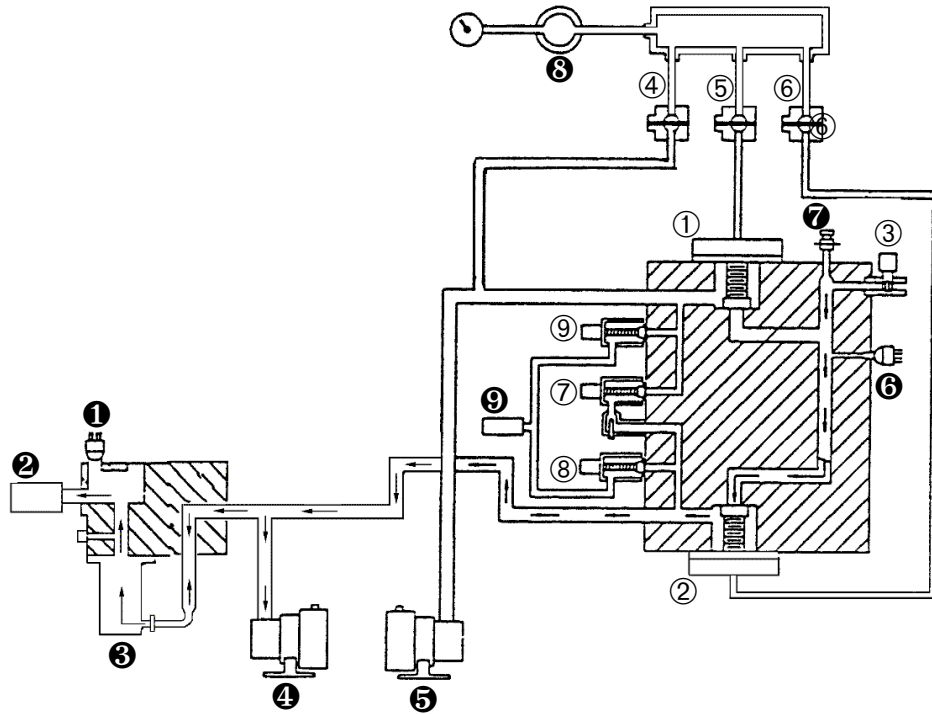
V=Vacuum

O=Open

S=Solenoid

C=Closed. All valves are normally closed.

**Table 2-1 Valve Operation**

Valve Name	Valve Type		Valve Number		Valve Name	Valve Type		Valve Number						
	V	S	①	⑤		V	S	②	⑥	③	④	⑦	⑧	⑨
Rough	V		①		Test Valve Operator	V	S	②	⑥	Vent	S			
Rough Valve Operator		S		⑤						Reservoir Rough	S			
Test										Gross Leak	S			
Test Valve Operator										Standard Test Leak	S			
Vent										Standard Leak Rough	S			

System Status	Valve State							
Vent	C	C	O	O	C	C	O	
Start Rough	O	C	C	C	C	C	C	
Gross Test	O	C	C	C	O	C	C	
Fine Test	C	O	C	O	C	C	O	
Auto Cal	C	O	C	O	C	O	C	
Hold and Fault	C	C	C	O	C	C	O	

Refer to Figure 2-3 on page 2-5 for valve locations.

In Figure 2-3, numbers in white circles designate the location of valves. Other key parts of the vacuum system, represented by numbers in black circles, are identified after Figure 2-3.

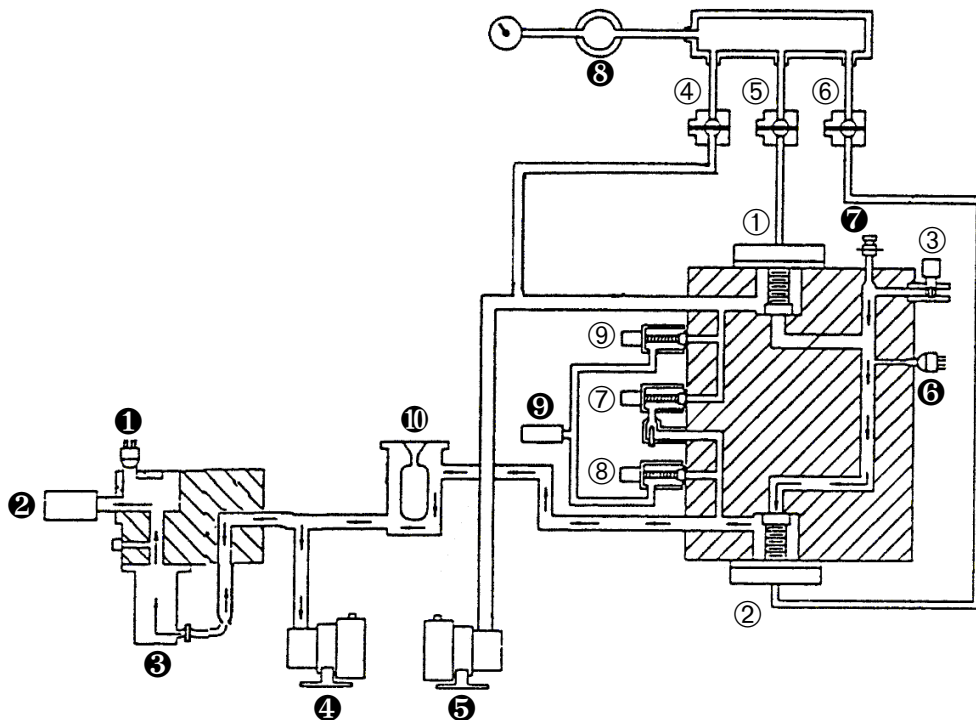

**Figure 2-3 948 Flow Diagram**

- |                            |                            |
|----------------------------|----------------------------|
| ① Thermocouple Gauge (TC2) | ⑥ Thermocouple Gauge (TC1) |
| ② Spectrometer Tube        | ⑦ Test Port                |
| ③ Turbo Pump               | ⑧ Reservoir                |
| ④ Forepump                 | ⑨ Standard Leak            |
| ⑤ Rough Pump               | ⑩ Nitrogen Cold Trap       |

In Abbildung 2-4 kennzeichnen die Nummern in weißen Kreisen die Position der Ventile. Andere wichtige Teile des Vakuumsystems, angezeigt durch Nummern in schwarzen Kreisen, werden nach Abbildung 2-4 identifiziert.

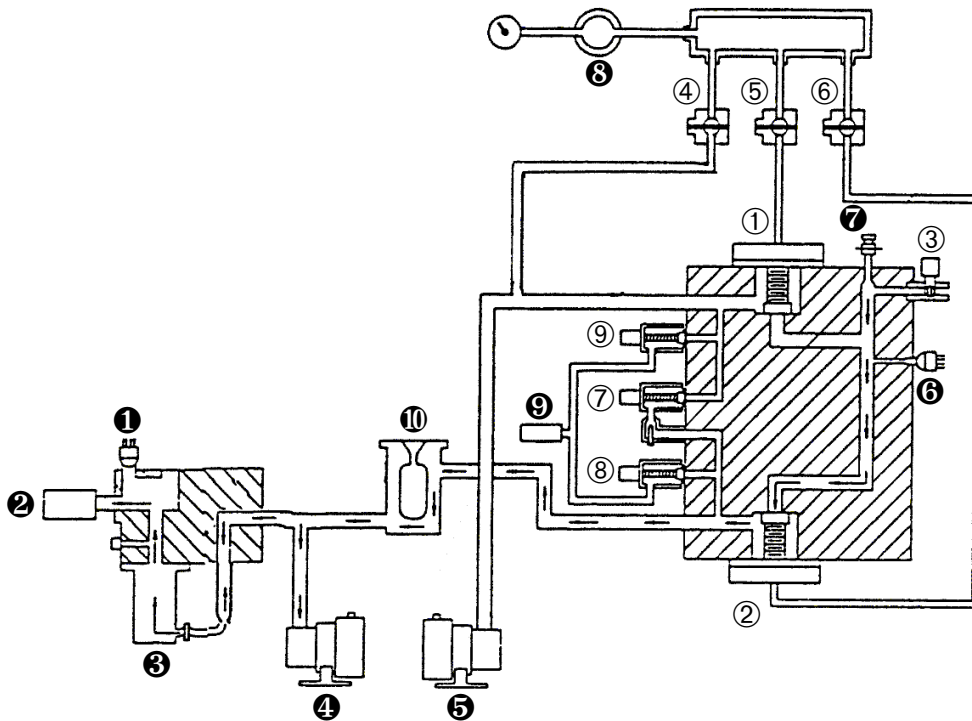

**Abbildung 2-4 948 Ablaufdiagramm**

- |                                 |                                 |
|---------------------------------|---------------------------------|
| ❶ Thermoelement-Messgerät (TC2) | ❷ Thermoelement-Messgerät (TC1) |
| ❸ Spektrometerrohr              | ❹ Prüfport                      |
| ❺ Turbopumpe                    | ❻ Speicher                      |
| ❻ Vorvakuumpumpe                | ❼ Standard Leck                 |
| ❼ Grobvakuumpumpe               | ❽ Stickstoffkühlfalle           |

## Models 947, 948 and 960 Leak Detectors Operations and Service Manual

In Figure 2-5, numbers in white circles designate the location of valves. Other key parts of the vacuum system, represented by numbers in black circles, are identified after Figure 2-5.

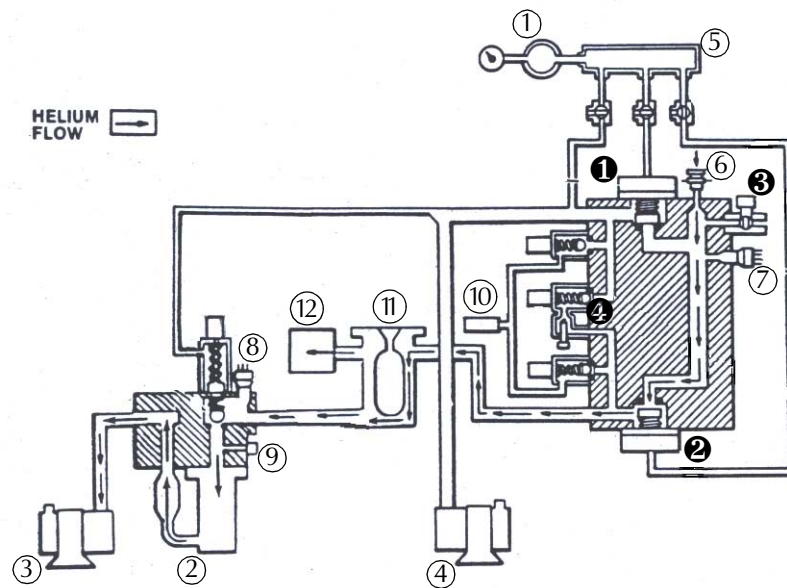

**Figure 2-5 960 Flow Diagram**

- |                        |                            |                    |
|------------------------|----------------------------|--------------------|
| ① Reservoir            | ⑦ Thermocouple Gauge (TC1) | ① Rough Valve      |
| ② Turbo/Diffusion Pump | ⑧ Thermocouple (TC2)       | ② Test Valve       |
| ③ Forepump             | ⑨ System Pressure Gauge    | ③ Vent Valve       |
| ④ Rough Pump           | ⑩ Standard Leak            | ④ Cross Leak Valve |
| ⑤ Manifold             | ⑪ Nitrogen Cold Trap       |                    |
| ⑥ Test Port            | ⑫ Spectrometer Tube        |                    |

In Figure 2-6, numbers in white circles designate the location of valves. Other key parts of the vacuum system, represented by numbers in black circles, are identified after Figure 2-6.

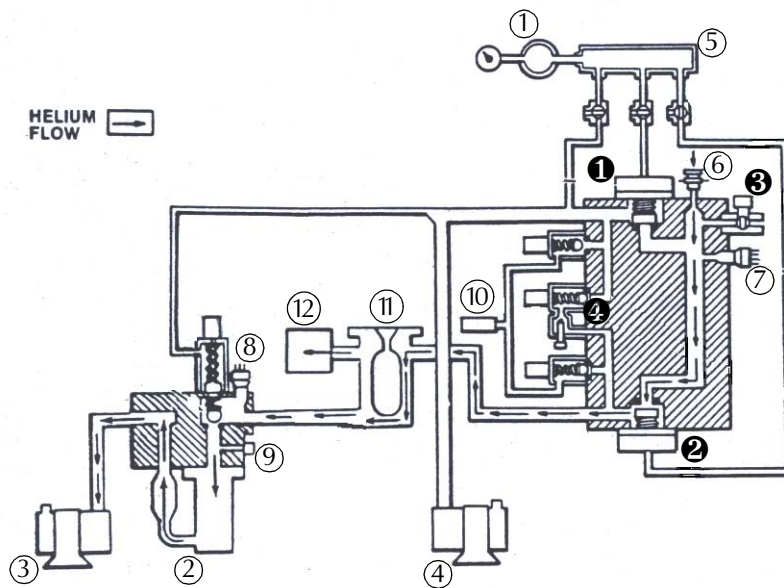

**Figure 2-6 960 Flow Diagram**

- |                        |                            |                    |
|------------------------|----------------------------|--------------------|
| ① Reservoir            | ⑦ Thermocouple Gauge (TC1) | ① Rough Valve      |
| ② Turbo/Diffusion Pump | ⑧ Thermocouple (TC2)       | ② Test Valve       |
| ③ Forepump             | ⑨ System Pressure Gauge    | ③ Vent Valve       |
| ④ Rough Pump           | ⑩ Standard Leak            | ④ Gross Leak Valve |
| ⑤ Manifold             | ⑪ Nitrogen Cold Trap       |                    |
| ⑥ Test Port            | ⑫ Spectrometer Tube        |                    |



## 2.3 Electronic Considerations for the Optional Rear Panel Interface

This section includes information necessary to interface the 947/948/960 with a PLC or a host computer using either serial or parallel communications through the optional rear panel interface via J120 Discrete I/O, J121 BCD Outputs and J123 Host Serial Port.

### 2.3.1 Discrete I/O J120 Inputs

The discrete I/O is used to control operations via a PLC. Table 2-2 provides the input connections.

**Table 2-2 J120 Input Connections**

Pin on J120	Input Name	Momentary or Level	Description
1	Ground return for J120 only		
2	Reject Output	Active High	Leak rate signal is higher than reject set point.
3	Stop	200 msec high pulse	Unit goes to vent mode.
4	Start	200 msec high pulse	Goes to fine test via rough gross modes.
6	Parallel Enable	Active High	Enables rear panel PLC Interface.
7	Zero	200 msec high pulse	Begins Auto Zero routine.
9	Auto Cal	200 msec high pulse	Begins Auto Calibrate.
10	Decrement	200 msec high pulse	Decrements the exponent when in manual ranging.
11	Increment	200 msec high pulse	Increments the exponent when in manual ranging.
12	Auto Range	Active High	Automatically changes the exponent to keep the reading in range.
14	Hold		Places the system in Hold mode.
15	Filament Fault	Active High	Active when selected ion source filament is non-functional.
16	Not Ready	Active High	Not ready to run – possible fault.
18	CAL OK	Active High	Active when last CALIBRATE successful.
19	Zeroing	Active High	Active when Auto Zeroing.

**Table 2-2 J120 Input Connections (Continued)**

<b>Pin on J120</b>	<b>Input Name</b>	<b>Momentary or Level</b>	<b>Description</b>
21	Calibrating	Active High	Active when Auto Cal.
23	Ready	Active High	Active when system is operating (inverse of "Not Ready").
25	Ground return for J120 only		
27, 28	+24 VDC for Output Sourcing		

### 2.3.2 BCD J121 Outputs

Table 2-3 provides the J121 output connections.

**Table 2-3 J121 Output Summary**

<b>Pin on J121</b>	<b>Signal Name</b>	<b>Momentary or Level</b>	<b>Description</b>
1, 2	Ground for J121		
3	LSD A	Active High	BCD Leak Rate
4	LSD B	Active High	BCD Leak Rate
5	LSD C	Active High	BCD Leak Rate
6	LSD D	Active High	BCD Leak Rate
7	MSD A	Active High	BCD Leak Rate
8	MSD B	Active High	BCD Leak Rate
9	MSD C	Active High	BCD Leak Rate
10	MSD D	Active High	BCD Leak Rate
11	LSD A	Active High	BCD Leak Rate
12	LSD B	Active High	BCD Leak Rate
13	LSD C	Active High	BCD Leak Rate
14	LSD D	Active High	BCD Leak Rate
15	MSD A	Active High	BCD Leak Rate
16	MSD B	Active High	BCD Leak Rate
17	MSD C	Active High	BCD Leak Rate

**Table 2-3 J121 Output Summary**

18	MSD D	Active High	BCD Leak Rate
20, 21	+24 VDC for Output Sourcing		
24, 25	Ground for J121		

### 2.3.3 Host Serial Port J123 Pinouts

The Host Serial Port is used to interface the 947/948/960 to a PLC or host computer via an RS-232 connection. Table 2-4 provides details about the connection.

J123 connections are referenced to the chassis ground and are not isolated. Electrical characteristics comply with EIA/TIA Standard EIA/TIA-232-E.

**Table 2-4 J123 Pinout Summary**

Pin on J123	Signal Name	Description
1	Shield	Shield for J123, System Ground
2	RXD	RS-232 Data
3	TXD	RS-232 Data
4	CTS	RS-232 Flow Control
5	RTS	RS-232 Flow Control
6	DTR	RS-232 Flow Control
7	Data Ground	Signal Return for J123
20	DSR	RS-232 Flow Control

## 2.4 Optional Interface Connections

Available ports for interface connection:

- ❑ Service RS-232 serial port for a service pendant or host computer to monitor and change parameters in the 947/948/960 Platform (J1 male 9-pin D connector in the Service compartment)
- ❑ RS-232 serial port for a high speed host computer or PLC to control, monitor, and change parameters in the 947/948/960 Platform (J123 female 25-pin connector)
- ❑ Discrete I/O port for PLC control (J120 female 37-pin D connector)
- ❑ Discrete BCD and analog leak rate output port for PLC control (J121 female 25-pin D connector)
- ❑ Optional Universal Remote Control Box port the (J122 female 9-pin D connector)

Refer to Appendix D, "Inputs and Outputs" for available rear panel ports, pinouts, and signal designations.

The rear panel connectors are shown in Figure 2-7.

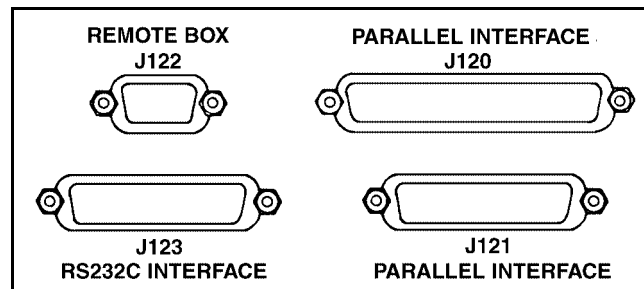

**Figure 2-7 Rear Panel**

### 2.4.1 Grounding and Isolation

The service, remote, and rear panel RS-232 ports in the 947/948/960 are referenced to the chassis ground and to the system ground.

## 2.4.2 Setup

Parameters relating to the operation and performance of the 947/948/960 Platform are stored in EPROM. These parameters can be viewed and changed via the service pendant or rear serial ports.

A standard host computer with an RS-232 port, or PLC is used for connection to and control of the rear panel serial port (J123). Only the pre-programmed Varian Vacuum Technologies setup/service pendant is used for connection to and control of the service RS-232 port. The keypad inputs and instructions (Appendix A, "Service Pendant Keypad Functions") are used to determine certain internal operating parameters.

Some parameters are set when the system is assembled and tested. Other parameters are changed when a gauge is changed or when the ion source or preamplifier is changed. Some parameters are changed automatically during power up, or when functions such as the Auto Cal, or Auto Zero run.

## 2.4.3 Discrete I/O

J120 and J121 connectors contain the discrete I/O lines. This section provides the information necessary to be able to use discrete I/Os.

The following items relate to the circuits shown in Figure 2-8:

- ❑ The discrete I/O lines are optically isolated and grouped by connector.
- ❑ J120 contains status and control inputs and outputs.
- ❑ J121 contains the BCD and analog voltage leak rate outputs.
- ❑ The power and return connections to J120 are isolated from J121 and from the equipment and system grounds.
- ❑ The power and return connections for the BCD outputs in J121 are also isolated from J120 and the equipment and system grounds.

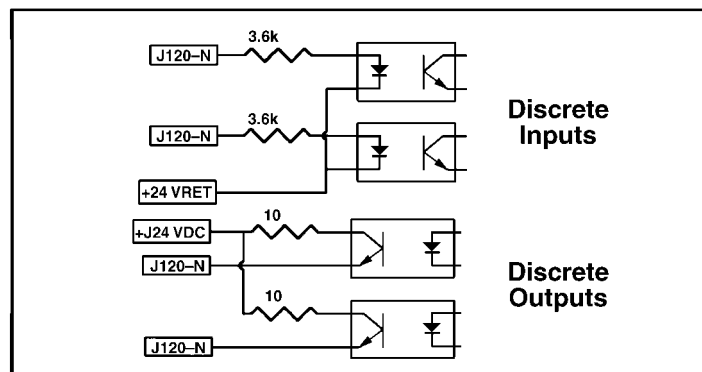

**Figure 2-8 Discrete Inputs/Outputs Isolated**

If the I/O on J120 is used, then:

- ❑ +5 VDC to +24 VDC must be applied to J120, pins 27 and 28.
- ❑ The +5 VDC to +24 VDC return must be connected to J120, pins 1 and 25.

If the I/O on J121 is used, then:

- ❑ +5 VDC to +24 VDC must be applied to J121, pins 20 and 21.
- ❑ The +24 VDC return must be connected to J121, pins 1, 2, 24, and 25.
- ❑ The grounds between J120, J121, and chassis grounds are exclusive.

When using the discrete I/O, Allen-Bradley's 1746-IBx and 1746-OBx (or equivalent) modules for the SLC 500-series PLCs are recommended.

The analog leak rate output voltage on J121, pin 22, and return on J121, pin 23, have the return referenced to the system ground.

The discrete inputs are:

- ❑ Opto-isolated with the negative side of the inputs combined and tied to the return pins of the associated connector.
- ❑ The input voltage range is +5 VDC to +24 VDC.
- ❑ The maximum input current (at 24 VDC) drawn by each input is 7 mA.

The discrete outputs are:

- ❑ Opto-isolated Darlington transistor emitter followers with the collectors combined and tied to the +24 VDC pins of the associated connector.
- ❑ The maximum current that can be drawn from each output is 20 mA.
- ❑ The output voltage supply range is +5 VDC to +24 VDC.



*When operating the 947/948/960 from the discrete I/O, it is necessary to make the PARALLEL ENABLE (J120 pin 6) active. This allows the controller to accept commands from the other discrete I/O inputs. Making PARALLEL ENABLE active also disallows any changes to the operating parameters through the front panel or serial ports (service pendant). Requests for changes made through the serial ports are responded to with **cant**.*

## 2.5 Operation using the Optional Rear Panel Interface

Once setup is complete and the 947/948/960 is warmed up, operation can be turned over to the discrete I/O by asserting the PARALLEL ENABLE input (J120 pin 6). Operations can be monitored using the front panel display, or via a PLC.

### 2.5.1 Parallel Enable

The PARALLEL ENABLE input turns control of the 947/948/960 over to the discrete I/O for efficient operation. Once PARALLEL ENABLE is asserted, operations can be monitored using the host serial port, but most parameter values cannot be changed. If a command is issued that is not allowed once PARALLEL ENABLE is asserted, the system response is *cant*. See Appendix C, "Communications Protocol".

Operations can be monitored on the front panel display, but the parameter values cannot be changed using the front panel. See Appendix D, "Inputs and Outputs".

To remove control from the discrete I/O, you must de-assert PARALLEL ENABLE (J120 pin 6).



*Control remains with the discrete I/O, even if the leak detector is shut down while PARALLEL ENABLE is asserted.*

*This page intentionally left blank.*



## Section 3. Operation

To obtain accurate readings using the 947/948/960 leak detectors, follow the operational procedures listed in this section. The 947/948/960 measure the leak rate in atm cc/sec.

The procedures explain how to:

- ❑ Start and warm up the 947/948/960.
- ❑ Calibrate the 947/948/960.
- ❑ Set the parameters to obtain accurate readings.
- ❑ Operate the 947/948/960 to obtain precision leak readings using helium.
- ❑ Put the 947/948/960 in STANDBY mode, and/or shut it down entirely for maintenance or storage.

Parameter setup using the service pendant applies to both stand-alone (manual) and in-line production operation.

### 3.1 Front Panel LED Indicators and Controls

Figure 3-1 shows the LED indicators and controls on the front panel (right hand side) of the 947/948/960 turret. The buttons are defined in Section 1.3, "Front Panel Controls and Indicators" on page 1-6.

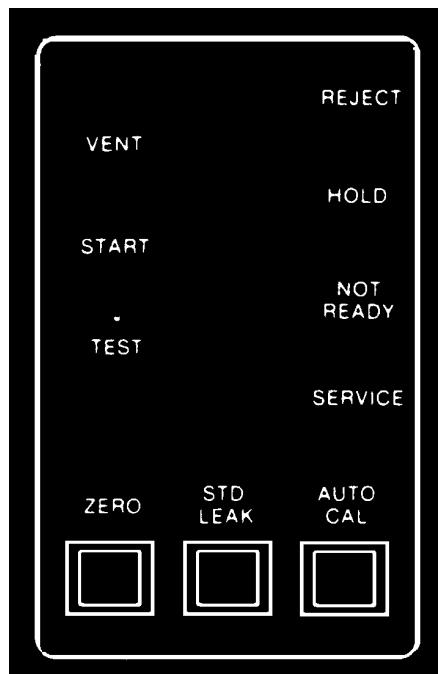

Figure 3-1 Front Panel LED Indicators and Controls

## Models 947, 948 and 960 Leak Detectors Operations and Service Manual

---

During operation, the LED functions are illuminated to indicate the operation being performed. The definitions of the operations are as follows:

VENT	Illuminates when the vent valve is open. The LED is off when the valve is closed.
START	Illuminates when the START button is pushed. Goes off one second after the TEST LED illuminates, or immediately when the VENT, HOLD, or NOT READY LEDs illuminate.
TEST	Illuminates when 947/948/960 is in test mode; either the gross leak valve or the test valve is open. Otherwise, the LED is off.
ZERO	Illuminates when the ZERO button is pushed or when the auto-zero sequence is performed as part of the auto-calibrate sequence. Goes off one second after the auto-zero sequence is completed or if the leak detector goes into a not-ready condition. The ZERO LED flashes when the signal falls below zero. The ZERO LED also flashes during startup when the system is nulling the preamplifier.
REJECT	Illuminates when the reject function is on and when the leak rate reading exceeds the selected set point. Goes off when the leak rate falls below the set point.
HOLD	Illuminates if the machine is in the HOLD mode with the test and roughing valves closed. The HOLD mode is selected by momentarily pressing the VENT button if the machine is in TEST. When in HOLD, pressing either the START or VENT button launches the next operation.
NOT READY	Illuminates whenever a not-ready condition exists. The particular error condition code, c0 through c9, is displayed on the RANGE DISPLAY. See Table 3-1 on page 3-12 for information on the error codes.
AUTO CAL	If the leak detector is in TEST mode, illuminates when the AUTO CAL button is pushed, disabling all other front panel push buttons, including START and VENT. AUTO CAL is only functional when the leak detector is in TEST mode. The machine returns to TEST mode at completion of the AUTO CAL routine.
STD LEAK	Illuminates when the standard leak test valve is opened. This occurs when the STD LEAK button is pushed or during the auto-calibrate function. Goes off when the standard leak test valve is closed by pressing the STD LEAK button.
SERVICE	Not used.

### 3.2 Initial System Parameter Setup

The 947/948/960 performs functions and tests based upon parameter values. Some parameters are entered and set when the system is assembled and tested. Some parameters are calculated and change automatically during power up, Calibrate, or Zero functions. Other parameters are changed when a change is made to the physical system, such as when a thermocouple gauge, ion source or preamplifier is changed. These parameters are set as a function of the physical configuration and sensitivity needs.

Several parameters relating to the operation and performance are stored in EPROM in the control unit. The information for these parameters is not lost when the power is shut down. Parameters can be viewed and changed through commands entered via the service pendant or host computer.

Section 3.2.1, "Parameters and Operating Modes" explains the parameters and what happens during the related function.

#### 3.2.1 Parameters and Operating Modes

The parameters and operating modes work together to perform leak detection, and the parameters that are entered determine the type of test and sensitivity of testing performed. The discussion below includes an explanation of what the parameter or function means. For additional information on how to set a parameter or select a function, refer to Section 3.3, "Start-Up" on page 3-9 and Appendix A, "Service Pendant Keypad Functions", or if the optional rear panel interface is installed, Section C, "Communications Protocol".

RANGE	The 947/948/960 automatically sets the Range equal to the exponent of the least sensitive range of the leak detector, depending on the sensitivity of the vacuum system.
AUTO-RANGE and MANUAL RANGE	Auto-Ranging causes the leak detector to automatically change the leak rate exponent and mode to keep the leak rate reading on scale.  Manual Range is used to force the 947/948/960 to display a leak rate in only one decade (the exponent never changes). This feature is useful when the test operator is only concerned with monitoring the leak rate measurement within a single decade. Set the Leak Rate Range Mode to MAN and use the SMALLER or LARGER buttons to change the range.
RANGE STOP	The RANGE STOP feature configures the 947/948/960 so that it only auto-ranges down to the pre-selected decade entered in the range stop variable field. For example, if RANGE STOP is enabled and set to -07, then the most sensitive range that the leak detector displays is $10^{-7}$ .

This feature is useful when a product specification is more than one decade less stringent than the sensitivity of the leak detection system as it is configured. If the configured system is capable of detecting  $10^{-9}$  atm cc/sec but the test specification is only in the  $10^{-7}$  atm cc/sec range, then setting the RANGE STOP to -08 reduces the test cycle time by eliminating the need for the leak detector to reach its most sensitive decade ( $10^{-9}$ ) during each test cycle.

### AUTO CAL

Used to perform an automated calibration based upon the parameters set. Calibration is compared to a known internal leak.

To perform an automated calibration, press the AUTO CAL button, or assert calibrate input via the serial port or optional discrete I/O.

### CALIBRATED LEAK VALUE

The 947/948/960 is shipped from the factory with a calibrated leak. Its value is noted on the turret of the leak detector and on the Cal Leak Certification. When a calibration is performed, the system compares the leak rate signal with the stored value. The tuning process involves independently scanning the ion source chamber voltage and the variable focus voltage, and optimizing each value for a maximum helium signal. Once the tuning process is complete, the system gain is adjusted to bring the leak detector into calibration.

### ZERO

The ZERO function reads the background leak rate signal, stores the reading in memory, and then resets the zero reference point. Subsequent actual test measurements include both helium from the real leak and helium from background conditions, however, the recorded background signal from the measurement is subtracted and the resultant real leak rate is displayed. To perform a ZERO function, press the ZERO button, or assert ZERO input via serial port or optional discrete I/O.

#### NOTE



*Performing the ZERO function while introducing helium to the test object can result in the suppression of a real leak. Only use the ZERO function after the helium source has been removed.*

REJECT SET POINTS	The REJECT SET POINTS are used to alert the operator that a measured leak rate has exceeded the set value. There are four set points available. Each set point must be enabled before they are operational. Conversely, each must be disabled to stop its operation. Only one set point can be active at any given time.
AUDIO VOLUME	The AUDIO VOLUME control is used to activate the audio tone from the turret. The audio tone frequency increases as the size of the measured leak increases. The audio volume control is located on the turret.
BAR GRAPH DISPLAY	The 50-segment bar graph display on the front control panel represents the mantissa value of the leak rate, spanning from 0 to 10. The scale shows above the bar graph. The numerical display, located to the far right of the bar graph, displays the leak rate exponent value in atm cc/sec.
LINEAR VS LOG OUTPUT	Configure the analog output voltage to the optional I/O port on the back of the unit. The options for output are linear or logarithmic at 2 VDC per decade or 3 VDC per decade.

### AUTO-SEQUENCER

Provides clear accept/reject signals and allows programming for roughing, testing, and cycling times. Auto sequencer provides the ability to set up the 947/948/960 so that it automatically runs through a complete test cycle (START/ROUGH/TEST/VENT), passing or failing the test part per the test specification entered by the user. The auto sequencer set-up controls include test object rough time, test time, and auto sequencer on/off. A Pass or Fail condition is determined based upon the reject set point selected by the user and/or achievement of the pressure transfer set points within the period of time specified in Rough Time.

The auto sequencer pass or fail leak rate value is selected through the Reject Set Point. The pass/fail criterion is based on the reject set point that is enabled (ON). If more than one set point is enabled, then the pass/fail criterion is based on the most stringent reject set point value.

A Pass condition is indicated by the system reverting to the VENT mode upon completion of the test cycle. A fail condition results in REJECT being displayed in the LED display area, and a reject set point activation upon completion of the test cycle. A Fail condition is also indicated by the system reverting to the HOLD mode, and all operating buttons being disabled except VENT. The status of the reject set points is available at the optional I/O communications port (host computer) and upon inquiry through the service pendant (Appendix A, "Service Pendant Keypad Functions").

Upon the completion of an automated test cycle, the 947/948/960 captures the leak rate signal measured just prior to the end of the automated test cycle. This leak rate is displayed and held at the analog output communications port until the next test cycle is initiated. This allows the end user to record the actual leak rate value for each test object.

### ROUGH TIME

The ROUGH TIME variable determines the amount of time that the leak detector is allowed to evacuate the test object to the tolerable test transfer pressure. In AUTO SEQUENCER mode, the 947/948/960 transfers into test as soon as the tolerable transfer pressure is met. It does not wait for the total rough time allotted if it is not required. If the tolerable test transfer pressure is not achieved within the pre-selected rough time, the system aborts the cycle and goes into HOLD mode.

The ROUGH TIME value can be determined empirically and should reflect the typical time required to rough the test object to the tolerable test pressure. Failure to achieve the tolerable test pressure within the pre-selected rough time is an indication of a gross leak in the test object or test fixturing or that the time allowed was insufficient.

### TEST TIME

The TEST TIME variable determines the amount of time that the leak detector remains in test before it compares the measured leak rate with the selected reject set point. Sufficient time must be allowed for the leak rate reading to stabilize before the system makes a pass/fail decision. This is a function of the part configuration and the leak rate specification. In AUTO SEQUENCER mode, the 947/948/960 remains in test for the entire duration of the preselected test time.

### FINE TEST MODE

When FINE TEST (normal operating mode) is used, the leak detector automatically tests for gross leaks and then transfers into fine test if no gross leaks are detected.

GROSS TEST ONLY  
(nur Grobprüfung)  
HOLDING IN GROSS FOR  
LARGE LEAKS  
(Grobtestposition für große  
Lecks wird gehalten)

The 947/948/960 Leak Detector uses the Contra-Flow system, which has a gross leak manifold, allowing testing at higher inlet pressure with reduced sensitivity.

When TRANSFER TO FINE TEST is set to NO, the leak detector does not transfer into FINE TEST mode. This feature is useful for qualifying parts that have an unusually high rate of gross leak failures prior to fine leak testing.

### TRANSFER POINTS

Set the test transfer pressures for each testing mode.

The transfer pressure settings can be adjusted to lower values for specific applications. The 947/948/960 has pre-programmed upper transfer pressure limits that are slightly greater than the default settings. These limits prevent the operator from inadvertently setting the 947/948/960 to transfer into test at too high a pressure, resulting in excessive spectrometer tube contamination or ion source filament failure.

### GROSS LEAK XFER

The GROSS LEAK XFER set point determines the test pressure cross over point at which the 947/948/960 transfers into the GROSS LEAK TEST mode. In the GROSS LEAK TEST mode, the majority of the sampled gas is pumped away through the dedicated roughing pump while a small sample of gas is introduced into the leak detector through a throttle valve.



### 3.3 Start-Up

To operate the 947/948/960, you need:

- ❑ Test fixtures appropriate to the unit under test
- ❑ Helium tank with spray gun or hook up for auto test (Helium for the 948/960)

Figure 3-2 shows the important 947/948/960 operation controls for start up and power. For circuit breaker descriptions, refer to Section 1.5, "Rear Panel Power Connection and Circuit Breakers" on page 1-10.

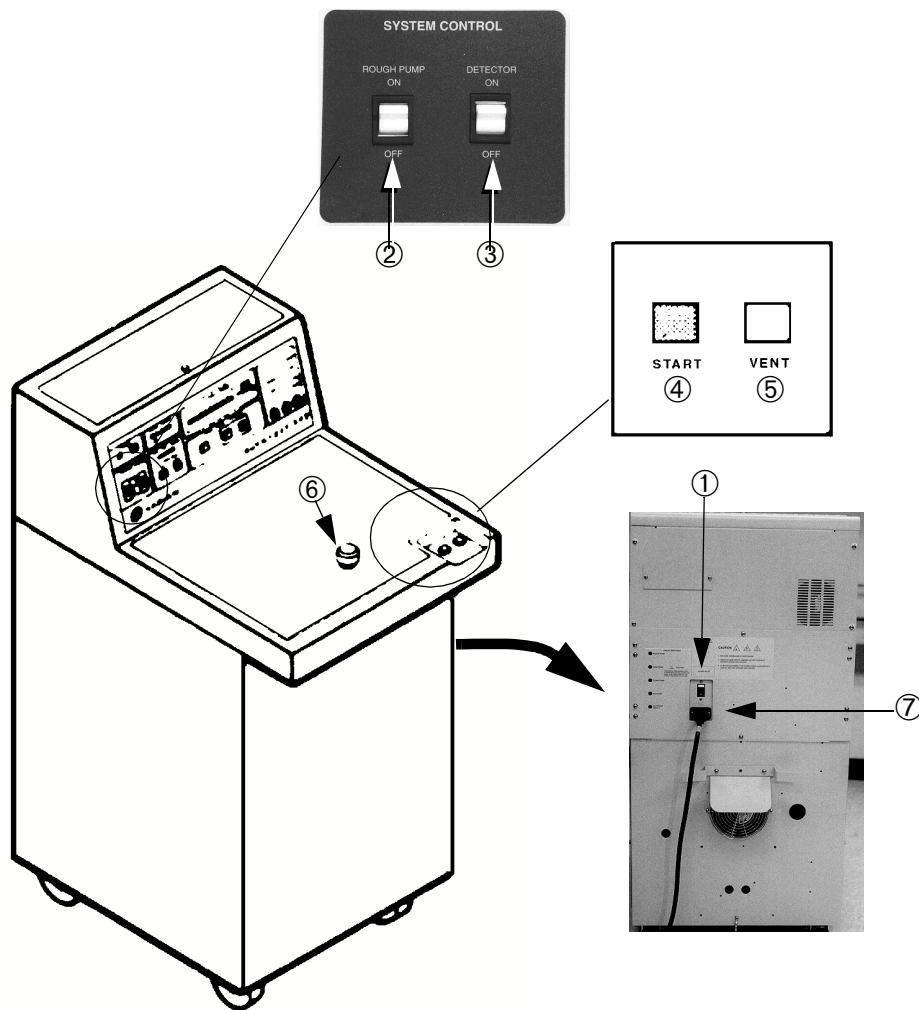

Figure 3-2 Start-Up Controls

- |                                |  |
|--------------------------------|--|
| ① Power switch/Circuit breaker | Main power switch and circuit breaker.   |
| ② Rough pump switch            | Powers the rough pump.   |
| ③ Detector switch              | Powers the backing pump and high vacuum pump.  |
| ④ START button                 | Starts the 947/948/960 testing routine. Press and hold for 1 second to engage.   |
| ⑤ VENT button                  | Opens the vent valve so test pieces can be removed or attached to the detector. Press and hold for 1 second to engage. |



*If the **VENT** button is pressed for less than one second, the leak detector moves to **HOLD**.*

- |                  |  |
|------------------|--|
| ⑥ ⑥ Test Port    | The unit under test is connected to this port using a test fixture, or a plug is inserted for storage. |
| ⑦ AC Power Input | View of back of unit.  |

Refer to Figure 3-2 and follow the start up procedure, listed in the next Section, and in Section 3.4, "Calibration and Sensitivity Checks" procedure to put the 947/948/960 in a *Ready for Operation* state from the *All Systems off* condition.

### 3.3.1 Startup Procedure

To perform the start-up procedure:

1. Locate the main power switch/circuit breaker ① on the back of the lower cabinet and turn it on.
2. Turn on the Rough ② pump switch.
3. Turn on the Detector ③ switch.
4. **Models 948/960 only:** When the system pressure bar graph drops into the green range (see Figure 1-3 on page 1-6), fill the cold trap with liquid nitrogen.



*Liquid nitrogen causes burns upon contact. Use appropriate protective devices, including heavy loose gloves and eye or face shields.*

Refill the cold trap as required to prevent it from thawing in the vacuum system. The trap needs to be filled approximately every 14 hours. Monitor the level and fill more often if necessary.

### CAUTION



*If the cold trap in the 948/960 is allowed to empty of liquid and thaw in the vacuum system, spectrometer tube contamination occurs resulting in unstable leak rate detection. Attempts to perform an automated calibration can also result in error conditions (codes c6, c7, and c8). Filling the trap completely keeps the trap operational up to 14 hours. Before refilling is required, refer to Section 4, "Maintenance" for the cold trap cleaning procedure.*

5. Wait 30 minutes for the 947/948/960 to warm up to operating temperature.
6. The detector is now on and ready for normal operation.

### NOTE



*Perform the calibration and sensitivity check before taking readings with the 947/948/960.*

## 3.4 Calibration and Sensitivity Checks

At the beginning of each workday or shift, or as conditions require, verify 947/948/960 integrity by performing the Calibration and Sensitivity Check procedure. Compliance with this procedure prepare your detector for normal daily operation. If the *NOT READY* LED comes on during calibration, refer to the condition code that appears in the leak rate exponent display shown in Figure 3-3.

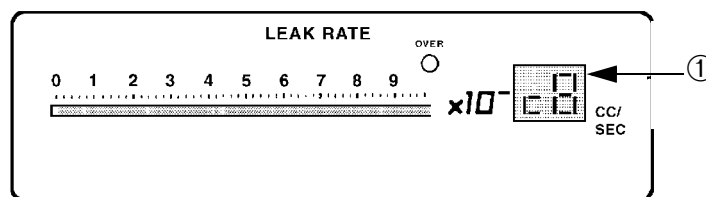

**Figure 3-3 Exponent Display with Condition Code Indicated**

- ① Condition Code                      Exponent area with condition code displayed.

## Models 947, 948 and 960 Leak Detectors Operations and Service Manual

Table 3-1 lists the Not Ready condition codes and the action to take to correct the error condition.

**Table 3-1 NOT READY Condition Codes**

Code	Problem	Solution
c0	Amplifier Offset is out of range	Notify Varian Vacuum Technologies Customer Service. Spectrometer Tube Amplifier needs service.
c2	Rough pump is off	Turn on the rough pump.
c4	No emission	Select the other ion source filament. Replace ion source if necessary. Refer to Section 4, "Maintenance".
c5	Auto calibrate function is out of range	Notify Varian Vacuum Technologies Customer Service. Leak detector requires maintenance.
c6	Auto tune function is out of range	Tap the AUTO CAL button. (A brief tap may clear this code to allow the leak detector to operate.) If this clears <b>c6</b> then the leak detector is operable. If <b>c5</b> appears with <b>c6</b> it is the priority condition code. Press <b>VENT</b> to clear. <b>NOTE:</b> A c6 condition code means that maintenance of the leak detector may soon be necessary. Notify Varian Vacuum Technologies Customer Service at 1-800-8VARIAN.
c7	Auto Zero function is out of range	Notify Varian Vacuum Technologies Customer Service. Leak detector requires maintenance.
c8	Power interruption	Perform a Calibration and Sensitivity Check. This condition code may be accompanied by an intermittent <b>c9</b> indication.
c9	System pressure is too high	Check for vacuum leaks. Refer to Section 4, "Maintenance".

### 3.4.1 Calibration and Sensitivity Checks

To perform calibration and sensitivity checks:

1. Warm up the 947/948/960 for 30 minutes.
2. Place the test port plug in the test port opening ⑥. Refer to Figure 3-2 on page 3-9.
3. Set the Transfer switch to **AUTO**.
4. Set the Mode switch to **AUTO**. The VENT LED should illuminate.

5. Press the **START** button.
  - The VENT LED goes off.
  - The START LED illuminates.
  - The TEST LED illuminates when test pressure drops.
  - The START LED goes off (1 second) after TEST LED illuminates.
  - The Leak Rate range display goes to most sensitive range.
6. Press the **ZERO** button. The ZERO LED turns on briefly.
7. Be sure the TEST LED is on, and press the **STD LEAK** button.

The STD LEAK LED illuminates and the LEAK RATE display should be equal to the internal calibrated leak as marked inside the hinged top cover.
8. Press **STD LEAK** again to turn it off and continue testing.

The LEAK RATE display should return to the most sensitive decade. If the leak rate reading is not within 20% of the number on the calibrated leak label, perform an AUTO CAL.
9. Be sure the TEST LED is on, and press the **AUTO CAL** button.

Do not continue if a condition code is displayed. Consult the *NOT READY* Condition Code Chart Table 3-1 on page 3-12 and follow instructions.

  - The STD LEAK LED is on; AUTO CAL is also on.
  - The LEAK RATE display mantissa and exponent values change as a function of auto tuning.
  - The STD LEAK LED goes off. The LEAK RATE display changes again and approximately 20 seconds later, the ZERO LED illuminates to signify the zero procedure is operating, then it goes off.
  - The AUTO CAL LED goes off, and the HOLD LED illuminates.
  - The LEAK RATE display mantissa is zero (one LED bar lit) on the most sensitive LEAK RATE range exponent.

Calibration is complete when the AUTO CAL LED goes out.
10. Recheck **STD LEAK** reading (Steps 7 and 8).
11. Press either the **START** or **VENT** button to continue operation following the AUTO CAL routine.

## 3.5 Operating Procedures

The testing parameters vary from one manufacturing environment to another. Appendix G, "Leak Detection Theory" describes the conditions under which the 947/948/960 Leak Detectors can be utilized. There are many applications. A Varian Vacuum Technologies representative is always available for technical assistance.

Whatever the leak detection situation, testing is accomplished in one of the two operating procedures:

- ❑ "Auto Ranging" below
- ❑ "Manual Ranging" on page 3-15

Requirements:

- ❑ After shutdown of a leak detector, a complete startup is necessary as outlined in Start-up Procedure.
- ❑ Verify the integrity of the leak detector with the Calibration and Sensitivity Checks Procedure on a daily basis or as necessary.

### 3.5.1 Auto Ranging

To use auto ranging for outside-in testing:

1. Press the **VENT** button. Securely attach the new unit under test to the test port while the 947/948/960 is in VENT mode.
  - ❑ The TEST LED goes off.
  - ❑ The VENT LED illuminates.
2. Select the **AUTO** (Figure 3-4) position of the AUTO/MAN MODE switch in the Leak Rate Range section.

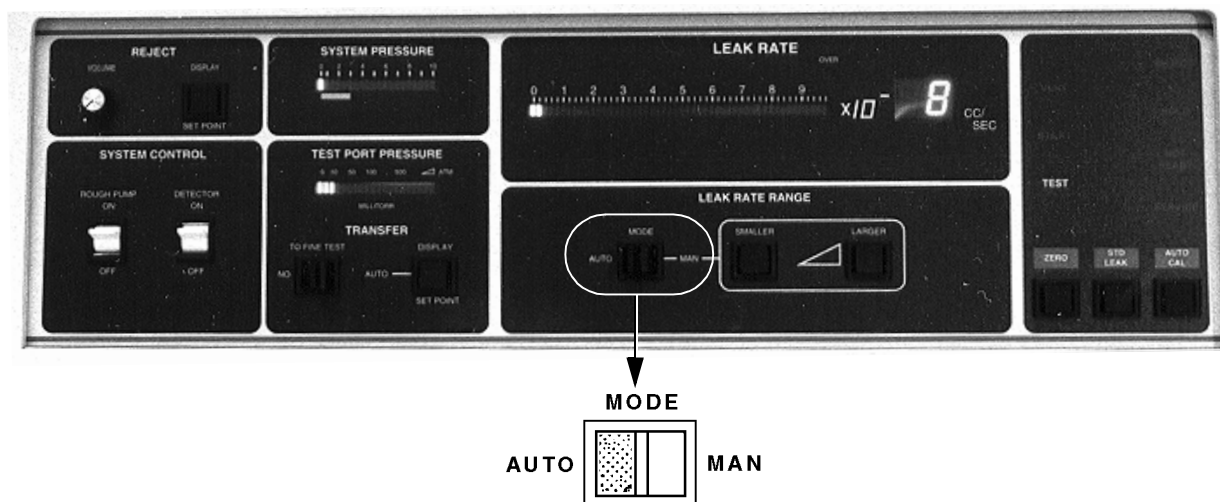

Figure 3-4 Location of AUTO/MAN MODE Switch

3. Press the **START** button.
  - The VENT LED goes off and one second later, the START LED illuminates.
  - The TEST LED illuminates.
  - The START LED goes out.
  - The LEAK RATE range exponent goes to the most appropriate range.
4. Introduce helium to the unit under test.

The 947/948/960 automatically traces the under test helium signal up range through the Reject Set Point. If larger than the pre-set Reject value, the leak rate signal reads this maximum level. The REJECT LED lights up.
5. Press and hold the **VENT** button approximately 1 second until the 947/948/960 is in VENT mode.
  - Test LED goes off.
  - Vent LED illuminates.
6. Remove the unit under test from the test port.
  - VENT LED is on.

Auto ranging procedure is complete.

### 3.5.2 Manual Ranging

Manual ranging is used when the range of the failure level for the part under test is known.

To range manually:

1. Press the **VENT** button.
  - TEST LED goes off.
  - VENT LED illuminates.
2. Select the **MAN** position of the AUTO/MAN MODE switch in the Leak Rate Range section.
3. Press the **SMALLER** or **LARGER** button to select the exponent of the leak rate range to which you want to test.
4. Securely attach the new unit under test to the test port while the 947/948/960 is in VENT mode.

5. Press the **START** button.
  - The VENT LED goes off.
  - The START and TEST LEDs illuminate a second later.
  - The START LED turns off and the LED Rate Range (exponent) displays at the selected range.
6. Introduce helium to the item under test. The leak detector automatically traces the helium signal within the selected range. If larger than the pre-set Reject value, the leak rate signal reads the maximum level and the Reject LED illuminates.
7. Press and hold the **VENT** button for approximately 1 second until the unit switches to the VENT mode.
  - The TEST LED turns off.
  - The VENT LED illuminates.

**NOTE**



*If the **VENT** button is pressed for less than one second, the leak detector moves to **HOLD**.*

8. Remove the tested part from the test port.

The Leak test is now complete.

### 3.6 Standby

When continued use of 947/948/960 is not anticipated, STANDBY mode, a partial shutdown, can be used to save energy. To put the 947/948/960 into STANDBY mode:

1. Press the **VENT** button and hold it until the Vent LED comes on.
2. Place the Rough pump power switch in the **OFF** position.
3. Turn the Rough pump switch breaker to the **ON** position to return the Leak Detector to the READY FOR OPERATION mode.

**NOTE**



*When the unit is returned to Ready for Operation from Standby, the warmup periods do not apply.*



### 3.7 Shutdown

Complete shutdown for a move or temporary storage is accomplished by the following shutdown procedure:

1. Place the test port plug securely in the test port.
2. Turn the ROUGH PUMP switch **OFF**.
3. Turn DETECTOR switch **OFF**.
4. Turn the Power switch/circuit breaker **OFF** on back of cabinet.
5. For the 948/960 only, empty the cold trap.

See Section 4.2.3, "Liquid Nitrogen Cold Trap (Models 948/960 only)" on page 4-10 for the cleaning procedure.

### 3.8 Using the Pendant for Parameter Setup

The service pendant is stored in the turret and is connected to Models 947/948/960 at J1 in the turret for parameter changes, monitoring, or diagnostics. The pendant must be connected to the 947/948/960 to operate any of the functions. Refer to Appendix G, "Leak Detection Theory" for information on turret connectors.

The service pendant is used to set up and monitor:

- Reject set point
- Crossover pressures
- Auto sequence parameters
- Ion Source parameters
- System setup parameters (such as the value of the calibrated leak).

When the pendant is powered by the 947/948/960, the display indicates the model to which the leak detector is connected. The keyboard is laid out in function keys and numeric keys. See Figure 3-5.

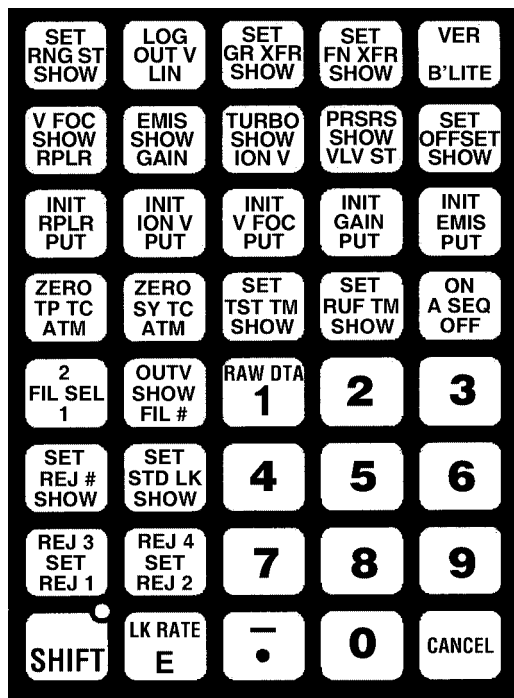

Figure 3-5 Service Pendant Keypad

Several parameters relating to the operation and performance of the 947/948/960 Platform are stored in EPROM. These parameters are viewed and changed via the service or rear serial ports. Some parameters are set when the system is assembled and tested. Other parameters should be changed when a gauge is changed or when the ion source or preamplifier is changed. Some parameters are changed automatically during power up, Auto Cal, or Auto Zero functions. See Appendix G, "Leak Detection Theory" for details.

### 3.9 Optional Discrete I/O

To use the optional discrete I/O connections, connect to J120 and J121 on the rear panel. Refer to Appendix D, "Inputs and Outputs" for detailed information.

When operating the 947/948/960 from the optional discrete I/O, it is necessary to make the PARALLEL ENABLE (J120 pin 6) active. This allows the leak detector to accept commands from the other discrete I/O inputs. Making PARALLEL ENABLE active also disallows any changes to the operating parameters through the serial port, the service pendant, or the front panel. Requests for changes made through the serial port would be responded to by **cant**.

## Betrieb

Um mit den Lecksuchern 947/948/960 genaue Werte zu erzielen, befolgen Sie die in diesem Abschnitt aufgeführten Betriebsverfahren. Die 947/948/960 messen die Leckrate in atm cc/Sek.

Die Verfahren erklären:

- Starten und Warmlaufen der 947/948/960.
- Kalibrieren der 947/948/960.
- Einstellen der Parameter, um genaue Werte zu erhalten.
- Bedienung der 947/948/960, um bei der Verwendung von Helium präzise Leckwerte zu erhalten.
- Einstellen der 947/948/960 auf den Bereitschaftsmodus und/oder vollständiges Abschalten der Maschinen zwecks Wartungsarbeiten oder Aufbewahrung.

Die Parametereinstellung unter Verwendung der Hängebedienungstafel bezieht sich sowohl auf den alleinstehenden Betrieb (manuell) als auch auf den Betrieb während der Fertigung.

### 3.10 LED-Anzeigen und Steuerelemente auf der Fronttafel

Abbildung 3-6 zeigt die LED-Anzeigen und Steuerelemente auf der Fronttafel (rechte Seite) des 947/948/960 Aufsatzes. Eine Definition der Tasten ist unter Abschnitt 1.12, "Anzeigen und Steuerelemente der Fronttafel" auf Seite 1-21 zu finden.

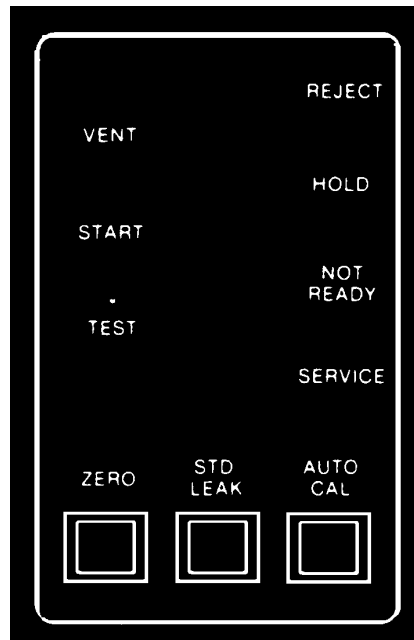

**Abbildung 3-6 LED-Anzeigen und Steuerelemente auf der Fronttafel**

Während des Betriebs leuchten die LED-Funktionen auf, um anzuzeigen, dass ein Vorgang stattfindet. Die Definition der Betriebsvorgänge ist wie folgt:

- |               |  |
|---------------|--|
| VENT (Ablass) | Leuchtet auf, wenn das Ablassventil geöffnet ist. Die LED leuchtet nicht auf, wenn das Ventil geschlossen ist.   |
| START         | Leuchtet auf, wenn die START-Taste gedrückt wird. Sie erlischt eine Sekunde nach Aufleuchten der TEST LED oder unmittelbar nach dem Aufleuchten der LED VENT, HOLD oder NOT READY.   |
| TEST          | Leuchtet auf, wenn sich die 947/948/960 im Testmodus befinden; entweder das Großeleckventil oder das Testventil ist geöffnet. Unter keinen anderen Bedingungen die leuchtet LED auf. |

ZERO (Null)	Leuchtet auf, wenn die Taste ZERO betätigt oder wenn im Rahmen der Kalibrierungssequenz die automatische Nullstellung durchgeführt wird. Die LED erlischt eine Sekunde nach Beendigung der automatischen Nullstellung oder wenn der Lecksucher seinen Bereitschaftszustand verlässt. Die LED ZERO blinkt auf, wenn das Signal unter Null abfällt. Während der Inbetriebnahme, wenn das System den Vorverstärker auf Null einstellt, blinkt die LED ZERO ebenfalls auf.
REJECT (Zurückweisen)	Leuchtet auf, wenn die Rückweisfunktion aktiv ist und wenn der Leckratenwert den ausgewählten Sollwert übersteigt. Sie erlischt, wenn die Leckrate unter den Sollwert abfällt.
HOLD (Halten)	Leuchtet auf, wenn die Maschine sich bei geschlossenen Prüf- und Grobventilen im Haltemodus befindet. Der Haltemodus wird durch kurzes Drücken der Taste VENT, wenn sich die Maschine im Modus TEST befindet, ausgewählt. Im Haltemodus wird durch Drücken der Tasten START oder VENT der nächste Betriebsvorgang ausgelöst.
NOT READY	Leuchtet immer dann auf, wenn die Betriebsbereitschaft verhindert ist. Der jeweilige Fehlercode (von c0 bis c9) erscheint auf der Bereichsanzeige. Für Informationen über die Fehlercodes siehe Table 3-2 on page 3-31.
AUTO CAL (automatische Kalibrierung)	Wenn sich der Lecksucher im Testmodus befindet, leuchtet diese LED auf, wenn die Taste AUTO Cal gedrückt wird. Dadurch werden alle anderen Drucktasten auf der Fronttafel, darunter START und VENT, deaktiviert. AUTO CAL ist nur dann aktiv, wenn sich der Lecksucher im Testmodus befindet. Nach Abschluss des automatischen Kalibrierungsverfahrens kehrt die Maschine in den Testmodus zurück.
STD LEAK (Standard-Leck)	Leuchtet auf, wenn das Standard-Lecksuchventil geöffnet ist. Dieser Zustand tritt während der automatischen Kalibrierung oder dann ein, wenn die Taste STD LEAK gedrückt wird. Sie erlischt, wenn das Standard-Lecksuchventil durch Drücken der Taste STD LEAK geschlossen wird.
SERVICE (Wartung)	Nicht benutzt.

### 3.11 Erste Einstellung der Systemparameter

Die 947/948/960 führen Funktionen und Prüfungen durch, die auf Parameterwerten beruhen. Einige Parameter werden beim Aufstellen und Prüfen des Systems eingegeben und eingestellt. Einige Parameter werden während der Inbetriebnahme, Kalibrierung oder Nullstellung berechnet und automatisch geändert. Andere Parameter werden geändert, wenn eine Änderung am System selbst vorgenommen wird, z.B. wenn ein Thermoelement-Prüfgerät, die Ionenquelle oder der Vorverstärker ausgewechselt wird. Diese Parameter werden als eine Funktion der physikalischen Konfigurations- und Empfindlichkeitsanforderungen eingestellt.

Mehrere Parameter, die sich auf den Betrieb und die Leistung der Maschine auswirken, werden auf dem EPROM in der Steuereinheit gespeichert. Die Informationen für diese Parameter gehen beim Ausschalten der Maschine nicht verloren. Parameter können durch Eingabe von Befehlen auf der Hängebedienungs- oder auf dem Hostrechner eingesehen oder geändert werden.

Eine Erklärung der Parameter und der Ausführung der jeweiligen Funktionen ist Abschnitt 3.11.1, "Parameter und Betriebsmod" auf Seite 3-22 zu entnehmen.

#### 3.11.1 Parameter und Betriebsmod

Parameter und Betriebsmodi sind zur Durchführung der Lecksuche aufeinander angewiesen; die eingegebenen Parameter bestimmen die Art der durchgeführten Prüfung und die Prüfeempfindlichkeit. Die nachstehende Liste enthält eine Erklärung der Parameter und Funktionen. Für zusätzliche Informationen über die Einstellung von Parametern oder Auswahl einer Funktion siehe Abschnitt 3.12, "Inbetriebnahme" auf Seite 3-28 und Appendix A, "Service Pendant Keypad Functions", oder bei installierter Schnittstelle an der optionalen rückseitigen Schalttafel auch Appendix C, "Communications Protocol".

RANGE (Bereich)	Die 947/948/960 stellen den Bereich entsprechend dem Exponenten des unempfindlichsten Bereichs des Lecksuchers automatisch ein, je nach der Empfindlichkeit des Vakuumsystems.
-----------------	--

AUTO-RANGE (automatischer Bereich) und MANUAL RANGE (manueller Bereich)	Bei einer automatischen Bereichseinstellung ändern sich der Leckratenexponent und der Modus des Lecksuchers automatisch, sodass der Leckratenwert nicht von der Skala abweicht.
--	---

Der manuelle Bereich dient dazu, die 947/948/960 zu einer Anzeige der Leckrate in nur einer Dekade zu zwingen (der Exponent ändert sich nie). Diese Funktion erweist sich dann als nützlich, wenn der Bediener nur darauf bedacht ist, die Leckratenmessung in einer einzigen Dekade zu überwachen. Stellen Sie den Bereichsmodus für die Leckrate auf MAN und benutzen Sie die Tasten KLEINER oder GRÖßER, um den Bereich zu ändern.

### RANGE STOP

Mit der Funktion RANGE STOP werden die 947/948/960 so konfiguriert, dass ihr Bereich automatisch nur bis zur vorab ausgewählten Dekade, die im Variablenfeld für "Bereich Stopp" eingegeben wurde, eingestellt wird. Wenn zum Beispiel RANGE STOP aktiviert und auf -07 eingestellt ist, ist  $10^{-7}$  der empfindlichste Bereich, den der Lecksucher anzeigen kann.

Diese Funktion erweist sich dann als nützlich, wenn eine Produktspezifikation um mehr als eine Dekade weniger stringent ist als die Empfindlichkeit des Lecksuchsystems in seiner jeweiligen Konfiguration. Kann das konfigurierte System  $10^{-9}$  atm cc/Sek. erfassen und liegt die Testspezifikation nur im Bereich  $10^{-7}$  atm cc/Sek., wird durch Einstellen des RANGE STOP auf -08 die Dauer des Prüfzyklus reduziert, da es nicht erforderlich ist, dass der Lecksucher während jedes Prüfzyklus seine empfindlichste Dekade ( $10^{-9}$ ) erreicht.

### AUTO CAL (automatische Kalibrierung)

Diese Funktion dient zur automatischen Kalibrierung auf der Grundlage der eingestellten Parameter. Die Kalibrierung wird mit einem bekannten internen Leck verglichen.

Drücken Sie zur Durchführung einer automatischen Kalibrierung die Taste AUTO CAL oder bestätigen Sie die Kalibrierungseingabe über den seriellen Port oder den optionalen diskreten E/A.

### CALIBRATED LEAK VALUE (kalibrierter Leckwert)

Die 947/948/960 werden ab Werk mit einem kalibrierten Leck versandt. Der Wert ist auf dem Aufsatz des Lecksuchers und auf dem Kalibrierungsleck-Zertifikat vermerkt. Bei der Durchführung einer Kalibrierung vergleicht das System das Leckratensignal mit dem gespeicherten Wert. Während des Einstellverfahrens werden die Spannung der Ionenquellenkammer und die variable Fokusspannung unabhängig gescannt und die einzelnen Werte für ein maximales Heliumsignal optimiert. Nach Abschluss des Einstellverfahrens wird die Systemverstärkung justiert, um die Kalibrierung des Lecksuchers zu wahren.

### ZERO (Null)

Die Funktion ZERO liest das Hintergrund-Leckratensignal, speichert den Wert und stellt dann den Nullbezugspunkt zurück. Anschließende tatsächliche Prüfmessungen schließen sowohl Helium vom echten Leck als auch Helium von Hintergrundbedingungen ein, das verzeichnete Hintergrundsignal von der Messung wird jedoch subtrahiert und die sich daraus ergebende echte Leckrate wird angezeigt. Drücken Sie zur Durchführung einer Nullstellung die Taste ZERO oder bestätigen Sie die ZERO-Eingabe über den seriellen Port oder den optionalen diskreten E/A.

#### HINWEIS



*Die Durchführung der Nullstellungsfunktion bei gleichzeitiger Zuführung von Helium zum Prüfobjekt kann eine Unterdrückung des echten Lecks zur Folge haben. Benutzen Sie die Nullstellungsfunktion nur nach Entfernen der Heliumquelle.*

### REJECT SET POINTS (Rückweisungs-Sollwerte)

Die REJECT SET POINTS dienen dazu, den Bediener darauf aufmerksam zu machen, dass die gemessene Leckrate den Sollwert überschritten hat. Es stehen vier Sollwerte zur Verfügung. Jeder Sollwert muss aktiviert werden, bevor er betriebsfähig ist. Ebenso muss er deaktiviert werden, um seinen Betrieb anzuhalten. Es kann nur jeweils ein Sollwert aktiv sein.

### AUDIO VOLUME (Lautstärke)

Die Lautstärkenregelung dient zur Aktivierung des Audiotons vom Aufsatz. Die Audiotonfrequenz steigert sich mit zunehmender Größe des gemessenen Lecks. Die Lautstärkenregelung befindet sich am Aufsatz.

### BAR GRAPH DISPLAY (Balkendiagramm-Anzeige)

Die auf der Fronttafel vorgesehene Balkendiagramm-Anzeige mit 50 Unterteilungen gibt den Mantissenwert für die Leckrate von 0 bis 10 wieder. Die Skala befindet sich über dem Balkendiagramm. Die numerische Anzeige rechts neben dem Balkendiagramm zeigt den Leckraten-Exponentenwert in atm cc/Sek an.

### LINEAR VS LOG OUTPUT (linearer/logarithmischer Ausgang)

Konfigurieren Sie die analoge Ausgangsspannung zum optionalen E/A-Port an der Rückseite der Einheit. Die Optionen für den Ausgang sind linear oder logarithmisch mit 2 VDC je Dekade oder 3 VDC je Dekade.



AUTO-SEQUENCER  
(automatische  
Ablaufsteuerung)

Diese Funktion generiert Annahme-/Rückweisungssignale und ermöglicht die Programmierung von Grob-, Prüf- und Zykluszeiten. Die automatische Ablaufsteuerung ermöglicht die Einstellung der 947/948/960, sodass sie automatisch einen kompletten Prüfzyklus (START/ROUGH/TEST/VENT) durchlaufen und den jeweiligen Teil der Prüfung je nach den vom Benutzer eingegebenen Prüfspezifikationen annehmen oder abweisen. Die Einstellung der automatischen Ablaufsteuerung bestimmt die Grobzeit, die Prüfzeit und das Ein/Aus der automatischen Ablaufsteuerung für das Prüfobjekt. Ein Annahme- oder Rückweisungszustand wird aufgrund des vom Benutzer ausgewählten Rückweisungs-Sollwertes und/oder des Erreichens der Druckübertragungs-Sollwerte innerhalb der für die Grobzeit festgelegten Zeitdauer bestimmt.

Der Annahme- oder Rückweisungs-Leckratenwert der automatischen Ablaufsteuerung wird über den Rückweisungs-Sollwert ausgewählt. Die Annahme-/Rückweisungskriterien beruhen auf dem Rückweisungs-Sollwert, der gerade aktiv (eingeschaltet) ist. Wurden mehrere Sollwerte aktiviert, beruhen die Annahme-/Rückweisungskriterien auf dem strengsten Rückweisungs-Sollwert.

Ein Annahmezustand wird dadurch angezeigt, dass das System nach Abschluss des Prüfzyklus wieder zum Ablassmodus (VENT) zurückkehrt. Ein Rückweisungszustand führt dazu, dass auf dem LED-Anzeigefeld REJECT erscheint und nach Abschluss des Prüfzyklus der Rückweisungs-Sollwert aktiviert wird. Ein Rückweisungszustand wird auch dadurch angezeigt, dass das System in den Haltemodus zurückkehrt und alle Betriebstasten mit Ausnahme von VENT deaktiviert werden. Der Status der Rückweisungs-Sollwerte ist am optionalen E/A-Kommunikationsport (Host rechner) und durch Abfrage der Hängedienungstafel verfügbar (Anhang A, "Service Pendant Keypad Functions").

Nach Abschluss eines automatischen Prüfzyklus erfassen die 947/948/960 das Leckratensignal, das unmittelbar vor Ablauf des automatischen Prüfzyklus gemessen wurde. Diese Leckrate wird angezeigt und am Kommunikationsport des analogen Ausgangs gesichert, bis der nächste Prüfzyklus initiiert wird. Auf diese Weise erhält der Benutzer die Gelegenheit, den aktuellen Leckratenwert für das jeweilige Prüfobjekt aufzuzeichnen.

ROUGH TIME (Grobzeit)	<p>Die Variable ROUGH TIME bestimmt die Zeitdauer, die dem Lecksucher für die Evakuierung des Prüfobjekts zum annehmbaren Prüfübertragungsdruck zugemessen wird. Im automatischen Ablaufsteuerungsmodus beginnen die 947/948/960 die Prüfung, sobald der annehmbare Prüfübertragungsdruck erreicht wird. Sie warten nicht, bis die gesamte Grobzeit abgelaufen ist, wenn dies nicht erforderlich ist. Wird der annehmbare Prüfübertragungsdruck nicht in der vorab ausgewählten Grobzeit erzielt, bricht das System den Zyklus ab und geht auf den Haltemodus über.</p> <p>Der Wert für die ROUGH TIME kann empirisch festgelegt werden und sollte der typischen Zeitdauer entsprechen, die für eine grobe Einstellung des Prüfobjekts auf einen annehmbaren Prüfdruck erforderlich ist. Wird der annehmbare Prüfdruck nicht innerhalb der vorab ausgewählten Grobzeit erreicht, ist dies ein Anzeichen für ein Großleck im Prüfobjekt oder im Prüfanschluss oder dafür, dass die zugemessene Zeit unzureichend war.</p>
TEST TIME (Prüfzeit)	<p>Die Prüfzeit-Variable bestimmt die Zeitdauer, für die sich der Lecksucher im Prüfmodus befindet, bevor die gemessene Leckrate mit dem vorab ausgewählten Rückweisungs-Sollwert verglichen wird. Die zugemessene Zeit muss ausreichen, um eine Stabilisierung des Leckratenwerts zu ermöglichen, bevor das System seine Entscheidung über eine Annahme-/Rückweisung trifft. Dies ist eine Funktion der Teilkonfiguration und der Leckratenspezifikation. Bei der automatischen Ablaufsteuerung bleiben die 947/948/960 während der ganzen Dauer der ausgewählten Prüfzeit im Prüfmodus.</p>
FINE TEST MODE (Feinprüfmodus)	<p>Bei einer Verwendung des Feinprüfmodus (normaler Betriebsmodus) prüft der Lecksucher automatisch auf Großlecks und geht dann, wenn keine Großlecks erfasst wurden, auf den Feinprüfmodus über.</p>

GROSS TEST ONLY  
(nur Grobprüfung)  
HOLDING IN GROSS FOR  
LARGE LEAKS  
(Grobtestposition für große  
Lecks wird gehalten)

Die Lecksucher 947/948/960 benutzen das Contra-Flow-System, das über ein Grobleckmanifold verfügt und eine Prüfung bei höherem Eingangsdruck und reduzierter Empfindlichkeit zulässt.

Ist TRANSFER TO FINE TEST auf NO eingestellt, schaltet der Lecksucher nicht auf den Feinprüfmodus um. Diese Funktion erweist sich zum Qualifizieren von Teilen als nützlich, die vor der Feinprüfung ein ungewöhnlich hohes Maß an Grobleck-Rückweisungen aufweisen.

TRANSFER POINTS  
(Übertragungswerte)

Zur Einstellung der Prüfübertragungsdruckwerte für die verschiedenen Prüfmodi.

Die Übertragungsdruck-Einstellungen können für spezifische Anwendungen auf niedrigere Werte geändert werden. Die 947/948/960 verfügen über vorprogrammierte Übertragungsdruck-Höchstwerte, die leicht über den Vorgabewerten liegen. Diese Grenzwerte verhindern, dass der Bediener die 947/948/960 versehentlich so einstellt, dass sie bei zu hohem Druck auf den Prüfmodus übergehen, was zu einer übermäßigen Kontamination des Spektrometerrohrs oder einem Versagen des Ionenquellen-Glühfadens führen kann.

GROSS LEAK XFER  
(Grobleckübertragung)

Der Sollwert GROSS LEAK XFER bestimmt den Crossover-Wert des Prüfdrucks, bei dem die 947/948/960 auf den Grobleckprüfmodus übergehen. Im Grobleckprüfmodus wird der Großteil des geprüften Gases über eine zweckbestimmte Grobvakuumpumpe abgepumpt, während eine kleine Gasmenge durch ein Drosselventil in den Lecksucher geführt wird.

## 3.12 Inbetriebnahme

Für den Betrieb der 947/948/960 benötigen Sie:

- Prüfanschlüsse für die zu prüfende Einheit
- Heliumtank mit Spritzpistole oder Anschluss für automatische Prüfung (Helium für 948/960)

Abbildung 3-7 zeigt die wichtigen Steuerelemente der 947/948/960 für Inbetriebnahmen und Netzanschluss. Für Einzelheiten über den Trennschalter siehe Abschnitt 1.14, "Rückseitige Schalttafelstromanschluss und Trennschalter" auf Seite 1-25.



Abbildung 3-7 Steuerelemente zur Inbetriebnahme

- |                                   |   |
|-----------------------------------|---|
| ① Netzschalter /<br>Trennschalter | Netzstrom- und Trennschalter  |
| ② Schalter für<br>Grobvakuumpumpe | Zum Ein-/Ausschalten der Grobvakuumpumpe  |
| ③ Lecksucher-Schalter             | Zum Ein-/Ausschalten der Vorvakuum- und<br>Hochvakuumpumpe  |
| ④ START-Taste                     | Startet das Prüfverfahren der 947/948/960. Drücken Sie<br>diese Taste und halten Sie sie eine Sekunde lang nieder, um<br>das Verfahren zu aktivieren.   |
| ⑤ VENT-Taste                      | Öffnet das Ablassventil, damit die Prüfteile vom Lecksucher<br>entfernt oder am Lecksucher angebracht werden können.<br>Drücken Sie diese Taste und halten Sie sie eine Sekunde<br>lang nieder, um das Verfahren zu aktivieren. |

### HINWEIS

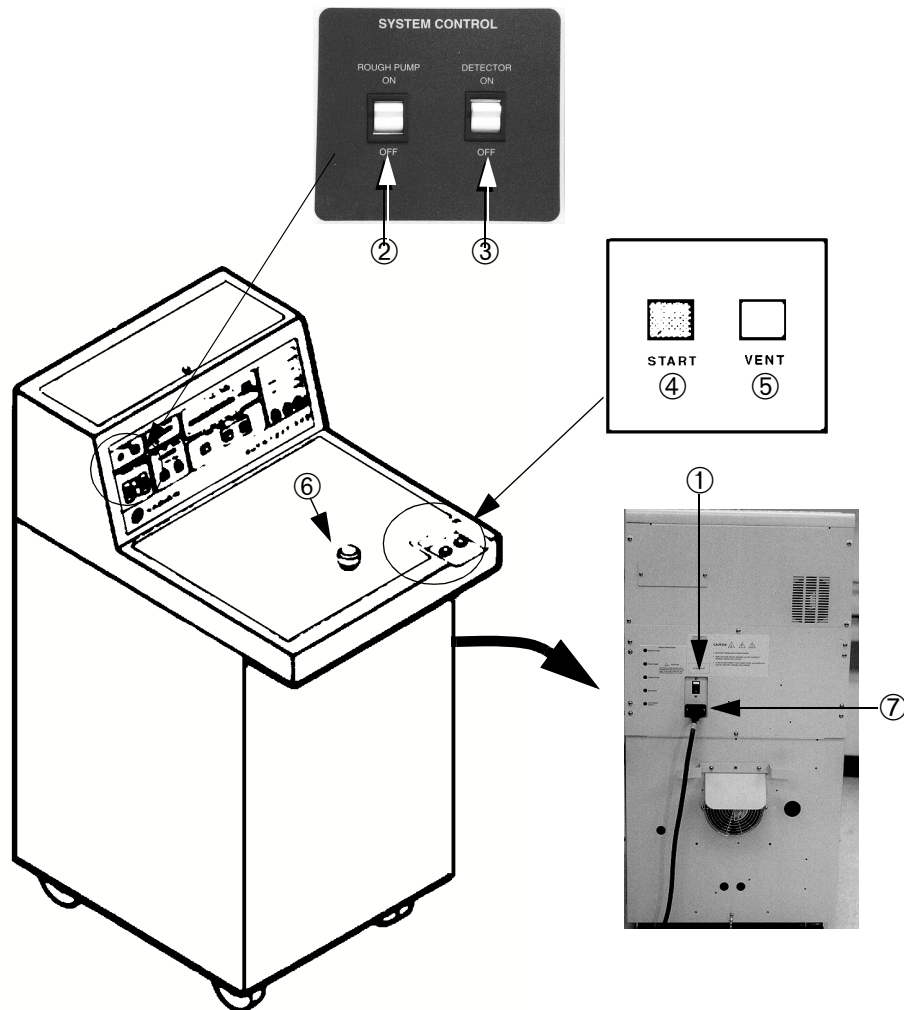

*Wird die Taste **VENT** nicht eine Sekunde lang gedrückt,  
geht der Lecksucher auf **HOLD** über.*

- |                  |   |
|------------------|---|
| ⑥ Prüfport       | Die zu prüfende Einheit ist mittels einer Prüfvorrichtung an<br>diesen Port angeschlossen; bei der Aufbewahrung wird hier<br>ein Blindstecker eingesetzt. |
| ⑦ AC-Netzeingang | Ansicht der Rückseite der Einheit.  |

Nehmen Sie Bezug auf Abbildung 3-7 und befolgen Sie die im folgenden Abschnitt aufgeführten Anleitungen zur Inbetriebnahme wie auch die Anleitungen unter Abschnitt 3.13, "Kalibrierungs- und Empfindlichkeitsprüfungen" auf Seite 3-31 um die 947/948/960 vom Zustand *Alle Systeme ausgeschaltet* in einen *betriebsbereiten* Zustand zu versetzen.

### 3.12.1 Anleitungen zur Inbetriebnahme

Gehen Sie bei der Inbetriebnahme wie folgt vor:

1. Identifizieren Sie den Netzstrom-/Trennschalter ① an der Rückseite des unteren Schrankes und stellen Sie ihn auf Ein.
2. Stellen Sie den Schalter für die Grobvakuumpumpe ② auf Ein.
3. Stellen Sie den Lecksucher-Schalter ③ auf Ein.
4. **Nur Modelle 948/960:** Wenn das Balkendiagramm für den Systemdruck nicht in den grünen Bereich fällt (siehe Abbildung 1-10 on page 1-21 ), füllen Sie die Kühlfalle mit Flüssigstickstoff.

#### WARNUNG



*Flüssigstickstoff verursacht Verbrennungen durch Berührung. Benutzen Sie angemessene Schutzvorrichtungen, einschließlich schwere, lockere Handschuhe sowie Augen- oder Gesichtsschutz.*

Füllen Sie die Kühlfalle je nach Bedarf auf, um zu verhindern, dass sie im Vakuumsystem auftaut. Im Durchschnitt muss die Falle alle 14 Stunden aufgefüllt werden. Überwachen Sie den Füllstand und geben Sie bei Bedarf häufiger Flüssigstickstoff hinzu.

#### VORSICHT



*Enthält die Kühlfalle in den 948/960 keine Flüssigkeit mehr und ist das Vakuumsystem abgetaut, erfolgt eine Kontamination des Spektrometerrohrs, was wiederum zu einer instabilen Leckratenerfassung führt. Wird dann versucht, eine automatische Kalibrierung durchzuführen, kann auch ein Fehlerzustand auftreten (Codes c6, c7 und c8). Wird die Falle bis zum Rand aufgefüllt, ist sie bis zu 14 Stunden lang betriebsbereit. Nehmen Sie vor dem Nachfüllen Bezug auf Abschnitt 4, "Maintenance" wo das Reinigungsverfahren für die Kühlfalle beschrieben wird.*

5. Warten Sie 30 Minuten, bis die 947/948/960 ihre Betriebstemperatur erreicht haben.
6. Der Lecksucher ist nun eingeschaltet und für den Normalbetrieb einsatzbereit.

#### HINWEIS



*Führen Sie eine Kalibrierungs- und Empfindlichkeitsprüfung vor, bevor Sie mit den 947/948/960 Messungen vornehmen.*

### 3.13 Kalibrierungs- und Empfindlichkeitsprüfungen

Verifizieren Sie zu Beginn jedes Arbeitstages oder jeder Schicht oder je nach Bedingungen die Integrität der 947/948/960, indem Sie eine Kalibrierungs- und Empfindlichkeitsprüfung vornehmen. Eine Einhaltung dieser Vorgehensweise bereiten Ihren Lecksucher auf den normalen täglichen Betrieb vor. Leuchtet während der Kalibrierung die LED *NOT READY* auf, nehmen Sie auf den Zustandscode Bezug, der auf der Leckratenexponentenanzeige unter Abbildung 3-8 angezeigt wird.



Abbildung 3-8 Exponentenanzeige mit angegebenem Zustandscode

① Zustandscode Exponentenbereich mit angezeigtem Zustandscode

Table 3-2 zeigt eine Liste von Zustandscodes für das nicht betriebsbereite System und zur Behebung des Fehlerzustandes erforderliche Maßnahmen an.

Tablelle 3-2 *Zustandscodes für nicht betriebsbereites System*

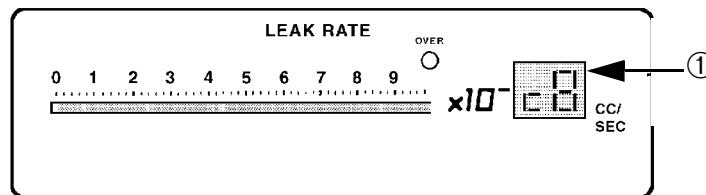
Code	Problem	Lösung
c0	Verstärker-Offset liegt außerhalb des Bereichs	Setzen Sie sich mit dem Kundendienst von Varian Vacuum Technologies in Verbindung. Der Spektrometerrohr-Verstärker muss gewartet werden.
c2	Grobovakuumpumpe ist ausgeschaltet	Schalten Sie die Grobovakuumpumpe ein.
c4	Keine Emission	Wählen Sie einen anderen Ionenquellen-Glühfaden aus. Bei Bedarf muss die Ionenquelle ersetzt werden. Siehe Abschnitt 4, "Maintenance".
c5	Automatische Kalibrierung liegt außerhalb des Bereichs	Setzen Sie sich mit dem Kundendienst von Varian Vacuum Technologies in Verbindung. Der Lecksucher muss gewartet werden.

Table 3-2 Zustandscodes für nicht betriebsbereites System

Code	Problem	Lösung
c6	Automatische Feineinstellung liegt außerhalb des Bereichs	Klopfen Sie leicht auf die AUTO CAL Taste. (Ein kurzes Klopfen kann diesen Fehlerzustand beheben und den Betrieb des Lecksuchers ermöglichen.) Wird der Fehlerzustand <b>c6 dadurch behoben</b> , ist der Lecksucher einsatzbereit. Erscheint <b>c5</b> mit <b>c6</b> handelt es sich um den Prioritätszustandscode. Drücken Sie <b>VENT</b> , um den Zustand zu beheben.  <b>HINWEIS:</b> Ein c6 Zustandscode bedeutet, dass in Kürze eine Wartung des Lecksuchers erforderlich ist. Wenden sie sich unter der Nummer 1-800-8VARIAN an den Kundendienst von Varian Vacuum Technologies .
c7	Automatische Nulleinstellung liegt außerhalb des Bereichs	Setzen Sie sich mit dem Kundendienst von Varian Vacuum Technologies in Verbindung. Der Lecksucher muss gewartet werden.
c8	Stromunterbrechung	Führen Sie eine Kalibrierungs- und Empfindlichkeitsprüfung durch. Bei diesem Zustandscode wird evtl. intermittierend <b>c9</b> angezeigt.
c9	Systemdruck ist zu hoch	Untersuchen Sie das System auf Vakuumlecks. Siehe Abschnitt 4, "Maintenance".

### 3.13.1 Kalibrierungs- und Empfindlichkeitsprüfungen

Gehen Sie bei der Durchführung von Kalibrierungs- und Empfindlichkeitsprüfungen wie folgt vor:

1. Lassen Sie die 947/948/960 30 Minuten lang warmlaufen.
2. Setzen Sie den Prüfportstecker in die Prüfportbuchse ein ⑥. Siehe Abbildung 3-7 on page 3-28.
3. Stellen Sie den Übertragungsschalter auf **AUTO**.
4. Stellen Sie den Modusschalter auf **AUTO**. Jetzt muss die LED VENT aufleuchten.



5. Drücken Sie die Taste **START**.
  - Die LED VENT erlischt.
  - Die LED START leuchtet auf.
  - Die LED TEST leuchtet auf, wenn der Prüfdruck abfällt.
  - Die LED START erlischt (1 Sekunde) nach Aufleuchten der LED TEST.
  - Die Leckratenbereichsanzeige begibt sich zum empfindlichsten Bereich.
6. Drücken Sie die Taste **ZERO**. Die LED ZERO leuchtet kurz auf.
7. Vergewissern Sie sich, dass die LED TEST aufleuchtet, und drücken Sie dann die Taste **STD LEAK**.

Die LED STD LEAK leuchtet auf und die Anzeige LEAK RATE muss dem intern kalibrierten, auf der Innenseite der oberen Klappabdeckung verzeichneten Leck entsprechen.
8. Drücken Sie nochmals **STD LEAK**, um die Funktion auszuschalten, und setzen Sie das Prüfverfahren fort.

Die Anzeige LEAK RATE kehrt nun zur empfindlichsten Dekade zurück. Liegt die angezeigte Leckrate nicht in einem Bereich von 20% der Zahl auf dem Schild für das kalibrierte Leck, führen Sie eine AUTO CAL durch.
9. Vergewissern Sie sich, dass die LED TEST aufleuchtet, und drücken Sie die Taste **AUTO CAL**.

Fahren Sie nicht fort, wenn ein Zustandscode angezeigt wird. Siehe die Zustandcodetabelle *NOT READY* Table 3-2 on page 3-31 und befolgen Sie die Anleitungen.

  - Die LED STD LEAK und die LED AUTO CAL leuchten auf.
  - Die Anzeigemantissen- und Exponentenwerte der LEAK RATE ändern sich im Rahmen der automatischen Einstellung.
  - Die LED STD LEAK erlischt. Die Anzeige LEAK RATE ändert sich erneut und etwa 20 Sekunden später leuchtet die LED ZERO auf, um anzuzeigen, dass die Nullstellung stattfindet. Dann erlischt die LED.
  - Die LED AUTO CAL erlischt und die LED HOLD leuchtet auf.
  - Beim empfindlichsten Exponenten des Bereichs LEAK RATE beträgt die Leckratenanzeigemantisse Null (ein LED-Balken leuchtet auf).

Die Kalibrierung ist abgeschlossen, wenn die LED AUTO CAL erlischt.
10. Überprüfen Sie nochmals die **STD LEAK** Werte (Schritte 7 und 8).
11. Drücken Sie entweder die Taste **START** oder die Taste **VENT**, um den Betrieb im Anschluss an das AUTO CAL Verfahren fortzusetzen.

### 3.14 Betriebsverfahren

Die Prüfparameter sind von Fertigungsumgebung zu Fertigungsumgebung verschieden. Anhang G, "Leak Detection Theory" beschreibt die Bedingungen, unter denen die Lecksucher 947/948/960 eingesetzt werden können. Es gibt zahlreiche Anwendungsbereiche. Zur technischen steht Ihnen immer ein Vertreter von Varian Vacuum Technologies zur Verfügung.

Je nach der Lecksuchsituation wird eine Prüfung nach einem der beiden folgenden Betriebsverfahren vorgenommen:

- Abschnitt 3.14.1, "Automatische Bereichseinstellung" auf Seite 3-34
- Abschnitt 3.14.2, "Manuelle Bereichseinstellung" auf Seite 3-36

Anforderungen:

- Nach Abschalten eines Lecksuchers ist eine vollständige Inbetriebnahme erforderlich, wie unter "Anleitungen zur Inbetriebnahme" beschrieben.
- Verifizieren Sie täglich oder je nach Bedarf die Integrität des Lecksuchers anhand der Kalibrierungs- und Empfindlichkeitsprüfungen.

#### 3.14.1 Automatische Bereichseinstellung

Automatische Bereichseinstellung für Outside-In-Prüfungen:

1. Drücken Sie die Taste **VENT**. Schließen Sie die neue Einheit, die geprüft werden soll, sicher am Prüfport an, während die 947/948/960 sich im Modus VENT befinden.
  - Die LED TEST erlischt.
  - Die LED VENT leuchtet auf.
2. Wählen Sie auf dem Schalter AUTO/MAN MODE die Position **AUTO** (Abbildung 3-9) im Bereich "Leak Rate Range" aus.

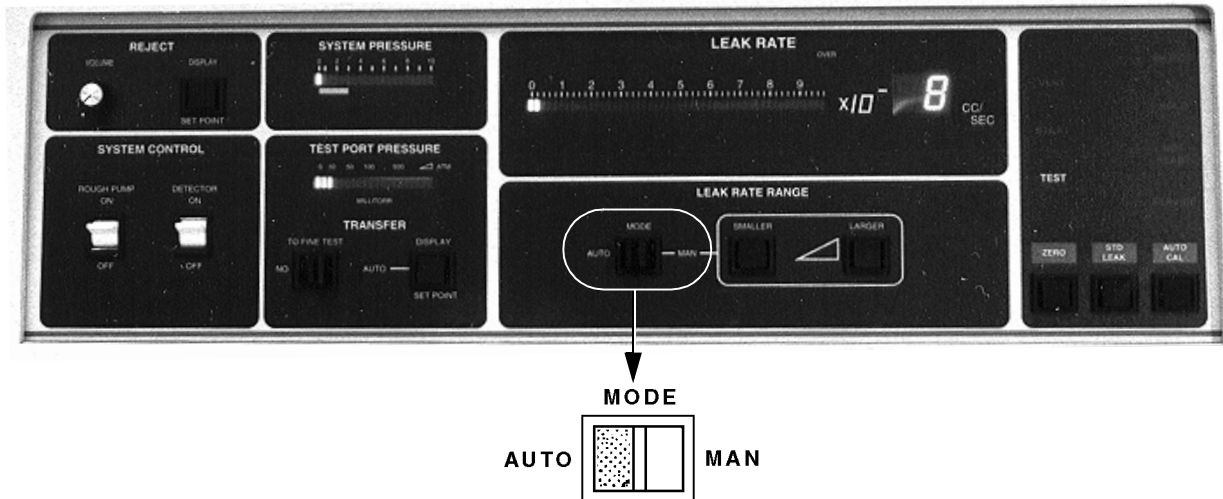

**Abbildung 3-9 Position des Schalters AUTO/MAN MODE**

3. Drücken Sie die Taste **START**.
  - Die LED VENT erlischt und eine Sekunde später leuchtet die LED START auf.
  - Die LED TEST leuchtet auf.
  - Die LED START erlischt.
  - Der Leckratenbereichsexponent begibt sich in den geeignetsten Bereich.
4. Führen die der Einheit, die geprüft wird, Helium zu.
 

Die 947/948/960 verfolgen das Prüfhelium beim Aufstieg durch den Bereich automatisch anhand des Rückweisungs-Sollwerts. Sollte es den vorgegebenen Rückweisungswert übersteigen, zeigt das Leckratensignal den Höchststand an. Die LED REJECT leuchtet auf.
5. Drücken Sie die Taste **VENT** und halten Sie diese ca. 1 Sekunde lang nieder, bis sich die 947/948/960 im Modus VENT befinden.
  - Die LED TEST erlischt.
  - Die LED VENT leuchtet auf.
6. Trennen Sie die Einheit, die geprüft wird, vom Prüfport.
  - Die LED VENT leuchtet auf.

Das Verfahren zur automatischen Bereichseinstellung ist nun abgeschlossen..

### 3.14.2 Manuelle Bereichseinstellung

Die manuelle Bereichseinstellung wird dann benutzt, wenn der Fehlerbereich des Teils, das geprüft wird, bekannt ist.

Gehen Sie bei der manuellen Bereichseinstellung wie folgt vor:

1. Drücken Sie die Taste **VENT**.
  - Die LED TEST erlischt.
  - Die LED VENT leuchtet auf.
2. Wählen Sie auf dem Schalter AUTO/MAN MODE die Position **MAN** im Bereich "Leak Rate Range" aus.
3. Drücken Sie die Taste **KLEINER** oder **GRÖßER**, um den Exponenten des Leckratenbereichs, den Sie prüfen möchten, auszuwählen.
4. Schließen Sie die neue Einheit, die geprüft werden soll, sicher am Prüfport an, während die 947/948/960 sich im Modus VENT befinden.
5. Drücken Sie die Taste **START**.
  - Die LED VENT erlischt.
  - Eine Sekunde später leuchten die LED START und TEST auf.
  - Die LED START erlischt und die LED RATE RANGE (Exponent) zeigt den ausgewählten Bereich an.
6. Führen die dem Teil, das geprüft wird, Helium zu. Der Lecksucher verfolgt automatisch das Heliumsignal innerhalb des ausgewählten Bereichs. Sollte es den vorgegebenen Rückweisungswert übersteigen, zeigt das Leckratensignal den Höchststand an und die LED REJECT leuchtet auf.
7. Drücken Sie die Taste **VENT** und halten Sie sie ca. 1 Sekunde lang nieder, bis die Einheit auf den Modus VENT umschaltet.
  - Die LED TEST erlischt.
  - Die LED VENT leuchtet auf.

#### HINWEIS



*Wird die Taste **VENT** nicht eine Sekunde lang gedrückt, geht der Lecksucher auf **HOLD** über.*

8. Trennen Sie das Teil, das geprüft wird, vom Prüfport.

Die Leckprüfung ist nun abgeschlossen.

### 3.15 Bereitschaft

Wenn nicht mit einem kontinuierlichen Gebrauch der 947/948/960 zu rechnen ist, kann der Modus **STANDBY**, in dem die Einheit teilweise abgeschaltet wird, benutzt werden, um Energie zu sparen. 947/948/960 werden wie folgt auf den Modus **STANDBY** eingestellt:

1. Drücken Sie die Taste **VENT** und halten Sie sie nieder, bis die LED **VENT** aufleuchtet.
2. Stellen Sie den Schalter der Grobvakuumpumpe auf **OFF**.
3. Stellen Sie den Trennschalter der Grobvakuumpumpe auf **ON**, um den Lecksucher wieder auf den Modus **READY FOR OPERATION** zurückzustellen.

#### HINWEIS



*Wenn die Einheit nach einem Standby wieder betriebsbereit gemacht wird, brauchen die Warmlaufzeiten nicht eingehalten zu werden.*

### 3.16 Abschalten

Wenn der Standort der Maschine geändert oder sie vorübergehend nicht benutzt wird, kann sie wie folgt abgeschaltet werden:

1. Setzen Sie den Prüfportstecker sicher in die Prüfportbuchse ein.
2. Stellen Sie den Schalter für die Grobvakuumpumpe auf **OFF**.
3. Stellen Sie den Lecksucher-Schalter auf **OFF**.
4. Stellen Sie den Netz-/Trennschalter an der Rückseite des Schanks auf **OFF**.
5. Nur für die 948/960: entleeren Sie die Kühlfalle.

Für das Reinigungsverfahren siehe Abschnitt 4.2.4, "Flüssigstickstoff-Kühlfalle (nur Modelle 948/960)" auf Seite 4-11.

### 3.17 Parametereinstellung mit der Hängebedienungstafel

Die Hängebedienungstafel wird im Aufsatz aufbewahrt und ist zwecks Parameteränderungen, Überwachung und Diagnostik an den Modellen 947/948/960 an J1 im Aufsatz angeschlossen. Um eine dieser Funktionen bedienen zu können, muss die Hängebedienungstafel an die 947/948/960 angeschlossen sein. Für Informationen über die Aufsatzanschlüsse siehe Anhang G, "Leak Detection Theory".

Die Hängebedienungstafel dient zur Überwachung und Einstellung folgender Werte:

- Rückweisungs-Sollwert
- Crossover-Druckwerte
- Parameter der automatischen Sequenz
- Parameter der Ionenquelle
- Parameter der Systemeinstellung (wie der Wert des kalibrierten Lecks)

Beim Antrieb der Hängebedienungstafel über die 947/948/960 erscheint auf der Anzeige das Modell, an welches der Lecksucher angeschlossen ist. Auf dem Tastenfeld befinden sich Funktionstasten und numerische Tasten. Siehe Abbildung 3-10.



Abbildung 3-10 Tastenfeld der Hängebedienungstafel

Verschiedene Parameters, die sich auf den Betrieb und die Leistung der re947/948/960 Plattform beziehen, sind auf dem EPROM gespeichert. Diese Parameter werden über die Wartungs- oder rückseitigen seriellen Ports eingesehen oder geändert. Einige Parameter werden beim Aufstellen und Prüfen des Systems eingestellt. Andere Parameter müssen geändert werden, wenn ein Messgerät ausgewechselt oder wenn die Ionenquelle oder der Vorverstärker geändert wird. Einige Parameter ändern sich während der Inbetriebnahme, automatischen Kalibrierung oder Nullstellung automatisch. Für Einzelheiten siehe Anhang G, "Leak Detection Theory".

### 3.18 Optionale diskrete E/A

Sollen die optionalen diskreten E/A-Verbindungen benutzt werden, nehmen Sie die Anschlüsse an J120 und J121 an der rückseitigen Schalttafel vor. Für detaillierte Informationen siehe Anhang D, "Inputs and Outputs".

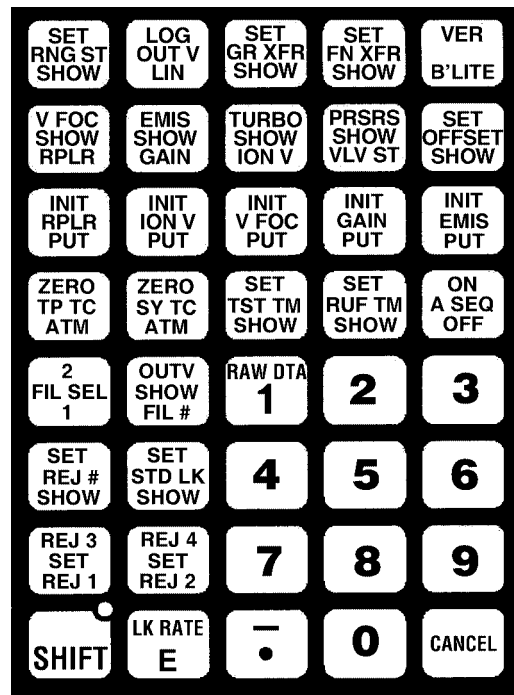
Bei einem Betrieb der 947/948/960 über die optionalen diskreten E/A ist es erforderlich, PARALLEL ENABLE (J120 Pin 6) zu aktivieren. So kann der Lecksucher Befehle von den anderen diskreten E/A-Eingängen empfangen. Eine Aktivierung von PARALLEL ENABLE verhindert gleichzeitig eine Änderung der Betriebsparameter über den seriellen Port, die Hängebedienungstafel oder die Fronttafel. Änderungsforderungen über den seriellen Port werden mit **cant** beantwortet.

*This page intentionally left blank.*



## Section 4. Maintenance

Like other sensitive test equipment, a mass spectrometer leak detector requires periodic maintenance to ensure continued reliable operation. After prolonged use, the leak detector accumulates contaminants from even the cleanest of products tested. These contaminants eventually impair operation. A thorough disassembly and cleaning of the entire vacuum system, which includes the cal leak valve block and spectrometer tube, restores normal operation. For heavy production use, more frequent overhauls are needed. In most cases, this work is done by user maintenance personnel, but it may also be done by Varian Vacuum Technologies under the terms of a service contract.

This maintenance section does not cover overhaul of the entire vacuum system. It does cover daily maintenance and as-required maintenance.

### ***Important Reminders***

Heed the following notes, cautions, and warnings when performing maintenance.

**WARNING**



*Disconnect power from the 947/948/960 before performing any maintenance procedure that requires physically disconnecting any part of the system.*

**WARNING**



*The mechanical components of leak detectors are typically cleaned with alcohol or other solvents. When heated, sprayed, or exposed to high-temperature equipment, these solvents become flammable and explosive, causing serious injury or death. Do not use near a high-temperature source. Ventilate the work area with a blower and use solvents only in large, well-ventilated rooms.*

*Alcohol and other solvents are irritants, narcotics, depressants, and/or carcinogens. Their inhalation and/or ingestion may produce serious effects. Prolonged or continued contact with the skin results in absorption through the skin and moderate toxicity. Always ensure that cleaning operations are carried out in large, well-ventilated rooms. Wear eyeshades, gloves, and protective clothing.*

**WARNING**



*The preamplifier is a static sensitive device. Wear a grounding device while the preamplifier is being handled.*

Cleanliness is vital when servicing the leak detector or any vacuum equipment. The following are especially important in the servicing of leak detectors:

### CAUTION



*Do not use silicone oil or silicone grease.*

*Use powder-free butyl or polycarbonate gloves to prevent skin oils from getting on vacuum surfaces.*

*Do not clean any aluminum parts with Alconox. Alconox is not compatible with aluminum and will cause damage.*

### NOTE



*Normally, the use of vacuum grease is unnecessary. If it must be used, use it sparingly and avoid silicone types. Apiezon L grease is recommended (Varian P/N 695400004).*

When removing, checking, or replacing O-rings:

### CAUTION



*Remove O-rings carefully with your fingers. Do not use metal tools which could scratch the sealing surfaces.*

*Do not use alcohol, methanol, or other solvents on O-rings. To do so causes deterioration and reduces their ability to hold a vacuum.*

*Wipe all O-rings clean with a lint-free cloth before installation to ensure that no foreign matter is present to impair the seal. Do not use grease or other substances on O-rings that come in contact with the spectrometer tube.*

## Models 947, 948 and 960 Leak Detectors Operations and Service Manual

Due to the effective cleaning nature of VacuSolv solvent and its residue-free properties, Varian Vacuum Technologies' Component and Spectrometer Tube Cleaning Kit (Varian P/N 670029096), used in accordance with the kit instructions, is recommended for cleaning the spectrometer tube components. The kit can also be used for fine cleaning of other parts in the leak detector vacuum system such as valves and fittings. No rinsing steps or high-temperature drying is required following a cleaning with VacuSolv. Although appropriate precautions are advised, VacuSolv is compatible with most materials and does not contain toxic chemicals or CFCs (chlorofluorocarbons).

The scheduled maintenance functions in this section are grouped by recommended frequency, as shown in Table 4-1, based on assumed everyday use. The 947/948/960 operates at its peak when maintenance (preventive) procedures are performed at their scheduled intervals. Read the pump manuals that came with your 947/948/960 leak detector for more complete maintenance information specific to the pumps. See "Spare Parts" on page 4-37 for more information.

The 947/948/960 must be calibrated to verify sensitivity at least once a day. However, other functions may be carried out more or less often, depending on the frequency of use.

**Table 4-1 Scheduled Maintenance**

Description	Daily	12 Months	Refer to
Calibration check	●		"Calibration Check" on page 4-5
Re-calibrate the internal calibrated leak		●	"Re-calibrate the Internal Calibrated Leak" on page 4-7
Spectrometer tube overhaul		●	"Spectrometer Tube Overhaul" on page 4-12
Filter replacement		●	"Air Filter" on page 4-22

## Models 947, 948 and 960 Leak Detectors Operations and Service Manual

On-demand maintenance functions are listed in Table 4-2.

**Table 4-2 As-Required Maintenance**

Most Common Symptom	Refer to
Trap almost empty, nearly 14 hours without a refill.	"Liquid Nitrogen Cold Trap (Models 948/960 only)" on page 4-10
Preamplifier failure.	"Spectrometer Tube Exchange" on page 4-23
Loss of sensitivity, increase in background, high ion voltage (> 300 VDC), required to tune the leak detector.	"Spectrometer Tube Overhaul" on page 4-12
Filament failure (as soon as convenient after second filament is in use).	"Replacing the Ion Source" on page B-6
Pump running rough, vacuum not attainable.	"Rough Pump and Forepump Oil Level Check (Oil-sealed Mechanical Pumps)" on page 4-34
<p>TC1 gauge needs replacement as indicated by the fact that:</p> <ul style="list-style-type: none"> <li><input type="checkbox"/> Test port pressure does not come down (atmosphere indication) when start button is pushed (test mode) assuming no leaks.</li> <li><input type="checkbox"/> Test port pressure comes down slightly (1/4 to 1/2 scale) when test port plug is installed, once again assuming no leaks can be heard or seen (gross leak).</li> </ul> <p>TC2 gauge needs replacement as indicated by the fact that:</p> <ul style="list-style-type: none"> <li><input type="checkbox"/> Spectrometer tube pressure shows high pressure (full scale indication). System will not activate the ion source filament due to a false high pressure indication, a failed turbo pump, or a leak in the spectrometer tube.</li> <li><input type="checkbox"/> Spectrometer tube pressure comes down slightly (1/4 to 1/2 scale) after the leak detector has been warmed up for 30 minutes.</li> </ul>	"TC1 and TC2 Gauge Replacement and Calibration" on page 4-26
<p>Unsatisfactory condition on visual inspection.</p> <p>The frequency of port cleaning depends on the application.</p>	"Cleaning the Test Port" on page 4-35

## 4.1 Daily Maintenance

### 4.1.1 Calibration Check

To perform a calibration check:

1. Press the STD LEAK button.
2. Compare the value displayed on the 947/948/960 to the value of the known calibrated leak listed on the label on the top of the turret.

Refer to Figure 1-1 on page 1-2 for the location of the label.

3. If the values do not match, press the **AUTO CAL** button and then repeat step 1.

Detailed instructions for sensitivity and calibration checks are included in “Calibration and Sensitivity Checks” on page 3-11. If specifications cannot be met, Manual Tuning is required. Manual Tuning is restricted to trained, qualified customer technicians. Contact Varian Vacuum Technologies Customer Service at 1-800-8VARIAN if manual tuning is necessary.

#### 4.1.1.1 Leak Checking

The accuracy, reliability, and stability of any mass spectrometer leak detector depends on the leak-free integrity of its own vacuum system. Inherent helium background and its effect on sensitivity demands elimination of all detectable leaks. If performance degrades during operation or after some part of the vacuum system is opened for service, a methodical leak check eliminates the possibility of a leak as the cause.



*To ensure reliable testing, after servicing any part of the vacuum system, the 947/948/960 must be leak checked again.*

### 4.1.1.2 General Suggestions for Leak Checking

The following suggestions apply whether leak checking components, systems, or the leak detector itself:

1. When spraying suspected leak locations:
  - Always apply helium sparingly.
  - Since helium rises, start at the highest points first.
  - Apply helium downstream from the source of a draft first, or deflect the draft until leak checks are completed.
2. If vent grooves exist at flanges or other assembled seals, apply helium to these points (rather than spraying a general area) to:
  - Obtain the most positive response.
  - Minimize the use of helium.
  - Save time in checking.
3. Locate and repair large leaks before attempting to locate extremely small leaks.
4. Limit the search to a general area of the test piece by isolation methods to shorten the time required to locate both large and small leaks. Isolation methods include:
  - Bagging
  - Masking
  - Shielding with tape, plastic film or duct seal (if applied properly)
5. Use only enough helium to reach the leaks. Do not flood the area.

## 4.2 Yearly Maintenance

### 4.2.1 Replacing the Calibrated Leak

#### 4.2.2 Re-calibrate the Internal Calibrated Leak

Helium calibrated leaks typically degrade at 3 percent per year. The calibrated leak supplied with your 947/948/960 must be checked at least once a year to ensure it is at the value stated on its label. Failure to check the leak could result in unreliable testing. You can arrange for testing and re-calibration at a lab of your choice.

Varian Vacuum Technologies provides NIST-traceable calibrated leak testing and verification services. Contact Customer Service at 1 (800) 8VARIAN to arrange for re-calibration.

#### 4.2.2.1 Removing the Internal Calibrated Leak

The calibrated leak is located in the main cabinet area near the top of the leak detector as shown in Figure 4-1.



Figure 4-1 Location of the Calibrated Leak

To remove the internal calibrated leak:

1. Disconnect the mains power supply and make sure all pumps are off.

**WARNING**



*Disconnect power from the 947/948/960 before performing any maintenance procedure that requires physically disconnecting any part of the system.*

**CAUTION**



**Models 948/960 only:** *Remove, empty, and clean the cold trap whenever power is removed. Refer to "Liquid Nitrogen Cold Trap (Models 948/960 only)" on page 4-10.*

2. Remove the top panel of the 947/948/960.
3. Vent the turbo by turning the knurled nut on the turbo pump  $\frac{1}{4}$  turn clockwise and then close it.
4. Loosen the thumbscrew on the top of the cross bar by turning it clockwise, but do not remove it completely.
5. Grasp the calibrated leak and pull it straight back to remove it.
6. If the O-ring and centering ring do not come out with the calibrated leak, reach into the cavity and remove them.

**CAUTION**



*Remove O-rings carefully with your fingers. Do not use metal tools for this task. This prevents scratching of any sealing surfaces.*



### 4.2.2.2 Replacing the Internal Calibrated Leak

To replace the calibrated leak:

1. Wipe the O-ring with a lint-free cloth to ensure that no foreign matter is present.

#### CAUTION



*Varian recommends replacing all used O-rings.*

*Do not use grease or other substance on O-rings that come in contact with the spectrometer tube.*

*If applicable, apply a small amount of Apiezon<sup>®</sup> L grease and wipe the O-rings "shiny" dry.*

*Do not use alcohol, methanol or other solvents on O-rings. To do so causes deterioration and reduces their ability to hold a vacuum.*

2. Place the O-ring onto the centering ring.
3. Place the centering ring onto the calibrated leak.
4. Insert the calibrated leak into the cavity, orienting the leak so the value can be read easily.

#### NOTE



*To ensure reliable testing, after servicing any part of the vacuum system, the 947/948/960 must be leak checked again. Refer to "Leak Checking" on page 4-5 for guidelines.*

5. Replace the top panel and connect mains power.
6. Turn the leak detector on and wait for the pumps to come up to speed.
7. **Models 948/960 only:** Once the system has pumped down, clean and fill the Liquid Nitrogen Cold Trap using the procedure described in "Liquid Nitrogen Cold Trap (Models 948/960 only)" on page 4-10.

Follow all warnings and cautions in the procedure.

8. Calibrate the 947/948/960 using the procedure described in "Re-calibrate the Internal Calibrated Leak" on page 4-7.
9. Leak check the assembly before using the 947/948/960 for testing.

### 4.2.3 Liquid Nitrogen Cold Trap (Models 948/960 only)

The trap should be refilled with liquid nitrogen (LN<sub>2</sub>) as needed. A typical time frame for refilling is every 14 hours, depending on usage. During normal usage of the 948/960 Platform leak detector, water vapor and other contaminants build up on the surface of the nitrogen trap.

To clean the cold trap:

1. Shut down the machine completely.
2. After approximately 30 minutes, slowly open the vent valve on the top of the Liquid Nitrogen trap to vent the trap.
3. Don protective gear, such as *loose fitting gloves and eye or face shield*, and remove the cold trap.

#### **WARNING**

*Liquid nitrogen causes burns upon contact.*



4. Clean the trap with soap and water only after it has warmed up to room temperature.
5. Rinse it well and dry it completely inside and out using a lint free cloth.

#### **CAUTION**

*The outside of the cold trap must be completely dry or ice will form and can be dragged into sensitive equipment when the leak detector is turned on.*



6. Once the trap is clean, replace it in the 948/960, and close the vent valve on the top of the Liquid Nitrogen trap.
7. To re-establish operation, carefully refill the trap with LN<sub>2</sub>, using the safety procedure above, and follow normal startup procedures for Models 948/960.

### 4.2.4 Flüssigstickstoff-Kühlfalle (nur Modelle 948/960)

Die Falle muss je nach Bedarf mit Flüssigstickstoff (LN<sub>2</sub>) aufgefüllt werden. Je nach Gebrauch ist ein Nachfüllen alle 14 Stunden erforderlich. Während des Gebrauchs des 948/960 Plattform-Lecksuchers sammeln sich Wasserdampf und andere Kontaminationsstoffe auf der Oberfläche der Stickstofffalle an.

Gehen Sie bei der Reinigung der Kühlfalle wie folgt vor:

1. Schalten Sie die Maschine ganz aus.
2. Öffnen Sie nach ca. 30 Minuten langsam das Ablassventil auf der Oberseite der Flüssigstickstofffalle, um die Falle abzulassen.
3. Legen Sie Schutzkleidung an, wie z.B. *locker* sitzende *Handschuhe* und *Augen-* bzw. *Gesichtsschutz*, und entfernen Sie die Kühlfalle.

#### **WARNUNG**



*Flüssigstickstoff verursacht Verbrennungen durch Berührung..*

4. Reinigen Sie die Falle erst dann mit Seife und Wasser, wenn sie Raumtemperatur erreicht hat.
5. Spülen Sie die Falle gut aus und reiben Sie die Innen- und Außenflächen mit einem fuselfreien Tuch vollkommen trocken.

#### **VORSICHT**



*Die Außenflächen der Kühlfalle müssen vollkommen trocken sein, da sich sonst Eis bildet, das dann beim Einschalten des Lecksuchers in empfindliche Geräte gesaugt werden kann*

6. Setzen Sie die Kühlfalle nach ihrer Reinigung wieder in die 948/960 ein und schließen Sie das Ablassventil an der Oberseite der Flüssigstickstofffalle.
7. Füllen Sie die Falle vor der erneuten Inbetriebnahme vorsichtig mit LN<sub>2</sub> unter Befolgung des oben beschriebenen Sicherheitsverfahrens, und führen Sie dann die normalen Verfahren zur Inbetriebnahme für Modelle 948/960 aus.

## 4.2.5 Spectrometer Tube Overhaul

Spectrometer tube overhaul consists of removing, cleaning, and re-installing the 947/948/960 Spectrometer Tube Assembly.

### WARNING



*Liquid nitrogen causes burns upon contact. Use appropriate protective devices, including heavy loose gloves and eye or face shields.*

### NOTE



**Models 948/960 only:** Before servicing the Spectrometer Tube, refer to Section 4.2.3, "Liquid Nitrogen Cold Trap (Models 948/960 only)" on page 4-10 for the procedure to empty the Cold Trap, steps 1, 2, and 3. Do not refill the Cold Trap until service is complete.

There are three basic sub-assemblies in the spectrometer tube:

- Ion Source
- Preamplifier
- Magnetic Poles

Table 4-3 lists the tools and parts required during spectrometer tube overhaul.

**Table 4-3 Tools and Parts Required for Spectrometer Tube Overhaul**

Tools	
Slotted screwdriver	Phillips screwdriver
5-64 Hex wrench	Screw capturing screwdriver
Feeler gauge	Socket wrench
Allen wrench	
Part	Part Number
Metal Seal	L5873001
Ion Source	82850302
TC Gauge (TC1)	F0472301
TC Gauge (TC2)	F0472301
Spectrometer Tube Cleaning Kit	670029096
O-rings	

### 4.2.5.1 Removal of the Spectrometer Tube and Preamplifier

Refer to Figure 4-2 for the removal of the 947/948/960 spectrometer tube.

#### WARNING



*Liquid nitrogen causes burns upon contact. Use appropriate protective devices, including heavy loose gloves and eye or face shields.*

#### NOTE



**Models 948/960 only:** Before servicing the Spectrometer Tube, refer to "Liquid Nitrogen Cold Trap (Models 948/960 only)" on page 4-10 for the procedure to empty the Cold Trap, steps 1, 2, and 3. Do not refill the Cold Trap until service is complete.

To remove the spectrometer tube:

1. Insert the plug in the test port and tighten the test port securely.
2. Shut down the leak detector via the Main switch/circuit breaker on the rear of the lower cabinet.
3. Disconnect power from the leak detector.
4. Remove the lower front panel of the leak detector to allow access to the vacuum system.
5. Momentarily open the turbo vent screw ③, to bring the vacuum system to atmosphere.

#### CAUTION



*Use powder-free butyl or polycarbonate gloves to prevent skin oils from getting on vacuum surfaces.*

6. Disconnect all four electrical connections to the spectrometer tube ①.



*To remove the locking connector shown in Figure 4-2, both metal tabs at the left of the connector must be pushed to unlock the connector, then pull the connector to the right to remove it.*

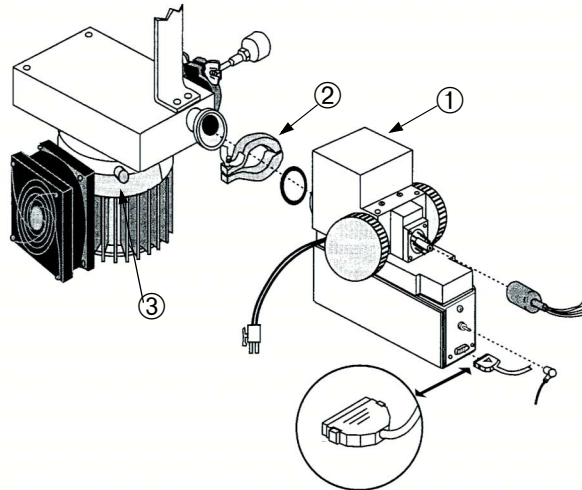

**Figure 4-2 947/948/960 Spectrometer Tube Removal**

7. Hold the spectrometer tube and loosen the wing nut holding the KF clamp ②.
8. Remove the clamp that holds the spectrometer tube to the Service Block Assembly (SBA).
9. Rock the tube to slowly break any residual vacuum.
10. Place the spectrometer tube and O-ring on a clean, non-magnetic bench for further maintenance.

### 4.2.5.2 Disassembly of the Spectrometer Tube and Preamplifier

To disassemble the spectrometer tube:

1. Remove the four screws on the spectrometer tube (Figure 4-3), noting the placement of the grounding strap ①.

The grounding strap must go back on the same screw during reassembly.

#### CAUTION



*The preamplifier is a static sensitive device. Wear a grounding device while the preamplifier is being handled.*

2. Loosen the four 5-64 Allen set screws on the edges of the magnet assembly that hold the fixed and adjustable pole pieces in place.
3. Remove the pole pieces ⑫ and the black plastic tuning knobs ⑪.
4. Separate the magnet assembly ② from the spectrometer tube body ③.
5. Remove the four Phillips head screws that hold the flange cap ④ onto the spectrometer tube body.
6. Firmly but gently separate the flange cap from the ion source ⑤.
7. Remove both the O-ring on the ion source, and the ion source.
8. Remove the ground slit plate ⑥ from the ion source cavity with a long, thin screw-holding screwdriver.
9. Remove the four slotted screws on each side of the spectrometer tube body and slip out both deflection pole pieces ⑦. The deflection pole pieces are interchangeable.
10. Remove the O-ring.
11. Remove the heater cartridge ⑧ by pulling it free of its cavity.
12. Remove the five Phillips head screws that hold the preamplifier cover ⑨ on.
13. Remove the preamplifier ⑩, connector bracket, and collector housing assembly in the following sequence:
  - Remove the Phillips head screw at the base of the connector bracket.
  - Remove the four socket head cap screws, sized 8-32, that mount the collector housing to the spectrometer tube body, using a 9-64 short Allen wrench inserted between the printed wiring board and the screw head.
  - Remove the metal seal on the collector housing assembly.

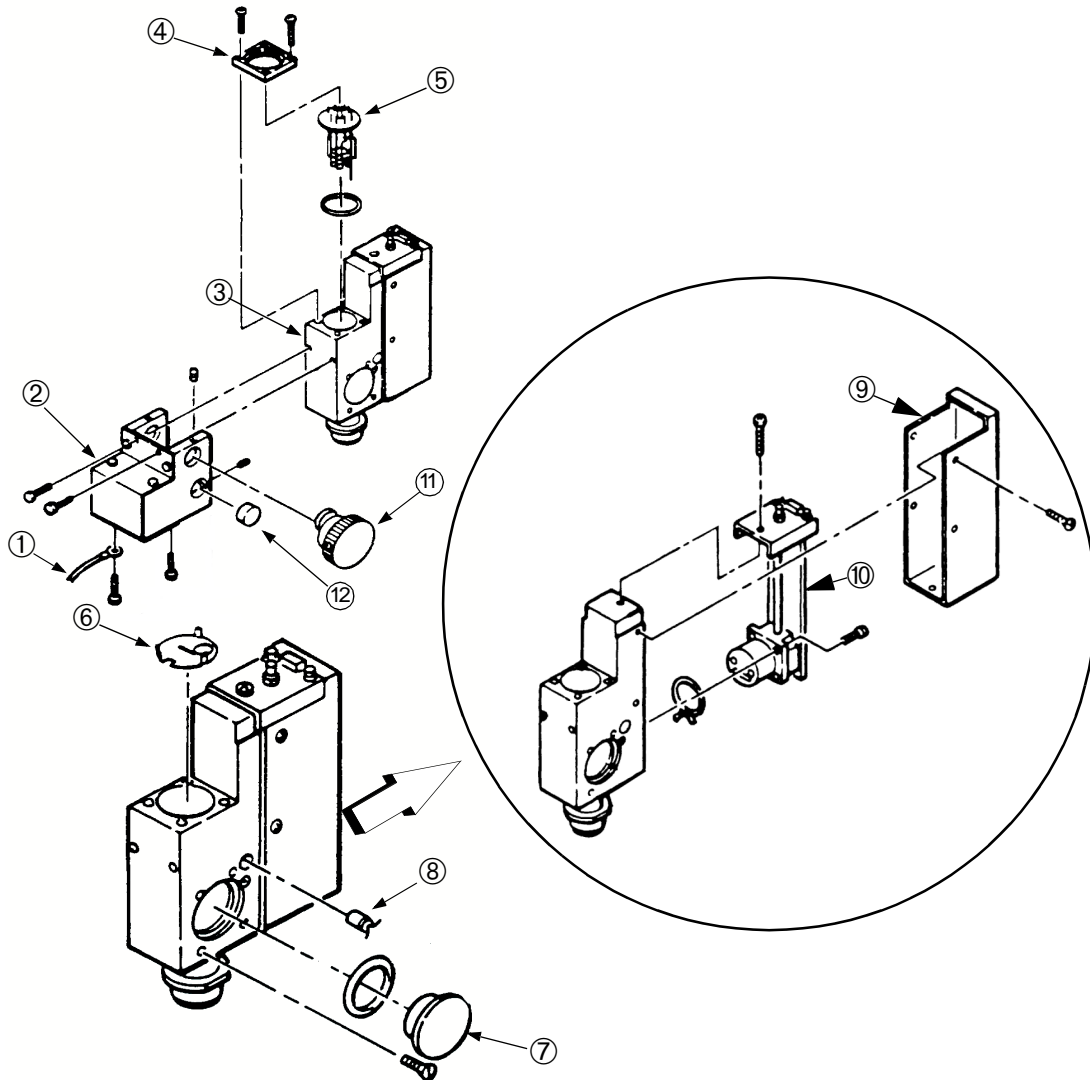

Figure 4-3 Spectrometer Tube Disassembly

**WARNING**



*Store the Ion Source in a cool, dry area in a tightly sealed container. Wash hands thoroughly after handling the Ion Source and especially before smoking or eating.*

**CAUTION**



*Do not use methanol or other solvents on O-rings. To do so causes deterioration and reduces their ability to hold a vacuum.*

*Do not clean any aluminum parts with Alconox. Alconox is not compatible with aluminum and will cause damage.*



*Use new O-rings wiped clean with a lint-free cloth. Do not apply vacuum grease to O-rings that come in contact with the spectrometer tube.*

### 4.2.5.3 Spectrometer Tube Cleaning

To clean the spectrometer tube:

1. Use the Scotch-Brite™ flexible abrasive pads from the spectrometer cleaning kit to remove heavy deposits from the ground slit plate, and spectrometer tube body.
2. Wipe all parts with VacuSolv wipes.
3. Allow parts to air dry thoroughly.

### 4.2.5.4 Reassembly of the Spectrometer Tube and Preamplifier

To reassemble the spectrometer tube:

Refer to Figure 4-4 for step 1 through step 5, to Figure 4-5 for step 6 through step 8, and Figure 4-6 on page 4-20 for step 9 through step 13.

1. Place a new metal seal ① on the collector housing assembly ② with the ends of the seal crossed under one of the screw holes (Figure 4-4, View A).
2. Mount the collector housing assembly to the spectrometer tube body ③ with the four socket head cap screws, sized 8-32.
3. Tighten all four screws in an opposing sequence until a 0.007" clearance is attained between the collector housing assembly and the spectrometer tube body.

Use a feeler gauge to measure the clearance and another leak detector (if available) to leak check to  $1 \times 10^{-9}$  atm cc/sec.

4. The preamplifier ④, connector bracket, and collector housing assembly that came off as one unit can now be reattached to the spectrometer tube body by replacing the screw at the base of the connector bracket.
5. Replace the preamplifier cover ⑤ and the five Phillips head screws that hold it in place.

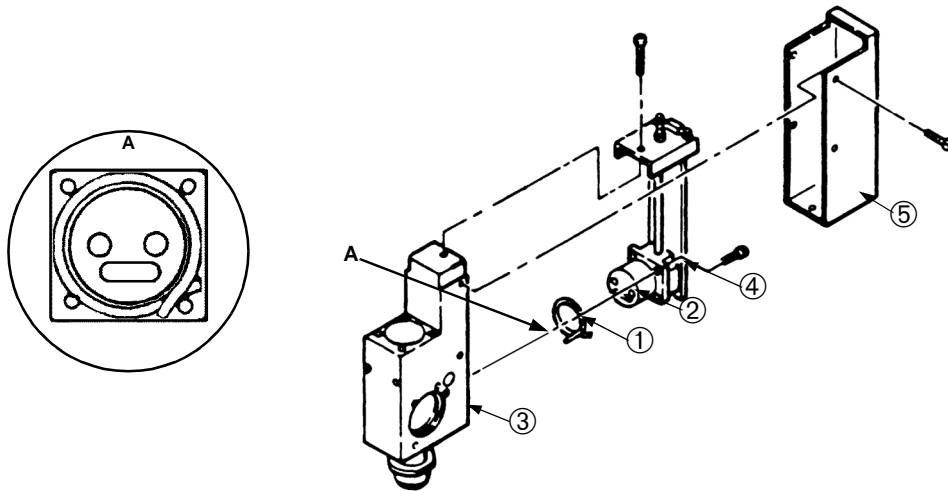

**Figure 4-4 Spectrometer Tube Reassembly**

- Put the heater cartridge ① back in its cavity (Figure 4-5).

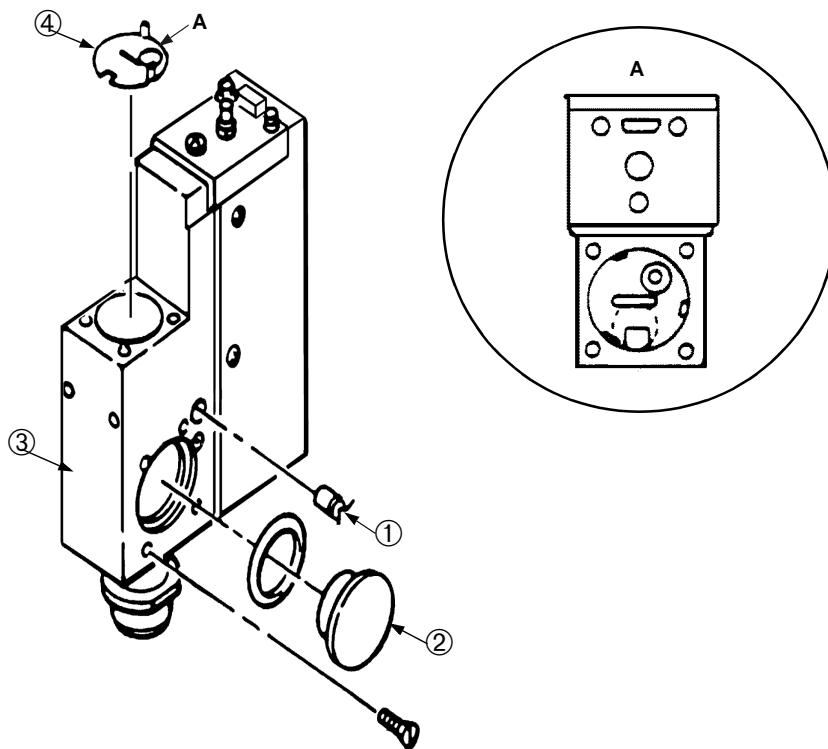

**Figure 4-5 Spectrometer Tube Reassembly (Ground Slit Plate)**

- With the new O-rings on each of the two deflection pole pieces ②, insert the pole pieces into the spectrometer tube body ③, tighten the four slotted screws on each side of the spectrometer tube, and note the positions of both the roll pin in the body and the notch in the pole piece flange used for alignment.

8. When installing the ground slit plate ④, be sure that the snap prongs are facing up, then align the slit at 90° with the side wall of the spectrometer tube, and concentrically align the circular hole in the plate with the smaller guide hole in the bottom of the ion source cavity (Figure 4-5, View A).
9. Wipe the new O-ring ① and mating surfaces with a clean, lint-free cloth and place the new ion source ② in its cavity (Figure 4-6 on page 4-20) as follows:
  - ❑ Place the locating pin ③ approximately in the center of the guide hole.
  - ❑ Ensure that pins 1 and 8 ④ are parallel to the side wall of the spectrometer tube as shown in Figure 4-6 on page 4-20, View A.
  - ❑ Tighten the flange cap ⑤ evenly and firmly with the four Phillips head screws.

### CAUTION



*A short could result at power up if the alignment pin touches the sides of the alignment hole.*

10. Fit the magnet assembly ⑥ back onto the spectrometer tube body.
11. With the grounding strap ⑦ attached to the same screw from which it was removed, replace and tighten the four screws that fit into the magnet assembly.
12. Insert the pole pieces ⑧ and the black plastic knobs ⑨ making sure that the pole pieces are snug against the body, and tighten the 5-64 Allen set screws.
13. Leak check the assembly before reinstalling the spectrometer tube into the leak detector.



## 4.2.5.5 Reinstallation of the Spectrometer Tube

### WARNING



Liquid nitrogen causes burns upon contact. Use appropriate protective devices, including heavy loose gloves and eye or face shields.

### NOTE



**Models 948/960 only:** Before servicing the Spectrometer Tube, refer to "Liquid Nitrogen Cold Trap (Models 948/960 only)" on page 4-10 for the procedure to empty the Cold Trap, steps 1, 2, and 3. Do not refill the Cold Trap until service is complete.

To reinstall the spectrometer tube:

1. Place the cleaned, new, ungreased centering ring and O-ring on the vacuum flange of the spectrometer tube.
2. Hold the spectrometer tube ① in place and attach the KF clamp ② and tighten as required.
3. Reconnect the four electrical connections that were disconnected from the spectrometer tube.

Pay special attention when attaching the locking connector shown in Figure 4-7.

- a. Press the tabs on the sides of the connector.
- b. Push the connector onto its mating part.
- c. Slide the tabs to lock the connector in place.

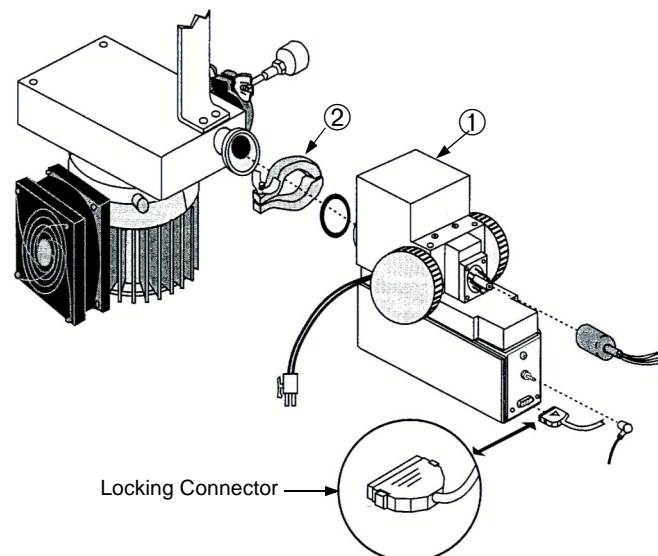
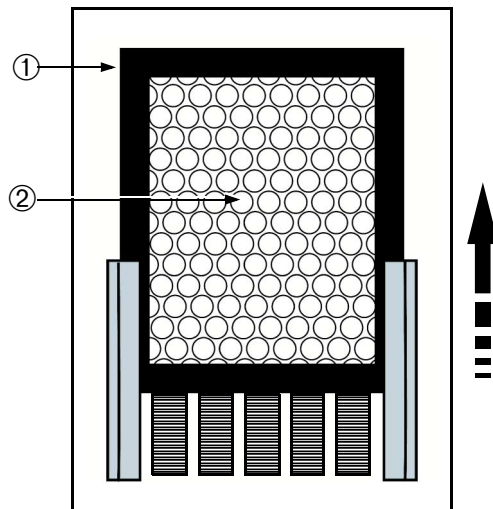

**Figure 4-7 947/948/960 Spectrometer Tube Installation**

4. **Models 948/960 only:** Fill the Liquid Nitrogen Cold Trap using the procedure described in "Liquid Nitrogen Cold Trap (Models 948/960 only)" on page 4-10, steps 5 and 6.
5. Reconnect power and start the leak detector and refer to the "Calibration and Sensitivity Checks" on page 3-11.
6. Leak check before using for testing.

### 4.2.6 Air Filter

Check the air filter weekly for dust and dirt. Check more frequently if operating in a dirty area. The removal of the front lower panel exposes the air filter, as shown in Figure 4-8. When buildup of dirt, dust, or other contaminants is apparent, replace the filter with a commercial filter (size 16" x 20" x 1").



**Figure 4-8 Air Filter Replacement**

- |                     |  |
|---------------------|--|
| ① Front lower panel | Removable front panel of the 947/948/960 |
| ② Air filter        | Commercial filter (16" x 20" x 1")       |

The air filter should be replaced at least every 12 months to ensure proper airflow through the 947/948/960.

To replace the air filter:

1. Remove the front panel of the 947/948/960.
2. On the inside of the front panel, grasp the filter at the top.
3. Pull the filter up out of the holder.
4. Remove the filter element and discard it.
5. Place a new filter element into the housing.

### 4.2.7 Spectrometer Tube Exchange

The spectrometer tube replaceable parts consist chiefly of the ion source, the preamplifier, the magnetic poles, and the spectrometer tube as a complete assembly.



*Because of the complexity and sensitivity of the preamplifier, Varian recommends replacing the entire spectrometer tube if the preamplifier must be replaced.*

*Rebuilt spectrometer tubes are available from Varian Vacuum Technologies on an exchange basis. Contact Varian Vacuum Technologies Customer Service at 1-800-8VARIAN for details.*

Replacement of the ion source or preamplifier requires removal of the spectrometer tube. Complete overhaul of the spectrometer tube includes complete disassembly of the spectrometer tube including replacing the ion source and preamplifier. Both procedures require that calibration, tuning and leak checking be performed prior to using the 947/948/960 for testing.

**CAUTION**



*Use powder-free butyl or polycarbonate gloves to prevent skin oils from getting on vacuum surfaces.*

*The preamplifier is a static sensitive device. Wear a grounding device while the preamplifier is being handled.*

**WARNING**



*Store the Ion Source in a cool, dry area in a tightly sealed container. When handling the Ion Source, wear powder-free butyl or polycarbonate gloves. If you handle the Ion Source with bare hands, wash them thoroughly and especially before smoking or eating.*

#### 4.2.7.1 Removing and Replacing both the Spectrometer Tube Assembly and Preamplifier

Refer to “Disassembly of the Spectrometer Tube and Preamplifier” on page 4-15.

#### 4.2.7.2 Reinstalling the Spectrometer Tube

To perform this procedure:

1. Using a VacuSolv wipe, clean the SVBA flange and allow it to air dry completely.
2. Place the clean, new, ungreased centering ring and O-ring on the vacuum flange of the spectrometer tube.

### CAUTION



*Do not use grease or other substances on O-rings that come in contact with the spectrometer tube.*

*Wipe all O-rings clean with a lint-free cloth before installation to ensure that no foreign matter is present to impair the seal.*

3. Hold the spectrometer tube against the centering ring, attach the NW25 clamp, and tighten the clamp fully.
4. Reconnect the ion source connector, the preamplifier locking D-sub connector, the Molex connector to the heater, and the suppressor.
  - a. When attaching the locking connector (Figure 4-9), press the tabs on the sides of the connector
  - b. Push the connector onto its mating part.
  - c. Slide the tabs to lock the connector in place.

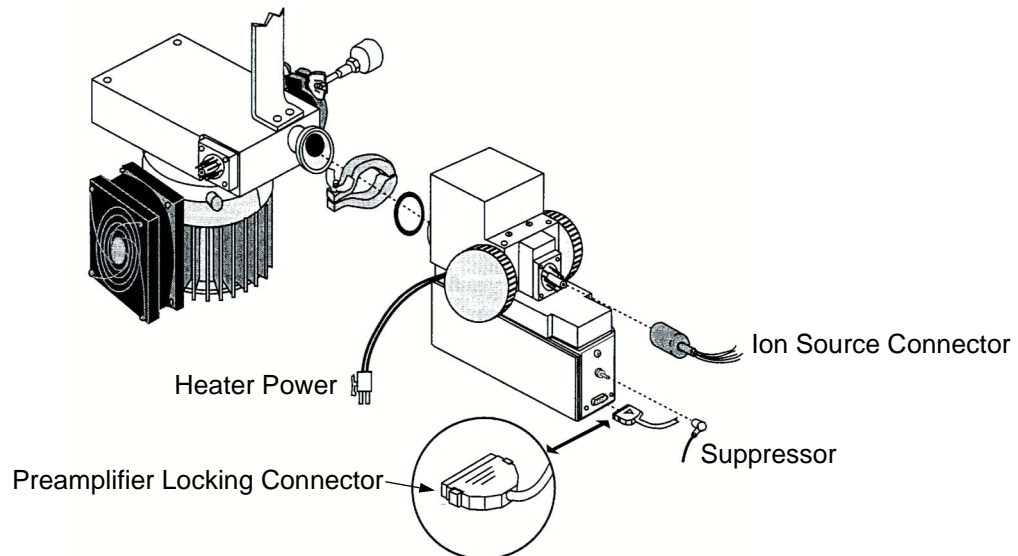

**Figure 4-9 947/948/960 Spectrometer Tube Installation**

### NOTE



*To ensure reliable testing, after servicing any part of the vacuum system, the 947/948/960 must be leak checked again. Refer to "Leak Checking" on page 4-5 for guidelines.*

5. Replace the front panel and connect mains power.
6. Turn the leak detector on and wait for the system to be ready.

Allow the pumps to warm up if the detector has been off for some time.



7. **Models 948/960 only:** Once the system has pumped down, clean and fill the Liquid Nitrogen Cold Trap using the procedure described in “Liquid Nitrogen Cold Trap (Models 948/960 only)” on page 4-10.

Follow all warnings and cautions in the procedure.

8. Calibrate and tune the 947/948/960 using the procedure described in “Re-calibrate the Internal Calibrated Leak” on page 4-7.
9. Leak check the assembly before using the 947/948/960 for testing.

### 4.2.8 TC1 and TC2 Gauge Replacement and Calibration

#### 4.2.8.1 Replacement of the TC1 Gauge in the Main Valve Block Assembly

Figure 4-10 shows the valve block removed from the system.



*It is not necessary to remove the valve block to replace the TC1 thermocouple gauge.*

To replace the TC1 gauge in the Main Valve Block Assembly (MVBA):

1. Press the VENT button on the front panel to vent the leak detector.
2. Disconnect the mains power supply and make sure all pumps are off.
3. Grasp the plug and remove the plug and the thermocouple gauge ① from the valve block (Figure 4-10).
4. Disconnect the plug from the thermocouple gauge.
5. Remove the O-ring ③ and backing ring ② from the thermocouple gauge (Figure 4-10).

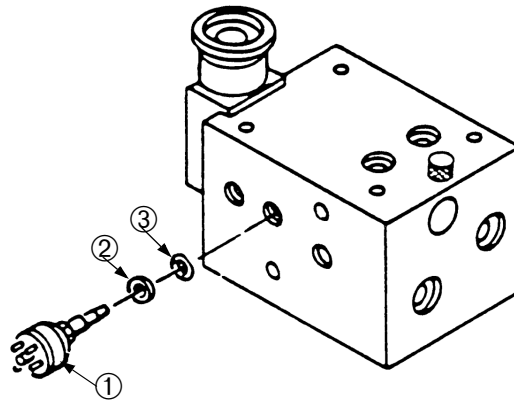

**Figure 4-10 TC1 Gauge in the MVBA**

6. Examine the O-ring for wear.

If necessary, use a new O-ring, otherwise clean the O-ring.



*Before re-using O-rings or installing new O-rings, wipe them down with a lint-free cloth before installation to ensure that no foreign matter is present to impair the seal. If applicable, apply a small amount of Apiezon L grease and wipe the O-rings "shiny" dry.*

7. Wipe the O-rings clean with a lint-free cloth before installing to ensure that no foreign matter is present to impair the seal.
8. Examine the backing ring.

If there are nicks or other signs of wear, replace it. If necessary, use a VacuSolv wipe to remove any dirt or foreign matter from the backing ring, otherwise wipe it with a lint-free cloth.
9. Place the backing ring ② and then the O-ring ③ onto the end of the new thermocouple gauge and move them down toward the gauge as far as they will go.
10. Place the plug connector onto the thermocouple gauge.

The center post is keyed so it only goes on one way.
11. Insert the thermocouple gauge into the valve block making sure it is firmly seated into the valve block.
12. Connect mains power.
13. Turn the leak detector on and wait for the system to be ready.

Allow the pumps to warm up if the detector has been off for some time.
14. Calibrate the thermocouple gauge using the procedure described in "Test Port Pressure Gauge (TC1) Calibration" on page 4-32.
15. Calibrate using the procedure described in "Calibration Check" on page 4-5.
16. Leak check the assembly before using the 947/948/960 for testing.



- Clean the centering ring and adapter with acetone, making sure all traces of pipe sealant are removed from the threads of the adapter.
- Examine the O-ring for wear.

If necessary, use a new O-ring, otherwise clean the O-ring by wiping it O-ring clean with a lint-free cloth before installation to ensure that no foreign matter is present to impair the seal.



*If applicable, apply a small amount of Apiezon L grease and wipe the O-rings "shiny" dry.*

- Place Loctite PST thread sealant onto the second and third threads of the new thermocouple gauge.
- Insert the thermocouple gauge into the adapter and hand tighten it fully.
- Place the O-ring onto the centering ring and onto the flange of the SBA.
- Place the adapter against the center ring.
- Replace the KF25 clamp and tighten the wing nut fully.
- Place the plug connector onto the thermocouple gauge.  
The center post is keyed so it only goes on one way.
- Models 948/960 only:** Refill the Cold Trap using the procedure described in "Liquid Nitrogen Cold Trap (Models 948/960 only)" on page 4-10.
- Connect mains power.
- Turn the leak detector on and wait for the system to be ready.  
Allow the pumps to warm up if the detector has been off for some time.
- Calibrate the thermocouple gauge using the procedure described in "System Pressure Gauge (TC2) Calibration" on page 4-30.
- Calibrate the leak using the procedure described in "Calibration Check" on page 4-5.
- Leak check the assembly before using the 947/948/960 for testing.

### 4.2.8.3 Thermocouple Gauge Calibration Procedures

Use the Service Pendant to perform a calibration on either the system pressure thermocouple (TC2) or the test port thermocouple gauge (TC1). Refer to Appendix A, “Service Pendant Keypad Functions” for information about using the Service Pendant.



*The calibration of the test port thermocouple (TC1) gauge is factory set and requires the use of a reference TC and a PC.*

### 4.2.8.4 System Pressure Gauge (TC2) Calibration

This procedure allows for calibration of the system pressure thermocouple gauge. Both the Vacuum and Atmospheric Calibrations procedures must be performed in the order written.

#### 4.2.8.4.1 Vacuum (Low Pressure) Calibration

To perform this procedure:

1. Verify that the leak detector is in the READY condition (the NOT READY LED is *not* illuminated) and that the test port plug is in place.
2. If the system is not already in VENT mode, press the **VENT** button. Verify that the VENT LED is illuminated.
3. Wait approximately five minutes for the vacuum system pressure to stabilize.
4. On the Service Pendant, press shift and the **SY TC ZERO** key.
  - The Pendant screen confirms that the calibration was successful by displaying the **OK** prompt.
  - The Pendant screen displays **FAILED** before the **OK** prompt, indicating that the calibration was not successful. This could be the result of a defective or contaminated thermocouple gauge, or that the actual pressure was substantially greater than 1 mTorr.

If the calibration was:

- Not successful, contact Varian Vacuum Technologies Customer Service at 1-800-8VARIAN.
  - Successful, proceed to step 5.
5. Perform the next part of the calibration procedure (“Atmospheric Calibration”).

### 4.2.8.4.2 Atmospheric Calibration

Calibration of the system pressure thermocouple (TC2) gauge to atmosphere is only required if the system TC2 gauge is replaced or if the calibration appears to be off.



*Do not replace the side panels before performing this procedure. You need access to the turbo pump.*

To calibrate the system pressure thermocouple (TC2) gauge to atmosphere:

1. Once the system thermocouple (TC2) has been replaced and before powering up the leak detector, turn off the ROUGH pump and DETECTOR switches.
  2. Turn on the power switch located on the rear panel of the 947/948/960.
  3. Wait for the system NOT READY LED to illuminate.
  4. Open the turbo vent screw located on the side of the turbo pump housing.
  5. On the Service Pendant, press shift and the **SY TC ATM** key.
    - The Pendant screen confirms that the calibration was successful by displaying the **OK** prompt.
    - The Pendant screen displays **FAILED** before the **OK** prompt, indicating that the calibration was not successful. This could be the result of a defective or contaminated thermocouple gauge, or that the actual pressure was not at or near atmosphere.
- If the calibration was not successful, contact Varian Vacuum Technologies Customer Service at 1-800-8VARIAN.
6. If the calibration was successful:
    - Close the turbo vent screw.
    - Replace any panels that were previously removed.

Calibration of the TC2 gauge is complete. You can now proceed with testing or place the system in the mode you desire.

### 4.2.8.5 Test Port Pressure Gauge (TC1) Calibration

This procedure allows for calibration of the test port pressure thermocouple gauge (TC1). Both the Vacuum and Atmospheric Calibrations procedures must be performed in the order written. The vacuum calibration is factory set. Do not change this setting unless you have the appropriate equipment.



*The calibration of the test port thermocouple (TC1) gauge is factory set and requires the use of a reference TC and a PC.*

### 4.2.8.6 Vacuum (Low Pressure) Calibration

To perform this procedure:

1. Verify that the leak detector is in the READY condition (the NOT READY LED is *not* illuminated) and that the test port plug is in place.
2. If the system is not already in VENT mode, press the **VENT** button and verify that the VENT LED is illuminated.
3. Remove the plug from the test port and place a T-Manifold (1 1/8 inches [28 mm] OD) into the test port.
4. Attach a Tuning Leak (Varian P/N K1608301) and a 531 Thermocouple Gauge Tube (Varian P/N F0472301) as a reference TC to the T-manifold.
5. Connect the reference TC to an 801 Thermocouple Gauge Controller.  
For 120 VAC, order Varian P/N F2739301; for 230 VAC, order Varian P/N F2739302.
6. Wait approximately five minutes for the vacuum system pressure to stabilize.
7. Adjust the Tuning Leak to 100 mTorr as indicated by the Varian 801 and verify that the test port pressure on the test port pressure graph reads 1.0E-01 Torr.
8. Connect a PC to J1 inside the turret in place of the Service Pendant.

If using HyperTerminal (or equivalent), establish communication with the leak detector.

Refer to:

- ❑ "Communications Protocol" on page C-1 for the communication parameter setup
- ❑ "Inputs and Outputs" on page D-1
- ❑ "Service Serial Interface (J1)" on page D-1



9. Type `XYZZY<CR>`, then `100 INIT-TPTCZERO<CR>`.
  - The system should respond **OK**.
  - The test port pressure on the test port pressure bar graph should read 1.0E-01 Torr.

A **FAILED** response on the PC is an indication that the calibration was not successful. This could be the result of a defective or contaminated thermocouple gauge. If necessary, replace the thermocouple gauge.

If after replacing the thermocouple gauge, calibration is still not successful, contact Varian Vacuum Technologies Customer Service at 1-800-8VARIAN.
10. If the calibration was successful:
  - Press the **VENT** button and remove the T-manifold, tuning leak, and reference TC from the test port.
  - Place test port plug into the test port and tighten the test port tightening nut fully.
  - Remove the PC and connect the Service Pendant.
  - Perform the next part of the calibration procedure (“Atmospheric Calibration”).

### 4.2.8.7 Atmospheric Calibration

To perform atmospheric calibration:

1. If the system is not already in VENT mode, press the **VENT** button and verify that the VENT LED is illuminated.
2. Wait approximately ten seconds for the test port pressure to stabilize.
3. On the Service Pendant, press the **TP TC ATM** key.
  - The Pendant screen confirms that the calibration was successful by displaying the **OK** prompt.
  - The Pendant screen displays **FAILED** before the **OK** prompt, indicating that the calibration was not successful. This could be the result of a defective or contaminated thermocouple gauge, or that the actual pressure was not at or near atmosphere

If the calibration was:

- Not successful, contact Varian Vacuum Technologies Customer Service at 1-800-8VARIAN.
- Successful, calibration of the TC1 gauge is complete. You can now proceed with testing or place the system in the mode you desire.

## 4.2.9 Rough Pump and Forepump Oil Level Check (Oil-sealed Mechanical Pumps)

Both the Rough pump and Forepump are equipped with an oil level sight glass that can be viewed when the front lower panel cover is removed (Figure 4-12). Refer to your pump manual for the proper oil level. If it is low, fill it to the proper level with Varian Vacuum Technologies' pump oil (part no. 695409005).

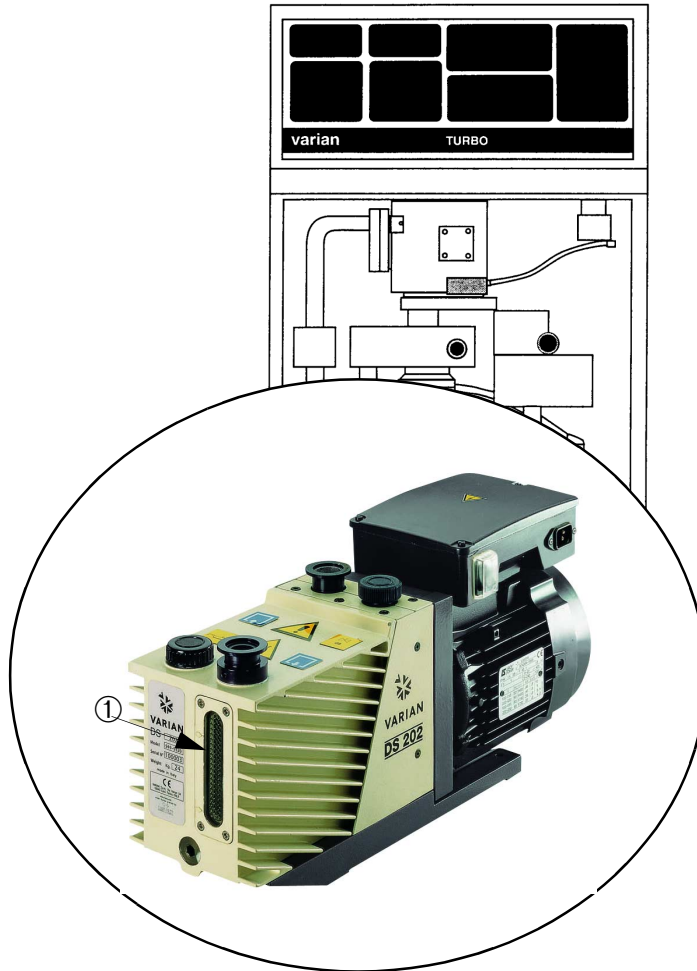

**Figure 4-12 Rough Pump and Forepump Oil Level Check**

① Oil level view port

### 4.2.9.1 Condition of Oil (Oil-sealed Mechanical Pumps)

Excess water in the oil of the Rough pump or the Forepump is indicated by a milky or frothy appearance. Refer to your pump manual for instructions.

### 4.2.10 Cleaning the Test Port

The test port is located at the front center of Models 947/948/960. Thus, it is not necessary to turn the leak detector off or disconnect it from mains power if this is the only procedure being performed. If you are cleaning the test port in conjunction with other procedures that require opening the leak detector, be sure to turn the leak detector off, disconnect it from mains power, and for **Models 948/960**, remove and empty the cold trap.

#### 4.2.10.1 Removing the Test Port

##### CAUTION



*If cleaning the test port in conjunction with performing other service procedures, turn the leak detector off, disconnect mains power, and for **Models 948/960**, remove and empty the cold trap. Heed all warnings and cautions in the Preface of this manual.*

To remove the test port:

1. Turn the test port tightening nut counterclockwise to loosen it (Figure 4-13), then remove the tightening nut and the test port plug.

##### CAUTION



*Be careful not to drop the test port plug when you remove the test port tightening nut. It is deceptively heavy for its size.*



**Figure 4-13 The Test Port**

2. Remove the test port compression ring and O-ring from the top of the test port (Figure 4-14).



**Figure 4-14 Remove the Test Port Compression Ring and O-ring**

### 4.2.10.2 Examining and Cleaning the Test Port

To perform this procedure:

1. Remove the O-ring from the compression ring.
2. Examine the O-ring for wear. If necessary, use a new O-ring, otherwise clean the O-ring.

**NOTE**



*Varian Vacuum Technologies recommends replacing all O-rings during routine maintenance or during any maintenance procedure requiring that O-rings be removed.*

3. Before re-using O-rings or installing new O-rings, wipe them down with a lint-free cloth before installation to ensure that no foreign matter is present to impair the seal.
4. If applicable, apply a small amount of Apiezon L grease and wipe the O-rings “shiny” dry.

**CAUTION**



*Remove O-rings carefully with your fingers. Do not use metal tools for this task. This prevents scratching of any sealing surfaces.*

*Do not use alcohol, methanol or other solvents on O-rings. To do so causes deterioration and reduces their ability to hold a vacuum.*

5. Examine all parts of the test port, including inside the test port.

If necessary, use a VacuSolv wipe to remove any dirt or foreign matter and allow parts to air dry.

### 4.2.10.3 Replacing the Test Port

To replace the test port:

1. Place the O-ring into the groove of the compression ring.
2. Place the compression ring and O-ring onto the top of the test port (Figure 4-15).



**Figure 4-15** Placing the O-ring and Compression Ring onto the Test Port

3. Place the test port tightening nut onto the test port and turn it clockwise until it is just tight enough to stay in place.
4. Place the test port plug into the test port tightening nut, making sure it is completely seated.
5. Tighten the test port tightening nut completely.

## 4.3 Spare Parts

Spare and exchange parts are available in the kits listed on the following pages. Contact Varian Vacuum Technologies to order parts at 1-800-8VARIAN.

### 4.3.10.4 Exchange Assemblies



*Varian Vacuum Technologies will not accept any part for return without both a properly completed Return Materials Authorization (RMA) and a Health and Safety Data Sheet. Contact Customer Service at 1-800-8VARIAN to obtain an RMA and a Health and Safety Data Sheet.*

## Models 947, 948 and 960 Leak Detectors Operations and Service Manual

Table 4-4 lists the exchange assembly parts.

**Table 4-4 Exchange Assembly Parts**

Section	Description	Part Number
Spectrometer Tube	Re-gaussed Magnet	GGK9814301
	Re-built Spec Tube	GGK9735301
Vacuum System	V70 Turbo Pump	9699358
	V70D MacroTorr Pump	9699362
	Turbo Controller	9699840LL

### 4.3.10.5 Replacement Parts

Table 4-5 lists the spare parts available for the 947/948/960.

**Table 4-5 Replacement Parts**

Part	Part Number	Where Used
Spectrometer Tube Assembly	K9735301	947/948/960
Service Block (piece part)	R0028001	947/948/960
Main Block (piece part)	K9614301	947/948/960
Gross Leak Assembly	R1498301	947/948/960
Magnet Yoke Assembly	K9814301	947/948/960
Cold Trap Assembly	L9472301	948/960
Vacuum Valve	K9615301	947/948/960
Solenoid, 2-way, 24 VDC, (V3 or V4)	626571010	947/948/960
Brass Valve, 3-way, 24 VDC, (V5 or V6)	626531260	947/948/960
Solenoid, Gross Leak	626571001	947/948/960
Valve, Nupro, Needle, Gross Leak	626628023	947/948/960
Solenoid, 24 VDC (V8 or V9)	626571017	947/948/960
Ion Source – An ion source with dual-thoriated iridium pre-aligned filaments.	82850302	947/948/960

Tablelle 4-6 enthält eine Liste der auswechselbaren Bauteile.

**Tablelle 4-6 Auswechselbare Bauteile**

Abschnitt	Beschreibung	Teilnummer
Spektrometerrohr	Neu gegaußter Magnet	GGK9814301
	Erneueres Spek.rohr	GGK9735301
Vakuumsystem	V70 Turbopumpe	9699358
	V70D MacroTorr Pumpe	9699362
	Turbo-Steuereinheit	9699840LL

### 4.3.10.6 Ersatz teile

Tablelle 4-7 enthält eine Liste von verfügbaren Ersatzteilen für die 947/948/960.

**Tablelle 4-7 Ersatzteile**

Teil	Teilnummer	Einsatzort
Spektrometerrohr-Einheit	K9735301	947/948/960
Wartungsblock (Teilstück)	R0028001	947/948/960
Hauptblock (Teilstück)	K9614301	947/948/960
Grobleck-Einheit	R1498301	947/948/960
Magnetjoch-Einheit	K9814301	947/948/960
Kühlfallen-Einheit	L9472301	948/960
Vakuumventil	K9615301	947/948/960
Solenoid, 2-Weg, 24 VDC (V3 oder V4)	626571010	947/948/960
Messingventil, 3-Weg, 24 VDC (V5 oder V6)	626531260	947/948/960
Solenoid, Grobleck	626571001	947/948/960
Ventil, Nupro, Nadel, Grobleck	626628023	947/948/960
Solenoid, 24 VDC (V8 oder V9)	626571017	947/948/960
Ionenquelle – eine Ionenquelle mit vorjustiertem, doppeltem Wolframglühfaden mit Thorzusatz	82850302	947/948/960





## Section 5. Troubleshooting

This section explains how to solve common problems with your Leak Detector, by listing symptoms, possible causes, and actions that will correct the problem. The system automatically lists error conditions in Table 5-1 on page 5-2 on the Leak Rate Exponent display, item 9 in Figure 1-3 on page 1-6.

To begin:

- ❑ Verify that the leak detector is plugged into an appropriately powered and properly grounded receptacle.
- ❑ Verify that all plugs and connectors are firmly seated (spectrometer tube, electronic cables, pumps, and power supplies).

For information about pumps shipped with your 947/948/960, refer to the pump manual that came with your 947/948/960 leak detector.

## 5.1 Error Condition Codes

Use Table 5-1 to identify the problem by condition code or Figure 5-2 to identify the symptom.

**Table 5-1 Error Condition Codes**

Code	Problem Area	Solution
c0	Amplifier offset out of range.	Spectrometer Tube Amplifier needs service. Notify Varian Vacuum Technologies Customer Service.
c2	Rough pump is off.	Check power to pump, check switch position, then refer to pump manual.
c4	No emission	Select the other ion source filament. Refer to Section 4, "Maintenance". Replace ion source if necessary.
c5	Auto calibrate function is out of range	Leak detector requires maintenance. Notify Varian Vacuum Technologies Customer Service.
c6	Auto tune function is out of range	Tap the <b>AUTO CAL</b> button. A brief tap may clear this code to allow the leak detector to operate. If this clears <b>c6</b> then the leak detector is operable. If <b>c5</b> appears with <b>c6</b> it is the priority condition code. Press <b>VENT</b> to clear.
c7	Auto Zero function is out of range	Leak detector requires maintenance. Notify Varian Vacuum Technologies Customer Service.
c8	Power interruption	Calibrate the 947/948/960. This condition code may be accompanied by an intermittent <b>c9</b> indication. After a power interruption, wait at least as long as the power interruption (up to 30 minutes) before initiating the calibration procedure.
c9	System pressure is too high	Check for vacuum leaks. Refer to Section 4, "Maintenance".

**NOTE**



*A c6 condition code means that maintenance of this leak detector may soon be necessary. Notify Varian Vacuum Technologies Customer Service at 1-800-8VARIAN.*

## 5.2 Troubleshooting Symptoms and Solutions

Table 5-2 lists the particular symptoms encountered when troubleshooting the leak detector. For every symptom, there is a list of possible causes and actions you can take to remedy the situation.

**Table 5-2 Troubleshooting**

Symptom	Check For	Corrective Action
Leak Detector fails to transfer to the TEST mode	Leak at an inlet line in the vacuum system.	Fix leak.
	Forepump oil discolored or froth on top of oil.	Check for leak, fix, then change the oil. Refer to pump manual if conditions occur again.
	Forepump oil discolored or froth on top of oil <i>and</i> a reading of 100 mTorr on the Test Port Pressure gauge.	Dirty oil. Change oil. Refer to pump manual.
		Check for leak, fix, then change the oil and flush the Rough pump or Forepump.
		Dirty TC gauge. Detector won't read correctly, high test port pressure reading. Clean TC gauge. If problem persists, replace TC gauge.
<b>Models 948/960 only:</b> Excessive moisture in the cold trap	Dry out the cold trap. A warm-up period is necessary.	
Electrical Components: No power, no lights on panel	ON/OFF switch of the rear panel is not ON.	Verify that the switch is ON.
	Power cable is disconnected.	Verify that the power cable is plugged in.
	Source power receptacle is bad.	Route to a new receptacle or fix the old one.
	Circuit breaker is tripped.	Reset the breaker and check for the initial problem.
Fans and Heater: not operational	Circuit breaker is tripped.	Reset the breaker and check for initial problem.
	Fan cord is not properly connected.	Plug in. Verify that the cord is not frayed or loose.
	Heater cord is not properly connected.	Plug in. Verify that the cord is not frayed or loose.
Mechanical Components: Pumps not running	Power cord is disconnected.	Check pump power cords and that 947/948/960 power cord is plugged into outlet.
	947/948/960 in STANDBY.	Take out of STANDBY. Rough pump will not run in STANDBY.

Table 5-2 Troubleshooting (Continued)

Symptom	Check For	Corrective Action
Pumps is gurgling	Pump oil is low.	Add oil.
	KF clamps are loose.	Tighten the clamps.
	Forepump manifold or vacuum lines are leaking.	Check for leaks.
	Pump drain plugs are loose.	Tighten the drain plugs.
Turbo pump not running	No power.	Check the outlets, power switch, and circuit breakers.
	Leaks.	Tighten KF clamps.
		Check the Forepump manifold or vacuum lines for leaking.
		Verify that the system pressure bar graph is at minimum.
		Verify that the thermocouple gauges TC1 and TC2 are in place and secure.
		Verify that the hand operated valve is closed. For normal operation, it must be closed.
Check all valves, vacuum lines, connectors and vacuum seals for proper operation. Any leak or break in vacuum integrity can cause abnormal operation.		

Call Varian Vacuum Technologies Customer Service for any other problems.



*Varian Vacuum Technologies will not accept any part for return without both a properly completed Return Materials Authorization (RMA) and a Health and Safety Data Sheet. Contact Customer Service at 1-800-8VARIAN to obtain an RMA and a Health and Safety Data Sheet.*

## 5.3 Fehlerzustandscodes

Identifizieren Sie das Problem nach Zustandscode unter Bezugnahme auf Table 5-3 oder das Symptom unter Bezugnahme auf Tabelle 5-4.

**Tabelle 5-3 Fehlerzustandscodes**

Code	Problembereich	Lösung
c0	Verstärker-Offset außerhalb des Bereichs	Der Spektrometerrohr-Verstärker muss gewartet werden. Setzen Sie sich mit dem Kundendienst von Varian Vacuum Technologies in Verbindung.
c2	Grobovakuumpumpe ist ausgeschaltet	Prüfen Sie den Stromanschluss der Pumpe und die Schalterposition. Nehmen Sie dann Bezug auf das Pumpenhandbuch.
c4	Keine Emission	Wählen Sie einen anderen Ionenquellen-Glühfaden aus. Siehe to Abschnitt 4, "Maintenance". Bei Bedarf muss die Ionenquelle ersetzt werden.
c5	Automatische Kalibrierung liegt außerhalb des Bereichs	Der Lecksucher muss gewartet werden. Setzen Sie sich mit dem Kundendienst von Varian Vacuum Technologies in Verbindung.
c6	Automatische Feineinstellung liegt außerhalb des Bereichs	Klopfen Sie leicht auf die <b>AUTO CAL</b> Taste. Ein kurzes Klopfen kann diesen Fehlerzustand beheben und den Betrieb des Lecksuchers ermöglichen. Wird der Fehlerzustand <b>c6 dadurch behoben</b> , ist der Lecksucher einsatzbereit. Erscheint <b>c5</b> mit <b>c6</b> handelt es sich um den Prioritätszustandscode. Drücken Sie <b>VENT</b> , um den Zustand zu beheben.
c7	Automatische Nulleinstellung liegt außerhalb des Bereichs	Der Lecksucher muss gewartet werden. Setzen Sie sich mit dem Kundendienst von Varian Vacuum Technologies in Verbindung.
c8	Stromunterbrechung	Kalibrieren Sie die 947/948/960. Dieser Zustandscode wird u.U. von einer intermittierenden Anzeige von <b>c9</b> begleitet. Warten Sie nach einem Stromausfall mindestens so lange wie der Stromausfall (bis zu 30 Minuten), bevor die das Kalibrierungsverfahren einleiten.
c9	Systemdruck ist zu hoch	Untersuchen Sie das System auf Vakuumlecks. Siehe Section 4, "Maintenance".

**HINWEIS**



*Ein c6 Zustandscode bedeutet, dass in Kürze eine Wartung des Lecksuchers erforderlich ist. Wenden sie sich unter der Nummer 1-800-8VARIAN an den Kundendienst von Varian Vacuum Technologies.*

## 5.4 Symptome und Lösungen bei der Fehlersuche

Table 5-4 enthält eine Liste spezifischer Symptome, die bei der Fehlersuche am Lecksucher auftreten können. Für jedes Symptom wird eine Liste möglicher Ursachen und Maßnahmen zur Behebung der Situation aufgeführt.

**Tabelle 5-4 Fehlersuche**

Symptom	Prüfung	Korrektive Maßnahme
Lecksucher geht nicht auf den Prüfmodus über	Leck an einer Einlassleitung im Vakuumsystem.	Beseitigen Sie das Leck.
	Das Öl der Vorvakuum Pumpe ist verfärbt oder auf der Oberfläche des Öls hat sich Schaum gebildet.	Untersuchen Sie auf Lecks, beheben Sie gefundene Lecks und wechseln Sie dann das Öl. Tritt der Zustand erneut auf, nehmen Sie Bezug auf das Pumpenhandbuch.
	Das Öl der Vorvakuum Pumpe ist verfärbt oder auf der Oberfläche des Öls hat sich Schaum gebildet <i>und</i> auf dem Prüfport-Druckmesser wird 100 mTorr angezeigt.	Schmutziges Öl. Wechseln Sie das Öl. Siehe Pumpenhandbuch.
		Untersuchen Sie auf Lecks, beheben Sie gefundene Lecks, wechseln Sie dann das Öl und spülen Sie dann die Grob- oder Vorvakuum Pumpe durch.
	Schmutziges TC-Messgerät. Lecksucher ermittelt keine richtigen Wert, hoher Prüfport-Druckwert. Reinigen Sie das TC-Messgerät. Kann das Problem so nicht behoben werden, ersetzen Sie das TC-Messgerät.	
<b>Nur Modelle 948/960:</b> Übermäßige Feuchtigkeit in der Kühl falle.	Trocknen Sie die Kühlfalle. Eine Erwärmungszeit ist erforderlich.	

Tablelle 5-4 Fehlersuche (Continued)

Symptom	Prüfung	Korrektive Maßnahme
Elektrische Komponenten Kein Strom, keine Lampen an der Schalttafel	ON/OFF Schalter an der rückseitigen Schalttafel steht nicht auf ON.	Vergewissern Sie sich, dass der Schalter auf ON steht.
	Netzkabel ist nicht angeschlossen.	Vergewissern Sie sich, dass das Netzkabel angeschlossen ist.
	Netzstrom-Steckdose ist schadhaft.	Bringen Sie eine neue Steckdose an oder reparieren Sie die alte.
	Trennschalter wurde ausgelöst.	Stellen Sie den Trennschalter zurück und ermitteln Sie den Grund für die Auslösung.
Gebläse und Heizer: nicht betriebsbereit	Trennschalter wurde ausgelöst.	Stellen Sie den Trennschalter zurück und ermitteln Sie den Grund für die Auslösung.
	Gebläsekabel ist nicht richtig angeschlossen.	Schließen Sie das Kabel an. Vergewissern Sie sich, dass es nicht ausgefranst oder locker ist.
	Heizerkabel ist nicht richtig angeschlossen.	Schließen Sie das Kabel an. Vergewissern Sie sich, dass es nicht ausgefranst oder locker ist.
Mechanische Komponenten: Pumpen laufen nicht.	Netzkabel ist nicht angeschlossen.	Prüfen Sie die Pumpennetzkabel und dass die Netzkabel der 947/948/960 richtig angeschlossen sind.
	947/948/960 im Bereitschaftsmodus..	Schalten Sie den Bereitschaftsmodus aus. Die Grobvakuumpumpe kann im Bereitschaftsmodus nicht in Betrieb genommen werden.
Die Pumpen gurgeln.	Ölstand in den Pumpen ist niedrig.	Füllen Sie Öl nach.
	KF-Klemmen sind locker.	Ziehen Sie die Klemmen an.
	Vorvakuum pumpen-Manifold oder Vakuumleitung ist undicht.	Untersuchen Sie das System auf Lecks.
	Ablasstecker der Pumpen sind locker.	Stellen Sie die Ablasstecker fest.

Tablelle 5-4 Fehlersuche (Continued)

Symptom	Prüfung	Korrektive Maßnahme
Turbopumpe läuft nicht.	Kein Strom.	Prüfen Sie Ausgänge, Stromschalter und Trennschalter.
	Lecks	Ziehen Sie die KF-Klemmen an.
		Vorvakuumumpumpen-Manifold oder Vakuumleitung ist undicht.
		Verifizieren Sie, dass das Systemdruck-Balkendiagramm den Mindestwert anzeigt.
		Verifizieren Sie, dass die Thermoelement-Messgeräte TC1 und TC2 angebracht und sicher sind.
		Verifizieren Sie, dass das handbetätigte Ventil geschlossen ist. Für den Normalbetrieb muss es geschlossen sein.
		Prüfen Sie alle Ventile, Vakuumleitungen, Anschlüsse und Vakuumdichtungen auf ihren vorschriftsmäßigen Betrieb. Ein Leck oder Bruch in der Vakuumintegrität kann einen anormalen Betrieb zur Folge haben.

Beim Auftreten anderer Probleme wenden Sie sich bitte an den Kundendienst von Varian Vacuum Technologies.

**HINWEIS**



*Varian Vacuum Technologies verweigert die Annahme eines zurückgesendeten Teils ohne das vorschriftsmäßig ausgefüllte Formular Return Materials Authorization (RMA) und ein Gesundheits- und Sicherheitsdatenblatt. Ein RMA und Gesundheits- und Sicherheitsdatenblatt ist vom Kundendienst unter 1-800-8VARIAN erhältlich.*



# Appendix A. Service Pendant Keypad Functions

## A.1 Keypad Functions

Figure A-1 shows the service pendant keypad.

“Glossary of Function Keys” on page A-3 explains the keys that perform special functions when entering information. “Glossary of Input and Data Keys” on page A-3 explains the remaining keys which are used to input or show data.

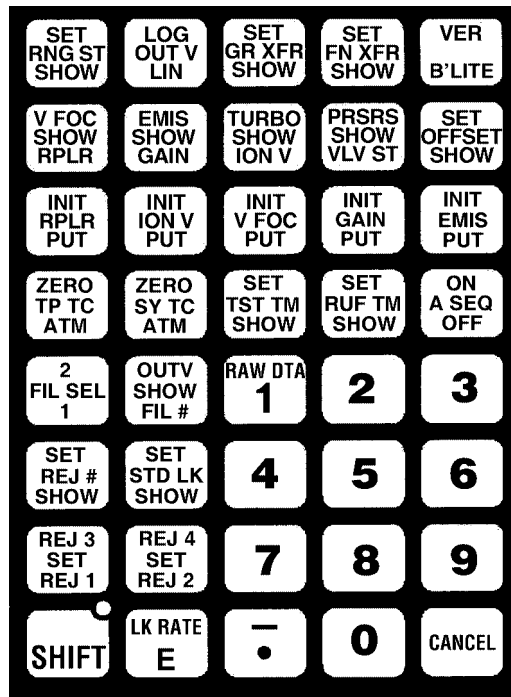

Figure A-1 Service Pendant Keypad

### A.1.1 Using the Service Pendant

Each function is printed in black in the center of the key (for example, REJ#). Some functions require the input of a number before the function key is pressed. Other functions, such as queries, do not require any numeric input. The operation to be performed in the functional category is printed in either blue (i.e., ATM on the lower part of the key), or red (i.e., ZERO on the upper part of the key).

#### Reject Set Point Example

Four individual reject set points can be set, but only one reject set point is enabled at a time.

To set a reject set point value and make it the active reject set point:

1. Display (show) the existing reject set point value and see if it is enabled (on or off).
  - Press **1** (the number of the reject set point you want to display, i.e., 1 though 4)
  - Press:



The currently enabled set point is displayed along with its value and **on** or **off**. **On** indicates that the displayed set point is enabled.

2. Set reject set point 1 value to 5.5E-5.



*The pendant will display exponential values to 2 characters. However, the single digit (in this case 5) or both digits (05) are valid entries.*

- Press the following keys in order from left to right to enter the value:

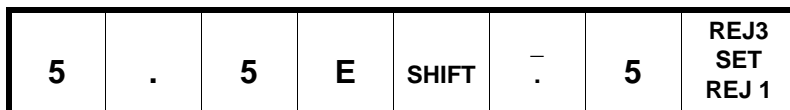

The system displays **INIT**, followed by the value, and ends the string with **ok**.

3. Enable reject set point 1 (make it the active reject set point).
  - Press the following keys in order from left to right to enable reject set point 1:

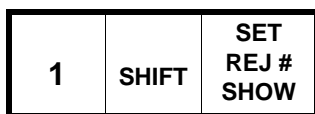

The pendant displays the reject set point, its value, and **on** to indicate reject set point 1 is enabled.

## A.2 Glossary of Function Keys

	<b>SHIFT</b>	Performs the red function on the key pressed after the SHIFT key.
	<b>LK RATE E</b>	Enters the <b>E</b> for exponential notation inputs such as reject set point.
<b>[SHIFT]</b>	<b>LK RATE E</b>	Displays the current leak rate.
	<b>.</b>	Enters a . (decimal point) for input values such as in rangestop.
<b>[SHIFT]</b>	<b>-</b>	Enters a - (minus sign) for negative input values such as in rangestop.
	<b>CANCEL</b>	Erases an entry if a mistake is made.
	<b>All digits from 2 to 9 and zero.</b>	Enters the digit pressed.
	<b>RAW DTA 1</b>	Enters the digit 1.

## A.3 Glossary of Input and Data Keys

The keys listed below start at the top of the keypad and continue from left to right.

	<b>SET RNG ST SHOW</b>	Displays the value of the range stop, the lowest decade that the leak detector will show on the bar graph.
<b>[SHIFT]</b>	<b>SET RNG ST SHOW</b>	Sets the value of the range stop, the lowest decade that the leak detector will show on the bar graph. Enter -XX (the desired value), followed by the SHIFT and the function key.
	<b>LOG OUT V LIN</b>	Sets the analog leak rate output voltage on the rear panel to Linear format.
<b>[SHIFT]</b>	<b>LOG OUT V LIN</b>	Sets the analog leak rate output voltage on the rear panel to 2 V / Decade Log format.
	<b>SET GR XFR SHOW</b>	Displays the value of the Gross Leak Transfer Point.

## Models 947, 948 and 960 Leak Detectors Operations and Service Manual

---

[SHIFT]	SET GR XFR SHOW	Sets the value of the Gross Leak Transfer Point. Enter X.XE-X (the desired value), followed by SHIFT, then the function key. Example: 5.0E-2 [SHIFT] SET GR XFER (sets Gross Leak Transfer to 50 mTorr).
	SET FN XFR SHOW	Displays the value of the Fine Leak Transfer Point.
[SHIFT]	SET FN XFR SHOW	Sets the value of the Fine Leak Transfer Point. Enter X.XE-X (the desired value), followed by SHIFT, then the function key.
	VER B'LITE	Switches the display backlight. If on, turns it off. If off, turns it on.
[SHIFT]	VER B'LITE	Displays the version date and checksum of the installed software.
	V FOC SHOW RPLR	Displays the value of the Repeller Voltage in the Ion Source.
[SHIFT]	V FOC SHOW RPLR	Displays the value of the Variable Focus Voltage in the Ion Source.
	EMIS SHOW GAIN	Displays the value of the System Gain.
[SHIFT]	EMIS SHOW GAIN	Displays the value of the Emission Current in the Ion Source.
	TURBO SHOW ION V	Displays the value of the Ion Voltage in the Ion Source.
[SHIFT]	TURBO SHOW ION V	Displays the status of the Turbo Pump in the leak detector.
	PRSR SHOW VLV ST	Displays the present valve mode of the leak detector.

## Models 947, 948 and 960 Leak Detectors Operations and Service Manual

---

[SHIFT]	<b>PRSR SHOW VLV ST</b>	Displays the Test Port and System Pressures.
	<b>SET OFFSET SHOW</b>	Displays the value of the electronic offset in the Preamplifier.
[SHIFT]	<b>SET OFFSET SHOW</b>	Sets a temporary value of the electronic offset in the Preamplifier. Enter XX (the desired value), followed by the SHIFT key, then the function key.
	<b>INIT RPLR PUT</b>	Sets a temporary new value for Repeller Voltage. Enter XXX (the desired value), then the function key.
[SHIFT]	<b>INIT RPLR PUT</b>	Sets a permanent new value for Repeller Voltage. Enter XXX (the desired value), followed by the SHIFT key, then the function key.
	<b>INIT ION V PUT</b>	Sets a temporary new value for Ion Voltage. Enter XXX (the desired value), then the function key.
[SHIFT]	<b>INIT ION V PUT</b>	Sets a permanent new value for Ion Voltage. Enter XXX (the desired value), followed by the SHIFT key, then the function key.
	<b>INIT V FOC PUT</b>	Sets a temporary new value for Variable Focus Voltage. Enter XXX (the desired value), then the function key.
[SHIFT]	<b>INIT V FOC PUT</b>	Sets a permanent new value for Variable Focus Voltage. Enter XXX (the desired value), followed by the SHIFT key, then the function key.
	<b>INIT GAIN PUT</b>	Sets a temporary new value for System Gain. Enter X.X (the desired value), then the function key.
[SHIFT]	<b>INIT GAIN PUT</b>	Sets a permanent new value for System Gain. Enter X.X (the desired value), followed by the SHIFT key, then the function key.
	<b>INIT EMIS PUT</b>	Sets a temporary new value for Emission Current. Enter XXXX (the desired value), then the function key.

## Models 947, 948 and 960 Leak Detectors Operations and Service Manual

---

[SHIFT]      **INIT  
EMIS  
PUT**      Sets a permanent new value for Emission Current. Enter XXXX (the desired value), followed by the SHIFT key, then the function key.

**ZERO  
TP TC  
ATM**      Initiates an atmosphere calibration of the Test Port TC.

[SHIFT]      **ZERO  
TP TC  
ATM**      Initiates a zero calibration of the Test Port TC.

**ZERO  
SY TC  
ATM**      Initiates an atmosphere calibration of the System TC.

### NOTE



*System TC being at atmosphere is not a normal state for the leak detector. The turbo pump must be turned off, and the spectrometer tube must be vented by operating the valves or by opening the vent screw on the turbo pump. This is best done before the pump gets up to speed just after turning the leak detector on.*

### CAUTION



*You must take care to avoid damage to the vacuum system and the spectrometer tube. Follow instructions carefully.*

[SHIFT]      **ZERO  
SY TC  
ATM**      Initiates a zero calibration of the System TC.

**SET  
TST TM  
SHOW**      Displays the value of the Auto Sequencer Test Time.

[SHIFT]      **SET  
TST TM  
SHOW**      Sets the value of the Auto Sequencer Test Time. Enter XXX (the desired value), followed by the SHIFT key, then the function key.

**SET  
RUF TM  
SHOW**      Displays the value of the Auto Sequencer Roughing Time.

[SHIFT]      **SET  
RUF TM  
SHOW**      Sets the value of the Auto Sequencer Roughing Time. Enter XXX (the desired value), followed by the SHIFT key, then the function key.

**ON  
A SEQ  
OFF**      Turns off the Auto Sequencer function.

## Models 947, 948 and 960 Leak Detectors Operations and Service Manual

---

[SHIFT]	ON A SEQ OFF	Turns on the Auto Sequencer function.
	2 FIL SEL 1	Selects filament #1 in the Ion Source.
[SHIFT]	2 FIL SEL 1	Selects filament #2 in the Ion Source.
	OUT V SHOW FIL #	Displays the active filament number.
[SHIFT]	OUT V SHOW FIL #	Displays the format of the analog leak rate output voltage.
[SHIFT]	RAW DTA 1	Displays a set of readings from the leak rate A/D conversion.
	SET REJ # SHOW	Displays the active reject set point (1 through 4) and the value of the reject set point.
[SHIFT]	SET REJ # SHOW	Sets the active reject set point. Enter a number from 1 through 4, then press the function key.
	SET STD LK SHOW	Displays the leak rate value to which the leak detector calibrates.
[SHIFT]	SET STD LK SHOW	Sets the leak rate value to which the leak detector calibrates. Enter X.XE-X (the desired value), followed by the SHIFT key, then the function key.
	REJ3 SET REJ 1	Sets the leak rate value for Reject Set Point #1. Enter X.XE-X (the desired value), then the function key.
[SHIFT]	REJ3 SET REJ 1	Sets the leak rate value for Reject Set Point #3. Enter X.XE-X (the desired value), followed by the SHIFT key, then the function key.
	REJ 4 SET REJ 2	Sets the leak rate value for Reject Set Point #2. Enter X.XE-X (the desired value), followed by the SHIFT key, then the function key.
[SHIFT]	REJ 4 SET REJ 2	Sets the leak rate value for Reject Set Point #4. Enter X.XE-X (the desired value), followed by the SHIFT key, then the function key.

*This page intentionally left blank.*



## Appendix B. Parts Replacement

This appendix contains the following parts replacement procedures:

- “Removing the Covers” on page B-1
- “Replacing the Ion Source” on page B-6
- “Turbo Pump” on page B-9
- “Replacing the Rough Pump” on page B-15
- “Replacing the Forepump” on page B-22

### B.1 Removing the Covers

Before opening any part of Models 947/948/960 for service, heed the following:

**WARNING**



*Disconnect power from the 947/948/960 before performing any maintenance procedure that requires physically disconnecting any part of the system.*

**CAUTION**



**Models 948/960 only:** *Remove, empty, and clean the cold trap whenever power is removed. Refer to “Liquid Nitrogen Cold Trap (Models 948/960 only)” on page 4-10,*

**CAUTION**



*Many components of the 947/948/960 are static sensitive devices. Varian Vacuum Technologies recommends that you wear a grounding device when performing any maintenance on the 947/948/960 and especially when performing maintenance of static sensitive parts.*

## B.1.1 Opening the Turret

The turret opens by unlocking and lifting its cover. To remove the top cover, you must remove the shelf that the service pendant sits on.

### B.1.1.1 Removing the Service Pendant Shelf

To remove the service pendant shelf:

1. Loosen the screws of the service pendant serial connection and remove the connection (Figure B-1).

**NOTE**



*The service pendant power cable is still attached to the electronics housed beneath the pendant shelf.*

2. Place the service pendant on the top of the 947/948/960 or on another nearby surface.



**Figure B-1 Removing the Service Pendant Shelf**

3. Use a Phillips head screwdriver to remove the screws located at either side of the shelf.
4. Lift the shelf up and out of the turret.

## B.1.2 Removing the Top Panel

The top panel is one piece that includes the turret and its door, a covering of the sides of the control and display panel, and the stainless steel top of the 947/948/960.

To remove the 947/948/960 top panel:

1. Remove the upper rear panel.
2. If you need access to the electronics enclosure, remove the service pendant shelf using the procedure described in "Removing the Service Pendant Shelf" on page B-2.
3. Remove the 3-8 nuts located under the front corners of the frame of the chassis (Figure B-2).

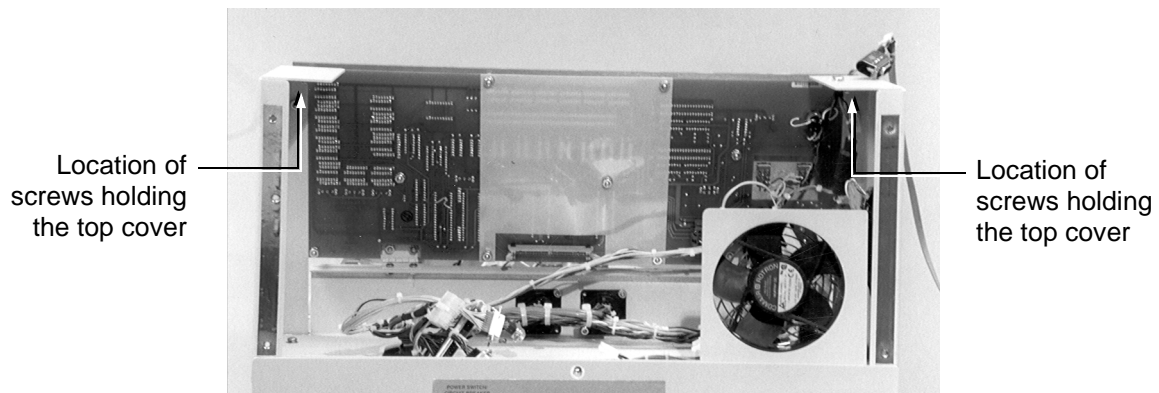

**Figure B-2 The Top Panel at the Rear of the Turret**

4. Loosen the test port tightening nut and remove it.
5. Remove the test port plug (Figure B-3), the test port compression ring and the O-ring from the top of the test port.

### NOTE



*Do not remove the port nut.*



**Figure B-3 The Test Port**

6. Remove the three, 5-16 screws from under the front of the top cover (Figure B-4).

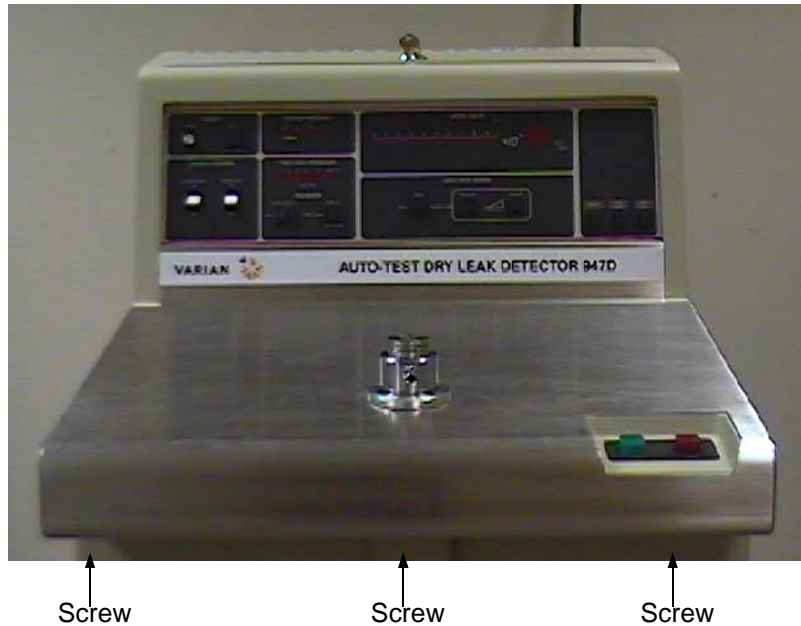

**Figure B-4 The Top Panel from the Front of the 947/948/960**

7. Lift the top panel from the chassis.

### **B.1.3 Replacing all Panels and Covers**

#### **B.1.3.1 Replacing the Service Pendant Shelf**

To replace the service pendant shelf:

1. Place the shelf into the turret guiding the power wire through the area beside the shelf near the serial connection.
2. Replace the screws at either side of the shelf and tighten them using a Phillips head screwdriver.
3. Plug the service pendant serial plug into the connection at the side of the turret and tighten the screw.
4. Place the service pendant into the shelf.
5. Close and lock the turret if necessary.

### B.1.3.2 Replacing the Top Panel

#### WARNING



- ❑ *Be sure power is disconnected from the leak detector before attempting to replace the top cover. The start button could be pressed while maneuvering the cover into place and the leak detector inadvertently started.*
- ❑ *Take care not to catch any wires when replacing the cover.*
- ❑ *Be sure the start and stop buttons have smooth, normal motion and that they are not constrained by the top cover.*

To replace the top panel:

1. Place the top cover onto the frame, fitting it around the front of the chassis, the start and stop button panel, the test port, and the upper back of the turret.
2. Working at the rear of the leak detector, place the two 3-8 nuts onto the screws located in the back corners under the upper frame and tighten them fully.
3. Working from the front of the leak detector, replace the three 5-16 nuts under the front edge of the top cover.
4. If it was removed, replace the service pendant shelf using the procedure described in “Replacing the Service Pendant Shelf” on page B-4.
5. Replace the upper rear panel.

#### NOTE



*While the test port is extracted, i examine it to see if it requires cleaning. See “Examining and Cleaning the Test Port” on page 4-36.*

## B.2 Replacing the Ion Source

If the ion source needs replacement (Figure B-5), replace it during spectrometer tube cleaning. Adjustment is required after replacement is complete. Refer to "Calibration and Sensitivity Checks" on page 3-11 for the adjustment procedures.

**WARNING**



*Store the Ion Source in a cool, dry area in a tightly sealed container. Wash hands thoroughly after handling the Ion Source and especially before smoking or eating.*

**CAUTION**



*Use powder-free butyl or polycarbonate gloves to prevent skin oils from getting on vacuum surfaces.*

To replace the ion source:

1. Remove the spectrometer tube from the leak detector as described in "Removing and Replacing both the Spectrometer Tube Assembly and Preamplifier" on page 4-23.

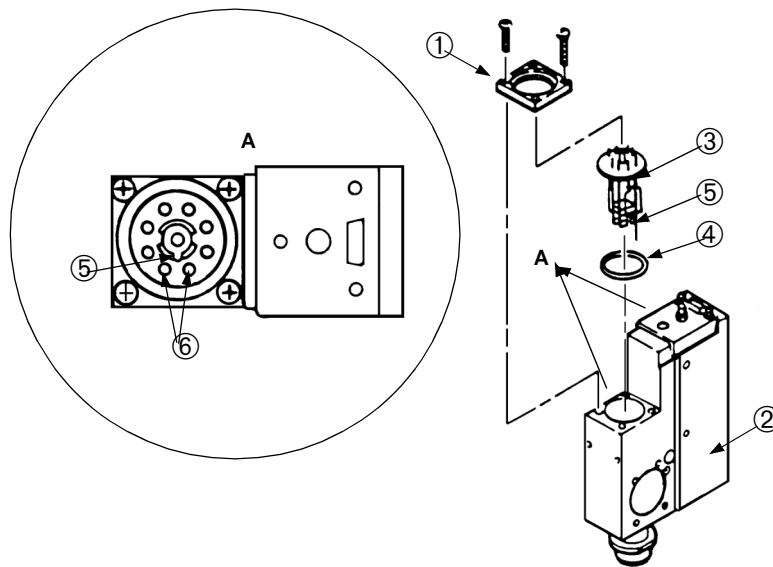

**Figure B-5 Ion Source Replacement**

- Remove the four Phillips head screws that hold the flange cap ① onto the body of the spectrometer tube ② (Figure B-5).
- Firmly but gently separate the flange cap from the ion source ③.
- Remove the ion source.

Examine it and the cavity for deposits and discoloration. If either is discolored or dirty, contact Varian Vacuum Technologies Customer Service at 1-800-8VARIAN.



*Dark carbon deposits around the ion source filament and/or a rainbow-like discoloration on the inside walls of the ion source cavity indicate that the spectrometer tube has been operated at too high a pressure. This can occur from a system pressure leak or transferring into test at too high a pressure.*

- Discard the ion source in accordance with local regulations, or return it to Varian Vacuum Technologies for exchange.
- Remove the ground slit plate by placing a thin, slotted screwdriver into the slot and carefully twisting and prying with the screwdriver.
- Place the ground slit plate on a clean surface.
- Using the Scotch-Brite™ pad from the spectrometer tube cleaning kit, polish away any discolored areas:
  - Inside the spectrometer tube cavity.
  - Discolored areas of the ground slit plate.

**CAUTION**



*The ground slit plate is very thin. Take care not to bend or disfigure it during cleaning.*

- Using the VacuSolv presaturated cleaning wipes and swabs, thoroughly wipe down all surfaces of the spectrometer tube body and the ground slit plate, then let air dry.
- Place the ground slit plate onto the locking screwdriver as you did to remove it, with the prongs facing up.

**CAUTION**



*The ground slit plate must be firmly seated and in proper orientation. Failure to do so can result in unreliable test results.*

11. When installing the ground slit plate, be sure that the snap prongs are facing up.

Align the slit at 90° with the side wall of the spectrometer tube and concentrically align the circular hole in the plate with the smaller guide hole in the bottom of the ion source cavity.

**CAUTION**



*If it is necessary to bend the ground slit plate prongs out, be sure to bend them only slightly so that when it is being inserted, the prongs do not scratch the ion source cavity.*

12. Check that the ground slit plate is firmly seated in the ion source cavity.

If not, remove the ground slit plate and, using a screwdriver, bend the prongs out *slightly*. Then place it into the cavity again.

**CAUTION**



*A short could result at power up if the alignment pin touches the sides of the alignment hole.*

13. Wipe the new O-ring ④ and mating surfaces with a clean, lint-free cloth and place the new ion source in its cavity:

- ❑ Place the locating pin ⑤ so that it falls in the center of the guide hole.
- ❑ Ensure that pins 1 and 8 ⑥ are parallel to the sidewall of the spectrometer tube as shown in Figure B-5 on page B-6, View A.
- ❑ Secure the flange cap evenly and firmly by tightening the four Phillips head screws.

14. Install the spectrometer tube in the leak detector as described in “Reinstalling the Spectrometer Tube” on page 4-23.

15. See “Calibration and Sensitivity Checks” on page 3-11 for electronic calibration procedure.



## B.3 Replacing the Turbo Pump

Models 947/948/960 have one turbo pump and two mechanical pumps: a forepump and a rough pump.

### B.3.1 Turbo Pump

The turbo pump (Figure B-6) is located in the middle front of the main cabinet. You must remove connections to the valve block, spectrometer tube and power to remove the turbo pump.

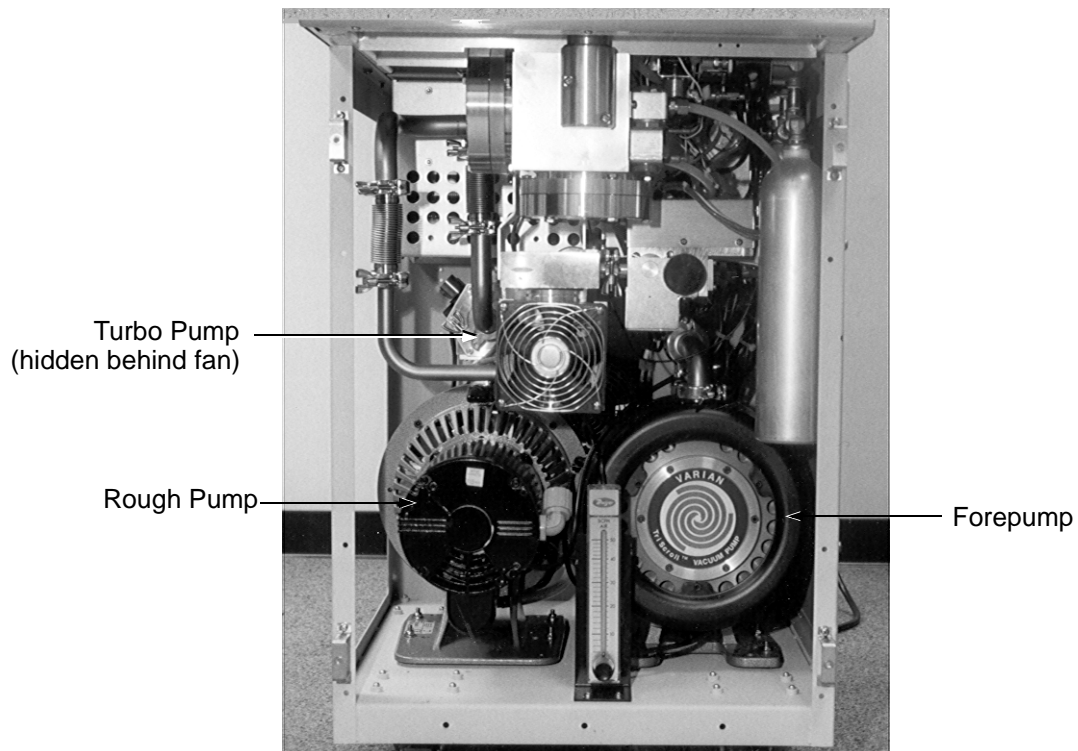

Figure B-6 Location of the Turbo Pump

## B.3.1.1 Removing the Turbo Pump

To replace the turbo pump:

1. Disconnect the mains power supply and make sure that all pumps are off.

### WARNING



*Disconnect power from the 947/948/960 before performing any maintenance procedure that requires physically disconnecting any part of the system.*

### CAUTION



**Models 948/960 only:** Remove, empty, and clean the cold trap whenever power is removed. Refer to "Liquid Nitrogen Cold Trap (Models 948/960 only)" on page 4-10.

2. Remove the side panel.
3. Disconnect the power from the turbo pump by pushing the green sleeve on the end of the connector in and then turning the sleeve to release the connector (Figure B-7).

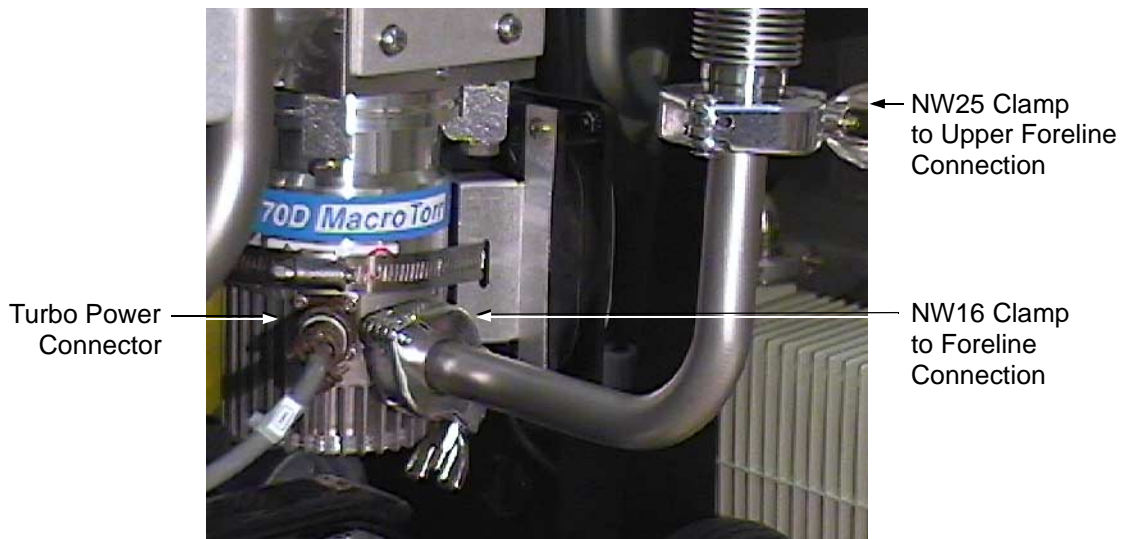

**Figure B-7 Turbo Power and Foreline to Turbo Connections**

4. Follow the power wire from the fan to two pink connectors labeled 1+ and 2-.  
If the connections are not fully labeled, label them now (Figure B-8).



**Figure B-8 The Turbo Power Connection**

5. Loosen the radiator clamp screw and remove the fan from the turbo pump (Figure B-9).

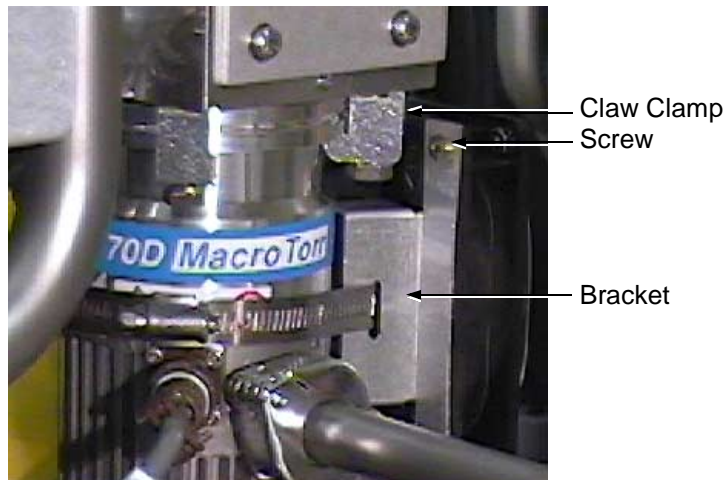

**Figure B-9 Radiator Clamp holding Fan to Turbo**

6. Loosen the wing nut and remove the NW25 clamp that connects the foreline to the turbo (Figure B-7 on page B-10).
7. Remove the centering ring and O-ring and place them on a clean surface.

### CAUTION



*At this point the pump is held solely by the four ISO single claw clamps connected to the Service Valve Block assembly SVBA. When removing the clamps, be sure to support the pump so it does not drop.*

8. Be sure that the turbo pump is supported, then unbolt and remove the four ISO single claw clamps located on the corners of the Service Valve Block assembly (SVBA)

To obtain more space to maneuver the turbo pump:

- ❑ Loosen and remove the NW25 clamp to the upper foreline connection (Figure B-7 on page B-10).
  - ❑ Remove the foreline, centering ring and O-ring and place them on a clean surface.
9. Remove the turbo pump.
  10. Remove the ISO50 centering ring and O-ring and place them on a clean surface.

### B.3.1.2 Replacing the Turbo Pump

Before you replace the turbo pump, examine and clean all O-rings centering rings, clamps and the SVBA.

#### B.3.1.2.1 Examining and Cleaning Centering Rings, O-rings and Manifold

To perform this procedure:

1. Using VacuSolv presaturated cleaning wipes and swabs, thoroughly wipe down all surfaces of the centering rings, clamps, and manifold.

### CAUTION



*Do not clean any aluminum parts with Alconox<sup>®</sup>. Alconox is not compatible with aluminum and will cause damage.*

2. Carefully inspect all O-rings and replace all damaged O-rings.

### NOTE



*Varian Vacuum Technologies recommends replacing all O-rings during routine maintenance or during any maintenance procedure requiring that O-rings be removed.*

3. Before re-using O-rings or installing new O-rings, wipe them down with a lint-free cloth to ensure that no foreign matter is present to impair the seal.

### CAUTION



*Remove O-rings carefully with your fingers. Do not use metal tools for this task. This prevents scratching of any sealing surfaces.*

*Do not use grease or other substances on the O-rings that come in contact with the spectrometer tube.*

*Do not use alcohol, methanol, or other solvents on O-rings. To do so causes deterioration and reduces their ability to hold a vacuum.*

4. Place the O-rings on the centering rings.
5. Using a VacuSolv wipe, clean the SVBA at its connection point to the turbo pump.
6. Allow all parts to air dry thoroughly.

### **B.3.1.2.2 Connecting the Turbo Pump to the SVBA**

To perform this procedure:

1. Place the O-ring on the ISO50 centering ring.
2. Place the centering ring against the top of the turbo pump.
3. Hold the turbo pump against the SVBA oriented so that the flange for the foreline connection is in line with the foreline.
4. While supporting the pump with one hand, place the four ISO single claw clamps onto the corners of the SVBA (Figure B-9 on page B-11), insert the bolts, and then tighten them just enough to hold the pump.
5. If the foreline was removed from the upper foreline connection (Figure B-7 on page B-10), do the following:
  - a. Place the centering ring and O-ring against the flange of the flexible coupling.
  - b. Orient the curved foreline so that the shorter leg is up and the longer leg is in line with the flange on the turbo pump.
  - c. Place the upper end of the foreline against the upper foreline connection centering ring and O-ring.
  - d. Place the NW25 clamp around the centering ring and O-ring and tighten the wingnut fully.
6. Place the O-ring and centering ring against the foreline flange on the turbo pump.

7. Place the foreline against the turbo flange centering ring and O-ring.



*Gently pivot the turbo pump until it is in the position to make the connection without placing stress on the manifold. The claw clamps should be loose enough to allow you to do this.*

8. Place the NW16 clamp onto the connection and tighten the wing nut.
9. Fully tighten the ISO single claw clamps.
10. Connect the turbo pump power by pushing the power connector onto the pump and then turning the green sleeve until the connector locks into place.
11. Connect the mechanical pump power plugs if they are not connected already.
12. Place the turbo fan assembly against the turbo pump, oriented so that the fan is on the front of the pump with the guard facing outward.
13. Place the radiator clamp around the turbo pump. Tighten the radiator clamp screw fully.

**CAUTION**



*To ensure reliable testing, after servicing any part of the vacuum system, the 947/948/960 must be leak checked again. Refer to "Leak Checking" on page 4-5 for guidelines.*

14. Replace the side panel.
15. If the front panel was removed, replace it.
16. Reconnect the mains power supply.
17. Turn the leak detector on and wait for the system to be ready.

Allow the pumps to warm up if the detector has been off for some time.

18. Calibrate the 947/948/960 using the procedure described in "Re-calibrate the Internal Calibrated Leak" on page 4-7.
19. Leak check the assembly before using the 947/948/960 for testing.

## B.4 Replacing the Rough Pump

### B.4.1 Wet Systems

This discussion includes procedures for replacing rough pumps in wet systems (“Removing the Wet System Rough Pump” on page B-16) and rough pumps in dry systems (“Removing the Dry System Rough Pump” on page B-20).

In both cases, the rough pump is mounted on the bottom of the right side of the main cabinet. Figure B-10 shows the front view of wet and dry pump configurations.

#### WARNING



*To avoid injury, use proper lifting techniques when moving pumps. Your system may have pumps that require two people to move them safely.*

Before replacing the rough pump:

- Refer to the appropriate pump operations manual.
- Ensure that the replacement pump is either the same one as you are replacing, or a pump that can be used in its place.

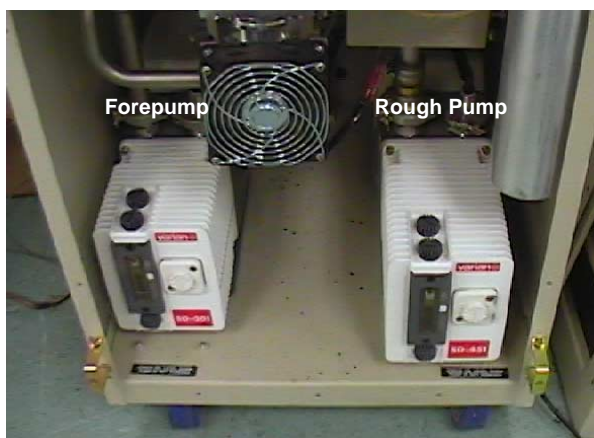

Wet Pump Configuration

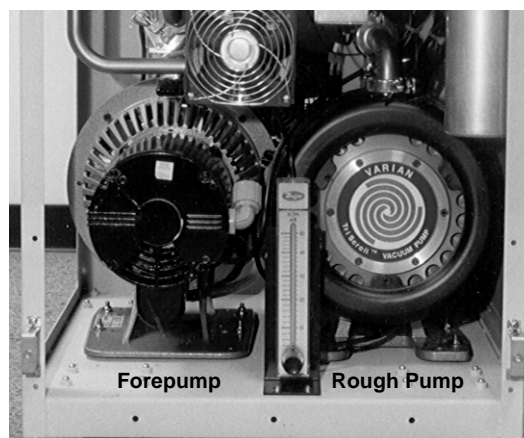

Dry Pump Configuration

Figure B-10 Location of Forepump and Rough Pump — Wet and Dry Configurations

### B.4.1.1 Removing the Wet System Rough Pump

To perform this procedure:

1. Disconnect the mains power supply and make sure that all pumps are off.

#### WARNING



*Disconnect power from the 947/948/960 before performing any maintenance procedure that requires physically disconnecting any part of the system.*

#### CAUTION



**Models 948/960 only:** Remove, empty, and clean the cold trap whenever power is removed. Refer to “Liquid Nitrogen Cold Trap (Models 948/960 only)” on page 4-10.

2. Remove the front panel.
3. Remove the right side panel.
4. Disconnect the pump power plug from the 947/948/960.
5. Drain the oil according to the pump manual instructions.
6. If you are replacing the pump as part of a Varian exchange program, return it in accordance with the program, or discard it in accordance with all applicable regulations.

#### NOTE



*Varian Vacuum Technologies will not accept any part for return without both a properly completed Return Materials Authorization (RMA) and a Health and Safety Data Sheet. Contact Customer Service at 1-800-8VARIAN to obtain an RMA and a Health and Safety Data Sheet.*

7. Remove the NW25 clamp from the left manifold (Figure B-11).



**Figure B-11 Rough Pump Manifold and Exhaust Connections**



8. Remove the centering ring and O-ring and place all connections where the oil will not contaminate other parts.
9. Remove the NW16 clamp from the exhaust connection.
10. Remove the exhaust fitting.
11. If desired, remove the length of tubing from the exhaust fitting.
12. Remove the centering ring and O-ring and place all connections where the oil will not contaminate other parts.
13. Loosen and remove the four nuts and the bolts that connect the pump to the bottom of the main cabinet (Figure B-10 on page B-15).



*You may have to loosen the radiator clamps on the tygon tubing and slide it up the line to remove the pump.*

14. Remove the pump from the 947/948/960.

### **B.4.1.1.1 Replacing the Wet System Rough Pump**

Before you replace the wet mechanical pump, examine and clean all O-rings centering rings, clamps and the manifold.



*There may be oil on these parts. Take care not to place them where other parts may be contaminated.*

### **B.4.1.1.2 Examining and Cleaning Centering Rings, O-rings and Manifold**

Refer to “Examining and Cleaning Centering Rings, O-rings and Manifold” on page B-12. Execute steps 1 through 4.

### B.4.1.1.3 Re-installing the Wet System Rough Pump

#### WARNING



*To avoid injury, use proper lifting techniques when moving pumps. Your system may have pumps that require two people to move them safely.*

To perform this procedure:

1. Ensure the area is clean for the new pump.

#### NOTE



*You may have to loosen the radiator clamps on the tygon tubing and slide it up the line to remove the pump.*

2. Place the new pump into the cabinet aligning the holes in the pump over the mounting holes in the floor of the cabinet.
3. Working from beneath the cabinet, place the bolts into the mounting holes, replace the nuts, but do not tighten them fully.

You may have to shift the pump a bit when making the connections.

4. Place the centering ring and O-ring onto the pump outlet flange on the left side of the pump.
5. Place the manifold against the centering ring.
6. If necessary, slide the Tygon tubing down over the connection and tighten the radiator clamps (Figure B-12).

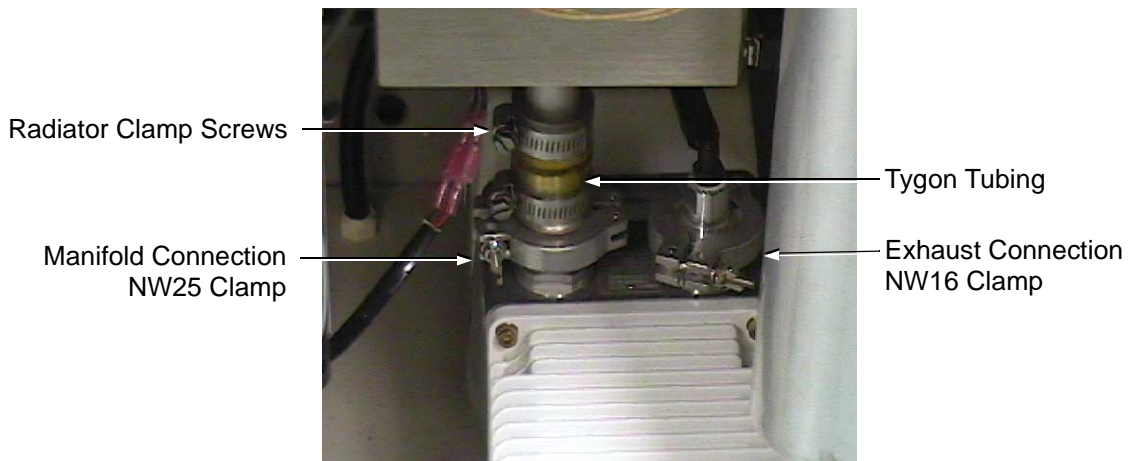

**Figure B-12 Rough Pump Manifold and Exhaust Connections**

7. Place the NW25 clamp onto the connection and tighten fully.
8. Place the centering ring and O-ring against the pump outlet on the right side.
9. Place the exhaust manifold against the centering ring and O-ring.
10. Place the NW16 clamp onto the connection and tighten fully.
11. If you removed the length of tubing from the exhaust connection, replace it now.
12. Working from under the leak detector, place the nuts onto the mounting bolts and tighten them fully.
13. Connect the pump power cord into the 947/948/960.
14. Consult the pump operations manual for any other necessary procedures to be performed before closing the panels or powering up the pump.

### CAUTION



*To ensure reliable testing, after servicing any part of the vacuum system, the 947/948/960 must be leak checked again. Refer to "Leak Checking" on page 4-5 for guidelines.*

15. Replace the front and side panels.
16. Reconnect the mains power supply.
17. Turn the leak detector on and wait for the system to be ready.  
Allow the pumps to warm up if the detector has been off for some time.
18. **Models 948/960 only:** Once the system has pumped down, clean and fill the Liquid Nitrogen Cold Trap using the procedure described in "Liquid Nitrogen Cold Trap (Models 948/960 only)" on page 4-10.  
Follow all warnings and cautions in the procedure.
19. Calibrate the 947/948/960 using the procedure described in "Re-calibrate the Internal Calibrated Leak" on page 4-7.
20. Leak check the assembly before using the 947/948/960 for testing.

### B.4.2 Dry Systems

#### B.4.2.1 Removing the Dry System Rough Pump

To perform this procedure:

1. Disconnect the mains power supply and make sure that all pumps are off.

**WARNING**



*Disconnect power from the 947/948/960 before performing any maintenance procedure that requires physically disconnecting any part of the system.*

**CAUTION**



**Models 948/960 only:** Remove, empty and clean the cold trap whenever power is removed. Refer to “Liquid Nitrogen Cold Trap (Models 948/960 only)” on page 4-10.

**WARNING**



*To avoid injury, use proper lifting techniques when moving pumps. Your system may have pumps that require two people to move them safely.*

2. Remove the front panel.
3. Remove the right side panel.
4. Disconnect the power plug of the pump from the 947/948/960.  
The plug is located behind the turbo and is best accessed from the right panel.
5. Remove the NW25 clamp from the left manifold.
6. Remove the centering ring and O-ring and place them on a clean surface.
7. Remove the NW25 clamp from the exhaust manifold.
8. Remove the centering ring and O-ring. Place them on a clean surface.
9. Working from beneath the main cabinet, remove the four nuts from the mounting bolts that connect the pump to the bottom of the main cabinet (Figure B-10 on page B-15).

**NOTE**



*You may have to loosen the radiator clamps on the tygon tubing and slide it up the line a bit to give you room to remove the pump.*

10. Remove the pump from the 947/948/960.

### B.4.2.2 Replacing the Dry System Rough Pump

Before you replace the mechanical pump, examine and clean all O-rings centering rings, clamps and the manifold.

#### B.4.2.2.1 Examining and Cleaning Centering Rings, O-rings and Manifold

Refer to “Examining and Cleaning Centering Rings, O-rings and Manifold” on page B-12. Execute steps 1 through 4.

#### B.4.2.2.2 Re-installing the Dry System Rough Pump

##### WARNING



*To avoid injury, use proper lifting techniques when moving pumps. Your system may have pumps that require two people to move them safely.*

To perform this procedure:

1. Ensure the area is clean for the new pump.
2. Place the new pump in the 947/948/960 oriented as shown in Figure B-10 on page B-15, placing the mounting bolts into the holes in the floor of the cabinet.
3. Place the centering ring and O-ring against the pump outlet on the left side of the pump.
4. Place the manifold against the centering ring.
5. If necessary, shift the pump so that the connection is clean and there is no strain on the manifold.
6. Place the NW25 clamp onto the connection and tighten fully.
7. Place the centering ring and O-ring against the right side pump outlet.
8. Place the exhaust manifold against the centering ring.
9. Place the NW16 clamp onto the connection and tighten fully.
10. Working from under the leak detector, place the nuts on the mounting bolts that mount the pump to the cabinet and tighten them fully.
11. Connect the pump power cord into the 947/948/960.

##### CAUTION



*To ensure reliable testing, after servicing any part of the vacuum system, the 947/948/960 must be leak checked again. Refer to “Leak Checking” on page 4-5 for guidelines.*

12. Replace the front panel.
13. Replace the side panel.
14. Reconnect the mains power supply.
15. Turn the leak detector on and wait for the system to be ready.

Allow the pumps to warm up if the detector has been off for some time.



*Allow a new pump to run for one hour and then perform an autocal.*

16. **Models 948/960 only:** Once the system has pumped down, clean and fill the Liquid Nitrogen Cold Trap using the procedure described in “Liquid Nitrogen Cold Trap (Models 948/960 only)” on page 4-10.

Follow all warnings and cautions in the procedure.

17. Calibrate the 947/948/960 using the procedure described in “Re-calibrate the Internal Calibrated Leak” on page 4-7.
18. Leak check the assembly before using the 947/948/960 for testing.

## B.5 Replacing the Forepump

### B.5.1 Wet

This section includes procedures for replacing forepumps in wet systems (“Removing the Wet System Forepump” on page B-23) and forepumps in dry systems (“Removing the Dry System Rough Pump” on page B-20).

In both cases, the forepump is mounted on the bottom of the right side of the main cabinet.

**WARNING**



*To avoid injury, use proper lifting techniques when moving pumps. Your system may have pumps that require two people to move them safely.*

Before replacing the forepump:

- Refer to the appropriate pump operations manual.
- Ensure that the replacement pump is either the same one as you are replacing, or a pump that can be used in its place.

### B.5.1.1 Removing the Wet System Forepump

To perform this procedure:

1. Disconnect the mains power supply and make sure that all pumps are off.

**WARNING**



*Disconnect power from the 947/948/960 before performing any maintenance procedure that requires physically disconnecting any part of the system.*

**CAUTION**



**Models 948/960 only:** Remove, empty, and clean the cold trap whenever power is removed. Refer to “Liquid Nitrogen Cold Trap (Models 948/960 only)” on page 4-10.

**WARNING**



*To avoid injury, use proper lifting techniques when moving pumps. Your system may have pumps that require two people to move them safely.*

2. Remove the front panel.
3. Remove the left side panel.
4. Unplug the power plug of the pump from the 947/948/960.
5. Drain the oil following the instruction included in the pump manual.
6. Remove the NW25 clamp from the left manifold.
7. Remove the centering ring and O-ring, and place all connections where the oil will not contaminate other parts.
8. Loosen the lower radiator clamp holding the tygon tubing around the bottom section of the foreline.
9. Remove the bottom section of the foreline, and place it where oil will not contaminate other parts.
10. Remove the NW16 clamp from the exhaust connection.
11. Remove the exhaust fitting.
12. Remove the centering ring and O-ring, and place all connections where the oil will not contaminate other parts.
13. Working from beneath the main cabinet, remove the four nuts from the mounting bolts that connect the pump to the bottom of the main cabinet (Figure B-10 on page B-15).
14. Remove the pump from the 947/948/960.

### B.5.1.2 Replacing the Wet System Forepump

Before you replace the forepump, examine and clean all O-rings, centering rings, clamps, and manifold.

#### CAUTION



*There may be oil on these parts. Take care not to place them where other parts may be contaminated.*

#### B.5.1.2.1 Examining and Cleaning Centering Rings, O-rings and Manifold

Refer to “Examining and Cleaning Centering Rings, O-rings and Manifold” on page B-12. Execute steps 1 through 4.

#### B.5.1.2.2 Re-installing the Wet System Forepump

#### WARNING



*To avoid injury, use proper lifting techniques when moving pumps. Your system may have pumps that require two people to move them safely.*

To perform this procedure:

1. Ensure the area is clean for the new pump.
2. Place the new pump in the 947/948/960 oriented as shown in Figure B-10 on page B-15, placing the mounting bolts into the mounting holes in the bottom of the cabinet.
3. Place the lower section of the foreline into the tygon hose section to meet the upper foreline section.
4. Place the centering ring and O-ring against the pump outlet on the left side of the pump.
5. Place the lower section of the foreline against the centering ring.
6. If necessary, shift the pump so that the connection is clean and there is no strain on the foreline.
7. Place the NW25 clamp onto the connection and tighten fully.
8. Retighten the radiator clamp around the tygon hose.



9. Place the centering ring and O-ring against the pump outlet on the right side.
10. Place the exhaust fitting against the centering ring.
11. Place the NW16 clamp onto the connection and tighten fully.
12. Working from under the leak detector, place the nuts onto the mounting bolts and tighten them fully.
13. Connect the pump power cord to the 947/948/960.
14. Consult the pump operations manual for any other necessary procedures to be performed before closing the panels or powering up the pump

### CAUTION



*To ensure reliable testing, after servicing any part of the vacuum system, the 947/948/960 must be leak checked again. Refer to "Leak Checking" on page 4-5 for guidelines.*

15. Replace the front panel.
16. Replace the side panel.
17. Reconnect the mains power supply.
18. Turn the leak detector on and wait for the system to be ready.  
Allow the pumps to warm up if the detector has been off for some time.
19. **Models 948/960 only:** Once the system has pumped down, clean and fill the Liquid Nitrogen Cold Trap using the procedure described in "Liquid Nitrogen Cold Trap (Models 948/960 only)" on page 4-10.  
Follow all warnings and cautions in the procedure.
20. Calibrate the 947/948/960 using the procedure described in "Re-calibrate the Internal Calibrated Leak" on page 4-7.
21. Leak check the assembly before using the 947/948/960 for testing.

### B.5.2 Dry System

#### B.5.2.1 Removing the Dry System Forepump

To perform this procedure:

1. Disconnect the mains power supply and make sure that all pumps are off.

**WARNING**



*Disconnect power from the 947/948/960 before performing any maintenance procedure that requires physically disconnecting any part of the system.*

**CAUTION**



**Models 948/960 only:** *Remove, empty, and clean the cold trap whenever power is removed. Refer to “Liquid Nitrogen Cold Trap (Models 948/960 only)” on page 4-10.*

**WARNING**



*To avoid injury, use proper lifting techniques when moving pumps. Your system may have pumps that require two people to move them safely.*

2. Remove the front panel.
3. Remove the right side panel.
4. Disconnect the power plug of the pump from the 947/948/960.  
The plug is located behind the turbo and is best accessed from the right panel.
5. Remove the NW25 clamp from the left manifold.
6. Remove the centering ring and O-ring. Place them on a clean surface.

##### **B.5.2.1.1 Removing the Isolation Valve from the Forepump**

To perform this procedure:

1. Remove the VPI valve.
2. Remove the NW25 clamp from the top of the pump.
3. Disconnect the NW25 clamp at the opposite end of the valve.

### **B.5.2.1.2 Removing the Nitrogen Purge Connection from Pump**



*An electrician or electrical technician is required for proper removal and installation.*

If only maintenance is being performed, the pump can be removed with the valve attached.

To perform this procedure:

1. **Dry System Forepump only:** Remove the forepump.
2. Disconnect AC power.
3. Disconnect the VPI valve at the pump and valve block connector.

### **B.5.2.1.3 Removing the Exhaust Fitting**

To perform this procedure:

1. Remove the NW16 clamp from the exhaust manifold.
2. Remove the centering ring and O-ring, and place them on a clean surface.

### **B.5.2.1.4 Removing the Pump from the Cabinet**

To perform this procedure:

1. Working from beneath the main cabinet, remove the four nuts from the mounting bolts that connect the pump to the bottom of the main cabinet (Figure B-10 on page B-15).



*You may have to loosen the radiator clamps on the tygon tubing and slide it up the line to remove the pump.*

2. Remove the pump from the 947/948/960.

### **B.5.2.2 Replacing the Dry System Forepump**

Before you replace the turbo pump, examine and clean all O-rings centering rings, clamps and the manifold.

#### **B.5.2.2.1 Examining and Cleaning Centering Rings, O-rings and Manifold**

Refer to “Examining and Cleaning Centering Rings, O-rings and Manifold” on page B-12. Execute steps 1 through 4.

### **B.5.2.2.2 Re-installing the Dry System Forepump**

#### **WARNING**



*To avoid injury, use proper lifting techniques when moving pumps. Your system may have pumps that require two people to move them safely.*

To perform this procedure:

1. Ensure the area is clean for the new pump.
2. Place the new pump in the 947/948/960 oriented as shown in Figure B-10 on page B-15, and the mounting bolts into the holes in the floor of the cabinet.
3. Place the centering ring and O-ring against the pump outlet on the left side of the pump.
4. Place the manifold against the centering ring.

If necessary, shift the pump so that the connection is clean and there is no strain on the manifold.

5. Place the NW25 clamp onto the connection and tighten fully.

### **B.5.2.2.3 Connecting the Nitrogen Purge Pump**

To perform this procedure:

1. Replace the VPI valve.
2. Attach the NW25 clamp to the top of the pump.
3. Connect the NW25 clamp at the opposite end of the valve.

### **B.5.2.2.4 Replacing the Isolation Valve**

#### **CAUTION**



*An electrician or electrical technician is required for proper removal and installation.*

To perform this procedure:

1. **Dry System Forepump only:** Replace the forepump.
2. Reconnect AC power.
3. Reconnect the VPI valve at pump and the valve block connector.

### **B.5.2.2.5 Replacing the Exhaust Fitting**

To perform this procedure:

1. Place the centering ring and O-ring against the right side pump outlet.
2. Place the exhaust manifold against the centering ring.
3. Place the NW16 clamp onto the connection and tighten fully.

### **B.5.2.2.6 Completing Mounting the Pump to the Cabinet Floor**

To perform this procedure:

1. Working from under the leak detector, place the nuts on the mounting bolts that mount the pump to the cabinet and tighten them fully.
2. Connect the pump power cord into the 947/948/960.

#### **CAUTION**



*To ensure reliable testing, after servicing any part of the vacuum system, the 947/948/960 must be leak checked again. Refer to "Leak Checking" on page 4-5 for guidelines.*

3. Replace the front panel.
4. Replace the side panel.
5. Reconnect the mains power supply.
6. Turn the leak detector on and wait for the system to be ready.

Allow the pumps to warm up if the detector has been off for some time.

#### **NOTE**



*Allow a new pump to run for one hour and then perform an autocal.*

7. **Models 948/960 only:** Once the system has pumped down, clean and fill the Liquid Nitrogen Cold Trap using the procedure described in "Liquid Nitrogen Cold Trap (Models 948/960 only)" on page 4-10.
8. Calibrate the 947/948/960 using the procedure described in "Re-calibrate the Internal Calibrated Leak" on page 4-7.
9. Leak check the assembly before using the 947/948/960 for testing.

*This page intentionally left blank.*

## Appendix C. Communications Protocol

This appendix defines the technical specifications for the RS-232 protocol to be used with the 947/948/960 Leak Detection System optional rear panel interface.

### C.1 Protocol (RS-232)

The RS-232 ports operate at 9600 baud, 8 bits, no parity, and one stop bit.

All characters transmitted to the leak detector are echoed by the leak detector. Commands, inquiries, and strings of commands and inquiries must be terminated by a carriage return <CR>; the carriage return is echoed as a space character.

The maximum length of the input is 80 characters; if no carriage return has been received before the 80th character, execution of the command string begins anyway. Do not explore this feature.

Words that begin with the ? character are inquiries for the controlling device to determine the current state or value of a leak detector parameter. Words that begin with **PUT** are commands for the controlling device to set the current state or value of a volatile leak detector parameter. Words that begin with **INIT-** are commands for the controlling device to set non-volatile leak detector parameters. Other commands do not require a parameter, do not begin with any special character(s), and simply do what they say they do.

Successful inquiries respond with data as specified in the following tables followed by a space, then: **ok**<CR><LF>. Unsuccessful inquiries respond with the offending inquiry followed by a space, then: **#?**<CR><LF> (line feed, <LF>). Certain commands are restricted from use while PARALLEL ENABLE is active; these commands respond **cant**<CR><LF>.

Inquiries, parameters, and commands can be concatenated. Each word or numeric parameter is followed by one or more spaces. The string is terminated by a <CR>, which causes execution to begin. Successful strings respond with the specified data for the input inquiries in the order the inquiries were issued, followed by: **ok**<CR><LF>. Unsuccessful strings respond with the *first* offending command followed by a space then: **#?**<CR><LF>. All commands and inquiries following the failed word are ignored; all parameters are discarded.

Table C-1 through Table C-4 outline the available control and query commands.

- ❑ Table C-1 lists inquiries used to determine internal operating parameters. All inquiries, except VER, begin with **?** and end with <CR>.
- ❑ Table C-2 on page C-5 lists commands used to set NON-VOLATILE operating parameters.
- ❑ Table C-3 on page C-6 lists commands used to cause an immediate change in the spectrometer operating parameters. These commands do not change the non-volatile operating parameters.
- ❑ Table C-4 on page C-7 lists commands used to cause certain leak detection actions.

**Table C-1 Internal Operating Parameters**

Inquiry	Response
?ALL	Nine lines that report a summary of all ion source parameters. Each line begins with a <CR><LF>. The format is as follows: FILAMENTBIAS 122.1      Reports the filament bias voltage. IONCHAMBER 269.1      Reports the ion chamber voltage. VARIABLEFOCUS 235.4    Reports the variable focus voltage. REPELLER 402.2        Reports the repeller voltage. FIXEDFOCUS 212.7      Reports the fixed focus voltage. SUPPRESSOR 145.0      Reports the suppressor voltage. EMISSIONCURRENT 1.040 Reports the emission current. OFFSET 59              Reports the preamp offset index. GAIN 2.5                Reports the leak rate gain factor.
?AZ<0	A string of three characters that reads either <b>off</b> or <b>on</b> to tell whether AUTOZERO <0 is operating.
?CALOK	One line. <b>yes</b> or <b>no</b> , indicating the success of the last CALIBRATE.
?EMISSIONCURRENT	Reports the emission current. The format is: EMISSIONCURRENT 1.040
?FILAMENTBIAS	Reports the filament bias voltage. The format is: FILAMENTBIAS 122.1
?FIXEDFOCUS	Reports the fixed focus voltage. The format is: FIXEDFOCUS 212.7
?FL-XFER	A string of seven characters that tells the maximum pressure in Torr for transfer from gross leak test to fine leak test (e.g., 1.0E-01).
?GAIN	A three-character number consisting of a two-digit gain factor with a decimal point after the first digit.



Table C-1 Internal Operating Parameters (Continued)

Inquiry	Response
?GL-XFER	A string of seven characters that tells the maximum pressure in Torr for transfer from roughing to gross leak test (e.g., 7.5E-01).
?IONCHAMBER	Reports the ion chamber voltage. The format is: IONCHAMBER 269.1
?LEAK	An eight-character number consisting of a three-digit leak rate mantissa with decimal point after the first digit followed by <b>E-</b> , then a two-digit number, which is the leak rate range exponent (e.g., 1.35E-07).
?nREJECT	A six-character number consisting of a two-digit reject leak rate mantissa with a decimal point after the first digit followed by <b>E-</b> , followed by a two-digit leak rate range exponent (e.g., 7.0E-05). This inquiry reports the value of the requested set point, where <i>n</i> is the reject set point 1 through 4.
?OFFSET	A number representing the position of the preamplifier offset (digi-pot) device as a percent of full scale. 50 represents mid-scale.
?PRESSURES	Two lines. Each line begins with a <CR><LF>. First line                      Consists of the words <b>test port</b> followed by a number of mTorr. Second line                      Consists of the words <b>system TC</b> followed by a number of mTorr.
?RANGESTOP	A string of three characters that tells the most sensitive range exponent when the auto range function is operating.
?REJECT	A nine-character string consisting of a one digit reject number (1,2,3,4), a space, a two-digit reject leak rate mantissa with a decimal point after the first digit, <b>E-</b> , and a two-digit number which is the reject leak rate range exponent (e.g., 7.0E-05).  This inquiry is used for reporting the reject leak rate that was most recently input using one of the INIT- <i>n</i> REJECT commands.
?REPELLER	Reports the repeller voltage. The format is: REPELLER 402.2
?ROUGH	A string of three digits that tells the number of seconds set into the sequencer's rough timer.
?RSONOFF	A string of three characters that reads either <b>off</b> or <b>on</b> to tell whether the Range Stop feature is operating.
?SEQONOFF	A string of three characters that reads either <b>off</b> or <b>on</b> to tell whether the auto sequence function is operating.

Table C-1 Internal Operating Parameters (Continued)

Inquiry	Response
?SETUP	<p>Eight lines that report a summary of setup parameters. Each line begins with a &lt;CR&gt;&lt;LF&gt;. The format is as follows:</p> <p>First line Reports the turbo pump speed as <b>High, Low, or Off</b>.</p> <p>Second line Reports the least sensitive leak rate range, and the ranging method as auto or manual.</p> <p>Third line Reports the selected manual leak rate range.</p> <p>Fourth line Reports the reject number and the reject setpoint leak rate.</p> <p>Fifth line Reports the calibration standard leak rate.</p> <p>Sixth line Reports the analog leak rate output voltage method as Linear, Log(2V), or Log(3V).</p> <p>Seventh line Reports the active filament status as <b>One or Two</b>, followed by <b>Lit or Out</b>.</p> <p>Eighth line Reports the use of internal or external STDLEAK for calibration.</p>
?STDLEAK	<p>A seven-character number consisting of a two-digit calibration standard leak rate mantissa with a decimal point after the first digit, followed by <b>E-</b>, then by a two-digit number which is the calibration standard leak rate range exponent (e.g., 1.3E-07).</p> <p>This inquiry is used for reporting the calibration standard leak rate that was most recently input using INIT-STDLEAK.</p>
?SUPPRESSOR	<p>Reports the suppressor voltage. The format is: SUPPRESSOR 145.0</p>
?TEST	<p>A string of three digits that tells the number of seconds set into the sequencer's test timer.</p>
?TURBO	<p>Three lines. Each line begins with a &lt;CR&gt;&lt;LF&gt;.</p> <p>First line Consists of the words <b>turbo</b> followed by either <b>Ok</b> or <b>Not Ok</b>.</p> <p>Second line Consists of the words <b>turbo</b> followed by either <b>Fault</b> or <b>No Fault</b>.</p> <p>Third line Consists of the words <b>turbo speed</b> followed by <b>Off, Fast, or Slow</b>.</p>
?VARIABLEFOCUS	<p>Reports the variable focus voltage. The format is: VARIABLEFOCUS 235.4</p>
VER	<p>Reports a date in the form <b>30 AUG 2001</b> followed by a six-digit hexadecimal checksum.</p>

## Models 947, 948 and 960 Leak Detectors Operations and Service Manual

Table C-2 lists the commands used to set NON-VOLATILE operating parameters. The current value of the operating parameter is changed to a new value. If parallel enable is asserted, the response is **cant <CR> <LF>**.

**Table C-2 Non-volatile Operating Parameters**

Command	Response
INIT-2LOG	No parameter. The analog leak rate output voltage becomes logarithmic at 2 V per decade.
INIT-3LOG	No parameter. The analog leak rate output voltage becomes logarithmic at 3 V per decade.
INIT-AZ<0	Preceded by a single digit, either 0 to turn AUTOZERO off, or 1 to turn the feature on.
INIT-DAC	Sets a positive offset voltage in millivolts to electrically null the analog output voltage. A number in the range 0 to 255, followed by a space, then INIT-DAC.
INIT-EMISSION	Sets the emission current of the ion source. A four-digit number of microamps, in the range 300 to 2000.
INIT-FILAMENT	Sets the operating filament in the ion source. Enter the number of the desired filament (1 or 2), then a space, then INIT-FILAMENT. For example, entering 1 INIT-FILAMENT<CR> makes Filament #1 in the Ion Source the active filament.
INIT-FL-XFER	Sets the minimum pressure in Torr that must be attained to transfer from gross leak to fine leak test. A seven-character string, two mantissa digits with a decimal point between them, E, and a three-character signed exponent (e.g. 5.0E-02).
INIT-FOCUS	Sets the variable focus voltage of the ion source. A three-digit number of volts, in the range 100 to 250.
INIT-GAIN	Sets the gain used for adjusting the helium signal to match a calibrated standard leak. A two-digit number with a decimal point after the first digit, in the range 1.0 to 9.0.
INIT-GL-XFER	Sets the minimum pressure in Torr that must be attained to transfer from roughing to gross leak test. A seven-character string, two mantissa digits with a decimal point between them, E, and a three-character signed exponent (e.g. 8.0E-01).
INIT-ION	Sets the ion voltage of the ion source. A three-digit number of volts, in the range 150 to 350.
INIT-LINEAR	No parameter. The analog leak rate output voltage assumes the LINEAR mode.
INIT- <i>n</i> REJECT	The helium leak rate number in atm cc/sec. The format is: a two-digit leak rate mantissa with a decimal point after the first digit, followed by E-, and then by a single digit which is the leak rate range exponent.  Use to set the value of reject set point, where <i>n</i> is the set point 1 through 4. Values outside the working range of the leak detector are not stored.

**Table C-2 Non-volatile Operating Parameters (Continued)**

Command	Response
INIT-RANGESTOP	Sets the most sensitive range exponent attainable when the feature is operating. Preceded by a minus sign and one or two digits (e.g., -08).
INIT-REPELLER	Sets the repeller voltage of the ion source. A three-digit number of volts, in the range 200 to 450.
INIT-ROUGH	A one-to-three digit number of seconds of maximum roughing time for auto-sequencer operation.
INIT-SPEED	Sets the operating speed of the high vacuum pump. Enter 0 (for slow) or 1 (for fast), then INIT-SPEED. For example, entering 0 INIT-SPEED<CR> commands the high vacuum pump to run at slow speed.
INIT-STDLEAK	The helium leak rate number in atm cc/sec of the calibrated standard leak. The format is: a two-digit leak rate mantissa with a decimal point after the first digit, E-, and a single digit which is the leak rate range exponent. Values outside the working range of the leak detector are not stored.
INIT-TEST	A one-to-three digit number of seconds of maximum testing time for auto-sequencer operation.

Table C-3 lists the commands used to cause an immediate change in the spectrometer operating parameters. These commands do not change the non-volatile operating parameters.

**Table C-3 Spectrometer Operating Parameters**

Command	Response
PUT-EMISSION	Sets the emission current of the ion source. A four-digit number of microamps, in the range 300 to 2000.
PUT-FOCUS	Sets the variable focus voltage of the ion source. A three-digit number of volts, in the range 100 to 350.
PUT-GAIN	Adjusts the helium signal to match a calibrated standard leak. A two-digit number with a decimal point after the first digit, in the range 1.0 to 9.0.
PUT-ION	Sets the ion voltage of the ion source. A three-digit number of volts, in the range 150 to 350.
PUT-OFFSET	Sets the preamplifier offset index for nulling the preamplifier in the spectrometer tube. A two-digit number, in the range 00 to 99.
PUT-REPELLER	Sets the repeller voltage of the ion source. A three-digit number of volts, in the range 200 to 450.

## Models 947, 948 and 960 Leak Detectors Operations and Service Manual

Table C-4 lists the commands used to cause leak detection actions.

**Table C-4 Command Parameters for Leak Detection Actions**

Command	Action
CALIBRATE	Adjusts the Ion source parameters to cause a maximum response to helium, then adjusts the gain so that the current helium signal is the same as most recently input using INIT-STDLEAK. Success is indicated by a <b>yes</b> response to ?CALOK<CR>. With PARALLEL ENABLE asserted, the response is <b>cant</b> .
DISABLE-RANGESTOP	Causes range limiting to cease operation. No parameters.
DISABLE-SEQUENCER	Causes the auto-sequencer to cease operation. No parameters.
ENABLE-RANGESTOP	Causes range limiting to begin operation. No parameters.
ENABLE-SEQUENCER	Causes the auto-sequencer to begin operation. No parameters.
FPEAK	Adjusts the variable focus Ion Source parameter to cause a maximum response to helium. With PARALLEL ENABLE asserted, the response is <b>cant</b> .
KEEP	Causes the leak detector to close most valves and enter the HOLD state. No parameters.
ROUGH	Causes the leak detector to begin a roughing and testing sequence. No parameters.
SYTCATM	Sets the current system thermocouple reading to represent atmospheric pressure. Success is indicated by the normal <b>ok</b> response.
SYTCZERO	Sets the current system thermocouple reading to represent a pressure that is too low for a thermocouple to read. Success is indicated by the normal <b>ok</b> response.
TPTCATM	Sets the current test port thermocouple reading to represent atmospheric pressure. Success is indicated by the normal <b>ok</b> response.
TPTCZERO	Sets the current test port thermocouple reading to represent a pressure that is too low for a thermocouple to read. Success is indicated by the normal <b>ok</b> response.
TUNE	Adjusts Ion voltage to cause a maximum response to helium. With PARALLEL ENABLE asserted, the response is <b>cant</b> .
VENT	Causes the leak detector to vent the test port to atmosphere. No parameters.
ZERO	Sets the current leak rate measurement to be 0.00 atm cc/sec. Success is indicated by the normal <b>ok</b> response. With the PARALLEL ENABLE asserted, the response is <b>cant</b> .

*This page intentionally left blank.*

## Appendix D. Inputs and Outputs

The Table D-1 through Table D-5 list the signals available on the connector in the turret, and the various connectors of the optional rear panel interface.

### D.1 Service Serial Interface (J1)

The service RS-232 serial interface inside the lockable turret, is used to connect to the Service Pendant. Table D-1 provides details about this connection.

**Table D-1 Service Serial Interface (J1)**

Pin	Signal Name	Description	Input/Output
2	DATA IN	Data to the leak detector from a PC/Service Pendant	Input
3	DATA OUT	Data from the leak detector to a PC/Service Pendant	Output
5	DATA GROUND	Signal Return	System Ground
9	—	Dedicated to Service Pendant. Do not use.	—

### D.2 Optional Rear Panel Interface

This section includes I/O details for the connectors of the optional rear panel interface.

#### D.2.1 Discrete I/O Parallel Interface (J120)

The discrete I/O DB37 connector is used to control operations via a PLC. Table D-2 provides details about this connection.

**Table D-2 Optional Discrete I/O Parallel Interface (J120)**

Pin	Signal Name	Momentary or Level	Description	Input/Output
1, 25	Ground return for J120			
2	Reject Output	Active High	Leak rate signal is higher than the reject set point.	Output
3	Stop	200 msec high pulse	Goes to vent mode.	Input
4	Start	200 msec high pulse	Goes to fine test via rough gross modes.	Input

## Models 947, 948 and 960 Leak Detectors Operations and Service Manual

**Table D-2 Optional Discrete I/O Parallel Interface (J120) (Continued)**

6	Parallel Enable	Active High	Enables rear panel PLC Interface.	Input
7	Zero	200 msec high pulse	Begins Auto Zero routine.	Input
9	Auto Cal	200 msec high pulse	Begins Auto Calibrate.	Input
10	Decrement	200 msec high pulse	Decrements the exponent when in manual ranging.	Input
11	Increment	200 msec high pulse	Increments the exponent when in manual ranging.	Input
12	Auto Range	Active High	Automatically changes the exponent to keep the reading in range.	Input
14	Hold		Not used.	Input
15	Filament Fault	Active High	Active when the selected ion source filament is non-functional.	Output
16	Not Ready	Active High	Not ready to run – possible fault.	Output
18	CAL OK	Active High	Active when last CALIBRATE successful.	Output
19	Zeroing	Active High	Active when Auto Zeroing.	Output
21	Calibrating	Active High	Active when Auto Cal.	Output
23	Ready	Active High	Active when system is operating (inverse of “Not Ready”).	Output
27, 28	+24 VDC for Output Sourcing			Output



**D.2.2 BCD Discrete Output Parallel Interface (J121)**

The discrete I/O DB25 connector is used to control operations via a PLC. Table D-3 provides the J121 DB25 BCD connections.

**Table D-3 Optional BCD Discrete Output Parallel Interface (J121)**

Pin	Signal Name	Momentary or Level	Description	Input/Output
1, 2, 24, 25	Ground for J121			
20,21	+24 VDC for Output Sourcing			
22	Analog Leak Rate	Analog Voltage	0 to 10 V signal that is updated when in running mode	Output
23	Analog Leak Rate	Analog Voltage	Return for pin 22	Output
19	Leak Rate Update Pulse	Output	Leak rate is updated on falling edge and is stable as long as output is low	Output
<b>Mantissa</b>				
3	LSD A	Active High	BCD Leak Rate.	Output
4	LSD B	Active High	BCD Leak Rate.	Output
5	LSD C	Active High	BCD Leak Rate.	Output
6	LSD D	Active High	BCD Leak Rate.	Output
7	MSD A	Active High	BCD Leak Rate.	Output
8	MSD B	Active High	BCD Leak Rate.	Output
9	MSD C	Active High	BCD Leak Rate.	Output
10	MSD D	Active High	BCD Leak Rate.	Output
<b>Exponent</b>				
11	LSD A	Active High	BCD Leak Rate.	Output
12	LSD B	Active High	BCD Leak Rate.	Output
13	LSD C	Active High	BCD Leak Rate.	Output
14	LSD D	Active High	BCD Leak Rate.	Output
15	MSD A	Active High	BCD Leak Rate.	Output
16	MSD B	Active High	BCD Leak Rate.	Output
17	MSD C	Active High	BCD Leak Rate.	Output
18	MSD D	Active High	BCD Leak Rate.	Output

### **D.2.3 Interface (J122) for Optional Universal Remote Control**

The optional Universal Remote Control connects to J122, a DB9 connector. The serial communication cable from the Universal Remote Control is connected to J122 on the back of the 947/948/960. Refer to the Universal Remote Control manual for further information. Table D-4 provides details about this connection.

**Table D-4 Optional Interface (J122) for Optional Universal Remote Control**

<b>Pin</b>	<b>Name</b>	<b>Signal Description</b>	<b>Output</b>	<b>Input/Level</b>
1		Shield	System Ground	
2	DATA IN	Data to the host from a Remote Control	Input	Logic
3	DATA OUT	Data from the host to a Remote Control	Output	Logic
5	+24 VDC RET	24 Volt Return	System Ground	
8	DATA GROUND	Digital Ground	System Ground	
9	+24 VDC	24 VDC supply from the host	Input	

### **D.2.4 Host Serial Port (J123)**

The Host Serial Port connector is used to interface the 947/948/960 to a PLC or computer via an RS-232 DB25 connection. Table D-5 provides details about this connection.

**Table D-5 Optional Host Serial Port RS-232 Interface (J123)**

<b>Pin</b>	<b>Signal Name</b>	<b>Description</b>	<b>Input/Output</b>
1	Shield	Shield for J123	System Ground
2	RXD	Receive Data	Input
3	TXD	Transmit Data	Output
4	CTS	Clear To Send	Input
5	RTS	Ready To Send	Output
6	DTR	Data Terminal Ready	Output
7	Data Ground	Signal Return for J123	
20	DSR	Data Set Ready	Input

# Appendix E. 947/948 Specifications

Table E-1 contains the specifications for Models 947/948/960.

**Table E-1 947/948/960 Specifications**

Platform	947				948/960			
	V70 Turbo Pumping Speed N <sub>2</sub> , 70 l/s		V70D MacroTorr Pumping Speed N <sub>2</sub> , 60 l/s		V70 Turbo Pumping Speed N <sub>2</sub> , 70 l/s		V70D MacroTorr Pumping Speed N <sub>2</sub> , 60 l/s	
Rough Pump/Forepump	Wet (Oil-based)		Wet (Oil-based)		Wet (Oil-based)		Wet (Oil-based)	
	Rough Pump Type: Free Air Displacement	DS-202	DS-302	DS-202	DS-302	DS-202	DS-302	DS-202
195/170		310/250	195/170	310/250	195/170	310/250	195/170	310/250
Forepump Type: Free Air Displacement l/m, 60/50 Hz	DS-202	DS-202	DS-202	DS-202	DS-202	DS-202	DS-202	DS-202
	195/170	300/250	195/170	300/250	195/170	300/250	195/170	300/250
Vacuum System Arrangement	Contra Flow™				Contra-Flow™ with Cold Trap			
Cold Trap Capacity	N/A				Liquid nitrogen hold for 14 hours after vacuum system cool down.			
Helium Sensitivity, atm cc/sec	2 x 10 <sup>-10</sup>		2 x 10 <sup>-9</sup>		2 x 10 <sup>-10</sup>		2 x 10 <sup>-9</sup>	
Response Time	Less than two seconds for helium, in accordance with AVS Standard 2.1.							
Amplifier Drift	Less than 2% of full scale of the most sensitive range, in accordance with AVS Standard 2.1.							
Noise level	Less than 2% of full scale, peak to peak, in accordance with AVS Standard 2.1.							
Calibration	Fully automatic tuning and calibration routine using the standard calibrated leak or optional external leak. A gross leak is manually calibrated.							
Leak Indication	A 50-segment bar graph indicator displays leak rates automatically, atm cc/sec: from 10 to 2 x 10 <sup>-10</sup> .							
Spectrometer Tube	The manual mode can also be used for any decade scale. A leak can also trigger an audible alarm frequency that varies in proportion to the size of the leak. The preamplifier is computer optimized, temperature stabilized, and solid state. Programmed warm-up minimizes start-up time to 30 minutes. The tube is kept at a constant temperature at all times to maintain stability. The ion-source has dual filaments of long life, thorium-coated iridium.							

Table E-1 947/948/960 Specifications (Continued)

Platform	947		948/960	
	V70 Turbo Pumping Speed N <sub>2</sub> , 70 l/s	V70D MacroTorr Pumping Speed N <sub>2</sub> , 60 l/s	V70 Turbo Pumping Speed N <sub>2</sub> , 70 l/s	V70D MacroTorr Pumping Speed N <sub>2</sub> , 60 l/s
High Vacuum Pump Type: Air-cooled, Maintenance-Free				
Automatic Valve Sequencing	Microprocessor-controlled valve operation provides automatic system cycling. The test and roughing valves are vacuum-activated, requiring no air supply. Automatic shutdown is achieved with a single switch function.			
Safety Interlocks	The valve system design completely protects the high-vacuum system under test against pressure surges and power interruptions.			
Cycle Time	Blanked port can be cycled to the fine leak test in four seconds. The auto sequencer feature provides clear accept/reject signals and allows programming of roughing, testing, and cycling duration.			
Test Port	1-1/8" (28 mm) ID quick coupling type. KF25 (ISO NW-25) adapter included.			
Remote I/O Capabilities	Parallel Interface (DB-25S & DC-37S) with opto-isolated (5 - 24 V) input, Serial RS-232 Interface (DB-25S), Remote Control Interface (DE-09S).			
Accessory (optional)	Remote Control and display unit with 25" cord, service pendant, atmospheric gross leak, external calibrated helium Leaks.			
Recommended Ambient Operating Conditions	Indoor use. Altitude: up to 2000 m, Temperature: 10 °C to 38 °C (50 °F to 100 °F). Maximum relative humidity (HR) 80% for temperatures up to 31 °C (87.8 °F) decreasing linearly to 50% HR at 40 °C. No hoarfrost, dew, percolating water, rain, solar irradiation, etc. Atmospheric air pressure: 75 kPa to 106 kPa. Pollution Degree II, Installation (Overvoltage) Category II in accordance with UL3101-1 Standard.			
Ambient Storage Conditions	Relative humidity: 0% to 95%, non-condensing, Temperature; -34 °C to 65 °C (-30 °F to 150 °F)			
Power Requirements	115 VAC, 20 A, 60/50 Hz or 230 VAC, 10 A, 60/50 Hz. NOTE: Input voltage setup cannot be modified by a customer.			
Conformance Standards	Meets applicable UL, CSA and CE Standards.			
Dimensions	22" W x 33" D x 45" H (559 cm x 818 cm x 1138 cm).			
Shipping Weight	Approximately 510 lb (232 kg).			

Table E-2 contains the 947/948/960 model types and part numbers.

**Table E-2 947/948/960 Model Types and Part Numbers**

Vacuum System Pump Types							
Mains Supply 50/60 Hz	115 VAC	230 VAC	High Vacuum	Low Vacuum	Rough	Fore	
	Model P/N	Model P/N	Turbo	MacroTorr			
<b>947 Contra-Flow™ LD</b>							
947 Turbo LD	L94720200T120	L94720200T220	V70		DS-202	DS-202	
947 Turbo LD	L94720300T120	L94720300T220	V70		DS-302	DS-202	
947 Turbo LD	L94720450T120	L94720450T220	V70		DS-402	DS-202	
947 MacroTorr LD	L94720200M120	L94720200M220		V70D	DS-202	DS-202	
947 MacroTorr LD	L94720300M120	L94720300M220		V70D	DS-302	DS-202	
947 MacroTorr LD	L94720450M120	L94720450M220		V70D	DS-402	DS-202	
947D Turbo Dry LD	D94735350T120	D94735350T220	V70		TriScroll™ 300	TriScroll™ 300	
947D Turbo Dry LD	D94735550T120	D94735550T220	V70		TriScroll™ 600	TriScroll™ 300	
947D MacroTorr Dry LD	D94735350M120	D94735350M220		V70D	TriScroll™ 300	TriScroll™ 300	
947D MacroTorr Dry LD	D94735550M120	D94735550M220		V70D	TriScroll™ 600	TriScroll™ 300	
<b>948 Contra-Flow™ LD with Cold Trap</b>							
948 TURBO LD	L94820200T120	L94820200T220	V70		DS-202	DS-202	
948 TURBO LD	L94820300T120	L94820300T220	V70		DS-302	DS-202	
948 TURBO LD	L94820450T120	L94820450T220	V70		DS-402	DS-202	
948 MacroTorr LD	L94820200M120	L94820200M220		V70D	DS-202	DS-202	
948 MacroTorr LD	L94820300M120	L94820300M220		V70D	DS-302	DS-202	
948 MacroTorr LD	L94820450M120	L94820450M220		V70D	DS-402	DS-202	



Table E-3 947/948/960 Specifications (Continued)

Plattform	947				948/960			
<b>Hochvakuumpumpe Typ: luftgekühlt, wartungsfrei</b>	<b>V70 Turbo Pumpleistung N<sub>2</sub>, 70 l/s</b>		<b>V70D Macro Torr Pump leistung N<sub>2</sub>, 60 l/s</b>		<b>V70 Turbo Pumpleistung N<sub>2</sub>, 70 l/s</b>		<b>V70D MacroTorr Pumpleistung N<sub>2</sub>, 60 l/s</b>	
Vorvakuumpumpe, Typ: Freie Luftverdrängung l/m, 60/60 Hz	DS-202	DS-202	TriScroll™	DS-202	TriScroll™	DS-202	DS-202	DS-202
	195/170	300/250	300/250	195/170	300/250	195/170	195/170	DS-202
Vakuumsystem-Anordnung	Contra Flow™				Contra-Flow™ mit Kühlfalle			
Kapazität der Kühlfalle	nicht zutreffend				Flüssigstickstoff reicht 14 Stunden nach Abkühlung des Vakuumsystems.			
Heliumempfindlichkeit, atm cc/Sek.	2 x 10 <sup>-10</sup>		2 x 10 <sup>-9</sup>		2 x 10 <sup>-10</sup>		2 x 10 <sup>-9</sup>	
Reaktionszeit	Weniger als zwei Sekunden bei Helium, gemäß AVS Standard 2.1.							
Verstärker-Drift	Weniger als 2% des vollen Umfangs des empfindlichsten Bereichs, gemäß AVS Standard 2.1.							
Lärmpegel	Weniger als 2% des vollen Umfangs, Spitze zu Spitze, gemäß AVS Standard 2.1.							
Kalibrierung	Vollautomatisches Einstell- und Kalibrierungsprogramm unter Verwendung des standardgemäßen, kalibrierten Lecks oder des optionalen, externen Lecks. Ein Grobleck wird manuelle kalibriert.							
Leckanzeige	Ein Balkendiagramm mit 50 Unterteilungen zeigt die Leckraten automatisch an, atm cc/Sek.: von 10 bis 2 x 10 <sup>-10</sup> .							
Spektrometerrohr	Der Vorverstärker ist rechneroptimiert, temperaturstabil und ein Festkörper-Vorverstärker. Programmierter Warmlauf verringert die erforderliche Zeit zur Inbetriebnahme auf 30 Minuten. Die Temperatur des Rohrs bleibt durchgehend konstant, um die Stabilität fortwährend zu wahren. Die Ionenquelle verfügt über doppelte Glühfäden aus haltbarem, thoria-beschichtetem Iridium.							
Automatische Ventilfolge	Mikroprozessor-gesteuerte Ventilbetätigung gewährleistet automatischen Systemzyklus. Die Prüf- und Grobvakuumventile sind vakuumaktiviert und erfordern keine Luftzufuhr. Automatisches Abschalten erfolgt über einfache Schalterfunktion.							
Sicherheitssperren	Das Ventilsystem ist so konzipiert, dass es das zu prüfende Hochvakuumsystem vollkommen vor Druckstößen und Stromausfällen schützt.							
Zyklusdauer	Blindport kann in vier Sekunden zur Feinleckprüfung gebracht werden. Die automatische Ablaufsteuerung generiert deutliche Annahme-/Rückweisungssignale und ermöglicht die Programmierung von Grob-, Prüf- und Zykluszeiten.							
Prüfausgang	28 mm ID Schnellkupplungen, KF25 (ISO NW-25) Adapter inbegriffen.							
Kapazitäten der entfernten E/A	Parallele Schnittstelle (DB-25S & DC-37S) mit opto-isolierstem (5 - 24 V) Eingang, serielle RS-232 Schnittstelle (DB-25S), ferngesteuerte Schnittstelle (DE-09S).							
Zubehör (optional)	Fernsteuerung und Anzeigeeinheit mit 63cm Kabel, Hängebedienungsstafel, atmosphärisches Grobleck, extern kalibrierte Heliumlecks.							

Table E-3 947/948/960 Specifications (Continued)

Plattform	947		948/960	
	Hochvakuumpumpe Typ: luftgekühlt, wartungsfrei	V70 Turbo Pumpleistung N <sub>2</sub> , 70 l/s	V70D MacroTorr Pump leistung N <sub>2</sub> , 60 l/s	V70 Turbo Pumpleistung N <sub>2</sub> , 70 l/s
Empfohlene Betriebsbedingungen	Gebrauch in Gebäuden. Einsatzhöhe: bis zu 2000 m, Temperatur: 10 °C bis 38 °C. Maximale relative Feuchtigkeit (HR) 80% für Temperaturen bis zu 31 °C, abnehmende Linearität auf 50% HR bei 40 °C. Kein Rauhreif, Tau, Tropfwasser, Regen, keine Sonnenstrahlen, etc. Atmosphärischer Druck: 75 kPa bis 106 kPa.			
Raumbedingungen bei Aufbewahrung	Verschmutzungsgrad II, Installation (Überspannung) Kategorie II gemäß UL3101-1 Standard.			
Stromanforderungen	Relative Feuchtigkeit: 0% bis 95%, ohne Kondensation, Temperatur: -34 °C bis 65 °C			
Übereinstimmung mit Normen	115 VAC, 20 A, 60/50 Hz oder 230 VAC, 10 A, 60/50 Hz. HINWEIS: Eingangsstrom-Einrichtung kann vom Kunden nicht modifiziert werden.			
Abmessungen	Erfüllt die jeweiligen UL, CSA und CE Normen.			
Versandgewicht	559 cm B x 818 cm T x 1138 cm H. Ca. 232 kg.			

Table E-4 enthält die Modelltypen und Teilnummern für 947/948/960.

Table E-4 947/948/960 Model Types and Part Numbers

Netzstromversorgung 50/60 Hz	Vakuumsystemspumpen					
	115 VAC	230 VAC	Hohes Vakuum	Niedriges Vakuum	Grob	Vor
	Modell Teil-Nr.	Modell Teil-Nr.	Turbo	MacroTorr		
<b>947 Contra-Flow™ LD</b>						
947 Turbo LD	L94720200T120	L94720200T220	V70		DS-202	DS-202
947 Turbo LD	L94720300T120	L94720300T220	V70		DS-302	DS-202
947 Turbo LD	L94720450T120	L94720450T220	V70		DS-402	DS-202
947 MacroTorr LD	L94720200M120	L94720200M220		V70D	DS-202	DS-202



Table E-4 947/948/960 Model Types and Part Numbers (Continued)

Vakuumsystemspumpen							
Netzstromversorgung 50/60 Hz	115 VAC	230 VAC	Hohes Vakuum	Niedriges Vakuum	Grob	Vor	
	Modell Teil-Nr.	Modell Teil-Nr.	Turbo	MacroTorr			
947 MacroTorr LD	L94720300M120	L94720300M220		V70D	DS-302	DS-202	
947 MacroTorr LD	L94720450M120	L94720450M220		V70D	DS-402	DS-202	
947D Turbo Dry LD	D94735350T120	D94735350T220	V70		TriScroll™ 300	TriScroll™ 300	
947D Turbo Dry LD	D94735550T120	D94735550T220	V70		TriScroll™ 600	TriScroll™ 300	
947D MacroTorr Dry LD	D94735350M120	D94735350M220		V70D	TriScroll™ 300	TriScroll™ 300	
947D MacroTorr Dry LD	D94735550M120	D94735550M220		V70D	TriScroll™ 600	TriScroll™ 300	
<b>948 Contra-Flow™ LD mit Kühlfalle</b>							
948 TURBO LD	L94820200T120	L94820200T220	V70		DS-202	DS-202	
948 TURBO LD	L94820300T120	L94820300T220	V70		DS-302	DS-202	
948 TURBO LD	L94820450T120	L94820450T220	V70		DS-402	DS-202	
948 MacroTorr LD	L94820200M120	L94820200M220		V70D	DS-202	DS-202	
948 MacroTorr LD	L94820300M120	L94820300M220		V70D	DS-302	DS-202	
948 MacroTorr LD	L94820450M120	L94820450M220		V70D	DS-402	DS-202	
<b>960 mit Kühlfalle</b>	L96020200T120	L96020200T220	V70		SD-201		
	L96009200T120	L96009200T220	V70		SD-201	SD-91	
	L96009300T120	L96009300T220	V70		SD-301	SD-91	

Table E-4 947/948/960 Model Types and Part Numbers (Continued)

Vakuumsystempumpen						
Netzstromversorgung 50/60 Hz	115 VAC	230 VAC	Hohes Vakuum	Niedriges Vakuum	Grob	Vor
	Modell Teil-Nr.	Modell Teil-Nr.	Turbo	MacroTorr		
	D96035350T120	D96035350T220	V70		TriScroll 300	TriScroll 300 und V70D
	D96035550T120	D96035550T220	V70		TriScroll 600	TriScroll 600 und V70D

## Appendix F. Accessories

The accessories listed below can be purchased separately for use with the 947/948/960. Call Varian Vacuum Technologies for further information at 1-800-8VARIAN.

**Table F-1 947/948/960 Accessories**

<b>Part Number</b>	<b>Option</b>
L9558301	Universal remote control/display unit with 25 ft. cord (requires L9596301)
L9596301	Serial and parallel I/O* includes interface for universal remote control/display unit (platform series)
L6839301	Atmospheric gross leak accessory*

\* Factory installed option

*This page intentionally left blank.*

## Appendix G. Leak Detection Theory

### G.1 Leak Testing—Why is it Needed?

Even with today's complex technology it is, for all practical purposes, impossible to manufacture a sealed enclosure or system that can be guaranteed leak proof without first being tested.

Using the modern mass spectrometer leak testing techniques implemented by the Varian Vacuum Technologies 947/948/960 Helium Leak Detectors, leak rates in the  $10^{-10}$  atm cc/sec range can be reliably detected. The discussion that follows is a summary of information pertinent to the subject of leak detection.

### G.2 Classes of Leak Detection

There are four general classes of leak detection:

<b>Hermetic Enclosures</b> (or parts thereof)	These are tested to prevent entrance of contaminants or loss of fluid that would affect performance of the enclosed unit. Examples include: electronic devices, integrated circuits, sealed relays, motors, ring pull tab can ends, and multi-pin feedthroughs.
<b>Hermetic Systems</b>	These are tested to prevent loss of fluid or gas within. Examples include: hydraulic systems and refrigeration systems.
<b>Evacuated Enclosures</b> (or parts thereof)	These are tested to prevent excessively rapid deterioration of a vacuum over time. Examples include: TV picture tubes, bellows sensing elements, and full-panel opening can ends.
<b>Vacuum Systems</b>	These are tested to minimize inleakage and allow attainment of better vacuum or higher gas removal ability at any given vacuum (absolute pressure).

### G.3 Terminology

The following terminology has application throughout this manual:

**Flow**

atm cc/sec                      One cubic centimeter of gas per second at a pressure differential of one standard atmosphere (760 Torr at 0 °C).

std cc/sec                      One cubic centimeter of gas per second at ambient atmospheric pressure and temperature (used interchangeably with *atm cc/sec* because the difference is insignificant for leak testing purposes).

**Rate-of-Rise**

In vacuum systems this is defined as the rate of increase of absolute pressure per unit time, with the vacuum pump isolated from the system, and is the sum of actual inleakage and internal outgassing. Rate of rise is usually expressed in Torr or microns (milliTorr) per hour. The flow rate should be expressed in Torr-liters/second.

**Conversions**

1 std cc/sec\* 0.76 Torr-liter/sec

1 Torr-liter sec\* 1.3 std cc/sec

1 std cc/sec  $9.7 \times 10^4$  micron cubic feet per hour or practically  $10^5$  micron CFH ( $\mu$ CFH)

1  $\mu$ CFH practically  $10^{-5}$  std cc/sec

*\*for practical purposes, equal*

**Numerical Notation-Exponential System**

Most leak rates of commercial significance are very small fractions of atm cc/sec. Therefore negative powers of ten are used as a convenient system of numerical shorthand.

Table G-1 shows the relationship of exponents and multipliers (to the base 10) to the arithmetic form, and the equivalent result.

**Table G-1 Decimal Notation**

Multiplier x 10 <sup>n</sup>		Arithmetic Form		Result
1 x 10 <sup>2</sup>	=	1 x 10 x 10	=	100
1 x 10 <sup>1</sup>	=	1 x 10	=	10
1 x 10 <sup>0</sup>	=	1	=	1
1 x 10 <sup>-1</sup>	=	1 x 1/10	=	.1
1 x 10 <sup>-2</sup>	=	1 x 1/10 x 1/10	=	.01
5 x 10 <sup>-3</sup>	=	5 x 1/10 x 1/10 x 1/10	=	.005
5 x 10 <sup>-7</sup>	=	5 x 1/10 x 1/10 x 1/10 x 1/10 x 1/10 x 1/10 x 1/10	=	.0000005
5 x 10 <sup>-9</sup>	=	5 x 1/10 x 1/10 x 1/10 x 1/10 x 1/10 x 1/10 x 1/10 x 1/10 x 1/10	=	.000000005

## G.4 Various Methods of Testing for Leaks

There are many methods of testing for leaks in enclosures, systems or containers. The more commonly used methods and their accuracy ranges are listed below:

<b>Water Immersion</b> (Air Bubble Observation)	This method is good to approximately $10^{-3}$ atm cc/sec, and can be more sensitive if internal pressure is increased or vacuum is created above water pressure. This method is limited because of difficulty in differentiating between leakage bubbles and surface desorption bubbles. It is used to test industrial items such as valves, hydraulic components, castings, automotive and air conditioning components.
<b>Dye Penetrant</b>	A special dye, applied to one side of a surface suspected to contain a leak, seeps through the leak and appears on the other side. This method can take an hour or more for a $10^{-4}$ atm cc/sec leak to show up. This test is inexpensive but destructive in some applications, as well as slow and messy.
<b>Ultrasonic</b>	This method is good to approximately $10^{-3}$ atm cc/sec. It tests for ultrasonic sounds coming from a gas leak and for testing high pressure lines.
<b>Halogen</b> (sensitive to halogen elements or compounds, especially refrigerant gases)	This method is good to approximately $10^{-5}$ atm cc/sec in most current applications, but extendable to $10^{-9}$ std cc/sec under some limited situations. It is critically dependent on operator judgement if leaks are below $10^{-5}$ atm cc/sec and requires constant flow of fresh air in the test area because of the tendency of trace gas to <i>hang</i> in the area. The detector used in this method is sensitive to a variety of gases from external sources such as cigarette smoke and solvent fumes.
<b>Radioisotope</b>	This method is useful only for testing hermetically sealed cavities. It has approximately the same range as the helium method but it involves an expensive installation (from four to ten times the cost of a helium installation depending on the degree of isolation of radiation required). It also requires a radiation safety officer.
<b>Helium</b>	This method is good to $10^{-11}$ atm cc/sec, and is capable of finding leaks of any size larger. It is useful for testing hermetic seals, vacuum enclosures, and vacuum systems, and is the most versatile of industrial and laboratory leak detection testing methods.

## G.5 Helium Mass Spectrometer Leak Detection (MSLD)

Helium is an excellent trace gas because it is the lightest of the inert gases and as a consequence readily penetrates small leaks. In addition, its presence in the atmosphere is minute (5 PPM or 4 milliTorr absolute). Helium is easily detected by a simple mass spectrometer (helium has a mass of 4 so that adjacent *peaks* of 3 and 6 are easily separated by this technique). Also, helium is readily available at reasonable cost, and is completely non-toxic and non-reactive. The basic principles of the helium MSLD technique are discussed below.

### G.5.1 Principles of Mass Spectrometry

A mass spectrometer sorts gases by their molecular weights (mass number) to determine the quantity of each gas present. With the helium MSLD, the point of interest is primarily in helium and the mass spectrometer tube is relatively simple. The principle is to ionize the gases in vacuum, accelerate the various ions through a fixed voltage, and then separate the ions by passing them through a magnetic field. A slit, properly placed, allows only helium ions to pass through and be collected. The resulting current is amplified and a leak rate bar graph indicates the presence and amount of helium.

### G.5.2 Application as a Leak Detector

A mass spectrometer leak detector consists of a spectrometer tube, the electronics to operate and interpret it, and a high vacuum system to maintain proper vacuum. In addition, means are provided for connecting a test object, and a *rough vacuum* pump and a system of *roughing* and *test* valves is provided to evacuate the test object for connection to the spectrometer tube; or, if it is a sealed object containing helium, to evacuate a chamber containing the test object.

### G.5.3 The Nature of Flow in a Vacuum

It should be noted that the purpose of the vacuum system is to support operation of the analyzing spectrometer tube. Helium molecules entering through a leak individually reach the spectrometer tube in a few milliseconds. Helium molecules as well as molecules of other gases are continuously removed by the vacuum system turbo pump. If helium is continuously applied to a leak, the concentration in the spectrometer tube rises sharply at first, then reaches equilibrium when it is being pumped out at the same rate as it is entering. When helium is completely removed from the leak, the input drops to zero while the residual helium is pumped out of the system. Thus, a leak is indicated by a rise in output signal of the spectrometer tube.

### G.5.4 Facts About Leak Rates

#### Visualizing Leaks in Everyday Terms

$10^{-5}$  atm cc/sec: approximately 1 cc/day

$10^{-7}$  atm cc/sec: approximately 3 cc/year



### Audible or Visual Detection by Observer

a. Bubbles rising in water  $10^{-4}$  atm cc/sec or larger

b. Audible Leaks  $10^{-1}$  atm cc/sec or larger

### Sizes of Leaks in Man-Made Joints

Studies indicate that almost all leaks at joints are about  $5 \times 10^{-7}$  std cc/sec (about 1 cc/month) or larger. This is true of ceramic-to-metal, plastic-to-metal seals, welded, soldered and brazed joints. Some long-path leaks are slightly smaller. Diffusion of helium through glass can be as high as  $10^{-8}$  std cc/sec per square centimeter of surface area.

### Variation in Leak Sizes

Leaks unintentionally *built-in* at joints during manufacture can vary from hour to hour and day to day. Breathing on a  $10^{-6}$  std cc/sec leak provides enough moisture to close it temporarily; perhaps for several days. Atmospheric particles can close a leak of this size. Never depend on an *accidentally made* leak to remain constant. Manufactured standard leaks for calibration purposes require special techniques.

## G.6 Leak Detection Methods

Most leak detection methods depend on the use of a tracer gas passing through the leak and being detected on the other side (for example, visual detection of air bubbles in water).

The mass spectrometer leak detector operates with helium as a tracer and is widely used because it combines high sensitivity with production testing capability. There are three basic methods in common use.

### G.6.1 Test Piece Evacuated

The object to be tested is evacuated by the leak detector roughing pump, then valved into the spectrometer vacuum system (see Figure G-1 and Figure G-2). The surface of the test object is then probed with a small jet of helium to locate individual leaks, or surrounded by helium (hooded) for an overall leak check.

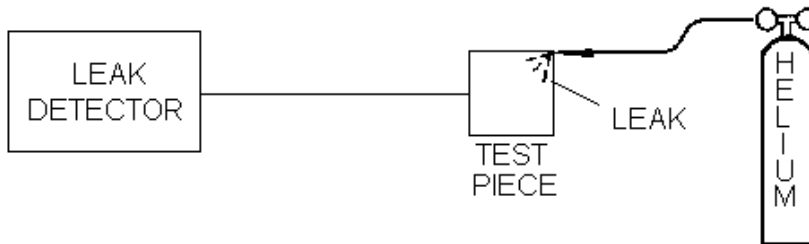

**Figure G-1 Test Piece Evacuated: Tracer Probe Used to Locate Leak**

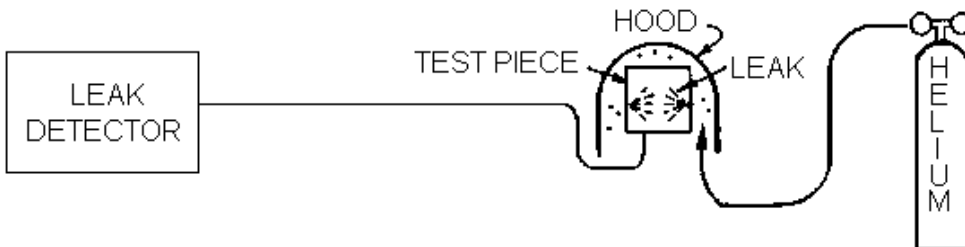

**Figure G-2 Test Piece Evacuated and Hooded with Helium Atmosphere to Determine Overall Leak Rate**

### G.6.2 Test Piece Pressurized

Figure G-3 is an illustration of a Detector Probe used to locate a leak in a pressurized test piece.

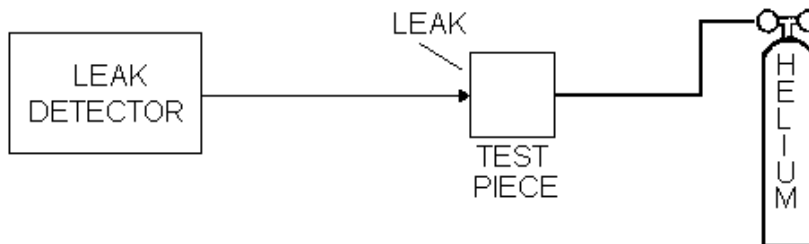

**Figure G-3 Test Piece Pressurized: Detector Probe Used to Locate Leak**

A sampling probe is connected to the leak detector. The object to be tested is filled with helium at the desired test pressure and the probe is moved over its surface. Some of the helium escaping from a leak is captured through the probe and enters the leak detector, thus locating the leak.

Sensitivity of this type of testing is limited to about  $10^{-7}$  atm cc/sec, since most of the escaping helium diffuses into the surrounding atmosphere. The sensitivity is also limited by operator technique and variation in ambient helium concentration in the vicinity of the testing.

An alternative to probing is to enclose the object and probe the enclosure for a change in helium content.

### G.6.3 Test Piece Already Sealed

Figure G-4 is an illustration of a bell jar used to determine overall leak rate of a sealed test piece.

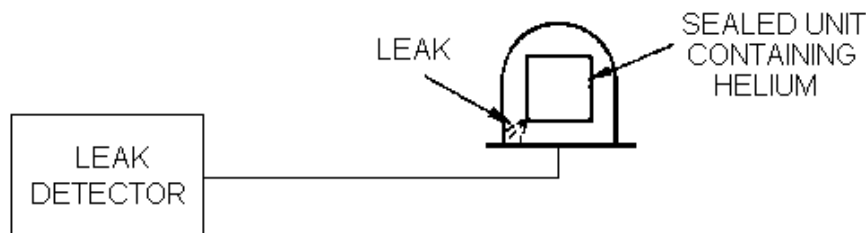

**Figure G-4 Test Piece Sealed with Helium and/or Other Gases – Bell Jar Used to Determine Overall Leak Rate**

Sometimes it is necessary to leak check a completely sealed object. This can be done by placing helium inside the object (either 100% or mixed with other gas used for backfilling) before sealing it. The object is then placed in a vacuum chamber connected to the leak detector. Helium escaping from the object into the vacuum chamber is detected by the spectrometer tube. Sensitivity depends on the partial pressure of helium in the object.

If the presence of helium in the finished object is undesirable, units already sealed can first be placed in a container that is then pressurized with helium for a specific time at a known pressure. Helium enters the object through leaks that are later detected, as described in the previous paragraph. Gross leaks are sometimes not detected, since all the helium entering through a large leak can be lost prior to testing. Also, spurious signals can be given by helium not entering the object, but entering surface fissures and remaining long enough to be detected.

## G.7 Mass Spectrometer Leak Detector—Simplified Description

The 947/948/960 consist of an analytical sensing tube called a *spectrometer tube*, electronics to operate the tube, and a vacuum system to maintain a very high vacuum within this tube (usually less than 0.1 milli Torr or about one ten-millionth of ordinary atmospheric pressure).

In the spectrometer tube, gas molecules are ionized (given a positive electrical charge) by bombarding them with electrons from a hot thoriated iridium filament. The ions, thus formed, are accelerated into a magnetic field where the mass 4 (helium) ions are deflected 90° (see Figure G-5). Only helium ions reach the collector.

An extremely stable electrometer provides an electron current to the collector, which neutralizes the current produced by the collection of helium ions. The *feedback* current is presented on the leak rate bar graph. Since this current is directly proportional to the number of helium ions striking the collector per unit time, the panel leak rate bar graph directly reflects the concentration of helium in the vacuum system at any time. Any helium entering the system causes an increased concentration of helium within the spectrometer tube, which is reflected as an increase on the leak rate bar graph. In addition to the electrometer, the electronics also provide suitable voltages to operate the spectrometer tube and controls and instrumentation for the vacuum system.

Test pieces are generally *rough* pumped (or, if pressurized, the chamber in which they are to be tested is *rough* pumped) by a mechanical vacuum pump before they are connected to the spectrometer tube (see Figure G-5). This prevents overloading the vacuum pumping system.

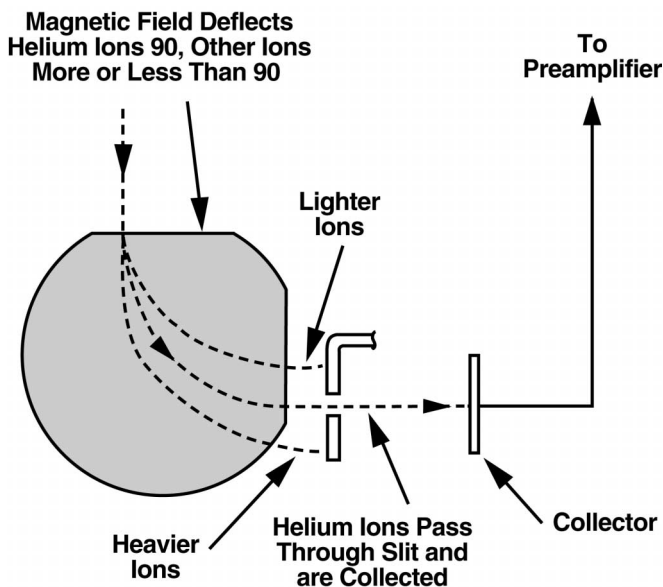

Figure G-5 Magnetic Separation Principle

# Index

## A

- Accessories available F-1
- Air filter replacement 4-21
- atm vs. std G-2
- Atmospheric calibration 4-28
  - System pressure gauge 4-28
  - Test port 4-31
- Audio volume control 3-5
- Auto cal routine indicator 3-2
- Auto ranging 3-13
- Auto-sequencer 3-5
- Auto-zero sequence indicator 3-2

## B

- Bar graph display
  - Linear 3-5
  - Logarithmic 3-5
- BCD discrete I/O parallel interface (option) D-3
- BCD J121 outputs 2-6

## C

- Calculating leak rate G-6
- Calibration checks 3-12
- Circuit breakers
  - Rear panel 1-9
- Cold trap
  - Liquid nitrogen amount 1-12
  - Refilling 3-10
- Command parameters C-7
- Communications protocol B-1, C-1
- Connections
  - Circuit breakers 1-9
  - Discrete I/O (option) 2-9, 3-16
  - Interface, optional 1-13
  - Optional interface ports 2-8
  - Power 1-9
- Controls
  - Front panel 1-6
- Conversions, definition of G-2

## D

- Daily maintenance 4-5
- Decimal notation table G-2
- Diagnostics using the service pendant 3-16
- Discrete I/O (option) 2-9, 3-16

- J120 inputs 2-5
- Parallel enable 2-11
- Parallel interface D-1
- Dual mechanical pump configuration
  - Gross test only 3-7

## E

- Electronic communications (option)
  - BCD J121 outputs 2-6
  - Discrete I/O J120 inputs 2-5
  - Host serial port J123 pinouts 2-7
- Electronic interface, optional 2-5
- Error condition codes 5-2
- Evacuated enclosures G-1
- Exchange
  - Reinstalling the spectrometer tube 4-22
  - Spectrometer tube 4-22

## F

- Fine test (normal) mode 3-7
- Flow diagram
  - 947 2-2
  - 948 2-4
- Flow, definition of G-2
- Forepump oil level check 1-12, 4-32
- Front panel
  - Auto/Man mode switch 1-7
  - Detector power switch 1-6
  - Display button 1-6
  - Leak rate exponent display 1-7
  - Leak rate mantissa bar graph 1-7
  - LED controls 1-7, 3-1
  - Rough pump power switch 1-6
  - Start button 1-7
  - Volume control 1-6

## G

- Gauge calibration 4-27
  - Atmospheric 4-28
  - System pressure 4-28
  - Test port pressure 4-29
  - Vacuum (low pressure) 4-28
- Gross leak xfer 3-7
- Gross test only mode 3-7
- Grounding 2-8

## H

- Hazard and safety information 1-iv
- Helium for sealing G-7
- Helium mass spectrometer leak detection G-4
- Hermetic
  - Enclosures G-1
  - Systems G-1
- Hold mode indicator 3-2
- Host serial port interface (option) D-4
- Host serial port J123 pinouts 2-7

## I

- Installation
  - Liquid nitrogen 1-12
  - Power supply 1-11
  - Services 1-12
  - Special requirements 1-12
  - Vacuum pumps 1-12
- Instruction label 1-8
- Interface
  - Service serial signal D-1
- Interface, optional
  - BCD discrete I/O parallel signal D-3
  - BCD J121 outputs 2-6
  - Connections 2-8
  - Discrete I/O 2-9
  - Discrete I/O J120 inputs 2-5
  - Discrete I/O parallel signal D-1
  - Grounding 2-8
  - Host serial port J123 pinouts 2-7
  - Host serial port signal D-4
  - PLC 2-5, 2-7
  - Rear panel connections 1-13, 2-8
  - Setup 2-9
  - Universal remote control (option) signal D-4
- Internal operating parameters C-2

## L

- Leak checking 4-6
- Leak detection methods G-5
  - Already sealed G-7
  - Evacuated G-6
  - Pressurized G-6
- Leak detector maintenance 4-1
- Leak detector storage 1-13
- Leak rate 3-5, G-5, G-6
- Leak test methods G-3
  - Dye penetrant G-3
  - Halogen G-3

- Helium G-3
- Radioisotope G-3
- Ultrasonic G-3
- Water immersion G-3
- Leak testing G-1
  - Auto ranging 3-13
  - Manual ranging 3-14
- Leak types G-1
- Leak value 3-4
- LED indicator 3-1
  - Auto cal 3-2
  - Hold 3-2
  - Not ready 3-2
  - Reject 3-2
  - Start 3-2
  - Std leak 3-2
  - Test 3-2
  - Vent 3-2
  - Zero 3-2
- Liquid nitrogen 1-3, 1-12, 3-10, 4-9, 4-10, 4-12, 4-20, 4-23, B-19, B-22, B-26, B-30
- Locate leak by probe G-6
- Locate leak with tracer probe G-6
- Low pressure calibration 4-28
  - System pressure gauge calibration 4-28
  - Test port 4-30

## M

- Magnetic separation principle G-8
- Main valve block assembly 4-24
- Maintenance 4-1
  - As-required 4-3
  - Cleaning 4-1
    - Cleaning the spectrometer tube 4-16
    - Daily 4-5
    - Disassembling the spectrometer tube 4-14
    - Liquid nitrogen trap 4-9
    - Manual tuning 4-5
    - Oil level check 4-32
    - O-rings 4-2
    - Reassembling the spectrometer tube 4-17
    - Reinstalling the spectrometer tube 4-20
    - Removing the spectrometer tube 4-12
    - Replacing the air filter 4-21
    - Scheduled 4-3
    - Spare parts 4-36
    - TC1 gauge replacement in MVBA 4-24
    - TC2 gauge replacement in SBA 4-26
    - Tools and parts required 4-11
  - Manual ranging 3-14

- Manual tuning 4-5
- Mass spectrometer leak detector G-8
- Mass spectrometry principles G-4
- Model specifications E-1
- Model types and part numbers E-3
- Monitoring leak rate with the service pendant 3-16
- MSLD technique G-4
  - Leak rate G-5
  - Mass spectrometry principles G-4
  - Simplified description G-8
  - Vacuum flow G-4
- N**
  - Non-volatile operating parameters C-5
  - Normal operating mode 3-7
  - Not ready condition code 3-11
  - Not ready indicator 3-2, 3-11
  - Numerical notation-exponential system, definition of G-2
- O**
  - Oil level check 1-12, 4-32
  - Operating modes 3-3
  - Operating parameters
    - Command C-7
    - Internal C-2
    - Non-volatile C-5
    - Spectrometer C-6
  - Operation
    - Auto ranging 3-13
    - Calibration checks 3-12
    - Manual ranging 3-14
    - Sensitivity checks 3-12
    - Service pendant 3-16
    - Shutdown 3-15
    - Standby 3-15
    - Start-up controls 3-8
    - Start-up procedure 3-10
  - Operation description 947 1-2
  - Operation description 948 1-3
  - Optional interface
    - Electronic communications 2-5
  - O-rings 4-2, 4-13, 4-15, 4-18, 4-20, B-8
- P**
  - Parallel enable 2-11, 3-16
  - Parameter setup 3-3, 3-16
  - Parameters 3-3
    - Audio reject set points 3-5
    - Audio reject set points, enable / disable 3-5
    - Auto-range 3-3
    - Auto-sequencer 3-5
    - Calibrate 3-4
    - Calibrated leak value 3-4
    - Changing and viewing 2-9
    - Command C-7
    - Definitions 3-3
    - Internal operating C-2
    - Linear analog output 3-5
    - Log analog output 3-5
    - Manual range 3-3
    - Non-volatile operating C-5
    - Range 3-3
    - Range stop 3-4
    - Reject set points
      - Audio 3-5
      - Leak rate 3-5
      - Leak rate, enable/disable 3-5
    - Setting and display with service pendant 1-10
    - Spectrometer operating C-6
    - ZERO 3-4
  - Power 1-11
  - Power connection
    - Rear panel 1-9
  - Principles of mass spectrometry G-4
  - Probe to locate leak G-6
  - Protocol (RS-232) B-1, C-1
- R**
  - Rate-of-rise, definition of G-2
  - Rear panel
    - Circuit breakers 1-9
    - Interface connections, optional 1-13
    - Operation (option) 2-11
    - Power connection 1-9
    - Serial ports (option) 2-8
  - Reject function indicator 3-2
  - Removing
    - Spectrometer tube 4-22
  - Rough pump oil level check 1-12, 4-32
  - Rough time variable 3-6
- S**
  - Scheduled maintenance 4-3
  - Sealing with helium G-7
  - Sensitivity checks 3-12
  - Serial communications protocol B-1, C-1
  - Service block assembly 4-26
  - Service menu selection screen

- Gauge cal 4-27
- Service pendant 1-10, 2-9, 3-16, A-1, D-1
  - Function keys A-3
  - Input and data keys A-4
  - Keypad functions A-1
- Service serial interface D-1
- Setup 2-9
- Shutdown 3-15
- Signals
  - BCD discrete I/O parallel interface (option) D-3
  - Discrete I/O parallel interface (option) D-1
  - Host serial port interface (option) D-4
  - Service serial interface D-1
  - Universal remote control interface (option) D-4
- Spare parts 4-36
  - Independent mechanical parts 4-37
  - Parts for purchase for 947/948 4-36
  - Repair/exchange assemblies 4-36
- Spectrometer operating parameters C-6
- Spectrometer tube 4-10
  - Cleaning 4-16
  - Contamination 3-10
  - Disassembly 4-14
  - Exchange 4-22
  - Reassembly 4-17, 4-18, 4-19
  - Reinstallation 4-20, 4-22
  - Removal 4-12, 4-22
  - Tools and parts for overhaul 4-11
- Spectrometer tube exchange 4-22
- Standard leak test valve indicator 3-2
- Standby mode 3-15
- Start button indicator 3-2
- Start-up controls 3-8
- Start-up procedure 3-10
- Storage 1-13
- Symptoms and solutions 5-3
- System pressure (TC2) gauge calibration 4-28
- System pressure gauge calibration
  - Atmospheric 4-28
  - Vacuum (low pressure) 4-28

## T

- TC1 gauge replacement in MVBA 4-24
- TC2 gauge replacement in SBA 4-26
- Test mode indicator 3-2
- Test piece
  - Already sealed G-7
  - Evacuated G-6

- Pressurized G-6
- Test port pressure gauge calibration 4-29
  - Atmospheric 4-31
  - Vacuum (low pressure) 4-30
- Test time variable 3-7
- Testing for leaks G-1
- Testing procedures
  - Auto ranging 3-13
  - Manual ranging 3-14
- Tracer probe to locate leak G-6
- Transfer point set-up
  - Gross leak 3-7
- Troubleshooting
  - Error conditions 5-2
  - Symptoms and solutions 5-3

## U

- Unit storage 1-13
- Universal remote control interface (option) D-4
- Unpacking instructions 1-4

## V

- Vacuum calibration 4-28
  - System pressure 4-28
  - Test port 4-30
- Vacuum flow G-4
- Vacuum pumps 1-12
- Vacuum systems G-1
- Valve operation
  - Testing 2-3
- Vent valve indicator 3-2

## W

- Warranty 1-ii

## Z

- Zero 3-2, 3-4
- Zero button indicator 3-2





## Sales and Service Offices

### Argentina

#### Varian Argentina Ltd.

Sucursal Argentina  
Av. Ricardo Balbin 2316  
1428 Buenos Aires  
Argentina  
Tel:(54) 1 783 5306  
Fax:(54) 1 786 5172

### Benelux

#### Varian Vacuum Technologies

Rijksstraatweg 269 H,  
3956 CP Leersum  
The Netherlands  
Tel:(31) 343 469910  
Fax:(31) 343 469961

### Brazil

#### Varian Industria e Comercio Ltda.

Avenida Dr. Cardoso de Mello 1644  
Vila Olimpia  
Sao Paulo 04548 005  
Brazil  
Tel:(55) 11 3845 0444  
Fax:(55) 11 3845 9350

### Canada

#### Central coordination through:

Varian Vacuum Technologies  
121 Hartwell Avenue  
Lexington, MA 02421  
USA  
Tel:(781) 861 7200  
Fax:(781) 860 5437  
Toll Free: (800) 882 7426

### China

#### Varian Technologies - Beijing

Room 1201, Jinyu Mansion  
No. 129A, Xuanwumen Xidajie  
Xicheng District  
Beijing 1000031 P.R. China  
Tel:(86) 10 6641 1530  
Fax:(86) 10 6641 1534

### France and Wallonie

#### Varian s.a.

7 avenue des Tropiques  
Z.A. de Courtaboeuf – B.P. 12  
Les Ulis cedex (Orsay) 91941  
France  
Tel:(33) 1 69 86 38 13  
Fax:(33) 1 69 28 23 08

### Germany and Austria

#### Varian Deutschland GmbH

Alsfelder Strasse 6  
Postfach 11 14 35  
64289 Darmstadt  
Germany  
Tel:(49) 6151 703 353  
Fax:(49) 6151 703 302

### India

#### Varian India PVT LTD

101-108, 1st Floor  
1010 Competent House  
7, Nangal Raya Business Centre  
New Delhi 110 046  
India  
Tel:(91) 11 5548444  
Fax:(91) 11 5548445

### Italy

#### Varian Vacuum Technologies

Via F.lli Varian, 54  
10040 Leini, (Torino)  
Italy  
Tel:(39) 011 997 9 111  
Fax:(39) 011 997 9 350

### Japan

#### Varian Vacuum Technologies

Sumitomo Shibaura Building, 8th Floor  
4-16-36 Shibaura  
Minato-ku, Tokyo 108  
Japan  
Tel:(81) 3 5232 1253  
Fax:(81) 3 5232 1263

### Korea

#### Varian Technologies Korea, Ltd.

Shinsa 2nd Building 2F  
966-5 Daechi-dong  
Kangnam-gu, Seoul  
Korea 135-280  
Tel:(82) 2 3452 2452  
Fax:(82) 2 3452 2451

### Mexico

#### Varian S.A.

Concepcion Beistegui No 109  
Col Del Valle  
C.P. 03100  
Mexico, D.F.  
Tel:(52) 5 523 9465  
Fax:(52) 5 523 9472

### Taiwan

#### Varian Technologies Asia Ltd.

14F-16 No.77, Hsin Tai Wu Road Sec. 1,  
Hsi Chih, Taipei Hsien  
Taiwan, R.O.C.  
Tel:(886) 2 2698 9555  
Fax:(886) 2 2698 9678

### UK and Ireland

#### Varian Ltd.

28 Manor Road  
Walton-On-Thames  
Surrey KT 12 2QF  
England  
Tel:(44) 1932 89 8000  
Fax:(44) 1932 22 8769

### United States

#### Varian Vacuum Technologies

121 Hartwell Avenue  
Lexington, MA 02421  
USA  
Tel:(781) 861 7200  
Fax:(781) 860 5437  
Toll Free: (800) 882 7426

### Other Countries

#### Varian Vacuum Technologies

Via F.lli Varian, 54  
10040 Leini, (Torino)  
Italy  
Tel:(39) 011 997 9111  
Fax:(39) 011 997 9350

### Internet Users:

#### Customer Service and Technical Support:

[vpl.customer.support@varianinc.com](mailto:vpl.customer.support@varianinc.com)

#### Worldwide Web Site:

[www.varianinc.com/vacuum](http://www.varianinc.com/vacuum)

#### Order On-line:

[www.evarian.com](http://www.evarian.com)

Representatives in most countries



**VARIAN**