



Advanced Test Equipment Rentals
www.atecorp.com 800-404-ATEC (2832)

Portable Test Set

Type PTS-4

Instructions
Installation
Operation
Maintenance

SG-3138

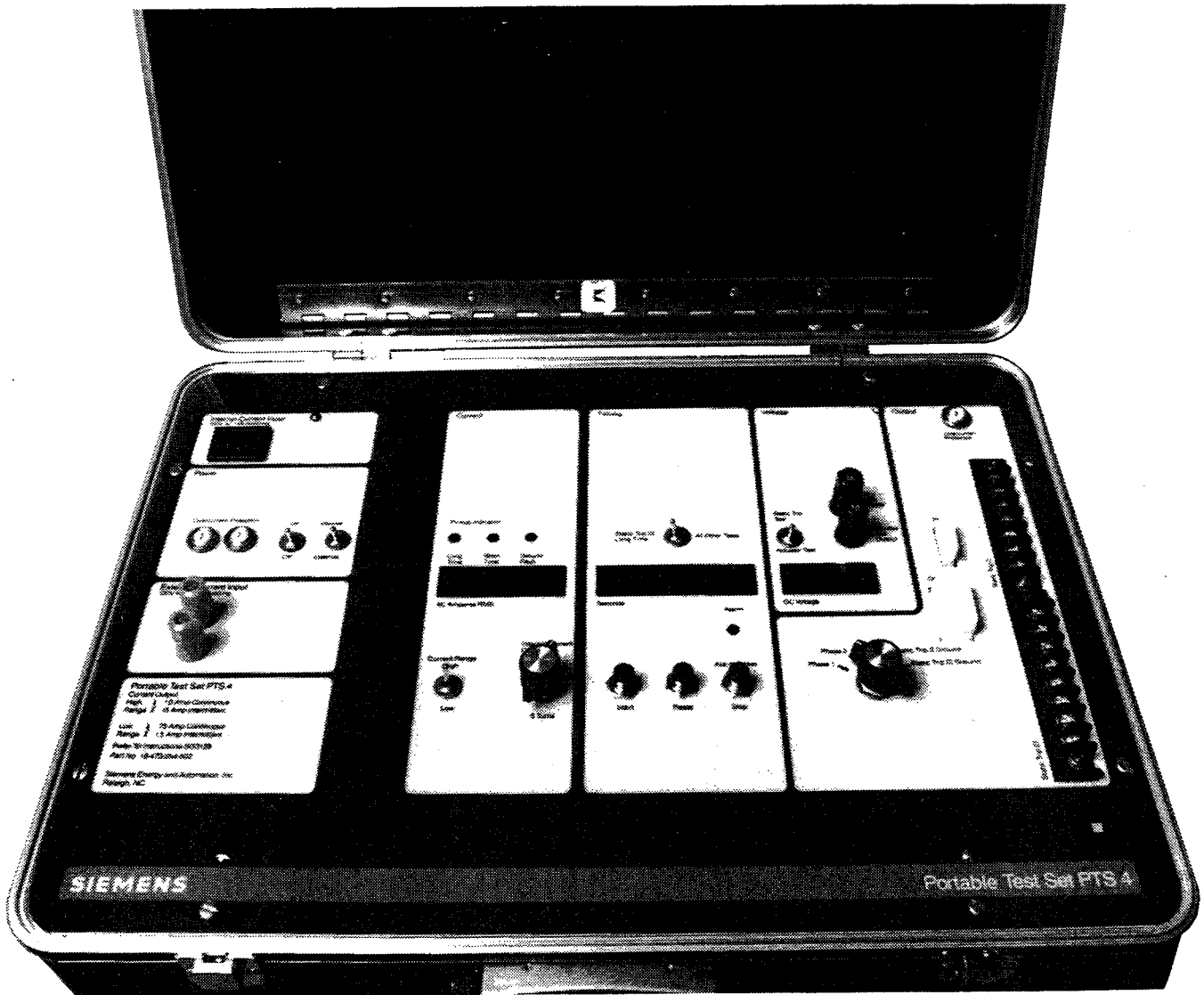

Table of Contents

	Page		Page
INTRODUCTION	1	Long Time Delay Test	15
General	1	Short Time Delay Test	15
Static Trip Calibration Marks	1	Ground Time Delay Test	15
Restoring Lost Calibration	1	Bench Testing Static Trip II Devices	17
DESCRIPTION	2	TESTING FIRST GENERATION TRIP DEVICES	18
Description	2	Connections—Use Cord Set 18-732-184-506	18
Rating	2	Test Procedures	19
Calibration	2	Bench Testing	25
Construction Details	2	Dual Device	25
Control Panel	3	TESTING LIMITRIP DEVICES	26
TESTING STATIC TRIP III Devices	6	General	26
Testing Static Trip Device on Circuit Breaker	6	Connections—Use Cord Set 18-732-184-507	26
Connections—Use Cord Set 18-732-184-508	6	Settings of Bands and Pick-Ups	28
Long Time Pick-Up Test	6	Test—Long Time Pick-Up	28
Short Time Pick-Up Test	8	Test—Short Time Pick-Up	29
Ground Pick-Up Test	8	Test—Instantaneous Pick-Up	29
Instantaneous Pick-Up Test	8	Test—Long Time Delay	29
Long Time Delay Test	8	Test—Short Time Delay	30
Short Time Delay Test	10	Bench Test—Limitrip Devices	30
Ground Time Delay Test	10	COMMENTS ON TEST RESULTS	31
Bench Testing Static Trip III Devices	10	TESTING THE TRIPPING ACTUATOR	32
TESTING STATIC TRIP II DEVICES	12	Testing the Actuator on the Circuit Breaker	32
Testing Static Trip Device on Circuit Breaker	13	Bench Testing Actuators	32
Connections—Use Cord Set 18-732-184-506	13	TESTING THE TRIPPING TRANSFORMERS	33
Long Time Pick-Up Test	14	Test Preparations	33
Short Time Pick-Up Test	14	Continuity Tests	33
Ground Pick-Up Test	14	Exciting Current Test	33
Instantaneous Pick-Up Test	14	REPAIR OF STATIC TRIP DEVICES	35

General

Siemens Energy & Automation portable test set type PTS-4 is designed for testing the static overcurrent tripping systems used on the LA and RL line of low voltage power circuit breakers. It provides a means of testing the magnetic tripping actuator as well as the static trip device. The portable test set, using power from an ordinary 120 volt convenience outlet, can provide circuit breaker testing equivalent to much more expensive and cumbersome primary current testing.

This instruction book provides the information necessary to test all models of static trip systems produced by Allis-Chalmers, Siemens-Allis or Siemens Energy & Automation from the original first generation models to the latest versions of STATIC TRIP III and LIMITRIP. First generation systems are discussed in more detail in instruction book 18X4392, STATIC TRIP II in books 18X4827, 18X4433 and SG-3098. LIMITRIP is covered in book 18X10107 and SG-3108. STATIC TRIP III in SG-3118.

Factory calibration of the trip devices is done with sinusoidal current from a closely regulated supply and with high quality instruments that are frequently recalibrated. These conditions cannot be duplicated in a portable tester. In particular, 120 volt line variations during testing may affect results. Therefore, minor discrepancies between factory calibration and test set readings can be safely disregarded.

The test set itself is quite accurate and can be used to calibrate additional pickup and short time delay values on the trip devices if a sufficiently stable 120 volt line is available. The voltage can be anywhere between 105 and 125 volts, but the value should not vary by more than $\pm 1.5\%$ during testing.

Static Trip III Calibration Marks

Each static trip of the first generation or STATIC TRIP II type, is individually calibrated during factory test. Because the location of the calibration points varies from device to device, it is not possible to preprint the identification letters adjacent to the marks. To identify a letter or label with its calibration dot, start from the reference dot (see "Restoring Lost Calibration") and count the calibration dots around the dial in the direction (clockwise or counterclockwise) indicated by the sequence of the letters or labels. For example, the "C" LONG TIME PICKUP dot is the third calibration dot counted clockwise from the reference dot. On STATIC TRIP II the direction of counting is also the direction indicated by the "increase" arrow.

Restoring Lost Calibration

The pointer of each knob when turned counterclockwise against its stop should line up with its reference dot. (Reference dots are black on STATIC TRIP II and red on first generation devices). If the pointer does not line up with its reference dot, the knob has turned on its shaft. To restore the knob to its proper location on the shaft, loosen the set screw in the knob, make sure the shaft is turned fully counterclockwise, align the pointer with the reference dot and tighten the set screw. Recheck that the pointer now aligns with the reference dot when it is rotated against its stop. On first generation devices the knob locks must be loosened in order that the shaft can be rotated.

LIMITRIP and STATIC TRIP III devices have no calibration marks since the settings of the device are made with switches, rather than potentiometers.

Description

The test set pictured in **Figures 1 and 2** show the Type PTS-4 Portable Test Set and a typical test set-up.



Figure 1. Portable Test Set

Rating

Input — 120 Volts, 50 or 60 Hz, 15 Amps Maximum.
Output — 0 to 120 Volts, 15 Amps Maximum.
Maximum continuous current on high scale 1.0 Amp.
Maximum continuous current on low scale 0.75 Amp.
DC output for actuator test — 0 to 22 Volts Open Circuit.

Calibration

Using an R.M.S. reading ammeter and sine wave current, the test set ammeter is factory calibrated on low scale at 0.50 amperes $\pm 1\%$ and on high scale at 3.00 amperes $\pm 1\%$. The electronic stop clock is factory calibrated at 300 seconds ± 5 seconds.

Construction Details

The test set is basically a variable voltage AC supply, with built in reactors to smooth the current against the trip device non-linear impedance. The output of the AC supply is controlled by a system of relays to start and stop the current. An electronic stop-clock is used to time the duration of current flow, and an ammeter to measure its magnitude. The relays are operated by the output of the trip device under test to stop the current. A small DC voltage source is built into the tester for use in testing the magnetic tripping actuator of the circuit breakers. The output of this small supply is monitored by a built-in digital voltmeter.

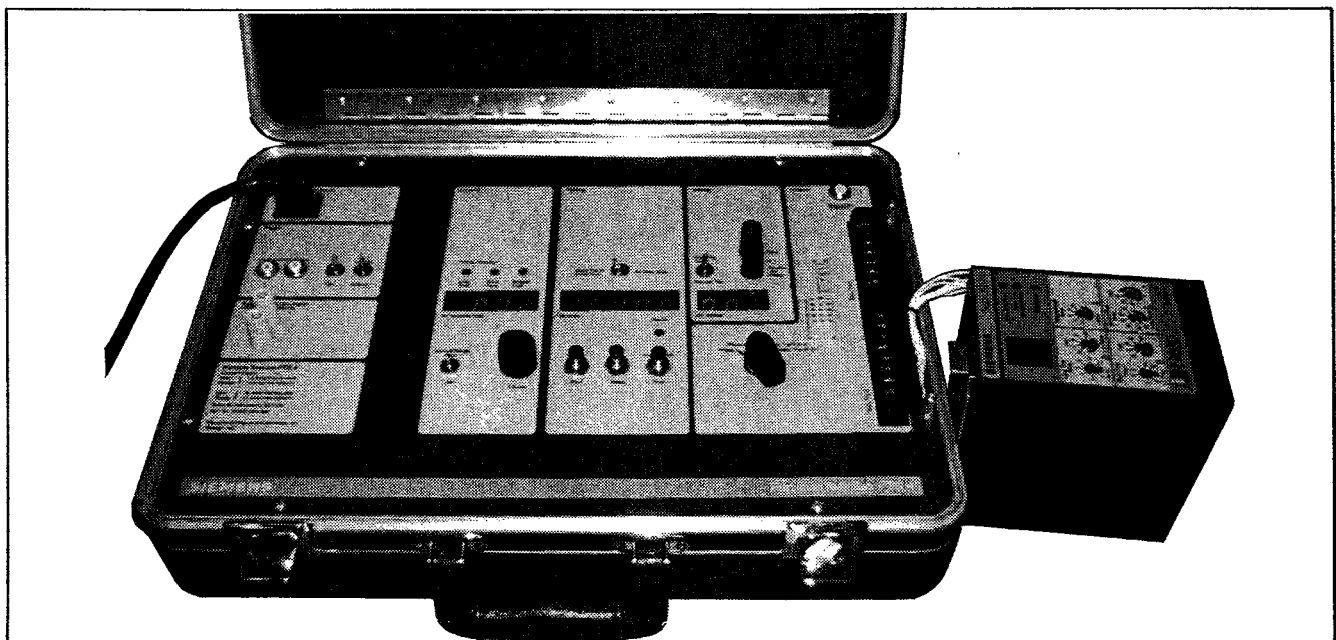

Figure 2. Bench Testing Static Trip Device

Control Panel Arrangement

See Figure 3.

1. Input circuit breakers, 8 ampere thermal trip, manual reset. One circuit breaker is installed in each line of the incoming line cord. The circuit includes an air core current limiting reactor permanently included in each line to limit the available short circuit current. In addition to the current limiting reactors and circuit breaker, the test set includes static overcurrent and ground fault interrupt circuitry.
2. On/Off Switch. This switch controls the input power to the test set control circuit. This switch must be ON for the test

3. Internal/External Power Selector Switch. This switch selects the current source for the test current. In the INTERNAL position the test current is controlled by the built in phase-controlled current source. In the EXTERNAL position the test current is controlled by an external variable transformer (not supplied with the test set). The output of the EXTERNAL transformer must be connected to the two binding posts labeled EXTERNAL POWER INPUT. The ON/OFF switch must be ON for the test set ammeter, timer and control relays to operate. The test current is then controlled by adjusting the external variable transformer; otherwise the operation of the test set is the

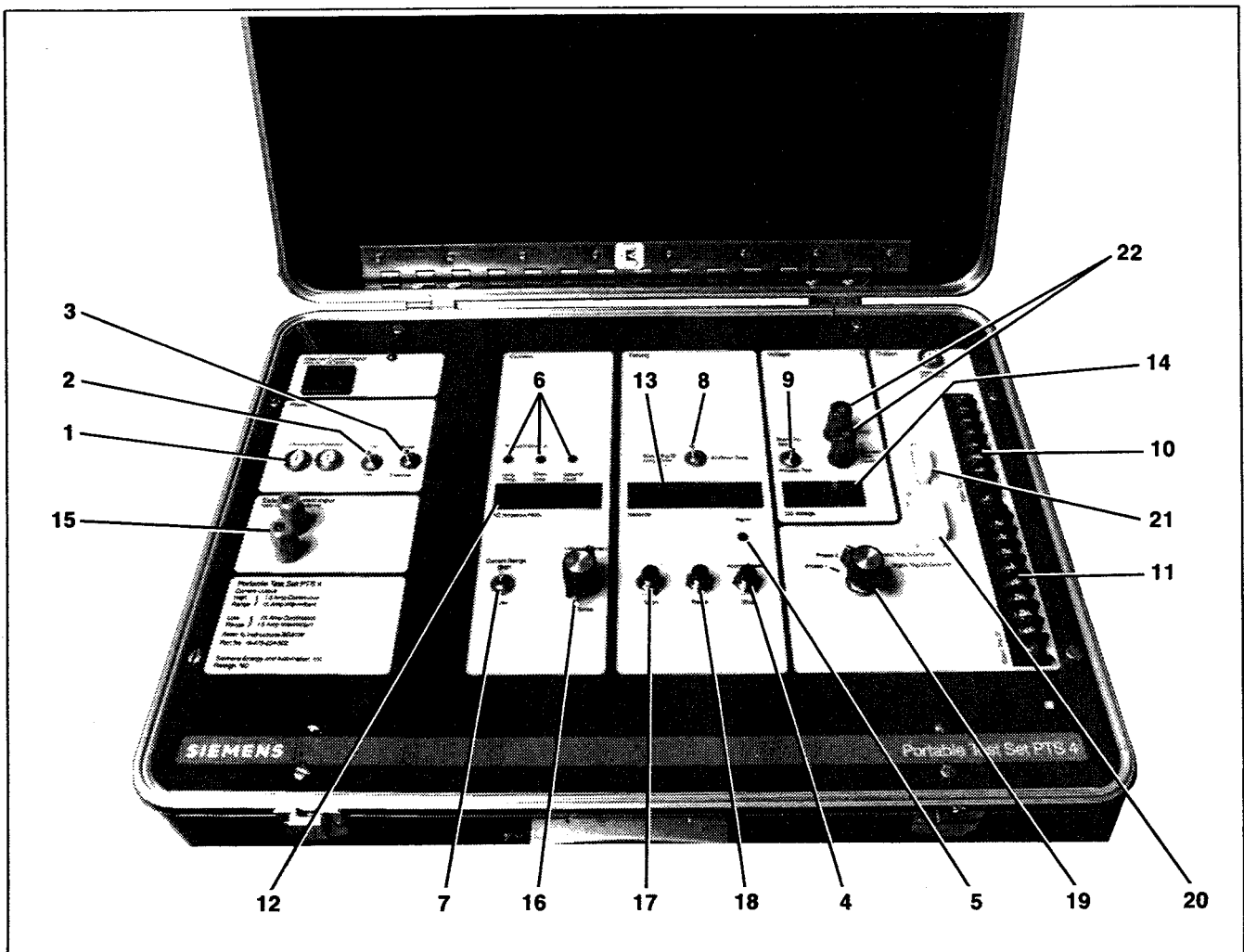

Figure 3. Control Panel

same in either case. This external connection may be useful when the incoming power is of poor quality so as to affect the phase control circuitry of the test set. The EXTERNAL position is also used to check the internal ammeter calibration.

4. Stop/Alarm Reset. This is a momentary push button that is used to turn off the current source of the test set when the trip device under test has not tripped. The switch stops the operation of the internal stop-clock and drops out the power control relay. The circuit is reset by pressing the reset pushbutton. The STOP button also resets the internal overcurrent and ground fault circuitry. Following an overcurrent trip, there is a delay before resetting will be successful.
5. Alarm Light. This is a light emitting diode that is turned on when either the overcurrent or the ground fault interrupt circuit operates. This circuit is reset by pressing the STOP push button.
6. Pick-Up Lights. These light emitting diodes connect directly to the test leads that attach to the trip device under test. When the external leads are properly connected the proper lights will be turned ON to indicate that the trip device has picked up. Three lights are provided; one for LONG TIME PICK-UP indicating that the long time circuit of the trip device has been released and the time delay circuit can operate, one for SHORT-TIME PICK-UP indicating that the short time circuit of the trip device is activated, and one for GROUND PICK-UP which indicates that the trip device ground circuit has been activated. Not all of the lights are used in all cases. For example, if the device under test has no ground circuit, the ground light is not used.
7. Range Switch. When in the LOW position, this switch inserts an additional current limiting air core reactor in series with the device under test. It also sets the internal ammeter to its LOW range. In its HIGH position the additional reactor is removed from the circuit and the internal ammeter is set to its HIGH range.
8. RMS/Peak Responding Switch. This switch selects response of internal ammeter (STATIC TRIP III/all other tests).
9. Static Trip Test/Actuator Test Selector Switch. When this switch is in the STATIC TRIP TEST position, the test current is supplied to the appropriate terminals of the device under test. In this position the internal VOLTMETER is isolated from the rest of the internal circuitry and the voltage applied to the DVM input terminals will be indicated by the voltmeter. When this switch is in the ACTUATOR TEST position the device current control circuit is connected to the primary winding of a small transformer/rectifier combination. The output of this small DC power supply is connected to the DVM INPUT-ACTUATOR TEST OUTPUT terminals, and the voltmeter indicates the voltage supplied by these terminals.
10. Seven Point Terminal Block. This terminal block is for convenience in bench testing STATIC TRIP II trip devices. The device fanning strip connects to the terminal block on the test set. The terminals are prewired so only the connections for pick-up indication are required.
11. Eight Point Terminal Block. This terminal block is for convenience in bench testing STATIC TRIP III trip devices. The terminal block is prewired internally so only the device fanning strip need be connected.
12. Dual Response Ammeter. When peak responding (all other tests) is selected the digital ammeter is constructed to respond to the peak value of the AC current with the scale reading in amperes RMS. The ammeter is calibrated with sinusoidal waveshape current. For other than sine waves, the ammeter indication is the RMS value for a sine wave with the same peak magnitude. In this way the ammeter approximates the response of the STATIC TRIP devices. When RMS (STATIC TRIP III LONG TIME) is selected the reading is in RMS, to match the response of STATIC TRIP III devices long time circuits. See **Item 8** for selector switch, marked STATIC TRIP III LONG TIME. Peak Responding is marked "All other Tests."
13. Electronic Stop-Clock. The stop clock indicates the time duration that current was supplied to the device under test. The time indicated is from initiation of current until the trip device operates a relay internal to the test set and includes the pick-up time of the internal relay which is about 5 to 10 milliseconds. For trip device testing this slight error can be safely ignored. Note that time values are always slightly longer than the actual operating time of the trip device.
14. Voltmeter. This is a digital meter circuit connected to the dvm INPUT/ACTUATOR TEST TERMINALS. The meter indicates 0 to 99 volts DC. (See **Item 9** for operation of the selector switch). The voltmeter is not usable externally when the internal power supply is connected to its terminals.
15. External Power Input Terminals. These terminals are used to inject current from an external variable transformer when this method of testing is used.
16. Internal Power Control. This is a five turn potentiometer that controls the internal phase controlled current source. This control is also used to adjust the voltage when the test set is used for testing the magnetic actuator of the circuit breaker.
17. Start Switch. This switch closes the relays in the test set to start current to the trip device under test. The relays latch themselves in and current is stopped when the trip

device under test trips or when the STOP push button is operated.

18. Reset Switch. This switch resets the relay circuit and the stop clock. It also changes the time constant for the peak responding ammeter allowing the ammeter to return to zero in a shorter time.
19. Phase Selector Switch. Selects phase of device to be tested.
20. Output Connector. This is a 15 pin connector that accepts the cord sets: three cord sets are provided with the test set. One cord set (18-732-184-506) provides the means of connecting to STATIC TRIP II type trip devices with the same color coded plugs as used in the previous (PTS-3) test set. With the addition of alligator clips this cord set is also used to test the first generation trip devices. A second cord set (18-732-184-507) is provided to con-

nect to LIMITRIP style trip devices. This cord set has coordinated color coding for the connections. A third cord set (18-732-184-508) is used to connect to STATIC TRIP III devices.

21. Pick-Up Connection. This is a four pin connector to the LED PICK-UP indicators for STATIC TRIP II and LIMITRIP.
22. DVM Actuator Test Output Terminals. These terminals, mentioned earlier, are the input of the digital voltmeter and when connected to the internal power supply by the STATIC TRIP TEST/ACTUATOR TEST switch, become the output to test the magnetic actuator of the circuit breaker. When used as the actuator source, the positive output is the red terminal and the negative is the black terminal. When used as the voltmeter input, the meter will read the same for either polarity.

NOTE

Keep I_{RT} out, ZSI out, and thermal memory off.

Trip devices can be tested when mounted on a circuit breaker in the disconnect position in its cubicle, with the device on a circuit breaker removed from its cubicle or with the device separate from the circuit breaker.

The following instructions cover testing of all the elements for the most complicated type of trip device. Other types do not contain all these elements. See the listing and description of available types in **Table 1**.

The selector switch must be in the "STATIC TRIP TEST" position for all static trip device tests. The ammeter range switch should be in the "LOW" position for all tests below 1.5 amperes, and in the "HIGH" position for all tests above 1.5 amperes. Current must be re-adjusted when changing ranges since the switch also inserts an additional current limiting reactor when in the "LOW" range position.

Testing Static Trip Device on Circuit Breaker



CAUTION

The static trip circuit is capacitively coupled to the circuit breaker frame. Therefore, to insure against electrical shock be sure to ground the frame when testing with the circuit breaker out of the cubicle.

NOTE

The test set isolates the power source from its output leads by an open relay contact in each line except when a test is being run. In the case of excessive ground current, the test set will trip out and light the ALARM light.

Connections — Use Cord Set 18-732-184-508

Figure 4 shows how to connect the test set leads to the trip device. The cord set connector makes all of the connections required. The phase selector switch is used to select the appropriate terminals.

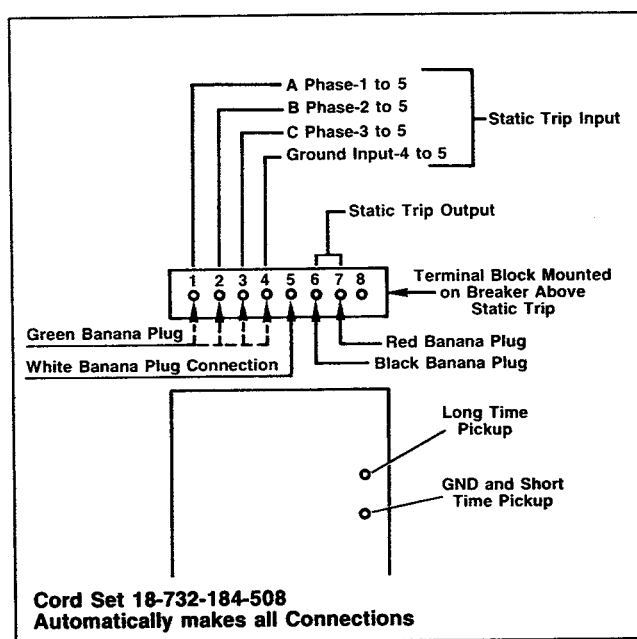

Figure 4. Test Connections for Static Trip III

Long Time Pick-Up Test

1. Use phase selector switch to select phase 1, 2 or 3, as desired.
2. Set "LONG TIME PICK-UP" on 0.5. Place the selector switch to "STATIC TRIP TEST" position. Set the RANGE switch on "LOW." Set the POWER selector switch to "INTERNAL". Set ammeter to RMS responding, STATIC TRIP III Long Time.
3. Turn the power switch to "ON." The red digits of the meters should come ON. (The alarm light may also come ON. If so, press the "STOP" alarm reset button.) Press the "START" push button to initiate current.
4. Slowly increase the current by rotating the "INTERNAL

POWER CONTROL in a clockwise direction. This is a five turn control arranged for 50 Hz operation so a noticeable deadband is evident at zero output and 60 Hz. Increase the current until the LONG TIME pick-up light comes ON. This should be at .275 ampere \pm 10%. The sampling rate of the ammeter is such that the control must be moved very slow-

- ly to accurately determine the pick-up current of the trip device. The pick-up is always 110% of long time setting.
- 5. Decreasing the current should cause the light to go out.
- 6. Repeat the tests for the other phases and settings and compare with **Table 1**.

Table 1

Long Time Element Calibrated Current Settings												Ground Element Calibrated Pickup Settings					
Sensor Rating (Pri-Amps)	.5	.55	.6	.65	.7	.75	.8	.85	.9	.95	1.0	Sensor Rating Primary Amps	20%	30%	40%	50%	60%
150	75	82.5	90	97.5	105	112.5	120	127.5	135	142.5	150	150	30	45	60	75	90
200	100	110	120	130	140	150	160	170	180	190	200	200	40	60	80	100	120
300	150	165	180	195	210	225	240	255	270	285	300	300	60	90	120	150	180
400	200	220	240	260	280	300	320	340	360	380	400	400	80	120	160	200	240
600	300	330	360	390	420	450	480	510	540	570	600	600	120	180	240	300	360
800	400	440	480	520	560	600	640	680	720	760	800	800	160	240	320	400	480
1200	600	660	720	780	840	900	960	1020	1080	1140	1200	1200	240	360	480	600	720
1600	800	880	960	1040	1120	1200	1280	1360	1440	1520	1600	1600	320	480	640	800	960
2000	1000	1100	1200	1300	1400	1500	1600	1700	1800	1900	2000	2000	400	600	800	1000	1200
3200	1600	1760	1920	2080	2240	2400	2560	2720	2880	3040	3200	3200	400	600	800	1000	1200
4000	2000	2200	2400	2600	2800	3000	3200	3400	3600	3800	4000	4000	400	600	800	1000	1200
Secondary Current Amps	.25	.275	.30	.325	.35	.375	.40	.425	.45	.475	.50						

Available Models

- RMS-TI(T) Long Time and Instantaneous
- RMS-TIG(T,Z) Long Time, Instantaneous and Ground Fault
- RMS-TS(T,Z) Long Time and Short Time
- RMS-TSG(T,Z) Long Time, Short Time and Ground Fault

- RMS-TSI(T,Z) Long Time, Short Time and Instantaneous
- RMS-TSIG(T,Z) Long Time, Short Time, Instantaneous and Ground Fault

Devices with (T,Z) designation include optional targets (T) and/or zone interlocking (Z).

General Notes

1. The "Tripping XFMR Rating" STATIC TRIP III represent the primary current in amperes. The secondary rated value is one half ampere.
2. The current settings of the long time element are switch selectable and are calibrated at points .5 through 1.0 as shown in the rating table. Pickup is 1.1 times the setting.
3. The pick-up setting of the short time delay element is switch selectable and is calibrated at 2,3,4,5,6,7,8 and 12 multiples of the long time setting.
4. Instantaneous calibration at 2,4,6,8, 12 and 15 multiples of tripping XFMR rating.
5. The pick-up settings of the ground elements are switch selectable and are calibrated in multiples of the tripping transformer rating as shown in the rating table.
6. The long time element has 5 bands which are field selectable. The time delay at 6 multiples of pick-up is as follows:
 Band 1 — 3.5 seconds Band 4 — 17 seconds
 Band 2 — 6.0 seconds Band 5 — 30 seconds
 Band 3 — 10 seconds
7. The ground element has 3 bands which are calibrated at 1, 25 and 4 seconds.
8. The short time element has 5 time bands.
9. The maximum interrupting time is the maximum length of time that fault current flows, including arcing time.
10. The lower limit of ground fault recognition is 25 amperes for RL-800 breakers and 40 amperes for an RL-1600 breaker.

NOTE

The illumination of the "PICK-UP" light indicates that the timed delay has started. If the current drops slightly, the light will go out, the timing circuit may reset instantly and timing will start over upon the next appearance of triggering.

The static trip device level sensing circuits have a slight amount of hysteresis. That is the pick-up and drop-out points of the circuit are very nearly but not exactly the same value. If the input current is modulated in amplitude the pick-up will flash ON and OFF, and the timing circuit can never time out.

Short Time Pick-Up Test

1. Set ammeter to peak responding (All Other Testing), select desired phase.
2. Set LONG TIME CURRENT SETTING on .5, INSTANTANEOUS 15X, LONG TIME BAND on 30 and SHORT TIME PICK-UP on 2X.
3. Press the START button.
4. Slowly increase the current until the SHORT TIME PICK-UP light comes ON. This should occur at 0.5 amperes $\pm 10\%$. This is the 2X long time current setting.
5. Repeat for other SHORT TIME PICK-UP settings as desired. The RANGE switch must be set on HIGH for currents above 1 ampere. To avoid overheating, do not maintain the higher currents any longer than necessary.

Ground Pick Up-Test

1. Select ground with power boost.
2. Set GROUND PICK-UP on 0.2.
3. Press the START button and raise the current gradually until the GROUND PICK-UP light turns ON. This should occur at .10 ampere $\pm 15\%$, repeat for the 0.3 and other settings. See **Table 1** for the settings in amperes.

NOTE

If the output of the trip device is connected to the tripping actuator of the circuit breaker, the additional current drawn during tripping may cause confusion. Either disconnect the actuator or set the ground time delay to its MAXIMUM to allow time to read the meter before actual tripping occurs.

Instantaneous Pick-Up Test

There is no pick-up LED output for INSTANTANEOUS TRIP, but tripping of the circuit breaker and/or operation of the test set relay will indicate instantaneous trip operation.

1. Select the desired phase with the phase selector switch.
2. Set LONG TIME CURRENT SETTING on .5, LONG TIME BAND on 30, SHORT TIME PICK-UP 12X and INSTANTANEOUS PICK-UP ON 2X, ammeter on "All Other Tests."
3. Press the START button.
4. Raise the current slowly until the relay in the test set operates. This can be determined audibly and should occur at 1.0 amperes $\pm 10\%$. This is 2 times breaker rating.
5. Repeat for the other settings as desired. Avoid maintaining high currents longer than necessary to obtain the readings. On some static trips the relay can be heard to "buzz" when the current is held exactly at the PICK-UP value. This is due to the output transistor turning ON and OFF as the current varies. Operation of the relay should be positive if the current is increased by 2 or 3% above the pick-up value.

Long Time Delay Test

If the time delay is tested at an input current 6 times the pick-up setting, the nominal time delays will be as marked on the trip device. Maximum and minimum limits can be determined by references to the time current characteristic curves, **Figure 5**.

1. Select the desired phase to be tested.
2. Set LONG TIME CURRENT SETTING on .5, LONG TIME BAND on 3.5, SHORT TIME and INSTANTANEOUS PICK-UPS on 12X and SHORT TIME BAND on MAXIMUM .40.
3. Press the START button and adjust the current to 1.5 amperes (6X .5 pick-up).
4. In turn, press the STOP and the RESET buttons. Allow time for the ammeter reading to reach zero.
5. Press the START button. (It is not necessary to hold this button. Power will be maintained until the Static Trip times out.)
6. When the trip device operates, check the reading of the stop clock against the curves in **Figure 5**. The reading should be approximately the same as shown on the faceplate of the device, but must be within the limits shown on the curves. If not, recheck all settings and repeat the test.
7. Repeat steps 5 and 6 one or more times to verify the test results.
8. Repeat for the other phases (by changing the phase selector switch) time delay bands and other values of current, as desired. All test points should fall within the bands of **Figure 5**.

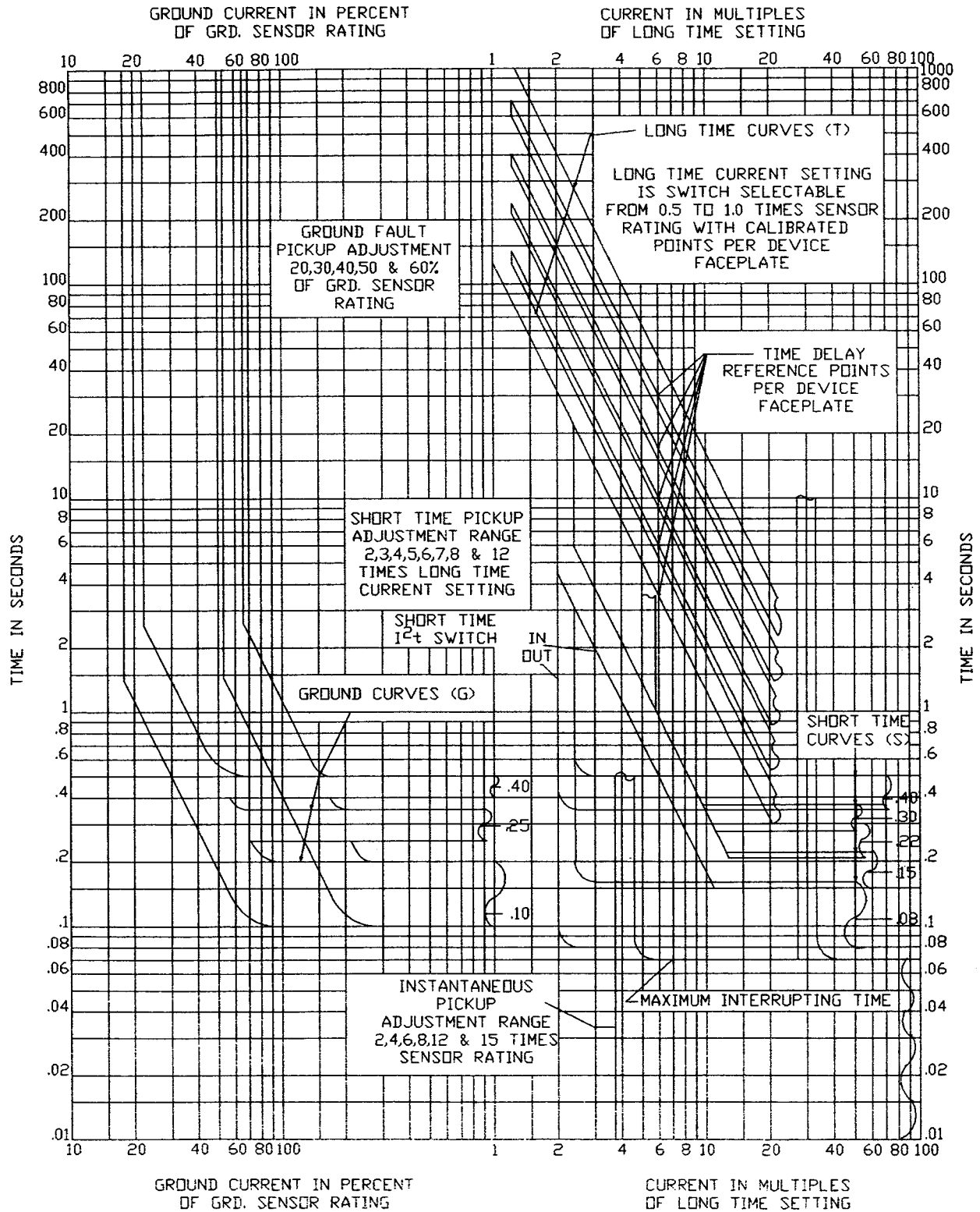

Figure 5. Time Current Curves—Static Trip III

NOTE

When timing at values of current only slightly above pick-up, line voltage fluctuations may cause detripping and result in erroneous operating times. Therefore, it is advisable to watch the long time pick-up light to note whether trigger voltage is maintained. In general, it is impractical to test time delay at less than 10% above pick-up.

Short Time Delay Test

1. Set LONG TIME CURRENT SETTING .5, LONG TIME BAND on 30, INSTANTANEOUS PICK-UP "15X," SHORT TIME PICK-UP on 2X (0.5 Amperes) and SHORT TIME BAND on MAXIMUM .40.
2. Press the START button and adjust the current to 1 ampere or more. In turn, press the STOP and the RESET buttons.
3. Close the circuit breaker, if desired.
4. Press the START button, the delay should be .35 to .50 seconds. See **Figure 5**.
5. Repeat for SHORT TIME BAND settings on the other delay bands. Compare to **Figure 5**. The other phase circuits and different values of current can be tested if desired. Make current settings as quickly as possible to avoid overheating.

Ground Time Delay Test

1. Select ground with power boost, STATIC TRIP III GROUND.
2. Set GROUND PICK-UP on 20% (0.10 ampere) and GROUND TIME BAND on "Maximum," .40.
3. Press the START button and adjust the current to 0.5 ampere or more. (Erroneous time delay readings and failure to trip the circuit breaker or target may occur at lower values of current. The waveshape of current from the test set may not provide enough power to charge the filter capacitor in the trip device before tripping occurs. By running the test at a higher current this effect is minimized). In turn press the STOP and the RESET button.
4. Close the circuit breaker, if desired.
5. Press the START button. The breaker should trip in 0.4 and 0.5 seconds. See **Figure 5**.
6. Repeat for other GROUND TIME BAND settings and for other pick-up and current settings, if desired. Make current adjustments above 1 ampere quickly to avoid overheating.

Bench Testing Static Trip III Devices

Connections

With the static trip device away from the circuit breaker it is necessary to make connections to the fanning strip of the trip device via the connector supplied. A terminal block is provided on the test set to facilitate this connection. The end of the connector strip next to the cord must connect to terminal 1, a spacer under one mounting screw of the test set faceplate provides interference if the connections are made incorrectly.

The terminal block is connected internally, so the phase selector switch is used.

Test Procedure

The testing procedures are exactly the same as given in TESTING THE STATIC TRIP ON THE CIRCUIT BREAKER except, of course, any reference to the circuit breaker is ignored.

Some STATIC TRIP III DEVICES may contain circuit functions that are not completely tested by the relatively simple portable test set. These are described in the following sections.

Zone Selective Interlock Tests

On devices with the Zone Selective Interlock selected both the SHORT TIME and the GROUND TIME delay bands are affected by the incoming ZSI signal. With no incoming ZSI signal both time bands will be on their minimum, when an incoming ZSI signal is present both the SHORT TIME and GROUND delay element switch to the band selected by the front panel controls.

On devices containing the ZSI function, the ZSI output circuit provides an output signal anytime either the SHORT TIME or GROUND pick-up values are exceeded.

Both the incoming and outgoing ZSI circuits are isolated by an optical isolator inside the device, so some power must be provided either externally or by making connections to the trip devices own power supply.

Both sets of signals are brought out on the 15 pin sub "D" connector.

- Pin 1 and 2 are the device negative power.
- Pin 3 is the device +12 volt power.
- Pin 4 is the +5 volts from the target power supply.
- Pin 5 is the ZSI positive signal input.
- Pin 6 is the ZSI negative signal input.
- Pin 7 is the ZSI negative signal output.
- Pin 8 is the ZSI positive signal output.

The ZSI output is an isolated transistor that can be checked with an ohmmeter, or by using a dropping resistor and connecting both the devices positive and negative power supply and detecting turn-on of the transistor with a voltmeter. This transistor turns ON when either SHORT TIME or GROUND elements have picked-up.

A resistor of approximately 220 ohms should be used to limit the current through the transistor during testing. Connect the resistor from pin 3 to pin 8, connect pin 7 to pin 1 or 2. Measure the voltage between pins 7 and 8.

To check the operation of the ZSI input circuit set the SHORT TIME and GROUND TIME BANDS to .40, so that a difference in timing can be detected. Open the SHORT TIME I²t SLOPE switch. Run the time delay test as described previously, then at the 15 pin connector connect pin 5 to pin 4 and pin 6 to pin 1 or 2 and repeat the timing tests. The time delay should then change to the selected band.

If the I²t slope switch is closed the incoming ZSI signal will not change the time delays unless the current used in the test is above the range where the SLOPE circuits affect the delay.

Long Time Cool Down Tests (Thermal Memory)

The cool down integrator accumulates the LONG TIME signal and provides a cool down function for the LONG TIME delay. Closing the thermal memory switch disables the integrator and allows the long time delay elements to reset whenever the long time signal drops below pick-up. When the thermal memory switch is open the long time delay elements are not reset when the signal drops below pick-up, but is decreased slowly with time.

To check the operation of the circuit set LONG TIME PICK-UP on .5 LONG TIME BAND on 1, close the thermal memory switch. Apply 0.5 amperes to one phase input, allow the device to time out, record the time. Open the thermal memory switch and repeat the same test, again record the time, it should be the same as the first test.

Repeat the test but this time momentarily lower the current to 0.15 to 0.2 ampere for approximately 5 seconds every 10 seconds. Be very careful to not drop below 0.15 amperes. Again measure and record tripping time, this should be approximately the same as for the first two tests. Close the thermal memory switch and repeat this test, in this case the device should never time out, and it should be possible to continue the cycle indefinitely.

Remote Indicator Output Tests

All STATIC TRIP III trip devices have a nine pin connector on the front of the device to connect to the remote indicator unit. If the remote indicator is available it can be used to test the output signals, if there is a malfunction between the two assemblies, substitution of either unit is the best field test to isolate the defective assembly.

The output signal is a four bit, latched, parallel binary word representing the calculated RMS current in the highest phase that is provided to the remote indicator. This word is on pins 2 through 5 of the nine pin connector, with the following code:

Binary Word	Switch	Current, in Multiples of Long Time Pick-Up
0000		
0001	1	0.6X
0010	2	0.7X
0011	3	0.8X
0100	4	0.9X
0101	5	1.0X This is Long Time Pick-Up Current
0110	6	1.1X
0111	7	1.2X
1000	8	1.3X
1001	9	1.4X

The connector also contains +5 volts on pin 1 to power the remote indicator. The negative or common line is on pin 9. Pin 8 is a signal called NOT RESET this signal is used to enable the remote indicator and is +5 volts DC when current above approximately 100 milliamperes is supplied to the trip device, below this input level none of the data is valid. All pins can be checked with a voltmeter, while the current is adjusted as desired, some dithering of the LED is normal and should be ignored.

The remote indicator assembly decodes the number and drives a light emitting diode bar display, to indicate the magnitude of current. The indicator also contains a switch and circuitry that selects any one of the current levels indicated and closes a solid state contact when that level is exceeded. The table lists the switch marking and the current levels.

The solid state contact is rated 1 ampere max. 125VDC or AC, nominal.

It is not necessary to operate the circuit breaker for any static trip device tests. If it is desired to test the operation of the circuit breaker, the tests can be run with the circuit breaker closed and allowing the trip device to open the breaker.

Trip devices can be tested when mounted on a circuit breaker in the disconnect position in its cubicle, with the device on a circuit breaker removed from its cubicle or with the device separate from the circuit breaker.

The following instructions cover testing of all the elements for the most complicated type of trip device. Other types do not contain all these elements. See the listing and description of available types in **Table 2**.

Table 2

Breaker Frame Size Type	Tripping XFMR Rating (Primary Ams)	Long Time Element Calibrated Pick-Up Settings†							Max. Cont. Rating	Ground Element Calibrated Pick-Up Settings			
		A	B	C	D	E	F	G		15%	25%	50%	100%
800A Frame: RL-800 RLF-800	80	40	50	60	70	80	90	100	100	θ	θ	40	80
800A Frame: RL-800 RLF-800 RLX-800	200 400 800	100 200 400	125 250 500	150 300 600	175 350 700	200 400 800	225 450 900*	250 500 1000*	250 500 800	θ 60 120	50 100 200	100 200 400	200 400 800
1600A Frame: RL-1600 RLX-1600 RLF-1600	200 400 800 1600	100 200 400 800	125 250 500 1000	150 300 600 1200	175 350 700 1400	200 400 800 1600	225 450 900 1800*	250 500 1000 2000*	250 500 1000 1600	θ 60 120 240	50 100 200 400	100 200 400 800	200 400 800 1600
2000A Frame RL-2000 RLF-2000	200 400 800 1600 2000	100 200 400 800 1000	125 250 500 1000 1250	150 300 600 1200 1500	175 350 700 1400 1750	200 400 800 1600 2000	225 450 900 1800 2250*	250 500 1000 2000 2500*	250 500 1000 2000 2000	θ 60 120 240 300	50 100 200 400 500	100 200 400 800 1000	200 400 800 1600 2000
3200A Frame: RL-3200 RLF-3200	1600 2000 2400 3200	800 1000 1200 1600	1000 1250 1500 2000	1200 1500 1800 2400	1400 1750 2100 2800	1600 2000 2400 3200	1800 2250 2700 3600*	2000 2500 3000 4000*	2000 2500 3000 3200	240 300 360 480	400 500 600 800	800 1000 1200 1600	1600 2000 2400 3200
4000A Frame: RL-4000 RLF-4000	3200 4000	1600 2000	2000 2500	2400 3000	2800 3500	3200 4000	3600 4500*	4000 5000*	4000 4000	480 600	800 1000	1600 2000	3200 4000

* Exceeds maximum continuous current rating of frame—do not use these settings.
θ Breaker may not trip with this ground fault setting.

† Long time element continually adjustable from A through G.

Types Available

TI(0T) Long Time and Instantaneous
 TS(0T): Long Time and Short Time
 TSI(0T): Long Time, Short Time and Instantaneous
 TI(2T): Long Time and Instantaneous
 TS(2T): Long Time and Short Time
 TSI(2T): Long Time, Short Time and Instantaneous
 TIG(3T): Same as T(2T), plus Ground Fault

TSG(3T) Same as TS(2T), plus Ground Fault
 TSIG(3T) Same as TSI(2T), plus Ground Fault

Devices with (0T) designation do not include targets.

Devices with (2T) designation include targets to indicate overload trip and short circuit trip, while those with (3T) designation also include a ground trip target.

General Notes

- The TRIPPING XFMR RATING values represent the primary value of the current transformer ratio in amperes. The secondary value is one ampere.
- The pick-up settings of the long time element are continuously adjustable and are calibrated at points "A" through "G" as shown in the rating table.
- The pick-up settings of the instantaneous and short time delay elements are continuously adjustable, and are calibrated at 3, 5, 8 and 12 multiples of the long time pick-up setting.
- The pick-up settings of the ground elements are continuously

adjustable, and are calibrated in percent of the tripping transformer rating as shown in the rating table.

5. The long time element has 6 bands which are field selectable. The time delay at 6 multiples of pick-up is as follows:

- | | |
|---------------------|-------------------|
| Band 1—1.12 Seconds | Band 4—9 Seconds |
| Band 2—2.25 Seconds | Band 5—18 Seconds |
| Band 3—4.5 Seconds | Band 6—36 Seconds |



6. The short time element and ground element has 3 bands which are calibrated at minimum, intermediate and maximum, but are continuously adjustable.

7. The maximum interrupting time is the maximum length of time that fault current flows, including arcing time.

8. Instantaneous maximum interrupting time may be greater when breakers are closed in on a fault depending on actual fault conditions. The maximum potential increase for a 3-phase fault is 0.01 seconds and for a single-phase ground fault is 0.02 seconds.

9. The lower limit of ground fault recognition is 25 amperes for RL-800 or RLF-800 and 40 amperes for the RLX-800, RL-1600, RLX-1600 and RLF-1600.

Testing Static Trip Device on Circuit Breaker

	 CAUTION
	<p>The static trip circuit is grounded to the circuit breaker frame through a surge capacitor. Therefore, to insure against electrical shock be sure to ground the frame when testing with the circuit breaker out of the cubicle.</p>

<h3>NOTE</h3>
<p>The test set isolates the power source from its output leads by an open relay contact in each line except when a test is being run. In the case of excessive ground current, the test set will trip out and light the ALARM light.</p>

Connections—Use Cord Set 18-732-184-506

Figure 6 shows how to connect the test set leads to the trip device. The red and black banana plugs may be left disconnected for pick-up tests to avoid trigger instability. However, to operate the stop clock they must be connected to terminals

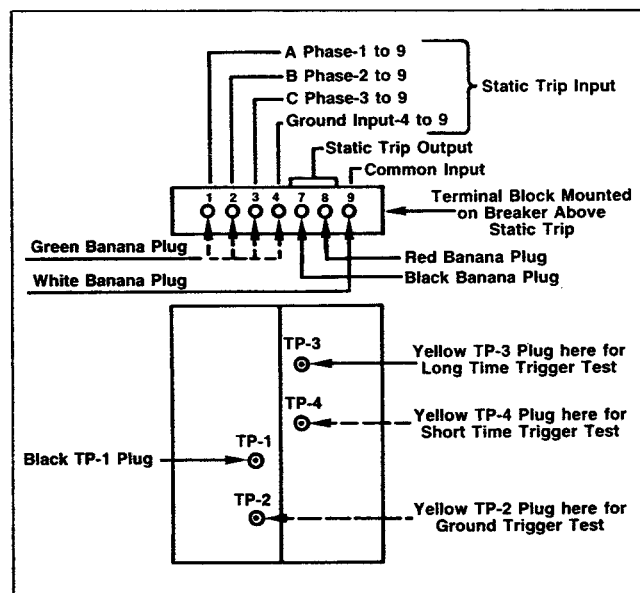

Figure 6. Test Connections for Static Trip II

8 and 7 as shown. In some cases, it may be desirable to disconnect these leads to prevent false indications when testing the circuit breaker tripping action since the relay circuit may operate faster than the circuit breaker. It is not necessary to operate the circuit breaker for any static trip device tests. If it is desired to test the operation of the circuit breaker, the above tests can be run with the circuit breaker closed and allowing the trip device to open the breaker. Disconnect either the red or black lead from the trip device to assure that the relay in the test set does not interrupt the current before the circuit breaker can open thus confusing the test results when operating the circuit breaker.

NOTE

The illumination of the "PICK-UP" light indicates that the time delay has started. If the current drops slightly, the light will go out, the timing circuit resets instantly and timing will start over upon the next appearance of tripping.

The static trip level sensing circuits have a very slight amount of hysteresis. That is, the pick-up and drop-out points of the circuit are very nearly but not exactly the same value. If the input current is modulated in amplitude the pick-up light will flash ON and OFF, and the timing circuit can never time out.

Long Time Pick-Up Test

1. Leave the red and black banana plugs disconnected. To test phase 1 connect the green plug to terminal 1 and the white plug to terminal 9. Connect the black pin plug to TP-1 and the yellow pin plug (TP-3) to terminal TP-3 of the trip device.
2. Set LONG TIME PICK-UP on "A." Place the selector switch to STATIC TRIP TEST position. Set the RANGE switch on LOW. Set the POWER selector switch to INTERNAL, set phase selector to phase 1.
3. Turn the other power switch to ON. The red digits of the meters should come ON. (The alarm light may also come ON. If so, press the STOP—alarm reset button). Press the START push button.
4. Slowly increase the current by rotating the INTERNAL POWER CONTROL in a clockwise direction. This is a five turn control arranged for 50Hz operation so a noticeable deadband is evident at zero output and 60Hz. Increase the current until the LONG TIME PICK-UP light comes ON. This should be at 0.5 ampere $\pm 10\%$. The sampling rate of the ammeter is such that the control must be moved very slowly to accurately determine the pick-up current of the trip device.
5. Decreasing the current slightly should cause the light to go OUT.
6. Repeat the tests for the other phases and settings and compare with **Table 2**.

Short Time Pick-Up Test

1. Connect the yellow (TP-4) pin plug to the TP-4 terminal of the trip device, the black pin plug to TP-1, the green plug to terminal 1, and the white plug to terminal 9.
2. Set LONG TIME PICK-UP on "A," INSTANTANEOUS fully counterclockwise, LONG TIME BAND on 6 and SHORT TIME PICK-UP on 3X.
3. Press the START button.
4. Slowly increase the current until the SHORT TIME PICK-UP light comes ON. This should occur at 1.5 amperes $\pm 10\%$.
5. Repeat for SHORT TIME PICK-UP settings of 5X, 8X, and 12X. The RANGE switch must be set on HIGH for these tests. To avoid overheating, do not maintain the higher currents any longer than necessary.

Ground Pick-Up Test

1. Connect the green plug to terminal 4 and the white plug to terminal 9, connect the black pin plug to TP-1 and the yellow (TP-2) pin plug to TP-2 on the trip device.
2. Set GROUND PICK-UP on the 15% dot.
3. Press the START button and raise the current gradually until the Ground pick-up light turns ON. This should occur at .15 ampere $\pm 15\%$, repeat for the 25% and other settings. See the bottom line of Table 1 for the settings in amperes.

NOTE

If the output of the trip device is connected to the tripping actuator of the circuit breaker, the additional current drawn during tripping may cause confusion. Either disconnect the actuator or set the ground time delay to its MAXIMUM to allow time to read the meter before actual tripping occurs.

Instantaneous Pick-Up Test

There is no trigger output for INSTANTANEOUS TRIP, but tripping of the circuit breaker and/or operation of the test set relay will indicate instantaneous trip operation. To operate the test set relay, the red and black banana plugs must be connected to the trip device.

1. Connect the green banana plug to terminal 1 and the white one to terminal 9; the pick-up pin plugs are not needed.

2. Set LONG TIME PICK-UP on "A," LONG TIME BAND on 6, SHORT TIME PICK-UP fully counter-clockwise, and INSTANTANEOUS PICK-UP ON 3X.
3. Press the START button.
4. Raise the current slowly until the relay in the test set operates. This can be determined audibly and should occur at 1.5 amperes \pm 10%.
5. Repeat for the other settings as desired. Avoid maintaining high currents longer than necessary to obtain the readings. On some static trips the relay can be heard to "buzz" when the current is held exactly at the PICK-UP value. This is due to the output transistor turning ON and OFF as the current varies. Operation of the relay should be positive if the current is increased by 2 or 3% above the pick-up value.

Long Time Delay Test

If the time delay is tested at an input current 6 times the pick-up setting, the nominal time delays will be as shown in the table on the trip device. Maximum and minimum limits can be determined by reference to the time current characteristic curves, **Figure 7**.

1. Connect the green plug to terminal 1 and the white plug to terminal 9, the black banana plug to 7 and the red to 8. Connect the black pin plug to TP-1 and the yellow (TP-3) to TP-3.
2. Set LONG TIME PICK-UP on "A," LONG TIME BAND on 1, SHORT TIME and INSTANTANEOUS PICK UPS fully counterclockwise and SHORT TIME BAND on MAXIMUM.
3. Press the START button and adjust the current to 3 amperes (6X "A" pick-up).
4. In turn, press the STOP and the RESET buttons. Allow time for the ammeter reading to reach zero.
5. Press the START button. (It is not necessary to hold this button. Power will be maintained until the Static Trip times out.)
6. When the trip device operator, check the reading of the stop clock against the curves in **Figure 7**. The reading should be approximately the same as shown on the faceplate of the device, but must be within the limits shown on the curves. If not, recheck all settings and repeat the test.
7. Repeat steps 5 and 6 one or more times to verify the test results.

8. Repeat for the other phases (by changing green plug to terminal 2 for phase 2, and terminal 3 for phase 3) time delay bands and other values of current, as desired. All test points should fall within the bands of **Figure 7**. Each time band should have precisely twice the delay of the next lower band when all other conditions are the same.

NOTE

When timing at values of current only slightly above pick-up, line voltage fluctuations may cause detripping and result in erroneous operating times. Therefore, it is advisable to watch the long time pick-up light to note whether trigger voltage is maintained. In general, it is impractical to test time delay at less than 10% above pick-up.

Short Time Delay Test

1. Connect the green plug to terminal 1, the white plug to terminal 9, the red plug to 8 and the black to 7. The pin plugs are not needed.
2. Set LONG TIME PICK-UP on "A," LONG TIME BAND on 6, INSTANTANEOUS PICK-UP fully counterclockwise, SHORT TIME PICK-UP on 3X (1.5 amperes) and SHORT TIME BAND on MAXIMUM.
3. Press the START button and adjust the current to 2 amperes or more, then release both buttons. In turn, press the STOP and the RESET buttons.
4. Close the circuit breaker, if desired.
5. Press the START button, the delay should be .35 to .50 seconds. See **Figure 7**.
6. Repeat the SHORT TIME BAND settings of INTERMEDIATE and MINIMUM, compare to **Figure 7**. The other phase circuits and different values of current can be tested if desired. Make current settings as quickly as possible to avoid overheating.

Ground Time Delay Test

1. Connect the green plug to terminal 4, the white plug to terminal 9, the red to terminal 8 and the black to terminal 7. The pin plugs are not needed.
2. Set GROUND PICK-UP on 15% (0.15 ampere) and GROUND TIME BAND on MAXIMUM.

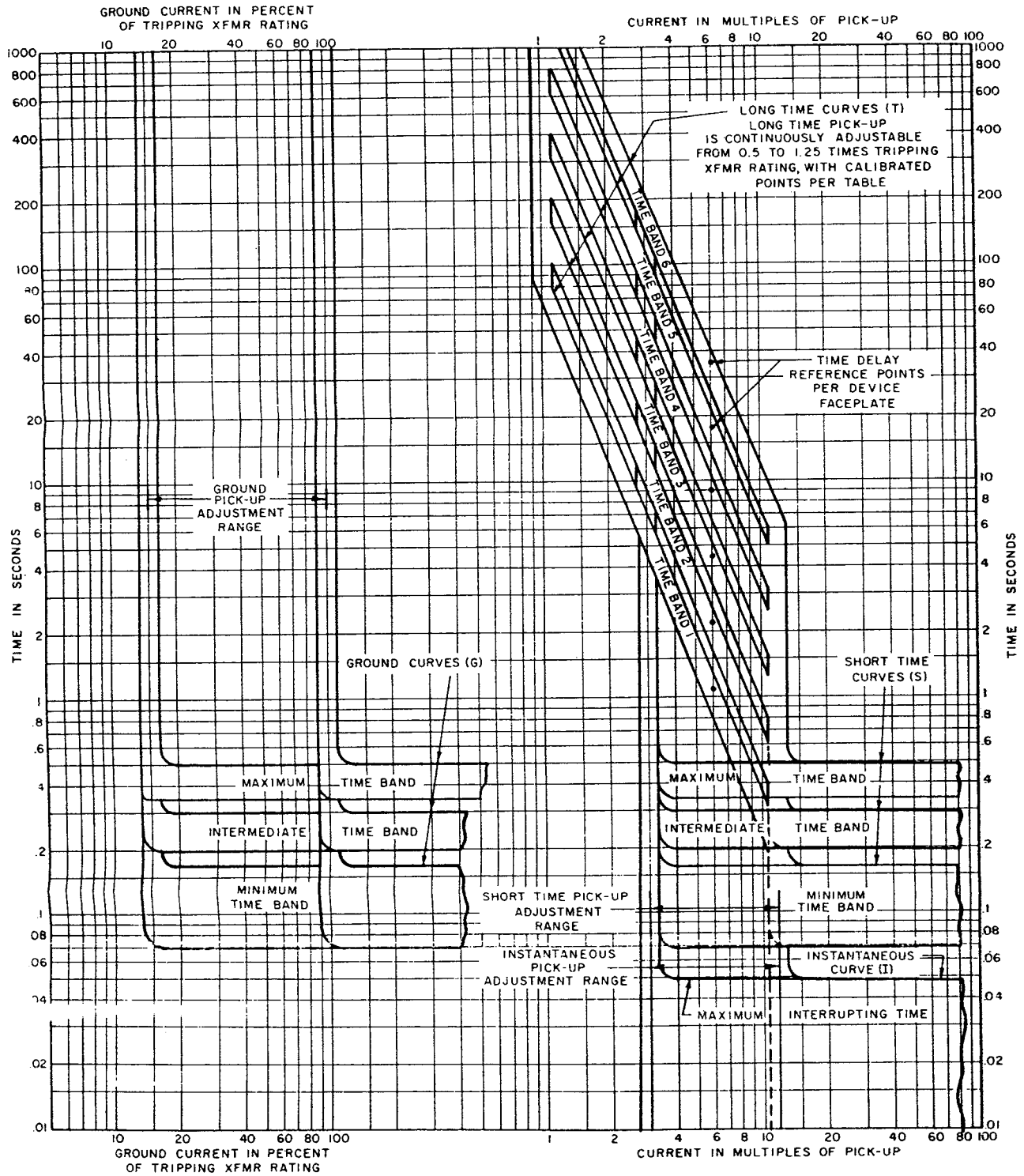

Figure 7. Time Current Curves—Static Trip II

3. Press the START button and adjust the current to 0.5 ampere or more. (Erroneous time delay readings and failure to trip the circuit breaker or target may occur at lower values of current. The waveshape of current from the test set may not provide enough power to charge the filter capacitor in the trip device before tripping occurs. By running the test at a higher current this effect is minimized). In turn press the STOP and the RESET button.
4. Close the circuit breaker, if desired.
5. Press the START button. The breaker should trip in 0.4 and 0.5 seconds. See **Figure 7**. If the device has a target, its red button should pop out.
6. Repeat for other GROUND TIME BAND SETTINGS and for other pick-up and current settings, if desired. Make current adjustments above 1 ampere quickly to avoid overheating.

Bench Testing Static Trip II Devices

Connections

With the static trip device away from the circuit breaker it is necessary to make connections directly to the fanning strip of the trip device. A terminal block is provided on the test set to facilitate this connection. Simply connect the fanning strip to the terminal block and tighten all screws. The end of the fanning strip next to the cord must connect to terminal 1, a spacer under one mounting screw of the test set faceplate provides interference if the connections are made incorrectly.

The terminal block is connected internally, so the cord set is not used.

Test Procedure

The testing procedures are exactly the same as given in "TESTING THE STATIC TRIP ON THE CIRCUIT BREAKER" except, of course, any reference to the circuit breaker is ignored, and the phase selector switch is used to change the test connectors.

Connections—Use Cord Set 18-732-184-506

Phase Selector Switch on phase 1, for all tests.

The connections to the first generation trip devices terminate on an 8 or 9 point terminal block mounted on the side of the device. See **Figure 8**. To allow using the test set plugs to connect to this terminal block, alligator clips are furnished with the test set to clip onto the terminal block screws. Four of the clips accept the four banana plugs and three accept the pin plugs for the pick-up lights. The bottom line of **Table 3** gives the calibrated settings for secondary amperes for the first generation trip devices and on the same page, available models are listed and described. **Figures 13, 14, 15, 16** and **17** are the time current characteristic curves for the various models. Connections from the test set are different for different models and are shown in **Figures 9 through 12**.

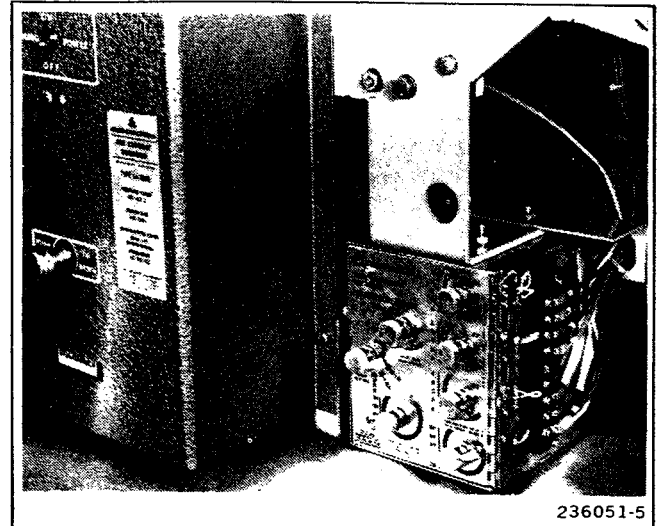

Figure 8. First Generation Static Trip Terminal Block

It will be helpful to note certain differences between these static trips and STATIC TRIP II devices: (1) there are three Long Time Pick-Up knobs, one for each phase, instead of one common knob as on STATIC TRIP II (2). There are only three Long Time Bands instead of 6 and they are marked "Maximum," "In-

termediate," and "Minimum." On some models, no long time band adjustment is available and the device is marked to show which time band it contains. (3) The Instantaneous Pick-Up is

Table 3

Breaker Type	Models A3, AG2, 4WAG, D2, DG1, 4WDG					Tripping Transformer Group No.	Models AG2 and DG1				Models 4WAG and 4WDG			
	Long Time Delay Elements Available Pick-Up Settings (Amperes)						Long Time Delay Element Available Ground Fault Settings (Amperes)				Inst. or Short Time Delay Available Ground Fault Settings (Amperes)			
							Percent of "A" Pick-Up				Percent of "A" Pick-Up			
	A	B	C	D	E		20%	40%	60%	80%	20%	40%	60%	80%
LA-600	40	50	60	70	80	I	—	—	—	—	—	—	—	—
LA-600	75	95	110	130	150	II	—	—	—	—	—	30	45	60
LA-600 LA-1600	125	155	175	220	250	III	—	—	—	—	25	50	75	100
LA-600 LA-1600	200	250	300	350	400	IV	40	80	120	160	40	80	120	160
LA-600 LA-1600	300	375	450	525	600	V	60	120	180	240	60	120	180	240
LA-600 LA-1600	400	500	600	700	800	V-x	80	160	240	320	80	160	240	320
LA-1600	500	625	750	875	1000	VI	100	200	300	400	100	200	300	400
LA-1600	800	1000	1200	1400	1600	VII	160	320	480	640	160	320	480	640
LA-1600	1000	1250	1500	1750	2000	VII-x	200	400	600	800	200	400	600	800
LA-3000	1200	1500	1800	2100	2400	VIII	240	480	720	960	240	480	720	960
LA-3000 LA-4000	2000	2500	3000			IX	400	800	1200	1600	400	800	1200	1600
LA-3000	2000	2500	3000	3500*	4000*	IX-x	400	800	1200	1600	400	800	1200	1600
LA-4000	2000	2500	3000	3500	4000	X	400	800	1200	1600	400	800	1200	1600
Secondary Pick-Up Current-Amperes	0.50	0.625	0.75	0.875	1.00	—	0.10	0.20	0.30	0.40	0.10	0.20	0.30	0.40

*Maximum continuous current for LA-600 is 600A, LA-1600 is 1600A, LA-3000 is 3000A, and LA-4000 is 4000A.

labeled "Instantaneous Trip Setting" (4). The Short Time Pick-Up is labeled "Transfer to Short Time (5). There are no test jacks provided on the front of the device. Connections for trigger indication are made to points on the terminal block as shown in **Figures 9 through 12.** (6) On STATIC TRIP II the knob reference dots (knob counterclockwise against stop) are black and the calibration dots are red. On first generation trip devices the reference dots are red and the calibration dots are black on some models and white on others.

NOTE

Once pickup has been verified, disconnect the indicators for Time Delay Testing. The indicators can load the circuit and prevent the trip device from timing out.

Test Procedures

Keeping the above differences in mind and making careful reference to the appropriate connection diagram in **Figure 9 through 12,** the test instructions in "Testing Static Trip on the Breaker" (omitting the connection instructions in each case), can be used for testing first generation trip devices also. Compare the test results with **Table 3** and **Figures 13, 14, 15, 16** and **17** as applicable.

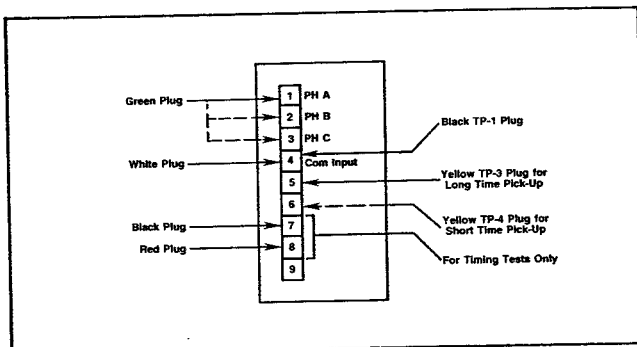

Figure 9. Test Connections—Models A, A1, A2, C3, D, D1 and D2

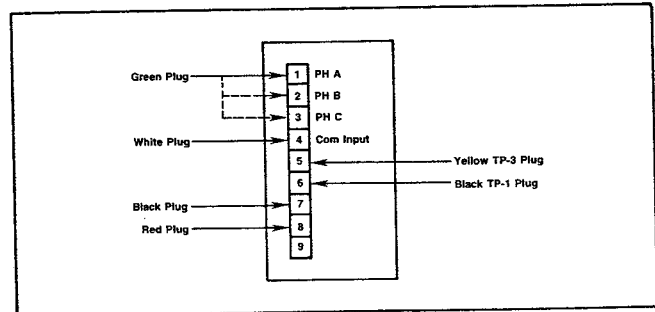

Figure 10. Test Connections—Models AG, AG1, AG2, DG and DG1

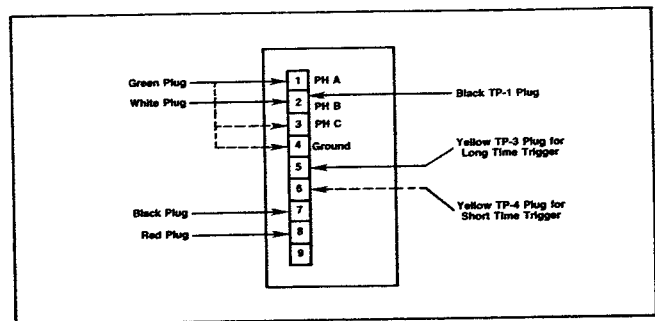

Figure 11. Test Connections—Models 4WAG and 4WDG

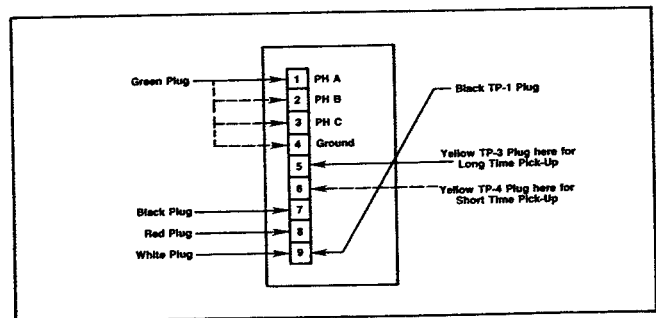

Figure 12. Test Connections—Models C, C1 and C2

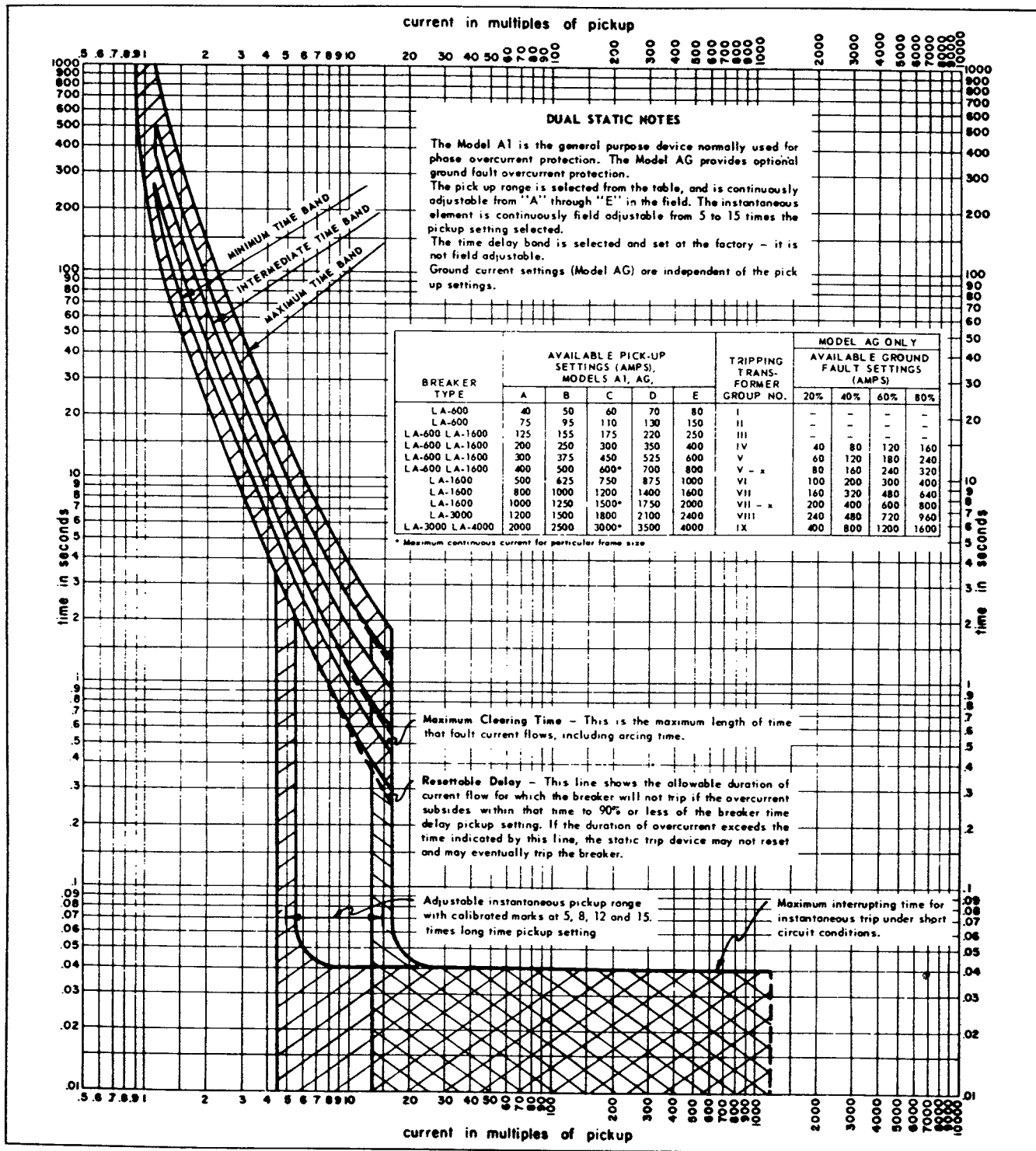

Figure 13. Time Current Curves—Models A, A1, A2, AG and AG1

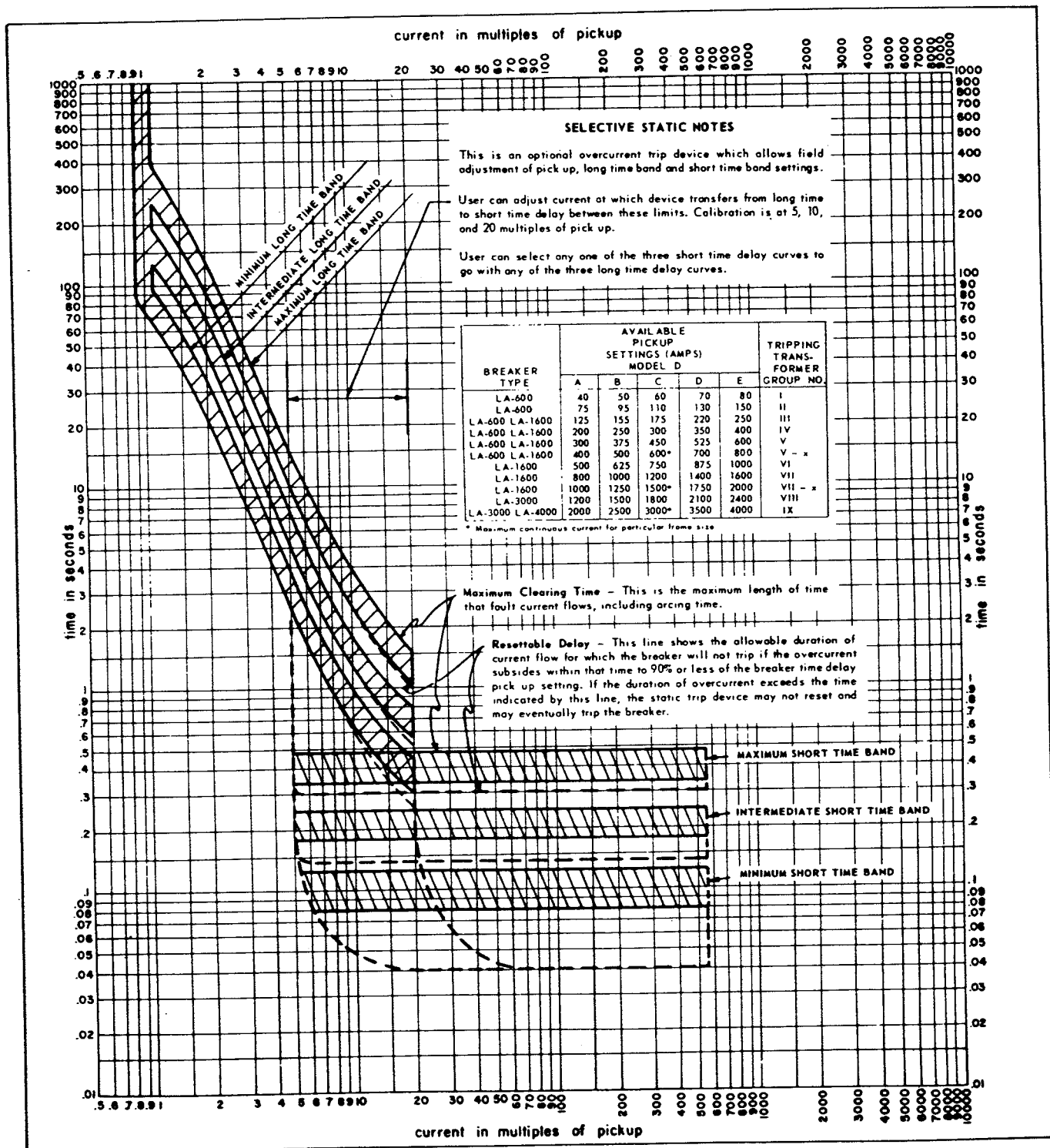

Figure 14. Time Current Curves—Models D and D1

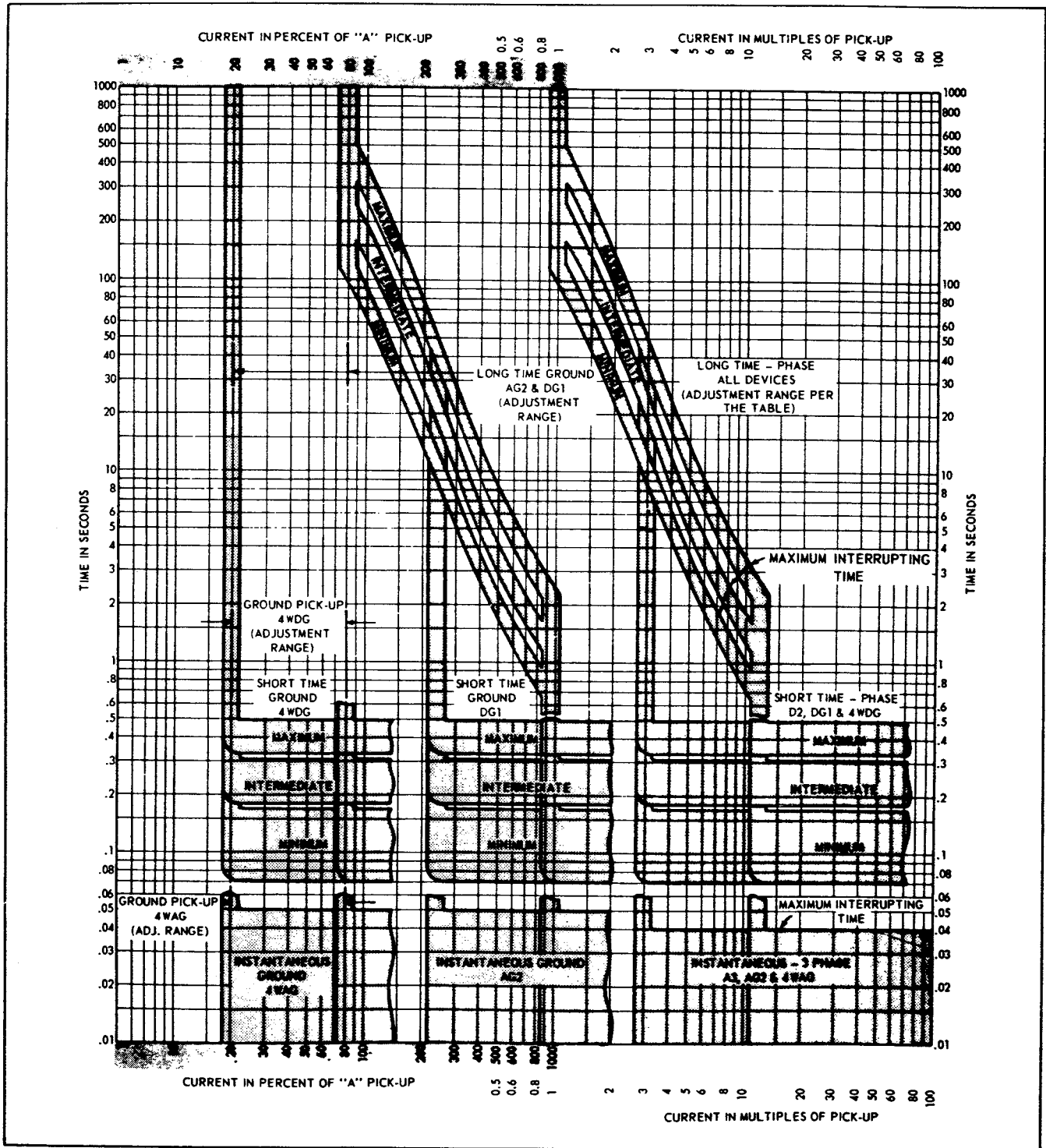

Figure 15. Time Current Curves—Models A2, A3, D2, DG1, 4WAG and 4WDG

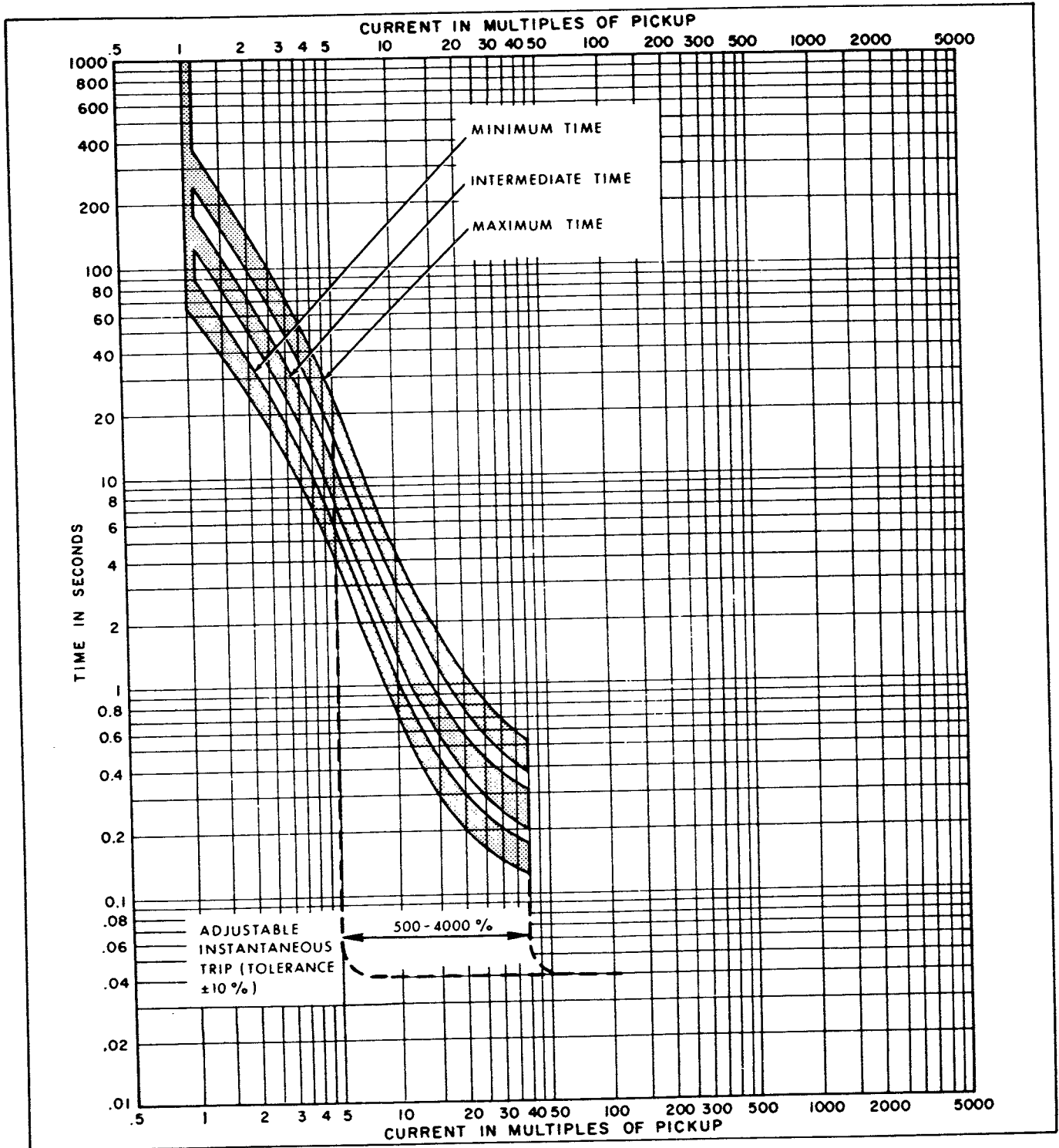

Figure 16. Time Current Curves—Models C, C1 and C2

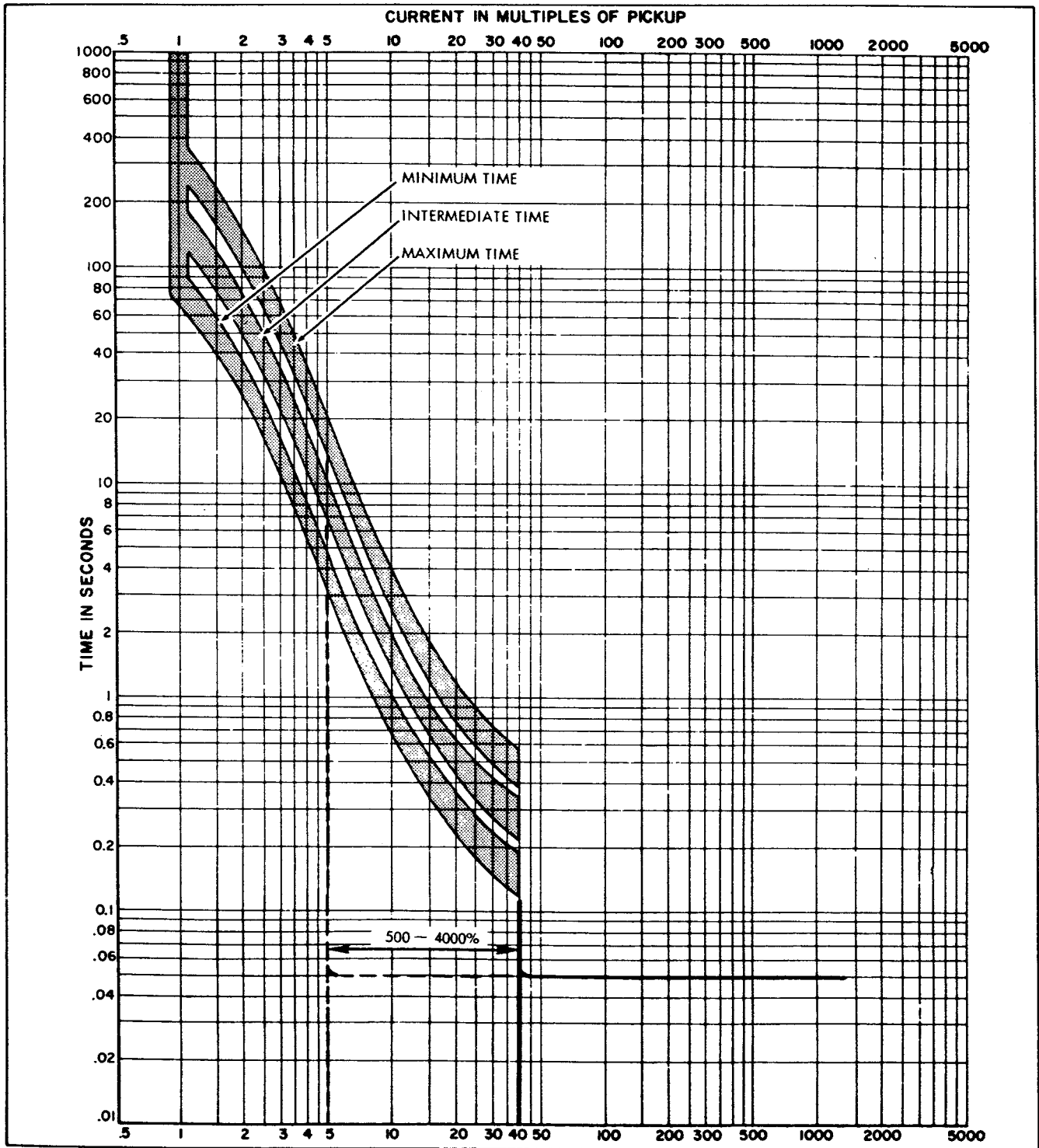

Figure 17. Time Current Curves—Model C3

Bench Testing

The alligator clips described previously are also used to make connections to the first generation trip devices for bench testing, so connections and procedures are the same as when testing with the device on the circuit breaker.

1. Types

- A — Dual Static (long time and instantaneous elements).
- C — Dual Static Selectable Time Band and high range instantaneous.
- D — Selective Static (long time and short time elements)
- AG — Dual Static with ground fault element for 3 wire circuits.
- DG — Selective Static with ground fault element for 3 wire circuits.
- 4WAG — Dual Static with ground fault element for 4 wire and 3 wire circuits.
- 4WDG — Selective Static with ground fault element for 4 wire and 3 wire circuits.

2. The pick-up settings of the instantaneous and short time delay elements are calibrated at 3, 5, 8 and 12 multiples of the long time delay pick-up setting.
3. The maximum interrupting time is the maximum length of time that fault current flows, including arcing time.
4. Instantaneous maximum interrupting time may be greater when breakers are closed in on a fault depending on actual fault conditions. The maximum potential increase for a 3 phase fault is 0.01 seconds and for a single phase ground fault is 0.02 seconds.
5. The lower limit of ground fault recognition is 25 amperes for an LA-600 breaker. For an LA-1600 breaker the lower limit is 40 amperes. Application of Models 4WAG and 4WDG is not recommended for LA-600 breakers having a minimum continuous current setting of less than 75 amperes or an LA-1600 breaker with a minimum continuous current setting of less than 200 amperes.

Dual Device

MODEL A — general purpose device normally used for phase overcurrent protection. The pick-up range is selected from the

trip rating table and is continuously adjustable from "A" through "E" in the field. The instantaneous element is continuously field adjustable from 3 to 12 multiples of the long time delay pick-up settings selected. The time delay band is selected and set at the factory—it is not field adjustable. Available time delays are minimum, intermediate and maximum.

MODEL AG (optional) — provides phase overcurrent protection plus sensitive ground fault overcurrent protection for systems with phase-to-phase loading. Ground current pick-up settings are independent of the phase pick-up settings, and continuously adjustable in the field from 20% through 80% of the minimum phase pick-up setting shown in column "A."

MODEL 4WAG (optional) — provides phase overcurrent protection plus sensitive ground fault overcurrent protection for 3 wire and 4 wire circuits for systems with phase-to-neutral loading. Ground current pick-up settings are independent of the phase pick-up settings, and continuously adjustable in the field from 20% through 80% of the minimum phase pick-up setting in column "A."

MODEL C (optional) — Dual Static Selectable Time Band and high range instantaneous.

MODEL D (optional) — an overcurrent trip device which provides time delay tripping only. It allows field adjustment of long time delay and pick-up and short time delay and pick-up. The continuous adjustment feature allows a setting selection anywhere within calibrated points. The user can adjust the current at which the device transfers from long time to short time delay between these limits. Any one of the three short time delay curves can be chosen to be used with any of the three long time delay curves.

MODEL DG (optional) — provides phase overcurrent protection plus sensitive ground fault overcurrent protection for systems with phase-to-phase loading. Ground current pick-up settings are independent of the phase pick-up settings, and continuously adjustable in the field from 20% through 80% of the minimum phase pick-up setting shown in column "A."

MODEL 4WDG (optional) — provides phase overcurrent protection plus sensitive ground fault overcurrent protection for 3 wire and 4 wire circuits for systems with phase-to-neutral loading. Ground current pick-up settings are independent of the phase pick-up settings, and continuously adjustable in the field from 20% through 80% of the minimum phase pick-up setting in column "A."

It will be helpful to note certain differences between Limitrip and Static Trip II devices: (1) In the Limitrip system, the power supply and signal transformers are relocated to and combined in the "Sensor Transformers" mounted on the rear of the breaker. There are two cores in each Sensor Transformer. One core provides power to the trip device and the other provides the input signal. The PTS-4 test set is arranged to provide both an input signal and power signal for test purposes. Static Trip II device contains both power signal transformers. (2) All adjustments are made with switches in place of potentiometer type controls. (3) Only six long time pick-up settings are provided compared with seven settings for Static Trip II. (4) Only four long time delay bands are included compared with six for Static Trip II the shortest and the longest bands are omitted on Limitrip. (5) The ground fault tripping option is not available. (6) Instantaneous and short time pick-up settings are switch selectable at 3X, 6X, 8X and 12X as compared to continuously adjustable settings with calibrated points of 3X, 5X, 8X and 12X for Static Trip II. (7) Time current curves are in multiples of pick-up setting rather than in multiples of pick-up current.

General

1. The "Tripping XFMR Rating" values represent the primary value of the sensor transformer in amperes. The secondary value is one ampere.
2. The pick-up settings of the long time element are switch selectable at calibrated points "A" thru "F" as shown in the rating table.
3. The pick-up settings of the instantaneous and short time delay elements are switch selectable at 3, 6, 8 and 12 multiples of the long time pick-up setting.
4. The long time element has 4 bands that are switch selectable. The time delay at 4 multiples of pick-up is as follows:
Band 1—2.25 Seconds Band 3—9 Seconds
Band 2—4.5 Seconds Band 4—18 Seconds
5. The short time element has 3 time delay bands which are switch selectable (minimum, intermediate and maximum).
6. The maximum interrupting time is the maximum length of time that fault current flows, including arcing time.
7. Instantaneous maximum interrupting time may be greater when breakers are closed in on a fault depending on ac-

tual fault conditions. The maximum potential increase for a 3 phase fault is 0.01 seconds and for a single phase ground fault is 0.02 seconds.

Connections—Use Cord Set 18-732-184-507

The connections for the Limitrip trip devices are made with an integral wiring harness that terminates directly on the Sensor transformers on the back of the circuit breaker. To gain access to these terminals, it is necessary to remove the circuit breaker from the cubicle.

The trip device output leads are connected to the tripping actuator by quick disconnect "couplers." To connect the test set output leads, the couplers are disconnected and jack assemblies 18-732-085-501 and 502 are inserted into each of the lines to the actuator. The test set leads are then plugged into the jack assemblies.

The trigger test points are not brought out on the Limitrip device, so the pick-up cord set is provided with "Grabbers" to connect directly to the circuit board inside the device. See **Figure 18** for the correct location of the test points. Connect the red "Grabber" to the long time pick-up test point and the black "Grabber" to the pick-up common test point. The red banana plug of the cord set connects to the jack assembly on the red leads of the trip device and the black banana plug to the jack assembly on the black leads of the device.

The connections to the sensor terminals at the rear of the circuit breaker are made as shown in **Figure 19**. To test A phase, make the following cord set banana plug connections at the terminals of the A phase Sensor Transformer: Blue banana plug into terminal B (power lead), Green banana plug into terminal G (power lead), Yellow banana plug into terminal Y (signal lead), and the Orange banana plug into terminal O (signal lead). To test the other phases, move all four banana plugs to the Sensor terminals of the phase being tested. Note, on Sensor transformers rated 2000 amperes and up, it is necessary to disconnect either the blue or green the lead from the transformer and connect the test set directly to the Limitrip device because the low impedance of the power winding may prevent tripping.

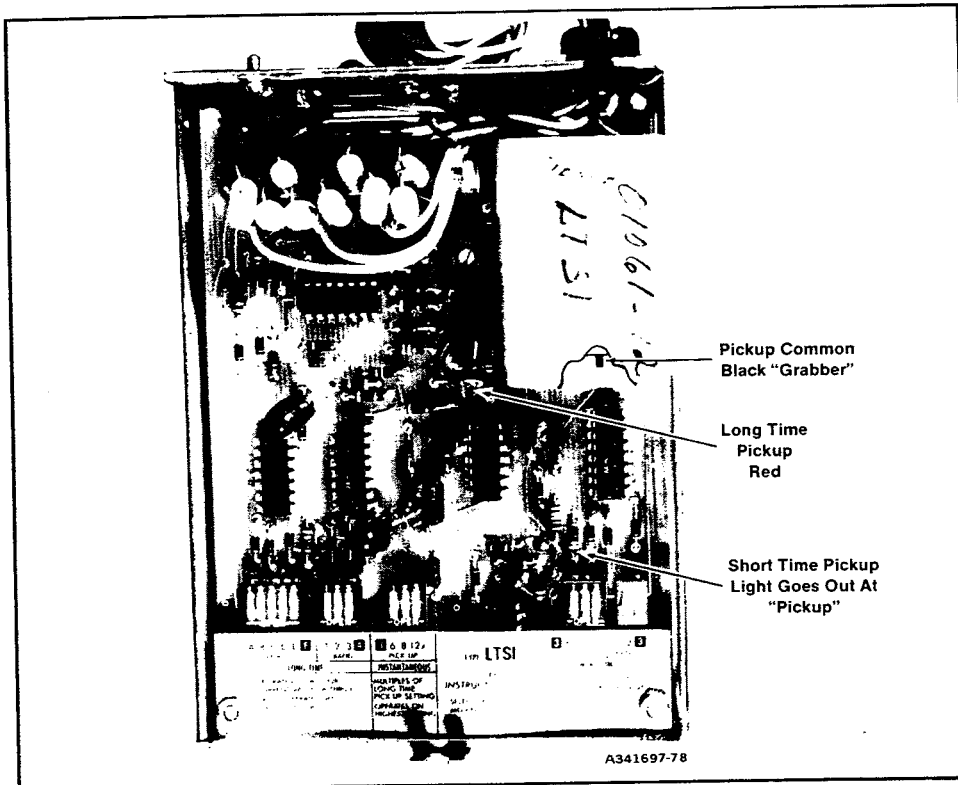

Figure 18. Limitrip Circuit Board Showing Test Points

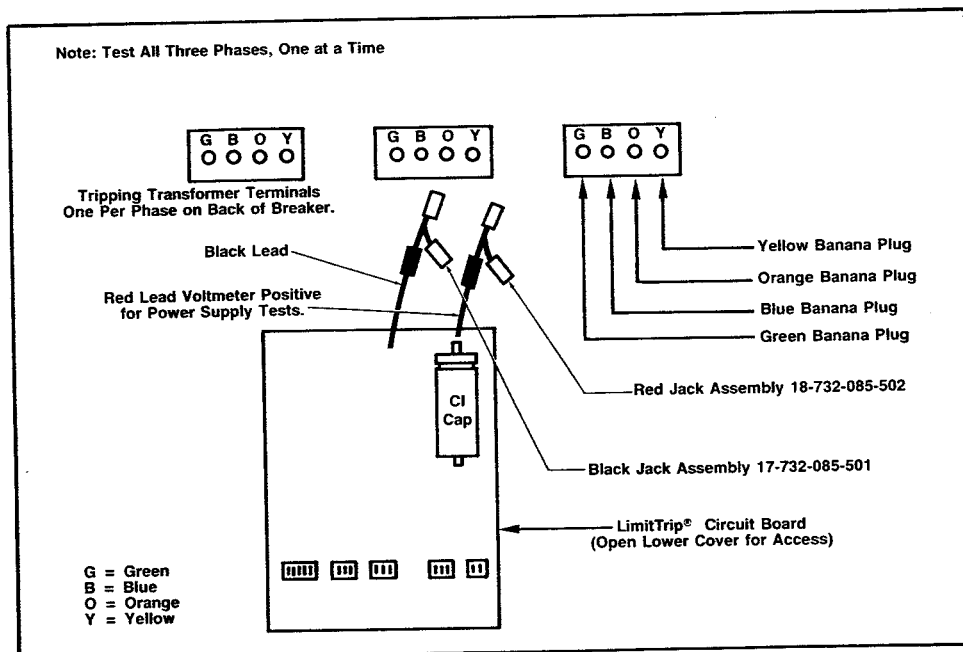

Figure 19. Limitrip Test Connections

Settings of Bands and Pick-Ups

PICK-UP and BAND settings are made by closing or opening switches grouped in DIP switch modules for the various functions. A switch is closed when it is removed up, depressing the end opposite the word open.

The PICK-UP or BAND setting is determined by the closed switch, in each DIP switch module, FARTHEST AWAY from the black highlighted number of letter. The setting of the function controlled by a module is not affected by the position (open or closed) of other switches in that module closer to the black highlighted number or letter than the desired setting. Where the black highlighted number is the largest number or letter, the setting is controlled by the LOWEST closed switch (LONG TIME PICK-UP, LONG TIME BAND, and SHORT TIME PICK-UP). Where the black highlighted number is the smallest number, the setting is controlled by the HIGHEST closed switch (INSTANTANEOUS PICK-UP and SHORT TIME BAND). The device label adjacent to each switch indicates the setting for that function if it is the farthest closed switch. For example, if LONG TIME PICK-UP module switch 3 is the farthest closed switch from the black highlighted "F," the device is set at "C" setting of LONG TIME PICK-UP. If the switches on a module are all open, the setting will be that indicated by the black highlighted number.

Use peak responding "All Other Test," for all Limitrip testing.

Test—Long Time Pick-Up

It is not necessary to operate the circuit breaker during the trip device tests, the breaker can be left open.

1. Make all connections as described in the preceding section, CONNECTIONS.
2. Set LONG TIME PICK-UP on "A" by closing (depressing) the numbered end of the LONG TIME PICK-UP switch labeled A in the Limitrip. Place the trip device test set selector switch to STATIC TRIP TEST position. Set the range switch on LOW. Set the POWER selector switch to INTERNAL.
3. Turn the test set ON. The red digits of the meters should come ON, (the alarm light may turn ON also, press the STOP—alarm reset button). Press and hold the START and RESET push buttons.
4. Slowly increase the current by rotating the INTERNAL POWER CONTROL in a clockwise direction. Increase the current until the LONG TIME PICK-UP light comes ON; this should be at 0.5 ampere \pm 10%. The sampling rate of the digital ammeter is such that the control must be moved very slowly to accurately determine the pick-up current of the trip device.
5. Decreasing the current slightly should cause the light to go OUT.
6. Repeat the tests for the other phases and settings and compare with **Table 4**.

Table 4
Limitrip Rating Table—Amperes

Breaker Type and Frame Size	Tripping XFMR Rating (Primary)	Long Time Element Calibrated Pick-Up Settings						Max. Cont. Rating
		A	B	C	D	E	F	
LA600 600 Amperes	80	40	50	60	70	80	90	90
	200	100	125	150	175	200	225	225
	400	200	250	300	350	400	450	450
	600	300	375	450	525	600	675*	600
LA1600 1600 Amperes	200	100	125	150	175	200	225	225
	400	200	250	300	350	400	450	450
	800	400	500	600	700	800	900	900
	1600	800	1000	1200	1400	1600	1800*	1600
LA3000 3000 Amperes	2000	1000	1250	1500	1750	2000	2250	2250
	3000	1600	2000	2400	2800	3200	3600*	3000
LA4000 4000 Amperes	4000	2000	2500	3000	3500	4000	4500*	4000

*Do not exceed the maximum continuous current rating of the circuit breaker.

Test—Short Time Pick-Up

1. Connect the Red GRABBER to the SHORT TIME PICK-UP test point. See **Figure 18**.
2. Set LONG TIME PICK-UP on "A," INSTANTANEOUS PICK-UP on "12X" (Close the 12X switch). Set SHORT TIME PICK-UP on 3X (open all switches).
3. Press and hold the START and RESET buttons.
4. Slowly increase the current until the LONG TIME PICK-UP light goes OUT. This should occur at 1.5 amperes \pm 10%.

NOTE

Moving the red grabber connects the Long Time Pick-Up test leads to the Short Time test point, and this signal goes to zero at pick-up.

5. Repeat for SHORT TIME PICK-UP settings of 6X, 8X and 12X. The RANGE switch must be on HIGH for these tests. To avoid over heating, do not maintain the higher currents any longer than necessary.

Test—Instantaneous Pick-Up

A trigger test point for INSTANTANEOUS TRIP is not available. Tripping of the circuit breaker and/or operation of the test set relay will indicate instantaneous trip operation. To operate the test set relay, the red and black banana plugs must be connected to the trip device output using the jack assemblies.

1. Connect the test set to the circuit breaker as described in the section under the heading CONNECTIONS.
2. Set LONG TIME PICK-UP on "A," LONG TIME BAND on 4 (all switches open), SHORT TIME PICK-UP on 12X switch). Set INSTANTANEOUS on 3X (open all switches).
3. Raise the current slowly until the relay in the test set operates. This can be determined audibly and should occur at 1.5 amperes \pm 10%.
4. Repeat for the other settings as desired. Avoid maintaining high currents longer than necessary to obtain the readings.

5. If it is desired to test the operation of the circuit breaker, any of the above tests can be run with the circuit breaker closed, allowing the trip device to open the circuit breaker when it operates. It may be desirable to disconnect either the red or black banana plug from the jack assembly to assure that the relay in the test set does not interrupt the current before the circuit breaker can open thus confusing the test results.

Test—Long Time Delay

1. Connect the test set to the device as described under the heading "Connections." Connect the red GRABBER to the LONG TIME TEST POINT shown in **Figure 18**.
2. Set LONG TIME PICK-UP on "A" LONG TIME BAND on 1, SHORT TIME PICK-UP and INSTANTANEOUS on 12X.
3. Press the START button and adjust the current to 3 amperes (6 times "A" pick-up).
4. In turn press the STOP and the RESET buttons. Allow time for the ammeter to return to zero.
5. Press the START button. It is not necessary to hold this button. Power will be maintained until the trip device times out.
6. When the trip device operates, check the reading of the stop clock against the curves shown in **Figure 19**. The reading should be within the limits shown on the curve.
7. Repeat steps 4, 5 and 6 several times to verify the results.
8. Repeat for the other phases, time delay bands and other values of current, as desired. All test points should fall within the bands shown on **Figure 19**. Each band should have precisely twice the delay of the next lower band when all other conditions are the same.

NOTE

When timing at values of current only slightly above pick-up line voltage fluctuations may cause detripping and result in erroneous operating times. Therefore, it is advisable to watch the long time pick-up light to note whether the trigger voltage is maintained or not. In general, it is impractical to test at less than 10% above pick-up.

Test—Short Time Delay

1. Connections to the device as described under the heading "Connections." The GRABBER connections are not needed.
2. Set LONG TIME PICK-UP on "A," LONG TIME BAND on 4 (all switches open), INSTANTANEOUS on "12X," SHORT TIME PICK-UP on "3X," and SHORT TIME BAND on 1 (Minimum setting, both switches closed).
3. Press the START button and adjust the current on 2 amperes or more and then release buttons. In turn, press the STOP and RESET buttons.
4. Close the circuit breaker, if desired.
5. Press the START button, the delay on the stop clock should be 0.07 to 0.170 seconds. See **Figure 20**.
6. Repeat for SHORT TIME BANDS of INTERMEDIATE (Band 3). Compare with **Figure 20**. The other phases and dif-

ferent values of current can be tested if desired. Make current settings as quickly as possible to avoid overheating.

Bench Test—Limitrip Devices

To bench test Limitrip devices, follow the same procedures previously indicated for testing on the breaker. The following adjustments in procedure and comments should be noted: (1) The alligator clips are used to connect the test set-cord-set leads to the Limitrip device for bench testing. (2) Since the wiring harness is attached to the trip device, the color coding of the leads still match the color of the banana plug. (3) The signal circuits share a common ORANGE lead. (4) Connections can be made using any lead of the color coded groups. Again, each signal (Orange-Yellow) and all three pair of power leads (Blue-Green) must be checked.

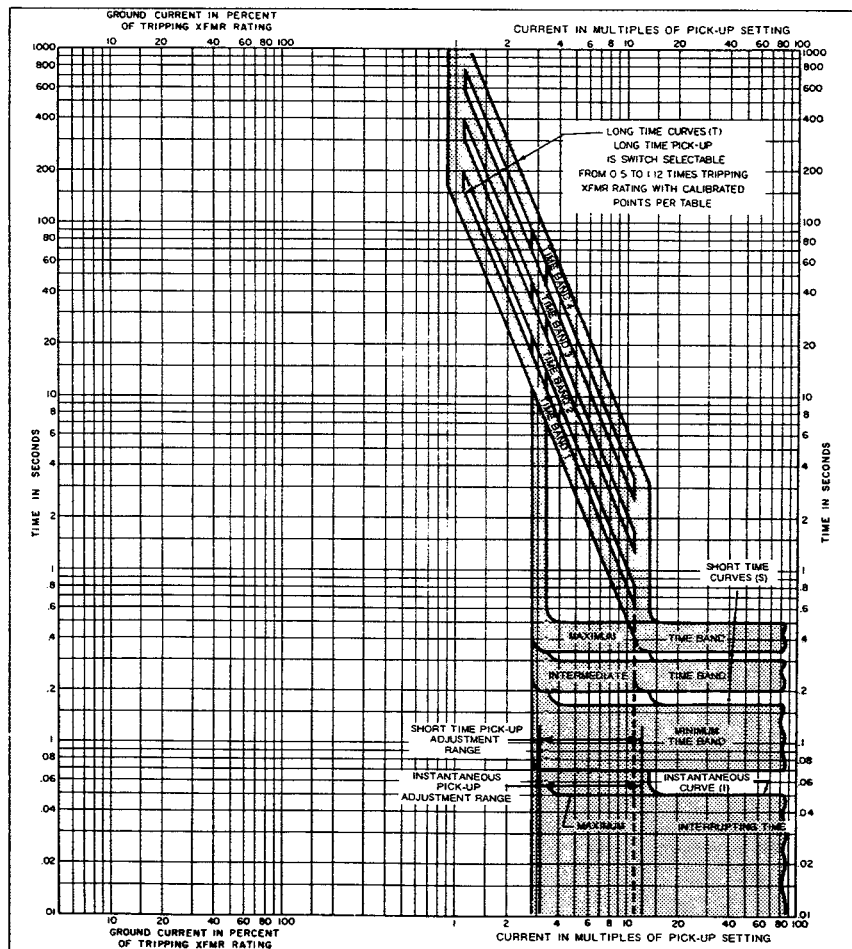

Figure 20. Limitrip Time Current Curves

There are several things that can throw test results off so if results don't agree with design values, it is best to verify that equipment and testing procedures are in order before drawing any conclusions.

1. Recheck test connections to make sure that they are correct.
2. Verify device settings and knob calibration. See Section "Restoring Lost Calibration."
3. Return the knob to the previous setting making sure that the pointer lines up accurately with the correct calibration dot (see Section "Static Trip Calibration Marks" and repeat the test.
4. If there seems to be error in the same direction for all settings, the ammeter may be at fault. To check the test set ammeter, connect an ammeter that is known to be accurate to terminals 1 and 9 of the seven pin terminal block select phase 1. Connect an external Variac to the test set external input terminals and set the input power selector switch to EXTERNAL. Check the ammeter at several values of current on both the high and low ranges. The two ammeters should agree within approximately 3% of full scale for all readings.
5. If pick-up settings meet design tolerance and the time delays do not, the stop clock may be a fault. This can be checked against a stop watch. The tolerance should be within 5 seconds in 5 minutes (300 seconds).
6. As pointed out in the introduction, line voltage fluctuations may cause timing errors. Watch the ammeter during the timing intervals and adjust the current control as necessary to hold the current constant.
7. Electrical noise may interfere with the internal phase control circuitry and can make testing difficult if not impossible in some cases. An external Variac (Variable transformer) can be used as a source for the test set by-passing the phase control elements. This connection may overcome some testing difficulties.

If the device fails to trip the circuit breaker, the trouble may be in the tripping actuator.

Testing the Actuator on the Circuit Breaker

1. Place the selector switch in the "Actuator Test" position. This energizes the red and black five-way binding posts.
2. Use the voltmeter lead 18-732-184-503 to connect the five-way binding posts to the actuator leads on the circuit breaker. These connect to the static trip terminals 7 and 8 on circuit breakers with STATIC TRIP II or first generation static trip devices. These leads are connected with "Faston Couplers" when Limitrip devices are supplied; the red post connects to the red wire on the actuator (terminal 8), the black post connects to the black actuator wire (terminal 7). If the static trip is not disconnected, do not exceed 12 volts DC input while testing the actuator.
3. Close the circuit breaker.
4. Slowly increase the voltage from the internal supply with the "Power Control" knob. Note the voltage at which the circuit breaker trips. This should be somewhere between 4.5 and 10 volts.
5. Rotate "Power Control" knob counterclockwise to remove power.
6. Failure of the circuit breaker to trip at any voltage even up to 12 volts may be due to the actuator plunger binding. This can be checked manually. **USE EXTREME CAUTION WHEN WORKING ON THE CIRCUIT BREAKER. THE ENERGY STORED IN THE CLOSING AND/OR OPENING SPRINGS MUST BE RESPECTED. ALWAYS DISCHARGE ALL SPRINGS BEFORE PLACING HANDS NEAR THE MECHANISM.** See the circuit breaker instruction book if any problem is evident in the mechanical portion.

7. Measure the actuator coil resistance. This measurement should be made with the static trip disconnected from the actuator. There are three types of actuators of the "sealed" type. One has a resistance of 25 to 30 ohms and should trip between 4.5 and 6 volts maximum. The second type has a resistance of 30 to 40 ohms and its tripping voltage should be between 4.5 and 10 volts. The third type has three coil leads, from red to black has a resistance of 15 to 20 ohms and trips at 3 to 5 volts. The resistance from black to blue is 40 to 50 ohm and trips at 13-20 volts with positive on the blue lead.

Bench Testing Actuators

1. Set the selector switch to the "Actuator Test" position.
2. Connect the red actuator lead to the red five-way binding post and the black actuator lead to the black five-way binding post.
3. Manually reset the actuator plunger by pushing the rod all the way in. Keep the actuator away from any steel during the test since the steel will change the magnetic circuit of the device.
4. Slowly increase the voltage from the internal supply with the "Power Control" knob. Note the voltage at which the circuit breaker trips.
5. Rotate "Power Control" knob counterclockwise to remove power.
6. Check the actuator coil resistance and determine if the tripping voltage satisfies the applicable maximum value as stated in step 7 of the preceding section.

The tests described in the preceding sections verify performance of the static trip device and the actuator.

The third link in the protection system is the circuit breaker mounted tripping transformers. When secondary current testing is done on the circuit breaker, the tripping transformers are subjected to approximately their normal excitation so that a transformer with shorted turns would show up in the form of pick-up and/or time delay values above tolerance. However, an open circuit in the transformer would not show up at all. Therefore, it is desirable to test the tripping transformers as described in the following.

Test Preparations

If the static trip device is on the circuit breaker, disconnect or remove it. For STATIC TRIP II or III, disconnect by removing the fanning strip from the terminal block. For first generation static trips, remove the wiring from the terminal block on the side of the trip device. For a circuit breaker with a Limitrip device, disconnect at the sensor terminals.

Breakers that are wired for four wire ground fault protection have a tripping transformer external to the circuit breaker, either on the neutral or the ground strap. This external transformer is wired to the circuit breaker through secondary disconnect fingers. To test this transformer the circuit breaker must be in the cubicle, in the "TEST" position. If in doubt, refer to the circuit breaker wiring diagram. There are two tests that can be made, winding continuity and exciting current.

Continuity Test

Except where the transformers exhibit evidence of overheating or other damage, a simple continuity test of the wiring and the transformer winding may be all that is required. For transformers rated 1000/1 and above, an exciting current test can be inconclusive due to the low level of current involved and in the case of some of the windings used with the Limitrip devices, continuity is the only test that can be run due to the very low voltage required.

An ohm meter is most suitable for the continuity test. For STATIC TRIP II, test in turn across terminals 1 to 9, 2 to 9, and 3 to 9 of the trip device terminal block, for phase A, B, and C respectively. For a first generation type device, test between each of the heavy black wires and the common white wire. If the cubicle is wired for four wire ground protection, the remote transformer should be checked also; this is between terminal 4 and 9 for Static Trip II, and between the common white wire and the wire that is connected to terminal 9 on 4WAG and 4WDG trip devices. The circuit breaker should be in the "TEST" position so the terminals are connected to the remote transformer.

For Limitrip the test is made at the sensor transformer and is made between the O and Y (Orange and Yellow) and the B and G (Blue and Green) at each set of terminals.

Exciting Current Test

An exciting current test can be run on the transformer. This is done by applying an AC voltage to the secondary winding and observing the magnetizing current. This test may reveal shorted turns in the windings. **Tables 5, 6, 7 and 8** show the maximum allowable exciting current for the various transformers and sensors used. Note, the "B" and "G" terminals of the Limitrip sensors should not be tested for exciting current; due to the small core used, the readings are meaningless.

Table 5. Static Trip II and First Generation Tripping Transformers

Tripping Transformer Rating	Exciting Voltage RMS	Maximum Exciting Current RMS
80:1	33.5	0.25
150:1	67	0.15
200:1	67	0.15
250:1	67	0.15
400:1	67	0.05
600:1	134	0.05
800:1	134	0.03
1000:1 and up	134	0.02

Table 7. Static Trip II R.L. Style Tripping Transformer

Tripping Transformer Rating	Exciting Voltage RMS	Maximum Exciting Current RMS
80:1	30	0.25
150:1	40	0.15
200:1	45	0.15
250:1	50	0.15
400:1	70	0.05
600:1	100	0.05
800:1	100	0.03
1000:1 and up	134	0.02

Table 6. Limitrip Sensor Transformers "O" to "Y" (Signal) Terminals

Sensor Transformer Ratio	Exciting Voltage RMS	Maximum Exciting Current RMS
80:1	4.6	0.25
200:1	7.0	0.15
400:1	17.0	0.05
600:1	32.0	0.05
800:1	34.0	0.03
1000:1 and up	34.0	0.02

Table 8. Static Trip III Tripping Transformer

Tripping Transformer Rating	Exciting Voltage RMS	Maximum Exciting Current RMS
150:5	33.5	0.25
200:5	50	0.15
300:5	67	0.10
400:5	67	0.10
600:5	67	0.05
800:5	134	0.03

Because of the complexity of the semi-conductor components and circuits and because some of the components are especially selected or matched, we do not recommend field repair of static trip devices. Moreover, component failure usually does not show up as visual damage and locating the defective component or components requires specialized techniques.

Therefore, if the tests described in these instructions indicate that a static trip device or the test set itself is defective, contact your nearest Siemens representative for instructions on returning the unit to the factory or other authorized service facility for repair.

SIEMENS

Siemens Energy
& Automation, Inc.

Switchgear Division
P.O. Box 29503
Raleigh, NC 27626
(919) 365-6660