



OPERATION AND SERVICE MANUAL

MODEL 510L LINECHEK™

LINE LEAKAGE TESTER

WITH IEEE-488 (GPIB) OR RS-232 INTERFACE

SERIAL NUMBER

--	--	--	--	--	--	--

Model 510L

© Associated Research, Inc., 2006
13860 West Laurel Drive
Lake Forest, Illinois, 60045-4546
U.S.A.

Item 37977

Ver 1.19

Printed June 19, 2006

DECLARATION OF CONFORMITY

Manufacturer: Associated Research, Inc.

Address: 13860 W. Laurel Dr.
Lake Forest, IL 60045
USA

Product Name: LINECHEK®

Model Number: 510L

Conforms to the following Standards:

Safety: EN 61010-1: 1993 + A2

EMC: EN 50 082-1: 1992, EN 50 081-1: 1992,
IEC 801-2: 1984, EN 55 022: 1994,
IEC 801-3: 1984, EN 60 555-2: 1987,
IEC 801-4: 1988

Supplementary Information

*The product herewith complies with the requirements of the **Low Voltage Directive 73/23/EEC as amended by 93/68/EEC** and the **EMC Directive 89/336/EEC as amended by 92/31/EEC**.*

The CE marking has been affixed on the device according to article 10 of the EMC Directive 8/336/EEC.

The technical file and other documentation are on file with Associated Research, Inc.

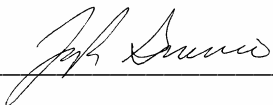

Joseph Guerriero
Vice President / General Manager

Associated Research, Inc.
Lake Forest, Illinois USA
December 21, 1999

Warranty Policies

Associated Research, Inc., certifies that the instrument listed in this manual meets or exceeds published manufacturing specifications. This instrument was calibrated using standards that are traceable to the National Institute of Standards and Technology (NIST).

Your new instrument is warranted to be free from defects in workmanship and material for a period of (1) year from date of shipment. You must complete the on-line registration at www.asresearch.com/register or call 1-800-858-TEST ext. 210 to register over the phone

5-Year Program

AR recommends that your instrument be calibrated on a twelve-month cycle. Instruments purchased and used in North America only, may have their warranty extended in one year increments to a maximum of **(5) years** provided they are returned to AR at least **annually** for calibration and inspection. The annual calibration and inspection must be performed annually every year following receipt of instrument. Any instrument not calibrated and inspected annually will not be eligible for extended warranty status. This extended warranty is non-transferable and is offered only to the original purchaser. A return material authorization (RMA) must be obtained from AR before returning this instrument for warranty service. Please contact our Customer Support Center at 1-800-858-TEST (8378) to obtain an RMA number. It is important that the instrument is packed in its original container for safe transport. If the original container is not available please contact our customer support center for proper instructions on packaging. Damages sustained as a result of improper packaging will not be honored. Transportation costs for the return of the instrument for warranty service must be prepaid by the customer. AR will assume the return freight costs when returning the instrument to the customer. The return method will be at the discretion of Associated Research.

3-Year Program

A 3-Year warranty is also available for instruments purchased and used in North America. All costs for this warranty are paid with the initial purchase and include warranty coverage, annual calibration and standard ground return freight for three years. However, unlike our 5-year program annual calibration and inspection by Associated Research is not required.

Except as provided herein, Associated Research makes no warranties to the purchaser of this instrument and all other warranties, express or implied (including, without limitation, merchantability or fitness for a particular purpose) are hereby excluded, disclaimed and waived.

Any non-authorized modifications, tampering or physical damage will void your warranty. Elimination of any connections in the earth grounding system or bypassing any safety systems will void this warranty. This warranty does not cover batteries or accessories not of Associated Research manufacture. Parts used must be parts that are recommended by AR as an acceptable specified part. Use of non-authorized parts in the repair of this instrument will void the warranty.

TABLE OF CONTENTS

SECTION I OPERATORS MANUAL	1
SAFETY	2
INTRODUCTION	7
SPECIFICATIONS	14
FEATURES AND BENEFITS	16
CONTROLS	17
INSTALLATION	23
QUICK START	25
GENERAL SETUP	28
TEST PARAMETER SETUP	30
SYSTEM SETUP	35
OPERATION	39
DISPLAYED MESSAGES	41
REMOTE CONTROL	43
OPTIONS	53
SECTION II SERVICE MANUAL	55
CALIBRATION	56
PARTS LIST	62
SCHEMATICS	63

SECTION 1
OPERATORS MANUAL

SAFETY PRECAUTIONS REQUIRED FOR HIGH VOLTAGE TESTING!

GENERAL:

This product and its related documentation must be reviewed for familiarization with safety markings and instructions before operation.

This product is a Safety Class I instrument (provided with a protective earth terminal). Before applying power verify that the instrument is set to the correct line voltage (110 or 220) and the correct fuse is installed.

SAFETY SYMBOLS:



INSTRUCTION MANUAL SYMBOL. PLEASE REFER TO THE INSTRUCTION MANUAL FOR SPECIFIC WARNING OR CAUTION INFORMATION TO AVOID PERSONAL INJURY OR DAMAGE TO THE PRODUCT



INDICATES HAZARDOUS VOLTAGES MAY BE PRESENT.

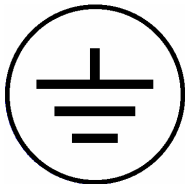

CHASSIS GROUND SYMBOL.



CALLS ATTENTION TO A PROCEDURE, PRACTICE, OR CONDITION, THAT COULD POSSIBLY CAUSE BODILY INJURY OR DEATH.



CALLS ATTENTION TO A PROCEDURE, PRACTICE, OR CONDITION, THAT COULD POSSIBLY CAUSE DAMAGE TO EQUIPMENT OR PERMANENT LOSS OF DATA.

WARNING: A Hipot produces voltages and currents which can cause **harmful or fatal electric shock**. To prevent accidental injury or death, these safety procedures must be strictly observed when handling and using the test instrument.

SERVICE AND MAINTENANCE

User Service

To prevent electric shock do not remove the instrument cover. There are no user serviceable parts inside. Routine maintenance or cleaning of internal parts is not necessary. Any external cleaning should be done with a clean dry or slightly damp cloth. Avoid the use of cleaning agents or chemicals to prevent any foreign liquid from entering the cabinet through ventilation holes or damaging controls and switches, also some chemicals may damage plastic parts or lettering. Schematics, when provided, are for reference only. Any replacement cables and high voltage components should be acquired directly from Associated Research, Inc. Refer servicing to an Associated Research, Inc. authorized service center.

ASSOCIATED RESEARCH, INC.
13860 WEST LAUREL DRIVE
LAKE FOREST, IL 60045-4546 U.S.A.

(PHONE: 1 (847) 367-4077
1 (800) 858-TEST (8378)
FAX: 1 (847) 367-4080
E-MAIL : info@asresearch.com
www.asresearch.com

Service Interval

The instrument and its power cord, test leads, and accessories must be returned at least once a year to an Associated Research authorized service center for calibration and inspection of safety related components. Associated Research will not be held liable for injuries suffered if the instrument is not returned for its annual safety check and maintained properly.

User Modifications

Unauthorized user modifications will void your warranty. Associated Research will not be responsible for any injuries sustained due to unauthorized equipment modifications or use of parts not specified by Associated Research. Instruments returned to Associated Research with unsafe modifications will be returned to their original operating condition at your expense.

TEST STATION

Location

Select an area away from the main stream of activity which employees do not walk through in performing their normal duties. If this is not practical because of production line flow, then the area should be roped off and marked for **HIGH VOLTAGE TESTING**. No employees other than the test operators should be allowed inside.

If benches are placed back-to-back, be especially careful about the use of the bench opposite the test station. Signs should be posted: "**DANGER - HIGH VOLTAGE TEST IN PROGRESS - UNAUTHORIZED PERSONNEL KEEP AWAY.**"

Power

Dielectric Voltage-Withstand Test Equipment must be connected to a good ground. Be certain that the power wiring to the test bench is properly polarized and that the proper low resistance bonding to ground is in place.

Power to the test station should be arranged so that it can be shut off by one prominently marked switch located at the entrance to the test area. In the event of an emergency, anyone can cut off the power before entering the test area to offer assistance.

Work Area

Perform the tests on a nonconducting table or workbench, if possible. If you cannot avoid using a conductive surface, be certain that it is securely grounded to a good earth ground and insulate the high voltage connection from the grounded surface.

There should not be any metal in the work area between the operator and the location where products being tested will be positioned. Any other metal in the work area should be connected to a good ground, never left "floating".

Position the tester so the operator does not have to reach over the product under test to activate or adjust the tester. If the product or component being tested is small, it may be possible to construct guards or an enclosure, made of a non-conducting material such as clear acrylic, such that the item being tested is within the guards or enclosure during the test, and fit them with switches so that the tester will not operate unless the guards are in place or the enclosure closed.

Keep the area clean and uncluttered. All test equipment and test leads not absolutely necessary for the test should be removed from the test bench and put away. It should be clear to both the operator and to any observers which product is being tested, and which ones are waiting to be tested or have already been tested.

Do not perform Hipot tests in a combustible atmosphere or in any area where combustible materials are present.

TEST OPERATOR

Qualifications

This instrument generates voltages and currents which can cause **harmful or fatal electric shock** and must only be operated by a skilled worker trained in its use.

The operator should understand the electrical fundamentals of voltage, current, and resistance. They should recognize that the test instrument is a variable high-voltage power

supply with the return circuit directly connected to earth ground and therefore, current from the high-voltage output will flow through any available ground path.

Safety Procedures

Operators should be thoroughly trained to follow these and all other applicable safety rules and procedures before they begin a test. Defeating any safety system should be treated as a serious offense and should result in severe penalties, such as removal from the Hipot testing job. Allowing unauthorized personnel in the area during a test should also be dealt with as a serious offense.

Dress

Operators should not wear jewelry which could accidentally complete a circuit.

Medical Restrictions

This instrument should not be operated by personnel with heart ailments or devices such as pacemakers.

TEST PROCEDURES

!NEVER PERFORM A HIPOT TEST ON ENERGIZED CIRCUITRY OR EQUIPMENT!

The Line Leakage test and Hipot test should always be performed sequentially and never performed simultaneously. If the instrument has an external safety ground connection be sure that this is connected. Then Connect the return lead **first** for any test regardless of whether the item under test is a sample of insulating material tested with electrodes, a component tested with the high voltage test lead, or a cord-connected device with a two or three prong plug.

Plug in the high voltage test lead only when it is being used. Handle its clip only by the insulator---**never touch the clip directly**. Be certain that the operator has control over any remote test switches connected to the Hipot. Double check the return and high voltage connections from the Hipot and the Line, Neutral, Ground and Case connections from the Line Leakage tester to be certain that they are proper and secure.

WARNING NEVER TOUCH THE ITEM UNDER TEST OR ANYTHING CONNECTED TO IT WHILE HIGH VOLTAGE IS PRESENT DURING THE HIPOT TEST OR LINE VOLTAGE IS PRESENT DURING THE LINE LEAKAGE TEST.

When testing with DC, always discharge the capacitance of the item under test and anything the high voltage may have contacted--such as test fixtures--before handling it or disconnecting the test leads.

HOT STICK probes can be used to discharge any capacitance in the item under test as a further safety precaution. A hot stick is a nonconducting rod about two feet long with a metal probe at the end which is connected to a wire. To discharge the device under test, two hot sticks are required. First connect both probe wires to a good earth ground. Then touch one probe tip to the same place the return lead was connected. While holding the first probe in place, touch the second probe tip to the same place where the high voltage lead was connected.

KEY SAFETY POINTS TO REMEMBER:

- Keep unqualified and unauthorized personnel away from the test area.
- Arrange the test station in a safe and orderly manner.
- Never touch the product or connections during a test.
- In case of any problem, turn off the high voltage first.
- Properly discharge any item tested with DC before touching connections.

GLOSSARY OF TERMS

(as used in this manual)

Alternating Current, AC: Current which reverses direction on a regular basis, commonly in the U.S.A. 60 per second, in other countries 50 times per second.

Breakdown: The failure of insulation to effectively prevent the flow of current, sometimes evidenced by arcing. If voltage is gradually raised, breakdown will begin suddenly at a certain voltage level. Current flow is not directly proportional to voltage. Once breakdown current has flown, especially for a period of time, the next gradual application of voltage will often show breakdown beginning at a lower voltage than initially.

Conductive: Having a volume resistivity of no more than 10^3 ohm-cm or a surface resistivity of no more than 10^5 ohms per square.

Conductor: A solid or liquid material which has the ability to let current pass through it, and which has a volume resistivity of no more than 10^3 ohm-cm.

Current: The movement of electrons through a conductor. Current is measured in amperes, milliamperes, microamperes, nanoamperes, or picoamperes. Symbol = **I**

Dielectric: An insulating material which is positioned between two conductive materials in such a way that a charge or voltage may appear across the two conductive materials.

Direct Current, DC: Current which flows in one direction only. The source of direct current is said to be polarized and has one terminal which is always at a higher potential than the other.

Hipot Tester: Common term for dielectric-withstand test equipment.

Hypot®: Registered trademark of Associated Research, Inc., for its dielectric-withstand test equipment.

Insulation: Gas, liquid or solid material which has a volume resistivity of at least 10^{12} ohm-cm and is used for the purpose of resisting current flow between conductors.

Insulation Resistance Tester: An instrument or a function of an instrument capable of measuring resistance's in excess of 200 megohms. Usually employs a higher voltage power supply than used in ohmmeters measuring up to 200 megohms.

Leakage: AC or DC current flow through insulation and over its surfaces, and AC current flow through a capacitance. Current flow is directly proportional to voltage. The insulation and/or capacitance is thought of as a constant impedance, unless breakdown occurs.

Resistance: That property of a substance which impedes current and results in the dissipation of power in the form of heat. The practical unit of resistance is the *ohm*. Symbol = **R**

Trip Point: The minimum current flow required to cause an indication of unacceptable performance during a dielectric voltage-withstand test.

Voltage: Electrical pressure, the force which causes current through an electrical conductor.
Symbol = **V**

INTRODUCTION

Product Safety Testing

The importance of testing... User safety

Product Safety Tests are specified during the design and development stages of a product as well as in the production of the products to insure that it meets basic safety requirements. These tests are designed to verify the safety of the electrical products in that they do not jeopardize the safety of the people, domestic animals, and property of anyone who may come in contact with these products. In an era of soaring liability costs, original manufacturers of electrical and electronic products must make sure every item is as safe as possible. All products must be designed and built to prevent electric shock, even when users abuse the equipment or by-pass built in safety features.

To meet recognized safety standards, one common test is the "dielectric voltage-withstand test". Safety agencies which require compliance safety testing at both the initial product design stage and for routine production line testing include: Underwriters Laboratories, Inc. (UL), the Canadian Standards Association (CSA), the International Electrotechnical Commission (IEC), the British Standards Institution (BSI), the Association of German Electrical Engineers (VDE) and (TÜV), the Japanese Standards Association (JSI). These same agencies may also require that an insulation resistance test and high current ground bond test be performed.

Line Leakage Testing

The Line Leakage test is one of many product safety tests which are normally specified for electrical products by safety testing agencies such as Underwriters Laboratories (UL) and the International Electrotechnical Committee (IEC). The line leakage specifications vary as well as the method in which the measurements are taken depending upon the application or function of a product and the standard to which the product is being tested. Current Leakage or Line Leakage tests are general terms that actually describe three different types of tests. These tests are Earth Leakage Current, Enclosure Leakage Current, and Applied Part Leakage Current. The main differences in these tests are in the placement of the probe for the measuring device. The Earth Leakage Current is the leakage current which flows through the ground conductor in the line cord back to earth. The Enclosure Leakage Current is the current that flows from any enclosure part through a person back to ground if it were contacted by a person. The Applied Part Leakage Current or Patient Lead Leakage Current is any leakage that flows from an applied part, between applied parts or into an applied part. The Applied Part Leakage Current test is required only for medical equipment. All of these tests are used to determine if products can be safely operated or handled without posing a shock hazard to the user.

The Model 510L LINECHEK Line Leakage Tester provides the capability of meeting the line leakage test specified in the following standards; UL 544, IEC 950, UL 1950, IEC 601-1, UL 2601, UL 1563, UL 3101, IEC 1010 and others. The Line Leakage test is a test which measures the leakage current of a product through a circuit which is designed

to simulate the impedance of the human body, this circuit is called the Measuring Device (MD). The instrument has five different MD circuits, selectable through the menu, which are representative circuits designed to simulate the impedances of the human body under different conditions. The impedance of the human body will vary depending upon point of contact, the surface area of the contact and the path the current flows. For these reasons the specifications on the Measuring Devices differ depending upon the type of test being performed as well as the maximum allowable leakage current. Leakage current measurements are performed on products under both normal conditions and single fault conditions as well as reversed polarity. This simulates possible problems which could occur if the product under test is faulted or misused while the product is operating under high line conditions (110% of the highest input voltage rating of the product).

Line Leakage tests are normally specified as "Type Tests" or "Design Tests" which are performed during the development of the product. This helps verify that the design is safe but it does not guarantee the safety of the products being produced on the production line. The only way to be sure you are shipping safe products is to test each product at the end of the production line.

The Dielectric Withstand (Hipot) Test

The principle behind a dielectric voltage - withstand test is simple. If a product will function when exposed to extremely adverse conditions, it can be assumed that the product will function in normal operating circumstances.

The most common applications of the dielectric-withstand test are:

- Design (performance) Testing.... determining design adequacy to meet service conditions.
- Production Line Testing.... detecting defects in material or workmanship during processing.
- Acceptance Testing.... proving minimum insulation requirements of purchased parts.
- Repair Service Testing.... determine reliability and safety of equipment repairs.

The specific technique varies with each product, but basically, during a dielectric voltage - withstand test, an electrical device is exposed to a voltage significantly higher than it normally encounters. The high voltage is continued for a given period of time.

During the test, all "stray" current flow to ground is measured. If, during the time the component is tested, stray current flow remains within specified limits, the device is assumed to be safe under normal conditions. The basic product design and use of the insulating material will protect the user against electrical shock.

The equipment used for this test, a dielectric-withstand tester, is often called a "hipot" (for high potential tester). The "rule of thumb" for testing is to subject the product to twice its normal operating voltage, plus 1,000 volts.

However, specific products may be tested at much higher voltages than 2X operating voltages + 1,000 volts. For example, a product designed to operate in the range between 100 to 240 volts, can be tested between 1,000 to 4,000 volts or higher. Most "double insulated" products are tested at voltages much higher than the "rule of thumb".

Testing during development and prototype stages is more stringent than production run tests because the basic design of the product is being evaluated. Design tests usually are performed on only a few samples of the product. Production tests are performed on each and every item as it comes off the production line.

The hipot tester must also maintain an output voltage between 100% and 120% of specification. The output voltage of the hipot must have a sinusoidal waveform with a frequency between 40 to 70 Hz and has a peak waveform value that is not less than 1.3 and not more than 1.5 times the root-mean-square value.

Advantages and Disadvantages of AC Testing and DC Testing....

Please check with the Compliance Agency you are working with to see which of the two type of voltages you are authorized to use. In some cases a Compliance Agency will allow either AC or DC testing to be done. However in other cases the Compliance Agency only allows for an AC test. If you are unsure which specification you must comply with please contact our CUSTOMER SUPPORT GROUP at 1-800-858-TEST (8378).

Many safety agency specifications allow either AC or DC voltages to be used during the hipot test. When this is the case the manufacturer must make the decision on which type of voltage to utilize. In order to do this it is important to understand the advantages and the disadvantages of both AC and DC testing.

AC testing characteristics

Most items that are hipot tested have some amount of distributed capacitance. An AC voltage cannot charge this capacitance so it continually reads the reactive current that flows when AC is applied to a capacitive load.

AC testing advantages

1. AC testing is generally much more accepted by safety agencies than DC testing. The main reason for this is that most items being hipot tested will operate at AC voltages and AC hipot testing offers the advantage of stressing the insulation alternately in both polarities which more closely simulates stresses the product will see in real use.
2. Since AC testing cannot charge a capacitive load the current reading remains consistent from initial application of the voltage to the end of the test. Therefore, there is no need to gradually bring up the voltage since there is no stabilization required to monitor the current reading. This means that unless the product is sensitive to a sudden application of voltage the operator can immediately apply full voltage and read current without any wait time.

3. Another advantage of AC testing is that since AC voltage cannot charge a load there is no need to discharge the item under test after the test.

AC testing disadvantages

1. A key disadvantage of AC testing surfaces when testing capacitive products. Again, since AC cannot charge the item under test, reactive current is constantly flowing. In many cases the reactive component of the current can be much greater than the real component due to actual leakage. This can make it very difficult to detect products that have excessively high leakage current.
2. Another disadvantage of AC testing is that the hipot has to have the capability of supplying reactive and leakage current continuously. This may require a current output that is actually much higher than is really required to monitor leakage current and in most cases is usually much higher than would be needed with DC testing. This can present increased safety risks as operators are exposed to higher currents.

DC testing characteristics

During DC hipot testing the item under test is charged. The same test item capacitance that causes reactive current in AC testing results in initial charging current which exponentially drops to zero in DC testing.

DC testing advantages

1. Once the item under test is fully charged the only current flowing is true leakage current. This allows a DC hipot tester to clearly display only the true leakage of the product under test.
2. The other advantage to DC testing is that since the charging current only needs to be applied momentarily the output power requirements of the DC hipot tester can typically be much less than what would be required in an AC tester to test the same product.

DC testing disadvantages

1. Unless the item being tested has virtually no capacitance it is necessary to raise the voltage gradually from zero to the full test voltage. The more capacitive the item the more slowly the voltage must be raised. This is important since most DC hipots have failure shut off circuitry which will indicate failure almost immediately if the total current reaches the leakage threshold during the initial charging of the product under test.
2. Since a DC hipot does charge the item under test it becomes necessary to discharge the item after the test.
3. DC testing unlike AC testing only charges the insulation in one polarity. This becomes a concern when testing products that will actually be used at AC voltages. This is a key reason that some safety agencies do not accept DC testing as an alternative to AC.

4. When performing AC hipot tests the product under test is actually tested with peak voltages that the hipot meter does not display. This is not the case with DC testing since a sinewave is not generated when testing with direct current. In order to compensate for this most safety agencies require that the equivalent DC test be performed at higher voltages than the AC test. The multiplying factor is somewhat inconsistent between agencies which can cause confusion concerning exactly what equivalent DC test voltage is appropriate.

The Insulation Resistance Test....

Some "dielectric analyzers today come with a built in insulation resistance tester. Typically the IR function provides test voltages from 500 to 1,000 volts DC and resistance ranges from kilohms to gigaohms. This function allows manufacturers to comply with special compliance regulations. BABT, TÜV and VDE are agencies that may under certain conditions require an IR test on the product before a Hipot test is performed. This typically is not a production line test but a performance design test.

The insulation resistance test is very similar to the hipot test. Instead of the go/no go indication that you get with a hipot test the IR test gives you an insulation value usually in Megohms. Typically the higher the insulation resistance value the better the condition of the insulation. The connections to perform the IR test are the same as the hipot test. The measured value represents the equivalent resistance of all the insulation which exists between the two points and any component resistance which might also be connected between the two points.

Although the IR test can be a predictor of insulation condition it does not replace the need to perform a dielectric withstand test.

TYPES OF FAILURES DETECTABLE ONLY WITH A HIPOT TEST

- Weak Insulating Materials
- Pinholes in Insulation
- Inadequate Spacing of Components
- Pinched Insulation

The Ground Bond Test

The Ground Bonding test determines whether the safety ground circuit of the product under test can adequately handle fault current if the product should ever become defective. A low impedance ground system is critical in ensuring that in the event of a product failure a circuit breaker on the input line will act quickly to protect the user from any serious electrical shock.

International compliance agencies such as CSA, IEC, TÜV, VDE, BABT and others, have requirements calling out this test. This test should not be confused with simple low current continuity tests that are also commonly called out in some safety agency

specifications. A low current test merely indicates that there is a safety ground connection, it does not completely test the integrity of that connection.

Compliance agency requirements vary on how different products are to be tested. Most specifications call for test currents of between 10 and 30 amps. Test voltages at these currents are typically required to be less than 12 volts. Maximum allowable resistance readings of the safety ground circuit are normally between 100 and 200 milliohms.

**IF YOU SHOULD HAVE ANY QUESTIONS RELATING TO THE OPERATION
OF YOUR INSTRUMENT CALL 1-800-858-TEST(8378) IN THE U.S.A.**

Model 510L Functional Specifications

510L INPUT	
Voltage	115/230 VAC \pm 15%, Single Phase, User selection
Frequency	50/60 Hz \pm 5%,
Fuse	2 A 250 V Slo-Blo
DUT POWER	
Voltage	30 - 300 VAC Single Phase Unbalanced (One Hot or Line conductor and One Neutral)
Current	30 AAC max continuous
Voltage Display	Range: 30.0 - 300.0 VAC Full Scale Resolution: 0.1 V Accuracy: \pm (1% of reading + 0.2 V)
Short Circuit Protection	32 AAC, Response Time < 600 ms
LEAKAGE CURRENT	
Current Display True RMS Responding	Range 1: 0.0 μ A - 999.9 μ A Resolution: 0.1 μ A/step Range 2: 1000 μ A - 6000 μ A Resolution: 1 μ A/step Accuracy: DC to 100 kHz \pm (1.5% of reading + 3 counts) >100 kHz to 1 MHz \pm 5% of reading, (10.0 μ A – 6000 μ A)
Measuring Device	A UL 544 Non Patient B UL 544 Patient C IEC 601-1, UL 2601, EN 60601-1 D UL 1563 E IEC 1010, UL 3101, IEC 950, UL 1950
MD A - D components	Accuracy: Resistance \pm 1% Capacitance \pm 5%
MD E components	Accuracy: Resistance \pm 0.1% Capacitance \pm 1%
MD Voltage Limit	Maximum 20 V peak or 20 VDC

HI-Limit / LO-Limit	Range: 0 - 6000 μ A (0 = Off) Resolution: 1 μ A Accuracy: Same as Leakage Current Display Accuracy
Delay Timer	Range: 0, 1.0 - 999.9 sec (0 = Constant) Resolution: 0.1 sec/step Accuracy: \pm (0.1% + 0.1 sec)
GENERAL SPECIFICATIONS	
PLC Remote Control	Input - Test, Reset, Execute memory # 1, # 2 and # 3 Output - Pass, Fail, Test-in-Process, and Reset
Memory	Allows storage of up to 10 groups of different test programs and 8 step/each memory.
Security	Programmable password lockout capability to avoid unauthorized access to test set-up program.
LCD Contrast Setting	9 ranges set by the numeric keys on the front panel.
Buzzer Volume Setting	10 ranges set by the numeric keys on the front panel.
Calibration	Software and adjustments are made through front panel.
Mechanical	Bench or rack mount with tilt up front feet.
Dimension	(W x H x D) 17 x 4 x 16.5 in. (432 x 102 x 419 mm)
Weight	15.9 lbs (7.2 Kgs)

KEY FEATURES & BENEFITS SUMMARY: MODEL 510L

FEATURES	BENEFITS
Provides 8 of the most common safety tests	No need to manually set up the test or to switch test leads around.
The 5 most common measuring devices are built-in and can be selected through software control	A versatile tester that can be set-up to meet multiple specifications without the need for complicated external connections, or the need for separate instruments.
Fully complies with the latest European Norms	Complies with the latest EN such as the Low Voltage Directive and Medical Directive.
Programmable security password system	Avoids tampering with settings by only allowing authorized personnel with a user programmable security password to change test parameters.
Front panel calibration	All calibration is done through a simple user interface from the front panel. No need to open the instrument.
PLC, RS-232 or GPIB Control	Provides flexibility for semi-automatic or automatic operation with a choice of communication protocols which provides the capability for easy test data storage.
Microprocessor control with software menuing	Microprocessor control allows for many advanced features such as automatic testing, memories and software control.
External measurement circuit	One external measurement circuit is provided for measurement of other devices.
Separate current trip points for each test	Each test can have a separate trip point for failure analysis.
50 Memories for test storage	Storage of test set-ups so parameters only need to be entered once then memorized.
Complete with software driver	National Instruments LabVIEW® software driver is provided for automated applications to ease the testing process.
Ranges from DC to 1 MHz	Complies with even the 1 MHz specification for IEC testing.

FRONT PANEL CONTROLS

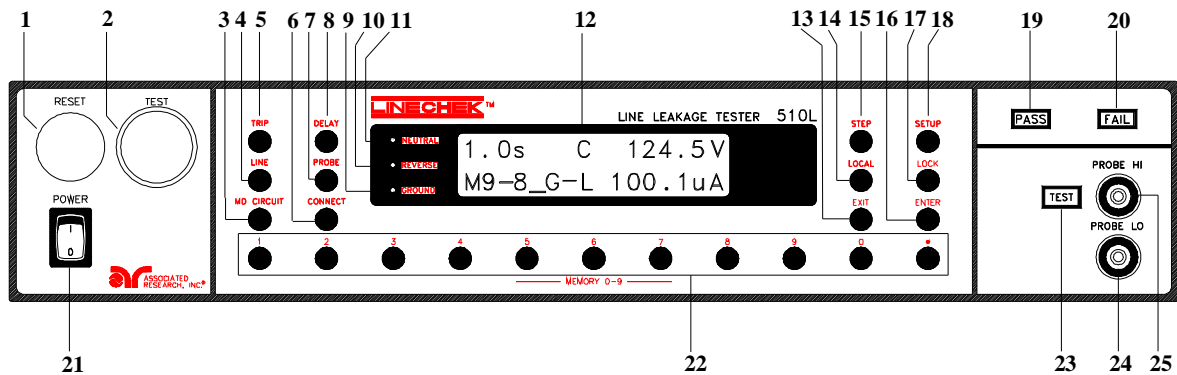

- 1. RESET BUTTON:** This is a momentary contact switch. If a failure condition occurs during a test you will need to reset the system to shut off the alarm and to signal the system that you are aware of a failure condition before you can proceed to the next test or change any of the set-up parameters. This switch also serves as an abort signal to stop any test in progress controlled by the LINECHEK.
- 2. TEST SWITCH:** This is a momentary contact switch. Press the green button to activate the leakage test which is set up in the memory location shown on the display. The switch will also illuminate to indicate a pass condition at the end of the test.
- 3. MD CIRCUIT:** Use this key to select the Measuring Device (MD) circuit A through F to simulate different body impedances. This setting will vary depending upon the standard to which the product is being tested. The LINECHEK has 5 internal MD circuits A-E which are shown below and 1 external measuring device which can be added if a new requirement is needed.

MD = A
UL 544 MEDICAL EQUIPMENT
Non patient equipment.

MD = B
UL 544 MEDICAL EQUIPMENT
Patient care equipment.

MD = C
IEC 601-1, UL 2601, EN 60601-1,
MEDICAL EQUIPMENT

MD = D
UL 1563 Electric Spas,
Equipment Assemblies and
Associated Equipment

MD = E
IEC 1010, UL 3101, IEC 950, UL 1950, EN 60950 LABORATORY EQUIPMENT,
INFORMATION TECHNOLOGY

- 4. LINE:** Use this key to activate the NEUTRAL, REVERSE, and GROUND relays to set up the steps within each memory for the single fault and normal conditions.
- 5. TRIP:** Use this key to set the trip current level for each step.

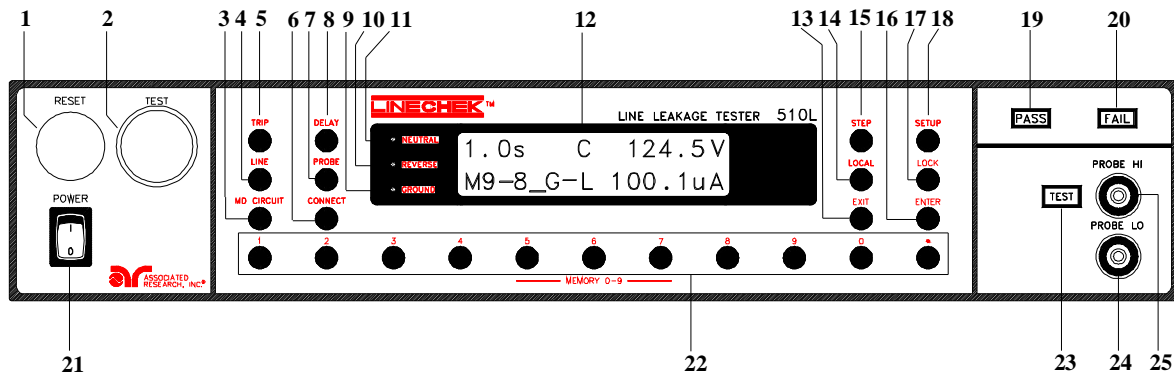

6. **CONNECT:** Use this key to sequence one step to the next step. The display will indicate M1-1_. The underbar indicates that step 1 is connected to step 2.
7. **PROBE:** Use this key to select the location of the MD circuit for the type of test being performed. G-L indicates the MD is connected to measure the leakage current in the earth ground conductor in the line cord back to the system neutral, an EARTH LEAKAGE TEST. P_H-L indicates the MD is connected between the PROBE-HIGH (P_H) terminal # 25 on the instrument which should be connected to the ENCLOSURE of the DUT through the system neutral, an ENCLOSURE LEAKAGE TEST. P_H-P_L indicates the MD is connected between the P_H and the PROBE-LO (P_L) terminal # 24 on the instrument which allow the operator to connect the MD between APPLIED PARTS.
8. **DELAY:** Use this key to program the delay time for making the leakage measurement for each step.
9. **GROUND LED:** This indicator will illuminate when the ground conductor to the DUT is open. This is one of the single fault conditions which is simulated during the leakage test.
10. **REVERSE LED:** This indicator will illuminate when the input power polarity to the DUT is reversed.
11. **NEUTRAL LED:** This indicator will illuminate when the neutral conductor to the DUT is opened. This is one of the single fault conditions which is simulated during the leakage test.
12. **LCD DISPLAY:** The 2x16 character display indicates the following test functions during a test; Probe Connections, Measuring Device Selection, Delay Time, Memory, Step Location, Input Voltage to DUT, and Leakage Current Reading. The display will also indicate various set up parameters.
13. **EXIT:** Use this key to exit any menu or to clear an unwanted entry in a parameter field.
14. **LOCAL:** Use this key when you wish to switch between remote and local operation of the instrument.

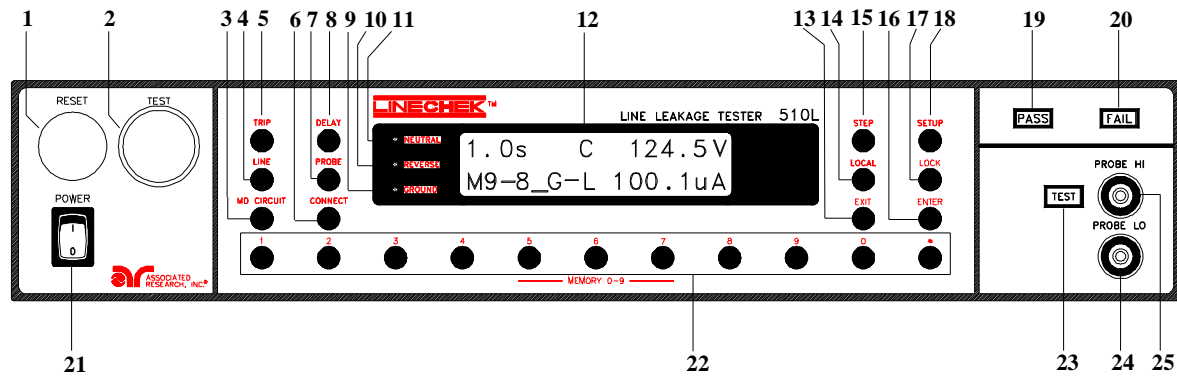

- 15. STEP:** Use this key to select one of the 8 locations contained within each memory. The step button will cycle through the steps as indicated on the display in the Set Screen. M1-1, M1-2, M1-3, etc.
- 16. SETUP:** Use this key to enter the setup menu. View or change the PLC Remote status, display contrast, alarm volume, GPIB address, Fail Stop setting, Single Step, and Memory Lock function.
- 17. LOCK:** Use this key to select key lockout mode. A password may be used when setup (Please refer to sections General Setup and System Setup).
- 18. ENTER / REVIEW KEY:** Use this key as an ENTER key to accept numeric data for parameter settings. Or use this key as a REVIEW key to recall up to 16 connected test results after a test has been completed.
- 19. PASS INDICATOR:** This LED indicator lights at the end of a test if a failure has not occurred.
- 20. FAIL INDICATOR:** This LED indicator lights at the end of a test if a failure has occurred during the test. Press the Reset button to clear the failure.
- 21. POWER SWITCH:** Rocker-style switch with international ON (I) and OFF (O) markings.
- 22. DATA ENTRY KEYS:** Use these keys to input numeric parameters followed by the ENTER key. Also used to recall test parameters stored in memory 0-9.
- 23. TEST LED:** This indicator will illuminate when the DUT has voltage applied to it, and the Line Leakage test is active.
- 24. PROBE LO:** This connector is an input to one side of the MD which is activated by pressing the PROBE button # 7, when the display indicates P_H-P_L for performing Applied Part leakage measurements.

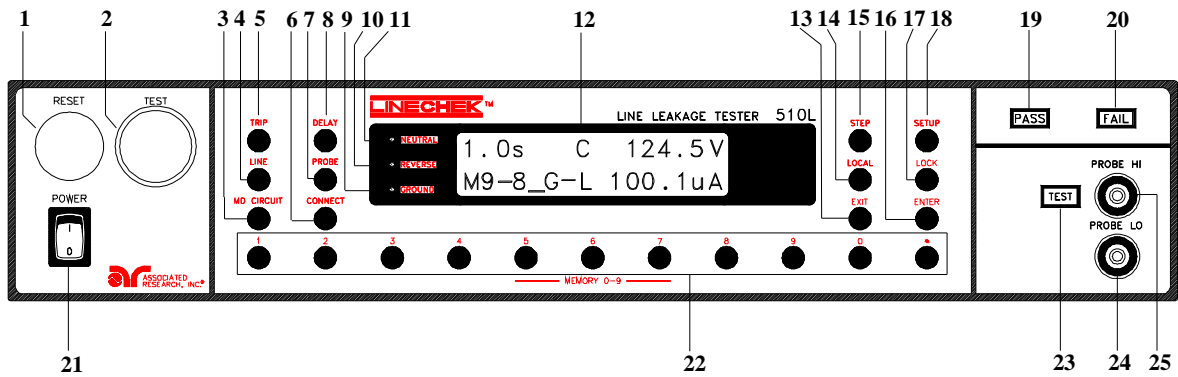

25. PROBE HI: This terminal is an input to one side of the MD which is activated by pressing the PROBE button # 7, when the display indicates either P_H-L or P_H-P_L for performing Enclosure leakage or Applied Part leakage measurements. When doing an Enclosure Leakage test the lead from the Probe HI terminal should be connected to the enclosure. When performing an Applied Part test the lead should be connected to the applied part.

REAR PANEL CONTROLS

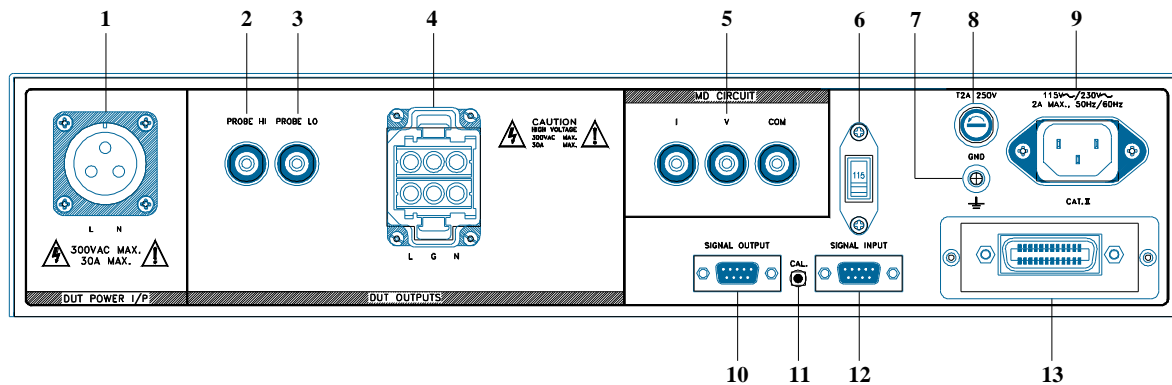

1. **DUT POWER INPUT TERMINAL:** This connector is the LINE and NEUTRAL input power connections. An external single phase unbalanced AC power supply with a single Hot or Line conductor should be connected here, to supply power to the DUT while performing the leakage test. This input is rated for 0-300 volts, 30 A maximum.
2. **PROBE HI:** This terminal is an input to one side of the MD which is activated by pressing the PROBE button #7, when the display indicates either P_{H-L} or P_{H-P_L} for performing Enclosure leakage or Applied Part leakage. This terminal and the PROBE HI terminal # 25 on the front panel are connected in parallel during the Line Leakage test. When the external link is active this terminal is isolated from the line leakage test circuits.
3. **PROBE LO:** This terminal is an input to one side of the MD which is activated by pressing the PROBE button #7, when the display indicates P_{H-P_L} for performing Applied Part leakage measurements. This terminal and the PROBE LO terminal # 24 on the front panel are connected in parallel during the Line Leakage test. When the external link is active this terminal is isolated from the line leakage test circuits.
4. **DUT OUTPUT TERMINAL:** This output terminal is where the LINE, NEUTRAL and GND power connections from the adapter box is plugged into the LINECHECK. Line power is supplied to the DUT during the leakage test through this terminal. This output is rated for 0-300 volts, 30 A maximum.
5. **EXTERNAL MEASURING DEVICE CONNECTORS:** These connectors allow the operator to connect an external Measuring Device circuit to the LINECHECK. These terminals are activated when the display indicates MD=F. The external measuring device may allow the operator to test to a different standard, which calls for a different measuring device, or to easily change the measuring device if the standard requirements change.

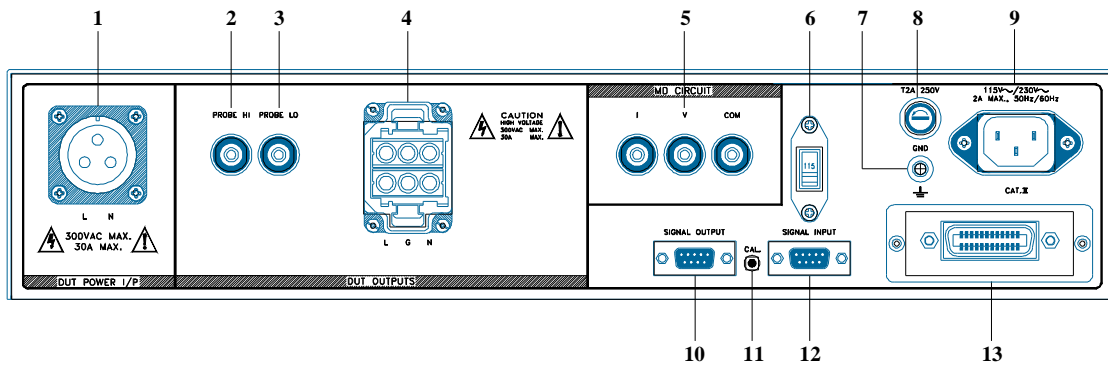

6. **INPUT POWER SWITCH:** Line voltage selection is set by the position of this switch. In the down position it is set for 110-120 volt operation, in the up position it is set for 220-240 volt operation.
7. **CHASSIS GROUND (EARTH) TERMINAL:** This terminal should be connected to a good earth ground before operation.
8. **FUSE RECEPTACLE:** To change the fuse unplug the power (mains) cord and turn the fuse receptacle counter-clockwise. The fuse compartment will be exposed. Please replace the fuse with one of the proper rating.
9. **INPUT POWER RECEPTACLE:** Standard IEC 320 connector for connection to a standard NEMA style line power (mains) cord.
10. **REMOTE SIGNAL OUTPUT:** 9-Pin D subminiature female connector for monitoring PASS, FAIL, and PROCESSING output relay signals.
11. **CALIBRATION ENABLE KEY:** This key is used during power up to enable the calibration routines.
12. **REMOTE SIGNAL INPUT:** 9-Pin D subminiature male connector for remote control of test and reset functions as well as program memory selection 1, 2, or 3.
13. **GPIB:** Standard connector for interconnection to the GPIB interface. Optional RS-232 interface can be substituted for this interface.

INSTALLATION

Introduction

This section contains information for the unpacking, inspection, preparation for use and storage of your Associated Research, Inc., product.

Unpacking and Inspection

Your instrument was shipped in a custom foam insulated container that complies with ASTM D4169-92a Assurance Level II Distribution Cycle 13 Performance Test Sequence.

If the shipping carton is damaged, inspect the contents for visible damage such as dents, scratches or broken meters. If the instrument is damaged, notify the carrier and the Associated Research customer support department immediately. Please save the shipping carton and packing material for the carriers inspection. Our customer support department will assist you in the repair or replacement of your instrument. Please do not return your product without first notifying us and receiving an RMA (return material authorization) number.

PREPARATION FOR USE

Power Requirements and Line Voltage Selection

This instrument requires a power source of either 115 volts AC \pm 15%, 47-63 Hz single phase or 230 volts AC \pm 15%, 47-63 Hz single phase. Please check the rear panel to be sure the proper switch setting is selected for your line voltage requirements before turning your instrument on.

CAUTION Do not switch the line voltage selector switch located on the rear panel while the instrument is on or operating. This may cause internal damage and represents a safety risk to the operator.

NOTE: For operation at 115 and 230 Volts AC use a 2A slow-blow fuse.

Power Cable

WARNING BEFORE CONNECTING POWER TO THIS INSTRUMENT, THE PROTECTIVE GROUND (EARTH) TERMINALS OF THIS INSTRUMENT MUST BE CONNECTED TO THE PROTECTIVE CONDUCTOR OF THE LINE (MAINS) POWER CORD. THE MAIN PLUG SHALL ONLY BE INSERTED IN A SOCKET OUTLET (RECEPTACLE) PROVIDED WITH A PROTECTIVE GROUND (EARTH) CONTACT. THIS PROTECTIVE GROUND (EARTH) MUST NOT BE DEFEATED BY THE USE OF AN EXTENSION CORD (POWER CABLE) WITHOUT A PROTECTIVE CONDUCTOR (GROUNDING).

This instrument is shipped with a three-wire power cable. When this cable is connected to an appropriate AC power source, this cable connects the chassis to earth ground. The type of power cable shipped with each instruments depends on the country of destination.

Environmental Conditions

This equipment is intended for indoor use only. The equipment has been evaluated according to Installation Category II and Pollution Degree 2 as specified in IEC 664.

This instrument may be operated in environments with the following limits:

Temperature.....32° - 104° F (0° - 40° C)

Relative humidity0 - 80%

Altitude6,560 feet (2,000 meters)

Storage and Shipping Environment

This instrument may be stored or shipped in environments with the following limits:

Temperature.....-40° - 167° F (-40° - 75°C)

Altitude.....50,000 feet (15,240 meters)

The instrument should also be protected against temperature extremes that may cause condensation within the instrument.

Packaging

Original Packaging: Please retain all original packaging materials that you originally received. If you are returning your instrument to us for servicing please repackage the instrument in its original container. Contact our customer support department (1-800-858-8378) for a RMA (return material authorization) number. Please enclose the instrument with all options, accessories and test leads. Indicate the nature of the problem or type of service needed. Also, please mark the container "FRAGILE" to insure proper handling. Upon receipt your instrument will be issued an AR service number. Please refer to this number in all correspondence.

Other Packaging: If you do not have the original packaging materials please follow these guidelines:

- 1). Wrap the instrument in a bubble pack or similar foam. Enclose the same information as above.
- 2). Use a strong double-wall container that is made for shipping instrumentation. 350 lb. test material is adequate.
- 3). Use a layer of shock-absorbing material 70 to 100 mm (3 to 4 inch) thick around all sides of the instrument. Protect the control panel with cardboard.
- 4). Seal the container securely.
- 5). Mark the container "FRAGILE" to insure proper handling.
- 6). Please refer in all correspondence to your AR service number.

Field Installation Of Options

There are no field installable options on this instrument.

QUICK START

This quick start guide assumes the operator has some familiarity with automated testing and desires to use the "**default**" settings on the instrument. The default settings shown will remain in memory unless you choose to override them with your own test program. The instrument default settings that appear in memories 1-40 are as follows:

DEFAULTS

Type	Parameter	Value			
		Step	Neutral	Reverse	Ground
Function	Line	1	Fault	Normal	Fault
		2	Fault	Fault	Fault
		3	Fault	Normal	Normal
		4	Fault	Fault	Normal
		5	Normal	Normal	Fault
		6	Normal	Fault	Fault
		7	Normal	Normal	Normal
		8	Normal	Fault	Normal
	Probe	G-L			
	MD Circuit	C (IEC 601)			
	Connect	Step 1-7 = ON; Step 8 = OFF			
	Trip	0 μ A			
	Delay	1.0s			
Setup	PLC Remote	OFF			
	Contrast	5			
	Volume	5			
	Address (GPIB only)	5			
	Fail Stop	ON			
	Single Step	OFF			
Calibration	Password	0			
	Memory Lock	ON			

Quick Start Instructions Cont.:

1. Unpack the instrument from its special shipping container. Be sure to save all packaging materials in case you need to return it to the factory for service.
2. Locate a suitable testing area and be sure you have read all safety instructions for the operation of the instrument and suggestions on the test area set-up in the Safety section. Locate a three prong grounded outlet. Be sure the outlet has been tested for proper wiring before connecting the instrument to it.

WARNING
3. Check to be sure the correct input line voltage has been selected on the rear panel. Either

CAUTION

 115 volts AC or 230 volts AC. Connect the power input plug into its socket on the rear panel of the instrument. Connect the male end of the

plug to the outlet receptacle. Please be sure that the safety ground on the power line cord is not defeated and that you are connecting to a grounded power source.

- Connect the appropriate test leads to the device under test (DUT) or test fixture. Connect the DUT power input to a AC Power Source that will provide line power to the DUT. The Power Source must be an unbalanced single phase supply. This means that there is only one HOT or LINE conductor and the other conductor of the power source must be at low voltage reference potential. Be sure that the hot lead of the power source is connected to the L (line) terminal and the reference or low voltage lead is connected to the N (neutral) terminal.

Connect the adapter box to the DUT output connector on the rear panel. Plug the three prong line cord of the DUT into the adapter box. Be sure to connect the safety ground to a suitable known good ground before energizing this instrument.

The DUT is now connected properly to perform the Line Leakage test that is configured into memory. The LINECHEK will measure leakage currents in series with the ground lead of the DUT as indicated by the G-L probe configuration on the LCD display. The G-L configuration is known as the Earth Leakage test.

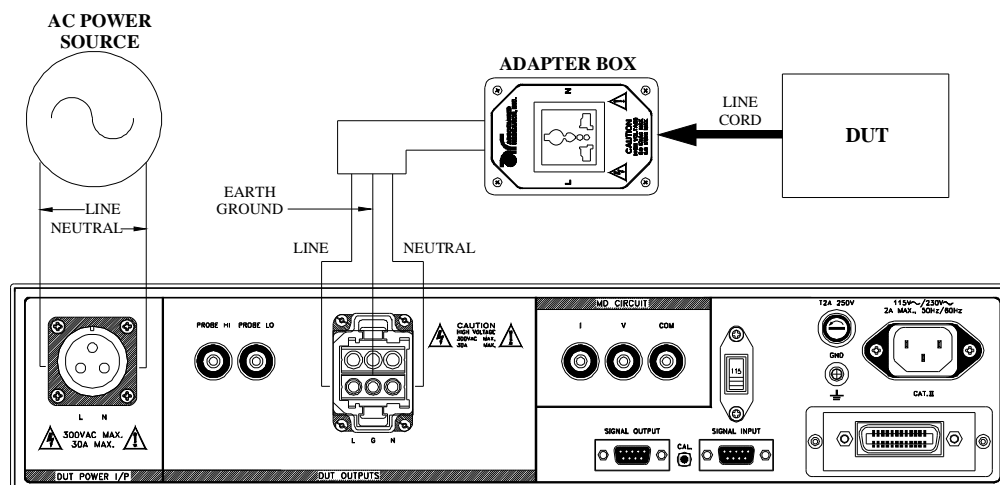

- Turn on the POWER switch located on the lower left hand side of the front panel. Upon powering up the instrument, all LEDs on the front panel will be lit for visual inspection. If the instrument defaults parameters are not acceptable, refer to the OPERATION section for detailed instructions on setting up testing parameters.

WARNING

DO NOT TOUCH THE DEVICE UNDER TEST ONCE THE TEST HAS BEEN STARTED.

- Check your connections to be sure they are making good contact. Clear the test station/area of debris and ask any unnecessary personnel to leave the area. To initiate the test press the GREEN test button on the front panel. This is a momentary button and

does not need to be held in the pressed position during the test. The instrument will then cycle ON and begin the automated test sequence using the defaults. As the test sequence proceeds, you will hear relays clicking inside the LINECHECK and will observe the three LEDs (Neutral, Reverse and Ground) to the left of the LCD display turning on and off to indicate the different line configurations. A fault condition is indicated when the LED is on. When the LED is off the connection is in a normal state. If a failure occurs you will hear an audible alarm and see the red failure indicator light up. To stop the alarm you must press the RED button marked "RESET." This will silence the alarm, clear the red fail light, and reset the instrument to begin another test.

This RESET button may also be used to quickly ABORT a test and cut off the power to the DUT. When VOLTAGE is present a RED TEST indicator located in the lower right side of the front panel near the probe connectors will illuminate until the VOLTAGE is shut OFF. If the device under test PASSED the test then no audible alarm will sound. You will hear a brief BEEP to let you know the item was successfully tested and it PASSED. In the case of a FAIL condition the instrument will provide a memory of the test results on the display, that will remain until the next test is initiated. Pressing the RESET button will prepare the instrument for the next test but will not clear the display until the next test is started or another reset is executed.

1. General Setup Procedures

1.1 Password Setting

Press and hold the SETUP key while power on the instrument, the program will enter the Password setting mode. The display will show:

Password = 0 Range : 0 - 9 9 9 9

or

Password = X X X X Range : 0 - 9 9 9 9

The Password can be any four (4) digit number. If the Password is set to 0, the keyboard lock out will be selected by the LOCK key on the front panel without a Password. The Password default is preset to 0 at the factory. The password will be saved automatically when the ENTER key is pressed and the instrument will return to normal operation.

1.2 Key Lock

Press the LOCK key. If the Password is Enabled, the display will show:

Password = _ Range : 0 - 9 9 9 9

Use the Numeric Keys to enter the password and then press the ENTER key. The program will switch the Key Lock function from LOCK to UNLOCK or UNLOCK to LOCK mode and advance the program to operation mode automatically. If the wrong password is entered, the program will give a warning beep and the display will momentarily show ERROR and then return to the previous screen to allow a new password entry.

Password = ERROR Range : 0 - 9 9 9 9

Press the EXIT key to return to the operation mode.

If the Password is Disabled (Password is set 0), the display will show:

Key Lock = O N ENTER to select

or

Key Lock = O F F ENTER to select

Use the ENTER key to select the Key Lock mode, then press the EXIT key. The program will switch the Key Lock function from LOCK to UNLOCK or UNLOCK to LOCK mode and advance the program to the operation mode automatically.

If the Memory Lock function is set to ON, the Memory selection Menu will be disabled when in the Lock Mode. If the Memory Lock is set to OFF, the Memory selection Menu will be enabled when in the Lock Mode. Different memories can be recalled but the test parameters or steps cannot be changed. The Memory Lock

default is preset to ON at the factory. Please refer to the System Parameter Setup section to set the Memory Lock mode.

1.3 Memory Configuration

Each memory location contains 8 separate steps which can be connected sequentially to the next consecutive step. The following memory map illustrates the separate locations for each step within each memory.

Memory map

Memory 0	Step 1	Step 2	Step 8
Memory 1	Step 1	Step 2	Step 8
.				
.				
.				
Memory 9	Step 1	Step 2	Step 8

1.4 Memory Program

Press the NUMERIC Keys 0-9 to enter the Memory location number. The program will recall the test parameters stored in this location and the instrument will respond with a short beep tone.

1.5 Step

Press the STEP key, the display will show the test parameters selected for that step. Pressing the step key again will advance to the next step in sequence with step 1 following step 8.

Note: When the steps have been interconnected you will see an underbar character on the display just after the step number. This indicates that the step after the active step will run immediately after the active step is completed. The display will show:

XXX.X s	A	XXX.X V
M5-1_	G-L	XXX.X μ A

2. Test Parameter Setup Procedures

Before going to setup the Test Parameters, make sure that the key lock function is set to Unlock mode, then follow this procedures to setup the Test Parameters.

2.1 High Trip

The High current trip limit is used to program the maximum allowable leakage current limit for each configuration that has been selected for each step.

Press the TRIP key, the display will show:

HI-Trip: 1000 μ A
Range: 0, 1 - 6000

Use the Numeric Keys to enter the trip current value, and then press the ENTER key. The program will store this value and advance to the LO-Trip parameter automatically. When the trip current is set to 0 μ A the High current trip limit will be disabled.

2.2 Low Trip

The Low current trip limit is used to program the minimum allowable leakage current limit for each configuration that has been selected for each step.

Press the TRIP key twice, the display will show:

LO-Trip: 1000 μ A
Range: 0, 1 - 6000

Use the Numeric Keys to enter the trip current value, and then press the ENTER key. The program will store this value and advance to the HI-Trip parameter automatically. When the trip current is set to 0 μ A the Low current trip limit will be disabled. Press the EXIT key to return to the operational mode.

2.3 Delay Time

The Delay Time setting is used to program the amount of time that may be needed to delay the trip current detectors until the DUT has reach proper operating conditions. The trip current judgment is activated at the end of the Delay Time. The instrument will not indicate that the Trip Current limit has been exceeded until the Delay Time period has expired. Press the DELAY key, the display will show:

Delay 2.5 s
Range 0, 1-999.9

Use the Numeric Keys to enter the Delay Time value, and then press the ENTER key. The program will store this value and return to the operation mode automatically.

2.4 Line Configuration

The LINE configuration is determined by the relays S1, S2 and S3 shown in figure 1 below. The three relays can be configured into eight possible combinations. The three relays are represented on the front panel by the three LEDs (NEUTRAL, REVERSE, and GROUND) to the left of the display. S1 relay is represented as NEUTRAL. S2 relay is represented as REVERSE. S3 relay is represented as GROUND. When an LED is ON it indicates that the relay is in a faulted condition when the LED is OFF it indicates that the relay is in a normal or good operating condition. For example, when the NEUTRAL or GROUND LED is ON it indicates that the relay is opened and represents a fault in the line input wiring. When the REVERSE LED is ON this represents that the relay is in position B indicating that the Line and Neutral conductors are reversed at the DUT power outputs shown as the DUT power receptacle in figure 1.

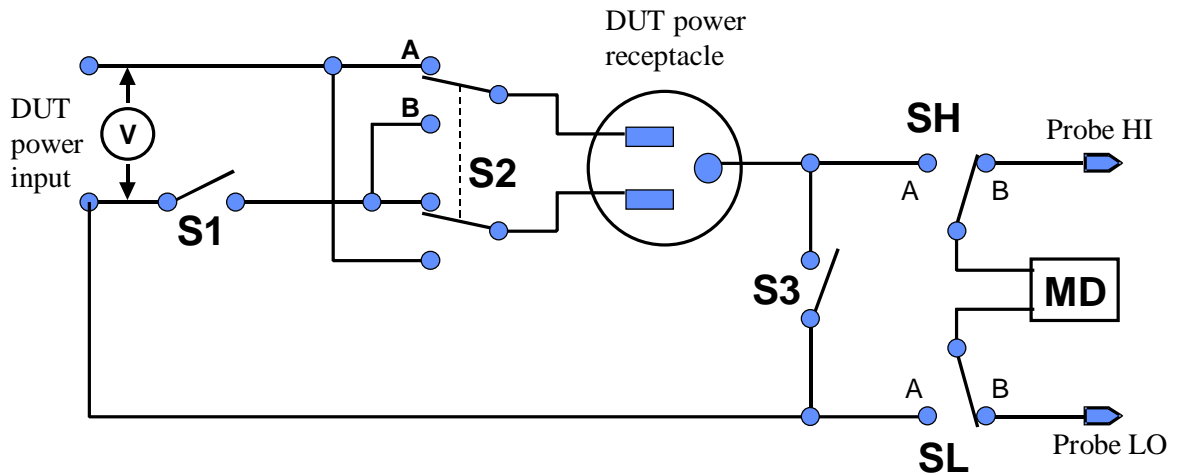

Figure 1

To change the Line configuration press the LINE key. The line configuration will change each time the key is pressed in a sequential order represented in the table below.

Step	NEUTRAL		REVERSE		GROUND	
	Relay	LED	Relay	LED	Relay	LED
1	Open	ON	A	OFF	Open	ON
2	Open	ON	B	ON	Open	ON
3	Open	ON	A	OFF	Closed	OFF
4	Open	ON	B	ON	Closed	OFF
5	Closed	OFF	A	OFF	Open	ON
6	Closed	OFF	B	ON	Open	ON
7	Closed	OFF	A	OFF	Closed	OFF
8	Closed	OFF	B	ON	Closed	OFF

When the LEDs represent the desired line configuration the test is ready to start. No other keystrokes are necessary. The line configuration settings are automatically saved in memory.

2.5 Probe Configuration

The Probe configuration is controlled by the relays SH and SL in Figure 1 of the previous section 2.3. These two relays configure the current measuring device into three possible positions. The three positions are described in the table below.

Measuring Device Position	SH	SL	Display Indication	Agency Test Application
Ground to Line	A	A	G-L	Earth Leakage
Probe HI to Line	B	A	P _H -L	Enclosure Leakage or Patient Leakage
Probe-HI to Probe-LO	B	B	P _H -P _L	External Applied Part or Surface to Surface Leakage

G-L indicates the MD is connected to measure the leakage current in the earth ground conductor in the line cord back to the system neutral, an EARTH LEAKAGE TEST. P_H-L indicates the MD is connected between the PROBE HI (P_H) terminal on the instrument, which should be connected to the ENCLOSURE of the DUT and the system neutral. This is known as an ENCLOSURE LEAKAGE TEST. P_H-P_L indicates the MD is connected between the PROBE HI (P_H) and the PROBE LO (P_L) terminals on the instrument which allow the operator to connect the MD between applied parts.

The LCD display will indicate the Probe configuration in the center of the second line. The ground to line configuration will be indicated as follows:

1 . 0 s	D	110.2V
M1-1_	G-L	2500μA

To change the Probe configuration press the PROBE key. The Probe configuration will change each time the key is pressed, in sequential order. When the display indicates the desired Probe configuration, the test is ready to start. No other key strokes are necessary to finish the configuration. The Probe configuration settings are automatically saved into memory.

2.6 Measuring Device

The Measuring Device is the human body impedance circuit that is specified in the agency specification for leakage current tests. The following table indicates the measuring device letter designation used by 510L and the appropriate agency standard that it correlates to.

LINECHEK Designation	Agency Specification	Application
A	UL 544 Non patient equipment	Medical Equipment
B	UL 544 Patient care equipment	Medical Equipment
C	IEC 601-1, UL 2601, EN 60601-1	Medical Equipment
D	UL 1563	Electric Spas, Equipment Assemblies and Associated Equipment
E	IEC 1010, UL 3101, IEC 950, UL 1950, EN 60950	Laboratory Equipment. Information Technology.

Circuit Diagrams

The following diagrams show the equivalent circuit of the measuring devices. Leakage current readings are generated by measuring the voltage drop across these networks and dividing by the equivalent DC resistance. The volt meter is placed across the entire network of measuring device A, B and D, but is placed across the points indicated by the solid black dots on measuring device C and E, as specified in the agency specifications that apply to the particular measuring device.

MD = A

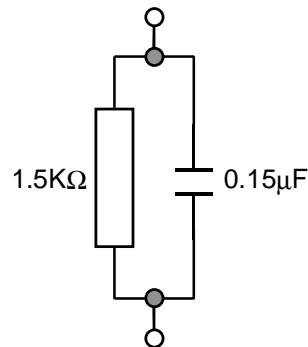

MD = B

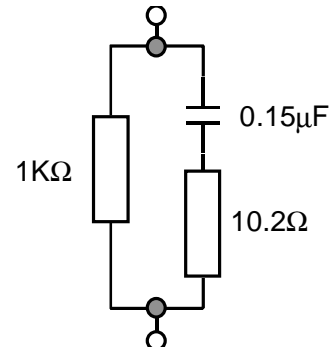

MD = C

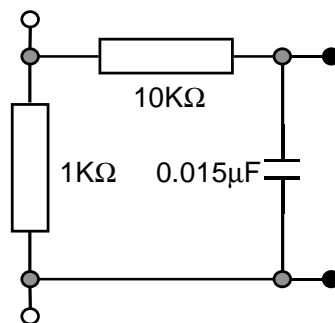

MD = D

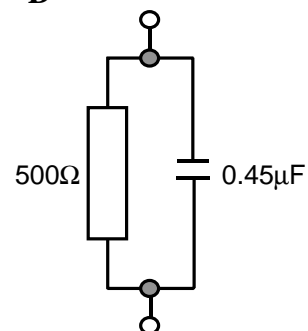

MD = E

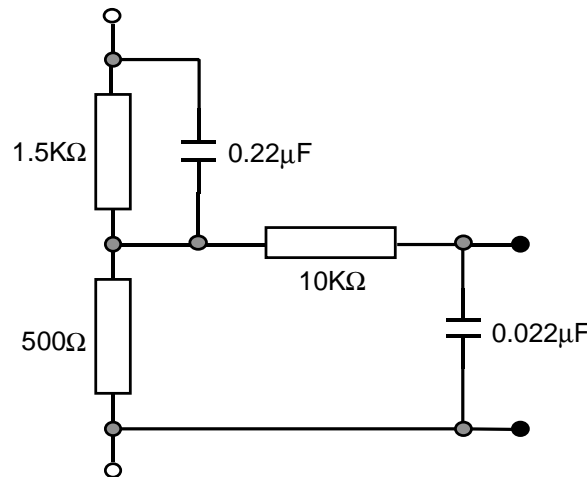

The display will indicate the Measuring Device in the center of the first line of the LCD display. The Measuring Device is indicated with letters A through F. Measuring Device A will be displayed as follows:

1.0 s	A	110.2V
M1-1_	G-L	2500μA

To change the Measuring Device, press the MD CIRCUIT key. The Measuring Device will change each time the key is pressed, in sequential order. When the display indicates the desired Measuring Device, the test is ready to start. No other key strokes are necessary to save the configuration. The Measuring Device settings are automatically saved into memory.

2.7 Connect Configuration

The connect feature of the LINECHEK allows the instrument to link the individual STEP configurations together into a sequence of tests. Each of the eight steps within a memory location can be linked together, as well as linking the last step of a memory to the first step of the next memory. Therefore the possibility exists to link 400 different configurations together as one test sequence.

To change the connect configuration for an individual step, press the CONNECT key. An underbar character will be present next to the Step number when the connect feature is turned ON. The display will indicate the connection as follows:

1.0 s	A	110.2V
M1-1_	G-L	2500μA

By pressing the CONNECT key again, the underbar character will be removed and replaced with a blank space and Step connection will be turned OFF.

3. System Parameter Setup

Use the SETUP key to progress through the menu of System Parameters. Successive key presses will advance the menu forward. The sequential forward menu items are PLC Remote, Contrast, Volume, Address, Fail Stop, Single Step, and Memory Lock.

The setting of system parameters affect the operating conditions of the instrument and are separate from the functional settings. The system settings are also global and are not specific to any memory location.

3.1 PLC Remote

Press the SETUP key to advance to the PLC Remote parameter. The display will show:

PLC Remote = ON ENTER to select

or

PLC Remote = OFF ENTER to select

Use the ENTER key to select the PLC Remote Control mode.

After selecting PLC Remote mode, press the SETUP key to advance to the address setting if the GPIB interface card is installed on this instrument. If this instrument does not have the GPIB interface card, the program will advance to the contrast setting, or press the EXIT key to exit from the PLC Remote selection to the operation mode. The instrument will store the selection of PLC Remote automatically.

If the Remote Control is set to ON, the test function will be controlled by the Remote Control via the remote connectors located on the rear panel. The TEST button on the front panel is disabled but the RESET button is still enabled.

The remote Memory Program recall functions can be performed only when the PLC Remote is set ON. In addition, when the PLC remote is set to ON the remote TEST signal input is active while in the Bus Remote Mode.

If the Remote Control is set to OFF, the operation of the instrument will be controlled by the local TEST and RESET buttons on the front panel.

3.2 LCD Contrast

Press the SETUP key to advance the menu to the Contrast parameter. The display will show:

Contrast = X Range 1-9 9=High

Use the numeric keys to enter the LCD Contrast level. The program will change the LCD Contrast immediately when the key is pressed, so the setting can be viewed.

Change the LCD Contrast again or press the SETUP or ENTER key to advance to the Volume setting, or press the EXIT key to exit from the LCD Contrast setting to the operation mode. The program will store the Contrast setting automatically.

The LCD Contrast range is from 1 - 9, a total of 9 levels. Level 1 is the lowest contrast and level 9 is the highest contrast.

3.3 Audible Alarm Volume

Press the SETUP key to advance the menu to the Volume parameter. The display will show:

Volume = X 0-9 0=OFF 9=High

The Audible Alarm Volume range is from 0 - 9, a total of 10 levels. Level 0 is used to disable the Audible Alarm. Level 1 is the lowest volume and level 9 is the loudest.

Use the numeric keys to enter the Audible Alarm level. The program will provide a sample sound for checking immediately when the numeric key is pressed.

Change the Volume again or press the SETUP or ENTER key to forward to address setting if the GPIB interface card is installed on this instrument. If this instrument does not have the GPIB interface card, the program will advance to the Fail Stop selection program, or press the EXIT key to exit from the Audible Alarm setting to the operation mode. The program will store the Volume setting automatically.

3.4 GPIB Address

If the GPIB interface card is not installed on this instrument, this setup program will not appear on the setup menu.

Press the SETUP key to advance the menu to the address parameter. The display will show:

Address = X Range : 0 - 30

Use the numeric keys to enter the GPIB Address number, then press the ENTER key. The program will store the address setting automatically and advance to the Fail Stop selection.

If the wrong address is entered, press the EXIT key to erase last input and return to previous address. Press the EXIT key second time to exit from the address setting to the operation mode or press the SETUP key to advance to the Fail Stop selection.

3.5 Fail to Stop/Continue

Press the SETUP key to advance the menu to the Fail Stop parameter. The display will show:

Fail Stop = ON ENTER to select	or	Fail Stop = OFF ENTER to select
-----------------------------------	----	------------------------------------

Use the ENTER key to select the mode of Fail Stop.

After the selection of Fail Stop mode, press the SETUP key to advance to the Single Step selection, or press the EXIT key to exit from the Fail Stop selection to the operation mode. The Program will store the selection of Fail Stop automatically.

This function is used when multiple steps have been connected. If the Fail Stop mode is set ON, the test process will stop at the step that fails, or at the end of test process. When there are unfinished steps to be completed, pressing the TEST button will continue the test process at the next step. Pressing the RESET button and then the TEST button will start the test process from the first step.

If the Fail Stop is set to OFF, the instrument will continue to complete the entire test process even if there were failed steps during the test. The display will show the results of each step at the end of test process, as follows:

T	P	F	P	F	P	F	P	F	P	F	P	F	P	F	P
S	1	2	3	4	5	6	7	8	1	2	3	4	5	6	7

← First Memory Program →	← Second Memory Program →
---------------------------------	----------------------------------

The pass fail status is indicated by the letter F (Fail) or P (Pass). The Pass/Fail status of the first memory Program will show on the left end and the second one will be on the right. The pass/fail status of the first 16 steps can be displayed. A maximum of 16 steps will be saved. If more than 16 steps are executed in sequence, results from those steps greater than 16 cannot be retrieved from memory.

3.6 Single Step

Press the SETUP key to advance the menu to the Single step parameter. The display will show:

Single Step = ON ENTER to select	or	Single Step = OFF ENTER to select
-------------------------------------	----	--------------------------------------

Use the ENTER key to select the Single step mode.

After the selection of Single step mode, press the SETUP key to advance to the Memory Lock selection, or press the EXIT key to exit from the Single step selection

to the operation mode. The Program will store the selection of Single step automatically.

This function is used to temporarily override the automatic connection feature. When the single step function is ON the instrument will pause after each step is completed. To continue the test sequence, press the Test button to execute the next connected step. Each time the Test button is pressed the next connected step will execute. The first step of the sequence will execute, when the Test button is pressed after the last step of the sequence has completed.

3.7 Memory Lock selection

Press the SETUP key, the program will advance to the Memory Lock selection mode. The display will show:

Memory Lock = O N ENTER to select

or

Memory Lock = O F F ENTER to select
--

If the Memory Lock is selected ON, the Memory selection Menu will be disabled when in Lock Mode. If the Memory Lock is selected OFF, the Memory selection Menu will be enabled when in Lock Mode. Different memories can be recalled but the test parameters or steps can not be changed. The Memory Lock default is preset to ON at the factory.

After the selection of Memory Lock mode, press the SETUP key to advance to the beginning of the menu (PLC Remote), or press the EXIT key to exit from the Memory Lock selection to the operation mode. The program will store the selection of Memory Lock automatically.

4. Operation Procedure

4.1 Setup

Before the operation of this instrument, make sure that all Test Parameters have been set properly according to the Test Parameters Setup Procedures. Also check the system setting of Remote Control, LCD Contrast, Alarm Volume, Fail Stop, Single Step, and Memory Lock.

WARNING



The Power Source to the DUT inputs must be an unbalanced single phase supply. This means that there is only one HOT or LINE conductor and the other conductor of the power source must be at a low voltage reference potential. This low voltage reference does not need to be physically earth grounded but should not carry any large voltage potential. The 220 - 240V US style line power **IS NOT** suitable to be connect to the DUT inputs. This style of power distribution is a balanced type with two HOT or LINE conductors. **DO NOT** connect a line conductor to the N or Neutral terminal of the DUT inputs. This condition can be very dangerous to the LINECHECK user.

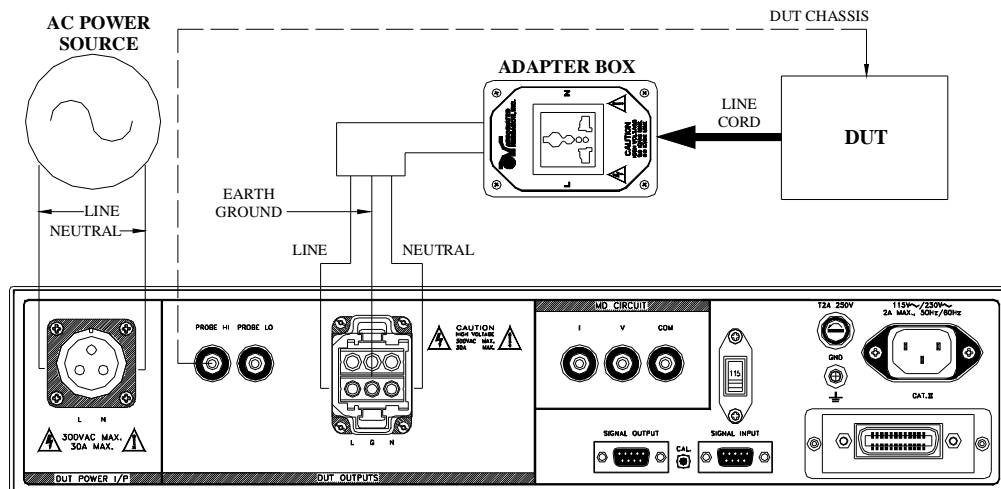

Be sure to connect the appropriate test leads to the device under test (DUT) or test fixture, as shown in the diagram below. Please be sure to use a Power Source which has only one line conductor that is of the balanced type as stated previously. Be sure to connect the safety ground terminal (on the rear panel) to a suitable known good ground before energizing this instrument.

The dotted line at the Probe HI output illustrates the connection for an ENCLOSURE LEAKAGE TEST required by the agencies. The Probe HI connection could also be used together with the Probe LO connection to perform other leakage tests that are not illustrated here. Check your connections to be sure they are making good contact. Clear the test station/area of debris and ask any unnecessary personnel to leave the area.

WARNING

DO NOT TOUCH THE DEVICE UNDER TEST ONCE THE TEST HAS BEEN STARTED.

4.2 Power Up

Turn on the Input Power Switch. All status LEDs will light up, then the display will show the Trade Mark, Model Number and Version Number first, as follows:

```
ARI LINECHECK
510L          VER: X.X
```

The program will then recall the Memory and Step which was last executed.

4.3 Set Mode Screen

The settings screen will show parameter settings of the test that will be performed and the memory locations that they are stored in. This screen can be accessed after a test is aborted or after a pass condition by pressing the RESET button or after a test failure by pressing the RESET button twice. The test result will overwrite the Delay timer after a test is completed or when a failure occurs. The left side of the second line always indicates the Memory and Step that has been selected and an underbar character to the right of the step number indicates that the step has been connected to the next step in sequence. The display will show the underbar indicating step 1 is connected to step 2 as follows:

```
1.0 s      D 110.2V
M1-1_     G-L 2500µA
```

4.4 Reviewing Test Results

The test results from the first 16 tests that are executed can be reviewed by pressing the Enter/Review key. Successive key presses will continue advancing to the next result. The results of the last step in the process will be followed by the first step when scrolling through the results.

If four or more memories are connected together (more than an 16 step process) then only the first 16 steps executed in the process will be stored into the results memory. The results from the steps executed after the first 16 steps in the process will not be retrievable. Results can be reviewed at any time before the next test is executed. All 16 buffers are cleared at the start of the next test cycle.

5. Displayed Messages

5.1 Test In Process

After pressing the test button to initialize the test, the TEST light on the right side of the instrument will illuminate. The instrument will indicate the test is processing as follows:

T e s t 2 2 2 s 1 1 0 . 2 V
M 1 - 1 _ G - L 2 5 0 0 μ A

5.2 Abort

If the RESET button is pressed during the test cycle the test will be aborted and the display indicate that the test has been aborted as follows:

A b o r t D 1 1 0 . 2 V
M 1 - 1 _ G - L 2 5 0 0 μ A

5.3 Pass

When the test cycle has completed successfully without detecting any failures, you will hear a short audible beep to let you know the test has completed successfully. The display will also indicate that the test has passed as follows:

P a s s D 1 1 0 . 2 V
M 1 - 1 _ G - L 2 5 0 0 μ A

5.4 High Limit Failure

If the leakage current of the item under test exceeds the HI-Trip setting, the unit will indicate a failure at the end of the delay time by illuminating the FAIL indicator and activating the alarm. All relays will be deactivated to disable voltage to the DUT. The display will indicate a high limit failure as follows:

H I - F a i l D 1 1 0 . 2 V
M 1 - 1 _ G - L 2 5 0 0 μ A

To clear the failure light and alarm, press the RESET button. The alarm and light will be turned off but the display will continue to indicate the type of failure until a second reset is activated.

5.5 Low Limit Failure

If the leakage current of the item under test less than the LO-Trip setting, the unit will indicate a failure at the end of the delay time by illuminating the FAIL indicator and activating the alarm. All relays will be deactivated to disable voltage to the DUT. The display will indicate a low limit failure as follows:

L O - F a i l D 1 1 0 . 2 V
M 1 - 1 _ G - L 2 5 0 0 μ A

To clear the failure light and alarm, press the RESET button. The alarm and light will be turned off but the display will continue to indicate the type of failure until a second reset is activated.

5.6 Measuring Device Overload

This failure condition will interrupt the delay cycle. The delay time will not be completed because the measuring device overload failure is a failure that requires an immediate shutdown.

If the probes are applied to voltage that exceeds the maximum limit specified, the unit will indicate failure by illuminating the FAIL indicator and activating the alarm. All relays will be deactivated to disable voltage to the DUT. The display will indicate measuring device overload failure as follows:

MD-OVLD D	110.2V
M1-1_ G-L	>6000 μ A

5.7 Line Current Overload

This failure condition will interrupt the delay cycle. The delay time will not be completed because the line over-current failure is a failure that requires an immediate shutdown.

If the line current of the item under test exceeds the maximum limit of DUT current, the unit will indicate failure by illuminating the FAIL indicator and activating the alarm. All relays will be deactivated to disable voltage to the DUT. The display will indicate a line over-current failure as follows:

Line OC D	110.2V
M1-1_ G-L	2500 μ A

5.8 Line Voltage Overload

This failure condition will interrupt the delay cycle. The delay time will not be completed because the line over-voltage failure is a failure that requires an immediate shutdown.

If the line voltage of the DUT input exceeds the maximum limit of DUT voltage, the unit will indicate failure by illuminating the FAIL indicator and activating the alarm. All relays will be deactivated to disable voltage to the DUT. The display will indicate a line over-voltage failure as follows:

Line OV D	>300V
M1-1_ G-L	2500 μ A

6. Connection of Remote I/O

Two 9 pin “D” type connectors are mounted on the rear panel which provide REMOTE-INPUT-OUTPUT control and information. These connectors mate with standard 9 pin D-subminiature connector provided by the user. The output mates to a male (plug) connector while the input mates to a female (receptacle) connector. For best performance a shielded cable should be used. To avoid ground loops the shield should not be grounded at both ends of the cable. Suggested AMP part numbers for interconnecting to the Remote I/O are shown below.

205204-4	PLUG SHELL WITH GROUND INDENTS
205203-3	RECEPTACLE SHELL
745254-7	CRIMP SNAP-IN PIN CONTACT (for plug)
745253-7	CRIMP SNAP-IN SOCKET CONTACT (for receptacle)
745171-1	SHIELDED CABLE CLAMP (for either plug or receptacle)
747784-3	JACKSCREW SET (2)

Remote Interface Rear Panel:

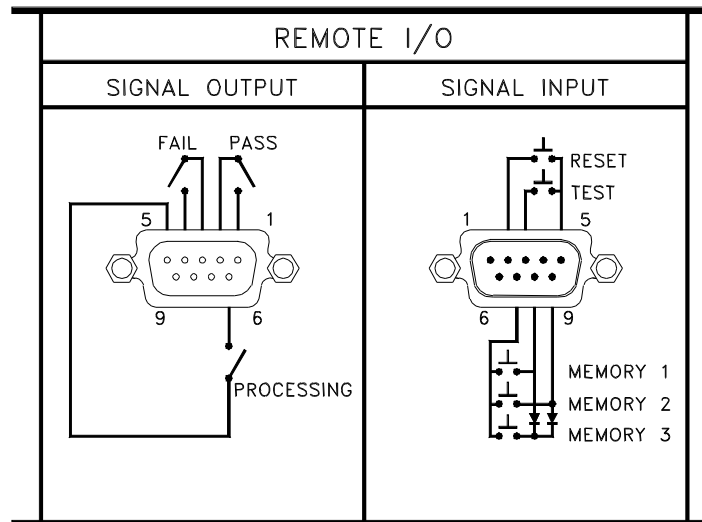

6.1 Signal Outputs on Remote I/O

The rear panel connector provides three output signals to remotely monitor PASS, FAIL, and PROCESSING conditions. The monitoring signals are provided by three normally open internal relays that switch on to indicate the current condition of the tester. These are normally open free contacts and will not provide any voltage or current. The ratings of the contacts are 1A / 250 VAC (0.5 ADC). The signal outputs are provided on the 9 pin female type D connector. Below is a listing that indicates what conditions activate each pin. When a terminal becomes active the relay closes thereby allowing the external voltage to operate an external device.

- Pins 1 and 2 provide the PASS signal.
- Pins 3 and 4 provide the FAIL signal.
- Pins 5 and 6 provide the PROCESSING signal.

The following describes how the relays operate for each test condition.

PROCESSING - The relay contact closes the connection between pin (5) and pin (6) while the instrument is performing a test. The connection is opened at the end of the test.

PASS - The relay contact closes the connection between pin (1) and pin (2) after detecting that the item under test passed all tests. The connection is opened when the next test is initiated or the reset function is activated.

FAIL - The relay contact closes the connection between pin (3) and pin (4) after detecting that the item under test failed any test. The connection is opened when the next test is initiated or the reset function activated.

6.2 Signal Inputs of Remote I/O and Memory Programs

The LINECHEK remote connector enables remote operation of the TEST and RESET functions or allows the operator to select one of three pre-programmed tests. A signal input is also provided to indicate that a Withstand test is processing. When the remote function is (ON) the test switch on the front panel will be disabled to prevent a test from being activated through the test switch. A normally open momentary switch can then be wired across pins 3 and 5 to allow remote operation of the TEST function. A normally open momentary switch can also be wired across pins 2 and 5 which allows remote operation of the RESET function. For safety, the front panel RESET switch remains active even when a remote reset switch is connected so that high voltage can be shut down from either location.

The LINECHEK also allows access to three MEMORY PROGRAMS through the remote control connector. This gives the user the capability to quickly change parameters and initiate a test remotely. The LINECHEK basically operates in a PLC mode by responding to simple switch or relay contact closures. The built in memory programs of the instrument are used to accomplish this. Three internal memory programs can be accessed. By connecting terminals 7, 8 and 9 in different combinations the user can select the correct memory program.

WARNING

ACTIVATING MEMORY PROGRAM FUNCTIONS THROUGH THE REMOTE CONNECTOR, SELECTS THE PROGRAM AND STARTS THE TEST WHICH IS PRE-PROGRAMMED INTO THAT MEMORY.

CAUTION

DO NOT CONNECT VOLTAGE OR CURRENT TO THE SIGNAL INPUTS, THIS COULD RESULT IN DAMAGE TO THE CONTROL CIRCUITRY.

MEMORY 1 - Momentarily connecting terminal 7 to 8 signals the instrument to immediately begin the test program that is stored in memory 1.

MEMORY 2 - Momentarily connecting terminal 7 to 9 signals the instrument to immediately begin the test program that is stored in memory 2.

MEMORY 3 - Momentarily connecting terminal 7 to terminals 8 and 9 signals the instrument to immediately begin the test program that is stored in memory 3.

7. Bus Remote Interface GPIB / RS-232

This section provides information on the proper use and configuration of bus remote interface. The GPIB (IEEE-488) remote interface is standard on model 510L but the RS-232 interface option can be substituted for the GPIB interface. The RS-232 interface also uses the same command list as the GPIB with the exception of the SRQ functions. Please refer to the Option section of this manual for details on the 510L options.

7.1 A Brief History of IEEE-488....

Hewlett-Packard designed in 1965 the Hewlett-Packard Interface Bus (HP-IB) to connect their line of programmable instruments to computers. This bus had high transfer rates (nominally 1 Mbytes/s), and thus quickly gained acceptance. Later, it was accepted as the IEEE Standard 488-1975 and has since evolved into ANSI/IEEE Standard 488.1-1987.

IEEE-488 has expanded over the years and is used with many more types of computers and instruments than just HP. Because of this it is usually referred to as the General Purpose Interface Bus, (GPIB).

7.2 GPIB Messages

There are typically two types of messages that GPIB devices use to communicate with other interconnected GPIB devices;

Interface messages: often called commands or command messages and Device dependent messages often called data or data messages.

Data Messages: contain information such as programming instructions or measurement results. Command Messages perform functions such as initializing the bus and addressing and unaddressing devices.

7.3 Functions

A GPIB device can be a Listener, Talker and/or Controller. A Talker sends data messages to one or more Listeners, which receive data. A Controller manages the information flow on the GPIB by sending commands to all devices. The GPIB bus is much like a computer bus except a computer has circuit cards connected via a backplane and the GPIB has stand alone devices connected via a cable.

7.4 Signals and Lines

The GPIB consists of 16 signal lines and 8 ground-return or shield drain lines. The 16 signal lines are grouped into 8 data lines, 3 handshake lines and 5 interface management lines.

Data Lines: The eight data lines, DI01 through DI08 carry data and command messages. The 7-bit ASCII or ISO code set is used and the eighth bit DI08 is unused.
Handshake Lines: The transfer of message bytes between devices is done via three

asynchronously control lines. Referred to as three-wire interlocked handshake. This guarantees that message bytes on the data lines are sent and received without transmission error.

NRFD (not ready for data) indicates when a device is ready or not ready to receive a message byte.

NDAC (not data accepted) indicates when a device has or has not accepted a message byte.

DAV (data valid) tells when the signals on the data lines are stable (valid) and can be accepted safely by devices.

Interface Management Lines: Five lines are used to manage the flow of information across the interface.

ATN (attention) ATN is driven true by the controller when it uses the data lines to send commands, and drivers ATN false when a Talker can send data messages.

IFC (interface clear) IFC is driven by the system controller to initialize the bus and become CIC.

REN (remote enable) The REN line is driven by the controller which is used to place devices in remote or local program mode.

SRQ (service request) The SRQ line can be driven by any device to asynchronously request service from the Controller.

EOI (end or identify) This line has two purposes- the Talker uses this line to mark the end of a message string, and the Controller uses it to tell devices to identify their response in a parallel poll.

7.5 GPIB Connector

Connection is usually accomplished with a 24-conductor cable with a plug on one end and a connector at the other end. Devices may be connected in a linear, star or a combination configuration.

The standard connector is the Amphenol or Cinch Series 57 Microribbon or AMP CHAMP type. The GPIB uses negative logic with standard transistor-transistor logic (TTL) levels. When DAV is true, for example, it is a TTL low level (≤ 0.8 V), and when DAV is false, it is a TTL high level (≥ 2.0 V).

Restrictions and Limitations on the GPIB

A maximum separation of 4 m between any two devices and an average separation of 2 m over the entire bus. A maximum total cable length of 20 m.

No more than 15 device loads connected to each bus, with no less than two-thirds powered on.

Note: A bus extender which is available from numerous manufacturers is available to overcome these limitations.

7.6 GPIB Address

Each device on the GPIB (IEEE-488) interface must have a unique address. You can set the address of the 510L to any value between 0 and 30. The address is set to 5 when the instrument is shipped from the factory. The address can only be set from the front panel. The address is stored in non-volatile memory and does not change when the power has been off or after a remote interface reset.

7.7 Interface Functions

The capability of a device connected to the bus is specified by its interface functions. These functions provide the means for a device to receive, process, and send messages over the bus. The interface functions are listed in the chart below. All functions may be controlled over the bus except input voltage which is Selectable on the rear panel.

GPIB INTERFACE FUNCTIONS

IEEE-488 INTERFACE	Complete handshake capability Talker/Listener functions Service request capability No remote/local capability No parallel poll capability No device clear capability No device trigger capability No controller capability 3 state driver
CONTROLLABLE ITEMS	Test/Reset control Setting of test status/parameters for test LCD Display Reading Test Results Reading
DATA CODES	ASCII
DELIMITER	CR + LF (+ EOI)

7.8 RS-232 Interface

This interface may be substituted for the standard GPIB interface on model 510L. This interface provides all of the control commands of the GPIB interface with the exception of the SRQ commands. All commands can be found in the command list portion of the Operation section 7.9 of this manual.

The RS-232 cabling should be configured as follows for a 9 pin serial port interface:

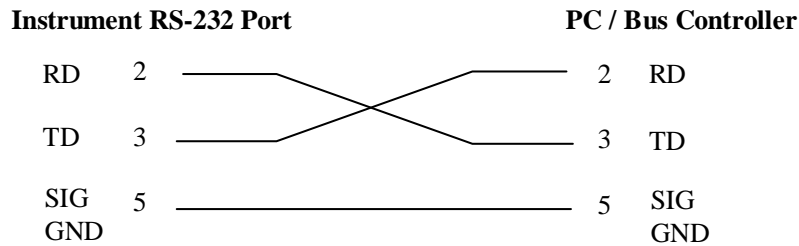

The COM port should have the following configuration. 9600 baud, 8 data bits, 1 stop bit, no parity. This interface does not support XON/XOFF protocol or any hardware handshaking. The controller should be configured to ignore the handshaking lines DTR (pin 4), DSR (pin 6) CTS (pin 8) and RTS (pin 7). If the port can not be configured through software to ignore the lines then the handshake lines should be jumpered together in two different sets. Pins 4 and 6 jumpered together and pins 7 and 8 jumpered together at the controller end of the cable.

When sending command over the RS232 bus the instrument will echo a response string identical to the string that was sent if the transfer was recognized and accepted by the instrument. This allows for software handshaking, to monitor and control data flow. If there is an error with the command string that is sent, the instrument will respond with 15h or the “NAK” ASCII control code. When requesting data from the instrument, it automatically send the data to the controller input buffer. The controller input buffer will accumulate data being sent from the instrument including the echo response string, until it is read by the controller.

7.9 510L GPIB Interface Command List

When the GPIB controller sends a correct command beginning with an “S” or “F” the instrument will echo back the identical command string. A GPIB read command must be sent after the command string to view this echo response.

If an error occurs when a command is sent, or the instrument does not recognize the command then the instrument will respond with a value of ASCII “NAK” (15hex), after the read command is sent. Each string should be terminated by ASCII <LF> and <CR>. ALL commands are case sensitive.

7.9.1 Parameter Selection Commands

The following commands are used to toggle ON/OFF functions or menu selection items. No other values or additional parameters are needed to execute these commands.

System Settings and Commands	
Command	Function
FA	Test
FB	Reset
FQ	Connect On
FR	Connect Off
FS	Fail Stop On
FT	Fail Stop Off
FY	Single Step On
FZ	Single Step Off

Line Configuration Settings			
Command	Configuration		
	NEUTRAL	REVERSE	GROUND
SL1	Fault	Normal	Fault
SL2	Fault	Fault	Fault
SL3	Fault	Normal	Normal
SL4	Fault	Fault	Normal
SL5	Normal	Normal	Fault
SL6	Normal	Fault	Fault
SL7	Normal	Normal	Normal
SL8	Normal	Fault	Normal

Probe Configuration Settings	
Command	Configuration
SP1	Measurement from ground to line
SP2	Measurement from Probe-HI to line
SP3	Measurement from Probe-HI to Probe-LO

Measuring Device Settings	
Command	Configuration
SDA	Set measuring device circuit A for UL544 non patient care
SDB	Set measuring device circuit B for UL544 patient care
SDC	Set measuring device circuit C for UL2601, IEC601
SDD	Set measuring device circuit D for UL1563
SDE	Set measuring device circuit E for UL3101,UL1950
SDF	Set measuring device circuit F for external

7.9.2 Parameter Data Input Commands

The following commands require a numeric value to follow the command string.

Parameter Setting			
Command	Function	Value	Unit
S5	Memory Select	1 - 50	Integer
S6	Step Select (1-8)	1 - 8	Integer
SC	Setting of Current High Trip Value	1 - 6000	μ A
SB	Setting of Current Low Trip Value	1 - 6000	μ A
ST	Setting of Delay Time	0.0 - 999.9	Seconds

7.9.3 Data Retrieval Commands

The following commands are used to retrieve information from the LINECHEK. After the command is sent a GPIB read command must follow to retrieve the data from the instrument in GPIB operation. In RS-232 operation the LINECHEK will automatically send the results to the data buffer at the controller.

Query Commands		
Command	Description	Bytes Returned
?n n=1-16	Returns the results of the test that was executed on the nth step from the start of the test sequence.	40 bytes
?K	LCD READ used for active polling if the active LCD display during or after the test.	40 bytes
?D	Read the status of the Reset input	1 byte 0 = OFF 1 = ON

The “n” within the read buffer command ?n represents the number of the test in a sequence of tests and not the actual step number. The test number starts with 1 as the first test performed. For example, if three steps were executed as a sequence, using steps 5, 6 and 7, the results from step 5 will be retrieved from the 1st buffer using the ?1 command not ?5.

7.9.4 GPIB Service Request

SRQ Configuration Settings	
F0	Enable "All Pass" SRQ
F1	Disable "All Pass" SRQ
F2	Enable "Fail" SRQ
F3	Disable "Fail" SRQ
F4	Enable "Abort" SRQ
F5	Disable "Abort" SRQ
F6	Enable "Error Command" SRQ
F7	Disable "Error Command" SRQ

The service request capability is not available with the RS-232 interface. The service request status byte can be read from the instrument only after one or more of the service request functions have been enabled. The status byte bit assignments are as follows.

BIT	7	6	5	4	3	2	1	0
Function	na	RQS	na	na	ERROR	ABORT	FAIL	PASS

The bit will be active or 1 when the SRQ function has been enabled and the condition is true. Bit 6 is the RQS bit and will be active when the instrument has detected that an enabled SRQ has been met and therefore has requested service. Bit 4,5, and 7 are not used and will be set to false or 0 for all status reads.

After the status byte has been read from the instrument the RQS bit will be cleared to 0 and the remaining bits will be unchanged. The remaining bit will be unchanged until the next time service is requested.

For example, after the All Pass SRQ has been enabled, when the test(s) have finished with pass indications the instrument will set the hardware SRQ line and output the status byte of 41 hex. This means that bit 6 and bit 0 are set to a value of 1. After reading the status byte the status byte value will change to 01 hex and remain at 01 hex until next time service is requested.

7.10 Example of Communicating Over the GPIB bus

To write commands over the GPIB bus you must enter the code that is specific to the software language you are using. Then follow the example below:

To set the High Current Trip across the GPIB bus at 1000 μ A do the following. First select the memory and step that you wish to change Then send the string "**SC 1000**": This tells the instrument to set the High Current Trip to 1000 μ A. A string is a list of ASCII characters, octal or hex bytes or special symbols, enclosed in double quotes.

If you wish to set the Delay time of the test across the GPIB bus at 10 seconds, do

the following, send the string “**ST 10.00**”. This tells the instrument to set the Delay Time at 10.00 seconds for the Memory and step that has been selected.

To read the 2 x 20 display, first send the string “**?K**” then send the GPIB command to read 40 bytes. The instrument will send 40 bytes, one byte for each character on the display, including spaces.

7.11 Non Volatile Memory

The instrument saves each parameter in non-volatile memory when the parameter is changed. The non-volatile memory has a limited write cycle life, therefore there is a special volatile memory location that is available for programmers who wish to send all parameters before executing each test. Memory 9, step 8 is the memory location that will **NOT** write the parameter to non-volatile memory. Settings written to this location from GPIB mode will be lost when power is shut down. Parameter changes to this location is unlimited and will not effect the life of the internal non-volatile memory chip.

FOR MORE INFORMATION ON IEEE (GPIB) PLEASE CONTACT:

The Institute of Electrical and Electronic Engineers, Inc.
345 East 47th Street,
New York, NY 10017

(1-212-705-7018 (Communications Society of IEEE)

Internet: www.ieee.org

Model 510L OPTIONS

Introduction

This section contains a list and descriptions of available factory installed options at the time of this printing. The list of options contains an option code number that can be referenced on the rear panel of the unit.

Option Label

On the rear panel of the instrument you will find a label that contains the option code.

For example your options code would appear as follows:

fitted with option 01 OPT: 01
 fitted with option 01 and 02..... OPT: 0102

510L Options

Option List

Code	Description
01	RS232 Interface
02	TBD

01 RS232 Interface

This option may be substituted for the standard GPIB interface. This option provides all of the command control of the GPIB interface with the exception of the SRQ commands. All commands can be found in the GPIB portion of the Operation section of this manual.

The RS232 cabling should be configured as follows for a 9 pin serial port interface:

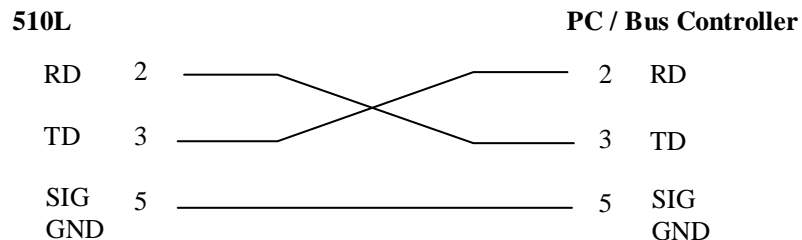

The COM port should have the following configuration. 9600 baud, 8 data bits, 1 stop bit, no parity. This interface does not support XON/XOFF protocol or any hardware handshaking. The controller should be configured to ignore the handshaking lines DTR (pin 4), DSR (pin 6) CTS (pin 8) and RTS (pin 7). If the port can not be configured through software to ignore the lines then the handshake lines should be jumpered together in two different sets. Pins 4 and 6 jumpered together and pins 7 and 8 jumpered together at the controller end of the cable.

When sending command over the RS232 bus the 510L will echo a response string identical to the string that was sent if the transfer was recognized and accepted by the instrument. This allows for software handshaking, to monitor and control data flow. If there is an error with the command string that is sent, the instrument will respond with 15h or the “NAK” ASCII control code. When requesting data from the instrument, it automatically sends the data to the controller input buffer. The controller input buffer will accumulate data being sent from the instrument including the echo response string, until it is read by the controller.

SECTION 2
SERVICE MANUAL

CALIBRATION PROCEDURES

This instrument has been fully calibrated at the factory in accordance to our published specifications. It has been calibrated with standards traceable to the National Institute Standards & Technology (NIST). You will find in this manual a copy of the "Certificate of Calibration". It is recommended that you have this instrument recalibrated and a safety check done at least once per year. AR recommends you use "Calibration Standards" that are NIST traceable, or traceable to agencies recognized by NIST to keep this instrument within published specifications.

End user metrology standards or practices may vary. These metrology standards determine the measurement uncertainty ratio of the calibration standards being used. Calibration adjustments can only be made in the Calibration mode and calibration checks or verifications can only be made while operating in Test mode.

Press and hold the calibration key on the rear panel with a pen, pencil or small screw driver while powering ON the 510L. The 510L enters maintenance mode after the power on sequence is complete. The initial screen will show:

Maintenance mode
SETUP for menu

Use the SETUP key to scroll through the menu. The selections are Calibration, EEPROM Initialization, and Restore Default MD:F.

1.1 Calibration Initialization

Press the SETUP key, the program will advance to the Calibration selection mode. The display will show:

Calibrate 510L
Press CAL button

Please refer to section 2. for the actual calibration procedure.

1.2 EEPROM Initialization

Press the SETUP key, the program will advance to the EEPROM Initialization selection mode. The display will show:

Initiate EEPROM
Press ENTER

The EEPROM initialization will restore all memory locations with default calibration data. All previous calibration data will be lost. Press the ENTER key and the display will prompt you to continue with the EEPROM initialization as follows:

Erase Cal. (Y/N)?
Y= ENTER N= EXIT

Press the ENTER key to begin the initialization. If the EXIT key is pressed you will return to the maintenance menu. When the initialization has started the display will show:

Initializing...
Please wait

1.3 Restore Measuring Device F Default

Press the SETUP key, the program will advance to the MD:F default restore mode. The display will show:

Restore MD:F
Press ENTER

Press the ENTER key to restore the device F default value to 1 K Ω . The display will momentarily display the default value and return to the previous screen. The display will show:

Restore MD:F
MD : F = 1000

This function is used to restore the default value before verifying the bandwidth of the leakage current “voltmeter.” If measuring device F has never been calibrated using a new measuring device circuit then you may not need to perform this default restore. The default setting from the factory is 1 K Ω .

The calculation of the displayed leakage current will use 1000 Ω for R in the calculation of $V/R=I$ where I is the leakage current displayed and V is voltage across the measuring device (MD). The probe should be selected to P_H-P_L and the MD selected to F. When an external frequency generator is applied to the probe inputs then the current display will be equal to Voltage generator/1000. The readings can then be correlated to verify the voltmeter bandwidth. Since the voltage is being applied directly across the MD voltmeter amplifier inputs it is not necessary to actually install a 1K Ω resistor to the external MD:F inputs. However, to complete the circuit a jumper should be applied between the two red terminals V and I of the external MD:F inputs.

2. Calibration

Press the calibration button on the rear panel when the display shows:

Calibrate 510L
Press CAL button

A complete calibration includes:

1. Meter auto null
2. Meter gain calibration
3. Meter ratio auto check
4. DUT voltmeter calibration
5. Measuring Device calibration

Procedure 1 and 3 are internal and automatic. Procedure 2, 4, and 5 require the following equipment:

1. AC 120V source with Standard AC Voltage meter
2. Standard Current Meter, 10mA range
3. 1K Ω 1/4W Resistor
4. DC source with 2.2V and 3.1V capability

2.1 Meter Auto Zero

Press the SETUP key, the program will advance to the Meter Auto Zero calibration. The display will show:

Meter Auto Zero
TEST to start

Make sure that Probe HI and LO are shorted and that the DUT power connection have been disconnected. There should not be any DUT input voltage during the Auto Zero calibration.

Press TEST and wait for the 510L to check the zero of each range. The first line shows the range. Two numbers appear on the second line. The number on the left (NU=xx) is the auto-null DAC setting that minimizes the RMS to DC converter output offset. The number on the right (OS=xx) is the residual offset after the auto-null. This offset is subtracted in software to make the reading zero when there is no input. No user adjustable parameters are necessary. The screens will be displayed as follows as the auto zero is executed.

Auto zero . . .
takes ~ 90 sec.

Range 0 null . . .
NU = XX , OS = XX

Range 1 null . . .
NU = XX , OS = XX

Range 2 null . . .
NU = XX , OS = XX

Range 3 null . . .
NU = XX , OS = XX

Range 4 null . . .
NU = XX , OS = XX

DUT voltage null . . .
OS = XX , DONE.

2.2 Meter Gain Calibration

Press the SETUP key, the program will advance to the meter gain calibration. The display will show:

ENTER meter gain
calibration

Apply 2.2VDC between Probe HI and Probe LO, then press ENTER. 510L displays the voltage it measures. The display will show:

XXXX mV
Enter probe mV

Key in the correct voltage as necessary. The ENTER key enters the number into calibration data and refreshes the voltage display. The EXIT key exits without changing calibration and returns the menu back to the previous screen.

2.3 Meter Range Auto Calibration

Press the SETUP key, the program will advance to the Ratio Check calibration. The display will show:

Ratio check
TEST to start

Press the Test button to start the process. In this procedure, 510L uses the gain calibration data from procedure 2 to calibrate other ranges. It is fully internal and automatic. There is a dedicated DAC for the ratio check. During the ratio check, 510L displays the raw ADC readings. The screens will be displayed as follows as the Ratio Check is executed.

Auto gain ratio
takes ~ 25 sec.

RAN1: XXXX
RAN0: XXXX

RAN1: XXXX
RAN2: XXXX

RAN2: XXXX
RAN3: XXXX

RAN3: XXX
RAN4: XXXX

2.4 DUT Voltmeter Calibration

Press the SETUP key, the program will advance to the AC voltage calibration. The display will show:

ENTER AC Voltage
calibration

This is similar to the gain calibration where a known voltage source is applied to the DUT power input. Apply 60Hz, 120 V rms to the DUT power input. Then press the ENTER key. The 510L shows the measured voltage.

XXX.X V
Enter Line Volt

Key in the correct voltage then press the ENTER key. The voltage reading will be updated. When the calibrated value is correct press the EXIT key to return to the previous screen.

2.5 Measuring Device Calibration

Press the SETUP key, the program will advance to the MD circuit calibration. The display will show:

ENTER MD:A
calibration

The last five calibration items are to calibrate the MD resistor values. Connect a DC voltage source in series with 1K resistor, a current meter and the probe input terminal (Probe HI to Probe LO). The voltmeter should be set to 3.1V DC. Press the ENTER key. There will be a short pause while the MD circuit is configured and a

current reading is taken, and then the display will show:

MD:A, I= XXXX μ A Enter probe μ A
--

Enter the reading of current meter and press the ENTER key. The data will be saved and returns to the same screen with the new current reading. The value can then be re-entered if necessary, or press the EXIT key when the calibration is acceptable.

Press the SETUP key again and the MD will advance to MD:B. The display will show:

ENTER MD:B calibration

Press the Enter Key the display will show:

MD:B, I= XXXX μ A Enter probe μ A
--

This process continues and is the same for all Measuring Devices A through F.

2.6 Finished

Once all the calibration procedures are complete, then press the EXIT key to return to the Calibration Main Menu. Press the EXIT key a second time to return to normal operation mode. The Set screen will show the settings of the test that is ready to be executed. The instrument is now ready to perform any calibration verification or testing procedures.

Model 510L Replacement Parts List

Rev. G 06-20-06 ECO 5173-4

Part Number	Qty.	Reference Designator	Description
37515	1	CSW-01	PCB Assembly Input Protection Board
37550	1	CKB-01	PCB Assembly Keypad Board
38140	1	7620A	PCB Assembly Analog Control Board
38067	1	7620D	PCB Assembly Digital Control Board
38141	1	7611S	PCB Assembly Switch Board
37745	1	CGP-03	PCB Assembly GPIB Interface Board
37554	1	-	LCD Display 16 x 2 Characters
38047	1	-	Connector, Input Cable Kit, Military
38133	1	-	Connector, Output Cable Kit
38134	1	-	Connector, Panel Output Receptacle Kit
38042	1	-	Receptacle, 3-pin Male, Military
35999	8	-	Connector Black Banana Jacks
37571	1	-	Earth Connector
37557	1	-	Reset Switch, Red
37556	1	-	Test Switch, Green
37555	1	-	Power Switch 2P 10A/250V
37943	1	-	Transformer Input
37923	1	-	Fuse 250V 2A Slow Blow 20mm
37781	1	-	Fuse Holder 20mm
38101	1	-	Feet Kit Plastic without Rubber Inserts
38102	4	-	Rubber Insert
38793	2	-	2U Rack Mount Bracket
38794	2	-	2U Rack Mount Handle
33189	1	-	Input Power Cable 10A/7Ft.
02100A-13	2	-	Probe Cables
38577	1	-	Adapter Box

SCHEMATIC INDEX

Drawing Number	Description	Reference Designator	Pages
S00510L	Wiring Diagram	-	1
S37515	Input Protection Board	CSW-01	1
S37935	Analog Control Board	7620A	3
S37936	Digital Control Board	7620D	3
S37976	Switch Board	7611S	1
S37550	Keypad Board	CKB-01	1
S37745	GPIB Interface Board	CGP-03	1
S37814	RS232 Interface Board	RS232	1