



Advanced Test Equipment Rentals
www.atecorp.com 800-404-ATEC (2832)

CW-P SERIES ***PROGRAMMABLE*** ***AC POWER SOURCE***

Operation Manual

This manual covers models:

CW 801P
CW 1251P
CW 2501P
CW 801P-H
CW 1251P-H
CW 2501P-H
CW 801P-V
CW 1251P-V
CW 2501P-V



Contact Information

Telephone: 800 733 5427 (toll free in North America)

858 450 0085 (direct)

Fax: 858 458 0267

Email:

Domestic Sales: domorders.sd@ametek.com

International Sales: intlorders.sd@ametek.com

Customer Service: service.ppd@ametek.com

Web: www.programmablepower.com

Offered to you with pride by

The CW Development Team

Ron Schell
 Michael D. Dyer
 Debra Wilson
 Sue Messerli
 Bob Miller
 Tom Williams
 C. Holmes
 Immanuel K.L. Kipuri
 Mark Zeman
 Jack Williamson
 Rebecca Hart
 J.M. Sarff
 Norm Rowland
 Steve Hance
 Bob
 Carl
 Donna Ackerman
 Jan King
 Robert Fisher
 Laurie Chance
 Zoe Baumert
 Jim Reese
 Tom Thomas
 Robin Sullivan
 Larry Harty
 Ray Daniel
 Dan Kaylaund
 George Lopsy
 Steve Dunleavy
 But
 Ray
 Steve
 Alf Amargosa
 Hughman Monaghan

About AMETEK

AMETEK Programmable Power, Inc., a Division of AMETEK, Inc., is a global leader in the design and manufacture of precision, programmable power supplies for R&D, test and measurement, process control, power bus simulation and power conditioning applications across diverse industrial segments. From bench top supplies to rack-mounted industrial power subsystems, AMETEK Programmable Power is the proud manufacturer of Elgar, Sorensen, California Instruments and Power Ten brand power supplies.

AMETEK, Inc. is a leading global manufacturer of electronic instruments and electromechanical devices with annualized sales of \$2.5 billion. The Company has over 11,000 colleagues working at more than 80 manufacturing facilities and more than 80 sales and service centers in the United States and around the world.

Trademarks

AMETEK is a registered trademark of AMETEK, Inc.

Other trademarks, registered trademarks, and product names are the property of their respective owners and are used herein for identification purposes only.

Notice of Copyright

CW-P Series Programmable AC Power Source, Operation Manual © 2010 AMETEK Programmable Power, Inc. All rights reserved.

Exclusion for Documentation

UNLESS SPECIFICALLY AGREED TO IN WRITING, AMETEK PROGRAMMABLE POWER, INC. ("AMETEK"):

- (a) MAKES NO WARRANTY AS TO THE ACCURACY, SUFFICIENCY OR SUITABILITY OF ANY TECHNICAL OR OTHER INFORMATION PROVIDED IN ITS MANUALS OR OTHER DOCUMENTATION.
- (b) ASSUMES NO RESPONSIBILITY OR LIABILITY FOR LOSSES, DAMAGES, COSTS OR EXPENSES, WHETHER SPECIAL, DIRECT, INDIRECT, CONSEQUENTIAL OR INCIDENTAL, WHICH MIGHT ARISE OUT OF THE USE OF SUCH INFORMATION. THE USE OF ANY SUCH INFORMATION WILL BE ENTIRELY AT THE USER'S RISK, AND
- (c) REMINDS YOU THAT IF THIS MANUAL IS IN ANY LANGUAGE OTHER THAN ENGLISH, ALTHOUGH STEPS HAVE BEEN TAKEN TO MAINTAIN THE ACCURACY OF THE TRANSLATION, THE ACCURACY CANNOT BE GUARANTEED. APPROVED AMETEK CONTENT IS CONTAINED WITH THE ENGLISH LANGUAGE VERSION, WHICH IS POSTED AT WWW.PROGRAMMABLEPOWER.COM.

Date and Revision

March 2011 Revision J

Part Number

M161691-01



Contact Information

Telephone: 800 733 5427 (toll free in North America)
858 450 0085 (direct)
Fax: 858 458 0267
Email: sales@programmablepower.com
service@programmablepower.com
Web: www.programmablepower.com

This page intentionally left blank.

Important Safety Instructions

Before applying power to the system, verify that your product is configured properly for your particular application.

 WARNING	Hazardous voltages may be present when covers are removed. Qualified personnel must use extreme caution when servicing this equipment. Circuit boards, test points, and output voltages also may be floating above (below) chassis ground.
 WARNING	The equipment used contains ESD sensitive ports. When installing equipment, follow ESD Safety Procedures. Electrostatic discharges might cause damage to the equipment.

Only *qualified personnel* who deal with attendant hazards in power supplies, are allowed to perform installation and servicing.

Ensure that the AC power line ground is connected properly to the Power Rack input connector or chassis. Similarly, other power ground lines including those to application and maintenance equipment *must* be grounded properly for both personnel and equipment safety.

Always ensure that facility AC input power is de-energized prior to connecting or disconnecting any cable.

In normal operation, the operator does not have access to hazardous voltages within the chassis. However, depending on the user's application configuration, **HIGH VOLTAGES HAZARDOUS TO HUMAN SAFETY** may be normally generated on the output terminals. The customer/user must ensure that the output power lines are labeled properly as to the safety hazards and that any inadvertent contact with hazardous voltages is eliminated.

Guard against risks of electrical shock during open cover checks by not touching any portion of the electrical circuits. Even when power is off, capacitors may retain an electrical charge. Use safety glasses during open cover checks to avoid personal injury by any sudden component failure.

Neither AMETEK Programmable Power Inc., San Diego, California, USA, nor any of the subsidiary sales organizations can accept any responsibility for personnel, material or inconsequential injury, loss or damage that results from improper use of the equipment and accessories.

SAFETY SYMBOLS



WARNING
Risk of Electrical Shock



CAUTION
Refer to Accompanying Documents



Off (Supply)



Direct Current (DC)



Standby (Supply)



Alternating Current (AC)



On (Supply)



Three-Phase Alternating Current



Protective Conductor Terminal



Earth (Ground) Terminal



Fuse



Chassis Ground

**Product Family: CW801P, CW1251P, CW2501P, CW801P-H, CW1251P-H,
CW2501P-H, CW801P-V, CW1251P-V, CW2501P-V**

Warranty Period: One Year

WARRANTY TERMS

AMETEK Programmable Power, Inc. ("AMETEK"), provides this written warranty covering the Product stated above, and if the Buyer discovers and notifies AMETEK in writing of any defect in material or workmanship within the applicable warranty period stated above, then AMETEK may, at its option: repair or replace the Product; or issue a credit note for the defective Product; or provide the Buyer with replacement parts for the Product.

The Buyer will, at its expense, return the defective Product or parts thereof to AMETEK in accordance with the return procedure specified below. AMETEK will, at its expense, deliver the repaired or replaced Product or parts to the Buyer. Any warranty of AMETEK will not apply if the Buyer is in default under the Purchase Order Agreement or where the Product or any part thereof:

- is damaged by misuse, accident, negligence or failure to maintain the same as specified or required by AMETEK;
- is damaged by modifications, alterations or attachments thereto which are not authorized by AMETEK;
- is installed or operated contrary to the instructions of AMETEK;
- is opened, modified or disassembled in any way without AMETEK's consent; or
- is used in combination with items, articles or materials not authorized by AMETEK.

The Buyer may not assert any claim that the Products are not in conformity with any warranty until the Buyer has made all payments to AMETEK provided for in the Purchase Order Agreement.

PRODUCT RETURN PROCEDURE

1. Request a Return Material Authorization (RMA) number from the repair facility (**must be done in the country in which it was purchased**):
 - **In the USA**, contact the AMETEK Repair Department prior to the return of the product to AMETEK for repair:
Telephone: 800-733-5427, ext. 2295 or ext. 2463 (toll free North America)
858-450-0085, ext. 2295 or ext. 2463 (direct)
 - **Outside the United States**, contact the nearest Authorized Service Center (ASC). A full listing can be found either through your local distributor or our website, www.programmablepower.com, by clicking Support and going to the Service Centers tab.
2. When requesting an RMA, have the following information ready:
 - Model number
 - Serial number
 - Description of the problem

NOTE: Unauthorized returns will not be accepted and will be returned at the shipper's expense.

NOTE: A returned product found upon inspection by AMETEK, to be in specification is subject to an evaluation fee and applicable freight charges.

CONTENTS

SECTION 1 INTRODUCTION.....	0-1
SECTION 2 SPECIFICATIONS	1-1
2.1 Output.....	1-1
2.2 Measurement	1-3
2.3 Input	1-5
2.4 Protection	1-6
2.5 Rear Panel Connections.....	1-6
2.6 General.....	1-6
2.7 Options and Accessories.....	1-7
SECTION 3 INSTALLATION.....	2-1
3.1 Unpacking	2-1
3.2 Wire Gauge Selection	2-2
3.3 Mounting Instructions	2-5
3.4 Cooling	2-5
3.5 Power In Connections	2-10
3.5.1 Single-Phase Supply Connections.....	2-10
3.5.2 Split-Phase Supply Connections 120-0-120V	2-11
3.5.3 Three-Phase Supply Connections	2-11
3.6 Power Out Connections.....	2-12
3.7 Sense Connections	2-13

- 3.8 Remote Control Signal2-15
 - 3.8.1 Analog Amplitude Control.....2-15
 - 3.8.2 Lock to External Frequency Source2-15
 - 3.8.3 Sync Output Pulse.....2-16
- 3.9 Master/Slave Configurations2-16
 - 3.9.1 Setup for Single–Phase, Two Units.....2-17
 - 3.9.2 Setup for Three–Phase, Two Units per Phase2-20

- SECTION 4 OPERATION 3-1**
- 4.1 CW Front Panel Controls and Indicators3-1
- 4.2 Front Panel Overview.....3-4
- 4.3 Power Up3-5
- 4.4 Programmed Frequency Steps4-6

- SECTION 5 PROGRAMMING 4-1**
- 5.1 Programming the CW Via the Front Panel.....4-1
 - 5.1.1 VOLTAGE/POWER Section.....4-2
 - 5.1.2 CURRENT/FREQUENCY Section.....4-2
- 5.2 Measurement Operations4-2
 - 5.2.1 Supply Measurements on the Left Display4-2
 - 5.2.2 Supply Measurements on the Right Display4-3
- 5.3 Menu Operations4-4
 - 5.3.1 Self Test4-5
 - 5.3.2 Set GPIB Port.....4-5
 - 5.3.3 Specify Current Limit Type4-6
 - 5.3.4 Specify Shutdown Delay.....4-6
 - 5.3.5 Specify Program Keys Locked Mode4-6
 - 5.3.6 Store Present Machine Settings4-6
 - 5.3.7 Recall Machine Settings4-7
 - 5.3.8 Specify Relay State After Power Up Initialization4-7
 - 5.3.9 Clock Direction4-7
 - 5.3.10 Analog Input State.....4-7

5.3.11	RMS Voltage Loop	4-8
5.3.12	Phase A Offset	4-8
5.3.13	Phase B Offset	4-8
5.3.14	Phase C Offset	4-8
5.3.15	Slave Channel	4-8
5.3.16	Slave Address	4-8
5.3.17	Slave Configuration	4-8

SECTION 6 MAINTENANCE.....5-1

6.1	Periodic Service.....	5-1
6.2	Fuse Replacement	5-1

LIST OF FIGURES

Figure 1–1	ContinuousWave Front Panel (Model CW 801P)	1-1
Figure 3–1	Slide Mounting.....	3-5
Figure 3–2	Mounting Dimensions, Front and Rear Views (CW 801P and CW 1251P)	3-6
Figure 3–3	Mounting Dimensions, Front and Rear Views (CW 2501P).....	3-7
Figure 3–4	Mounting Dimensions, Top and Side Views (CW 801P and CW 1251P)	3-8
Figure 3–5	Mounting Dimensions, Top and Side Views (CW 2501P)	3-9
Figure 3–6	Input Power Connections	3-10
Figure 3–7	Output Power Connections.....	3-12
Figure 3–8	Output Voltage Sensing Configuration	3-13
Figure 3–9	Sense Connections	3-14
Figure 3–10	M/S IN Connector	3-15
Figure 3–11	Wiring Diagram for One Phase, Master/Slave Configuration ..	3-17
Figure 3–12	Wiring Diagram for Three Phase, Master/Slave Configuration	3-20
Figure 4–1	Front Panel Controls (CW 801P).....	4-1

LIST OF TABLES

Table 3–1	Recommended Wire Gauge Selection Guide.....	2-2
Table 3–2	Recommended Cables	2-11
Table 6–1	Replacement Fuses.....	5-1

SECTION 0 INTRODUCTION

Elgar's ContinuousWave™ (CW) Series power sources deliver 800 VA or 1250 VA in a 2U high (3.5 inches), and 2500 VA in a 5.25-inch benchtop or rackmount chassis. Higher power and multiphase can be achieved by paralleling and multiphase interconnection. This requires optional slave cables. The switchmode Power Factor Corrected (PFC) input stage allows a wide range of input voltage and maximizes the power available from a wall outlet.

The CW series units are available in manual and programmable versions. This operation manual covers the programmable versions only.

Voltage, current, and frequency settings are quickly adjusted from the front panel encoders. In addition, the sources can be programmed remotely from the rear panel GPIB, RS-232, or analog port. The output is protected against overvoltage, overcurrent, and overtemperature conditions. A two-speed fan results in quieter operation at lower power levels.

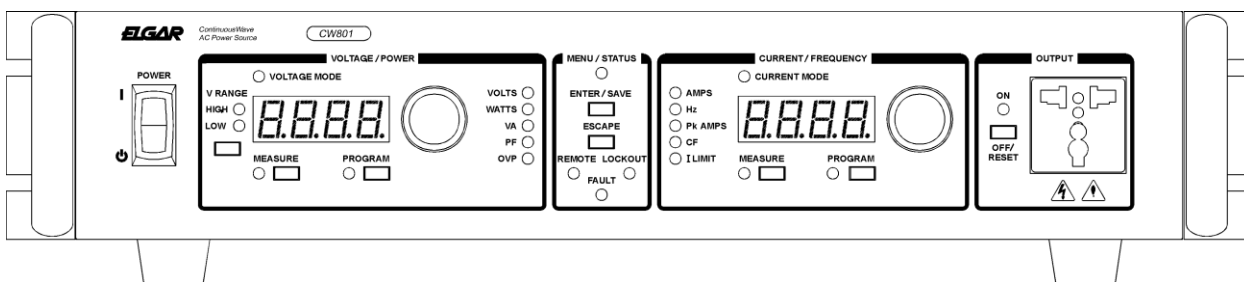

Figure 0–1 ContinuousWave Front Panel (Model CW 801P)

Key features of the CW Series AC power sources include:

- High performance/value design
- 800, 1250, and 2500 VA units available
- Low profile 3.5" rack height required for up to 1250 VA; 5.25" rack height required for 2500 VA
- Bench top or rack mount (optional slides available)

- 1 phase 45 to 500 Hz AC output; 45-1000 Hz with H-Option.
Units may be connected in multiphase configuration and/or paralleled for higher powers. (Consult factory for more than two units paralleled.) Multiphase/paralleling cables are optional.
- Transformer coupled output with disconnect relays
- 0 to 135V and 0 to 270V ranges; 0 to 155V and 0 to 310V ranges with V-Option
- CW 801P and CW 1251P versions have universal output socket on front panel.
All units have output power available at rear of unit.
- Remote sense leads for accurate output voltage
- Input PFC provides maximum utilization of available outlet current and wide range of input voltage and frequency
- CE mark
- UL/CUL (consult factory for availability)
- GPIB and RS-232 control
- Two large, 7-segment LED, 4-digit displays on front panel
- Set volts, overvoltage, frequency, current, and overcurrent by two front panel encoders
- Measure voltage, wattage, VA, power factor, current, peak current, and crest factor
- Display overvoltage, frequency, and overcurrent setting
- Over current shutdown or constant current mode menu-selectable
- Enable/disable output voltage rms loop menu-selectable
- Sync in, clock out, and analog programming of output voltage available through rear panel connector. These items are menu-selectable.
- Front panel lockout; measurement active
- Stored settings including: Power up to previous front panel setting or 0V
- 2-speed fan for low noise
- Side air intake, exhaust to rear
- All connectors on rear
(output power also available at front for CW 801P and CW 1251P)
- Chassis depth 20" (front panel and rear connectors add additional depth)
- Will fit in 24" RETMA rack system
- 1-year calibration interval, covers on soft calibration

SECTION 1 SPECIFICATIONS

1.1 Output

POWER

CW 801P	800 VA
CW 1251P	1250 VA
CW 2501P	2500 VA
Power Factor of Load	0 lag to 0 lead
Phase	All models single phase output

VOLTAGE

Ranges	0 to 135 VRMS or 0 to 270 VRMS, user selectable V–Option: 0 to 155 VRMS or 0 to 310 VRMS, user selectable
Accuracy	$\pm 0.1\%$ of full scale <100 Hz, $\pm 0.2\%$ of full scale ≥ 100 Hz at >5 VRMS output H–Option: $\pm 0.3\%$ of full scale >500 Hz
Resolution	0.1 VRMS
AC Noise Level	CW 801/1251P: <50 mVRMS typical in low-voltage range <85 mVRMS typical in high-voltage range CW 2501P: <100 mVRMS typical in low-voltage range <170 mVRMS typical in high-voltage range H–Option/V–Option: CW 801/1251P: <75 mVRMS typical in low-voltage range <125 mVRMS typical in high-voltage range CW 2501P: <125 mVRMS typical in low-voltage range <225 mVRMS typical in high-voltage range

Total Harmonic Distortion	0.25% typical ≤ 60 Hz; add 0.05%/10 Hz from >60 Hz to 100 Hz; add 0.5%/100 Hz at >100 Hz H-Option: 0.5% typical ≤ 60 Hz; add 0.05%/10 Hz from >60 Hz to 100 Hz; add 0.5%/100 Hz at >100 Hz up to 3.7%; increasing to 6% at 10% of full scale voltage, 100% full scale current, and full scale frequency
Amplitude Stability	$\pm 0.05\%$ of full scale over 8 hours at constant line, load and temperature after 15 minute warm-up typical
Load Regulation	$\pm 0.1\%$ full scale voltage for full resistive load to no load (<10 mVRMS typical, measured at point of sense)
Line Regulation	$\pm 0.1\%$ of full scale voltage for a $\pm 10\%$ line change from nominal line voltage (<5 mVRMS typical, measured at point of sense)
Remote Voltage Sense	5 VRMS total lead voltage drop

CURRENT

CW 801P(-H)	6.0 ARMS (135 VAC range), 3.0 ARMS (270 VAC range)
CW 1251P(-H)	9.4 ARMS (135 VAC range), 4.7 ARMS (270 VAC range)
CW 2501P(-H)	18.6 ARMS (135 VAC range), 9.3 ARMS (270 VAC range)
CW 801P-V	5.2 ARMS (155 VAC range), 2.6 ARMS (310 VAC range)
CW 1251P-V	8.2 ARMS (155 VAC range), 4.1 ARMS (310 VAC range)
CW 2501P-V	16.2 ARMS (155 VAC range), 8.1 ARMS (310 VAC range)
Accuracy	$\pm 0.5\%$ of full scale typical; for linear loads and >0.12 ARMS for CW 801P, >0.19 ARMS for CW 1251P, >0.37 ARMS for CW 2501P H-Option/V-Option: $\pm 0.75\%$ of full scale and ≤ 500 Hz; $\pm 1.0\%$ of full scale and >500 Hz
Resolution	0.01 ARMS

FREQUENCY

Range	45 to 500 Hz (45 to 1000 Hz for H-Option)
Accuracy	$\pm 0.02\%$ maximum
Resolution	0.1 Hz, 0.01 Hz for remote programming

PHASE

Range	-359 to +359 degrees Positive phase indicates time lag from reference
Accuracy	Within 100 microseconds of equivalent angle
Resolution	1 degree

1.2 Measurement**VOLTAGE**

Range	0 to 270 VRMS; V-Option: 0 to 310 VRMS
Accuracy	$\pm 0.1\%$ of range < 100 Hz; $\pm 0.2\%$ of range ≥ 100 Hz; at > 5 VRMS output; measured at point of remote sense H-Option: $\pm 0.3\%$ of range > 500 Hz
Resolution	0.1 VRMS

CURRENT*

Range	
CW 801P	0 to 6.0 ARMS
CW 1251P	0 to 9.4 ARMS
CW 2501P	0 to 18.6 ARMS
Accuracy	$\pm 0.5\%$ of range typical; for linear loads and > 0.12 ARMS for CW 801P, > 0.19 ARMS for CW 1251P, > 0.37 ARMS for CW 2501P H-Option/V-Option: $\pm 0.75\%$ of range and ≤ 500 Hz; $\pm 1.0\%$ of range and > 500 Hz
Resolution	0.01 ARMS

PEAK INSTANTANEOUS CURRENT*

Range	
CW 801P	0 to 25A
CW 1251P	0 to 35A
CW 2501P	0 to 70A
Accuracy	$\pm 2\%$ of range typical; at $> 2\%$ current range
Resolution	0.1A

PEAK INRUSH CURRENT* (Available in Remote Mode only)

Range

CW 801P	0 to 25A
CW 1251P	0 to 35A
CW 2501P	0 to 70A

Accuracy $\pm 2\%$ of range, typical; at $>2\%$ of RMS current range

Resolution 0.1A

FREQUENCY

Range 45 to 500 Hz
H-Option: 45 to 1000 Hz

Accuracy $\pm 0.02\%$ of value

Resolution of Display 0.1 Hz

POWER*

Range

CW 801P	0 to 800W
CW 1251P	0 to 1250W
CW 2501P	0 to 2500W

Accuracy $\pm 2\%$ of range for linear loads, typical

Resolution 1W

APPARENT POWER*

Range

CW 801P	0 to 800 VA
CW 1251P	0 to 1250 VA
CW 2501P	0 to 2500 VA

Accuracy $\pm 2\%$ of range for linear loads, typical

Resolution 1 VA

POWER FACTOR*

Range	0 to 1
Accuracy	±4% of range for linear loads, typical; at >10% of power range
Resolution	0.01

CREST FACTOR*

Range	0 to 3.5
Accuracy	±5% of range, typical; at 10% of RMS current range
Resolution	0.01

1.3 Input**VOLTAGE AND FREQUENCY**

CW 801P	90 to 264 VRMS, 47 to 63 Hz, single-phase
CW 1251P	103 to 264 VRMS, 47 to 63 Hz, single-phase
CW 2501P	180 to 264 VRMS, 47 to 63 Hz, single-phase

CURRENT

CW 801P(-H)(-V)	13.5 ARMS, maximum at 90 VRMS
CW 1251P(-H)(-V)	17.7 ARMS , maximum at 103 VRMS
CW 2501P(-H)(-V)	19.7 ARMS , maximum at 180 VRMS

POWER FACTOR >0.99 typical at full load nominal line

EFFICIENCY >73% typical at full load

H-Option/V-Option at 1,000 Hz: CW 801P, >68% typical;
CW 1251P, >70% typical; CW 2501P, >72% typical

***Note:** In a parallel system, the current/power displayed on the master unit is the sum of all units in the system.

1.4 Protection

Overcurrent: Shutdown mode
Accuracy: +/- 1% of full scale, for linear loads with current
>0.2 ARMS for CW 801P / CW 1251P, >0.4ARMS for CW 2501P

Over Voltage: Accuracy: +/-2% of full scale
Range: 35-300 VAC; V-Option: 35-344 VAC

Over Temperature: Internal monitor

Isolation Range: 500 VRMS between either output terminal and chassis.

1.5 Rear Panel Connections

GPIB

RS-232

M/S OUT

M/S IN

ANALOG SLAVE

Power In and Power Out Terminal Strips (see Sections 2.5 and 2.6)

1.6 General

DIMENSIONS

CW 801P: 3.5" (89 mm) H x 19" (483 mm) W x 20.6" (524 mm) D

CW 1251P: 3.5" (89 mm) H x 19" (483 mm) W x 20.6" (524 mm) D

CW 2501P: 5.25" (133 mm) H x 19" (483 mm) W x 20.6" (524 mm) D

WEIGHT

CW 801P: 48 lbs. (22 kg)

CW 1251P: 53 lbs. (24 kg)

CW 2501P: 86 lbs. (40 kg)

SHIPPING WEIGHT

CW 801P: 55.25 lbs. (25 kg)

CW 1251P: 60.25 lbs. (27 kg)

CW 2501P: 93.25 lbs. (43 kg)

REGULATORY COMPLIANCE

CE mark

UL and CUL (consult factory for availability)

ENVIRONMENTAL

Cooling: Dual fan speed with side air intake, exhaust to rear

Operating
Temperature: 0 to 40°C

Storage
Temperature: -40 to +70°C

Humidity: 0 to 85% at 25°C derate to 50% above 40°C (non-condensing)

Altitude: Operating full power available up to 6,000 feet, non-operating to 40,000 feet

Installation Category III, Pollution Degree 2

FOR INDOOR USE ONLY

1.7 Options and Accessories

Rack Slide Kit (Elgar part number K161570-01)

Multiphase/Parallel Cable (Elgar part number 890-499-00)

Master/Slave Cable (Elgar part number 890-497-40)

S: Sync In/Out (Clock/Lock)

H: Expanded Frequency Range 45 to 1000 Hz

V: Expanded Voltage Range 0-155/0-310 VRMS

Note: Product specifications are subject to change without notice.

This page intentionally left blank.

SECTION 2 INSTALLATION

The Elgar CW series power supply has been fully calibrated and tested prior to shipment. The instrument is ready for immediate use upon receipt.



CAUTION! *The CW unit weighs from 48 to 86 lbs. (22 to 40 kg), depending on the model. A two-person lift is recommended.*



WARNING! *Hazardous voltages are present when operating this equipment. Please read the Safety Notice at the beginning of this manual prior to installation, operation, or maintenance.*

2.1 Unpacking

Perform a visual inspection of the shipping container prior to accepting the package from the carrier. If extensive damage to the shipping container is evident, a description of the damage should be noted on the carrier's receipt and signed by the driver of the carrier agent.

Perform a visual inspection of the instrument when it is removed from the shipping container. Check for shipping damage such as dents, scratches, distortion, and damaged connectors.

If damage is not apparent until the instrument is unpacked, a claim for concealed damage should be placed with the carrier. In addition, the shipping container(s) and filler material should be saved for inspection. Forward a report of damage to the Elgar Service Department. Elgar will provide instructions for repair or replacement of the instrument.

If the instrument needs to be returned to Elgar, suitable shipping containers and packing materials must be used. If proper packing material is not available, contact Elgar to provide containers and shipping instructions.

Before shipping a product to Elgar, you must obtain a Return Material Authorization (RMA) number from Elgar's Repair Department. See the warranty page at the front of this manual for details.

2.2 Wire Gauge Selection

The following guidelines assist in determining the optimum cable specification for your power applications. These guidelines are equally applicable to both DC and low frequency AC (up to 450 Hz) power cabling. The same engineering rules apply whether going into or out of an electrical device. Thus, this guide applies equally to the input cable and output cable for this Elgar instrument and application loads.

Power cables must be able to safely carry maximum load current without overheating or causing insulation destruction. It is important to everyday performance to minimize IR (voltage drop) loss within the cable. These losses have a direct effect on the quality of power delivered to and from instruments and corresponding loads.

When specifying wire gauge, the operating temperature needs to be considered. Wire gauge current capability and insulation performance drops with the increased temperature developed within a cable bundle and with increased environmental temperature. Thus, short cables with generously derated gauge and insulation properties are recommended for power source applications.

Avoid using published commercial utility wiring codes, which are designed for the internal wiring of homes and buildings. Although these codes accommodate the safety factors of wiring loss, heat, breakdown insulation, aging, etc., they consider that up to 5% voltage drop is acceptable. Such a loss directly detracts from the quality performance specifications of this Elgar instrument. Frequently, these codes do not consider bundles of wire within a cable arrangement.

In high performance applications, as in motor start-up and associated inrush/ transient currents, additional consideration is required. The cable wire gauge must consider peak voltages and currents that may be up to ten times the average values. An underrated wire gauge adds losses that alter the inrush characteristics of the application and thus the expected performance.

Table 2–1 identifies popular ratings for DC and AC power source cable wire gauges.

Column 1 Size (AWG)	Column 2 Amperes (Max)	Column 3 Ohms/100 ft (1 way)	Column 4 IR Drop/100 ft (Col 2 x Col 3)
14	15	0.257	3.85
12	20	0.162	3.24
10	30	0.102	3.06
8	40	0.064	2.56
6	55	0.043	2.36
4	70	0.025	1.75
2	95	0.015	1.42
1/0	125	0.010	1.25
3/0	165	0.006	1.04

Table 2–1 Recommended Wire Gauge Selection Guide

The following notes apply to Table 2–1 and to the power cable definition:

1. The above figures are based upon insulated copper conductors at 25 °C (77 °F), two current carrying conductors in the cable plus a safety (chassis) ground.

Columns 3 and 4 refer to “one way” ohms and IR drop of current carrying conductors (e.g., a 50-foot cable contains 100 feet of current carrying conductor).

2. Determine which wire gauge for the application by knowing the expected peak load current (I_{peak}), the maximum tolerated voltage loss (V_{loss}) within the cable, and the one way cable length.

The formula below determines which ohms/100 feet entry is required from Column 3. Read the corresponding wire gauge from Column 1.

(Column 3 value) =

$$V_{\text{loss}}/[I_{\text{peak}} \times 0.02 \times (\text{cable length})]$$

Where:

Column 3 value =

Entry of the table above.

Cable length =

One way cable length in feet.

V_{loss} =

Maximum loss, in volts, permitted within cable.

Special case: Should the V_{loss} requirement be very loose, I_{peak} may exceed the maximum amperes (Column 2). In this case, the correct wire gauge is selected directly from the first two columns of the table.

Example: A 20 ampere (I_{peak}) circuit which may have a maximum 0.5 volt drop (V_{loss}) along its 15-foot cable (one way cable length) requires (by formula) a Column 3 resistance value of 0.083. This corresponds to wire gauge size 8 AWG.

If the cable length was 10 feet, the Column 3 value would be 0.125 and the corresponding wire gauge would be 10 AWG.

3. Aluminum wire is not recommended due to soft metal migration at the terminals which may cause long term (on the order of years) poor connections and oxidation. If used, increase the wire gauge by two sizes (e.g., specify 10 gauge aluminum instead of 14 gauge aluminum).

4. Derate the above wire gauge (use a heavier gauge) for higher environmental temperatures since conductor resistance increases with temperature.

<u>Temperature</u>	<u>Current Capability</u>
40°C 104°F	80%

5. Derate the above wire gauge (use a heavier gauge) for an increased number of current carrying conductors. This offsets the thermal rise of bundled conductors.

<u>No. of Conductors</u>	<u>Current Capability</u>
3 to 6	80%
Above 6	70%

6. The preferred insulation material is application dependent. Elgar's recommendation is any flame retardant, heat resistant, moisture resistant thermoplastic insulation rated to a nominal 75°C (167°F). Voltage breakdown must exceed the combined effects of:

- The rated output voltage;
- Transient voltages induced onto the conductors from any source;
- The differential voltage to other nearby conductors; and,
- Safety margins to accommodate degradations due to age, mechanical abrasion and insulation migration caused by bending and temperature.

7. As frequency increases, the magnetic field of the current carrying conductors becomes more significant in terms of adverse coupling to adjacent electrical circuits. Use twisted pairs to help cancel these effects. Shielded twisted pairs are even better. Avoid close coupling with nearby cables by using separate cable runs for high power and low power cables.

8. The above general values and recommendations should be reviewed, modified, and amended as necessary for each application. Cables should be marked with appropriate safety WARNING decals as hazardous voltages may be present.

2.3 Mounting Instructions

Refer to Figure 2–1 through Figure 2–4 for mounting dimensions and other installation information for the CW Series power supplies.

The units are equipped with mounting feet for bench top use. They are mounted to the chassis with pem-nuts and may be removed easily for rack mount application.

The units are 3.5" and 5.25" (89 mm and 133 mm) high, and are designed to be installed in a standard 19" (483 mm) RETMA rack. Pem-nuts have been built into the chassis for mounting optional slides. The CW mounting kit, Elgar part number K161570-01, contains the appropriate slides and mounting brackets.

If you elect not to use slides, mount the unit with standard support angles to sustain the weight of the unit in the rack. Note that the front panel mounting ears are not intended to support its weight in rack mounting.

For installations that include slides, use a #10 lock washer, as supplied in the CW-P mounting kit, with each of the two mounting screws indicated in Figure 2–1.

These washers are required on the right side only to limit the depth of screw penetration into the chassis, which must be less than 0.25".

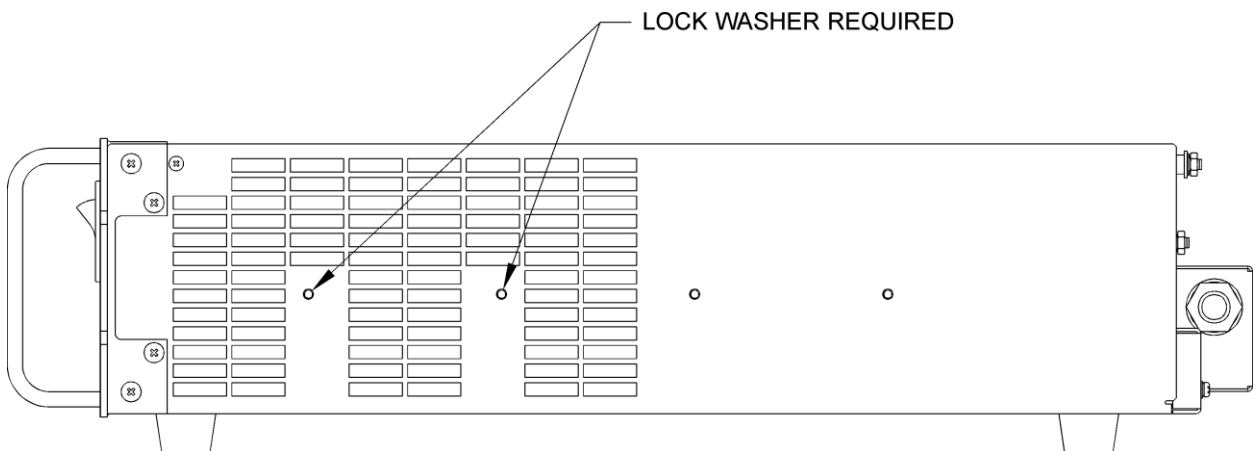

Figure 2–1 Slide Mounting

2.4 Cooling

The CW unit employs internal fans to circulate cooling air. The air is drawn into the chassis along its sides, and is exhausted through the rear panel. For maximum product life and reliability, do not allow the airflow to be impeded.



CAUTION!

Avoid blocking the instrument air intakes or exhaust.

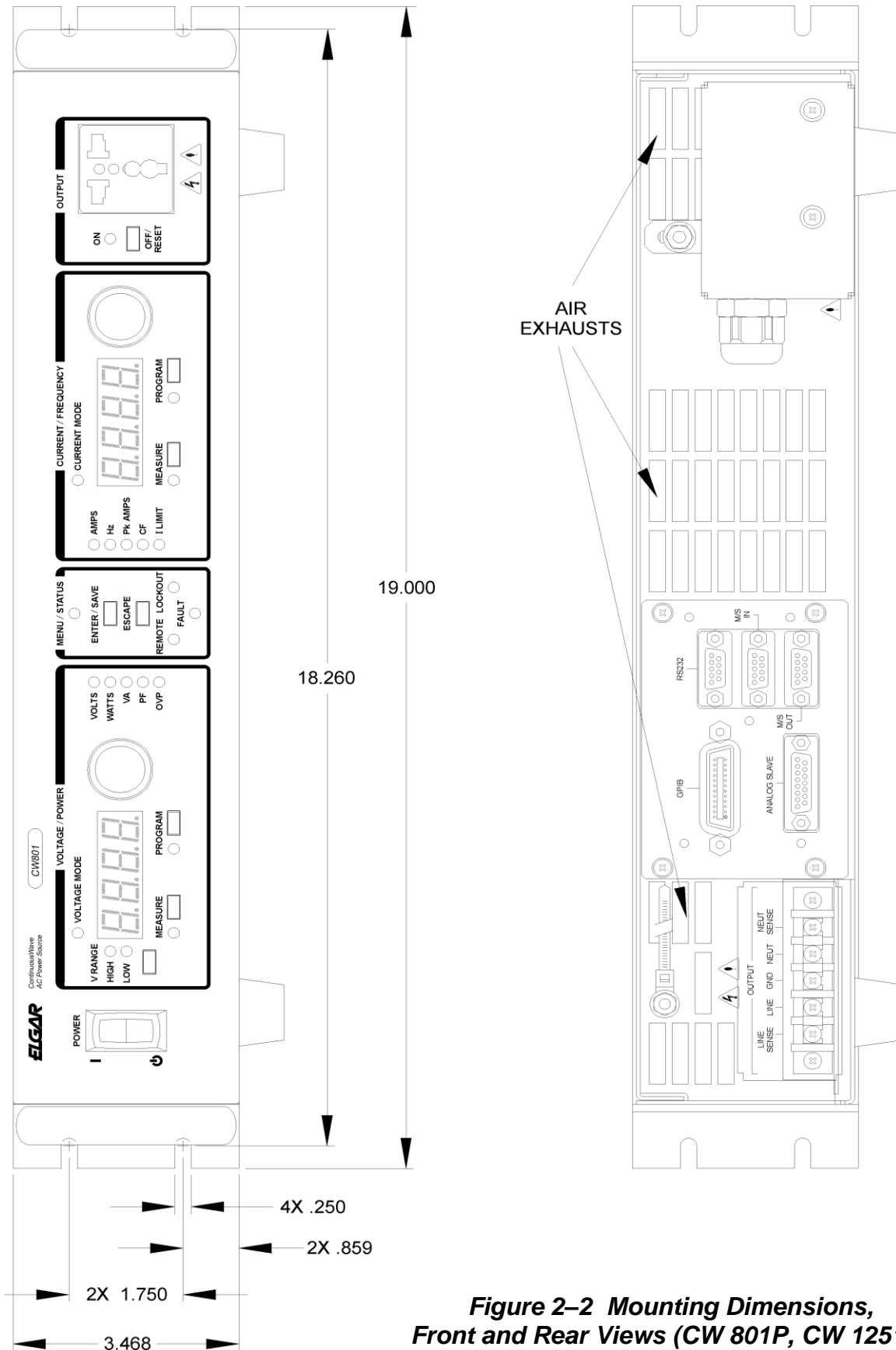

Figure 2–2 Mounting Dimensions, Front and Rear Views (CW 801P, CW 1251P)

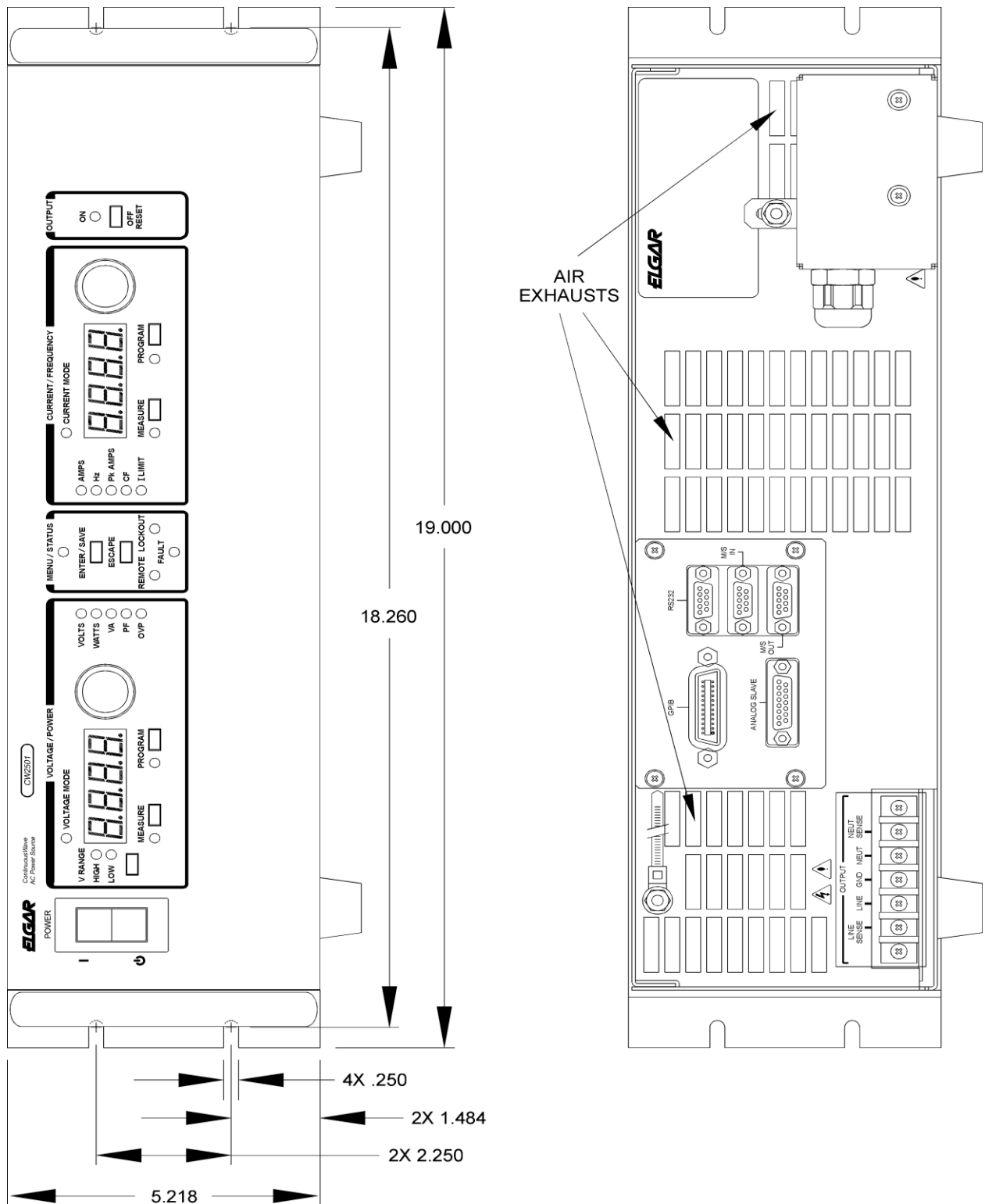
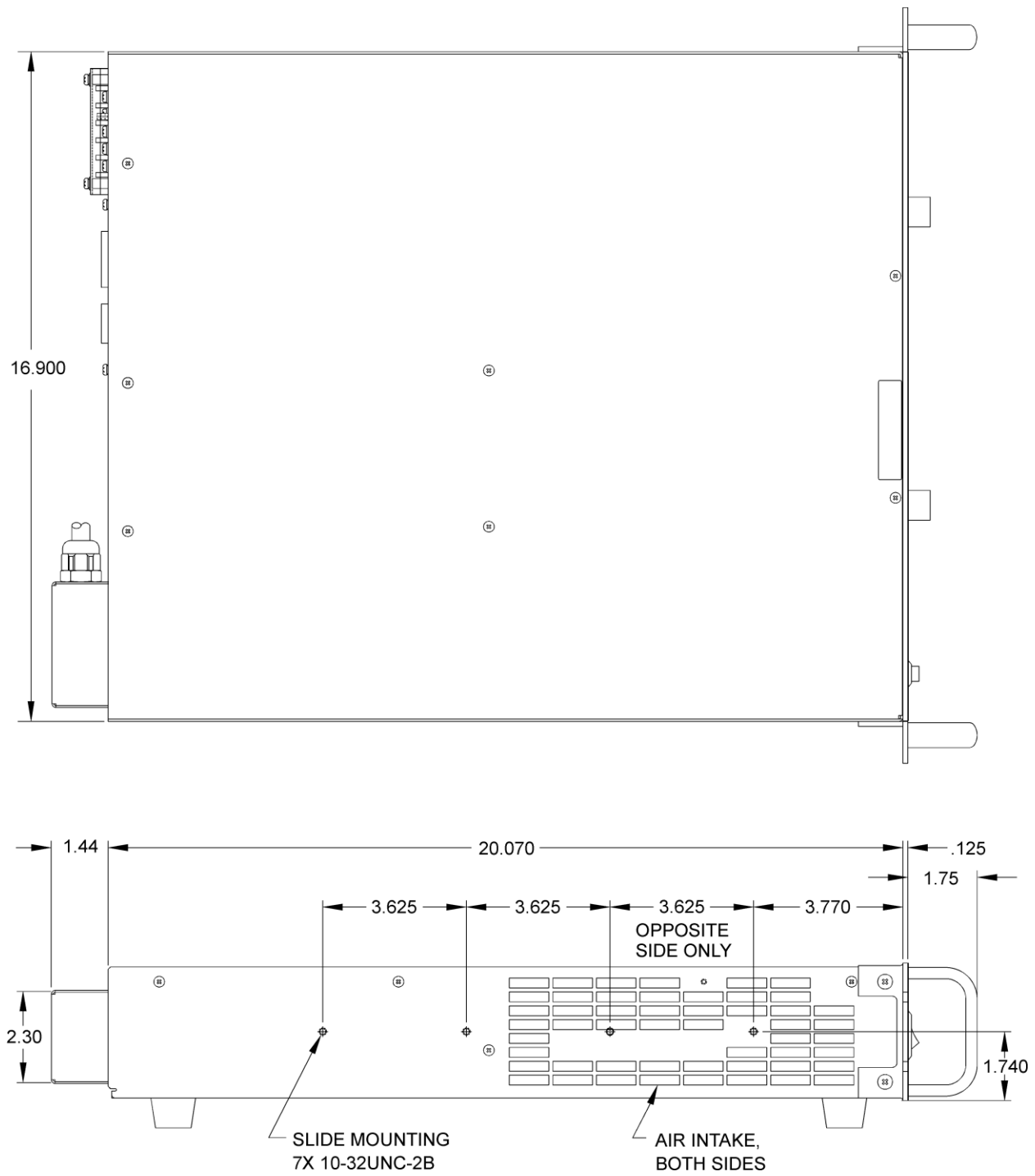
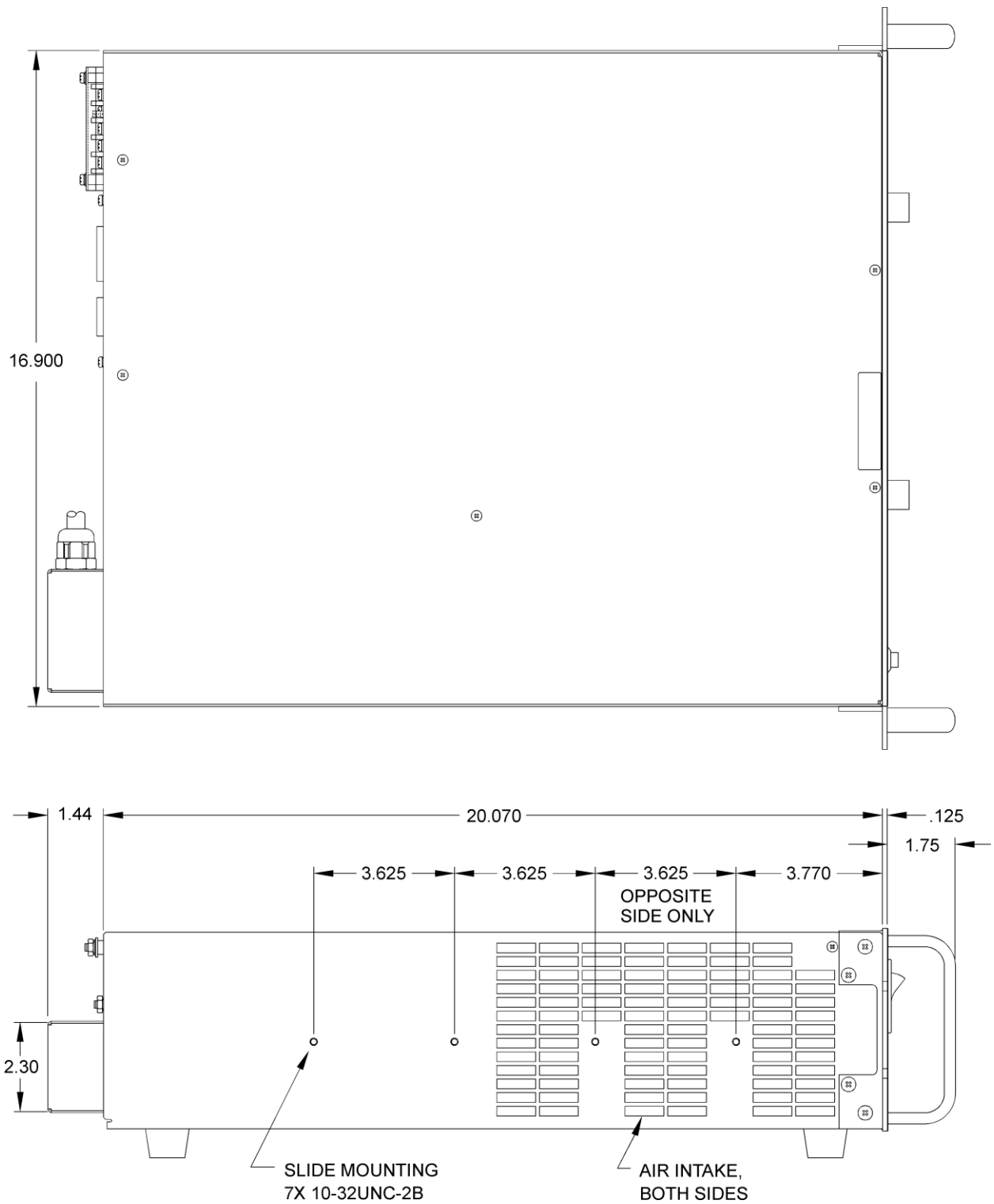

Figure 2-3 Mounting Dimensions, Front and Rear Views (CW 2501P)



**Figure 2-4 Mounting Dimensions,
Top and Side Views (CW 801P and CW 1251P)**



**Figure 2-5 Mounting Dimensions,
Top and Side Views (CW 2501P)**

2.5 Power In Connections

Connect input power to the INPUT terminal block on the rear panel as specified below. Refer to Figure 2–6.

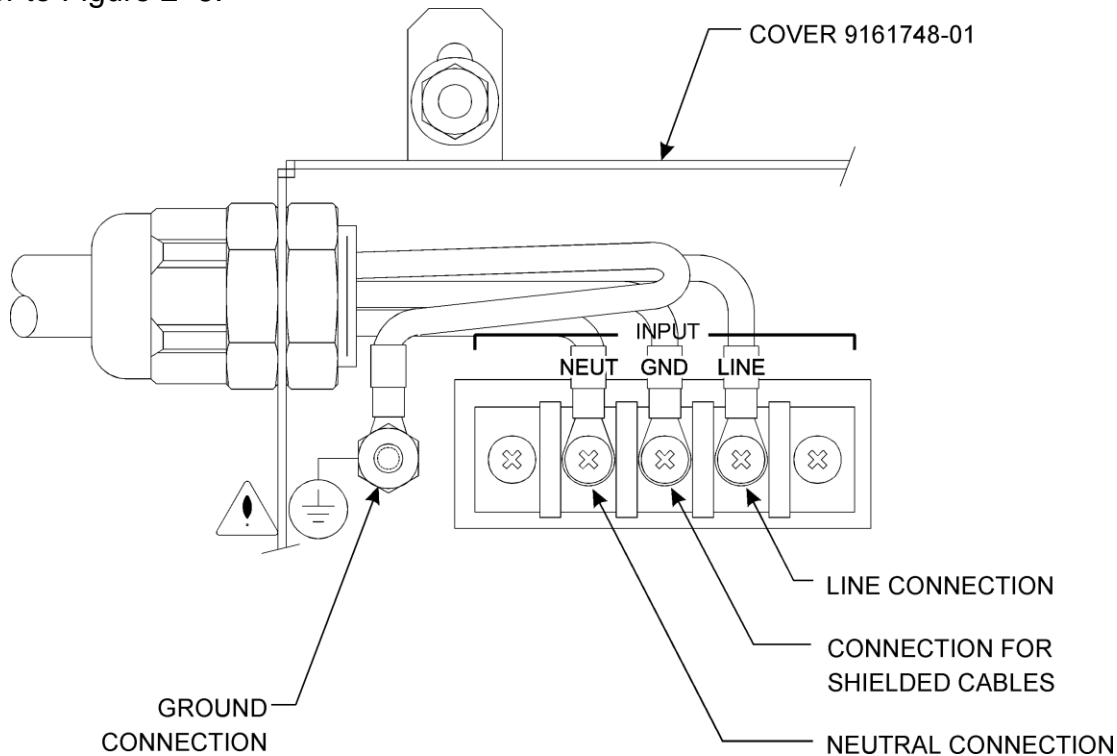

Figure 2–6 Input Power Connections



WARNING! For input voltages >120V, do not reverse *LINE* and *NEUT*. Reversed connections will result in pulsing noises from the supply.

2.5.1 Single-Phase Supply Connections

1. Remove the protective cover from the terminal block.
2. Route the cables through the strain relief device. Refer to Table 2–2 for cable recommendations.
3. Connect SAFETY GROUND to the GROUND stud located next to the INPUT terminal block. For additional safety, include a loop between the GROUND stud and the strain relief device, as shown in Figure 2–6.
4. Connect shields, if any, to the GND connector of the INPUT terminal block.
5. Connect NEUTRAL, if available, to the NEUT connector.
6. Connect LINE to the LINE connector.
7. Reinstall the protective cover on the terminal block. Tighten the strain relief device.

2.5.2 Split-Phase Supply Connections 120–0–120V

1. Remove the protective cover from the terminal block.
2. Route the cables through the strain relief device. Refer to Table 2–2 for cable recommendations.
3. Connect NEUT to 120V.
4. Connect LINE to the other 120V.

Wiring across the full voltage will allow lower line currents to be used.

5. Reinstall the protective cover on the terminal block. Tighten the strain relief device.

2.5.3 Three-Phase Supply Connections

1. Remove the protective cover from the terminal block.
2. Route the cables through the strain relief device. Refer to Table 2–2 for cable recommendations.
3. Connect one phase to LINE and Neutral to NEUT. If Neutral is not available, connect LINE and NEUT across any of the phases.
4. Reinstall the protective cover on the terminal block. Tighten the strain relief device.

CW Model	North American	International
CW 801P	18A/300V, 3x14 AWG O.D.=9.6 mm	16A/300V, 3x1.5 mm ² O.D.=8.0–9.8 mm
CW 1251P and CW 2501P	25A/300V, 3x12 AWG O.D.=11.3 mm	25A/300V, 3x2.5 mm ² O.D.=9.6–12.0 mm VDE approved

Table 2–2 Recommended Cables



WARNING! To protect the operator, the wire connected to the GND terminal must be connected to earth ground. This unit should not be operated without an adequate ground connection.



CAUTION! A device to disconnect the CW system from the energy supply source is required. This switch or circuit breaker must be close to the CW system, within easy reach of the operator, and clearly labeled as the disconnection device for the CW system.



CAUTION! Use wire rated for currents drawn as specified on equipment label.

2.6 Power Out Connections

1. Remove the protective cover from the terminal block.
2. A factory jumper has been added to connect NEUTRAL to GROUND. If the front connector requires LINE and NEUTRAL to be reversed, move this jumper to connect LINE to GROUND. See Figure 2–7 below. Most loads require NEUTRAL to be grounded.

The factory jumper may be removed if the load has a GROUND or if LINE or NEUTRAL voltages are held to less than 500 VRMS with respect to chassis.

3. Reinstall the protective cover on the terminal block.



WARNING! Verify that the load is set up to be *LINE GROUNDED* or *NEUTRAL GROUNDED*. (Equipment with polarized plugs requires *NEUTRAL* to be grounded.)

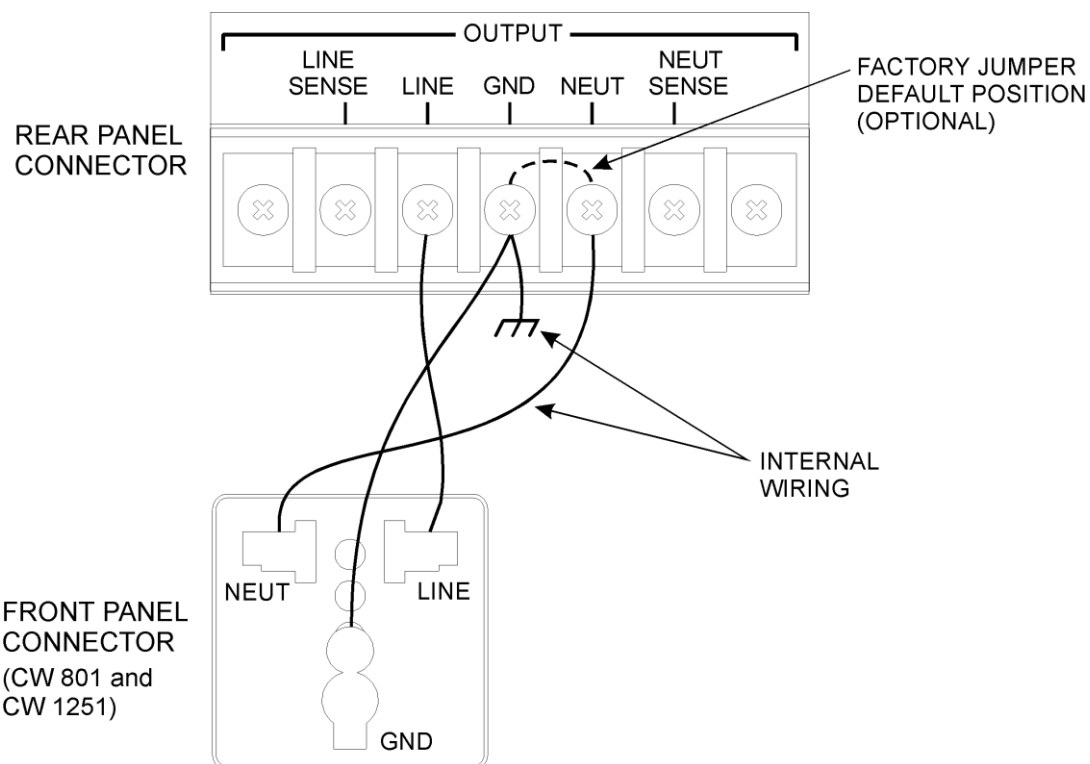

Figure 2–7 Output Power Connections

2.7 Sense Connections

The CW Series unit can be used with or without remote sense leads connected to the load. Where the sense leads (line and neutral sense) are connected determines the point at which the CW output voltage will be precisely regulated.

As shipped, the units are configured for local sense operation. This is achieved by connecting shorting jumpers between the sense and AC output terminals of the rear panel output terminal block, as shown in Figure 2–8.

When using remote sensing, the shorting jumpers must be removed, and the remote sense leads connected from the CW sense terminals to the load. The point of voltage regulation will now be at the load, and any voltage drop across the interconnecting output cable will be compensated.

In the event that the external remote sense circuit opens, the CW maintains control of the output voltage by utilizing a redundant sense circuit. This redundant circuit is comprised of 10k Ω resistors internally connected from the AC output terminals to the voltage control circuitry. However, since the unit is calibrated with the sense leads connected, this mode of operation will incur reduced accuracy in the AC output voltage because of the presence of the 10k Ω resistors.

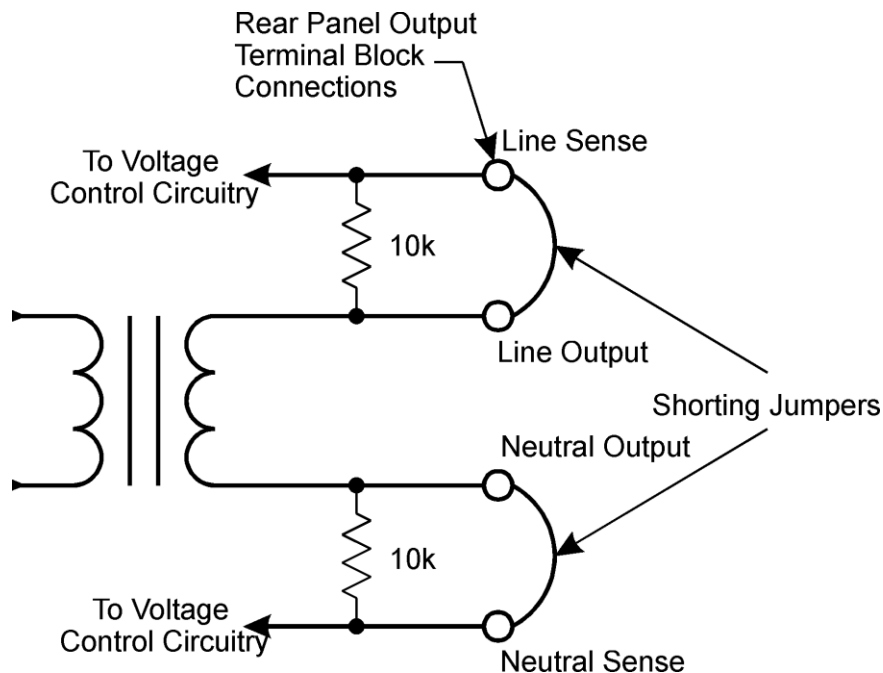

Figure 2–8 Output Voltage Sensing Configuration

To utilize remote sensing at the user's load, follow these steps:

1. Remove the protective cover from the terminal block.
2. Route the cables through the strain relief device located above the terminal block. Twisted shielded leads for power and sense leads are recommended for the lowest noise operation. If used, shields should be connected to a CW output terminal block GND ground connector, as shown in Figure 2–9.
3. Disconnect local–sense shorting jumpers. See Figure 2–9
4. Connect the sense leads as shown in Figure 2–9.
5. Reinstall the protective cover on the terminal block.

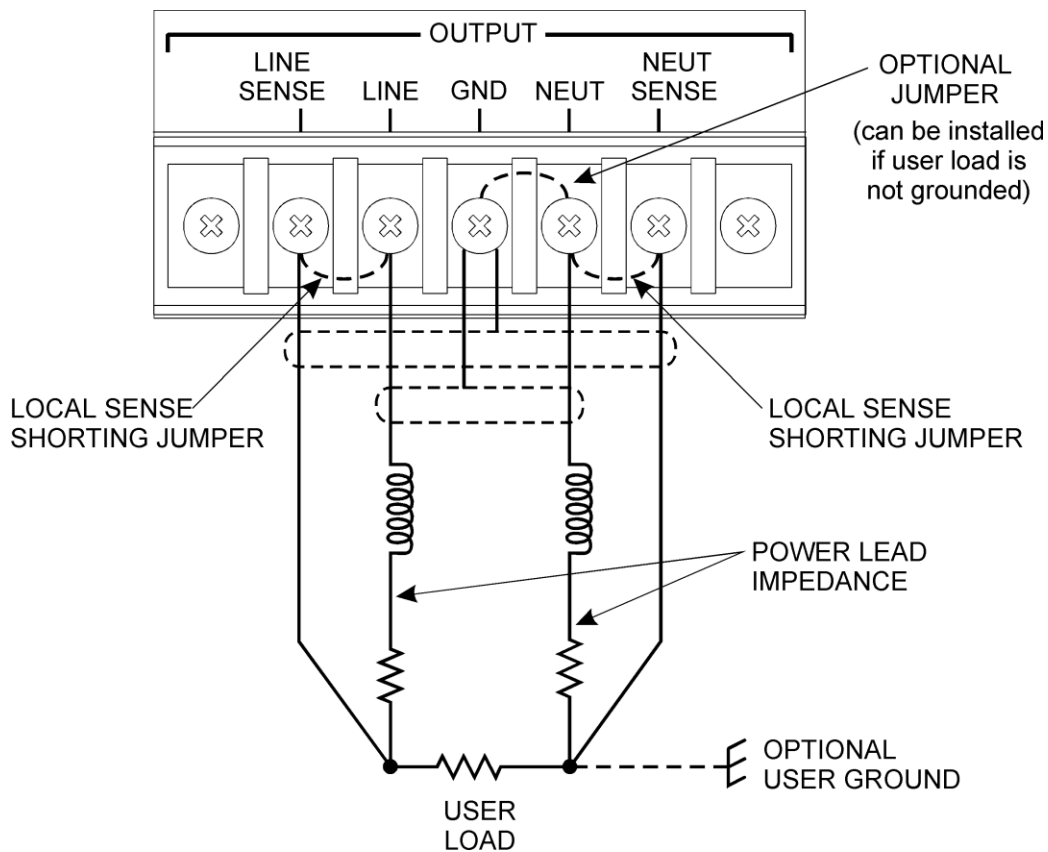

Figure 2–9 Sense Connections

2.8 Remote Control Signal

Remote control allows you to set output voltage, lock to an external frequency source, or send out a TTL compatible sync signal.

The 9-pin Subminiature-D master/slave connector labeled M/S IN on the rear panel allows you to make the necessary connections for remote control. See Figure 2–10.

Pins 1, 2, 3, 6, 7, and 8 of the M/S IN connector provide control signals for multiphase/paralleled systems; do not make any user connections to these pins. In a multiphase/paralleled system, the master unit uses the M/S IN connector for analog amplitude control or synchronizing to external frequency sources.

	Pin Number	Function
	4	User Ground (at GPIB Ground potential)
	5	Analog Amplitude Control (0 to 5 VDC for zero to set maximum voltage)
	9	Clock Lock Input/Output
	1, 2, 3, 6, 7, 8	Do not make connection

Figure 2–10 M/S IN Connector

2.8.1 Analog Amplitude Control

- Set unit to Analog In (analog input state = ON. See Section 4.3.10).
- Set HIGH or LOW range, and maximum output voltage (corresponding to 5 VDC analog amplitude control) by front panel, GPIB, or RS232 command.
- 0 to 5 VDC will set the output from 0 to the maximum voltage programmed (on the range selected), as set by front panel controls, GPIB, or RS232 command.
- If needed, set 'Program keys locked mode.' See section 4.3.5.

2.8.2 Lock to External Frequency Source

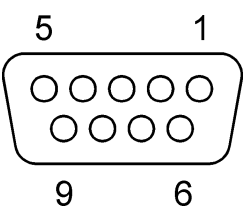
- Set direction of Clock to 'IN' (see Section 4.3.9).
- Signal can be 2 to 12V amplitude, and at least 10 microseconds wide. Triggering shall occur on the leading edge of the pulse. For zero programmed phase delay the output sinewave shall go from zero to positive.
- Delay angle can be programmed 0 to 359 degrees with a resolution of 1 degree.
- Input impedance is typically 10k ohm.

2.8.3 Sync Output Pulse

- Set direction of Clock to 'OUT' (see Section 4.3.9).
- Sync can be programmed relative to zero to positive crossing of output sinewave. Waveform amplitude typically 5V. Pulse width typically 10 microseconds. Signal shall start with a zero volt to positive voltage edge, $\pm 100 \mu\text{S}$.
- Programming range is 0 to 359 degrees of lag. Resolution 1 degree.
- Output impedance is typically less than 1k ohm.

2.9 Master/Slave Configurations

The CW-P series programmable power supply can be paralleled to achieve higher power. One, two, or three phase(s) can be paralleled to a depth of two units per phase. A given phase will have one "Master" and one or more "Slaves." The master and slave require special cables (two) between them. The outputs must be connected together with equal gauge and length power leads, the sense leads must be connected on the master, and each unit requires special programming. Programming of the units is performed from the front panel through the menu systems, or through the GPIB/RS-232 command interface. Once a unit is configured to be a slave, its command interface is not to be used when load wiring is connected.

When a multi-phase master/slave configuration is configured, the only GPIB/RS-232 connected unit is to be the A phase master. Attempting to control any other units in the array is specified as an illegal operation, and the results are undefined and potentially destructive. The command interfaces of a slave are allowed to remain operational for the purpose of returning the unit to a standalone or different slave configuration.

Note: Remove load wiring before reconfiguring a slave unit via the menu or command interfaces.

The CW-P series power supplies are configured for master/slave operations in the following order:

1. Disconnect load wiring to the individual CW power supply.
2. Disconnect any master/slave wiring (M/S IN, M/S OUT, and Analog Slave cables).
3. Ensure that source mains are connected and power up the CW.
4. Through the front panel menu system or through the command interface, specify the location of the CW in the master/slave matrix. See Sections 2.9.1 and 2.9.2 for examples.
5. Perform steps 1-3 for all CW units in the matrix.

6. Power up all CW units simultaneously, and ensure that each unit is reporting its address properly on the front panel.
7. Power down all CW units.
8. Connect load wiring as documented below.
9. Connect M/S OUT and M/S IN cables (Elgar PN 890-499-00) between each CW in a daisy chain pattern.
10. Connect master/slave, analog slave cables (Elgar PN 890-497-40) from master to slave, one on each master/slave pair.
11. Power up all CW units simultaneously, or the master unit last.
12. Perform all control operations on the A phase CW master unit.

This manual provides methods used to parallel a configuration of two units per phase.

2.9.1 Setup for Single-Phase, Two Units

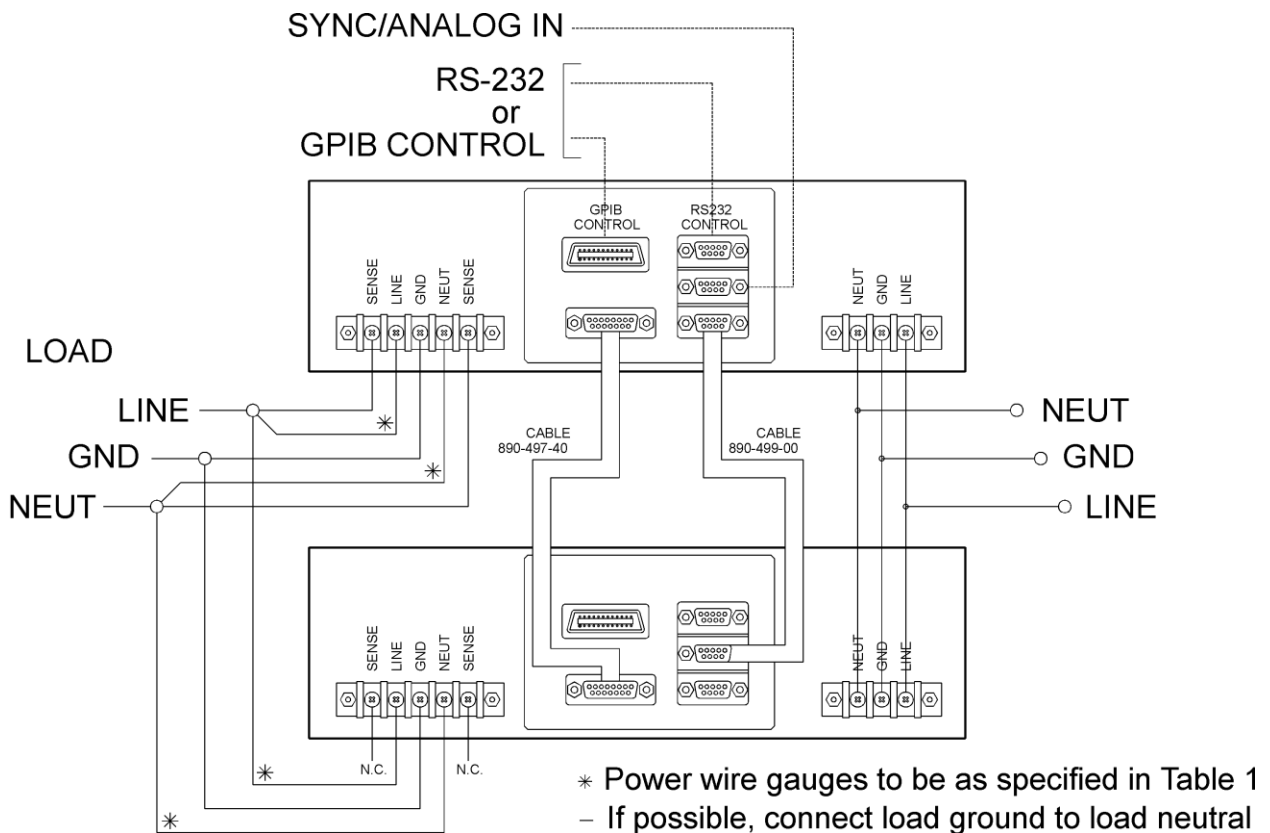

Figure 2–11 Wiring Diagram for One Phase, Master/Slave Configuration

Setup 1–Phase Master/Slave Pair Using Menu System

1. Ensure load wiring is removed from the two CW units.
2. Ensure no master/slave cables are attached to “Analog Slave” connectors on CW units.
3. Ensure no master/slave cables are connected to the “M/S IN “ and “M/S OUT” connectors.
4. Connect the mains wiring to the line terminals.
5. Power up both CW units.
6. On the master CW press the “ENTER/SAVE” button.
7. Rotate the left knob CW until the left display reads “Conf”.
8. Rotate the right knob until the right display reads A0A1.
9. Press the ENTER/SAVE button.
10. Press the ENTER/SAVE button.
11. Rotate the left knob CW until the left display reads “Addr”.
12. Rotate the right knob until the right display reads 0.
13. Press the ENTER/SAVE button.
14. Press the ENTER/SAVE button.
15. Rotate the left knob CW until the left display reads “ChAn”.
16. Rotate the right knob until the right display reads A.
17. Press the ENTER/SAVE button.
18. On the slave CW press the ENTER/SAVE button.
19. Rotate the left knob until the left display reads “Addr”.
20. Rotate the right knob until the right display reads “1”.
21. Press the ENTER/SAVE button.
22. Power down both CW power supplies.
23. Connect Elgar cable 890-497-40 between the master “Analog Slave” and the slave “Analog Slave” connectors.

24. Connect the Elgar cable 890-499-00 between the master “M/S OUT” and the slave “M/S IN” connectors.
25. Connect the load wiring as shown in Figure 2–11 above.
26. Power up both CW units simultaneously.
27. Control the master/slave pair by controlling the CW master via the front panel or its command interface.

Setup 1-Phase Master/Slave Pair Using Remote Command Interface

The CW master/slave attributes can be controlled using the GPIB/RS-232 command interface instead of using the front panel menu system. When adjusting the parameters in this manner, the CW voltage sourcing commands must not be controlled through the command interface of a slaved unit.

1. Setting the A Phase Master configuration parameter via the command interface:
 - SYST:SLAVECONFIG A0A1 Specifies that this A phase master has only one slave
 - SYST:SLAVECONFIG A0B1 Specifies that this A phase master has a B phase slave and each unit has a slave for a total of 4 CW units.
 - SYST:SLAVECONFIG A0C1 Specifies that this A phase master has a B phase slave and a C phase slave and each unit has a slave for a total of 6 CW units.
 - SYST:SLAVECONFIG? Returns the present parameter setting

Note: The SLAVECONFIG parameter only applies if the SLAVEADDR is set to 0 and the SLAVECHAN is set to A on the A master unit. Only the A phase master uses this parameter.

2. Setting the Slave address parameter via the command interface:
 - SYST:SLAVEADDR 0 Specifies that this CW is the top unit for A,B or C phases
 - SYST:SLAVEADDR? Returns the present address parameter
3. Setting the Slave phase parameter via the command interface:
 - SYST:SLAVECHAN A Specifies that this CW is in the A channel, either the master or a slave.
 - SYST:SLAVECHAN B Specifies that this CW is in the B channel and, by definition, a slave.
 - SYST:SLAVECHAN C Specifies that this CW is in the C channel and, by definition, a slave.
 - SYST:SLAVECHAN? Returns the present phase assignment set

2.9.2 Setup for Three-Phase, Two Units per Phase

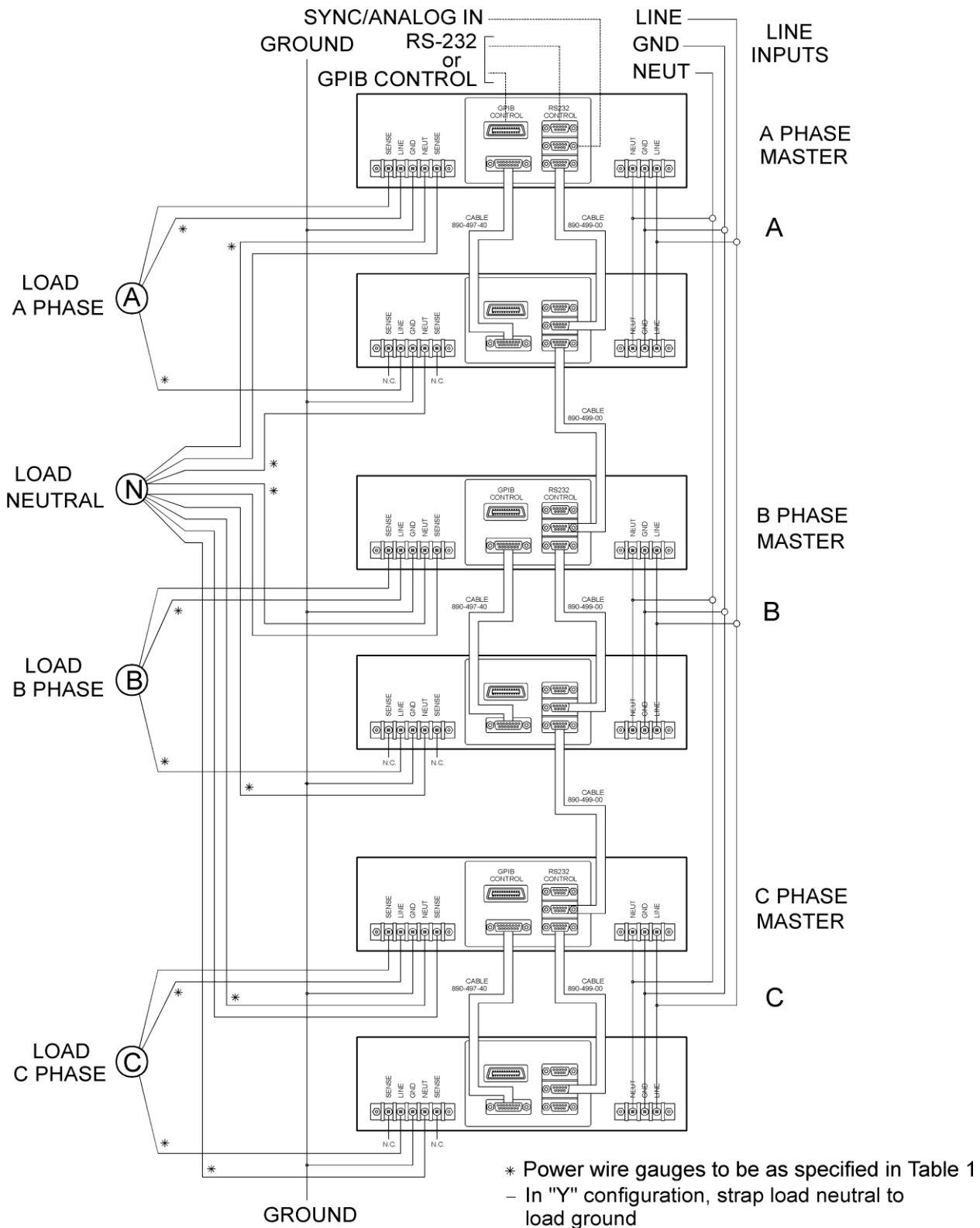

Figure 2-12 Wiring Diagram for Three Phase, Master/Slave Configuration

Setup Six CW Units as 3-Phase Master/Slave Set using Menu System

1. Ensure load wiring is removed from the six CW units.
2. Ensure no master/slave cables are attached to “Analog Slave” connectors on CW’s.
3. Ensure no master/slave cables are connected to the “M/S IN “ and “M/S OUT” connectors.
4. Connect the mains wiring to the line terminals.
5. Assign labels to the six CW units “A master”, “B master”, “C master”, “A slave”, “B slave”, “C slave”.
6. Power up six CW units.
7. Set up the A phase.
8. On the A master CW press the “ENTER/SAVE” button.
9. Rotate the left knob CW until the left display reads “Conf”.
10. Rotate the right knob until the right display reads A0C1.
11. Press the ENTER/SAVE button.
12. Press the ENTER/SAVE button.
13. Rotate the left knob until the left display reads “ChAn”.
14. Rotate the right knob until the right display reads “A”.
15. Press the ENTER/SAVE button.
16. Press the ENTER/SAVE button.
17. Rotate the left knob until the left display reads “Addr”.
18. Rotate the right knob until the right display reads “0”.
19. Press the ENTER/SAVE button.
20. On the A slave CW press the ENTER/SAVE button.
21. Rotate the left knob until the left display reads “Addr”.
22. Rotate the right knob until the right display reads “1”.
23. Press the ENTER/SAVE button.
24. Press the ENTER/SAVE button.
25. Rotate the left knob until the left display reads “ChAn”.

26. Rotate the right knob until the right display reads "A".
27. Press the ENTER/SAVE button.
28. Set up the B phase.
29. On the B master CW press the "ENTER/SAVE" button.
30. Rotate the left knob until the left display reads "Addr".
31. Rotate the right knob until the right display reads "0".
32. Press the ENTER/SAVE button.
33. Press the ENTER/SAVE button.
34. Rotate the left knob until the left display reads "ChAn".
35. Rotate the right knob until the right display reads "B".
36. Press the ENTER/SAVE button.
37. On the B slave CW press the ENTER/SAVE button.
38. Rotate the left knob until the left display reads "Addr".
39. Rotate the right knob until the right display reads "1".
40. Press the ENTER/SAVE button.
41. Press the ENTER/SAVE button.
42. Rotate the left knob until the left display reads "ChAn".
43. Rotate the right knob until the right display reads "B".
44. Press the ENTER/SAVE button.
45. Set up the C phase.
46. On the C master CW press the "ENTER/SAVE" button.
47. Rotate the left knob until the left display reads "Addr".
48. Rotate the right knob until the right display reads "0".
49. Press the ENTER/SAVE button.
50. Press the ENTER/SAVE button.
51. Rotate the left knob until the left display reads "ChAn".
52. Rotate the right knob until the right display reads "C".
53. Press the ENTER/SAVE button.

54. On the C slave CW press the ENTER/SAVE button.
55. Rotate the left knob until the left display reads "Addr".
56. Rotate the right knob until the right display reads "1".
57. Press the ENTER/SAVE button.
58. Press the ENTER/SAVE button.
59. Rotate the left knob until the left display reads "ChAn".
60. Rotate the right knob until the right display reads "C".
61. Press the ENTER/SAVE button.
62. Power down six CW power supplies.
63. Connect Elgar cable 890-497-40 between the A master "Analog Slave" and the A slave "Analog Slave" connectors.
64. Connect Elgar cable 890-497-40 between the B master "Analog Slave" and the B slave "Analog Slave" connectors.
65. Connect Elgar cable 890-497-40 between the C master "Analog Slave" and the C slave "Analog Slave" connectors.
66. Connect up all of the daisy chained cables. The unit order is suggested below in steps 67 through 71. As long as A master is the origin, all other daisy chained units can be in any order.
67. Connect the Elgar cable 890-499-00 between the A master "M/S OUT" and the A slave "M/S IN".
68. Connect the Elgar cable 890-499-00 between the A slave "M/S OUT" and the B master "M/S IN".
69. Connect the Elgar cable 890-499-00 between the B master "M/S OUT" and the B slave "M/S IN".
70. Connect the Elgar cable 890-499-00 between the B slave "M/S OUT" and the C master "M/S IN".
71. Connect the Elgar cable 890-499-00 between the C master "M/S OUT" and the C slave "M/S IN".
72. Connect the load wiring as shown in Figure 2-12 above.
73. Power up six CW units simultaneously.
74. Control the master/slave array by controlling the CW A master via the front panel or its command interface.

This page intentionally left blank.

SECTION 3 OPERATION

This section details the front panel operations of the CW series power source, including the initialization process and some system operations.

3.1 CW Front Panel Controls and Indicators

The controls and indicators on the front panel of the CW are detailed below. Refer to Figure 3–1.

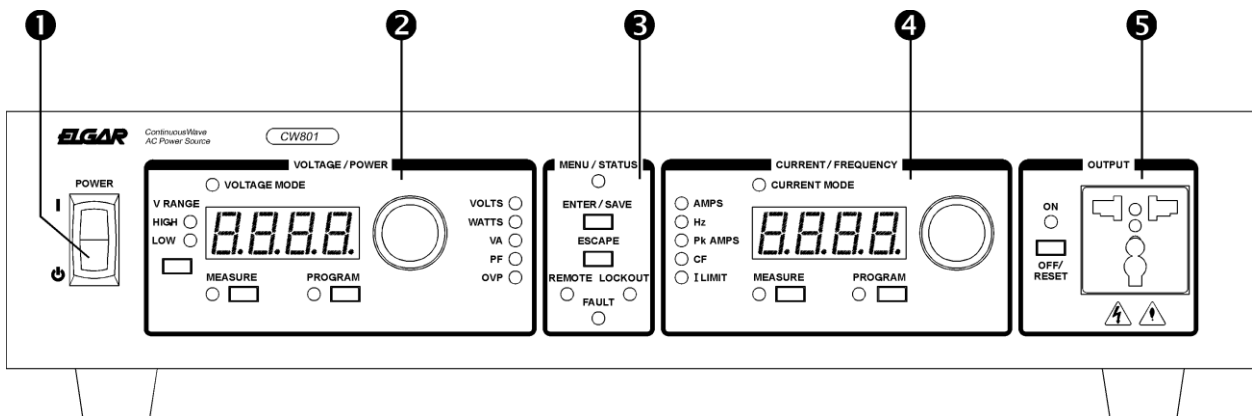

Figure 3–1 Front Panel Controls (CW 801P)

❶ Power Switch

Press the top portion of the switch to turn power on, press the bottom portion of the switch to turn the power supply off. When power is turned on, the unit goes through a power up cycle that may take several seconds before it is ready for operation.

❷ VOLTAGE/POWER Section

These controls and indicators, located on the left side of the front panel, are used to measure and program the voltage/power parameters.

Numeric Display. The large, four-digit display in the VOLTAGE/POWER section is a digital voltmeter that measures and displays the power supply's voltage/power parameters. If the CW is operating with output power turned off, this meter displays the voltage that the output will assume when it is turned on.

VOLTAGE MODE Lamp. This LED, located directly over the numeric display, indicates that the power supply is operating in the constant output voltage mode. This is the most common operation mode used. If the output current rises above the level set by the current program level, this lamp turns off and the CURRENT MODE lamp turns on.

V RANGE Button. This button allows you to select the 0V–135V range or the 0V–270V range of output voltage. The High or Low LED indicates the currently selected voltage range. The output current available on the low voltage range is twice that available on the high voltage range.

LEDs. The indicator lights on the right side of the VOLTAGE/POWER section (VOLTS, WATTS, VA, PF, OVP) identify the currently displayed measurement during the Program and Measure functions.

MEASURE Button. Use this button to specify what measurement is displayed. As you press the button repeatedly to cycle through the parameters, the associated LED illuminates to indicate the measurement shown in the four-digit display. The MEASURE lamp is illuminated when using the Measure function.

PROGRAM Button. Press this button to change the output voltage or OVP setpoint. The PROGRAM lamp is illuminated when using the Program function.

Rotary Knob. This large, multi-turn knob allows you to easily select the desired power supply voltage/power parameters.

③ MENU/STATUS Section

These controls and indicators, located in the center of the front panel, are used to make changes to non-displayed system parameters.

ENTER/SAVE Button. Press this button to enter the Menu system in order to display and/or make changes to the system parameter settings. After specifying the new setting, press this button again to accept and apply the change to the currently selected parameter.

To modify more than one item in the menu system, press ENTER/SAVE after each parameter modification once to save the change, and once more to re-enter the menu system.

ESCAPE Button. Press this button to exit the Menu function without saving parameter changes. Note that this button only abandons the change to the currently selected parameter; previous parameter modifications that were completed using the ENTER/SAVE button are unaffected.

REMOTE Lamp. When lit, this lamp indicates remote programming is enabled. When flashing, this lamp indicates that a remote programming error has been encountered. To clear, touch a PROGRAM key or send the “*RST” over the command interface.

LOCKOUT Lamp. When lit, this lamp indicates that the front panel PROGRAM buttons are locked out.

FAULT Lamp. When lit, this lamp indicates that a fault condition has been detected, and that the system output has been turned off automatically. Some conditions that cause this to occur include: output over-voltage, output over-current, high internal temperature, or an internal system failure.

④ **CURRENT/FREQUENCY Section**

These controls and indicators, located on the right side of the front panel, are used to select and display the current limit and frequency setpoints.

Numeric Display. The large, four-digit display in the CURRENT/FREQUENCY section shows the currently selected measurement.

CURRENT MODE Lamp. This lamp, located directly over the numeric display, indicates when the output current has reached its selected limiting value, i.e., the power supply is operating in the constant current mode.

LEDs. The indicator lights on the left side of the CURRENT/FREQUENCY section (AMPS, Hz, Pk AMPS, CF, I LIMIT) identify the currently displayed measurement during the Program and Measure functions.

MEASURE Button. Use this button to specify what measurement is displayed. As you press the button repeatedly to cycle through the parameters, the associated LED illuminates to indicate the measurement shown in the four-digit display. The MEASURE lamp is illuminated when using the Measure function.

PROGRAM Button. Press this button to change the current limit and frequency setpoints. The PROGRAM lamp is illuminated when using the Program function.

Rotary Knob. This large, multi-turn knob allows you to easily select the desired power supply current/frequency parameters.

⑤ OUTPUT Section

This section is used to open and close the output relay. Output terminals are available in the universal AC connector located in the OUTPUT section, as well as on the rear panel of the CW unit.

Output ON Lamp. When lit, this lamp indicates that the CW output relay has been set to the on position, and power is on the output terminals.

Output OFF/RESET Button. This switch allows you to energize or de-energize the output terminals of the power supply. *If the unit is operating in the fault mode, and if the fault condition has cleared, then cycling this switch will restore normal operation.*

3.2 Front Panel Overview

After performing the power-up operations, the CW reads storage location 0 for the voltage range and the five program values. The CW enters into left and right measure modes. The VOLTS LED on the left, and the AMPS LED on the right will be illuminated and the measured volts and measured amps will be displayed.

Specify which measurement to display in the VOLTAGE/POWER section of the front panel by pressing the left MEASURE button until the VOLTS, WATTS, VA, PF, or OVP appears on the left display. The relevant LED will be illuminated.

Press the right MEASURE button to specify which parameter, AMPS, Hz, Pk AMPS, CF, or I LIMIT, is displayed in the CURRENT/FREQUENCY section of the front panel. The relevant LED will be illuminated.

Press the left PROGRAM button to program the left side Voltage or OVP setpoints. Once in Program mode, the last program operation is automatically re-entered, the relevant LED is lit, and the display changes to indicate the program value that is selected to change. If the PROGRAM button is pressed again, the next programmable setpoint parameter is displayed and the relevant LED is lit to announce the new selection. While the PROGRAM LED is illuminated, turn the rotary knob to change the displayed parameter. As the knob is rotated, the parameter is increased or decreased in value. The change made to the programmable parameter overrides the original value.

The CW output is opened and closed by pressing the OFF/RESET button in the OUTPUT section of the front panel. The ON LED is illuminated when the output is closed.

The voltage range is changed from High to Low or vice-versa by pressing the V RANGE button when the left Program Volts mode is selected. When the range is changed, the voltage is programmed to 0, the output relay will open if it is closed, and the left section will remain in voltage program mode. The HIGH or LOW LED is illuminated to indicate the presently selected range.

Enter the menu system, detailed in Section 4.3, by pressing the ENTER/SAVE button once. After displaying and changing a menu parameter, press ENTER/SAVE again to accept and apply the change. To change more than one item in the menu system, press ENTER/SAVE after each parameter modification once to save and once to re-enter the menu system. Press the ESCAPE button to abandon the present change without saving. Once you have saved or abandoned your changes, the menu system is exited and the displays revert to the measurements previously specified.

3.3 Power Up

At power-up the CW software will:

- Place “STBY 1.xx” on the displays. The number on the right is the version of the boot eprom software.
- Displays “TEST x.xx” while the CW performs the self test functions. The rightmost number is the version of the CW firmware application.
- Requests self test data from any attached and properly configured slaves in a master-slave configuration.
- Displays “PASS x.xx” or “FAIL x.xx” to report the results of the testing.
- Upon passing the tests, the CW will read in the 0th system parameter set from EEPROM memory and the CW (and any attached slaves) will be configured in accordance with these parameters.
- If the CW has been configured previously to autostart after power cycle, the output relay will close. If the CW is the master of a set of CW units, all relays will be commanded to close.
- The VOLTAGE/POWER section of the front panel will now display measured volts. The MEASURE and VOLTS LEDs will be illuminated. The V RANGE LED will be lit according to the range recalled from location 0.
- The CURRENT/FREQUENCY section will display the measured current. The MEASURE and AMPS LEDs will be illuminated.
- If the unit fails self test, the display will read “FAIL x.xx” and the output relay will be inoperable.

3.4 Programmed Frequency Steps

The allowed frequency delta for programmed frequency steps is a function of programmed output voltage and phase angle for models with the V-Option. At programmed phase angles greater than 90° , and programmed output voltage greater than 270 VRMS, the allowed frequency step is 45–500 Hz. At programmed phase angles greater than 90° , and programmed output voltage of 310 VRMS, the allowed frequency step is reduced to 45–250 Hz. Exceeding the allowed frequency step could result in a fault shutdown of the unit.

SECTION 4

PROGRAMMING

4.1 Programming the CW Via the Front Panel

Press the PROGRAM button in the VOLTAGE/POWER section to enter Program mode. The PROGRAM LED lights up and the last programmed value appears in the digital display. The associated LED lights to show which item (voltage or overvoltage) is being programmed. The rotary knob will be active and any change made to the setpoint being adjusted is final as it is made. Press any button to exit the Program mode.

Front panel button functions are as follows:

- If the PROGRAM button is pressed, the CW moves the program focus to the next program item in line.
- If a MEASURE button is pressed, the CW reverts to the previous Measurement mode without changing the measurement focus.
- If the V RANGE button is pressed while in Program Voltage mode, the CW performs a range change operation and the VOLTAGE/POWER section remains in Program Voltage mode.
- If the ENTER/SAVE button in the MENU/STATUS section is pressed, the menu system appears on the display.
- If the ESCAPE or ENTER/SAVE button in the MENU/STATUS section is pressed when in the menu system, menu operations are terminated and Measurement mode is re-entered.
- If there is no front panel activity for 10 seconds while in Menu or Program modes, the CW reverts to the Measure modes. The PROGRAM and programmed parameter LEDs turn off, and both MEASURE LEDs are lit.
- By rotating the programming knobs slowly, the changing parameter steps up/down in small steps. By increasing the rotation speed of the knob, an “acceleration” algorithm will increase the size of the changed value granularity and the parameter will increase/decrease faster.

4.1.1 VOLTAGE/POWER Section

Change Voltage Range

To change the voltage range from High to Low or vice-versa, press the V RANGE button after pressing PROGRAM. The output relay will open (if it was closed) and the voltage will be set to 0. The unit will remain in program voltage mode to allow reprogramming of the voltage.

Program Output Voltage Setpoint

Press the left PROGRAM button repeatedly until the VOLTS LED is illuminated. Rotate the left knob until the display reads the voltage that is desired. The output will change to source this displayed voltage.

Program Overvoltage Setpoint

Press the left PROGRAM button repeatedly until the OVP LED is illuminated. Rotate the left knob until the display reads the over-voltage setpoint that is desired. The output terminals will be protected for overvoltage sensed at or above this displayed voltage.

4.1.2 CURRENT/FREQUENCY Section

Program Current Limit

Press the right PROGRAM button repeatedly until the AMPS LED is illuminated. Rotate the right knob until the display reads the current limit setpoint that is desired. The output terminals will foldback or shutdown (user-selectable) at or above the displayed value. See Section 4.3.3.

Program Frequency

Press the right PROGRAM button repeatedly until the Freq LED is illuminated. Rotate the right knob until the display reads the frequency setpoint that is desired. The output terminals will source AC at the displayed frequency setpoint.

4.2 Measurement Operations

4.2.1 Supply Measurements on the Left Display

To change which item is displayed at measure time, press MEASURE repeatedly until the desired LED is illuminated.

Measured Output Voltage

When the left MEASURE and the VOLTS LEDs are illuminated, the output voltage is displayed on the left display.

Measured Wattage

When the left MEASURE and the WATTS LEDs are illuminated, the wattage being sourced at the output terminals is displayed on the left display.

Displaying Overvoltage Setpoint

When the left MEASURE and the OVP LEDs are illuminated, the over-voltage setpoint is displayed on the left display.

Measured Volt-Amps

When the left MEASURE and the VA LEDs are illuminated, the apparent power, in volt-amps, being sourced at the output terminals is displayed on the left display.

Measured Power Factor

When the left MEASURE and the PF LEDs are illuminated, the power factor measured at the output terminals is displayed on the left display.

4.2.2 Supply Measurements on the Right Display

To change which item is displayed at measure time, press MEASURE repeatedly until the desired LED is illuminated.

Measured Current

When the right MEASURE and the AMPS LEDs are illuminated, the RMS current measured at the output terminals is displayed on the right display.

Measured Frequency

When the right MEASURE and the Hz LEDs are illuminated, the frequency measured at the output terminals is displayed on the right display.

Instantaneous Peak Current

When the right MEASURE and the Pk AMPS LEDs are illuminated, the instantaneous peak current is displayed on the right display.

Measured Crest Factor

When the right MEASURE and the CF LEDs are illuminated, the crest factor measured at the output terminals is displayed on the right display.

Note: *When the output current is less than 5% of the full rated current, the crest factor is not applicable.*

The SLAVECONFIG parameter only applies if the SLAVEADDR is set to 0 and the SLAVECHAN is set to A on the A master unit. Only the A phase master uses this parameter.

4.3 Menu Operations

There are two buttons in the Menu section of the front panel, ENTER/SAVE and ESCAPE. Press the ENTER button to enter the Menu system. The MENU/STATUS LED lights and the left and right displays are overridden to provide menu system readouts. When in the Menu mode, the two MEASURE and two PROGRAM LEDs are all turned off.

Use the Menu system to display and/or change the following parameters:

- Check the self-test result
- Set the GPIB port address
- Specify current Foldback/Shutdown
- Specify current shutdown delay
- Specify PROGRAM keys lock out
- Store system parameters
- Recall system parameters
- Specify whether the output relay will automatically close at power-up
- Specify Clock Signal as an Input or an Output
- Analog input
- RMS loop On/Off
- Phase A offset
- Phase B offset
- Phase C offset
- Slave channel
- Slave address
- Slave configuration

The menu is flat in its design and the various major nodes are available by rotating the left knob either clockwise or counterclockwise to move either down or up on the list given here.

The Menu LED is used to indicate if changes have been introduced into the menu system. If there have been no changes, the LED will light steadily. If the operator has introduced some change to a menu variable, the LED will blink.

The Menu LED is illuminated steadily when the menu system is entered, indicating that nothing has yet been changed. When the LED is lit steadily, the ENTER/SAVE and ESCAPE buttons perform the same action, that being the menu system will be exited when either one is pressed.

When the menu item to be changed is selected with the left rotary knob, use the right rotary knob to change the specific parameter selected. When you make any change to a menu parameter with the right knob, the MENU LED blinks, and the left knob is locked out. Press the ENTER/SAVE button to accept and save the change; press the ESCAPE button to cancel the change. If the parameter is returned to its present original value with the right knob, the left knob is again enabled and the MENU LED returns to a steady On state.

If the ESCAPE button is pressed while the Menu LED is blinking, any unsaved change made to the menu parameter will be lost, and the CW will revert to the measurement mode.

When using the menu system, if you stop pressing buttons or turning knobs for more than 20 seconds, the CW will revert to measurement mode and any menu changes will be lost.

4.3.1 Self Test

This menu item reports the outcome of the power-on self-test. If the result is PASS, then all system operations are available. If the result is FAIL, both displays will read FAIL nnnn. Following a self-test failure, the output relay cannot be closed and the quantity of slaves, attached phases, and/or calibration inaccuracies can be corrected if these were the cause of the FAIL status. You can press either the ESCAPE or the ENTER/SAVE button to continue (without the output relay closure possible) to correct a configuration error, if it is only configuration. If the failure is due to a non-configurable item, the CW will need to be repaired.

STST PASS, FAIL

4.3.2 Set GPIB Port

This menu item allows the GPIB address to be set. The GPIB address will initially be set to 25 at the factory. The range is 1 to 31.

GPIB nn (e.g., 23)

4.3.3 Specify Current Limit Type

This menu item specifies whether the CW will shut down after a delay or fold back voltage to maintain the presently set current at the output terminals.

CURR SHUT,FOLD

4.3.4 Specify Shutdown Delay

This menu item specifies the amount of time that the CW will fold back before shutting down when the current is exceeded and the above mode is in shutdown mode. The range is 0 to 3000 milliseconds.

CDLY nnn (e.g., 200)

4.3.5 Specify Program Keys Locked Mode

This menu item specifies whether the PROGRAM buttons will be operable. When the PROGRAM buttons are locked, this is the only menu item that operates.

PROG ENA,DIS

4.3.6 Store Present Machine Settings

This menu item, when saved (not cancelled) by the user, will gather up any changes made while in the menu system and save them along with the present system state to the dialed in memory location. Valid memory locations are 0 to 98.

STO nn

System Parameters Saved and Recalled:

- Volts
- Frequency
- Current Limit
- Current Limit Type (Shut, Fold)
- Current Limit Shutdown Time
- Voltage Range (Low, High)
- Overvoltage
- Analog Input on/off
- Clock signal direction input/output

4.3.7 Recall Machine Settings

This menu item, when saved (not cancelled) by the user, will recall to the present system the system state that was saved in the dialed in memory location. Valid memory locations are 0 to 99.

RCL nn

System state number 99 is the factory default state. The following are the default factory settings:

- Volts: 0.0
- Frequency: 60
- Current Limit: MAX
- Current Limit Type (Shut, Fold): FOLDBACK
- Current Limit Shutdown Time: 200 ms
- Voltage Range: LOW
- Overvoltage: MAX
- Analog Input: OFF
- Clock Signal Direction: OUT

4.3.8 Specify Relay State After Power Up Initialization

This menu item specifies whether the CW automatically closes its output relay as soon as power up self-test succeeds. In RUN mode, the relay automatically closes, as does any properly-specified and connected slaves.

INIT RUN, STBY

4.3.9 Clock Direction

This menu item specifies whether the clock line is used as a zero crossing indication or a phase-locked-loop signal source.

CLOC OUT/IN

4.3.10 Analog Input State

This menu item specifies if an analog input signal, as applied to the M/S IN connector, will be used as the programming source for the output voltage, adjusting it from zero to a maximum value set by the front panel controls or through GPIB/RS-232 commands.

AINP OFF/ON

4.3.11 RMS Voltage Loop

This entry specifies whether the RMS voltage loop is on or off. When the voltage loop is turned on, the RMS output voltage is tightly regulated at the sense point and the output impedance is compensated for. When the voltage loop is off, the output impedance is not compensated for.

LOOP OFF/ON

4.3.12 Phase A Offset

This setting specifies the offset of the phase A output zero crossing in relation to the externally applied phase-lock-loop signal in degrees.

CLPH 0..360

4.3.13 Phase B Offset

This setting specifies the offset of the phase B waveform in relation to the phase A waveform in degrees.

PHB 0..360

4.3.14 Phase C Offset

This setting specifies the offset of the phase C waveform in relation to the phase A waveform in degrees.

PHC 0..360

4.3.15 Slave Channel

Refer to Section 2.9, *Master/Slave Configurations*, for usage.

CHAN A, B, or C

4.3.16 Slave Address

Refer to Section 2.9, *Master/Slave Configurations*, for usage.

ADDR 0..5

4.3.17 Slave Configuration

Refer to Section 2.9, *Master/Slave Configurations*, for usage.

CONF A0A0–A0C5

SECTION 5 MAINTENANCE

5.1 Periodic Service

No routine maintenance on the CW Series unit is required, aside from periodic cleaning.

Once a unit is removed from service, it may be cleaned with isopropyl alcohol (or an equivalent solvent) on the metal surfaces, and a weak solution of soap and water on the front panel.

Remove dust from in and around components on the printed circuit boards, taking suitable measures to control electrostatic discharge (ESD).

5.2 Fuse Replacement

Replacement fuses for the CW Series supply are listed below in Table 5–1.

Ref. Designator	Location	Rating	Manufacturer	Mfr. P/N	Elgar P/N
F1, F2	Motherboard	25A, 250V, T	Bussmann	MDA-V-25	858-325-25
F3	Motherboard	1A, 250V, T	Bussmann Littelfuse	C515-1A 230-001S	858-250-11 858-250-11
F4 (CW 801P, CW 1251P)	Motherboard	10A, 600V DC	Littelfuse	KLKD10	858-601-10
F4 (CW 2501P)	Motherboard	15A, 600V DC	Littelfuse	KLKD15	858-601-15

Table 5–1 Replacement Fuses



CAUTION! Fuse replacement should be performed only by qualified service personnel. Breaking the quality seal will invalidate the warranty.

This page intentionally left blank.