



## MODEL 9210D

# LOW FREQUENCY PORTABLE VIBRATION CALIBRATOR

- Verify Alert and Alarm Settings
- Simulate Vibration at Actual Running Speeds
- Rugged, Lightweight, and Battery-Powered Design
- On-Site ISO 5041 HVM Calibrations
- Ensure Accuracy of Critical Structural Tests
- Proximity Probe Adaptor Kit

## TYPICAL APPLICATIONS

- Hydro and Nuclear Power
- Human Vibration Measurement
- Seismic, Building Vibration
- Moving Coil Vibration Sensors
- Condition Monitoring System, Process Control, DCS and SCADA
- Portable Vibration Meters and Analyzers

## REDUCE PERCEIVED RISK

The 9210D Low Frequency Portable Vibration Calibrator is the world's first and only ISO 17025-accredited, NIST-traceable portable vibration calibrator capable of creating calibration certificates for critical instrumentation used to protect slow speed rotating equipment. Until now, technicians were required to remove moving coil velocity sensors, low frequency accelerometers and proximity probes during an outage and send these instruments to a separate lab for calibration. Battery-powered, rugged and portable, the Model 9210D brings low frequency calibration to the plant floor, allowing users to verify all aspects of their measurement chain, confirm correct operation of critical alarm thresholds, and create a printable, traceable calibration records.

Immediate instrument verification is available via sensitivity display on the brightly lit LCD screen. The test sensor input supplies ICP® power or can be toggled to voltage mode, allowing the unit to calculate sensitivity and create calibration certificates for Eddy current probes and moving coil velocity sensors. ISO 17025-compliant calibration certificates are created via Microsoft® Excel macro for both linearity and frequency response.

An internal high-resolution quartz reference accelerometer provides unparalleled accuracy while the rugged carbon fiber composite armature supports heavy payloads. A durable Pelican® Storm Case and long battery life make it ideal for use on the plant floor. Closed-loop control shortens calibration time. The 9210D can be scaled in displacement, velocity or acceleration (metric or English units) with 0.7 Hz to 2 kHz frequency range (42 to 120 000 CPM).

SPECIFICATIONS		
<b>Performance</b>		
Frequency Range (operating, 100 gram payload)	0.7 Hz to 2 kHz	42 to 120k C
Maximum Amplitude (100 Hz with no payload)	2 g pk	305 m/s <sup>2</sup> pk
	12 in/s pk	305 mm/s pk
	200 mils pk-pk	5 mm pk-pk
Maximum Payload <sup>[1]</sup>	800 grams	
Acceleration and Velocity (2 Hz to 2 kHz) <sup>[2] [7]</sup>	±3 %	
Acceleration and Velocity (0.7 Hz to 2 kHz) <sup>[2] [7]</sup>	±10 %	
Displacement (3 Hz to 15 Hz) <sup>[3]</sup>	±3 %	
Displacement (1 Hz to 150 Hz) <sup>[3]</sup>	±10 %	
Displacement (0.7 Hz to 150 Hz) <sup>[3]</sup>	±2 dB	
Amplitude Linearity (100 gram payload, 100 Hz)	< 1 % up to 2 g pk	
Waveform Distortion (1 Hz to 5 Hz)	Typically < 15 %	
Waveform Distortion (>5 Hz to 20 Hz)	Typically < 10 %	
Waveform Distortion (>20 Hz to 2 kHz)	Typically < 7 %	
Acceleration (peak and RMS)	g	m/s <sup>2</sup>
Velocity (peak and RMS)	in/s	mm/s
Displacement (peak to peak)	mils	µm
Frequency	Hz	CPM
Test Sensor Sensitivity	mV	EU <sup>[4]</sup>
<b>Physical</b>		
Test Sensor In	Voltage	ICP <sup>®</sup> <sup>[5]</sup>
Test Sensor Input Voltage	20 mV–10 V AC pk-pk	
Bias Fault Indication (ICP <sup>®</sup> Sensors)	Yes	
External Source In (max)	1 V AC RMS	
Monitor Reference Out	100 mV/g buffered internal reference output	
Internal Battery (sealed solid gel lead acid)	12 VDC, 4 amp hours	
AC Power (for recharging battery)	110–240 VDC, 50–60 Hz	
Input Power Rating from charger	18 VDC, 1 A	
Operating Battery Life <sup>[6]</sup>		
100 gram payload (100 Hz 1 g pk)	14 hours	
100 gram payload (1 Hz 0.02 g pk)	7 hours	
Operating Temperature	32 °F–122 °F	0 °C–50 °C
Dimensions (H x W x D)	8.5 x 12 x 10 in	22 x 30.5 x 28 cm
Weight	18 lb	8.2 kg
Sensor Mounting Platform Thread Size	¼-28	¼-28
Integral Armature Lock	Supplied	

Optional Accessories	
<b>9105C</b>	Transfer standard reference accelerometer and ICP <sup>®</sup> sensor signal conditioner, for calibration and system verification of the 9200 Series Calibrators.
<b>9100-MPPA01</b>	Proximity probe adaptor kit, supports probes with common case threads ranging from M6 to ½ in. Includes Mitutoyo micrometer (metric) and 9100-PPA02 nickel-plated 4140 steel target.
<b>9100-PPA01</b>	Proximity probe adaptor kit, supports probes with common case threads ranging from M6 to ½ in. Includes Mitutoyo micrometer and 9100-PPA02 nickel-plated 4140 steel target.
Accessory Pouch	
Power Supply and Plug Adaptors, ¼-28 to ¼-28 Adaptor, 10-32 to ¼-28 Adaptor and Mounting Pad. Ships with shipping lock (remove before use). USB Flash Drive with Calibration Report Generation Worksheet.	



**Hydropower Plant**

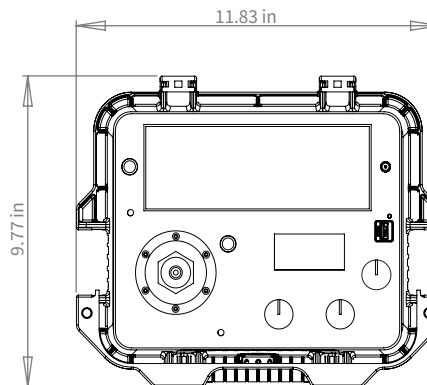

**Model 9210D**  
Technical Drawing

- [1] Operating range reduced at higher payloads. Reference manual for full details.
- [2] Measured with 30 gram quartz reference accelerometer.
- [3] Measured with laser displacement interferometer.
- [4] EU can be [g], [m/s<sup>2</sup>], [in/s], [mm/s], [mils] or [µm].
- [5] 5 mA constant current excitation to ICP<sup>®</sup> (IEPE) sensor.
- [6] As shipped from factory in new condition.
- [7] Depending upon payload at higher frequencies transverse motion may cause localized increased measurement uncertainty.

## THE MODAL SHOP

MTS SYSTEMS CORPORATION

3149 E Kemper Rd, Cincinnati, OH 45241 USA

Toll-Free in the USA: 800 860 4867

Phone: 1 513 351 9919 | Email: info@modalshop.com

The Modal Shop, Inc. offers structural vibration and acoustic sensing systems and services for various applications in design and test laboratories as well as manufacturing plants. An extensive sound and vibration rental program, precision calibration systems, and both modal and vibration shakers are designed to simplify test phases. Non Destructive Testing Systems help manufacturers provide 100% quality inspection of metal components. The Modal Shop, Inc. is a subsidiary of PCB Piezotronics, Inc., and PCB<sup>®</sup> is a wholly owned subsidiary of MTS Systems Corporation.

© 2019 The Modal Shop, Inc. In the interest of constant product improvement, specifications are subject to change without notice. PCB<sup>®</sup>, ICP<sup>®</sup>, Swiveler<sup>®</sup>, Modally Tuned<sup>®</sup>, and IMI<sup>®</sup> with associated logo are registered trademarks of PCB Piezotronics, Inc. in the United States. ICP<sup>®</sup> is a registered trademark of PCB Piezotronics Europe GmbH in Germany and other countries. UHT-12<sup>™</sup> is a trademark of PCB Piezotronics, Inc. SensorLine<sup>™</sup> is a service mark of PCB Piezotronics, Inc. SWIFT<sup>™</sup> is a registered trademark of MTS Systems Corporation in the United States. All other trademarks are property of their respective owners.

DS-0140 revC



MTS Sensors, a division of MTS Systems Corporation (NASDAQ: MTSC), vastly expanded its range of products and solutions after MTS acquired PCB Piezotronics, Inc. in July, 2016. PCB Piezotronics, Inc. is a wholly owned subsidiary of MTS Systems Corp.; IMI Sensors and Larson Davis are divisions of PCB Piezotronics, Inc.; Accumetrics, Inc. and The Modal Shop, Inc. are subsidiaries of PCB Piezotronics, Inc.