



Advanced Test Equipment Rentals
www.atecorp.com 800-404-ATEC (2832)

ELGAR
OPERATING MANUAL

for the

AC POWER SOURCE

MODEL 501SX/1001SX/1751SX

ELGAR CORPORATION
9250 Brown Deer Road
San Diego, CA 92121

AC POWER SOURCES
SX Series - Operation

©1993 ELGAR CORPORATION

This document contains information proprietary to ELGAR Corporation. The information contained herein is not to be duplicated nor transferred in any manner without prior written permission from ELGAR Corporation.

Document No. M071032-01G

March 18, 1993

SAFETY NOTICE

BEFORE APPLYING POWER to the System, verify that the Model 501SX/1001SX/1751SX AC Power Source is properly configured for the user's particular application.

WARNING

Hazardous voltages in excess of 280 VAC, 396V Peak may be present at the INPUT POWER and OUTPUT POWER terminal blocks. Qualified personnel must use EXTREME CAUTION when configuring or servicing this equipment. Circuit boards, test points and output voltages may also be floating above (below) chassis ground. Internally, in addition to the voltages mentioned above, DC power supply voltages of ± 50 VDC are present. These DC voltages are capable of short circuit currents of up to several hundred amperes.

Installation and servicing must be performed by QUALIFIED PERSONNEL who are aware of properly dealing with attendant hazards.

Ensure that the AC power line ground is properly connected to the Model 501SX/1001SX/1751SX AC Power Source input terminal. Similarly, other power ground lines including those to application and maintenance equipment **MUST** be properly grounded for both personnel and equipment safety.

Always ensure that facility AC input power is de-energized prior to connecting or disconnecting the power cable. Similarly, the Model 501SX/1001SX/1751SX AC Power Source circuit breaker must be switched OFF prior to connecting or disconnecting output power.

Always ensure that the input AC power has been de-energized when connecting or disconnecting power or loads at the rear panel INPUT POWER or OUTPUT POWER terminal blocks. Ensure that a power line ground connection is made to the INPUT POWER terminal block when connecting input power.

In normal operation, the operator does not have access to hazardous voltages within the chassis. However, depending on the user's application configuration, **HIGH VOLTAGES HAZARDOUS TO HUMAN SAFETY** may be normally generated on the output terminals. The Customer/User must ensure that the output power (and sense) lines be properly labeled as to the SAFETY hazards and any that inadvertent contact with hazardous voltages is eliminated.

Guard against risks of electrical shock during open cover checks by **NOT TOUCHING** any portion of the electrical circuits. Even when power is OFF, capacitors may retain an electrical charge. Use SAFETY GLASSES during open cover checks to avoid personal injury by any sudden component failure.

	<u>Page</u>
Warranty	i
Safety Notice	ii
Table of Contents	iii

SECTION I - GENERAL DESCRIPTION

1.1 INTRODUCTION	1-1
1.2 SINGLE PHASE UNIT IDENTIFICATION	1-3
1.3 SYSTEM CONFIGURATIONS	1-3
1.4 SPECIFICATIONS	1-6
1.4.1 Model 501SX Specifications	1-6
1.4.1.1 Output Characteristics	1-6
1.4.1.2 Input Characteristics	1-8
1.4.1.3 ATE Features	1-9
1.4.1.4 General	1-9
1.4.2 Model 1001SX Specifications	1-10
1.4.2.1 Output Characteristics	1-10
1.4.2.2 Input Characteristics	1-12
1.4.2.3 ATE Features	1-12
1.4.2.4 General	1-12
1.4.3 Model 1751SX Specifications	1-13
1.4.3.1 Output Characteristics	1-13
1.4.3.2 Input Characteristics	1-15
1.4.3.3 ATE Features	1-15
1.4.3.4 General	1-15

SECTION II - INSTALLATION

2.1 INTRODUCTION	2-1
2.2 UNPACKING	2-1
2.3 PRE-INSTALLATION INSPECTION	2-2
2.4 OPTIONS	2-2
2.4.1 Input Voltages	2-2
2.4.2 Output Voltages	2-2
2.4.3 Oscillators	2-5
2.4.4 Other Options	2-5
2.4.4.1 "-T" Option	2-5
2.4.4.2 "-D" Option	2-5
2.4.4.3 "-S" Option	2-5
2.4.4.4 Range Change Option	2-5

	<u>Page</u>
2.5 MODEL 501SX INSTALLATION	2-12
2.5.1 Input Power Requirements	2-12
2.5.2 Output Power Connections	2-12
2.5.3 Sync Out BNC Connectors	2-12
2.5.4 Installing The Model 751SL/1001SL	2-12
2.5.5 Model 501SX Preliminary Functional Checkout	2-13
2.6 MODEL 1001SX INSTALLATION	2-17
2.6.1 Input Power Requirements	2-17
2.6.2 Output Power Connections	2-17
2.6.3 Sync Out BNC Connectors	2-17
2.6.4 Installing The Model 1001SX	2-17
2.6.5 Model 1001SX Preliminary Functional Checkout	2-18
2.7 MODEL 1751SX INSTALLATION	2-22
2.7.1 Input Power Requirements	2-22
2.7.2 Output Power Connections	2-22
2.7.3 Sync Out BNC Connectors	2-22
2.7.4 Installing The Model 751SL/1001SL	2-22
2.7.5 Model 1751SL Preliminary Functional Checkout	2-23
2.8 SYSTEM INTERCONNECTION	2-27
2.8.1 Multi-Phase Operation	2-27
2.8.2 Model 400SR Configuration Switch	2-30
2.8.3 Model 400 Series Plug-In Oscillators	2-32
2.8.3.1 Model 400A	2-32
2.8.3.2 Model 400B	2-32
2.8.3.3 Model 400C	2-32
2.8.3.4 Model 400DPA	2-32
2.8.3.5 Model 400DPB	2-37
2.8.3.6 Model 400DPC	2-37
2.8.3.7 Model 400BT	2-37
2.8.4 Interconnect Diagrams	2-37

	<u>Page</u>
SECTION III - OPERATION	
3.1 INTRODUCTION	3-1
3.2 MANUAL OPERATION	3-1
3.3 GPIB OPERATION	3-1
3.4 CONTROLS AND INDICATORS	3-1
3.4.1 Output Voltage Meter	3-1
3.4.2 Oscillator Cavity	3-1
3.4.3 POWER On Switch-Circuit Breaker	3-1
3.4.4 POWER On Indicator	3-1
3.4.5 AMPLITUDE Adjustment Screw	3-2
3.5 OPERATING INSTRUCTIONS	3-2
3.5.1 Power ON	3-2
3.5.2 Frequency Control	3-2
3.5.3 Amplitude Control	3-2

LIST OF APPENDIXES

A	Wire Gauge Selection	A-1
B	Configuration and Functional Verification Checksheet	B-1

LIST OF FIGURES

1-1	Power Output Derating	1-2
1-2	SX Series Single Phase Model Identification Information	1-4
1-3	SX Series Multi-Phase Model Identification Information	1-5
2-1	Input Voltage Options	2-3
2-2	Output Voltage Options	2-4
2-3	Output Monitoring Option	2-6
2-4	Output Monitoring and 130V/260V Ranging Options	2-7
2-5	Output Monitoring and 65V/130V/260V Ranging Options	2-8
2-6	Output Monitoring and 65V/260V Ranging Options	2-9
2-7	Output Monitoring, 130V/260V Ranging, and Output Connect/Disconnect Options	2-10
2-8	Model 501SX Installation Dimensions	2-14
2-9	Model 501SX (Front View)	2-15
2-10	Model 501SX (Rear View)	2-16
2-11	Model 1001SX Installation Dimensions	2-19
2-12	Model 1001SX (Front View)	2-20
2-13	Model 1001SX (Rear View)	2-21
2-14	Model 1751SX Installation Dimensions	2-24
2-15	Model 1751SX (Front View)	2-25
2-16	Model 1751SX (Rear View)	2-26
2-17	System Interconnections	2-29
2-18	Open Delta Vector Diagram	2-30
2-19	Model 400SR Configuration Switch, S1	2-31
2-20	Model 400A Signal Routing Plug-In Connections	2-33
2-21	Model 400B Signal Routing Plug-In Connections	2-34
2-22	Model 400C Signal Routing Plug-In Connections	2-35
2-23	Model 400DPA Signal Routing Plug-In Connections	2-36
2-24	Model 400DPB Signal Routing Plug-In Connections	2-38
2-25	Model 400DPC Signal Routing Plug-In Connections	2-39
2-26	Model 400BT Signal Routing Plug-In Connections	2-40
2-27	System Output/Signal Interconnect	2-41
2-28	System Output/Signal Interconnect With -D Option	2-42

Page

LIST OF TABLES

1-1	Multi-Phase System Configurations	1-6
1-2	Model 501SX Effective DC Power Output	1-7
1-3	Model 501SX Output Current	1-7
1-4	Model 1001SX Effective DC Power Output	1-10
1-5	Model 1001SX Output Current	1-11
1-6	Model 1751SX Effective DC Power Output	1-13
1-7	Model 1751SX Output Current	1-14
2-1	Model 501SX/1001SX/1751SX Options	2-11
2-2	1-, 2-, or 3-Phase Using Two or Three AC Power Sources	2-28

1.1 INTRODUCTION

This manual describes the Elgar Model 501SX, Model 1001SX, and Model 1751SX AC Power Sources. This series of power sources are designed to drive non-linear rectifier loads and meets all the electrical power requirements for the testing of modern switch-mode DC power supplies. The 4:1 (or greater) crest factor capability (which provides repetitive peak current up to 70 amps, depending on the model) makes the SX Series ideal for testing any equipment that causes a peak load on the AC power line. Increased peak power capacity and a drastically reduced package size makes this series ideal for benchtop testing and for use in automated DC power supply test systems. Some of the features include:

- Crest Factors Exceed 4:1
- Repetitive Current up to 70 Amps
- MATE Compatible - Embedded TMA
- Programmable Current Limit - Automatic Shutdown and Reporting
- Low Effective Output Impedance
- Continuous Duty at 150% of Rated Capacity
- Programmable Range Changing Relays
- Overload and Over-Temperature Protection
- Three Output Voltage Ranges
- BIT and BITE Capability

- Available in 9 Models - 1, 2, and 3 Phase

Each unit allows incorporation of custom functions without resorting to special designs. These power sources provide AC power at precise frequencies for testing, motor operation, and frequency conversion. The basic power source consists of two DC supplies and a direct coupled amplifier which drives a tapped output transformer.

The output voltage ranges are:

- 0 to 65 VAC;
- 0 to 130 VAC; and,
- 0 to 260 VAC.

Output power at full and at less than full rated voltage is depicted in the derating chart illustrated in Figure 1-1. Each power source can be configured for a 115, 208, or 230 VAC input, 47-63 Hz (380-420 Hz optional), single phase (the Model 501SX does not have a 208 VAC input capability).

RMS output voltage, frequency, load current, output phase angle, true RMS power, and other parameters are controlled by Elgar's fixed, variable, or plug-in programmable (PIP) oscillators. The output frequency range for these units is 45 Hz to 1 kHz. The basic power output is single phase. However, multi-phase outputs may be obtained by stacking two or three power sources, all driven by one multi-phase plug-in oscillator (refer to paragraph 1.3).

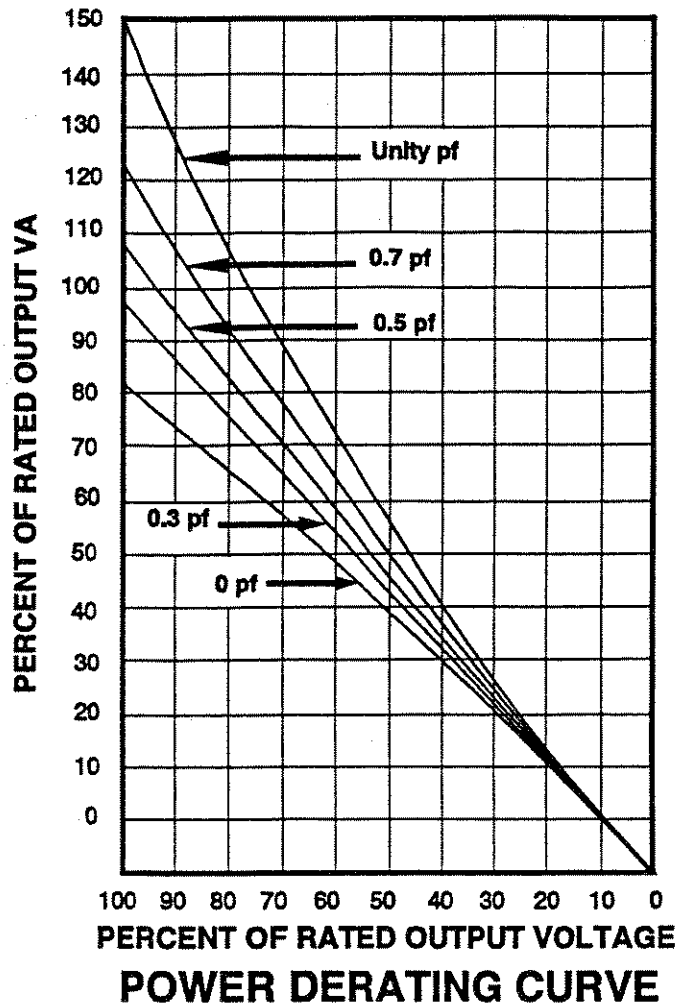

Typical Output VA for Elgar
SL/SX Series AC Power Sources

Conditions

F_{out} = Midband (200 Hz to 500 Hz)

Output Distortion $\leq 0.5\%$

Simultaneous Loading of All Phases
for Multiphase Units.

Input Line = Nominal Value

Figure 1-1. Power Output Derating

The SX Series, when used with an Elgar PIP, can maximize power supply test productivity and improve test quality. Key tests can be performed under program control for repeatability and accuracy:

- Static line regulation and frequency margins;
- Dynamic line regulation to check sudden line drops or missing cycles;
- Start-up time under various line conditions;
- Hold-up time and power sequencing;
- Inrush current testing;
- Ramp-up and ramp-down tests for soft start and power failure signals; and,
- External measurement and test synchronization via a logic pulse.

Each power source is rack mountable. The front panel includes:

- A meter for output voltage monitoring;
- A power ON indicator lamp;
- A voltage amplitude control; and,
- A power circuit breaker.

Cooling air for the power amplifier is drawn through side panel grills and is exhausted at the rear of the enclosure. The enclosure contains heatsink assemblies and includes a two section power amplifier. Control circuitry is mounted on a plug-in circuit board with test points and an adjustment control for output voltage regulation. The output voltage can be monitored at either the rear panel terminal block or the front panel binding posts.

This series of power sources are programmable via the IEEE-488 GPIB and meet all requirements of MATE-STD-280673, including built-in TMA for CIIL/ATLAS interfacing.

1.2 SINGLE PHASE UNIT IDENTIFICATION

Figure 1-2 provides an illustration of the SX Series single phase unit model identification information, including the various available options (refer to Section II for specific option information).

1.3 SYSTEM CONFIGURATIONS

Figure 1-3 and Table 1-1 provide an illustration of the SX Series identification information when used in a system configuration in order to provide two or three output phases with a variety of total output power configurations. Refer to Section II, paragraph 2.7, for further information.

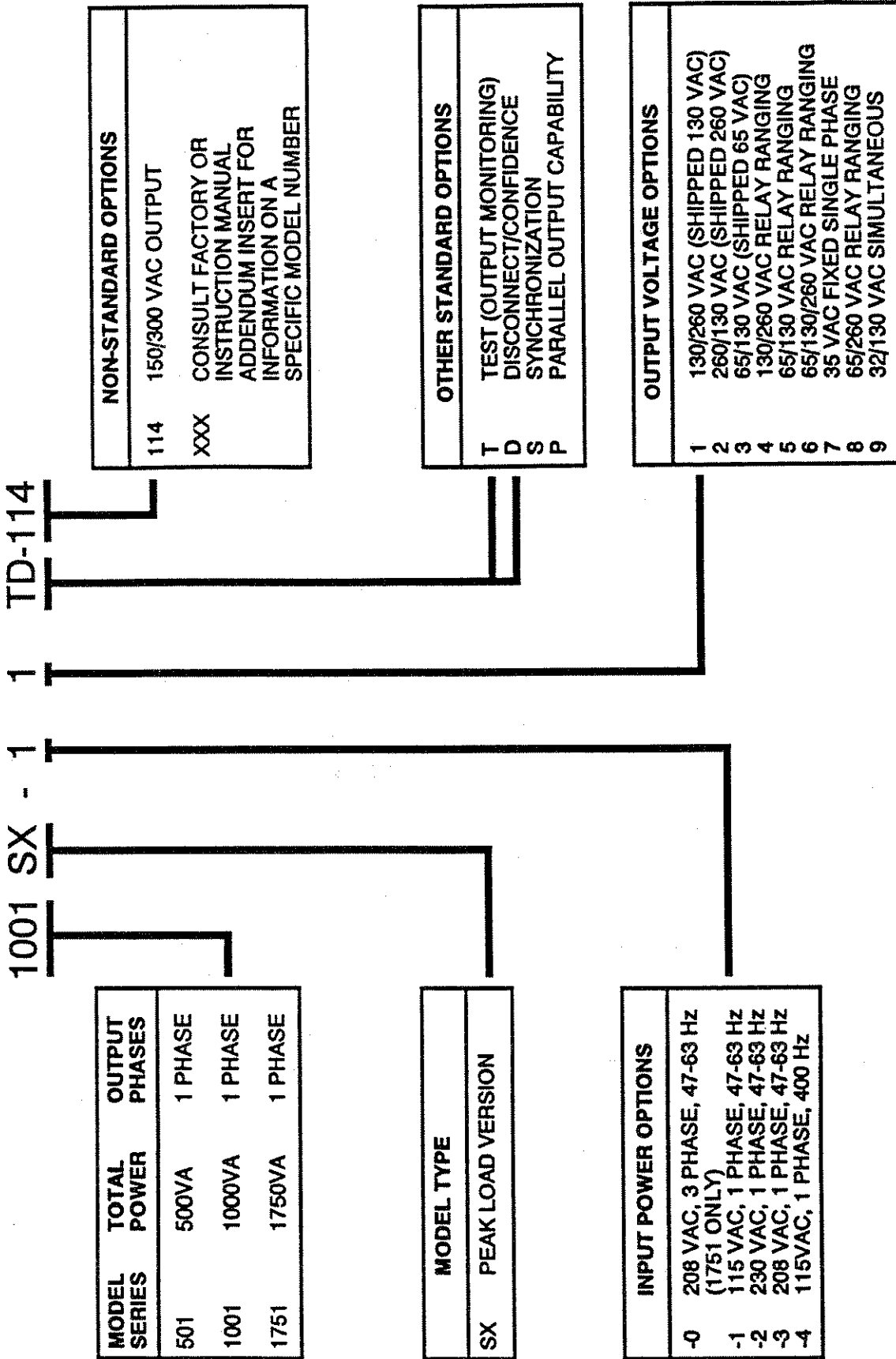

Figure 1-2. SX Series Single Phase Model Identification Information

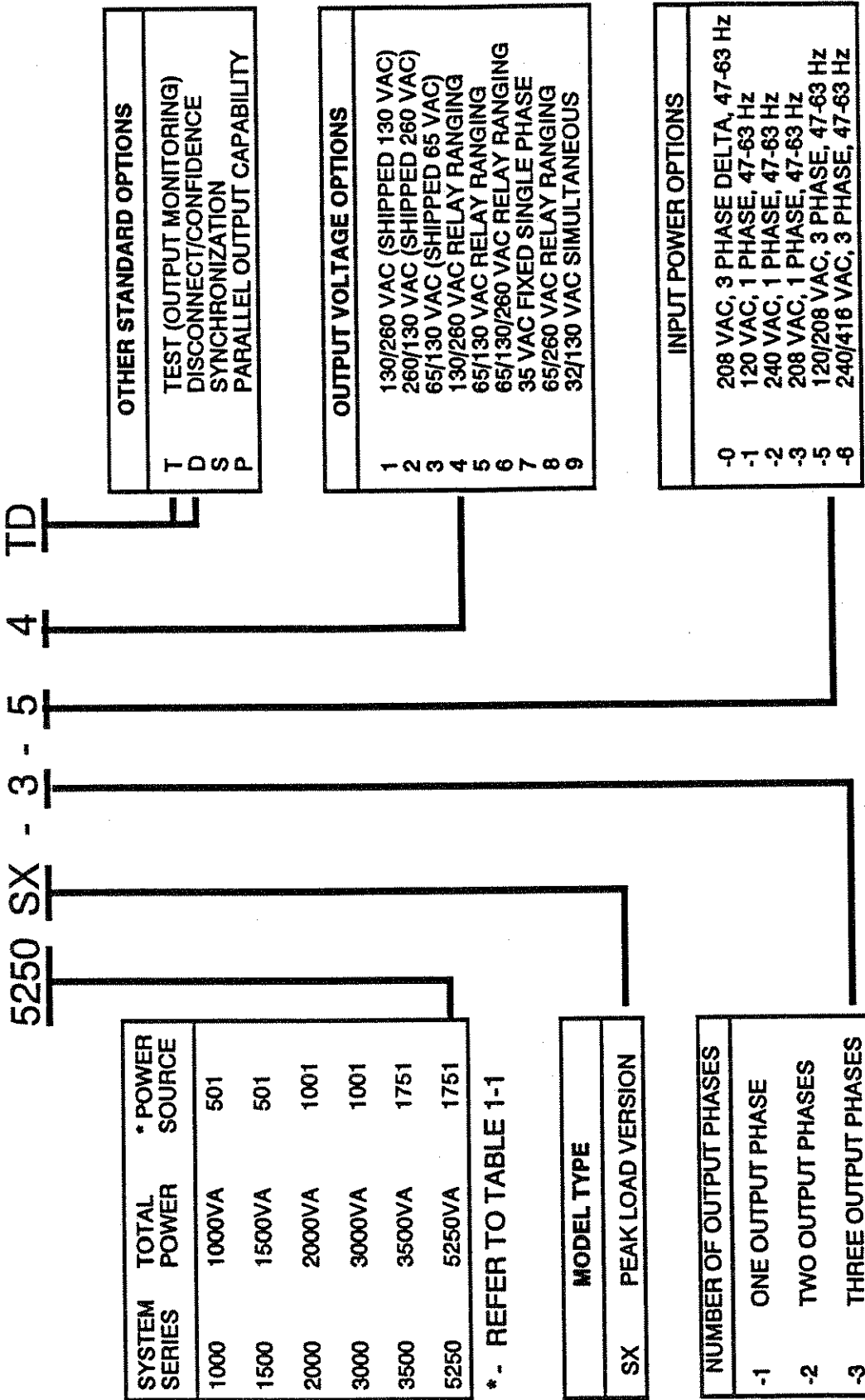

Figure 1-3. SX System Multi-Phase Model Identification Information

Table 1-1. Multi-Phase System Configurations

System Series	Number of Phases	Configuration
1000	2	Two Model 501SXs in 2Ø at 90°; one 400SR; one signal cable (refer to Section II for further information).
1500	3	Three Model 501SXs in a 4-wire Y; two 400SRs; one signal cable (refer to Section II for further information).
2000	2	Two Model 1001SXs in 2Ø at 90°; one 400SR; one signal cable (refer to Section II for further information).
3000	3	Three Model 1001SXs in a 4-wire Y; two 400SRs; one signal cable (refer to Section II for further information).
3500	2	Two Model 1751SXs in 2Ø at 90°; one 400SR; one signal cable (refer to Section II for further information).
5250	3	Three Model 1751SXs in a 4-wire Y; two 400SRs; one signal cable (refer to Section II for further information).

1.4 SPECIFICATIONS

Peak Output Power: 3675 VA.

The performance specifications listed in paragraphs 1.4.1 through 1.4.3 provide baseline information for the particular model.

Effective DC Power Output: Refer to Table 1-2.

NOTE

1.4.1 Model 501SX Specifications

1.4.1.1 Output Characteristics

Continuous Output Power: A minimum of 500 VA from a 55-65 VAC, 110-130 VAC, or 220-260 VAC input, with a power factor (PF) from unity to ±0.7 PF, over ±10% of the input line (refer to Figure 1-1 for the power derating curve).

Table 1-2 indicates the power output for a Model 501SX with a full wave rectifier and capacitive input. Rectifier loss and the power loss in the series resistance must be subtracted from the indicated output power.

Table 1-2. Model 501SX Effective DC Power Output

Approximate Firing Angle	Load Current Crest Factor	DC Output
60°	2.5	500 Watts
40°	3.0	350 Watts
30°	3.5	225 Watts

Output Voltage Range, Standard Output Transformer:

0-65 VRMS; 0-130 VRMS; or 0-260 VRMS. The rear panel and internal jumpers provide either 0-65/130 VAC or 0-130/260 VAC voltage ranges.

Output Voltage Range, Optional Output Transformer:

0-32 VAC or 0-130 VAC simultaneous.

Voltage Monitoring: Available via a meter on the front panel of the unit.

Voltage Control: Adjustable, zero to full scale via a locking front panel potentiometer or optional GPIB remote.

Output Current: Refer to Table 1-3.

Table 1-3. Model 501SX Output Current

Output Voltage	Maximum RMS Output Current Per Phase	Peak Repetitive Output Current
0-65 VAC	11.5 Amps	-----
0-130 VAC (Nominal Line Input)	-----	20 Amps
0-130 VAC (±10% Input Line)	5.8 Amps	18 Amps
0-260 VAC	2.9 Amps	9 Amps

Frequency Range: 45 Hz to 1 kHz at full rated power.

Total Harmonic Distortion (THD):

- $\pm 1\%$ maximum from 45 Hz to 75 Hz with a pulsed load whose firing angle is 30° or greater.
- $\pm 4\%$ maximum from 75 Hz to 450 Hz with a pulsed load whose firing angle is 60° or greater.
- $\pm 0.5\%$ maximum from 45 Hz to 1 kHz with a linear load.

Load Regulation:

- $\pm 1\%$ over the range from 45 Hz to 75 Hz with a pulsed load whose firing angle is 30° or greater.
- $\pm 1\%$ over the range from 75 Hz to 450 Hz with a pulsed load whose firing angle is 60° or greater.
- $\pm 1\%$ over the range from 45 Hz to 1 kHz with a linear load.

Line Regulation: $\pm 0.25\%$ at the rated load for a $\pm 10\%$ input range at the full scale output voltage.

Response Time: $< 50 \mu\text{seconds}$.

AC Noise Level: 70 dB below full output voltage with a grounded input.

Gain Stability: $\pm 0.25\%$ for 24 hours at constant line, load and temperature after warm-up.

Overload and Short Circuit Protection:

Automatic electronic current limiting senses both excessive load current and/or low power factor. Automatic instantaneous reset occurs when the overload is removed unless the front panel circuit breaker is activated.

Thermal Protection: An automatically resetting thermal sensor removes the output voltage to prevent damage due to excessive overload or heatsink temperature.

1.4.1.2 Input Characteristics

Line Voltage: User selectable 115 VAC or 230 VAC, $\pm 10\%$, single phase.

Line Frequency: 47-63 Hz continuous (380-420 Hz optional); 45-70 Hz for short term transients.

Efficiency: Up to 55%.

Line Power: 1400 watts, maximum.

Line Volt-Amperes: 2100 VA, maximum.

Line Input: A three wire input via the terminal block on the rear of the chassis. The 115 VAC or 230 VAC selection is made via an external switch.

1.4.1.3 ATE Features

Range Change Relays: The manual oscillator (or PIP) allows the internal range change relays to switch between 130 VAC and 260 VAC via either front panel control or under special GPIB control. Other voltage ranges are available as special options.

Output Relay: An optional internal output relay can connect the load to the output of the power source under GPIB control.

Remote Sense: Available with a PIP and other selected oscillators.

Current Limit Feedback: An optional internal current transformer will provide current limit feedback to the PIP oscillator.

PIP Sync In/Out: The PIP can be optionally synchronized by an external source. This allows a PIP to synchronize to another PIP.

Built-In-Test-Equipment (BITE): Optional with the use of the Elgar PIP 704, PIP 9012 or PIP 9023 programmable oscillators. Depending on the PIP, the system measures and reports output RMS voltage and load current, frequency, output phase angle, and true RMS power in watts.

1.4.1.4 General

Operating Temperature Range: 0°C to 55°C (32°F to 131°F).

Operating Humidity Range: Up to 95%, non condensing.

Cabinet Mounting: Standard 19" (483 mm) RETMA rack mounting using 20" (508 mm) rack slides.

Dimensions: 5.25" (133 mm) high X 19" (483 mm) wide X 21" (533 mm) deep.

Net Weight: 80 pounds (36 kg).

Shipping Weight: 88 pounds (40 kg).

Front Panel Finish: Light gray, color #26408, per FED-STD-595A with black silk screening, color #27038.

Cooling: Single 4.25" (108 mm) fan mounted inside the unit with side air intake and rear air exhaust.

Front Panel Meter: A 0 to 300 VAC voltmeter provides $\pm 3\%$ of full scale accuracy over the 45 Hz to 1 kHz frequency range.

J1 Interface Connector: 15 pin configuration for added flexibility.

1.4.2 Model 1001SX Specifications

Effective DC Power Output: Refer to Table 1-4.

1.4.2.1 Output Characteristics

Continuous Output Power: A minimum of 1000 VA from a 55-65 VAC, 110-130 VAC, or 220-260 VAC input, with a power factor (PF) from unity to ± 0.7 PF, over $\pm 10\%$ of the input line (refer to Figure 1-1 for the power derating curve).

Peak Output Power: 7350 VA.

NOTE

Table 1-4 indicates the power output for a Model 1001SX with a full wave rectifier and capacitive input. Rectifier loss and the power loss in the series resistance must be subtracted from the indicated output power.

Table 1-4. Model 1001SX Effective DC Power Output

Approximate Firing Angle	Load Current Crest Factor	DC Output
60°	2.5	1000 Watts
40°	3.0	700 Watts
30°	3.5	450 Watts

Output Voltage Range, Standard Output Transformer:

0-65 VRMS; 0-130 VRMS; or 0-260 VRMS. The rear panel and internal jumpers provide either 0-65/130 VAC or 0-130/260 VAC voltage ranges.

Output Voltage Range, Optional Output Transformer:

0-32 VAC or 0-130 VAC simultaneous.

Voltage Monitoring: Available via a meter on the front panel of the unit.

Voltage Control: Adjustable, zero to full scale via a locking front panel potentiometer or optional GPIB remote.

Output Current: Refer to Table 1-5.

Table 1-5. Model 1001SX Output Current

Output Voltage	Maximum RMS Output Current Per Phase	Peak Repetitive Output Current
0-65 VAC	23.1 Amps	-----
0-130 VAC (Nominal Line Input)	-----	40 Amps
0-130 VAC (± 10% Input Line)	11.5 Amps	36 Amps
0-260 VAC	5.8 Amps	18 Amps

Frequency Range: 45 Hz to 1 kHz at full rated power.

Total Harmonic Distortion (THD):

- ±1% maximum from 45 Hz to 75 Hz with a pulsed load whose firing angle is 30° or greater.
- ±4% maximum from 75 Hz to 450 Hz with a pulsed load whose firing angle is 60° or greater.
- ±0.5% maximum from 45 Hz to 1 kHz with a linear load.

Load Regulation:

- ±1% over the range from 45 Hz to 75 Hz with a pulsed load whose firing angle is 30° or greater.
- ±1% over the range from 75 Hz to 450 Hz with a pulsed load whose firing angle is 60° or greater.
- ±1% over the range from 45 Hz to 1 kHz with a linear load.

Line Regulation: ±0.25% at the rated load for a ±10% input range at the full scale output voltage.

Response Time: < 50 μseconds.

AC Noise Level: 70 dB below full output voltage with a grounded input.

Gain Stability: ±0.25% for 24 hours at constant line, load and temperature after warm-up.

Overload and Short Circuit Protection: Automatic electronic current limiting senses both excessive load current and/or low power factor. Automatic instantaneous reset occurs when the overload is removed unless the front panel circuit breaker is activated.

Thermal Protection: An automatically resetting thermal sensor removes the output voltage to prevent damage due to excessive overload or heatsink temperature.

1.4.2.2 Input Characteristics

Line Voltage: User selectable 115 VAC, 208 VAC, or 230 VAC, $\pm 10\%$, single phase.

Line Frequency: 47-63 Hz continuous (380-420 Hz optional); 45-70 Hz for short term transients.

Efficiency: Up to 55%.

Line Power: 2800 watts, maximum.

Line Volt-Amperes: 4200 VA, maximum.

Line Input: A three wire input via the terminal block on the rear of the chassis. The 115 VAC or 230 VAC selection is made via an external switch; the 208 VAC selection is made via an internal connection.

1.4.2.3 ATE Features

Range Change Relays: The manual oscillator (or PIP) allows the internal range change relays to switch between 130 VAC and 260 VAC via either front panel control or under special GPIB control. Other voltage ranges are available as special options.

Output Relay: An optional internal output relay can connect the load to the output of the power source under GPIB control.

Remote Sense: Available with a PIP and other selected oscillators.

Current Limit Feedback: An optional internal current transformer will provide current limit feedback to the PIP oscillator.

PIP Sync In/Out: The PIP can be optionally synchronized by an external source. This allows a PIP to synchronize to another PIP.

Built-In-Test-Equipment (BITE): Optional with the use of the Elgar PIP 704, PIP 9012 or PIP 9023 programmable oscillators. Depending on the PIP, the system measures and reports output RMS voltage and load current, frequency, output phase angle, and true RMS power in watts.

1.4.2.4 General

Operating Temperature Range: 0°C to 55°C (32°F to 131°F).

Operating Humidity Range: Up to 95%, non condensing.

Cabinet Mounting: Standard 19" RETMA rack mounting using 20" rack slides.

Dimensions: 7" (178 mm) high X 19" (483 mm) wide X 21" (533 mm) deep from the front panel mounting surface.

Net Weight: 130 pounds (59 kg).

Shipping Weight: 140 pounds (64 kg).

Front Panel Finish: Light gray, color #26408, per FED-STD-595A with black silk screening, color #27038.

Cooling: Single 5.75" (146 mm) fan mounted inside the unit with side air intake and rear air exhaust.

Front Panel Meter: A 0 to 300 VAC voltmeter provides $\pm 3\%$ of full scale accuracy over the 45 Hz to 1 kHz frequency range.

J1 Interface Connector: 15 pin configuration for added flexibility.

Effective DC Power Output: Refer to Table 1-6.

1.4.3 Model 1751SX Specifications

NOTE

1.4.3.1 Output Characteristics

Continuous Output Power: A minimum of 1750 VA from a 55-65 VAC, 110-130 VAC, or 220-260 VAC input, with a power factor (PF) from unity to ± 0.7 PF, over $\pm 10\%$ of the input line (refer to Figure 1-1 for the power derating curve).

Table 1-6 indicates the power output for a Model 1751SX with a full wave rectifier and capacitive input. Rectifier loss and the power loss in the series resistance must be subtracted from the indicated output power.

Peak Output Power: 12,865 VA.

Table 1-6. Model 1751SX Effective DC Power Output

Approximate Firing Angle	Load Current Crest Factor	DC Output
60°	2.5	1750 Watts
40°	3.0	1200 Watts
30°	3.5	750 Watts

Output Voltage Range, Standard Output Transformer:

0-65 VRMS; 0-130 VRMS; or 0-260 VRMS. The rear panel and internal jumpers provide either 0-65/130 VAC or 0-130/260 VAC voltage ranges.

Voltage Monitoring: Available via a meter on the front panel of the unit.

Voltage Control: Adjustable, zero to full scale via a locking front panel potentiometer or optional GPIB remote.

Output Voltage Range, Optional Output Transformer:

0-32 VAC or 0-130 VAC simultaneous.

Output Current: Refer to Table 1-7.

Table 1-7. Model 1751SX Output Current

Output Voltage	Maximum RMS Output Current Per Phase	Peak Repetitive Output Current
0-65 VAC	40.4 Amps	-----
0-130 VAC (Nominal Line Input)	-----	70 Amps
0-130 VAC (± 10% Input Line)	20.2 Amps	60 Amps
0-260 VAC	10.1 Amps	30 Amps

Frequency Range: 45 Hz to 1 kHz at full rated power.

Line Regulation: ±0.25% at the rated load for a ±10% input range at the full scale output voltage.

Total Harmonic Distortion (THD):

Response Time: < 50 μseconds.

- ±1% maximum from 45 Hz to 75 Hz with a pulsed load whose firing angle is 30° or greater.
- ±6% maximum from 75 Hz to 450 Hz with a pulsed load whose firing angle is 60° or greater.
- ±0.5% maximum from 45 Hz to 1 kHz with a linear load.

AC Noise Level: 70 dB below full output voltage with a grounded input.

Gain Stability: ±0.25% for 24 hours at constant line, load and temperature after warm-up.

Load Regulation:

Overload and Short Circuit Protection: Automatic electronic current limiting senses both excessive load current and/or low power factor. Automatic instantaneous reset occurs when the overload is removed unless the front panel circuit breaker is activated.

- ±1% over the range from 45 Hz to 75 Hz with a pulsed load whose firing angle is 30° or greater.
- ±1% over the range from 75 Hz to 450 Hz with a pulsed load whose firing angle is 60° or greater.
- ±1% over the range from 45 Hz to 1 kHz with a linear load.

Thermal Protection: An automatically resetting thermal sensor removes the output voltage to prevent damage due to excessive overload or heatsink temperature.

1.4.3.2 Input Characteristics

Line Voltage: User selectable 115 VAC, 208 VAC, or 230 VAC, $\pm 10\%$, single phase.

Line Frequency: 47-63 Hz continuous (380-420 Hz optional); 45-70 Hz for short term transients.

Efficiency: Up to 55%.

Line Power: 5000 watts, maximum.

Line Volt-Amperes: 7500 VA, maximum.

Line Input: A three wire input via the terminal block on the rear of the chassis. The 115 VAC or 230 VAC selection is made via an external switch; the 208 VAC selection is made via an internal connection.

1.4.3.3 ATE Features

Range Change Relays: The manual oscillator (or PIP) allows the internal range change relays to switch between 130 VAC and 260 VAC via either front panel control or under special GPIB control. Other voltage ranges are available as special options.

Output Relay: An optional internal output relay can connect the load to the output of the power source under GPIB control.

Remote Sense: Available with a PIP and other selected oscillators.

Current Limit Feedback: An optional internal current transformer will provide current limit feedback to the PIP oscillator.

PIP Sync In/Out: The PIP can be optionally synchronized by an external source. This allows a PIP to synchronize to another PIP.

Built-In-Test-Equipment (BITE): Optional with the use of the Elgar PIP 704, PIP 9012 or PIP 9023 programmable oscillators. Depending on the PIP, the system measures and reports output RMS voltage and load current, frequency, output phase angle, and true RMS power in watts.

1.4.3.4 General

Operating Temperature Range: 0°C to 55°C (32°F to 131°F).

Operating Humidity Range: Up to 95%, non condensing.

Cabinet Mounting: Standard 19" RETMA rack mounting using 20" rack slides.

Dimensions: 12.25" (311 mm) high X 19" (483 mm) wide X 21" (533 mm) deep from the front panel mounting surface.

Net Weight: 195 pounds (89 kg).

Shipping Weight: 205 pounds (93 kg).

Front Panel Finish: Light gray, color #26408, per FED-STD-595A with black silk screening, color #27038.

Cooling: Two 5.75" (146 mm) fans mounted inside the unit with side air intake and rear air exhaust.

Front Panel Meter: A 0 to 300 VAC voltmeter provides $\pm 3\%$ of full scale accuracy over the 45 Hz to 1 kHz frequency range.

J1 Interface Connector: 15 pin configuration for added flexibility.

**SPECIFICATIONS ARE SUBJECT TO CHANGE
WITHOUT NOTICE**

SECTION II

INSTALLATION

2.1 INTRODUCTION

The Model 501SX/1001SX/1751SX has been configured, calibrated and tested prior to shipment. Therefore, the instrument is ready for immediate use upon receipt. The following initial physical inspections should be conducted to ensure that no damage has been sustained by the instrument during shipment.

WARNING

Hazardous voltages are present when operating this equipment. Read the "SAFETY" notices on page ii before performing installation, operation, or maintenance.

The user should become familiar with the particular model and configuration of the SX Series AC Power Source (refer to Section I). The following topics should be thoroughly understood before making connections or applying AC input power. To simplify this process, the topics are arranged as follows:

- 2.2 Unpacking
- 2.3 Pre-Installation Inspection
- 2.4 Options
- 2.5 Model 501SX Installation
- 2.6 Model 1001SX Installation
- 2.7 Model 1751SX Installation
- 2.8 System Interconnection

Appendix A provides recommended guidelines for wire gauge selection. Appendix B contains the Configuration and Functional Verification Checksheet (refer to and copy this appendix as required). This checksheet simplifies the configuration and functional

verification process. The checksheet also serves as an ideal reference during application and as a permanent maintenance record.

CAUTION

Do not apply AC input voltage to this instrument nor connect any load(s) without first verifying correct input line voltage and output wiring configuration. This instrument and any external loads or cables may be damaged by improper voltage settings, cable mis-wiring, etc.

2.2 UNPACKING

The instrument has been packed in accordance with industrial standards for safe shipment. Upon receipt of the unit, unpack and inspect the unit as follows:

1. Inspect the shipping container prior to accepting the container from the carrier. If damage to the container is evident, a description of the damage shall be noted on the carrier's receipt, then signed by the carrier's agent.
2. If damage is not apparent until the contents are unpacked, a claim for concealed damage shall be placed with the carrier. The shipping container(s) and filler material shall be saved for subsequent inspection.
3. Forward a report of any damage to the Elgar Service Department. Elgar will provide instructions for repair/replacement of the instrument.

4. If possible, save the container and packing material for subsequent return of the instrument to the factory. Repacking is straightforward and is essentially the reverse of unpacking. If the instrument needs to be shipped and proper packing material is not available, contact Elgar to provide containers and shipping instructions.

2.3 PRE-INSTALLATION INSPECTION

Perform the following:

1. Inspect the power source for shipping damage such as dents, scratches, distortion, and damaged connectors. There are no mercury relays or other internal components sensitive to chassis tilting for inspection purposes.
2. Check the front panel AMPLITUDE control and power switch for ease of operation.
3. Remove the instrument covers and verify that the circuit boards are securely seated in their respective receptacles. Ensure that individual components are not damaged.
4. Check the rear of the chassis for damage to the connectors.
5. Check the harness and leads for broken insulation, cracks, or broken wiring.

2.4 OPTIONS

The standard options available for the power source include several input and output voltages, automatic range changing, sync access, output monitoring, and different oscillators.

2.4.1 Input Voltages

The input voltages are single phase 115 VAC, single phase 230 VAC, and single phase 208 VAC (the Model 501SX does not have a 208 VAC capability). These voltages are user selectable at terminal block TB1 (located on the rear panel), and at TB3 (within the power source). Figure 2-1 defines the required jumper connections.

2.4.2 Output Voltages

The output voltages available are 0-65 VAC, 0-130 VAC, and 0-260 VAC. These voltages are selectable at terminal blocks TB2, located on the rear panel, and TB3, located within the instrument. Figure 2-2 defines the required jumper connections.

NOTE

Systems using two or more units require interconnect wiring as explained in paragraph 2.8.

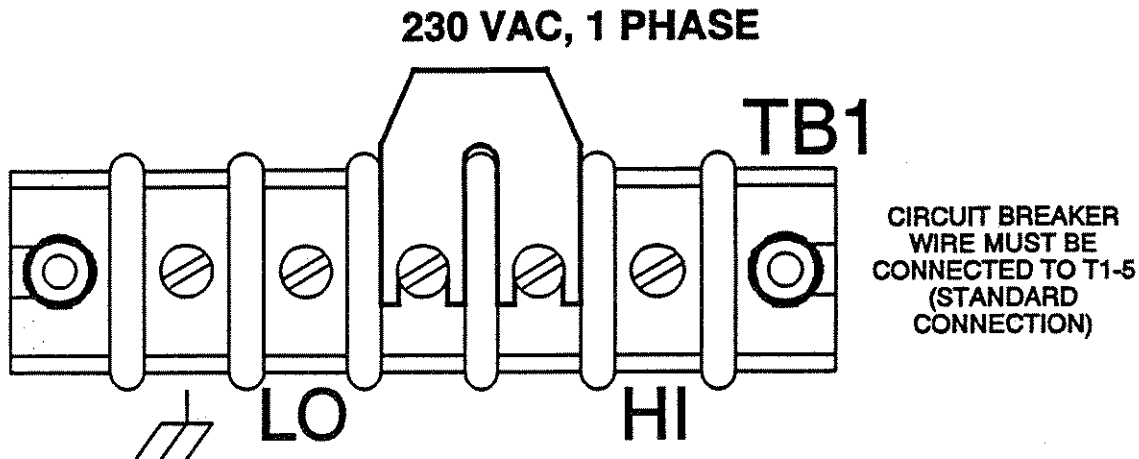
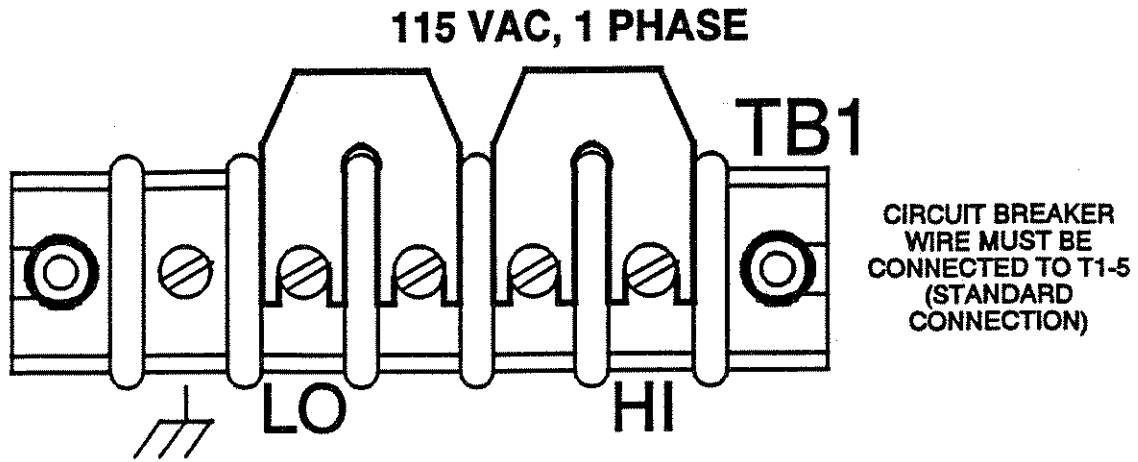

208 VAC, 1 PHASE

IF THE AC POWER SOURCE IS SHIPPED FROM THE FACTORY AS A 208 VAC INPUT, THE SERIAL NUMBER TAG WILL SO NOTE.

TO CONNECT FOR 208 VAC, CONNECT AS FOR THE 230 VAC ABOVE PLUS MOVE THE WIRE FROM T1-5 TO T1-4 (TO ACCESS T1, REMOVE THE BOTTOM COVER). PLACE AN INSULATING BOOT ON T1-5 AND SLEEVING AT T1-4.

Figure 2-1. Input Voltage Options

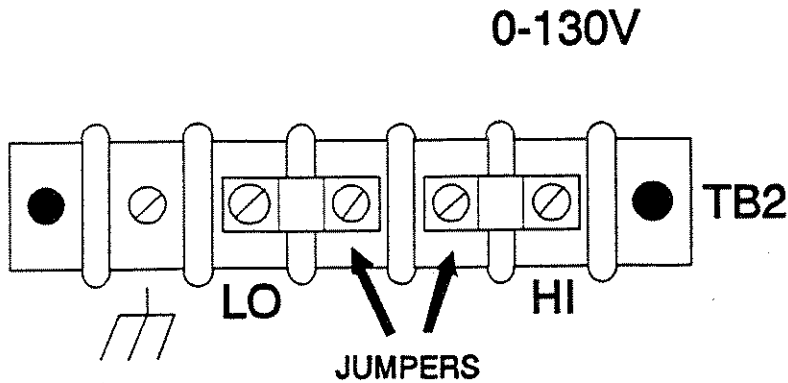

FOR 0-130V, TB3 MUST HAVE TWO JUMPERS ONLY; ONE FROM TB3-2 TO TB3-3, THE OTHER FROM TB3-6 TO TB3-7.

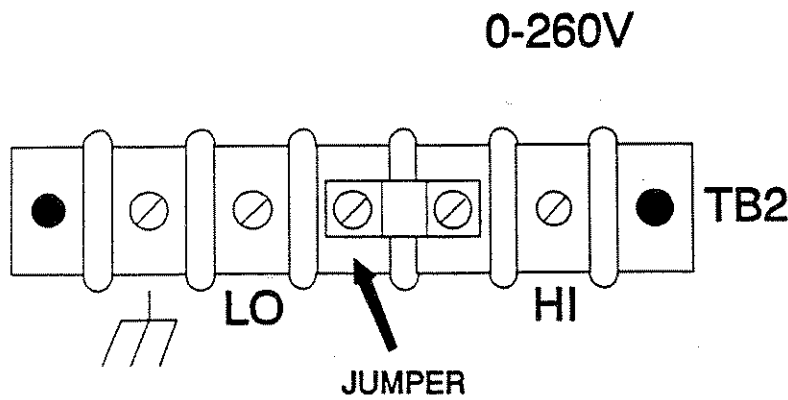

FOR 0-260V, TB3 MUST HAVE TWO JUMPERS ONLY; ONE FROM TB3-2 TO TB3-3, THE OTHER FROM TB3-6 TO TB3-7.

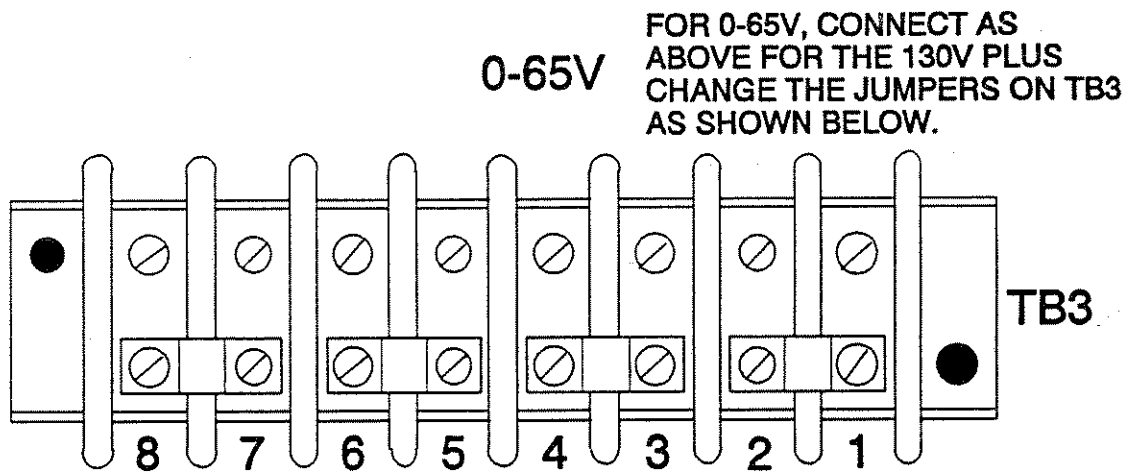

FOR 0-65V, CONNECT AS ABOVE FOR THE 130V PLUS CHANGE THE JUMPERS ON TB3 AS SHOWN BELOW.

(TB3 IS LOCATED ON THE INSIDE OF THE REAR PANEL)

Figure 2-2. Output Voltage Options

2.4.3 Oscillators

Power Amplifiers require a plug-in oscillator or an externally applied sine wave signal of 0-3 VRMS to be a complete power source/ frequency converter. A plug-in oscillator module establishes the output frequency. A variety of fixed and variable frequency oscillator modules are available covering the range of 45 Hz to 10kHz at accuracies of 0.25% to 0.001%. Specialized oscillators are available such as the Plug-In Programmable (PIP) Series, which is MATE compatible, and the TG-704A transient generator. Refer to the appropriate PIP manual for programming information.

2.4.4 Other Options

The SX motherboard has been designed to provide a means to implement special options such as automatic output voltage range changing, output current limit programming, synchronization (sync in/sync out), and output voltage/current/power monitoring. These "specials" are GPIB compatible.

2.4.4.1 "-T" Option

With the addition of a current sense transformer to the power source, true RMS measurement and transmission of voltage, current, frequency, and power information is accomplished via the GPIB interface. The output voltage range will be set at 130V or 260V (refer to the partial schematics provided in Figures 2-3 through 2-7).

2.4.4.2 "-D" Option

The confidence test allows the unit to verify proper output servo sensing even with a load connected to the output. The servo loop is checked locally at the power source oscillator. This is accomplished by disconnecting the external load and servo feedback path. Relay K5 switches between the normal and confidence test modes (refer to the Model 501SX/1001SX/1751SX Service Manual, Schematic No. 5070001, for further information). Refer to the partial schematic in Figure 2-7.

2.4.4.3 "-S" Option

Rear panel BNC connectors are provided for oscillator sync input/output connections (refer to the Model 501SX/1001SX/1751SX Service Manual, Schematic No. 6070005, for further information).

2.4.4.4 Range Change Option

This option is a standard feature of the SX Series. Automatic range change between predetermined output voltages (refer to Table 2-1) is enabled via a GPIB interface from the PIP front panel local controls. Refer to the partial schematics illustrated in Figures 2-4 through 2-7.

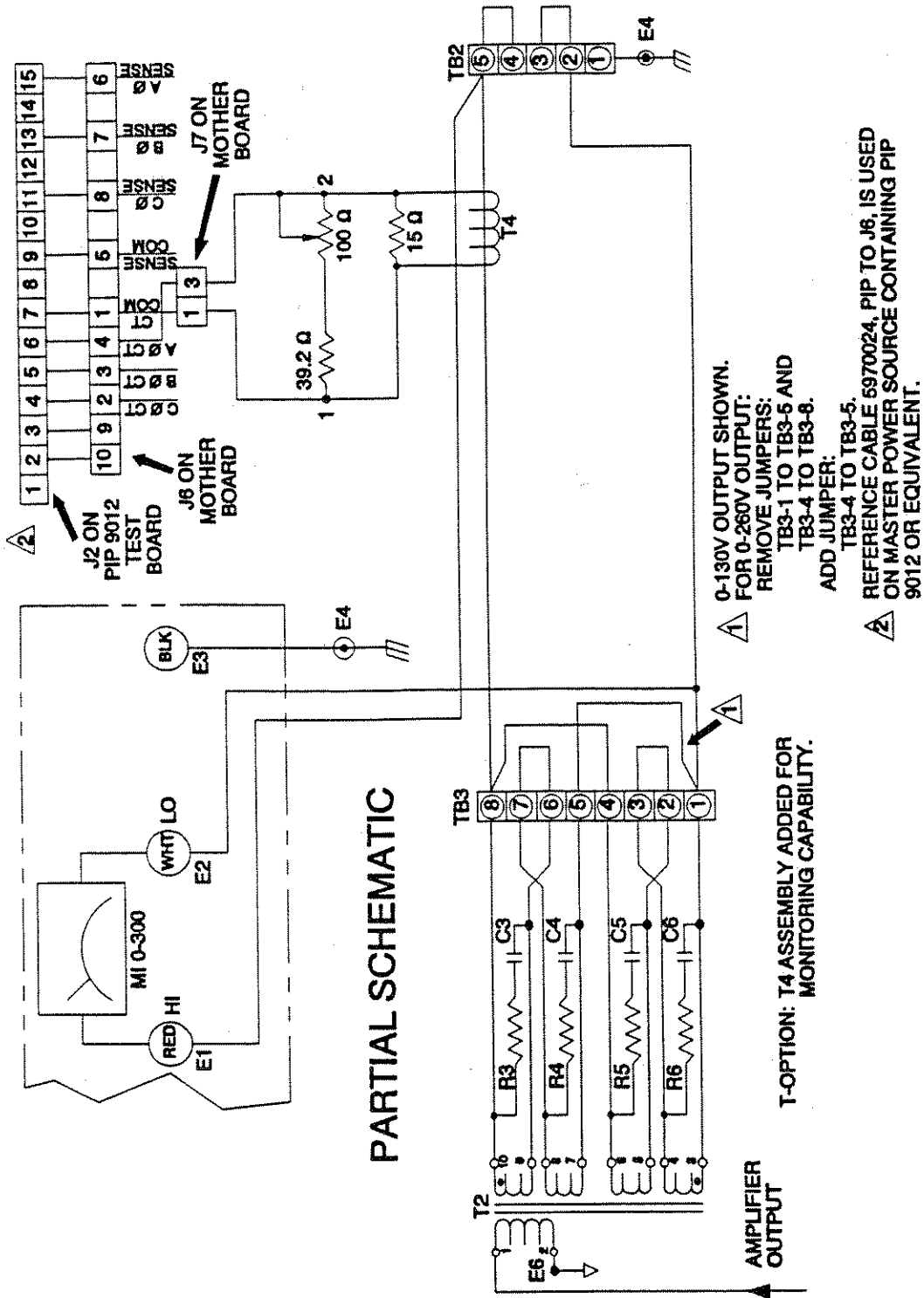

Figure 2-3. Output Monitoring Option

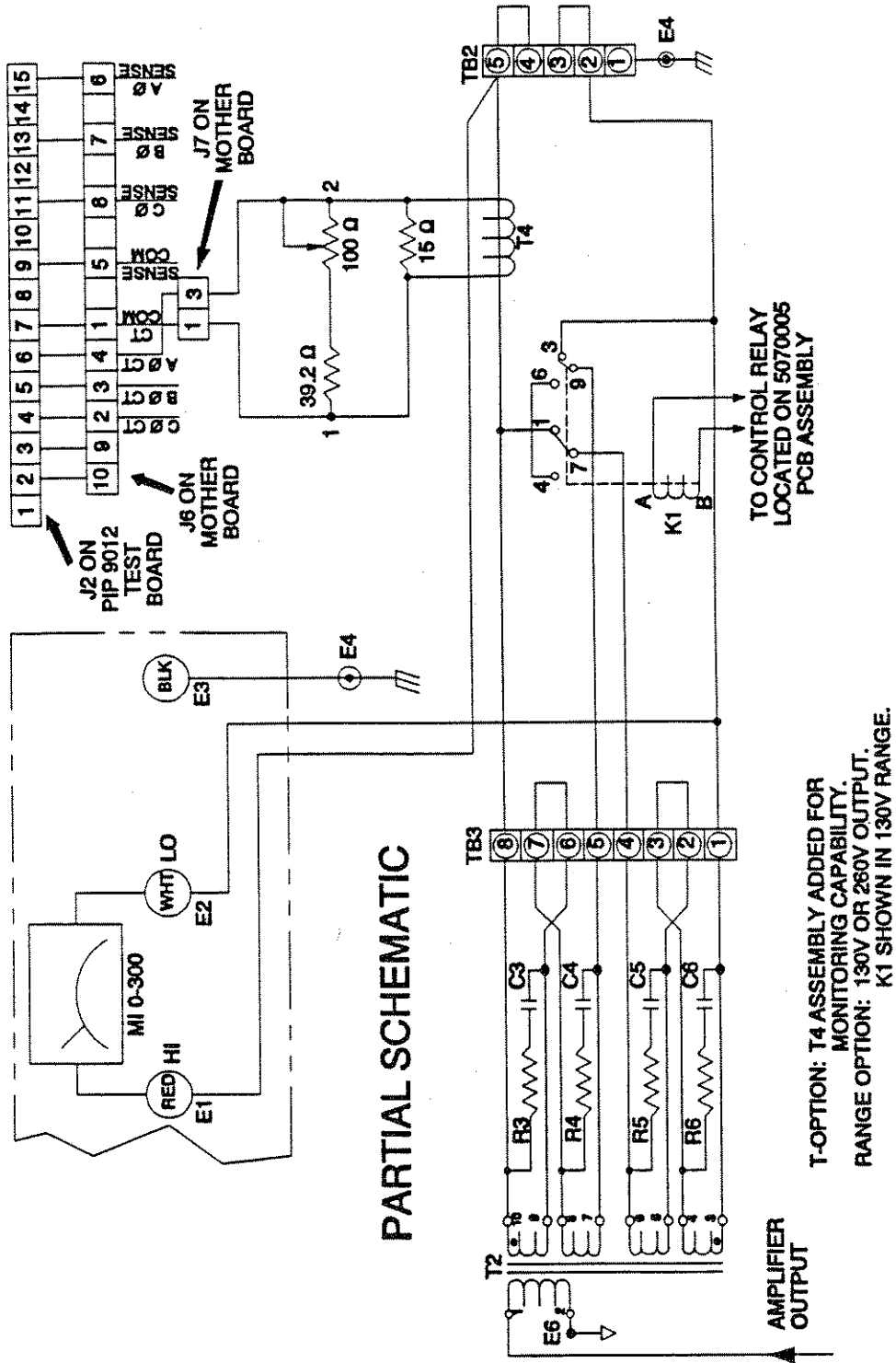

Figure 2-4. Output Monitoring and 130V/260V Ranging Options

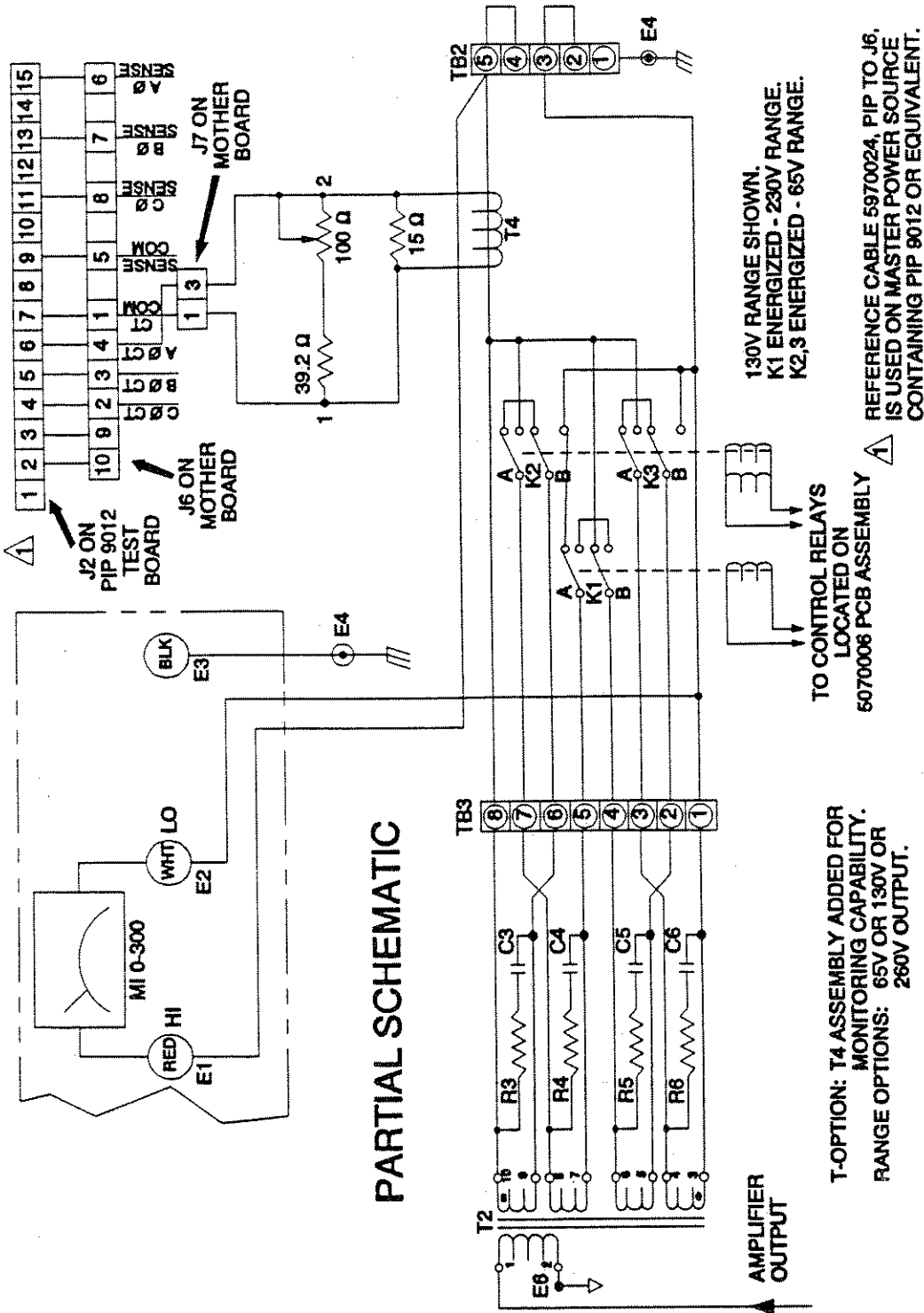

Figure 2-5. Output Monitoring and 65V/130V/260V Ranging Options

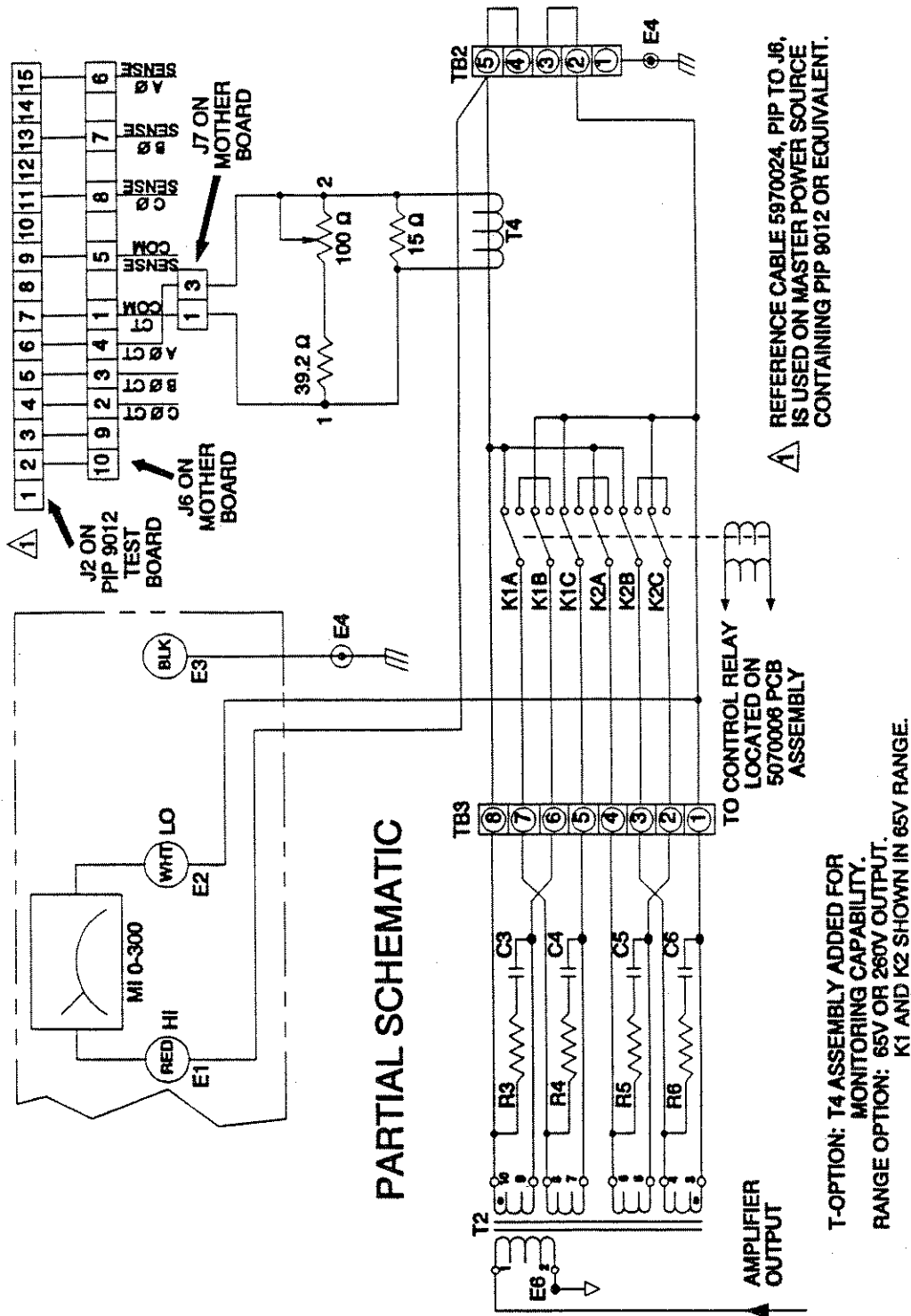

Figure 2-6. Output Monitoring and 65V/260V Ranging Options

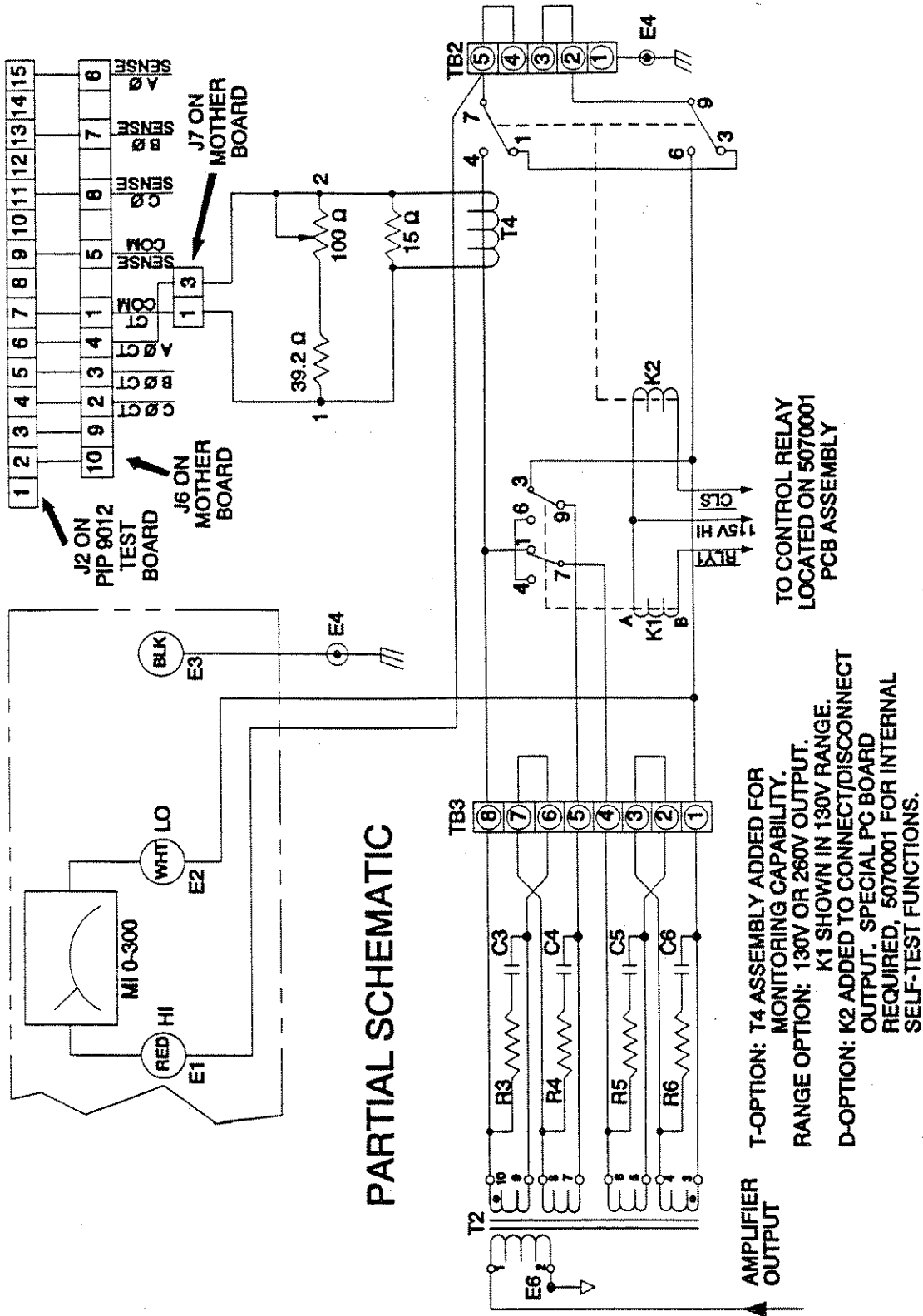

Figure 2-7. Output Monitoring, 130V/260V Ranging, and Output Connect/Disconnect Options

Table 2-1. Model 501SX/1001SX/1751SX Options

NOTE

The three columns below correspond to the three digits after the dash of the serial number on the instrument tag.

Input Voltage		Output Voltage		Standard Options	
"-"	Definition	"-"	Definition	"-"	Definition
-1	115 VAC, 1Ø, 47-63 Hz	-1	130/260 VAC*	-T	Test (Output monitoring and current limit programming via GPIB).****
-2	230 VAC, 1Ø, 47-63 Hz	-2	260/130 VAC**	-D	Output disconnect relay via GPIB (Confidence Test)
-3	208 VAC, 1Ø, 47-63 Hz	-3	65/130 VAC*	-S	Synchronization (Sync In/Sync Out)
-4	115 VAC, 1Ø, 380-420 Hz	-4	130/260 VAC***	-P	Parallel Output
		-5	65/130 VAC***		
		-6	65/130/260 VAC***		
		-7	Not Applicable to SX Series		
		-8	65/260 VAC***		
		-9	32/130 VAC Simultaneous		

- * Standard manual range change on rear output barrier strip.
- ** Standard manual range change on rear output barrier strip, but set up for 0-260VAC at factory.
- *** Automatic range change via GPIB (PIP).
- **** T Option: Requires that the output voltage range be set at 130V or 260V. Internal connections are required to change the range. Output voltage options -4, -5, -6, and -8 can provide relay range change capability.

An 0 to 300 VAC output voltmeter is standard on all SX units.

EXAMPLE: Complete Model designation **1001SX-14T** would indicate that the unit is configured for 115 VAC input, 130/260 VAC output ranging, and has full T-option capabilities.

2.5 MODEL 501SX INSTALLATION

The Model 501SX AC Power Source is designed for installation in a standard 19" (483 mm) instrument rack (refer to Figures 2-8 through 2-10 for outline drawings, mounting dimensions and the location of controls and connectors).

The Model 501SX must be installed such that the flow of cooling air into the side panel grills and out the rear panel is not obstructed. For slide out capability, the unit is equipped with threaded inserts located on each side for mounting slides.

2.5.1 Input Power Requirements

The standard Model 501SX operates from 115 VAC or 230 VAC single phase input power at 47 Hz to 63 Hz. The input power terminal block is located on the rear panel (refer to Figure 2-10 for location). Figure 2-1 provides input voltage connection options.

2.5.2 Output Power Connections

Output power is provided at a terminal block located on the rear panel of the unit (refer to Figure 2-10 for location). A listing of available output power can be found in Table 2-1. Figure 2-2 provides output voltage connection options.

2.5.3 Sync Out BNC Connectors

The Model 501SX can be optionally equipped with BNC-type 'Sync' connectors located on the rear panel of the unit (refer to Figure 2-10 for location).

2.5.4 Installing The Model 501SX

To install the Model 501SX AC Power Source, perform the following:

1. Before installing the power source, verify that the input and output voltage ranges are compatible with the available utility power and the output voltage application. Refer to Figures 2-9 and 2-10, Table 2-1, and the unit serial number tag for model number information.
2. The power source is designed for installation in a standard 19" (483 mm) RETMA electronic equipment rack. Install the power source in the appropriate rack such that the flow of cooling air into and out of the unit is unobstructed. Allow 6" (152 mm) clearance at the rear of the unit.
3. Position the POWER switch-circuit breaker to OFF (down).
4. Insert the appropriate Elgar oscillator, which provides control over output voltages and frequencies, into the front panel in accordance with the appropriate oscillator Operating Manual.
5. Connect the output load to the rear panel output terminal block (TB2). For initial installation, a dummy load should be used until the unit is completely checked out and verified as operational.
6. Connect the input power to the rear panel input power terminal block (TB1) (refer to Figure 2-1 for input voltage connection options).

2.5.5 Model 501SX Preliminary Functional Checkout

To check the Model 501SX AC Power Source after initial installation, perform the following:

1. Position the POWER switch-circuit breaker to ON (up). Observe that the POWER On indicator is illuminated (green).
2. Ensure that the fan is exhausting air through the rear panel grill.
3. Set the Elgar oscillator to the desired amplitude and frequency (refer to the oscillator's Operating Manual for specific instructions).
4. Position the POWER switch-circuit breaker to OFF (down). Observe that the Power On indicator is no longer illuminated and that the fan turns off.

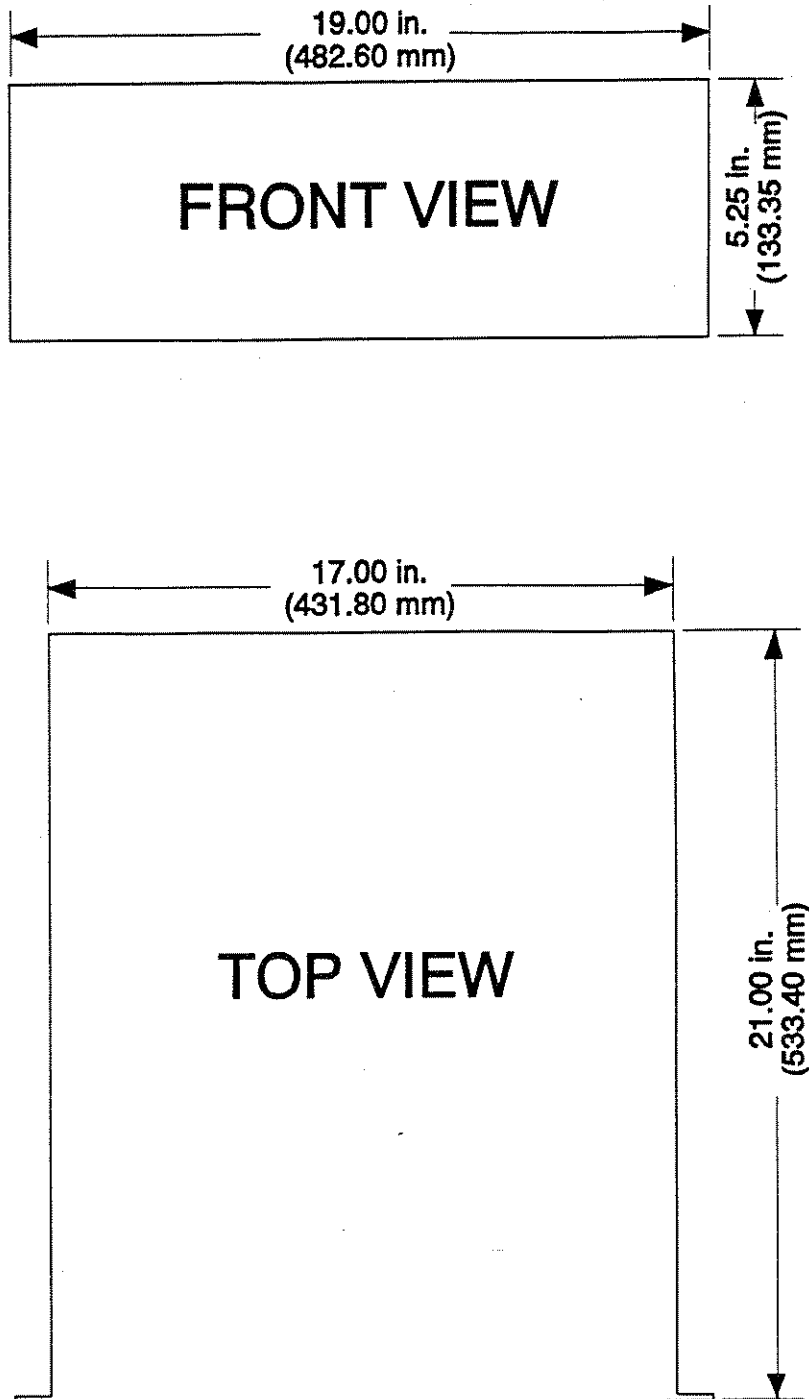

Figure 2-8. Model 501SX Installation Dimensions

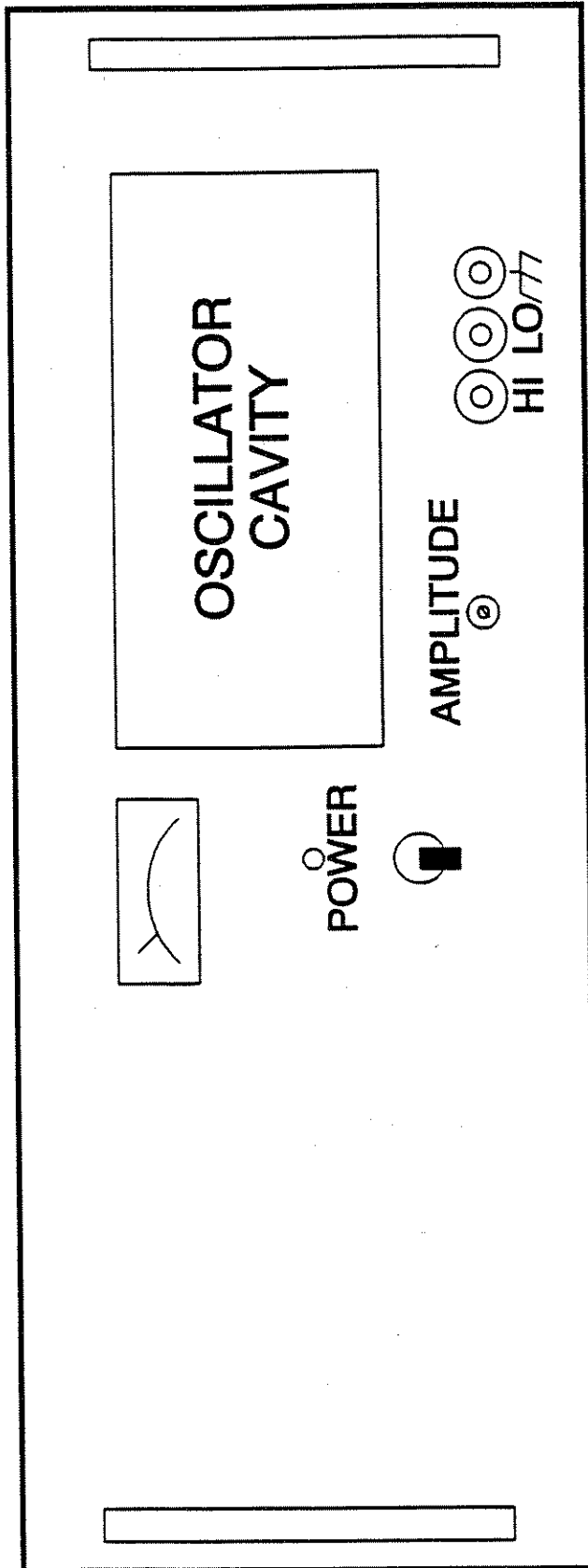

Figure 2-9. Model 501SX (Front View)

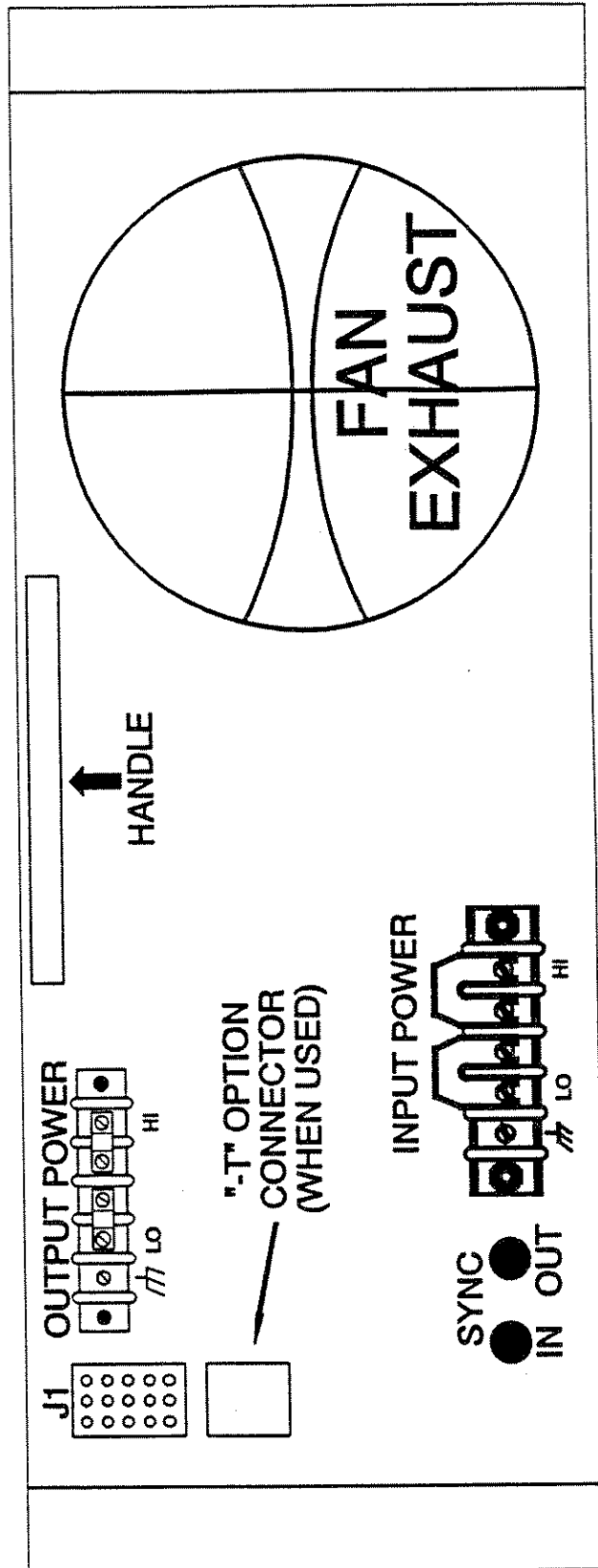

Figure 2-10. Model 501SX (Rear View)

**2.6 MODEL 1001SX
INSTALLATION**

The Model 1001SX AC Power Source is designed for installation in a standard 19" (483 mm) instrument rack (refer to Figures 2-11 through 2-13 for outline drawings, mounting dimensions and the location of controls and connectors).

The Model 1001SX must be installed such that the flow of cooling air into the side panel grills and out the rear panel is not obstructed. For slide out capability, the unit is equipped with threaded inserts located on each side for mounting slides.

2.6.1 Input Power Requirements

The standard Model 1001SX operates from 115 VAC, 208 VAC, or 230 VAC single phase input power at 47 Hz to 63 Hz. The input power terminal block is located on the rear panel (refer to Figure 2-13 for location). Figure 2-1 provides input voltage connection options.

2.6.2 Output Power Connections

Output power is provided at a terminal block located on the rear panel of the unit (refer to Figure 2-13 for location). A listing of available output power can be found in Table 2-1. Figure 2-2 provides output voltage connection options.

2.6.3 Sync Out BNC Connectors

The Model 1001SX can be optionally equipped with BNC-type 'Sync' connectors located on the rear panel of the unit (refer to Figure 2-13 for location).

2.6.4 Installing The Model 1001SX

To install the Model 1001SX AC Power Source, perform the following:

1. Before installing the power source, verify that the input and output voltage ranges are compatible with the available utility power and the output voltage application. Refer to Figures 2-12 and 2-13, Table 2-1, and the unit serial number tag for model number information.
2. The power source is designed for installation in a standard 19" (483 mm) RETMA electronic equipment rack. Install the power source in the appropriate rack such that the flow of cooling air into and out of the unit is unobstructed. Allow 6" (152 mm) clearance at the rear of the unit.
3. Position the POWER switch-circuit breaker to OFF (down).
4. Insert the appropriate Elgar oscillator, which provides control over output voltages and frequencies, into the front panel in accordance with the appropriate oscillator Operating Manual.
5. Connect the output load to the rear panel output terminal block (TB2). For initial installation, a dummy load should be used until the unit is completely checked out and verified as operational.
6. Connect the input power to the rear panel input power terminal block (TB1) (refer to Figure 2-1 for input voltage connection options).

2.6.5 Model 1001SX Preliminary Functional Checkout

To check the Model 1001SX AC Power Source after initial installation, perform the following:

1. Position the POWER switch-circuit breaker to ON (up). Observe that the POWER On indicator is illuminated (green).
2. Ensure that the fan is exhausting air through the rear panel grill.
3. Set the Elgar oscillator to the desired amplitude and frequency (refer to the oscillator's Operating Manual for specific instructions).
4. Position the POWER switch-circuit breaker to OFF (down). Observe that the Power On indicator is no longer illuminated and that the fan turns off.

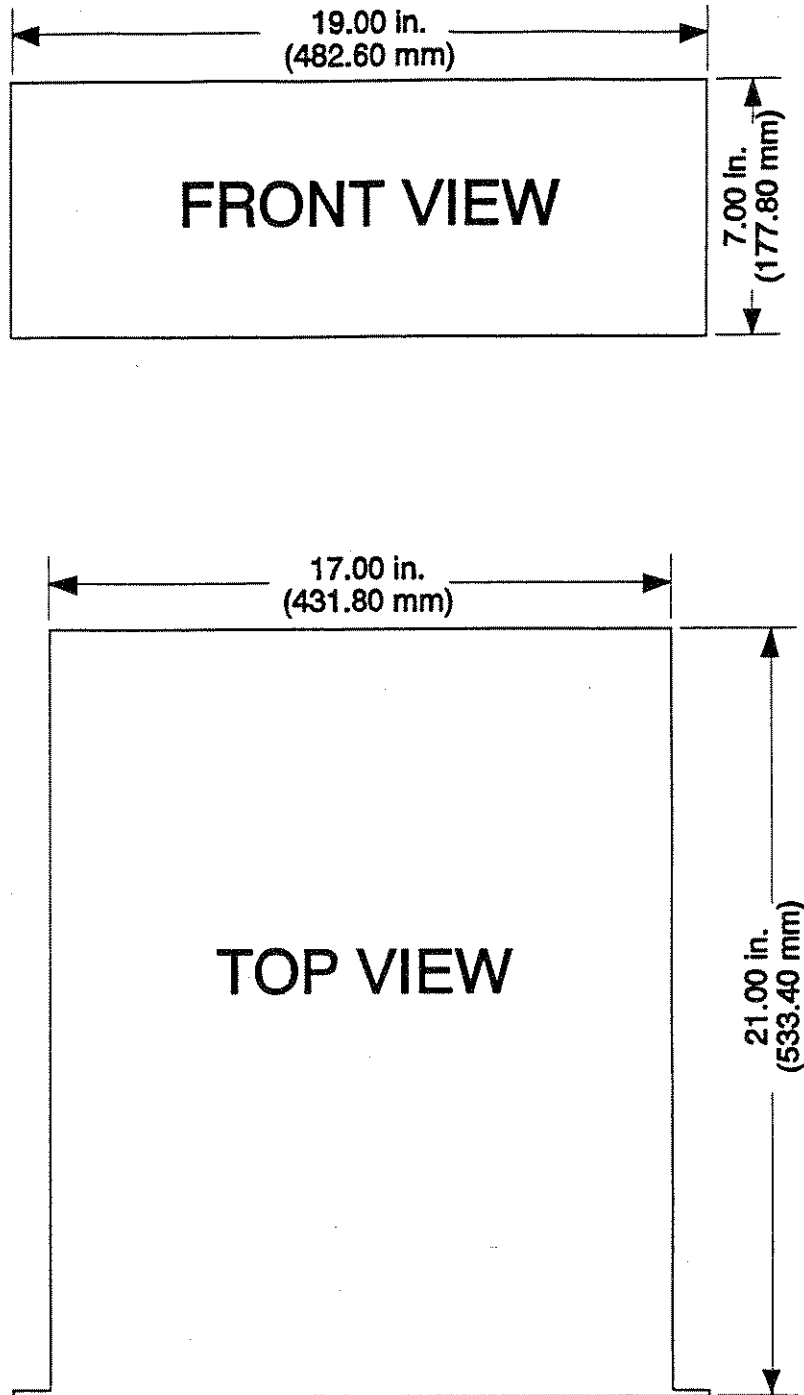

Figure 2-11. Model 1001SX Installation Dimensions

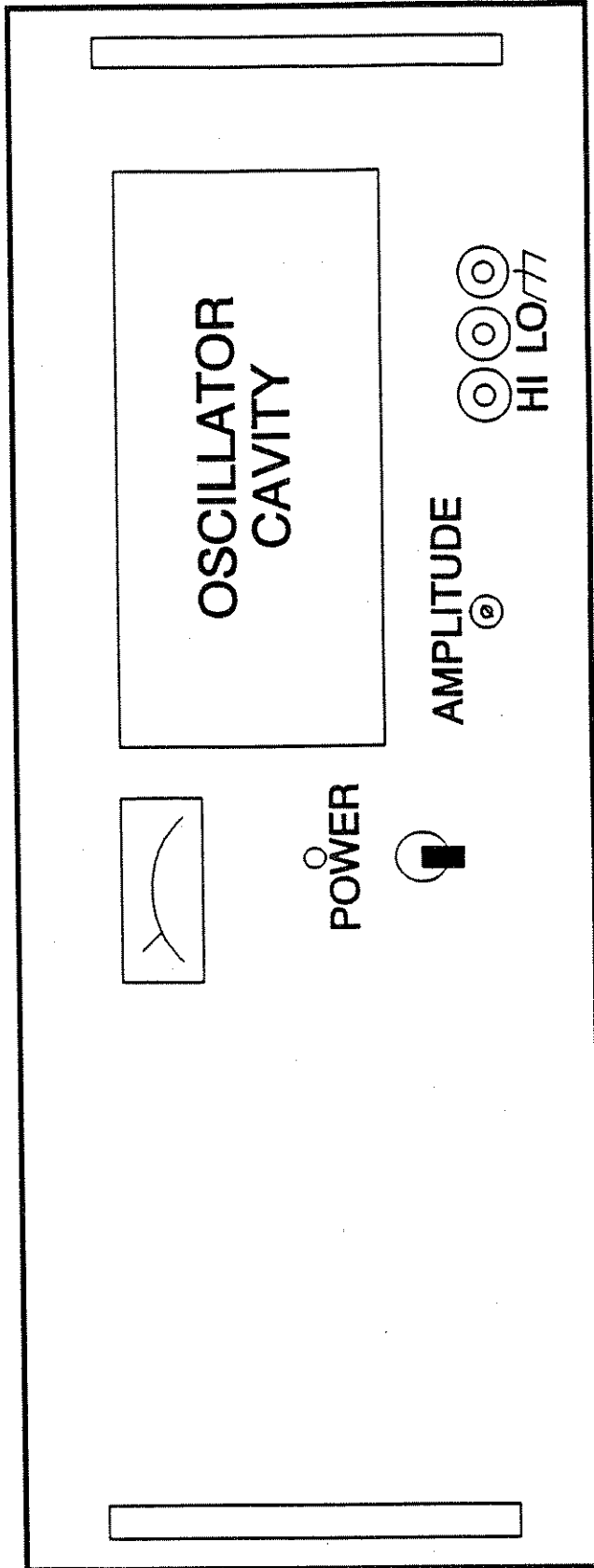

Figure 2-12. Model 1001SX (Front View)

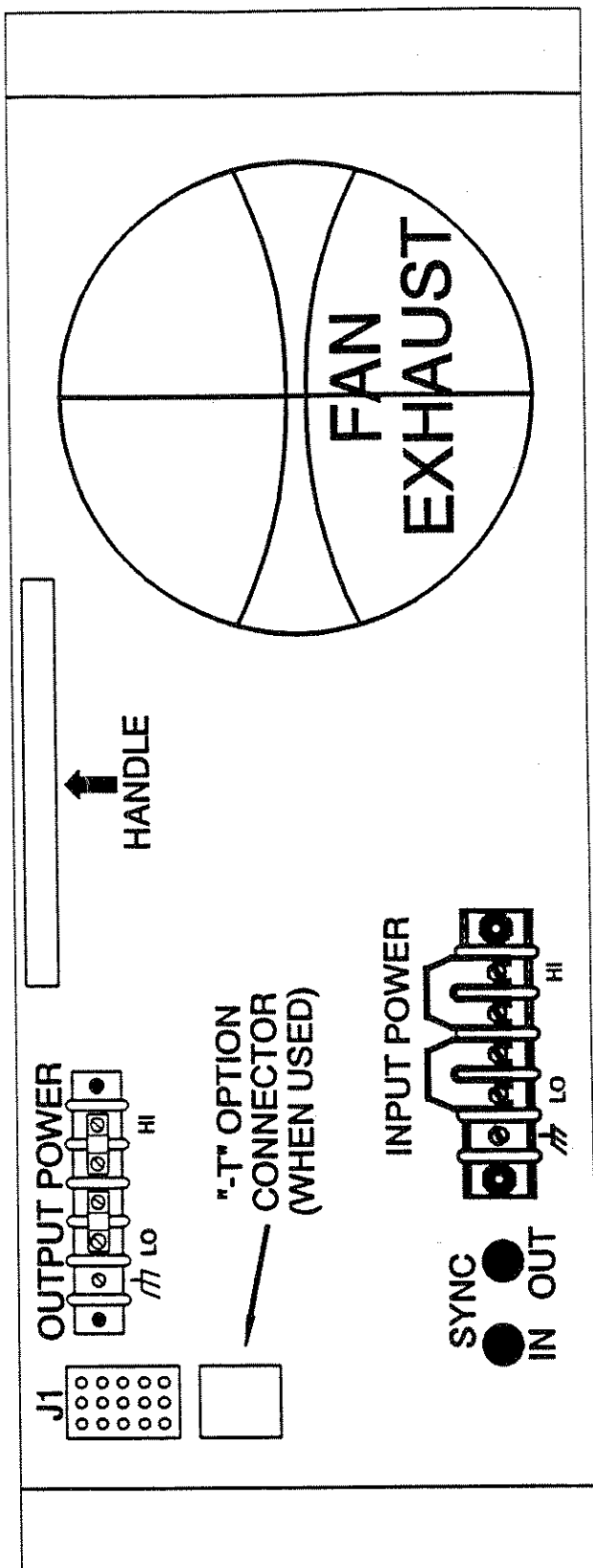

Figure 2-13. Model 1001SX (Rear View)

**2.7 MODEL 1751SX
INSTALLATION**

The Model 1751SX AC Power Source is designed for installation in a standard 19" (483 mm) instrument rack (refer to Figures 2-14 through 2-16 for outline drawings, mounting dimensions and the location of controls and connectors).

The Model 1751SX must be installed such that the flow of cooling air into the side panel grills and out the rear panel is not obstructed. For slide out capability, the unit is equipped with threaded inserts located on each side for mounting slides.

2.7.1 Input Power Requirements

The standard Model 1751SX operates from 115 VAC, 208 VAC, or 230 VAC single phase input power at 47 Hz to 63 Hz. The input power terminal block is located on the rear panel (refer to Figure 2-16 for location). Figure 2-1 provides input voltage connection options.

2.7.2 Output Power Connections

Output power is provided at a terminal block located on the rear panel of the unit (refer to Figure 2-16 for location). A listing of available output power can be found in Table 2-1. Figure 2-2 provides output voltage connection options.

2.7.3 Sync Out BNC Connectors

The Model 1751SX can be optionally equipped with BNC-type 'Sync' connectors located on the rear panel of the unit (refer to Figure 2-16 for location).

2.7.4 Installing The Model 1751SX

To install the Model 1751SX AC Power Source, perform the following:

1. Before installing the power source, verify that the input and output voltage ranges are compatible with the available utility power and the output voltage application. Refer to Figures 2-14 and 2-15, Table 2-1, and the unit serial number tag for model number information.
2. The power source is designed for installation in a standard 19" (483 mm) RETMA electronic equipment rack. Install the power source in the appropriate rack such that the flow of cooling air into and out of the unit is unobstructed. Allow 6" (152 mm) clearance at the rear of the unit.
3. Position the POWER switch-circuit breaker to OFF (down).
4. Insert the appropriate Elgar oscillator, which provides control over output voltages and frequencies, into the front panel in accordance with the appropriate oscillator Operating Manual.
5. Connect the output load to the rear panel output terminal block (TB2). For initial installation, a dummy load should be used until the unit is completely checked out and verified as operational.
6. Connect the input power to the rear panel input power terminal block (TB1) (refer to Figure 2-1 for input voltage connection options).

2.7.5 Model 1751SX Preliminary Functional Checkout

To check the Model 1751SX AC Power Source after initial installation, perform the following:

1. Position the POWER switch-circuit breaker to ON (up). Observe that the POWER On indicator is illuminated (green).
2. Ensure that the fans are exhausting air through the rear panel grill.
3. Set the Elgar oscillator to the desired amplitude and frequency (refer to the oscillator's Operating Manual for specific instructions).
4. Position the POWER switch-circuit breaker to OFF (down). Observe that the Power On indicator is no longer illuminated and that the fans turn off.

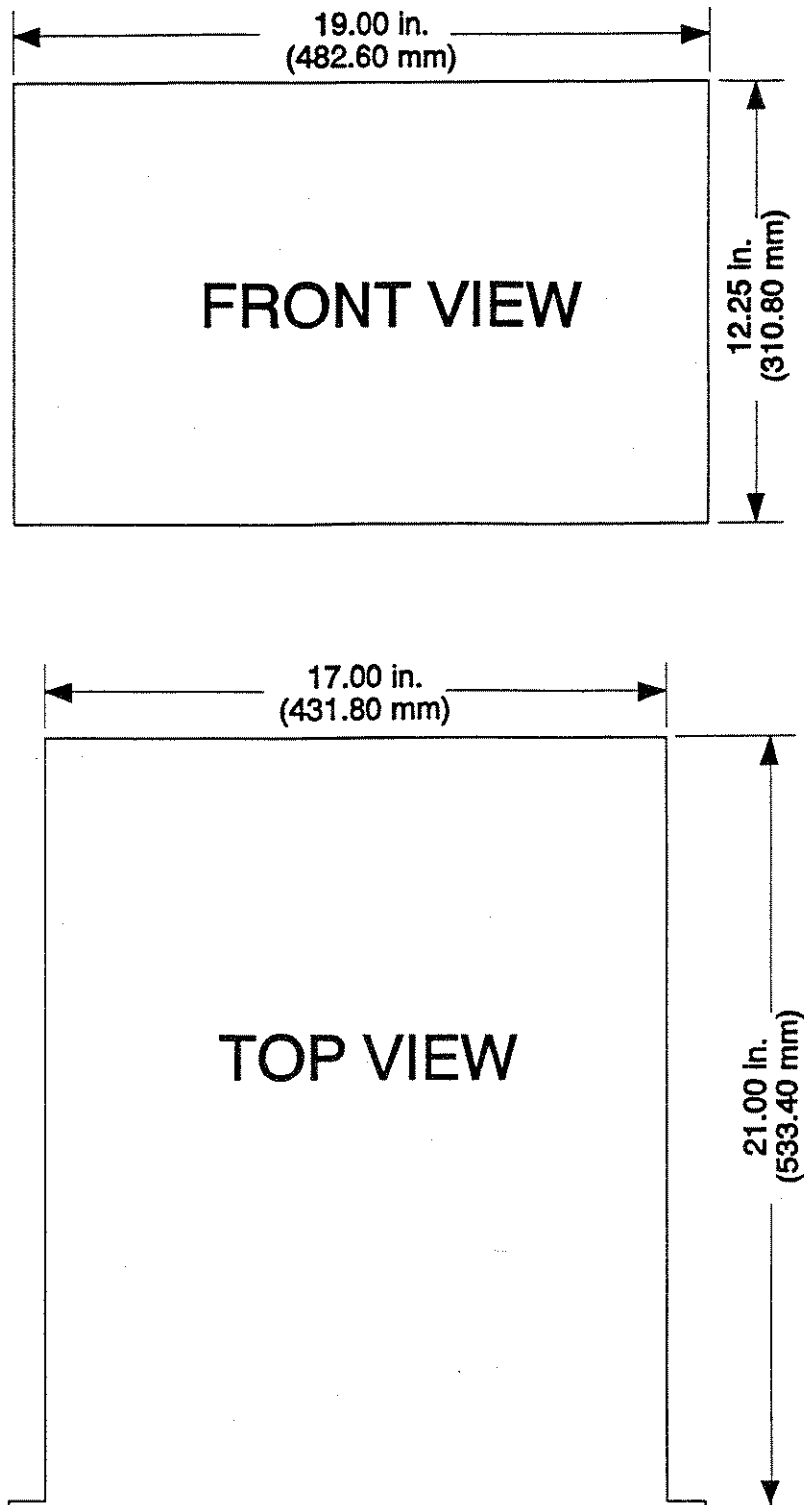

Figure 2-14. Model 1751SX Installation Dimensions

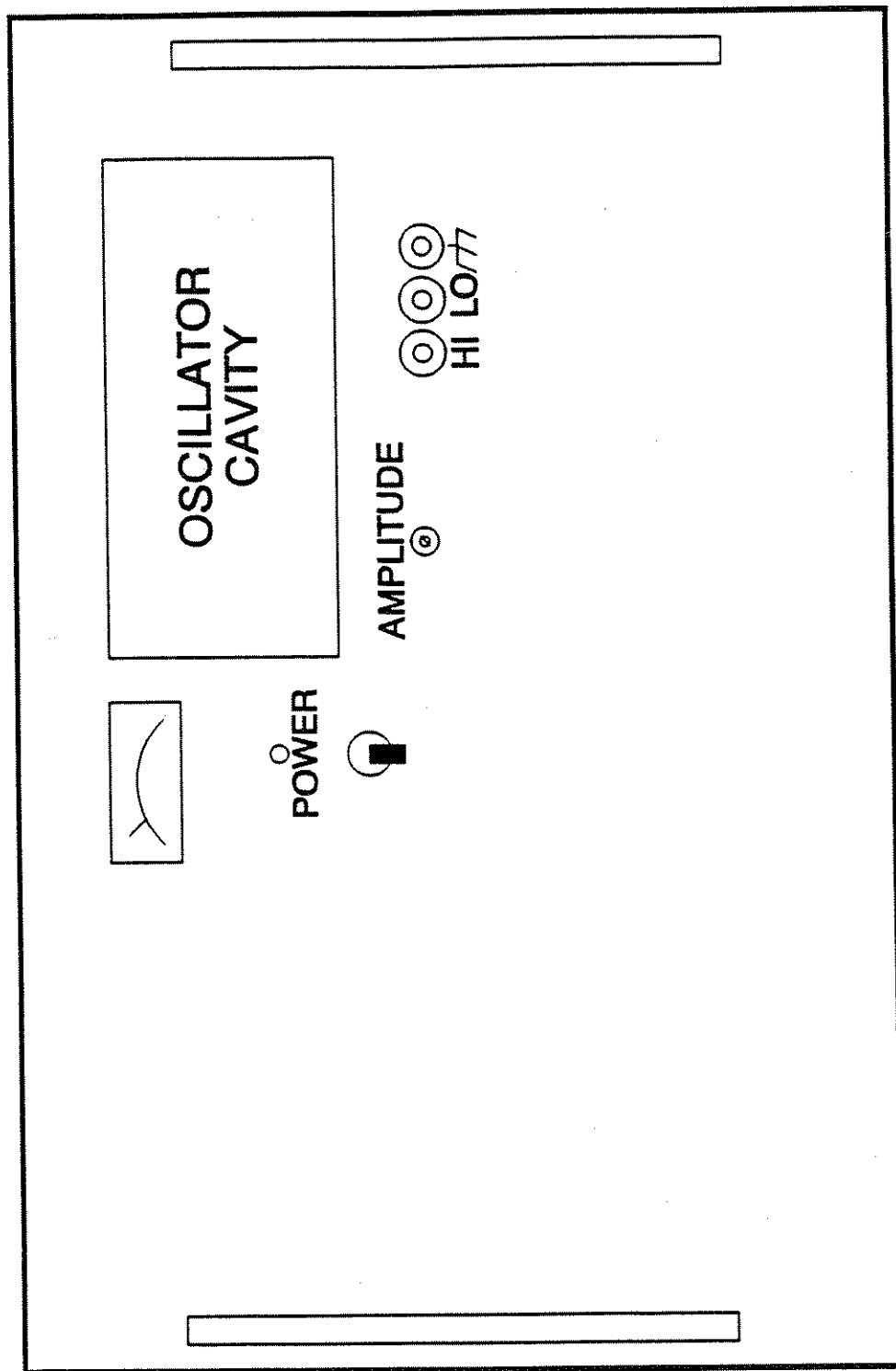

Figure 2-15. Model 1751SX (Front View)

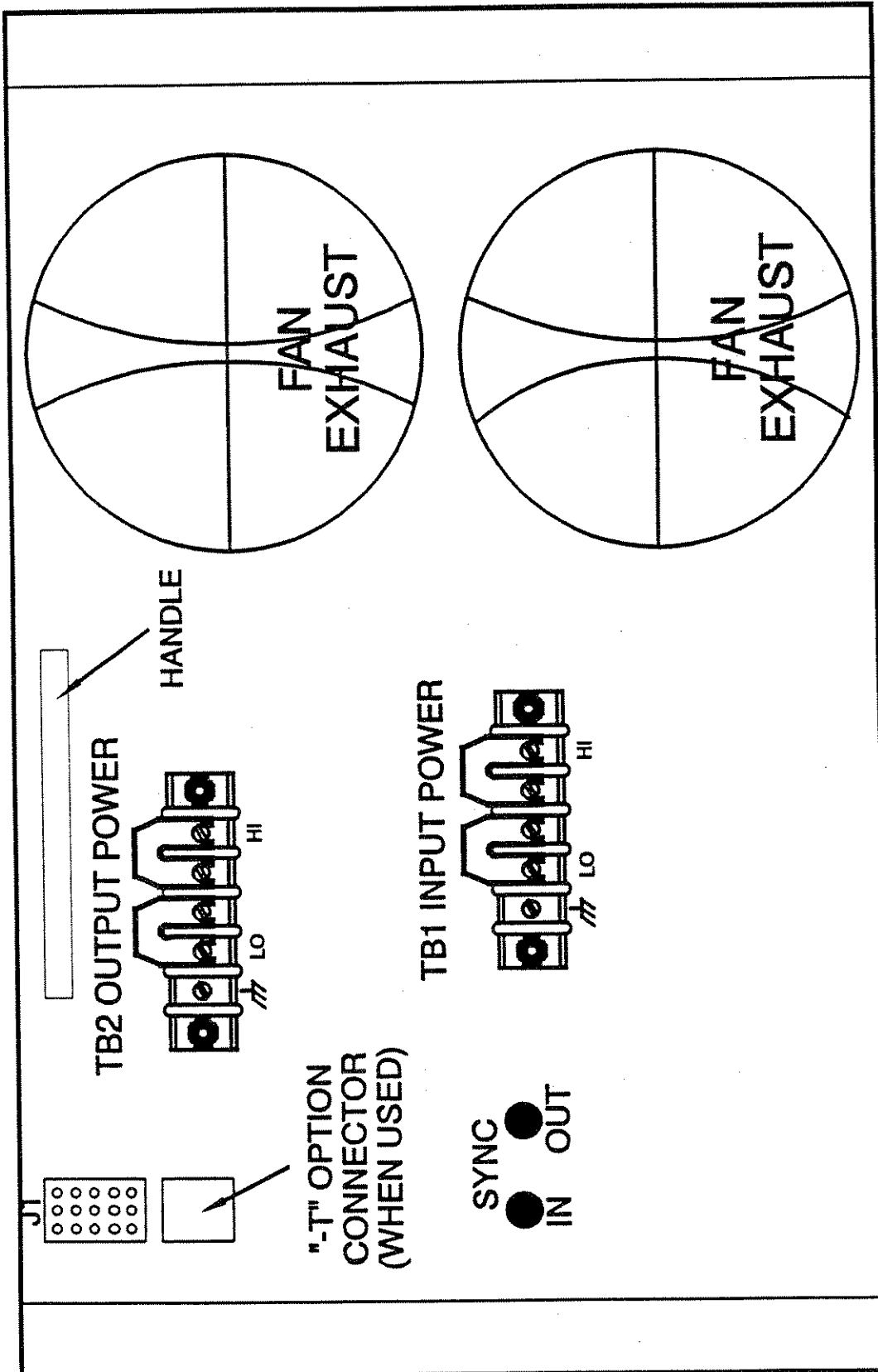

Figure 2-16. Model 1751SX (Rear View)

2.8 SYSTEM INTERCONNECTION**2.8.1 Multi-Phase Operation**

Two or three power sources may be inter-connected to generate two or three phase AC power (refer to Table 2-2 for further information).

NOTE

Table 2-2 utilizes the 400 Series oscillators (refer to paragraph 2.8.3). Refer to the appropriate PIP Operating Manual if a PIP is utilized.

Two or three phase signals are developed by a multi-phase oscillator installed in the A Phase power amplifier. Signals from the oscillator are routed to the B Phase and/or C Phase power amplifiers through a signal interconnect cable. These signals are then applied to the front panel AMPLITUDE control on each amplifier by a signal routing plug-in which must be installed in the unit. Upon initial calibration of the system, the voltage of Phase A is adjusted to a desired value, i.e., 115 VAC. The other phase amplifier(s) output voltages are then adjusted by means of their front panel amplitude controls to equal the output voltage of Phase A. After this initial calibration has been accomplished, the voltage control on the Phase A amplifier is used to vary the output voltage of all phases simultaneously and equally.

Two phase operation requires two power sources. Three phase operation may be accomplished with three power sources, two power sources in open delta configuration, or two power sources in phantom wye configuration. Refer to Figure 2-17 for output interconnect information for the various systems.

In the open delta configuration, two power amplifiers of equal VA rating are driven by a standard three phase oscillator having a 120° phase angle between Phase A, Phase B, and Phase C. An open delta requires that the two amplifiers have a 60° phase angle between them. This is accomplished by inverting the output from the second amplifier.

In these systems, the amplifier containing the plug-in oscillator is referred to as the Master or Phase A source. The second amplifier is referred to as the Slave or Phase B source.

The vector diagram for the open delta connection is shown in Figure 2-18.

Table 2-2. 1-, 2-, or 3-Phase Using Two or Three AC Power Sources

System Model	Power Source(s)	Plug-In Standard	Plug-In Servo	Cable Standard	Cable Servo
1000SX-1	501SX(2)	400BT	400DPA	5970042	5970030
1000SX-2	501SX(2)	400C	400DPC	5970042	5970030
1000SX-3D	501SX(2)	400C	400DPC	5970042	5970030
1500SX-3	501SX(3)	400B, 400C	400DPB, 400DPC	5970041	5970029
2000SX-1	1001SX(2)	400BT	400DPA	5970042	5970030
2000SX-2	1001SX(2)	400C	400DPC	5970042	5970030
2000SX-3D	1001SX(2)	400C	400DPC	5970042	5970030
3000SX-3	1001SX(3)	400B, 400C	400DPB, 400DPC	5970041	5970029
3500SX-1	1751SX(2)	400BT	400DPA	5970042	5970030
3500SX-2	1751SX(2)	400C	400DPC	5970042	5970030
3500SX-3D	1751SX(2)	400C	400DPC	5970042	5970030
5250SX-3	1751SX(3)	400B, 400C	400DPB, 400DPC	5970041	5970029

NOTES:

1. A three digit dash number may be used to identify system input, output or special functions. Refer to Figure 1-3 for information.

EXAMPLE: 3000SX-3-11T will be a 115 VAC input, 130/260 VAC output with T-option monitoring AC Power Source System.

2. An additional plug-in master oscillator is required to complete the system, such as a Model PIP 9012-3, a 3 phase oscillator would be used in a 3000SX-3 system.
3. An additional cable, 5970014, is required for auxiliary signal interconnect when a D-option is installed in a 3 amplifier system.

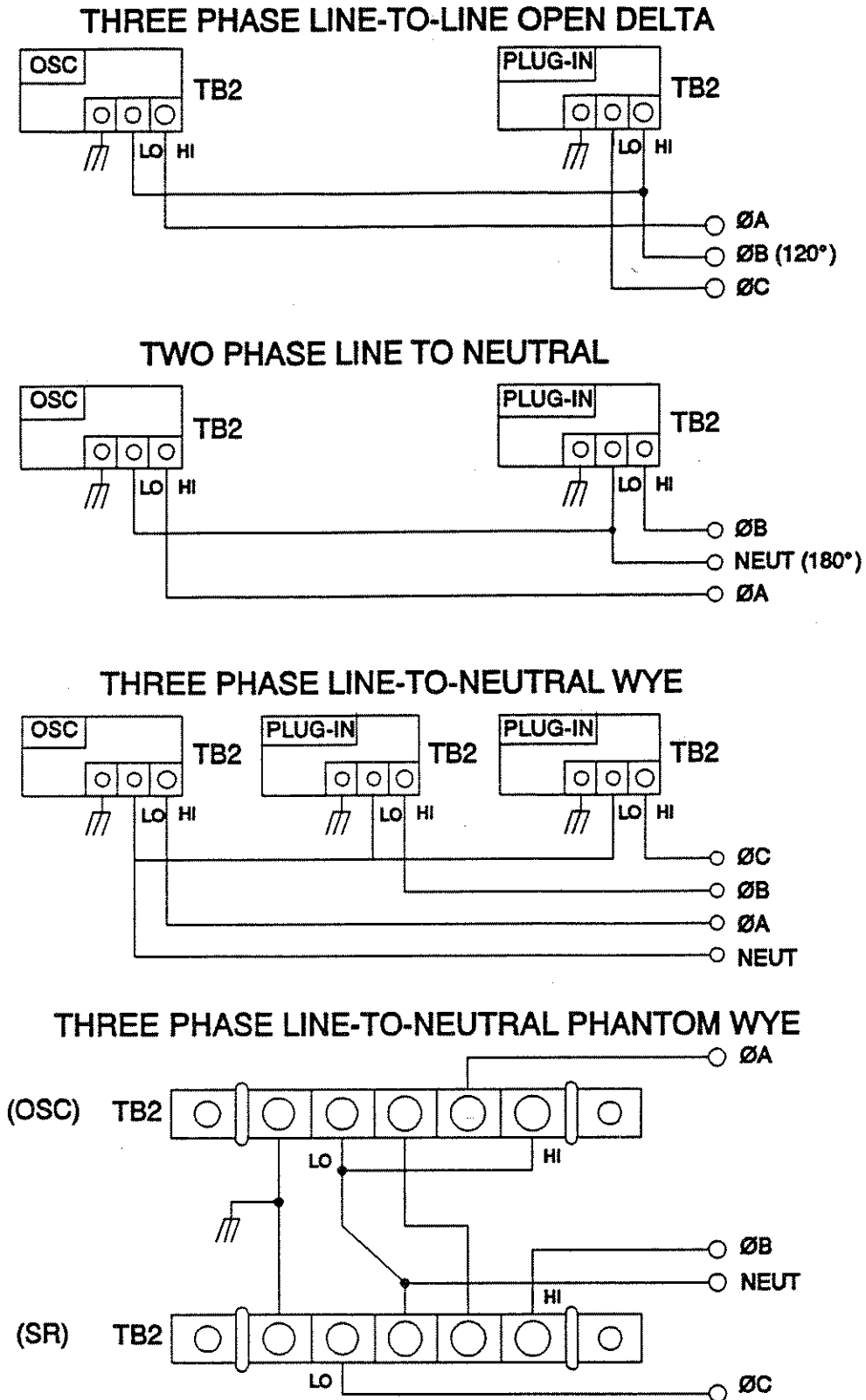

Figure 2-17. System Interconnections

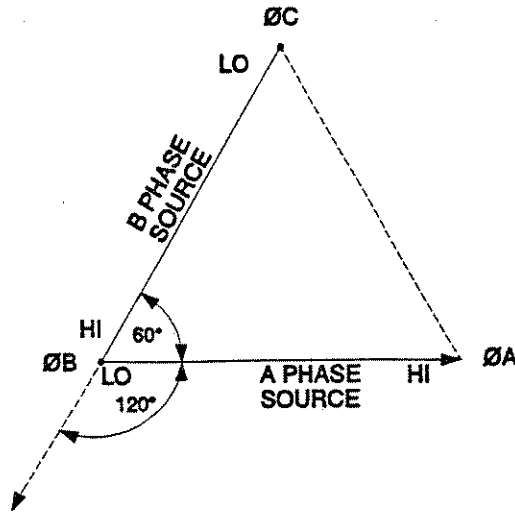

Figure 2-18 Open Delta Vector Diagram

2.8.2 Model 400SR Configuration Switch

The Model 400SR plug-in is a universal signal routing plug-in used in multi-phase systems to route drive signals from a master plug-in oscillator or an external oscillator source (refer to Figure 2-19). The routing is accomplished by the closing of specified switches on the 8 pole switch.

THE MODEL 400SR CONTAINS AN 8 POLE SWITCH, S1, THAT IS USED TO SELECT 1 OF 7 CONFIGURATIONS.

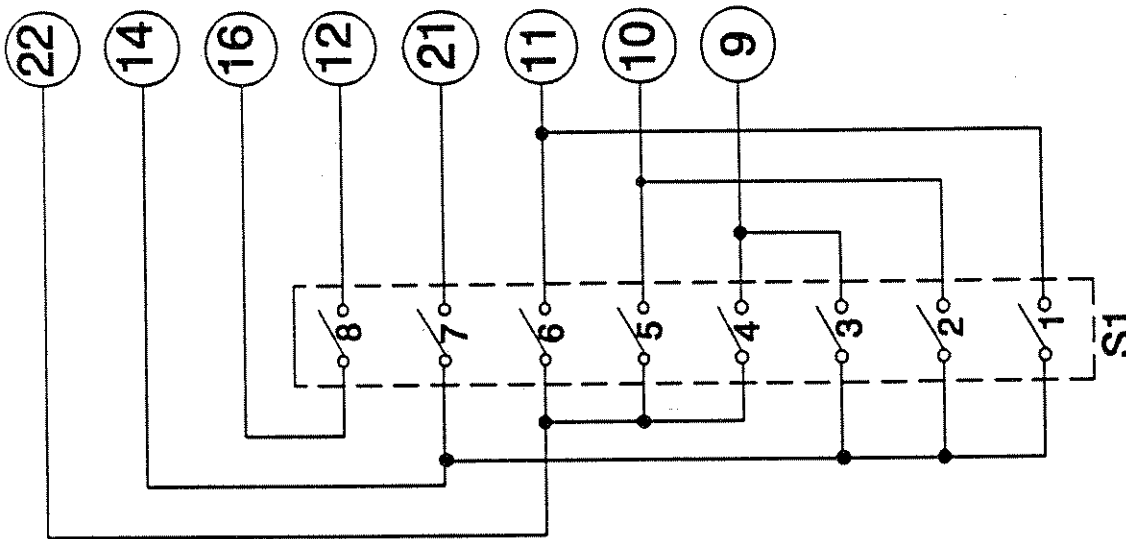

Figure 2-19. Model 400SR Configuration Switch, S1

2.8.3 Model 400 Series Plug-In Oscillators

Standard plug-ins are discussed in paragraphs 2.8.2.1 through 2.8.2.7 (refer to the appropriate PIP Operating Manual if a PIP is utilized).

2.8.3.1 Model 400A

External oscillator adaptor (refer to Figure 2-20). Has a front panel phone jack and routes the signal to the power amplifier input. A DIP switch is not necessary. If a DIP switch is present, switches 7 and 8 must be ON, connecting pins 14 to 21 and 16 to 12.

2.8.3.2 Model 400B

Blank plug-in used in the second amplifier (B Phase) of a multi-phase system (refer to Figure 2-21). Routes the appropriate signal from the oscillator in the first amplifier to the

second amplifier input. Switches 6, 7 and 8 must be ON, connecting pins 22 to 11, 21 to 14, and 16 to 12.

2.8.3.3 Model 400C

Blank plug-in used in the third amplifier (C Phase) of the 3 amplifier, 3 phase system (refer to Figure 2-22). Routes the appropriate signal from the oscillator in the first amplifier to the third amplifier input. Switches 5, 7, and 8 must be ON, connecting pins 22 to 10, 21 to 14, and 16 to 12.

2.8.3.4 Model 400DPA

Blank plug-in used in certain single phase PIP or servo controlled systems as a Phase A signal routing (refer to Figure 2-23). Switches 4 and 8 must be ON connecting pins 14 to 9, and 16 to 12.

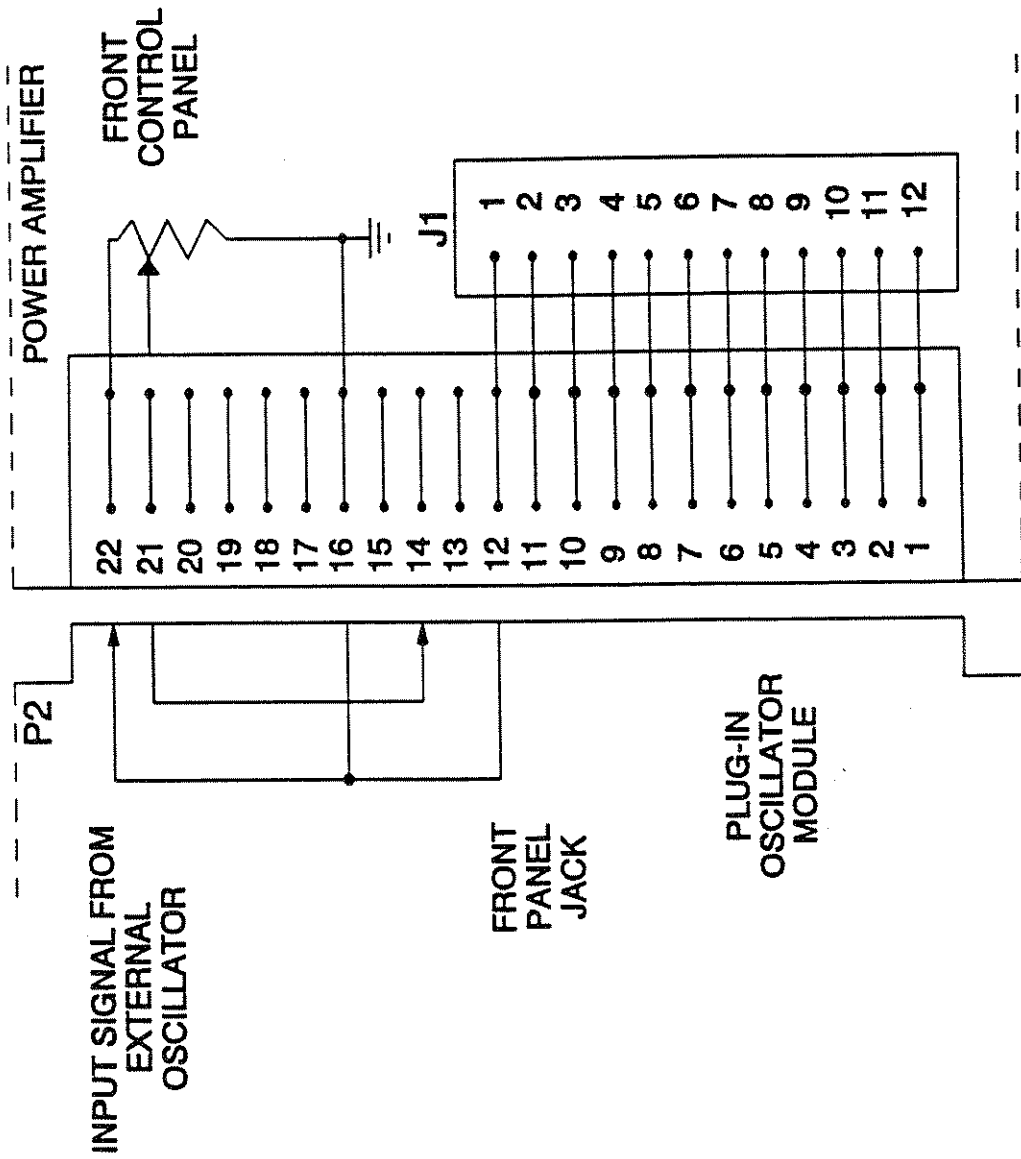

Figure 2-20. 400A Signal Routing Plug-In

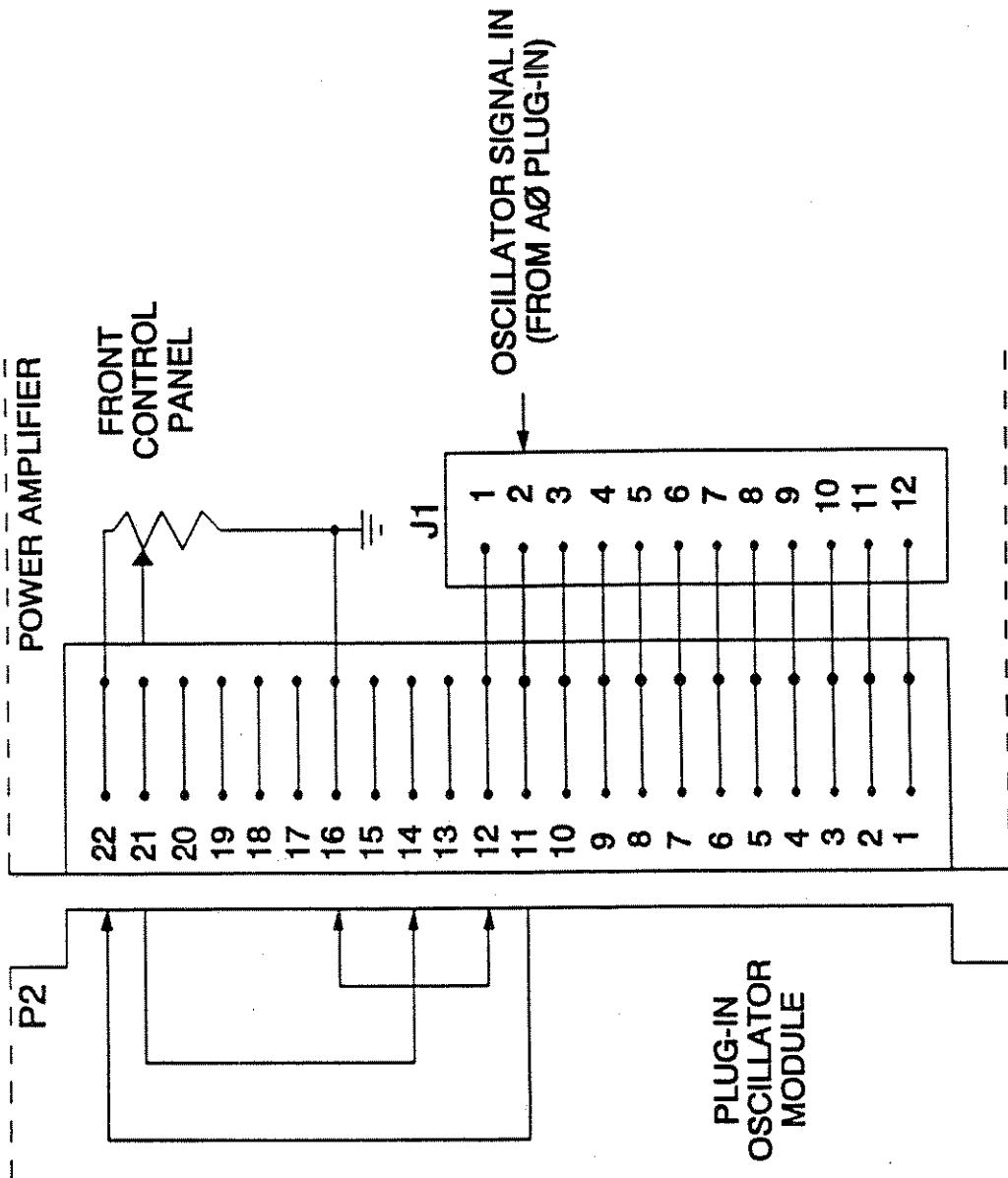

Figure 2-21. 400B Signal Routing Plug-In

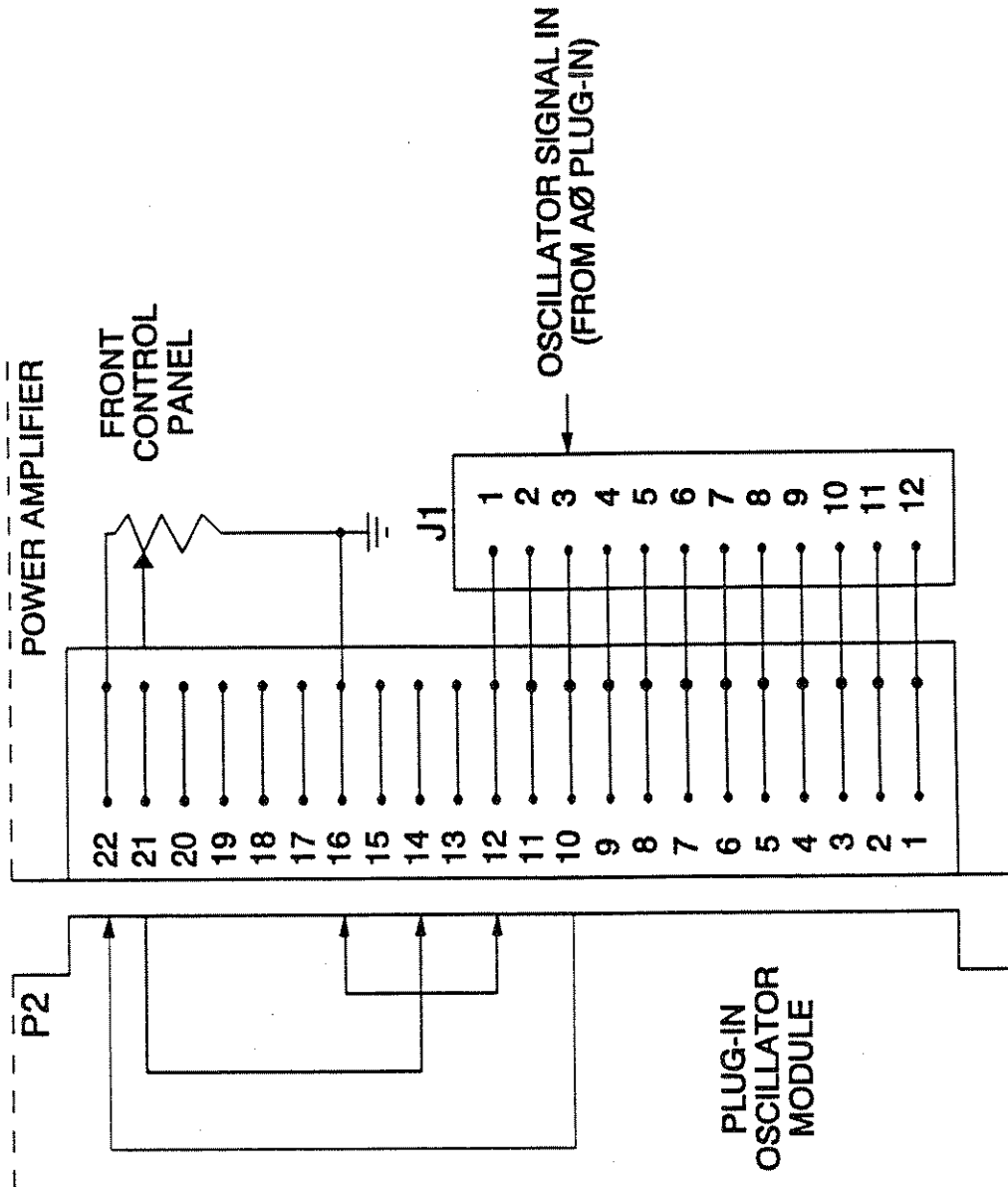

Figure 2-22. 400C Signal Routing Plug-In

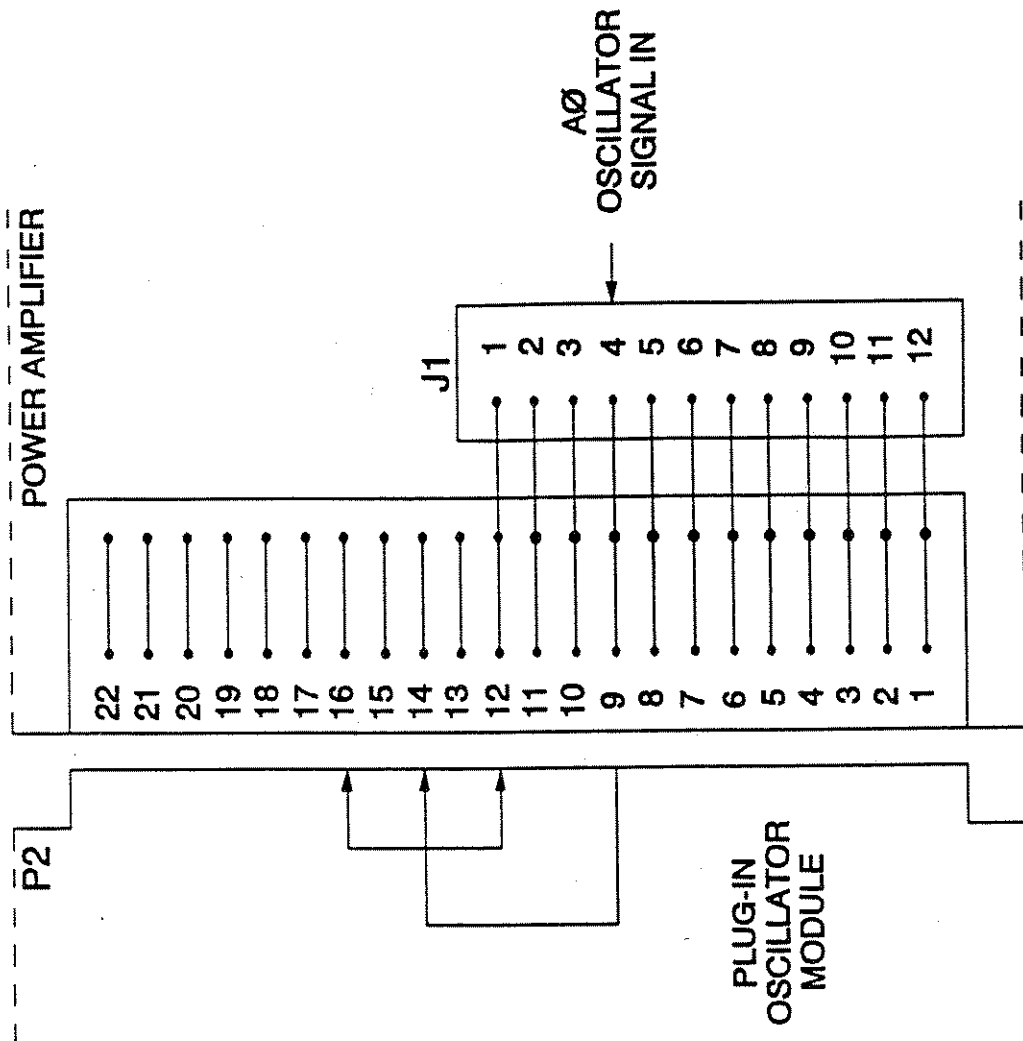

Figure 2-23. 400DPA Signal Routing Plug-In

2.8.3.5 Model 400DPB

Blank plug-in used in Phase B of a multi-phase PIP or in servo controlled oscillator systems (refer to Figure 2-24). Switches 1 and 8 must be ON, connecting pins 14 to 11 and 16 to 12.

2.8.3.6 Model 400DPC

Blank plug-in used in Phase C of a multi-phase PIP or in servo controlled oscillator systems (refer to Figure 2-25). Switches 2 and 8 must be ON, connecting pins 14 to 10 and 16 to 12.

2.8.3.7 Model 400BT

Blank plug-in for second amplifier(s) in a tandem system, such as a 2000SX-1 (refer to Figure 2-26). Also used in single phase TG704A systems or in Phase A of multi-phase TG704A-3 systems. Switches 4, 7, and 8 must be ON, connecting pins 22 to 9, 21 to 14, and 16 to 12.

2.8.4 Interconnect Diagrams

Refer to Figure 2-27 for information concerning a 3 amplifier, 3 phase system with a servo oscillator.

Refer to Figure 2-28 for information concerning a 3 amplifier, 3 phase system with D-option, servo control.

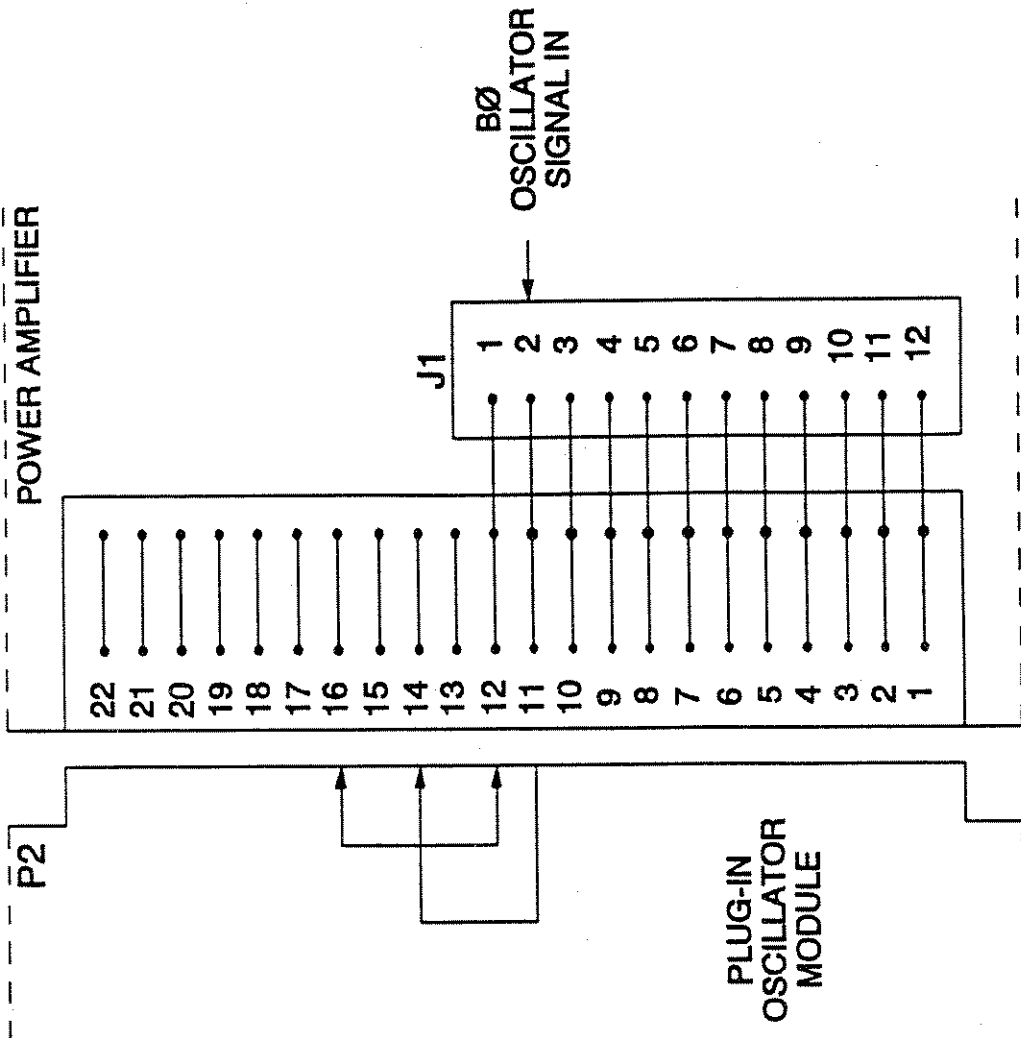

Figure 2-24. 400DPB Signal Routing Plug-In

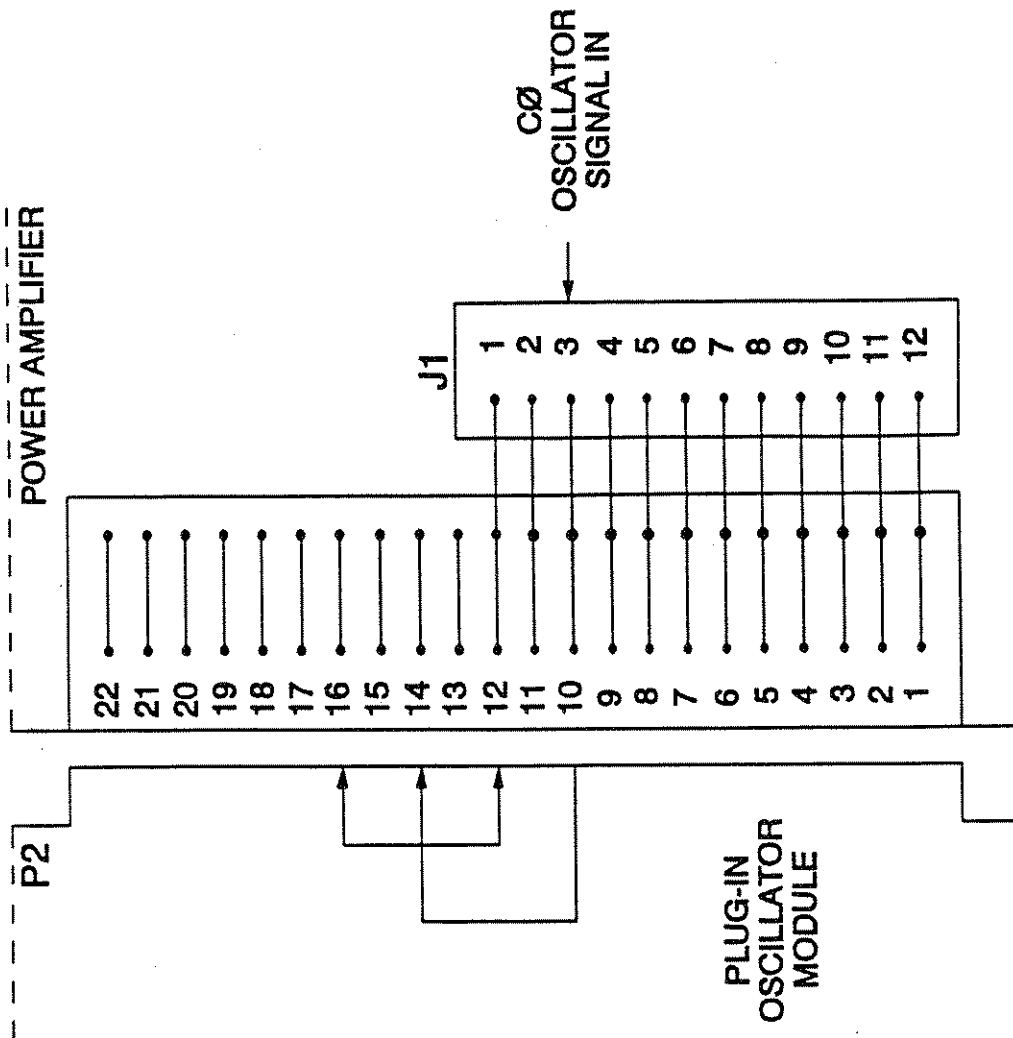

Figure 2-25. 400DPC Signal Routing Plug-In

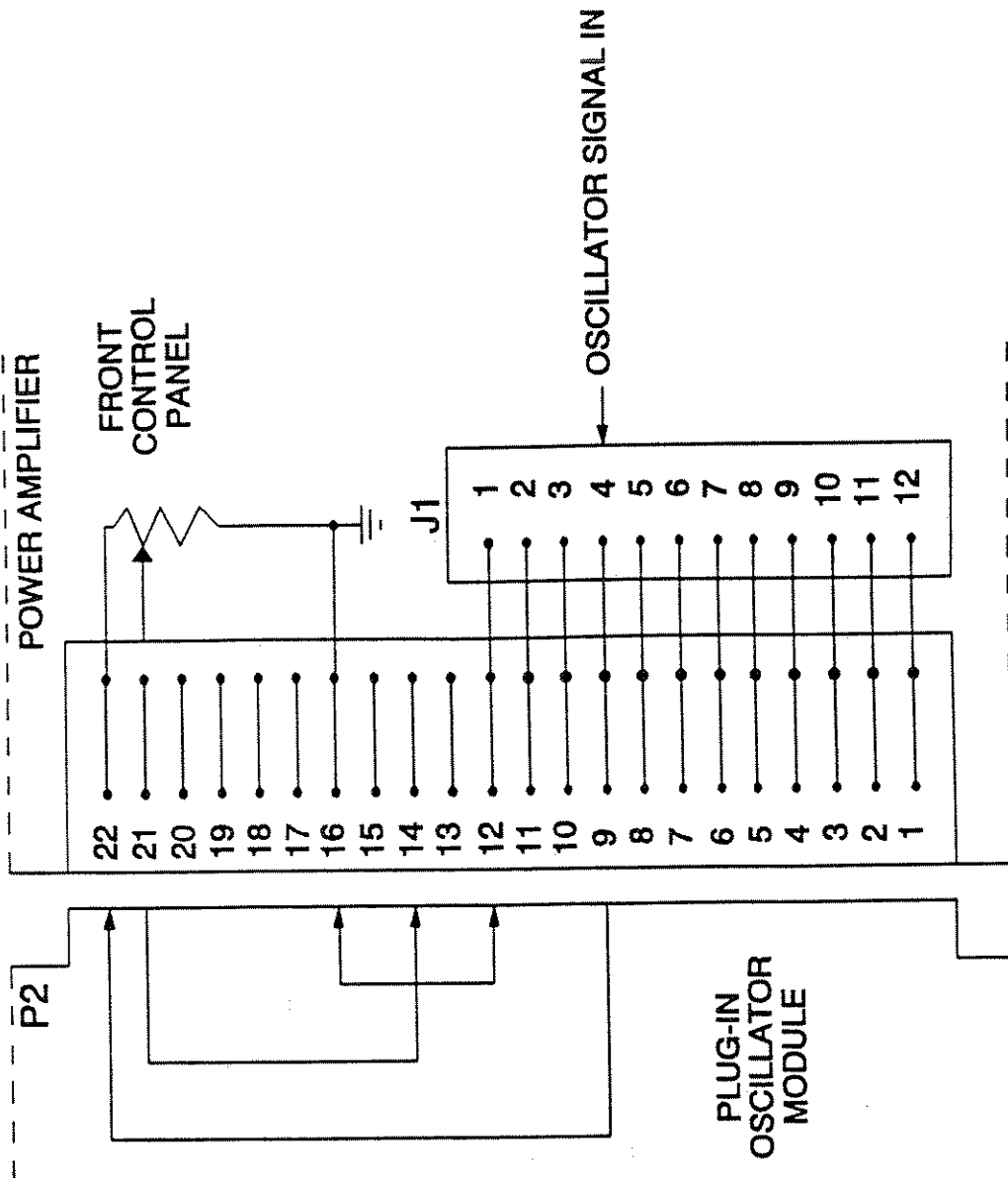
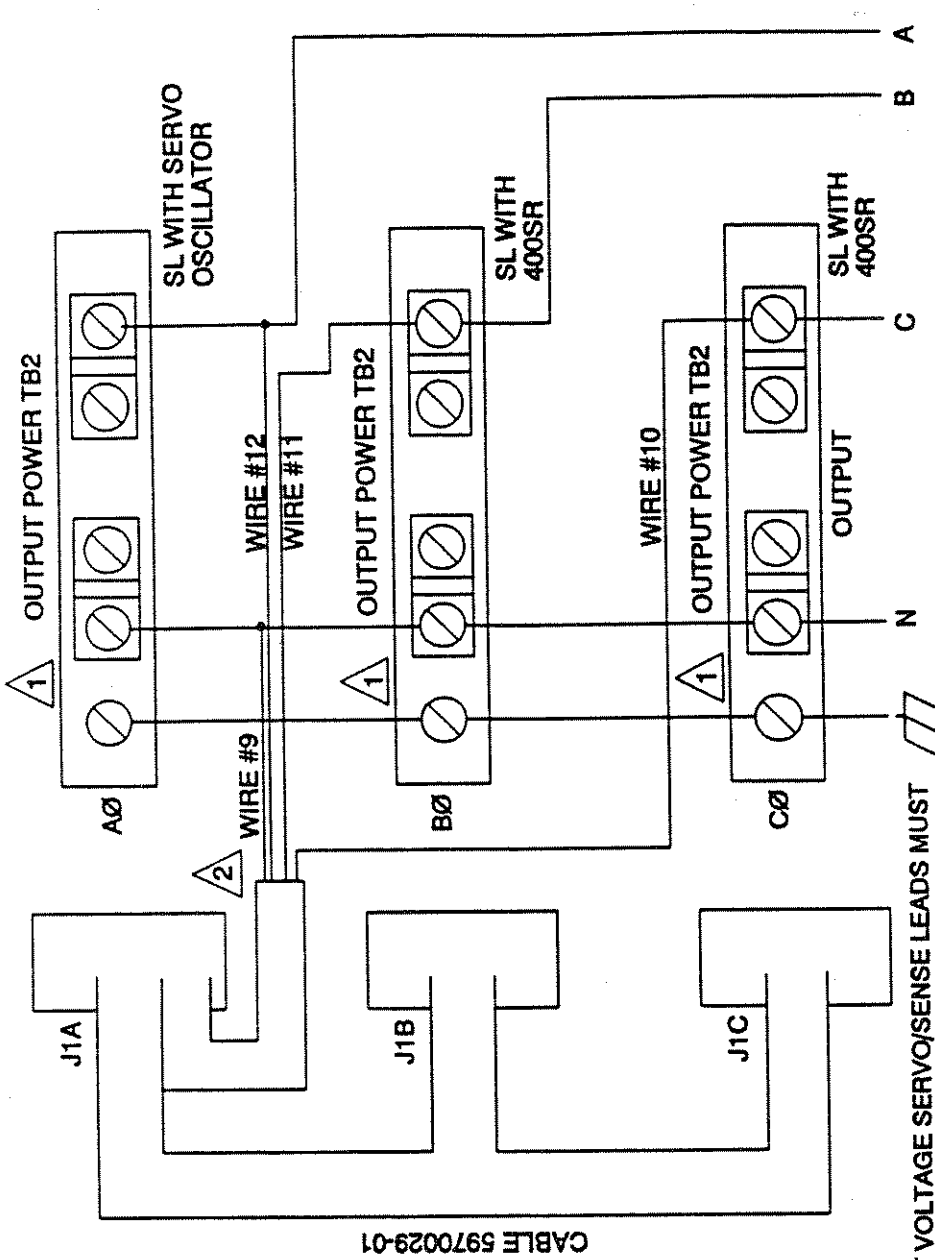

Figure 2-26. Model 400BT Signal Routing Plug-In Connections



3 AMPLIFIER SL, 3 PHASE SYSTEM
WITH SERVO OSCILLATOR

⚠️ OUTPUT VOLTAGE SERVO/SENSE LEADS MUST
BE CONNECTED AT THE LOAD TO ACHIEVE
LINE/LOAD REGULATION SPECIFICATIONS.

⚠️ 0-130 VAC SHOWN. REFER TO SECTION 1 FOR
OUTPUT OPTIONS.

NOTES: UNLESS OTHERWISE SPECIFIED.

Figure 2-27. System Output/Signal Interconnect

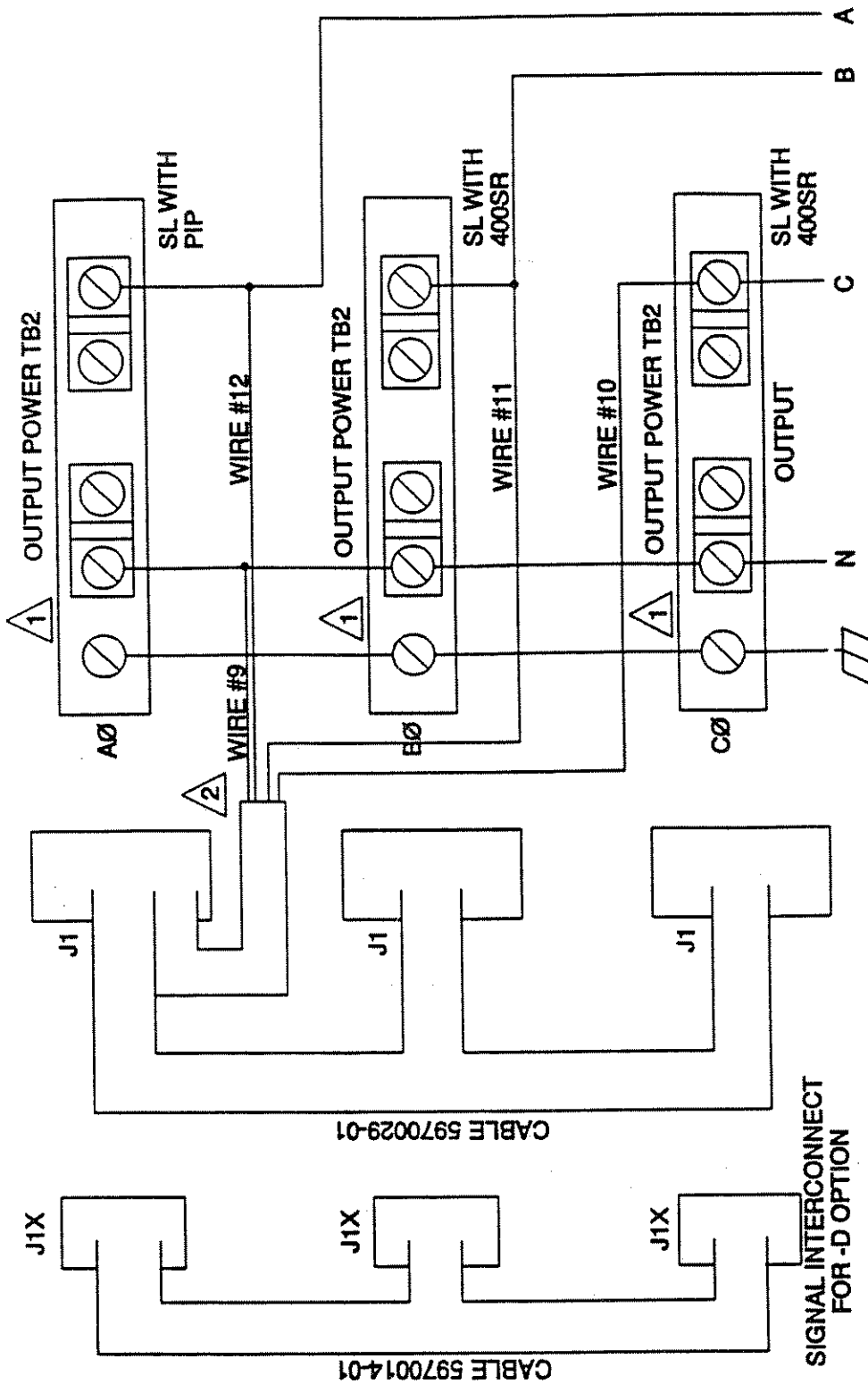

3 AMPLIFIER SL, 3 PHASE SYSTEM WITH -D OPTION, SERVO CONTROL

2 OUTPUT VOLTAGE SERVO/SENSE LEADS MUST BE CONNECTED AT THE LOAD TO ACHIEVE LINE/LOAD REGULATION SPECIFICATIONS.

1 0-130 VAC SHOWN. REFER TO SECTION 1 FOR OUTPUT OPTIONS.

NOTES: UNLESS OTHERWISE SPECIFIED.

Figure 2-28. System Output/Signal Interconnect With -D Option

3.1 INTRODUCTION

Before operating the power source, the user must become familiar with the particular model and configuration. The different models, configurations and options available are discussed in Sections I and II of this manual.

3.2 MANUAL OPERATION

After the power source has been installed in accordance with the instructions in Section II, the power source can be manually adjusted for the desired value of output voltage via the AMPLITUDE control on the front panel. The power source requires a plug-in oscillator or signal source. If the oscillator or signal source is fixed frequency, no adjustment is necessary. If the oscillator or signal source is variable, it must be set to the desired value. Ensure the frequency is set within the limits of the power source as outlined in Section II.

3.3 GPIB OPERATION

SX Series AC Power Sources meet all the requirements of MATE-STD-280673, including built in TMA for CIIL/ATLAS interfacing. The signal required to operate the SX Series AC Power Source is provided by an Elgar PIP oscillator. The PIP is connected to the GPIB interface on the rear panel of the power source. Refer to the Operating Manual for the PIP installed for information on programming the power source via GPIB.

3.4 CONTROLS AND INDICATORS

Refer to Figure 2-9 for an illustration of the Model 501SX front panel; to Figure 2-12 for an illustration of the Model 1001SX front panel; or to Figure 2-15 for an illustration of the Model 1751SX front panel.

3.4.1 Output Voltage Meter

The Output Voltage Meter indicates the output voltage.

3.4.2 Oscillator Cavity

This cavity is used for installation of the Elgar plug-in oscillator. Refer to the appropriate oscillator Operating Manual for specific installation and operating instructions.

3.4.3 POWER On Switch-Circuit Breaker

This two-position switch applies AC line input power to the unit when in the On (up) position. The switch-circuit breaker safeguards the unit by opening when the input current exceeds the rated value of the circuit breaker.

3.4.4 POWER On Indicator

This indicator is illuminated (green) when AC line input power is present in the unit when the POWER switch-circuit breaker is placed in the On (up) position. The indicator will extinguish when AC line power is removed from the unit.

3.4.5 AMPLITUDE Adjustment Screw

This screw is used to adjust the amplitude when a non-programmable oscillator is used. Voltage amplitude is controlled by rotating the screw to adjust the output voltage that is read on the Output Voltage Meter.

3.5 OPERATING INSTRUCTIONS**3.5.1 Power ON**

Perform the following:

1. Position the POWER switch-circuit breaker to On (up).
2. Observe that the POWER indicator illuminates (green) and remains illuminated.
3. Ensure that the fan(s) are operating.

3.5.2 Frequency Control

Perform the following:

1. Enter the desired frequency into the plug-in oscillator (refer to the appropriate oscillator Operating Manual for specific procedures).
2. Verify the setting.

3.5.3 Amplitude Control

Perform the following:

1. If a PIP is used, enter the desired amplitude into the plug-in oscillator (refer to the appropriate oscillator Operating Manual for specific procedures).
2. If a fixed oscillator is used, adjust the AMPLITUDE screw.
3. Verify the setting.

CAUTION

Do not continue operation of the power source if the POWER switch-circuit breaker trips when power is turned on or when the amplitude is increased. The power source is protected against shorts at the output terminals and recovers immediately when the short is removed. Tripping of the circuit breaker indicates that the unit requires adjustment or repair. Troubleshoot the power source in accordance with the Model 501SX/1001SX/1751SX Service Manual.

APPENDIX A

WIRE GAUGE SELECTION

The following guidelines assist in determining the optimum cable specification for the user's power applications. These guidelines are equally applicable to both DC and low frequency AC (up to 5 KHz) power cabling. The same engineering rules apply whether going into or out of an electrical device. Thus, this guide applies equally to the input cable and output cable for the ELGAR instrument and application loads.

Power cables must be able to safely carry maximum load current without overheating or causing insulation destruction. It is important to everyday performance to minimize IR (voltage drop) loss within the cable to a maximum of 1.5 volts total path. These losses have a direct effect on the quality (tight specifications) of power delivered to and from instruments and corresponding loads.

As a rule of thumb, specifying a generously larger power cable wire gauge has a negligible fiscal impact when compared to the costly investment in time and effort to evaluate and overcome both the cable deficiencies and the performance tradeoffs associated with a marginal (smaller) wire gauge.

When specifying wire gauge, the operating temperature needs to be considered.

Wire gauge current capability and insulation performance drops with increased temperature developed within a cable bundle and with increased environmental temperature. Thus, short cables with generously overrated gauge and insulation properties come well recommended for power source applications.

Avoid using published commercial utility wiring codes. These codes are designed for the internal wiring of homes and buildings and accommodate the safety factors of wiring loss heat, breakdown insulation, aging, etc. However, these codes consider that up to 5% voltage drop is acceptable.

Such a loss directly detracts from the quality performance specifications of the ELGAR instrument. Frequently, these codes do not consider bundles of wire within a cable arrangement.

Sense lines carry very little current and, thus, have negligible gauge overrating requirements. Sense lines tend to be particularly sensitive to induced voltages from nearby cables and from electrically noisy devices. Any disturbance induced onto sense lines is immediately signaled back to the instrument with a direct adverse effect on the output terminals.

To minimize undesired sense line pickup, sense line cables should use the cancelling effects of twisted pair wires.

Shielded twisted pairs are even better, if needed. Sense lines should be physically separated from high current output, ideally via a separate cable. Sense resistors, if used, should be connected as close as practical to the load. Observe the maximum remote sense voltage drop limit (refer to page A-3).

High frequency disturbances are usually minimized by prudent use of 0.01mfd to 1.0 μ fd bypass capacitors.

In high performance applications, as in motor start up and associated inrush/transient currents, extra consideration is required. The cable wire gauge must consider peak voltages and currents which may be up to ten times the average values. An underrated wire gauge adds losses which alter the inrush characteristics of the application and, thus, the expected performance.

The following table identifies popular ratings for DC and AC power source cable wire gauges.

Recommended Wire Gauge Selection Guide Table

Column 1	Column 2	Column 3	Column 4
Size (AWG)	Amperes (Maximum)	Ohms/100 Feet (One Way)	IR Drop/100 Feet* (Col. 2 X Col. 3)
18	5	0.473	2.363
16	7	0.374	2.621
14	15	0.233	3.489
12	20	0.147	2.940
10	30	0.095	2.859
8	40	0.053	2.136
6	55	0.033	1.837
4	70	0.021	1.477
2	95	0.013	1.273

* A maximum of 0.75V is allowable.

The following notes apply to the above table and to the power cable definition:

1. The above figures are based upon insulated copper conductors at 30°C (86°F), two current carrying conductors in the cable plus a safety ground (chassis) plus a shield.

Column 2 and Column 3 in the table above refer to the "one way" ohms and IR drop of current carrying conductors (e.g., a 50-foot cable contains 100 feet of current carrying conductors).

2. Determine which wire gauge to use for the application by knowing the expected peak load current (I_{peak}), the maximum tolerated voltage loss (V_{loss}) within the cable, and the one way cable length. The formula below determines which ohms/100 feet entry is required from Column 3. Read the corresponding wire gauge from Column 1.

$$(\text{Column 3 value}) = \frac{V_{loss}}{I_{peak}} \times 0.02 \times (\text{cable length})$$

Where:

Column 3 value = Entry of the table above

Cable length = One way cable length in feet.

V_{loss} = Maximum loss, in volts, permitted within cable.

Special case: Should the V_{loss} requirement be very loose, the peak may exceed the maximum amperes (Column 2). In this case, the correct wire gauge is selected directly from the first two columns of the table.

Example:

A 20 ampere (I_{peak}) circuit which may have a maximum 0.5 volt drop (V_{loss}) along its 15-foot cable (one way cable length) requires (by formula) a Column 3 resistance value of 0.083. This corresponds to wire gauge size 8 AWG.

If the cable length was 10 feet, the Column 3 value would be 0.125 and the corresponding wire gauge would be 10 AWG.

3. Aluminum wire is not recommended due to soft metal migration at the terminal which may cause long term (years) poor connections and oxidation. If used, increase the wire gauge by two sizes (e.g., specify 10 gauge aluminum instead of 14 gauge copper wire).
4. Derate the above wire gauge (use a heavier gauge) for higher environmental temperatures since conductor resistance increases with temperature.

Temperature in Degrees		Current Capability
C	F	
40	104	80%
50	122	50%

5. Derate the above wire gauge (go to a heavier gauge) for an increased number of current carrying conductors. This offsets the thermal rise of bundled conductors.

<u>Number of Conductors</u>	<u>Current Capability</u>
3 to 6	80%
6	70%

6. The preferred insulation material is application dependent. Elgar's recommendation is any flame retardant, heat resistant, moisture resistant thermoplastic insulation rated to a nominal 75°C (240°F). Voltage breakdown must exceed the combined effects of:

- a) The rated output voltage.
- b) Transient voltages induced onto the conductors from any source.
- c) The differential voltage to other nearby conductors.
- d) Floating or series connections of supplies/loads.
- e) Safety margins to accommodate degradations due to age, mechanical abrasion and insulation migration caused by bending and temperature.

7. Sense lines are generally 24 to 18 (more mechanical strength) gauge wire, twisted pair, shielded, and have the same insulation rating and properties as its related current carrying conductors. Sense lines are physically separated (a separate cable) from current carrying conductors to minimize undesirable pickup.

8. As frequency increases, the magnetic field of the current carrying conductors becomes more significant in terms of adverse coupling to adjacent electrical circuits. The use of twisted pairs help cancel these effects. Shielded twisted pairs are even better. Avoid close coupling with nearby cables by using separate cable runs for high power and low power cables.

9. The above general values and recommendations should be reviewed, modified and amended, as necessary, for each application. Cables should be marked with appropriate safety WARNING decals if hazardous voltages may be present.

APPENDIX B

CONFIGURATION AND

FUNCTIONAL VERIFICATION

CHECKSHEET

Functional Results:

Output Amplitude: _____

Output Frequency: _____

Options: _____

Comments: _____

CONFIGURATION AND FUNCTIONAL VERIFICATION CHECKSHEET

SX SERIES AC POWER SOURCE

Model Number: _____ Chassis S/N: _____

Equipment Property Number: _____

Part of Equipment: _____ Location: _____

Date: _____ Inspector: _____

AC Input Voltage: _____ Output Voltage Range: _____

Oscillator Used: _____

GPIB Compatible: Yes _____ No _____

If yes, GPIB Address: _____

Remote Language: ABLE _____ CIIL _____

Options Installed: (check all that are configured)

Automatic Voltage Range Changing _____

Synchronization _____

Output Current Limit Programming _____

Output Current/Voltage/Power Monitoring via GPIB _____

D-Option (Internal Self Test) _____