

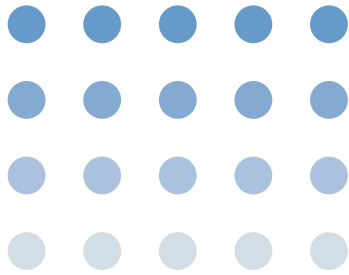

Advanced Test Equipment Rentals
www.atecorp.com 800-404-ATEC (2832)



OPERATION MANUAL

**ELECTRONICS LOAD
PLZ-3W SERIES**

PLZ 153W
PLZ 303W
PLZ 603W
PLZ1003W

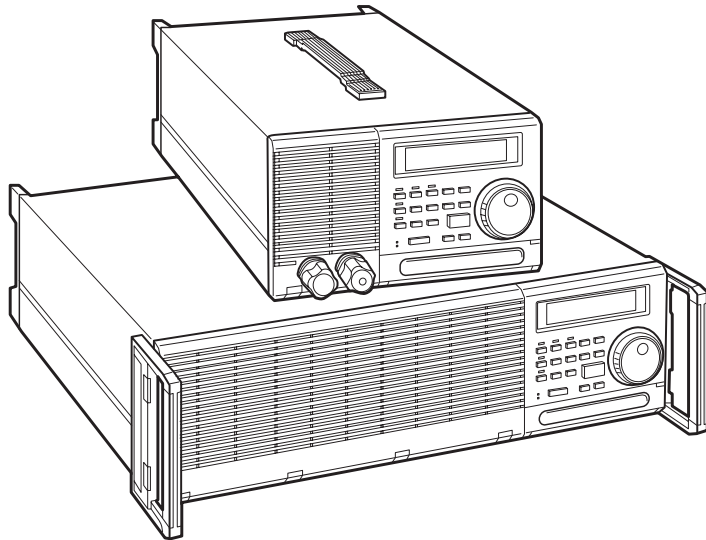

Use of Operation Manual

Please read through and understand this Operation Manual before operating the product. After reading, always keep the manual nearby so that you may refer to it as needed. When moving the product to another location, be sure to bring the manual as well.

If you find any incorrectly arranged or missing pages in this manual, they will be replaced. If the manual it gets lost or soiled, a new copy can be provided for a fee. In either case, please contact Kikusui distributor/agent, and provide the “Kikusui Part No.” given on the cover.

This manual has been prepared with the utmost care; however, if you have any questions, or note any errors or omissions, please contact Kikusui distributor/agent.

Reproduction and reprinting of this product as well as this operation manual, whole or partially, without our permission is prohibited.

Both unit specifications and manual contents are subject to change without notice.

ROM Version Number

This manual is applicable to the Electronic Loads which have the following version of ROM (read only memory).

2.0*
(* denotes 0 to 9.)

When making any inquiries on your Electronic Load, please indicate the following:

- Model No.
- ROM Version No.
- Serial No.

To find the ROM Version No., please refer to Section 2.3 "Power Turn-on Checkout" under Chapter 2.

WARNINGS

and

Caution

Before start using the power supply and during using it, be sure to read and strictly observe the instructions given in the following:

"WARNINGS AND PRECAUTIONS"	Page v
Chapter 2 "PRECAUTIONS AND PREPARATIVE PROCEDURES"	Page 2-1

TABLE OF CONTENTS

	PAGE
WARNINGS AND CAUTIONS	V
RECEIVING INSPECTION	VIII
PACKING FOR RE-SHIPMENT	X
COMPOSITION OF THIS OPERATION MANUAL	XI
Chapter 1. GENERAL	1-1
1.1 Outline	1-2
1.2 Features	1-3
Chapter 2. PRECAUTIONS AND PREPARATIVE PROCEDURES	2-1
2.1 Installation	2-2
2.1.1 Environments	2-2
2.1.2 Precautions for Moving the Electronic Load	2-4
2.2 Connecting the AC Input Power Cable	2-5
2.2.1 Checking the AC Line Voltage Setting	2-5
2.2.2 Changing the AC Line Voltage Setting and Fuse	2-5
2.2.3 Connecting the AC Input Power Cable	2-6
2.3 Power Turn-on Checkout	2-7
2.4 Load Wiring	2-10
2.4.1 Load Wiring and Protection Features	2-10
2.4.2 Inductance of Load Wiring	2-12
2.4.3 Remote Sensing	2-13
2.5 To Prevent Oscillation	2-14
Chapter 3. OPERATING METHOD	3-1
3.1 Description of Front and Rear Panels	3-3
3.2 Initial Display When Power-on	3-4
3.3 Basic Rules of Panel Operation	3-5
3.4 C.C Mode, C.R Mode, C.V Mode, and C.P Mode of Operation	3-6
3.5 Basic Operating Method	3-12
3.5.1 C.C Mode of Operation	3-12
3.5.2 C.R Mode of Operation	3-18
3.5.3 C.V Mode of Operation	3-21
3.5.4 C.P Mode of Operation	3-23
3.5.5 Memory Function	3-24
3.5.6 Switching Function	3-28
3.5.7 Keylock Function	3-30
3.5.8 Setup Resume Function and Backed-up Memory	3-31
3.5.9 Configuration	3-34
3.5.10 Alarm Function	3-36
3.5.11 Short Function	3-37
3.6 Sequence Operation	3-39
3.6.1 Description of Sequence Operation	3-40
3.6.2 Outline of Settings for Sequence Operation	3-47
3.6.3 Sequence Operation Procedure	3-48
3.7 External Control (Remote Control)	3-60
3.7.1 Analog Remote Control of C.C mode	3-61

3.7.2	Analog Remote Control of C.R mode	3-63
3.7.3	Analog Remote Control of C.P mode	3-65
3.7.4	Remote Control of Load ON/OFF	3-66
3.7.5	Remote Control of Range Select	3-68
3.7.6	Trigger Signals	3-69
3.8	Master/Slave Parallel Operation	3-71
Chapter 4.	REMOTE PROGRAMMING	4-1
4.1	Initial Setting of Interface	4-4
4.1.1	GPIB Interface	4-4
4.1.2	RS-232C Interface	4-4
4.1.3	MCB Interface	4-5
4.2	Programming Format	4-6
4.2.1	Commands	4-6
4.2.2	Response Message	4-7
4.2.3	Acknowledge Message (RS-232C)	4-7
4.2.4	Flow Control (RS-232C)	4-8
4.3	Description of Commands	4-9
4.3.1	Terminology	4-9
4.3.2	Structures of Commands	4-10
4.4	Bit Assignment of Status Registers	4-28
4.5	SRQ, Status Bytes, and Registers	4-31
4.6	Table of Error Codes	4-32
4.7	Examples of Remote Programming	4-33
4.7.1	Initializing the Interface Board	4-33
4.7.2	Examples of Application Programs	4-33
4.7.3	Table of Command Headers	4-38
Chapter 5.	PANEL DESCRIPTION	5-1
5.1	Front Panel	5-2
5.2	Rear Panel	5-8
Chapter 6.	MAINTENANCE AND CALIBRATION	6-1
6.1	Maintenance and Inspection	6-2
6.1.1	Cleaning the Front Panel	6-2
6.1.2	Cleaning the Dust Filter	6-2
6.1.3	Inspecting the AC Input Power Cable	6-3
6.1.4	Performance Test	6-3
6.1.5	Overhaul	6-4
6.2	Calibration	6-5
6.2.1	Preparation	6-5
6.2.2	Calibration Instruments	6-5
6.2.3	Calibration Setup	6-5
6.2.4	Calibration Mode Entry Procedure	6-6
6.2.5	Calibration Procedure	6-7
6.3	Before Ordering Repair Service	6-11
Chapter 7.	SPECIFICATIONS	7-1
7.1	Electrical Specifications	7-2
7.2	Dimensions and Weights	7-8
7.3	Accessories	7-9
7.4	Optional Items	7-11

TABLE OF CONTENTS

APPENDICES	A-1
Appendix 1. Table of Error Messages	A-2
Appendix 2. Sequence Coding Sheets	A-6
Appendix 3. Table of Functions	A-9
INDEX	I-1

WARNINGS AND CAUTIONS

Although the Electronic Load is incorporated with various protection features, you must handle it very carefully in order to prevent electric shock hazards to yourselves and to avoid damage to the equipment. Strictly observe the **WARNINGS** and **Caution** given below.

WARNINGS

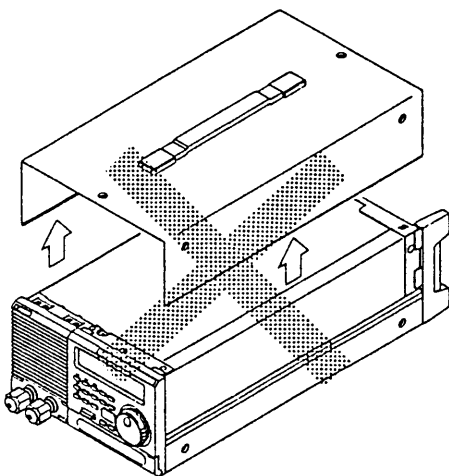
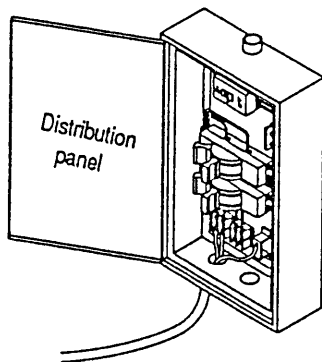
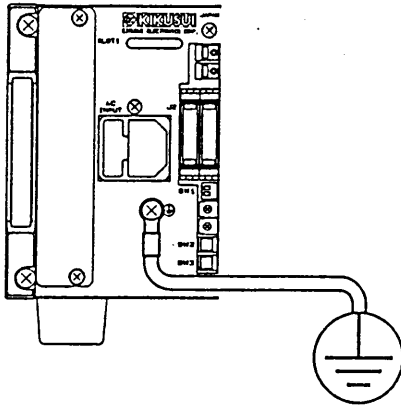

- Be sure to ground the Electronic Load
 - In order to prevent electric shock hazards, ground the Electronic Load by directly connecting the ground terminal ⊕ of the Electronic Load to an earth line or by connecting the GND wire (green) of the AC input power cable (that accompanies the Electronic Load) to an earth line.
 - Grounding must be done to an earth line of Class 3 or better, of Electric Installation Ordinances (or to meet an equivalent local Electrical Equipment Regulations applicable in your area).
 - If you neglect grounding the Electronic Load or if the grounding line is made open, serious electric shock hazards can result.

- Be aware of the danger the AC power cable connection
 - The AC input power cable connection task involves danger. The task must be undertaken only by qualified personnel.
 - Before handling the AC input power cable or moving the Electronic Load, be certain that the cable has been disconnected from the AC power source.

- Do not touch the internal components.
 - Do not touch the internal components of the Electronic Load. Do not open the casing of the Electronic Load.

WARNINGS

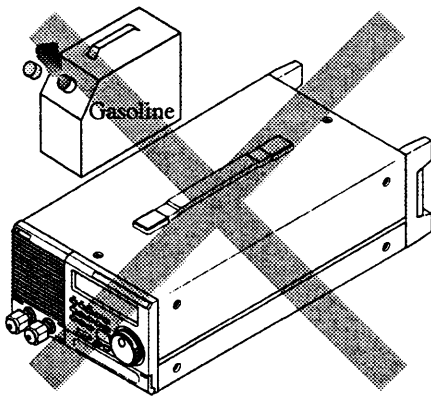

- Do not use the Electronic Load in an explosive atmosphere.
- Do not operate the Electronic Load in a flammable, explosive, or otherwise hazardous atmosphere.

Caution

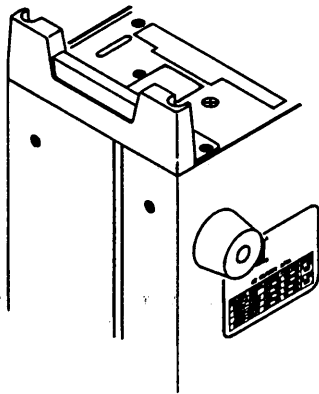

AC50/60Hz MAX70VA

VOLTAGE SELECT	SWITCH POSITION	FUSE
90V - 110V	A <input type="checkbox"/> B <input type="checkbox"/> C <input type="checkbox"/> D <input type="checkbox"/>	AC250V
100V - 132V	A <input type="checkbox"/> B <input type="checkbox"/> C <input type="checkbox"/> D <input type="checkbox"/>	1.5A SB
180V - 220V	A <input type="checkbox"/> B <input type="checkbox"/> C <input type="checkbox"/> D <input type="checkbox"/>	AC250V
210V - 250V	A <input type="checkbox"/> B <input type="checkbox"/> C <input type="checkbox"/> D <input type="checkbox"/>	1A (T)

- Operate the Electronic Load on a correct AC power source.
- Be certain that the AC input voltage and frequency are within the specified ranges. (The AC line requirements are shown on the bottom of the Electronic Load.)

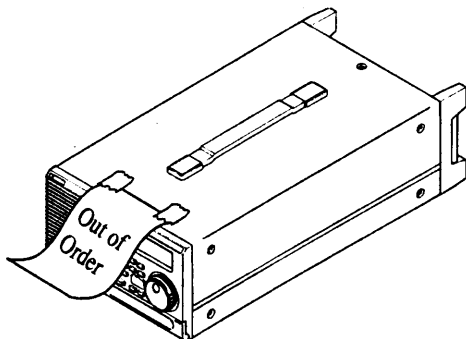

- Do not use a failed Electronic Load.
- When the Electronic Load has failed or has become malfunctioning, immediately stop using it and disconnect its AC input power cable from the AC power source—the AC line outlet or the AC power distribution panel.
- Indicate clearly on the Electronic Load that it is out of order and must not be used.

DANGER SIGNS AND SYMBOLS INDICATED ON THE ELECTRONIC LOAD

The signs and symbols put on the Electronic Load, for the sake of safety, are as follows.

- WARNING** Sign for possible electric shock hazard
- This sign warns you that the place involves a danger—a matter of electric shock hazard to the personnel and damage to the equipment.
 - When handling the matter related to the place, be sure to observe strictly the instructions given in the text of this manual. Unless you strictly observe the instructions, you will be exposing yourself to a danger of electric shock hazard.
 - Until you fully understand the matters related to the WARNING and are certain that all of the required safety conditions are met, do not proceed to further steps of the operation procedure.

- CAUTION** Sign for possible damage
- This sign alerts you to that the place involves a matter which can lead to damage to the Electronic Load and/or the devices connected to it.
 - When handling the matter related to the place, be sure to observe strictly the instructions given in the text of this manual. Unless you strictly observe the instructions, the Electronic Load and/or the devices connected to it may be damaged.
 - Until you fully understand the matters related to the WARNING and are certain that all of the required safety conditions are met, do not proceed to further steps of the operation procedure.



- Mark to refer to operation manual
- This mark requests you to refer to the corresponding section of the operation manual.



Ground terminal

DANGER SIGNS AND SYMBOLS INDICATED IN THIS MANUAL

The signs and symbols indicated in this operation manual, for the sake of safety, are as follows.

WARNINGS

A matter which can lead to electric shock hazards.

Caution

A matter which can lead to damage to the Electronic load and/or to the devices connected to it.

NOTE

Supplemental information.

Receiving Inspection

Upon receipt of the Electronic Load, please immediately unpack and inspect it for damage which might have occurred during transportation. Also check that the accessories are present.

NOTE Do not discard the packing materials if you foresee re-shipping of the Electronic Load.

The Electronic Load and its accessories delivered to you should be as follows:

Packed states of Electronic Loads

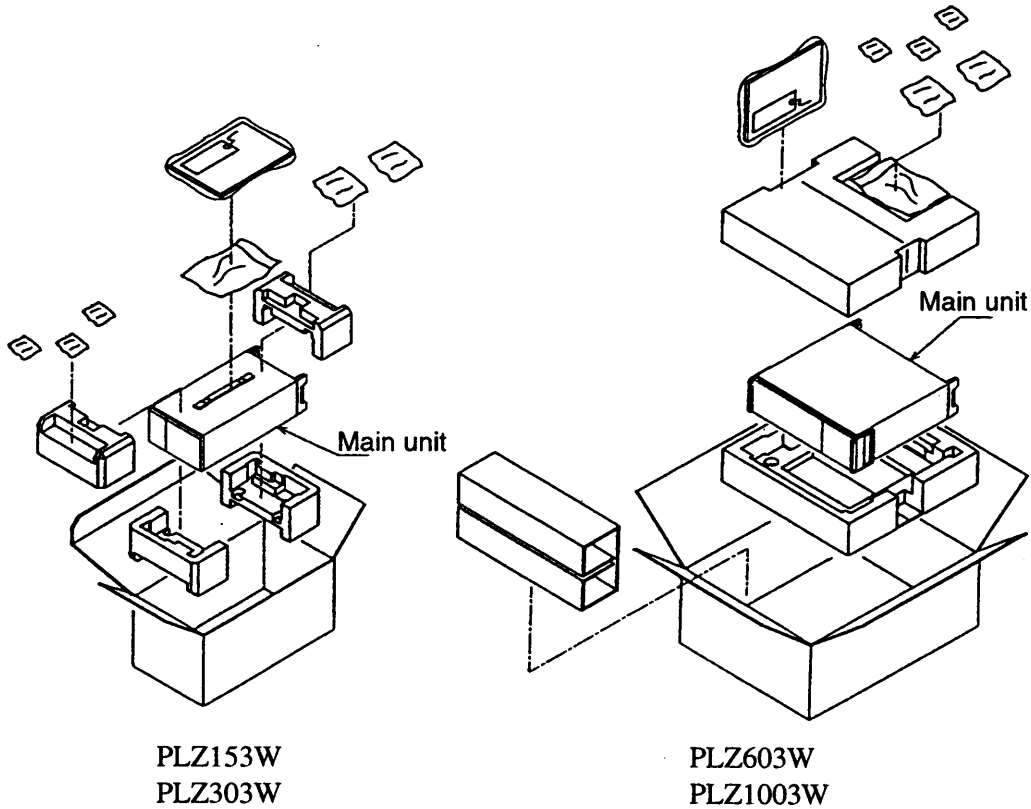

Accessories

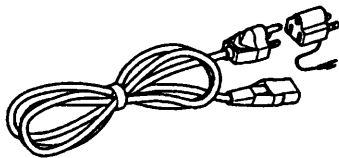

① AC input power cable (1 ea.)
(with 3P-2P adaptor)

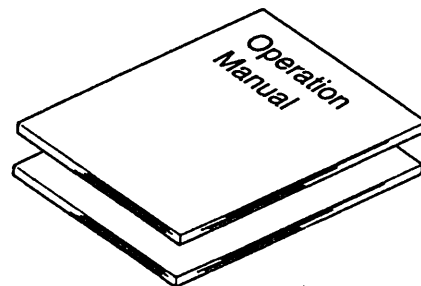

② Instruction manual (1 copy)
Sequence operation guide book (1 copy)

NOTE • The 3P-2P adaptor is only for domestic models (models to be used in Japan)

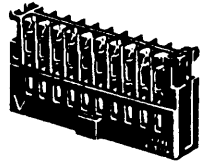

③ External control connectors (2 pcs)



④ External control connector covers (4 pcs)

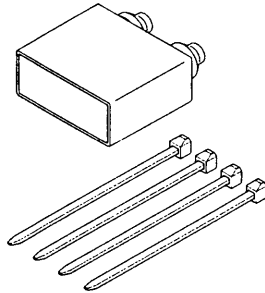

⑤ Load terminal (DC input) covers (1 pcs)

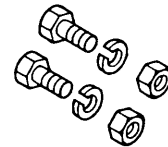

⑥ Load terminal connection bolts, nuts, and spring washers
(2 pcs for each of the items)
M6-14 (PLZ153W, PLZ303W)
M8-18 (PLZ603W, PLZ1003W)

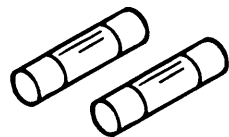

⑦ Spare fuses (2 pcs)

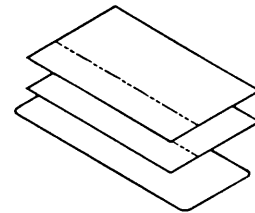

⑧ Seals (3 sheets)

The fuses which accompany the Electronic Loads are as follows:
(Fuse voltage rating : 250VAC)

	Load shipped for nominal 100V		Load shipped for nominal 200V	
	Installed in AC inlet, 100V	Supplied separately, 200V	Installed in AC inlet, 200V	Supplied separately, 100V
PLZ153W	1.5A (SB) 1 pc.	1A (T) 2 pcs	1A (T) 1 pc.	1.5A (SB) 2 pcs
PLZ303W	1.5A (SB) 1 pc.	1A (T) 2 pcs	1A (T) 1 pc.	1.5A (SB) 2 pcs
PLZ603W	2A (SB) 1 pc.	1.6A (T) 2 pcs	1.6A (T) 1 pc.	2A (SB) 2 pcs
PLZ1003W	3A (SB) 1 pc.	1.6A (T) 2 pcs	1.6A (T) 1 pc.	3A (SB) 2 pcs

PACKING FOR RE-SHIPMENT

To re-ship the Electronic Load, use the packing materials in which the Electronic Load was delivered to you. (If you have discarded the packing materials, order your Kikusui agent for new ones.) For the packing method, refer to the illustration on a preceding page.

NOTE

- *When packing the Electronic Load, disconnect the AC input power cable, load cables, and external control connectors.*

COMPOSITION OF THIS OPERATION MANUAL

This operation manual is composed of seven chapters and appendices as follows:

Chapter 1. GENERAL

Introduces an overview and features of the Electronic Load.

Chapter 2. PRECAUTIONS AND PREPARATIVE PROCEDURES

Elaborates procedures for operation, AC input power cable connection, power-on check, load connection, and other preparative matters.

Chapter 3. OPERATING METHOD

The former half of this chapter introduces the names of keys, indicators and other panel items, and describes the basic operation method of the Electronic Load; the latter half describes procedures for sequence operation and other applied types of operation.

Chapter 4. REMOTE PROGRAMMING

Elaborates the method to remote-control the Electronic Load via an interface board (optional) from an external device.

Chapter 5. PANEL DESCRIPTION

Introduces the names of and describes the functions of the switches and other items of the front and rear panels.

Chapter 6. MAINTENANCE AND CALIBRATION

Elaborates the maintenance, inspection, and calibration methods.

Chapter 7. SPECIFICATIONS

Gives tables of electrical specifications, mechanical specifications, accessories, and optional items.

APPENDICES

Provide an error message table, sequence coding sheets and entry examples, and a table of functions enabled or disabled.

Chapter 1

GENERAL

This chapter introduces an outline and features of the Electronic Load.

Contents	Page
1.1 Outline	1-2
1.2 Features	1-3

1.1 Outline

The PLZ-3W Series Electronic Loads are featured by performance reliability and safety. Each Electronic Load incorporates a current control circuit and renders highly stable operation and rapid response. It is a microprocessor-based instrument and provides advanced functions and ease of operation.

The Electronic Load can be remote-controlled via a GPIB, RS-232C, or MCB (Multi-channel Bus) interface (optional), thereby making them applicable to various purposes. Typical applications are for research systems in laboratories and on production and inspection lines in manufacturing plants.

As the Electronic Load has a constant-power control function, it can be used especially efficiently for battery test. It can be used also to simulate a load of rapid response.

1.2 Features

The Electronic Load is incorporated or can be optionally incorporated with the various advantageous features as follows:

■ Constant power mode

The Electronic Load is incorporated with a constant power (CP) mode, in addition to the constant current (CC), constant resistance (CR), and constant voltage (CV) modes. The constant power mode is especially advantageous for battery life tests.

■ Rapid response (50 μ s)

When in the CC mode, the current rises up or falls down rapidly (50 μ s). This feature allows to evaluate accurately the transient response characteristics of DC power supplies. With this feature, the Electronic Load serves as an accurate simulated load which draws the current in an accurate waveform.

■ Sequence operation

You can enter sequence operation patterns locally from the front panel or remotely from a personal computer via GPIB or other interface bus, and store the patterns on the internal memory. The stored patterns can be recalled and executed locally at the front panel or remotely from the computer or with a trigger signal.

Sequence operation can be programmed in either one of the following two types:

- (a) Fast speed sequence: You can program sequences with minimum 100 μ s per step.
- (b) Normal speed sequence: You can program sequences with a ramp waveform per step.

■ Ease of operation

You can select each of the major functions by pressing the corresponding key (one-key one-function select system). You can finely adjust the setting value with the JOG/SHUTTLE dials. You can enter values with the numeric entry keys by using the RC11 (optional). You can remote-control the Electronic Load by using the RC02-PLZ Remote Controller (optional).

By using the setup function, you can save the values of various settings and recall them as you need them. By using the **[A]** , **[B]** and **[C]** keys, you can save the settings of each operation mode in memory and recall them as you need them. This features is very convenient when the same tests are to be repeated.

■ A backlight LCD

The Electronic Load has a backlighted-type LCD (liquid crystal display) which displays data, which can be easily read being less affected by room illumination.

■ Various interface boards (optional)

The Electronic Load can be controlled over a GPIB, RS-232C, or MCB interface bus. This feature, as combined with the programmed sequence control function, allows you a high flexibility of system configuration.

The MCB is a unique interface developed by Kikusui. It allows you to control up-to-fifteen instruments (electronic load devices and power supplies) in an on-line mode via a standard interface system (GPIB or RS-232C).

Chapter 2

PRECAUTIONS AND PREPARATIVE PROCEDURES

This chapter gives you information on precautions you must observe and preparative procedures you must follow before start operating the Electronic Load.

Contents	Page
2.1 Installation	2-2
2.1.1 Environments	2-2
2.1.2 Precautions for Moving the Electronic Load....	2-4
2.2 Connecting the AC Input Power Cable	2-5
2.2.1 Checking the AC Line Voltage Setting	2-5
2.2.2 Changing the AC Line Voltage Setting and Fuse	2-5
2.2.3 Connecting the AC Input Power Cable	2-6
2.3 Power Turn-on Checkout	2-7
2.4 Load Wiring	2-10
2.4.1 Load Wiring and Protection Features	2-10
2.4.2 Inductance of Load Wiring	2-12
2.4.3 Remote Sensing	2-13
2.5 To Prevent Oscillation	2-14

2.1 Installation

2.1.1 Environments

Avoid using the Electronic Load in adverse or hazardous environments as mentioned below.

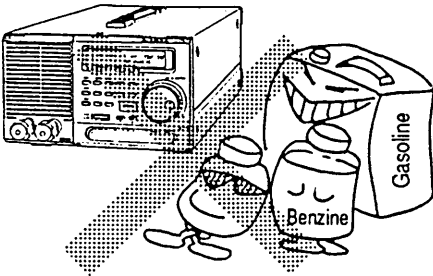

(a) Flammable atmosphere

Do not use the Electronic Load in flammable or explosive atmosphere, to prevent fire and explosion hazards.

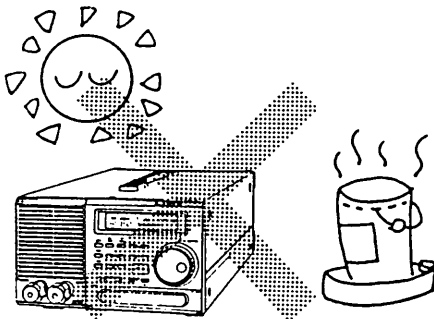

(b) High temperature

Do not expose the Electronic Load to a source of heat, such as direct sunlight (near a window), a space heater, etc. Avoid a place where temperature may change rapidly. (The temperature range for the guaranteed performance is 0 to 40°C or 32 to 104°F.)

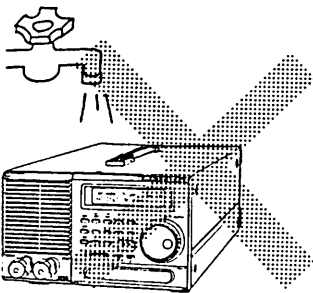

(c) High humidity

Do not expose the Electronic Load to high humidity—do not place it near a water heater, a humidifier, a water faucet, or a bath. (The humidity range for the guaranteed performance is 30 to 80% RH.)

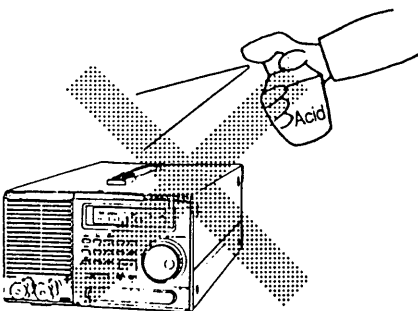

(d) Corrosive atmosphere

Do not expose the Electronic Load to corrosive atmosphere—such as of sulfuric acid mist.

(e) Dusty place

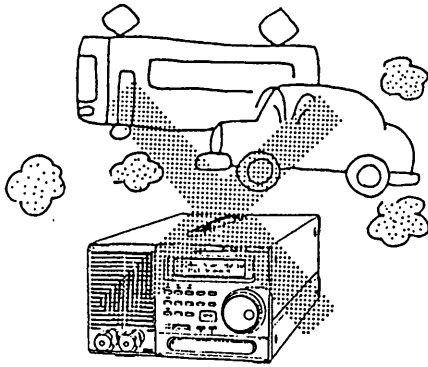

(f) Blocked ventilation air flow

Do not block the louvers of the Electronic Load. Provide an ample space (30 cm or more) behind the rear panel of the Electronic Load.

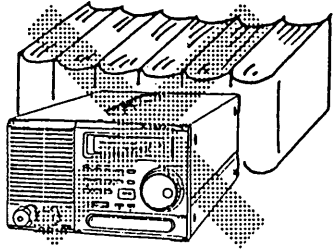

(g) Unstable position

Do not put the Electronic Load in a swaying, slanted, or otherwise unstable position.

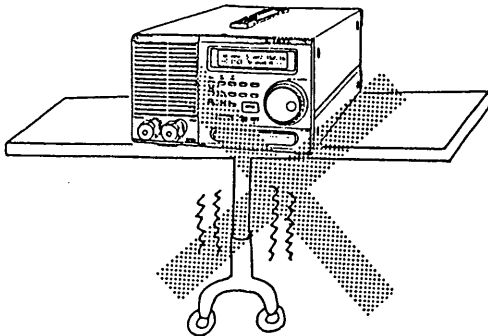

(h) Strong electric or magnetic field

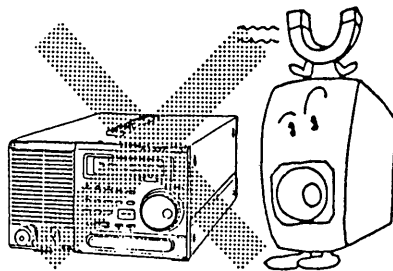

2.1.2 Precautions for Moving the Electronic Load

WARNINGS

- *Be sure to disconnect the AC input power cable from its power source before moving the Electronic Load.*

■ How to Use the Handles

- ① Slide the two lock switches simultaneously in the "UNLOCK" direction, and the handles will become movable.
- ② Fully pull-out (or push-in) the handles until they click.

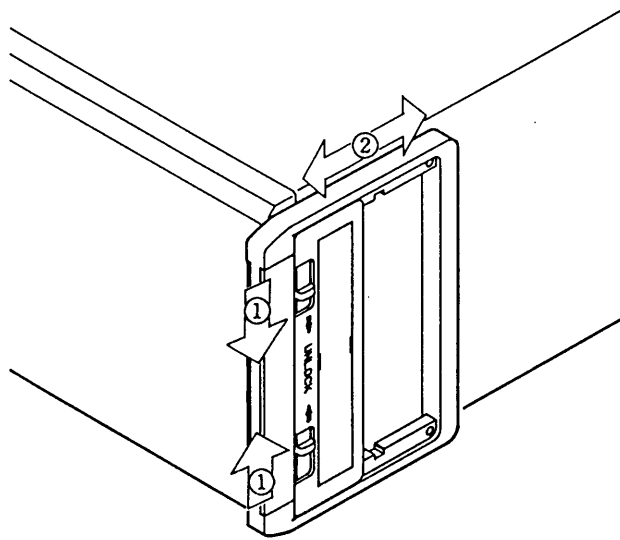

Figure 2.1-1

2.2 Connecting the AC Input Power Cable

2.2.1 Checking the AC Line Voltage Setting

Before connecting the Electronic Load to an AC line, check that the AC line voltage selector switches on the bottom panel of the Electronic Load are set in the correct positions for the AC line voltage.

Caution

- If the AC line voltage is incorrect (that is, if the AC line voltage selector switches are not set in the correct positions), the Electronic Load may not operate properly and may be damaged (burned).

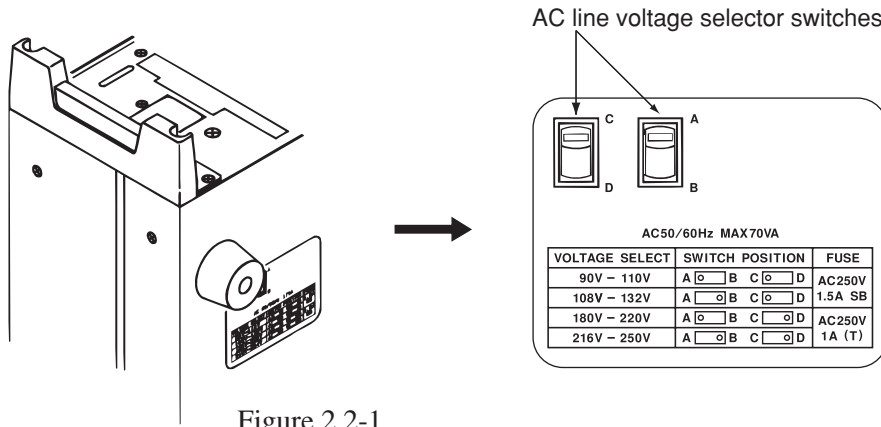

Figure 2.2-1

2.2.2 Changing the AC Line Voltage Setting and Fuse

If the switches are not in the correct positions, change them to the correct positions (and change the fuse also as required). See the table on the bottom of the Electronic Load (table in Figure 2.2.1) for the AC line voltages, switch positions, and fuse ratings.

WARNINGS

- Never connect the AC input power cable until the AC line voltage setting is correctly done.
- Never use a fuse of an incorrect rating. Never use a copper wire or other conductor wire to short the fuse terminals.

Caution

- Be sure to use a fuse of the correct type and rating.

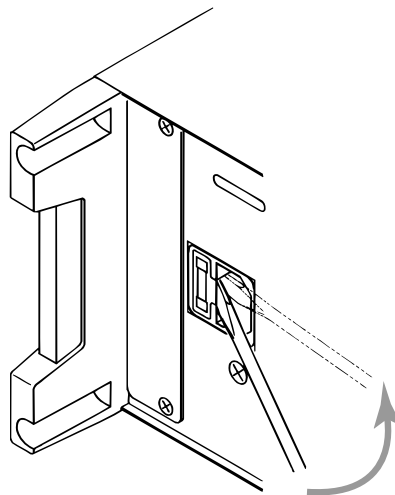

Figure 2.2-1

2.2.3 Connecting the AC Input Power Cable

The AC input power cable that is provided varies depending on the destination for the product at the factory-shipment.

WARNINGS

- *The AC input power cable for 100 V system shown in Figure 2.2-3 has a rated voltage of 125 VAC. If this power cable is used at the line voltage of a 200 V system, replace the power cable with that satisfying that line voltage. Appropriate power cable must be selected by qualified personnel (those who have electrical knowledge). If such a power cable cannot be obtained, contact your Kikusui distributor/agent.*

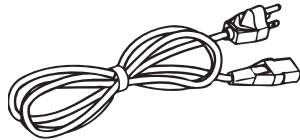

Power cable for 100 V system [85-AA-0004]
Rated voltage: 125 VAC
Rated current: 10 A

Figure 2.2-3 AC input power cable for 100 V system

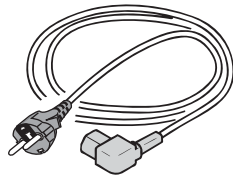

Power cable for 200 V system [85-AA-0005]
Rated voltage: 250 VAC
Rated current: 10 A

Figure 2.2-4 AC input power cable for 200 V system

Do not use the power cable attached to this product for the power cable of other instruments.

To connect the AC input power cable, proceed as follows:

- Check that the POWER switch of the Electronic Load is turned off.
- Connect the power cable to the AC inlet on the rear panel.
Use the provided power cable or power cable that is selected by qualified personnel.
- Plug the power cable into the receptacle.

Grounding

WARNINGS

- *Not grounding the Electronic Load creates danger of electric shock.*
- *Connect the ground terminal to an electrical ground (safety ground).*

Caution

- *Not performing adequate grounding work on the Electronic Load results in malfunction or the production of large noises from the Electronic Load.*

- Ground the Electronic Load by connecting the GND wire (green wire) of the AC input power cable or the GND  terminal to an earth line.

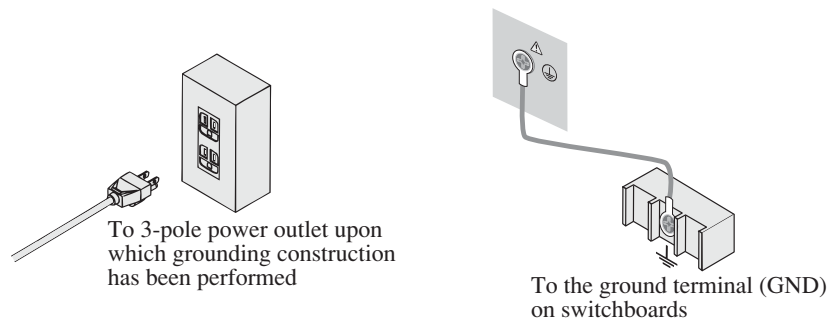

Figure 2.2-5

2.3 Power Turn-on Checkout

Perform power-on checkout of the Electronic Load as follows:

■ Power-on Check Procedure

① Make certain that the POWER switch is OFF.



② Make certain that the instrument-side end of the AC input power cable is connected to the Electronic Load.



③ Connect the power-source-side end of the AC input power cable to an AC line receptacle or power distribution panel.



Caution

• Make certain that the AC line voltage and frequency are within the specified ranges.

④ Turn-on the AC power switch of the Electronic Load.

⑤ Check that the indications on the display are normal.

• Normal indications (examples)

```

PLZ 153W    30A    150W
I/F None
  
```

▼ At about 2 seconds later

```

PLZ 153W    30A    150W
Ver 1.00
  
```

• The bottom row indicates the ROM Version Number

▼ At about 2 seconds later

```

0.00A    0.00V    0.0W
-- ISET    0.00A H --
  
```

• Abnormal Indications

If one of the indications given in the below table appears, the Electronic Load is abnormal. If this is the case, follow the instructions given on the right hand side in the below table. If the abnormality is not remedied still, order your Kikusui agent for repair.

■ **The display screen backlight does not illuminate and nothing appears on the screen.**

(Nothing appears.)

- Make certain that the AC input power cable is connected correctly. Then turn-on the POWER switch again.

■ **Although the display screen backlight illuminates, nothing appears on the screen.**

(Nothing appears.)

- Adjust the CONTRAST control (varies depending on temperature). Then turn-on the POWER switch again.

■ **Although a cursor appears, no characters appear.**

■

- If the interface board (optional) has been installed, remove it and then turn-on the POWER switch again. If the display is remedied by this procedure, install the interface board and then turn-on the POWER switch.

■ **The output voltage or current value indicated on the display is abnormal.**

13.54A 5.27V 71.4W
 -- ISET 0.00A H --

- (This is an example.)
- Turn-on the POWER switch again.

■ **An error message appears.**

RAM Data Error

- (This is an example.)
- Refer to Appendix 1 "Table of Error Messages" and take the actions as required. Then turn-on the POWER switch again.



⑥ Press the **[I SET]** key to enable setting in the constant current mode.



⑦ Press the **[LOAD]** key and check that the lamp above the key illuminates.



⑧ Press the **【LOAD】** key again and check that the lamp above the key goes out.



⑨ Turn OFF the POWER switch.

- The turn-on checkout procedure is complete by the above.

2.4 Load Wiring

For efficient and stable use of the Electronic Load, make correct wiring for the Electronic Load.

2.4.1 Load Wiring and Protection Features

[1] Load Wiring Procedure

- 1) Turn OFF the POWER switch of the Electronic Load.
- 2) Check that the output voltage of the equipment to be test is not higher than 120 V DC.

Caution • The maximum allowable input voltage of the Electronic Load is 120 V DC.

- 3) Check that the output voltage of the equipment to be test is 0 V (zero volts).
- 4) Connect the Electronic Load to the equipment to be tested, using wires of sufficiently large gauge and paying attention to that the polarity is correct. Refer also to [2], [3] and [4] for correct connections.

WARNINGS • Do not touch the terminals of the Electronic Load inadvertently. When in test, a voltage is applied to the terminals of the Electronic Load. To avoid electric shock hazards, be certain before touching them that no voltage is applied to the terminals.

Caution • Be sure to use the load terminal covers for electrical connection. Pass the wires through the covers and then connect them to the load terminals.
• Be sure to connect the load wires by using press-connection terminals and fix the terminals securely to the load terminals by using the screws which accompany the Electronic Load.

- 5) When connecting load wires to the load terminals on the PLZ153W or PLZ303W front panel, put the front-panel load terminal covers hiding crimped terminals of the load wires. (See Figure 2.4-1.)

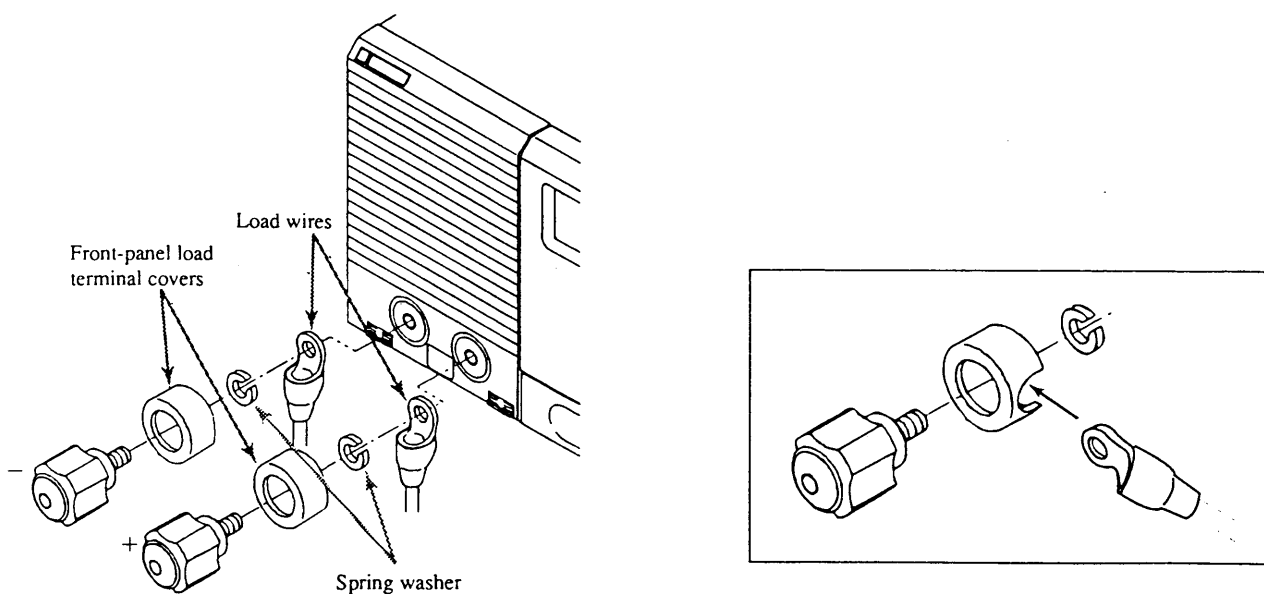

Figure 2.4-1

[2] Polarity

Connect the positive (+) terminal of the Electronic Load to that of the equipment to be tested and the negative (–) terminal of the Electronic Load to that of the equipment to be tested. If you connect the wires in the wrong polarity, the buzzer will sound and the following message will appear on the display. (The buzzer will sound when a reverse voltage of 0.3 V or more is applied to the Electronic Load.)

```

0 . 0 0 A   0 . 0 0 V   0 . 0 W
--  * A L A R M *   R E V E R S E

```

When the above state has occurred, immediately turn OFF the POWER switch of the equipment to be tested.

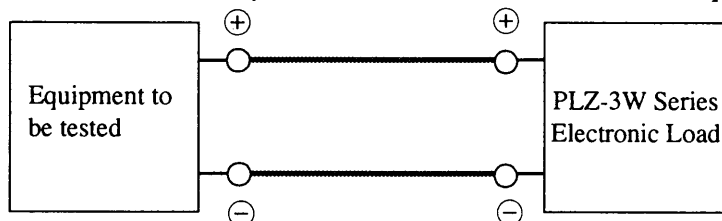

Figure 2.4-2

Caution

- If you connect the Electronic Load in the wrong polarity, it may draw an abnormal current and may be damaged.

[3] Wire Gauges

Be sure to use wires of sufficiently large gauges. If the wire resistances are large, large voltage drops will occur in the wires and the voltage at the Electronic Load may become less than its minimum operable voltage (1.5 V).

Caution

- For the load wiring, use sufficiently large wires of non-flammable heavy-cover type.

NOTE

- Amperage of copper wires (soft-copper wires, at 20 °C)

Wire gauges (nominal cross section areas) and amperage (current rating) recommended by Kikusui are as shown in Table 2.4-1.

Table 2.4-1

Gauge (cross section)	Amperage
8 mm ²	30 A
14 mm ²	50 A
22 mm ²	80 A
38 mm ²	100 A
60 mm ²	150 A
80 mm ²	200 A

NOTE

- Sizes of terminal bolts of Electronic Load

The sizes of the terminal bolts of the Electronic Loads are as shown in Table 2.4-2.

Table 2.4-2

	PLZ153W	PLZ303W	PLZ603W	PLZ1003W
Front panel	M 6	M 6	—————	—————
Rear Panel	M 6	M 6	M 8	M 8

[4] Overvoltage

WARNINGS

- The maximum allowable input voltage of the Electronic Load is 120 V DC. If you apply a voltage higher than this, the Electronic Load may be damaged. As the Electronic Load detects an overvoltage, it will sound an alarm buzzer and will indicate the following message on the display and will become the load off state. When this state has occurred, immediately lower the input voltage of the Electronic Load.

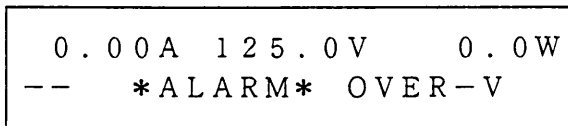

2.4.2 Inductance of Load Wiring

If the load wiring distance is long or the wiring loops are large, the wiring will exhibit a large inductance. The large inductance will cause a large inductive voltage drop in the load wiring, resulting in a state that the voltage at the Electronic Load becomes less than the minimum operable voltage (1.5 V) and the current waveform is disturbed or that, due to current phase lag, control of the Electronic Load becomes unstable and the test setup oscillates. To minimize the load wiring inductance, make the wiring distance as short as possible and strand the load wires to small loops.

The above is especially true when the Electronic Load is to be operated with rapid rise up and fall down current. When this is the case, it is essential to make the wiring distance short.

When operating the Electronic Load in a DC-wise mode only, oscillation can be suppressed by connecting between the input terminals of the Electronic Load a capacitor and a resistor connected in series as shown in Figure 2.4-2. When doing this, however, you must pay attention to the ripple current of the capacitor.

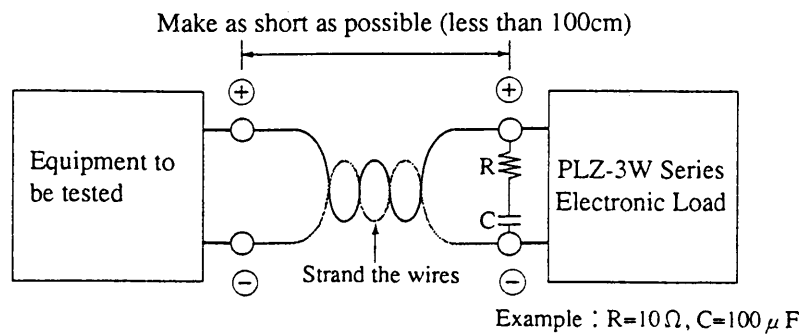

Figure 2.4-3

2.4.3 Remote Sensing

The Electronic Load provides a remote sensing function for accurate setting of resistance, voltage or current by compensating for the voltage drop in the load wiring. You are recommended to use the remote sensing function also to stabilize the operation of the Electronic Load, especially to improve the transient response performance when in the CR or CP mode.

■ Wiring for remote sensing

For remote sensing, connect the +S and -S terminals on the rear panel of the Electronic Load to the "+" and "-" terminals of the equipment to be tested.

NOTE

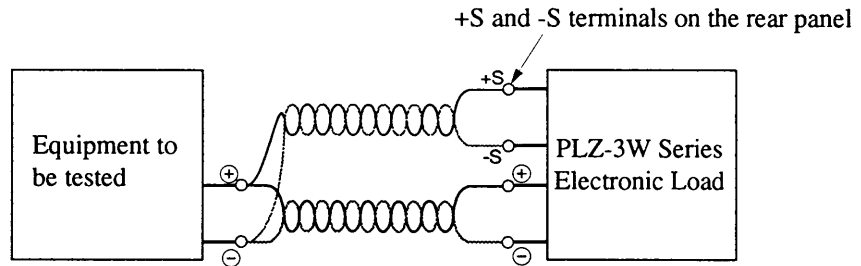

Figure 2.4-4

■ To connect wires to +S and -S terminals

Strip back the insulation of the sensing wires. Pressing the "A" position in Figure 2.4-5 with a screwdriver, insert the stripped end of each sensing wire into the corresponding terminal.

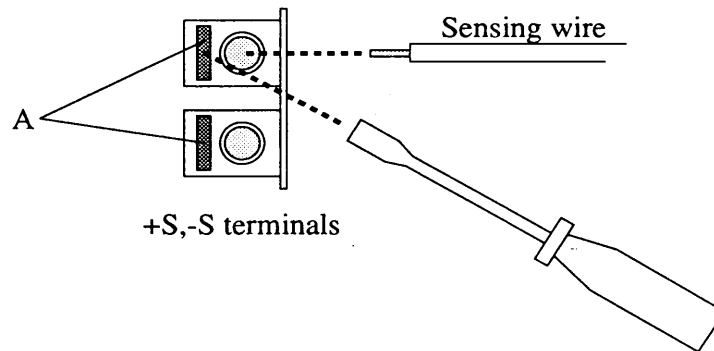

Figure 2.4-5

2.5 To Prevent Oscillation

The frequency response characteristics of the Electronic Load are as shown in Figures 2.5-1 and 2.5-2. At higher frequencies, the Electronic Load becomes inductive. If the equipment connected to the Electronic Load also is inductive, the test setup may oscillate due to phase rotation. To prevent oscillation, the equipment connected to the Electronic Load should be capacitive.

When operating the Electronic Load in a DC-wise mode only, oscillation can be suppressed by connecting between the input terminals of the Electronic Load a capacitor and a resistor connected in series. When doing this, however, you must pay attention to the ripple current of the capacitor.

NOTE

The frequency response characteristics of the Electronic Load, for an AC component superimposed on the DC input current, are as shown below.

■ **Frequency response when in C.C mode**

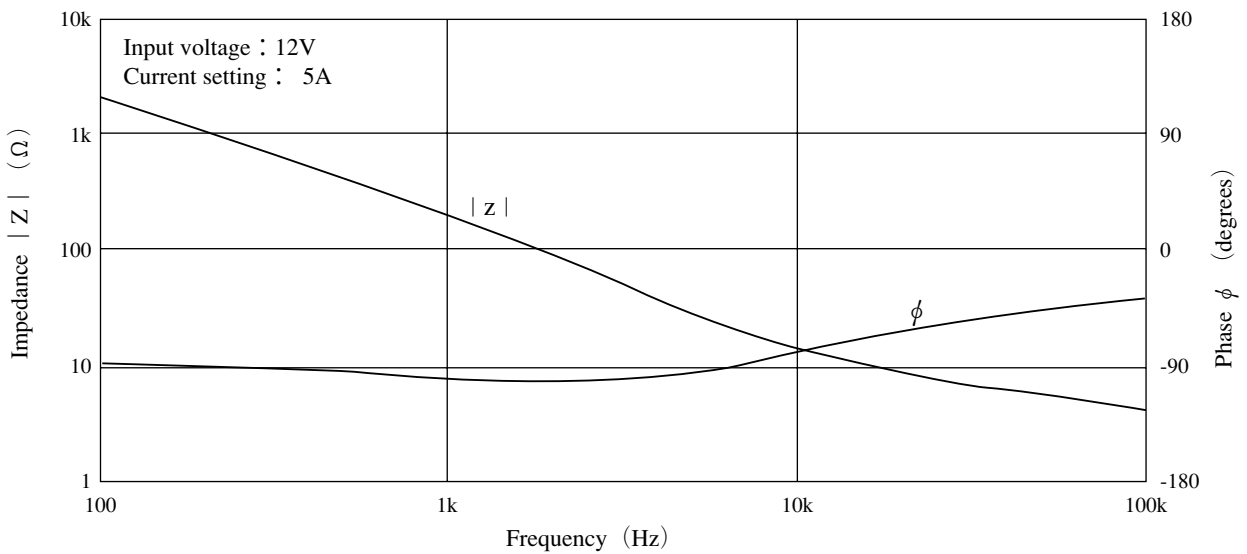

Figure 2.5-1

■ **Frequency response when in C.R mode**

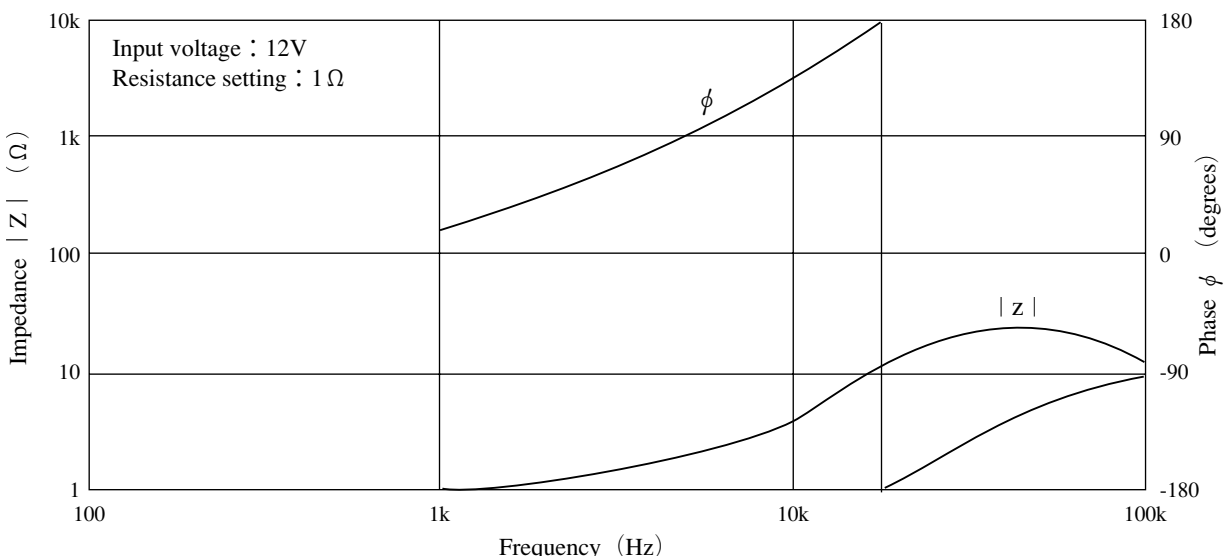

Figure 2.5-2

Chapter 3

OPERATING METHOD

The former half of this chapter introduces the names of keys, indicators and other panel items, and the basic operating methods of the Electronic Load; the latter half describes procedures for sequence operation and other applied types of operation.

Contents	Page
3.1 Description of Front and Rear Panels	3-3
3.2 Initial Display When Power-on	3-4
3.3 Basic Rules of Panel Operation	3-5
3.4 C.C Mode, C.R Mode, C.V Mode, and C.P Mode of Operation	3-6
3.5 Basic Operation Method	3-12
3.5.1 C.C Mode of Operation	3-12
3.5.2 C.R Mode of Operation	3-18
3.5.3 C.V Mode of Operation	3-21
3.5.4 C.P Mode of Operation	3-23
3.5.5 Memory Function	3-24
3.5.6 Switching Function	3-28
3.5.7 Keylock Function	3-30
3.5.8 Setup Resume Function and Backed-up Memory	3-31
3.5.9 Configuration	3-34
3.5.10 Alarm Function	3-36
3.5.11 Short Function	3-37
3.6 Sequence Operation	3-39
3.6.1 Description of Sequence Operation	3-40
3.6.2 Outline of Settings for Sequence Operation	3-47
3.6.3 Sequence Operation Procedure	3-48
3.7 External Control (Remote Control)	3-60
3.7.1 Analog Remote Control of C.C Mode	3-61
3.7.2 Analog Remote Control of C.R Mode	3-63
3.7.3 Analog Remote Control of C.P Mode	3-65
3.7.4 Remote Control of Load ON/OFF	3-66
3.7.5 Remote Control of Range Select	3-68
3.7.6 Trigger Signals	3-69
3.8 Master/Slave Parallel Operation	3-71

3.1 Descriptions of Front and Rear Panels

For the names and locations of the items on the front and rear panels, refer to the respective illustrations.

Front Panel

Refer to chapter 5. "5.1 Front Panel".

Rear Panel

Refer to chapter 5. "5.2 Rear Panel".

3.2 Initial Display When Power-on

As you press the POWER switch on the front panel, a sign-on message as shown below will appear on the display.

PLZ153W	30A	150W
I/F	None	

(This is an example.)

- The top row indicates the Series name, rated current and rated power.
- The bottom row indicates the type of the interface board connected to the Electronic Load.

Table 3.2-1

Display	Description
I/F None	No interface board is connected.
I/F GP01	GPIB interface board (device address 01) is connected.
I/F RS96	An RS-232C interface board (baud rate 9600 bps) is connected.
I/F MC01	An MCB interface board (device address 01) is connected.

▼ At about 2 seconds later

PLZ153W	30A	150W
Ver	1.00	

(This is an example.)

- The bottom row indicates the ROM Version Number.

▼ At about 2 seconds later

0.00A	0.00V	0.0W
-- ISET	0.00A H	--

(This is an example.)

- The top row indicates the current, voltage and power being fed to the Electronic Load.
- The bottom row indicates the mode (ISET for constant current mode in this example), the current setting (0.00 A in this example), and the range (H for high range in this example).

3.3 Basic Rules of Panel Operation

This section describes the basic rules of panel operation.

[1] Function select

The Electronic Load employs a one-key/one-function system, allowing you to select each of the basic functions directly and simply by pressing the corresponding key alone.

To escape from the currently engaged function also, all you have to do is to press the same key again or to press the **[ESC]** key.

[2] How to use the **[SHIFT]** key

You can select the function indicated with black letters on top of a key simply by pressing the key. To select the function indicated with blue letters below a key, you have to press the **[SHIFT]** key and then (or keeping it pressed) press the objective key.

To select the **SETUP** function, for example, press the **[SHIFT]** key first and then (or keeping it pressed) press the **[I SET]** key (below which the function **[SETUP]** is indicated with blue letters).

In this manual, key operation which involve the **[SHIFT]** key is indicated, for example, as follows:
[SHIFT] + **[I SET]** (setup)Press the **[SHIFT]** key first and then (or keeping it pressed) press the **[I SET]** key.
 This example is to select the **SETUP** function.

[3] Hierarchical menu system

Certain functional items are configured in a hierarchical menu system. To select one of these items, follow the guides indicated on the display by operating the keys as follows:

Select the required item with the **[▷]** or **[◁]** key and set the required value with the **JOG/SHUTTLE** dials. To advance to a lower level menu, press the **[ENTER]** key. To return to an upper level menu, press the **[ESC]** key.

[4] Operation error

If you press an invalid key, the buzzer will beep.

3.4 C.C Mode, C.R Mode, C.V Mode, and C.P Mode of Operation

The Electronic Load can operate in one of the four modes, namely, constant current (C.C) mode, constant resistance (C.R) mode, constant voltage (C.V) mode, and constant power (C.P) Mode.

■ Constant current (C.C) mode

In this mode the Electronic Load draws a constant current. That is, referring to Figure 3.4-1, current I remains constant regardless of change in voltage V_1 . Once you set the current at a certain value (5 A or 10 A, for example) in the C.C mode, the Electronic Load will draw this current (5 A or 10 A, for example) irrespective of source voltage change.

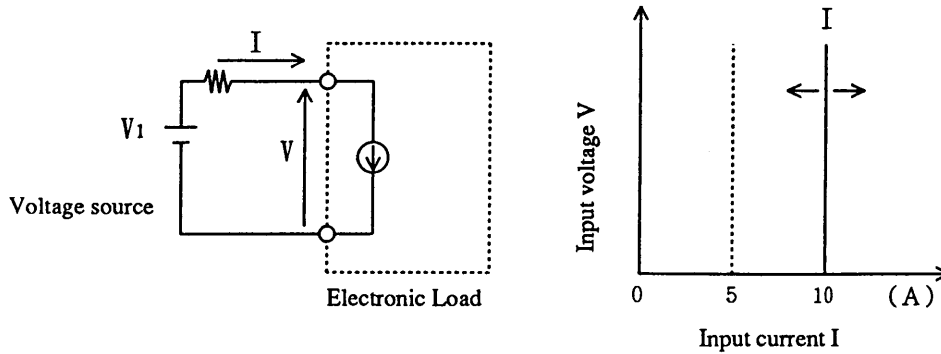

Figure 3.4-1

■ Constant resistance (C.R) mode

In this mode the Electronic Load exhibits a constant resistance. That is, referring to Figure 3.4-2, if voltage V_1 changes, V and I change so that the value of V/I becomes R which is the value set to be exhibited by the Electronic Load in the C.R mode.

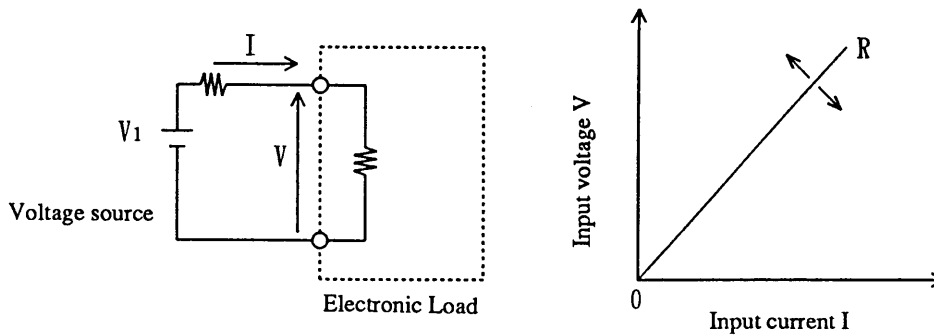

Figure 3.4-2

■ Constant voltage (C.V) mode

In this mode the Electronic Load acts as a constant voltage load. That is, referring to Figure 3.4-3, input voltage V remains constant at the preset voltage even when input current I is increased by increasing source voltage V_1 . Current I does not flow unless $V_1 > V$.

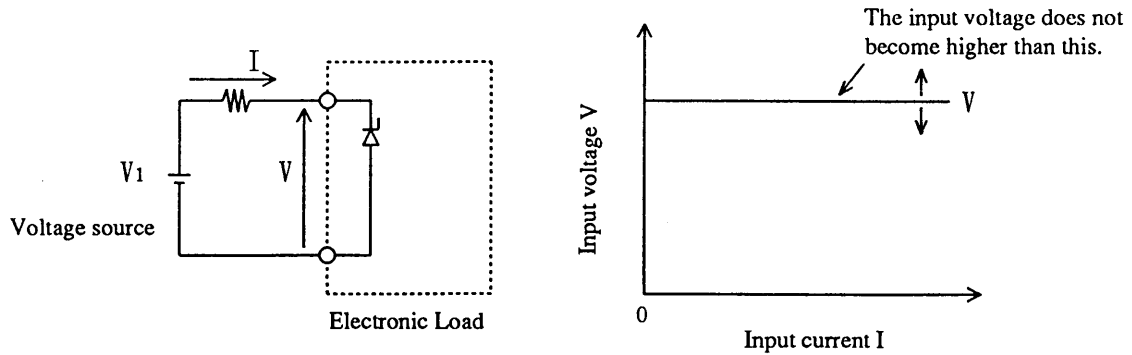

Figure 3.4-3

■ Constant power (C.P) mode

In this mode the Electronic Load draws a constant power. That is, referring to Figure 3.4-4, if source voltage V_1 becomes higher for example, input current I decreases so that power $P (= V \times I)$ is maintained constant at the preset value.

That is, a condition of $V_2 \times I_2 = V_3 \times I_3 = V \times I$ is maintained.

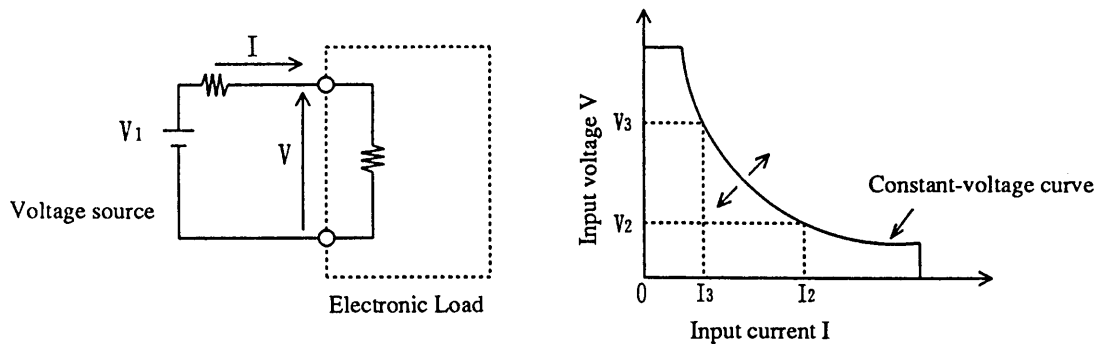

Figure 3.4-4

■ Operable range of Electronic Load

The operable of the Electronic Load is limited by its rated current, rated voltage and rated power. The range is as represented by the shaded area in Figure 3.5-4.

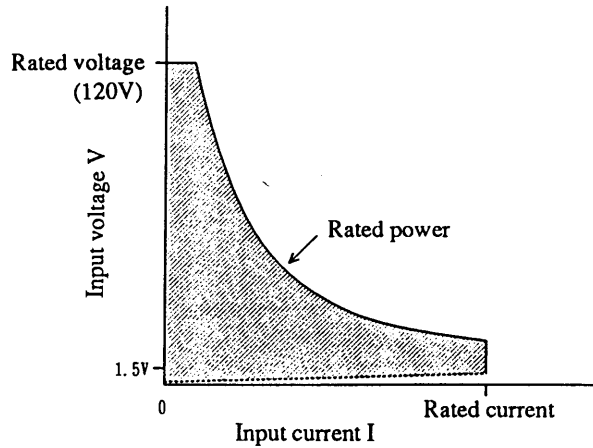

Figure 3.4-5

■ Operating mode transitions

Transitions among modes (C.C, C.R, C.V, C.P) of the Electronic Loads differ depending on its value setting and on the voltage and current settings of the equipment to be tested. That is, the mode transition point of Electronic Load varies depending on the setting of the value in that mode. Lighting of the C.C lamp (red) means that the Electronic Load is enabled to operate in the C.C mode; lighting of the CR lamp (red) means that it is enabled to operate in the C.C mode.

Transitions of modes due to input voltage change or input current change are as described below.

◎ Mode transition when C.C lamp is on

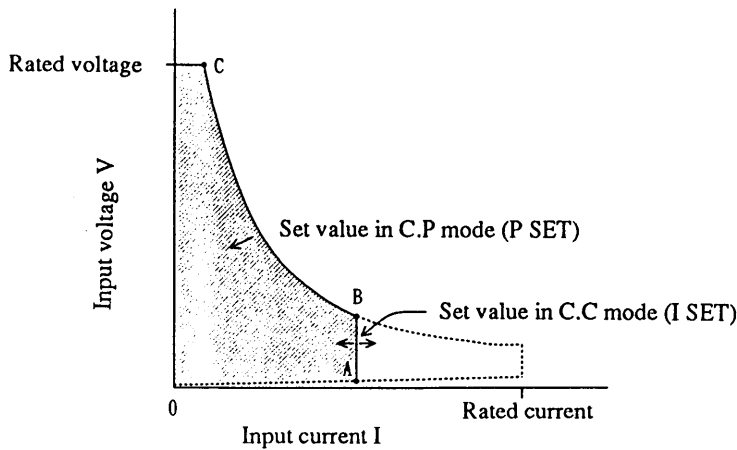

Figure 3.4-6

Referring to Figure 3.4-6, the Electronic Load operates in the C.C mode if its operating point is on line A-B or it operates in the C.P mode if its operating point is on line B-C. Referring to the model shown in Figure 3.4-1, as you gradually raise the source voltage V_1 , the operating point will start by point A and move up along line A-B in the C.C mode and, when it has reached point B, the mode will be change into the C.P mode and the current will start decreasing.

If you enable the C.V mode by pressing the **[SHIFT]** + **[V SET]** (CV ON) keys, mode transitions will be as follows:

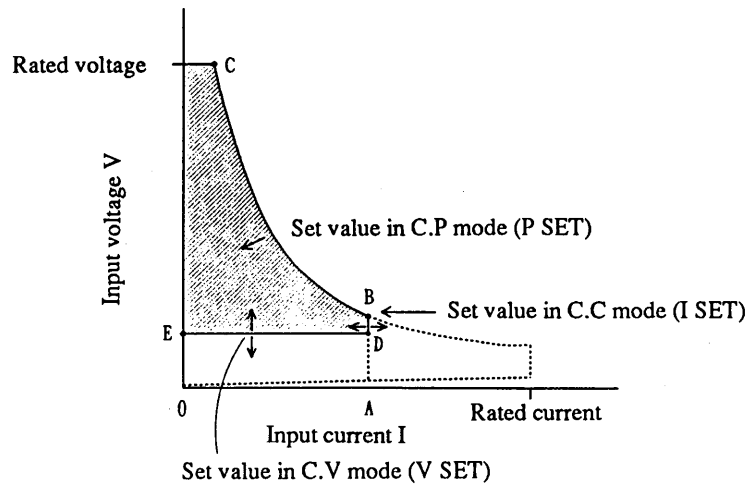

Figure 3.4-6

Referring to Figure 3.4-6, the Electronic Load operates in the C.V mode if its operating point is on line E-D. Referring to Figure 3.4-3, if V_1 becomes higher than V , the current starts flowing to keep current I constant. If V_1 becomes higher and reaches point D, the mode changes into the C.C mode. If it becomes still higher, the mode changes into the C.P mode.

☉ Mode transition when C.R lamp is on

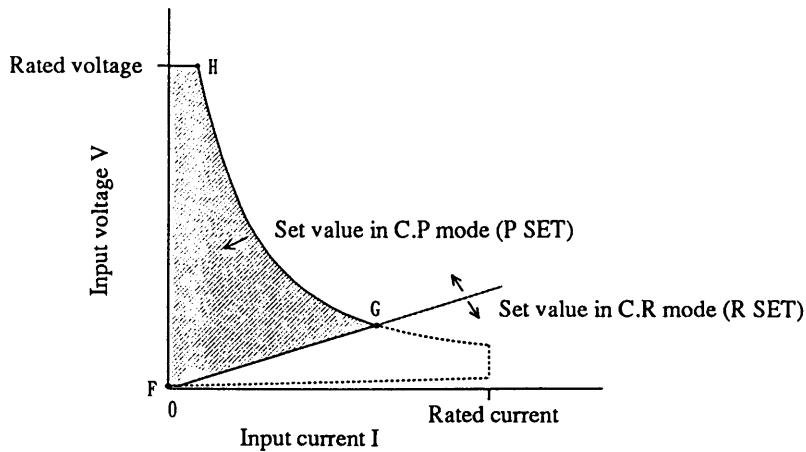

Figure 3.4-8

Referring to Figure 3.4-8, the Electronic Load operates in the C.R mode if its operating point is on line F-G or it operates in the C.P mode if its operating point is on line G-H. Referring to the model shown in Figure 3.4-2, as you gradually raise the source voltage V_1 , the operating point will move up along line F-G in the C.R mode and, when it has reached point G, the mode will be change into the C.P mode.

If you enable the C.V mode by pressing the **[SHIFT] + [V SET]**

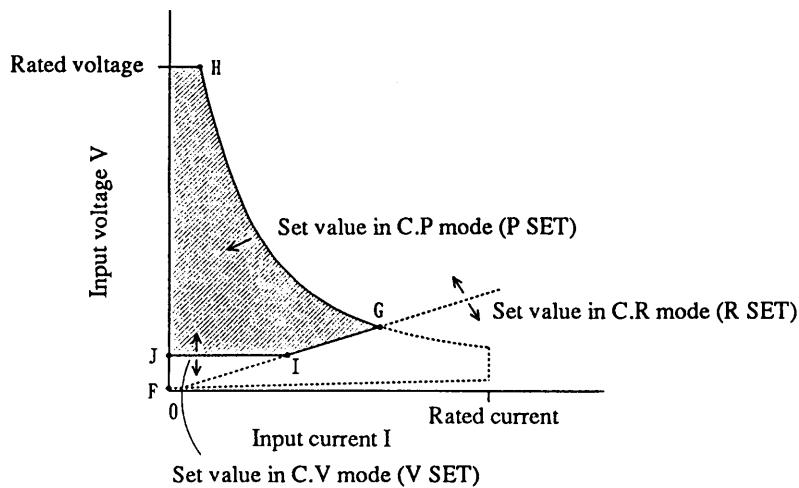
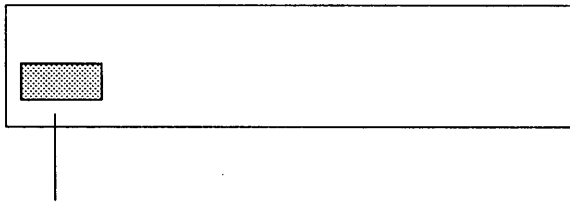

Figure 3.4-9

Referring to Figure 3.4-9, the Electronic Load operates in the C.V mode if its operating point is on line J-I. Referring to Figure 3.4-3, if V_1 becomes higher than V , the current starts flowing to keep current I constant. If V_1 becomes higher and reaches point I, the mode changes into the C.R mode. If it becomes still higher, the mode changes into the C.P mode.

■ Mode indication

The mode in which the Electronic Load is currently operating is indicated at lower left on the display.



CC	Operating in the C.C mode
CR	Operating in the C.R mode
CV	Operating in the C.V mode
CP	Operating in the C.P mode
--	Not in any of the above modes

3.5 Basic Operating Method

This chapter describes the basic operation method (local operation at the front panel) of the Electronic Load.

Before starting any of the procedures described below, initialize the Electronic Load by pressing the **[SHIFT] + [I SET]** (SET UP) keys, selecting [1: Initialize Setup] of the menu, and pressing the **[ENTER]** key.

Hereafter, the set value in the C.C mode is abbreviated as I SET value, that in the C.R mode as R SET value, that in the C.V mode as V SET value, and that in the C.P mode as P SET value.

3.5.1 C.C Mode of Operation

[1] Basic Procedures

■ Preparative Procedure

- With the **[P SET]** key, set the P SET value of the Electronic Load at a value (126 W in the below example) greater than the maximum power of the equipment to be tested. Also, set so that the Electronic Load does not draw abnormally large power from the equipment to be test (132 W in the below example).
- Be certain that **[-]** is indicated at lower left on the display.
If **[CV]** is indicated there, pressing the **[SHIFT] + [V SET]** (CV ON) keys so that **[CV]** goes out and **[-]** appears.

Instead of the above procedure, you may press the **[SHIFT] + [V SET]** (CV ON) keys, select the [1: Initialize Setup] of the menu, and press the **[ENTER]** key. In this case, the P SET value is set at the rated power of the Electronic Load.

■ Example: Setting the I SET value, switching the load ON/OFF, and changing the ranges

Assume that the following items are to be done when in the conditions as shown in Figure 3.5-1.

- (1) To enable the C.C mode and set the I SET value at 9.50 A, and
- (2) To switch the load ON/OFF, and
- (3) To change the ranges.

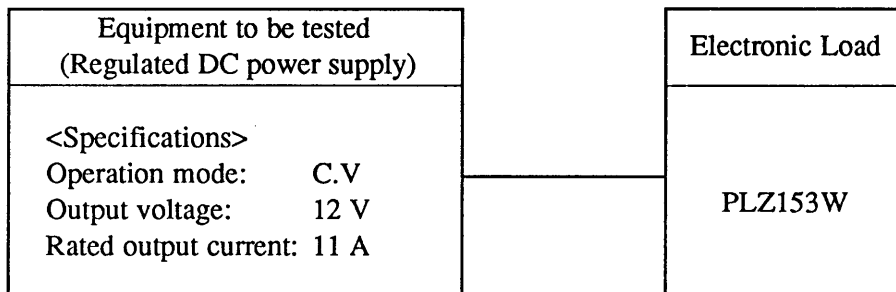

Figure 3.5-1

① Press the **[I SET]** key.

```

0 . 0 0 A  1 2 . 0 0 V    0 . 0 W
-- I SET   0 . 0 0 A  H  --

```

- The C.C lamp (red) above the **[I SET]** key illuminates.
- The C.C mode is enabled.
- On the bottom row, message **[I SET]** appears indicating that you can set a value for I SET. To its right, the currently existing setting **[0.00A]** is displayed.
- The top row indicates the voltage, current and power currently fed to the Electronic Load. (The power is as calculated by voltage \times current.)
- **[H]** denotes the High range.

NOTE

- If you press the **[I SET]** key when the CR lamp is ON and Electronic Load is in the load-on state, it will be driven into the load-off state.

② Adjust the I SET value by turning the SHUTTLE dial clockwise.

```

0 . 0 0 A  1 2 . 0 0 V    0 . 0 W
-- I SET   9 . 4 0 A  H  --

```

- The I SET value increases as you turn the SHUTTLE dial clockwise, and viceversa. The changing speed varies depending on the turned angle of the dial. In this example, the I SET value is set at 9.04 A.

③ Finely adjust the I SET value by turning the JOG dial clockwise.

```

0 . 0 0 A  1 2 . 0 0 V    0 . 0 W
-- I SET   9 . 5 0 A  H  --

```

- The I SET value finely increases as you turn the JOG dial clockwise, and vice versa.
- In this example, the I SET value is set at 9.50 A.

By the above procedure the Electronic Load has been set to the C.C mode, the I SET value at 9.50 A and the I SET value at 9.50 A. Next, to switch between the load-on and load-off states, proceed as follows:

④ Press the **[LOAD]** key.

```

9 . 5 0 A  1 1 . 9 5 V    1 1 3 . 5 W
CC I SET   9 . 5 0 A  H  --

```

- The load current flows and the green LED above the **[LOAD]** key illuminates to indicate the load-on state.
- Message **[CC]** appears at the left end on the bottom row, indicating that the Electronic Load is in the C.C mode.
- The top row indicates the current, voltage and power currently fed to the Electronic Load.

NOTE

- The causes of voltage reduction from 12.00 V to 11.95 V is the output voltage change of the regulated DC power supply and the voltage drop in the load wiring. (The voltage drop in the load wiring can be compensated for by remote sensing as described in Section 2.4.3.)

⑤ Press the **[LOAD]** key again.

```

0 . 0 0 A  1 2 . 0 0 V    0 . 0 W
-- I SET   9 . 5 0 A  H  --

```

- The Electronic Load becomes the load-off state, the display returns to the preceding state, and the LED above the **[LOAD]** key illuminates.

Now, let us proceed to the procedure of changing the ranges.

⑥ Press the **[LOAD]** key to set the Electronic Load to the load-on state and change the I SET value with the JOG/SHUTTLE dials.

10.50A	11.94V	125.4W
CC	ISET	10.50A H --

- As you turn the JOG/SHUTTLE dials when in the load-on state, the I SET value changes and the current drawn by the Electronic Load changes. In this example, the I SET value indicated on the bottom row has changed to 10.50 A and at the same time the readback current shown on the top row also has changed to 10.50 A.

⑦ Press the **[SHIFT]** + **[V SET]** (RANGE) keys and change the ranges.

3.00A	11.98V	35.9W
CC	ISET	3.000A L --

- [H] on the bottom row changes to [L], indicating that the ranges have been changed from High to Low. At the same time, the limit value of current changes to the maximum value of the Low range (3.00 A in this example).
- When in this state, the current will not increase beyond this limit even if you turn the JOG/SHUTTLE dial clockwise.

⑧ To return to the High range, press the **[SHIFT]** + **[P SET]** (RANGE) keys again.

3.00A	11.98V	35.9W
CC	ISET	3.00A H --

- [L] on the bottom row changes to [H], indicating that the ranges have been changed from Low to High.
- The I SET value remains at the maximum value of the Low range (3.00 A in this example).
- When in this state, the current can be increased by turning the JOG/SHUTTLE dial clockwise. (In this example, it is set at 3.00 A.)

Caution

- *When the inductance of the load wiring or that of the equipment to be tested is very large, turn off the load after fully reducing the current. (The load-on/off speed of the Electronic Load is approximately 400 μs.)*

[2] Setting the rise time (Tr) and fall time (Tf)

The rise time (Tr) or fall time (Tf) defines the period with which the current rises up from 10% to 90% of the set value or falls down from 90% to 10% of the set value in response to a stepwise change of the set value, when in the C.C mode, as shown in Figure 3.5-2. (The Tr and Tf are not applicable to the current rise up or fall down when in load-on or load-off operation.)

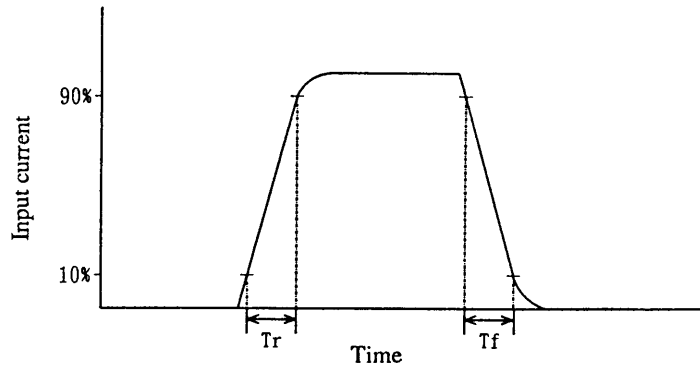

Figure 3.5-2

When the inductance of the equipment to be test is large or when that of the load wiring is large due to a longer load wiring distance and the Electronic Load is to be operated in the C.C mode, you may set Tr and Tf at a larger value to avoid over voltages that could be caused by the inductance and rapid current change.

Caution

- If the inductance is large, the setup may become unstable or may oscillate. This is especially true when the voltage at the load terminal of the Electronic Load is low.

Example: Selecting a Tr Tf value

① Press the **[Tr Tf]** key.

```

0 . 0 0 A   1 2 . 0 0 V   0 . 0 W
--          T r   T f       5 0 μ s

```

- Message [Tr Tf] appears on the bottom row, indicating the the Tr Tf setting mode is enabled.
- The currently set Tr Tf time (50 μs in this example) appears at the right hand end.

② Select a Tr Tf time by turning the JOG dial clockwise.

```

0 . 0 0 A   1 2 . 0 0 V   0 . 0 W
--          T r   T f       1 0 m s

```

- Select a new value with the JOG dial.
- The new values are entered automatically.
- For the value, you can select 50 μs, 100 μs, 200 μs, 500 μs, 1 ms, 2 ms, 5 ms, or 10 ms.
- In this example, it is set at 10 ms.

③ Press the **[Tf Tf]** key or **[ESC]** key again.

```

0 . 0 0 A   1 2 . 0 0 V   0 . 0 W
-- I SET   8 . 0 0 A   H   --

```

- The original display will resume.

[3] Setting the soft start time

The soft start function is such that, when in the C.C mode, the current drawn by the Electronic Load gradually rises up with respect to the rise up of the output voltage of the equipment to be tested. The soft start time defines the rise up time of the current.

Assume that a test setup is prepared as shown in Figure 3.5-3, the C.C mode is selected, and switch S_1 is turned on.

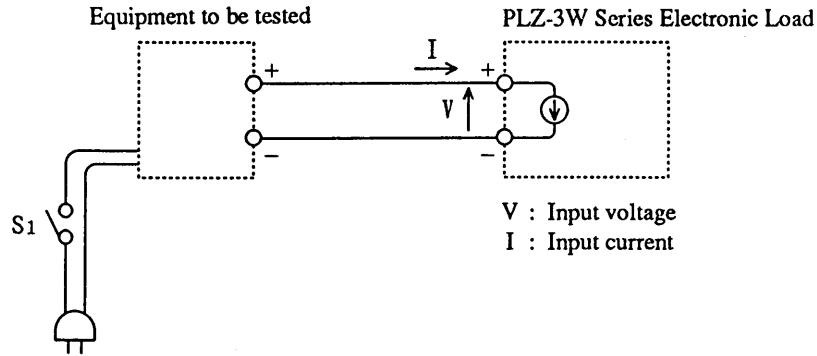

Figure 3.5-3

If the soft start time is 0.1 ms, the relationships between V and I will be as shown in Figure 3.5-4.

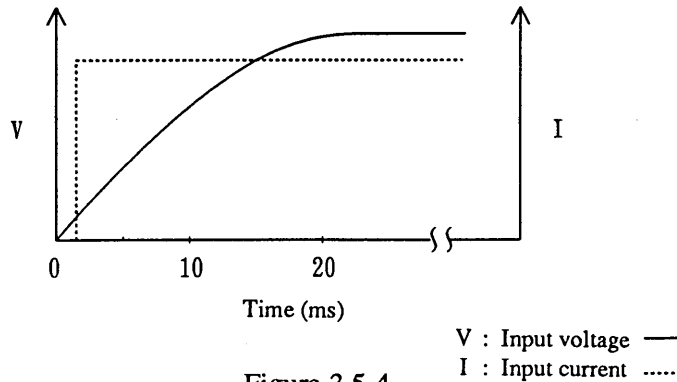

Figure 3.5-4

If the soft start time is 20 ms, the relationships between V and I will be as shown in Figure 3.5-5.

Thus, by setting the soft start time at an appropriate value, the setup can be made so that the output current rises up following the rising up of the output voltage of the equipment to be tested.

Caution

- Allow a period of 1 second or more between turning on and off of switch S_1 .

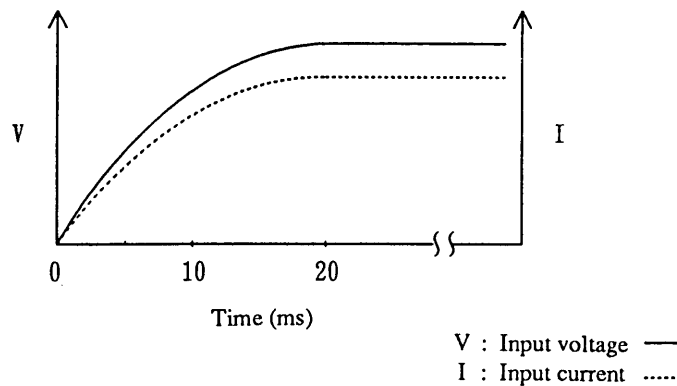

Figure 3.5-5

■ Example: Selecting a soft start time

① Press the **[SHIFT]** + **[Tr Tf]** (START TIME) keys.

0 . 0 0 A	1 2 . 0 0 V	0 . 0 W
--	START TIME	0 . 1 m s

- Message [START TIME] appears on the bottom row, indicating that the softstart time setting mode is enabled.
- The currently set start time (0.1 ms in this example) appears at the right hand end.

② Select a soft start time by turning the JOG dial clockwise.

0 . 0 0 A	1 2 . 0 0 V	0 . 0 W
--	START TIME	2 0 m s

- Select a new value with the JOG dial.
- The new values are entered automatically.
- For the value, you can select 0.1 ms, 1 ms, 2 ms, 5 ms, 10 ms, 20 ms, 50 ms, or 100 ms. In this example, it is set at 20 ms.

③ Press the **[SHIFT]** + **[Tr Tf]** (START TIME) keys again.

0 . 0 0 A	1 2 . 0 0 V	0 . 0 W
--	IS ET	8 . 0 0 A H --

- The original display will resume.

3.5.2 C.R Mode of Operation

■ Preparative Procedure

- With the **[P SET]** key, set the P SET value of the Electronic Load at a value (100 W in the below example) greater than the maximum power of the equipment to be tested. Also, set so that the Electronic Load does not draw abnormally large power from the equipment to be test.
- Be certain that [-] is indicated at lower left on the display.
If [CV] is indicated there, pressing the **[SHIFT] + [V SET]** (CV ON) keys so that [CV] goes out and [-] appears.

Instead of the above procedure, you may press the **[SHIFT] + [I SET]** (SETUP) keys, select the [1: Initialize Setup] of the menu, and press the **[ENTER]** key. In this case, the P SET value is set at the rated power of the Electronic Load.

Caution

- Do not feed a current larger than the rated current of the Electronic Load. If such current is fed, the OVP will trip to limit the current and generate an alarm.

■ Example: Setting the R SET value, switching the load ON/OFF, and changing the ranges

Assume that the following items are to be done when in the conditions as shown in Figure 3.5-6.

- (1) To enable the C.R mode and set the R SET value at 0.5022Éð,
- (2) To switch the load ON/OFF, and
- (3) To change the ranges.

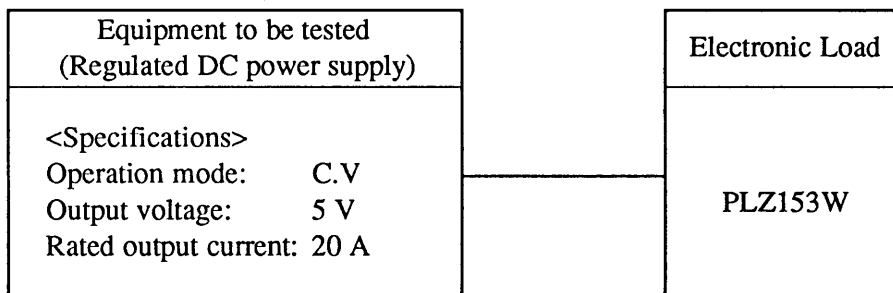

Figure 3.5-6

- ① Press the **[R SET]** key.

0 . 0 0 A	5 . 0 0 V	0 . 0 W
-- R SET	5 0 0 0 . Ω	H --

- The C.R lamp (yellow) above the **[R SET]** keys illuminates indicating that the C.R mode is enabled.
- On the bottom row, message [R SET] appears indicating that you can set a value for R SET. To its right, the currently existing setting [5000.Ω] is displayed.
- The top row indicates the voltage, current and power currently fed to the Electronic Load. (The power is as calculated by voltage × current.)
- [H] on the bottom row denotes the Highrange.

NOTE

- If you press the **[R SET]** key when the C.C lamp is ON and Electronic Load is in the load-on state, it will be driven into the load-off state.

- ② Adjust the R SET value by turning the SHUTTLE dial clockwise.

0 . 0 0 A	5 . 0 0 V	0 . 0 W
-- R S E T	. 5 2 6 0 Ω	H --

- The R SET value decreases as you turn the SHUTTLE dial clockwise, and vice versa.
- The changing speed varies depending on the turned angle of the dial.
- In this example, the R SET value is set at 0.5260 Ω.

- ③ Finely adjust the R SET value by turning the JOG dial clockwise.

0 . 0 0 A	5 . 0 0 V	0 . 0 W
-- R S E T	. 5 0 2 2 Ω	H --

- The R SET value finely decreases as you turn the JOG dial clockwise, and vice versa. In this example, the R SET value is set at 0.5022 Ω.

By the above procedure the Electronic Load has been set to the C.R mode and the R SET value at 0.5022 Ω. Next, to switch between the load-on and load-off states, proceed as follows:

- ④ Press the **[LOAD]** key to set the Electronic Load to the load-on state.

9 . 8 5 A	4 . 9 5 V	4 8 . 8 W
C R R S E T	. 5 0 2 2 Ω	H --

- The load current flows and the green LED above the **[LOAD]** key illuminates to indicate the load-on state.
- Message [CR] appears at the left end on the bottom row, indicating that the Electronic Load is in the C.R mode.
- The top row indicates the current, voltage and power currently fed to the Electronic Load. (The power is as calculated by voltage × current.)

NOTE

- *The causes of voltage reduction from 5.00 V to 4.95 V is the output voltage change of the regulated DC power supply and the voltage drop in the load wiring. (The voltage drop in the load wiring can be compensated for by remote sensing as described in Section 2.4.3.)*

- ⑤ Press the **[LOAD]** key again to return to the load-off state.

0 . 0 0 A	5 . 0 0 V	0 . 0 W
-- R S E T	. 5 0 2 2 Ω	H --

- The Electronic Load becomes the load-off state, the display returns to the preceding state, and the LED above the **[LOAD]** key illuminates.

Now, let us proceed to the procedure of changing the ranges.

- ⑥ Press the **[LOAD]** key to set the Electronic Load to the load-on state and change the R SET value with the JOG/SHUTTLE dials.

1 4 . 7 5 A	4 . 9 3 V	7 2 . 7 W
C R R S E T	. 3 3 4 2 Ω	H --

- As you turn the JOG/SHUTTLE dials when in the load-on state, the R SET value changes and the current drawn by the Electronic Load changes. In this example, the I SET value indicated on the bottom row has changed to 0.3342 Ω and at the same time the readback current shown on the top row also has changed to 14.75 A. Thus, the values can be changed real-time.

⑦ Press the **【SHIFT】** + **【P SET】** (RANGE) keys and change the ranges.

5 . 2 3 A	4 . 9 8 V	2 5 . 8 W
C R	R S E T . 9 5 2 4 Ω	L --

- [H] on the bottom row changes to [L], indicating that the ranges have been changed from High to Low. At the same time, the R SET value is limited at the minimum value (0.9524 Ω in this example) of the L range and the current falls.
- When in this state, the the resistance will not become small than this and the current will not increase even if you turn the JOG/SHUTTLE dial clockwise.

⑧ To return to the High range, press the **【SHIFT】** + **【P SET】** (RANGE) keys again.

5 . 2 3 A	4 . 9 8 V	2 5 . 8 W
C R	R S E T . 9 5 2 4 Ω	H --

- [L] on the bottom row changes to [H], indicating that the ranges have been changed from Low to High.
- The R SET value remains at the minimum value of the Low range (0.9534 Ω in this example).
- When in this state, the current can be increase by turning the JOG/SHUTTLE dial clockwise.

Caution

• *When the inductance of the load wiring or that of the equipment to be tested is very large, turn off the load after fully reducing the current. (The load-on/off speed of the Electronic Load is approximately 400 μs.)*

3.5.3 C.V Mode of Operation

■ Preliminary Procedure

- With the **[P SET]** key, set the P SET value of the Electronic Load at a value (100 W in the below example) greater than the maximum power of the equipment to be tested. Also, set so that the Electronic Load does not draw abnormally large power from the equipment to be test.
- With the **[I SET]** key or **[R SET]** key, set a current which is allowable to be fed from the equipment to be tested (23 A in the below example).

NOTE

- *This mode can be effectively used to evaluate the constant current performance of the equipment to be tested.*

■ Example: Setting the V SET value and switching to load-on

Assume that the following items are to be done when in the conditions as shown in Figure 3.5-6.

- (1) To enable the C.V mode and set the V SET value at 4.8 V, and
- (2) To switch to the load-on state.

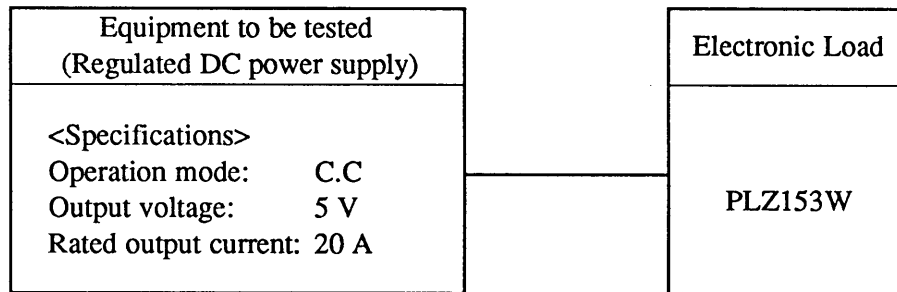

Figure 3.5-7

- ① Press the **[SHIFT] + [V SET]** (CV ON) keys to enable the C.V mode.

```

0 . 0 0 A   5 . 0 0 V   0 . 0 W
-- I S E T  2 3 . 0 0 A   H   C V

```

- At the right hand end of the bottom row, indicating that the C.V mode is enabled.

- ② Press the **[V SET]** key.

```

0 . 0 0 A   5 . 0 0 V   0 . 0 W
-- V S E T   0 . 0 0 V   H   C V

```

- At the right hand end, message **[V SET]** appears indicating that you can set a V SET value.
- Data **[0.00V]** on the bottom row is the currently existing V SET value.

Now let us set a V SET value and switch to the load-on state.

- ③ With the JOG/SHUTTLE dials, set the V SET value at a voltage lower than the output voltage of the regulated DC power supply (5.00 V in this example).

```

0 . 0 0 A   5 . 0 0 V   0 . 0 W
-- V S E T   4 . 8 0 V   H   C V

```

- In this example, we have set the voltage at 4.80 V.

- ④ Press the **【LOAD】** key to switch the Electronic Load to the load-on state.

20.00A	4.80V	96.0W
CV	VSET	4.80V H CV

- The green LED above the **【LOAD】** key illuminates to indicate the Electronic Load is in the load-on state.
- Message [CV] appears at the left end on the bottom row, indicating that the Electronic Load is operating in the C.Vmode.
- The top row indicates the current, voltage and power currently fed to the Electronic Load. (The power is as calculated by voltage × current.)
- Readback data [20.00A] appears at the left hand end on the top row, indicating that the rated current is drawn from the regulated DC power supply.

NOTE

- Note that the Electronic Load will not operate in the C.V mode if the I SET value is smaller than the constant current setting of the regulated DC power supply.
- When changing from the C.C or C.R mode to the C.V mode, the voltage may overshoot or undershoot depending on the response speed and the capacitance of the output capacitor of the Electronic Load.

To prevent overshoot and undershoot, set the V SET value in beforehand at a higher value so that the mode will not change into C.V and, after switching the Electronic Load to the the load-on state, lower the V SET value to enable the C.V mode.

Another method of preventing overshoot and undershoot is to gradually change the set value to the required target value.

3.5.4 C.P Mode of Operation

■ Preliminary Procedure

- With the **[I SET]** key or **[R SET]** key, set a current which is allowable to be fed from the equipment to be tested (20 A in the below example).
- Be certain that **[-]** is indicated at lower left on the display.
If **[CV]** is indicated there, pressing the **[SHIFT] + [V SET]** (CV ON) keys so that **[CV]** goes out and **[-]** appears.

■ Example: Setting the P SET value and switching to load-on

Assume that the following items are to be done when in the conditions as shown in Figure 3.5-8.

- (1) To enable the C.P mode and set the P SET value at 80 W, and
- (2) To switch to the load-on state.

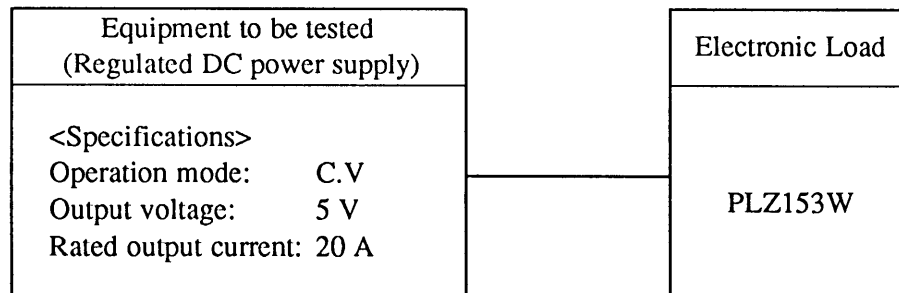

Figure 3.5-8

- ① Press the **[P SET]** key to enable the C.V mode.

0 . 0 0 A	5 . 0 0 V	0 . 0 W
-- P S E T	1 5 7 . 5 W	--

- On the bottom row, message **[P SET]** appears indicating that the CP mode is enabled.

- ② With the JOG/SHUTTLE dials, set the P SET value.

0 . 0 0 A	5 . 0 0 V	0 . 0 W
-- P S E T	8 0 . 0 W	--

- In this example, we have set the power at 80.0W.

- ③ Press the **[LOAD]** key to switch the Electronic Load to the load-on state.

1 6 . 2 0 A	4 . 9 5 V	8 0 . 2 W
CP P S E T	8 0 . 0 W	--

- The green LED above the **[LOAD]** key illuminates to indicate that the Electronic Load is in the load-on state.
- Message **[CP]** appears at the left end on the bottom row, indicating that the Electronic Load is operating in the C.P mode.
- The top row indicates the current, voltage and power currently fed to the Electronic Load. (The power is as calculated by voltage \times current.)

NOTE

- The causes of voltage reduction from 5.00 V to 4.95 V are the output voltage change of the regulated DC power supply and the voltage drop in the load wiring. (The voltage drop in the load wiring can be compensated for by remote sensing as described in Section 2.4.3.)
- The current may overshoot if the Electronic Load is abruptly changed to the C.P mode by load-on or other event.

3.5.5 Memory Function

The Electronic Load has three memory units, namely, memory A, memory B, and memory C. You can save data to and recall it from the memory units as shown in Table 3.5-1.

Table 3.5-1

	Memory A	Memory B	Memory C
C.C mode	<ul style="list-style-type: none"> • I SET value • Range • Switching execution time 	Same as left	Same as left
C.R mode	<ul style="list-style-type: none"> • R SET value • Range • Switching execution time 	Same as left	Same as left
C.V mode	<ul style="list-style-type: none"> • V SET value 	Same as left	Same as left
C.P mode	<ul style="list-style-type: none"> • P SET value 	Same as left	Same as left

For details of the "switching execution time," refer to Section 3.5.6 "Switching Function."

[1] Saving data onto memory A, B, or C

This section describes the methods to save setting data onto memory A, B, or C. There are two methods—one is to use the [MEM] key and the other is to use the [SHIFT] + [MEM] (DMEM) keys. Use an appropriate one of the methods by referring to the description given below.

■ Example: Data save by [MEM] key

This method is to save directly the setting value and range currently indicated on the display. (To save the switching execution time, you should use the [SHIFT] + [MEM] (DMEM) keys.)

- ① In the load-on state, press the [I SET] , [R SET] , [P SET] or [V SET] key depending on the mode for which the setting data is to be saved.

5 . 0 0 A	1 2 . 0 0 V	6 0 . 0 W
CC I SET	5 . 0 0 A	H --

- For this example, press the [I SET] key to select the C.C mode for which the setting data is to be saved. Message [I SET] will appear on the bottom row.

If you want to save data for the C.R, C.P or C.V mode, press the [R SET] , [P SET] or [V SET] key, respectively.

- ② Adjust the setting data as you may require with the JOG/SHUTTLE dials.

1 0 . 0 0 A	1 2 . 0 0 V	1 2 0 . 0 W
CC I SET	1 0 . 0 0 A	H --

- In this example, the current is set at 10.00 A. [H] denotes the High range.

- ③ Press the **【MEM】** key.

```
10.00A 12.00V 120.0W
CC MEM<ABC> Save Mode
```

- Message [MEM <ABC> Save Mode] appears on the bottom row, indicating that the save mode is enabled.

- ④ Press the **【A】** key to save data in memory A.

```
10.00A 12.00V 120.0W
CC MEM<ABC> Save A
```

- As you press the **【A】** key, the setting data (current 10.00A and range H) is saved onto memory A.
- If you press the **【B】** key now, the same data is saved onto memory B and **【A】** at the right end on the bottom row changes to **【B】**.

- ⑤ Press the **【MEM】** key again or press the **【ESC】** key.

```
10.00A 12.00V 120.0W
CC ISET 10.00A H --
```

- The initial display will resume.
- If you want to set another item of data, repeat an identical procedure.

■ Example: Data save by **【SHIFT】** + **【MEM】** (DMEM) keys

This method is to modify directly the contents of the data stored on memory, without changing the data indicated on the display. If you use this method, you can change the switching execution time as well as the current, resistance, power or voltage data and the range.

- ① In the load-on state, press the **【I SET】**, **【R SET】**, **【P SET】** or **【V SET】** key depending on the mode for which the setting data is to be saved.

```
5.00A 12.00V 60.0W
CC ISET 5.00A H --
```

- For this example, press the **【I SET】** key to select the C.C mode for which the setting data is to be saved. Message [I SET] will appear on the bottom row.

If you want to save data for the C.R, C.P or C.V mode, press the **【R SET】**, **【P SET】** or **【V SET】** key, respectively.

- ② Press the **【SHIFT】** + **【MEM】** (DMEM) keys and adjust the setting data as you may require with the JOG/SHUTTLE dials.

```
5.00A 12.00V 60.0W
CC I value<A> 10.00A
```

- Message [I value <A>] appears indicating denotes memory A.
- Data [10.00A] at the right hand end on the bottom row indicates the readback of data of memory A.
- Note that the indication at the left hand end remains at 5.00A. This means that, while the existing setting remains unchanged, the value saved on the memory alone has been modified.
- You can modify the value to be saved on memory with the JOG/SHUTTLE dials.
- As you escape from the save mode, the data is automatically entered.

③ Press the **[▷]** key to select the next item of data.

```
5.00A   12.00V   60.0W
CC  I range<A> High
```

- Message [I range <A>] appears indicating that the data item has been changed to [range]. Memory unit remains unchanged yet at A.
- Message [High] on the bottom row means that the current range of memory A is High. The range can be changed with the JOG dial.

④ Press the **[B]** key to select memory B. Press the **[▷]** key to change the data item to "switching time."

```
5.00A   12.00V   60.0W
CC  I time <B>      1mS
```

- [**<A>**] on the bottom row has changed to [****], indicating that memory B has been selected instead of memory A.
- Also, [I range] has changed to [T time], indicating that the data item has been changed to "switching time." In this example, [1 ms] appears at the righthand end of the bottom row, indicating that the switching execution time set on memory B is 1 ms.
- You can change the switching execution time with the JOG dial.

⑤ Press the **[C]** key to select memory C. Press the **[◀]** key twice to change the data item to "I SET value."

```
5.00A   12.00V   60.0W
CC  I value<C>  10.00A
```

- [****] on the bottom row has changed to [**<C>**], indicating that memory C has been selected instead of memory B.
- Also, [I time] has been changed to [I value, indicating that the data item has been changed to "I SET value." In this example, [10.00A] appears at the right hand end of the bottom row, indicating that the current value saved on memory C is 10.00 A.
- You can change the current value with the JOG/SHUTTLE dials.

⑥ To escape from the data save mode, press the **[SHIFT] + [MEM]** (DMEM) keys again or press the **[ESC]** key.

[2] Recalling data from memory A, B, or C**■ Example: Recalling data in the C.C mode**

① In the load-on state, press the **[I SET]** key to enable the C.C mode.

5.00A	12.00V	60.0W		
CC	ISET	5.00A	H	--

- For this example, press the **[I SET]** key to select the C.C mode for which the setting data is to be recalled. As you press the key, message **[I SET]** denoting the C.C mode appears on the bottom row.

If you want to recall data for the C.R, C.P or C.V mode, press the **[R SET]** , **[P SET]** or **[V SET]** key, respectively.

② Press the **[A]** key to recall data from memory A.

10.00A	12.00V	60.0W		
CC	ISET	10.00A	H	--

- Data [10.00A] is recalled from memory A and displayed on the bottom row. The current drawn by the Electronic Load has changed from [5.00A] to [10.00A].

As the Electronic Load is directly set by the value recalled from the memory, this method is called "direct setting" method.

③ Press the **[B]** key to recall data from memory B.

2.00A	12.00V	60.0W		
CC	ISET	2.000A	L	--

- Data [2.000A] of memory B is recalled and directly set, and it is indicated at the left hand end of the top row and at the center of the bottom row.
- As the range stored on memory B in this example is Low, the Electronic Load is set to the Low range and **[L]** appears at the right hand end of the bottom row.

NOTE

- If you select *[Safety]* from configuration menu [4: Recall ABC Mem.], the output does not change to the new value until you acknowledge the value by pressing the **[ENTER]** key.

3.5.6 Switching Function

The Electronic Load has a switching function that, when in the C.C or C.R mode, it can sequentially recall data items stored in memory units A, B and C, and sequentially execute them in the order of A, B, C, A, B, C.. for the execution period settings of respective modes. This function is advantageous especially for evaluation of response characteristics of regulated DC power supplies and the like.

■ Preliminary procedure

- For switching in the C.C mode, set the Tr Tf time and data values in memory units A, B and C as described in Section 3.5.1 "C.C Mode of Operation."
- For switching in the C.R mode, set the data values in memory units A, B and C as described in Section 3.5.1 "C.C Mode of Operation."

NOTE

- You can change the rise time and fall time of the current in the C.C mode by using the [Tr Tf] key when in the switching operation.
- You can change the current value or resistance value and the execution time by using the [SHIFT] + [MEM] (DMEM) keys when in the switching operation.
- The switching operation is executed with the High range even when the data saved in memory is for the Low range.
- The rise time and fall time of the switching current in the C.R mode are approximately 200 μ s (assuming that the input voltage is constant).

■ Example: Description of switching operation (in C.C mode for example)

Assume that data stored on memory units A, B and C are as shown in Table 3.5-2. The switching actions in this case will be as shown in Figure 3.5-9.

Table 3.5-2

	Memory A	Memory B	Memory C
I SET value	10 A	5 A	2 A
Execution time	5 ms	10 ms	20 ms
Range	High	High	High

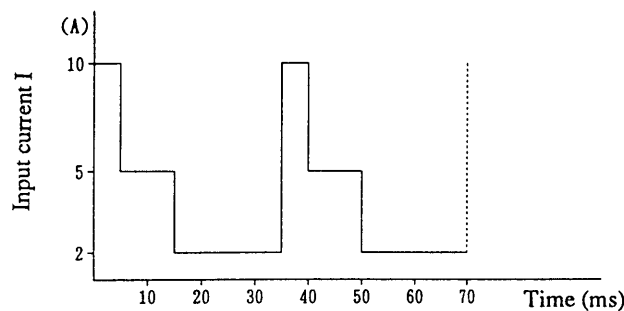

Figure 3.5-9

NOTE

- If you need a trigger signal delivered in synchronization with the switching timing, press the [SHIFT] + [R SET] (CONFIG) keys to display the configuration menu and select [ON] of menu [8: SW Trig Out]. If you do this, a trigger pulse signal (in synchronization with the switching points shown in Figure 3.5-9, for example) will be delivered. A trigger output terminal for this purpose is provided on the front sub-panel. The trigger output signal is delivered also to the trigger output terminal of the external control connector on the rear panel.

■ Example: Procedure for switching operation (in C.C mode for example)

① Press the [I SET] or [R SET] key to enable the switching mode of operation.

0 . 0 0 A	1 2 . 0 0 V	0 . 0 W
-- I SET	9 . 4 0 A	H --

- For this example, press the [I SET] key to select the C.C mode of switching operation. Message [I SET] will appear on the bottom row. If you want to select the C.R mode of switching operation, press the [R SET] key.

NOTE

- If you select the C.C mode of switching operation, the I SET values saved on memory units A, B and C are recalled. If you select the C.R mode of switching operation, the R SET values saved on memory units A, B and C are recalled. (Refer to Section 3.5.5 "Memory Function.")

② Press the [SW] key to enable the switching mode.

0 . 0 0 A	1 2 . 0 0 V	0 . 0 W
-- I < C >	2 . 0 0 A	2 0 m s

- The green LED above the [SW] key illuminates to indicate that the switching operation is enabled.
- The messages on the bottom row indicates that the data recalled from memory C is [2.00A] for the current and [20ms] for the switching time. The messages by the data values recalled sequentially from memory units A, B and C.
- The top row indicates the current, voltage and current fed now to the Electronic Load. (The power is as calculated by voltage × current.) At this stage of operation, as the Electronic Load is not driven into the load-on state although the switching action alone has started, the power is 0.

③ Press the [LOAD] key for load-on.

2 . 0 0 A	1 1 . 9 5 V	2 3 . 9 W
CC I < C >	2 . 0 0 A	2 0 m s

- The green LED above the [LOAD] key illuminates to indicate that the Electronic Load has been driven into the load-on state. The top row indicates the current, voltage and current fed now to the Electronic Load.
- Message [CC] appears at the left hand end of the bottom row indicating that the Electronic Load is operating in the C.C mode.
- The memory name, value setting and execution time recalled and indicated on the bottom row change as memory units A, B and C are switched sequentially.

3.5.7 Keylock Function

To lock the keys, press the **[SHIFT] + [STOP] (KEYLOCK)** keys. As you do this, the keys and dials on the front panel and sub-panel are disabled, thereby guarding the current settings against unnecessary alterations. (Even when in this state, the **[SHIFT] + [STOP] (KEYLOCK)** keys alone remain enabled.)

NOTE

- The keylock function allows you to selectively lock the keys as follows (refer to Section 3.3.9 "Configuration").
- To disable the **[SW]** key, press the **[SHIFT] + [R SET] (CONFIG)** keys and then select the [Lock] of [6: SW Key] of the menu.
- To disable the **[SHIFT] + [SW] (SHORT)** keys, press the **[SHIFT] + [R SET] (CONFIG)** keys and then select the [Lock] of [7: SHORT Key] of the menu.
- To disable the **[A]**, **[B]** and **[C]** keys, press the **[SHIFT] + [R SET] (CONFIG)** keys and then select the [Lock] of [5: ABC Key] of the menu.

■ **Example: To lock/unlock the keys**

① Press the **[SHIFT] + [STOP] (KEYLOCK)** keys to lock the keys.

```
0.00A 12.00V 0.0W
-- << Keys Locked >>
```

- Message [**<< Keys Locked >>**] will appear on the bottom row, indicating that the keys are locked.

② Press the **[SHIFT] + [STOP] (KEYLOCK)** keys again to unlock the the keys.

```
2.00A 12.00V 0.0W
-- ISET 9.40A H --
```

- The keys are unlocked and the original display resumes.

Each time as you press the **[SHIFT] + [STOP] (KEYLOCK)** keys, the keys are locked or unlocked as above.

NOTE

- You cannot unlock the keys by pressing the **[ESC]** key.

3.5.8 Setup Resume Function and Backed-up Memory

The Electronic Load has a function to store automatically the setup (a group of settings of operation parameters) at the power-off event and to resume automatically the setup at the next power-on event.

The Electronic Load has a memory backed-up by a battery, which can store up to four setups. The battery is charged continuously during the period the Electronic Load is in the power-on state. In the power-off state, the memory can hold the stored data for approximately 30 days.

Table 3.5-3 Setup data items

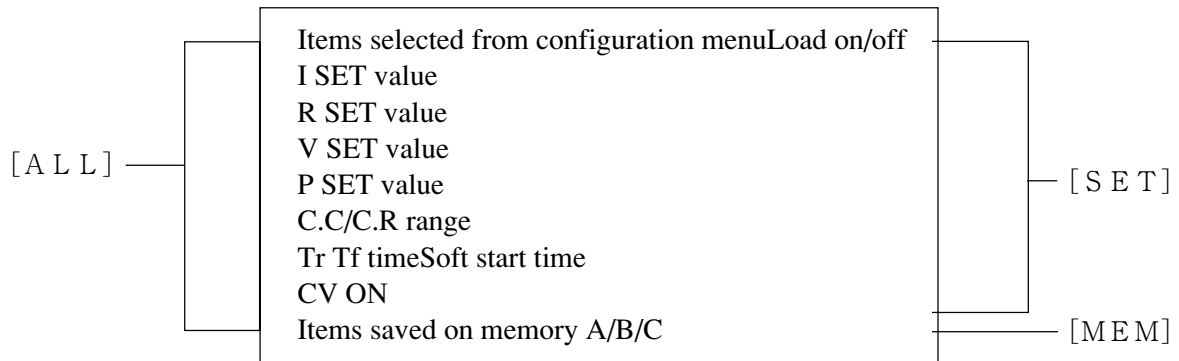

[Menu for Store/Recall of Setups]

Setup Store/Recall Functions

- 1 : [Initialize Setup] ; To initialize the values of the setup data items.
- 2 : [Store [ALL]] ; To store the [ALL] items of Table 3.5-3 onto the backed-up memory.
- 3 : [Recall [ALL]] ; To recall the [ALL] items of Table 3.5-3 from the backed-up memory.
- 4 : [Store [SET]] ; To store the [SET] items of Table 3.5-3 onto the backed-up memory.
- 5 : [Recall [SET]] ; To recall the [SET] items of Table 3.5-3 from the backed-up memory.
- 6 : [Store [MEM]] ; To store the [MEM] items of Table 3.5-3 onto the backed-up memory.
- 7 : [Recall [MEM]] ; To recall the [MEM] items of Table 3.5-3 from the backed-up memory.

NOTE

- If you select [1: Initialize Setup] from the menu, the procedure automatically escapes from the menu mode. To escape from [2:] through [7:] of the menu, press the **[ESC]** key.

Table 3.5-4

<Initial values of setup>	
Items selected from configuration menu	: As initialized
Load on/off	: Off
I SET value	: 0 A
R SET value	: Maximum
V SET value	: 0 V
P SET value	: Maximum
C.C/C.R range	: High
Tr Tf time	: 50 μ s
Soft start time	: 0.1ms
CV ON	: OFF
Items saved on memory A/B/C	: As above for each mode

NOTE

- The factory-defaults for the setup are as shown in Table 3.5-4.

■ Example: To recall/store a setup

- ① Press the **【SHIFT】** + **【SETUP】** (SETUP) keys.

```
>1:Initialize Setup
    Push [ENTER]
```

- The setup initialize menu appears.
- As you press the **【ENTER】** key, the setup is initialized and then the original display resumes.

- ② Press the **【SHIFT】** + **【SETUP】** (SETUP) keys again and then press the **【▷】** key.

```
>2:Store [ALL]
    1
```

- The menu item for storing the [ALL] items of Table 3.5-3 onto the backed-up memory.
- The number on the bottom row denotes the memory location number. Numbers 1 through 4 are for storing on the backed-up memory.

- ③ Select a setup number with the JOG dial and press the **【ENTER】** key.

```
>2:Store [ALL]
    4
```

- As you press the **【ENTER】** key, message [Completed] will appear about one second to indicate that the storing action (access to memory) by the machine is in progress.

- ④ Press the **【▷】** key again to advance to the next menu item.

```
>3:Recall [ALL]
    1
```

- If you want to return to the preceding menu item, press the **【◁】** key.
- This menu item is to recall the [ALL] items from the backed-up memory and to set it.
- In this example the bottom row indicates [1] denoting that the setup data of No. 1 is to be recalled from the backed-up memory.

- ⑤ Press the **【ENTER】** key to execute the menu item.

```
Completed
```

- Message [Completed] appears on the bottom row for about one second, indicating that the setup data of No. 1 is recalled from the backed-up memory.

- ⑥ To escape from the setup menu, press the **【SHIFT】** + **【SETUP】** keys or the **【ESC】** key.

```
0.00A 5.00V 0.0W
-- RSET 5000.Ω H --
```

- The setup menu mode terminates and the original menu resumes.

3.5.9 Configuration

As you press the **【SHIFT】** + **【R SET】** (CONFIG) keys, the configuration menu will appear. The menu allows you to select the items as shown below. As you press the **【▷】** key, selection advances to the subsequent item; as you press the **【◁】** key, selection return to the preceding item.

The menu structure is hierarchical. To advance to a lower level menu, press the **【ENTER】** key; to return to an upper level menu, press the **【ESC】** key.

To escape from the configuration menu mode and return to the original display, press the **【SHIFT】** + **【R SET】** (CONFIG) keys again or the **【ESC】** key.

You can select settings of menu items with the the JOG dial. Of menu items [10:] through [13:], you can adjust the settings with the SHUTTLE dial also.

Structure and functions of configuration menu

Configuration

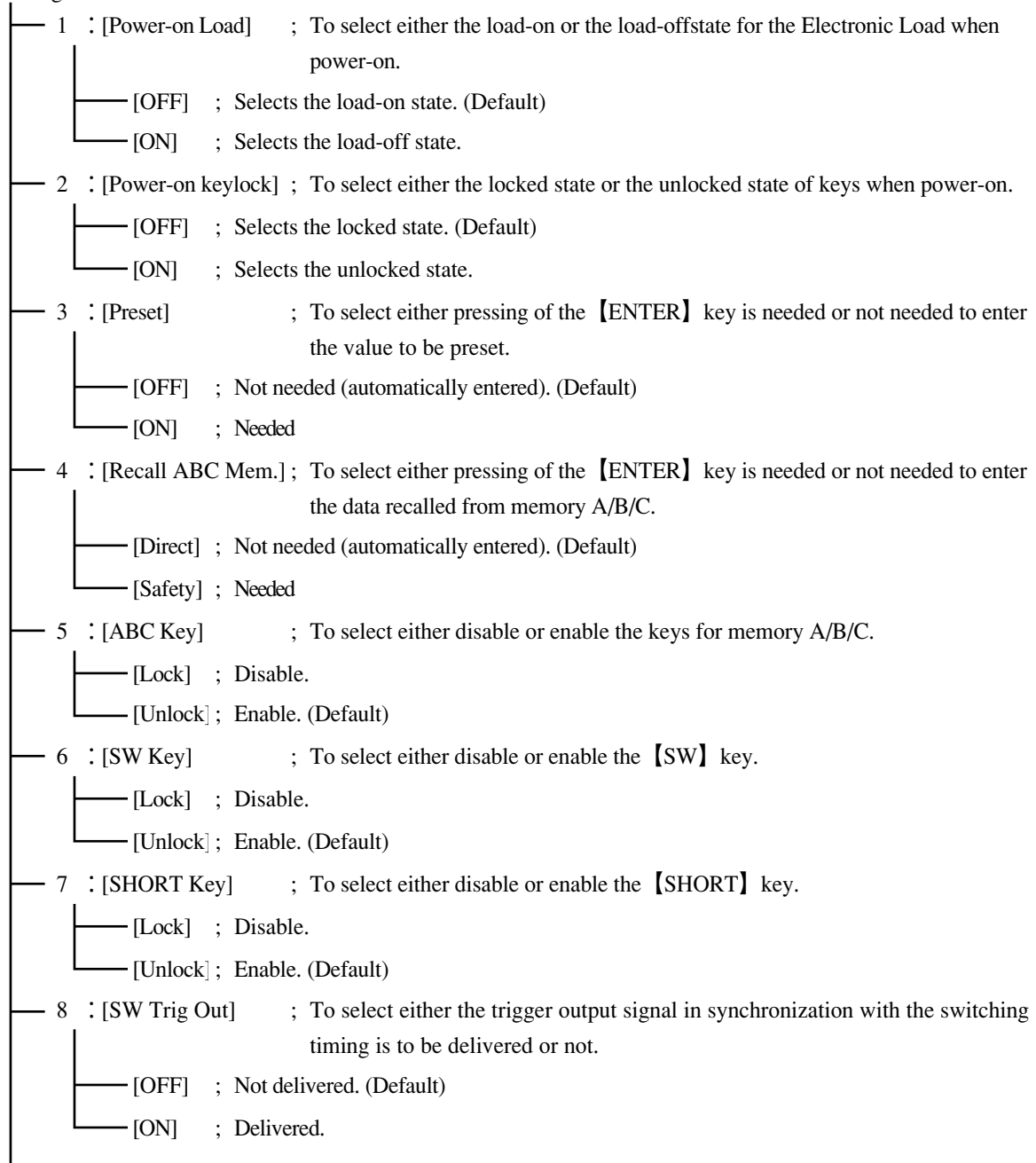

- 9 : [Interface] ; To select interface environments.
 - 1 : [GPIB Address] ; To set GPIB address. (Default: Address 1)
 - 2 : [Power-on SRQ] ; To enable or disable SRQ when power on.
 - [Enable]
 - [Disable] (Default)
 - 3 : [MCB Address] ; To set MCB address. (Default: address 15)
 - 4 : [RS-232C Speed] ; To select a baud rate.
 - [9600 bps] (Default)
 - [4800 bps]
 - [2400 bps]
 - [1200 bps]
 - 5 : [RS-232C Data bit] ; To select a data bit size.
 - [8 bit] (Default)
 - [7 bit]
 - 6 : [RS-232C Stop bit] ; To select a stop bit size.
 - [1 bit]
 - [1.5 bit]
 - [2 bit] (Default)
 - 7 : [RS-232C Parity] ; To select a parity bit type.
 - [None] (Default)
 - [Odd]
 - [Even]
- 10 : [Resolution (I)] ; To define the current resolution (increment or decrement per click of JOG dial). (Default: 0.010A)
- 11 : [Resolution (1/R)] ; To define the conductance resolution (increment or decrement per click of JOG dial). (Default: 0.010 siemens)
- 12 : [Resolution (V)] ; To define the voltage resolution (increment or decrement per click of JOG dial). (Default: 0.010V)
- 13 : [Resolution (P)] ; To define the power resolution (increment or decrement per click of JOG dial). (Default: 0.100W)
- 14 : [Parallel Ope.] ; To define the number of Electronic Load to be operated in parallel. (Default: 1)
- 16 : [Calibration]

3.5.10 Alarm Function

[1] Alarm actions and messages

The Electronic Load provides alarm actions (protective actions) and displays alarm messages (on the bottom row of the display) as shown in Table 3.5-5.

Table 3.5-5

Type	Cause	Action	Message
Reverse voltage	The voltage applied to the input terminal is in the reverse polarity.	Sounds the buzzer.	*ALARM* REVERSE
Over-voltage	The voltage applied to the input terminal is higher than 125V DC.	Turns into the load-off state, and sounds the buzzer. The alarm output terminal becomes the Low level.	*ALARM* OVER-V
Overheat	The internal power unit temperature has becomes higher than approximately 100°C	Turns into the load-off state, and sounds the buzzer. The alarm output terminal becomes the Low level.	*ALARM* OHP
Fuse blown out	The internal power unit fuse has blown out.	Turns into the load-off state and sounds the buzzer. The alarm output terminal becomes the Low level.	*ALARM* FB1 *ALARM* FB2 *ALARM* FB3 (One of the above is displayed.)
Over-current	The current fed to current the Load is higher than approximately 105% of the rated current.	Limits the current within the rated current and sounds the buzzer.	*ALARM* OCP
Alarm detected	An external alarm signal is applied via the external control connector.	Turns into the load-off state. The alarm output terminal becomes the Low level.	*ALARM*EXT

NOTE

- The alarm output terminal is at the external control connector (J2) on the rear panel.
- If there are two or more alarms, the one which has been detected latest appears on the display.
- When Over voltage, Overheat, Fuse blown out or Alarm detected appears two times or more continuously or the alarm is reset at the cause of the alarm still exist, the PSET value is at 0.0W.
- Load-on state by contact signal at operates, when Over-voltage, Overheat, Fuse blown out or Alarm detected, however, load-lamp does not turn off the light even if it becomes Load-off.

[2] To reset from alarm

To reset from an alarm status, press the **[SHIFT] + [ESC]** (ERR RESET) key. If the cause of the alarm still exist, however, the alarm will resume,

NOTE

- The overcurrent alarm will automatically reset when the cause of the alarm is removed.
- When message [**ALARM* EXT*] has appeared indicating that an external alarm is applied, remove the alarm status of the external device which is sending the alarm signal via the external control connector (J1) and then rest the Electronic Load from the alarm status.
- The alarm output terminal is at the external control connector (J2) on the rear panel. The alarm signal delivered through this terminal is as shown in Figure 3.5-10.
- When the alarm is reset after Over-voltage, Overheat, Fuse blown out or Alarm detected appears two times or more continuously, the PSET value is at 0.0W.

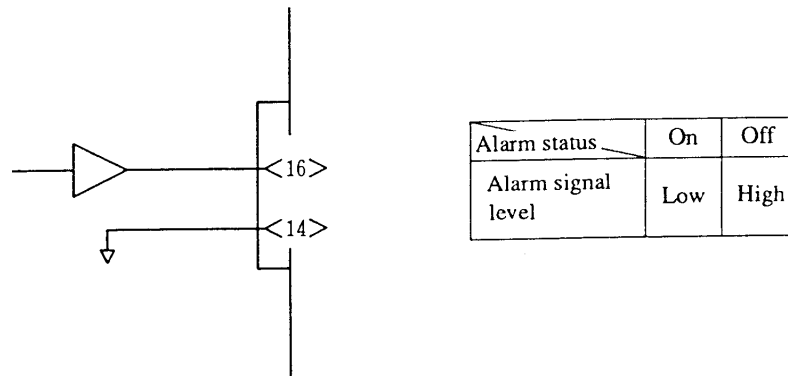

Figure 3.5-10

3.5.11 Short Function

If you press the **[SHIFT] + [SW]** (SHORT) keys, the Electronic Loadies automatically set to the maximum current (if it is in the C.C mode) or to the minimum resistance (if it is in the C.R mode). When in this state, if the DC input terminal voltage becomes lower than 1.5V, the Short signal output terminals of the external control connenctor (J2) on the rear panel will deliver a 'make' contact signal. You may use this contact signal to drive a larger relay to short the DC input terminals as shown in Figure 3.5-11.

The operating input range of the Electronic Load in 1.5V or higher. You may use the Short function, for example, to test the droop characteristics of a regulated DC power supply at a range lower than 1.5V.

Equipment to be tested PLZ-3W Series (regulated DC power supply) Electronic Load.

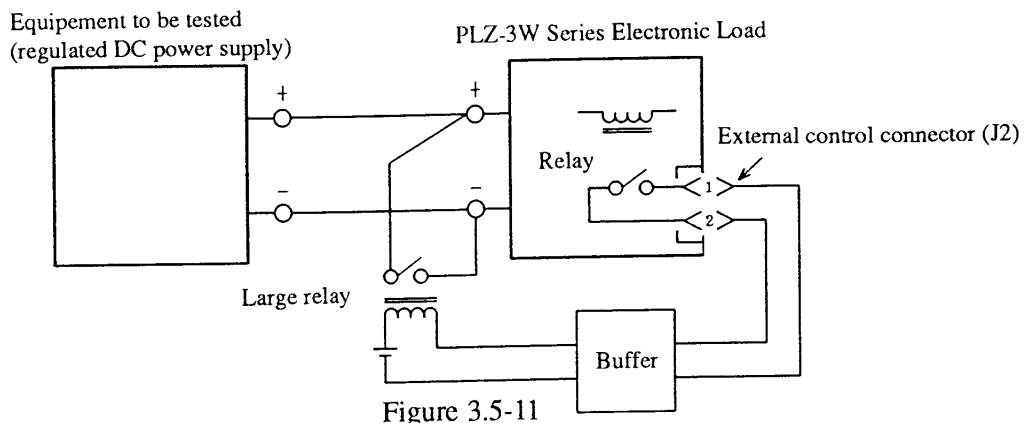

Figure 3.5-11

Caution

- To drive the external larger relay, be sure to use a buffer.
- The ratings of the contact signal delivered between terminals ① and ② of connector J2 are as follows;

Maximum on/off current	: 500mA
Voltage rating	: 60VDC

Example: To use the Short function

This example explains how to use the Short function (except the use of the Short output signal) assuming the following conditions:

- (1) To set the I SET value at 5 A.
- (2) To drive the Electronic Load into the load-on state and feed to it 5 V, 5 A.
- (3) To drive it into the Short state.

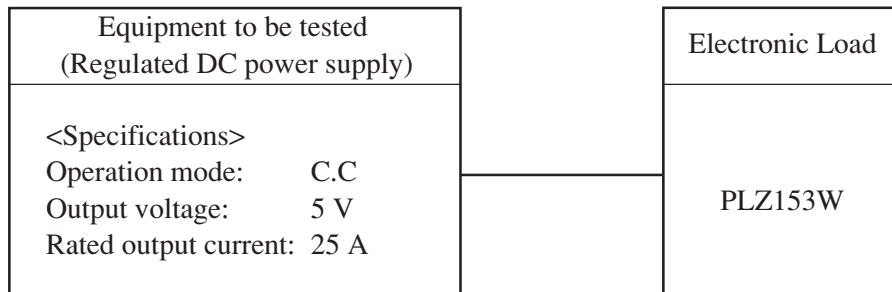

Figure 3.5-12

① When in the load-on state, press the **[SHIFT] + [SW] (SHORT)** keys to enable the Short mode.

```

30.00A   1.20V   36.0W
CC << SHORT >>
    
```

- Message [**<<SHORT>>**] appears on the bottom C.C **<< SHORT >>** row, indicating the Short mode is enabled.
- Data [30.00A] at the left hand end on the top row indicates that the current limit of the regulated DC power supply is at point "A" (30.00 A) on the droop curve shown in Figure 3.5-13. Data [1.20V] also indicates a value under the similar conditions. In this case the I SET value is at 30.00 A.

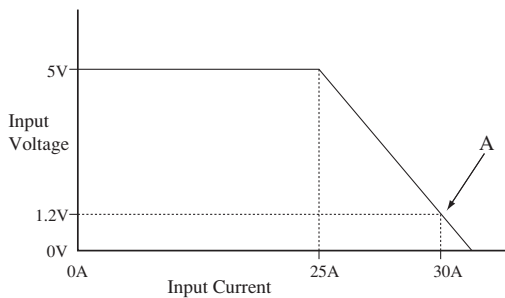

Figure 3.5-13

② Press the **[SHIFT] + [SW] (SHORT)** keys again to escape from the Short mode.

```

5.00A   5.00V   25.0W
CC ISET 5.00A   H
    
```

- The original display resumes indicating the escape from the Short mode.
- Each time as you press the **[SHIFT] + [SW] (SHORT)** keys, the Electronic Load is driven into or released from the Short state.

3.6 Sequence Operation

The sequence mode of operation is such that the Electronic Load automatically renders a programmed sequence of loading effects with programmed parameters of the I SET, R SET, V SET, P SET values, etc. By using the sequence mode of operation, you can let the Electronic Load draw a current in waveforms as you may require.

- NOTE** • For the sequence mode of operation, you can program only the values of the same type (for example, the I SET values alone when in the C.C mode).

Examples of sequence operation

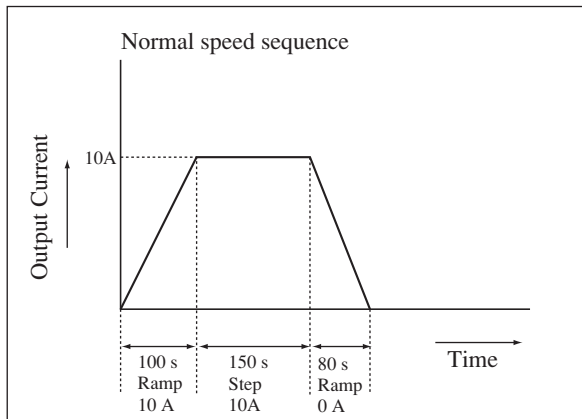

Figure 3.6-1

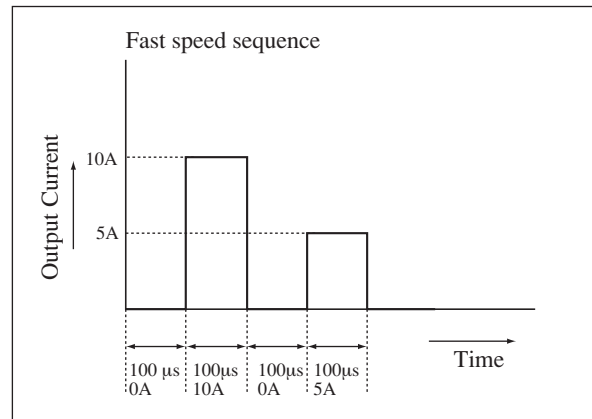

Figure 3.6-2

3.6.1 Description of Sequence Operation

[1] Types of sequence operation

■ General description

The types of sequence operation are classified by the execution speeds and modes as shown in Figure 3.6-3.

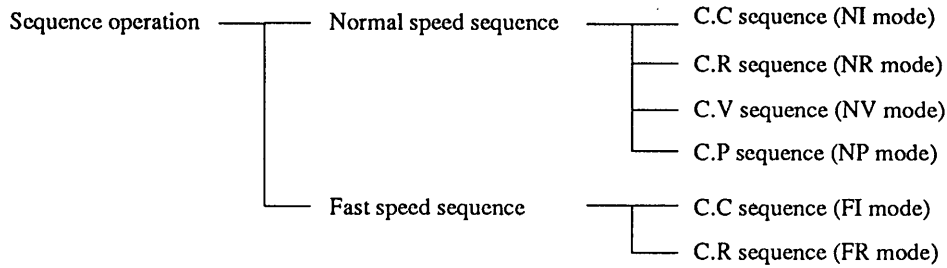

Figure 3.6-3

Individual modes are as described below.

- NI mode : For sequence operation of I SET values primarily, at the Normal sequence speed.
- NR mode : For sequence operation of R SET values primarily, at the Normal sequence speed.
- NV mode : For sequence operation of V SET values primarily, at the Normal sequence speed.
- NP mode : For sequence operation of P SET values primarily, at the Normal sequence speed.
- FI mode : For sequence operation of I SET values primarily, at the Fast sequence speed.
- FR mode : For sequence operation of R SET values primarily, at the Fast sequence speed.

■ Comparison between Normal speed sequence and Fast speed sequence

The features of the Normal speed mode and Fast speed mode of sequence operation are compared in Table 3.6-1. The major differences between them are in operation speed, items to be set, the maximum number of steps, availability of pause function, and availability of function to reset from pause by a trigger signal.

Table 3.6-1

	Normal speed mode	Fast speed mode
Items that can be set for steps	I SET value (NI mode) R SET value (NR mode) V SET value (NV mode) P SET value (NP mode) Trigger output Load ON/OFF SHORT function Step transition or ramp transition Pause function	I SET value (FI mode) R SET value (FR mode) Trigger output
Execution time of steps	Execution time can be set for each step (range is fixed for each sequence operation) 1. Millisecond range (1 ms - 9999 ms) 2. Second range (1 s - 999.9 s) 3. Minute range (1 s - 999 min 59 s) 4. Hour range (1 min - 999 h 59 min)	0.1 ms - 100 ms
Reset from pause by trigger input	Available	Unavailable
Maximum number of steps	256 (*1)	1024 (*1)
Number of loops (*2)	1-9998, and infinitive (by specifying 9999)	1-9998, and infinitive (by specifying 9999)
Number of programs	16	16
Number of sequences	8	8

*1: The sum of the steps of all programs. For example, in the normal speed mode, if one program occupies 255 steps, only one step for only one other program is left.

*2: The number of repetitions of the program.

NOTE

- When in the NI or FI mode, if the programmed execution time is shorter than the T_r T_f time setting, the actual current may not reach the programmed value.
- At the fast speed sequence operation mode when two programs of one step or two steps chained each other are executed at high speed, normal processing may not be done by the occurrence of a reception error for a message through RS-232C. Change programming of the sequence or control the Electronic Load via GPIB.

[2] Steps, programs, and Sequences

The relationships among steps, programs and sequences are as shown in Figure 3.6-3.

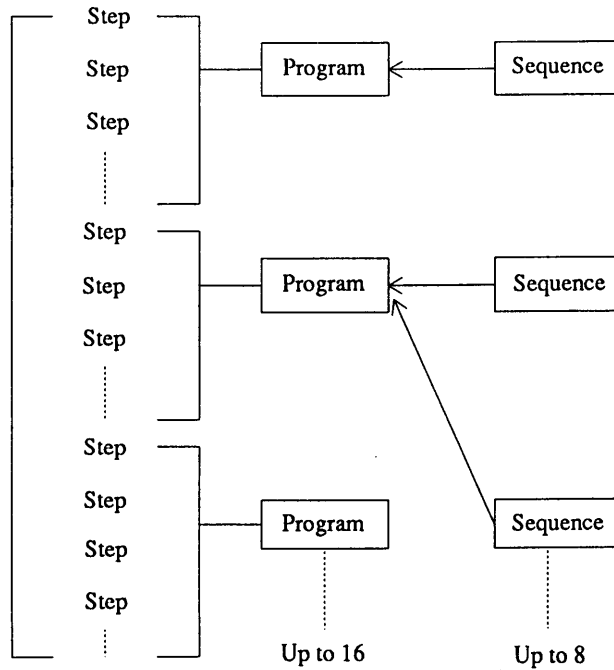

Figure 3.6-3

■ Steps

The steps define the setting items indicated in Table 3.6-1. The steps are the most basic parameters of sequence operation.

■ Programs

Each program consists of steps. Up to 256 steps (1024 steps when in FI or FR mode) can be assigned to up to 16 programs. The programs are the basic patterns for sequence operation. Even a single program can be executed.

■ Sequences

The sequences define what programs should be executed in what manner.

A sequence can specify to execute one of up to 16 programs, by specifying the following:

- ① Program number
- ② Number of loops The number of repetitions of the specified program.
- ③ Step execution time Time span to execute the step.
- ④ Chain sequence To specify the next sequence which should follow this sequence.
- ⑤ End program To define the end of the sequence.

[3] Sequence Files

The structure of the sequence files are as shown in Figure 3.6-4. Up to one sequence files can be stored on the internal back-up memory.

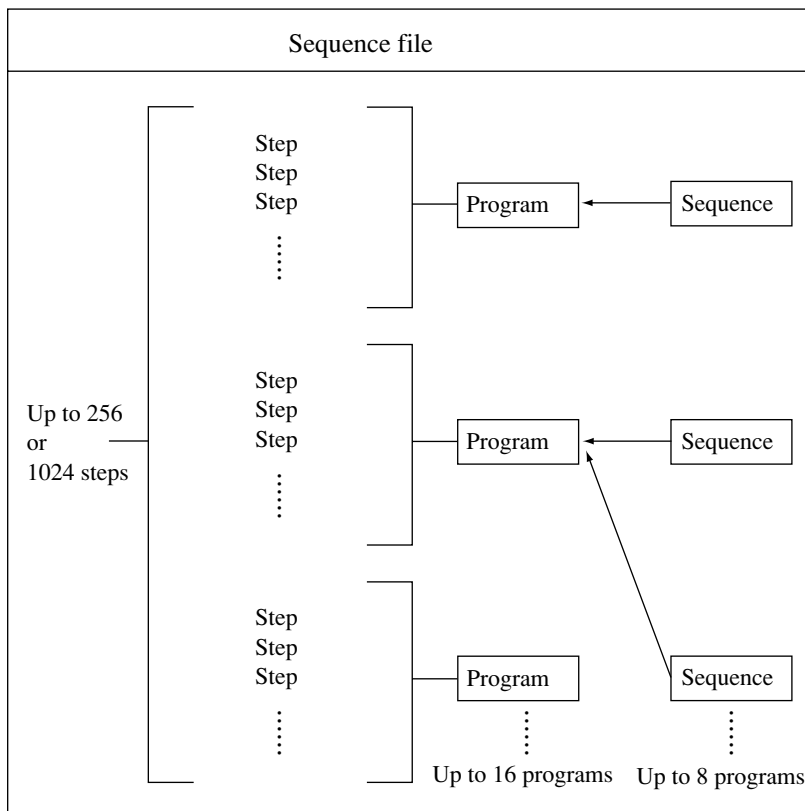

Figure 3.6-4

NOTE

- You can specify either the Normal speed sequence or the Fast speed sequence in the unit of sequence file. You can do this when creating a new sequence by executing menu [3: New] which is a lower level menu of menu [1: Edit].

[4] Description of Sequence Operation Execution

For sequence operation, specify the below-mentioned items in addition to the operation parameters (I SET value, etc.) for each step (refer to Table 3.6-1).

- (1) Output transition (step transition or ramp transition)
- (2) Trigger output
- (3) Pause, and release from pause by trigger input
- (4) Load-on or load-off
- (5) SHORT function

Execution of sequence operation related to the above items (1), (2) and (3) are explained below.

■ Output transition

Step transition: The step transition is that the output changes with a steep angle, as shown in Figure 3.6-5 for example.

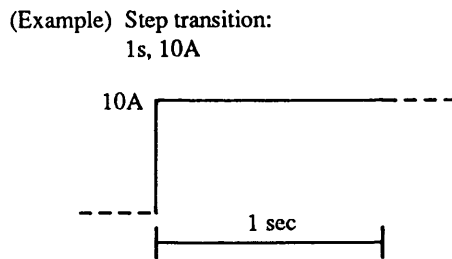

Figure 3.6-5

Ramp transition: The ramp transition is that the output changes with a slant angle, as shown in Figure 3.6-6 for example.

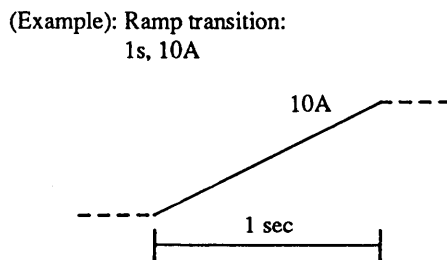

Figure 3.6-6

■ Trigger output

This parameter is for delivering a trigger pulse output via the TRIG OUT terminal on the front sub-panel, each pulse representing an event of program step change.

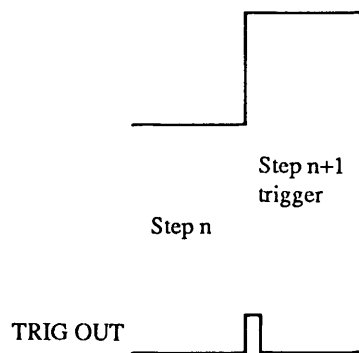

Figure 3.6-7

■ Pause, and reset from pause by trigger input (for NI, NR, NV and NP modes only)

You can pause the sequence operation by pressing the [PAUSE] key.

The sequence operation resumes as you press the [PAUSE] key again or as a trigger input is applied via the TRIG IN terminal of the external control connector.

- Pause by pressing the [PAUSE] key, and reset from pause by trigger input

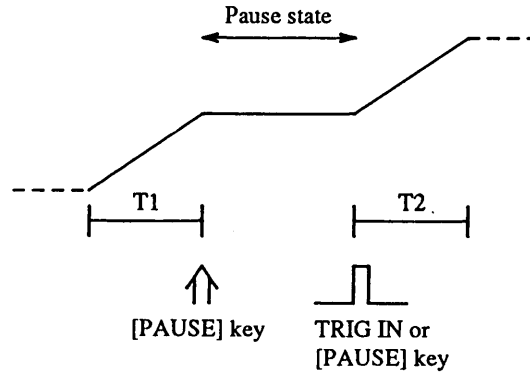

Figure 3.6-8

- Pause by programming, and reset from pause by trigger input signal

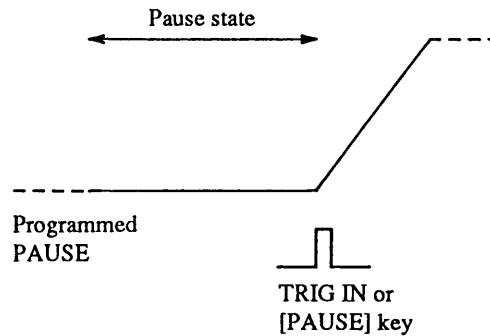

Figure 3.6-9

NOTE

- For the electrical specifications of the TRIG IN terminal, refer to Section 7.1 "Electrical Specifications."

■ Example of sequence operation (Normal speed mode)

An example of sequence operation is introduced below to show the functions of steps, programs, and sequences. In this example, as sequence 1 is executed, the Electronic Load performs the sequence operation of a configuration as shown in Table 3.6-10.

- Sequence 1: Execute program 1 once, and chain it to sequence 2.
- Sequence 2: Execute program 2 twice, and chain it to sequence 3.
- Sequence 3: Execute program 3 once, and terminate the operation at the first step of program 16 (end program).

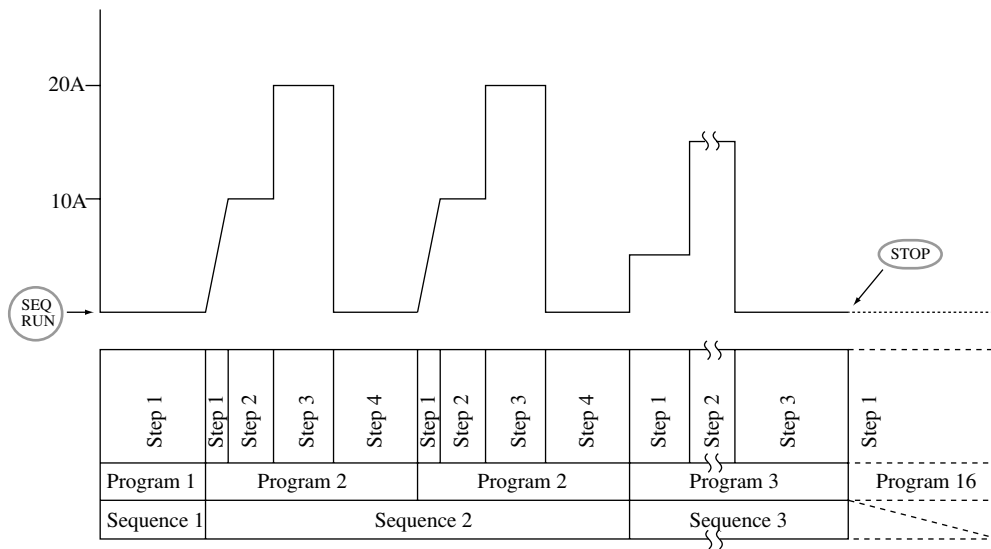

Figure 3.6-10

NOTE

Note on Normal Speed Sequence Executing

- You can specify sequences and programs in any order.
- You cannot chain a program to another sequence which is stored in another file.
- The purpose of the end program is to specify the state to be assumed when the program is over. Of the end program, its first step alone is executed. Therefore, its pause data and time data are meaningless.
- Before entering the end program, a certain time interval (several milliseconds to several tens milliseconds) is necessary.
- When chain operation is specified, the end program is not executed and the operation advances to the sequence number of the destination of chain operation.
- If you hardware-stop the sequence operation by pressing the **【STOP】** key or by other means, the first step of the end program of the currently-executed sequence is executed. If no end program is specified (no end program is specified when [E**] is displayed), the operation terminates at the step which has been under execution when the stop command is given.

Note on Fast Speed Sequence Executing

- When sequence are chained, the final step execution time of a program is not guaranteed. Use great care when using the chained sequence.

3.6.2 Outline of Settings for Sequence Operation

For sequence operation, you must manage sequence files, create and edit sequence parameters, and then execute the sequences. Select the required items following the procedure indicated by menus.

■ Sequence operation menu configuration and functions

Initial sequence menu

- 1 : [Edit] ; Edit menu
 - 1 : [Edit Program] ; To add, modify or delete programs of sequence execution memory.
 - 2 : [Edit Sequence] ; To create or edit sequence parameters of sequence execution memory.
 - 3 : [New] ; To initialize sequence execution memory.
- 2 : [RUN] ; menu ; To run the contents of sequence execution memory.

■ Conceptual diagram of sequence operation

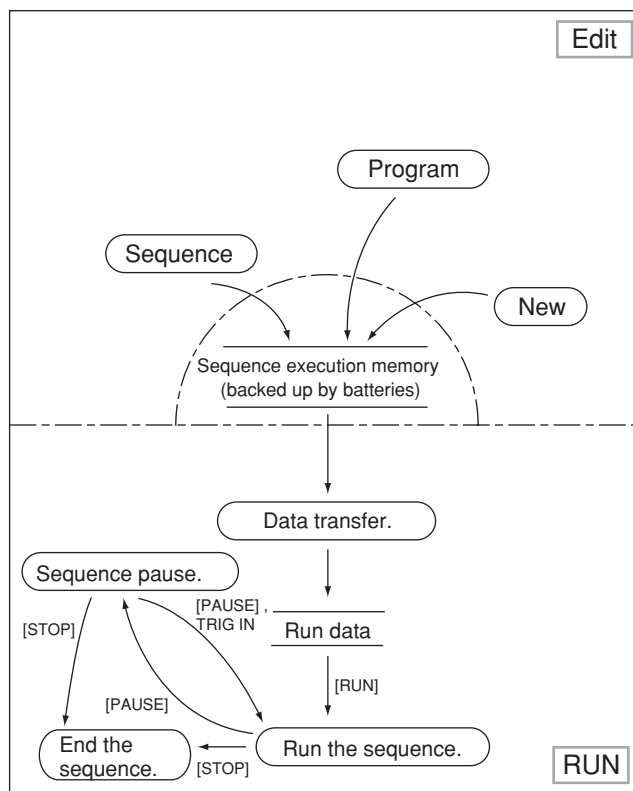

Figure 3.6-11

3.6.3 Sequence Operation Procedure

For sequence operation, it is recommendable to prepare coding sheets which contain the operation parameters you may require. (For samples of coding sheets, refer to Appendix 2. The examples shown there are for the following sequence operation. In the following sequence operation, a regulated DC power supply of 5 V, 20 A is assumed.)

The subsequent Items [1] and [2] introduce examples of procedures for entering onto sequence execution memory the data which has been written on the coding sheets (as shown in Appendix 2) .

[1] To initialize the sequence execution memory

For sequence operation, you must initialize the sequence execution memory first of all. You can create up to eight sequences of the same mode on the sequence execution memory.

■ Examples of procedures for selecting the sequence operation mode and initializing the sequence execution memory

This section introduces the procedures for doing the following from the sequence menu.

- (1) To select the edit menu and then to select the sub-menu to initialize the sequence execution memory,
- (2) To select the NI mode for sequence operation and select the millisecond range for step execution time, and
- (3) To initialize the sequence execution files.

① Press the **【SEQ】** key on the front sub-panel to call out the sequence menu. Select [1: Edit] with the JOG dial or the **【▷】** or **【◁】** key.

```
> 1 :  E d i t
   2 :  R u n
```

- The sequence menu appears.
- Only on the sequence menu, you can select items with the JOG dial.

② Press the **【ENTER】** key. Select [3: New] with the JOG dial or the **【▷】** or **【◁】** key.

```
   2 :  E d i t   S e q u e n c e
> 3 :  N e w
```

- The edit menu appears.
- The bottom row indicates the sub-menu item (for initializing the sequence execution memory in this example).

③ Press the **【ENTER】** key to select the mode for initializing the sequence execution memory.

```
C r e a t e   N e w   S e q u e n c e
   S u r e ?
```

- The message requests you to confirm that you want to initialize the sequence execution memory.

- ④ Press the **【ENTER】** key to confirm that you want to initialize the sequence execution memory.

```
Mode -> NR
Unit : msec
```

- The menu to select sequence modes will appear.
- The top row indicates the sequence mode and the bottom row indicates the range (unit of time) for step duration. In this example, the mode is NR and the range is millisecond.
- You can select the item (sequence mode NI, NR, NV, NP, FI, or FP) indicated at the left of symbol [->] with the JOG dial.
- As you select this item, the mode for the sequence operation is automatically set.

- ⑤ Select the [NI] mode with the JOG dial. With the JOG dial or the **【▷】** or **【◁】** key, move symbol [->] to the position following the [Unit] on the bottom row, and select [msec] with the JOG dial.

```
Mode : NI
Unit -> msec
```

- The [msec] range is selected for the step execution time.
- The selectable ranges (ranges indicated following the [->] symbol) are msec, sec, minute/second, and hour/minute.

- ⑥ Press the **【ENTER】** key to initialize the sequence execution memory (see "Note 1").

```
Completed
```

- As you press the **【ENTER】** key, the sequence execution memory is initialized (see "Note 1").
- If you want to abort initializing the sequence execution memory, press the **【ESC】** key. The original display will resume.
- Message [Complete] will appear for about one second on the display.

▼ At about one second later

```
2 : Edit Sequence
>3 : New
```

- After the initializing procedure is complete, the edit menu will resume.

NOTE

- If you initialize the sequence execution memory, the data existing on the memory will be lost.

[2] To create programs and edit sequences

When you have initialized the sequence execution memory, you are ready to generate programs and edit sequences.

■ Example: To create programs

This section introduces the procedures for the following:

- (1) To create program 1 by specifying one step for the program area and by specifying a transition mode, I SET value, execution time and other items as shown in the example introduced in Appendix 2.
- (2) To create program 2, program 3, and program 16 in a similar manner as above.

First of all, specify the area for program 1.

- ① From the edit menu, select [1: Edit Program]. Then, press the **【ENTER】** key.

```

P r o g r a m : 0 1           : N I
      0 0 0   S t e p       [ T 0 0 0 ]
    
```

- This display allows you to specify a program number.
- [01] of [Program:01] on the top row denotes the program number.
- [000] at the left hand end on the bottom row denotes the number of steps of the program.
- [T000] at the right hand end on the bottom row denotes the total number of steps of all programs.

- ② Specify a program number with the JOG dial and press the **【ENTER】** key.

```

N 0 0 1
  E n d   o f   s t e p
    
```

- This display appears as no program area has been secured yet.

- ③ Press the **【ENTER】** key.

```

N 0 0 1
  > 1 :   M o d i f y
    
```

- A menu of a lower level of the edit menu
- The selectable items are as follows:
 - [1: Modify] To modify the parameter of each step of program.
 - [2: Insert] To insert a program area (a step).
 - [3: Delete] To delete a program area (a step).
- To edit a new program, select [2: Insert] to secure a program area.

- ④ Select [2: Insert] with the JOG dial or with the [▷] or [◁] key and press the [ENTER] key.

```

Insert : 0 0 1
How many Steps?
    
```

- This display allows you to specify the maximum number of steps for program 1.
- Cursor (1) blinks, indicating the number of steps.

- ⑤ Specify the number of steps (1 in this example) with the JOG dial and press the [ENTER] key.

```

N 0 0 1 S 0 . 0 0 A
> 2 : Insert
    
```

- Message [Completed] appears about one second and then this display appears indicating that the number of steps for program 1 has been set at 1.
- If you want to change the number of steps again, repeat the procedure starting by [2: Insert].

By the above procedure, the number of steps for program 1 has been set to 1. Now, proceed to set the transition mode, I SET value, execution time and other parameters.

- ⑥ Select [1: Modify] with the JOG dial or the [▷] or [◁] key.

```

N 0 0 1 S 0 . 0 0 A
> 1 : Modify
    
```

- ⑦ Press the [ENTER] key.

```

N 0 0 1 S 0 . 0 0 A
      1 m s           . L . .
    
```

- The program edit display appears. This display allows you to specify parameters for the step.

The parameters which can be edited on this display and the functions of the related keys are explained below.

Format of the program edit display

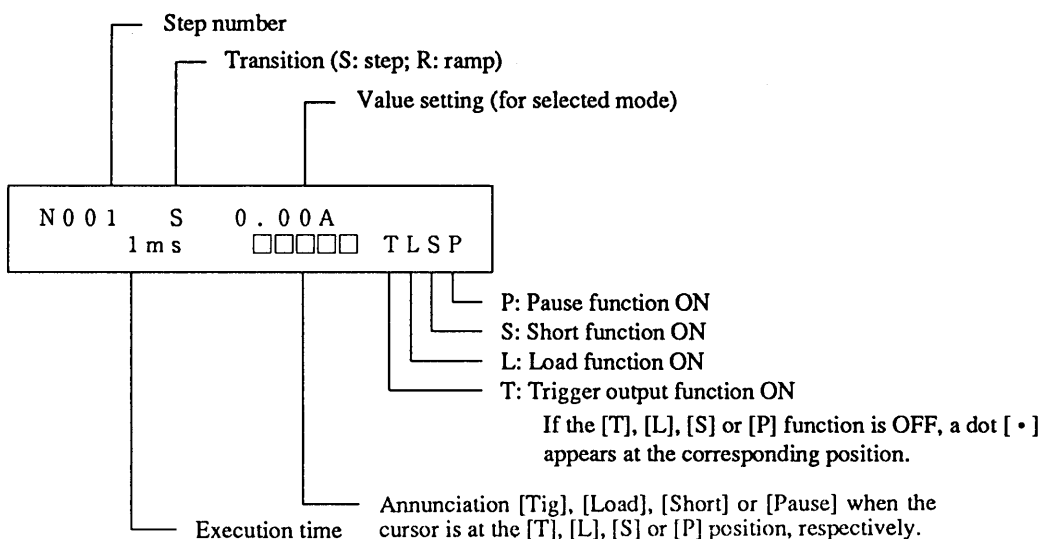

NOTE

- When in the Fast speed sequence mode, the trigger selection alone appears on the bottom row.

■ Functions of the related keys

- You can ascend the step number to a larger number by pressing the **[SHIFT] + [▷]** (△) keys or descend it to a smaller number by pressing the **[SHIFT] + [◁]** (▽) keys.
 - You can select the required items for the parameters (transition, value setting for the selected mode, execution time, [T], [L], [S] and [P]) with the **[▷]** and **[◁]** keys. (This does not apply to the step number.) The cursor blinks on the item you selected. You may use the JOG dial to specify a value.
- ⑧ Move the cursor to the [1ms] position on the bottom row with the **[▽]** key and change it to [50ms] with the JOG dial.

```
N 0 0 1   S   0 . 0 0 A
      5 0 m s           · L . .
```

- To change other parameters, use the JOG dial and **[▷]** and **[◁]** keys.

By the above procedure, the program area for program has been secured and the parameters have been set as per Appendix 2. Now, repeat similar procedures for program 2, program 3, and program 16.

- ⑨ Press the **[ESC]** key thrice to return to the program number entry display of ⑨.

```
P r o g r a m : 0 1           : N I
      0 0 1   S t e p   [ T 0 0 1 ]
```

- The program number entry display of ⑨ appears.

- ⑩ Edit step 01 of program 2 by repeating the procedure of ① through ⑧.

```
N 0 0 1   R   1 0 . 0 0 A
      1 0 m s           T L . .
```

- This display is an example of edit for step 01 of program 2.

- ⑪ Press the **[SHIFT] + [▷]** (△) keys and edit step 02 of program 2.

```
N 0 0 2   S   1 0 . 0 0 A
      2 0 m s           · L . .
```

- This display is an example of edit for step 02 of program 2.

NOTE • If you want to view or modify the data of the preceding step, use the **[SHIFT] + [◁]** (▽) keys.

- ⑫ Press the **[SHIFT] + [▷]** (△) keys and edit step 03 of program 2.

```
N 0 0 3   S   2 0 . 0 0 A
      3 0 m s           · L . .
```

- This display is an example of edit for step 03 of program 2.

- ⑬ Press the **[SHIFT] + [▷]** (△) keys and edit step 04 of program 2.

```
N 0 0 4   S   0 . 0 0 A
      4 0 m s           · L . .
```

- This display is an example of edit for step 04 of program 2.

- ⑭ Edit step 01 of program 3 by executing the procedure of ⑨ and that of ① through ⑧.

```
N 0 0 1   S   5. 0 0 A
      3 0 m s           . L . .
```

- This display is an example of edit for step 01 of program 3.

- ⑮ Press the **【SHIFT】** + **【▷】** (△) keys and edit step 02 of program 3.

```
N 0 0 2   S  1 5. 0 0 A
      8 0 0 0 m s       . L . .
```

- This display is an example of edit for step 02 of program 3.

- ⑯ Press the **【SHIFT】** + **【▷】** (△) keys and edit step 03 of program 3.

```
N 0 0 3   S   0. 0 0 A
      5 0 m s           . L . .
```

- This display is an example of edit for step 3 of program 3.

- ⑰ Edit step 01 of program 16 by executing the procedure of ⑨ and that of ① through ⑧.

```
N 0 0 1   S   0. 0 0 A
      1 m s             . . . .
```

- This display is an example of edit for step 01 of program 16.

- ⑱ Press the **【ESC】** key five times to return to the initial menu of sequence operation.

```
> 1 :  E d i t
   2 :  R u n
```

■ Example: To check, modify, add or delete step data

This section introduces the procedures for the following:

- (1) To check the data of program 1.
- (2) To delete a step.
- (3) To inset a step.

First, proceed as follows to check the step data.

- ① Select [1: Edit Program] from the edit menu and press the **【ENTER】** key.

```

P r o g r a m : 0 1           : N I
      0 0 1   S t e p       [ T 0 0 9 ]
  
```

- You can specify with the JOG dial the program number.

- ② Specify a program number ("01" in this example) with the JOG dial and press the **【ENTER】** key.

```

N 0 0 1   S   0 . 0 0 A
      5 0 m s           . . . .
  
```

- The display allows you to view the data of the program.
- You can check the data of steps by changing the step numbers with the JOG dial or **【▷】** and **【◁】** keys.

- ③ press the **【ENTER】** key.

```

N 0 0 1   R   1 0 . 0 0 A
      > 1 : M o d i f y
  
```

- The menu appears.
- Press the **【ENTER】** key to select[Modify] to modify the data of the step. The modifying procedure is the same that of ⑥ and subsequent procedure of the preceding programming example.

Next, proceed as follows to delete a step.

- ④ Select [3: Delete] with the JOG dial or **【▷】** or **【◁】** key. Press the **【ENTER】** key.

```

D e l e t e : 0 0 1
      H o w   m a n y   S t e p s ?   1
  
```

- The number ([001] in this example) that follows [Delete] is the head number of the steps to be deleted. You can change the number with the **【SHIFT】 + 【▷】** (△)keys or with the **【SHIFT】 + 【◁】** (▽)keys.
- The number indicated by the cursor denotes the number of steps to be deleted starting by the head number.

⑤ Select 1 with the JOG dial. Press the **【ENTER】** key.

```

C o m p l e t e d

```

▼ At about one second later

```

N 0 0 1
  > 3 : D e l e t e

```

- In this example, step 1 has been deleted.

Next, proceed as follows to insert a step.

⑥ Select [2: Insert]. Press the **【ENTER】** key.

```

I n s e r t : 0 0 1
  H o w   m a n y   S t e p s ?   1

```

- This step allows you to insert a step.
- The number ([001] in this example) that follows [Insert] is the head number of the steps to be inserted. You can change the number with the **【SHIFT】 + 【▷】** (△) keys or with the **【SHIFT】 + 【◁】** (▽) keys.
- The number indicated by the cursor denotes the number of steps to be inserted starting by the head number.

With the JOG dial, select the number (1 in this example) of steps to be inserted. Press the **【ENTER】** key.

```

C o m p l e t e d

```

▼ At about one second later

```

N 0 0 1   S   0 . 0 0 A
  > 2 :   I n s e r t

```

- In this example, step 1 has been inserted.
- The inserted step data is undefined.
- Return to the edit procedure for step 01 of program 1 and edit it referring to the coding sheet.

Example: To edit sequences

This section introduces a procedure to edit the setting data (the program number, the number of loops (the number of repetitions of the program), the chain destination sequence number, and the end program number) for each of the sequences of sequences numbers 1 through 3, as per data assumed in Appendix 2.

- ① Select [1: Edit] on the initial sequence menu and press the **【ENTER】** key to call out the edit menu. Select [2: Edit Sequence] on the edit menu and press the **【ENTER】** key.

```
Sequence : 1           : N I
P 0 1 , L 0 0 0 0 , C * , E * *
```

- The sequence display appears allowing you to check the data of the sequence.
- You can check the data of other sequences (sequence numbers 1 through 8) also, by selecting them with the **【▷】** and **【◁】** keys or the JOG dial.

- ② Press the **【ENTER】** key.

```
P 0 1 , L 0 0 0 0 ,
C * , E * *
```

- The sequence edit display appears.
- The cursor blinks on (1).
- Select an item with the **【▷】** and **【◁】** keys, and enter a value with the JOG dial.
- To escape from the edit mode, press the **【ESC】** key. The sequence display will resume.

The format of the sequence edit display is as follows:

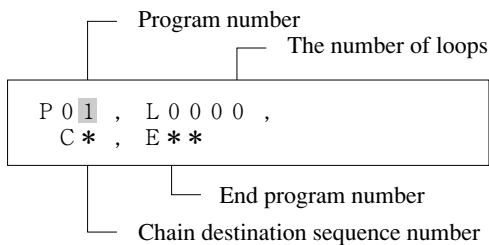

NOTE

- The asterisk "*" of the chain destination sequence number and end program number means that the end program is not executed.

- ③ With the JOG dial or with the **【▷】** and **【◁】** keys, edit the program number, the number of loops, the chain destination sequence number, and the end program number as shown below as per data assumed in Appendix 2.

```
P 0 1 , L 0 0 0 1 ,
C 2 , E 1 6
```

- This display is an example of edit for C2, E16 sequence 1.

- ④ Press the **【ESC】** key to return to the display of ①. Select the next sequence number with the JOG dial and press the **【ENTER】** key to edit the next sequence.

```
P 0 2 ,   L 0 0 0 2 ,
C 3 ,   E 1 6
```

- This display is for edit of sequence 2.
- This sequence is chained, after repeating the program 2 twice, to the subsequent sequent sequence (sequence 3).

```
P 0 3 ,   L 0 0 0 1 ,
C * ,   E 1 6
```

- This display is for edit of sequence 3.
- This sequence is to execute program 1 once and then to execute step 1 of the end program (program 16). It is not chained.

- ⑤ Press the **【ESC】** key twice to return to the edit menu.

```
1 :   E d i t   P r o g r a m
> 2 :   E d i t   S e q u e n c e
```

- End the sequence edit procedure.

[3] To run, end, or pause a sequence or a program

■ Example: To run a program

This section introduces a procedure to run a specified program once.

- ① Select [1: Edit] on the initial sequence menu and press the **【ENTER】** key to call out the edit menu. Select [1: Edit Program] on the edit menu and Press the **【ENTER】** key.

```

Program : 03           : N I
          003 Step    [T009]
    
```

- Specify a program number with the JOG or **【▶】** and **【◀】** keys. In this example, program number 3 is specified.

- ② Press the **【RUN】** key to run the program.

```

15.00A   5.00A   75.0W
CC S3, P03, L0000, 0002
    
```

- This display appears when the program.

■ Example: To run a sequence

This section introduces a procedure to execute a specified sequence once.

- ① Select [2: Run] on the initial sequence menu and press the **【ENTER】** key.

```

Sequence : 1           : N I
          P01, L0001, C2, E16
    
```

- The sequence display appears.
- Specify a sequence number ([01] in this example) with the JOG dial or **【▶】** and **【◀】** keys.
- This menu will directly appear if you press the **【RUN】** key when the initial sequence menu is displayed.

- ② Press the **【RUN】** key to run the sequence.

```

15.00A   5.00V   75.0W
CC S3, P03, L0000, 0002
    
```

- This display appears when the sequence is running.
- [S3] blinks to indicate that the sequence is running.

Format of the sequence run display

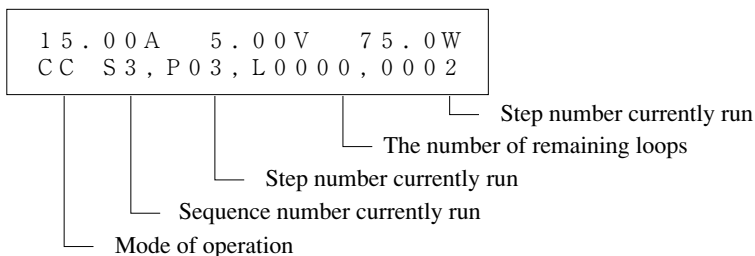

NOTE

- The sequence number blinks when the sequence is running. When in pause, it is indicated steadily.

You can pause or stop the running sequence with the **【PAUSE】** or **【STOP】** key as follows:

- ③ To pause the running sequence, press the **【PAUSE】** key.

```
15.00A   5.00V   75.0W
CC S3, P03, L0000, 0002
```

- The sequence is paused and the display is frozen.
- [S3] changes from blinking to steady indication.
- This function is not applicable to the Fast speed sequence.

- ④ To release the sequence from the paused state, press the **【PAUSE】** key again.

```
15.00A   5.00V   75.0W
CC S3, P03, L0000, 0002
```

- The sequence resumes running and [S3] blinking.

- ⑤ To stop the running sequence, press the **【STOP】** key.

```
Sequence: 1           : NI
P01, L0001, C2, E16
```

- The sequence operation terminates and the sequence display resumes.

NOTE

- The command entered with the **【PAUSE】** key may take time before it is accepted.
- After the sequence is released from the paused state, it executes the data for the remaining period of the step at which it was paused, and then advances to the next step.
- If you press the **【RUN】** key when in a state before entering the sequence mode, the sequence display (that shown in paragraph ①) resumes.

3.7 External Control (Remote Control)

The PLZ-3W Series Electronic Load can be controlled or read (status reading) via the external control connector J1 or J2 on the rear panel.

Connectors J1 and J2 are standard MIL-type 16-pin connectors. Lock levers for the connectors are provided on the mainframe, allowing you to securely lock the connectors or easily disconnect them. Connector J1 is primarily for output signals and J2 for control input signals.

When using the external control cable J1 and J2 there may be an increased sensitivity to interfering RF fields. To minimize any such effect, fit two ferrite sleeves to the cable to the connectors, with a characteristic impedance of approximately 250Ω at 100MHz.

The pin assignment of J1 and J2 are as shown in Table 3.7-1.

Pin No.	J1	J2
①	NC	Short output (+)
②	NC	Short output (-)
③	Trigger output signal (+)	Trigger input signal (+)
④	Trigger output signal (-)	Trigger input signal (-) , digital common line
⑤	Load-on/off monitor output (+)	Load-on/off input (+)
⑥	Load-on/off monitor output (-)	Load-on/off input (-)
⑦	NC	Voltage signal for CC/CR remote control
⑧	Analog common line	Analog common line
⑨	Slave output	Slave input
⑩	Current SUM input	Current SUM output
⑪	NC	Resistance signal for remote control (+)
⑫	NC	Resistance signal for remote control (-)
⑬	NC	Voltage signal for CP remote control
⑭	Digital common line	Alarm output (-)
⑮	NC	Range select signal
⑯	Alarm input	Alarm output (+)

NOTE

- The trigger signal output pins are connected in parallel to the TRIG OUT terminals of the front sub-panel.

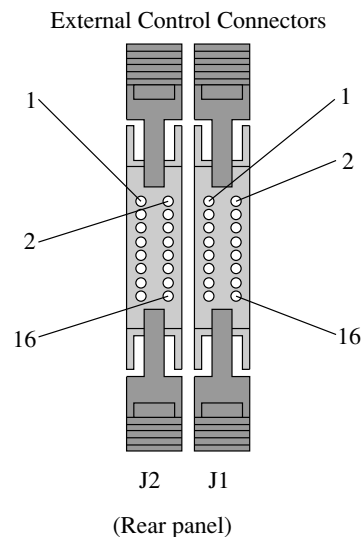

Figure 3.7-1

For the connectors, use the ones which accompany the Electronic Load or ones shown in Table 3.7-2.

Table 3.7-2

Manufacturer	Model	Remarks
OMRON	XG5M-1632 or XG5M-1635 XG55-0801 (two)	For discrete wires
OMRON	XG4M-1630 XG4T-1604	For flat cables
KEL	6200-016-601	For flat cables

Caution

- Be sure to provide strain relief when using a flat cable.
- Be sure to use the designated press tools when connecting discrete wires or flat cables. Observe the instructions given by the tool manufacturers.
- Before connecting or disconnecting the connectors, make it double sure that the POWER switch is turned OFF.

3.7.1 Analog Remote Control of C.C mode

[1] Current control with an external voltage signal

With an external voltage signal of 0 to approximately 10 V, you can control the DC input current the Electronic Load draws. The current is proportional to the voltage signal as shown in Figure 3.7-2.

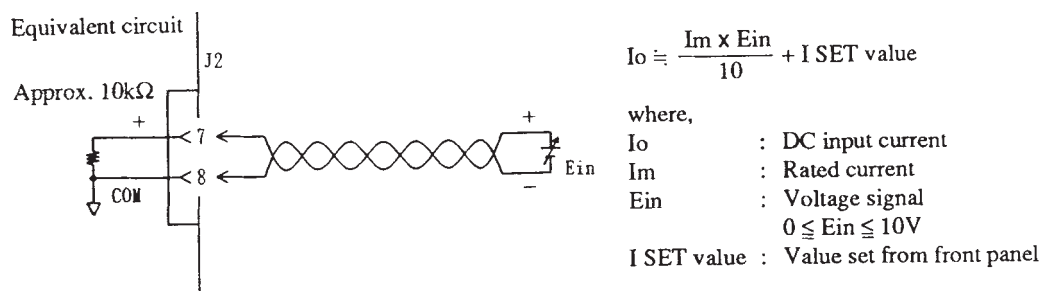

Figure 3.7-2

■ Setup procedure

- 1) Turn OFF the POWER switch on the front panel.
- 2) Connect the voltage signal to pins ⑦ and ⑧ of connector J2 on the rear panel.
- 3) Set SW2 on the rear panel to REM and SW3 to V.
- 4) Turn ON the POWER switch on the front panel.
- 5) Press the **[I SET]** key on the front panel to enable the C.C mode.
- 6) Adjust the offset with the OFS potentiometer on the rear panel so that the current becomes 0 A when the control voltage is 0 V; adjust the full scale with the FS potentiometer on the rear panel so that the current becomes the rated value when the voltage signal is 10 V.
- 7) Press the **[SHIFT] + [STOP]** (KEYLOCK) keys to lock the keys of the Electronic Load.

Caution

- The maximum voltage allowable between pins ⑦ and ⑧ of J2 is ± 11 V. If you apply a voltage higher than this, the Electronic Load may be damaged. If the voltage signal is lower than 0 V or higher than 10 V, the performance may not be within the guaranteed accuracy.
- Pin ⑧ of J2 is internally connected to the "-" load terminal. Be careful not to bring pin ⑧ into contact with other pins.

NOTE

- When in this mode of remote control operation, the current drawn by the Electronic Load is the sum of the remote-controlled current proportional to the voltage signal plus the local-controlled current (I SET value) set from the front panel. On the front panel display, the local-controlled current alone is displayed. Due to this, lest the I SET value should be disturbed, operate the Electronic Load in the keylock state.
- For connection of the remote control signal, use twisted pair wires or a shielded cable to prevent noise. For the external voltage signal, use a stable voltage source of less noise.
- The connector pins used here are the same with those used for remote control of the C.R mode with an external voltage signal. Be sure to select the correct mode.
- If the voltage signal changes AC-wisely, the frequency response bandwidth of the Electronic Load varies depending of the Tr Tf time as shown in Table 3.7-3.

Tr Tf time	Bandwidth (-3 dB)
5 0 μ s	5 . 8 k H z
1 0 0 μ s	2 . 6 k H z
2 0 0 μ s	1 . 5 k H z
1 m s	3 3 0 H z

(Typical values with PLZ1003W)

Table 3.7-3

[2] Current control with an external resistance signal

With an external resistor of 0 to approximately 10 kΩ, you can control the DC input current the Electronic Load draws, with a control setup as shown in Figure 3.7-3. The current is inversely proportional to the external resistor. When the resistance (Rin) is zero, the current (Io) is the maximum (rated current). The control setup is the simplest as compared with those required by other remote control methods.

Equivalent circuit

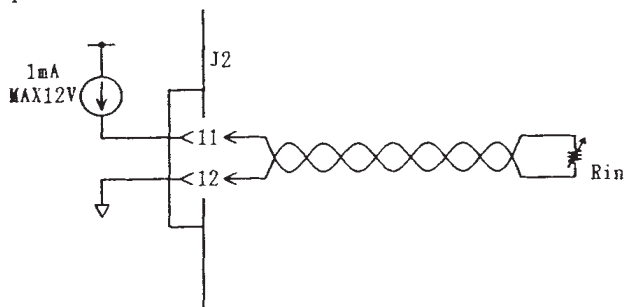

$$I_o \cong I_m \left(1 - \frac{R_{in} (\Omega)}{10000} \right)$$

$$\cong I_m \left(1 - \frac{R_{in} (k\Omega)}{10} \right)$$

where,
 Rin : External resistor
 0 ≤ Rin ≤ 10k approx.
 Im : Rated current
 Io : Input current

Figure 3.7-3

■ Setup procedure

- 1) Be certain that the Electronic Load is in the load-off state. Locally from the front panel, set the I SET value at the maximum value (rated current).
- 2) Turn OFF the POWER switch on the front panel.
- 3) Connect the external resistor to pins ⑪ and ⑫ of connector J2 on the rear panel and set the resistance at the maximum.
- 4) Set SW2 on the rear panel to LOCAL and SW3 to R.
- 5) Turn ON the POWER switch on the front panel.
- 6) Press the [I SET] key on the front panel to enable the C.C mode.
- 7) Press the [SHIFT] + [STOP] (KEYLOCK) keys to lock the keys of the Electronic Load.

NOTE

- For resistor R_{in} , use a quality resistor of good stability against temperature change and aging. If you are using a potentiometer, use a one whose residual resistance is less than 300 ohms. The recommended types of resistors are as follows: Wire wound resistors Metallic film resistors Vernier potentiometers.
- For connection of the resistance signal, use twisted pair wires or a shielded cable to prevent noise.
- If you set the I_{SET} value at a value other than the rated current locally from the front panel, the controllable range of the current may not cover the range claimed in the performance specification. If you set the I_{SET} value at 0 A, the remote control with the resistance signal will fail and the maximum rated current will be fed to the load terminal.
- The same connector pins as used here are used also for remote control in the C.R mode with an external voltage signal. Be sure to select the correct mode.
- The control circuit of the Electronic Load is designed so that the current (I_o) becomes absolutely zero amperes when the external resistance (R_{in}) is $10k\Omega$ --this resistance with some tolerance as shown in Figure 3.7-4.

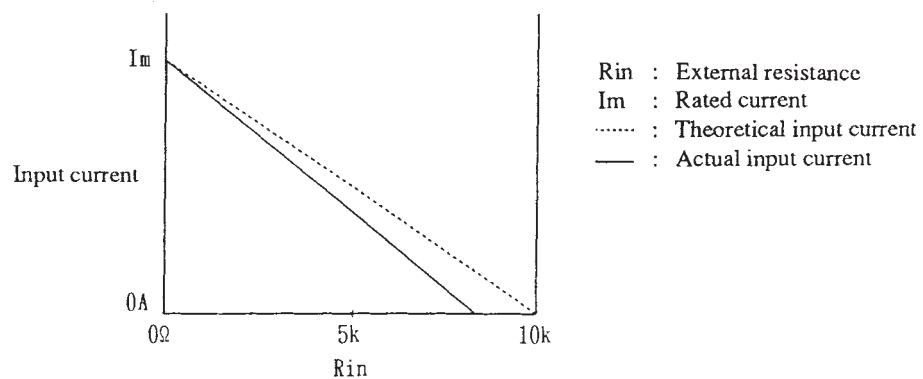

Figure 3.7-4

3.7.2 Analog Remote Control of C.R mode

[1] Resistance control with an external voltage signal

With an external voltage signal of 0 to approximately 10 V, you can control the resistance the Electronic Load exhibits. The resistance is proportional to the voltage signal as shown in Figure 3.7-5.

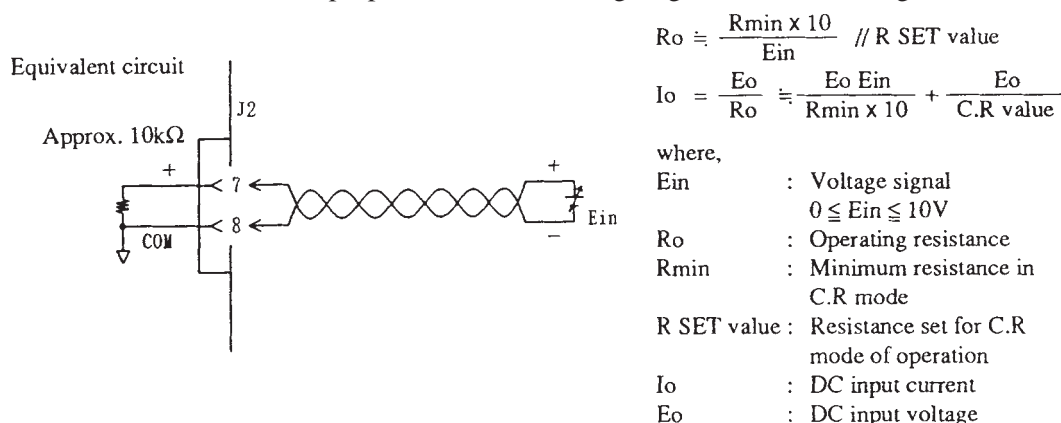

Figure 3.7-5

■ Setup procedure

- 1) Turn OFF the POWER switch on the front panel.
- 2) Connect the voltage signal to pins ⑦ and ⑧ of connector J2 on the rear panel.
- 3) Set SW2 on the rear panel to REM and SW3 to V.
- 4) Turn ON the POWER switch on the front panel.
- 5) Press the **【R SET】** key on the front panel to enable the C.R mode.
- 6) Set the voltage signal to 0 V and adjust the maximum resistance with the OFS potentiometer on the rear panel; set the voltage signal to 10 V and adjust the minimum resistance with the FS potentiometer on the rear panel.
- 7) Press the **【SHIFT】** + **【STOP】** (KEYLOCK) keys to lock the keys of the Electronic Load.

Caution

- The maximum voltage allowable between pins ⑦ and ⑧ of J2 is ± 11 V. If you apply a voltage higher than this, the Electronic Load may be damaged. If the voltage signal is lower than 0 V or higher than 10 V, the performance of the Electronic Load may not meet the accuracy it claims in its performance specifications.
- Pin ⑧ of J2 is internally connected to the "-" load terminal. Be careful not to bring pin ⑧ into contact with other pins.

NOTE

- When in this mode of remote control operation, the resistance exhibited by the Electronic Load is the sum of the remote-controlled resistance proportional to the voltage signal plus the local-controlled resistance (R SET value) set from the front panel. On the front panel display, the local-controlled resistance alone is displayed. Due to this, lest the R SET value should be disturbed, operate the Electronic Load in the keylock state.
- For connection of the remote control signal, use twisted pair wires or a shielded cable to prevent noise. For the external voltage signal, use a stable voltage source of less noise.
- The connector pins used here are the same with those used for remote control of the C.C mode with an external voltage signal. Be sure to select the correct mode.

[2] Current control with an external resistance

With an external resistor of 0 to approximately 10 kΩ, you can control the resistance the Electronic Load exhibits, as shown in Figure 3.7-6. The control setup is the simplest as compared with those required by other remote control methods.

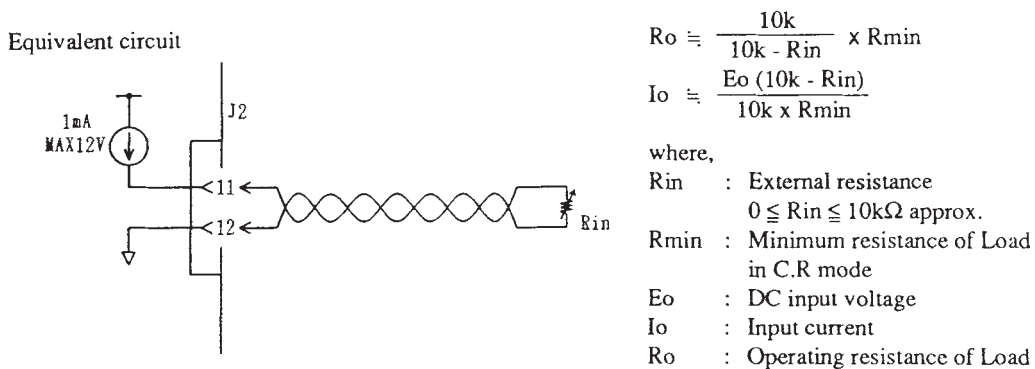

Figure 3.7-6

■ Setup procedure

- 1) Be certain that the Electronic Load is in the load-off state.
Locally from the front panel, set the R SET value at the minimum resistance.
- 2) Turn OFF the POWER switch on the front panel.
- 3) Connect the external resistor to pins ⑪ and ⑫ of connector J2 on the rear panel and set the resistance at the maximum.
- 4) Set SW2 on the rear panel to LOCAL and SW3 to R.
- 5) Turn ON the POWER switch on the front panel.
- 6) Press the **[R SET]** key on the front panel to enable the C.R mode.
- 7) Press the **[SHIFT] + [STOP]** (KEYLOCK) keys to lock the keys of the Electronic Load.

NOTE

- For resistor R_{in} , use a quality resistor of good stability against temperature change and aging. If you are using a potentiometer, use a one whose residual resistance is less than 300 ohms. The recommended types of resistors are as follows:
Wire wound resistors
Metallic film resistors
Vernier potentiometers
- For connection of the external resistor, use twisted pair wires or a shielded cable to prevent noise.
- If you set the R SET value at a value other than the minimum resistance locally from the front panel, the contrrollable resistance range of the Electronic Load may not cover the range claimed in the performance specification and the Electronic Load will exhibit the minimum resistance.
- The connector pins used here are the same with those used for remote control of the C.C mode with an external voltage signal. Be sure to select the correct mode.
- The control circuit of the Electronic Load is designed so that the current (I_o) becomes absolutely zero amperes when the external resistor (R_{in}) is $10k\ \Omega$ --this resistance with some tolerance as shown in Figure 3.7-7.

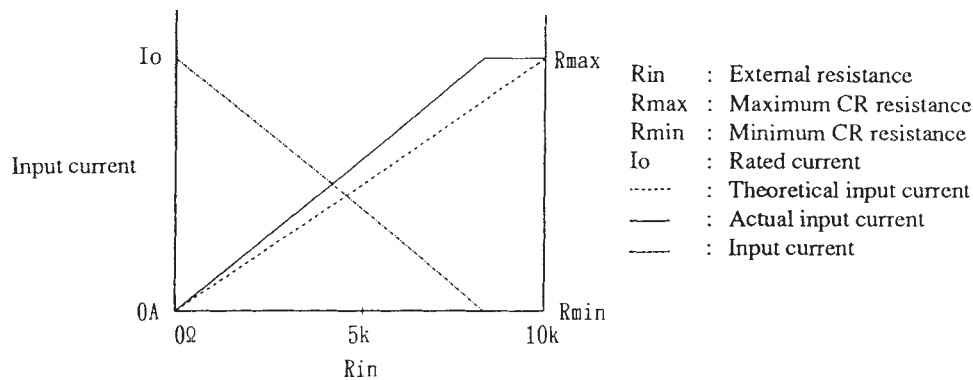

Figure 3.7-7

3.7.3 Analog Remote Control of C.P mode

With an external voltage signal of 0 to approximately 10 V, you can control the DC input power the Electronic Load consumes.

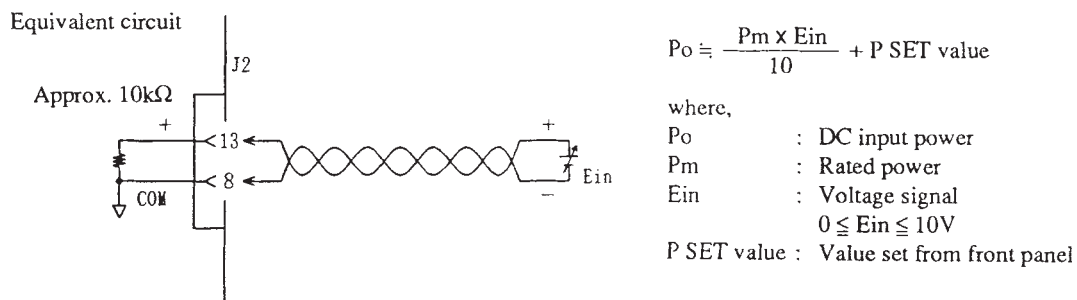

Figure 3.7-8

■ Setup procedure

- 1) Turn OFF the POWER switch on the front panel.
- 2) Connect the voltage signal to pins ⑬ and ⑧ of connector J2 on the rear panel.
- 3) Turn ON the POWER switch on the front panel.
- 4) Press the **[P SET]** key and enter a P SET value from the front panel.
- 5) Press the **[SHIFT]** + **[STOP]** (KEYLOCK) keys to lock the keys of the Electronic Load.

Caution

- The maximum voltage allowable between pins ⑬ and ⑧ of J2 is ± 11 V. If you apply a voltage higher than this, the Electronic Load may be damaged. If the voltage signal is lower than 0 V or higher than 10 V, the performance may not be within the guaranteed accuracy.
- Pin ⑧ of J2 is internally connected to the "-" load terminal. Be careful not to bring pin ⑧ into contact with other pins.

NOTE

- When in this mode of remote control operation, the DC power consumed by the Electronic Load is the sum of the remote-controlled power proportional to the voltage signal plus the local-controlled power (P SET value) set from the front panel. On the front panel display, the local-controlled power alone is displayed. Due to this, the P SET value should be disturbed, operate the Electronic Load in the keylock state.
- For connection of the remote control signal, use twisted pair wires or a shielded cable to prevent noise. For the external voltage signal, use a stable voltage source of less noise.

3.7.4 Remote Control of Load ON/OFF

You can remote-control the Electronic Load for load-on/off state by using an external contact signal. You can monitor remotely the load-on/off state by using the load on/off monitor output signal the Electronic Load delivers. You can also remote-control simultaneously two or more units of Electronic Loads connected in parallel, for load on/off.

[1] Load-on/off control with a contact signal (single unit)

You can remote-control the load-on/off state of a single unit of Electronic Load by applying an external contact signal to terminals ⑤ and ⑥ as shown in Figure 3.7.9. To turn Load-on/off with contact signal, turn the electronic load Load-off state with **[LOAD]** key on the front panel.

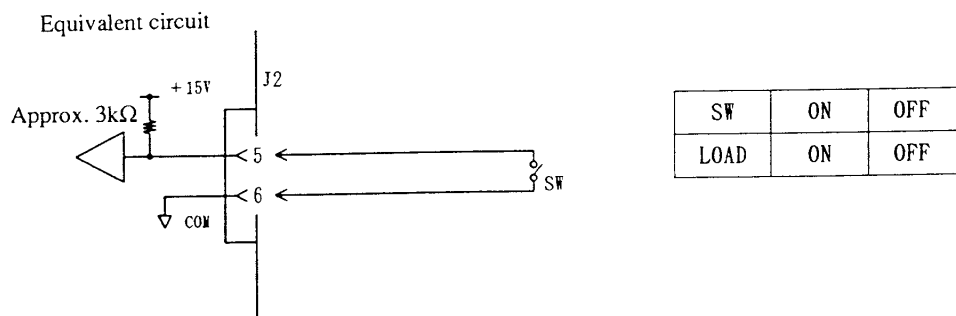

Figure 3.7-9

NOTE

- Load-on state by contact signal at operates, when Over-voltage, Overheat, Fuse blown out or Alarm detected, however, load-lamp does not tune off the light.
- A switching current of approximately 4.5 mA flow to the external contact (SW). The open voltage is approximately +1.5V.
- Be sure to return the switching current to pin ⑥ of J2.

[2] Load-on/off monitor output

The load-on/off monitor signal is delivered via pins ⑤ and ⑥ of J1 on the rear panel, allowing you to monitor remotely the load-on/off state of the Electronic Load.



Figure 3.7-10

NOTE

- Load-on state by contact signal at operates, when Over-voltage, Overheat, Fuse blown out or Alarm detected, however, Load-on/off monitor output keep on.
- The monitor signal circuit is isolated from other pins with a open-collector photocoupler.
- The ratings of the light-detecting section of the photocoupler are as follows:

V _{ceo}	: 30V
I _c	: 5mA
P _c	: 150mW

[3] Load-on/off control with a contact signal (multiple units)

You can remote-control the load-on/off state of a multiple units of Electronic Loads connected in parallel for master/slave operation, by applying an external contact signal to pins ⑤ and ⑥ of J1 of the master unit as shown in 3.7-11. Since pins ⑤ and ⑥ are isolated from the load terminals, this operation is applicable even when the load terminal voltages are not uniform.

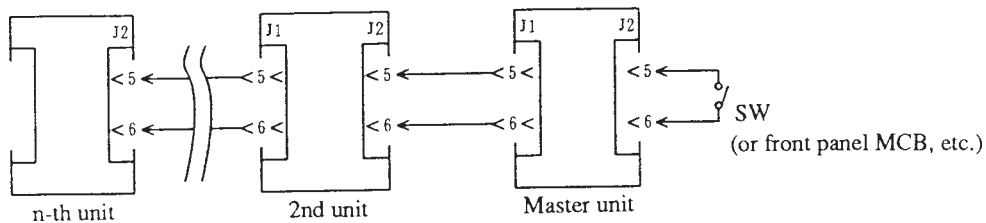

Figure 3.7-11

3.7.5 Remote Control of Range Select

You can remotely select the High or Low range for the C.C or C.R mode of operation by using an external contact signal as shown in Figure 3.7-12.

When selecting the range remotely, the local range setting from the front panel must be at the High range.

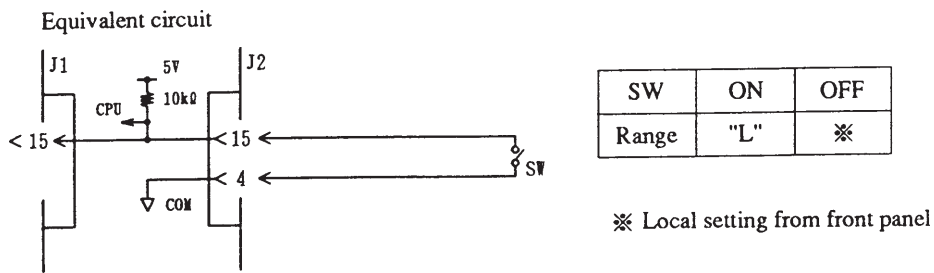

Figure 3.7-12

NOTE

- For range select operation, the remote select has a priority over the local select. That is, when the remote select is ON (for Low range), you cannot locally select the High range.
- A switching current of approximately 0.5 mA flow to the external contact (SW).
- Be sure to return the switching current to pin ④ of J2.

3.7.6 Trigger Signals

The Electronic Load delivers a trigger signal and accepts a trigger signal. You may use them for the following purposes:

- Trigger output signal: For synchronization to view on an oscilloscope the waveforms of switching actions.
- Trigger input signal: For remote control to release the Electronic load from the paused state (when in the sequence operation).

[1] Trigger output signal

The trigger output signal is delivered in parallel via both rear panel terminal (pins ③ and ④ of J1) and front output terminal (TRIG OUT terminal). The trigger signal can represent the following events:

- A trigger output is specified in sequence operation.
- A signal is applied to the trigger input terminal.
- A "GET" command is received through GPIB.
- A trigger output signal is enabled for switching action.

The trigger output signal circuitry is as shown in Figure 3.7-13.

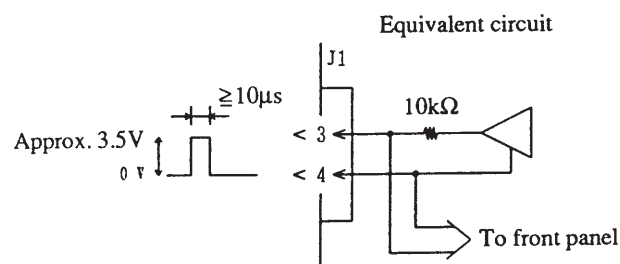

Figure 3.7-13

NOTE

- The voltage of the trigger output signal is approximately 3.5 V, pulse width is 10 μs or more, and the output impedance is approximately 10 kΩ.
- The trigger output signals of both terminals are isolated from the signals of other terminals.

[2] Trigger input signal

The Electronic Load accepts a trigger input signal via pins ③ and ④ of J2 on the rear panel as shown in Figure 3.7-14. The allowable maximum voltage of the trigger input signal is 6 V and the acceptable minimum pulse width is 20 μ s. You may use this function to drive the Electronic Load in synchronization with other Electronic Loads.

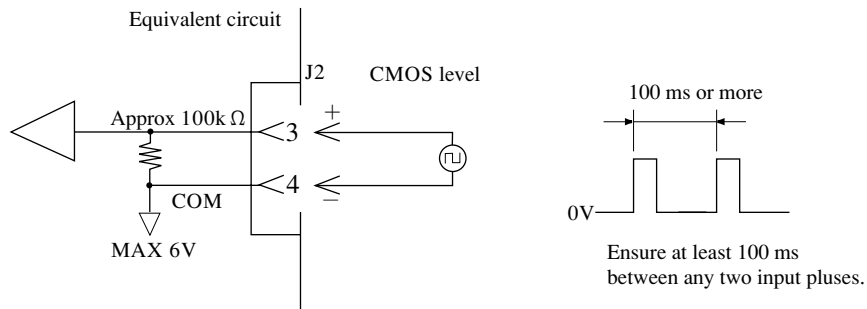

Figure 3.7-14

NOTE

- A trigger signal is generated at the rise-up edge of the pulse signal (the pulse width must be 20 μ s or greater).
- The input terminal is shunted with an internal resistor of approximately 100 k Ω . The maximum allowable input voltage is 6 V. The operating threshold level is TTL.

3.8 Master/Slave Parallel Operation

For a larger load current or power, you can operate a multiple number of Electronic Loads in parallel and control them in a master/slave mode as shown in Figure 3.8-1. The control lines of the units can be readily connected by using flat cables which have MIL-type connectors, providing a convenient means to increase the number of units.

NOTE • For parallel operation, be sure to use the input terminals on the rear panel.

Caution • The Electronic Loads must not be connected in series.

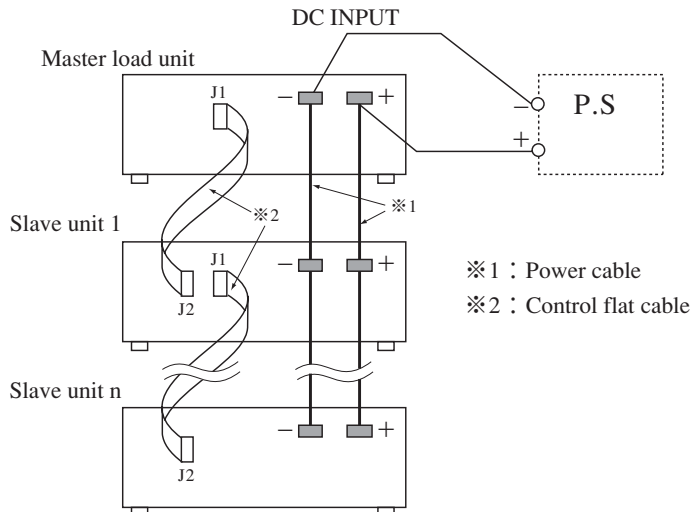

Figure 3.8-1

■ Setup procedure

- 1) Turn OFF the POWER switches of the Electronic Loads.
- 2) Connect the DC input terminals of the master unit and slave units in parallel as shown in Figure 3.8-1.
- 3) As shown in Figure 3.8-1, connect J1 of the master unit to that of slave unit 1 with a flat cable, connect J1 of slave unit 1 to that of slave unit 2, connect J1 of slave unit 2 to that of slave unit 3, and so forth.
- 4) Set the SW1-1 switch (DIP switch) to "ON" on the rear panel of each slave unit.
- 5) Press the **[SHIFT]** + **[R SET]** (CONFIG) keys of the master unit to invoke the configuration menu, select [14: Parallel Ope] from the menu, and specify the number of units to be operated in parallel.
- 6) Press the **[ESC]** key to return the display to its pre-setup status.

- Caution**
- Although the set ranges for the current, power, and resistance are all increased on the master unit, the pre-setup values still appear on the display. When you carry out parallel operation by a mode except CP mode, be sure to change PSET value of the master unit to the required power value.
 - Turn ON the POWER switches of all units simultaneously, or turn ON those of the slave units first and that of the master unit next. Message [*ALARM EXT] may appear.
 - If you make a wrong connection of J1 or J2, the Electronic Loads may be damaged. Be certain that the connections are correct.
 - Up to five Electronic Loads of the same units can be connected in parallel. If you want to connect more than five units in parallel, consult your Kikusui agent.
 - Make the cabling distances (of flat cables and load cables) as short as possible. For the load cables, use sufficiently heavy cables and strand them to prevent noise.

- *As you set the SW1-1 of the slave unit to ON, message [<SLAVE>] will appear on its display indicating that the Electronic Loads are in the master/slave mode. The mode displayed on a slave unit may differ from that on the master unit--this does not cause any trouble. The current value indicated on the display of a slave unit denotes the current being drawn by the slave unit itself--the values may differ among units slightly (several percent).*
- *As the number of units operated in parallel increases, the current, power and resistance ranges indicated on the master unit increase. The master unit indicates the sum of the currents (powers) of the units operated in parallel.*
- *If an alarm state (except the overcurrent alarm or reverse polarity alarm) is detected when in parallel operation, all units are driven into the load-off state and message [ALARM EXT] appears. To reset from the alarm state, reset at first the alarm state of the other unit connected to J1.*
- *Lay the DC power cable and control cable mutually apart. If you lay them closely, interference may result.*
- *When in the parallel operation, ripple of the DC input current is approximately equal to that of the single unit multiplied by the number of units operated in parallel.*
- *The ammeter reading of the master unit may differ by several percent from the sum of the ammeter readings of individual slave units. For ammeter calibration in this regard, refer to Item "Ammeter calibration for master/slave parallel operation" on the page after next.*

Flat cables for parallel operation

When laying flat cables, be sure to provide strain relief as shown in Figure 3.8-2 and make the pin layout as follows:

```

(P1)      (P2)
No. 1 ----- No. 1
No. 2 ----- No. 2
  •         •
  •         •
No. 16 ----- No. 16
    
```

Adjust the length (L) to suit the layout of units. The minimum length of L(when two units are stacked) is 20 cm.

A shielded type of flat cables are recommended. When using shielded cables, ground the shielding wires to the chassis.

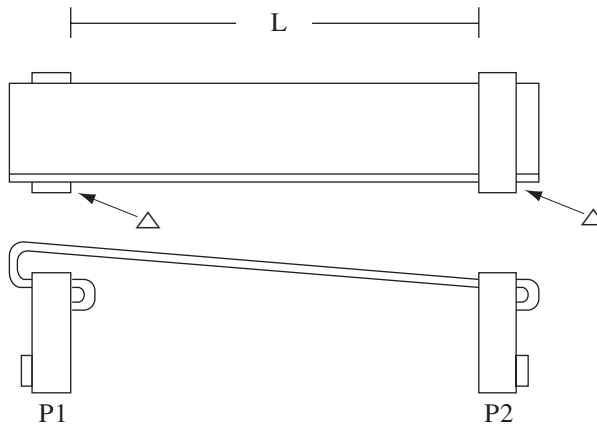

Figure 3.8-2

Connectors for flat cables

Manufacturer	Model
KEL	6200-016-601
OMRON	XG4M-1630 XG4T-1604

NOTE

- Direction of socket for mating -- When mating the flat cable connectors (with strain relief), in order to minimize interference, make the turned back portions of the cable as small as possible and direct the turned back portions in the same direction as shown in Figure 3.8-3.

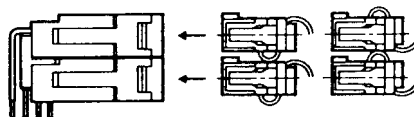

Figure 3.8-3

A P P E N D I X

■ Ammeter calibration for master/slave parallel operation

The Electronic Loads are shipped after calibrating their ammeters at vendor's factory. For parallel operation, however, they can be calibrated more accurately in the state that they are actually setup and connected for the parallel operation. This section introduces this calibration procedure.

1. Calibration Procedure

Connect the units referring to Section 3.8 "Master/Slave Parallel Operation" and then make calibration with the master unit. For the preparative procedure, measuring instruments required, connection method, and the procedure to enter the calibration mode, refer to Section 6.2 "Calibration."

After entering the calibration mode, proceed as follows:

- ① Select "offsIadSum" (ammeter offset calibration) with the **【◀】** and **【▶】** keys.

0. 0 0 A	5. 0 0 V	0. 0 W
C C	o f f s I a d S u m	3 5

- Press the **【LOAD】** key to drive the Electronic Load into the load-on state.
Apply a voltage to the load terminal so that V₁ becomes 5.00 V. Adjust the ammeter reading to 0.00 A with the JOG/SHUTTLE dial. (For V₁ and I₁, refer to Figure 6.2-1.)

- ② Select "gainIadSum" (ammeter full-scale calibration) with th **【◀】** and **【▶】** keys.

2 5. 2 0 A	5. 0 0 V	1 2 6. 0 W
C C	g a i n I a d S u m	2 2 5 3 9

- Press the **【LOAD】** key to drive the Electronic Load into the load-on state.
Apply a voltage to the load terminal so that V₁ becomes 5.00 V. Adjust the ammeter reading to the corresponding value shown in the below table with the JOG/SHUTTLE dial.

Caution

- *The offset calibration and full scale calibration may affect mutually. Repeat them alternately until both of them fall into allowable tolerances.*

- ③ Press the **【ESC】** key to exit from the calibration mode.

Model	No. of units operated in parallel			
	2 units	3 units	4 units	5 units
P L Z 1 5 3 W	1 2. 6 0 A	1 8. 9 0 A	2 5. 2 0 A	3 1. 5 0 A
P L Z 3 0 3 W	2 5. 2 0 A	3 7. 8 0 A	5 0. 4 0 A	6 3. 0 0 A
P L Z 6 0 3 W	5 0. 4 0 A	7 5. 6 0 A	1 0 0. 8 A	1 2 6. 0 A
P L Z 1 0 0 3 W	8 4. 0 0 A	1 2 6. 0 A	1 6 8. 0 A	2 1 0. 0 A

Ammeter reading when in "gainIADSum" calibration

Chapter 4

REMOTE

PROGRAMMING

This chapter describes the method to control the Electronic Load remotely from a controller via an interface board (optional).

Contents	Page
4.1 Initial Setting of Interface	4-4
4.1.1 GPIB Interface	4-4
4.1.2 RS-232C Interface	4-4
4.1.3 MCB Interface	4-5
4.2 Programming Format	4-6
4.2.1 Commands	4-6
4.2.2 Response Message	4-7
4.2.3 Acknowledge Message (RS-232C)	4-7
4.2.4 Flow Control (RS-232C)	4-8
4.3 Description of Commands	4-9
4.3.1 Terminology	4-9
4.3.2 Structures of Commands	4-10
4.4 Bit Assignment of Status Registers	4-28
4.5 SRQ, Status Bytes, and Registers	4-31
4.6 Table of Error Codes	4-32
4.7 Examples of Remote Programming	4-33
4.7.1 Initializing the Interface Board	4-33
4.7.2 Examples of Application Program	4-33
4.7.3 Table of Command Headers	4-38

You can remote-control the power supply from a personal computer or other controller via an optional interface board (refer to Section 7.4 "Options"). This chapter explains commands that you may use for this type of remote control.

NOTE

- *For the installation method of the interface board, refer to its operation manual*

■ Applicable Interface Boards

The remote-control commands introduced in this chapter are applicable to the following three types of interface boards:

- IB11 : GPIB Interface Board
- RS11 : RS-232C Interface Board
- MC11S: MCB (multichannel bus) Interface Board

For description of the commands in this chapter, special symbols are used as follows:

- : Characters of header, data and other items of a must
- [] : Data that you may omit
- [] : Data that is not required depending on mode
- <> : Pronominal argument characters
- () : Data that you may use instead

4.1 Initial Setting of Interface

4.1.1 GPIB Interface

[1] Setting the GPIB address

For the setting procedure of the GPIB address, refer to Section 3.5.9 "Configuration."

- NOTE** • *The factory-default for the GPIB address is "1".*

[2] Setting the response message terminator (delimiter)

For the response message terminator, select one of the following:

- C_RL_F+E_OI
- C_R+E_OI C_R : Carriage Return
- L_F+E_OI L_F : Line Feed
- E_OI E_OI : End of Identify

The response message terminator can be set by using the **TERM** command. For data transaction between the controller and the IB11, be sure to set the response message terminator beforehand. Unless the terminator has been correctly set, data transaction between them may be unsuccessful. For the **TERM** command, refer to [8] "System Commands" of Section 4.3.2.

- NOTE** • *The factory-defaults for the response message terminator is CrLf+EOI.*

[3] Setting the Power-on SRQ

For the setting method of the Power-on SRQ (service request), refer to Section 3.5.9 "Configuration."

- NOTE** • *The factory-default for the Power-on SRQ is "Disable."*

4.1.2 RS-232C Interface

[1] Setting the RS-232C protocols

When you have selected the RS-232C, be sure to set the items mentioned below. For setting of these items, refer to Section 3.5.9 "Configuration." The figures enclosed in the parentheses are factory-defaults.

- Transfer rate (9600 bps)
- Data bit size (8 bits)
- Stop bit size (2 bits)
- Parity bit (none)

[2] Setting the response message terminator (delimiter)

For the response message terminator (delimiter), select one of the following:

- C_RL_F
- C_R C_R : Carriage Return
- L_F L_F : Line Feed
- N o n e

The response message terminator can be set by using the **TERM** command. For data transaction between the controller and the RS11, be sure to set the response message terminator beforehand. Unless the terminator has been correctly set, data transaction between them may be unsuccessful. For the **TERM** command, refer to [8] "System Commands" of Section 4.3.2 "Structures of Commands."

- NOTE** • *The factory-defaults for the response message terminator is C_RL_F.*

4.1.3 MCB Interface**[1] Setting the MCB device address**

When you have selected the MCB, be sure to set the device address for it. For the setting procedure of the MC11S device address, refer to Section 3.5.9 "Configuration."

- NOTE**
- *Set the MCB device addresses as follows.*
Slaves: Any of 1 to 15
The address of the master unit is automatically fixed at 0 by the GPIB or RS-232C board.
 - *The factory default for the MCB device address is 15.*

4.2 Programming Format

This section describes the structures of general programming formats.

4.2.1 Commands

These are the commands that are fed to the GPIB controller or RS-232C terminal to the Electronic Load.

[1] Program message

This command is to operate the Electronic Load. It consists of a header and data, and is in a form of trains of ASCII code characters.

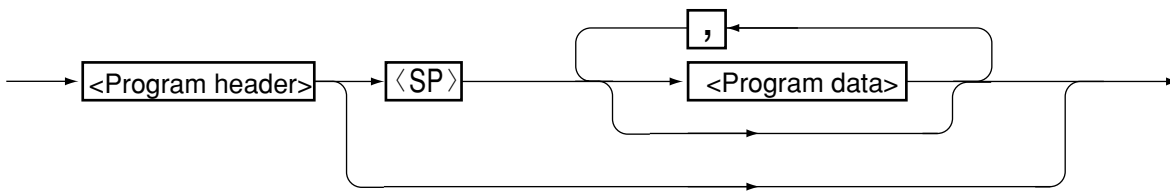

Figure 4.2-1

[2] Query message

This command is to obtain information from the Electronic Load. It consists of a header (with a "?") and data, and is in a form of trains of ASCII code characters.

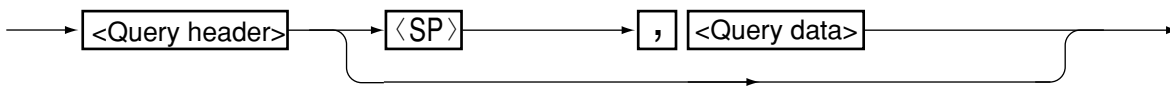

Figure 4.2-2

[3] Compound message

This message consists of two or more program messages and a query message.

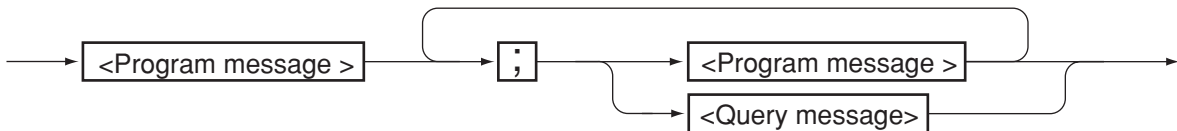

Figure 4.2-3

NOTE

- By adding an "@" at the end of a program message or a query message, GPIB can be held-off until execution of the message is complete. However, in the event of a program message terminator with only EOI, use "@@".
- The above hold-off function is peculiar to the GPIB interface board (IB11).

4.2.2 Response Message

The response message is a message returned by the Electronic Load to the GPIB controller or RS-232C terminal, in response to a query message. The response message consists of a header and data, and is in the form of trains of ASCII code characters. All response header and response data are returned with uppercase characters of ASCII codes.

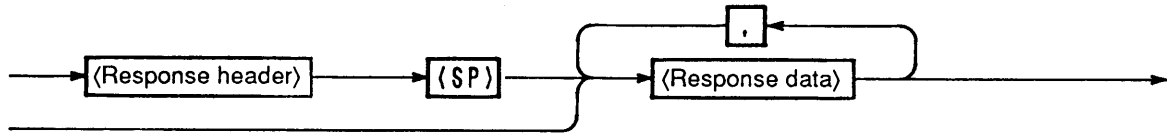

Figure 4.2-4

4.2.3 Acknowledge Message (RS-232C)

An acknowledge message corresponding to a program message is sent from the Electronic Load to the RS-232C terminal, notifying that the processing for the program message is complete. The acknowledge message consists only of a header, and is in a form of trains of ASCII code characters.

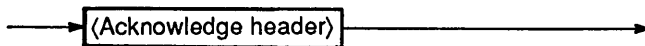

Figure 4.2-5

NOTE

- The acknowledge message is peculiar to the RS-232C interface board (RS11).
- There are three types of acknowledge headers as follows:

"OK" : Normally ended
 "ERROR" : Syntax error or other error occurred
 "TIMEOUT" : MCB address error.

- The acknowledge message can be turned ON/OFF with the **SILENT** command. For the **SILENT** command, refer to [9]"Commands and controls for RS-232C only" of Section 4.3.2 "Structures of Commands."
- The factory-default for the above is OFF.

4.2.4 Flow Control (RS-232C)

The transmit/receive operation of the RS11 can be controlled with XON/XOFF. These control codes are DC (device control) codes.

Table 4.2-1

	Action	ISO, EIA Codes
DC1	Request to send	11h
DC3	Request to stop sending	13h

[1] To control transmission from RS-232C terminal to RS11

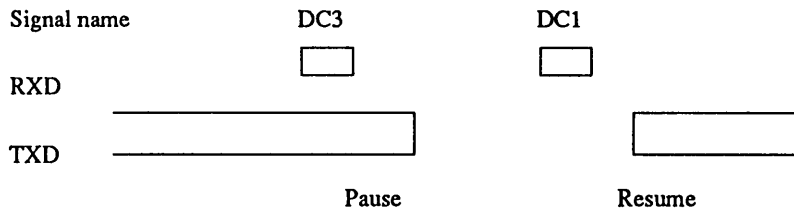

Transmission should be paused within 3 characters after receiving DC3.

[2] To control transmission from RS11 to RS-232C terminal

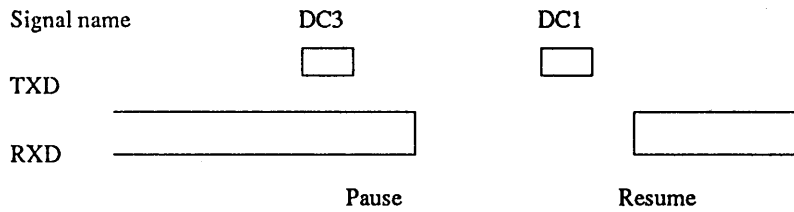

Transmission should be paused within 10 characters after receiving DC3.

NOTE

- *Transmission/receiving must be controlled by employing the functions of flow control or acknowledge messages. Communication may be unsuccessful with one-side dtransmission.*

4.3 Description of Commands

4.3.1 Terminology

This section explains the terms used in the commands.

[1] Header

The header is a keyword of a command and is composed of a train of ASCII code characters. You may use either uppercase or lowercase letters for headers, although uppercase letters are used throughout in this manual for better identification. You cannot put, however, a space character or the like within a header.

[2] Data

This item is an argument that immediately follows a header. The format of data differs depending on the type of header.

Table 4.3-1

Type of data

NR1	1 (ON)/0(OFF)
NR2	Decimal integer
NR3	Hexadecimal
NR4	Real number.(See the Note below.)
"string"	Alphanumeric character string (except control codes). Must be enclosed in double-quotes ("").
sp	Space code (20h)
?	Character "?" (3Fh)
,	Character "," (2Ch)

NOTE

- *Accepts integer, fraction, and exponent types of real number.*

Examples: 8, 1.25, 2.56E+1

- *The following units can be identified.*

Voltage: KV, V, MV ([V] for default)

Current: KA, A, MA ([A] for default)

Time: S, MS, US ([S] for default)

Resistance: K OHM, OHM, M OHM ([OHM] for default)

Power: KW, W, MW ([W] for default)

4.3.2 Structures of Commands

[1] Basic commands

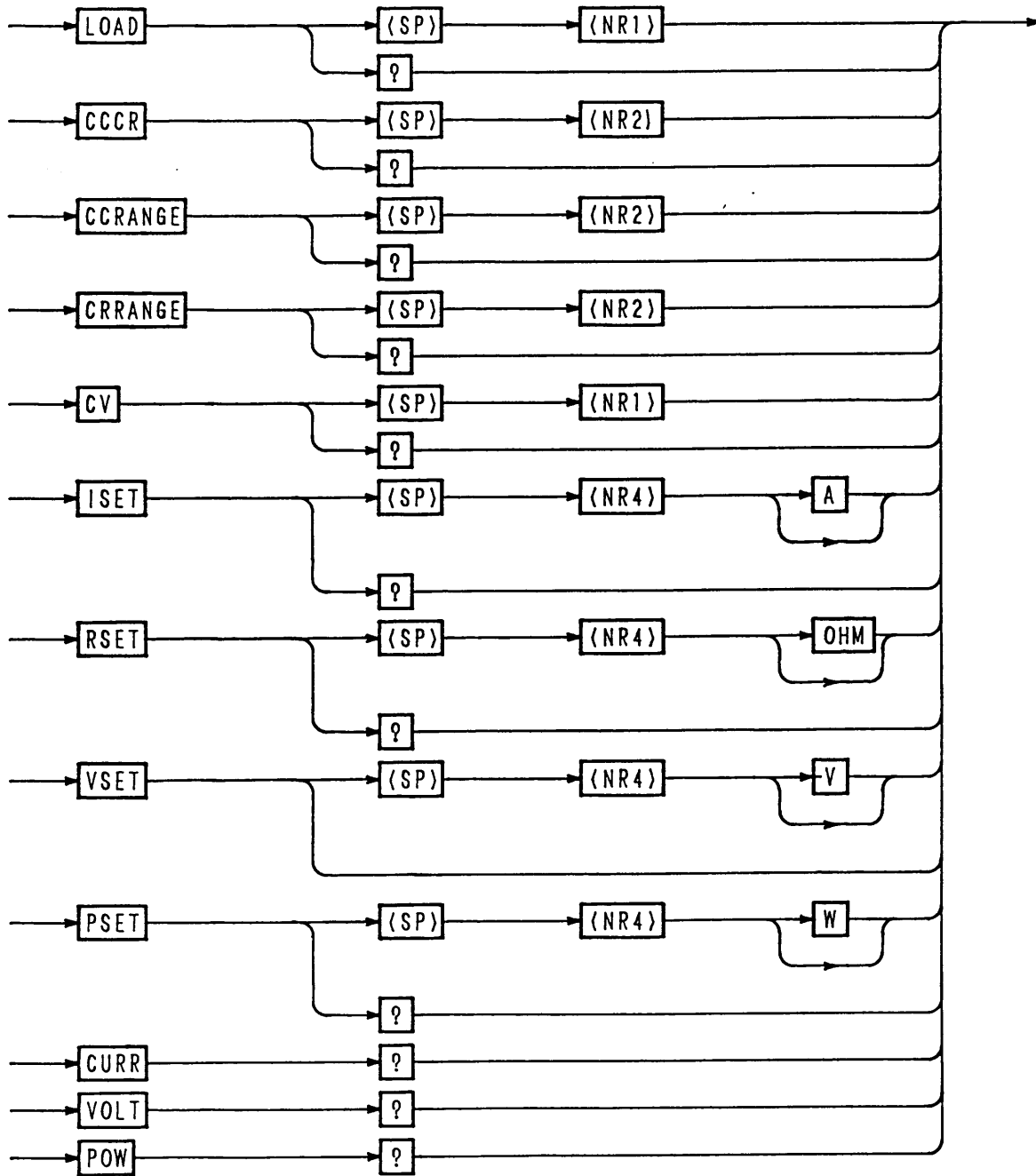

Figure 4.3-1

Table 4.3-2

Header	Data	Action	Backup
LOAD	0(OFF)	Set to load-off	No
	1(ON)	Set to load-on	
LOAD?		Return [0, 1]	
CCCR	1	Enable C.C mode	Yes
	2	Enable C.R mode	
CCCR?		Return [0, 1]	No
CCRANGE	0	Set to L range of C.C mode	Yes
	1	Set to H range of C.C mode	
CCRANGE?		Return [0, 1]	No
CRRANGE	0	Set to L range of C.R mode	Yes
	1	Set to H range of C.R mode	
CRRANGE?		Return [0, 1]	No
CV	0(OFF)	Disable C.V mode	Yes
	1(ON)	Enable C.V mode	
CV?		Return [0, 1]	No
ISSET	0 to max. [A]	Set I SET value	Yes
ISSET?		Return I SET value	No
RSET	Minimum resistance to 1000 [ohm]	Set R SET value	Yes
RSET?		Return R SET value	No
VSET	0 to max. [V]	Set V SET value	Yes
VSET?		Return V SET value	No
PSET	0 to max. [W]	Set P SET value	Yes
PSET?		Return P SET value	No
CURR?		Return DC input current	No
VOLT?		Return DC input voltage	No
POW?		Return DC input power	No

■ Programming example

```
'<< ISET , VSET , CURR? , VOLT? sample >>
  REM $INCLUDE: 'qbdecl.bas'
  devname$ = "DEV1"
  CALL ibfind(devname$, plz%)
  CALL ibclr(plz%)
  wrt$ = "TERM 3"
  CALL ibwrt(plz%, wrt$)
  wrt$ = "PSET 150;ISET 0"
  CALL ibwrt(plz%, wrt$)
  wrt$ = "CV ON;VSET 9"
  CALL ibwrt(plz%, wrt$)
  PRINT "Set the power supply to 10V , 10A."
  STOP
  wrt$ = "LOAD ON"
  CALL ibwrt(plz%, wrt$)
  FOR I = 0 TO 9      ' Power supply in CV mode; PLZ in CC mode
    wrt$ = "ISET " + STR$( I )
    CALL ibwrt(plz%, wrt$)
    wrt$ = "CURR?"
    CALL ibwrt(plz%, wrt$)
    rd$ = SPACE$(20)
    CALL ibrd(plz%, rd$)
    PRINT rd$
    wrt$ = "VOLT?"
    CALL ibwrt(plz%, wrt$)
    rd$ = SPACE$(20)
    CALL ibrd(plz%, rd$)
    PRINT rd$
  NEXT I
  wrt$ = "ISET 15"
  CALL ibwrt(plz%, wrt$)
  FOR V = 9 TO 0 STEP -1  ' Power supply in CC mode; PLZ in CV mode
    wrt$ = "VSET " + STR$( V )
    CALL ibwrt(plz%, wrt$)
    wrt$ = "CURR?"
    CALL ibwrt(plz%, wrt$)
    rd$ = SPACE$(20)
    CALL ibrd(plz%, rd$)
    PRINT rd$
    wrt$ = "VOLT?"
    CALL ibwrt(plz%, wrt$)
    rd$ = SPACE$(20)
    CALL ibrd(plz%, rd$)
    PRINT rd$
  NEXT V
  wrt$ = "LOAD OFF"
  CALL ibwrt(plz%, wrt$)
END
```

[2] Trigger setting command

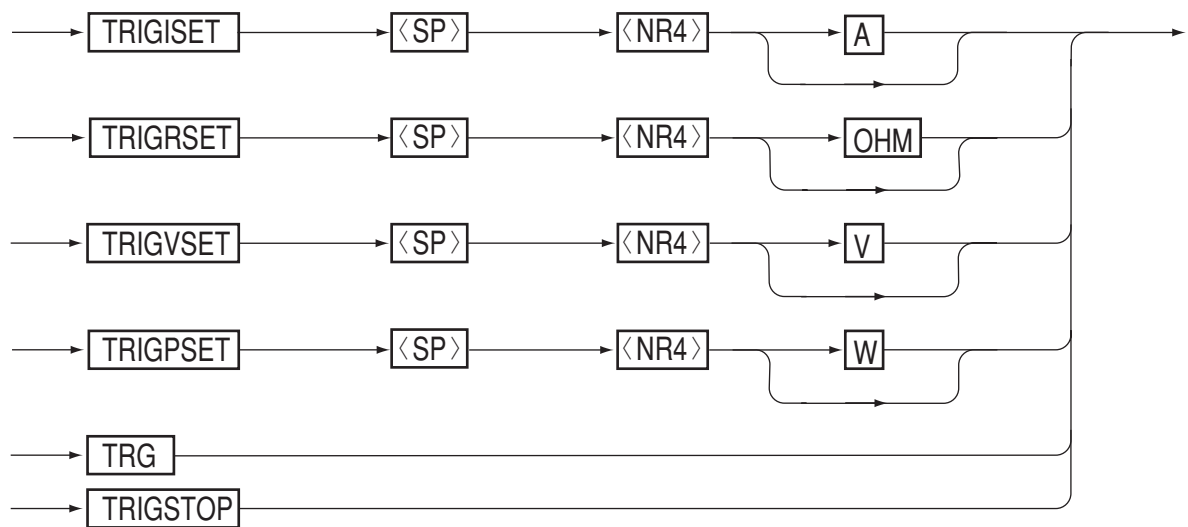

Figure 4.3-2

Table 4.3-3

Header	Data	Action	Backup
TRIGSET	0 to max. [A]	Set I SET value with immediately following <code>TRG</code> command	No
TRIGRSET	0 to 1000 [ohm]	Set R SET value with immediately following <code>TRG</code> command	No
TRIGVSET	0 to max. [V]	Set V SET value with immediately following <code>TRG</code> command	No
TRIGPSET	0 to max. [V]	Set P SET value with immediately following <code>TRG</code> command	No
TRIG		Execute contents of immediately preceding <code>TRIG:xxxx</code> command	No
TRIGSTOP		Clear TGR buffer	No

NOTE

- If other command is executed before `TRG` command after setting done for TRG buffer with the `TRIG:xxx` command, the TRG buffer becomes empty.
- If the TRG buffer is empty, no processing is done even when the `TRG` command is given.
- After executing the `TRG` command, the TRG buffer becomes empty.
- You may use the `GET` command instead of the `TRG` command for the same effect.

If the TRIGRSET command is executed in CC mode, an error will result. (Diff. Mode 15)

If the TRIGSET command is executed in CR mode, an error will result. (Diff. Mode 15)

[3] Memory commands

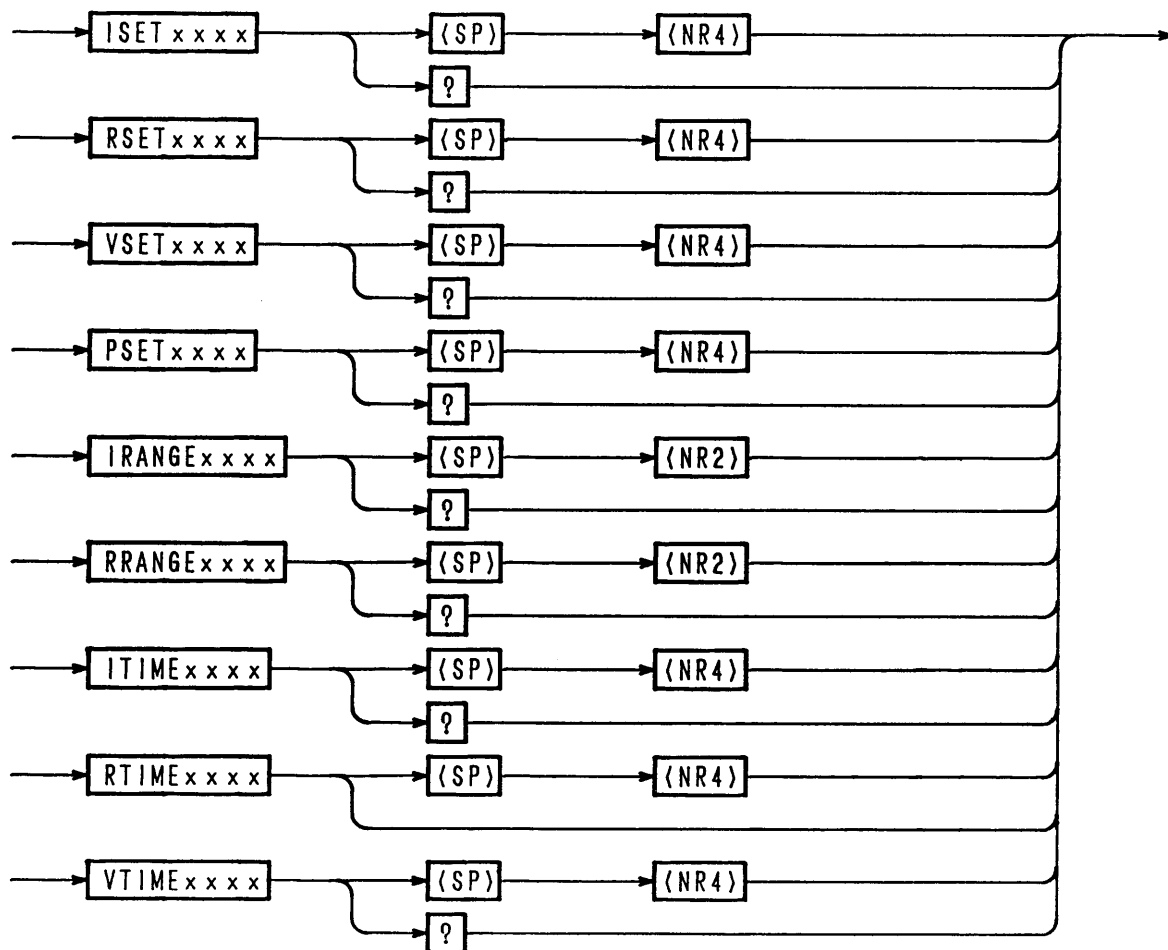

xxx AMEM for access to memory A
 xxx BMEM for access to memory B
 xxx CMEM for access to memory C

Figure 4.3-3

Table 4.3-4

Header	Data	Action	Backup
ISETxxxx	0 to max. [A]	Save I SET value to memory xxxx	Yes
ISETxxxx?		Return I SET value of memory xxxx	No
RSETxxxx	Min. resist to 1000 [OHM]	Save R SET value to memory xxxx	Yes
RSETxxxx?		Return R SET value of memory xxxx	No
VSETxxxx	0 to max. [V]	Save V SET value to memory xxxx	Yes
VSETxxxx?		Return V SET value of memory xxxx	No
PSETxxxx	0 to max. [W]	Save P SET value to memory xxxx	Yes
PSETxxxx?		Return P SET value of memory xxxx	No
IRANGExxxx	0	Save C.C range L to memory xxxx	Yes
	1	Save C.C range H to memory xxxx	
IRANGExxxx?		Return C.C range [0, 1] of memory xxxx	No
RRANGExxxx	0	Save C.R range L to memory xxxx	Yes
	1	Save C.R range H to memory xxxx	
RRANGExxxx?		Return C.R range [0, 1] of memory xxxx	No
ITIMExxxx	0 to 5 [s]	Save C.C execution time to memory xxxx	Yes
ITIMExxxx?		Return C.C execution time of memory xxxx	No
RTIMExxxx	0 to 5 [s]	Save C.R execution time to memory xxxx	Yes
RTIMExxxx?		Return C.R execution time of memory xxxx	No
VTIMExxxx	0 to 5 [s]	Save C.V execution time to memory xxxx	Yes
VTIMExxxx?		Return C.V execution time of memory xxxx	No

[4] Special Function Command

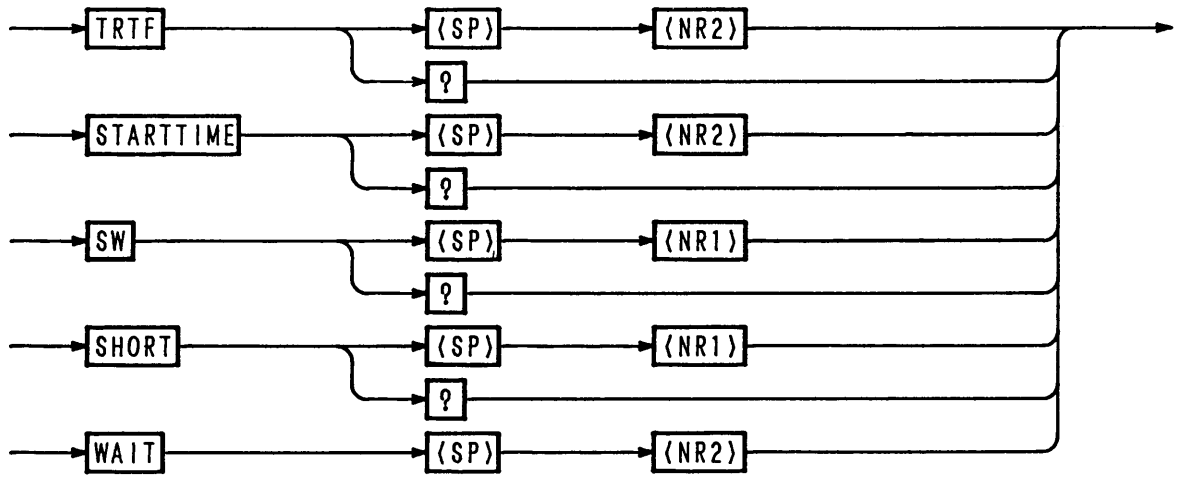

Figure 4.3-4

Table 4.3-5

Header	Data	Action	Backup
TRTF	0	Set Tr Tf at 50 μ s	Yes
	1	Set Tr Tf at 100 μ s	
	2	Set Tr Tf at 200 μ s	
	3	Set Tr Tf at 500 μ s	
	4	Set Tr Tf at 1 ms	
	5	Set Tr Tf at 2 ms	
	6	Set Tr Tf at 5 ms	
	7	Set Tr Tf at 10 ms	
TRTF?		Return Tr Tf	No
STARTTIME	0	Set soft start time at 0 ms	Yes
	1	Set soft start time at 1 ms	
	2	Set soft start time at 2 ms	
	3	Set soft start time at 5 ms	
	4	Set soft start time at 10 ms	
	5	Set soft start time at 20 ms	
	6	Set soft start time at 50 ms	
	7	Set soft start time at 100 ms	
STARTTIME?		Return soft start time	No
SW	0(OFF)	End switching action	No
	1(ON)	Start switching action (Operable mode must have been selected beforehand with CC or CR command.)	
SW?		Return [0, 1]	No
SHORT	0(OFF)	End Short action	No
	1(ON)	Start Short action	
SHORT?		Return [0, 1]	
WAIT	0 to 5 [s]	Execute processing for doning for period <NR2> seconds.	No

MEMO

[5] Setup commands

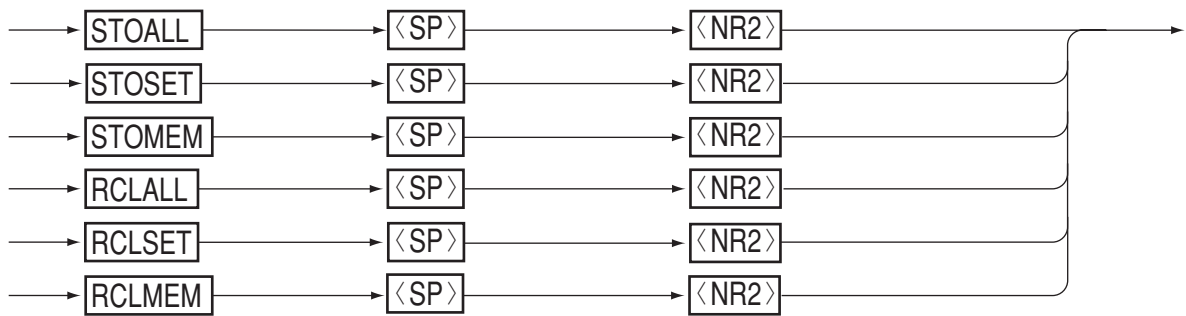

Figure 4.3-5

Table 4.3-6

Header	Data	Action	Backup
STOALL	1 to 4	Save settings of ALL section onto specified setup memory	No
STOSET	1 to 4	Save settings of SET section onto specified setup memory	No
STOMEM	1 to 4	Save settings of MEM section onto specified setup memory	No
RCLALL	0 to 4	Recall settings of ALL section from specified setup memory (0: Recall defaults of ALL section)	No
RCLSET	0 to 4	Recall settings of SET section from specified setup memory (0: Recall defaults of SET section)	No
RCLMEM	0 to 4	Recall settings of MEM section from specified setup memory (0: Recall defaults of MEM section)	No

[6] Sequence commands (1/2)

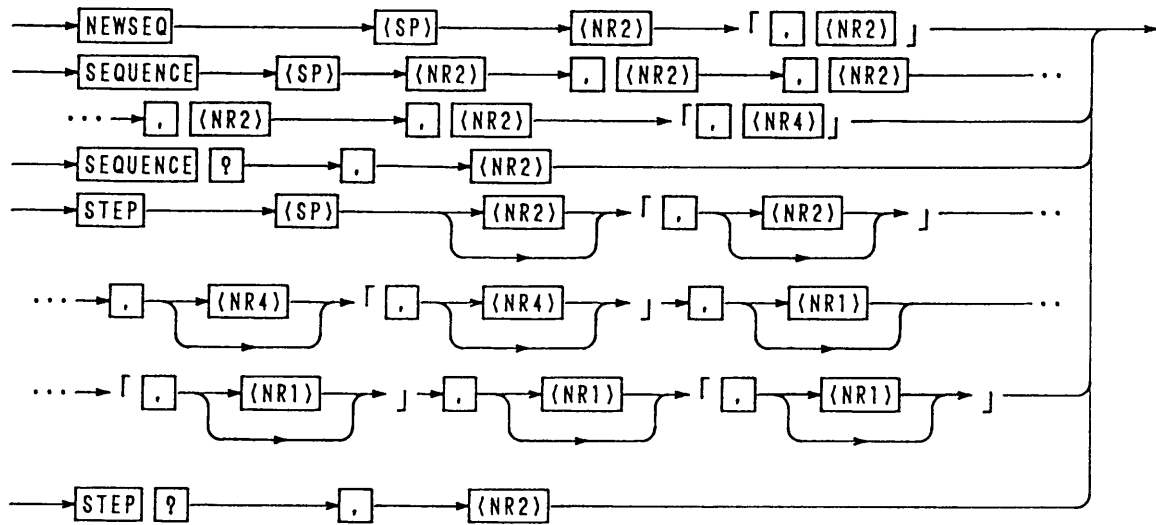

Figure 4.3-6

Figure 4.3-7

Header	No.	Data	Action	Backup		
NEWSEQ	①	1	Set to NV mode (Argument ② present)	No		
		2	Set to NI mode (Argument ② present)			
		4	Set to NR mode (Argument ② present)			
		5	Set to NP mode (Argument ② present)			
		11	Set to FI mode			
		12	Set to FR mode			
	②	1	Set to msec range			
		2	Set to sec range			
		3	Set to minute range			
		4	Set to hour range			
	SEQUENCE	①	1 - 8		Specify the sequence number	Yes
		②	1 - 16		Specify the start program	
③		1 - 9999	Specify the number of loops (9999 for infinitive repetitions)			
④		0,1 - 8	Specify the sequence number for chain destination (0 for no chain)			
⑤		0,1 - 16	Specify the end program number (0 for no end designation)			
⑥		0.0001-0.1	Execution time in FI/FR mode (effective when in FI/FR mode) (unit: sec)			
SEQUENCE?		1 - 8	Return the parameter of specified sequence number	No		
STEP	①	1 -	Specify the step number	Yes		
	*②	0	Specify a stepwise transition			
		1	Specify a rampwise transition			
	③	Value	Specify a value for the mode			
	*④	(Time)	Specify a period (unit in s)			
	⑤	0(OFF)	Set trigger output to OFF			
		1(ON)	Set trigger output to ON			
	*⑥	0(OFF)	Set to load-off			
		1(ON)	Set to load-on			
	*⑦	0(OFF)	Release Short function			
		1(ON)	Execute Short function			
	*⑧	0(OFF)	Set Pause to OFF			
		1(ON)	Set Pause to ON			
	STEP?		1 -		Return the parameter of specified step number	No

The items marked with * are not needed when in FI or FR mode.

[7] Sequence Commands (2/2)

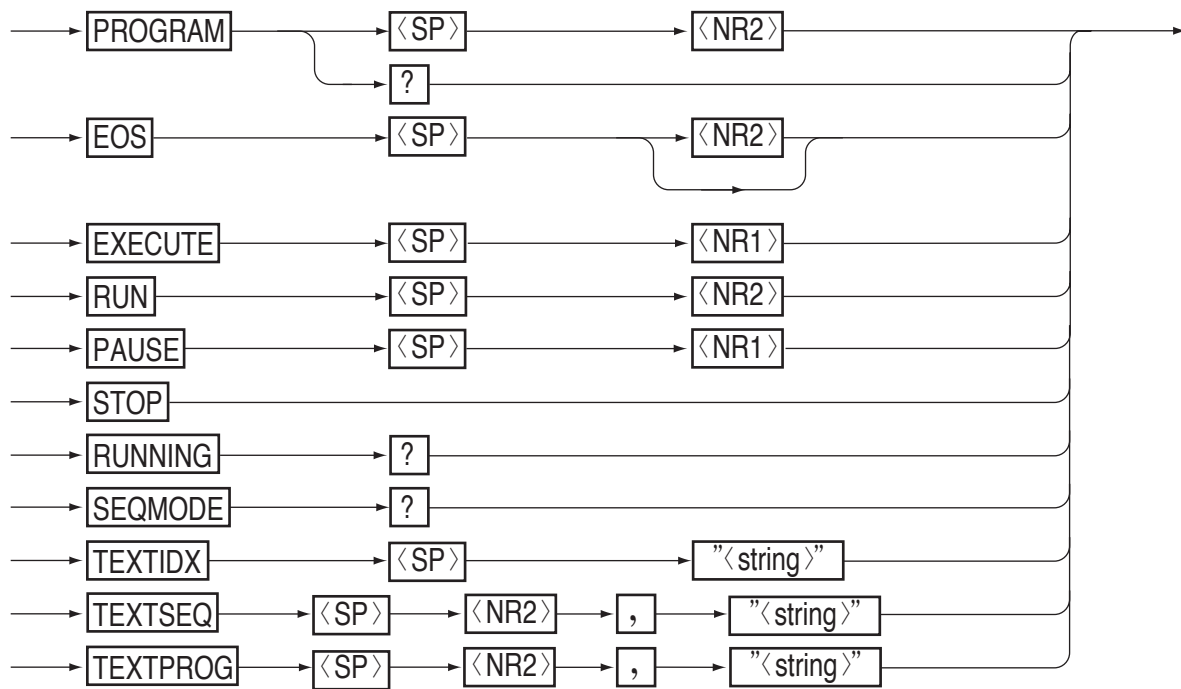

Table 4.3-7

Table 4.3-8

Header	Data	Action	Backup
PROGRAM	1 - 16	Specify the program number (Hereafter, effective for STEP and EOS commands)	No
PROGRAM?		Return the specified program number	No
EOS	1 - 1024	Set the final step number of the specified program	No
EXECUTE	1(ON)	Set to the execute mode (RUN, STOP, PAUSE enabled)	No
	0(OFF)	Release from the execute mode	
RUN	1 - 8	Run the specified sequence number	No
PAUSE	1(ON)	Pause the sequence	No
	0(OFF)	Release from pause	
STOP		Stop the sequence unconditionally	No
RUNNING?		Return the sequence run status data (<1-3>, <SEQ.NO>, <PROG.NO>, <STEP.NO>, <LOOP>) 1 STOP 2 RUN 3 PAUSE	No
SEQMOD?		Return the sequence mode data 1 NV mode 2 NI mode 4 NR mode 5 NP mode 11 ... FI mode 12 ... FR mode	No
TEXTIDX	Train of characters	Provide an index with a train of up to six characters, for execution sequence memory	Yes
TEXTSEQ	① 1 - 8	Specify a sequence number	Yes
	② Train of chara.	Write a comment with a train of up to six characters, for the specified sequence number	
TEXTPROG	① 1 - 16	Specify a program number	Yes
	② Train of chara.	Write a comment with a train of up to six characters, for the specified program number	

[8] System commands

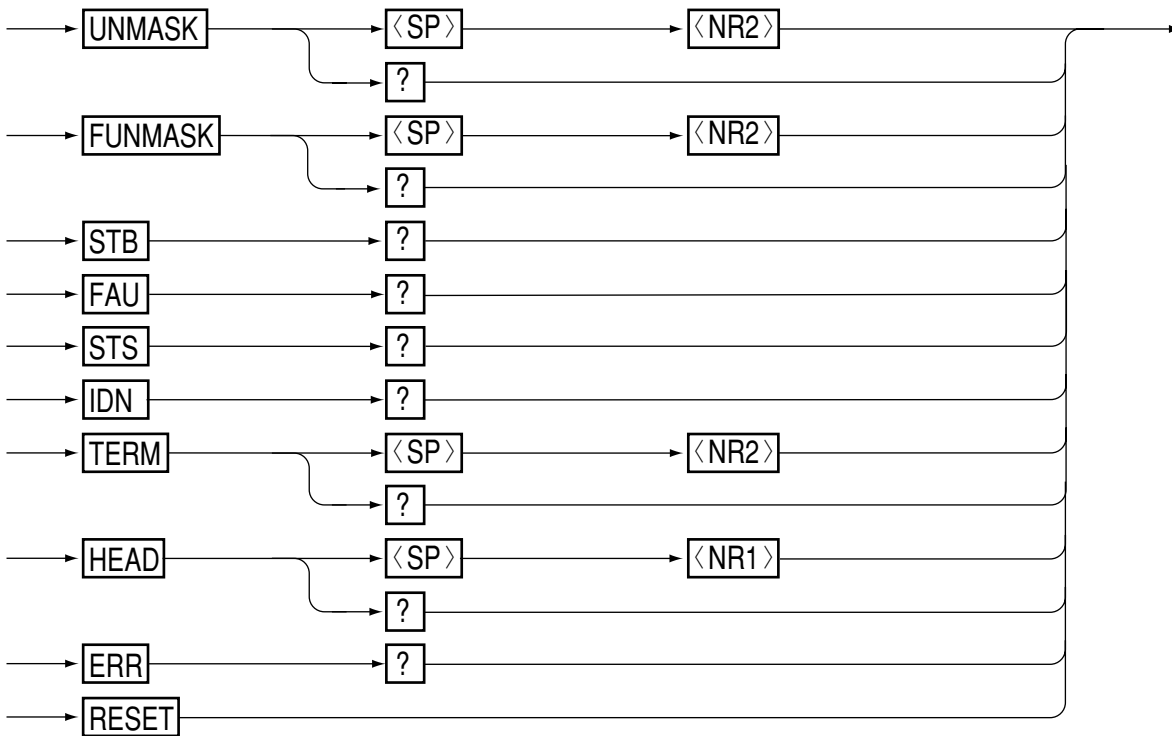

Figure 4.3-8

Table 4.3-9

Header	Data	Action	Backup
UNMASK	0 - 255	Set the unmask register	No
UNMASK?		Return the UNMASK value in decimal	
FUNMASK	0 - 255	Set the fault unmask register	No
FUNMASK?		Return the FUNMASK value in decimal	
STB?		Return the status byte register value in decimal	No
FAU?		Return the fault register value in decimal	No
STS?		Return the status register value in decimal	No
IDN?		Return the model and ROM version number	No
TERM	0	Set the response terminator to "C _R L _F "	No
	1	Set the response terminator to "C _R "	
	2	Set the response terminator to "L _F "	
	3	Set the response terminator to "EOI" only	
TERM?		Return [0, 1, 2, 3]	
HEAD	1	Add a query header to the query message	No
	0(OFF)	Add no query header to the query message	
HEAD?		Return [0, 1]	
ERR?		Return error code (Refer to 4.6 "Table of Error Codes.")	No
RESET	None	Reset from alarm status	No

[9] Commands for MCB only

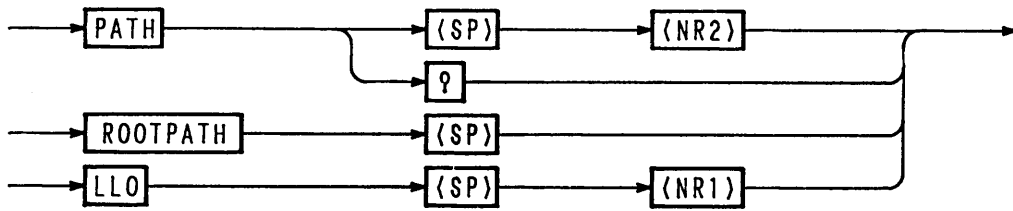

Figure 4.3-9

Table 4.3-10

Header	Data	Action	Backup
PATH	Address (0 - 15, 16)	Set the MCB bus address (bus address 16: for all addresses)	No
PATH?		Return the MCB bus address	
ROOTPATH		Set the bus address to 0	No
LLO	1(ON)	Set to local lockout	No
	0(OFF)	Release from local lockout	

NOTE

- For the MCB bus address, specify an address which actually exists. When you have specified an address which does not actually exist, send <DCL> to GPIB. The bus address will be set to 0 (master).
- For answer to the query message on bus address 16, bus address 0 (master) will be returned.

[10] Commands and control codes for RS-232C only

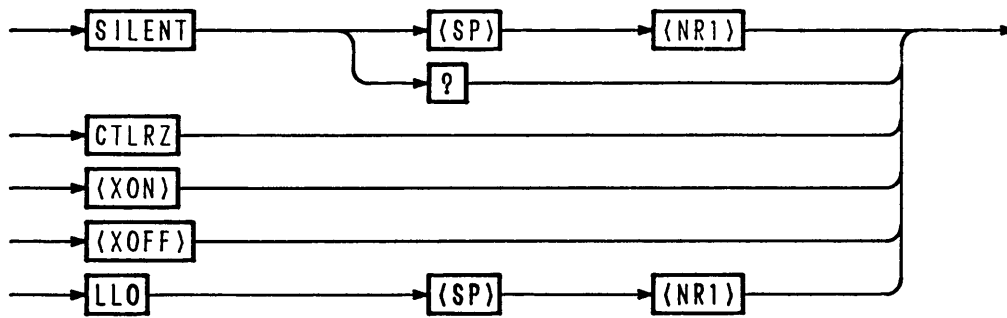

Figure 4.3-10

Table 4.3-11

Header	Data	Action	Remarks
SILENT	1(ON)	Do not return the acknowledge message	No
	0(OFF)	Return the acknowledge message	
SILENT?		Return [1, 0]	
CTRLZ		Return the control Z code (1Ah)	No
<XON> (11h)		Resume transmission from RS-11 (Refer to Section 4.2.4 "Flow Control.")	No
<XOFF> (13h)		Stop transmission from RS-11 (Refer to Section 4.2.4 "Flow Control.")	
LLO	1(ON)	Set to local lockout	No
	0(OFF)	Release from local lockout	

[11] Commands and special codes for GPIB only

- <DCL> : To set the MCB bus address to 0. To clear the error message
 <SDC> : The same as above
 <GET> : The same as the **TRG** command
 "@" : The "@" code (40h) suffixed to a program command is for hold off until execution of the message ends.
 However, in the event of a program message terminator with only EOI, use "@@".

Examples:

```
wrt$="ISET 5.0A"
CALL ibwrt(plz%, wrt$)      ' Get message into the input buffer and then proceed to the next
wrt$="ISET 5.0A@"
CALL ibwrt+(plz%, wrt$)    ' Execute <ISET 5.0A> and then proceed to the next
```

4.4 Bit Assignment of Status Registers

NOTE • Of all bits, "1" denotes "true."

[1] Status byte register

7	6	5	4	3	2	1	0
X	R Q S	X	M C B	E R R	S E	P O N	F A U

- Bit 0 [FAU] : Means that one of the fault register bits is "true."
 *Bit 1 [PON] : Denotes the power-on status.
 *Bit 2 [SE] : Means that the sequence is over.
 *Bit 3 [ERR] : Means that a syntax error or other error has occurred.
 Bit 4 [MCB] : Means that an SRQ is received from MCB.
 Bit 5 [X] : Undefined
 Bit 6 [RQS] : Means that an SRQ is originated.
 Bit 7 [X] : Undefined

NOTE

- Bit 1 [PON] and bit 6 [RQS] are effective for the IB11 interface board only.
- Bit 3 [ERR] can be reset with the ERR? query.
- Bit 6 [RQS] can be reset by serial polling of GPIB.
- Bit 1 [PON] and bit 2 [SE] are undefined for the STB? query.

[2] Unmask register

7	6	5	4	3	2	1	0
			M C B	E R R	S E		F A U

- Bit 0 [FAU] : To originate an SRQ when one of the register bits is "true."
 Bit 1 [] : Not used
 *Bit 2 [SE] : To originate an SRQ when the sequence is over.
 *Bit 3 [ERR] : To originate an SRQ when a syntax error or other error has occurred.
 Bit 4 [MCB] : To originate an SRQ as requested via MCB.
 Bit 5 [] : Not used
 Bit 6 [] : Not used
 Bit 7 [] : Not used

NOTE • For the bits which are not used, set "0".

[3] Fault register

7	6	5	4	3	2	1	0
C P	C V	EXTALM	F B	R E V	O H P	O C P	O V

- Bit 0 [OV] : Overvoltage detection
- Bit 1 [OCP] : OCP action
- Bit 2 [OHP] : OHP action
- Bit 3 [REV] : Reverse voltage polarity detection
- Bit 4 [FB] : Fuse blown-out detection
- Bit 5 [EXTALM] : External alarm detection
- Bit 6 [CV] : C.V mode
- Bit 7 [CP] : C.P mode

NOTE

- Each bit of the fault register has a latch function. It holds its set state until it is read by a `FAU?` query.

[4] Fault unmask register

7	6	5	4	3	2	1	0
C P	C V	EXTALM	F B	R E V	O H P	O C P	O V

- Bit 0 [OV] : Enables the OV bit of fault register.
- Bit 1 [OCP] : Enables the OCP bit of fault register.
- Bit 2 [OHP] : Enables the OHP bit of fault register.
- Bit 3 [REV] : Enables the REV bit of fault register.
- Bit 4 [FB] : Enables the FB bit of fault register.
- Bit 5 [EXTALM] : Enables the EXTALM bit of fault register.
- Bit 6 [CV] : Enables the CV bit of fault register.
- Bit 7 [CP] : Enables the CP bit of fault register.

NOTE

- For the bits which are not used, set "0".

[5] Status register

7	6	5	4	3	2	1	0
CP	CV	EXTALM	FB	REV	OHP	OCP	OV

- Bit 0 [OV] : Overvoltage detection
- Bit 1 [OCP] : OCP action
- Bit 2 [OHP] : OHP action
- Bit 3 [REV] : Reverse voltage polarity detection
- Bit 4 [FB] : Blow out fuse detection
- Bit 5 [EXTALM] : External alarm detection
- Bit 6 [CV] : C.V mode
- Bit 7 [CP] : C.P mode

4.5 SRQ, Status Bytes, and Registers

The Electronic Load has registers which are used to notify to the controller the events occurred in the Electronic Load. This section explains the relationships among SRQ, status bytes, and registers.

Relationships among SRQ, status bytes, and registers

NOTE • The SRQ function is available for GPIB only.

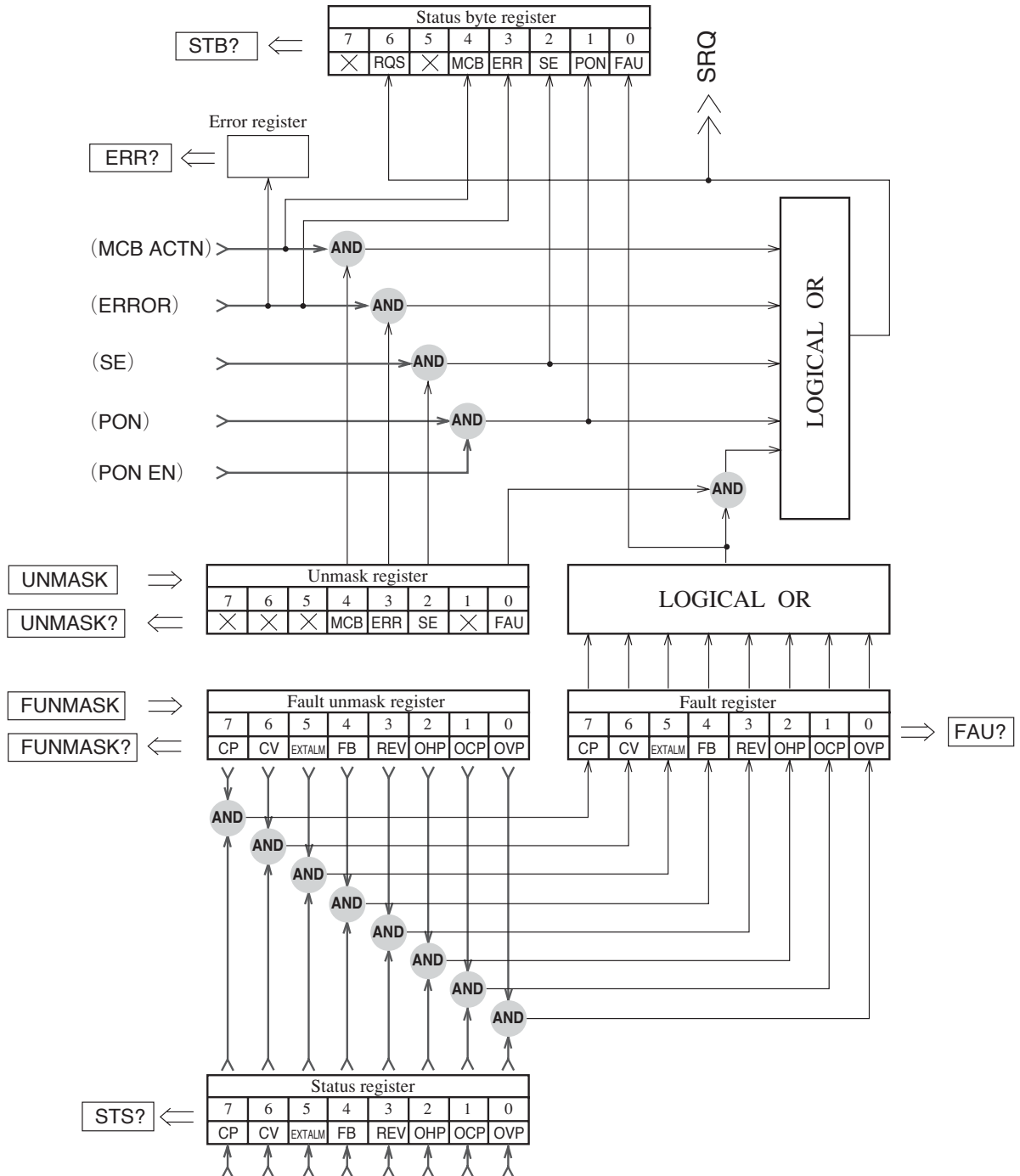

Figure 4.5-1

4.6 Table of Error Codes

Table 4.6-1

Error message	Error code	Meaning
Syntax Error	1	There is a syntax error in command.
Argument Error	2	There is an error in argument on command line.
Memory Full	14	Memory is full (no space available to write sequence program steps).
Diff. Mode	15	Basic operation mode settings do not comply with command received.
Warning Data	16	A value exceeding the rated value is specified for a sequence setting value.
SW State	21	An unacceptable command is given when in the switching operation.
SEQ State	22	An unacceptable command is given when in the sequence operation (in RUN or PAUSE)
SHORT State	23	An unacceptable command is given when in the Short action.
Alarm State	24	An alarm is given when in an alarm state.
SLAVE State	25	An unacceptable command is given when in the SLAVE mode.
CV OFF	26	The VSET command is given when in the "C.V mode OFF" state.
EXECUTE0	27	When the sequence does not run, execute the EXECUTE1 command and then run the sequence.
Invalidity	28	An invalid command is given.

NOTE

- Each time an error occurs, it is written onto the error register. Thus, the error code returned in response to the [ERR?] query is of the error which occurred latest. The error register is cleared when the [ERR?] query, [CLR] command, <DCL>, or <SDC> is given.

4.7 Examples of Remote Programming

4.7.1 Initializing the Interface Board

First of all, set the parameters of the interface board. The items to be set are as shown below. For the setting procedure, refer to Section 3.5.9 "Configuration".

GPIB interface board (IB11)

- GPIB device address
- Power-on service request

RS-232C interface board (RS11)

- Data transmission rate (BPS)
- Data bit length
- Stop bit length
- Parity bit (Even/Odd/None)

MCB slave interface board (MC11S)

- MCB device address

4.7.2 Examples of Application Program

This section introduces typical examples of program for remote programming, assuming that the controller is an IBM personal computer PS2 with MC-GPIB(NI-488.2), the software is the QuickBASIC, and the controlled device is a PLZ153W. The address and response terminator(delimiters) are assumed to be as shown in the bellow table.

	Address	Response terminator
IBM PS2	0	CRLF
PLZ153W	1	CRLF

NOTE

- Unless specified otherwise, the programming examples assume GPIB for interface. PS2 is trademark of IBM Corporation. NI-488.2 is trademark of National Instruments Corporation. QuickBASIC is trademark of Microsoft Corporation.

(1) Example of program for Current setting and monitor readback

```
'<< CCRANGE sample >>
REM $INCLUDE: 'qbdecl.bas'
devname$ = "DEV1"
CALL ibfind(devname$, plz%)
CALL ibclr(plz%)
wrt$ = "LOAD ON"
CALL ibwrt(plz%, wrt$)
wrt$ = "CCRANGE 0"           ' L range
CALL ibwrt(plz%, wrt$)
wrt$ = "ISET 5.999"         ' Down to three places of decimal
CALL ibwrt(plz%, wrt$)
wrt$ = "ISET?"
CALL ibwrt(plz%, wrt$)
rd$ = SPACE$(20)
CALL ibrd(plz%, rd$)
PRINT rd$
wrt$ = "CCRANGE 1"         ' L range
CALL ibwrt(plz%, wrt$)
```

```

wrt$ = "ISET 59.99"           ' Down to two places of decimal
CALL ibwrt(plz%, wrt$)
wrt$ = "ISET?"
CALL ibwrt(plz%, wrt$)
rd$ = SPACE$(20)
CALL ibrd(plz%, rd$)
PRINT rd$
wrt$ = "LOAD OFF"
CALL ibwrt(plz%, wrt$)
END

```

(2) Example of program for Memory setting and Switching action

```

'<< MEMOTY , SWITCHING MODE sample >>
REM $INCLUDE: 'qbdecl.bas'
devname$ = "DEV1"
CALL ibfind(devname$, plz%)
CALL ibclr(plz%)
wrt$ = "ISETAMEM 10"         ' Set current vale on memory A
CALL ibwrt(plz%, wrt$)
wrt$ = "ISETBMEM 20"       ' Set current vale on memory B
CALL ibwrt(plz%, wrt$)
wrt$ = "ISETCMEM 30"       ' Set current vale on memory C
CALL ibwrt(plz%, wrt$)
wrt$ = "ITIMEAMEM 100MS"   ' Set time on memory A
CALL ibwrt(plz%, wrt$)
wrt$ = "ITIMEBMEM 100MS"  ' Set time on memory B
CALL ibwrt(plz%, wrt$)
wrt$ = "ITIMECMEM 100MS"  ' Set time on memory C
CALL ibwrt(plz%, wrt$)
wrt$ = "LOAD ON"
CALL ibwrt(plz%, wrt$)
wrt$ = "SW 1"              ' Set switching mode to ON
CALL ibwrt(plz%, wrt$)
STOP
wrt$ = "SW 0"
CALL ibwrt(plz%, wrt$)
wrt$ = "LOAD OFF"
CALL ibwrt(plz%, wrt$)
END

```

(3) Example of program for Sequence operation

```

'<< SEQUENCE sample >>
  REM $INCLUDE: 'qbdecl.bas'
  devname$ = "DEV1"
  CALL ibfind(devname$, plz%)
  CALL ibclr(plz%)
  wrt$ = "EXECUTE 0"
  CALL ibwrt(plz%, wrt$)
  wrt$ = "NEWSEQ 2,1"
  CALL ibwrt(plz%, wrt$)
'-- Sequence --
  wrt$ = "SEQUENCE 1,1,1,2,16"
  CALL ibwrt(plz%, wrt$)
  wrt$ = "SEQUENCE 2,2,2,3,16"
  CALL ibwrt(plz%, wrt$)
  wrt$ = "SEQUENCE 3,3,1,0,16"
  CALL ibwrt(plz%, wrt$)
'-- Program --
  wrt$ = "PROGRAM 1"
  CALL ibwrt(plz%, wrt$)
  wrt$ = "STEP 1,0,0.00A,50mS,0,0,0,0"
  CALL ibwrt(plz%, wrt$)
  wrt$ = "EOS"
  CALL ibwrt(plz%, wrt$)
  wrt$ = "PROGRAM 2"
  CALL ibwrt(plz%, wrt$)
  wrt$ = "STEP 1,1,10.00A,10mS,1,1,0,0"
  CALL ibwrt(plz%, wrt$)
  wrt$ = "STEP ,0,10.00A,20mS,0,1,0,0"
  CALL ibwrt(plz%, wrt$)
  wrt$ = "STEP ,1,20.00A,30mS,0,1,0,0"
  CALL ibwrt(plz%, wrt$)
  wrt$ = "STEP ,1, 0.00A,40mS,0,1,0,0"
  CALL ibwrt(plz%, wrt$)
  wrt$ = "EOS"
  CALL ibwrt(plz%, wrt$)
  wrt$ = "PROGRAM 3"
  CALL ibwrt(plz%, wrt$)
  wrt$ = "STEP 1,0, 5.00A,30mS,0,1,0,0"
  CALL ibwrt(plz%, wrt$)
  wrt$ = "STEP ,0,15.00A,8000mS,0,1,0,0"
  CALL ibwrt(plz%, wrt$)
  wrt$ = "STEP ,0, 0.00A,50mS,0,1,0,0"
  CALL ibwrt(plz%, wrt$)
  wrt$ = "EOS"
  CALL ibwrt(plz%, wrt$)
  wrt$ = "PROGRAM 16"
  CALL ibwrt(plz%, wrt$)
  wrt$ = "STEP 1,0, 0.00A, 1mS,0,0,0,0"
  CALL ibwrt(plz%, wrt$)
  wrt$ = "EOS"
  CALL ibwrt(plz%, wrt$)

```

' NI mode , msec unit

' Sequence number 1

' Sequence number 2

' Sequence number 3

' Specify program number 1

' Enter data into step number 1

' Specify program number 2

' Enter data into step number 1

' Enter data into step number 2

' Enter data into step number 3

' Enter data into step number 4

' Specify program number 3

' Enter data into step number 1

' Enter data into step number 2

' Enter data into step number 3

' Specify program number 16

' Enter data into step number 1

```

'-- Write comments --
  wrt$ = "TEXTIDX" + CHR$(34) + "SAMPLE" + CHR$(34)      ' FILE INDEX <SAMPLE>
  CALL ibwrt(plz%, wrt$)
  wrt$ = "TEXTSEQ 1," + CHR$(34) + "START" + CHR$(34)   ' SEQ1 NAME <START>
  CALL ibwrt(plz%, wrt$)
  wrt$ = "TEXTSEQ 2," + CHR$(34) + "MAIN" + CHR$(34)    ' SEQ2 NAME <MAIN>
  CALL ibwrt(plz%, wrt$)
  wrt$ = "TEXTSEQ 3," + CHR$(34) + "END" + CHR$(34)     ' SEQ3 NAME <END>
  CALL ibwrt(plz%, wrt$)
  wrt$ = "TEXTPROG 1," + CHR$(34) + "LOAD0" + CHR$(34)  ' PROG1 NAME <LOAD0>
  CALL ibwrt(plz%, wrt$)
  wrt$ = "TEXTPROG 2," + CHR$(34) + "TEST1" + CHR$(34)  ' PROG2 NAME <TEST1>
  CALL ibwrt(plz%, wrt$)
  wrt$ = "TEXTPROG 3," + CHR$(34) + "TEST2" + CHR$(34)  ' PROG3 NAME <TEST2>
  CALL ibwrt(plz%, wrt$)
  wrt$ = "TEXTPROG 16," + CHR$(34) + "LOAD0" + CHR$(34) ' PROG16 NAME <LOAD0>
  CALL ibwrt(plz%, wrt$)
'-- Execute --
  wrt$ = "EXECUTE 1@"          ' Enable execution
  CALL ibwrt(plz%, wrt$)
  wrt$ = "RUN 1@"             ' Run program number 1
  CALL ibwrt(plz%, wrt$)
  wrt$ = "RUNNING?"           ' Check sequence status
  CALL ibwrt(plz%, wrt$)
  rd$ = SPACE$(20)
  CALL ibrd(plz%, rd$)
  PRINT rd$
END

```

(4) Example of program for SRQ operation

```

'<< SRQ sample >>
  REM $INCLUDE: 'qbdecl.bas'
  ON PEN GOSUB SRQ
  devname$ = "DEV1"
  CALL ibfind(devname$, plz%)
  CALL ibclr(plz%)
  wrt$ = "LOAD ON"
  CALL ibwrt(plz%, wrt$)
  wrt$ = "UNMASK 1"
  CALL ibwrt(plz%, wrt$)
  wrt$ = "FUNMASK 23"           ' Originate SRQ for FB , OHP , OCP and OV
  CALL ibwrt(plz%, wrt$)
  PEN ON

LOP:
  GOTO LOP                     ' Wait for SRQ

SRQ:
  CALL ibrsp(plz%, SPR%)      ' Process for SRQ interruption
  wrt$ = "UNMASK 0"          ' Inhibit repeated SRQ origination
  CALL ibwrt(plz%, wrt$)
  wrt$ = "HEAD 0;FAU?"
  CALL ibwrt(plz%, wrt$)
  rd$ = SPACE$(20)
  CALL ibrd(plz%, rd$)
  fau = VAL(LEFT$(rd$, 3))
  wrt$ = "LOAD OFF"
  CALL ibwrt(plz%, wrt$)
  IF fau AND 1 THEN PRINT "Overvoltage detected"
  IF fau AND 2 THEN PRINT "OCP tripped"
  IF fau AND 4 THEN PRINT "OHP tripped"
  IF fau AND 16 THEN PRINT "Fuse blown out"
END

```

4.7.3 Table of Command Headers

A table of command headers is shown below. The index numbers shown in the table conform with those used in Section 4.3.2 "Structures of Commands."

Header Name	Index No.	Header Name	Index No.
CCCR	[1]	SEQUENCE	[6]
CCRANGE	[1]	SHORT	[4]
CRRANGE	[1]	SILENT	[9]
CTRLZ	[9]	STARTTIME	[4]
CURR	[1]	STB	[10]
CV	[1]	STEP	[6]
EOS	[7]	STOP	[7]
ERR	[10]	STOALL	[5]
EXECUTE	[7]	STOMEM	[5]
FAU	[10]	STOSET	[5]
FUNMASK	[10]	STS	[10]
HEAD	[10]	SW	[4]
IDN	[10]	TERM	[10]
IRANGE	[3]	TEXTIDX	[7]
ISSET	[1], [3]	TEXTPROG	[7]
ITIME	[3]	TEXTSEQ	[7]
LLO	[8], [9]	TRG	[2]
LOAD	[1]	TRGISET	[2]
NEWSEQ	[6]	TRGPSET	[2]
PATH	[8]	TRGRSET	[2]
PAUSE	[7]	TRGVSET	[2]
POW	[1]	TRIGSTOP	[2]
PROGRAM	[7]	TRTF	[4]
PSET	[1], [3]	UNMASK	[10]
RCLALL	[5]	VOLT	[1]
RCLMEM	[5]	VSET	[1], [3]
RCLSET	[5]	VTIME	[3]
RESET	[10]	WAIT	[4]
ROOTPATH	[8]	<XOFF>	[9]
RRANGE	[3]	<XON>	[9]
RSET	[1], [3]		
RTIME	[3]		
RUN	[7]		
RUNNING	[7]		
SEI	[4]		
SEQMOD	[7]		

Chapter 5

PANEL DESCRIPTION

This chapter describes the functions of the switches, keys, indicators, and other panel items on the front and rear panels of the Electronic Load.

Contents	Page
5.1 Front Panel	5-2
5.2 Rear Panel	5-8

5.1 Front Panel

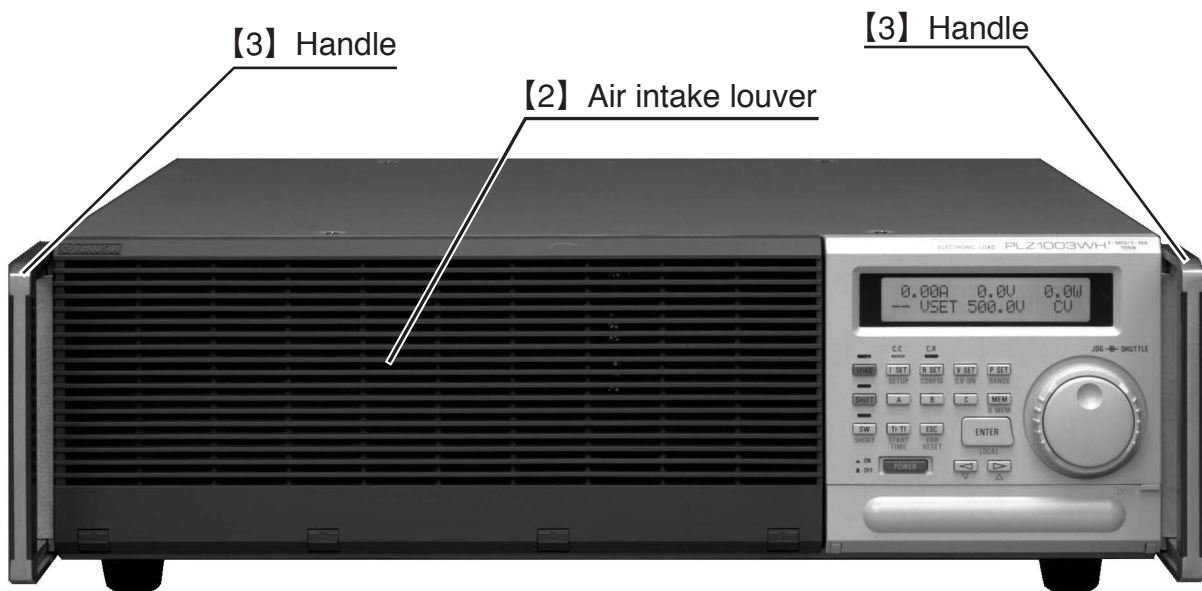
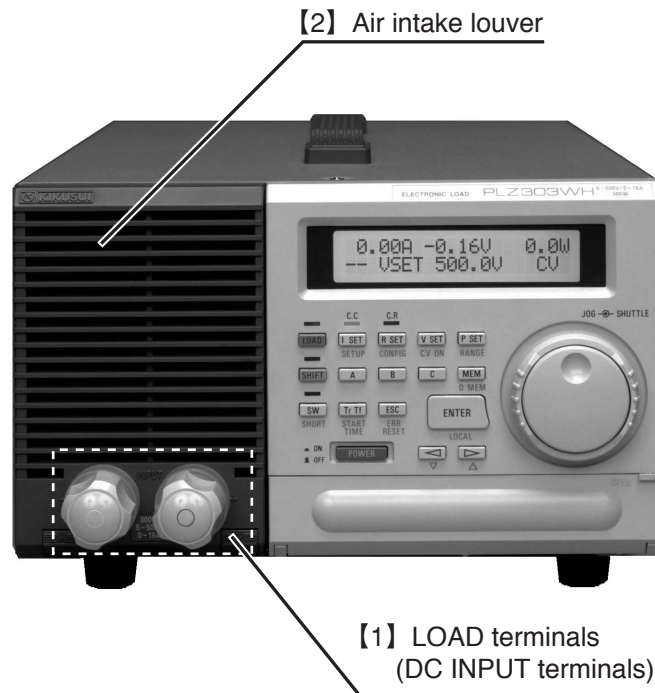

[1] LOAD terminals (for PLZ153W and PLZ303W only)

These are the DC input terminals of the Electronic Load to be connected to the equipment to be tested. These terminals are connected in parallel to those on the rear panel.

WARNINGS

- *Never touch the LOAD terminals when power is ON.*

Caution

- *Be sure to connect the wires in the correct polarity.*
- *Use sufficiently large, insulated wires.*
- *Pay attention so that no overvoltage is applied to the LOAD terminals.*

[2] Air intake louver

The louver of the cooling air intake.

Caution

- *Periodically clean the dust filter. (For the removing method of the dust filter, refer to Section 6 "MAINTENANCE AND CALIBRATION.")*
- *Pay attention so that the intaken air flow is not blocked.*

[3] Handle (for PLZ603W and PLZ1003W only)

To move the load unit, the handles should be pulled out.

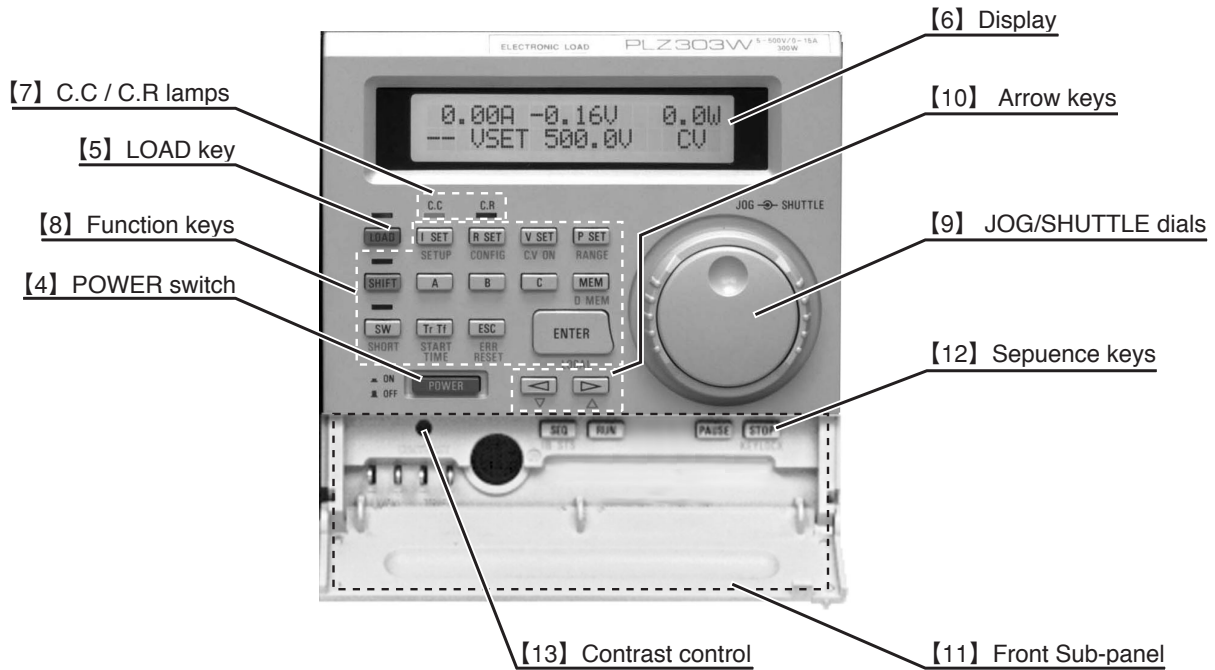

[4] POWER switch

Turns ON/OFF the AC input power of the Electronic Load.

For approximately 2 seconds after the POWER switch is turned ON, the Electronic Load performs self test. During this power-on test period, other functions of the Electronic Load are suppressed.

[5] LOAD key

Sets to the load-on state or load-off state (the Electronic Load draws or does not draw, respectively, the current). Each time as you press the key, the state changes alternately. When in the load-on state, the LED above the key illuminates.

[6] Display

Indicates current, resistance, voltage and power settings, parameters, menus, messages, etc.

Top row : Load terminal voltage, current, power, etc.

Bottom row : Mode (C.C, C.R, C.V, C.P), set values, etc.

NOTE • The in the menu type of setting, the values are indicated by using the full ranges.

[7] C.C/C.R lamps

Indicate whether the Electronic Load is in the C.C mode or C.R mode.

C.C lamp: Illuminates to denote that the C.C mode is enabled. (Enabled as you press the **[I SET]** key)

C.R lamp: Illuminates to denote that the C.R mode is enabled. (Enabled as you press the **[R SET]** key)

[8] Function keys

- [I SET]** : Enables the C.C mode. The C.C Lamp above the key illuminates denoting the C.C mode. Message [I SET] appears on the display and you can change the current setting with the JOG/SHUTTLE dials.
- [R SET]** : Enables the C.R mode. The C.R Lamp above the key illuminates denoting the C.R mode. Message [R SET] appears on the display and you can change the resistance setting with the JOG/SHUTTLE dials.
- [V SET]** : With the **[SHIFT]** + **[V SET]** (CV ON) keys, you can enable the C.V mode. Message [V SET] appears on the display and you can change the voltage setting with the JOG/SHUTTLE dials.
- [P SET]** : Enables the C.P mode. Message [P SET] appears on the display and you can change the power setting with the JOG/SHUTTLE dials.
- [SHIFT]** : This key is to shift the use of other keys. When you have pressed this key, you can select the functions indicated with blue letters below the keys.
In this manual, the key operation for selecting a blue-letter function is indicated in the format of " **[SHIFT]** + **[key top indication]** (selected function)."
- [A]** : To save data onto or recall data from memory A.
- [B]** : To save data onto or recall data from memory B.
- [C]** : To save data onto or recall data from memory C.
- [MEM]** : To enable the data save mode. When in this mode, you can save the displayed data onto memory A, B or C by pressing the corresponding key.
- [SW]** : To start/stop the switching operation. When in the switching operation, the LED above the key illuminates. (For the switching operation, refer to Section 3.5.6 "Switching Function.")
- [Tr Tf]** : If you press this key when in the C.C mode, you can change the rise up and fall down time of the current with the JOG dial.
- [ESC]** : To exit from the currently executing function. For menus, to return to the preceding menu or to a menu of an upper hierarchy.
- [ENTER]** : To enter the value. For menus, to advance to the next menu or to a menu of a lower hierarchy.
- [SHIFT]** + **[I SET]** (SETUP): To invoke the setup menu for initializing the settings or for saving data onto or recalling data from setup memory.

【SHIFT】 + 【R SET】 (CONFIG):	To invoke the configuration menu for setting of the various auxiliary functions.
【SHIFT】 + 【V SET】 (CV ON):	To enable the C.V mode
【SHIFT】 + 【P SET】 (RANGE):	To select a range for C.C or C.R mode. Ranges change between High and Low, alternately.
【SHIFT】 + 【MEM】 (DMEM):	To change only the settings on memory A/B/C, without changing the data currently employed.
【SHIFT】 + 【SW】 (SHORT):	To execute the Short action--that is, to set to the maximum current when in the C.C mode or to set to the minimum resistance when in the C.R mode.
【SHIFT】 + 【Tr Tf】 (START TIME):	To enable setting of soft start time. (Refer to [3] "Setting the soft start time" of Section 3.5.1 "C.C Mode.")
【SHIFT】 + 【ESC】 (ERROR RESET):	To reset from an alarm state.
【SHIFT】 + 【ENTER】 (LOCAL):	To change from the remote control via GPIB, MCB or RS-232C to the local control with the front panel.

[9] JOG/SHUTTLE dials

JOG dial: For fine adjustment of value.

SHUTTLE dial: For coarse adjustment of value. (The adjusting speed changes by the angle of the dial.)

[10] Arrow keys

【◀】 , 【▶】 :	To select menu items and setting items.
【SHIFT】 + 【◀】 (▽):	To select step numbers to edit programs for sequence mode of operation.
【SHIFT】 + 【▶】 (△):	To select step numbers to edit programs for sequence mode of operation.

[11] Front sub-panel

Accommodates the monitor output terminal, trigger output terminal, remote control connector and sequence keys.

I MON OUT:	Delivers a current monitor signal, which you may view on an oscilloscope or a voltmeter.
TRIG OUT:	Delivers a trigger output signal.
J1:	A special type of remote control connector, for optional RC11, RC01-PLZ, etc.

[12] Sequence keys

- 【SEQ】** : To invoke the sequence mode menu
- 【RUN】** : To execute the sequence operation
- 【PAUSE】** : To pause the sequence operation
- 【STOP】** : To stop the sequence operation
- 【SHIFT】 + 【SEQ】 (IB STS):** To display the GPIB status
- 【SHIFT】 + 【STOP】 (KEYLOCK):** To lock the keys

[13] Contrast control

Adjusts the contrast of the display.

5.2 Rear Panel

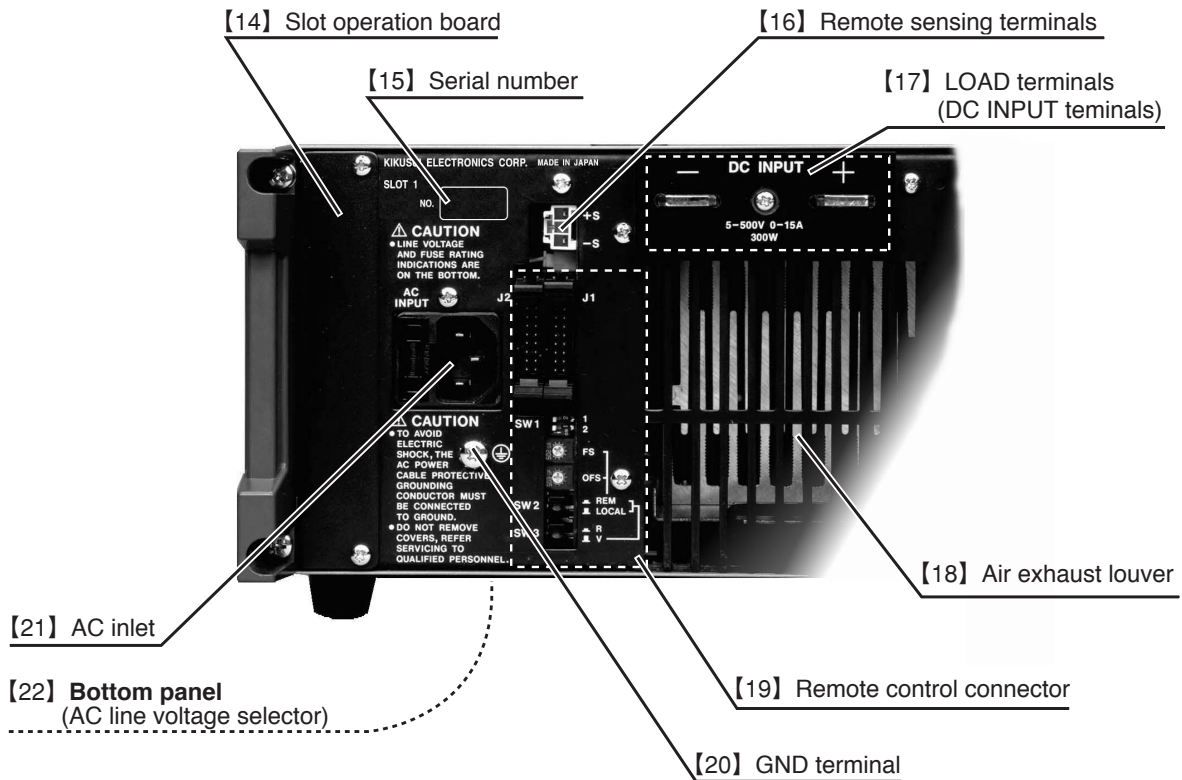

[14] Slot operation board

A slot into which the optional interface board is inserted.

To install one the following three types of optional interface boards.

- IB11 (GPIB interface board)
- RS11 (RS-232C interface board)
- MC11S (MCB interface board)

WARNINGS

- Before installing or removing an interface board, be certain that the POWER switch has been turned OFF.

[15] Serial number

The manufacturing number of your PLZ-3W series Electronic load unit.

[16] Remote sensing terminals

To connect the remote sensing wires. The remote sensing is to compensate for voltage drops that are caused by the load-connection wire resistances and contact resistances.

[17] LOAD terminals

DC INPUT terminals to be connected to the equipment to be tested.

WARNINGS

- *Never touch the LOAD terminals unless the test setup has been fully shut down.*

Caution

- *Be sure to put back the terminal cover.*
- *Securely connect the wires to the terminals by using the screws supplied accompanying the Electronic Load.*
- *Be certain that the polarity is correct.*
- *Use sufficiently heavy, insulated wires.*
- *Exercise care so that no overvoltages are applied to the LOAD terminals.*

[18] Air exhaust louver

An outlet of cooling air.

Caution

- *Note that hot exhaust air (room temperature + up to approximately 40°C) comes out of the outlet.*
- *Do not block the hot air flow that comes out of the outlet. Provide a space of 30cm or more at behind the Electronic Load.*

[19] Remote control connector

This connector is for the following types of remote control operation.

External control function

- Remote control in C.C mode with a voltage signal
- Remote control in C.C mode with a resistance signal
- Remote control in C.R mode with a voltage signal
- Remote control in C.R mode with a resistance signal
- Remote control in C.P mode with a voltage signal
- Remote control of load-on/off
- Remote control of range select
- Remote control of trigger input/output signals
- Remote control of Short output
- Remote control of parallel operation
- Remote control of alarm output

SW1-1: For master slave parallel operation, this switch of the slave unit must be set to ON.

SW1-2: This switch is reserved for system expansion and is not used in standard applications.

FS: To adjust the full scale value (maximum current or minimum resistance) for remote control mode of operation.

- OFS: To adjust the offset value (current offset or maximum resistance) for remote control mode of operation.
- SW2: To be set to REM for remote control with an external voltage signal or to LOCAL for remote control with an external resistance signal.
- SW3: To be set to V for remote control with an external voltage signal or to R for remote control with an external resistance signal.

[20] GND terminal

The safety ground of the Electronic Load

WARNINGS

- *Be sure to connect the GND terminal to an earth line when operating the Electronic Load.*

[21] AC inlet

To connect the AC input power cable. The inlet is in a unit-structure with a fuse holder and holds a spare fuse inside.

[22] AC line voltage selector

To select the AC line voltage on which the Electronic Load is to be operated.

Caution

- *Be sure to turn OFF the POWER switch and disconnect the AC input power cable before changing the selector switch.*
- *Be sure to use the correct fuse.*

Chapter 6

MAINTENANCE AND CALIBRATION

This chapter describes the maintenance, inspection, and calibration methods of the Electronic Load.

Contents	Page
6.1 Maintenance and Inspection	6-2
6.1.1 Cleaning the Front Panel	6-2
6.1.2 Cleaning the Dust Filter	6-2
6.1.3 Inspecting the AC Input Power Cable	6-3
6.1.4 Performance Test	6-3
6.1.5 Overhaul	6-4
6.2 Calibration	6-5
6.2.1 Preparation	6-5
6.2.2 Calibration Instruments	6-5
6.2.3 Calibration Setup	6-5
6.2.4 Calibration Mode Entry Procedure	6-6
6.2.5 Calibration Procedure	6-7
6.3 Before Ordering Repair Service	6-11

6.1 Maintenance and Inspection

It is most recommendable to render maintenance and calibration service for the Electronic Load at certain scheduled intervals.

6.1.1 Cleaning the Front Panel

First of all, be certain that power is turned off. To clean the front panel, wipe it lightly with a soft cloth moistened with thin neutral soapsuds.

Caution

- Do not use benzine, thinner, or other detergent. Detergent may cause discoloration of the panel surface, erasure of printed characters and marks, and clouding of the display screen.

6.1.2 Cleaning the Dust Filter

First of all, be certain that power is turned off. If the filter is clogged with dust, the cooling efficiency will be degraded and troubles may result or the life of the Electronic Load may be shortened. It is most recommendable to clean the filter periodically at certain scheduled intervals. To take out the filter to clean it, remove the louver as shown below.

■ Removing the louver

- To remove the louver, push down the nails at the bottom as shown in Figure 6.1-1 and pull the louver downward.
- For the PLZ153W and PLZ303W, remove the LOAD terminal knobs on the front panel and then remove the louver.

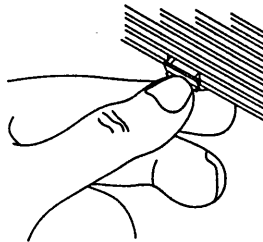

Figure 6.1-1

■ Installing the louver

- To put back the louver, mate its top protrusions into the indents of the mainframe, and fix the louver by pushing up the nails.

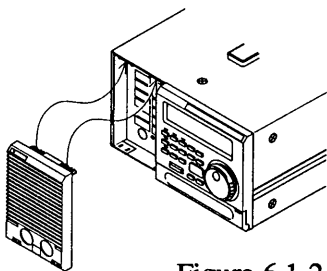

Figure 6.1-2

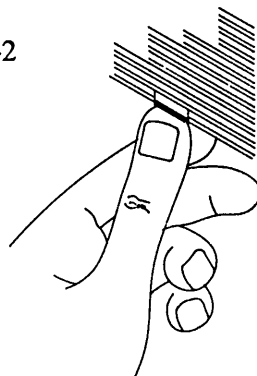

Figure 6.1-4

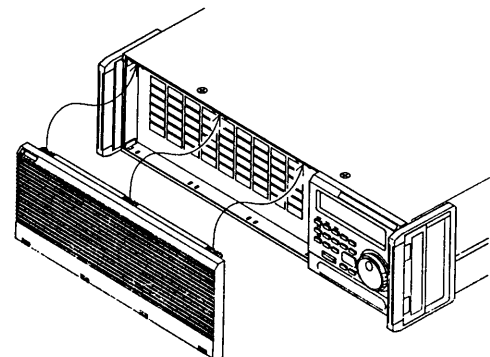

Figure 6.1-3

6.1.3 Inspecting the AC Input Power Cable

Inspect the AC input power cable for any signs of abnormality. Check that its sheath is not damaged, and that its plug is not cracked and has no loose screws.

6.1.4 Performance Test

It is most recommendable to test the performance of the Electronic Load at certain scheduled intervals.

[1] Preparation

- Allow a warm up period (stabilization period) of 20 minutes or more in order to minimize the measuring errors that could be caused by initial drifts.
- Keep the test ambient temperature stable at $23 \pm 5^\circ\text{C}$.

[2] Test devices

To test the Electronic Load, you need the following instruments:

- Shunt resistor, Class 0.1 or better, wattage meeting the rated current of Electronic Load
- DC voltmeters (DVM), accuracy 0.02% or better
- Regulated DC power supply (constant-voltage constant-current type), capable of providing the rated voltage and current of Electronic Load

[3] Test setup

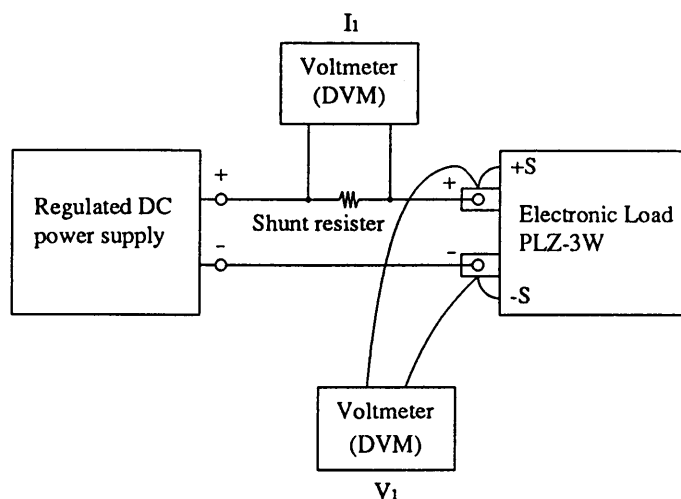

Figure 6.1-5

NOTE

- For connection of cables to the LOAD terminals, see Figure 6.1-6.
- Connect a voltmeter to the ET lug section.

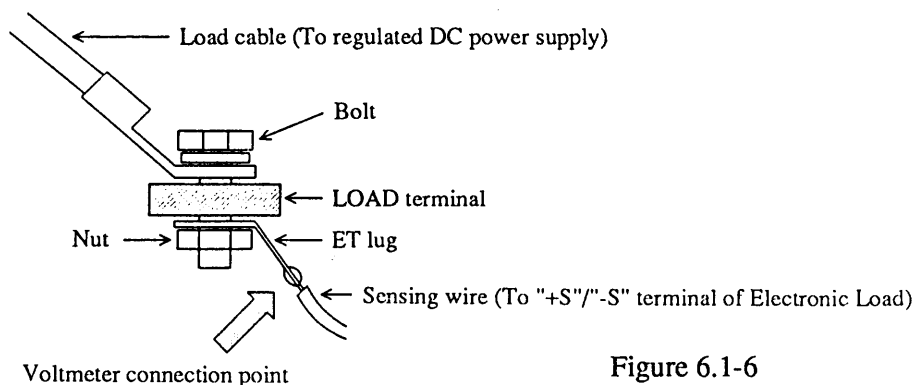

Figure 6.1-6

[4] Test procedure

Table 6.1-1

Item	Setting	Check
C.C mode test	Set the regulated DC power supply so that the LOAD terminal voltage becomes 1.5 V. Set the I SET value to the rated current. (Set the P SET value to the maximum; C.V to OFF.)	Check that " $(I \text{ SET value} - I)/(\text{Rated current})$ " is within the specified setting accuracy.
C.R mode test	Set the LOAD terminal voltage to 3.0 V and the R SET value to the minimum resistance. (Set the P SET value to the maximum; C.V to OFF.)	Check that " $(V/R \text{ SET value} - I)/(\text{Rated current})$ " is within the specified setting accuracy.
C.P mode test	Set the LOAD terminal voltage to 5.0 V and the C.P value to the rated power. (Set C.V to OFF; set the I SET to the maximum or R SET to the minimum)	Check that " $(P \text{ SET value} - V \times I)/(\text{Rated power})$ " is within the specified setting accuracy.
C.V mode test	Set the regulated DC power supply output voltage to 7 V and current to 1 A. Set C.V to ON and the V SET value to 6 V. (Set I SET value to the maximum; Set P SET value to the maximum.)	Check that " $(V \text{ SET value} - V)/(\text{Rated voltage})$ " is within the specified setting accuracy.

6.1.5 Overhaul

Certain internal components (such as electrolytic capacitors and cooling fan motor) of the Electronic Loads are wearable devices and should be replaced when a certain period has elapsed. The period typically is 10,000 running hours, although it differs depending on the conditions of use. You are recommended to order, when such period has elapsed, your Kikusui agent for overhaul of your Electronic Load.

6.2 Calibration

When you have found that the Electronic Load does not meet the specified performance by the performance test of Section 6.1.4, calibrate the Electronic Load as described in this section.

6.2.1 Preparation

- Allow a warm up period (stabilization period) of 20 minutes or more in order to minimize the measuring errors that could be caused by initial drifts.

6.2.2 Calibration Instruments

To test the Electronic Load, you need the following instruments:

- DC voltmeter, accuracy 0.01% or better
- Shunt resistor, 0.1% or better, wattage meeting the rated current of Electronic Load
- Regulated DC power supply (The Electronic Load is for wider ranges--ranging from low-voltage large-current to high-voltage small-current. Although you need a very large power supply if you want to cover the entire range with a single DC power supply, you may use two smaller DC power supplies instead--one for low-voltage large-current and the other for high-voltage small-current. For examples, you may use pairs of PAD-L Series Power supplies as shown in Table 6.2-1.)

Table 6.2-1

Calibration item	Model			
	PLZ153W	PLZ303W	PLZ603W	PLZ1003W
①~⑧、⑪、⑫ ⑮~⑲	PAD16-30L	PAD16-100L	PAD16-200L	PAD16-200L
⑨、⑩、⑬、⑭	PAD110-1.5L	PAD110-1.5L	PAD110-1.5L	PAD110-1.5L

6.2.3 Calibration Setup

- Connect voltmeter V_1 to the remote sensing terminals or directly to the LOAD terminals.
- To determine the DC input current (I_1), measure the voltage drop across the shunt resistor with the voltmeter and divide it with the resistance of the shunt resistor.

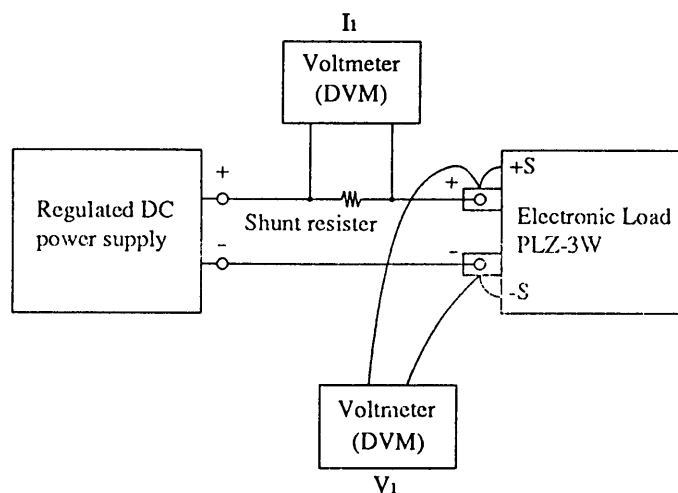

Figure 6.2-1

6.2.4 Calibration Mode Entry Procedure

- ① Press the **[SHIFT]** + **[R SET]** (CONFIG) keys to invoke the configuration menu. Select [16:] with the **[<]** and **[>]** keys.

```

>16:Calibration
      Push [ENTER]
```

- As you select [**>16: Calibration**] on the configuration menu, this display appears.

- ② Press the **[ENTER]** key.

- ③ The display for setting the ID number of the Electronic Load appears.

```

>1:Start Calibration
      ID? 0000
```

- ④ Select the ID number of the Electronic Load with the JOG/SHUTTLE dials.

Model No.	PLZ153W	PLZ303W	PLZ603W	PLZ1003W
ID No.	0153	0303	0603	1003

- ⑤ Assuming ID No. 0153, the following display will appear.

```

>1:Start Calibration
      ID? 0153
```

- ⑥ Press the **[ENTER]** key.

- If the ID number entry does not conform with the Model number, the buzzer will beep. Repeat the procedure starting by ④.

- ⑦ A display for C.C-mode H-range calibration will appear.

```

0.00A   5.00V   0.0W
--  of fsCCdaH   62
```

- A voltage of 5.00 V is applied to the LOAD terminal.
- Data 62 means that the value set when shipped from the factory or when in the previous calibration was 62.
- If you press the **[ESC]** key when in ③ through ⑦, the display of ① will resume.

NOTE

- Before turning OFF the POWER switch, be sure to return to the display of ① by pressing the **[ESC]** key. If you turn OFF the POWER switch without returning to the display of ①, the calibration procedure will be aborted and the former calibration value will resume.

6.2.5 Calibration Procedure

When in this mode, you can select calibration items with the **【◀】** and **【▶】** keys.

Calibration of offset and full-scale values for the C.C, C.R, C.V or C.P mode of operation can be done with the procedure of calibration steps ① through ⑩. When in this procedure, the value indicated on the top row of the display is that existed before calibration and may differ from that externally measured for the calibration procedure.

Calibration of the ammeter and voltmeter can be done with the procedure of calibration steps ⑪ through ⑰. The power meter is by calculation and need not be calibrated.

As you select a calibration items with the **【◀】** and **【▶】** keys, the Electronic Load automatically falls into the load-off state. You can return it to the load-on state by pressing the **【LOAD】** key.

As you change the current for calibration, the voltage at the LOAD terminal will vary due to the voltage drop in the wiring. Adjust the LOAD terminal voltage again.

In the same mode, calibrate both offset value and full-scale value. The offset calibration and full-scale calibration may mutually affect. Repeat them until both of them become satisfactory at the same time.

The top row of the display indicates the readings of the voltage, current and power actually fed to the Electronic Load. The bottom row indicates the calibration item and data which can be changed with the JOG/SHUTTLE dials.

NOTE Before starting calibration, keep record of the existing calibration value (value at bottom right).

① offsCCdaH (for offset calibration in C.C mode, H range)

0.32 A	5.00 V	1.6 W
C C o f f s C C d a H		6 2

- Press the **【LOAD】** key for load-on. Apply 5.00 V to the LOAD terminal. Adjust the current (I₁) to the value shown in Table 6.2-2 with the JOG/SHUTTLE dials.

② gainCCdaH (for rated-current calibration in C.C mode, H range)

25.20 A	5.00 V	126.0 W
C C g a i n C C d a H		2 5 2 0 5

- Press the **【LOAD】** key for load-on. Apply 5.00 V to the LOAD terminal. Adjust the current (I₁) to the value shown in Table 6.2-2 with the JOG/SHUTTLE dials.

③ offsCCdaL (for offset calibration in C.C mode, L range)

0.03 A	5.00 V	0.2 W
C C o f f s C C d a L		1 7 8

- Press the **【LOAD】** key for load-on. Apply 5.00 V to the LOAD terminal. Adjust the current (I₁) to the value shown in Table 6.2-2 with the JOG/SHUTTLE dials.

④ gainCCdaL (for maximum-current calibration in C.C mode, L range)

2.52 A	5.00 V	12.6 W
C C g a i n C C d a L		2 5 4 5 6

- Press the **【LOAD】** key for load-on. Apply 5.00 V to the LOAD terminal. Adjust the current (I₁) to the value shown in Table 6.2-2 with the JOG/SHUTTLE dials.

⑤ gainCRdaH (for minimum resistance calibration in C.R mode, H range)

25.20 A	3.00 V	75.6 W
C R g a i n C R d a H		2 1 2 9 3

- Press the **【LOAD】** key for load-on. Apply 3.00 V to the LOAD terminal. Adjust the current (I₁) to the value shown in Table 6.2-2 with the JOG/SHUTTLE dials.

⑥ gainCRdaL (for minimum resistance calibration in C.R mode, L range)

2.52 A	3.00 V	7.6 W
CR	gainCRdaL	23456

- Press the **【LOAD】** key for load-on. Apply 3.00 V to the LOAD terminal. Adjust the current (I₁) to the value shown in Table 6.2-2 with the JOG/SHUTTLE dials.

⑦ offsCVda (for offset calibration in C.V mode)

1.00 A	2.00 V	2.0 W
CV	offsCVda	-6

- In the load-off state, set the voltage of the DC power supply at 110 V and its current limit at 1.00 A. With the JOG/SHUTTLE dials, adjust so that V₁ becomes 2.00 V when **【LOAD】** key is pressed for load-on.

⑧ gainCVda (for maximum value calibration in C.V mode)

1.00 A	96.00 V	96.0 W
CV	gainCVda	21985

- In the load-off state, set the voltage of C.V gain the DC power supply at 110 V and its current limit at 1.00 A. With the JOG/SHUTTLE dials, adjust so that V₁ becomes 96.00 V when **【LOAD】** key is pressed for load-on.

⑨ offsCPda (for offset calibration in C.P mode)

0.53 A	3.00 V	1.6 W
CP	offsCPda	123

- In the load-off state, set the voltage of the DC power supply at 3.00 V. Adjust on the power supply side so that V₁ becomes 3.00 V when switched into the load-on state. With the JOG/SHUTTLE dials, adjust so that current I₁ becomes as shown in Table 6.2-2.

⑩ gainCPda (for maximum value calibration in C.P mode)

25.20 A	5.00 V	126 W
CP	gainCPda	22345

- In the load-off state, set the voltage of the DC power supply at 5.00 V. Adjust on the power supply side so that V₁ becomes 5.00 V when switched into the load-on state. With the JOG/SHUTTLE dials, adjust so that current I₁ becomes as shown in Table 6.2-2.

⑪ offsVad (for offset calibration of voltmeter)

0.00 A	1.50 V	0.0 W
CC	offsVad	1

- Press the **【LOAD】** key for load-on. Apply to the LOAD terminal a voltage so that V₁ reads 1.500 V. In this state, adjust the voltmeter reading to 1.50 V with the JOG/SHUTTLE dials.

⑫ gainVad (for maximum value calibration of voltmeter)

0.00 A	99.00 V	0.0 W
CC	gainVad	28593

- Press the **【LOAD】** key for load-on. Apply to the LOAD terminal a voltage so that V₁ reads 99.00 V. In this state, adjust the voltmeter reading to 99.00 V with the JOG/SHUTTLE dials.

- ⑬ **offsIadNorm** (for offset calibration of ammeter)
(when in single-unit operation)

0.00A	5.00V	0.0W
CC	offsIadNorm	-11

- Press the **[LOAD]** key for load-on. Apply to the LOAD terminal a voltage so that V_1 reads 5.00 V. In the load-on state, adjust the ammeter reading to 0.00 A with the JOG/SHUTTLE dials.

- ⑭ **gainIadNorm** (for maximum value calibration of ammeter)
(when in single-unit operation)

25.20A	5.00V	126.0W
CC	gainIadNorm	26671

- Press the **[LOAD]** key for load-on. Apply to the LOAD terminal a voltage so that V_1 reads 5.00 V. In the load-on state, adjust the ammeter reading to the value shown in Table 6.2-2 with the JOG/SHUTTLE dials.

- ⑮ **offsIadSum** (for offset calibration of ammeter)
(when master/slave parallel operation of two or more units)

0.00A	5.00V	0.0W
CC	offsIadSum	-12

- Press the **[LOAD]** key for load-on. Apply to the LOAD terminal a voltage so that V_1 reads 5.00 V. In the load-on state, adjust the ammeter reading to 0.00 A with the JOG/SHUTTLE dials.

- ⑯ **gainIadSum** (for maximum value calibration of ammeter)
(when master/slave parallel operation of two or more units)

6.30A	5.00V	31.5W
CC	gainIadSum	26689

- Press the **[LOAD]** key for load-on. Apply to the LOAD terminal a voltage so that V_1 reads 5.00 V. In the load-on state, adjust the ammeter reading to the value shown in Table 6.2-2 with the JOG/SHUTTLE dials.

If you press the **[ESC]** key when in a procedure within ① through ⑱, the display of [16:] of configuration menu will resume. If you press the **[ESC]** key again, the display for setting of value for the mode will appear.

Table 6.2-2

Calibration item	Model			
	PLZ153W	PLZ303W	PLZ603W	PLZ1003W
① offsCCdaH	0.32A	0.63A	1.26A	2.10A
② gainCCdaH	25.200A	50.400A	100.80A	168.00A
③ offsCCdaL	0.03A	0.06A	0.13A	0.21A
④ gainCCdaL	2.52A	5.04A	10.08A	16.80A
⑤ offsCRdaH	0.32A	0.63A	1.26A	2.10A
⑥ gainCRdaH	25.20A	50.40A	100.8A	168.0A
⑦ offsCRdaL	0.03A	0.06A	0.13A	0.21A
⑧ gainCRdaL	2.52A	5.04A	10.08A	16.80A
⑨ offsCVda	2.00V	2.00V	2.00V	2.00V
⑩ gainCVda	96.00V	96.00V	96.00V	96.00V
⑪ offsCPda	0.53A	1.05A	2.10A	3.50A
⑫ gainCPda	25.2A	50.4A	100.8A	168.0A
⑬ offsVad	1.50V	1.50V	1.50V	1.50V
⑭ gainVad	99.00V	99.00V	99.00V	99.00V
⑮ offsIadNorm	0.00A	0.00A	0.00A	0.00A
⑯ gainIadNorm	25.20A	50.40A	100.8A	168.0A
⑰ offsIadSum	0.00A	0.00A	0.00A	0.00A
⑱ gainIadSum	6.30A	12.60A	25.20A	42.00A

6.3 Before Ordering Repair Service

When the Electronic Load has become seemingly in trouble, before ordering repair service, make it sure that the cause of the failure is not a fundamental operating error on your side. Check the possible causes of troubles and take corrective measures as described below.

If the trouble is not remedied still, immediately turn OFF the power and stop using the Electronic Load. Order your Kikusui agent for repair.

[Symptoms]

No operation at all even when the POWER switch is turned on. Nothing appears on the display.

- | | |
|-------------------|---|
| [Check items] | <ul style="list-style-type: none"> • Is a correct AC line voltage supplied to the AC inlet? • Is not the fuse blown out? |
| [Probable causes] | <ul style="list-style-type: none"> • Open-circuiting of AC power cable • Blown out fuse |
| [Remedies] | <ul style="list-style-type: none"> • Replace the AC power cable. • Replace the fuse (Refer to Section 2.2.2 "Changing the AC Line Voltage Setting and Fuse.") |

[Symptoms]

The display is dark.

- | | |
|-------------------|---|
| [Check items] | <ul style="list-style-type: none"> • Is not the AC line voltage low? • Is the AC line voltage selector on the bottom panel correctly set? |
| [Probable causes] | <ul style="list-style-type: none"> • The AC line voltage is too low. • The AC line voltage selector settings is incorrect. |
| [Remedies] | <ul style="list-style-type: none"> • Provide a correct AC line voltage. • Correctly set the AC line voltage selector.
(Refer to Section 2.2 "Connecting the AC Input Power Cable.") |

[Symptoms]

The DC input current is unstable or oscillates.

- | | |
|-------------------|---|
| [Check items] | <ul style="list-style-type: none"> • Does not the load wiring has large loops? • Is not the load wiring distance long? |
| [Probable causes] | <ul style="list-style-type: none"> • The load wiring has large loops. • No remote sensing is provided. |
| [Remedies] | <ul style="list-style-type: none"> • Make use of the remote sensing function. • As required, connect a capacitor to the LOAD terminal (Refer to Section 2.4 "Load Wiring.") |

[Symptoms]

The setting value cannot be entered.

- | | |
|-------------------|---|
| [Check items] | • Is the configuration correctly set? |
| [Probable causes] | • Configuration [3: Preset] has been set to [ON]. |
| [Remedies] | • If [ON] has been set, the value can be entered with the 【ENT】 key. (Refer to Section 3.5.9 "Configuration.") |

[Symptoms]

Even when the **【A】 , **【B】** or **【C】** key is pressed, the Electronic Load does not operate with the recalled setting data.**

- | | |
|-------------------|---|
| [Check items] | • Is setting of configuration [4: Recall ABC Mem] correct? |
| [Probable causes] | • Configuration [4: Recall ABC Mem] has been set to [Safety]. |
| [Remedies] | • If it has been set to [Safety], the recalling is established by pressing the 【A】 , 【B】 or 【C】 key and then the 【ENT】 key. (Refer to Section 3.5.9 "Configuration.") |

[Symptoms]

The setting value cannot be changed by turning the JOG dial.

- | | |
|-------------------|--|
| [Check items] | • Is setting of configuration correct? |
| [Probable causes] | • Configuration [10: Resolution (I)], [11:Resolution (1/R)], [12: Resolution (V)],and [13: Resolution (P)] are set to 0. |
| [Remedies] | • Set to a value you may require. (Refer to Section 3.5.9 "Configuration.") |

Chapter 7

SPECIFICATIONS

This chapter provides tables of electrical specifications, dimensions and weights, accessories, and optional items.

Contents	Page
7.1 Electrical Specifications	7-2
7.2 Dimensions and Weights	7-8
7.3 Accessories	7-9
7.4 Optional Items	7-11

7.1 Electrical Specifications

Table 7.1-1

		PLZ153W	PLZ303W	PLZ603W	PLZ1003W	Unit	
Ratings	Operating voltage (DC)	1.5 ~ 120				V	
	Current	30	60	120	200	A	
	Power	150	300	600	1000	W	
	Minimum operation start voltage *1	0.3				V	
C.C mode	Operating range	H range	0 ~ 30	0 ~ 60	0 ~ 120	0 ~ 200	A
		L range	0 ~ 3	0 ~ 6	0 ~ 12	0 ~ 20	A
	Setting accuracy (with respect to rated current) *2	$\pm(0.3\%+30\text{mA})$	$\pm(0.3\%+60\text{mA})$	$\pm(0.3\%+120\text{mA})$	$\pm(0.3\%+200\text{mA})$	—	
	Setting resolution	H range	8	15	30	60	mA
		L range	0.8	1.5	3	6	mA
	Regulation	Against AC line voltage change *3	3				mA
		Against DC input voltage change *4	10				mA
	Temperature coefficient	± 100 of rated current (typical)				P P M / °C	
	Ripple and noise *5	RMS *6	3	5	10	20	mA
		Measured current *6	At 30 A	At 60 A	At 100 A	At 100 A	mA
		Peak to Peak *7	30	30	50	100	mA
Measured current		At 30 A	At 60 A	At 100 A	At 100 A	mA	

*1: The minimum voltage at which the Electronic Load start drawing a current.

*2: Within a range of 23°C \pm 5°C

*3: At the rated current at DC input voltage 5 V, against $\pm 10\%$ change of AC line voltage from nominal value

*4: At a current of "(rated power)/(120 V)", against DC input voltage change of 1.5 V to 120 V

*5: At DC input voltage 1.5 V, rated current

*6: 5 Hz to 500 kHz

*7: DC to 15 MHz

Table 7.1-2

		PLZ153W	PLZ303W	PLZ603W	PLZ1003W	Unit	
C.R mode	Operating range	H range	0.1 ~ 10	0.05 ~ 5	0.025 ~ 2.5	0.015 ~ 1	OHM [Ω]
			10 ~ 0.1	20 ~ 0.2	40 ~ 0.4	66 ~ 1	siemens [S]
		L range	1 ~ 100	0.5 ~ 50	0.25 ~ 25	0.15 ~ 10	OHM [Ω]
			1 ~ 0.01	2 ~ 0.02	4 ~ 0.04	6.6 ~ 0.1	siemens [S]
	Setting resolution	H range	0.25	0.5	1	2.5	millisiemens
		L range	0.025	0.05	0.1	0.25	[mS]
	Setting accuracy *1	$\pm [(1\% \text{ of reted current}) + \alpha]$ *3				—	
	Regulation	Against DC input voltage change *2	6				%
	Temperature coefficient	$\pm(1000 \text{ ppm}/^\circ\text{C} + 1 \text{ m}\Omega/^\circ\text{C})$ at minimum resistance				—	
	Ripple and noise	As shown in Graph 1 (typical)				—	

*1: At 23°C \pm 5°C, with input voltage 3 V

*2: At the minimum resistance, against input voltage change between 1.5 V to 3.0 V.

At other resistances, the setting accuracy is 6% (or better) of the maximum conductance [S] of the set range against full-range input voltage change.

With remote sensing at the load terminal.

*3: $\alpha = [3\text{V} \div \text{Set resistance}] - [3\text{V} \div (\text{Set resistance} + 8\text{m}\Omega)]$

Remarks: Conductance [S] \times Input voltage [V] = Load current [A]

Conductance [S] = 1/(Resistance [Ω])

Table 7.1-3

		PLZ153W	PLZ303W	PLZ603W	PLZ1003W	Unit
C.V mode	Operating range (DC)	1.5 ~ 120				V
	Setting accuracy *1	±0.1 of rated voltage				%
	Setting resolution	30				mV
	Input current regulation *2	0.01 of rated voltage				%
	Temperature coefficient	±100 of rated voltage (typical)				P P M/°C

* 1: Within a range of 23°C ±5°C (with remote sensing for LOAD terminal)

* 2: At input voltage 1.5 V, against current change of 10% to 100% of rated current. (with remote sensing)

Table 7.1-4

		PLZ153W	PLZ303W	PLZ603W	PLZ1003W	Unit
C.P mode	Operating range	15 ~ 150	30 ~ 300	60 ~ 600	100 ~ 1000	W
	Setting accuracy *1	±2 of rated power				%
	Setting resolution	0.025 of rated power				%
	Input voltage regulation *2	2 of rated power				%
	Ripple *3	As shown in Graph 2 (typical)				—
	Temperature coefficient	±1000 of rated power (typical)				P P M/°C

* 1: Within a range of 23°C ±5°C (with remote sensing) with DC input voltage at 5V

* 2: At rated power, against input voltage change of 6 V to 120 V (with remote sensing)

* 3: With input voltage ripple noise ≥ 5 mV

Table 7.1-5

		PLZ153W	PLZ303W	PLZ603W	PLZ1003W	Unit
Ammeter	Display digits	30.00	60.00	99.99 120.0 *2	99.99 200.0 *2	A
	Accuracy *1	± (0.25% of FS+1 digit)		± (0.25% of FS+3 digit)		—
	Temperature coefficient	±100 of FS (typical)				P P M/°C
Voltmeter	Display digits	99.99 120.0 *3				V
	Accuracy *1	± (0.2% of FS+1 digit)				—
	Temperature coefficient	±100 of FS (typical)				P P M/°C
Power meter	Display digits	150.0	300.0	600	1000	W
	The displayed value is by calculation (multiplication of current by voltage)					—

* 1: Within a range of 23°C ±5°C

* 2: To down to one place of decimal if value is greater than 100 A

* 3: To down to one place of decimal if value is greater than 100 V

Table 7.1-6

		PLZ153W	PLZ303W	PLZ603W	PLZ1003W	Unit
Tr Tf setting	Operation mode	Constant-current				—
	Setting range	50, 100, 200, 500				μ s
		1, 2, 5, 10				ms
* 1	Setting accuracy * 2	$(\pm 30\%$ of set value) $\pm 15 \mu$ s				%
Switching action	Operation mode	Constant-voltage constant-current				—
	Time setting range	1 ~ 5000				ms
	Time setting accuracy	± 5 of set value				%
Soft start action	Operation mode	Constant-current (C.C)				—
	Time setting range	0.1, 1, 2, 5, 10, 20, 50, 100				ms
	* 1	Time setting accuracy	$(\pm 30\%$ of set value) $\pm 100 \mu$ s			
Remote sensing Sensing voltage * 3		5				V
Protective features	Overcurrent protector (OCP)	Trips when the current has exceeded exceeded the rated current by approximately +5%				
	Overheat protector (OHP)	Trips to cut off the load current when the heat sink temperature has exceeded approximately 105°C				
	Reverse polarity protector	With diode and fuse				
	Power transistor protector	With fuse				
	Overvoltage protector (OVP)	Trips to turn off the load switch				

*1: Within a DC input voltage range of 3 V to 120 V. Tr (rise time) and Tf (fall time) are for 10% - 90% change of current.

*2: Setting of Tr Tf is effective when the load current change range is 2% - 100% of the rated current.

*3: Up to 2.5 V per one-way of wiring

Table 7.1-7

(Front sub-panel)

		PLZ153W	PLZ303W	PLZ603W	PLZ1003W	Unit
Current monitor terminal		1 V output at rated current				—
Remote control connector		8-pin mini-connector (can be connected to RC11 and RC02-PLZ)				
Trigger signal output terminal	Output resistance	10 k Ω				
	Output voltage	3.5 V				
	Pulse width	Approx. 10 μ s				

Table 7.1-8

(Rear panel)

		PLZ153W	PLZ303W	PLZ603W	PLZ1003W	Unit	
I/O slot		One unit of IB11, RS11 or MC11 can be installed				—	
Remote control connector	C. C/C. R voltage control terminal * 1	0 A when at 0 V, rated current when at 10 V. (C. C mode) Maximum resistance when at 0 V, minimum resistance when at 10 V. (C. R mode)				—	
	C. C/C. R resistance control terminal	Rated current when at approx. 0Ω, 0A when at approx. 10 kΩ. (C. C mode) Minimum resistance when at approx. 0Ω, maximum resistance when at approx. 10 kΩ. (C. R mode)				—	
	C. P voltage control terminal	Rated power when at approx. 10V.				—	
	Load-on/off monitor output terminal (Floating output)	Photocoupler (open collector) Rated voltage : 30 V Rated current : 5 mA				—	
	Load-on/off signal input terminal	Comparator level: Approx. 7 V. 3.3 kΩ resistor pulled up to 15 V.				—	
	Range select signal input terminal	CMOS level. 10 kΩ resistor pulled up to 5 V.				—	
	Trigger signal output terminal (Floating output)	Output resistance	10 kΩ				
		Output voltage	3.5 V				
		Pulse width	Approx. 10 μs				
	Trigger input terminal	CMOS level, pulled down with 100 kΩ				—	
Current monitor terminal(current SUM output)	1 V per rated output				—		
Short signal output	Relay contact output (25 V DC, 0.5 A)				—		

*1: The offset and full scale are adjustable.

Table 7.1-9

		PLZ153W	PLZ303W	PLZ603W	PLZ1003W	Unit															
AC line requirements	AC input voltage range	<table border="1" style="border-style: dashed; border-color: gray;"> <thead> <tr> <th></th> <th>Allowable range</th> <th>Nominal voltage</th> </tr> </thead> <tbody> <tr> <td>①</td> <td>90 ~ 110</td> <td>100</td> </tr> <tr> <td>②</td> <td>108 ~ 132</td> <td>120</td> </tr> <tr> <td>③</td> <td>180 ~ 220</td> <td>200</td> </tr> <tr> <td>④</td> <td>216 ~ 250</td> <td>240</td> </tr> </tbody> </table> Selectable with switches for ①, ②, ③ or ④.					Allowable range	Nominal voltage	①	90 ~ 110	100	②	108 ~ 132	120	③	180 ~ 220	200	④	216 ~ 250	240	V
		Allowable range	Nominal voltage																		
	①	90 ~ 110	100																		
	②	108 ~ 132	120																		
③	180 ~ 220	200																			
④	216 ~ 250	240																			
Frequency	AC 50/60 Hz				—																
Power (with GPIB board installed)	Approx. 50 (60)	Approx. 55 (65)	Approx. 70 (80)	Approx. 110 (120)	VA																
Inrush current	Approx. 18	Approx. 22	Approx. 28	Approx. 32	A																
With standing voltage	Primary to LOAD terminal	1500 V AC, for 1 minute				—															
	Primary to chassis	1500 V AC, for 1 minute				—															
Insulation resistances	Primary to LOAD terminal	≥ 30 MΩ, with 500 V DC				—															
	Primary to chassis	≥ 30 MΩ, with 500 V DC				—															
	LOAD terminal to chassis	≥ 20 MΩ, with 500 V DC				—															
Operable ambient temperature		0 to 40				℃															
Operable humidity		30 to 80 (no condensation)				% RH															
Storage ambient temperature		-20 to 70				℃															
Storage humidity		30 to 80 (no condensation)				% RH															

Table 7.1-10

	PLZ 153W	PLZ 303W	PLZ 603W	PLZ 1003W	Unit
EMC	Complied with the following standards *1 IEC61326-1:1997-03 / A1:1998-05 Electrical Equipment for Measurement, Control and Laboratory Use - EMC requirements Radiated Emissions Class A Conducted Emissions Class A IEC61000-4-2:1995-01 / A1:1998-01 Electrostatic discharge IEC61000-4-3:1995-02 Radiated, radio-frequency, electromagnetic field IEC61000-4-4:1995-01 Electrical fast transient/Burst IEC61000-4-5:1995-02 Surge IEC61000-4-6:1996-04 Conducted disturbances IEC61000-4-11:1994-06 Voltage dips, short interruptions and voltage variations				
SAFETY	Complied with the following stanterds *1 European Community Requirements (73/23/EEC)				

*1: CE marking are put only on the products sold in Europe.

■ Graph 1

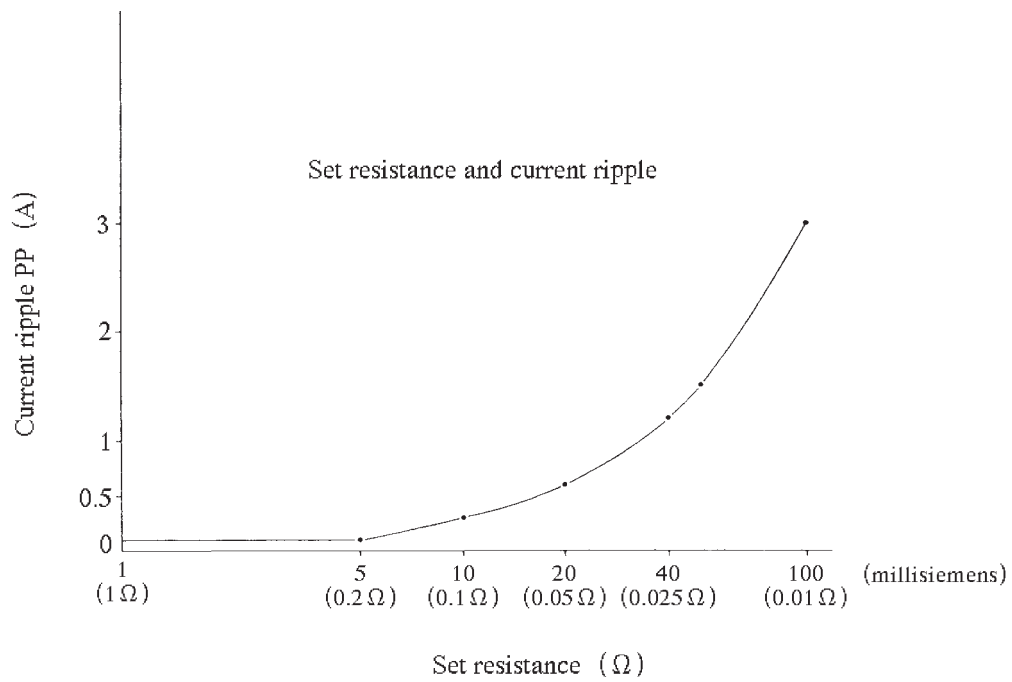

Figure 7.1-1

■ Graph 2

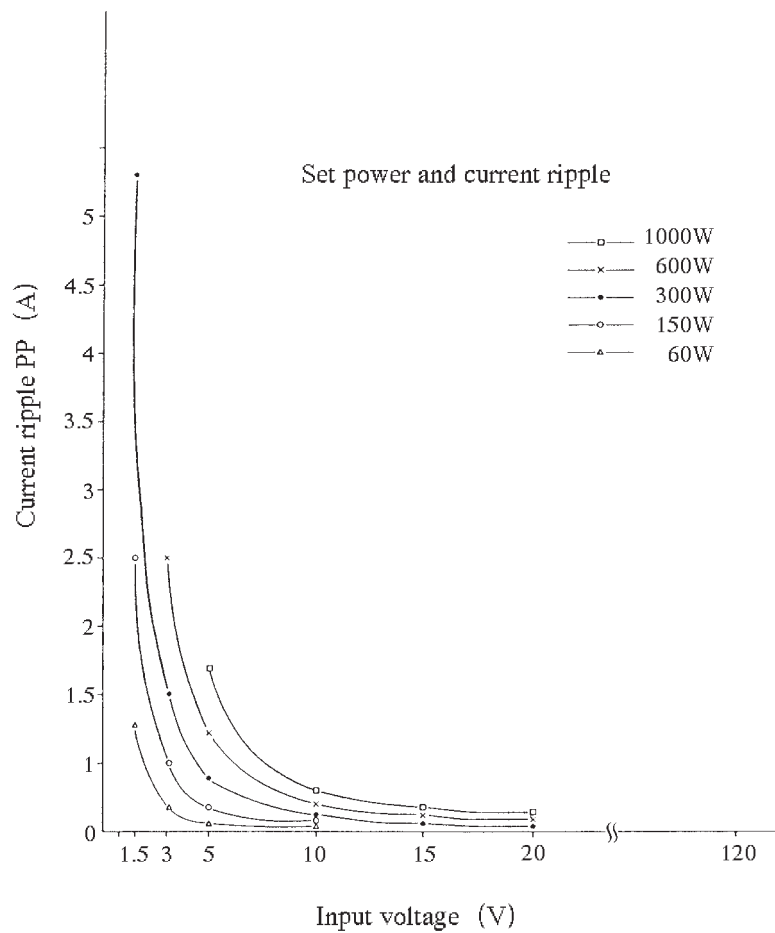
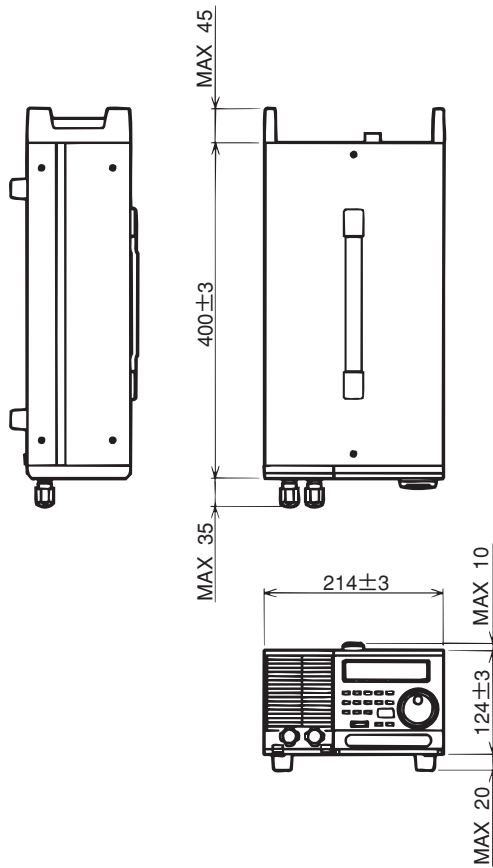

Figure 7.1-2

7.2 Dimensions and Weights



PLZ153W: Approx. 8.5 kg
 PLZ303W: Approx. 10 kg
 [UNIT : mm]

Figure 7.2-1

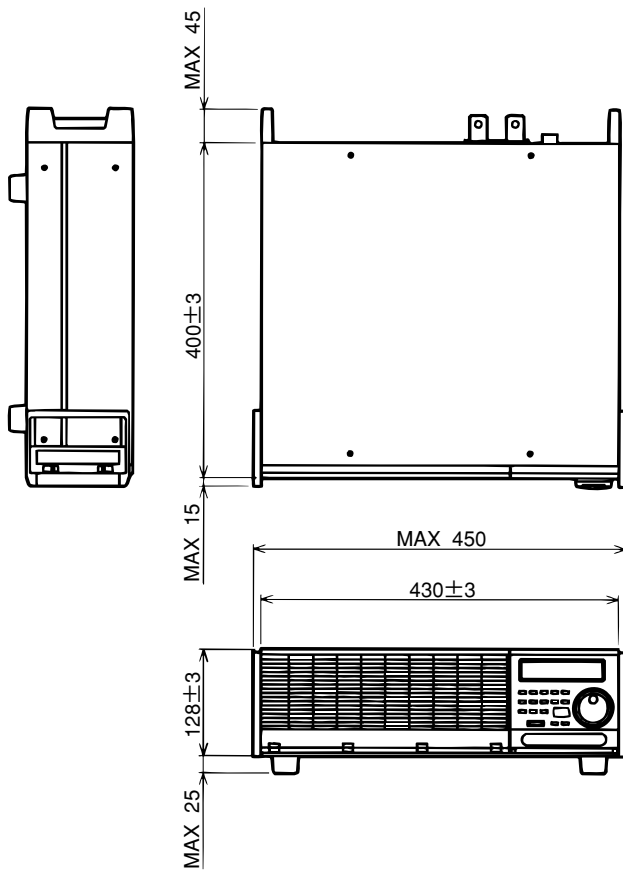

PLZ603W : Approx. 16 kg
 PLZ1003W: Approx. 19.5 kg
 [UNIT : mm]

Figure 7.2-2

7.3 Accessories

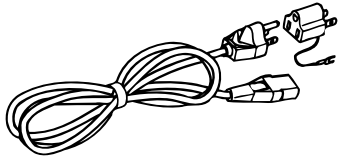

- ① AC input power cable 1 pc.
(3P-2P adaptor accompanies only
the domestic models for use in Japan.)

Figure 7.3-1

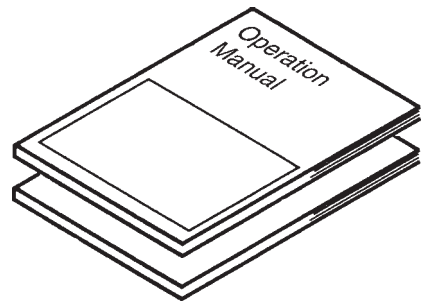

- ② Operation manual 1 copy
Sequence operation guidebook.... 1 copy

Figure 7.3-2

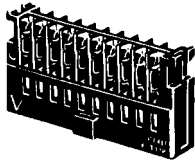

- ③ Remote control plugs 2 pcs

Figure 7.3-3

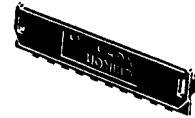

- ④ Remote control plug covers 4 pcs

Figure 7.3-4

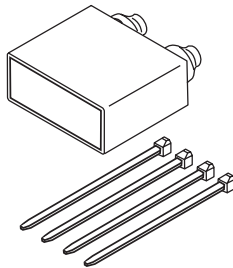

- ⑤ LOAD terminal covers 1 pc

Figure 7.3-5

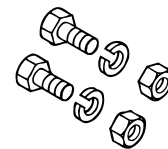

- ⑥ LOAD terminal bolts, nuts and
spring washers ... 2 pcs for each item
M6-14 (PLZ153W, PLZ303W)
M8-18 (PLZ603W, PLZ1003W)

Figure 7.3-6

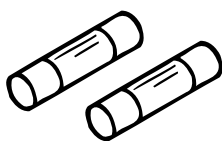

- ⑦ Spare fuses 2 pcs

Figure 7.3-7

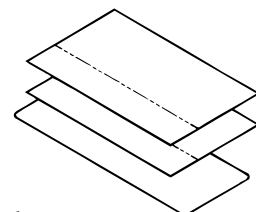

- ⑧ Seals 3 sheets

Figure 7.3-8

The fuses as shown in Table 7.3-1 accompany the Electronic Loads.

Table 7.3-1

(Fuse voltage rating : 250VAC)

	Model shipped for 100 V AC line voltage		Model shipped for 200 V AC line voltage	
	Installed in AC inlet (100 V)	Separately (200 V)	Installed in AC inlet (200 V)	Separately (100 V)
PLZ153W	1.5A (S.B) 1 pc	1A (T) 2 pcs	1A (T) 1 pc	1.5A (S.B) 2 pcs
PLZ303W	1.5A (S.B) 1 pc	1A (T) 2 pcs	1A (T) 1 pc	1.5A (S.B) 2 pcs
PLZ603W	2A (S.B) 1 pc	1.6A (T) 2 pcs	1.6A (T) 1 pc	2A (S.B) 2 pcs
PLZ1003W	3A (S.B) 1 pc	1.6A (T) 2 pcs	1.6A (T) 1 pc	3A (S.B) 2 pcs

7.4 Optional Items

■ Dedicated-type Remote Controllers

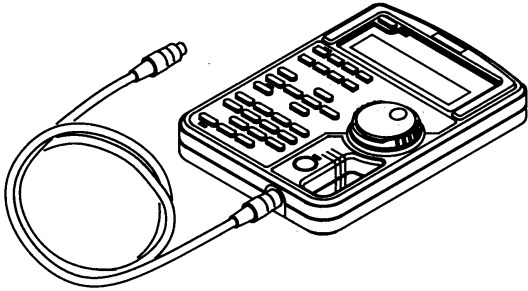

RC02-PLZ
 (For control of all functions and entry of numerical values)
 Figure 7.4-1

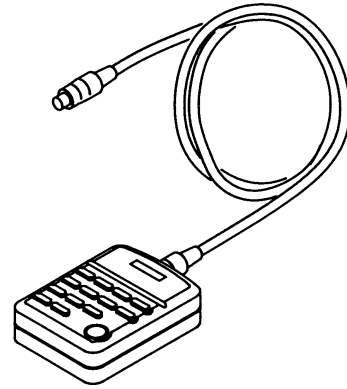

RC11
 (For entry of numerical values)
 Figure 7.4-2

■ Interface boards

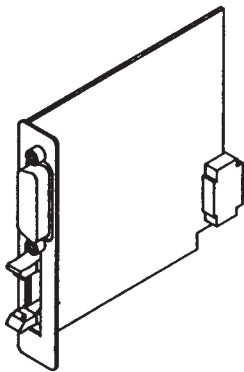

IB11
 (GPIB)
 Figure 7.4-3

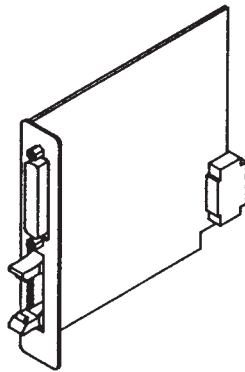

RS11
 (RS-232C)
 Figure 7.4-4

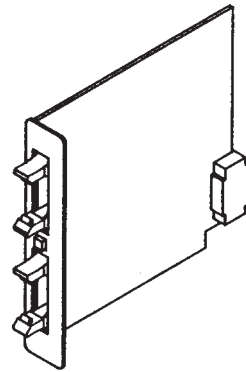

MC11S
 (MCB: Multi-channel bus)
 Figure 7.4-5

■ Rack mount frames (for PLZ153W and PLZ303W)

KRA3 (for EIA racks)

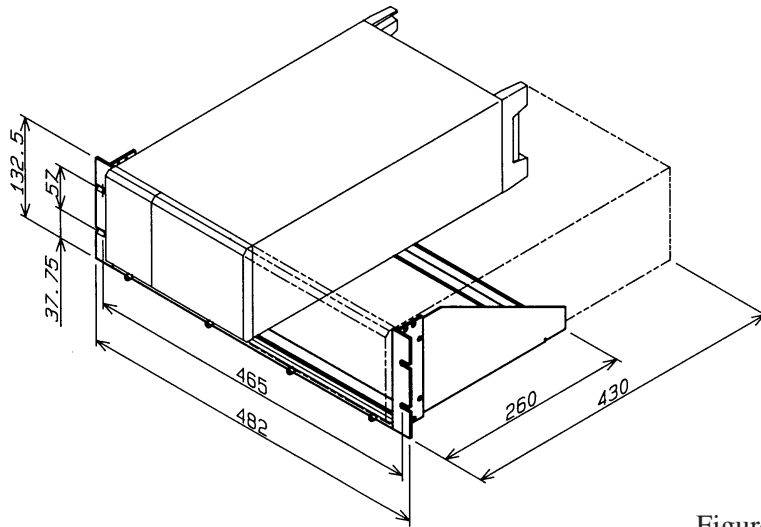

Figure 7.4-6

KRA150 (for JIS racks)

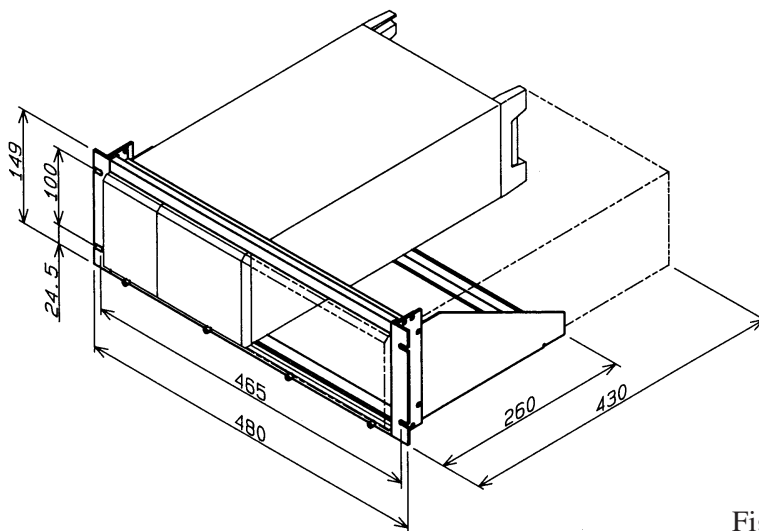
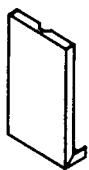

Figure 7.4-7

Blank panels (for KRA3 and KRA150)



KBP3-6 (width 1/6)

Figure 7.4-8

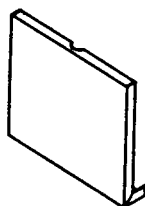

KBP3-3 (width 1/3)

Figure 7.4-9

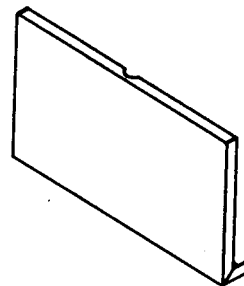

KBP3-2 (width 1/2)

Figure 7.4-10

■ Rack mount frames (for PLZ603W and PLZ1003W)

KRB3 (for EIA racks)

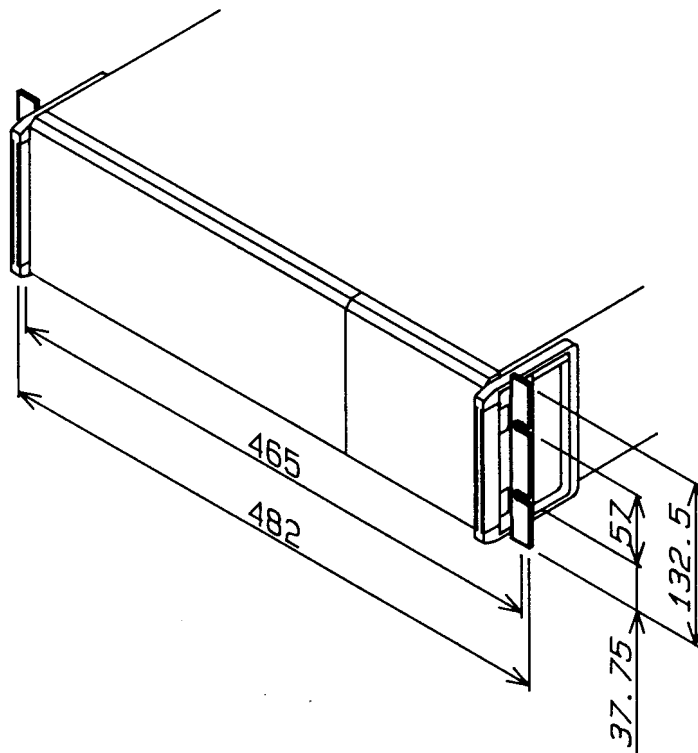

Figure 7.4-11

KRB150 (for JIS racks)

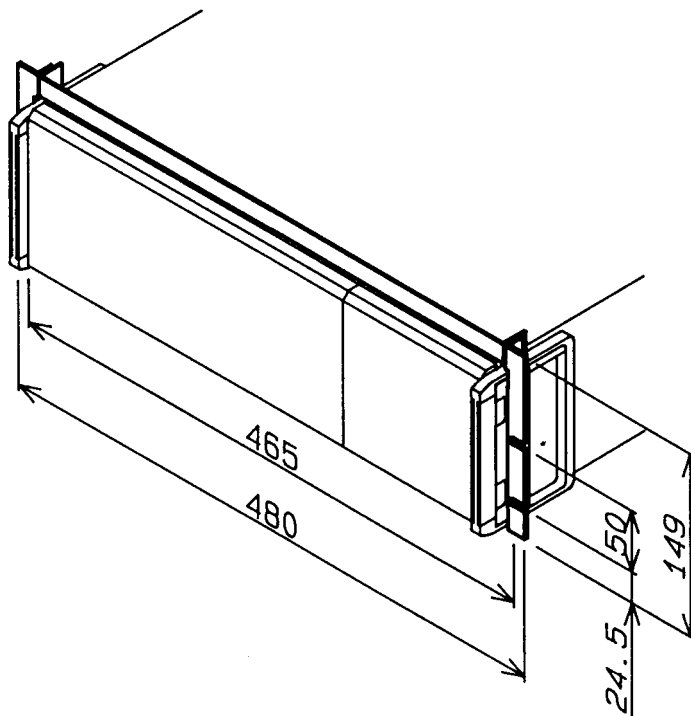

Figure 7.4-12

APPENDICES

The appendices on the following pages introduce an error message table, sequence coding sheets, and a table of functions.

Contents	Page
Appendix 1. Table of Error Messages	A-2
Appendix 2. Sequence Coding Sheets	A-6
Appendix 3. Table of Functions	A-9
Index	I - 1

Appendix 1. Table of Error Messages

Error Message	Causes and Remedies
Alarm Status	A command is attempted to be entered when in an alarm status. Eliminate the cause of the alarm, reset the alarm, and then enter the command.
Argument Err	There is an error in an argument of the command line. Specify a correct value for the argument. Be certain that the value is within the valid range.
Change To C.C Mode	There is a conflict of modes between remote sequence operation and local panel operation. Change to the C.C mode with the 【I SET】 key.
Change To C.R Mode	There is a conflict of modes between remote sequence operation and local panel operation. Change to the C.R mode with the 【R SET】 key.
Data Clip	A value greater than the rated value of the Electronic Load is specified in the sequence data. Note that the data may be clipped. Has not the range been set to L by mistake?
Diff. Mode	The setting of the basic operation mode does not conform with the command received. Select an applicable mode with a CCCRMODE command.
EXECUTE 0	The sequence operation cannot run. Perform the EXECUTE 1 command and then run the sequence.
Framing Error	A framing error occurred in RS-232C communication. There are missing bits. Check the baud rate.
Invalidity	The command entered is invalid. Check the settings now in effect.
Loop:0	The number of loops for the program is set at 0. Set it at 1 or more.

Error Message	Causes and Remedies
Memory Full	No memory space is left to write steps of sequence program. Memory capacity is for 256 steps (or 1024 steps).
Parity Error	A parity error occurred in RS-232C communication. Check the communication setup.
RAM Data Error	Data of backup memory is destroyed due to discharge of the internal battery, or data of internal RAM is destroyed. The initial data will resume. Leave the equipment in the power-on state for a while.
RX Overflow	An overflow occurred in the receiving buffer when in RS-232C communication. Check the communication setup.
SEQ Status	An invalid command is entered when in sequence operation (when in RUN or PAUSE). Stop the sequence and then enter the command.
SHORT Status	An invalid command is entered when in the Short state. Reset from the Short state and then enter the command.
SLAVE Status	An invalid command is entered when in the slave status. Reset the equipment from the slave status and then enter the command.

Error Message	Causes and Remedies
Step None	When erasing steps of sequence programs, erasure of ones which are out of the range was attempted.
Step : 0	No step area is secured for the sequence program. Secure a space with [2: Insert] which is a lower level of the edit menu.
Syntax Error	There is a syntax error in the command entered.
SW Status	An invalid command is entered when in the switching operation. Reset from the switching operation and then enter the command.
TX Overflow	An overflow occurred in the transmitting buffer when in RS-232C communication. Check the communication setup.
Warning Data	A value greater than the rated value of the equipment is specified in the sequence data. Note that the value may be clipped. Has not the range been set to Low by mistake? Is a step area secured? Is not the number of steps specified to be 0?
ALARM EXT	An external alarm signal is received.
ALARM FB1 *ALARM* FB2 *ALARM* FB3	The internal fuse has blown out. Stop using the equipment. Order your Kikusui agent for repair.
ALARM OCP	The overcurrent protector has tripped due to a load current greater than the rated current. Reduce the load current.
ALARM MCB	A message that other device is in an alarm state is received via the MCB bus.
ALARM OHP	The heat sink has been overheated. Check the cooling flow. Check the air filter for clogging.
ALARM OVER-V	An overvoltage is applied to the LOAD terminal. The internal components may be damaged. Immediately lower the voltage.
ALARM REVERSE	The voltage applied to the LOAD terminal is in the reverse polarity.

NOTE

- *The error messages enclosed in bold lines are those related to remote programming. Message [Memory Full] is either due to remote programming or due to local control from the front panel.*
- *If the same error message appears again after you have eliminated the cause of the error, order your Kikusui agent for repair.*
- *Each of the error messages related to remote programming appears for about 1.5 seconds on the display. The buzzer beeps in this case.*

Appendix 2. Sequence Coding Sheets

Coding Sheet (for Normal speed sequence)

Title: _____ Date: _____ Name: _____

Mode : NI, NR, NV, NP Description: _____

Time unit: msec sec minute hour

Sequence :

No.	Execute Program	Loop	Chain Sequence	End Program	Comments
S01	P	L	C	E	
S02	P	L	C	E	
S03	P	L	C	E	
S04	P	L	C	E	
S05	P	L	C	E	
S06	P	L	C	E	
S07	P	L	C	E	
S08	P	L	C	E	

Program No. _____

Step No.	S/R	Specified Value	Time	Trig	Load	Pause	Short	Comments

Examples of Sheet Entry

Coding Sheet (for Normal speed sequence)

Title: Example Date: _____ Name: _____

Mode : NI, NR, NV, NP Description: _____

Time unit: msec, sec, minute, hour

Sequence

No.	Execute Program	Loop	Chain Sequence	End Program	Comments
S01	P 1	L 1	C 2	E 16	
S02	P 2	L 2	C 3	E 16	
S03	P 3	L 1	C 0	E 16	
S04	P	L	C	E	
S05	P	L	C	E	
S06	P	L	C	E	
S07	P	L	C	E	
S08	P	L	C	E	

Program No. - - -

Step No.	S/R	Specified Value	Time	Trig	Load	Pause	Short	Comments
1	S	0.00A	50ms	0	0	0	0	-Program 1
1	R	10.00A	10ms	1	1	0	0	-Program 2
2	S	10.00A	20ms	0	1	0	0	
3	S	20.00A	30ms	0	1	0	0	
4	S	0.00A	40ms	0	1	0	0	
1	S	5.00A	30ms	0	1	0	0	-Program 3
2	S	15.00A	8000ms	0	1	0	0	
3	S	0.00A	50ms	0	1	0	0	
1	S	0.00A	1ms	0	0	0	0	-Program 16

Appendix 3. Table of Functions

	Function	Mode or operation			
		C. C	C. R	C. V	C. P
1. Local operation	Control from front panel	○			
	Load-on/off function	○			
	Switching function	○	○	--	--
	Soft start function	○	--	--	--
	Memory function	○			
	Setup function	○			
	Short function	○			
	Normal speed sequence function	○			
	Fast speed sequence function	○	○	--	--
	Configuration function	○			
2. Remote operation	Remote control with voltage	○	○	--	○
	Remote control with resistance	○	○	--	--
	Load-on/off function	○			
	Range select function	○	○	--	--
	Trigger signal output	○			
	Current monitor output	○			
	Short signal output	○			
	Load-on/off signal output	○			
3. Panel display	Voltmeter	○			
	Ammeter	○			
	Power meter	○			
	Mode indication	○			
	Alarm indication	○			
	GPIB status indication	○			
4. Others	Protective functions	○			
	Master/slave parallel operation	○			
	Automatic fan speed control	○			
	Remote sensing	○			
5. Optional functions	Computer control (via one of the following interfaces) GPIB (with IB11) RS-232C (with RS11) MCB (with MC11S)	○			
	Full remote control of front panel functions? (with RC02-PLZ)	○			
	Numerical value entry (with RC11 or RC02-PLZ)	○			

APPENDICES

MEMO

Index

Alphabetic order

'	4-9
?	4-9
□	4-3
「」	4-3
<>	4-3
()	4-3

(A)

ABC Key	3-34
Abnormal indications	2-8
AC inlet	5-10
AC input voltage and frequency	VI
AC line voltage selector	5-10
AC line voltage setting	2-5
AC power cable connection	V
Accessories	7-9
Accessories (illustrated)	VIII
Acknowledge message	4-7
Air exhaust louver	5-9
Air intake louver	5-3
ALARM EXT	A-4
ALARM FBI	A-4
ALARM FB2	A-4
ALARM FB3	A-4
ALARM MCB	A-4
ALARM OCP	A-4
ALARM OHP	A-4
ALARM OVER-V	A-4
ALARM REVERSE	A-4
Alarm actions and messages	3-36
Alarm buzzer	2-11
Alarm detected	3-36
Alarm input	3-60
Alarm output	3-60
Alarm Status (error message)	A-2
ALL	3-31
Ammeter calibration	3-74
Analog remote control of C.P mode	3-65
Analog remote control of C.R mode	3-63
Analog remote control, in C.C mode	3-61
Appendices	A-1

Applicable interface boards	4-3
Argument Err (error message)	A-2
Arrow keys	5-6

(B)

Back-up memory	3-31
Basic commands	4-10
Basic Operation Method	3-12
Basic rules of panel operation	3-5
Before ordering repair service	6-11
Blank panels	7-12
Board slot	5-8
Buffer	3-37

(C)

C key	5-5
C.C mode of operation	3-6
C.C/C.R lamps	5-5
C.R mode of operation	3-6
C.V mode of Operation	3-21
Calibration	3-35
Calibration Instruments	6-5
Calibration Mode Entry Procedure	6-6
Calibration Procedure	6-7
Calibration Setup	6-5
Caution sign	VII
CCRANGE	4-11
Chain sequence	3-42
Change To C.C Mode (error messages) ...	A-2
Change To C.R Mode (error messages) ...	A-2
Changing fuses	2-5
Changing the ranges, in C.C mode	3-12
Changing the ranges, in C.R mode	3-18
Characters	4-3
Cleaning the dust filter	6-2
Cleaning the front panel	6-2
Commands and control codes for	
RS-232C only	4-26
Commands and special codes for	
GPIB only	4-27
Commands for MCB only	4-25
Composition of this instruction	
manual	XI
Configuration	3-34
Connecting the AC input power cable	2-6
Connectors (accessories)	3-60
Connectors for flat cables	3-73

- Constant current (C.C) mode 3-6
- Constant power (C.P) mode 3-7
- Constant resistance (C.R) mode 3-6
- Constant voltage (C.V) mode 3-7
- Contrast control 5-7
- CRRANGE 4-11
- CTRLZ 4-26
- CURR? 4-11
- CV 4-11, 4-29, 4-30
- (D)**
- Danger signs VII
- Data 4-9
- Data Clip A-2
- DC1 4-8
- DC3 4-8
- DCL 4-27
- Delimiter 4-4
- Description of Commands 4-9
- Descriptions of Front and Rear panels 3-3
- Diff. Mode A-2
- Dimensions and weight 7-8
- Direction of socket for mating 3-73
- Display 5-4
- (E)**
- End program 3-42
- ENTER key 5-5
- Environments 2-2
- EOS 4-23
- ERR 4-24, 4-28
- ESC key 5-5
- Examples of remote programming 4-33
- EXECUTE 4-23
- EXECUTE 0 A-2
- Execution time 3-28
- Execution time of steps 3-41
- EXTALM 4-29,4-30
- External control (remote control) 3-60
- (F)**
- Factory defaults for setup 3-32
- Fast speed sequence 3-39, 3-40
- FAU 4-24, 4-28
- Fault register 4-29
- Fault unmask register 4-29
- FB 4-29, 4-30
- Features 1-3
- FI mode of sequence operation 3-40
- File 3-43
- Flat cables 3-61
- Flat cables for parallel operation 3-73
- Flow control 4-8
- Format MC 3-35
- Format of the sequence edit display 3-56
- FR mode of sequence operation 3-40
- Framing Error A-2
- Frequency response 2-14
- Frequency response when in C.C mode ... 2-14
- Frequency response when in C.R mode ... 2-14
- Front panel 5-2
- Front sub-panel 5-6
- FS 5-9
- Function keys 5-5
- Function select 3-5
- FUNMASK 4-24
- Fuse blown-out alarm 3-36
- (G)**
- GET 4-27
- GND terminal 5-10
- GPIB interface 4-4
- Ground V
- (H)**
- Handle 5-3
- HEAD 4-24
- Header 4-3
- Hierarchical menu system 3-5
- How to use the handles 2-4
- (I)**
- I MON OUT 5-6
- I SET 4-11, 4-15
- I SET key 5-5
- I SET value 3-12, 3-24
- I/F GP01 3-4
- I/F MC01 3-4
- I/F None 3-4
- I/F RS96 3-4
- IB11 4-3
- IDN? 4-24

- Inductance of load wiring 2-12
- Initial drifts 6-5
- Initial values of setup 3-32
- Initialize Setup 3-31
- Inspecting the AC input power cable 6-3
- Installing the louver 6-2
- Interface 3-35
- Interface boards 1-3
- Invalidity A-2
- IRANGE 4-15
- Items that can be set for steps 3-41
- ITIME 4-15
- (J)**
- J1 5-6
- J1, pin assignment 3-60
- J2, pin assignment 3-60
- JOG/SHUTTLE dials 5-6
- (K)**
- KBP3-2 7-12
- KBP3-3 7-12
- KBP3-6 7-12
- Keylock Function 3-30
- KRA3 7-12
- KRAI50 7-12
- (L)**
- LCD (liquid crystal display) 1-3
- LLO 4-25, 4-26
- LOAD 4-11
- LOAD key 5-4
- LOAD terminals, on front panel 5-3
- LOAD terminals 5-9
- Load wiring 2-10
- Load-on/off speed 3-20
- Load-on/off control with a contact signal 3-67
- Loop: 0 A-2
- (M)**
- Maintenance and calibration 6-1
- Maintenance and inspection 6-2
- Mark to refer to operation manual VII
- Master/Slave parallel operation 3-71
- Maximum allowable input voltage 2-10
- Maximum number of steps 3-41
- MC11S 4-3
- MCB 4-28
- MCB (multi-channel bus) 4-3
- MCB Interface 4-5
- MEM key 5-5
- Memory A 3-24
- Memory B 3-24
- Memory back-up battery 3-31
- Memory C 3-24
- Memory commands 4-14
- Memory full A-3
- Memory function 3-24
- Menu for store/Recall of setups 3-31
- Minimum operable voltage 2-11
- Mode indication 3-11
- Modes of operation 3-6
- Monitor output 3-60
- (N)**
- NEWSEQ 4-21
- NI mode of sequence operation 3-40
- Normal indications 2-7
- Normal speed sequence 3-39
- NP mode of sequence operation 3-40
- NR1 4-9
- NR2 4-9
- NR3 4-9
- NR4 4-9
- Number of loops 3-41
- Number of programs 3-41
- Number of sequences 3-41
- NV mode of sequence operation 3-40
- (O)**
- OCP 4-29
- OHP 4-29
- Operable range of Electronic Load 3-8
- Operating point of Electronic Load 3-8
- Operation error 3-5
- Optional items 7-11
- Outline 1-2
- OV 4-29
- Overcurrent alarm 3-36
- Overhaul 6-4
- Overheat 3-36
- Overshoot 3-23

Overvoltage	2-12	RAM Data Error	A-3
Overvoltage alarm	3-36	Range select signal	3-60
(P)			
P SET	4-11, 4-15	Rated current	3-8
P SET key	5-5	Rated power	3-8
P SET value	3-12, 3-24	Rated voltage	3-8
Packed states of Electronic Loads	VIII	Ratings of the contact signal	3-37
Packing for re-shipment	X	RCLALL	4-19
Panel Description	5-1	RCLMEM	4-19
Parallel Ope	3-35	RCLSET	4-19
Parallel operation	3-71	Rear panel	5-8
Parity Error	A-3	Recall ABC Mem.	3-34
PAUSE key	3-45, 5-7	Recall ALL	3-31
Pause of sequence operation	3-45	Recall MEM	3-31
Performance test	6-3	Recall SET	3-31
Performance test procedure	6-4	Recalling data from memory	3-27
Photocoupler	3-67	Receiving inspection	VIII
Polarity	2-10	SRQ, Status Bytes, and Registers	4-31
PON	4-28	Remote control connector	5-9
POW	4-11	Remote control of load ON/OFF	3-66
POWER switch	3-4, 5-4	Remote control of range select	3-68
Power	4-9	Remote programming	4-1
Power-on check procedure	2-7	Remote sensing	2-13
Power-on Keylock	3-34	Remote sensing terminals	5-9
Power-on Load	3-34	Removing the louver	6-2
Power-on SRQ (SRQ ???)	4-4	Request to send	4-8
Precautions for moving the		Request to stop sending	4-8
Electronic Load	2-4	RESET	4-24
Preset	3-34	Reset from pause	3-45
PROGRAM	4-23	Reset from pause by trigger input	3-41
Program edit display	3-51	Resistance signal for remote control	3-60
Program message	4-6	Resolution 1/R	3-35
Program number	3-42	Resolution I	3-35
Programming format	4-6	Resolution P	3-35
Programs	3-42	Resolution V	3-35
Protection features	2-10	Response message	4-7
(Q)			
Query message	4-6	REV	4-29
(R)			
R SET	4-11	Reverse voltage alarm	3-36
R SET key	5-5	ROM Version Number	I, 2-7
R SET value	3-12, 3-24	ROOTPATH	4-25
Rack mount frames	7-12, 7-13	RQS	4-28
		RRANGE	4-15
		RS-232C Interface	4-4
		RS11	4-3
		RTME	4-15
		RUN	4-23
		RUN key	5-7
		RUNNING	4-23
		RX Overflow	A-3

(S)

Saving data onto memory	3-24	Short function	3-37
SDC	4-27	Short output	3-60
SE	4-28	SILENT	4-26
Selecting a Tr Tf value	3-15	SLAVE Status	A-3
SEQ key	5-7	Slot for optional interface boards	5-8
SEQ Status	A-3	sp	4-9
SEQMOD	4-23	Special function commands	4-19
SEQUENCE	4-21	Specifications	7-1
Sequence Coding Sheets	A-6	SRQ (SRQ ???)	4-31
Sequence commands	4-20	STALL	4-19
Sequence execution memory	3-48	STARTTIME	4-17
Sequence files	3-43	Status byte register	4-28
Sequence keys	5-7	Status bytes	4-31
Sequence operation	1-3, 3-39	STB	4-24
Sequence operation execution	3-44	STEP	4-21
Sequence operation menu	3-47	Step None	A-4
Sequences	3-42	Step transition	3-44
Serial number	5-8	Step : 0	A-4
SET	3-31	Steps	3-42
Setting the I SET value	3-12	STOMEM	4-19
Setting the P SET value	3-23	STOP	4-23
Setting the R SET value	3-18	STOP key	3-46, 5-7
Setting the soft start time	3-16	Store ALL	3-31
Setting the V SET value	3-21	Store MEM	3-31
Setting Tr Tf	3-15	Store SET	3-31
Settings for sequence operation	3-47	STOSET	4-19
Setup commands	4-19	string	4-9
Setup data items	3-31	STS?	4-24
Setup function	3-5, 3-31	SW	4-17
SHIFT + ENTER key	5-6	SW Key	3-34, 5-5
SHIFT + ESC keys	3-37, 5-6	SW status	A-4
SHIFT + MEM keys	3-24, 5-6	SW Trig Out	3-35
SHIFT + P SET keys	5-6	SW1-1	5-9
SHIFT + R SET keys	3-34, 5-6	SW1-2	5-9
SHIFT + SEQ keys	5-7	SW2	5-10
SHIFT + SETUP keys	3-33	SW3	5-10
SHIFT + STOP keys	3-30, 5-7	Switching execution time	3-24
SHIFT + SW keys	3-37, 5-6	Switching function	3-28
SHIFT + Tr Tf keys	3-17, 5-6	Switching operation	3-28
SHIFT + V SET keys	5-6	Switching the load ON/OFF, in C.C mode	3-13
SHIFT key	3-5, 5-5	Switching the load ON/OFF, in C.R mode	3-18
SHIFT + I SET keys	5-5	Switching to load-on, in C.P mode	3-23
SHORT	3-37	Switching to load-on, in C.V mode	3-21
SHORT key	3-35	Syntax Error	A-4
SHORT Status	A-3	System commands	4-24

(T)

Table of Command Headers	4-38
Table of error codes	4-32
Table of error messages	A-2
Table of Functions	A-9
TERM	4-24
TEXTIDX	4-23
TEXTPROG	4-23
TEXTSEQ	4-23
To add steps	3-54
To check step data	3-54
To create programs	3-50
To delete step data	3-54
To edit sequences	3-50
To modify steps	3-54
To prevent oscillation	2-14
To recall a setup	3-33
To reset from alarm	3-37
To run a program	3-58
To run a sequence	3-58
To simulate a load	1-2
To store a setup	3-33
Tr Tf key	5-5
TRG	4-13
TRIG OUT	5-6
Trigger input signal	3-60
Trigger output signal	3-60
Trigger setting command	4-13
Trigger signals	3-69
TRIGSET	4-13
TRIGSTOP	4-13
TRIGVSET	4-13
TRTF	4-17
TX Overflow	A-4
Types of sequence operation	3-40

(U)

UNMASK	4-24
Unmask register	4-28

(V)

V SET key	5-5
V SET value	3-12, 3-24
VOLT?	4-11
Voltage drop in the load wiring	3-19

Voltage signal for C.C	3-60
Voltage signal for C.P remote control	3-60
Voltage signal for C.R	3-60
VSET	4-11
VTIME	4-15

(W)

WAIT	4-17
Warming up	6-5
WARNING	VII
Warning Data	A-4
WARNINGS AND CAUTIONS	V
Wire gauges (amperage)	2-11

(X)

XOFF	4-26
XON	4-26