



**Advanced Test Equipment Rentals**  
**www.atecorp.com 800-404-ATEC (2832)**



097-55300-01  
Issue 1: Mar 00

# 55300A

## GPS TELECOM PRS USER'S GUIDE

This guide describes how to install, use, and service the 55300A GPS Telecom Primary Reference Source. The information in this guide applies to instruments having the number prefix listed below, unless accompanied by a “Manual Updating Changes” package indicating otherwise.

**SERIAL PREFIX NUMBER: 3602, 3612, KR841 and above**

**FIRMWARE REVISION: 3639 and above**

Firmware revision can be identified by using the RTRV-NETTYPE TL1 command via the **REMOTE ACCESS PORT** or **PORT 1** of the 55300A. Using the \*IDN? command via **TIME OF DAY** RS-232C port, also identifies the Firmware revision. Refer to this guide for instructions on connecting computer or terminal to this product.

For assistance, contact:

Symmetricom, Inc.  
2300 Orchard Parkway  
San Jose, CA 95131-1017

U.S.A. Call Center:  
888-367-7966 (from inside U.S.A. only –  
toll free)  
408-428-7907

U.K. Call Center:  
+44.7000.111666 (Technical Assistance)  
+44.7000.111888 (Sales)  
+44.1604.586740

Fax: 408-428-7998

E-mail: [ctac@symmetricom.com](mailto:ctac@symmetricom.com)

Internet: <http://www.symmetricom.com>

## Warning Symbols That May Be Used In This Book



Instruction manual symbol; the product will be marked with this symbol when it is necessary for the user to refer to the instruction manual.



Indicates hazardous voltages.



Indicates earth (ground) terminal.



or



Indicates terminal is connected to chassis when such connection is not apparent.



Indicates Alternating current.



Indicates Direct current.

---

# Contents

## In This Guide

<b>Guide Organization</b>	<b>xiii</b>
<b>Description of the 55300A GPS Telecom Primary Reference Source</b>	<b>xiv</b>
Overview	xiv
Operation	xiv
Control and Communications	xv
Physical Description	xv
Front Panel of 55300A Module	xvi
Connectors and Controls	xvi
Indicators	xvi
Rear Panel of the 55310A Rack Mount Shelf	xvi
Top Front Panel of 55320A/55322A Rack Mount Shelf	xvii
<b>Options</b>	<b>xviii</b>
Frequency Outputs (Selection Made When You Ordered the 55300A)	xviii
NEBS (US) Version	xviii
ETSI (International) Version (Balanced Outputs)	xviii
ETSI (International) Version (Unbalanced Outputs)	xix
<b>Accessories Supplied and Available</b>	<b>xix</b>
Accessories Supplied	xix
Accessories Available	xix
Telecom Accessories	xix
GPS Accessories	xix
Serial Interface Accessories	xx
<b>Manuals</b>	<b>xxi</b>
Supplied Manuals	xxi
Available Documents	xxi

## 1 Getting Started

<b>55300A Front Panel at a Glance</b>	<b>1-2</b>
<b>55300A/55310A Rear Panel at a Glance</b>	<b>1-4</b>
<b>55300A/55320A and 55300A/55322A Top Front Panels at a Glance</b>	<b>1-6</b>
<b>55310A, 55320A, 55322A Rack Mount Shelves at a Glance</b>	<b>1-8</b>
<b>Preparing the 55300A for Use</b>	<b>1-9</b>
To Install the 55300A into a Rack Mount Shelf	1-9
To Assemble and Install the Antenna System	1-10
To Connect DC Power	1-10

- Power Requirements 1-10
- Current Demands 1-10
- Connecting DC Power If No Power Cables Exist 1-11
- Connecting DC Power Using Existing Site Power Cables 1-13
- Connecting the 55300A to a Terminal or Computer 1-14**
  - To Configure Terminal Communications for Windows-based PC 1-17
  - To Configure Terminal Communications for DOS-based Only PC (No Windows) 1-18
  - To Configure Terminal Communications for HP 200LX (or Equivalent) Palmtop 1-19
- Powering Up the 55300A 1-20**
  - Overview of the Power-Up Procedure (What to Expect) 1-20
  - To Power Up the 55300A 1-20
  - To Send TL1 or SCPI Command to Obtain 55300A GPS Status 1-22
    - Using TL1 Commands to Obtain 55300A GPS Status 1-22
    - Using SCPI Commands to Obtain 55300A GPS Status 1-23
  - To Understand the Receiver Status Screen Data 1-24
- Installing the Automated SatStat Program for Continual Status Updates 1-25**
- Operating the Automated SatStat Program 1-26**
- Customizing the 55300A Operation 1-27**
- Using Commands to Control Key Functions (Examples) 1-28**
  - To Perform Basic Installation and Simple Customizing 1-28
    - If required, restore all of the 55300A's internal settings to their factory shipment values by invoking a system preset. 1-28
    - Initiate "surveying", an automatic determination of the 55300A's antenna position. 1-29
    - Set the 55300A to compensate for the length of the antenna cable. 1-29
    - Set the 55300A to exclude satellites which appear below a specified elevation angle. 1-30
    - Set the 55300A to display local time rather than UTC time. 1-30
  - To Install With a Limited View of the Sky,
  - To Bypass Position Survey Operation 1-30

## 2 Acceptance Test

### Introduction 2-2

Operational Verification 2-2

Acceptance Test 2-2

Test Record 2-2

### Test Equipment Required 2-3

#### 55300A Operational Verification 2-4

Introduction 2-4

Preliminary Test Setup 2-4

10 MHz Verification 2-6

1 PPS Verification 2-6

Time of Day RS-232 Serial Interface Verification 2-7

### In Case of Difficulty 2-8

#### 55300A Acceptance Test 2-8

Testing Requirements 2-8

About the Acceptance Test 2-8

#### 2048 kbps and 2048 kHz Tests—55300A/55320A/55322A

##### Version Only, G703.6/G703.10 2-10

Test 1: 2048 kbps—Using the Waveform Mask Capability of the HP 54520A/C (or Equivalent) Oscilloscope 2-10

Test 2: 2048 kHz—Using the Waveform Mask Capability of the HP 54520A/C (or equivalent) Oscilloscope 2-11

Telecom Masks and HP 54520A/C (or Equivalent) Oscilloscope Setups 2-12

Test 1: 2048 kbps Test—Using an HP 54600B (or Equivalent) Oscilloscope Without Waveform Mask Capability 2-15

Test 2: 2048 kHz Test—Using an HP 54600B (or Equivalent) Oscilloscope Without Waveform Mask Capability 2-17

#### 1544 kbps and 1544 kHz Tests—55300A/55310A (T1) Version Only, G703.4/G703.10 2-20

Test 1A: 1544 kbps Test—Using the Waveform Mask Capability of the HP 54520A/C (or Equivalent) Oscilloscope 2-20

Test 2A: 1544 kHz Test—Using the Waveform Mask Capability of the HP 54520A/C (or Equivalent) Oscilloscope 2-21

Test 1A: 1544 kbps Test—Using an HP 54600B (or Equivalent) Oscilloscope Without Waveform Mask Capability 2-22

Test 2A: 1544 kHz Test—Using an HP 54600B (or Equivalent) Oscilloscope Without Waveform Mask Capability 2-24

<b>55300A Acceptance Test Record (Page 1 of 2)</b>	<b>2-27</b>
<b>55300A Acceptance Test Record (Page 2 of 2)</b>	<b>2-28</b>

### **3 Features and Functions**

#### **Chapter Contents 3-2**

#### **Inputs 3-4**

GPS ANTENNA Input	3-4
Recommended Antenna Cable Assemblies	3-4
Antenna Cable Length Delay	3-5
POWER A and B -48 VDC Inputs	3-7
ESD Chassis Ground Connection	3-7

#### **Telecommunication Frequency Outputs 3-8**

MONITOR Output	3-9
DS1 Wire-Wrap Connector Outputs (55300/55310A Only)	3-9
Output A and B (55300A/55310A Only)	3-10
2048 kbps Outputs (55300A/55320A/55322A Only)	3-11
2048 kHz Outputs (55300A/55320A/55322A Only)	3-13
Squelched	3-13
Continuous	3-13

#### **Time and Frequency Outputs 3-14**

10 MHz Output	3-14
1 PPS (One Pulse Per Second) Output	3-14
IRIG-B Output	3-14
1 PPS Wire-Wrap Connector Outputs (55300/ 55310A Only)	3-16
1 PPS Negative and Positive Outputs (55300A/55320A/ 55322A Only)	3-16
1 PPS BNC Outputs (55300A/55320A Only)	3-16
1 PPS Pair of DE-9S Subminiature D Connector Outputs (55300/55322A Only)	3-17

#### **Indicators 3-18**

Power Indicator	3-18
GPS Lock Indicator	3-18
Holdover Indicator	3-18
Critical Alarm Indicator	3-19
Major Alarm Indicator	3-19
Minor Alarm Indicator	3-19
ACO Active Indicator	3-19

#### **Controls 3-20**

ACO Pushbutton Control	3-20
ACO Reset Pushbutton Control	3-20

Local (with ACO) Alarm Control Wire-Wrap Connectors (55300A/55310A Only)	3-20
Remote Alarm Control Wire-Wrap Connectors (55300A/ 55310A Only)	3-21
<b>ALARMS Connector (55300A/55320A/55322A Only)</b>	<b>3-22</b>
<b>RS-232 Serial Interface Ports, Input/Output (I/O)</b>	<b>3-24</b>
REMOTE ACCESS PORT RS-232 Serial Interface Port	3-24
PORT 1 Front-Panel RS-232 Serial Port	3-25
TIME OF DAY Rear-Panel RS-232 Serial Port	3-26
<b>Connecting a Terminal/Computer or Modem</b>	<b>3-27</b>
To Connect the 55300A to a Terminal Via REMOTE ACCESS PORT Serial Port	3-28
To Connect the 55300A to a Modem Via REMOTE ACCESS PORT Serial Port	3-28
To Connect the 55300A to a Terminal Via PORT 1 Serial Port	3-29
To Connect the 55300A to a PC Via TIME OF DAY Serial Port	3-30
To Connect the 55300A to a Palmtop Computer	3-31
Connecting to the TIME OF DAY Port	3-31
Connecting to the REMOTE ACCESS PORT	3-31
<b>Making Your Own RS-232 Cables</b>	<b>3-32</b>
<b>Configuring the RS-232 Port(s)</b>	<b>3-33</b>
If You Need to Make Changes to the Serial Port Settings	3-34
Configuring REMOTE ACCESS PORT	3-35
Configuring PORT 1	3-35
Configuring TIME OF DAY Port	3-35
If Changes Have Already Been Made to the Serial Port Settings	3-36
To Restore RS-232 Serial Port Factory-Default Values	3-37
<b>Setting Up Security</b>	<b>3-39</b>
To Enable Security	3-39
To Disable Security	3-41
<b>Operating Concepts</b>	<b>3-42</b>
General	3-42
Holdover Description	3-42
Understanding AIS, Squelched, and Continuous	3-43
AIS	3-43
Squelched	3-43
Continuous	3-43
Holdover Action of the Telecommunication Outputs	3-43
Holdover Duration Exceeded	3-44
Powerup	3-44

	Preset	3-44
	Action Command	3-44
	<b>In Case of a Problem</b>	<b>3-45</b>
	Hours after powerup, 55300A not establishing GPS lock	3-45
	55300A not maintaining GPS lock	3-46
<b>4</b>	<b>Using the Receiver Status Screen</b>	
	<b>Chapter Contents</b>	<b>4-2</b>
	<b>Using and Reading the Receiver Status Screen</b>	<b>4-3</b>
	Tutorial on Using the Status Screen to Interface With the 55300A	4-3
	Demonstration of Holdover Operation	4-8
	<b>Receiver Status Screen Data</b>	<b>4-11</b>
	SYNCHRONIZATION Section of the Status Screen	4-12
	SYNCHRONIZATION Summary Line	4-12
	SmartClock Mode	4-12
	Reference Outputs	4-13
	ACQUISITION Section of the Status Screen	4-14
	ACQUISITION Line	4-14
	Tracking, Not Tracking	4-14
	Time	4-16
	Position	4-17
	HEALTH MONITOR Section of the Screen	4-18
	<b>The Receiver Status Screen at a Glance</b>	<b>4-19</b>
		<b>4-22</b>
<b>5</b>	<b>Specifications</b>	
	<b>Introduction</b>	<b>5-2</b>
<b>6</b>	<b>Maintenance</b>	
	<b>Chapter Contents</b>	<b>6-2</b>
	<b>Pre-Troubleshooting Information</b>	<b>6-3</b>
	Safety Considerations	6-3
	Recommended Test Equipment	6-3
	Repair Considerations	6-4
	Electrostatic Discharge	6-4
	Disassembly and Reassembly Specifics	6-4
	After Service Considerations	6-4
	Assembly Identification and Location	6-5
	<b>Troubleshooting the 55300A</b>	<b>6-7</b>
	Troubleshooting Strategy	6-7
	To Isolate Problems Using SatStat Health Monitor and Diagnostic Log Features	6-8



- Using the HEALTH MONITOR Section of the Receiver Status Screen 6-8
- Using the SYNCHRONIZATION Section of the Receiver Status Screen 6-9
- Using the Diagnostic Log of SatStat Program 6-9
- To Isolate GPS Antenna and Accessories 6-10
- To Isolate A1 Main Board and A2 DC-DC Power Supply Board 6-12
- Switch or Jumper Wire Configuration Check 6-17
  - Exchanged A1 Main Boards Are Configured for Option 104 or Option 271 6-17
  - S2 and S3 Switch Configuration Summary 6-18
- Replacing Assemblies 6-23**
  - Tools Required 6-23
  - To Remove Module From Rack Mount Shelf 6-23
  - To Remove A1 Main Board Assembly 6-24
  - To Remove A2 DC-DC Power Supply Assembly 6-26
- Testing Operation After Repairs 6-28**
  - Overview of the Diagnostic LEDs 6-28
  - To Perform the Power-Up Diagnostic Selftest 6-30
- Replaceable Parts 6-31**
  - Exchange Assemblies 6-31
  - Reference Designations 6-31
  - About the Replaceable Parts List 6-31
  - How To Order A Part 6-32
    - Parts Identification 6-32
  - Chassis Parts and Hardware 6-33
  - Replaceable Parts List 6-33
- Backdating 6-34**
  - To Connect DC Power 6-34
    - Power Requirements 6-34
    - Current Demands 6-34
    - Connecting DC Power If No Power Cables Exist 6-34
    - Connecting DC Power Using Existing Site Power Cables 6-36

## **A Performance Test Information**

- Appendix Contents A-2**

## **Index**

# Contents

## Documentation Map

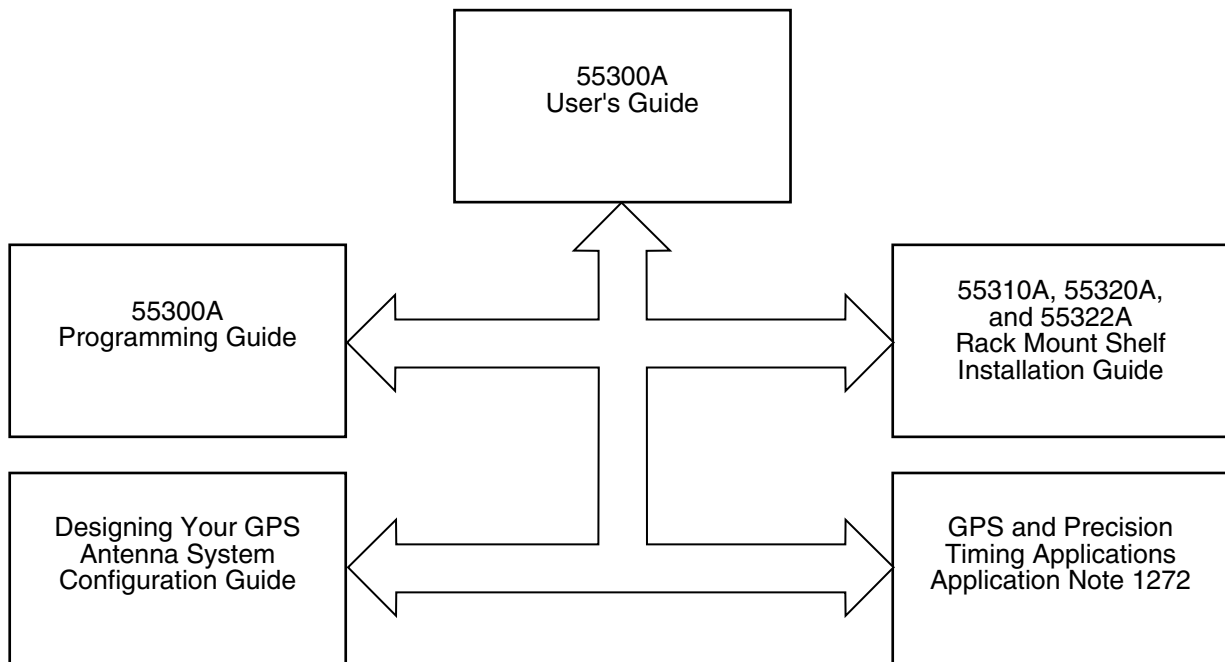

**55300A User's Guide**—provides information needed to install, use, and service the 55300A GPS Telecom Primary Reference Source.

**55300A Programming Guide**—provides TL1 command information needed to remotely operate and to program the 55300A GPS Telecom Primary Reference Source.

**55310A, 55320A, and 55322A Installation Guide**—provides information needed to install the rack mount shelves.

**Configuration Guide**—provides information needed to configure Symmetricom's Global Positioning System (GPS) timing receiver and antenna systems, using GPS associated accessories, which simplify installation.

**Application Note 1272**—provides information that describes how the structure, control, and operation of the NAVSTAR Global Positioning System makes for a source of precise time, time interval, and frequency.

55300A

**Documentation Map**

---

# In This Guide

This preface contains the following information:

- Guide Organization page xiii
- Description of the 55300A GPS Telecom Primary Reference Source page xiv
- Options page xviii
- Accessories Supplied and Available page xix
- Manuals page xxi

---

## Guide Organization

**Table of Contents** lists the beginning of each chapter in the guide, helping you locate information.

**In This Guide** (this preface) introduces you to the User's Guide, and provides general information on the 55300A GPS Telecom Primary Reference Source.

Chapter 1, "**Getting Started**," is a quick-start chapter that introduces you to the 55300A with a brief overview of the 55300A indicators and connectors. Installation and power-up instructions, and a section that provides sample commands to start operating the 55300A are provided to get you familiar and comfortable with operating it.

Chapter 2, "**Acceptance Test**," provides procedures that verify the 55300A operates properly and meets its electrical performance specifications. Electrical performance is tested against the specifications listed in Chapter 5, "Specifications," in this guide.

Chapter 3, "**Features and Functions**," provides information on 55300A features and functions, connecting to computers, and problem solving (that is, a section titled "In Case of a Problem").

Chapter 4, "**Using the Receiver Status Screen**," provides information on how to use the Receiver Status screen and the SatStat program. An illustrated foldout of the Receiver Status screen, which is a comprehensive summary of key operation conditions and settings, is provided at the end of this chapter.

Chapter 5, "**Specifications**," lists the 55300A specifications and characteristics.

Chapter 6, “**Maintenance**,” provides troubleshooting, exchange, and replaceable parts information.

Appendix A, “**Performance Test Information**,” provides a place to insert your factory-tested results of the MTIE, TDEV, and Holdover specifications. These specifications results are provided with your 55300A. A phase jitter graph is also provided.

## Index

---

# Description of the 55300A GPS Telecom Primary Reference Source

## Overview

The 55300A GPS Telecom Primary Reference Source provides highly accurate frequency outputs of 1544 kHz and 1544 kbps or 2048 kHz and 2048 kbps, and 10 MHz, which can be used as a synchronization source for all office levels in a telecommunication network.

## Operation

When locked to the GPS signal, the 55300A provides DS1<sup>1</sup> (1544 kHz and 1544 kbps) or 2048 kHz and 2048 kbps<sup>2</sup> signals with an accuracy of better than  $\pm 1 \times 10^{-12}$  using a 1-day average, and a 1 pulse per second (1PPS) signal with timing jitter of < 25 ns. When properly installed and calibrated, the 55300A can obtain time accuracy of 110 ns (95%) probability. These specifications are in the presence of SA (Selective Availability), and they hold for temperature changes of up to 12° C per hour anywhere in the 0° to 50° C operating temperature range.

If the GPS signal is interrupted, the 55300A enters an intelligent holdover mode that uses SmartClock™ technology. SmartClock technology takes over control of the quartz oscillator, which has been steered to the GPS reference during locked operation. SmartClock predicts the performance of the quartz oscillator based on the information gathered during the “learning period” (locked to GPS). Corrections are automatically issued over time, keeping the

---

<sup>1</sup> DS1 (Digital Signal Level 1) is a 1544 kbps standard interface that is known as the T1 frequency for US telecommunications.

<sup>2</sup> 2048 kbps and E1 are synonymous telecommunication signals. This is a standard interface signal for non-US telecommunications.

performance of the quartz oscillator as close as possible to the performance achieved while locked to the GPS reference signal. Holdover frequency is maintained to better than  $\pm 1 \times 10^{-10}$  per day (phase accumulation  $< 8.6 \mu\text{seconds}$  after 1 day). When the GPS reference signal is restored, the 55300A automatically switches back to its normal mode of operation.

### Control and Communications

The 1544 kbps or 2048 kbps **MONITOR** connector allows an operator to monitor the 1544 kbps or 2048 kbps output from the front panel, which is a protected output. The local interface (**PORT 1**) provides maintenance person access to status and control using the TL1 command set.

The 55300A has no front-panel display or keypad entry. Information is remotely entered into and retrieved from the 55300A using a terminal or computer connected to one of the serial interface ports (**REMOTE ACCESS PORT** and **PORT 1**), using TL1 commands. Time of day and status information can also be retrieved from the 55300A using a computer connected to the **TIME OF DAY** serial interface port, using SCPI (Standard Commands for Programming Instruments).

### Physical Description

The 55300A is a module that slides into either a 55310A GPS NEBS/EIA Rack Mount shelf configuration, or a 55320A GPS ETSI Rack Mount shelf configuration for unbalanced outputs (options 270, 271, and 272), or a 55322A GPS ETSI Rack Mount shelf configuration for balanced outputs (options 220, 221, and 222). The 55310A, 55320A, and 55322A usually have been mounted and pre-wired for the GPS antenna, alarms, power, and system control prior to installing the 55300A.

The controls, indicators, and input/output connectors on 55300A and its different rack mount shelves are described in the following subsections.

## ***Front Panel of 55300A Module***

### **Connectors and Controls**

- **PORT 1** (Local Interface)—RS-232, DE-9S (female) connector, DCE configuration serial interface, TL1 language.
- **MONITOR** (1544 kbps or 2048 kbps) protected output—is a standard miniature telecommunications phone jack.
- **ACO**—pushbutton alarm cutoff, silences audible external alarms
- **ACO Reset**—pushbutton alarm reset

### **Indicators**

The front panel of the 55300A module contains seven Light-Emitting-Diode (LED) indicators to indicate that:

- power has been applied (**Power**)
- the 55300A has tracked and locked on to one or more GPS satellites (**GPS Lock**)
- the GPS system is operating in holdover mode (**Holdover**)
- various levels (critical, major, minor) of error or invalid conditions due to system fault or reduced accuracy of the outputs exists (**Critical, Major, Minor**)
- alarm cutoff is active (**ACO Active**)

## ***Rear Panel of the 55310A Rack Mount Shelf***

- **GPS ANTENNA** input—N-type female connector
- Redundant **-48 VDC INPUT** jacks—for backup power should one dc power source fail.
- **DS1** (1544 kbps) outputs—wire-wrap connectors
- **1544 kHz** outputs—BNC connectors
- **10 MHz** output—BNC connector
- **1PPS** output—BNC connector
- **IRIG-B** (Time of Day) output—BNC connector
- **REMOTE ACCESS PORT** (Remote Interface)—RS-232, DB-25S pin (female) connector, DTE configuration serial interface at 9.6 kbps, TL1 language.
- **TIME OF DAY** (Time of Day/1 PPS)—RS-232, DE-9P (male) connector, SCPI command set and 1 PPS signal for network time protocol driver.



- **1PPS** rear-panel output—wire-wrap connectors
- **Local/Remote** rear-panel alarms—wire-wrap connectors for critical, major, and minor alarms.

***Top Front Panel of 55320A/55322A Rack Mount Shelf***

- **GPS ANTENNA** input—N-type female connector
- Redundant **~48 VDC INPUT** jacks—for backup power should one dc power source fail
- **2048 kbps** outputs—BNC connectors (55320A) or D connectors (55322A)
- **2048 kHz** Squelched or Continuous outputs—BNC connectors
- **10 MHz** output—BNC connector
- **1PPS** output—BNC connector
- **1PPS** negative and positive outputs (differential pair)—BNC connectors (55320A) or D connectors (55322A)
- **IRIG-B** (Time of Day) output—BNC connector
- **REMOTE ACCESS PORT** (Remote Interface)—RS-232, DB-25S pin (female) connector, DTE configuration serial interface at 9.6 kbps, TL1 language.
- **TIME OF DAY** (Time of Day/1 PPS)—RS-232, DE-9P (male) connector, SCPI command set and 1 PPS signal for network time protocol driver.
- **ALARMS** RS-232, DB-25P (male) connector—connections for critical, major, and minor alarms.

---

## Options

The 55300A is equipped to handle several telecommunications output options for 1544 kHz and 1544 kbps and 2048 kHz and 2048 kbps applications. Standard outputs are 1544 kHz (or 2048 kHz), 10 MHz, and 1 PPS.

Standard to all units are two ~48 Vdc power inputs and Time of Day (TOD) measurements. The TOD capabilities are available in two configurations, a 1 PPS via the RS-232 DE-9P DTE male connector, and a BNC connector for IRIG-B format applications.

When ordering your unit, you needed to select the appropriate telecommunications output option and rack mount shelf. The following subsections define the different telecommunications output option and rack mount shelf combinations.

### **Frequency Outputs (Selection Made When You Ordered the 55300A)**

#### ***NEBS (US) Version***

For US telecom outputs, order the combination of the *55310A GPS NEBS/EIA Rack Mount Shelf* and the *55300A GPS Telecom Primary Reference Source* with one of the following frequency options:

- Option 104      1544 kbps, DS1 D4  
(Super Frame)
- Option 105      1544 kbps, DS1 ESF  
(Extended Super Frame)

#### ***ETSI (International) Version (Balanced Outputs)***

For international balanced telecom outputs, order the combination of the *55322A GPS ETSI Rack Mount Shelf (with subminiature D, DE-9S connectors for 2048 kbps and 1 PPS)* and the *55300A GPS Telecom Primary Reference Source* with one of the following frequency options:

- Option 220      2048 kbps, 120Ω Balanced, CCS  
(Common Channel Signaling)
- Option 221      2048 kbps, 120Ω Balanced, CAS  
(Channel Associated Signaling)
- Option 222      2048 kbps, 120Ω Balanced, CCS-CRC4  
(Cyclic Redundancy Check)

### ***ETSI (International) Version (Unbalanced Outputs)***

For international unbalanced telecom outputs, order the combination of the *55320A GPS ETSI Rack Mount Shelf (with BNC connectors for 2048 kbps and 1 PPS)* and the *55300A GPS Telecom Primary Reference Source* with one of the following frequency options:

- Option 270      2048 kbps, 75Ω Unbalanced, CCS  
(Common Channel Signaling)
- Option 271      2048 kbps, 75Ω Unbalanced, CAS  
(Channel Associated Signaling)
- Option 272      2048 kbps, 75Ω Unbalanced, CCS-CRC4  
(Cyclic Redundancy Check)

---

## **Accessories Supplied and Available**

### **Accessories Supplied**

SatStat Program (59551-13401)

### **Accessories Available**

#### ***Telecom Accessories***

HP Telecom Mask Test Disk (55300-13401) (or equivalent)

#### ***GPS Accessories***

For more details on available GPS accessories refer to the *Designing Your GPS Antenna System Configuration Guide* (HP P/N 5964-9068E). Refer to the subsections titled “Recommended Antenna Cable Assemblies” and “Antenna Cable Length Delay” in Chapter 3 of this guide for more cable information.

- 58504A GPS Antenna Assembly
- 58510A GPS Antenna Environmental Cover and Ground Plane (optional use with the 58504A GPS Antenna Assembly)<sup>3</sup>
- 58513A GPS Antenna Assembly<sup>4</sup>
- 58505B Lightning Arrester

---

<sup>3</sup> The 58510A Environmental Cover and Ground Plane provides additional protection for the antenna and can help reduce multipath effects in an installation subject to signal reflections.

<sup>4</sup> The 58513A is a completely assembled unit, which includes the 58504A Antenna, a 4-foot cable, the 58510A environmental cover and ground plane, and a 1-foot stainless steel mounting mast.

- 58509A Antenna Line Amplifier (recommended for distances greater than 175ft./53.3 meters for RG-213 cable; 200 ft/61 meters for LMR cable)
- 58518A RG-213 Antenna Cable Assembly (3.3 to 164.0 ft, or 1 to 50 meters)—TNC-to-N connectors
- 58519A RG-213 Interconnect Cable Assembly (3.3 to 164.0 ft, or 1 to 50 meters)—N-to-N connectors
- 58520A LMR 400<sup>5</sup> Antenna Cable Assembly (3.3 to 360.8 ft, or 1 to 110 meters)—TNC-to-N connectors
- 58521A LMR 400<sup>5</sup> Interconnect Cable Assembly (3.3 to 360.8 ft, or 1 to 110 meters)—N-to-N connectors
- 58518AA<sup>6</sup> RG-213 Antenna Cable Assembly (3.3 to 164.0 ft, or 1 to 50 meters)—without connectors attached
- 58519AA<sup>6</sup> RG-213 Interconnect Cable Assembly (3.3 to 164.0 ft, or 1 to 50 meters)—without connectors attached
- 58520AA<sup>6</sup> LMR 400 Antenna Cable Assembly (3.3 to 360.8 ft, or 1 to 110 meters)—without connectors attached
- 58521AA<sup>6</sup> LMR 400 Interconnect Cable Assembly (3.3 to 360.8 ft, or 1 to 110 meters)—without connectors attached

### ***Serial Interface Accessories***

- HP 24542G (or equivalent) DTE-to-DTE 25-Pin (m) to 9-pin (f) RS-232 Interface Cable
- HP 24542U (or equivalent) DTE-to-DTE 9-Pin (f) to 9-pin (f) RS-232 Interface Cable
- HP F1021B (or equivalent) Palmtop Connectivity Pack, for Palmtop to DOS-Compatible PCs—contains proper 9-pin (f) to miniature 10-pin (f) RS-232 interface cable for the HP 200LX Palmtop computer
- HP 40242M (or equivalent) DTE-to-DCE 25-Pin (m-to-f) RS-232 Interface Cable
- HP F1047-80002 (or equivalent) DTE-to-DTE 9-pin (f-to-f) RS-232 Interface Cable
- HP 5181-6639 (or equivalent) DCE-to-DTE 9-pin to 9-pin (m-to-m) Adapter (Black)

---

<sup>5</sup> LMR 400 cables are low-loss, less flexible than RG-213, but very good coaxial cables.

<sup>6</sup> These cables do not have the connectors attached. A connector kit is supplied.

## Manuals

### Supplied Manuals

The following guides that document the 55300A are shipped with the product.

- 55300A User's Guide (this guide), P/N 097-55300-01
- 55300A Programming Guide, P/N 097-55300-02
- 55310A, 55320A, and 55322A Installation Guide, P/N 097-55310-01 (supplied with the rack mount shelves)

### Available Documents

- *Designing Your GPS Antenna System*  
Configuration Guide, HP P/N 5964-9068E
- *GPS and Precision Timing Applications*  
Application Note 1272, HP P/N 5963-6852E



---

1

---

Getting Started

---

## 55300A Front Panel at a Glance

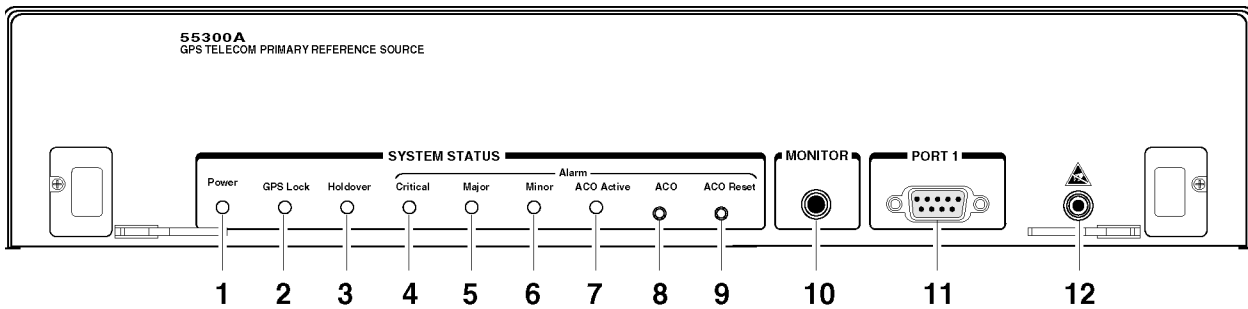



## Chapter 1 Getting Started

### 55300A Front Panel at a Glance

- 1 When the **Power** indicator is illuminated, it indicates that the proper input power is supplied to the unit.
- 2 When the **GPS Lock** indicator is illuminated, it indicates that the unit is tracking satellites and has phase-locked its internal reference to the reference provided by GPS.
- 3 When the **Holdover** indicator is illuminated, it indicates that the unit isn't phase-locking its internal reference to the reference provided by the GPS. Typically, this would happen due to loss of satellite tracking because of a problem with the antenna connection or location. The internal reference oscillator will determine the accuracy of the 1 PPS signal during the holdover period. (See specification for Accuracy in Holdover in Chapter 5, "Specifications," in this guide.)
- 4 When the **Critical** alarm indicator is illuminated, it indicates a hardware condition or failure needs attention.
- 5 When the **Major** alarm indicator is illuminated, it indicates that there is a problem that can potentially affect the outputs of the unit; thus, the problem should be taken care of soon (e.g., the unit is operating in the holdover longer than the user-specified duration, which may cause the unit to output imprecise timing signals).
- 6 When the **Minor** alarm indicator is illuminated, it typically indicates that the unit has detected a momentary, abnormal internal condition, but the condition doesn't bother the operation of the unit.
- 7 When the **ACO Active** indicator is illuminated, it indicates that the local alarm cutoff is active.
- 8 **ACO** is a non-locking pushbutton switch that, when pushed, *silences* the audible, local external alarms without turning off the alarm LED indicator.
- 9 **ACO Reset** is a non-locking pushbutton switch that, when pushed, *resets* ACO. The **ACO Active** LED indicator is turned off if the alarm LED indicators are turned off.
- 10 **MONITOR** (1544 kbps or 2048 kbps) output is a standard miniature telecommunication phone jack. This telecom output is a protected test output similar to the rear-panel **DS1** wire-wrap pin outputs of the 55310A or the top front panel **2048 kbps** output of the 55320A and 55322A. The only difference is the **MONITOR** output signal level is 18 dB less.
- 11 **PORT 1** RS-232, DE-9S (female), DCE configuration serial interface port for local monitoring and retrieving data stored in the unit's memory data. The communication language is TL1.
- 12 Banana jack for grounding an Electrostatic Discharge (ESD) wrist strap.

---

## 55300A/55310A Rear Panel at a Glance

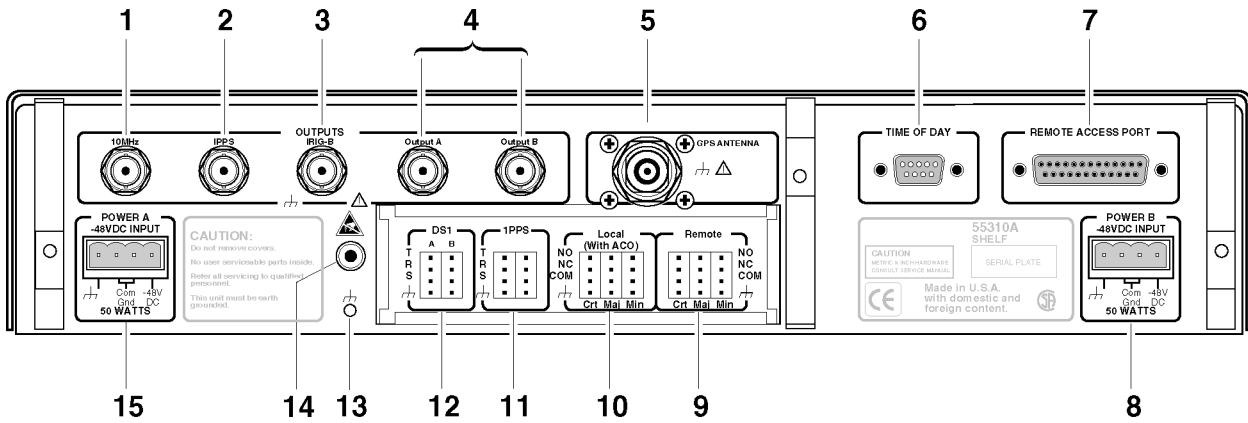

Chapter 1 Getting Started  
55300A/55310A Rear Panel at a Glance

- 1 **10MHZ** BNC connector outputs a 10 MHz signal for user-specific applications.
- 2 **1 PPS** BNC connector outputs a continuous 1 Pulse Per Second signal. This 1 PPS is a 50Ω TTL level signal.
- 3 **IRIG-B** BNC connector outputs formatted time-code signals, after the unit locks to GPS. (This signal is used for general purpose time distribution and magnetic tape annotation applications requiring the time of year.)
- 4 **Output A** and **B** telecom outputs that meet all of the specifications (i.e., impedance, frequencies, etc.) required for a T1 or US (1544 kHz) telecommunications signal. These are identical 1544 kHz output signals, except that the squelched signal (**Output B**) is present only after the unit is locked to GPS, whereas the continuous signal (**Output A**) is always present.
- 5 N-type (female) **GPS ANTENNA** input connector for connecting the GPS antenna to the unit.
- 6 **TIME OF DAY** RS-232 serial interface port's communication language is SCPI. The connector is a DTE configuration DE-9P (male). Time of Day data and a 1 PPS (accurate to UTC) signal are provided on this port for the network time protocol driver.
- 7 **REMOTE ACCESS PORT** RS-232, DB-25S (female), DTE configuration serial interface port for remote control, monitoring, and retrieving of the unit's memory data. The communication language is TL1.
- 8 **POWER B –48VDC INPUT** for connecting dc power to the unit; part of the two redundant dc power inputs.
- 9 **Remote** wire-wrap connectors provide three independent alarm contacts or relays for the critical, major, and minor alarms.
- 10 **Local (with ACO)** wire-wrap connectors provide three independent alarm contacts or relays for the critical, major, and minor alarms. These local external audible alarms can be cutoff or can be caused to not operate.
- 11 **1 PPS** wire-wrap connectors provide two sets of outputs from one 1 PPS signal. This 1 PPS signal is a RS-422 differential pair signal. The two sets of wire-wrap outputs allow operators the flexibility of bridging to another line or changing the distribution system without downtime. Each connector has a T (tip), R (ring), S (sleeve), and chassis ground (optional use) connection. The T, R, and S wire-wrap pins allow shielded, twisted pair connections to a standard three-circuit phone plug. The 1 PPS signal is across the T (+) and R (return) pins.
- 12 **DS1** (Digital Signal Level 1—1544 kbps) wire-wrap connector outputs is a T1 or US telecommunications signal. The two sets of wire-wrap outputs from one DS1 output allow operators the flexibility of bridging to another line or changing the distribution system without downtime. Each connector has a T (tip), R (ring), S (sleeve), and chassis ground (optional use) connection. The T, R, and S wire-wrap pins allow shielded, twisted pair connections to a standard three-circuit phone plug. The 1544 kbps signal is across the T (+) and R (return) pins.
- 13 Frame-ground stud for chassis-ground connection.
- 14 Banana jack for grounding an Electrostatic Discharge (ESD) wrist strap.
- 15 **POWER A –48VDC INPUT** for connecting dc power to the unit; part of the two redundant dc power inputs.

# 55300A/55320A and 55300A/55322A Top Front Panels at a Glance

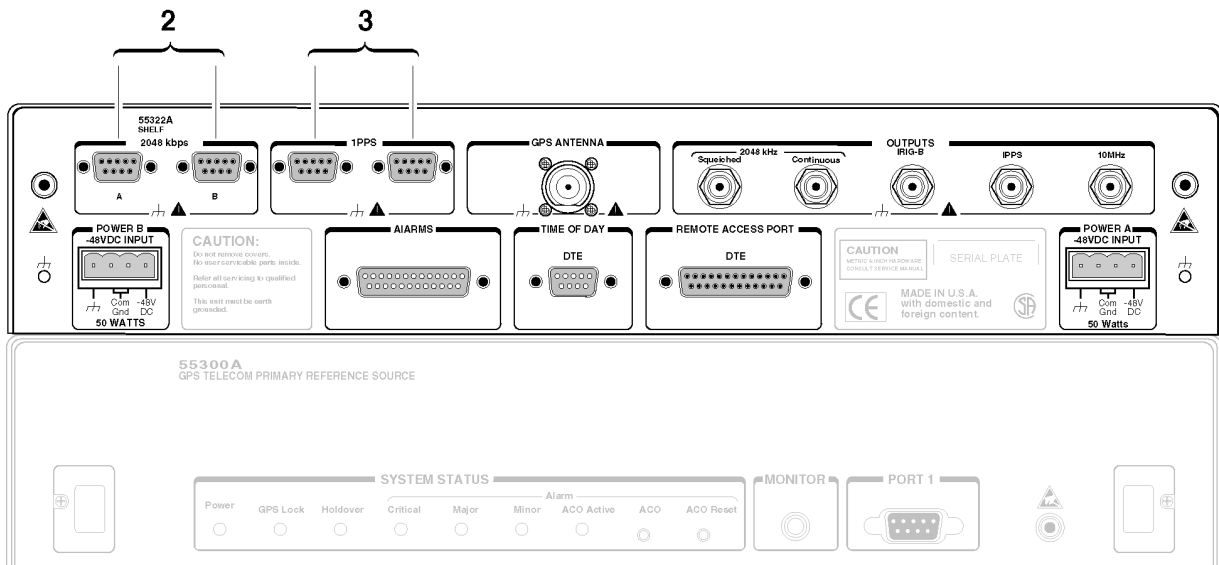
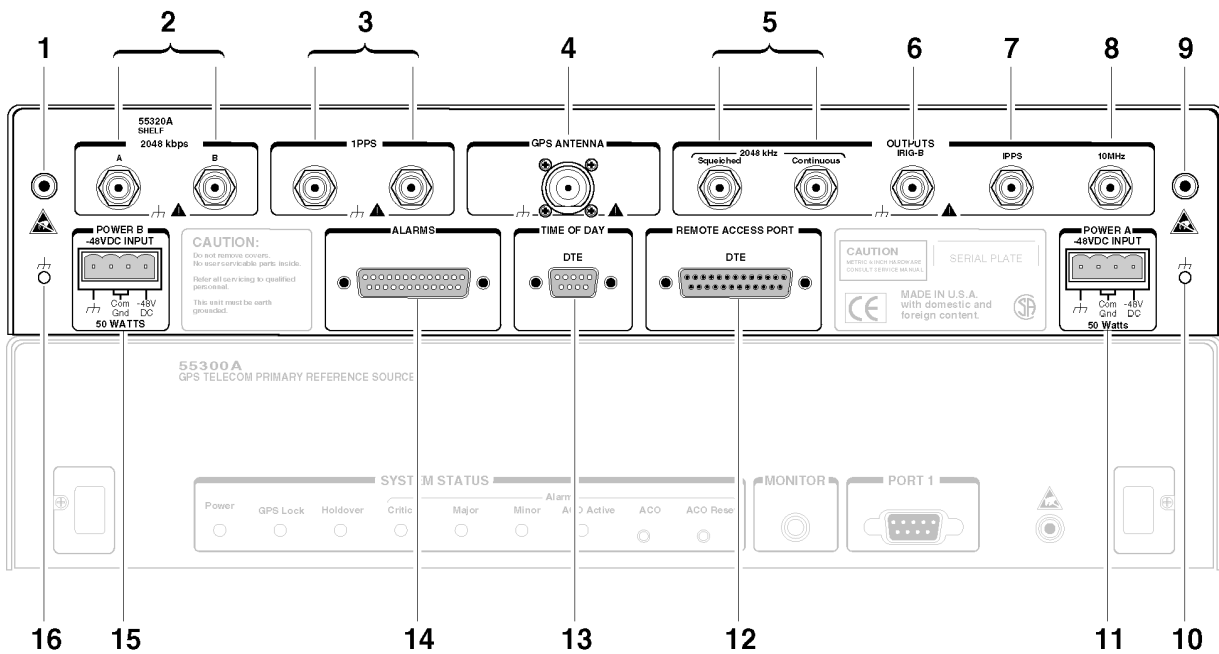

- 1** Banana jack for grounding an Electrostatic Discharge (ESD) wrist strap.
- 2** **2048 kbps** telecom A and B outputs meet the specifications required for a non-US (2048 kbps) telecommunications signal. These formatted outputs are squelched (not present) until the unit is locked to GPS. These connectors are BNCs on the 55320A, or DE-9S subminiature D connectors on the 55322A.
- 3** **1 PPS** RS-422 differential pair output signals. One signal is a positive 1 PPS signal, and the other is a negative 1 PPS signal. The signal from the left connector (viewing from front of the 55300A) is the positive 1 PPS, and the other is the negative 1 PPS. These connectors are BNCs on the 55320A, or DE-9S subminiature D connectors on the 55322A.
- 4** N-type (female) **GPS ANTENNA** input connector for connecting the GPS antenna to the unit.
- 5** Two identical BNC **2048 kHz** output signals, except that the Squelched signal is present only after the unit is locked to GPS, whereas the Continuous is always present.
- 6** **IRIG-B** BNC outputs formatted time-code signals, after the unit is locked to GPS. (This signal is used for general purpose time distribution and magnetic tape annotation applications requiring the time of year.)
- 7** **1 PPS** BNC connector outputs a continuous 1 Pulse Per Second signal. This 1 PPS is a 50 $\Omega$  TTL level signal.
- 8** **10MHZ** BNC outputs a 10 MHz signal for user-specific applications.
- 9** Banana jack for grounding an Electrostatic Discharge (ESD) wrist strap.
- 10** Frame-ground stud for chassis-ground connection.
- 11** **POWER A –48VDC INPUT** for connecting dc dc power to unit.
- 12** **REMOTE ACCESS PORT** RS-232, DB-25S (female), DTE configuration serial interface port for remote control, monitoring, and retrieving of the unit's memory data. The communication language is TL1.
- 13** **TIME OF DAY** serial interface port's communication language is SCPI. The connector is a DTE configuration DE-9P (male). Time of Day data and a 1 PPS (accurate to UTC) signal are provided on this port for the network time protocol driver.
- 14** **ALARMS** DB-25 P (male) connector provides three independent alarm relays for the critical, major, and minor alarms for all office alarms (both visual and audible). These local external audible alarms can be cutoff or can be caused to not operate.
- 15** **POWER B –48VDC INPUT** for connecting backup or redundant dc power to the unit.
- 16** Frame-ground stud for chassis-ground connection.

---

## 55310A, 55320A, 55322A Rack Mount Shelves at a Glance

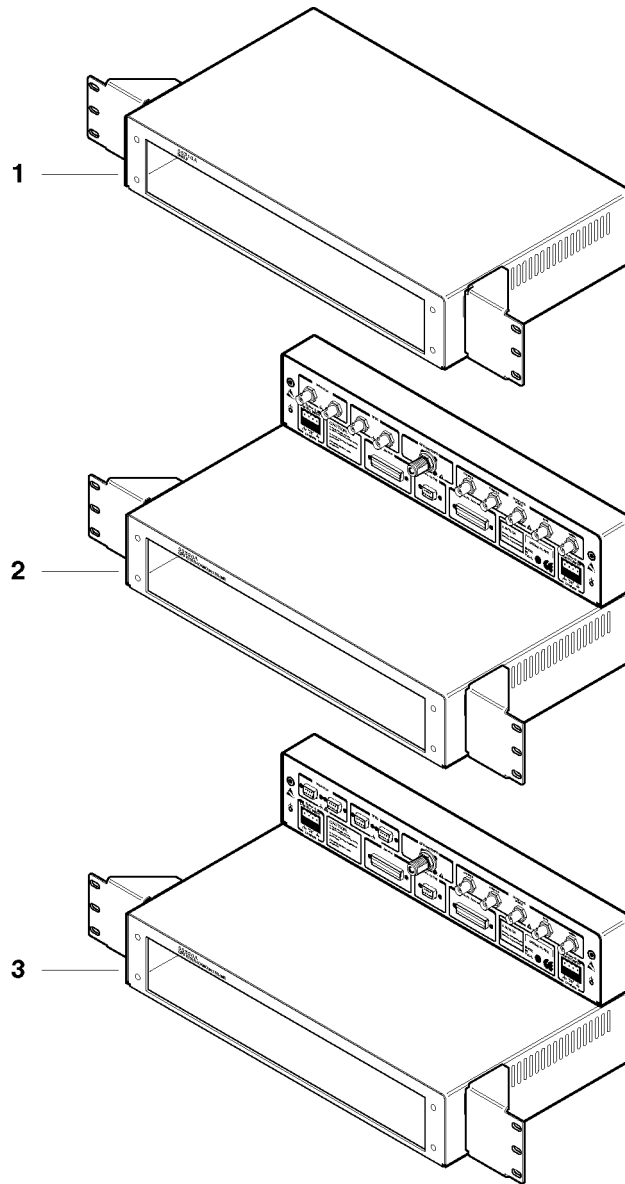

**1** 55310A GPS NEBS/EIA Rack Mount shelf

**2** 55320A GPS ETSI Rack Mount shelf

**3** 55322A GPS ETSI Rack Mount shelf

---

## Preparing the 55300A for Use

### To Install the 55300A into a Rack Mount Shelf

There are three types of rack mount shelves: 55310A GPS NEBS/EIA, 55320A GPS ETSI, and 55322A GPS ETSI (see page 1-8).

If the 55300A is not already installed in the rack mount shelf, install it as shown in Figure 1-1.

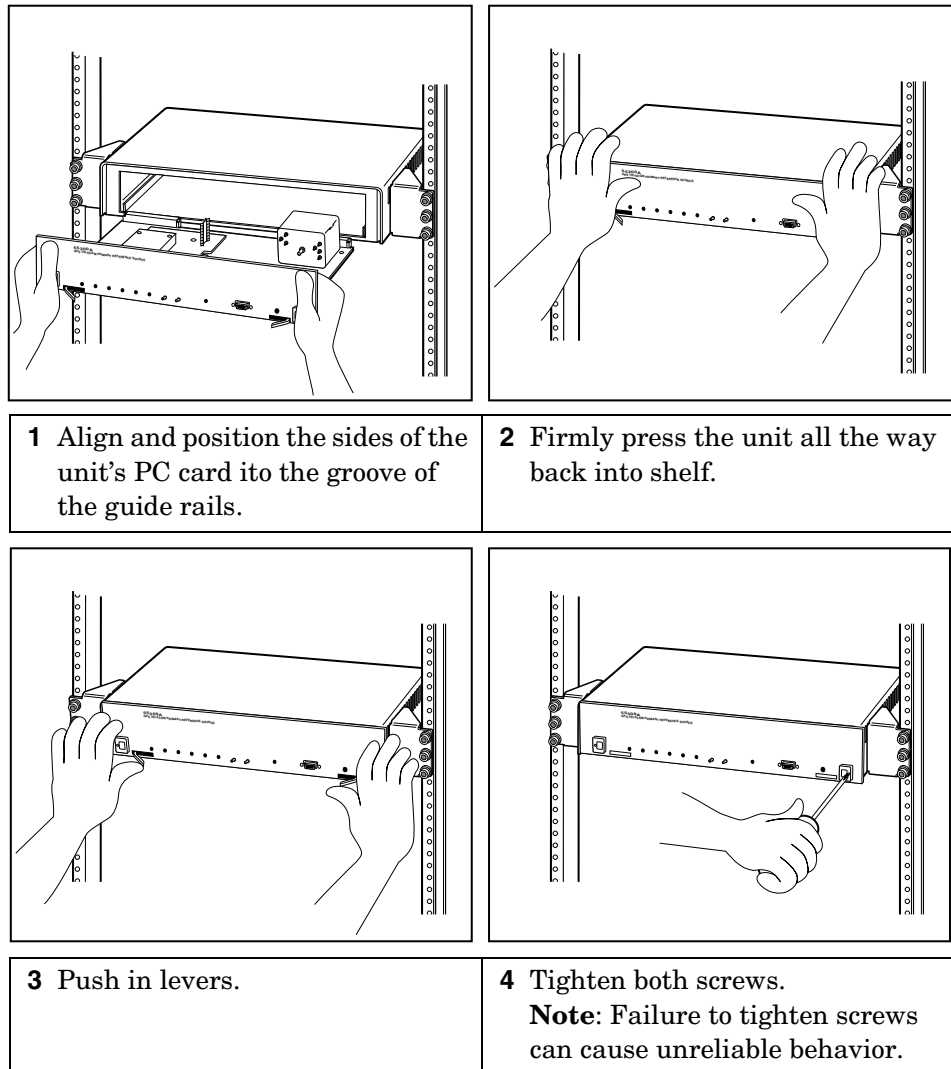

**Figure 1-1. Installing the 55300A into a Rack Mount Shelf (NEBS/EIA Rack Mount Shelf is shown)**

## To Assemble and Install the Antenna System

**CABLE CONSIDERATIONS.** *When using the antenna cables with the 55300A, you should observe certain precautions. Consult your local electrical and building ordinance codes on how to install RG-213 cables (58518A/519A) or LMR 400 cables (58520A/521A). Certain codes might require you to put the cables inside a conduit, or to use cables made with a non-toxic fire retardant insulation.*

To assist you with installing your GPS antenna system, refer to the following documents:

- *Designing Your GPS Antenna System Configuration Guide* (HP P/N 5964-9068E), which discusses the components of a GPS timing receiver system and how to custom design the configuration of your antenna system.
- Information Notes that provide installation procedures for the applicable GPS antenna and accessories that you purchase.
- The subsection titled “GPS ANTENNA Input” in Chapter 3, “Features and Functions” of this guide.

## To Connect DC Power

### *Power Requirements*

Due to the high reliability requirements for telecom equipment, it is recommended that you take advantage of the dual-redundant power supply capability of the 55300A by providing two separate power connections to the rack mount shelf from separate power sources.

### *Current Demands*

The 55300A maximum current usage is 1 Amp at –48 Vdc. From a cold start, the current is about 0.75 amps. After the cold start, the current usage drops to about 0.33 amps.



### ***Connecting DC Power If No Power Cables Exist***

---

**NOTE**

Depending on when your 55310A/55320A Rack Mount Shelf was manufactured, the two supplied dc power plugs could be the four-pin, dc power connector plugs or the three-pin, dc power connector plugs. Older versions of the 55300A/55310A/55320A were supplied with the four-pin dc power plugs. Refer to the section titled “Backdating” in Chapter 6, “Maintenance,” of this guide.

- 1 Note that you will have to assemble your own dc power cables using 20 AWG (0.08 inch or 2 mm diameter) connecting wires and the supplied, three-pin, dc power connector plugs as shown in Figure 1-2A.

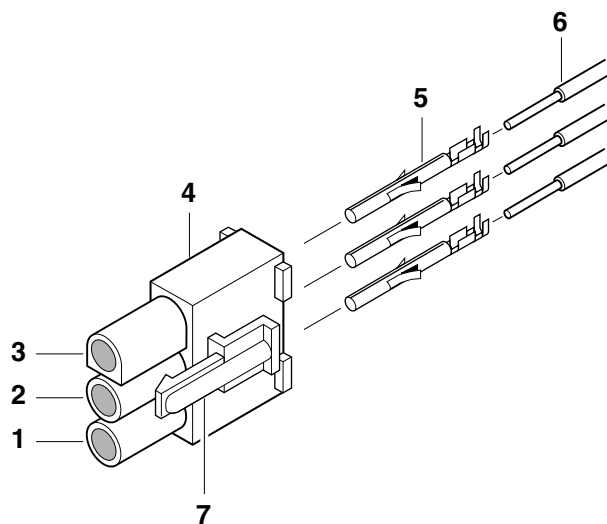

- |                            |                     |
|----------------------------|---------------------|
| 1 -48 Vdc battery supply   | 5 Terminal pins     |
| 2 Com Gnd (battery return) | 6 Wires             |
| 3 Ground (frame ground)    | 7 Locking mechanism |
| 4 Power connector          |                     |

**Figure 1-2A. Three-Pin DC Connector Pin Assignments**

- 2 Strip 5 mm (3/16 in) of insulation from one set of the power supply wires.
- 3 Crimp the terminal pins to the wires according to standard procedures. Figure 1-2B shows a crimped terminal pin. The terminal pins can accept a wire size up to 1.2 mm (0.05 in). If possible, use a crimping tool such as Molex® Hand Crimping Tool 11-01-0084.

## Preparing the 55300A for Use

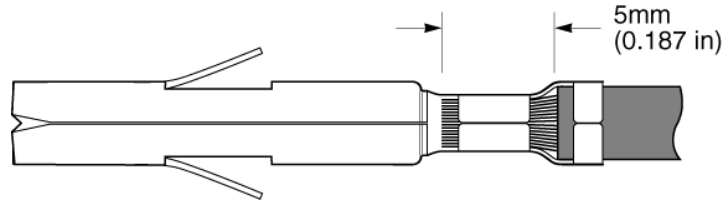

**Figure 1-2B. View of Crimped Terminal Pin**

- 4 Position the power connector so that it matches the drawing—locking mechanism (7) should face you; see Figure 1-2A. Take the **Ground** (frame ground) wire and grasp the wire insulation behind the terminal pin. Push this wire into plug position **3** of the power connector until the terminal pin snaps into place.
- 5 Using the same procedure in step 4, push the **Com Gnd** (battery return) wire into connector position **2** and the **-48 Vdc** wire into connector position **1**.

---

**CAUTION**

---

**SYSTEM GROUNDING.** Common ground on the rack mount shelf (55310A, 55320A, or 55322A) for each -48 Vdc supply is the battery return. The frame ground, or chassis ground, must be separate from the common ground.

A frame ground can be connected in one of three ways:

- As part of the -48 Vdc three-pin connector plug.
- Through a single-wire connection to the ground stud on the rear panel (55310A) or top front panel (55320A/55322A). (Use a spade lug.)
- Through the rack mount brackets and the 55300A/55310A (or 55300A/55320A/55322A) when the rack itself is properly grounded.

---

**CAUTION**

---

To prevent battery return-to-frame ground faults, DO NOT connect battery return on the 55310A/55320A/55322A rack mount shelf to the frame ground.

- 6 Observing the correct polarity, attach the other ends of the wires to a proper dc power source to operate the 55300A.
- 7 Observing the correct polarity, insert the plug into the rear-panel **POWER A -48 VDC INPUT** jack of 55310A, 55320A, or 55322A rack mount shelf.

**Preparing the 55300A for Use**

- 8 Repeat steps 2 through 7 for rear-panel **POWER B –48 VDC INPUT** jack of 55310A, 55320A, or 55322A rack mount shelf for “alternate” dc power.

Refer to the subsection titled “POWER A and B –48 VDC Inputs” in Chapter 3, “Features and Functions,” in this guide for more information on the dc power inputs.

***Connecting DC Power Using Existing Site Power Cables***

- 1 Using the multimeter, verify that there are no multiple battery grounds, or any shorts at the power source end of the wires.
- 2 From the rear of the plug (see Figure 1-2A), connect the supply-side wire of the external power supply or battery to position **1** of the plug. Connect the external battery’s return (ground) wire to position **2**, and the chassis ground wire, if present, to position **3** of the plug.
- 3 Using a multimeter, verify a reading between –45 to –60 Vdc across position **1** of the dc connector and the dc return position **2**.
- 4 Observing the correct polarity, insert the plug into the rear-panel **POWER A –48 VDC INPUT** jack of 55310A, 55320A, or 55322A rack mount shelf.
- 5 Repeat steps 1 through 4 for the rear-panel **POWER B –48 VDC INPUT** jack of the rack mount shelf for redundant or “alternate” dc power.

Refer to the subsection titled “POWER A and B –48 VDC Inputs” in Chapter 3, “Features and Functions,” in this guide for more information on the dc power inputs.

## Connecting the 55300A to a Terminal or Computer

---

**NOTE**

Although connecting the 55300A to a terminal or computer isn't necessary for it to attain GPS lock, the terminal is needed for you to observe the progress of the 55300A or to configure alarms.

---

- 1 *If you are going to communicate with the 55300A using TL1 commands, connect the 55300A to a terminal via the rear-panel **REMOTE ACCESS PORT** RS-232 port using an HP 24542G (or equivalent) (25-pin male to 9-pin female) interface cable (or whichever cable is appropriate for your terminal) as shown in Figure 1-3A.*

OR

*If you are going to communicate with the 55300A from the front-panel **PORT 1** port using TL1 commands, connect the 55300A to a terminal or laptop using an HP F1047-80002 (or equivalent) (9-pin female to 9-pin female) interface cable and HP 5181-6639 (or equivalent) Adapter as shown Figure 1-3B.*

OR

*If you are going to communicate with the 55300A using SCPI commands, connect the 55300A to a PC or laptop via the rear-panel **TIME OF DAY** RS-232 port using an HP 24542U (or equivalent) (9-pin female to 9-pin female) or HP F1047-80002 (or equivalent) interface cable (or whichever cable is appropriate for your PC or laptop) as shown in Figure 1-3C.*

OR

*If you are going to use an HP 200LX (or equivalent) palmtop computer to communicate with the 55300A using SCPI commands, connect the 55300A to the palmtop via the rear-panel **TIME OF DAY** RS-232 port using the F1015-80002 cable as shown in Figure 1-3D.*

Connecting the 55300A to a Terminal or Computer

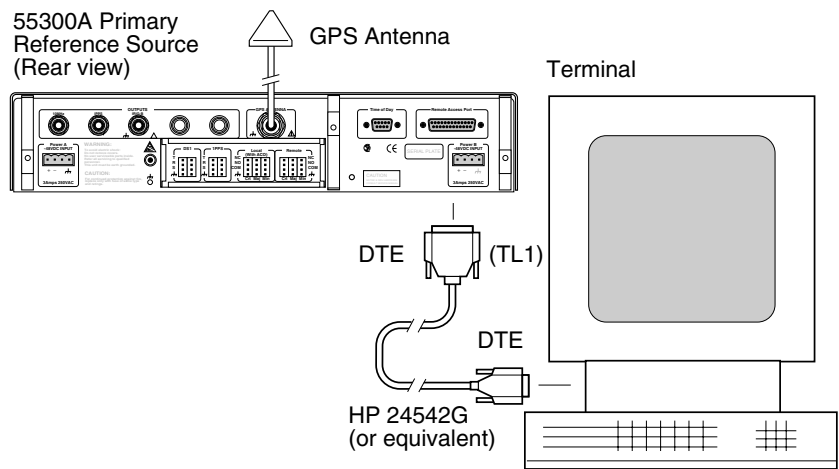

Figure 1-3A. Connecting the 55300A to a Terminal Via REMOTE ACCESS PORT to Use TL1 Commands for Communication (55300A/55310A shown)

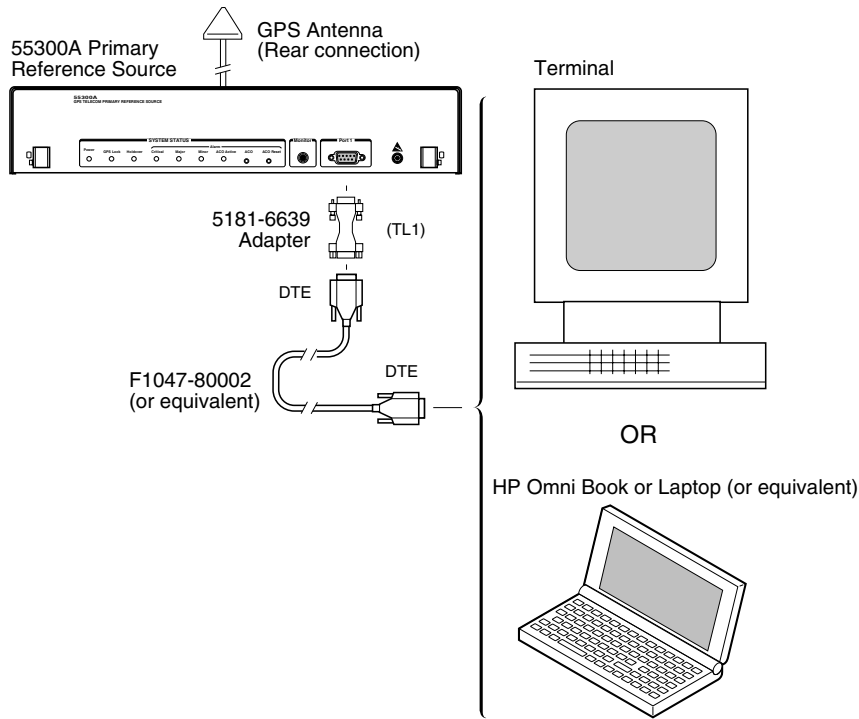

Figure 1-3B. Connecting the 55300A to a Terminal or Laptop Via PORT 1 to Use TL1 Commands for Communication (55300A/55310A shown)

Connecting the 55300A to a Terminal or Computer

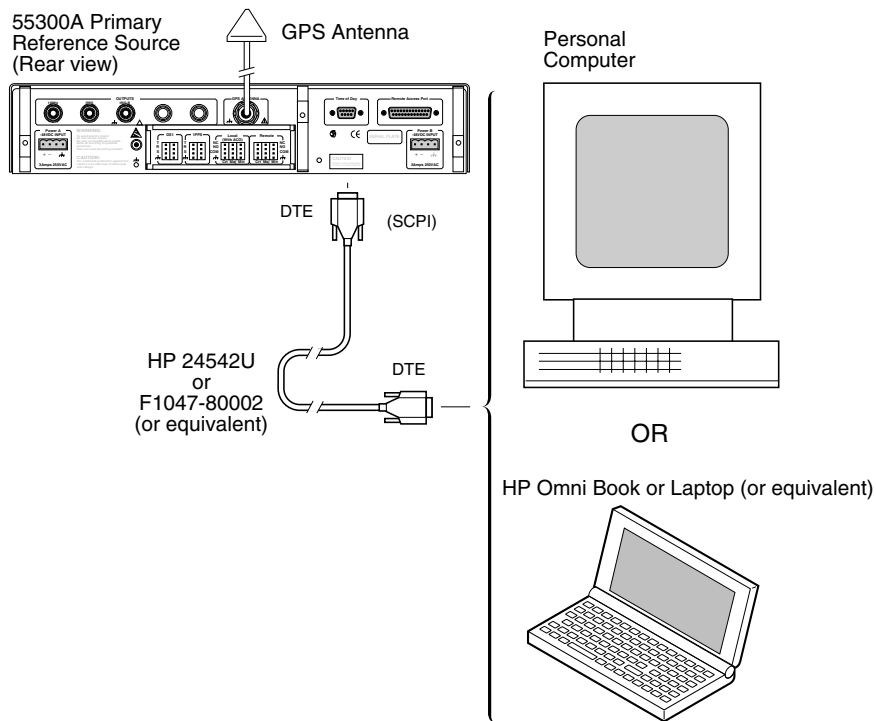

Figure 1-3C. Connecting the 55300A to a PC or Laptop to Use SCPI Commands for Communication (55300A/55310A shown)

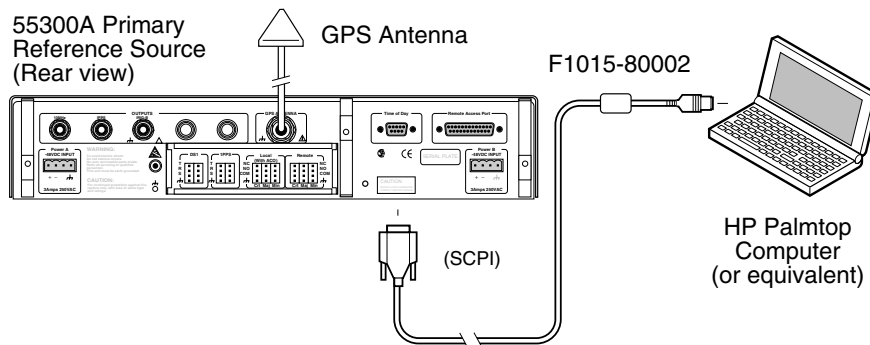

Figure 1-3D. Connecting the 55300A to a Palmtop to Use SCPI Commands for Communication (55300A/55310A shown)

## Connecting the 55300A to a Terminal or Computer

- 2 Turn the terminal or computer on.

*If you are using a personal computer (PC), you will need to run a terminal emulation or telecommunication program on your PC in order to communicate via the RS-232 serial port. Most PCs contain a terminal emulation program, especially PCs equipped with Windows. If your PC does not contain a telecommunication program, purchase one of the following programs: PROCOMM PLUS (DATASTORM Technologies, Inc.®), PROCOMM PLUS for Windows, Cross Talk (Hayes®), or any other terminal emulation program.*

- 3 *If you are using a Windows-based PC, perform the procedure in the subsection titled “To Configure Terminal Communications for Windows-based PC” on page 1-17.*

*If you are using a DOS-based PC (no Windows application), perform the procedure in the subsection titled “To Configure Terminal Communications for DOS-based Only PC (No Windows)” on page 1-18.*

*If you are using an HP 200LX (or equivalent) Palmtop computer, perform the procedure in the subsection titled “To Configure Terminal Communications for HP 200LX (or Equivalent) Palmtop” on page 1-19.*

### To Configure Terminal Communications for Windows-based PC

- 1 Select or double click on the Terminal icon (a picture of a PC with a telephone in front of it) in the Accessories window.
- 2 Select **Settings**, then choose **Communications**.

A dialog box is displayed that allows you to configure your PC.

- 3 Set the RS-232 port of your PC to match the following default values:

Pace:	NONE
Baud Rate:	9600
Parity:	NONE
Data Bits:	8
Stops Bits:	1

---

**NOTE**

The RS-232 port configurations of the 55300A and the PC must be the same for communications between the two. Thus, for the power-up procedure starting on page 1-20, set your PC to match the default values listed above if this 55300A is being powered up for the first time from the factory.

If the default values have been changed, as would be indicated by an error generation (**E-xxx**) or no **scpi>** prompt displayed after power-up procedure, then refer to the subsection titled “If Changes Have Already Been Made to the Serial Port Settings” in Chapter 3 of this guide for more information.

- 
- 4 In the Communications dialog box, be sure to select the appropriate port or connector (COM1, for example).
  - 5 Next, perform the power-up procedure described in the section titled “Powering Up the 55300A” on page 1-20.

**To Configure Terminal Communications for  
DOS-based Only PC (No Windows)**

- 1 Make sure you have a DOS telecommunication program such as PROCOMM PLUS and refer to a DOS reference guide for the proper command to send. *Hint:* send MODE COM2:9600, N,8,1 or MODE COM2:BAUD=9600, PARITY=NONE, DATA=8,STOP=1.
- 2 Next, perform the power-up procedure described in the section titled “Powering Up the 55300A” on page 1-20.



## To Configure Terminal Communications for HP 200LX (or Equivalent) Palmtop

---

**NOTE**

---

Follow the instructions on Datacomm in the HP 200LX User's Guide for details.

- 1 To start the Datacomm, press the **& ...** key, then the **C** key.
- 2 Set the Datacomm port of your Palmtop to match the following default values:

Pace: NONE

Baud Rate: 9600

Parity: NONE

Data Bits: 8

Stops Bits: 1

- 3 Next, perform the power-up procedure described in the following section.

## Powering Up the 55300A

### Overview of the Power-Up Procedure (What to Expect)

When you power up the 55300A for the first time, you should expect it to run through the following sequence:

- performs internal diagnostic check, and all front-panel indicators flash,
- all front-panel indicators turn off except the **Power** indicator.
- after about 5 minutes, the 55300A may enter Major alarm condition as indicated by illumination of the front-panel **Major** indicator and activation of the Major alarm relay.
- upon locking, the Major alarm condition is cleared,
- computes the 55300A's position, and
- while position is being refined, phase-locking of the internal reference to GPS is also occurring. When phase-lock is attained, **Major** indicator is turned off, and the **GPS lock** indicator lights.

Elapsed time for each step will vary, depending largely on how many satellites your antenna is able to “see” when you power up. If many satellites are visible when you power up, the 55300A will typically take from 8 to 25 minutes to calculate its position from the constellation of satellites overhead. The derived position will be improved over a period of time by further averaging. When the **GPS Lock** indicator lights, the functionality of the 55300A is available.

### To Power Up the 55300A

- 1 Connect the antenna system to the **GPS ANTENNA** Type-N connector of the rack mount shelf as described in the instructions given in the subsection titled “To Assemble and Install the Antenna System” on page 1-10 of this chapter.

---

**NOTE**

*Do not install the 55300A unless a fully operational antenna system is connected to the rear-panel GPS ANTENNA input connector. Power applied with no antenna input or a non-functioning antenna will initiate an extended search process that may increase time to reach GPS lock. You can halt the extended search by disconnecting and reconnecting (cycling) both of the external -48 V supplies of the 55310A/55320A/55322A (you may need to leave power off for greater than five seconds).*

---

**Powering Up the 55300A**

- 2 Apply the proper power source to the rear-panel **POWER A –48VDC INPUT** jack and the alternate **POWER B –48VDC INPUT** jack of the 55310A, 55320A, or 55322A rack mount shelf. (See the subsection titled “To Connect DC Power” on page 1-10)

The following sequence of events occurs after power is applied to the 55300A.

- a. Only the front-panel **Power** indicator lights.
- b. After a moment, the 55300A runs through its self-test diagnostics as indicated by the flashing front-panel indicators.
- c. After the self test is completed, just the **Power** indicator remains illuminated.

At this point, you can observe the GPS acquisition by using TL1 or SCPI commands.

If you are using TL1 commands to communicate with the 55300A, then perform procedure in the subsection titled “Using TL1 Commands to Obtain 55300A GPS Status” on page 1-22.

If you are using SCPI commands to communicate with the 55300A, then perform the procedure in the subsection titled “Using SCPI Commands to Obtain 55300A GPS Status” on page 1-23.

- d. After about 5 minutes, the 55300A may enter Major alarm condition as indicated by illumination of the front-panel **Major** indicator and activation of the Major alarm relay.
- e. The 55300A begins to search the sky for all available satellites.
- f. When four or more satellites are tracked as will be indicated in the status screen, automatic position computation is initiated.
- g. Finally, the 55300A goes into stable operation (which requires one satellite to maintain lock), the **GPS Lock** indicator lights and the **Major** indicator turns off, indicating the 55300A has phase-locked its internal reference to the timing reference provided by GPS.

## To Send TL1 or SCPI Command to Obtain 55300A GPS Status

Ensure that the 55300A has been properly connected and configured for TL1 or SCPI communications. Refer to the section titled “Connecting the 55300A to a Terminal or Computer” on page 1-14.

### *Using TL1 Commands to Obtain 55300A GPS Status*

If your 55300A is being operated for the first time from the factory, or if security is disabled on your 55300A, simply type the following command to retrieve the 55300A’s status screen:

RTRV-PM-EQPT::<123::SYSTSTAT; and press Return.

The controller displays the Receiver Status screen as shown in the sample status screen in Figure 1-4 on page 1-24.

**You must re-enter the RTRV-PM-EQPT::<123::SYSTSTAT; command each time you want an updated status screen.**

If security has been enabled on your 55300A, type in following commands:

ACT-USER::SUPER:123::GPS-SYNC!;—to log on and begin a session (Note: the default <pid> or password is “GPS-SYNC!”).

RTRV-HDR::<123;—to get a normal response (COMPLD) indicating the cable and all communications links are viable.

RTRV-PM-EQPT::<123:SYSTSTAT;

### **Example**

- 1) To log on with the password SYNC-NIZ! and begin session, type the following:

ACT-USER::SUPER:123: :SYNC-NIZ!; and press Return.

The terminal will echo back:

ACT-USER::<123: :\*\*\*\*\*;

- 2) To establish that the controller is communicating properly with the 55300A, type the following:

RTRV-HDR::<123; and press Return.

The controller will echo back:

COMPLD;

3) To retrieve the 55300A's status screen, type the following:

RTRV-PM-EQPT:::123::SYSTSTAT; and press Return.

The controller displays the Receiver Status screen as shown in the sample status screen in Figure 1-4 on page 1-24.

**You must re-enter the RTRV-PM-EQPT:::123::SYSTSTAT; command each time you want an updated status screen.**

---

**NOTE**

You have been provided a Windows program called SatStat, which provides *continual status updates* of the 55300A's status screen. This program will have to be run by a personal computer (PC) that has Windows installed to operate it. The program is easy to install and operate.

See the section titled "Installing the Automated SatStat Program for Continual Status Updates" on page 1-25 in this guide.

---

### ***Using SCPI Commands to Obtain 55300A GPS Status***

Type in the following command:

:SYSTEM:STATUS? and press Enter (or Return).

If you typed in the command wrong a **E-xxx>** prompt is displayed after pressing Return. Try typing in the command again.

The computer displays the status screen as shown in the sample status screen in Figure 1-4 on page 1-24.

**You must re-enter the :SYSTEM:STATUS? command each time you want an updated status screen.**

---

**NOTE**

You have been provided a Windows program called SatStat, which provides *continual status updates* of the 55300A's status screen. This program will have to be run by a personal computer (PC) that has Windows installed to operate it. The program is easy to install and operate.

See the section titled "Installing the Automated SatStat Program for Continual Status Updates" on page 1-25 in this guide.

---

# Chapter 1 Getting Started

## Powering Up the 55300A

```
----- Receiver Status -----
SYNCHRONIZATION ..... [ Outputs Valid ]
SmartClock Mode _____ Reference Outputs _____
>> Locked to GPS          TFOM      3          FFOM      0
  Recovery                1PPS TI +7.2 ns relative to GPS
  Holdover                HOLD THR 1.000 us
  Power-up                Holdover Uncertainty _____
                          Predict  49.0 us/initial 24 hrs

ACQUISITION .....[GPS 1PPS Valid]
Tracking: 6 _____ Not Tracking: 1 _____
PRN  El  Az  SS  PRN  El  Az  Time _____ +1 leap second pending
  2   49 243 168   14  11  82  UTC      23:59:59   31 Dec 1995
 16   24 282 125   GPS 1PPS Synchronized to UTC
 18   38 154 132   ANT DLY  120 ns
 19   65  52 168   Position _____
 27   62 327 246   MODE      Survey: 17.5% complete
 31   34  61 133   AVG LAT  N  37:19:32.264
                          AVG LON  W 121:59:52.112
                          AVG HGT          +41.86 m (MSL)
ELEV MASK 10 deg
HEALTH MONITOR ..... [ OK ]
Self Test: OK Int Pwr: OK Oven Pwr: OK OCXO: OK EFC: OK GPS Rcv: OK
```

**Figure 1-4. Sample Status Screen**

If you need to customize the 55300A operation, see the section titled “Customizing the 55300A Operation” on page 1-27 for a list of key things you may want to perform to customize the operating parameters of the 55300A.

### To Understand the Receiver Status Screen Data

**One of the key indicators on the screen is the ACQUISITION status indicator.** It shows “GPS 1 PPS Valid” as soon as satellite information is sufficient.

Refer to Chapter 4, “Using the Receiver Status Screen,” in this guide for a tutorial on how to use the status screen (shown in Figure 1-4). A reference section that defines the different data indicated in the status screen is also provided in Chapter 4.

---

## Installing the Automated SatStat Program for Continual Status Updates

This Windows program provides, among other things, continual status updates of the 55300A or Receiver Status screen. Your PC must have Windows installed to operate the program. The program is easy to install and operate.

- 1** Insert the SatStat disk in drive A.
- 2** From the File menu in either the Program Manager or File Manager, choose Run.
- 3** Type **a:setup**, and click **OK** or press Enter (Return). The SatStat Setup screen will appear, and installation will proceed.
- 4** Once the program is installed, you can start it by double-clicking the **HP SatStat** icon that was created during the installation.
- 5** You should establish communication with the 55300A. This requires connection from a serial RS-232 port on your PC to the 55300A's **TIME OF DAY** port (see figures 1-3C and 1-3D). Assuming you've got the cable attached to make this connection, you may want to check the settings.

- a.** Select **CommPort**, then choose **Settings**.

The Communication Settings dialog box is displayed. Unless someone has reprogrammed the CommPort settings on the GPS Receiver, these settings are probably OK. *The one setting that is likely to need changing is the Com Port. The application defaults it to Com1, but the serial port on your PC may be assigned to a different Com Port. Select the appropriate setting. If you are unsure, Com1 will be your best bet (worst case, you can cycle through all of them until it works).*

- b.** If you made any changes on this Settings form, select **OK**, otherwise you can just **Cancel**.

## Operating the Automated SatStat Program

- 1 Select **CommPort**, then choose **Port Open**.

The main form of the Receiver Status screen is displayed. The program will send some commands to the 55300A and then the main form should begin to periodically update every few seconds. If you are getting screen updates, proceed to the next step. Otherwise, something is wrong with your CommPort settings or perhaps the physical connection between your PC and the 55300A.

If you need to control the 55300A or query for the status of a setting of the 55300A, use the “Control & Query” form (this form will usually be stacked beneath the main form). To activate this form, click anywhere on it. Select **Control** (or **Query**), then choose the type of control (or query) you want. This will pull down a list of control (or query) functions that you can choose from, and the corresponding command will be displayed. To send the command, click on **Send Cmd**. Hence, with the Control & Query form you can control the 55300A without knowing the command or query.

More information about the Windows program is provided in the “Getting Started” Help file.

- 2 Refer to Chapter 4, “Using the Receiver Status Screen,” of this guide for a tutorial and demonstration of what to look for when viewing the status screen.



---

## Customizing the 55300A Operation

Here are some things you might want to do to customize the 55300A operation:

- Execute a system preset if someone else has used the 55300A and left it in an unacceptable state.
- Make the 55300A survey if it wasn't already surveying.
- Set the antenna delay.
- Set the elevation mask angle.
- Set the time zone.

See the section titled “Using Commands to Control Key Functions (Examples)” on the following page for more information.

---

## Using Commands to Control Key Functions (Examples)

The operation of the 55300A is designed to be as automatic as possible. However, there are situations where serial interface control could be required. The tasks described here are those most commonly encountered.

For each task in this section, you can use either a terminal emulation program or the SatStat program to issue the selected commands. Additional information about the TL1 and SCPI commands is provided in the *55300A Programming Guide* (55300-90002).

### To Perform Basic Installation and Simple Customizing

After connecting the 55300A to the antenna, power source, RS-232 port, and after the self test is completed, you may want to complete installation using one or more of the capabilities described below.

***If required, restore all of the 55300A's internal settings to their factory shipment values by invoking a system preset.***

After executing the system preset, the 55300A will begin normal operation: it will acquire GPS signals, determine the date, time, and position automatically, bring the reference oscillator ovens to a stable operating temperature, lock the reference oscillator and its output to 10 MHz, and synchronize the 1 PPS output to UTC.

For TL1 commands, settings affected by system preset are listed in 55300A Programming Guide.

---

**NOTE**

---

Be sure to choose the correct command language for the 55310A/55320A/55322A port you are using.

The 55300A is preset using the command:

```
:INIT-SYS:::123::9;
```

or use the SCPI equivalent on the **TIME OF DAY** port

```
:SYSTEM:PRESET
```

Note that system preset should be performed only when necessary.

***Initiate “surveying”, an automatic determination of the 55300A’s antenna position.***

When “position survey” is invoked, the 55300A is set to ascertain the position of its antenna automatically. This survey is important; correct antenna position data is required for the 55300A to deliver specified performance.

The 55300A uses data from orbiting satellites to survey; hence, the antenna must be installed and operational for the survey to work. However, if you have a limited view of the sky, you can complete basic installation, then read forward to the section titled “To Install With a Limited View of the Sky, To Bypass Position Survey Operation” on page 1-30 for a means of overriding the survey operation and entering position data directly.

The survey is an iterative process. The 55300A transits to “Position Hold” after it has suitably refined its position estimate.

Set the 55300A to survey using command:

```
:INIT-SYS:::123::5;
```

or use the SCPI equivalent on the TIME OF DAY port

```
:GPSYSTEM:POSITION:SURVEY ONCE
```

***Set the 55300A to compensate for the length of the antenna cable.***

The 55300A can be custom-configured to compensate for the length of the antenna cable. The phase of the 55300A’s internal clock is offset by the value you enter with this command. The amount of error is typically on the order of a few hundred nanoseconds. Should you decide to correct for this error, tables 3-1A and 3-1B in Chapter 3, “Features and Functions,” of this guide provides typical corrections for standard antenna cable lengths.

Set the 55300A to compensate for antenna cable delay using the command:

```
ED-EQPT::GPS:123::ADEL=<nanoseconds>;
```

or use the SCPI equivalent on the TIME OF DAY port

```
:GPSYSTEM:REFERENCE:ADELAY <seconds>
```

It is normal to observe that the 55300A momentarily goes into holdover after any change in antenna delay.

**Using Commands to Control Key Functions (Examples)*****Set the 55300A to exclude satellites which appear below a specified elevation angle.***

At the factory, and whenever the 55300A is preset, the 55300A is set to seek satellites 10 degrees above the horizon—down to an “elevation mask angle” of 10 degrees. The 10 degrees setting provides a view of most of the sky while avoiding near-horizon satellites, which are more susceptible to atmospheric anomalies and multi-path effects. The 55300A can be custom-configured to use a different elevation mask angle.

Set the 55300A elevation mask angle using the command:

```
ED-EQPT::GPS:123::EMANGLE=<degrees>;
```

or use the SCPI equivalent on the **TIME OF DAY** port

```
:GPSSYSTEM:SAT:TRAC:EMANGLE <degrees>
```

***Set the 55300A to display local time rather than UTC time.***

Set the offset from UTC time to local time using the command:

```
ED-EQPT::GPS:123::TZONE=(-8)-0;
```

or use the SCPI equivalent on the **TIME OF DAY** port

```
:PTIME:TZONE <hours>, <minutes>
```

**To Install With a Limited View of the Sky,  
To Bypass Position Survey Operation**

In order to operate properly, the 55300A must know its position. The 55300A is able to collect enough information from four satellites to compute this position. The “position survey operation” takes in data from the satellites, iterating until the antenna position is known to the required precision. The 55300A will automatically use its position survey operation on powerup and :INIT:SYS::::9; (or SCPI equivalent :SYSTEM:PRESET).

Alternatively, if the antenna position is already known to seconds of arc, and the 55300A cannot see enough satellites, you may manually enter antenna position as shown in the following text.

---

**NOTE**

---

An incorrect value for the position will confuse the 55300A, and will degrade the timing information accuracy or even prevent tracking any satellites.

**Using Commands to Control Key Functions (Examples)**

Set the 55300A antenna position using the command format shown below (For clarity, an example is provided rather than a complex description.):

```
ED-EQPT::GPS:123::POS=N-37-19-32.5-W-121-59-51.2-4012;
```

or use the SCPI equivalent on the **TIME OF DAY** port

```
:GPS:POS N,37,19,32.5,W,121,59,51.2,40.12
```

Set the latitude, longitude, and height parameters to represent the latitude (in degrees, minutes, seconds), longitude (in degrees, minutes, seconds), and altitude in meters above mean sea level (MSL). (Note: if you know the position to this accuracy, the desired position is of the antenna rather than the 55300A.)

---

**NOTE**

---

For faster acquisition following repair, or power failure you may want to write down the position after the 55300A has completed its survey.



---

## Acceptance Test

Verifying Specifications

## Introduction

This chapter provides procedures to test the electrical performance of the 55300A GPS Telecom Primary Reference Source specifications listed in Chapter 5, “Specifications,” of this guide. Two types of testing are provided:

- Operational Verification, *starting on page 2-4*
- Acceptance Test, *starting on page 2-8*

### **Operational Verification**

The Operational Verification test is an abbreviated series of checks that may be performed to give a high degree of confidence that the instrument is operating properly without performing the Acceptance Test. An operational verification is useful for incoming inspection and after instrument repair.

### **Acceptance Test**

The Acceptance Test verifies the specifications listed in Chapter 5, “Specifications.” All tests can be performed without access to the inside of the instrument.

*Your 55300A has been tested to published specifications at the factory. The results of these tests are included with the product. (Insert these results in Appendix A, “Performance Test Information,” of this guide.) Please review these test results. Symmetricom does not require these tests to be performed as part of instrument installation. If you need these tests performed on your instrument, please contact your Symmetricom sales representative.*

*This chapter, however, provides Acceptance Test procedures, starting on page 2-8, if you choose to perform acceptance testing.*

### **Test Record**

The results of the Operational Verification, and Acceptance Test should be recorded on a copy of the Acceptance Test Record, located at the end of this chapter.



## Test Equipment Required

**Table 2-1. Recommended Test Equipment**

Instrument	Required Characteristics	Recommended Model	Use*
Digitizing Oscilloscope	<ul style="list-style-type: none"> <li>• Telecommunication Mask Test Software</li> <li>• 2 channels</li> <li>• 500 MHz bandwidth (repetitive)</li> <li>• 3.5 inch, 1.44 MB, MS-DOS®</li> </ul>	54520A (Monochrome) with Option 001 (or equivalent) or HP 54520C (Color) with Option 001 (or equivalent)	AT
HP Telecom Mask disk (or equivalent)	Telecom masks and oscilloscope setups	55300-13401	AT
Digitizing Oscilloscope	<ul style="list-style-type: none"> <li>• 2 channels</li> <li>• 500 MHz bandwidth (repetitive)</li> </ul>	HP 54600B (or equivalent)	OV, AT
Digital Multimeter (DMM)	Microvolt accuracy with test leads	HP 34401A (or equivalent)	OV, T
System DC Power Supply	-48 Vdc, 2 amps	HP 6633A (or equivalent)	AT, OV, T
Terminal or computer	Communication Software, RS-232 connection	Any Model	OV, AT
50Ω Feedthrough		HP 10100C (or equivalent)	OV
75Ω Feedthrough		HP 11094B (or equivalent)	AT
100Ω Feedthrough		3840-100 (Pomona®)	AT
75Ω Coaxial Cable with BNC connectors	BNC(m) to BNC(m), 48 inches	HP 15525A (or equivalent)	AT, OV
Coaxial BNC Tee Connector		1250-0781	AT
GPS Antenna or Antenna Assembly		58504A or 58513A	AT, OV
GPS Antenna Cable Assemblies	RG-213 or LMR400 cables, TNC-to-N	58518A, 58520A	AT, OV
GPS Interconnect Cable Assemblies	RG-213 or LMR400 cables, N-to-N	58519A, 58521A	AT, OV
BNC female to test Clips or BNC female to mini-hooks	18 AWG on alligator clips. One black and one red. or 20 AWG on mini-hooks. One black and one red.	Pomona Model 2630 or Pomona Model 3788	AT
Barrel adapter	N(f)-to-N(f)	HP 1250-0777 (or equivalent)	AT

\* OV = Operational Verification

AT = Acceptance Test

T = Troubleshooting

## 55300A Operational Verification

### Introduction

The 55300A GPS Telecom Primary Reference Source is designed to automatically detect and acquire satellites in order to begin providing precise frequency and time information. Until such acquisition is complete and the 55300A is locked, the signals produced on the rear or top front panel are not precise. However, it is possible to verify that the 55300A has been received in good working condition by performing some simple operational verification tests upon receipt.

The following operational verifications are designed to provide a high degree of confidence that the 55300A is functioning, but the verifications will not verify the specified performance characteristics. Only the critical 10 MHz and 1 PPS output signals are verified. (The telecom outputs are not verified the Operational Verification section; they are tested to specifications in the Acceptance Test section, starting on page 2-8 of this chapter.) As long as the 55300A is locked and the proper waveform signals are present at these two outputs, it implies that the other outputs are present and in conformance.

### **The 55300A requires no calibration.**

Verifying specifications requires more expensive equipment. Symmetricom recommends that you perform Acceptance Testing only after installation, and after any repairs are made to the 55300A.

**Record the results of the Operational Verification in the appropriate place on the 55300A Acceptance Test Record, which is located at the end of this chapter.**

### Preliminary Test Setup

If you have not connected the GPS antenna to the 55300A, perform the following preliminary procedure in this section.

If you have already connected the 55300A to the GPS antenna, go to the next subsection (titled 10 MHz Verification).

- 1 Connect the antenna system to the **GPS ANTENNA** Type-N connector of the 55310A/55320A/55322A as described in the instructions given in the subsection titled To Assemble and Install the Antenna System in Chapter 1, “Getting Started,” of this guide.

---

**NOTE**

*Do not apply power to the 55310A/55320A/55322A unless a fully operational antenna system is connected to the ANTENNA input connector. Power applied with no antenna input or a non-functioning antenna will initiate an extended search process that may increase time to reach GPS lock. You can halt the extended search by disconnecting and reconnecting (cycling) both of the external –48Vdc supplies to the 55310A/55320A/55322A (you may need to leave power disconnected for greater than five seconds).*

---

- 2** Apply the proper power source to the **POWER A –48VDC INPUT** jack or the **POWER B –48VDC INPUT** jack of the 55310A/55320A/55322A. (See the subsection titled “To Connect DC Power” in Chapter 1, “Getting Started,” of this guide.)

Verify that the following sequence of events occurs after installing the 55300A.

- a.** Only the front-panel **Power** indicator lights.
- b.** After a moment, the 55300A runs through its self-test diagnostics as indicated by the flashing front-panel indicators.
- c.** After the self test is completed, just the **Power** indicator remains illuminated.
- d.** After about 5 minutes, the 55300A may enter Major alarm condition as indicated by illumination of the front-panel **Major** indicator and activation of the Major alarm relay.

This ensures that all internal components and connections are functioning. It is normal operation for the **Major** indicator to be illuminated at this point. It is turned off or cleared when the 55300A is locked to GPS.

- 3** After tracking 4 or more satellites (this usually takes 5 to 10 minutes), the **Major** indicator turns off and the front-panel **GPS Lock** indicator should illuminate, indicating that the 55300A is locked to GPS.

## 10 MHz Verification

---

**NOTE**

---

If you are using the HP 54600B (or equivalent) Oscilloscope, use the HP 10100C (or equivalent) 50 $\Omega$  feedthrough on the input of the oscilloscope for the following operational verification tests.

- 1 Power up the HP 54600B (or equivalent) Oscilloscope, set the sweep rate (Time/Div) to 100 ns/div, and input amplitude to 0.5 Volts/div, ac coupled.
- 2 Connect the oscilloscope to the **10 MHz** output of the 55300A/55310A, or 55300A/55320A, or 55300A/55322A. Figure 2-1 shows the 55300A/55320A.

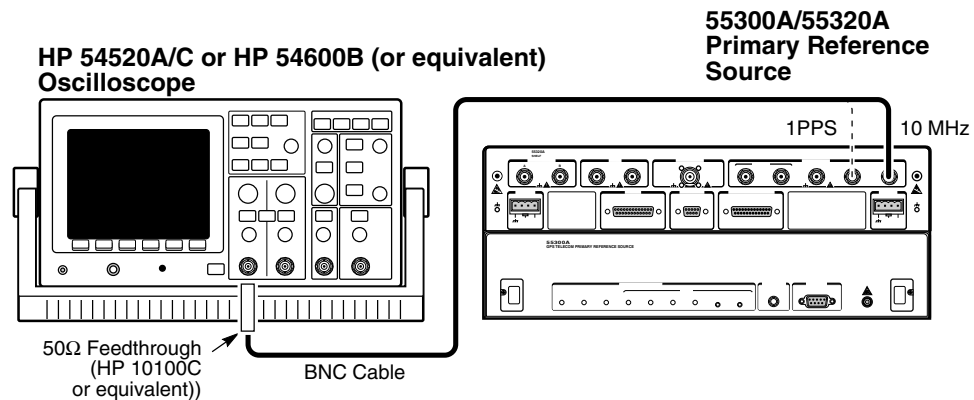

**Figure 2-1. 10 MHz and 1 PPS Operational Verification Setup (55300A/55320A shown)**

Verify that there is a 10 MHz sine wave present with approximately 2 Volt p-p into the 50 ohm load.

- 3 Mark Pass or Fail in Line 1 on the Operational Verification portion of the Acceptance Test Record, located at the end of this chapter.

## 1 PPS Verification

- 1 Connect the oscilloscope to the **1 PPS** output of 55300A/55310A, or 55300A/55320A, or 55300A/55322A. Figure 2-1 shows the 55300A/55320A.
- 2 Set the oscilloscope sweep rate to 10  $\mu$ s/div and amplitude to 5 Volts, dc-coupled. (You may have to adjust the trigger level, using the TRIGGER Level knob, to display the signal.)

## 55300A Operational Verification

Verify the presence of a TTL pulse with approximately 20  $\mu$ s pulse width.

- 3 Mark Pass or Fail in Line 2 on the Operational Verification portion of the Acceptance Test Record, located at the end of this chapter.

### Time of Day RS-232 Serial Interface Verification

- 1 Connect the 55300A to a terminal, PC, or laptop via the **TIME OF DAY** RS-232 port using cabling and connectivity instructions provided in the section titled Connecting the 55300A to a Terminal or Computer in Chapter 1, “Getting Started,” or the section titled “Connecting a Terminal/Computer or Modem” in Chapter 3, “Features and Functions,” of this guide.
- 2 Turn the PC on.
- 3 Using the configuration instructions given in the section titled “To Configure Terminal Communications for Windows-based PC,” or “To Configure Terminal Communications for DOS-based Only PC (No Windows),” or “To Configure Terminal Communications for HP 200LX (or Equivalent) Palmtop” in Chapter 1 of this guide, set the RS-232 port of your PC to match the following default values:

Pace:	NONE
Baud Rate:	9600
Parity:	NONE
Data Bits:	8
Stops Bits:	1

- 4 On the computer keyboard, press Enter (or Return).

Verify that either a **scpi>** or **E-xxx>** prompt is returned on the computer display. (The **E-xxx** prompt will appear if a pre-existing error occurred.)

- 5 From the computer keyboard, type

:PTIME:TCODE? and press Enter (or Return).

An alphanumeric string which starts with a “T” should be displayed as shown in the following example:

```
T2199505112055233000049
```

### **In Case of Difficulty**

- 6 Mark Pass or Fail in Line 3 on the Operational Verification portion of the Acceptance Test Record, located at the end of this chapter.

This completes the operational verification.

---

## **In Case of Difficulty**

If any of the above tests fail, the unit should be re-tested before assuming that it is defective. (**Note:** Make sure the front-panel mounting screws of the 55300A module are tightened, as shown in step 4 of Figure 1-1, before re-testing. Failure to tighten these screws can cause unreliable behavior.)

---

## **55300A Acceptance Test**

### **Testing Requirements**

Your 55300A has been tested to published specifications at the factory. The results of these tests are included with the product. (Insert these results in Appendix A, “Performance Test Information,” of this guide.) Please review these test results. Symmetricom does not require these tests to be performed as part of instrument installation. If you need these tests performed on your instrument, please contact your Symmetricom sales representative.

This chapter, however, has been provided if you choose to perform acceptance testing.

### **About the Acceptance Test**

The specifications of the 55300A can be verified by performing the Acceptance Test provided in this section. Table 2-2 lists the 55300A Acceptance Test.

Chapter 2 Acceptance Test  
**55300A Acceptance Test**

**Table 2-2. The 55300A Acceptance Test**

Page Number	Test Descriptions
2-10	<b>2048 kbps and 2048 kHz Tests—55300A/55320A/55322A Version Only, G703.6 (Table 6)/G703.10 (Table 10)</b>
2-10	Test 1: 2048 kbps—Using the Waveform Mask Capability of the HP 54520A/C (or Equivalent) Oscilloscope
2-11	Test 2: 2048 kHz—Using the Waveform Mask Capability of the HP 54520A/C (or equivalent) Oscilloscope
2-15	Test 1': 2048 kbps Test—Using an HP 54600B (or Equivalent) Oscilloscope Without Waveform Mask Capability
2-17	Test 2': 2048 kHz Test—Using an HP 54600B (or Equivalent) Oscilloscope Without Waveform Mask Capability
2-20	<b>1544 kbps and 1544 kHz Tests—55300A/55310A (T1) Version Only, G703.4 (Table 4)/G703.10 (Table 10)</b>
2-20	Test 1A: 1544 kbps Test—Using the Waveform Mask Capability of the HP 54520A/C (or Equivalent) Oscilloscope
2-21	Test 2A: 1544 kHz Test—Using the Waveform Mask Capability of the HP 54520A/C (or Equivalent) Oscilloscope
2-22	Test 1A': 1544 kbps Test—Using an HP 54600B (or Equivalent) Oscilloscope Without Waveform Mask Capability
2-24	Test 2A': 1544 kHz Test—Using an HP 54600B (or Equivalent) Oscilloscope Without Waveform Mask Capability

The following tests will ensure that the 55300A GPS Telecom Primary Reference Source is meeting the specifications that are listed in Chapter 5, “Specifications,” in this guide.

**Record the results of the Acceptance Test in the appropriate place on the 55300A Acceptance Test Record, which is located at the end of this chapter.**

These tests verify that the telecommunications (2048 kbps/kHz, 1544 kbps/kHz) outputs from the 55300A are within specified requirements.

## **2048 kbps and 2048 kHz Tests—55300A/55320A/55322A Version Only, G703.6/G703.10**

*Perform these tests only if you are testing the 55300A/55320A/55322A version of the GPS Telecom Primary Reference Source.*

If you have not connected the GPS antenna to the 55300A, perform the procedure described in the section titled Preliminary Test Setup starting on page 2-4 of this chapter.

### **Test 1: 2048 kbps—Using the Waveform Mask Capability of the HP 54520A/C (or Equivalent) Oscilloscope**

---

**NOTE**

Use the HP 11094B (or equivalent) 75 $\Omega$  feedthrough and HP 15525A (or equivalent) 75 $\Omega$  BNC cable on the input of the oscilloscope for the following 2048 kbps test.

- 1** Connect a 75 $\Omega$  feedthrough (HP 11094B) (or equivalent) to the appropriate input channel of the HP 54520A/C (or equivalent) Oscilloscope as shown in Figure 2-2.
- 2** Connect the corresponding input of the oscilloscope to the **2048 kbps** output of the 55320A/55322A, using the HP 15525A (or equivalent) 75 $\Omega$  BNC cable as shown in Figure 2-2.



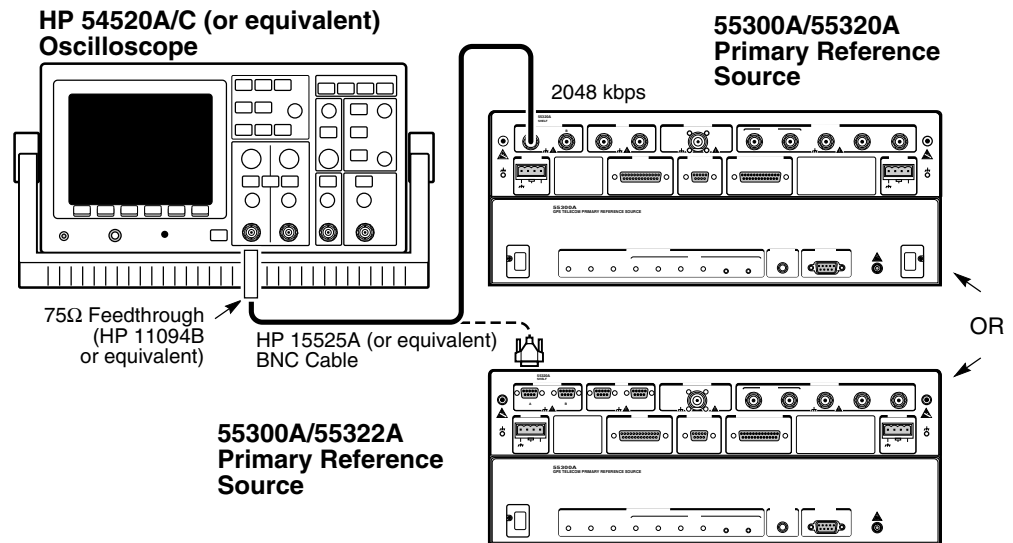

**Figure 2-2. 2048 kbps Test Setup**

- 3 Perform the entire procedure in the subsection titled “Telecom Masks and HP 54520A/C (or Equivalent) Oscilloscope Setups” starting on page 2-12 of this chapter. *When performing the Telecom Mask procedure, be sure to test the 2048 kbps waveform against both the G703\_6 and G703\_6I masks.*
- 4 Mark Pass or Fail in Test 1 line of the 55300A/55320A/55222A Acceptance Test Record, located at the end of this chapter.

This completes the 2048 kbps waveform test.

**Test 2: 2048 kHz—Using the Waveform Mask Capability of the HP 54520A/C (or equivalent) Oscilloscope**

**NOTE**

Use the HP 11094B (or equivalent) 75Ω feedthrough and HP 15525A (or equivalent) 75Ω BNC cable on the input of the oscilloscope for the following 2048 kHz test.

**2048 kbps and 2048 kHz Tests—55300A/55320A/55322A Version Only, G703.6/G703.10**

- 1 Connect a 75Ω feedthrough (HP 11904B) (or equivalent) to the appropriate input channel of the HP 54520A/C (or equivalent) Oscilloscope as shown in Figure 2-3.

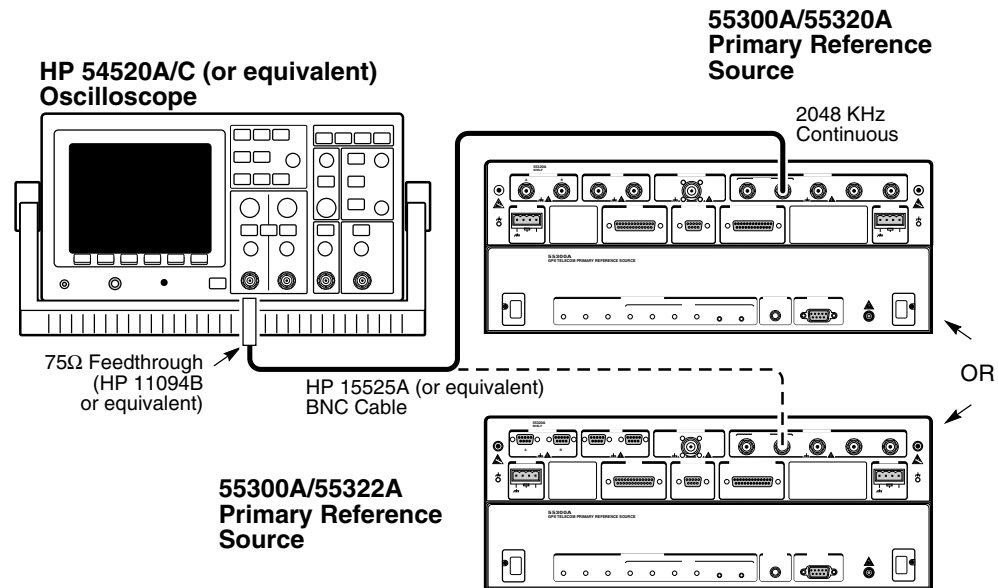

**Figure 2-3. 2048 kHz Test Setup**

- 2 Connect the corresponding input of the oscilloscope to the **2048 kHz/Continuous** output of the 55320A/55322A, using the HP15525A (or equivalent) 75Ω BNC cable as shown in Figure 2-3.
- 3 Perform the procedure in the subsection titled “Telecom Masks and HP 54520A/C (or Equivalent) Oscilloscope Setups” below. *When performing the Telecom Mask procedure, be sure to test the 2048 kHz waveform against both the G703\_10 and G703\_10I masks.*
- 4 Mark Pass or Fail in Test 2 line of the 55300A/55320A/55222A Acceptance Test Record, located at the end of this chapter.

This completes the 2048 kHz waveform test.

**Telecom Masks and HP 54520A/C (or Equivalent) Oscilloscope Setups**

- 1 Power up the oscilloscope, and press **Autoscale** to preset the oscilloscope.
- 2 Insert disk (55300-13401) with telecom masks and oscilloscope setups in the oscilloscope disk drive.

- 3 On the oscilloscope, press blue **Shift** key, then press **Applications/Utility** key.

This displays the telecom mask menu.

- 4 In the telecom mask menu, ensure that **MASK** is highlighted in the first menu box; if not, select **MASK** by pressing the adjacent softkey.
- 5 Use the **ENTRY/MEASURE** knob to select the appropriate mask for the signal under test, for example:

G703\_6 (for 2048 kbps signal)

or

G703\_10 (for 2048 kHz signal)

or

ANSI\_POS (for 1544 kbps signal)

or

T1\_75\_SC (for 1544 kHz signal)

As you turn the knob, the **MSK FILES** menu box (fourth menu box) displays the mask of the signal under test; stop when the mask for the signal under test is displayed.

- 6 Press **LOAD SETUP8** softkey.

The scope will load the positive pulse mask in memory location 8.

- 7 To recall the positive mask for testing, press **Recall**, then number **8**.

- 8 Select **COMPARE** in the first menu box.

- 9 Set **COMPARE CHAN 1** to **ON** in the second menu box.

- 10 Set **AFTER FAIL** to **CONTINUE** in the bottom menu box.

- 11 Press the **Run** key.

**PASS** should be displayed in the upper left corner of the scope's display.

- 12 To check the inverse of the signal, select **MASK** in the first menu box.

**2048 kbps and 2048 kHz Tests—55300A/55320A/55322A Version  
Only, G703.6/G703.10**

- 13** Use the **ENTRY/MEASURE** knob to select the inverse mask for the signal under test, for example:

G703\_6I (for 2048 kbps signal)

or

G703\_10I (for 2048 kHz signal )

or

ANSI\_NEG (for 1544 kbps signal)

- 14** Press **LOAD SETUP8** softkey.

The scope will load the negative pulse mask in memory location 8.

- 15** To recall the negative mask for testing, press **Recall**, then number **8**.

- 16** Select **COMPARE** in the first menu box.

- 17** Set **COMPARE CHAN 1** to **ON** in the second menu box.

- 18** Set **AFTER FAIL** to **CONTINUE** in the bottom menu box.

- 19** Press the **Run** key.

**PASS** should be displayed in the upper left corner of the scope's display.

- 20** Return to the test procedure you were performing.

**Test 1: 2048 kbps Test—Using an HP 54600B (or Equivalent) Oscilloscope Without Waveform Mask Capability****NOTE**

Use the HP 11094B (or equivalent) 75 $\Omega$  feedthrough and HP 15525A (or equivalent) 75 $\Omega$  BNC cable on the input of the oscilloscope for the following 2048 kHz test.

- 1 Connect a 75 $\Omega$  feedthrough (HP 11094B) (or equivalent) to the appropriate input channel of the HP 54600B (or equivalent) Oscilloscope as shown in Figure 2-4.
- 2 Connect the corresponding input of the oscilloscope to the **2048 kbps** output of the 55320A/55322A, using the HP 15525A (or equivalent) 75 $\Omega$  BNC cable as shown in Figure 2-4.

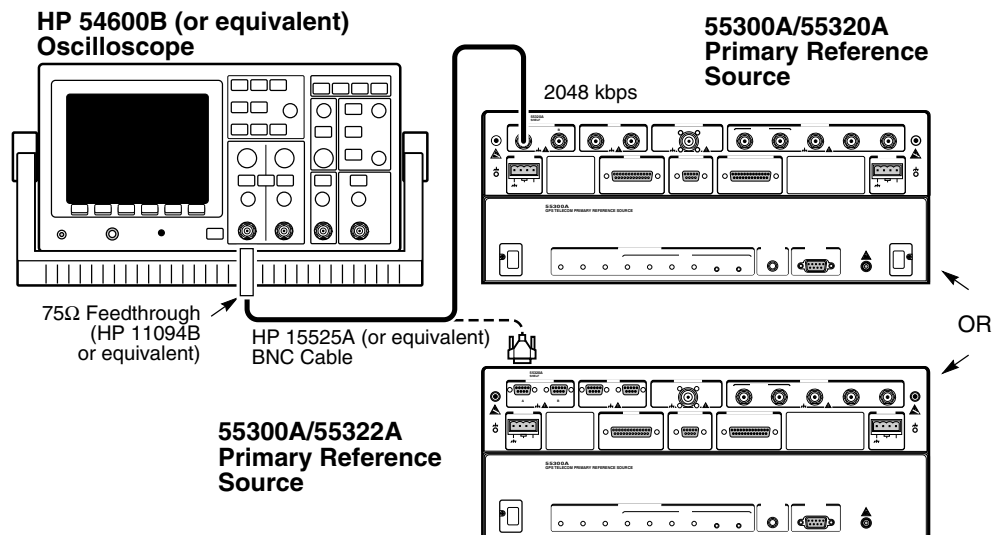
**Figure 2-4. 2048 kbps Test Setup**

- 3 On the HP 54600B (or equivalent) Oscilloscope, set the time base to 100 ns/div, and channel amplitude to 1.0 V/div. Adjust trigger level as needed to get a stable signal.
- 4 Verify that the 2048 kbps positive signal (A) has a voltage peak of 2.37 Volts  $\pm$ 0.237 Volts (i.e., the range is from 2.133 to 2.607 Volts) as shown in Figure 2-5.

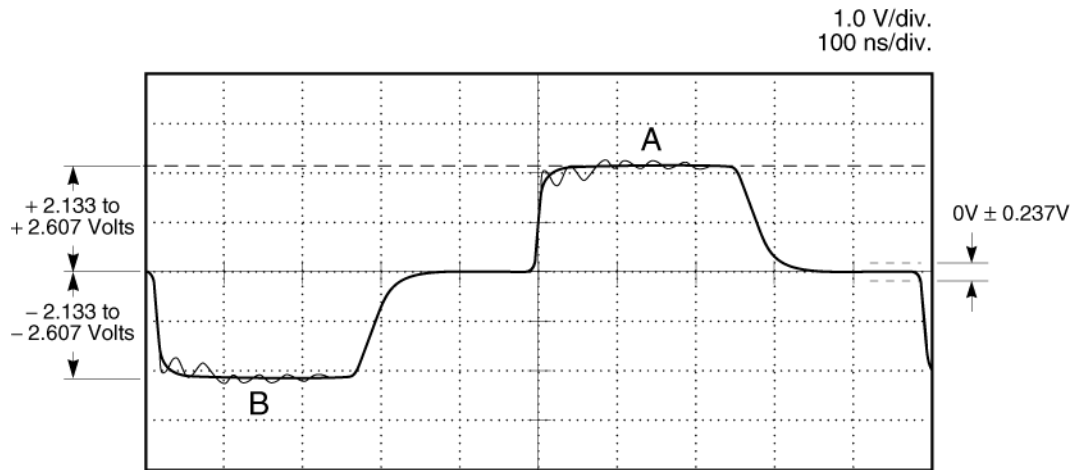

**Figure 2-5. 2048 kbps Voltage Peak Test**

- 5 Record the actual reading in Test 1' of the 55300A/55320A/55322A Acceptance Test Record (Test 1', Line 1).
- 6 Verify that the 2048 kbps inverse signal (B) has a voltage peak of  $-2.37 \text{ Volts} \pm 0.237 \text{ Volts}$  (i.e., the range is from  $-2.133$  to  $-2.607$  Volts) as shown in Figure 2-5.
- 7 Record the actual reading in Test 1' of the 55300A/55320A/55322A Acceptance Test Record (Test 1', Line 2).
- 8 Verify the 2048 kbps positive signal (A) has a pulse width of  $244 \text{ ns} \pm 25 \text{ ns}$  (i.e., the range is from 219 to 269ns) as shown in Figure 2-6.

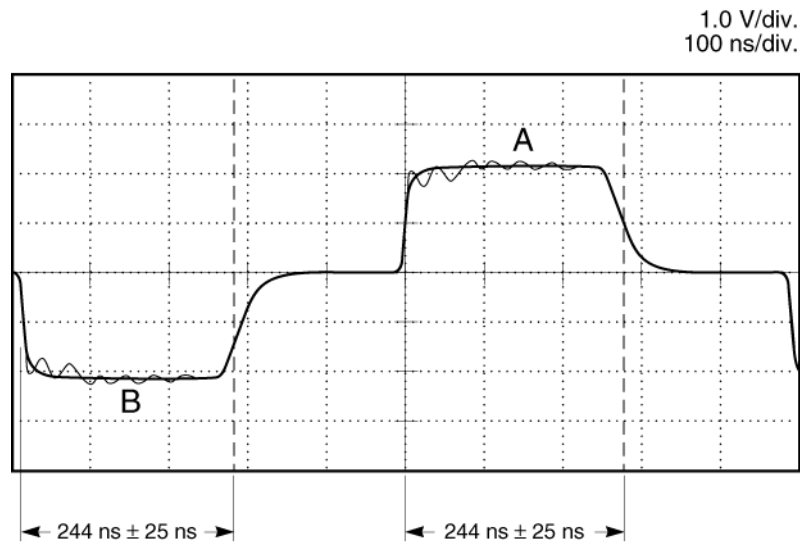

**Figure 2-6. 2048 kbps Pulse Width at 50% Test**

- 9 Record the actual reading in Test 1' of the 55300A/55320A/55322A Acceptance Test Record (Test 1', Line 3).
- 10 Verify the 2048 kbps inverse signal (B) has a pulse width of 244 ns  $\pm$ 25ns (i.e., the range is from 219 to 269 ns) as shown in Figure 2-6.
- 11 Record the actual reading in Test 1' of the 55300A/55320A/55322A Acceptance Test Record (Test 1', Line 4).

This completes the 2048 kbps waveform test.

### **Test 2: 2048 kHz Test—Using an HP 54600B (or Equivalent) Oscilloscope Without Waveform Mask Capability**

---

**NOTE**

---

Use the HP 11094B (or equivalent) 75 $\Omega$  feedthrough and HP 15525A (or equivalent) 75 $\Omega$  BNC cable on the input of the oscilloscope for the following 2048 kHz test.

- 1 Connect a 75 $\Omega$  feedthrough (HP 11904B) (or equivalent) to the appropriate input channel of the HP 54600B (or equivalent) Oscilloscope as shown in Figure 2-7.
- 2 Connect the corresponding input of the oscilloscope to the rear-panel **2048 kHz** output of the 55320A/55322A, using the HP 15525A (or equivalent) 75 $\Omega$  BNC cable as shown in Figure 2-7.

**2048 kbps and 2048 kHz Tests—55300A/55320A/55322A Version Only, G703.6/G703.10**

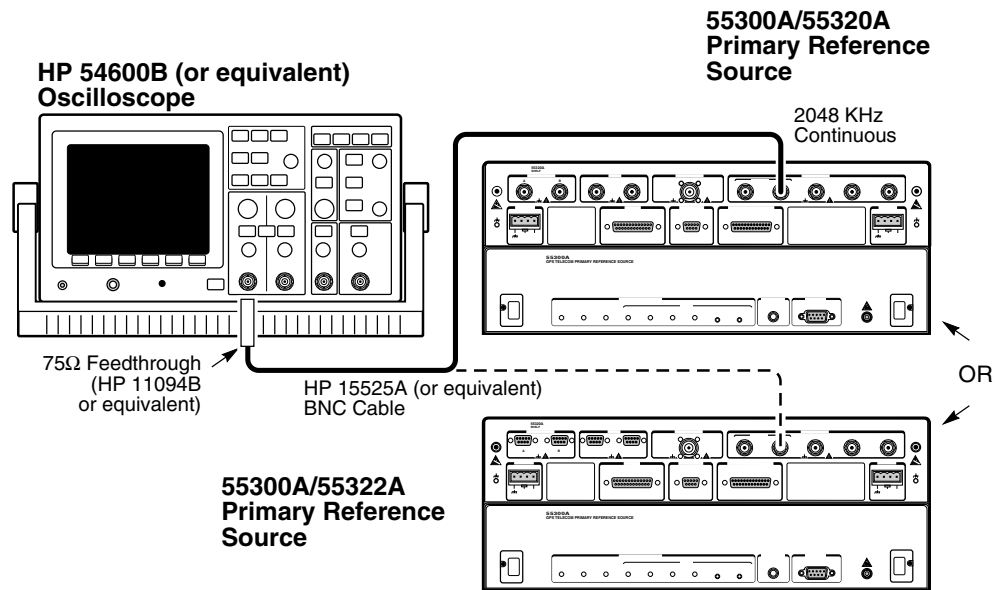

**Figure 2-7. 2048 kHz Test Setup**

- 3 On the HP 54600B (or equivalent) Oscilloscope, set the time base to 100ns/div, and channel amplitude to 500mV/div. Adjust trigger level as needed to get a stable signal.
- 4 Verify that the 2048 kHz positive signal (A) has a maximum voltage peak of 1.5 Volts and a minimum voltage peak of 0.75 Volts (i.e., the voltage range should be 0.75 to 1.5 Volts) as shown in Figure 2-8.



**Figure 2-8. 2048 kHz Volt Peak Test**

- 5 Record the actual reading in Test 2' of the 55300A/55320A/55322A Acceptance Test Record (Test 2', Line 1).



**2048 kbps and 2048 kHz Tests—55300A/55320A/55322A Version Only, G703.6/G703.10**

- 6 Verify that the 2048 kHz inverse signal (B) has a voltage peak  $-1.5$  Volts and a minimum voltage peak of  $-0.75$  Volts (i.e., the voltage range should be  $-0.75$  to  $-1.5$  Volts) as shown in Figure 2-8.
- 7 Record the actual reading in Test 2' of the 55300A/55320A/55322A Acceptance Test Record (Test 2', Line 2).
- 8 Verify the 2048 kHz positive signal (A) has a pulse width of  $244 \text{ ns} \pm 25 \text{ ns}$  (i.e., the range is from 219 to 269 ns) as shown in Figure 2-9.



**Figure 2-9. 2048 kHz Pulse Width Test**

- 9 Record the actual reading in Test 2' of the 55300A/55320A/55322A Acceptance Test Record (Test 2', Line 3).
- 10 Verify the 2048 kHz inverse signal (B) has a pulse width of  $244 \text{ ns} \pm 25 \text{ ns}$  (i.e., the range is from 219 to 269 ns) as shown in Figure 2-9.
- 11 Record the actual reading in Test 2' of the 55300A/55320A/55322A Acceptance Test Record (Test 2', Line 4).

This completes the 2048 kHz waveform test.

## 1544 kbps and 1544 kHz Tests—55300A/55310A (T1) Version Only, G703.4/G703.10

*Perform these tests only if you are testing the 55300A/55310A version of the GPS Telecom Primary Reference Source.*

If you have not connected the GPS antenna to the 55300A, perform the procedure described in the section titled “Preliminary Test Setup” starting on page 2-4 of this chapter.

### Test 1A: 1544 kbps Test—Using the Waveform Mask Capability of the HP 54520A/C (or Equivalent) Oscilloscope

- 1 Connect a 100 $\Omega$  feedthrough (3840-100, Pomona®) to the appropriate input channel of the HP 54520A/C (or equivalent) Oscilloscope as shown in Figure 2-10.
- 2 Connect a 1:1 oscilloscope probe to the **T** pin and connect the probe's ground wire to the **R** pin on the rear-panel **DSI** wire-wrap connector of the 55310A as shown in Figure 2-10. Now, connect the probe to the appropriate 100 $\Omega$  terminated oscilloscope input.

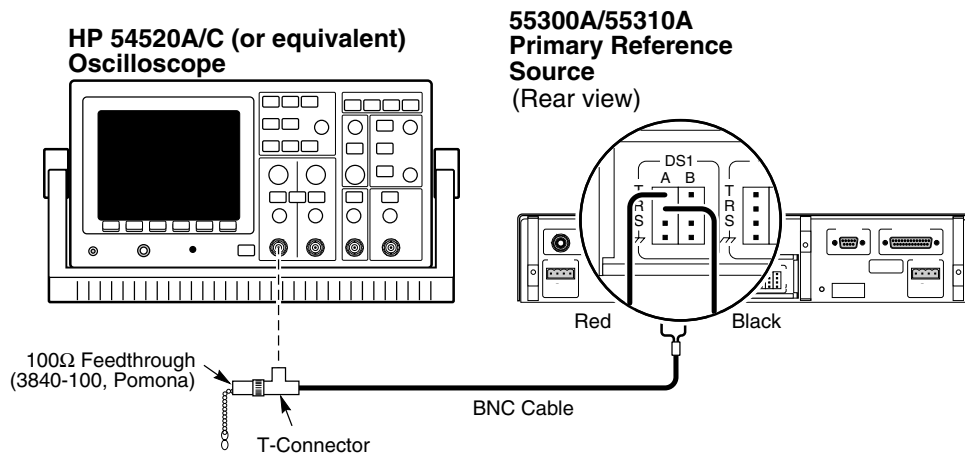

**Figure 2-10. 1544 kbps Test Setup**

**1544 kbps and 1544 kHz Tests—55300A/55310A (T1) Version Only, G703.4/G703.10**

- 3 Perform the procedure in the subsection titled “Telecom Masks and HP 54520A/C (or Equivalent) Oscilloscope Setups” starting on page 2-12 of this chapter. *When performing the Telecom Mask procedure, be sure to test the 1544 kbps waveform against both the ANSI\_POS and ANSI\_NEG masks.*
- 4 Mark Pass or Fail in Test 1A line of the 55300A/55310A Acceptance Test Record, located at the end of this chapter.

This completes the 1544 kbps waveform test.

**Test 2A: 1544 kHz Test—Using the Waveform Mask Capability of the HP 54520A/C (or Equivalent) Oscilloscope****NOTE**

Use the HP 11094B (or equivalent) 75Ω feedthrough and HP 15525A (or equivalent) 75Ω BNC cable on the input of the oscilloscope for the following 1544 kHz test.

- 1 Connect a 75Ω feedthrough (HP 11904B) (or equivalent) to the appropriate input channel of the HP 54520A/C (or equivalent) Oscilloscope as shown in Figure 2-11.
- 2 Connect the corresponding input of the oscilloscope to the rear-panel **Output A** output of the 55310A, using the HP 15525A (or equivalent) 75Ω BNC cable as shown in Figure 2-11.

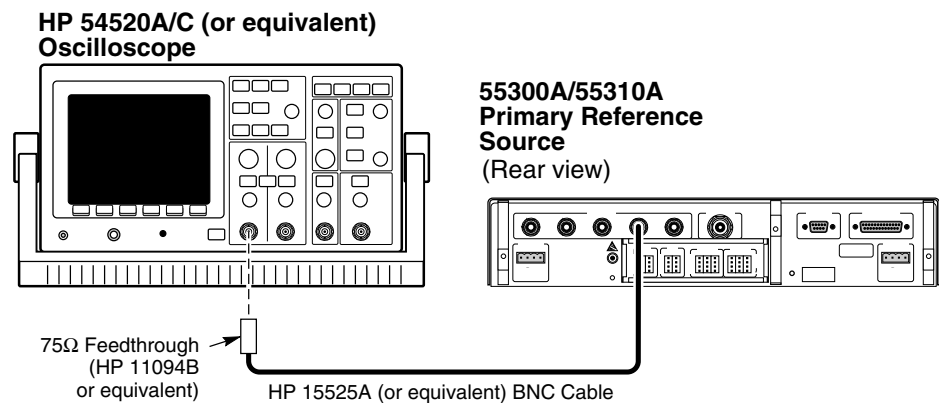
**Figure 2-11. 1544 kHz Test Setup**

- 3 Perform the procedure in the subsection titled “Telecom Masks and HP 54520A/C (or Equivalent) Oscilloscope Setups” starting on page 2-12 of this chapter. *When performing the Telecom Mask procedure, test the 1544 kHz waveform against the GT1\_75\_SC mask.*

### 1544 kbps and 1544 kHz Tests—55300A/55310A (T1) Version Only, G703.4/G703.10

- 4 Mark Pass or Fail in Test 2A line of the 55300A/55310A Acceptance Test Record, located at the end of this chapter.

This completes the 1544 kHz waveform test.

### Test 1A: 1544 kbps Test—Using an HP 54600B (or Equivalent) Oscilloscope Without Waveform Mask Capability

- 1 Connect a 100 $\Omega$  feedthrough (3840-100, Pomona®) to the appropriate input channel of the HP 54600B (or equivalent) Oscilloscope as shown in Figure 2-12.

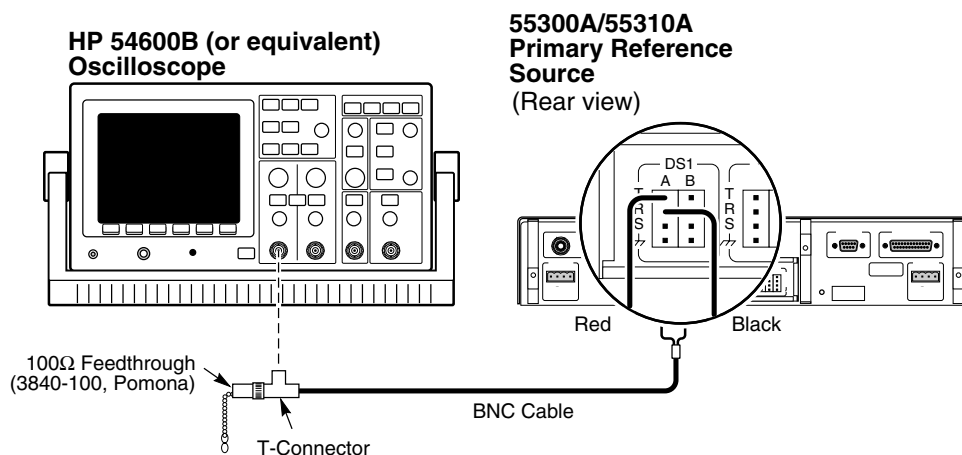

**Figure 2-12. 1544kbps Test Setup**

- 2 Connect a 1:1 oscilloscope probe to the **T** pin and connect the probe's ground wire to the **R** pin on the rear-panel **DSI** wire-wrap connector of the 55310A as shown in Figure 2-12. Now, connect the probe to the appropriate 100 $\Omega$  terminated oscilloscope input.
- 3 On the HP 54600B (or equivalent) Oscilloscope, set the time base to 200 ns/div, and channel amplitude to 1.0 V/div. Adjust trigger level as needed to get a stable signal.
- 4 Verify that the 1544 kbps positive signal (A) has a positive amplitude of 3.0 Volts +0.45V or -0.15 Volts (i.e., the range is from +2.85 to 3.45 Volts) as shown in Figure 2-13.

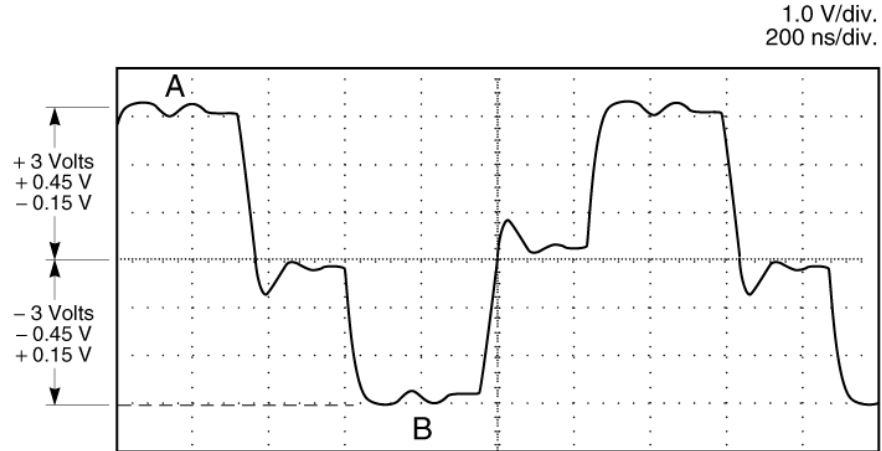

**Figure 2-13. 1544 kbps Amplitude Test**

- 5 Record the actual reading in Test 1A' of the 55300A/55310A Acceptance Test Record (Test 1A', Line 1).
- 6 Verify that the 1544 kbps inverse signal (B) has a negative amplitude of  $-3.0 \text{ Volts} - 0.45 \text{ V}$  or  $+0.15 \text{ Volts}$  (i.e., the range is from  $-2.85$  to  $-3.45 \text{ Volts}$ ) as shown in Figure 2-13.
- 7 Record the actual reading in Test 1A' of the 55300A/55310A Acceptance Test Record (Test 1A', Line 2).
- 8 Verify the 1544 kbps positive signal (A) has a pulse width of  $340 \text{ ns} \pm 60 \text{ ns}$  (i.e., the range is from  $280$  to  $400 \text{ ns}$ ) as shown in Figure 2-14.

**1544 kbps and 1544 kHz Tests—55300A/55310A (T1) Version Only,  
G703.4/G703.10**

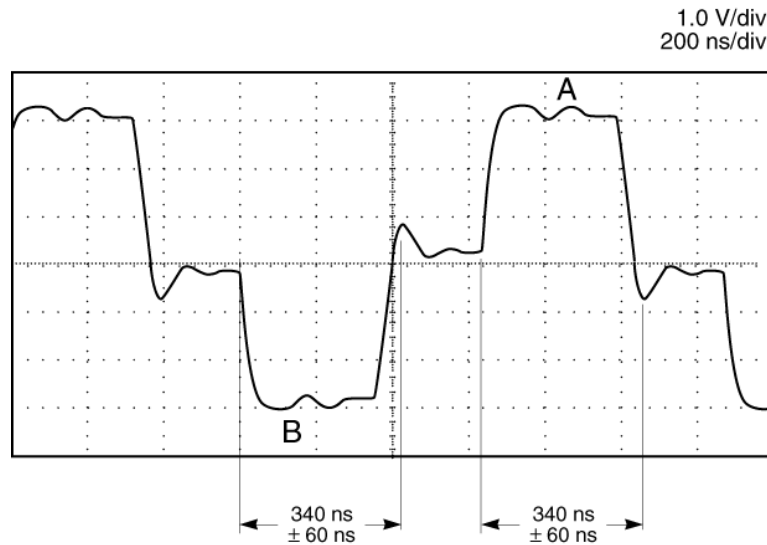

**Figure 2-14. 1544 kbps Pulse Width at 50% Test**

- 9 Record the actual reading in Test 1A' of the 55300A/55310A Acceptance Test Record (Test 1A', Line 3).
- 10 Verify the 1544 kbps inverse signal (B) has a pulse width of 340 ns ±60 ns (i.e., the range is from 280 to 400 ns) as shown in Figure 2-14.
- 11 Record the actual reading in Test 1A' of the 55300A/55310A Acceptance Test Record (Test 1A', Line 4).

This completes the 1544 kbps waveform test.

**Test 2A: 1544 kHz Test—Using an HP 54600B (or Equivalent) Oscilloscope Without Waveform Mask Capability**

**NOTE**

Use the HP 11094B (or equivalent) 75Ω feedthrough and HP 15525A (or equivalent) 75Ω BNC cable on the input of the oscilloscope for the following 1544 kHz test.

- 1 Connect a 75Ω feedthrough (HP 11904B) (or equivalent) to the appropriate input channel of the HP 54600B (or equivalent) Oscilloscope as shown in Figure 2-15.
- 2 Connect the corresponding input of the oscilloscope to the rear-panel **Output A** output of the 55310A, using the HP 15525A (or equivalent) 75Ω BNC cable as shown in Figure 2-15.

**1544 kbps and 1544 kHz Tests—55300A/55310A (T1) Version Only,  
G703.4/G703.10**

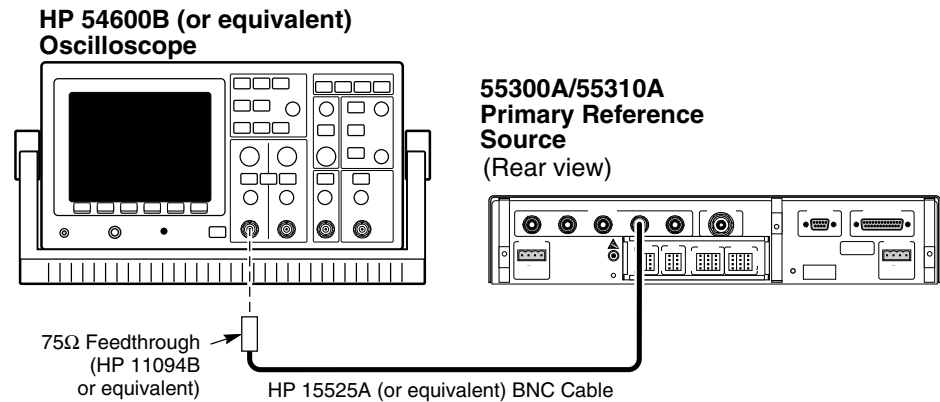

**Figure 2-15. 1544 kHz Test Setup**

- 3 On the HP 54600B (or equivalent) Oscilloscope, set the time base to 200 ns/div, and channel amplitude to 500 mV/div. Adjust trigger level as needed to get a stable signal.
- 4 Verify that the 1544 kHz positive signal (A) has a maximum positive voltage of 1.5 Volts and a minimum voltage peak of 0.75 Volts (i.e., the voltage range should be 0.75 to 1.5 Volts) as shown in Figure 2-16.

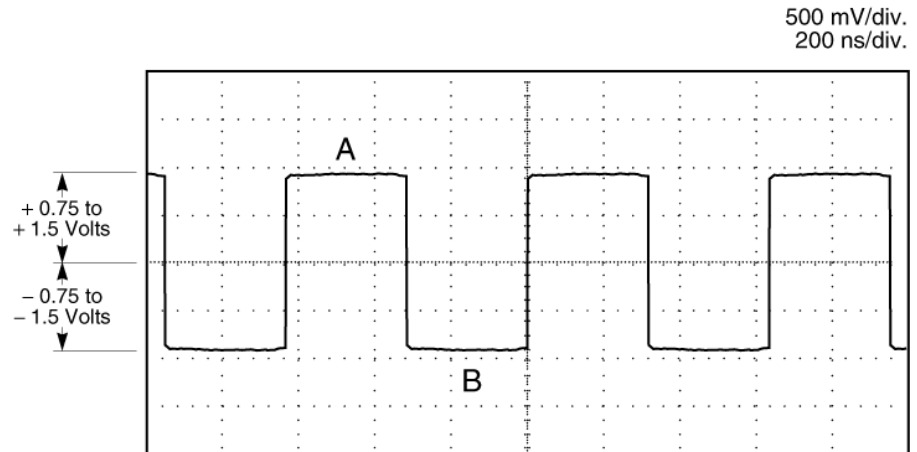
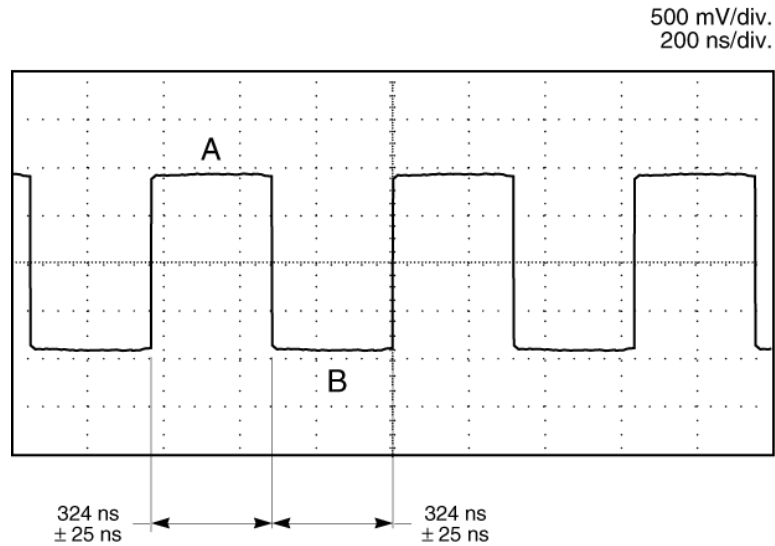

**Figure 2-16. 1544 kHz Volt Peak Test**

- 5 Record the actual reading in Test 2A' of the 55300A/55310A Acceptance Test Record (Test 2A', Line 1).
- 6 Verify that the 1544 kHz inverse signal (B) has a maximum negative voltage of -1.5 Volts and a minimum voltage peak of -0.75 Volts (i.e., the voltage range should be 0.75 to 1.5 Volts) as shown in Figure 2-16.

**1544 kbps and 1544 kHz Tests—55300A/55310A (T1) Version Only,  
G703.4/G703.10**

- 7 Record the actual reading in Test 2A' of the 55300A/55310A Acceptance Test Record (Test 2A', Line 2).
- 8 Verify the 1544 kHz positive signal (A) has a pulse width of 324 ns  $\pm$ 25ns (i.e., the range is from 299 ns to 349 ns) as shown in Figure 2-17.



**Figure 2-17. 1544 kHz Pulse Width Test**

- 9 Record the actual reading in Test 2A' of the 55300A/55310A Acceptance Test Record (Test 2A', Line 3).
- 10 Verify the 1544 kHz inverse signal (B) has a negative pulse width of 324 ns  $\pm$ 25 ns (i.e., the range is from 299 ns to 349 ns) as shown in Figure 2-17.
- 11 Record the actual reading in Test 2A' of the 55300A/55310A Acceptance Test Record (Test 2A', Line 4).

This completes the 1544 kHz waveform test.



## 55300A Acceptance Test Record (Page 1 of 2)

<b>Model 55300A GPS Telecom Primary Reference Source</b>				
Serial Number: _____ Repair/Work Order No. _____				
Test Performed By: _____ Temperature: _____				
Date: _____ Relative Humidity: _____				
Notes: _____				
Line Number	Operational Verification	Test Results		
		Pass	Fail	
<b>1</b>	10 MHz Verification	___	___	
<b>2</b>	1 PPS Verification	___	___	
<b>3</b>	Time of Day RS-232 Serial Interface Verification	___	___	
<b>55300A/55320A/55322A Acceptance Test</b>				
Test Number	Test Description	Test Results		
		Pass	Fail	
<b>1</b>	2048 kbps Test Using the Waveform Mask Capability	___	___	
<b>2</b>	2048 kHz Test Using the Waveform Mask Capability	___	___	
Test Number	Test Description	Minimum	Actual Reading	Maximum
<b>1'</b>	2048 kbps Test <i>Without</i> Using the Waveform Mask Capability	+2.133 V	1. _____	+2.133 V
		-2.133 V	2. _____	-2.133 V
		219 ns	3. _____	269 ns
		219 ns	4. _____	269 ns
<b>2'</b>	2048 kHz Test <i>Without</i> Using the Waveform Mask Capability	+0.75 V	1. _____	+1.5 V
		-0.75 V	2. _____	-1.5 V
		219 ns	3. _____	269 ns
		219 ns	4. _____	269 ns

## 55300A Acceptance Test Record (Page 2 of 2)

<b>55300A/55310A Acceptance Test</b>				
<b>Test Number</b>	<b>Test Description</b>	<b>Test Results</b>		
		<b>Pass</b>	<b>Fail</b>	
<b>1A</b>	1544 kbps Test Using the Waveform Mask Capability	0	0	
<b>2A</b>	1544 kHz Test Using the Waveform Mask Capability	0	0	
<b>Test Number</b>	<b>Test Description</b>	<b>Minimum</b>	<b>Actual Reading</b>	<b>Maximum</b>
<b>1A'</b>	1544 kbps Test <i>Without</i> Using the Waveform Mask Capability	+2.85 V	1. _____	+3.45 V
		-2.85 V	2. _____	-3.45 V
		280 ns	3. _____	400 ns
		280 ns	4. _____	400 ns
<b>2A'</b>	1544 kHz Test <i>Without</i> Using the Waveform Mask Capability	+0.75 V	1. _____	+1.5 V
		-0.75 V	2. _____	-1.5 V
		299 ns	3. _____	349 ns
		299 ns	4. _____	349 ns



---

## Chapter Contents

You will find that this chapter makes it easy to look up the details about a particular feature of the 55300A GPS Telecom Primary Reference Source. This chapter provides product inputs, outputs, indicators, controls, terminal and computer connections, operating concepts (GPS lock and holdover), and problem-solving information.

This chapter is organized as follows:

- Inputs page 3-4
  - GPS ANTENNA Input page 3-4
  - POWER A and B –48 VDC Inputs page 3-7
  - ESD Chassis Ground Connection page 3-7
- Telecommunication Frequency Outputs page 3-8
  - MONITOR Output page 3-9
  - DS1 Wire-Wrap Connector Outputs  
(55300/55310A Only) page 3-9
  - Output A and B (55300A/55310A Only) page 3-10
  - 2048 kbps Outputs (55300A/55320A/55322A Only) page 3-11
  - 2048 kHz Outputs (55300A/55320A/55322A Only) page 3-13
- Time and Frequency Outputs page 3-14
  - 10 MHz Output page 3-14
  - 1 PPS (One Pulse Per Second) Output page 3-14
  - IRIG-B Output page 3-14
  - 1 PPS Wire-Wrap Connector Outputs  
(55300/55310A Only) page 3-16
  - 1 PPS Negative and Positive Outputs  
(55300A/55320A/55322A Only) page 3-16
- Indicators page 3-18
  - Power Indicator page 3-18
  - GPS Lock Indicator page 3-18
  - Holdover Indicator page 3-18
  - Critical Alarm Indicator page 3-19
  - Major Alarm Indicator page 3-19
  - Minor Alarm Indicator page 3-19
  - ACO Active Indicator page 3-19

**Chapter Contents**

• Controls	page 3-20
– ACO Pushbutton Control	page 3-20
– ACO Reset Pushbutton Control	page 3-20
– Local (with ACO) Alarm Control Wire-Wrap Connectors (55300A/55310A Only)	page 3-20
– Remote Alarm Control Wire-Wrap Connectors (55300A/55310A Only)	page 3-21
• ALARMS Connector (55300A/55320A/55322A Only)	page 3-22
• RS-232 Serial Interface Ports, Input/Output (I/O)	page 3-24
– REMOTE ACCESS PORT RS-232 Serial Interface Port	page 3-24
– PORT 1 Front-Panel RS-232 Serial Port	page 3-25
– TIME OF DAY Rear-Panel RS-232 Serial Port	page 3-26
• Connecting a Terminal/Computer or Modem	page 3-27
– To Connect the 55300A to a Terminal Via REMOTE ACCESS PORT Serial Port	page 3-28
– To Connect the 55300A to a Modem Via REMOTE ACCESS PORT Serial Port	page 3-28
– To Connect the 55300A to a Terminal Via PORT 1 Serial Port	page 3-29
– To Connect the 55300A to a PC Via TIME OF DAY Serial Port	page 3-30
– To Connect the 55300A to a Palmtop Computer	page 3-31
• Making Your Own RS-232 Cables	page 3-32
• Configuring the RS-232 Port(s)	page 3-33
– If You Need to Make Changes to the Serial Port Settings	page 3-34
– If Changes Have Already Been Made to the Serial Port Settings	page 3-36
– To Restore RS-232 Serial Port Factory-Default Values	page 3-37
• Setting Up Security	page 3-39
– To Enable Security	page 3-39
– To Disable Security	page 3-41
• Operating Concepts	page 3-42
– General	page 3-42
– Holdover Description	page 3-42
– Understanding AIS, Squelched, and Continuous	page 3-43
– Holdover Action of the Telecommunication Outputs	page 3-43
• In Case of a Problem	page 3-45

---

## Inputs



### GPS ANTENNA Input

The N-type (female) **GPS ANTENNA** connector allows you to connect the 58504A or 58513A Antenna Assembly. The antenna assemblies are “active” antennas; a “passive” antenna will not work with the 55300A.

Integral to the antenna assembly is a low noise amplifier (LNA) that is provided for 55300A operation with antenna cable lengths up to 378 feet (115.2 meters) for LMR 400 cables or 175 feet<sup>1</sup> (53.3 meters) for RG-213 cables. The single coax cable is used to provide signals from the antenna to the 55300A and to supply a dc voltage to the LNA. For longer antenna feed runs, an additional amplifier (58509A Antenna Line Amplifier) is required to compensate for lengths greater than 378 feet (115.2 meters) or 175 feet (53.3 meters). An environmental cover that shields the antenna from wind, rain, and snow, and a ground plane that prevents problems with reflected signals is available as the 58510A—or combined in the 58513A.

Refer to Chapter 1, “Getting Started,” in this guide for information on the components of the antenna system and installation instructions.

### *Recommended Antenna Cable Assemblies*

There are two types of cable assemblies that Symmetricom recommends you use to connect your antenna system: LMR 400 or RG-213 (Belden® 8267).

The following paragraphs describes when and how many line amplifiers are required with the LMR 400 and RG-213 cables.

---

<sup>1</sup> One hundred and seventy-five feet includes the sum total of all of the cables used to connect the antenna to the 55300A (such as the cable between the antenna and line amplifier, the cable between the line amplifier and lightning arrester, and the cable between the lightning arrester and the 55300A).

## Inputs

### LMR 400 Cable Line Amplifier Requirements

If cable length between GPS receiver and antenna is:

- Less than 115 meters (377 feet), no line amplifier is necessary.
- More than 115 meters (377 feet) and less than 240 meters (787 feet), you need 1 line amplifier.
- More than 240 meters (787 feet) and less than 360 meters (1181 feet), you need 2 line amplifiers.
- More than 360 meters (1181 feet), contact Symmetricom for assistance.

### RG-213 Cable Line Amplifier Requirements

If cable length between GPS receiver and antenna is:

- Less than 53 meters (174 feet), no line amplifier is necessary.
- More than 53 meters (174 feet) and less than 105 meters (345 feet), you need 1 line amplifier.
- More than 105 meters (345 feet) and less than 158 meters (518 feet), you need 2 line amplifiers.
- More than 158 meters (518 feet), contact Symmetricom for assistance.

### *Antenna Cable Length Delay*

The RG 213 propagation delay is 1.54 nanoseconds per foot (5.05 ns/meter). The LMR 400 propagation delay is 1.2 nanoseconds per foot (3.93  $\mu$ s/meter). Given these delay values per foot you can calculate the delay for your cable length.

Table 3-1A and 3-1B list the delay values that you need to use with the ED-EQPT:::GPS:<ctag>::ADEL= <nanoseconds>; command for the available the cable assemblies.

**Inputs****Table 3-1A. Delay Values for the 58518A/519A and 58518AA/519AA RG-213 Antenna Cables**

<b>Cable Option</b>	<b>Length</b>	<b>RG 213 or Belden 8267 Antenna Delay Value</b>
001	3.3 ft (1m)	5.0 nanoseconds
002	6.7 ft (2 m)	10.3 nanoseconds
005	16.4 ft (5 m)	25.2 nanoseconds
010	32.8 ft (10 m)	50.5 nanoseconds
015	49.2 ft (15 m)	75.7 nanoseconds
030	98.4 ft (30 m)	151.5 nanoseconds
050	164.0 ft (50 m)	252.5 nanoseconds

The nominal delay value is labeled on the cables.

**Table 3-1B. Delay Values for the 58520A/521A and 58520AA/521AA LMR 400 Antenna Cables**

<b>Cable Option</b>	<b>Length</b>	<b>LMR 400 Antenna Delay Value</b>
001	3.3 ft (1m)	3.9 nanoseconds
002	6.7 ft (2 m)	8.0 nanoseconds
005	16.4 ft (5 m)	19.6 nanoseconds
010	32.8 ft (10 m)	39.3 nanoseconds
015	49.2 ft (15 m)	59.0 nanoseconds
030	98.4 ft (30 m)	118.0 nanoseconds
060	196.8 ft (60 m)	236.1 nanoseconds
110	360.8 ft (110 m)	432.9 nanoseconds

The nominal delay value is labeled on the cables.



## Inputs

### POWER A and B –48 VDC Inputs

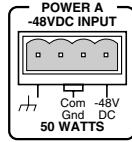

The dual redundant power inputs (A and B) allow you to connect one –48 Vdc as the primary power source (POWER A) and the other as a alternate –48 Vdc source.

The two inputs are truly equal, and power is always drawn from the source of the higher voltage. A region exists where current load is shared when the voltages are equal.

See Figure 1-2A in Chapter 1, “Getting Started,” in this guide for illustration of the dc power connector plug that is used to connect the external –48 Vdc supply.

### ESD Chassis Ground Connection



Front and rear panel jacks allow connection to the chassis ground for an Electrostatic Discharge (ESD) strap.

---

## Telecommunication Frequency Outputs

The 55300A is equipped to handle several telecommunications output options for 1544 kbps and 2048 kbps applications. *The standard telecommunication output signals are 1544 kHz (Output A and B on the 55300A/55310A) or 2048 kHz (2048 kHz outputs on the 55300A/55320A/55322A).*

The following optional telecommunication signals, which are selected when the product is ordered, are available for the 55300A/55310A or 55300A/55320A/55322A:

Options available for the 55300A/55310A:

- Option 104      1544 kbps, DS1 D4 Super Frame)
- Option 105      1544 kbps, DS1 ESF (Extended Super Frame)

Options available for the 55300A/55322A:

- Option 220      2048 kbps, 120 $\Omega$  Balanced, CCS (Common Channel Signaling)
- Option 221      2048 kbps, 120 $\Omega$  Balanced, CAS (Channel Associated Signaling)
- Option 222      2048 kbps, 120 $\Omega$  Balanced, CCS-CRC4 (Cyclic Redundancy Check)

Options available for the 55300A/55320A:

- Option 270      2048 kbps, 75 $\Omega$  Unbalanced, CCS (Common Channel Signaling)
- Option 271      2048 kbps, 75 $\Omega$  Unbalanced, CAS (Channel Associated Signaling)
- Option 272      2048 kbps, 75 $\Omega$  Unbalanced, CCS-CRC4 (Cyclic Redundancy Check)

The following subsections discuss the various 1544 kHz/kbps and 2048 kHz/kbps telecommunication signals provided by the 55300A.

**Telecommunication Frequency Outputs****MONITOR Output**

This output is a 1544 kbps telecommunication signal from the 55300A/55310A unit, or a 2048 kbps telecommunication signal from the 55300A/55320A/55322A unit.

The 55300A/55310A's DS1 (Digital Signal Level 1—1544 kbps) output is a protected test output, which is similar to the rear-panel **DS1** wire-wrap outputs (see following section). The only difference is **MONITOR** signal output level is 18 dB less than **DS1**. This jack is a standard miniature telecommunication phone jack.

The DS1 or 1544 kbps standard interface, which is known as the T1 frequency for US telecommunications.

The 55300A/55320A/55322A's 2048 kbps output meets all of the specifications (i.e., impedance, frequencies, etc.) required for a non-US telecommunications signal. (Refer to paragraph 2, Figure 15/G.703 and Table 6/G.703 of the *Recommendation G.703* standard for details on the 2048 kbps signal.)

The 2048 kbps and E1 terminology are synonymous for the standard interface signal in non-US telecommunications.

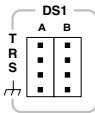
**DS1 Wire-Wrap Connector Outputs (55300/55310A Only)**

**DS1** wire-wrap connector outputs meet all of the specifications (that is, impedance, frequencies, etc.) required for a DS1 telecommunications signal, which is known as the T1 frequency for US telecommunications. (Refer to paragraph 2, Figure 10/G.703 and Table 4/G.703 of the *Recommendation G.703* standard for details on the 1544 kbps signal.)

Either Option 104 or Option 105 (see page 3-8) is provided for these A and B outputs. These outputs are 1544 kbps signals and are squelched at powerup when not locked to GPS. After locking to GPS, the outputs are valid formatted signals. If a user-specified holdover threshold period has been exceeded, these signals will be either the factory default AIS (non-formatted), or squelched, or continuous signals. (Refer to the sections titled “Understanding AIS, Squelched, and Continuous” and “Holdover Action of the Telecommunication Outputs” starting on page 3-43 in this chapter for specifics.)

The customary connector for the DS1 output, in the United States, is wire-wrap. The 55300A provides two sets of wire-wrap outputs from the one DS1 output for the convenience of the operators. Normally, you would use one connection from the DS1 output, but you may want to

**Telecommunication Frequency Outputs**

bridge a second line on to it or you might want to change the distribution system. Thus, the two sets of outputs permits you to hook up the DS1 to the second set of connections before you transfer from the first set of connections without any downtime.

Each parallel row of wire-wrap connector pins has a T (tip), R (ring), S (sleeve), and chassis ground (optional use) connections. The T, R, and S wire-wrap pins allow a shielded, twisted pair connections to a standard three-circuit phone plug. The 1544 kbps signal is across the T (+) and R (return) pins.

The chassis ground pin is available for applications when the sleeve needs to be wired to the shield wire and tied to ground. (This is done by connecting the shield of the twisted pair wire to the chassis ground pin, and then connecting a jumper wire between the chassis ground and S pins.) For applications when the shield wire should not be tied to ground, then the chassis ground pin can be used as a place to hang the shield wire; this way, the shield wire doesn't have to float. If you decide later to connect the shield wire to chassis ground, you can connect a jumper wire between the chassis ground and S pins.

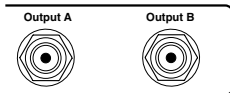
**Output A and B (55300A/55310A Only)**

Output A and B telecom outputs are identical 1544 kHz signals, except the “squelched” signal (Output B) is present only after the 55300A is locked to GPS. The “continuous” signal (Output A) is always present. These telecom outputs are non-formatted waveforms as shown in the following figure.

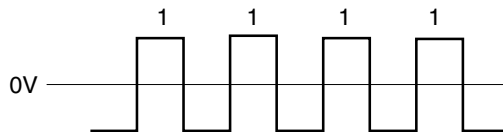

The squelched Output B allows you to disable the square wave telecom output when the 55300A is not locked to GPS. The squelched mode is selected or enabled via the appropriate TL1 command (refer to the sections titled “Understanding AIS, Squelched, and Continuous” and “Holdover Action of the Telecommunication Outputs” starting on page 3-43 in this guide).

The continuous Output A square wave output is always present whether the 55300A is locked or not locked to GPS.

**Telecommunication Frequency Outputs**

These output signals have a maximum peak voltage (A) 1.5V and a minimum peak voltage of 0.75V into 75Ω. The pulse width (B) is 324 ns  $\pm$ 25 ns.

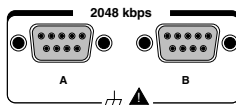
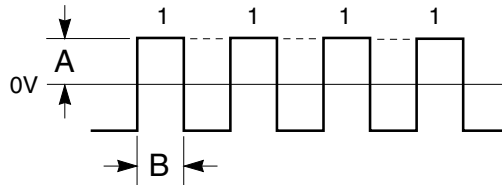
**2048 kbps Outputs (55300A/55320A/55322A Only)**

These Option 200s (2048 kbps; see page 3-8) telecom outputs are provided at the A and B connectors. The 55320A has BNC connectors for these outputs as shown in the adjacent figure. The 55322A has DE-9S Subminiature D connectors.

These 2048 kbps telecom formatted outputs meet all of the specifications (i.e., impedance, frequencies, etc.) required for a non-US (2048 kbps) telecommunications signal. Both A and B outputs are either squelched or AIS; that is, they are in the same state, not one AIS and the other squelched. These formatted outputs are squelched (not present) until the unit is locked to GPS.

The squelched, AIS, or continuous modes can be selected or enabled via the appropriate TL1 command (refer to the sections titled “Understanding AIS, Squelched, and Continuous” and “Holdover Action of the Telecommunication Outputs” starting on page 3-43 in this guide).

The 2048 kbps outputs are formatted. That is, the ones (1) and zeros (0) are part of the waveform as shown in the figure below. (The 2048 kHz outputs, which are discussed starting on page 3-13 are not formatted.)

These formatted telecom outputs, shown below, are characterized by nominally rectangular shape pulses, with rise and fall times less than 1 microsecond. The voltage peak (A) is 2.37V  $\pm$ 0.237V for the 75Ω unbalanced outputs, and 3.0V  $\pm$ 0.3V for the 120Ω balanced outputs. The pulse width (B) is 244 ns  $\pm$ 25 ns.

**Telecommunication Frequency Outputs**

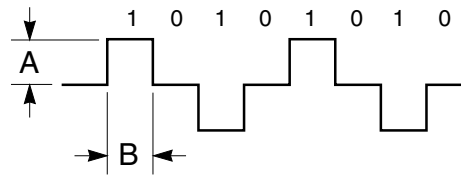

Refer to paragraph 6, Figure 10/G.703 and Table 6/G.703 of the *Recommendation G.703* standard for more information on this signal.

As mentioned previously, the HP 55323A (or equivalent) has DE-9S Subminiature D connectors. The pins used on these connectors are described in Table 3-2.

**Table 3-2. 2048 kbps Balanced Output Pin Assignments**

*Pin Number	Input/Output	Description
1		Chassis ground
2	Output	Differential output
3		Chassis ground
5		Center tap of output transformer
6	Output	Differential output
7		Chassis ground

\* All other pins are not connected.

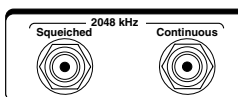
**Telecommunication Frequency Outputs****2048 kHz Outputs (55300A/55320A/55322A Only)**

Two types of 2048 kHz square wave telecom outputs, “squelched” and “continuous,” are provided from a pair of BNC connectors. These telecom outputs are non-formatted waveforms as shown in the following figure.

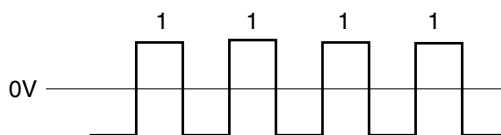
***Squelched***

The squelched feature allows you to disable the 2048 kHz square wave telecom output when the 55300A is not locked to GPS. Other than squelched, the squelched telecom output is the same as the continuous telecom output. The squelched mode is selected or enabled via the appropriate TL1 command (refer to the sections titled “Understanding AIS, Squelched, and Continuous” and “Holdover Action of the Telecommunication Outputs” starting on page 3-43 in this guide).

***Continuous***

The continuous 2048 kHz telecom output is always present whether the 55300A is locked or not locked to GPS. This square wave telecom output, shown in the following figure, has a maximum peak voltage (A) 1.5V and a minimum peak voltage of 0.75V into 75Ω. The pulse width (B) is 244 ns  $\pm$ 25 ns.

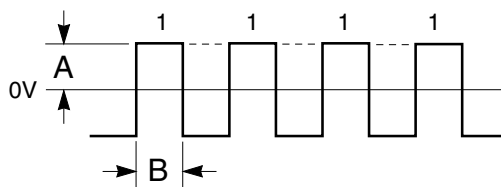

---

## Time and Frequency Outputs



### 10 MHz Output

This is a 10 MHz output reference signal traceable to UTC (USNO) that you can use as a high accuracy frequency “house standard” for calibration or development needs.

### 1 PPS (One Pulse Per Second) Output

This a highly accurate 1 PPS time standard output that can be used for user-specific synchronization applications.

In the GPS locked mode, the 55300A outputs a 1 PPS signal derived from the internal oscillator, which is locked and traceable back to Coordinated Universal Time (UTC) as determined by GPS. In the absence of GPS, the 1 PPS signal will continue with the internal reference oscillator being adjusted by SmartClock™ technology (holdover mode). In the holdover mode, the timing 1 PPS accuracy will degrade as the holdover time increases.

### IRIG-B Output

The IRIG-B formatted time code signal, which is only present after the 55300A locks to GPS, may be used for general purpose time distribution, and magnetic tape annotation applications requiring time of year.

IRIG-B is a one-frame-per-second signal indicating the date and exact time. The output contains both a BCD-coding of day, hour, minute, second, and a binary coding of accumulated seconds since midnight. An example is shown in Figure 3-1. The modulated code uses a 1 kHz carrier.

The sample IRIG-B output shown in Figure 3-1 consists of time-coded pulses that indicate the time as:

*173 days into the year,  
21 hours into the day,  
18 minutes into the hour, and  
42 seconds into the minute.*

The sample IRIG-B BCD output in Figure 3-1 also includes a Straight Binary portion, which consists of time-coded pulses that indicate the time of day as 76,722 seconds into the day, which is the total you would get if you summed up 21 hours, 18 minutes, and 42 seconds.



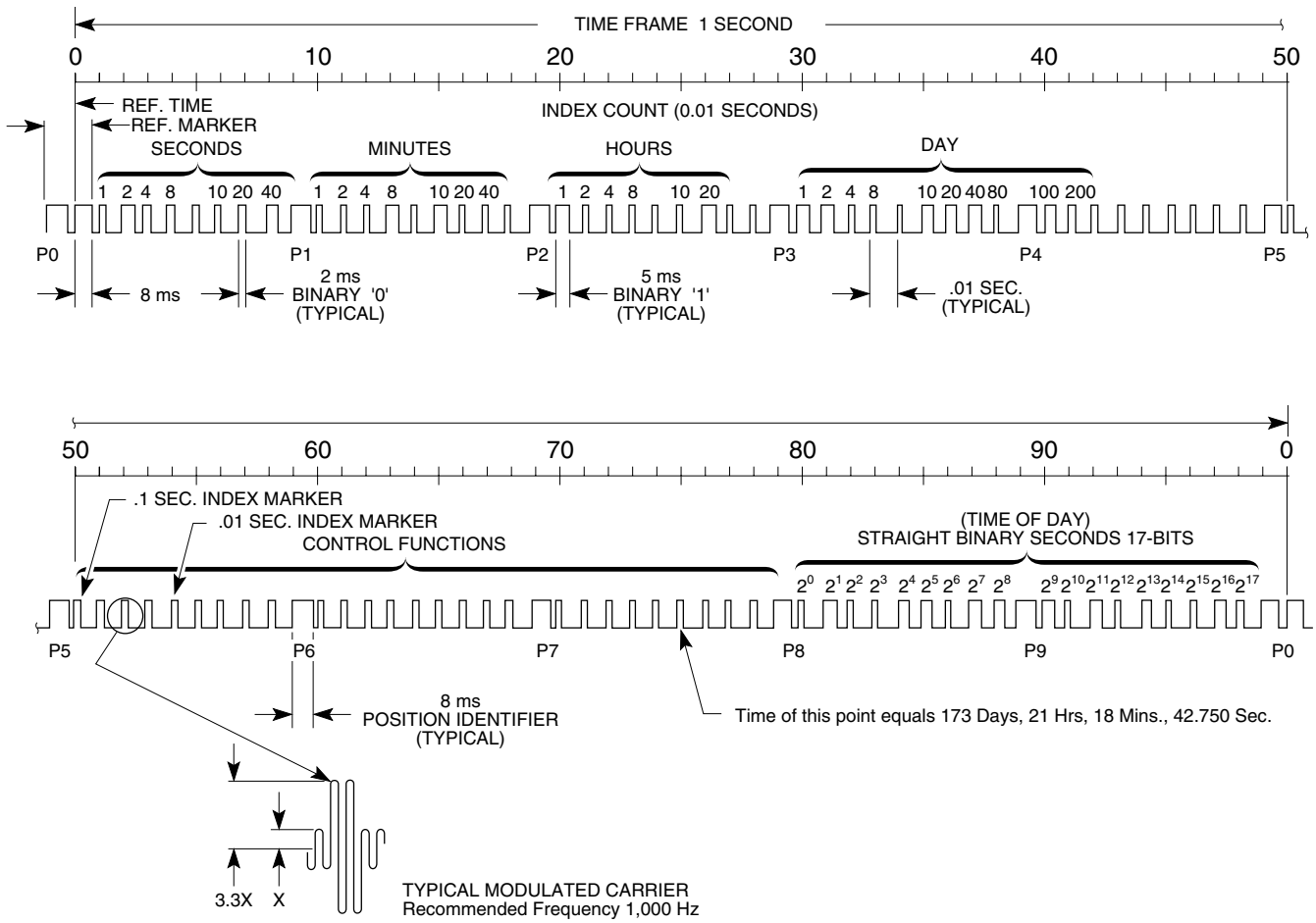

**Figure 3-1. Sample IRIG-B Output Signal**

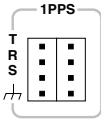
**Time and Frequency Outputs****1 PPS Wire-Wrap Connector Outputs  
(55300/55310A Only)**

These wire-wrap connector outputs provide two sets of wire-wrap outputs from one 1 PPS output for the convenience of the operators. Normally, you would use one connection from the 1 PPS output, but you may want to bridge a second line on to it or you might want to change the distribution system. Thus, the two sets of outputs permits you to hook up the 1 PPS to the second set of connections before you transfer from the first set of connections without any downtime.

Each parallel row of wire-wrap connector pins has a T (tip), R (ring), S (sleeve), and chassis ground (optional use) connections. The T, R, and S wire-wrap pins allow a shielded, twisted pair connections to a standard three-circuit phone plug. The 1 PPS signal is across the T (+) and R (return) pins, and is a RS-422 differential pair signal. The amplitude of this signal is greater than 2.0V into a 100Ω load, pulse width is 25 microsecond, and time interval is 1 second.

The chassis ground pin is available for applications when the sleeve needs to be wired to the shield wire and tied to ground. (This is done by connecting the shield of the twisted pair wire to the chassis ground pin, and then connecting a jumper wire between the chassis ground and S pins.) For applications when the shield wire should not be tied to ground, then the chassis ground pin can be used as a place to hang the shield wire; this way, the shield wire doesn't have to float. If the you decide later to connect the shield wire to chassis ground, you can connect a jumper wire between the chassis ground and the S pins.

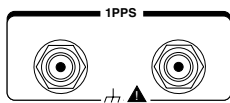
**1 PPS Negative and Positive Outputs  
(55300A/55320A/55322A Only)*****1 PPS BNC Outputs (55300A/55320A Only)***

These 1 PPS output signals are RS-422 signals, and are supplied between pairs. The both of these 1 PPS output signals are the same highly accurate 1 PPS time standard output that can be used for user-specific synchronization applications; however, one is a positive 1 PPS signal and the other is a negative 1 PPS signal as shown in the following figure. The BNC to the left is the positive 1 PPS output.

The amplitude (A) is greater than 2.0V into a 100Ω load. The pulse width (B) is 26 microsecond. The time interval is 1 second.

**Time and Frequency Outputs**

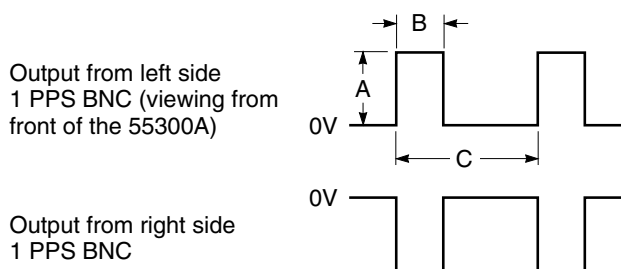

**1 PPS Pair of DE-9S Subminiature D Connector Outputs (55300/55322A Only)**

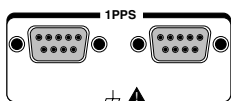

This pair of 9-pin female connectors provide parallel 1 PPS output signals, which are RS-422 signals. Each connector provides two independent 1 PPS signals, which are a differential pair with the center tap grounded to the chassis by the shield for a balanced pair. Both of these 1 PPS output signals are the same highly accurate 1 PPS time standard output that can be used for user-specific synchronization applications; however, one is a positive 1 PPS signal and the other is a negative 1 PPS signal as shown in the following figure.

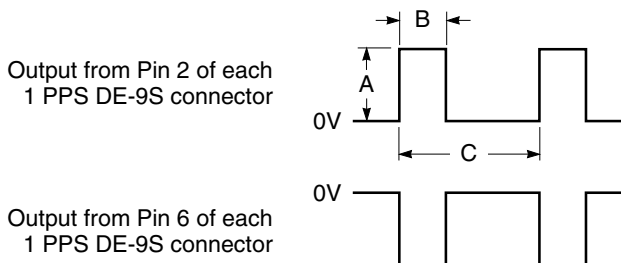

The amplitude (A) is greater than 2.0V into a 100Ω load. The pulse width (B) is 26 microsecond. The time interval is 1 second.

The pins used are described in Table 3-3.

**Table 3-3. Pin Assignments for Each of the 1 PPS DE-9S Connectors**

*Pin Number	Input/Output	Description
1		Chassis ground
2	Output	Positive Pulse
3		Chassis ground
6	Output	Negative Pulse
7		Chassis ground

\* All other pins are not connected.

---

## Indicators

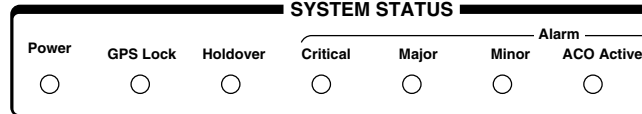

### Power Indicator

This indicator lights when the input power is supplied to the 55300A.

### GPS Lock Indicator

This indicator lights when the 55300A is tracking satellites and has phase-locked its internal reference to reference time derived from satellite data. This indicator will go off whenever the above condition isn't met, which would typically occur when satellite tracking is lost or while the 55300A is powering up.

### Holdover Indicator

This indicator lights to show that GPS lock has been lost and the 55300A is in holdover (or bridging<sup>2</sup>) mode. It only lights if the 55300A has been locked once; it will never light until the 55300A has been locked once. While in holdover, the internal reference oscillator will be adjusted by the SmartClock™ technology.

---

<sup>2</sup> Holdover is referred in GR-2830-CORE (Bellcore Standard for Reference Clocks) as bridging.

## Indicators

---

**NOTE**

---

If the Holdover indicator lights before the 55300A has been locked for 24 hours, then the 55300A has not had sufficient time to learn the characteristics of the internal reference oscillator. In this case, the specification for Timing Accuracy during holdover may not be met. This specification applies only after the 55300A has had sufficient stable operation time.

### **Critical Alarm Indicator**

---

**NOTE**

---

Alarm causes and their severity are configurable. See Table 3-4A on page 3-22 for alarms default listings.

This alarm indicator lights to show the presence of a Critical alarm. The actual alarm cause is electronically transmitted using the REPT-ALARM message. In addition, it may be read using the RTRV-ALRM command. Refer to the programming guide for more information.

### **Major Alarm Indicator**

This alarm indicator lights to show the presence of a Major alarm. The actual alarm cause is electronically transmitted using the REPT-ALARM message. In addition, it may be read using the RTRV-ALRM command. Refer to the programming guide for more information.

### **Minor Alarm Indicator**

This alarm indicator lights to show the presence of a Minor alarm. The actual alarm cause is electronically transmitted using the REPT-ALARM message. In addition, it may be read using the RTRV-ALRM command. Refer to the programming guide for more information.

### **ACO Active Indicator**

This indicator lights when the alarm cutoff is active.

## Controls

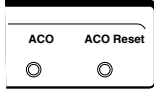

### ACO Pushbutton Control

The **ACO** (alarm cutoff) is a non-locking pushbutton switch that, when pushed, *silences* the audible, local external alarms without turning off the alarm LED indicator.

### ACO Reset Pushbutton Control

The **ACO Reset** is a non-locking pushbutton switch that, when pushed, *resets* ACO. The **ACO Active** LED indicator is turned off if the alarm LED indicators are turned off.

### Local (with ACO) Alarm Control Wire-Wrap Connectors (55300A/55310A Only)

The **Local (with ACO)** wire-wrap connectors, shown in Figure 3-2, provide three independent alarm contacts or relays for the critical, major, and minor alarms.

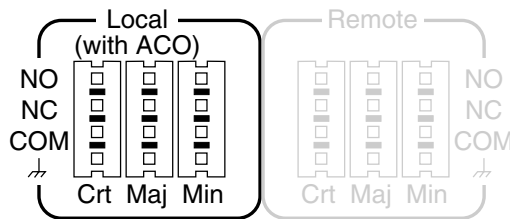

**Figure 3-2. Local (with ACO) Alarm Wire-Wrap Connectors**

The local external (audible) alarms can be cutoff or can be caused to not operate. For example, say you have a major alarm indication that is driving a buzzer, and you are trying to work to solve the alarm problem. You can push the front-panel **ACO** button to turn off the buzzer (the local alarm). (The remote alarm indication, however, which is located on a board in the control room, will indicate that the major alarm condition still exists.)

Figure 3-3 shows a local alarm wire-wrap connector and a demonstrative relay circuit that drives or controls the wire-wrap NC and NO pins via firmware. In “normal” operation, S1 is closed. Loss of power is an “alarm” condition; thus, S1 is opened.

**Controls**

Four wire-wrap pins are provided for each alarm (i.e., critical, major, and minor) as shown in Figure 3-3:

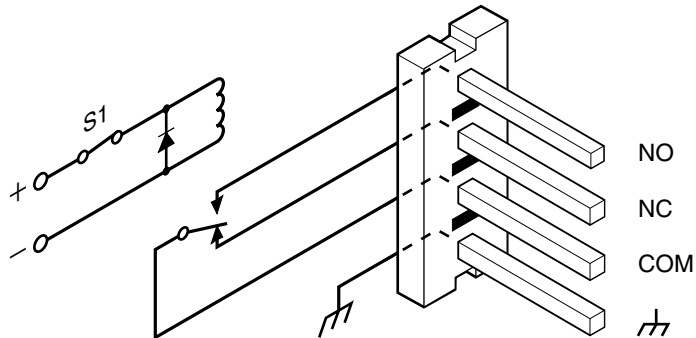

**Figure 3-3. The Local/Remote Demonstrative Relay Circuit**

- **NO** (normally-opened contact) relay contact or wire-wrap pin—NO contact is opened when there is no alarm, and is closed on alarm.
- **NC** (normally-closed contact) relay contact or wire-wrap pin—NC contact is closed when there is no alarm, and is opened on alarm.
- **COM** (common)
-  chassis ground—provided in case you need it.

It's your choice on how you want to wire your alarm system to run (that is, using the normally-closed or normally-opened logic). The 55300A provide this flexibility so that the 55300A can be compatible with any current operating system.

### **Remote Alarm Control Wire-Wrap Connectors (55300A/55310A Only)**

The **Remote** wire-wrap connectors, shown in Figure 3-4, provide three independent alarm contacts or relays for the critical, major, and minor alarms.

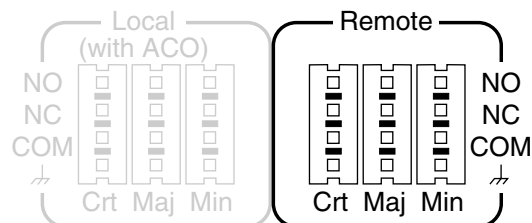

**Figure 3-4. Remote Alarm Wire-Wrap Connectors**

**ALARMS Connector (55300A/55320A/55322A Only)**

The remote alarm can be wired to an external visual alarm located in a remote control room. This way, the operator can easily detect when an alarm condition exists.

---

## ALARMS Connector (55300A/55320A/55322A Only)

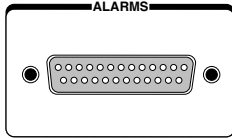

This 25-pin male subminiature D (DB-25P) connector (**ALARMS**), located on the top panel, provides six independent alarm relays for the Critical, Major, and Minor alarms for both remote (visual) and local (audible) alarm systems. Local (audible) alarm relays may be turned off with “ACO” (Alarm Cutoff) button on the front panel.

Alarm causes are configurable (refer to the programming guide for specifics). Typical causes can be from Loss of GPS signal (holdover), Output Failure, Oscillator Failure, or Power Failure. Alarm causes and their severity are configurable. Table 3-4A lists the defaults.

**Table 3-4A. Alarm Defaults**

Type of Failure	Result
Hardware	Always causes a Major alarm.
Power	Causes all three alarms (Minor, Major, Critical).
Loss of GPS for 30 minutes	Causes a Minor alarm.
Loss of GPS for 24 hours and Holdover action	Causes a Major alarm.

The pins used are described in Table 3-4B.



**ALARMS Connector (55300A/55320A/55322A Only)****Table 3-4B. ALARMS Connector Pin Assignments  
(55300A/55320A Only)**

*Pin Number	Description
2	Minor Alarm Audible—opened on alarm
3	Minor Alarm Audible—common
4	Minor Alarm Visual—opened on alarm
5	Minor Alarm Visual—common
6	Major Alarm Audible—opened on alarm
7	Major Alarm Audible—common
8	Major Alarm Visual—opened on alarm
9	Major Alarm Visual—common
10	Critical Alarm Audible—opened on alarm
11	Critical Alarm Audible—common
12	Critical Alarm Visual—opened on alarm
13	Critical Alarm Visual—common
14	GND (Ground)
15	Minor Alarm Audible—closed on alarm
17	Minor Alarm Visual—closed on alarm
19	Major Alarm Audible—closed on alarm
21	Major Alarm Visual—closed on alarm
23	Critical Alarm Audible—closed on alarm
25	Critical Alarm Visual—closed on alarm

\* All other pins are not connected.

---

## RS-232 Serial Interface Ports, Input/Output (I/O)

The 55300A has separate rear or top front panel (**REMOTE ACCESS PORT**) and front-panel (**PORT 1**) RS-232 serial interface ports. The operation and configuration of these ports are described in the following paragraphs. More information is provided in the sections titled “Connecting a Terminal/Computer or Modem” and “Configuring the RS-232 Port(s)” in this chapter on pages 3-27 and 3-33, respectively.

### REMOTE ACCESS PORT RS-232 Serial Interface Port

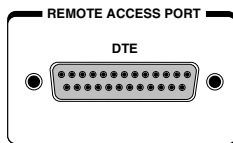

This 25-pin female subminiature D (DB-25S) connector (**REMOTE ACCESS PORT**), located on the rear panel or top front is a DTE configuration serial interface port at 9.6kbps (default). The communication language for this port is TL1 (Transaction Language1).

*This port is intended to be connected to the remote management system of the Central Office.*

This port allows full control of the 55300A. This can be done by connecting any terminal or computer with an RS-232 serial interface and suitable terminal emulation software, then sending the correct commands for transmitting or retrieving data. The primary port allows you to customize the 55300A on installation, to change the 55300A's operating characteristics, to retrieve its state information, to clear stored data.

The pins used are described in Table 3-5.

**RS-232 Serial Interface Ports, Input/Output (I/O)****Table 3-5. REMOTE ACCESS PORT RS-232 Serial Port Pin Assignments**

*Pin Number	Input/Output	Description
2	Output	Transmit Data (TxD). 55300A output.
3	Input	Receive Data (RxD). 55300A input.
4	Output	Request to Send (RTS). 55300A output.
5	Input	Clear to Send (CTS). 55300A input.
6	Input	Data Set Ready (DSR). 55300A input.
7		Signal Ground (SG), common return.
8	Input	Receive Line Signal Detector ( DCD). 55300A input.
20	Output	Data Terminal Ready (DTR). 55300A output.
22	Input	Ring Indicator (RI). 55300A input.

\* All other pins are not connected. The minimum required connections are pins 2, 3, 7.

Refer to the sections titled “Connecting a Terminal/Computer or Modem” in this chapter, on page 3-27, for wiring diagrams and more information on the RS-232 interface cables.

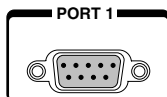
**PORT 1 Front-Panel RS-232 Serial Port**

This 9-pin female subminiature D (DE-9S) connector (**PORT 1**), located on the front panel is a DCE configuration serial interface. The communication language for this port is TL1 (Transaction Language1). This is the local port, which allows you to retrieve information from the 55300A. This can be done by connecting any terminal or computer with an RS-232 serial interface and suitable terminal emulation software, then sending the correct commands for retrieving data.

*This port is intended for use by maintenance crafts person when installing or monitoring the unit.*

**RS-232 Serial Interface Ports, Input/Output (I/O)**

The pins used are described in Table 3-6.

**Table 3-6. PORT1 Front-Panel RS-232 Serial Port Pin Assignments**

*Pin Number	Input/Output	Description
2	Input	Receive (RxD). 55300A input.
3	Output	Transmit Data (TxD). 55300A output.
4	Input	Data Terminal Ready (DTR). 55300A input.
5		Signal Ground (SG), common return.
6	Output	Data Set Ready (DSR). 55300A output.
7	Input	Request to Send (RTS). 55300A input.
8	Output	Clear to Send (CTS). 55300A output.
9	Output	Ring Indicator (RI). 55300A output.

\* All other pins are not connected. The minimum required connections are pins 2, 3, 5.

Refer to the sections titled “Connecting a Terminal/Computer or Modem” in this chapter, on page 3-27, for wiring diagrams and more information on the RS-232 interface cables.

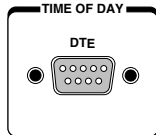
**TIME OF DAY Rear-Panel RS-232 Serial Port**

This 9-pin male subminiature D (DE-9P) connector (**TIME OF DAY**), located on the rear panel, is a RS-232 DTE configuration serial interface port. Its communication language is SCPI (Standard Commands for Programmable Instruments). Time of Day data and a 1 PPS (accurate to UTC) signal are provided on this port. This 1 PPS signal is a RS-232 level signal.

*This port intended use is for connection to a computer for network time protocol (such as one operating an HP AcceSS7 [or equivalent] system).*

The pins used are described in Table 3-7.

**Connecting a Terminal/Computer or Modem****Table 3-7. TIME OF DAY Rear-Panel RS-232 Serial Port Pin Assignments**

*Pin Number	Input/Output	Description
1	Output	1 PPS signal output.
2	Input	Receive Data (RxD). 55300A input.
3	Output	Transmit Data (TxD). 55300A output.
5		Signal Ground (SG), common return.

\* All other pins are not connected.

Refer to the sections titled “Connecting a Terminal/Computer or Modem” in this chapter, on page 3-27, for wiring diagrams and more information on the RS-232 interface cables.

## Connecting a Terminal/Computer or Modem

To connect the 55300A to a computer or modem, you must have the proper interface cable. Most computers are DTE (Data Terminal Equipment) devices. Since the 55300A is mostly a DTE device, you must use a DTE-to-DTE interface cable when connecting to a computer. These cables are also called “null-modem” cables. Only the front-panel **PORT 1** connector of the 55300A is DCE (Digital Communications Equipment). The other two ports (**REMOTE ACCESS PORT** and **TIME OF DAY** are DTE.)

Most modems are DCE (Digital Communication Equipment) devices; thus, you must use a DTE-to-DCE interface cable if connecting the 55300A to a modem.

The interface cable must also have the proper connector on each end and the internal wiring must be correct. Connectors typically have 9pins (DE-9 connector) or 25pins (DB-25 connector) with a “male” or “female” pin configuration. A male (m) connector has pins inside the connector shell and a female (f) connector has holes inside the connector shell.

**To simplify interface cable selections, the following sections tell you which cables to use.**

**Connecting a Terminal/Computer or Modem**

**To Connect the 55300A to a Terminal Via REMOTE ACCESS PORT Serial Port**

Use an HP 24542G (or equivalent) interface cable to connect the 55300A's rear-panel **REMOTE ACCESS PORT** DB-25 female connector to a terminal as shown in Figure 3-5.

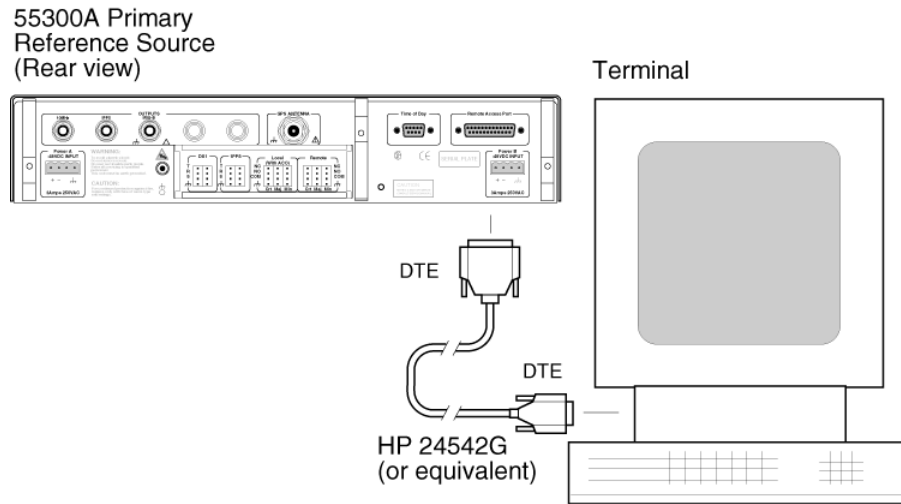
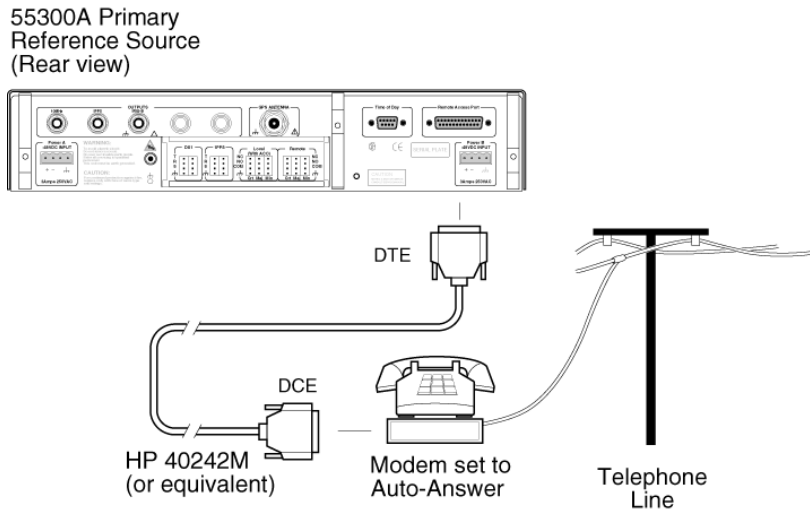

**Figure 3-5. Connecting the 55300A to a Terminal via REMOTE ACCESS PORT**

**To Connect the 55300A to a Modem Via REMOTE ACCESS PORT Serial Port**

Use an HP 40242M (or equivalent) interface cable to connect the 55300A's rear-panel **REMOTE ACCESS PORT** DB-25 female connector to a modem, which is a DCE (Digital Communication Equipment) device, as shown in Figure 3-6.

Chapter 3 Features and Functions  
Connecting a Terminal/Computer or Modem



**Figure 3-6. Connecting the 55300A to a Modem via REMOTE ACCESS PORT**

**To Connect the 55300A to a Terminal Via PORT 1 Serial Port**

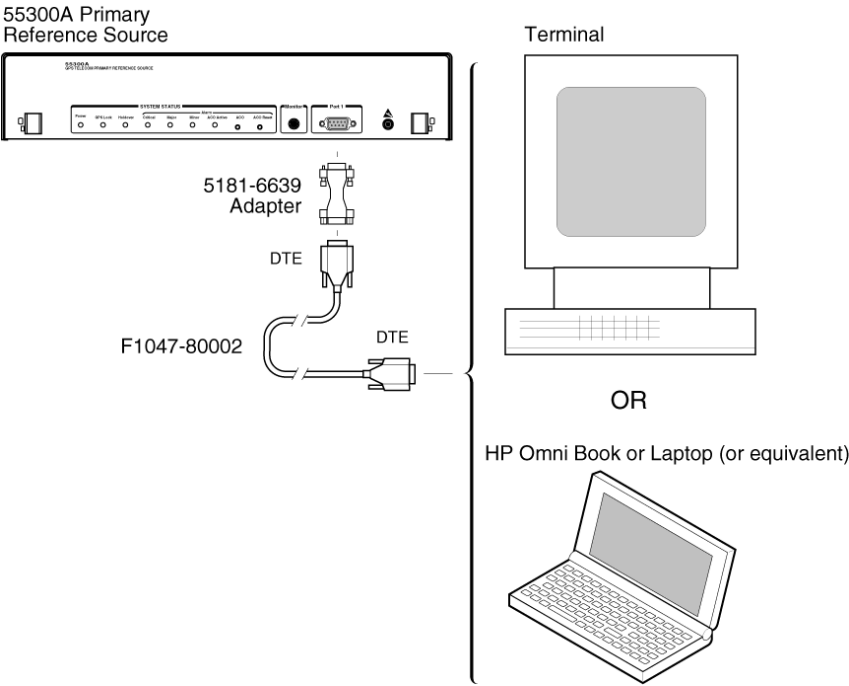

**Figure 3-7. Connecting the 55300A to a Terminal via PORT 1**

**Connecting a Terminal/Computer or Modem**

**To Connect the 55300A to a PC Via TIME OF DAY  
Serial Port**

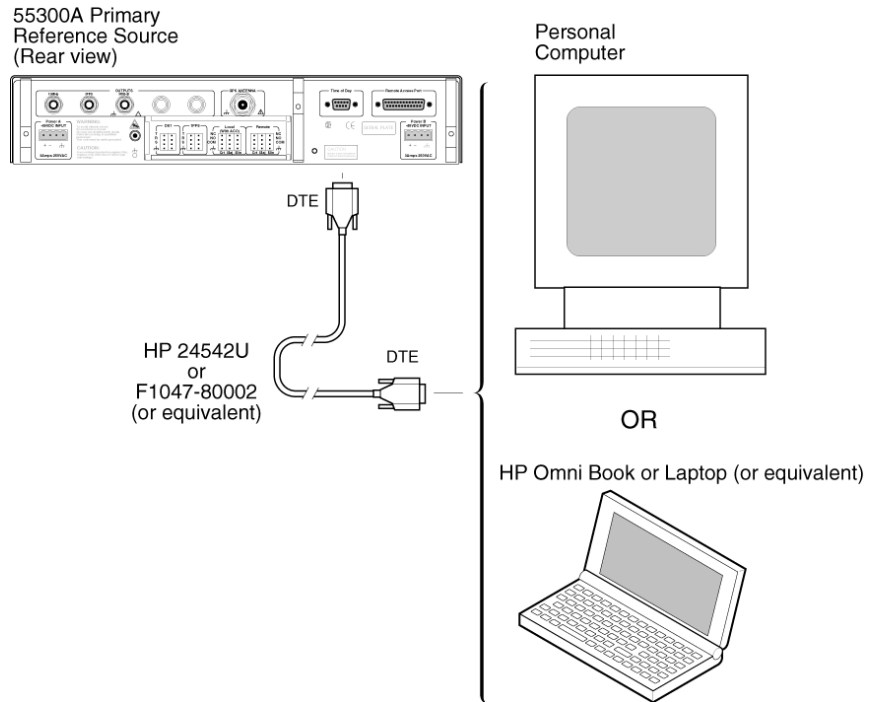

**Figure 3-8. Connecting the 55300A to a PC via TIME OF DAY Port**



**Connecting a Terminal/Computer or Modem**

**To Connect the 55300A to a Palmtop Computer**

***Connecting to the TIME OF DAY Port***

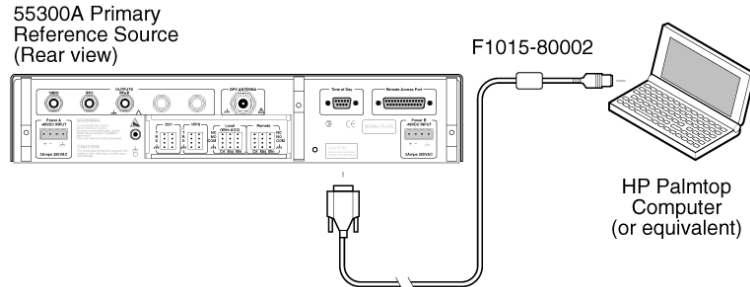

**Figure 3-9A. Connecting the 55300A to a Palmtop via the TIME OF DAY Port**

***Connecting to the REMOTE ACCESS PORT***

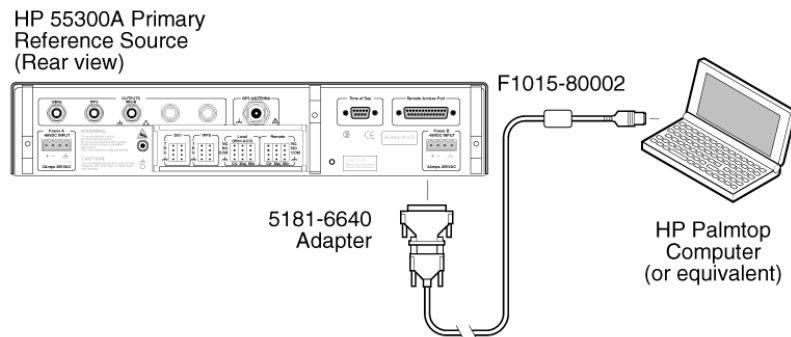
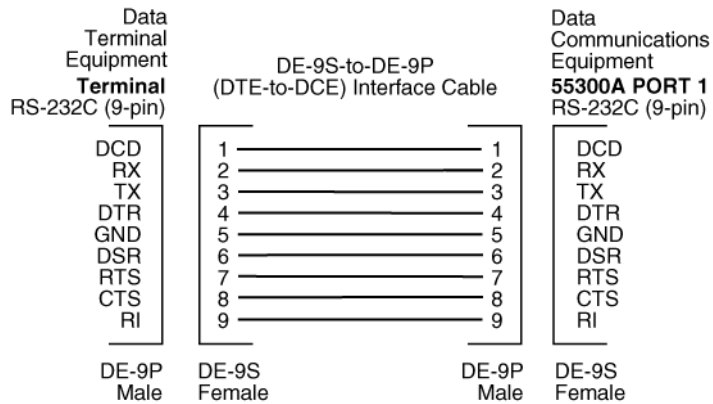

**Figure 3-9B. Connecting the 55300A to a Palmtop via the REMOTE ACCESS PORT**

## Making Your Own RS-232 Cables

If you choose to make your own cable, see figures 3-10 and 3-12.

Figure 3-10 illustrates how to make a DE-9S-to-DE-9P, DTE-to-DCE interface cable that can replace the cable and adapter combination of the HP F1047-80002 (or equivalent) cable and the HP 5181-6639 (or equivalent) adapter for use with **PORT 1**.



**Figure 3-10. DE-9S-to-DE-9P (DTE-to-DCE) Serial interface Connection for PORT 1**

Figure 3-11 illustrates how to make a DE-9S-to-DE-9S, DTE-to-DTE interface cable that can replace the HP F1047-80002 (or equivalent) cable for use with **TIME OF DAY** port.

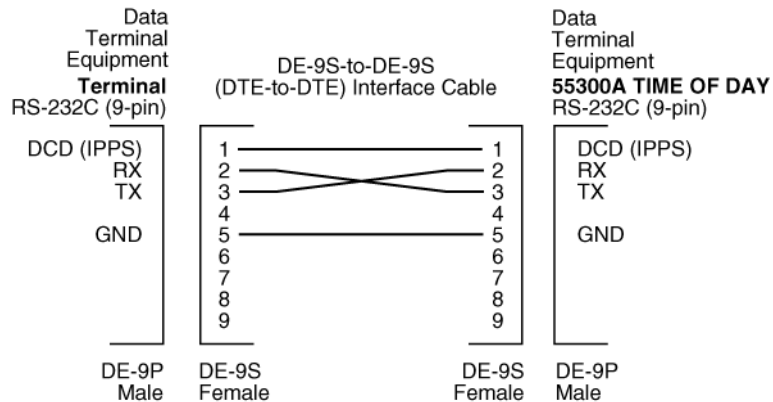

**Figure 3-11. DB-9S-to-DB-9S (DTE-to-DTE) Serial Connection for TIME OF DAY Port**

**Configuring the RS-232 Port(s)**

Figure 3-12 illustrates how to make a DE-9S-to-DB-25P, DTE-to-DTE interface cable that can replace the HP 24542G (or equivalent) interface cable (9-pin female to 25-pin male connectors) for use with **REMOTE ACCESS PORT**.

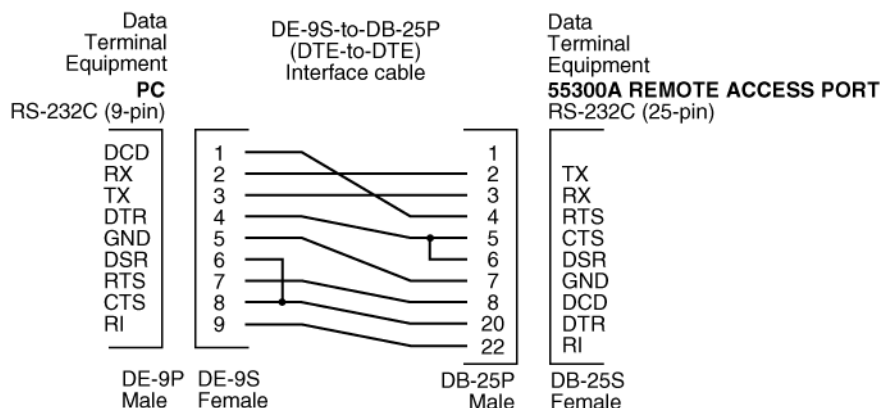

**Figure 3-12. DE-9S-to-DB-25P (DTE-to-DTE) Serial interface Connection**

---

## Configuring the RS-232 Port(s)

The 55300A has one front-panel RS-232 serial interface port (**PORT 1—Local**), and two rear-panel or top front RS-232 serial interface ports (**REMOTE ACCESS PORT** and **TIME OF DAY**).

Software pacing, baud rate, parity, data bits, and stop bits parameters for each port are either user-selectable or fixed and independent of the configuration of the other port.

Tables 3-8 and 3-9 list the configuration factory-default values for **REMOTE ACCESS PORT** and **PORT1**, and **TIME OF DAY**, respectively.

---

### **NOTE**

Security Switch (S1) on the 55300A module's main board can be used to restore all serial-port parameter settings to factory-default values. See the section titled "To Restore RS-232 Serial Port Factory-Default Values" on page 3-37 of this chapter for instructions.

---

**Configuring the RS-232 Port(s)****Table 3-8. REMOTE ACCESS PORT and PORT 1 Configuration Factory-Default Values**

Parameter	Default	Possible Choices
Software Pacing	NONE	FIXED
Baud Rate	9600	1200, 2400, 9600, or 19200
Parity	NONE	FIXED
Data Bits	8	8 (FIXED)
Stop Bits	1	1 (FIXED)
Local Echo	OFF	ON or OFF
Hardware Flow	NONE	NONE or HW

**Table 3-9. TIME OF DAY Port Configuration Factory-Default Values**

Parameter	Default	Possible Choices
Software Pacing	NONE	XON or NONE
Baud Rate	9600	1200, 2400, 9600, or 19200
Parity	NONE	EVEN, ODD, or NONE
Data Bits	8	7 or 8
Stop Bits	1	1 or 2
Full Duplex	ON	ON or OFF

Procedures for configuring the RS-232 ports are provided in the following paragraphs.

### **If You Need to Make Changes to the Serial Port Settings**

---

**CAUTION**

*If you change the serial port settings, your changes will be stored in the 55300A. Cycling power (by disconnecting and reconnecting the external –48Vdc supply) will not reset to factory defaults. Therefore, if you make a change, it is recommended that you record the settings and keep the record with the 55300A.*

*If you need to change the serial port settings, for example, to set up for a different computer, use the guidelines given in this section.*

Serial port settings are changed by issuing ED-EQPT commands for the **REMOTE ACCESS PORT** and **PORT1** ports.

**Configuring the RS-232 Port(s)**

Serial port settings are changed by issuing SYST:COMM:SER commands for the **TIME OF DAY** port.

It is recommended that you issue a single compound command, which simultaneously sets all the serial port parameters. Then connect the other computer and begin using the instrument with the new settings.

**NOTE**

If you choose to set parameters one at a time, you will make the procedure more difficult. That is, with each change, the instrument will be updated, but your terminal or PC will retain its original settings. At each step, you will have stopped serial communications and be forced to modify your terminal or PC settings to match 55300A in order to continue. It is recommended that you make all changes in a single compound command, verify the changes, and record all parameters.

***Configuring REMOTE ACCESS PORT***

Complete configuration of **REMOTE ACCESS PORT** requires that you set *three* parameters. The command line sent in the following example would set the RS-232 baud rate to 2400, set system to not echo commands that you type onto the screen of the remote terminal, and set pacing to hardware.

```
ED-EQPT::GPS:<CTAG>:::RMTBAUD=2400, RMTECHO=ON,
RMTFLOW=HARDWARE;
```

***Configuring PORT 1***

Complete configuration of **PORT 1** requires that you set *three* parameters. The command line sent in the following example would set the RS-232 port baud rate to 2400, set system to not echo commands that you type onto the screen of the local terminal, and set pacing to hardware.

```
ED-EQPT::GPS:<CTAG>:::LCLBAUD=2400, LCLECHO=N,
LCLFLOW=HARDWARE;
```

***Configuring TIME OF DAY Port***

Complete configuration of **TIME OF DAY** port requires that you set *three* parameters. The command line sent in the following example would set the RS-232 port pacing to XON, baud rate to 2400, and parity to EVEN.

```
:SYST:COMM:SER:PACE XON; BAUD 2400; PARITY EVEN
```

## Configuring the RS-232 Port(s)

### If Changes Have Already Been Made to the Serial Port Settings

If you connect your terminal or PC to **PORT 1** or **REMOTE ACCESS PORT**, press Return or Enter, and do not get a “;”(semicolon) prompt back from the 55300A, your 55300A’s serial communication settings for these ports may have been modified.

OR

If you connect your terminal or PC to the **TIME OF DAY** port, press Return, and do not get a **scpi>** or **E-xxx** prompt back from the 55300A, your 55300A’s serial communication settings for this port may have been modified.

This is what you can do:

- Systematically step through the data communication settings on your terminal or PC until your terminal or PC matches the 55300A. The 55300A cannot communicate its settings until this process is complete.

---

**NOTE**

---

Security Switch (S1) on the 55300A module’s main board can be used to restore all serial-port parameter settings to factory-default values. See the section titled “To Restore RS-232 Serial Port Factory-Default Values” on page 3-37 of this chapter for instructions.

- Iterate until you are able to verify that settings on your terminal or PC match the 55300A.

Once you establish communications with one of the TL1 ports (**PORT 1** or **REMOTE ACCESS PORT**), you can send the ED-EQPT command to the 55300A for settings of the other port.

Once you establish communications with the **TIME OF DAY** port, you can send the following queries to verify a complete communication match:

```
SYST:COMM:SER:PACE?  
SYST:COMM:SER:BAUD?  
SYST:COMM:SER:PARITY?  
SYST:COMM:SER:BITS?  
SYST:COMM:SER:SBITS?
```

**Configuring the RS-232 Port(s)**

**To Restore RS-232 Serial Port Factory-Default Values**

Security Switch (S1) on the 55300A module's main board can be used to restore all serial-port communication settings to their factory-default values.

- 1 To restore the 55300A's serial ports to their factory-default values, access S1 as shown in Figure 3-13.

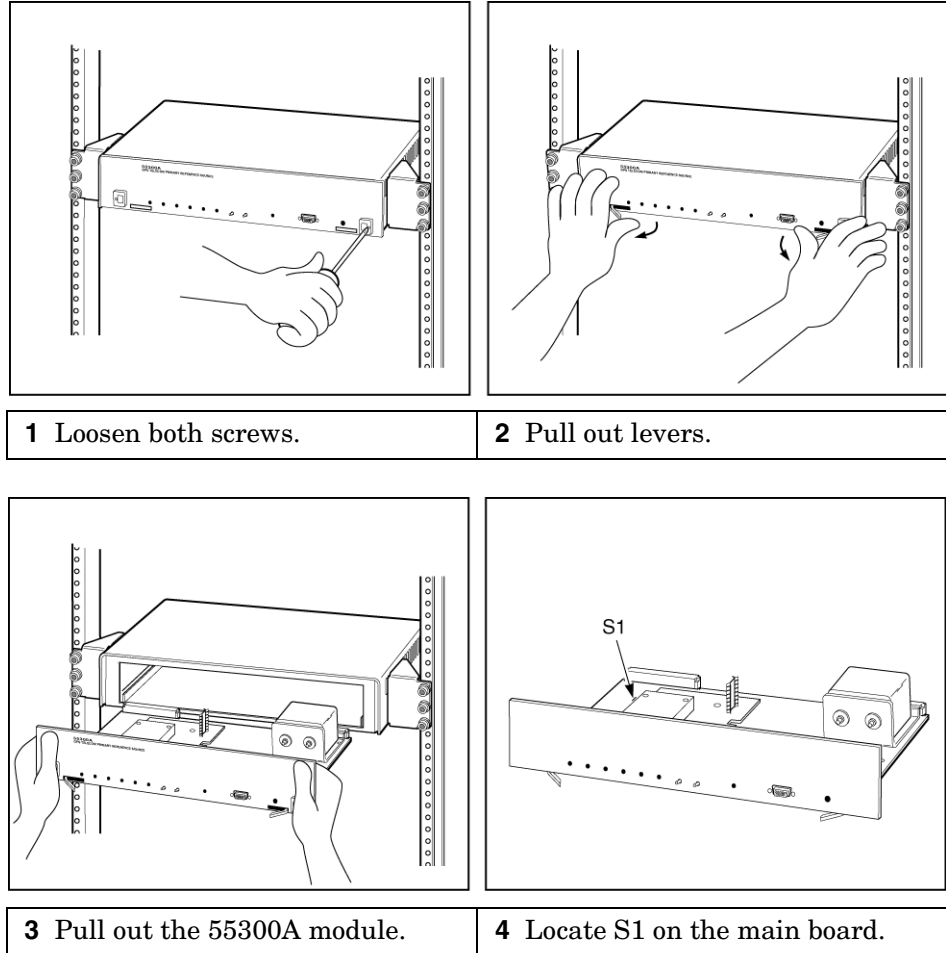

**Figure 3-13. Accessing Security Switch S1**

- 2 Set bit switch B1 on S1 to its ON (Preset All Serial Ports at Powerup) position as shown in Figure 3-14.

**Configuring the RS-232 Port(s)**

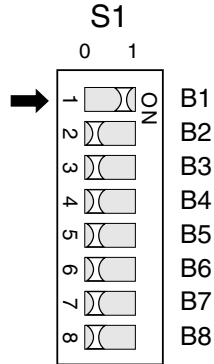

**B1 (Bit1)** Preset All Serial Ports at Powerup

**B2 (Bit2)** Password Required = ON; No Password Required = OFF

**Figure 3-14. Settings for S1 to Restore Factory Default Values for All Three RS-232 Serial Ports.**

- 3 Re-install the 55300A module into the rack mount shelf, and power up the 55300A.

***Note:** This switch setting causes the 55300A to revert back to factory-default values each time you power up. If this is undesirable, then perform the following steps 4 through 6.*

- 4 Remove the 55300A module from its rack mount shelf as shown in Figure 3-13 to access S1.
- 5 Set bit switch B1 on S1 back to its OFF position.
- 6 Re-install the 55300A module into the rack mount shelf, power up the 55300A, resume operation.



## Setting Up Security

When shipped from the factory, the 55300A comes with the security feature disabled. If it is important to protect your 55300A's resources and information from unauthorized users, you need to enable the security feature to set up system security. Table 3-10 lists the two security levels available: PUBLIC (No password required; no security) and SECURITY (password required).

**Table 3-10. 55300A Security Levels**

Security Access	Description
PUBLIC	No security—no password required, can use all commands without logging on. The Password Required bit switch on S1 is set to OFF.
SECURITY	Requires password, can use all commands including commands that download firmware. Password Required switch is set to ON.

### To Enable Security

To enable the security feature, perform the following steps.

- 1 Access S1 as shown in Figure 3-13 (on page 3-37).
- 2 Set bit switch B2 on S1 to its ON (Password Required) position as shown in Figure 3-15A.

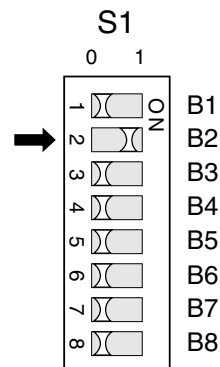

**B1** (Bit1) Preset All Serial Ports at Powerup

**B2** (Bit2) Password Required = ON; No Password Required = OFF

**Figure 3-15A. S1 Password Required Setting**

## Setting Up Security

- 3 If you choose not to use the default password (“GPS-SYNC!”) to disallow unauthorized users to operate the 55300A, use the ED-PID command to change the password. Refer to Chapter 4 in the *55300A GPS Telecom Primary Reference Source Programming Guide* for more information on ED-PID.
- 4 Re-install the 55300A module into the rack mount shelf, and power up the 55300A.

Once the 55300A is secured, re-installed, and powerup, you must enter or type the following commands:

ACT-USER::SUPER:123::GPS-SYNC!;—to log on and begin a session (Note: the default <pid> or password is “GPS-SYNC!”).

RTRV-HDR:::123;—to get a normal response (COMPLD) indicating the cable and all communications links are viable.

Note that if you try to enter a command without first logging on when the 55300A is secured, your command will be denied. The controller or terminal will echo back an error message.

Refer to Chapter 2, “Getting Started,” in the *55300A GPS Telecom Primary Reference Source Programming Guide* for more information.

## Setting Up Security

### To Disable Security

To disable the security feature, perform the following steps.

- 1 Access S1 as shown in Figure 3-13 (on page 3-37).
- 2 Set bit switch B2 on S2 to its OFF (No Password Required) position.

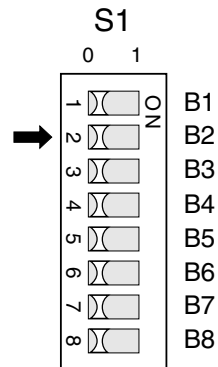

**B1** (Bit1) Preset All Serial Ports at Powerup

**B2** (Bit2) Password Required = ON; No Password Required = OFF

#### Figure 3-15B. S1 No Password Required Setting

- 3 Re-install the 55300A module into the rack mount shelf, power up the 55300A, and resume operation.

## Operating Concepts

### General

The time required to acquire GPS lock as described in the following paragraph can vary significantly depending on your local conditions. In general, Symmetricom strongly recommends that your antenna and cables be set up in accordance with the information provided in this guide prior to using the output signals of the 55300A to ensure they are valid.

Acquiring lock does not mean that the 55300A is fully operational and meeting all specifications. It just means that the 55300A has detected enough satellites to start its survey mode to determine its precise location. An internal measurement FFOM (Frequency Figure of Merit) becomes 0 when the internal loops reach their proper time constants, indicating that the output frequency and 1 PPS signals are now fully operational and meeting their specifications. Under the worst conditions, the 55300A may take up to 24 hours to achieve FFOM = 0. FFOM can be monitored in the Reference Outputs quadrant of the Receiver Status screen (see Figure 4-1 in Chapter 4, “Using the Receiver Status Screen,” of this guide). Also, using the appropriate SCPI query or TL1 retrieve command will provide FFOM value (refer to the programming guide for specifics).

The 55300A GPS Telecom Primary Reference Source is designed to automatically detect and acquire satellites in order to begin providing precise frequency and time information. Until such acquisition is complete and the instrument is locked with FFOM = 0, the signals produced on the rear (or top front) panel are not precise. However, it is possible to verify that the 55300A has been received in good working condition by performing the operational verification test upon receipt (refer to Chapter 2, “Acceptance Test”).

### Holdover Description

If the GPS signal is interrupted, the 55300A enters an intelligent holdover mode that uses SmartClock® technology. SmartClock takes over control of the quartz oscillator that has been steered to the GPS reference during locked operation. SmartClock predicts the performance of the quartz oscillator based on the information gathered during the “learning period” (locked to GPS). Corrections are automatically issued over time, keeping the performance of the quartz oscillator as close as possible to the performance achieved while locked to the GPS reference signal.

## Operating Concepts

Holdover frequency is maintained to better than  $\pm 1 \times 10^{-10}$  per day (phase accumulation  $< 8.6 \mu\text{s}$  after 1 day). When the GPS reference signal is restored, the 55300A automatically switches back to normal mode of operation.

## Understanding AIS, Squelched, and Continuous

### *AIS*

The Alarm Indication Signal (AIS) mode removes the formatted data from a formatted telecom output, it does not eliminate the output. By removing the formatted data it indicates that the telecom output is not valid or ready for use. Only formatted telecom outputs, such as **DS1** (1544 kbps) or **2048 kbps**, can be affected by AIS.

### *Squelched*

The Squelched mode eliminates or stops any normally formatted telecom output that has the capabilities of being specified as squelched. The **Output B** (55300A/53310A) or **2048 kHz/Squelched** (55300A/55320A/55322A) are such outputs.

### *Continuous*

The Continuous mode sets up the telecom outputs, such as **Output A** (55300A/55310A) or **2048 kHz/Continuous** (55300A/55320A/55322A), to always be present whether the 55300A is locked or not locked to GPS.

## Holdover Action of the Telecommunication Outputs

The 55300A's 1544 kbps or 2048 kbps telecom outputs are set at the factory to send an Alarm Indication Signal (AIS) when the 55300A has been operating in holdover for 86,400 seconds—1 day—(holdover duration threshold2).

The aforementioned factory defaulted holdover behavior can be altered or specified by sending the holdover duration threshold2 command:

```
ED-EQPT::GPS:<ctag>::THRESHOLD2 = <seconds>
```

The behavior of squelch and AIS are described in the following paragraphs.

## Operating Concepts

### ***Holdover Duration Exceeded***

If the holdover duration threshold2 is exceeded, the user-specified action is taken; that is, either squelch, AIS, or continue (does nothing; just continues to output signal). When the unit becomes locked again, the signal returns to normal.

### ***Powerup***

On powerup and after INIT-SYS::::5;, squelch will be asserted until the Phase-Lock-Loop (PLL) is locked to GPS.

### ***Preset***

The INIT-SYS::::9; command will reset the instrument to its preset state, like powerup, and therefore squelch will be asserted until the PLL is locked to GPS. The user-specified action is reset to the factory-default value of AIS.

### ***Action Command***

When you change the holdover action via the ED-EQPT::GPS:<ctag>:::HOLDACT = <value>; (where value can be one of three actions: SQUELCH, AIS, or CONTINUE) command, the squelch/AIS lines are immediately changed to match your new setting if the holdover threshold has been executed.

Refer to the programming guide for details on the following commands:

```
ED-EQPT::GPS:<ctag>:::THRESHOLD1 = ...
```

```
ED-EQPT::GPS:<ctag>:::THRESHOLD2 = ...
```

```
ED-EQPT::GPS:<ctag>:::HOLDACT = ...
```

---

## In Case of a Problem

### **Hours after powerup, 55300A not establishing GPS lock**

**Symptom** Date, time, and position still show power-up defaults, or these parameters are incorrect.

55300A Position Mode = Survey.

55300A cycling from one set of satellites to another.

No satellites consistently tracked.

**Solution** Make sure the 55300A module is fully seated into the rack mount shelf, and the screws are tightened. It is possible for the 55300A to receive power but not connect the antenna if not fully seated.

Check antenna:

- Verify antenna has an unobstructed view of the sky—antenna is not under or beside an impervious object.
- Verify antenna is connected.
- Verify antenna is connected properly:
  - cable run not too long.
  - cable with antenna attached neither shorted nor open.
- Verify antenna is being properly driven—*Hint:* (1) Connect Tee-connector to the **GPS ANTENNA** input; connect antenna cable to one end of Tee. Measure a little less than +5 Volts from the other end of the Tee using a digital voltmeter (DVM) as shown in Figure 3-16. If your reading is a lot less than +5 Volts, you will have to determine if the line amplifier or lightning arrester is at fault by using conventional troubleshooting isolation techniques. If the line amplifier and lightning arrester are good, then the antenna may be faulty. (2) If the 55300A's +5 Volts is okay, check +5 Volts at the antenna end of the cable with a voltmeter connected between the center conductor and shell. If insufficient voltage is present, it may indicate that the shield of the cable is not making adequate contact to one of the cable connectors.
- After the antenna connection has been verified, cycle power on the 55300A to facilitate rapid recovery from the fault.

**In Case of a Problem**

---

**NOTE**

---

Remove the Tee connector and restore antenna connection as loading of the Tee connector will prevent proper reception of the GPS signal by the antenna.

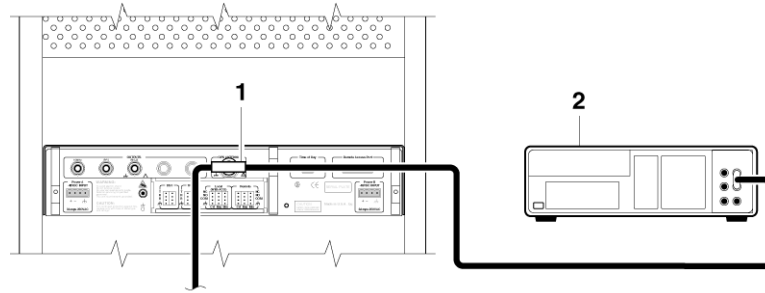

1 Tee-connector

2 DVM

**Figure 3-16. Measuring +5 Volts Across Antenna Input**

**Symptom** Same as previous symptoms, except 55300A Position Mode = Hold.

**Solution** Enable SURVEY mode using specified command.

**55300A not maintaining GPS lock**

**Symptom** Position data incorrect.

**Solution** Survey to obtain correct position,

or

Correct position data using specified command.

**Symptom** Position data correct.

Sufficient satellites in view.

No satellites tracked.

**Solution** If candidate satellites are marked “Ignore” on status screen, disable the feature which ignores satellites.

If candidate satellites are below the mask angle specified on the Receiver Status screen, lower the elevation mask angle using the proper command. Default is 10 degrees—all satellites between the horizon and 10 degrees of the horizon are masked.





---

## Chapter Contents

This chapter provides a tutorial section on how to use the Receiver Status screen, a comprehensive reference information section, and an illustrated foldout of the Receiver Status screen, which is a comprehensive summary of key operation conditions and settings.

This chapter is organized as follows:

- Using and Reading the Receiver Status Screen page 4-3
  - Tutorial on Using the Status Screen to Interface With the 55300A page 4-3
  - Demonstration of Holdover Operation page 4-8
- Receiver Status Screen Data page 4-11
  - SYNCHRONIZATION Section of the Status Screen page 4-12
  - ACQUISITION Section of the Status Screen page 4-14
  - HEALTH MONITOR Section of the Screen page 4-18
- The Receiver Status Screen at a Glance (foldout) page 4-19

---

## Using and Reading the Receiver Status Screen

The Receiver Status screen can be accessed when the 55300A is connected to a properly configured terminal or PC. There are three ways to access and use the Receiver Status screen:

- By installing a commercially available terminal emulation program, connecting the 55300A to a PC via the **TIME OF DAY** port, and manually sending the `:SYSTEM:STATUS?` query. (Refer to Chapter 1, “Getting Started,” in this guide.)
- By installing a commercially available terminal emulation program, connecting the 55300A to a PC via the **REMOTE ACCESS PORT** or **PORT 1** port, and manually sending the `RTRV-PM-EQPT:::123:::SYSTSTAT;` command. (Refer to Chapter 1, “Getting Started,” in this guide.)
- By installing and operating the SatStat program which automatically generates continual status screen updates, and connecting the 55300A to a PC via the **TIME OF DAY** port. (Refer to the sections titled “Installing the Automated SatStat Program for Continual Status Updates” and “Operating the Automated SatStat Program” in Chapter 1, “Getting Started,” of this guide for details on installation.)

The following tutorial demonstrates how you can use the Receiver Status screen to observe 55300A operation. The tutorial uses the manual (`RTRV-PM-EQPT:::123:::SYSTSTAT;`) method.

### **Tutorial on Using the Status Screen to Interface With the 55300A**

Type `RTRV-PM-EQPT:::123:::SYSTSTAT;`

An initial power-up screen is displayed, which is similar to the demonstration screen shown in Figure 4-1. The first data that you should look at is in the **SYNCHRONIZATION** area of the screen. It is telling you that it is in the Power-up state as indicated by the `>>` marker. That is, the 55300A has just been put on line.

Chapter 4 Using the Receiver Status Screen  
**Using and Reading the Receiver Status Screen**

```

----- Receiver Status -----
SYNCHRONIZATION ..... [ Outputs Invalid ]
SmartClock Mode _____ Reference Outputs _____
  Locked                    TFOM      9          FFOM      3
  Recovery                  1PPS TI  --
  Holdover                  HOLD THR 1.000 us
>> Power-up:GPS acquisition Holdover Uncertainty_____
                               Predict   --

ACQUISITION ..... [GPS 1PPS Invalid]
Tracking: 0 _____ Not Tracking: 6 _____
                PRN  El  Az                    Time _____
                *1  --  ---                    UTC      12:00:00[?] 01 Jan 1996
                *6  --  ---                    GPS 1PPS Invalid: not tracking
                *9  --  ---                    ANT DLY  0 ns
                *14 --  ---                    Position _____
                *22 --  ---                    MODE      Survey: 0% complete
                *24 --  ---                    Suspended:track <4 sats

ELEV MASK 10 deg *attempting to track INIT LAT N  0:00:00.000
HEALTH MONITOR ..... [ OK ]           INIT LON W  0:00:00.000
Self Test: OK Int Pwr: OK Oven Pwr: OK OCXO: OK  EFC: OK  GPS Rcv: OK
INIT HGT                                0 m (MSL)

```

**Figure 4-1. Receiver Status Screen at Powerup**

The ACQUISITION area of the screen is telling you that no satellites have been tracked. The identification numbers of several satellites appear in the Not Tracking column. The asterisk next to the satellite identification number, or pseudorandom noise code (PRN), indicates the 55300A is attempting to track it.

The current time and date are shown in the Time quadrant of the ACQUISITION area. The default power-up setting, indicated by [?], is corrected when the first satellite is tracked. Since the 55300A is not tracking any satellites, the GPS 1 PPS reference signal is invalid.

An accurate position is necessary to derive precise time from GPS. The Position quadrant indicates that the 55300A is in survey mode, which uses GPS to determine the position of the GPS antenna. This process has not yet started, since position calculations can be performed only while tracking four or more satellites. INIT LAT, INIT LON, and INIT HGT are the initial estimate of the true position. These coordinates are refined by the survey process. The 55300A uses this position and the time-of-day to select satellites to track. Therefore, you can reduce satellite acquisition time by specifying an close approximation of position and time.

Now, let's send the RTRV-PM-EQPT:::123:::SYSTSTAT; command again to see what kind of progress the 55300A has made.

## Using and Reading the Receiver Status Screen

You can now see that the 55300A is tracking several satellites as shown in Figure 4-2. The process of acquiring and tracking satellites is described in the following paragraphs.

```

----- Receiver Status -----
SYNCHRONIZATION..... [ Outputs Valid/Reduced Accuracy ]
SmartClock Mode _____ Reference Outputs _____
>> Locked to GPS: stabilizing frequency TFOM 6 FFOM 1
Recovery 1PPS TI +71 ns relative to GPS
Holdover HOLD THR 1.000 us
Power-up Holdover Uncertainty _____
Predict --

ACQUISITION ..... [GPS 1PPS Valid]
Tracking: 5 _____ Not Tracking: 4 _____
PRN El Az SS PRN El Az Time _____
2 70 337 134 9 11 292 UTC 17:56:44 31 Jan 1996
7 46 188 117 16 24 243 GPS 1PPS Synchronized to UTC
15 33 82 54 *26 Acq.. ANT DLY 0 ns
19 28 113 29 31 -- --- Position _____
22 65 91 128 MODE Survey: 1.2% complete

AVG LAT N 37:19:34.746
AVG LON W 121:59:50.502
AVG HGT +34.14 m (MSL)
ELEV MASK 10 deg *attempting to track
HEALTH MONITOR ..... [ OK ]
Self Test: OK Int Pwr: OK Oven Pwr: OK OCXO: OK EFC: OK GPS Rcv: OK

```

**Figure 4-2. Receiver Status Screen Displaying Initial Satellite Acquisition**

An asterisk (\*) next to the PRN of a satellite in the Not Tracking column indicates the 55300A is attempting to track it. The elevation (El) and azimuth (Az) angles of the satellite are indicated. Acq . or Acq .. tell you that the 55300A is attempting to track that satellite. One dot after the Acq indicator shows that the 55300A is attempting to acquire its signal, and two dots indicate impending lock. Eventually, you will see the satellite move from the Not Tracking column, which shows the satellite PRN, the elevation angle of the satellite in the sky (90° being zenith), the azimuth angle (number of degrees bearing from true north), and the signal strength (SS). A good signal strength is a number above 20, which would be efficient for the 55300A to operate. Numbers below 20, suggest intermittent tracking of the satellite or no tracking; check your antenna system should this be the case.

As indicated by the demonstration screen in Figure 4-2, the 55300A is now surveying for position. It is tracking four satellites which is the minimum number that must be tracked to determine position. As you can see, the Position MODE line indicates survey is 1.2% complete. A complete survey would take two hours during which four satellites or more are continuously tracked.

### Using and Reading the Receiver Status Screen

Also, you can see the initial (estimated) position has been replaced with a computed position, which the 55300A continues to refine until it gets a very accurate position. The status screen indicates that a computed position is being used by displaying the averaged latitude, and longitude height (AVG. LAT, AVG LON, and AVG HGT).

If the position were not precise, GPS timing information would be inaccurate by an amount corresponding to the error in the computed position. An error in the computed position of the antenna translates into an error in the derived time and will compromise the 55300A's ability to be a timing source (but not a frequency source).

Let's consider a case where four satellites are not visible at powerup because of a poor antenna location, such as an "urban canyon" (located between tall city buildings). If accurate position is known from a Geodetic survey of that site, it can be programmed with the position command (Note: Enter the position of the antenna not the 55300A.), thereby bypassing the survey operation. This is useful when four satellites cannot be tracked for an extended period of time.

Let's send the `RTRV-PM-EQPT:::123:::SYSTSTAT;` command again to observe the current status of the 55300A.

The updated demonstration status screen in Figure 4-3 indicates that the position survey is now 5.4% complete. Thus, the survey task is beginning to iterate toward an accurate position. In the Time quadrant, the UTC time is now correct. The date is correct, and the GPS reference signal is synchronized to UTC.

## Using and Reading the Receiver Status Screen

```

----- Receiver Status -----
SYNCHRONIZATION ..... [ Outputs Valid/Reduced Accuracy ]
SmartClock Mode _____ Reference Outputs _____
>> Locked to GPS: stabilizing frequency TFOM 4 FFOM 1
Recovery 1PPS TI +20 ns relative to GPS
Holdover HOLD THR 1.000 us
Power-up Holdover Uncertainty _____
Predict 432.0 us/initial 24 hrs

ACQUISITION ..... [GPS 1PPS Valid]
Tracking: 6 _____ Not Tracking: 1 _____
PRN El Az SS PRN El Az Time _____
2 70 301 82 16 13 258 UTC 18:47:07 31 Jan 1996
7 35 186 71 GPS 1PPS Synchronized to UTC
19 40 102 61 ANT DLY 0 ns
22 71 60 84 Position _____
26 19 317 54 MODE Survey: 5.4% complete
31 16 41 52

AVG LAT N 37:19:34.937
AVG LON W 121:59:50.457
AVG HGT +67.94 m (MSL)
ELEV MASK 10 deg
HEALTH MONITOR ..... [ OK ]
Self Test: OK Int Pwr: OK Oven Pwr: OK OCXO: OK EFC: OK GPS Rcv: OK

```

**Figure 4-3. Receiver Status Screen Displaying Progress Towards Steady-State Operation**

In the SYNCHRONIZATION area, the >> marker is pointed at the Locked to GPS line, indicating that the 55300A is locked to GPS and stabilizing the frequency of its oscillator. This means that the 55300A has phase-locked its oscillator to the 1 PPS reference signal provided by GPS, but it is not at its final, or most stable, state. The 55300A is locked and the front-panel **GPS Lock** LED is illuminated.

For users without the command interface (PC/Terminal emulator connected to the 55300A), the illuminated **GPS Lock** LED is probably the first indication that after powerup that the 55300A is moving towards a stable state.

With the command interface and status screen, you can get more detailed information. For example, you can read the reference outputs quality indicators in the Reference Outputs area of the status screen. These are the Time Figure of Merit (TFOM) and Frequency Figure of Merit (FFOM) indicators. As shown in Figure 4-3, the TFOM is 4 and the FFOM is 1. These values will eventually decrease towards the ultimate values that represent steady-state performance. Refer to the subsection titled “Reference Outputs,” on page 4-13 in this chapter for more information about TFOM and FFOM.

Also indicated is a prediction of the accuracy of the 55300A should it go into holdover operation.

## **Demonstration of Holdover Operation**

---

**CAUTION**

The 55300A typically reaches stable state 24 hours after powerup, and it will learn best if its experiences no holdover in the first 24 hours. Therefore, the holdover demonstration in the following paragraphs will compromise the 55300A's ability to learn the characteristics of its internal reference oscillator. For the purpose of education only, you will be shown how to initiate a holdover.

A user should *never* initiate holdover during the first 24 hours while the 55300A is learning its internal oscillator characteristics. The 55300A should maintain GPS lock during this time because it is using the GPS signal to discipline the oscillator. It will learn what the oscillator drift characteristics are relative to the GPS signal. It will learn how the oscillator ages, and the software will learn how to compensate for that aging.

Thus, it is recommended that the 55300A is always kept locked to GPS during the first 24 hours.

---

For demonstration purposes, and since the 55300A has been powered up for a while, let's put the 55300A into holdover by simply removing the antenna connection. The following will occur:

- The front-panel **Holdover** LED will illuminate, and
- after sending the `RTRV-PM-EQPT:::123:::SYSTSTAT;` command again, a screen similar to Figure 4-4 should appear.

Let's send the `RTRV-PM-EQPT:::123:::SYSTSTAT;` command. Figure 4-4 should appear.



## Using and Reading the Receiver Status Screen

```

----- Receiver Status -----
SYNCHRONIZATION ..... [ Outputs Valid/Reduced Accuracy ]
SmartClock Mode _____ Reference Outputs _____
  Locked to GPS                TFOM      3           FFOM      2
  Recovery                    1PPS TI   --
>> Holdover: GPS 1PPS invalid  HOLD THR  1.000 us
  Power-up                    Holdover Uncertainty _____
                               Predict 432.0 us/initial 24 hrs
                               Present 1.0 us
                               Holdover Duration: 0m 14s
ACQUISITION ..... [GPS 1PPS Invalid]
Tracking: 0 _____ Not Tracking: 7 _____
      PRN  El  Az  PRN  El  Az  Time _____
      *2   71 316 *31  12  29  UTC      20:56:14  31 Jan 1996
      *7   41 186                GPS 1PPS Inaccurate: not tracking
      15  11  86                ANT DLY  0 ns
      *19  35 107                Position _____
      *22  68  78                MODE      Survey: 71.1% complete
      *26  23 314                LAT       N 37:19:32.472
                               LON       W 121:59:51.784
ELEV MASK 10 deg *attempting to track HGT                +42.19 m (MSL)
HEALTH MONITOR ..... [ OK ]
Self Test: OK Int Pwr: OK Oven Pwr: OK OCXO: OK EFC: OK GPS Rcv: OK

```

**Figure 4-4. Receiver Status Screen Displaying Holdover Operation**

In the SYNCHRONIZATION area, you can see that the 55300A has gone into holdover as indicated by >> marker that is pointing at the Holdover line. The status screen indicates that the reason the 55300A is in holdover is because the GPS I PPS reference signal is invalid.

You would expect this since the antenna has been disconnected.

The status screen shows, instantaneously, loss of the GPS signal. As you can see on the screen, all of the satellites in the Tracking column moved into the Not Tracking column.

The status screen in Figure 4-4 shows that the 55300A has been in holdover operation for 14 seconds.

If the 55300A's SmartClock had had enough time to learn the internal oscillator characteristics (24 hours), the 55300A status screen would show that the 55300A went into holdover, and the 55300A's outputs were maintained during holdover by the SmartClock.

When the GPS antenna is re-connected and the GPS signal has been re-acquired, the 55300A has the ability to recover from holdover by itself. The SYNCHRONIZATION area of the screen will show the >> marker pointing at the Recovery line (and then eventually at the Locked to GPS line), the GPS Lock LED will illuminate, and the screen will look similar to Figure 4-5.

Chapter 4 Using the Receiver Status Screen  
**Using and Reading the Receiver Status Screen**

```

----- Receiver Status -----
SYNCHRONIZATION .....[ Outputs Valid/Reduced Accuracy ]
SmartClock Mode _____ Reference Outputs _____
>> Locked to GPS: Stabilizing frequency   TFOM      3           FFOM      1
Recovery                               1PPS TI +10.6 ns relative to GPS
Holdover                               HOLD THR 1.000 us
Power-up                               Holdover Uncertainty _____
                                       Predict 432.0 us/initial 24 hrs

ACQUISITION ..... [GPS 1PPS Valid]
Tracking: 6 _____ Not Tracking: 0 _____
PRN  El  Az  SS           Time _____
  2  71 317 80           UTC      20:59:28   31 Jan 1996
  7  34 185 73           GPS 1PPS Synchronized to UTC
 19  41 101 64           ANT DLY  0 ns
 22  67  80 87           Position _____
 26  24 312 55           MODE      Survey: 71.4% complete
 31  12  27 49           LAT      N  37:19:32.486
                                       LON      W 121:59:52.082
                                       HGT      +40.06 m (MSL)

ELEV MASK 10 deg
HEALTH MONITOR ..... [ OK ]
Self Test: OK Int Pwr: OK Oven Pwr: OK OCXO: OK EFC: OK GPS Rcv: OK

```

**Figure 4-5. Receiver Status Screen Following Recovery From Holdover Operation**

You can see the 55300A has recovered from holdover almost immediately and it has returned to locked operation.

---

## Receiver Status Screen Data

This section defines the data displayed in the Receiver Status screen, shown in Figure 4-6.

```

----- Receiver Status -----
SYNCHRONIZATION ..... [ Outputs Valid ]
SmartClock Mode _____ Reference Outputs _____
>> Locked to GPS                TFOM      3                FFOM      0
  Recovery                       1PPS TI +7.2 ns relative to GPS
  Holdover                       HOLD THR 1.000 us
  Power-up                       Holdover Uncertainty _____
                                Predict  49.0 us/initial 24 hrs

ACQUISITION ..... [GPS 1PPS Valid]
Tracking: 6 ____ Not Tracking: 1 _____
PRN  El  Az  SS  PRN  El  Az                Time _____ +1 leap second pending
  2   49 243 168   14  11  82                UTC      23:59:59   31 Dec 1995
 16   24 282 125                                GPS 1PPS Synchronized to UTC
 18   38 154 132                                ANT DLY  120 ns
 19   65  52 168                                Position _____
 27   62 327 246                                MODE      Survey: 17.5% complete
 31   34  61 133                                AVG LAT  N  37:19:32.264
                                                AVG LON  W 121:59:52.112
                                                AVG HGT                      +41.86 m (MSL)

ELEV MASK 10 deg
HEALTH MONITOR ..... [ OK ]
Self Test: OK Int Pwr: OK Oven Pwr: OK OCXO: OK EFC: OK GPS Rcv: OK

```

**Figure 4-6. Sample Status Screen**

The status screen has three major sections:

- SYNCHRONIZATION
- ACQUISITION
- HEALTH MONITOR

The SYNCHRONIZATION section of the status screen shows how the 55300A's SmartClock™ technology is progressing towards its objective, which is to synchronize the 55300A's oscillator to the 1 PPS reference signal produced by the 55300A's internal GPS Engine.

The ACQUISITION section of the status screen shows how the 55300A's internal GPS Engine is progressing towards its objective, which is to produce an accurate internal 1 PPS reference signal. It does so through tracking GPS satellites.

The HEALTH MONITOR section of the status screen summarizes the overall health of the product.

## Receiver Status Screen Data

### **SYNCHRONIZATION Section of the Status Screen**

#### ***SYNCHRONIZATION Summary Line***

The **SYNCHRONIZATION** line in the screen summarizes the **SmartClock Status** and **Reference Outputs**. One of three SYNCHRONIZATION messages is shown:

- |                                            |                                                                                            |
|--------------------------------------------|--------------------------------------------------------------------------------------------|
| <i>Outputs Invalid</i>                     | while the 55300A (unit) is warming up,                                                     |
| <i>Outputs Valid/<br/>Reduced Accuracy</i> | while the unit is in holdover or is locked but has not achieved steady-state operation, or |
| <i>Outputs Valid</i>                       | while the unit is in steady-state operation.                                               |

#### ***SmartClock Mode***

The SmartClock Mode area of the screen shows the four operating modes:

- Locked to GPS
- Recovery
- Holdover
- Power-up

As shown in the sample status screen in Figure 4-6, a >> symbol indicates the current operating mode.

**Locked to GPS** indicates that the 55300A is locked to GPS. The front-panel **GPS Lock** LED will be illuminated.

When *stabilizing frequency ...* is shown, the time output (1 PPS) signal is locked and can be used, but the frequency outputs (10 MHz, 1544 kHz or 2048 kHz) are not at their final or most stable state.

**Recovery** indicates that the 55300A is actively working to become locked to GPS. All conditions needed to proceed towards a lock have been met. Expect an eventual spontaneous transition to a lock (unless changing external conditions prevent this, such as loss of tracked satellites.)

**Holdover** indicates that the 55300A is waiting for conditions that are needed to allow the process of recovery from holdover to begin. Once these conditions are met, the 55300A will transition on its own to the recovery mode.

When the *GPS 1PPS CLK invalid* message follows the **Holdover** label, the internal GPS 1 PPS reference signal is inaccurate.

**Receiver Status Screen Data**

When the *manually initiated* message follows the **Holdover** label, the 55300A has been placed in holdover by the user. An explicit command is required to initiate an exit from manual holdover.

When the *internal hardware problem* message follows the **Holdover** label, a measurement hardware error exists.

The *Holdover Duration* message indicates the duration that the 55300A has been operating in holdover (and recovery). Thus, this message gives you an assessment of the quality of the outputs. The longer the 55300A is in holdover the more degraded the outputs become.

**Power-up** indicates that the 55300A hasn't yet achieved GPS lock or acquired satellites since it has been powered up. The 55300A is measuring the internal reference oscillator's frequency and adjusting it to 10 MHz during this power-up period. Other queries can provide insight as to the cause if the 55300A is remaining in powerup longer than expected.

**Reference Outputs**

**TFOM** (Time Figure of Merit) indicates the *accuracy* of the 55300A's 1 PPS output. A low TFOM value indicates a more accurate output. In the sample screen of Figure 4-6, a value of 3 is displayed, meaning that the Time Error ranges from 100 to 1000 nanoseconds. The following table lists the TFOM values that could be displayed and the corresponding Time Error.

TFOM Value	Time Error (in nanoseconds)	TFOM Value	Time Error (in nanoseconds)
*0	less than 1	5	$10^4-10^5$
*1	1-10	6	$10^5-10^6$
*2	10-100	7	$10^6-10^7$
3	100-1000	8	$10^7-10^8$
4	$10^3-10^4$	9	greater than $10^8$

\* The TFOM values 0, 1, and 2 are not presently used in the 55300A. The 55300A will display TFOM values ranging from 9 to 3, which is consistent with the specified accuracies of each product.

**FFOM** (Frequency Figure of Merit) indicates the *stability* of the 55300A's 10 MHz output. The 10 MHz output is controlled by the SmartClock's Phase-Locked Loop (PLL). Thus, the FFOM value is determined by monitoring the status of the PLL.

**Receiver Status Screen Data**

In the sample screen of Figure 4-6, the 0 indicates that the SmartClock's PLL is stabilized. The following table lists and defines the FFOM values that could be displayed.

<b>FFOM Value</b>	<b>Definition</b>
0	PLL stabilized—10 MHz output within specification.
1	PLL stabilizing
2	PLL unlocked (holdover)—Initially the 10 MHz output will be within specifications. However, when in holdover, the 10 MHz output will eventually drift out of specification.
3	PLL unlocked (not in holdover)—Do not use the output.

**1PPS TI** indicates the difference (timing shift) between the SmartClock 1 PPS and the internal GPS 1 PPS signals.

**HOLD THR** (holdover threshold) displays the user-entered time error value.

**ACQUISITION Section of the Status Screen*****ACQUISITION Line***

The **ACQUISITION** line in the screen summarizes the state of the internal GPS 55300A Engine as indicated by the **Tracking**, **Not Tracking**, and **Position** areas of the screen.

If the Receiver Engine was considered to be synchronized to the GPS signal, the [*GPS 1 PPS Valid*] message will appear at the end of the **ACQUISITION** line. If the 55300A has not yet synchronized to GPS, the [*GPS 1 PPS CLK Invalid*] message will be displayed.

***Tracking, Not Tracking***

The **Tracking** table indicates the number of satellites the unit is tracking.

The **Not Tracking** table indicates satellites predicted to be visible that are not tracked, and all of the satellites that are assigned to a GPS Engine channel but are not currently tracked.

### Receiver Status Screen Data

Health and status indicators in the tables are defined as follows:

<b>PRN</b>	indicates the pseudorandom noise code assigned to the satellite.
<b>EI</b>	indicates the predicted elevation angle, from a range of 0 to 90°. The predicted elevation is derived from the almanac.
<b>--</b>	indicates that the elevation angle is unknown (the almanac did not provide this data).
<b>Az</b>	indicates the predicted azimuth angle, from a range of 0 to 359°. The predicted azimuth angle is referenced to true north, and is derived from the almanac.
<b>---</b>	indicates that the azimuth angle is unknown (the almanac did not provide this data).
<b>SS</b>	indicates the strength of the signal, from a range of 0 to 255. A signal strength of 20 to 30 is a weak signal that may not be acquired by the 55300A.

The health and status indicators in the **Not Tracking** table are described as follows:

<i>Ignore</i>	indicates that the user has chosen to exclude this satellite from a list of satellites available for tracking.
<i>Not OK</i>	indicates GPS has reported that this satellite is unhealthy.
<i>Acq</i>	indicates the unit is attempting to acquire the satellite signal.
<i>Acq .</i>	indicates the unit is reading timing information from the satellite.
<i>Acq . .</i>	indicates the unit is reading satellite orbital information.
<b>ELEV MASK</b>	indicates the elevation mask angle in degrees. Satellites at or above this elevation angle are considered for tracking.

*\*attempting to track* indicates that the unit is attempting to track a satellite.

## Receiver Status Screen Data

### *Time*

When you first power up the unit the time and date that is stored in the internal GPS Engine may not be the actual date. The actual time and date will be valid after one satellite has been tracked by the 55300A.

---

**NOTE**

---

There are two accurate ways to express time (GPS or UTC). GPS time is offset from UTC time by the number of accumulated leap seconds since midnight of January 6, 1980 UTC.

The **Time** area of the status screen provides three types of information: **Time**, **1PPS CLK**, and **ANT DLY**.

**Time** has four possible modes: *GPS*, *UTC*, *LOCL GPS*, and *LOCAL*.

*GPS* indicates current time and date collected from a satellite in GPS Time.

*LOCL GPS* indicates GPS Time, offset for the local time zone.

*UTC* indicates current time and date collected from a satellite in UTC time.

*LOCAL* indicates current time and date collected from a satellite offset from UTC for the local time zone.

**1PPS CLK** can indicate several possible advisory messages. These messages are:

<i>Synchronized to GPS Time</i>	1 PPS locked to GPS, referenced to GPS Time.
<i>Synchronized To UTC</i>	1 PPS locked to GPS, referenced to UTC.
<i>Assessing stability ...</i>	applying hysteresis to locked 1 PPS signal.
<i>Inaccurate, not tracking</i>	not tracking satellites.
<i>Inaccurate, inacc position</i>	in survey mode, but has not yet calculated a position.
<i>Absent or freq incorrect</i>	no 1PPS signal; or the internal GPS Engine is idle.

**ANT DLY** (antenna delay) displays the user-entered value that is used to compensate for the propagation delay of the antenna cable.



## Receiver Status Screen Data

### *Position*

**Position** area of the status screen provides four types of information: **MODE** (hold or survey), **LAT** (latitude), **LON** (longitude), and **HGT** (height).

**MODE** indicates whether the unit is set to Hold or Survey position mode.

When *Hold* is displayed, the unit's antenna position has been provided by the user, or the average position has been found after completion of survey.

If the unit is in the position *Hold* mode, the **LAT**, **LON**, and **HGT** "held" position coordinates will be displayed.

If *Survey: 57.3% complete* is displayed, for example, the 55300A is set to survey mode trying to determine the position of the antenna. The % value indicates the progress of the surveying.

At the beginning of a survey (0% completion), the following "estimated" position coordinates will be displayed:

**INIT LAT** indicates the estimated latitude (North or South) position of the unit in degrees, minutes, and seconds.

**INIT LON** indicates the estimated longitude (East or West) position of the unit in degrees, minutes, and seconds.

**INIT HGT** indicates estimated height of the unit's antenna, in meters above mean sea level (MSL).

Once survey starts, the following "averaged" position coordinates will be displayed:

**AVG LAT** indicates the average latitude (North or South) position of the unit in degrees, minutes, and seconds.

**AVG LON** indicates the average longitude (East or West) position of the unit in degrees, minutes, and seconds.

**AVG HGT** indicates average height of the unit's antenna, in meters above mean sea level (MSL).

## Receiver Status Screen Data

The possible advisory messages that can be displayed when position mode is Survey are:

*Suspended: track <4 sats*

*Suspended: poor geometry*

*Suspended: no track data*

## HEALTH MONITOR Section of the Screen

The HEALTH MONITOR section of the status screen reports errors or failures of the key hardware functions. The OK summary message at the end of the **HEALTH MONITOR** line indicates that no errors or failures were detected. *Error* indicates that one or more hardware tests failed.

For each hardware function, *OK* is reported when it is operating normally; *Err* is displayed when a failure or an error is detected.

Hardware functions are monitored periodically, with the exception of Self Test, which is performed at powerup or when requested.

The health and status indicators in the HEALTH MONITOR section are described as follows:

<b>Self Test</b>	Last diagnostic check of the microprocessor system, reference oscillator, satellite receiver, and power supplies failed.
<b>Int Pwr</b>	Internal power supply voltage(s) exceeds tolerance.
<b>Oven Pwr</b>	Oscillator oven power supply voltage exceeds tolerance.
<b>OCXO</b>	Oscillator output failed, or the output is squelched.
<b>EFC</b>	Oscillator control voltage is at or near full-scale.
<b>GPS Rcv</b>	Satellite receiver communication failed, or GPS 1PPS reference is absent.

---

## The Receiver Status Screen at a Glance

Refer to the following pages.

The Receiver Status Screen at a Glance

**SYNCHRONIZATION**

**SYNCHRONIZATION** profiles the process of synchronizing time and frequency reference signals with GPS.

SmartClock technology compares and adjusts (locks) the reference oscillator to GPS. In the absence of GPS, SmartClock operates in "holdover" mode, which maintains precise time and frequency over an extended duration by predicting and compensating for aging and temperature effects.

**SmartClock Mode**

**Locked to GPS**

Reference signals are synchronous with GPS. When stabilizing frequency is reported, short-term frequency errors limit the accuracy of the 10-MHz reference.

**Recovery: ...**

Adjusting the frequency and phase of the oscillator to correct errors accrued while in holdover operation. The phase difference between the GPS 1PPS reference and disciplined oscillator 1PPS signal is shown.

**Holdover: ...**

Reference outputs are not synchronous with GPS due to the reported condition. SmartClock maintains timing accuracy by applying learned oscillator characteristics.

GPS 1PPS invalid

Not tracking any satellites, or position is inaccurate

1PPS TI exceeds hold threshold

Phase difference between 1PPS signals exceeds a specified limit (**HOLD THR**)

manually initiated

User-initiated holdover.

**Holdover Duration** is the cumulative duration of holdover and recovery operations.

**Power-up: ...**

Warm-up/initial adjustment of the oscillator.

**Reference Outputs**

Measures of signal quality:

**TFOM** (Time Figure of Merit)

Accuracy of the 1PPS reference. A number between 0 (best) and 9 that denotes a timing error of  $10^{TFOM-1}$  to  $10^{TFOM}$  nanoseconds.

**FFOM** (Frequency Figure of Merit)

Frequency stability of the 10-MHz reference:

0 – Stable, signal within specification

1 – Stabilizing this signal

2 – Holdover mode; frequency will drift

3 – Signal is unusable.

**1PPS TI** (Time Interval)

Average phase difference between the GPS reference and oscillator 1PPS signals.

**HOLD THR** (Holdover Threshold)

1PPS phase difference that while exceeded forces holdover operation.

```

----- Receiver
SYNCHRONIZATION .....
SmartClock Mode .....
  Locked
>> Recovery: phase alignment [TI +1.296 us:
  Holdover
  Power-up

                                Holdover Duration: 1m 45s

ACQUISITION .....
Tracking: 1 _____ Not Tracking: 9 _____
PRN  El  Az  SS  PRN  El  Az  PRN  El  Az
 31  75 254 168  * 2  19 313  29  Not OK
                * 4  Acq
                * 5  Acq .
                * 7  -- ---
                * 9  35 140
                15  Ignore
                *24  Acq ..
                *26  47 258
ELEV MASK 10 deg *attempting to track

HEALTH MONITOR .....
Self Test: OK  Int Pwr: OK  Oven Pwr: OK
    
```

**HEALTH MONITOR**

**HEALTH MONITOR** reports the operational status of key receiver components and internal signals.

**Self Test** – Result of the last diagnostic check of the processor system, reference oscillator, satellite receiver and power supplies

**Int Pwr** – Internal power supplies

**Oven Pwr**– Oscillator oven power supply

**OCXO** – Oscillator 1PPS output

**EFC** – Oscillator frequency control voltage

**GPS Rcv** – Satellite receiver communication interface.

**Holdover Uncertainty**

Estimations of timing accuracy while in holdover mode, which reflect the extent to which SmartClock has learned the oscillator's characteristics:

**Predict**

Maximum timing error that can be expected over the initial 24 hours of holdover operation.

**Present**

Maximum timing error currently expected.

The Receiver Status Screen at a Glance

```

Status -----
[ Outputs Valid/Reduced Accuracy ]
Reference Outputs -----
TFOM      3          FFOM      2
1PPS TI   --
HOLD THR  1.000 us
Holdover  Uncertainty-----
Predict   55.8 us/initial 24 hrs
Present   1.0 us
.....[ GPS 1PPS Valid ]
Time -----
UTC       03:11:57   31 Jan 1996
GPS 1PPS  Synchronized to UTC
ANT DLY   120 ns
Position -----
MODE      Survey: 26.1% complete
          Suspended: track <4 sats
AVG LAT   N 37:19:31.797
AVG LON   W 121:59:52.018
AVG HGT   60.52 m (MSL)
.....[ OK ]
OEXO: OK  EFC: OK  GPS Rcv: OK
    
```

**ACQUISITION**

**ACQUISITION** profiles the process of acquiring precise time from GPS. GPS provides time-of-day information and a 1PPS reference signal used to discipline the internal oscillator.

**Time**

---

Time of day:

- UTC**            – Coordinated Universal Time
- LOCAL**       – UTC with local time zone offset
- GPS**           – GPS Time
- LOCL GPS**   – GPS Time, with time zone offset.

[ ? ] identifies a default power-up setting that is corrected when the first satellite is tracked.

+1 (or -1) leap second pending is reported if a leap second correction to UTC is pending.

**GPS 1PPS** indicates the validity of the GPS 1PPS reference:

- Synchronized to UTC (or GPS Time)
- 1PPS reference is synchronous with GPS

Questionable accuracy...

Assessing stability...

- 1PPS must be accurate for 35 seconds

Inaccurate: not tracking

- One or more satellites must be tracked

Inaccurate: inacc position

- Position must be known to derive time

Inaccurate: Time RAIM err

- GPS timing integrity is suspect.

**ANT DLY** offsets the GPS 1PPS reference to compensate for signal propagation delays introduced by the antenna system. (Time is referenced to the position of the antenna.)

**Position**

---

An accurate position is necessary to transfer time from GPS. Two position **MODEs** are provided, hold and survey.

In **Hold** mode, a fixed position is used to derive time. This position may be specified if known, or determined by the survey process.

In **Survey** mode, position is determined from GPS. Four or more satellites must be tracked. Successive positional estimates (pseudoranges) are refined to obtain the true position, which is entered as the held position at the completion of this process.

Averaged (**AVG**) position coordinates and progress are reported while surveying. When surveying is suspended, an advisory message describes the reason:

Suspended: track <4 sats

- Four or more satellites must be tracked to determine position

Suspended: poor geometry

- DOP (dilution of precision) is too large for an accurate pseudo-range measurement.

Specifying an approximate initial (**INIT**) position will reduce satellite acquisition time.

**Tracking**

---

Satellites currently tracked by the receiver. Four or more satellites must be tracked to determine position. Timing information is derived from all tracked satellites, and is considered accurate while tracking at least one satellite from a known position. The receiver selects satellites highest in the sky that are at or above the minimum elevation angle specified by **ELEV MASK**.

**Not Tracking**

---

Satellites considered for tracking. These satellites are predicted to be visible or are selected by the "sky search" algorithm. Visibility is predicted from the satellite almanac, current time and position.

Tracking and Not Tracking tables provide supplemental information about satellite position, signal strength and health:

- PRN**       – Identification number (pseudorandom noise code) assigned to the satellite. Satellites are sorted by ascending PRNs.
- EI**       – Elevation of the satellite (degrees) predicted by the almanac. "---" denotes it is unknown, such as when the satellite is not predicted to be visible but is selected for tracking by the sky search algorithm.
- Az**       – Azimuth of the satellite (degrees), referenced to true north, predicted by the almanac; "---" if unknown.
- SS**       – Relative signal strength, proportional to the signal-to-noise ratio of the received signal. The maximum value is 255; 20 to 30 is the minimum range for stable tracking.
- Acq**      – Locking code and carrier tracking loops to initially acquire the satellite signal.
- Acq .**     – Demodulating the satellite broadcast (NAV) message, and determining current time.
- Acq ..**    – Reading the satellite ephemeris (orbital information) from the NAV message.
- Ignore**   – The satellite is excluded from the selection process.
- Not OK**   – GPS or Time RAIM reports the satellite is unhealthy.





---

## Introduction

The specifications and characteristics of the 55300A GPS Telecom Primary Reference Source are provided in this chapter.



**Introduction**

**Specifications and Characteristics of 55300A  
GPS Telecom Primary Reference Source Module**

Primary Reference Source (PRS) Features:

- Cesium-like (Stratum 1) performance at one-tenth the cost meets the requirements of GR-2830-CORE, ITU-T G.811, and ANSI T1.101-1994
- Highly reliable quartz oscillator with SmartClock technology
- Six-channel, parallel tracking GPS engine with enhanced GPS technology
- Time-of-day (TOD) features to synchronize computer systems using Network Time Protocol

**Performance Specifications**

Description	Specification
Stratum 1/Level 1—Accuracy	$< 1 \times 10^{-12}$ when locked to GPS (24 hour average)
Holdover Stability	$< 1 \times 10^{-10}$ /day (See Notes 1 and 2.)
Outputs Available (as specific options)	Opt 104, 1544 kbps, 100Ω balanced, D4 Opt 105, 1544 kbps, 100Ω balanced, ESF Opt 220, 2048 kbps, 120Ω balanced, CCS Opt 221, 2048 kbps, 120Ω balanced, CAS Opt 222, 2048 kbps, 120Ω balanced, CCS-CRC4 Opt 270, 2048 kbps, 75Ω unbalanced, CCS Opt 271, 2048 kbps, 75Ω unbalanced, CAS Opt 272, 2048 kbps, 75Ω unbalanced, CCS-CRC4
Standard Outputs	1544 kHz or 2048 kHz, 1 PPS and 10 MHz
MTBF of Oscillator (Typical Characteristic)	> 500,000 hours
Cold Startup	Achieves GPS lock in less than 30 minutes (assumes “normal” view of sky)
Time of Day (TOD)—Standard connector	RS-232 UNIX Network Time Protocol or IRIG-B
Port 1 (local access port—front of module)	DE-9S, DCE female
Monitor Port (front of module)	Standard telecommunication bantam jack
Weight of 55300A module	3.7 lbs (1.7 kg)

**Note 1.** This specification has a 95% probability, and is based on the availability of four or more GPS satellites during three days of locked operation with a fixed antenna location. The temperature must remain within a 10° range between 10°C and 40°C.

**Note 2.** When a quartz crystal oscillator has not been operated for a period of time, or if it has been subjected to severe thermal or

mechanical shock, as might be encountered during product shipment, the oscillator may take some time to stabilize. In most cases, the oscillator will drift and then stabilize at or below its specified rate within a few days after being turned on. In isolated cases, depending upon the amount of time the oscillator has been off and the environmental conditions it has experienced, the oscillator may take up to one week to reach its

specified aging rate and to operate without significant frequency “jumps.”

A GPS Receiver, when it is initially turned on and locked to the GPS satellite system, will achieve GPS lock within 30 minutes of operation. The longer the GPS Receiver (and its quartz oscillator) operates, the better its stability and unlocked (holdover) performance becomes.

## Introduction

## Specifications for Outputs

Description	Specification
<b>1544 kbps (DS1) Output (Options 104, 105)</b>	Framed all 1s, ESF or D4, switch selectable AMI (B8ZS) Traceable to UTC ITU-T G.703, Table 4, Fig 10
Impedance	100Ω Balanced
MTIE & TDEV	Meets requirements of GR-2830 for PRS
<b>1544 kHz Output</b>	
Output Type	1544 kHz per ITU-T G.703, Table 10, Fig 21
Wave Form	75Ω : 1.5 V peak maximum, 0.75 V peak minimum
Wave Shape	Square Wave
Impedance	75Ω, unbalanced
<b>10 MHz Output</b>	
Frequency Accuracy—Locked	$< 1 \times 10^{-12}$ , one day average
Holdover aging	$< 1 \times 10^{-10}$ /day (See Notes 1 and 2.)
Frequency Stability (1 second averaging)	$5 \times 10^{-12}$ Root Allan Variance (RAV) @ 1 sec
Waveform	Sinewave, > 1 Volt pk-pk into a 50Ω load
Harmonic Distortion (Typical)	< -25 dBc (typical)
Non-Harmonic Signals (Typical)	< -60 dBc (typical)
Source Impedance (nominal)	50Ω
Coupling	AC
<b>1 PPS Output</b>	
Jitter of leading edge	Pulse-to-pulse jitter of leading edge: <750 ps with at least one satellite in view.
Accumulated time error	< 8.6 μs per day unlocked, for 24 hours. (See Notes 1 and 2.)
Waveform—Pulse width	26 μs -2.4 Volts minimum into 50Ω load (TTL compatible)
Time Accuracy	< 110 ns with respect to UTC with Selective Availability on — 95% probability when unit is properly installed, calibrated, and locked to GPS.
<b>2048 kbps Output (Options 220, 221, 222, 270, 271, 272)</b>	
Output Type	2048 kbps, framed per ITU-T G.703, Table 6; all 1 s, CCS, CAS, CRC4 switch selectable AMI (HDB3)
Waveform	Options 270, 271, 272: $2.37 \pm 0.237$ Volts peak (75Ω) Options 220, 221, 222: $3.0 \pm 0.3$ Volts peak (120Ω)
Wave Shape	Rectangular, pulse width 244 ns $\pm$ 25 ns, pulse interval 488 ns per ITU-T G.703, Table 6, Fig 15
Impedance	Options 270, 271, 272: 75Ω unbalanced Options 220, 221, 222: 120Ω balanced
<b>2048 kHz Output</b>	
Output Type	2048 kHz per ITU-T G.703, Table 10, Fig 21
Wave Form	75Ω : 1.5 Volts peak maximum, 0.75 Volts peak minimum
Wave Shape	Square Wave
Impedance	75Ω unbalanced

**Introduction****Specifications and Characteristics for Alarm Output**

<b>Description</b>	<b>Specification</b>
Alarms available	Critical, Major, and Minor; alarm causes are selectively assignable to alarms.
Alarm Relay Contact Ratings:	
Switching Power	60 W maximum
Switching Voltage	30 Vac or 60 Vdc maximum
Switching Current	2 A maximum
Alarm Relays (6):	
3 Critical, Major, Minor	Normally open and normally closed contacts
3 Critical, Major, Minor with alarm cutoff	Normally open and normally closed contacts
Alarm causes	Power failure, Output failure, Oscillator failure, Synthesizer failure, Loss of GPS signal (holdover), Self-test failure

**Commands/Status**

Commands and status returns are compatible with TL1 as specified in GR-833-CORE, TR-NWT-000834, and GR-199-CORE.

**Rack Mount Shelf Specifications and Characteristics****55310A GPS NEBS/EIA Rack Mount Shelf—100Ω Balanced Outputs  
(Used with 55300A Options 104, 105)**

<b>Description</b>	<b>Specification</b>
Rack Mount Configuration	Compatible with standard NEBS 23" or EIA 19" racks
Size — W × H × D — in (mm)	16.73 × 3.35 × 11.19 (425 × 85.1 × 284.3)
Weight of Rack Mount Shelf	4.4 lbs (2.0 kg)
Power Requirements	Dual redundant power inputs (A and B) –48 Vdc nominal
Connectors on back of rack mount:	
10 MHz Output	BNC, 50Ω nominal
1 PPS	BNC, 50Ω nominal
TOD IRIG-B	BNC, 50Ω nominal
1544 kHz Output	BNC, 75Ω nominal
GPS Antenna	Type N (female)
Power Inputs	Augat Snap-on pressure clamp
1544 kbps Output	Wire-wrap pins, 100Ω balanced
1 PPS (RS 422)	Wire-wrap pins
Alarms	Wire-wrap pins
Time of Day (TOD)	RS-232 DE-9P DTE, male (1 PPS DCD included)
Remote Access Port	RS-232 DB-25S DTE, female

## Introduction

**55320A GPS ETSI Rack Mount Shelf—75Ω Unbalanced Outputs  
(Used for 55300A Options 270, 271, 272)**

Description	Specification
Rack Mount Configuration	Compatible with standard ETSI 535 mm or EIA 19" racks
Size—W × H × D—mm (in)	425 × 168.4 × 257.3 (16.73 × 6.63 × 10.13)
Weight of Rack Mount	6.1 lbs (2.8 kg)
Power Requirements	Dual redundant power inputs (A and B) –48 Vdc nominal
Connectors on Rack Mount:	
10 MHz Output	BNC, 50Ω nominal
1 PPS	BNC, 50Ω nominal
TOD IRIG-B	BNC, 50Ω nominal
2048 kHz Output	BNC, 75Ω nominal
GPS Antenna	Type N (female)
Power Inputs	Augat Snap-on pressure clamp
2048 kbps Output	BNC 75Ω unbalanced
1 PPS	BNC (2) RS-422 (differential pair)
Alarms	DB-25P, male
Time of Day (TOD)	RS-232 DE-9P DTE, male (1 PPS DCD included)
Remote Access Port	RS-232 DB-25S DTE, female

**55322A GPS ETSI Rack Mount Shelf—120Ω Balanced Outputs  
(Used for 55300A Options 220, 221, 222)**

Description	Specification
Rack Mount Configuration	Compatible with standard ETSI 535 mm or EIA 19" racks
Size—W × H × D—mm (in)	425 × 168.4 × 257.3 (16.73 × 6.63 × 10.13)
Weight of Rack Mount	6.1 lbs (2.8 kg)
Power Requirements	Dual redundant power inputs (A and B) –48 Vdc nominal
Connectors on Shelf:	
10 MHz Output	BNC, 50Ω nominal
1 PPS	BNC, 50Ω nominal
TOD IRIG-B	BNC, 50Ω nominal
2048 kHz Output	BNC, 75Ω nominal
GPS Antenna	Type N (female)
Power Inputs	Augat Snap-on pressure clamp
2048 kbps Output	DE-9S, 120Ω balanced
1 PPS	DE-9S (2) RS-422
Alarms	DB-25P, male
Time of Day (TOD)	RS-232 DE-9P, DTE male (1 PPS DCD included)
Remote Access Port	RS-232 DB-25S DTE, female

**Introduction****Environmental Specifications**

<b>Description</b>	<b>Specification</b>
Power Requirements	-48 Vdc nominal, 700 ma startup; 350 ma steady state -39 to -60 Vdc operating range, -47 Vdc required to start (for units with serial prefixes below 3812A)  OR  -37 to -60 Vdc operating range, -46 Vdc required to start (for units with serial prefixes 3812A and above)
Temperature Range	Operating: 0°C to +50°C Storage: -40°C to +70°C

**Specifications for GPS Antenna & Antenna Cable**

<b>Description</b>	<b>Specification</b>
Active Antenna	30 dB (typical) active gain with dielectric filter
Antenna Power Requirements	5 V (nominal); 50 ma maximum (supplied by 55300A)
Temperature Range	Operating: -30°C to +80°C Storage: -40°C to +85°C
Antenna Cable Types	RG-213 cable is recommended for lengths up to 175 ft (53 m). A line amplifier is required with RG-213 cable when lengths exceed 175 ft (53 m). LMR-400 cable is recommended for lengths greater than 175 ft (53 m); it is a lower loss cable. A line amplifier is required with LMR-400 for distances greater than 377 ft (110 m).
Cable connectors	Type N male connector at the 55300A Type TNC male at the antenna

## Introduction

### Antenna Installation

For optimum performance, the antenna should be installed in a location which gives it a clear view of the entire sky. All GPS receivers require at least four satellites to be visible in order to determine latitude, longitude, elevation, and time.

Up to 377 feet (110 meters) of LMR-400 cable may be used between the antenna and the 55300A before an antenna line amplifier is required (if using RG-213 cable, one is needed at 175 feet/53 meters). For applications which require longer cable runs, please consult your Symmetricom representative. Lower loss cable and antenna line amplifiers are available to meet most needs.

### Bellcore CLEI # BSMTBBOARA and CPR # 134051

#### Accessories Available:

58504B	GPS Antenna
58510A	Environmental Cover/Ground Plane (for GPS Antenna)
58513A	Antenna Assembly (Assembled unit includes: 58504A GPS Antenna, 4-foot cable, 58510A cover and ground plane, and 1-foot stainless steel mast for mounting.)
58505B	Lightning Arrester. Two recommended for cable distance from lightning arrester to receiver module greater than 100 ft (30 m).
58509A	Antenna Line Amplifier (recommended for distances greater than 175 ft/53 m for RG-213 cable, 377 ft/110 m for LMR-400 cable)

Note: The 58505B Lightning Arrester and the 58509A Line Amplifier may require the addition or the mixing of various lengths of cables.

### Antenna Cables and Configuration Guide

For details concerning cables, connectors, and other accessories see:

**Designing Your GPS Antenna System—Configuration Guide**  
(Available from your local Sales Office)



---

## Chapter Contents

This chapter provides troubleshooting, disassembly and reassembly, exchange, and replaceable parts information.

This chapter is organized as follows:

- Pre-Troubleshooting Information page 6-3
  - Safety Considerations page 6-3
  - Recommended Test Equipment page 6-3
  - Repair Considerations page 6-4
  - After Service Considerations page 6-4
  - Assembly Identification and Location page 6-5
- Troubleshooting the 55300A page 6-7
  - Troubleshooting Strategy page 6-7
  - To Isolate Problems Using SatStat Health Monitor and Diagnostic Log Features page 6-8
  - To Isolate GPS Antenna and Accessories page 6-10
  - To Isolate A1 Main Board and A2 DC-DC Power Supply Board page 6-12
  - Switch or Jumper Wire Configuration Check page 6-17
- Replacing Assemblies page 6-23
  - Tools Required page 6-23
  - To Remove Module From Rack Mount Shelf page 6-23
  - To Remove A1 Main Board Assembly page 6-24
  - To Remove A2 DC-DC Power Supply Assembly page 6-26
- Testing Operation After Repairs page 6-28
  - Overview of the Diagnostic LEDs page 6-28
  - To Perform the Power-Up Diagnostic Selftest page 6-30
- Replaceable Parts page 6-31
  - Exchange Assemblies page 6-31
  - Reference Designations page 6-31
  - About the Replaceable Parts List page 6-31
  - How To Order A Part page 6-32
  - Chassis Parts and Hardware page 6-33
  - Replaceable Parts List page 6-33
- Backdating page 6-34



---

## Pre-Troubleshooting Information

This section contains the following pertinent troubleshooting information:

- Safety Considerations
- Recommended Test Equipment
- Repair Considerations
- After Service Considerations
- Assembly Identification and Location

### **Safety Considerations**

Although this instrument has been designed in accordance with international safety standards, this guide contains information, cautions, and warnings which must be followed to ensure safe operation and to retain the instrument in a safe condition. Service instructions, and adjustment procedures requiring removal of the instrument cover, are for use by service-trained personnel only. To avoid dangerous electric shock, do not perform any servicing or make any adjustments with the cover removed, unless qualified to do so.

---

#### **WARNING**

**BEFORE APPLYING DC POWER, THE INSTRUMENT AND ALL PROTECTIVE EARTH TERMINALS, EXTENSION CORDS, AUTO TRANSFORMERS, AND DEVICES CONNECTED TO THE INSTRUMENT SHOULD BE CONNECTED TO A PROTECTIVE EARTH GROUNDED SOCKET.**

Any maintenance and repair of the opened instrument under voltage should be avoided as much as possible and, if necessary, should be carried out only by a skilled person who is aware of the hazards involved.

for example, fire and electric shock).

### **Recommended Test Equipment**

**Test equipment recommended for testing and troubleshooting the 55300A is listed in Chapter 2, “Acceptance Test.”** Substitute equipment may be used if it meets or exceeds the required characteristics listed in Table 2-2.

## Pre-Troubleshooting Information

### Repair Considerations

#### *Electrostatic Discharge*

Electronic components and assemblies in the 55300A can be permanently degraded or damaged by electrostatic discharge. Use the following precautions when servicing the instrument:

- 1 ENSURE that static-sensitive devices or assemblies are serviced at static-safe work stations providing proper grounding for service personnel.
- 2 ENSURE that static-sensitive devices or assemblies are stored in static shielding bags or containers.
- 3 DO NOT wear clothing subject to static-charge buildup, such as wool or synthetic materials.
- 4 DO NOT handle components or assemblies in carpeted areas.
- 5 DO NOT remove an assembly or component from its static shielding protection until you are ready to install it.
- 6 AVOID touching component leads. (Handle by packaging only.)

#### *Disassembly and Reassembly Specifics*

Refer to the section titled “Replacing Assemblies” for complete disassembly and reassembly details. Refer to the section titled “Replaceable Parts” for the parts list.

### After Service Considerations

After replacement of any assembly or module, refer to the section titled “Testing Operation After Repairs” starting on page 6-28.

**Pre-Troubleshooting Information****Assembly Identification and Location**

The assembly number, name and part number of the 55300A assemblies are listed in Table 6-1. Figure 6-1 illustrates the replaceable assemblies and cables in the 55300A.

**Table 6-1. 55300A Assembly Identification**

<b>Assembly Name</b>	<b>Part No.</b>	<b>Exchange Part No.*</b>
A1 Main Board with oven oscillator (Option 104, 105)		55300-69101
A1 Main Board with oven oscillator (Option 220, 221, 270, 271, and 272)		55300-69102
A2 DC-DC Power Supply	58503-60003	no exchange
W1 -48 Vdc Cable	55300-60202	no exchange
W2 Main Board Regulated DC Supply Cable	58503-60203	no exchange

\* Exchange part availability is subject to change without notice.

Chapter 6 Maintenance  
Pre-Troubleshooting Information

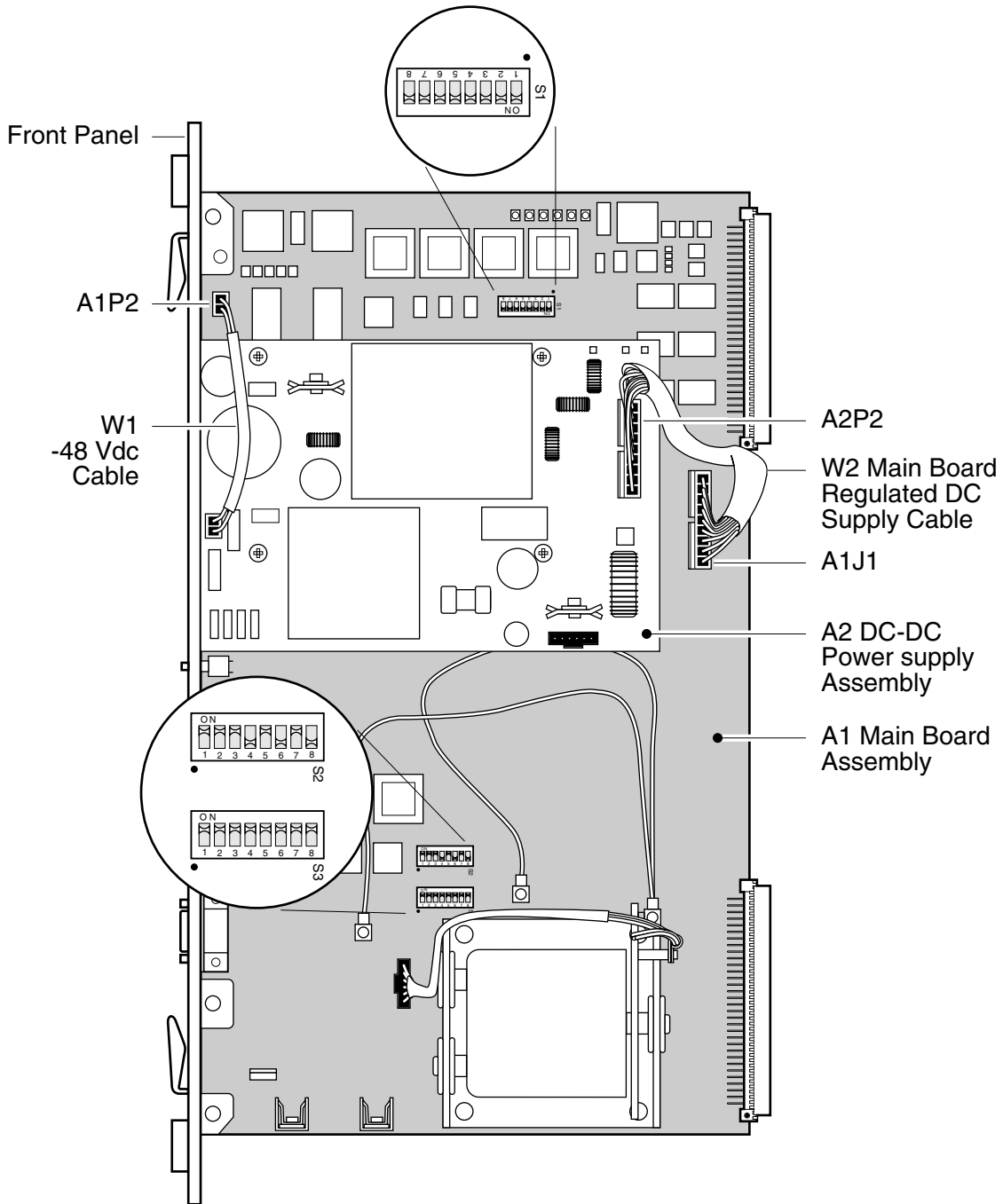

Figure 6-1. Instrument Top Internal View

## Troubleshooting the 55300A

### **Troubleshooting Strategy**

The overall troubleshooting strategy is to:

- use the –48 Vdc power supply check procedure if your unit is dead. (The power supply check procedure is in the section titled “To Isolate A1 Main Board and A2 DC-DC Power Supply Board” on page 6-12.)
- use the HEALTH MONITOR section of the SatStat software or program (59551-13401) to aid in determining the possible origin of hardware problems.
- use the SYNCHRONIZATION section of the SatStat program to see if the unit is locking to GPS or to internal reference oscillator (holdover operation).
- use the Diagnostic Log of SatStat program to discover intermittent alarm problems.
- use conventional troubleshooting techniques to isolate between the GPS antenna (and accessories), A1 Main Board Assembly, and A2 DC-DC Power Supply Assembly to determine which one is faulty.

## To Isolate Problems Using SatStat Health Monitor and Diagnostic Log Features

---

**NOTE**

---

If you cannot communicate with the unit using SatStat, ensure that you are using the **TIME OF DAY** port, and NOT the **REMOTE ACCESS PORT** or **PORT 1**.

Three troubleshooting features of SatStat program (59551-13401), which do not require that you remove the 55300A module from its rack mount shelf, can aid in isolating some problems. These features (Health Monitor, Synchronization, and Diagnostic Log) are discussed in the following sections.

### *Using the HEALTH MONITOR Section of the Receiver Status Screen*

Review the HEALTH MONITOR section of the Receiver Status screen, which is located at the bottom of the screen (see figure below). The data in this area can be very helpful in isolating trouble. Refer to the section titled “HEALTH MONITOR Section of the Screen” in Chapter 4, “Using the Receiver Status Screen,” of this guide for specifics.

```
----- Receiver Status -----
SYNCHRONIZATION ..... [ Outputs Valid ]
SmartClock Mode _____ Reference Outputs _____
>> Locked to GPS          TFOM      3          FFOM      0
  Recovery                1PPS TI +7.2 ns relative to GPS
  Holdover                HOLD THR 1.000 us
  Power-up                Holdover Uncertainty _____
                          Predict  49.0 us/initial 24 hrs

ACQUISITION ..... [GPS 1PPS Valid]
Tracking: 6 _____ Not Tracking: 1 _____
PRN  El  Az  SS  PRN  El  Az          Time _____ +1 leap second pending
  2  49 243 168   14 11  82          UTC      23:59:59   31 Dec 1995
 16  24 282 125          GPS 1PPS Synchronized to UTC
 18  38 154 132          ANT DLY   120 ns
 19  65  52 168          Position _____
 27  62 327 246          MODE      Survey: 17.5% complete
 31  34  61 133          AVG LAT  N  37:19:32.264
                          AVG LON  W 121:59:52.112
                          AVG HGT           +41.86 m (MSL)
ELEV MASK 10 deg          HEALTH MONITOR ..... [ OK ]
Self Test: OK Int Pwr: OK Oven Pwr: OK  OCXO: OK  EFC: OK  GPS Rcv: OK
```

If an **Err** indication is displayed for the **Self Test:**, **Int Pwr:**, **Oven Pwr:**, **OCXO:**, or **EFC:** portions of the HEALTH MONITOR, then perform the isolation procedure provided in the section titled “To Isolate A1 Main Board and A2 DC-DC Power Supply Board” (*starting on page 6-12*).

## Troubleshooting the 55300A

If the and **Err** indication is displayed for the **GPS Rcv:** portion of the HEALTH MONITOR, then perform the isolation procedure provided in the section titled “To Isolate GPS Antenna and Accessories” (*starting on page 6-10*).

### ***Using the SYNCHRONIZATION Section of the Receiver Status Screen***

Review the SmartClock Mode quadrant of the SYNCHRONIZATION section of the SatStat program.

If the unit continues to operate in the holdover mode, then perform the isolation procedure provided in the section titled “To Isolate GPS Antenna and Accessories” (*starting on page 6-10*).

### ***Using the Diagnostic Log of SatStat Program***

In SatStat, select the **Control & Query** window (which usually will be partially hidden beneath the main **Hewlett-Packard SatStat** window) by clicking on its visible boundary. Select **Query** followed by **Get Diagnostic Log**, then click on **Send Cmd** button. After a few seconds, log information will be displayed. Review the log to aid in isolating failure.

The diagnostic log can help you solve intermittent alarm problems.

The Diagnostic Log is one way to obtain Receiver status.

The following activities and events are recorded in the diagnostic log:

- power-on sequence,
- automatic or manual transitions between locked, and holdover,
- automatic or manual transitions between position survey and position hold operation,
- alarm indications, and
- self-test failures.

Each entry is date-and-time tagged. The log entries are stored in non-volatile memory so all data remains valid even if power is lost.

---

**CAUTION**

---

After correcting an alarm problem, clear the log by selecting **Control**, and then **Alarm Clear and Show Cause**.

**Troubleshooting the 55300A****To Isolate GPS Antenna and Accessories**

- 1 Before removing the 55300A module from the Rack Mount Shelf, try using the SatStat program or software (59551-13401) to verify that the 55300A/55310A/55320A/55322A GPS Telecom Primary Reference Source is tracking at least one satellite (after GPS lock).

If the unit is not tracking at least one satellite, verify that the GPS antenna is being properly driven by performing step 2.

- 2 Measure the +5V out of the **GPS ANTENNA** input connector by performing the following steps (**Note:** The 55300A supplies the +5V that drives the GPS antenna and accessories.):
  - a. Disconnect the antenna cable from the **GPS ANTENNA** input connector.
  - b. Using a BNC cable, connect a DMM or digital voltmeter to the **GPS ANTENNA** input connector as shown in Figure 6-2A.

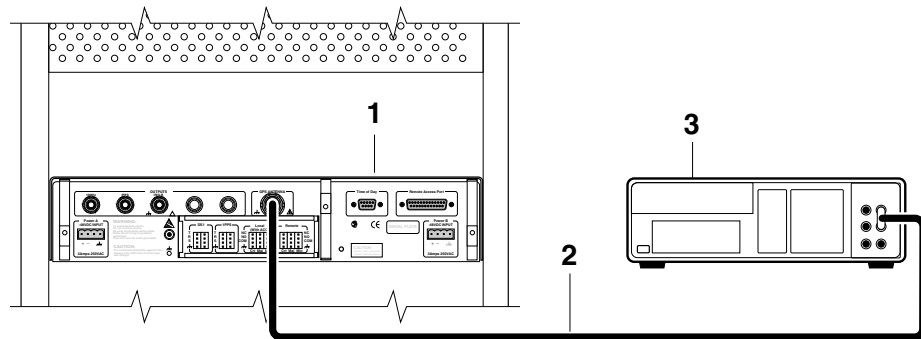

1 55300A/55310A

3 DMM or voltmeter

2 BNC cable to DMM or voltmeter

**Figure 6-2A. Measuring +5 Volts Across GPS ANTENNA Input (NEBS/EIA Rack Mount Shelf is shown)**

- c. Observe a reading of a little less than +5 Volts.

If the unit's +5 Volts is okay, go to step 3.

If the unit's +5 Volts is incorrect, then perform the isolation procedure provided in the section titled "To Isolate A1 Main Board and A2 DC-DC Power Supply Board" (*starting on page 6-12*).



**Troubleshooting the 55300A**

- 3 Connect a Tee connector to the **GPS ANTENNA** input connector, and connect the antenna cable to one end of the Tee connector as shown in Figure 6-2B.

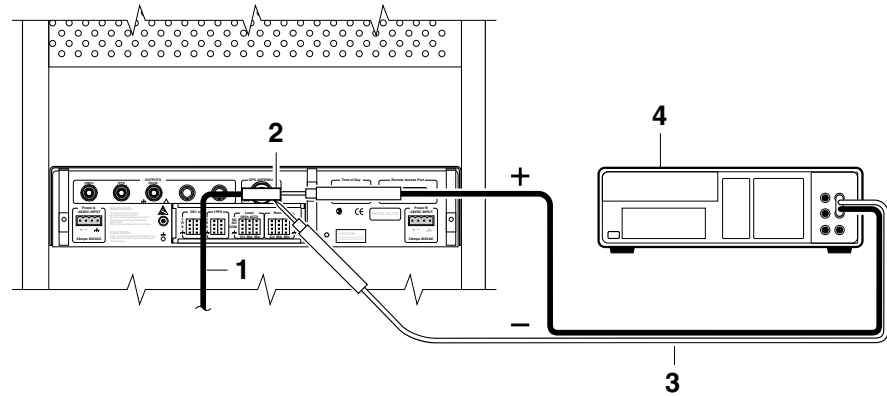

- |                        |                          |
|------------------------|--------------------------|
| 1 Cable of GPS Antenna | 3 DMM or voltmeter leads |
| 2 Tee connector        | 4 DMM or voltmeter       |

**Figure 6-2B. Measuring +5 Volts Across GPS ANTENNA Input With Antenna System Connected (NEBS/EIA Rack Mount Shelf is shown)**

---

**CAUTION**

---

Be very careful to not short the positive and negative leads of the voltmeter when making the measurement in step 4 below.

- 4 From the other end of the Tee connector, using voltmeter leads, measure the +5 Volts between the center conductor and shell.

If 0 Volts is present, it indicates a short in the GPS antenna system. Use conventional troubleshooting isolation techniques to determine problem.

If your reading is approximately +5 Volts, go to step 5.

- 5 Disconnect the GPS antenna cable end that connects directly to the TNC connector of the GPS antenna. Now, measure between the center conductor and shell of this cable's TNC connector.

If it measures a lot less than +5V, find where the voltage loss occurs.  
*Hint:* The problem could be a faulty lightning arrester, or line amplifier, or combination of these.

If it measures +5V, replace the GPS antenna.

**Troubleshooting the 55300A**

---

**NOTE**

---

Before performing the next step, remove the Tee connector and restore antenna connection as loading of the Tee connector will prevent proper reception of the GPS signal by the antenna.

- 6 After the antenna connection has been verified, disconnect and reconnect the external dc power on the unit to facilitate rapid recovery from the fault.

**To Isolate A1 Main Board and A2 DC-DC Power Supply Board**

- 1 Remove the 55300A from the rack mount shelf as shown in Figure 6-7 on page 6-24 of the section titled “To Remove Module From Rack Mount Shelf.”
- 2 Turn on the HP 6633A (or equivalent) DC Power Supply.
- 3 Set the HP 6633A (or equivalent) DC Power Supply to output 48 Vdc and 2 amps of current.

---

**NOTE**

---

The power supply’s output leads will be reversed at the connection to the 55300A in steps 5 and 6 to get a negative input voltage (-48 Vdc) output.

- 4 Using a DMM or voltmeter, verify that the voltmeter reads 48 Vdc  $\pm 5V$ .
- 5 Connect the negative lead of the HP 6633A DC Power Supply (or equivalent) to pin C1 of the 96-pin connector that is near A2 DC-DC Power Supply Assembly as shown in Figure 6-3.

Chapter 6 Maintenance  
Troubleshooting the 55300A

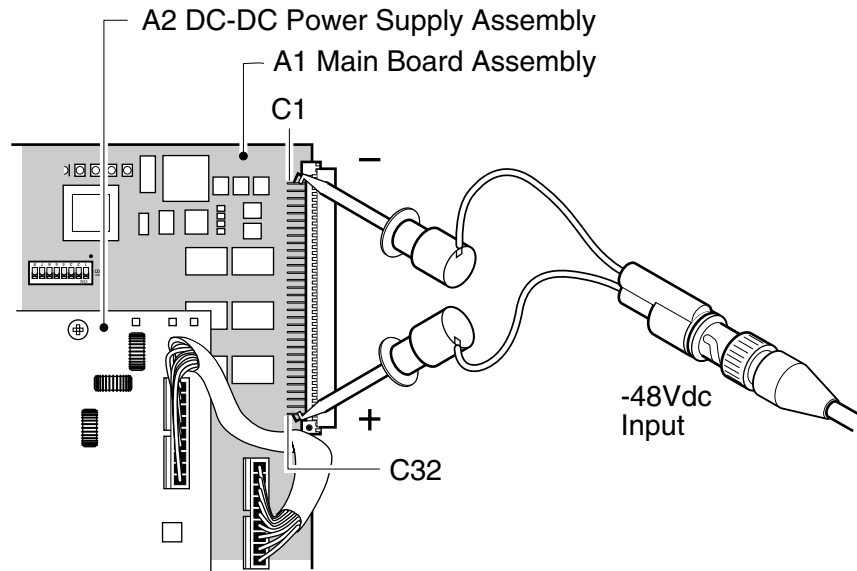

**Figure 6-3. -48 Vdc Check**

- 6 Connect the positive lead of the dc power supply to pin C32 of the 96-pin connector as shown in Figure 6-3.
- 7 Measure the input voltage at C1 and C32 by connecting the positive lead of the DMM or voltmeter to C1 and the negative lead of the voltmeter to C32.
- 8 Verify that the voltmeter reads 48 Vdc  $\pm$ 5V.

If the voltage is correct, go to step 9.

If the voltage is incorrect, go to step 10 to check cable W1.

**Troubleshooting the 55300A**

- 9 From the bottom side of the main board assembly, shown in Figure 6-4, measure the +5V, -15V, and +15V regulated voltages on J1, using a voltmeter. These voltages are outputted from A2 DC-DC Power Supply Assembly.

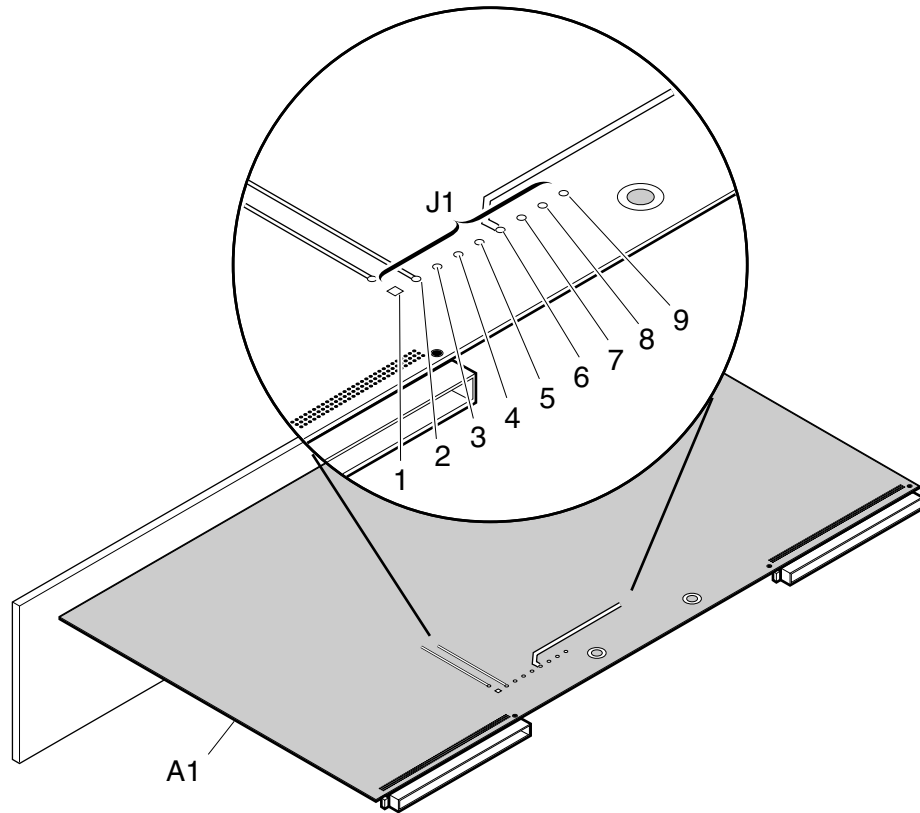

**Figure 6-4. A2 DC-DC Power Supply Outputs at Testpoint Locations on A1 Main Board Assembly J1 (Bottom View)**

- a. Verify that the voltages in Table 6-2 match the voltages measured on connector J1 of A1 Main Board Assembly.

---

**CAUTION**

---

BE CAREFUL to NOT short the supply-side lead of the voltmeter to the chassis when probing at the testpoints shown in Figure 6-4.

Table 6-2 lists A2 power supply's voltages, the corresponding wire color, and the tolerances.

**Table 6-2. A2 Power Supply Voltages**

Item in Figure 6-4	Wire Color	Voltage	Tolerance
1	Red	+5.0 V	+4.8 V to +5.2 V
2	Red	+5.0 V	+4.8 V to +5.2 V
3	Black	0.0 V	
4	Black	0.0 V	
5	Yellow	+15.0 V	+14.5 V to +15.5 V
6	Black	0.0 V	
7	Blue	-15.0 V	-15.5 V to -14.5 V
8	Purple	not used	
9	Green	not used	

- b.** If all voltages check correct, replace A1 Main Board Assembly by following the procedure in the section titled “To Isolate A1 Main Board and A2 DC-DC Power Supply Board” on page 6-12.
  - c.** If one voltage is incorrect, replace A2 DC-DC Power Supply Assembly by following the procedure in the section titled “To Remove A2 DC-DC Power Supply Assembly” on page 6-26.
  - d.** If all voltages check incorrect, then proceed to step 10 to check cable W1.
- 10** Remove or turn off the -48 Vdc external supply. Using your hand, pull up on each connector end of cable W1 (the small cable, 55300-60202) to disconnect it from A2 DC-DC Power Supply Assembly as shown in Figure 6-5.

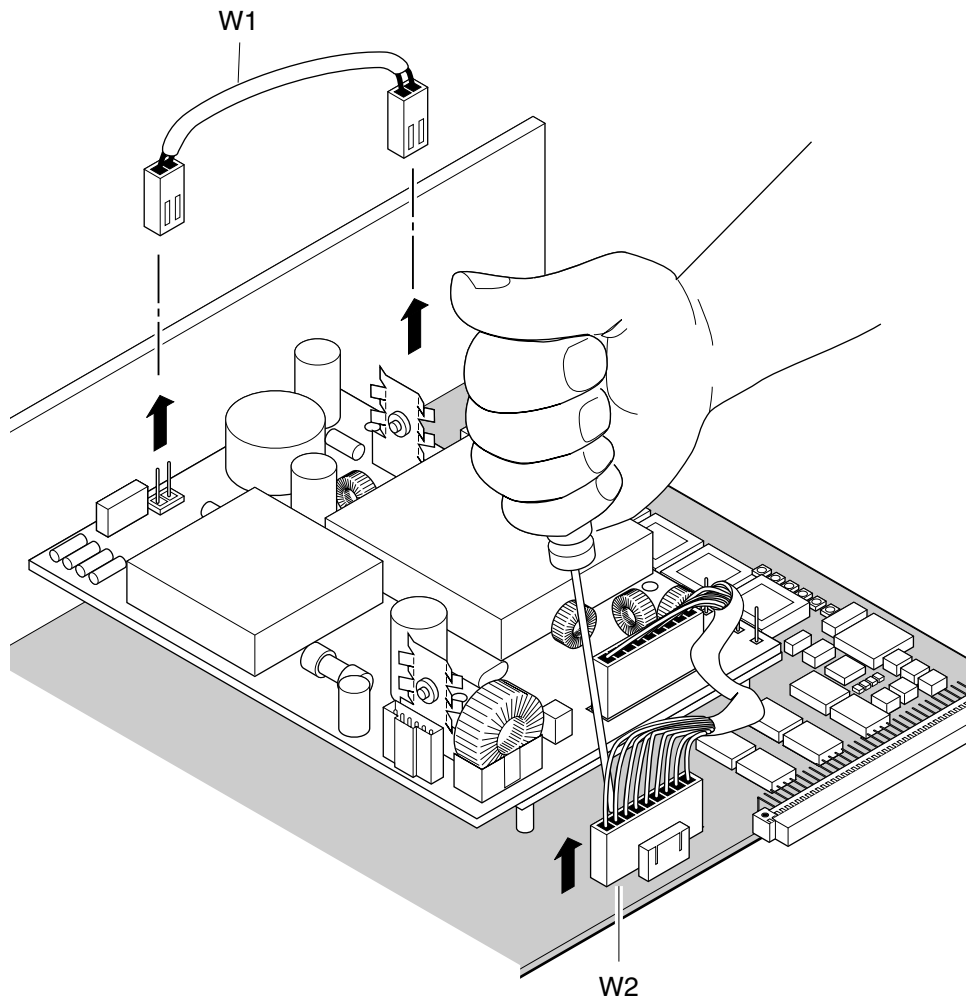

**Figure 6-5. Disconnecting W1 –48 Vdc Cable**

- 11** With cable W1 removed, perform a continuity check on it using a DMM or ohmmeter.
  - a.** If cable W1 checks incorrect, replace W1.
  - b.** If cable W1 checks okay, reconnect it and proceed to step 12.
- 12** Using a medium flat-head screw driver, disconnect cable W2 (from A2 DC-DC Power Supply Assembly as shown in Figure 6-5).
- 13** Perform a continuity check on cable W2 (the large cable, 58503-60203).

**Troubleshooting the 55300A**

- a. If cable W2 checks incorrect, replace cable W2.
- b. If cable W2 checks okay, replace A2 DC-DC Power Supply Assembly by following the procedure in the section titled “To Remove A2 DC-DC Power Supply Assembly” on page 6-26 in this chapter.

**Switch or Jumper Wire Configuration Check****NOTE**

Depending on when your Revision D Main Board Assembly was manufactured, switches S2 and S3 could be dip switches or jumper wires. A jumper wire that is installed is equivalent to a closed (ON) switch. No jumper wire installed is equivalent to an opened (OFF) switch. In this section all mentions or listing of the bit switches for S2 and S3 also apply to the corresponding jumper wires. See Figure 6-6.

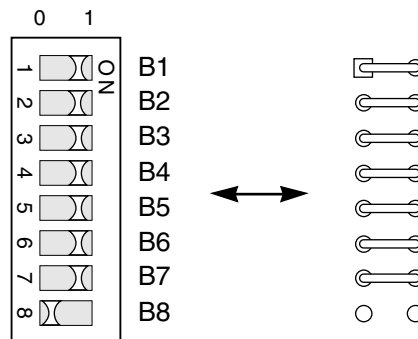

**Figure 6-6. Example of DIP Switches Versus Jumper Wires**

***Exchanged A1 Main Boards Are Configured for Option 104 or Option 271***

*DIP Switches S2 and S3 on the exchanged 55300-69101 (Option 104, 105) A1 Main Board Assembly are factory-default configured for Option 104. However, if your desired configuration is an Option 105 unit, only S2 needs to be re-configured (since S3 configuration is identical for both options 104 and 105). Refer to the section titled “S2 and S3 Switch Configuration Summary” for switch setting information.*

*DIP switches S2 and S3 on the exchanged 55300-69102 (Options 220, 221, 270, 271, and 272) A1 Main Board Assembly are factory-default configured for Option 271. Set appropriate bit switches of S2 and S3 to configure the desired option. Refer to the section titled “S2 and S3 Switch Configuration Summary” for switch setting information.*

**Troubleshooting the 55300A**

**Before installing your exchanged A1 Main Board Assembly, verify that the switches or jumper wires of S2 and S3 are set correctly for your 55300A option.**

If the switch settings are incorrect, set switches S2 and S3 as indicated in tables 6-5A/6-5B and 6-6A/6-6B. If you still have a problem, call your local Symmetricom Service Center.

If the switch settings are correct, install the main board assembly by performing the steps given in “To Remove A1 Main Board Assembly” in reverse order.

***S2 and S3 Switch Configuration Summary***

Tables 6-3 and 6-4 lists the setting of the 8-bit switches S2 and S3 for each of the telecom option outputs.

Tables 6-5A/6-5B through 6-6A/6-6B shows switches in their proper configurations or settings, and provide a description of each bit switch of S2 and S3 within the different switch configurations.

The combination of the tables 6-3/6-4 and tables 6-5/6-6 provide complete S2 and S3 switch configuration information.

**Table 6-3. Summary of S2 Switch Settings for Each Option**

S2 Settings								
Option Number	1	2	3	4	5	6	7	8
104	*	ON	ON	ON	ON	ON	ON	ON
105		ON	ON	ON	ON	ON	OFF	ON
220		ON	ON	OFF	ON	OFF	ON	OFF
221		ON	ON	ON	ON	OFF	ON	OFF
222		ON	ON	OFF	OFF	OFF	ON	OFF
270		ON	ON	OFF	ON	OFF	ON	OFF
271		ON	ON	ON	ON	OFF	ON	OFF
272		ON	ON	OFF	OFF	OFF	ON	OFF

\* The shading denotes unused switch section(s).



Chapter 6 Maintenance  
**Troubleshooting the 55300A**

**Table 6-4. Summary of S3 Switch Settings for Each Option**

S3 Settings								
Option Number	1	2	3	4	5	6	7	8
104	ON	OFF	OFF	ON	OFF	OFF	*	
105	ON	OFF	OFF	ON	OFF	OFF		
220	ON	ON	OFF	ON	ON	OFF		
221	ON	ON	OFF	ON	ON	OFF		
222	ON	ON	OFF	ON	ON	OFF		
270	ON	ON	ON	ON	ON	ON		
271	ON	ON	ON	ON	ON	ON		
272	ON	ON	ON	ON	ON	ON		

\* The shading denotes unused switch section(s).

**Table 6-5A. S2 Options 104 and 105 (1544 KHz, T1) Switch Settings**

S2 (Option 104)      S2 (Option 105)			
		0	1
S2 Switch Position	S2 Functions	ON (1)	OFF (0)
B1 (Bit 1)	*		
B2 (Bit 2)	S-bit	internal	external
B3 (Bit 3)	Mode	hardware	host
B4 (Bit 4)	Code	AMI	B8ZS
B5 (Bit 5)	0 Sup	transp	Bit 7 stuff
B6 (Bit 6)	Xmt Yellow	disabled	enabled
B7 (Bit 7)	Framing	D4	ESF
B8 (Bit 8)	Frequency	T1	E1

\* The shading denotes unused switch section(s).

Chapter 6 Maintenance  
**Troubleshooting the 55300A**

**Table 6-5B. Output Cable Length Switch (S3) for DS1 Options 104 and 105**

S3 (Options 104 and 105)

<b>S3 Bit Switches for 55310A DS1 A and B Wire-Wrap Outputs</b>	<b>Output Cable Length (Feet)</b>				
	less than 134 ft.	134 ft.–266 ft.	267 ft.–399 ft.	400 ft.–533 ft.	534 ft.–655 ft.
B1 (Bit 1)	ON	OFF	OFF	OFF	OFF
B2 (Bit 2)	OFF	ON	ON	OFF	OFF
B3 (Bit 3)	OFF	ON	OFF	ON	OFF
B4 (Bit 4)	ON	OFF	OFF	OFF	OFF
B5 (Bit 5)	OFF	ON	ON	OFF	OFF
B6 (Bit 6)	OFF	ON	OFF	ON	OFF
B7 (Bit 7)	*				
B8 (Bit 8)					

\* The shading denotes unused switch section(s).

Chapter 6 Maintenance  
**Troubleshooting the 55300A**

**Table 6-6A. S2 Options 220, 221, 222, 270, 271, and 272 Switch Settings**

S2 Switch Position	S2 Functions	ON (1)	OFF (0)
B1 (Bit 1)	*		
B2 (Bit 2)	TRA	normal	enable
B3 (Bit 3)	Mode	hardware	host
B4 (Bit 4)	CAS	ON	OFF
B5 (Bit 5)	CRC 4	OFF	ON
B6 (Bit 6)	Code	AMI	HDB3
B7 (Bit 7)	TDMA	disabled	enabled
B8 (Bit 8)	Frequency	T1	E1

\* The shading denotes unused switch section(s).

**Troubleshooting the 55300A**

**Table 6-6B. Impedance Switch (S3) for 2048 kbps A and B Outputs for Options 220, 221,222, 270, 271, and 272**

S3 (Options 220, 221, and 222)		S3 (Options 270, 271, and 272)	
	0 1		0 1
2048 kbps A (120Ω)		2048 kbps A (75Ω)	
2048 kbps B (120Ω)		2048 kbps B (75Ω)	

S3 Switch Position	120Ω Balanced	75Ω Unbalanced
B1 (Bit 1)	ON	ON
B2 (Bit 2)	ON	ON
B3 (Bit 3)	OFF	ON
B4 (Bit 4)	ON	ON
B5 (Bit 5)	ON	ON
B6 (Bit 6)	OFF	ON
B7 (Bit 7)	*	
B8 (Bit 8)		

\* The shading denotes unused switch section(s).

## Replacing Assemblies

This section contains instructions for removing major assemblies of the 55300A module. To install an assembly, reverse the removal instructions. Before working on the module, read the section titled “Safety Considerations” on page 6-3 of this chapter, and the safety considerations section in the Certification and Warranty page, which follows the title page of this guide.

### **Tools Required**

- TORX® T9 driver—for front panel lever screws (H3)
- TORX® T10 driver—for chassis ground screw (H4)
- TORX® T15 driver—for A1 Main Board and A2 Power Supply screws (H1, H2)
- Medium flat-blade screwdriver—for removing cable W2
- ESD (electrostatic discharge) strap and area

### **To Remove Module From Rack Mount Shelf**

Loosen the screws, pull out the levers, and remove unit from the shelf as shown in Figure 6-7.

## Replacing Assemblies

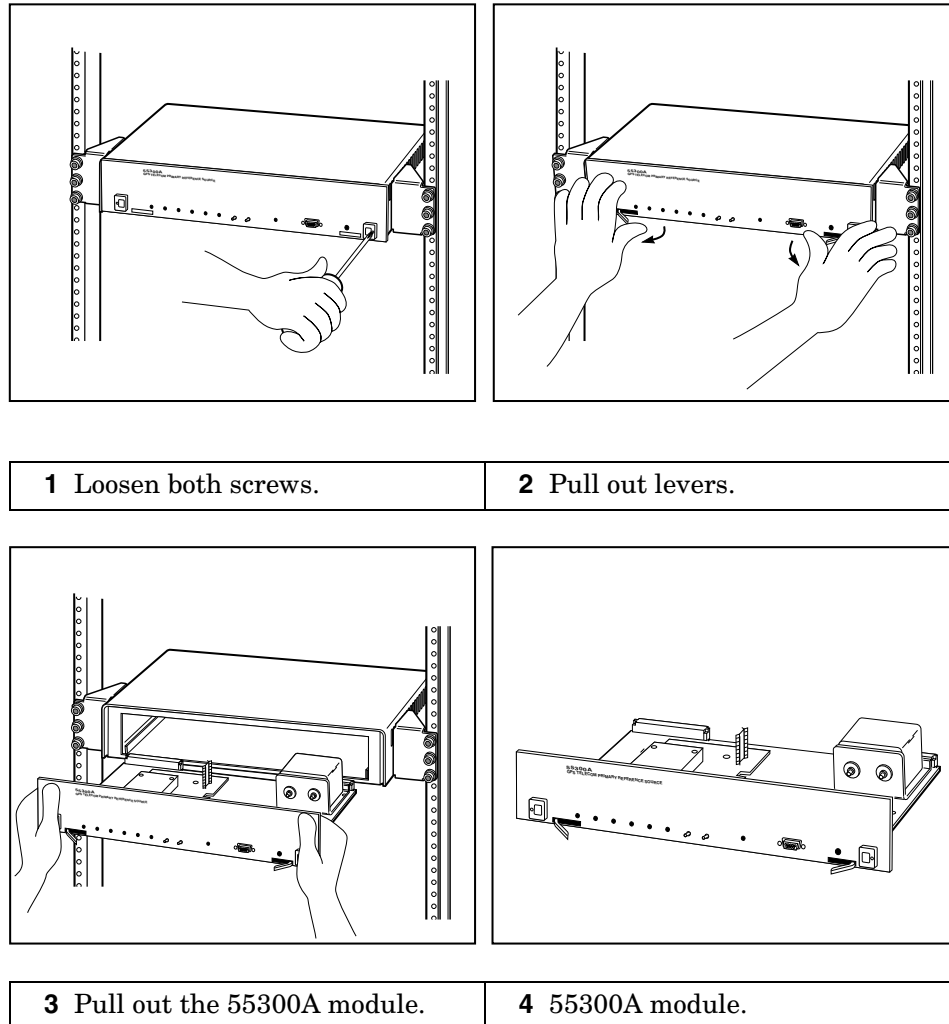

**Figure 6-7. 55300A Module Removal**

### To Remove A1 Main Board Assembly

- 1** From the bottom of the 55300A module, remove three short T-15 (H1) screws (0515-0433) and the two T-9 (H3) screws (E1400-00610) and their levers (MP1—E1400-45101, MP2—E1400-45102) as shown in Figure 6-8. (Note: some older instruments have short Pozidriv® screws, 0515-0898.)
- 2** Remove three long T-15 (H2) screws (0515-0383) that attach A2 DC-DC Power Supply Assembly to A1 Main Board Assembly as shown in Figure 6-8.

Replacing Assemblies

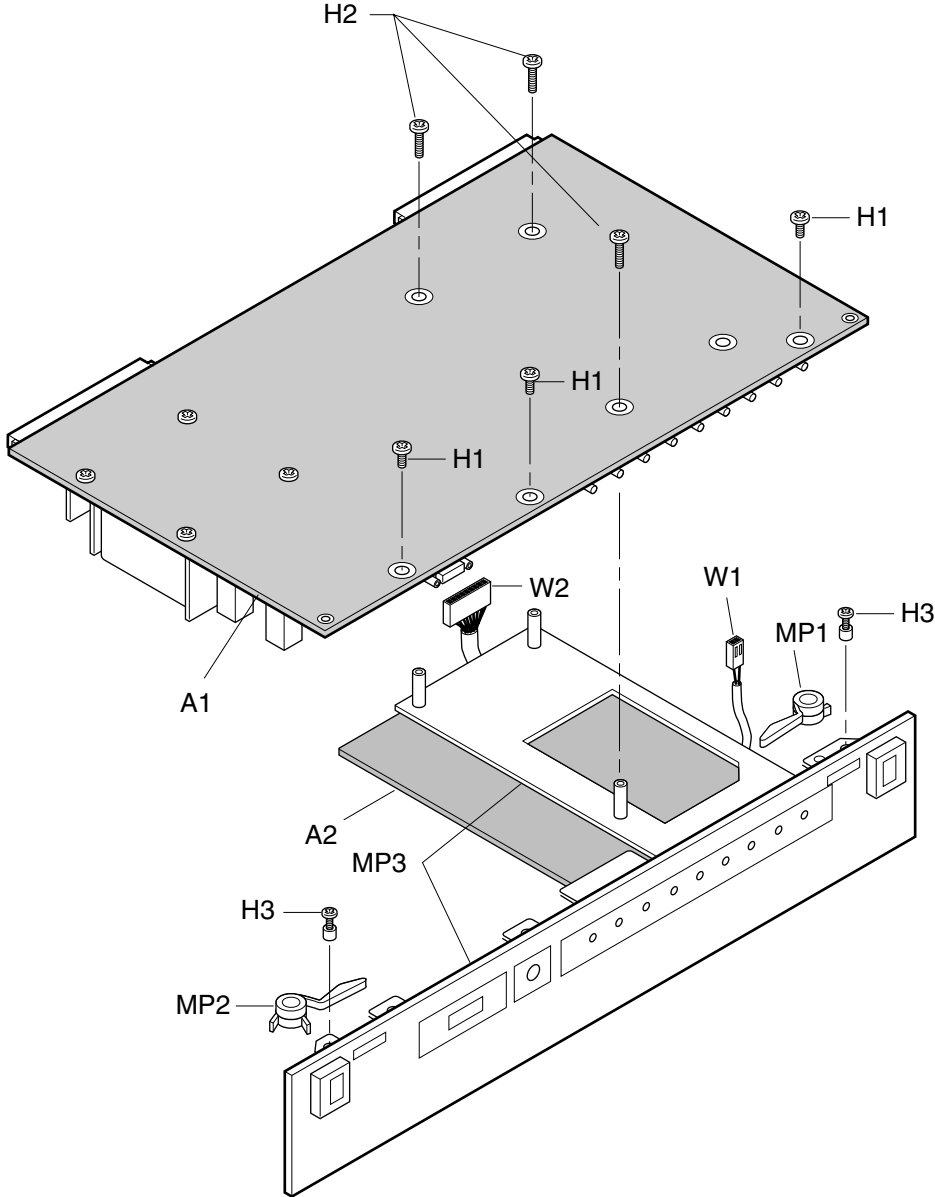

Figure 6-8. Front Panel and A1 Main Board Removal

## Replacing Assemblies

---

**CAUTION**

---

In the following step, Be CAREFUL not to break A1P2 and A1J1 connectors when disconnecting cables W1 and W2.

- 3 Using your hand, pull up on each connector end of cable W1 (the small cable, 55300-60202) to disconnect it from A2 DC-DC Power Supply Assembly as shown in Figure 6-8.
- 4 Using a medium flat-head screw driver, disconnect cable W2 (the large cable, 58503-60203) from A2 DC-DC Power Supply Assembly as shown in Figure 6-8.

Now, A1 Main Board Assembly is separated from the Front Panel/A2 DC-DC Power Supply assemblies.

---

**CAUTION**

---

Before installing your exchanged A1 Main Board Assembly, verify that the switches or jumper wires of S2 and S3 are set correctly for your 55300A option. Refer to the section titled “Switch or Jumper Wire Configuration Check” on page 6-17.

- 5 To install A1 Main Board Assembly, reverse this procedure.

### **To Remove A2 DC-DC Power Supply Assembly**

---

**CAUTION**

---

In the following step, Be CAREFUL not to break A1P2 and A1J1 connectors when disconnecting cables W1 and W2.

- 1 Disconnect or remove cable W1 by pulling up, using your hand, from the connector ends that connects the cable to A1 as shown in Figure 6-9.
- 2 Using a medium flat-blade screwdriver, gently pry loose cable W2 as shown in Figure 6-9.
- 3 From the top side of A2 DC-DC Power Supply Assembly, remove the four short T-15 (H1) screw (0515-0433) that attach A2 to the front panel (MP3) as shown in Figure 6-9. (Note: some older instruments have four Pozidriv screws, 0515-0898.)
- 4 Remove the T-10 (H4) screw (0515-0372) that chassis grounds A2, located near the front panel as shown in Figure 6-9. (Note: some older units may have a small Pozidriv screw, 0515-0886.)
- 5 To install A2 DC-DC Power Supply Assembly, reverse this procedure.



Chapter 6 Maintenance  
Replacing Assemblies

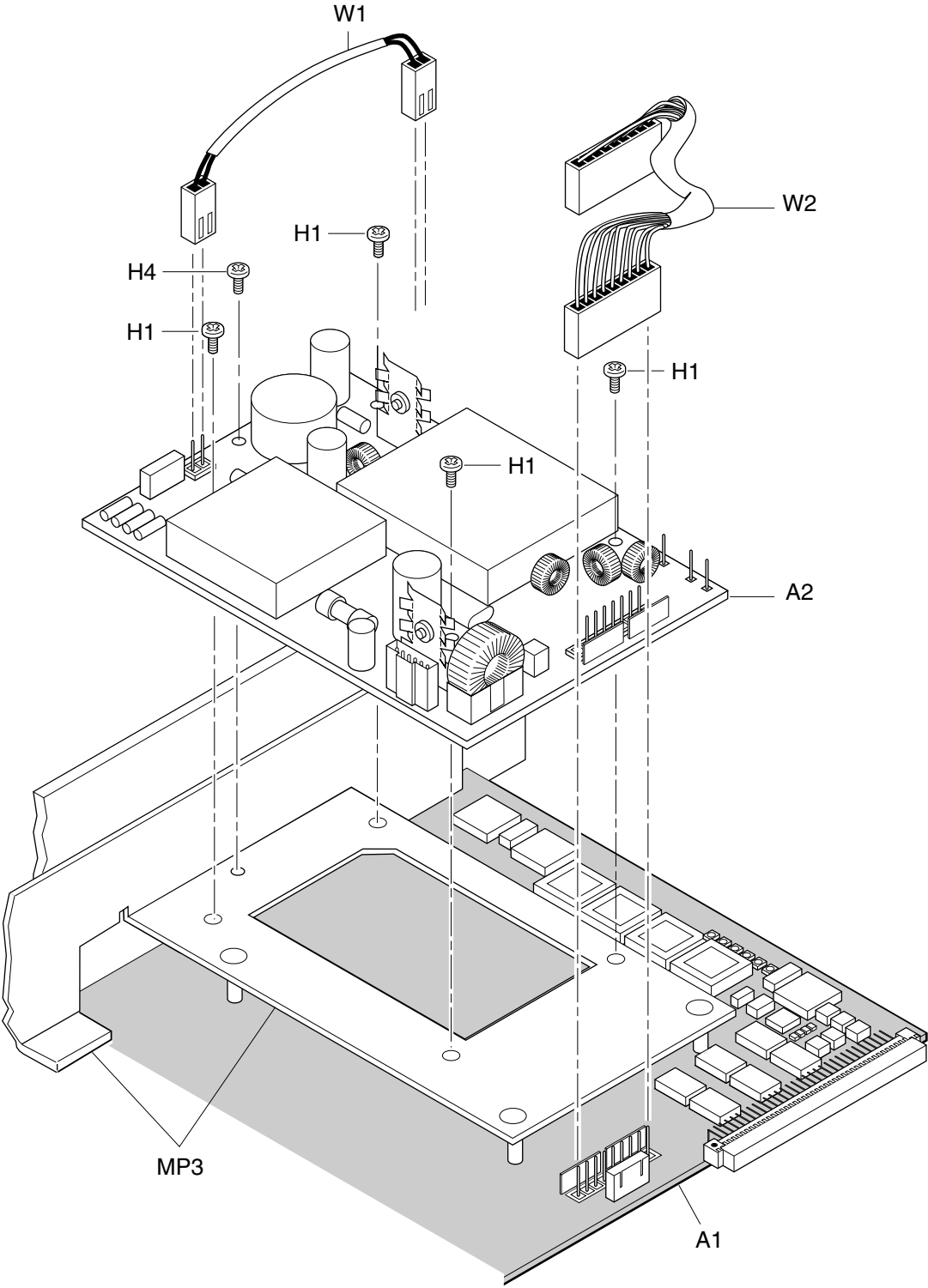

Figure 6-9. A2 DC-DC Power Supply Removal

---

## Testing Operation After Repairs

After replacement of any assembly in the 55300A module, perform the power-up selftest using the diagnostic LEDs located on A1 Main Board. This test is done before you re-install the module into its rack mount shelf.

After re-installing a properly operating module, perform the operational verification test in Chapter 2, “Acceptance Test,” of this guide.

### Overview of the Diagnostic LEDs

The 55300A Module contains six LEDs located on A1 Main Board as shown in Figure 6-10. These LEDs are for diagnostic purposes. One LED is green (1) and the other five are red (2 through 6).

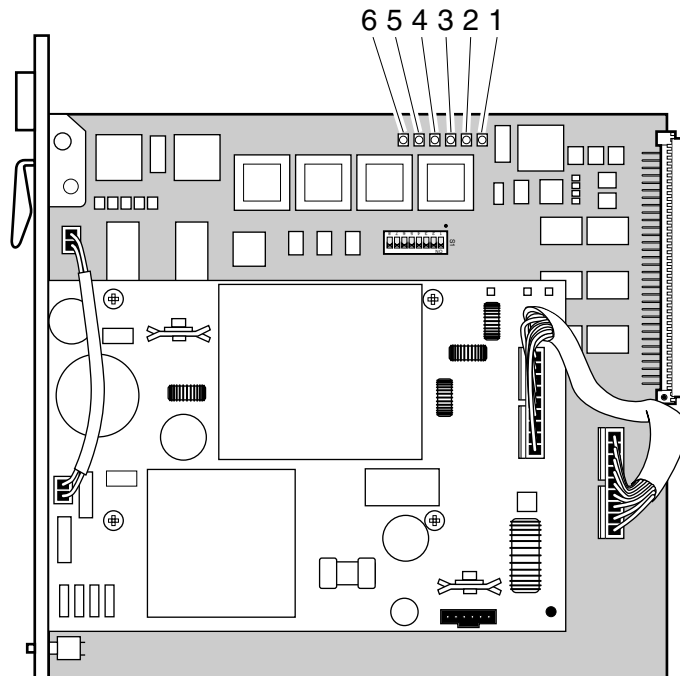

**Figure 6-10. A1 Main Board Diagnostic LEDs Location (Top View)**

## Testing Operation After Repairs

Table 6-7. A1 Main Board Diagnostic LEDs

Item in Figure 6-10	LED	ON	FLASHING	OFF	ON
1	Green	boot code	normal	broken	
2	Red 1	EPROM failure		normal	failure
3	Red 2	CPU failure		normal	failure
4	Red 3	RAM failure		normal	failure
5	Red 4	UART failure		normal	failure
6	Red 5	qspi, fpga, interpolator, GPS, power		normal	failure

**NOTE**

If the 10811 oscillator is not connected or is not working, then the FPGA and interpolator tests will fail. This will result in LED Red 5 being illuminated.

When the module is working properly, all of the LEDs should illuminate when power is applied, and then turn off. The green LED should then start flashing with a 1 second on, and 1 second off cycle.

If the green LED is off, the module software has probably crashed because of a hardware problem.

If the green LED is continually on, the module is probably in the boot code.

If all of the LEDs stay illuminated when power is applied, then one or more of the following is not functional: the reset circuit, the processor, or the EPROM's. Table 6-7 lists and describes the diagnostic LEDs on A1 Main Board.

## Testing Operation After Repairs

### To Perform the Power-Up Diagnostic Selftest

- 1 Turn on the HP 6633A (or equivalent) DC Power Supply.
- 2 Set the HP 6633A (or equivalent) DC Power Supply to output 48 Vdc and 2 amps of current.

---

**NOTE**

---

The power supply's output leads will be reversed at the connection to the 55300A in steps 5 and 6 to get a negative input voltage (-48 Vdc) output.

- 3 Using a DMM or voltmeter, verify that the voltmeter reads 48 Vdc  $\pm$ 5V.
- 4 Connect the negative lead of the HP 6633A (or equivalent) DC Power Supply (or equivalent) to pin C1 of the 96-pin connector that is near A2 DC-DC Power Supply Assembly as shown in Figure 6-3.
- 5 Connect the positive lead of the dc power supply to pin C32 of the 96-pin connector as shown in Figure 6-3, and note that the following occurs:

All of the LEDs should illuminate when power is initially applied, and then they should turn off. The green LED should then start flashing with a 1 second on, and 1 second off cycle.

- 6 If step 5 worked properly, the module is okay and ready for installation.

If step 5 failed, determine what the problem might be by reading over the information provided in the previous section titled "Overview of the Diagnostic LEDs."

---

## Replaceable Parts

This section contains information for ordering parts. Table 6-8 lists the exchange assemblies. Table 6-9 lists reference designations used in the parts list, and Table 6-10 lists replaceable assemblies and parts for the 55300A GPS Telecom Primary Reference Source.

### Exchange Assemblies

Table 6-8 lists the assembly within the 55300A that may be replaced on an exchange basis. A factory repaired and tested exchange assembly is available only on a trade-in basis. A defective assembly must be returned for credit.

**Table 6-8. Exchange Assemblies**

Assembly Name	Part No.	Exchange Part No.*
A1 Main Board (Options 104 and 105)		55300-69101
A1 Main Board (Options 220, 221, 270, 271, and 272)		55300-69102

\* Exchange part availability is subject to change without notice.

### Reference Designations

Table 6-9 lists the reference designations used in the parts lists, exploded views, and throughout this chapter.

### About the Replaceable Parts List

Table 6-10 is a list of replaceable parts and is organized as follows:

1. Electrical assemblies in alphanumerical order by reference designation.
2. Chassis-mounted electrical parts in alphanumerical order by reference designation.
3. Chassis-mounted mechanical parts in alphanumerical order by reference designation.

## **Replaceable Parts**

The information given for each part consists of the following:

1. Reference designation.
2. Part number.
3. Part number check digit (CD).
4. Total quantity (QTY) in instrument. The total quantity is given once and at the first appearance of the part number in the list.
5. Description of the part.
6. Typical manufacturer's part number for the part.

## **How To Order A Part**

To order parts perform the following steps:

- 1 Identify the part and the quantity you want.
- 2 Determine the ordering method to be used and contact Symmetricom.

## ***Parts Identification***

To identify the part(s) you want, first refer to figures 6-1, 6-8, and 6-9. These figures provide different views of the instrument, with the parts identified by reference designations; the reference designations correspond with the ones in Table 6-10.

When ordering, the important numbers to note from the Parts List are the Part Number and part-number check digit (in the “CD” column), and the quantity of the part you want.

If the part you want is NOT identified in the guide, you can call Symmetricom for help. Please have the following information at hand when you call for help:

- Instrument Model Number (example, “55300A”).
- Complete instrument Serial Number (example, “3626A00263”). The serial number can be found on the outside of the front panel (MP3) of the 55300A module. Some older instruments have the serial number located on the inside of the front panel of the 55300A module.
- Description of the part and its use.
- Quantity of the part required.

**Replaceable Parts****Chassis Parts and Hardware**

To locate and identify miscellaneous chassis parts and instrument hardware, refer to Figures 6-1, 6-8, and 6-9. These figures provide different views of the instrument, with the parts identified by reference designations; the reference designations correspond with the ones in Table 6-10.

**Table 6-9. Reference Designations**

A = assembly	E = miscellaneous electrical part	MP = miscellaneous mechanical part	TP = test point
AT = attenuator; isolator; termination	F = fuse	P = electrical connector (movable portion); plug	U = integrated circuit; microcircuit
B = battery	FL = filter	Q = transistor; SCR; triode thyristor	V = electron tube
C = capacitor	H = hardware	R = resistor	VR = voltage regulator; breakdown diode
CP = coupler	HY = circulator	RT = thermistor	W = cable; transmission path; wire
CR = diode; diode thyristor; varactor	J = electrical connector (stationary portion); jack	S = switch	X = socket
DC = directional coupler	K = relay	T = transformer	Y = crystal unit—piezo-electric
DL = delay line	L = coil; inductor	TB = terminal board	Z = tuned cavity; tuned circuit
DS = annunciator; signaling device (audible or visual) lamp; LED	M = metre	TC = thermocouple	

**Replaceable Parts List****Table 6-10. 55300A Replaceable Parts**

Reference Designation	Part Number	C D	Qty	Description	Mfr Code	Mfr Part Number
<b>EXCHANGE ELECTRONIC ASSEMBLIES</b>						
A1 (for Options 104, 105)	55300-69101	0	1	MAIN BOARD (EXCHANGED-RESTORED)	28480	55300-69101
A1 (for Options 220, 221, 222, 270, 271, 272)	55300-69102	1	1	MOTHERBOARD (EXCHANGED-RESTORED)	28480	55300-69102
<b>ELECTRONIC ASSEMBLIES</b>						
A2	58503-60003	4	1	DC-DC POWER SUPPLY	28480	58503-60003
<b>CHASSIS PARTS</b>						
H1	0515-0433	6	7	SCREW-MACH TORX 15 M4.0X.07: 8MM	00000	ORDER BY DESCRIPTION
H2	0515-0383	5	3	SCREW-MACH TORX 15 M4.0X.07: 16MM	00000	ORDER BY DESCRIPTION
H3	E1400-00610	6	2	SCREW-MACH TORX 9 AND SPACER	28480	E1400-00610
H4	0515-0372	2	1	SCREW-MACH TORX 10 M3.0 X 0.5: 8MM	00000	ORDER BY DESCRIPTION
MP1	E1400-45101	4	1	LEVER-LFT (VIEWING FROM FRONT OF UNIT)	28480	E1400-45101
MP2	E1400-45102	5	1	LEVER-RHT (VIEWING FROM FRONT OF UNIT)	28480	E1400-45102
W1	55300-60202	4	1	CABLE -48V POWER	28480	55300-60202
W2	58503-60203	5	1	CABLE-MAIN BOARD REG DC SUPPLY	28480	58503-60203

---

## Backdating

### ***CHANGE 1***

---

**NOTE**

Depending on when your 55310A/55320A Rack Mount Shelf was manufactured, the two supplied dc power plugs could be the four-pin, dc power connector plugs (HP Part Number 0360-2599) (or equivalent) or the three-pin, dc power connector plugs (HP Part Number 1251-5271) (or equivalent). Older versions of the 55300A/55310A/55320A were supplied with the four-pin dc power plugs (0360-2599) (or equivalent).

Replace pages 1-10 through 1-13 (the section titled “To Connect DC Power”) with the following text *if you are using the four-pin dc power plugs (0360-2599)*.

### **To Connect DC Power**

#### ***Power Requirements***

Due to the high reliability requirements for telecom equipment, it is recommended that you take advantage of the dual-redundant power supply capability of the 55300A by providing two separate power connections to the rack mount shelf from separate power sources.

#### ***Current Demands***

The 55300A maximum current usage is 1 Amp at –48 Vdc. From a cold start, the current is about 0.75 amps. After the cold start, the current usage drops to about 0.33 amps.

#### ***Connecting DC Power If No Power Cables Exist***

- 1 Note that you will have to assemble your own dc power cables using 20 AWG (0.08 inch or 2 mm diameter) connecting wires and the supplied, four-pin, dc power connector plugs (HP Part Number 0360-2599) (or equivalent) as shown in Figure 1-2A.

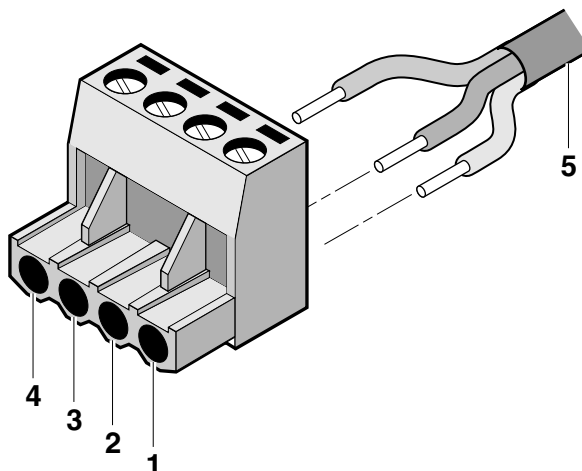

**Backdating****CHANGE 1 (Continued)**

- |                                       |                          |
|---------------------------------------|--------------------------|
| 1 -48 Vdc battery supply              | 4 Frame (chassis) ground |
| 2 dc (battery) return (common ground) | 5 Cable wires            |
| 3 dc (battery) return (common ground) |                          |

**Figure 6-11. Four-Pin DC Connector Pin Assignments**

- 2 Strip 0.350 inch (9 mm) of insulation from the wires. (Use wires no larger than 0.08 inch or 2 mm in diameter.)
- 3 From the rear of the plug, connect the supply-side wire of the external power supply or battery to pin 1 of the plug. Connect the external battery's return (ground) wire to either pin 2 or pin 3, and the chassis ground wire, if present, to pin 4 of the plug.

**CAUTION**

**SYSTEM GROUNDING.** Common ground on the rack mount shelf (55310A, 55320A, or 55322A) for each -48 Vdc supply is the battery return. The frame ground, or chassis ground, must be separate from the common ground.

A frame ground can be connected in one of three ways:

- As part of the -48 Vdc four-pin connector plug.
- Through a single-wire connection to the ground stud on the rear panel (55310A) or top front panel (55320A/55322A). (Use a spade lug.)

## Backdating

### *CHANGE 1 (Continued)*

- Through the rack mount brackets and the 55300A/55310A (or 55300A/55320A/55322A) when the rack itself is properly grounded.

---

**CAUTION**

---

To prevent battery return-to-frame ground faults, DO NOT connect battery return on the 55310A/55320A/55322A rack mount shelf to the frame ground.

- 4 Observing the correct polarity, attach the other ends of the wires to a proper dc power source to operate the 55300A.
- 5 Observing the correct polarity, insert the plug into the **POWER A –48 VDC INPUT** jack of the 55310A, 55320A, or 55322A rack mount shelf.
- 6 Repeat steps 1 through 4 for the rear-panel **POWER B –48 VDC INPUT** jack of the rack mount shelf for redundant or “alternate” dc power.

Refer to the subsection titled “POWER A and B –48 VDC Inputs” in Chapter 3, “Features and Functions,” in this guide for more information on the dc power inputs.

### *Connecting DC Power Using Existing Site Power Cables*

- 1 Using the multimeter, verify that there are no multiple battery grounds, or any shorts at the power source end of the wires.
- 2 From the rear of the plug (see Figure 1-2A), connect the supply-side wire of the external power supply or battery to pin 1 of the plug. Connect the external battery’s return (ground) wire to either pin 2 or pin 3, and the chassis ground wire, if present, to pin 4 of the plug.
- 3 Using a multimeter, verify a reading between –45 to –60 Vdc across pin 1 of the dc connector and the dc return pin (2 or 3).
- 4 Observing the correct polarity, insert the plug into the rear-panel **POWER A –48 VDC INPUT** jack of 55310A, 55320A, or 55322A rack mount shelf.
- 5 Repeat steps 1 through 4 for the rear-panel **POWER B –48 VDC INPUT** jack of the rack mount shelf for redundant or “alternate” dc power.

Refer to the subsection titled “POWER A and B –48 VDC Inputs” in Chapter 3, “Features and Functions,” in this guide for more information on the dc power inputs.

---

A

---

Performance Test Information

**Appendix Contents**

---

## Appendix Contents

This appendix provides a place to insert your factory-tested results of the MTIE, TDEV, and Holdover specifications. These specifications results are provided with your 55300A. A phase jitter graph is also provided.

---

# Index

## NUMERICS

- 1 PPS, 1-5, 1-7
- 1 PPS BNC outputs, 3-16
- 1 PPS connectors, 1-7
- 1 PPS DE-9S outputs, 3-17
- 1 PPS output, 3-14
- 1 PPS outputs, 3-16
  - negative and positive, 3-16
- 1 PPS wire-wrap connectors, 1-5
- 10 MHz, 1-5
- 10 MHz output, 1-7, 3-14
- 1544 kbps signal, 3-9
- 1544 kHz output, 3-8
- 2048 kbps output, 1-7
- 2048 kbps outputs, 3-11
- 2048 kbps signal, 3-9
- 2048 kHz output, 1-7, 3-8
- 2048 kHz outputs, 3-13
- 48 Vdc, 1-10, 3-7, 6-34

## A

- acceptance performance test
  - information, A-2
- acceptance test, 2-2, 2-8
- acceptance test record, 2-27, 2-28
- accessing Security Switch S1, 3-37
- accessories, xix
  - available, xix
  - supplied, xix
- ACO Active indicator, 3-19
- ACO pushbutton, 1-3
- ACO pushbutton control
  - ACO, 3-20
- ACO Reset pushbutton, 1-3
- ACO reset pushbutton control, 3-20
- acquiring GPS lock, 3-42
- ACQUISITION, 4-11, 4-14
- adapter, xx
- AIS, 3-43
- alarm condition, xvi, 3-20
- alarm cutoff, 3-20
- alarm defaults, 3-22
- Alarm Indication Signal (AIS), 3-43
- alarm indicator, 3-19
- alarm, remote, 3-22
- alarms, 3-22
- ALARMS connector, 1-7, 3-22
- antenna, 3-4
  - assembling, 1-10
  - cable length delay, 3-5
  - delay values, 3-5
  - installation, 1-10
  - propagation delay, 3-5

- antenna assembly, xix
- antenna cable, xx, 3-4
- antenna cables, xx
- ANTENNA connection, 1-5, 1-7
- antenna delay, 4-16
- Antenna Line Amplifier, xx
- application note, xi, xxi
- arrester
  - lightning, xix
- assemblies, exchange, 6-31
- assembling power, 1-13, 6-36
- assembly
  - A1 Main Board, 6-5
  - A2 DC-DC Power Supply, 6-5
    - removal, 6-23
    - replacement, 6-23
- assembly identification, 6-6
- assembly identification and location, 6-5
- assembly removal, 6-23
- assembly replacement, 6-23
- azimuth angle, 4-15

## B

- backdating, 6-34
- balanced outputs, 3-8
- banana jack, 1-3, 1-5, 1-7
- baud rate, 3-33
- Belden® 8267 cable, 3-4

## C

- cabinet parts and hardware, 6-33
- cable
  - antenna, xx, 3-4
  - interconnect, antenna, xx
  - interface, xx
  - interface, laptop, xx
  - interface, Omni Book, xx
  - LMR 400, 3-4
  - recommended, 3-4
  - RG-213, 1-10, 3-4
  - W1 -48 Vdc, 6-5
  - W2 regulated dc supply, 6-5
- cable assemblies, 3-4
- cable length delay, 3-5
- cables, 3-6
  - making your own RS-232C cables, 3-32
- CAS, 3-8
- CCS, 3-8
- CCS-CRC4, 3-8
- Central Office, 3-24
- changes
  - manual, 6-34
- changing RS-232C port settings, 3-34

## Index

- changing the password, 3-40
  - Channel Associated Signaling, 3-8
  - characteristics, 5-2
  - chassis ground, 1-5, 1-7, 3-10
  - commands, 1-28
  - commands, SCPI, 1-28
  - Common Channel Signaling, 3-8
  - communications, xv
    - REMOTE ACCESS PORT, 1-14
    - SCPI, 1-14
    - TIME OF DAY, 1-14
    - TL1, 1-14
  - compensate for antenna cable delay, 1-29
  - concepts
    - operating, 3-42
  - configuration
    - jumpers, 6-17
    - switches, 6-17
  - configuration guide, xi, xxi, 1-10
  - configure terminal communications, 1-17, 1-18, 1-19
  - configuring PORT 1, 3-35
  - configuring REMOTE ACCESS PORT, 3-35
  - configuring the RS-232C port(s), 3-33
  - configuring TIME OF DAY, 3-35
  - connecting
    - HP 55300A to a Laptop, 3-28
    - HP 55300A to a modem, 3-28
    - HP 55300A to a palmtop, 3-31
    - HP 55300A to a PC, 3-28, 3-30
    - HP 55300A to a Terminal, 3-29
    - Receiver to Laptop, 3-3
    - Receiver to PC, 3-3
  - connecting a computer or modem, 3-27
  - connecting dc power, 1-11, 6-34
  - connecting to computer, 1-14
  - connectivity cable, xx
  - connector
    - ALARMS, 1-7
  - connectors
    - ALARMS, 3-22
    - pin assignments
      - 1 PPS DE-9S, 3-17
    - Remote wire-wrap, 3-21
    - Remote wire-wrap connectors, 1-5
  - continuous, 3-13
  - continuous mode
    - description, 3-43
  - continuous signal, 3-10
  - control
    - ACO, 3-20
    - ACO Reset, 3-20
  - control and communications, xv
  - controls, 3-20
  - Coordinated Universal Time (UTC), 3-14
  - Critical Alarm indicator, 3-19
  - current demands, 1-10, 6-34
  - current usage, 1-10, 6-34
  - customizing installation, 1-28
  - customizing the Receiver operation, 1-27
  - Cyclic Redundancy Check, 3-8
- ## D
- data bits, 3-33
  - Data Terminal Equipment, 3-27
  - DB-25 to DB-9 serial connection, 3-33
  - DB-9 to DB-9 serial connection, 3-32
  - dc jack, 6-36
  - dc plugs, 1-11, 6-34
  - dc power, 3-7
  - dc power requirements, 1-10, 6-34
  - DCE device, 3-27
  - default values, 1-17, 1-19
  - defaults
    - alarm, 3-22
  - defective assemblies, 6-31
  - delay value, 3-6
  - delay values, 3-5
  - description
    - continuous mode, 3-43
    - holdover, 3-42
    - holdover action, 3-43
    - HP 55300A, xiv, xv
    - physical, xv
    - product, xv
    - squelched mode, 3-43
  - diagnostic LEDs, 6-28
  - Diagnostic Log, 6-7, 6-9
  - diagnostic selftest
    - power-up, 6-30
  - difficulty
    - in case of a problem, 3-45
  - Digital Communication Equipment, 3-27
  - disabling the security feature, 3-41
  - disassembling, 6-23
  - disassembly
    - A1 main board, 6-24
    - A2 power supply, 6-26
    - main board, 6-24
    - power supply, 6-26
  - displaying the status screen, 1-22, 1-23
  - documentation map, xi
  - documents
    - available, xxi
  - DS1, 3-8
    - wire-wrap connector, 3-9
  - DS1 D4, 3-8
  - DS1 ESF, 3-8
  - DS1 signal, 3-9
  - DS1 wire-wrap connectors, 1-5
  - DTE device, 3-27

dual redundant power, 3-7

## **E**

### **E1**

- non-US, 3-9
- switch setting, 6-21

ED-PID password command, 3-40

EFC, 4-18

electrostatic discharge, 6-4

Electrostatic Discharge strap, 3-7

Electrostatic Discharge strap  
connection, 3-7

elevation angle, 4-15

elevation mask angle, 1-30, 4-15

enabling the security feature, 3-39

equipment

- required, 2-3
- test, 2-3

ESD connection, 3-7

ETSI (International) version (balanced  
outputs), xviii

ETSI (International) version (unbalanced  
outputs), xix

example commands, 1-28

exchange

- assemblies, 6-31

exchange assemblies, 6-5

Extended Super Frame, 3-8

## **F**

factory-default configuration

- jumpers, 6-17
- switches, 6-17

factory-default values, 3-33

factory-tested results, A-2

features and functions, 3-2

FFOM (Frequency Figure of Merit), 3-42

FFOM value, 4-13

formatted outputs, 3-11

front panel

- HP 55300A, 1-2
- HP 55300A Module, xvi

front panel at a glance, 1-2

Full Duplex, 3-34

functions, 3-2

## **G**

G.703

- recommendation standard, 3-9

GPS ANTENNA input, 3-4

GPS Lock indicator, 3-18

GPS Lock LED, 1-3

GPS time, 4-16

ground plane, xix

ground stud, 1-5, 1-7

guide organization, xiii

## **H**

HEALTH MONITOR, 4-11, 6-7, 6-8

health monitor screen, 4-11

height, 1-31

help from HP, 2-2, 2-8, 3-5

Hold position mode, 4-17

Holdover, 4-12

holdover, 3-18

holdover action for telecom outputs, 3-43

holdover description, 3-42

holdover duration threshold2, 3-44

Holdover indicator, 3-18

Holdover LED, 1-3

holdover mode, 6-9

holdover operation, 4-7

holdover threshold, 4-14

HP 24542G Interface Cable, xx, 3-28,  
3-33

HP 24542U Interface Cable, xx

HP 40242M Interface Cable, xx, 3-28

HP 55300A, 1-2

HP 55300A assembly identification, 6-5

HP 55300A Module, xvi

HP 55310A, 1-4

HP 55310A Rack Mount Shelf, xvi

HP 55320A/55322A Rack Mount  
Shelf, xvii

HP 58506A 50ft Cable, xx

HP 58509A antenna line amplifier, xx

HP 58510A GPS, xix

HP 58518A/519A cable, 3-6

HP 58518AA/519AA cable, 3-6

HP 58520A/521A cable, 3-6

HP F1021B Palmtop Connectivity  
Pack, xx

HP F1047-80002 cable, 3-32

HP SatStat, 4-3

operating, 1-26

HP SmartClock, 3-18, 4-9, 4-11

HP Telecom Mask Test Disk, xix

HP Telecom Mask Test disk, 2-3

## **I**

identifying assemblies, 6-5

Ignore, 4-15

in case of a problem, 3-45

indicator

ACO Active, 1-3, 3-19

Critical, 1-3

Critical Alarm, 3-19

GPS Lock, 1-3, 3-18

Holdover, 1-3, 3-18

Major, 1-3

Major Alarm, 3-19

Minor, 1-3

Minor Alarm, 3-19

## Index

- Power, 1-3, 3-18
- indicators, 3-18
- input
  - antenna, 3-4
  - antenna, GPS, 1-5, 1-7
  - GPS ANTENNA, 1-5, 1-7
  - POWER A, 1-5, 1-7
  - POWER B, 1-5, 1-7
- Input/Output (I/O), 3-24
- inputs, 3-4
- installation
  - antenna, 1-10
  - HP 55300A, 1-9
  - rack mount shelf, 1-9
- installing
  - A1 main board, 6-26
  - A2 power supply assembly, 6-26
  - main board, 6-26
  - power supply assembly, 6-26
- instrument
  - cabinet parts and hardware, 6-33
  - defective assemblies, 6-31
  - parts identification, 6-32
  - pre-troubleshooting information, 6-3
  - recommended test equipment, 6-3
  - replaceable parts, 6-31
  - serial and model number, 6-32
- insulation
  - stripping wire, 6-35
- interconnect cables, xx
- interface cable, xx
  - palmtop, xx
- interface cables, xx, 3-27
- interface port
  - PORT 1, 3-24, 3-25
  - REMOTE ACCESS PORT, 1-5, 1-7, 3-24
  - TIME OF DAY, 1-5, 3-26
- IRIG-B, 1-5, 1-7
- IRIG-B output, 3-14
- J**
  - jack, 6-36
    - banana, ESD, 1-3, 1-5, 1-7
    - ESD strap, 3-7
  - jumpers, 6-17
- K**
  - keypad entry, xv
- L**
  - laptop interface cable, xx
  - latitude, 1-31
  - LED
    - ACO Active, 1-3, 3-19
    - Critical, 1-3
    - Critical Alarm, 3-19
    - GPS Lock, 1-3, 3-18
    - Holdover, 3-18
    - Major, 1-3
    - Major Alarm, 3-19
    - Minor, 1-3
    - Minor Alarm, 3-19
    - Power, 1-3, 3-18
  - LEDs
    - A1 main board, 6-28
  - Light-Emitting-Diode, xvi
  - lightning arrester, xix
  - line amplifier, xx
  - line amplifier requirements, 3-5
  - list of equipment, 2-3
  - list, replaceable parts, 6-33
  - LMR 400 cable, 3-4
  - LMR cables, 1-10
  - Local (with ACO) wire-wrap
    - connectors, 1-5, 3-20
  - local time, 1-30
  - local time zone, 4-16
  - locating, S1, 3-37
  - log, diagnostic, 6-9
  - longitude, 1-31
- M**
  - main board check, 6-12
  - maintenance, 6-2
  - Major Alarm indicator, 3-19
  - making RS-232C cables, 3-32
  - manual changes, 6-34
  - manual maps, xi
  - manual organization, xiii
  - manuals, xxi
  - map
    - documentation, xi
    - manuals, xi
  - matching serial port settings, 3-36
  - maximum current, 1-10, 6-34
  - Minor Alarm indicator, 3-19
  - model number, 6-32
  - MONITOR
    - output, 3-9
  - MONITOR output jack, 1-3
- N**
  - NC (normally-closed contact) relay
    - contact, 3-21
  - NEBS (US) version, xviii
  - NO (normally-opened contact) relay
    - contact, 3-21
  - not tracking, 4-14
  - Not Tracking column, 4-9
- O**
  - Omni Book interface cable, xx
  - One Pulse Per Second, 3-14



## Index

- operating concepts, 3-42
  - operational verification, 2-4
  - operational verification test, 2-2
  - Option 104, xviii, 3-9
  - Option 105, xviii, 3-9
  - Option 200s, 3-11
  - Option 220, xviii
  - Option 221, xviii
  - Option 222, xviii
  - Option 270, xix
  - Option 271, xix
  - Option 272, xix
  - options, xviii
    - ETSI (International) version (balanced outputs), xviii
    - ETSI (International) version (unbalanced outputs), xix
    - NEBS (US) version, xviii
  - ordering parts, 6-32
  - organization
    - guide, xiii
    - manual, xiii
  - output
    - 1 PPS, 1-5, 1-7, 3-14
    - 10 MHz, 1-5, 1-7, 3-14
    - 2048 kbps, 1-7
    - 2048 kHz, 1-7
    - A and B, 1-5
    - IRIG-B, 1-5, 1-7
    - MONITOR, 1-3, 3-9
  - Output A and B, 1-5, 3-10
  - outputs
    - 1 PPS, 3-16
    - 1 PPS BNC, 3-16
    - 1 PPS DE-9S, 3-17
    - 1544 kHz, 3-8
    - 2048 kbps, 3-11
    - 2048 kHz, 3-8, 3-13
    - A and B, 3-10
    - formatted, 3-11
    - IRIG-B, 3-14
    - negative and positive 1 PPS, 3-16
    - options, 3-8
    - telecom options, 3-8
    - telecom output, 3-8
    - telecommunication options, 3-8
    - telecommunications output, 3-8
    - time and frequency, 3-14
    - wire-wrap connector 1 PPS, 3-16
- P**
- pace, 3-33
  - pacing, 3-33
  - palmtop cable, xx
  - parameters, 3-33
  - parity, 3-33
- part numbers, 6-31
  - parts identification, 6-32
  - parts, ordering, 6-32
  - password, 1-22, 3-39, 3-40
  - password command, ED-PID, 3-40
  - password, changing, 3-40
  - performance test information, A-2
  - performance tests, 2-2
  - physical description, xv
  - pin assignment
    - REMOTE ACCESS PORT, 3-25
  - pin assignments
    - 1 PPS DE-9S connectors, 3-17
    - 2048 kbps output, 3-12
    - ALARMS connector, 3-23
    - dc connector, 1-11, 6-35
    - PORT 1, 3-26
    - TIME OF DAY, 3-27
  - plugs, 1-11, 6-34
  - PORT 1, 1-3, 3-24, 3-25
    - configuring, 3-33
  - Position, 4-17
  - position survey, 1-29
  - power, 3-7
  - POWER A input, 1-5, 1-7
  - POWER B input, 1-5, 1-7
  - power connection, 1-13, 6-36
  - Power indicator, 3-18
  - Power LED, 1-3
  - power requirements, 1-10, 6-34
  - power supply check, 6-12
  - power supply removal, 6-27
  - power supply voltages, 6-15
  - powering up the HP 55300A, 1-20
  - power-up procedure, 1-20
  - preparing for use, 1-9
  - preset all serial port's factory-default values, 3-37
  - Pre-troubleshooting information, 6-3
  - programming guide, xi, xxi
  - pseudorandom noise, 4-15
  - published specifications, 2-2
  - pushbutton control
    - ACO, 3-20
  - pushbutton switch
    - ACO, 1-3
    - ACO Reset, 1-3
- Q**
- quality
    - FFOM, 4-13
    - signal, 4-13
    - TFOM, 4-13
- R**
- R (ring), 3-10
  - rack mount shelf, 6-23

## Index

- ETSI, 1-8
- NEBS, 1-8
- rear panel
  - HP 55310A, 1-4
  - HP 55310A Rack Mount Shelf, xvi
- reassembling, 6-23
- reassembly
  - A1 main board, 6-26
  - A2 power supply, 6-26
  - main board, 6-26
  - power supply, 6-26
- Receiver Status Screen, 1-24, 4-3
- recommended test equipment, 2-3, 6-3
- Recovery, 4-12
- reference designations, 6-31
- relay circuit, 3-21
- REMOTE ACCESS PORT, 1-5, 1-7, 3-24
  - configuring, 3-33
- remote alarm, 3-22
- Remote wire-wrap connectors, 1-5, 3-21
- removal
  - A1 main board, 6-24
  - A2 power supply assembly, 6-26
  - HP 55300A module, 6-23
  - main board, 6-24
  - module, 6-23
  - power supply, 6-27
  - power supply assembly, 6-26
- repairs, after
  - internal self test, 6-28
  - operational verification test, 6-28
- replaceable assemblies, 6-31
- replaceable parts, 6-31
- replaceable parts list, 6-33
- replacing assemblies, 6-23
- REPT-ALARM, 3-19
- reset all serial port's factory-default values, 3-37
- restore all serial port's factory-default values, 3-37
- retrieving GPS status, 1-22
- retrieving the status screen, 1-22, 1-23
- RG-213 cable, 3-4
- RG-213 cables, 1-10
- RS-232 cables supplied, 1-10
- RS-232 default values, 1-17, 1-19
- RS-232 serial port(s), 3-24
- RS-232C, 1-5, 1-7
- RS-232C parameters, 3-33
- RS-232C serial interface ports
  - configuring, 3-33
- RS-422 signals, 3-17
- RTRV-ALRM, 3-19
- RTRV-PM-EQPT, 1-22, 1-23
- S**
- S (sleeve), 3-10
- S1, 3-37
  - Password Required position, 3-39
- S1, accessing, 3-37
- S1, locating, 3-37
- S2
  - switch, 6-17
- S3
  - switch, 6-17
- safety considerations, 6-3
- sample status screen, 1-25
- Satellite Status, 4-14
- SCPI, 1-5
- SCPI commands, 1-28
  - using, 1-21, 1-22, 1-23
- screen
  - status, 1-24
- screwdriver, 6-23
- security
  - setting up, 3-39
- security levels, 3-39
- Security Switch (S1), 3-37
- Security Switch (S1), accessing, 3-37
- Self Test, 4-18
- self test, 1-21, 2-5
- self-test diagnostics, 1-21, 2-5
- serial communication settings, 3-36
- serial interface, 1-3
- serial interface cables, 3-27
- serial interface port
  - PORT 1, 3-24, 3-25
  - REMOTE ACCESS PORT, 1-5, 1-7, 3-24
  - TIME OF DAY, 1-5, 1-7, 3-26
- serial number, 6-32
- serial port configuration, 3-36
- serial-port communication settings, 3-37
- service, 6-2
- settings
  - switches, 6-17
- shelf
  - ETSI, 1-8
  - NEBS, 1-8
- signal
  - quality, 4-13
- signal strength, 4-15
- SmartClock, 3-18
- SmartClock Mode, 4-12, 6-9
- SmartClock's PLL, 4-14
- Software pacing, 3-33
- specifications, 5-2
  - published, 2-2
- squelched, 3-13
- squelched mode
  - description, 3-43
- squelched signal, 3-10

## Index

- standard
  - G.703
    - recommendation, 3-9
- Status Screen, 1-24
- status screen, 1-25
- stop bits, 3-33
- strap
  - ESD jack, 3-7
- strength of the signal, 4-15
- Super Frame, 3-8
- Survey position mode, 4-17
- survey using command, 1-29
- surveying, 1-29
- switch setting, 6-17, 6-19, 6-20, 6-21
- switches, 6-17
- SYNCHRONIZATION, 4-11
- SYSTEM:
  - PRESET command, 1-28
  - STATUS?, 1-23
  - STATUS? command, 1-23
- T**
- T (tip), 3-10
- T1
  - switch setting, 6-19, 6-20
- table
  - regulated voltages, 6-15
- telecom output, 3-8
- telecommunications output, 3-8
- terminal emulation program*, 1-17
- test
  - acceptance, 2-2
  - operational verification, 2-2
- test equipment, 2-3, 6-3
- test record, 2-2, 2-27, 2-28
- TFOM value, 4-13
- threshold2
  - holdover duration, 3-44
- time and frequency outputs, 3-14
- time of day, 2-7
- TIME OF DAY PORT, 1-5, 1-7, 3-26
  - configuring, 3-33
- time zone, 1-30
- time, local, 1-30
- Timing Receiver Windows User
  - Interface, 1-25
- timing shift, 4-14
- TL1, 1-5, 1-7
- TL1 (Transaction Language 1), 3-24
- TL1 command, 3-11
- TL1 commands
  - using, 1-21, 1-22
- tolerance
  - voltages, 6-15
- tools
  - required, 6-23
- top front panel
  - HP 55320A/55322A Rack Mount Shelf, xvii
- top internal view, 6-6
- TORX® driver, 6-23
- troubleshooting
  - product performance checks, 6-4
- Tracking column, 4-9
- troubleshooting, 3-45, 6-2, 6-7
  - A1, 6-12
  - A2, 6-12
  - assembly identification and location, 6-5
  - cable W1, 6-16
  - disassembly and reassembly, 6-4
  - electrostatic discharge, 6-4
  - GPS accessories, 6-10, 6-11
  - GPS Antenna, 6-10
  - strategy, 6-7
- tutorial, 4-3
- U**
- unbalanced outputs, 3-8
- UTC, 3-14
- UTC (USNO), 3-14
- UTC time, 1-30, 4-16
- V**
- verification
  - operational, 2-2
- W**
- Windows, 1-23
- Windows application
  - Receiver Status screen, 1-25
- wire-wrap connector
  - DS1, 3-9
- wire-wrap connectors
  - 1 PPS, 1-5, 3-16
  - DS1, 1-5
  - Local (with ACO), 1-5, 3-20
  - Remote, 1-5
- Z**
- zone, time, 1-30

