

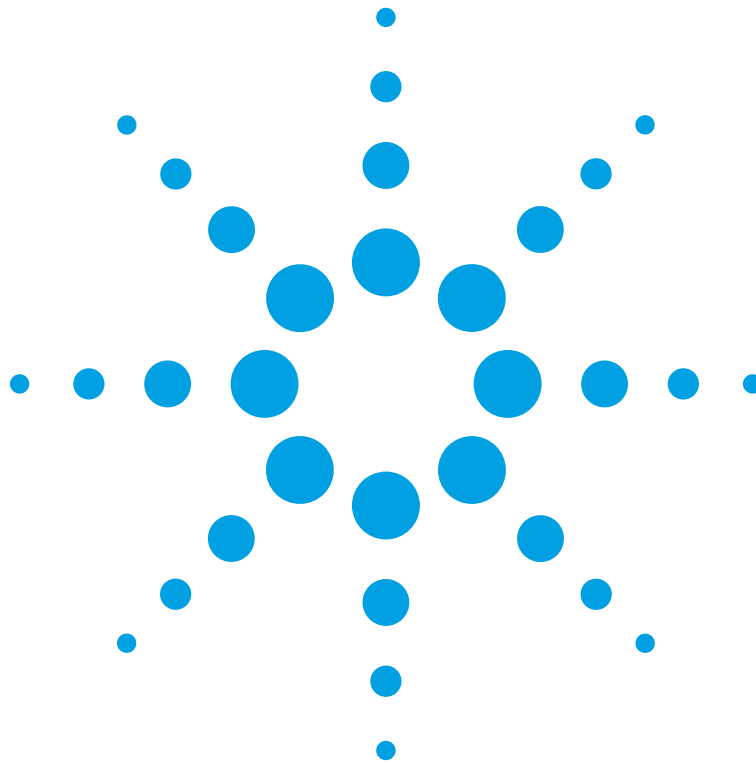

Advanced Test Equipment Rentals
www.atecorp.com 800-404-ATEC (2832)

Agilent 8163A/B Lightwave Multimeter,
Agilent 8164A/B Lightwave Measurement System, &
Agilent 8166A/B Lightwave Multichannel System

Programming Guide



Agilent Technologies

Notices

© Agilent Technologies, Inc. 2002-2005
This document contains proprietary information that is protected by copyright. All rights are reserved.

No part of this document may reproduced in (including electronic storage and retrieval or translation into a foreign language) without prior agreement and written consent from Agilent Technologies GmbH as governed by United States and international copyright laws.

Agilent Technologies Deutschland GmbH
Herrenberger Str. 130
71034 Böblingen
Germany

Manual Part Number

08164-90B64

Edition

Fifth edition, January 2005
Fourth edition, April 2003
Third edition, February 2002
Second edition, Oktober 2001
First edition, July 2001

Warranty

This Agilent Technologies instrument product is warranted against defects in material and workmanship for a period of one year from date of shipment. During the warranty period, Agilent will, at its option, either repair or replace products that prove to be defective.

For warranty service or repair, this product must be returned to a service facility designated by Agilent. Buyer shall prepay shipping charges to Agilent and Agilent shall pay shipping charges to return the product to Buyer. However, Buyer shall pay all shipping charges, duties, and taxes for products returned to Agilent from another country.

Agilent warrants that its software and firmware designated by Agilent for use with an instrument will execute its programming instructions when properly installed on that instrument. Agilent does not warrant that the operation of the instrument, software, or firmware will be uninterrupted or error free.

Limitation of Warranty

The foregoing warranty shall not apply to defects resulting from improper or inadequate maintenance by Buyer, Buyer-supplied software or interfacing, unauthorized modification or misuse, operation outside of the environmental specifications for the product, or improper site preparation or maintenance.

No other warranty is expressed or implied. Agilent Technologies specifically disclaims the implied warranties of Merchantability and Fitness for a Particular Purpose.

Exclusive Remedies

The remedies provided herein are Buyer's sole and exclusive remedies. Agilent Technologies shall not be liable for any direct, indirect, special, incidental, or consequential damages whether based on contract, tort, or any other legal theory.

Assistance

Product maintenance agreements and other customer assistance agreements are available for Agilent Technologies products. For any assistance contact your nearest Agilent Technologies Sales and Service Office.

Certification

Agilent Technologies Inc. certifies that this product met its published specifications at the time of shipment from the factory. Agilent Technologies further certifies

that its calibration measurements are traceable to the United States National Institute of Standards and Technology, NIST (formerly the United States National Bureau of Standards, NBS) to the extent allowed by the Institutes' calibration facility, and to the calibration facilities of other International Standards Organization members.

ISO 9001 Certification

Produced to ISO 9001 international quality system standard as part of our objective of continually increasing customer satisfaction through improved process control.

Safety Notices

CAUTION

A CAUTION notice denotes a hazard. It calls attention to an operating procedure, practice, or the like that, if not correctly performed or adhered to, could result in damage to the product or loss of important data. Do not proceed beyond a CAUTION notice until the indicated conditions are fully understood and met.

WARNING

A WARNING notice denotes a hazard. It calls attention to an operating procedure, practice, or the like that, if not correctly performed or adhered to, could result in personal injury or death. Do not proceed beyond a WARNING notice until the indicated conditions are fully understood and met.

Warnings and Notices

WARNING

To avoid the possibility of injury or death, you must observe the following precautions before switching on the instrument. Insert the power cable plug only into a socket outlet provided with a protective earth contact. Do not negate this protective action by the using an extension cord without a protective conductor.

WARNING

Never look directly into the end of a fiber or a connector, unless you are absolutely certain that there is no signal in the fiber.

Agilent Technologies Sales and Service Offices

For more information about Agilent Technologies test and measurement products, applications, services, and for a current sales office listing, visit our web site:

<http://www.agilent.com/comms/lightwave>

You can also contact one of the following centers and ask for a test and measurement sales representative.

United States:	1 800 829 4444 1 800 829 4433(FAX)
Canada:	1 877 894 4414 (1888 900 8921(FAX))
Europe:	(31 20) 547 2111 (31 20) 547 2190 (FAX)
Japan:	0120 421 345 0120 421 678 (FAX)
Mexico	(52 55) 5081 9469 (52 55) 5081 9467 (FAX)
Australia:	1 800 629 485 1 800 142 134 (FAX)
Asia-Pacific:	800 930 871 800 908 476 (FAX)
Brazil	(55 11) 4197 3600 (55 11) 4197 3800 (FAX)

In this Manual

This manual contains information about SCPI commands which can be used to program the following instruments:

- Agilent 8163A/B Lightwave Multimeter
- Agilent 8164A/B Lightwave Measurement System
- Agilent 8166A/B Lightwave Multichannel System

The Structure of this Manual

This manual is divided into 5 parts:

- *“Introduction to Programming” on page 15* gives a general introduction to SCPI programming with the Agilent 8163A/B Lightwave Multimeter, the Agilent 8164A/B Lightwave Measurement System, and the Agilent 8166A/B Lightwave Multichannel System.
- *“Specific Commands” on page 43* lists all instrument specific commands.
- *“Instrument Setup and Status” on page 55, “Measurement Operations & Settings” on page 79, and “Mass Storage, Display, and Print Functions” on page 185* give fuller explanations of all instrument specific commands.
- *“VISA Programming Examples” on page 189* gives some example programs showing how the SCPI commands can be used with the Agilent 8163A/B Lightwave Multimeter, the Agilent 8164A/B Lightwave Measurement System, and the Agilent 8166A/B Lightwave Multichannel System.
- *“The Agilent 816x VXIplug&play Instrument Driver” on page 213, “GPIB Command Compatibility List” on page 245, and “Error Codes” on page 257* give information about the Agilent 816x VXIplug&play Instrument Driver, compatibility issues, and error codes.

Conventions used in this Manual

- All commands and typed text is written in Courier font, for example INIT[:IMM].

- SCPI commands are written in mixed case: text that you **MUST** print is written in capitals; text which is helpful but not necessary is written in lower case.

So, the command INITiate[:IMMEDIATE] can be entered either as init[:imm], or as initiate[:immediate]. It does not matter whether you enter text using capitals or lower-case letters.

- SCPI commands often contain extra arguments in square brackets. These arguments may be helpful, but they need not be entered.

So, the command INITiate[:IMMEDIATE] can be entered as init or initiate:imm.

- A SCPI command which can be either a command or a query is appended with the text /?.

So, DISPlay:ENABLE/? refers to both the command DISPlay:ENABLE and the query DISPlay:ENABLE?.

Related Manuals

You can find more information about the instruments covered by this manual in the following manuals:

- *Agilent 8163A/B Lightwave Multimeter, Agilent 8164A/B Lightwave Measurement System, & Agilent 8166A/B Lightwave Multichannel System User's Guide* (Agilent Product Number 08164-90B14).

NOTE

Please note that User Guides no longer contain programming information, and must now be used in conjunction with this manual.

Refer to the books listed on page 16 for additional information about the General Purpose Interface Bus, GPIB.

Table of Contents

The Structure of this Manual	5
Conventions used in this Manual	5
Related Manuals	6
Introduction to Programming	15
<hr/>	
 GPIB Interface	16
Returning the Instrument to Local Control	18
 Message Queues	19
How the Input Queue Works	20
Clearing the Input Queue	20
The Output Queue	21
The Error Queue	22
 Programming and Syntax Diagram Conventions	23
Short Form and Long Form	24
Command and Query Syntax	25
Units	25
Data Types	26
Slot and Channel Numbers	26
Laser Selection Numbers	27
 Common Commands	29
Common Command Summary	30
Common Status Information	31
 The Status Model	33
Status Registers	33
Status System for 8163A/B & 8164A/B	35
Status System for 8166A/B	36
Annotations	37
Status Byte Register	37
Standard Event Status Register	37
Operation/Questionable Status Summary	37
Operation/Questionable Status Summary Register	38
Operation/Questionable Slot Status	38
Operation Slot Status Register	38
Questionable Slot Status Register	38
Status Command Summary	40
Other Commands	41

Specific Commands	43
Specific Command Summary	44
Instrument Setup and Status	55
IEEE-Common Commands	56
Status Reporting – The STATus Subsystem	64
Interface/Instrument Behaviour Settings – The SYSTem Subsystem	76
Measurement Operations & Settings	79
Root Layer Command	80
Measurement Functions – The SENSE Subsystem	85
Agilent 81635A and Agilent 81619A- Master and Slave Channels	85
Signal Generation – The SOURce Subsystem	113
Signal Conditioning	148
The INPut and OUTput commands	148
The table of wavelength-dependent offsets	159
Compatibility of the 81560A/1A/6A/7A modular attenuator family to the 8156A attenuator	165
Slot Numbers	165
Command Semantic	166
Display and System Commands	167
IEEE Commands	167
Status Commands	168
User Calibration Data	168
Signal Routing	169
Triggering - The TRIGger Subsystem	171
Extended Trigger Configuration	179
Extended Trigger Configuration Example	182
Mass Storage, Display, and Print Functions	185
Display Operations – The DISPlay Subsystem	186

VISA Programming Examples	189
<hr/>	
How to Use VISA Calls	190
How to Set up a Fixed Laser Source	192
How to Measure Power using FETCh and READ	195
How to Co-ordinate Two Modules	199
How Power Varies with Wavelength	203
How to Log Results	207
The Agilent 816x VXIplug&play Instrument Driver	213
<hr/>	
Installing the Agilent 816x Instrument Driver	214
Using Visual Programming Environments	218
Getting Started with Agilent VEE	218
GPIB Interfacing in Agilent VEE	218
Getting Started with LabView	221
Getting Started with LabWindows	224
Features of the Agilent 816x Instrument Driver	225
Directory Structure	226
Opening an Instrument Session	227
Closing an Instrument Session	228
VISA Data Types and Selected Constant Definitions	229
Error Handling	230
Introduction to Programming	232
Example Programs	232
VISA-Specific Information	232
Instrument Addresses	232
Callbacks	232
Development Environments	232
Microsoft Visual C++ 4.0 (or higher) and Borland C++ 4.5 (or higher)	232
Microsoft Visual Basic 4.0 (or higher)	233
Agilent VEE 5.01 (or higher)	233
LabWindows CVI/ (R) 4.0 (or higher)	233
Online Information	234
Lambda Scan Applications	235
Equally Spaced Datapoints	236

How to Perform a Lambda Scan Application	237
The Prepare Lambda Scan Function	237
The Get Lambda Scan Parameters Function	238
The Execute Lambda Scan Function	238
How to Perform a Multi-Frame Lambda Scan Application	239
The Equally Spaced Datapoints Function	240
The Register Mainframe Function	240
The Unregister Mainframe Function	240
The Prepare Multi Frame Lambda Scan Function	241
The Get MF Lambda Scan Parameters Function	242
The Execute Multi Frame Lambda Scan Function	242
The Get Lambda Scan Result Function	242
The Get Number of PWM Channels Function	243
The Get Channel Location Function	243
GPIB Command Compatibility List	245
<hr/>	
Compatibility Issues	246
GPIB Bus Compatibility	246
Status Model	247
Preset Defaults	248
Removed Command	249
Obsolete Commands	250
Changed Parameter Syntax and Semantics	251
Changed Query Result Values	252
Timing Behavior	253
Error Handling	254
Command Order	255
Instrument Status Settings	256
Error Codes	257
<hr/>	
GPIB Error Strings	258
Index	271
<hr/>	

List of Figures

Figure 1	Remote Control	18
Figure 2	The Event Status Bit	31
Figure 3	The Registers and Filters for a Node	33
Figure 4	The Operational/Questionable Status System for 8163A/B & 8164A/B	35
Figure 5	The Operational/Questionable Status System for 8166A/B	36
Figure 6	Extrapolation and interpolation of attenuator module λ offset table	159
Figure 7	Extended Trigger Configuration	180
Figure 8	Setup for Extended Trigger Configuration Example	182
Figure 9	Non-Administrator Installation Pop-Up Box	215
Figure 10	Welcome Screen	215
Figure 11	Customizing Your Setup	216
Figure 12	Program Folder Item Options	217
Figure 13	Device Configuration	219
Figure 14	Advanced Device Configuration - Plug&play Driver	219
Figure 15	Search for GPIB Instruments	221
Figure 16	FP Conversion Options Box	222
Figure 17	Windows 95 and Windows NT VXIPNP Directory Structure	226
Figure 18	Equally Spaced Datapoints	236
Figure 19	Lambda Scan Operation Setup	237
Figure 20	Multi Frame Lambda Scan Operation Setup	239



List of Tables

Table 1	GPIB Capabilities	17
Table 2	Units and allowed Mnemonics	25
Table 3	Common Command Summary	30
Table 4	Specific Command Summary	44
Table 5	Commands that can only be configured using the master channel ..	85
Table 6	Commands that are independent for both master and slave channels	86
Table 7	Comparison of command semantics between 8156A attenuator and 8156xA modular attenuator family.	166
Table 8	Triggering and Power Measurements	171
Table 9	Generating Output Triggers from Power Measurements	172
Table 10	Incompatible GPIB Bus Commands	246
Table 11	Removed Commands	249
Table 12	Obsolete Commands	250
Table 13	Commands with Different Parameters or Syntax	251
Table 14	Queries with Different Result Values	252
Table 15	Timing Behavior Changes	253
Table 16	Error Handling Changes	254
Table 17	Specific Errors	254
Table 18	Overview for Supported Strings	258
Table 19	Overview for Unsupported Strings	270



1

Introduction to Programming

This chapter gives general information on how to control your instrument remotely.

Descriptions for the actual commands for the instruments are given in the following chapters. The information in these chapters is specific to the Agilent 8163A/B Lightwave Multimeter, Agilent 8164A/B Lightwave Measurement System, and Agilent 8166A/B Lightwave Multichannel System and assumes that you are already familiar with programming the GPIB.

GPIB Interface	-16
Setting the GPIB Address	-17
Returning the Instrument to Local Control	-18
Message Queues	-19
How the Input Queue Works	-20
The Output Queue	-21
The Error Queue	-22
Programming and Syntax Diagram Conventions	-23
Short Form and Long Form	-24
Command and Query Syntax	-25
Common Commands	-29
Common Command Summary	-30
Common Status Information	-31
The Status Model	-33
Status Registers	-33
Status System for 8163A/B & 8164A/B	-35
Status System for 8166A/B	-36
Annotations	-37
Status Command Summary	-40
Other Commands	-41

GPIB Interface

The interface used by your instrument is the GPIB (General Purpose Interface Bus).

GPIB is the interface used for communication between a controller and an external device, such as the tunable laser source. The GPIB conforms to IEEE standard 488-1978, ANSI standard MC 1.1 and IEC recommendation 625-1.

If you are not familiar with the GPIB, then refer to the following books:

- The International Institute of Electrical and Electronics Engineers. *IEEE Standard 488.1-1987, IEEE Standard Digital Interface for Programmable Instrumentation*. New York, NY, 1987
- The International Institute of Electrical and Electronics Engineers. *IEEE Standard 488.2-1987, IEEE Standard Codes, Formats, Protocols and Common Commands For Use with ANSI/IEEE Std 488.1-1987*. New York, NY, 1987

To obtain a copy of either of these last two documents, write to:

The Institute of Electrical and Electronics Engineers, Inc.
345 East 47th Street
New York, NY 10017
USA.

In addition, the commands not from the IEEE-488.2 standard, are defined according to the Standard Commands for Programmable Instruments (SCPI).

For information about SCPI, and SCPI programming techniques, please refer to:

- The SCPI Consortium: *Standard Commands for Programmable Instruments*. To obtain a copy of this manual, contact the following address:

SCPI Consortium Office
Bode Enterprise
2515 Camino del Rio South, Suite 340
San Diego, CA, 92108
USA

Web: <http://www.scpiconsortium.org>

The interface of the Agilent 8163A/B Lightwave Multimeter, Agilent 8164A/B Lightwave Measurement System, and Agilent 8166A/B Lightwave Multichannel System to the GPIB is defined by the IEEE Standards 488.1 and 488.2.

Table 1 shows the interface functional subset that the instruments implement.

Table 1 GPIB Capabilities

Mnemonic	Function
SH1	Complete source handshake capability
AH1	Complete acceptor handshake capability
T6	Basic talker; serial poll; no talk only mode; unaddressed to talk if addressed to listen
L4	Basic listener; no listen only mode; unaddressed to listen if addressed to talk
SR0	No service request capability
RL1	Complete remote/local capability
PP0	No parallel poll capability
DC1	Complete device clear capability
DT0	No device trigger capability
C0	No controller capability.

Setting the GPIB Address

There are two ways to set the GPIB address:

- You can set the GPIB address by using the command `“:SYSTem:COMMunicate:GPIB[:SELF]:ADDRESS”` on page 78.
- You can set the GPIB address from the front panel. See your instrument’s *User’s Guide* for more information.

The default GPIB address is 20.

NOTE

GPIB address 21 is often applied to the GPIB controller. If so, 21 cannot be used as an instrument address.

Returning the Instrument to Local Control

If the instrument is in remote control, a screen resembling Figure 1 will appear. Press [Local] if you wish to return the instrument to local control.

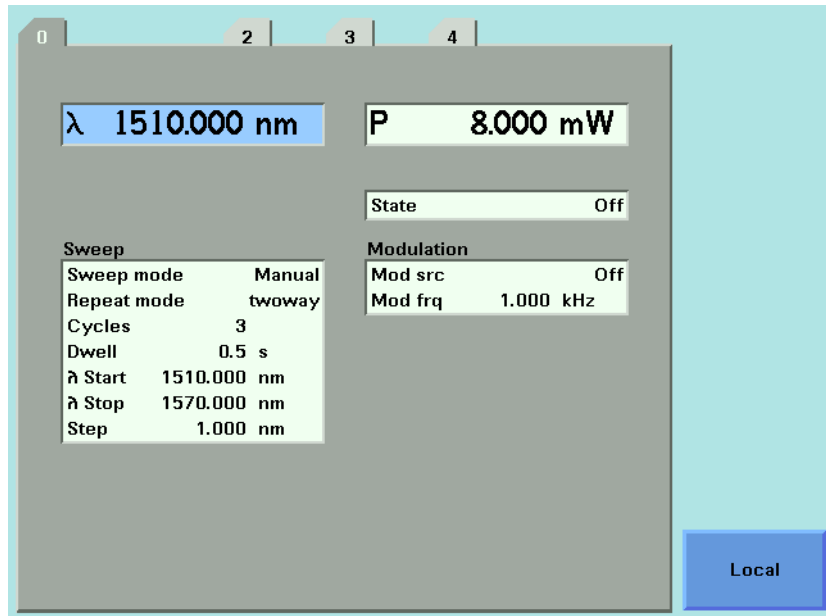

Figure 1 Remote Control

NOTE

If your Agilent 8163A/B, 8164A/B or 8166A/B is in local lockout mode (refer to DISPLAY:LOCKOut on page 142) the Local softkey is not available.

Message Queues

The instrument exchanges messages using an input and an output queue. Error messages are kept in a separate error queue.

How the Input Queue Works

The input queue is a FIFO queue (first-in first-out). Incoming bytes are stored in the input queue as follows:

- 1 Receiving a byte:
 - Clears the output queue.
 - Clears Bit 7 (MSB).
- 2 No modification is made inside strings or binary blocks. Outside strings and binary blocks, the following modifications are made:
 - Lower-case characters are converted to upper-case.
 - The characters 00_{16} to 09_{16} and $0B_{16}$ to $1F_{16}$ are converted to spaces (20_{16}).
 - Two or more blanks are truncated to one.
- 3 An EOI (End Or Identify) sent with any character is put into the input queue as the character followed by a line feed (LF, $0A_{16}$). If EOI is sent with a LF, only one LF is put into the input queue.
- 4 The parser starts if the LF character is received or if the input queue is full.

Clearing the Input Queue

Switching the power off, or sending a Device Interface Clear signal, causes commands that are in the input queue, but have not been executed to be lost.

The Output Queue

The output queue contains responses to query messages. The instrument transmits any data from the output queue when a controller addresses the instrument as a talker.

Each response message ends with a carriage return (CR, $0D_{16}$) and a LF ($0A_{16}$), with EOI=TRUE. If no query is received, or if the query has an error, the output queue remains empty.

The Message Available bit (MAV, bit 4) is set in the Status Byte register whenever there is data in the output queue.

The Error Queue

The error queue is 30 errors long. It is a FIFO queue (first-in first-out). That is, the first error read is the oldest error to have occurred. For example:

- 1** If no error has occurred, the error queue contains:
+ 0, "No error"
- 2** After a command such as wav:pow, the error queue now contains:
+ 0, "No error"
-113, "Undefined header"
- 3** If the command is immediately repeated, the error queue now contains:
+ 0, "No error"
-113, "Undefined header"
-113, "Undefined header"

If more than 29 errors are put into the queue, the message:

-350, "Queue overflow"

is placed as the last message in the queue.

Programming and Syntax Diagram Conventions

A program message is a message containing commands or queries that you send to the instruments. The following are a few points about program messages:

- You can use either upper-case or lower-case characters.
- You can send several commands in a single message. Each command must be separated from the next one by a semicolon (;).
- A command message is ended by a line feed character (LF) or <CR><LF>.
- You can use any valid number/unit combination.

In other words, 1500NM, 1.5UM and 1.5E-6M are all equivalent.

If you do not specify a unit, then the default unit is assumed. The default unit for the commands are given with command description in the next chapter.

Short Form and Long Form

The instrument accepts messages in short or long forms.

For example, the message

```
:STATUS:OPERATION:ENABLE 768
```

is in long form.

The short form of this message is

```
:STAT:OPER:ENAB 768
```

In this manual, the messages are written in a combination of upper and lower case. Upper case characters are used for the short form of the message.

For example, the above command would be written

```
:STATus:OPERation:ENABle
```

The first colon can be left out for the first command or query in your message. That is, the example given above could also be sent as

```
STAT:OPER:ENAB 768
```

Command and Query Syntax

All characters not between angled brackets must be sent exactly as shown.

The characters between angled brackets (<...>) indicate the kind of data that you should send, or that you get in a response. You do not type the angled brackets in the actual message.

Descriptions of these items follow the syntax description. The following types of data are most commonly used:

string	is ascii data. A string is contained between double quotes ("...") or single quotes ('...').
value	is numeric data in integer (12), decimal (34.5) or exponential format (67.8E-9).
wsp	is a white space.

Other kinds of data are described as required.

The characters between square brackets ([...]) show optional information that you can include with the message.

The bar (|) shows an either-or choice of data, for example, $a | b$ means either a or b , but not both simultaneously.

Extra spaces are ignored, so spaces can be inserted to improve readability.

Units

Where units are given with a command, usually only the base units are specified. The full sets of units are given in the table below.

Table 2 Units and allowed Mnemonics

Unit	Default	Allowed Mnemonics
meters	M	PM, NM, UM, MM, M
decibel	DB	MDB, DB
second	S	NS, US, MS, S
decibel/1mW	DBM	MDBM, DBM
Hertz	HZ	HZ, KHZ, MHZ, GHZ, THZ
Watt	Watt	PW, NW, UW, MW, Watt
meters per second	M/S	NM/S, UM/S, MM/S, M/S

Data Types

With the commands you give parameters to the instrument and receive response values from the instrument. Unless explicitly specified these data are given in ASCII format. The following types of data are used:

- **Boolean** data may only have the values 0 or 1.
- **Integer** range is given for each individual command.
- **Float** variables may be given in decimal or exponential writing (0.123 or 123E-3).
All **Float** values conform to the 32 bit IEEE Standard, that is, all **Float** values are returned as 32-bit real values.
- A **string** is contained between double quotes ("...") or single quotes ('...'). When the instrument returns a string, it is always included in " " and terminated by <END>.
- When a **register** value is given or returned (for example *ESE), the **decimal** values for the single bits are added. For example, a value of nine means that bit 0 and bit 3 are set.
- Larger blocks of data are given as **Binary Blocks**, preceded by "#<H><Len><Block>", terminated by <END>; <H> represents the number of digits, <Len> represents the number of bytes, and <Block> is the data block. For example, for a **Binary Block** with 1 digit and 6 bytes this is: #16TRACES<END>.

Slot and Channel Numbers

Each module is identified by a slot number and a channel number. For commands that require you to specify a channel, the slot number is represented by [n] in a command and the channel number is represented by [m].

The slot number represents the module's position in the mainframe. These are:

- from one to two for the Agilent 8163A/B,
- from zero to four for the Agilent 8164A/B, and
- from one to seventeen for the Agilent 8166A/B.

These numbers are displayed on the front panel beside each module slot.

NOTE

The Agilent 8164A/B slot for a back-loadable tunable laser module is numbered zero.

Channel numbers apply to modules that have two inputs/outputs, for example, the Agilent 81635A Dual Power Sensor.

Modules with two channels, for example, the Agilent 81635A Dual Power Sensor, use the channel number to distinguish between these channels.

NOTE

The channel number of single channel modules is always one.

For example, if you want to query slot 1, channel 2 with the command, *“:SENSe[n]:[CHANnel[m]]:POWer:WAVelength?”* on page 109, you should send the command:

- `:sens1:chan2:pow:wav?`

NOTE

If you do not specify a slot or channel number, the lowest possible number is used as the default value. This means:

- Slot 1 for the Agilent 8163A/B and Agilent 8166A/B mainframes.
 - Slot 0 for the Agilent 8164A/B mainframe.
 - Channel 1 for all channels.
-

Laser Selection Numbers

The laser selection number, *[l]*, identifies the upper or lower wavelength laser source for dual wavelength Laser Source modules and Return Loss modules with two internal laser sources. The lower wavelength source is denoted by *1*. The upper wavelength source is denoted by *2*.

NOTE

For Return Loss modules, θ denotes the use of an external laser source as the input to your Return Loss module for the following commands:

- “:SENSe[n]:[CHANnel[m]]:RETurnloss:CORRection:FPDelta[l]” on page 111,
 - “:SENSe[n]:[CHANnel[m]]:RETurnloss:CORRection:FPDelta[l]?” on page 111,
 - “:SENSe[n]:[CHANnel[m]]:RETurnloss:CORRection:REFlectance[l]” on page 112, and
 - “:SENSe[n]:[CHANnel[m]]:RETurnloss:CORRection:FPDelta[l]” on page 111.
-

Common Commands

The IEEE 488.2 standard has a list of reserved commands, called common commands. Some of these commands must be implemented by any instrument using the standard, others are optional.

Your instrument implements all the necessary commands, and some optional ones. This section describes the implemented commands.

Common Command Summary

Table 3 gives a summary of the common commands.

Table 3 Common Command Summary

Command	Parameter	Function	Page
*CLS		Clear Status Command	page 57
*ESE		Standard Event Status Enable Command	page 57
*ESE?		Standard Event Status Enable Query	page 58
*ESR?		Standard Event Status Register Query	page 58
*IDN?		Identification Query	page 59
*OPC		Operation Complete Command	page 59
*OPC?		Operation Complete Query	page 60
*OPT?		Options Query	page 60
*RST		Reset Command	page 61
*STB?		Read Status Byte Query	page 61
*TST?		Self Test Query	page 62
*WAI		Wait Command	page 63

NOTE

These commands are described in more detail in “*IEEE-Common Commands*” on page 56.

Common Status Information

There are three registers for the status information. Two of these are status-registers and one is an enable-registers. These registers conform to the IEEE Standard 488.2-1987. You can find further descriptions of these registers under *ESE, *ESR?, and *STB?.

Figure 2 shows how the Standard Event Status Enable Mask (SESEM) and the Standard Event Status Register (SESR) determine the Event Status Bit (ESB) of the Status Byte.

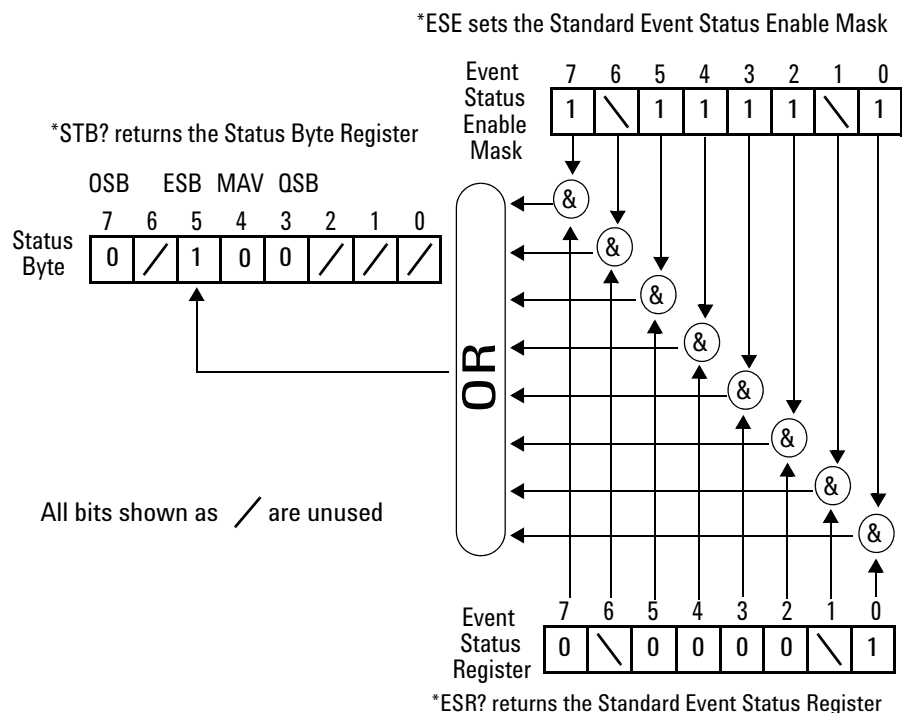

Figure 2 The Event Status Bit

The SESR contains the information about events that are not slot specific. For details of the function of each bit of the SESR, see *“Standard Event Status Register”* on page 37.

The SESEM allows you to choose the event that may affect the ESB of the Status Byte. If you set a bit of the SESEM to zero, the corresponding event cannot affect the ESB. The default is for all the bits of the SESEM to be set to 0.

The questionable and operation status systems set the Operational Status Bit (OSB) and the Questionable Status Bit (QSB). These status systems are described in *“The Status Model”* on page 33 and *“Status Reporting – The STATus Subsystem”* on page 64.

NOTE

Unused bits in any of the registers change to 0 when you read them.

The Status Model

Status Registers

Each node of the status circuitry has three registers:

- A condition register (CONDition), which contains the current status. This register is updated continuously. It is not changed by having its contents read.
- The event register (EVENT), which contains details of any positive transitions in the corresponding condition register, that is, when a bit changes from 0 → 1. The contents of this register are cleared when it is read. The contents of any higher-level registers are affected with regard to the appropriate bit.
- The enable register (ENABLE), which enables changes in the event register to affect the next stage of registers.

NOTE

The event register is the only kind of register that can affect the next stage of registers.

The structures of the Operational and Questionable Status Systems are similar. Figure 4 describe how the Questionable Status Bit (QSB) and the Operational Status Bit (OSB) of the Status Byte Register are determined.

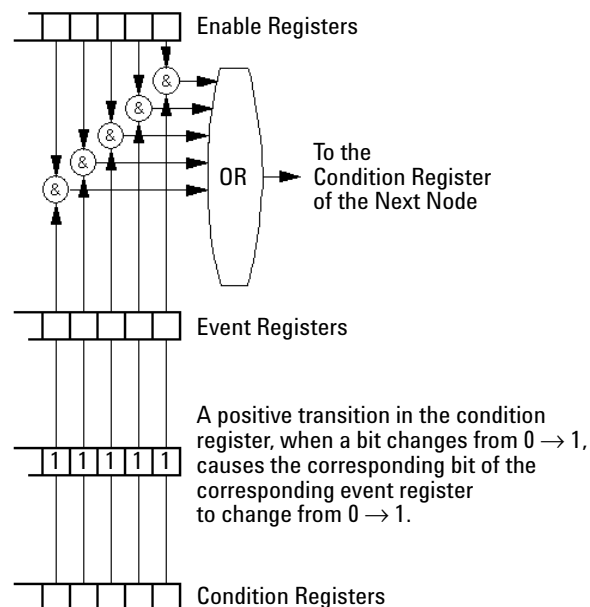

Figure 3 The Registers and Filters for a Node

The Operational/Questionable Slot Status Event Register (OSSER/QSSER) contains the status of a particular module slot. A bit changes from 0 → 1 when an event occurs, for example, when a laser is switched on. For details of the function of each bit of these registers, see *“Operation/Questionable Status Summary Register” on page 38.*

The Operational/Questionable Slot Enable Status Mask (OSESME/QSESM) allows you to choose the events for each module slot that may affect the Operational/Questionable Status Event Register (see below). If you set a bit of the OSESME/QSESM to zero, the occurrence of the corresponding event for this particular module slot cannot affect the Operational/Questionable Status Event Register. The default is for all the bits of the OSESME/QSESM to be set to 0.

The Operational/Questionable Status Event Summary Register (OSESRE/QSESRE) summarizes the status of every module slot of your instrument. If, for any slot, any bit of the QSSER goes from 0 → 1 AND the corresponding bit of the QSESM is 1 at the same time, the QSESRE bit representing that slot is set to 1.

The Operational/Questionable Status Enable Summary Mask (OSESME/QSESM) allows you to choose the module slots that may affect the OSB/QSB of the Status Byte. If any bit of the QSESRE goes from 0 → 1 AND the corresponding bit of the QSESM is 1 at the same time, the QSB of the Status Byte is set to 1. If you set a bit of the OSESME/QSESM to zero, the corresponding module slot cannot affect the OSB/QSB. The default is for all the bits of the OSESME/QSESM to be set to 0.

The Operational/Questionable Status Enable Summary Mask for the Agilent 8163A/B Lightwave Multimeter and the Agilent 8164A/B Lightwave Measurement System consists of one level. These are described in *“Status System for 8163A/B & 8164A/B” on page 35.*

As the Agilent 8166A/B Lightwave Multichannel System has 17 module slots, the Operational/Questionable Status Enable Summary Mask consists of two levels. This is described in *“Status System for 8166A/B” on page 36.*

Status System for 8163A/B & 8164A/B

The status system for the Agilent 8163A/B Lightwave Multimeter and the Agilent 8164A/B Lightwave Measurement System returns the status of 2 and 5 module slots respectively. The Operational/Questionable Status Summary Registers consist of one level and are described by Figure 4 . Any commands that require LEVEL1 do not apply to these mainframes.

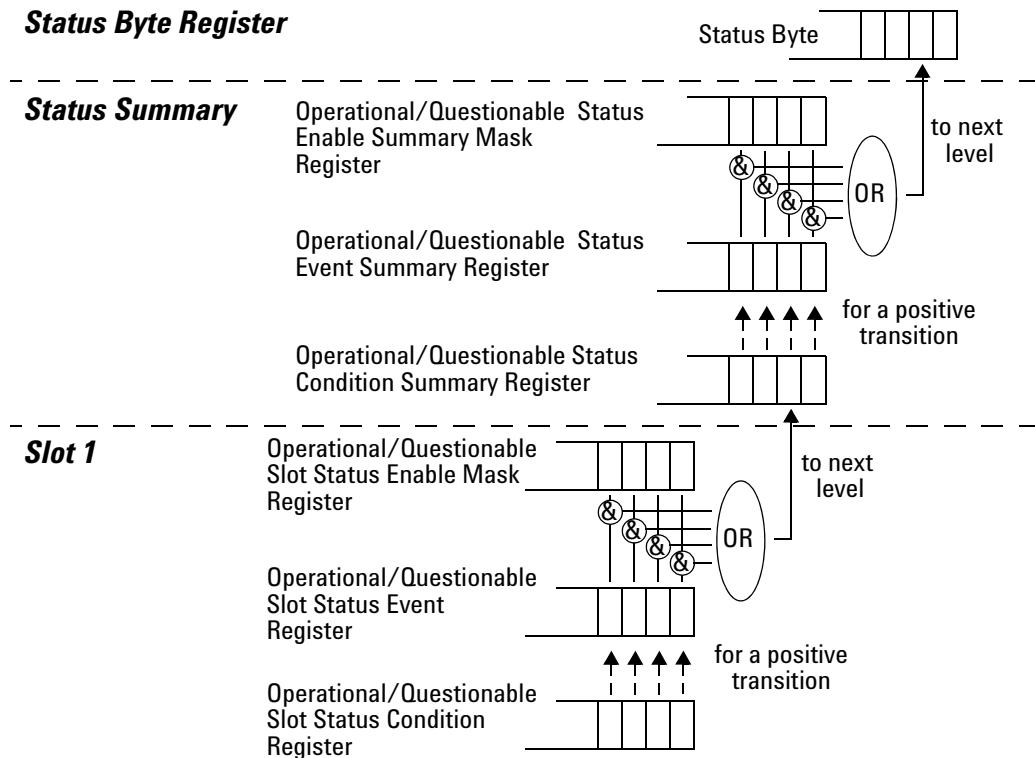

Figure 4 The Operational/Questionable Status System for 8163A/B & 8164A/B

Status System for 8166A/B

The status system for the Agilent 8166A/B Lightwave Multichannel System returns the status of 17 module slots. The Operational/Questionable Status Summary Registers consists of two levels, as described by Figure 5 .

Module slots 1 to 14 affect the Level 0 summary register as described in Figure 4 . Bit 0 of the Level 0 summary registers represents the summary of the status of module slots 15, 16, and 17. The Level 1 summary registers contain an individual summary for each of these module slots.

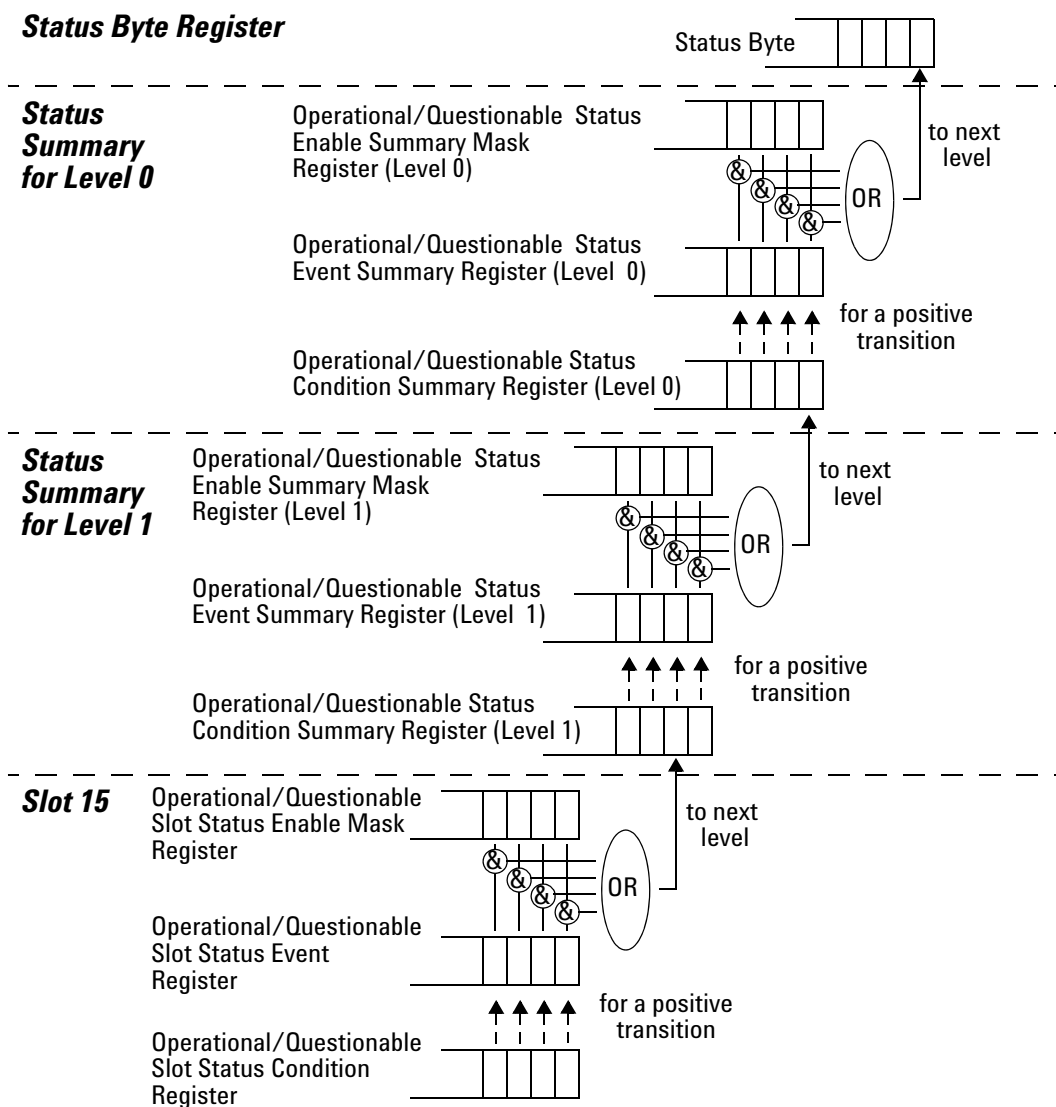

Figure 5 The Operational/Questionable Status System for 8166A/B

Annotations

Status Byte Register

- Bit 3, the QSB, is built from the questionable event status register and its enable mask.
- Bit 4, the MAV, is set if the message output queue is not empty.
- Bit 5, the ESB, is built from the SESR and its SESEM.
- Bit 7, the OSB, is built from the operation event status register and its enable mask.
- All other bits are unused, and therefore set to 0.

Standard Event Status Register

- Bit 0 is set if an operation complete event has been received since the last call to *ESR?.
- Bit 1 is always 0 (no service request).
- Bit 2 is set if a query error has been detected.
- Bit 3 is set if a device dependent error has been detected.
- Bit 4 is set if an execution error has been detected.
- Bit 5 is set if a command error has been detected.
- Bit 6 is always 0 (no service request).
- Bit 7 is set for the first call of *ESR? after Power On.

Operation/Questionable Status Summary

- The Operation/Questionable Status Summary consist of a condition and an event register.
- A "rising" bit in the condition register is copied to the event register.
- A "falling" bit in the condition register has no effect on the event register.
- Reading the condition register is non-destructive.
- Reading the event register is destructive.
- A summary of the event register and its enable mask is set in the status byte.

Operation/Questionable Status Summary Register

- Bits 0 to 4 are built from the OSSER/QSSER and the OSSEM/QSSEM.
- A summary of the event register, the condition register and the enable mask is set in the status byte.

Operation/Questionable Slot Status

- The Operation/Questionable Slot Status consist of a condition and an event register.
- A "rising" bit in the condition register is copied to the event register.
- A "falling" bit in the condition register has no effect on the event register.
- Reading the condition register is non-destructive.
- Reading the event register is destructive.
- A summary of the event register, the condition register and the enable mask is set in the status byte.

Operation Slot Status Register

- Bit 0 is set if the laser is switched on.
- Bit 1 is set if the Coherence Control is switched on.
- Bit 3 is set if Power Meter zeroing or Tunable Laser module lambda zeroing is ongoing.
- Bit 4 is set if the attenuator output is enabled (shutter open).
- Bits 5 - 7 are set if the wavelength offset table is enabled (see page 68).
- All other bits are unused, and therefore set to 0.

Questionable Slot Status Register

- Bit 0 is set if excessive power is set by the user for any source module or if excessive averaging time is set for any Power Meter.
- Bit 1 is set if the last Power Meter zeroing failed.
- Bit 2 is set if temperature is out of range.
- Bit 3 is set if laser protection is switched on.

- Bit 4 is set if the module has not settled, as during the automatic settling of a Tunable Laser module.
- Bit 5 is set if the module is out of specifications, or if lambda zeroing failed for a Tunable Laser module.
- Bit 6 is set if ARA is recommended.
- Bit 7 is set if the duty cycle is out of range.
- Bit 8 is set if coherence control is uncalibrated
- Bit 9 is set if attenuator beam path protection is enabled (shutter is closed)
- Bit 10 is set if lambda zeroing is recommended.
- All other bits are unused, and therefore set to 0.

Status Command Summary

*STB?	returns status byte, value 0 .. +255
*ESE	sets the standard event status enable mask, parameter 0 .. +255
*ESE?	returns SESE, value 0 .. +255
*ESR?	returns the standard event status register, value 0 .. +255
*OPC	parses all program message units in the message queue, and prevents the instrument from executing any further commands until all pending commands are completed.
*OPC?	returns 1 if all operations (scan trace printout, measurement) are completed. Otherwise it returns 0.
*CLS	clears the status byte and SESR, and removes any entries from the error queue.
*RST	clears the error queue, loads the default setting, and restarts communication. NOTE: *RST does NOT touch the STB or SESR. A running measurement is stopped.
*TST?	initiates an instrument selftest and returns the results as a 32 bit LONG.

Other Commands

*OPT?	returns the installed modules and the slots these modules are installed in: For example, *OPT? → 81682A, 81533B, 81532A, , Modules 81682A, 81533B, and 81532A are installed in slots 0 to 2 respectively. Slots 3 and 4 are empty.
*WAI	prevents the instrument from executing any further commands until the current command has finished executing. All pending operations are completed during the wait period.
*IDN?	identifies the instrument; returns the manufacturer, instrument model number, serial number, and firmware revision level.



2

Specific Commands

This chapter lists all the instrument specific commands relating to the Agilent 8163A/B Lightwave Multimeter, the Agilent 8164A/B Lightwave Measurement System, and the Agilent 8166A/B Lightwave Multichannel System with a single-line description.

Each of these summaries contains a page reference for more detailed information about the particular command later in this manual.

Specific Command Summary -44

Specific Command Summary

The commands are ordered in a command tree. Every command belongs to a node in this tree.

The root nodes are also called the subsystems. A subsystem contains all commands belonging to a specific topic. In a subsystem there may be further subnodes.

All the nodes have to be given with a command. For example in the command `disp:brig`

- `DISPlay` is the subsystem containing all commands for controlling the display,
- `BRIGhtness` is the command selecting brightness.

NOTE

If a command and a query are both available, the command ends `/?`. So, `disp:brig/?` means that `disp:brig` and `disp:brig?` are both available.

Table 4 gives an overview of the command tree. You see the nodes, the subnodes, and the included commands.

Table 4 Specific Command Summary

Command	Description	Page
:CONFigure[<i>n</i>][:CHANnel[<i>m</i>]:OFFSet		
:WAVelength:REFeRence/?	Sets or queries the slot and channel of the external reference powermeter.	page 161
:WAVelength:STATe/?	Switches or queries attenuator Offset Table on or off/?	page 160
:WAVelength:TABLe?	Queries the complete offset table.	page 164
:WAVelength:TABLe:SIZE?	Queries the size of the offset table.	page 164
:WAVelength:VALue	Adds a value pair (wavelength, offset) to the offset table.	page 161
:WAVelength:VALue:DELeTe	Deletes an offset value pair.	page 163
:WAVelength:VALue:DELeTe:ALL	Deletes all value pairs from the offset table.	page 163
:WAVelength:VALue:OFFSet?	Queries an offset value according to wavelength or index.	page 162
:WAVelength:VALue:PAIR?	Queries an offset/wavelength value pair according to wavelength or index.	page 163
:WAVelength:VALue:WAVelength?	Queries a wavelength value from its index in the offset table	page 162

Table 4 Specific Command Summary (continued)

Command	Description	Page
:DISPlay		
:BRiGhtness/?	Controls or queries the current display brightness.	page 186
:CONTrast/?	Controls or queries the current display contrast.	page 186
:ENABle/?	Switches the display on or off, or queries whether the display is on or off.	page 187
:LOCKout/?	Sets or queries local lockout mode.	page 187
:FETCh[n][:CHANnel[m]][:SCALar]		
:POWer[:DC]?	Returns a power value from a sensor.	page 87
:RETurnloss?	Returns the current return loss value.	page 87
:MONitor?	Returns the current power value from the monitor diode within a return loss module.	page 88
:INITiate[n][:CHANnel[m]]		
[:IMMEDIATE]	Starts a measurement.	page 88
:CONTinuous/?	Starts or Queries a single/continuous measurement.	page 89
:LOCK/?	Switches the lock on/off or returns the current state of the lock.	page 80
:INPUT[n][:CHANnel[m]]		
:ATTenuation/?	Sets or returns the attenuation factor for the instrument.	page 148
:OFFset/?	Sets or returns the offset factor for the instrument.	page 149
:OFFset:DISPlay	Sets the offset factor so that attenuation factor is zero.	page 149
:OFFset:POWermeter	Sets the offset factor to the difference between the power measured with a powermeter and with the monitor diode.	page 150
:ATTenuation:SPEed/?	Sets or queries the filter transition speed	page 150
:WAVelength/?	Sets or queries the modules attenuation wavelength	page 151
:OUTPut[n][:CHANnel[m]]		
:APMode/?	Sets or queries whether power setting or attenuation value has been changed.	page 151
:APOWeron/?	Sets or queries the shutter status at power on.	page 157
:ATIMe/?	Sets or queries the powermeter averaging time.	page 157
:CONNection/?	Selects or returns Analog Output parameter.	page 113
:CORRection:COLLection:ZERO	Zeros the offsets of attenuators powermeter	page 157
:CORRection:COLLection:ZERO:ALL	Zeros all available powermeter channels in mainframe	page 158

Table 4 Specific Command Summary (continued)

Command	Description	Page
:CORRection:COLLection:ZERO?	Queries the status of the last zero operation	page 158
:PATH/?	Sets or returns the regulated path.	page 113
:POWer/?	Sets or queries the output power value.	page 152
:POWer:CONTRol/?	Sets or queries power control mode status	page 155
:POWer:OFFSet/?	Sets or queries the power offset value.	page 154
:POWer:OFFSet:POWermeter	Calculates power offset from measured power values	page 154
:POWer:REFErence/?	Sets or queries the reference power value.	page 153
:POWer:REFErence:POWermeter	Copies power value from power meter to attenuator module ref. power parameter	page 153
:POWer:UNit/?	Sets or queries power unit used (dBm or W)	page 155
[:STATe]/?	Sets a source's or attenuators output terminals to open or closed or returns the current status of a source's or attenuators output terminals.	page 114
:READ[n][:CHANnel[m]]		
[:SCALar]:POWer[:DC]?	Reads the current power value from a sensor.	page 89
:POWer[:DC]:ALL?	Reads all available power meter channels.	page 90
:POWer[:DC]:ALL:CONFig?	Return all the slot and channel number of every available power meter channel.	page 90
[:SCALar]:RETurnloss?	Reads the current return loss value.	page 91
[:SCALar]:MONitor?	Returns the current power value from the monitor diode within a return loss module.	page 91
:ROUTe[n]		
[:CHANnel[m]]/?	Sets or returns the channel route between two ports.	page 169
[:CHANnel[m]]:CONFig?	Reads the switch configuration of an instrument.	page 170
[:CHANnel[m]]:CONFig:ROUTe?	Reads the allowed switch routes of an instrument.	page 170

Table 4 Specific Command Summary (continued)

Command	Description	Page
:SENSe[n]:CHANnel[m]:CORRection		
[:LOSS][:INPut][:MAGNitude]/?	Sets or returns the value of correction data for a sensor.	page 92
:COLLECT:ZERO	Executes a zero calibration of a sensor module.	page 92
:COLLECT:ZERO?	Returns the current zero state of a sensor module.	page 93
:COLLECT:ZERO:ALL	Executes a zero calibration of all sensor modules.	page 93
:SENSe[n]:CHANnel[m]:FUNctIon		
:PARAmeter:LOGGing/?	Sets or returns the number of samples and the averaging time, t_{avg} , for logging.	page 94
:PARAmeter:MINMax/?	Sets or returns the minmax mode and the window size.	page 95
:PARAmeter:STABility/?	Sets or returns the total time, delay time and the averaging time, t_{avg} , for stability.	page 96
:RESult?	Returns the data array of the last function.	page 97
:RESult:BLOCK?	Returns a specified binary block from the data array for the last power meter data acquisition function.	page 98
:RESult:MAXBlockSize?	Returns the maximum block size for power meter data acquisition functions.	page 98
:RESult:MONitor?	For return loss module, returns monitor diode data array of last function.	page 99
:STATe/?	Enables/disables the function mode or returns whether the function mode is enabled.	page 100
:THReshold/?	Sets or returns the threshold value and the start mode.	page 101
:SENSe[n]:CHANnel[m]:POWer		
:ATIMe/?	Sets or returns the average time of a sensor.	page 101
:RANGe[:UPPer]/?	Sets or returns the most positive signal entry expected for a sensor.	page 102
:RANGe:MONitor[:UPPer]/?	Sets or returns the range of the monitor diode within a return loss module.	page 103
:RANGe:AUTO/?	Sets or returns the range of a sensor to produce the most dynamic range without overloading.	page 104
:REFerence/?	Sets or returns the reference level of a sensor.	page 105
:UNIT/?	Sets or returns the units used for absolute readings on a sensor.	page 108
:WAVelength/?	Sets or returns the wavelength for a sensor.	page 108

Table 4 Specific Command Summary (continued)

Command	Description	Page
:SENSe[n]:CHANnel[m]:POWer:Reference		
:DISPlay	Sets the reference level for a sensor from the input power level.	page 106
:STATe/?	Sets or returns whether sensor results are in relative or absolute units.	page 106
:STATe:RATio/?	Sets or returns whether sensor results are displayed relative to a channel or to an absolute reference.	page 106
:SENSe[n]:CHANnel[m]:RETurnloss:CALibration		
:FACTory	Sets the calibration value to factory settings.	page 109
:COLLect:REFlectance	Sets the reference reflectance calibration values to the values currently measured by the chosen return loss module. (When, for example, a gold reflector is used.)	page 109
:COLLect:TERMination	Sets the termination calibration values to the values currently measured by the chosen return loss module.	page 110
:COLLect:VALues?	Returns current calibration values.	page 110
:TERMination?	Returns T-Value	page 110
:SENSe[n]:CHANnel[m]:RETurnloss:CORRection		
:FPDelta[l]/?	Sets or returns front panel delta, that is, the loss correction value due, for example, to the front panel connector.	page 111
:REFlectance[l]/?	Sets or returns the return loss reference, the return loss value of your reference reflector.	page 112
:SLOT[n]		
:EMPTy?	Returns whether the module slot is empty.	page 81
:IDN?	Returns information about the module.	page 81
:OPTions?	Returns the module's options.	page 81
:TST?	Returns the latest selftest results for a module.	page 82
:SLOT[n]::HEAD[m]		
:EMPTy?	Returns whether an optical head is connected.	page 82
:IDN?	Returns information about the optical head.	page 82
:OPTions?	Returns the optical head's options.	page 83
:TST?	Returns the latest selftest results for an optical head.	page 83
:WAVelength:RESPonse?	Returns the wavelength response from the module with wavelength calibration.	page 83
:WAVelength:RESPonse:CSV?	Returns the wavelength response from the module with wavelength calibration.	page 84

Table 4 Specific Command Summary (continued)

Command	Description	Page
:WAVelength:RESponse:SIZE?	Returns the no. of elements in the wavelength response table.	page 84
[:SOURce[n]] [:CHANnel[m]]		
:MODout/?	Returns the mode of the modulation output mode of the BNC connector on the front panel of Agilent 81640A/80A/82A Tunable Laser modules.	page 121
[:SOURce[n]] [:CHANnel[m]] :AM		
[:INternal] :FREQUency[f]/?	Sets or returns the frequency of an internal signal source.	page 115
:SOURce[f]/?	Sets or returns a source for the modulating system.	page 116
:STATe[f]/?	Turns Amplitude Modulation of a source on or off or queries whether Amplitude Modulation is on or off.	page 117
:COHCtrl:COHLevel[l]/?	Sets or returns the coherence level.	page 118
[:SOURce[n]] [:CHANnel[m]] :FM		
:SOURce[f]/?	Sets or returns the type of frequency modulation employed, specifically Simulated Brillouin Scattering (SBS) control.	page 118
:STATe[f]/?	Turns Frequency Modulation of a source on or off or queries whether Frequency Modulation is on or off.	page 119
:SBSCtrl:FREQUency[f]/?	Sets or returns the frequency of SBS Control modulation.	page 120
:SBSCtrl:LEVel[f]/?	Sets or returns the level of SBS Control modulation (as a percentage of maximum)	page 120
[:SOURce[n]] [:CHANnel[m]] :POWER		
[:LEVel] [:IMMediate] [:AMPLitude[f]]	Sets the laser output power of a source.	page 124
[:LEVel] [:IMMediate] [:AMPLitude[f]] ?	Returns the laser output power of a source.	page 125
[:LEVel] :RISetime[f]/?	Sets or returns the laser rise time of a source.	page 126
:ATTenuation[f]/?	Sets or returns the attenuation level for a source.	page 122
:STATe/?	Sets or returns the state of the source output signal.	page 127
:UNIT/?	Sets or returns the power units.	page 127
:WAVelength/?	Sets or returns the wavelength source of a dual-wavelength source.	page 128
[:SOURce[n]] [:CHANnel[m]] :POWER:ATTenuation[f]		
:AUTO/?	Selects Automatic or Manual Attenuation Mode for a source or returns the selected mode.	page 123
:DARK/?	Enables/disables 'dark' position on a source or returns whether 'dark' position is active for a source.	page 123

Table 4 Specific Command Summary (continued)

Command	Description	Page
[[:SOURce[n]][:CHANnel[m]]:READout		
:DATA?	Returns number of datapoints returned by the [[:SOURce[n]][:CHANnel[m]]:READout:POINts? command.	page 129
:DATA:BLOCK?	Returns a specified binary block from either a lambda logging operation, or maximum power at wavelength characteristic.	page 129
:DATA:MAXBlockSize?	Returns the maximum blocksize that a lambda logging, or maximum power at wavelength characteristic will return.	page 129
:POINts?	Returns the data as a binary stream from either a lambda logging operation or the maximum power the laser can produce at each wavelength.	page 130
[[:SOURce[n]][:CHANnel[m]]:WAVelength		
[:CW[!]:FIXED]	Sets the absolute wavelength of a source.	page 130
[:CW[!]:FIXED[!]]?	Returns the absolute wavelength of a source.	page 131
:FREQuency[!]/?	Sets the frequency difference used to calculate a relative wavelength for a source.	page 134
:REFerence[!]/?	Returns the reference wavelength of a source.	page 135
[[:SOURce[n]][:CHANnel[m]]:WAVelength:CORRection		
:ARA	Realigns the laser cavity.	page 131
:ARA:ALL	Realigns the laser cavity of every tunable laser source in the mainframe.	page 132
:AUTocalib	Sets or returns tunable laser source Auto Calibration state.	page 132
:ZERO	Executes a wavelength zero.	page 132
:ZERO:ALL	Executes a wavelength zero on every tunable laser source in the mainframe.	page 133
:ZERO:TEMPerature:ACTual?	Reports the current lambda zero temperature	page 133
:ZERO:TEMPerature:DIFFerence?	Reports the temperature difference required to trigger an auto lamda zero.	page 134
:ZERO:TEMPerature:LASTzero?	Reports the temperature at which the last auto lamda zero took place.	page 134
:ZERO:AUTO	Forces an auto lamda zero. This is quicker than the equilibvent manual process.	page 134
[[:SOURce[n]][:CHANnel[m]]:WAVelength:REFerence		
:DISPlay	Sets the reference wavelength of a source to the value of the output wavelength.	page 135

Table 4 Specific Command Summary (continued)

Command	Description	Page
[:SOURce[n]][:CHANnel[m]] :WAVelength :SWEep		
:CHECKparams?	Returns whether sweep parameters set are consistent.	page 136
:CYCLes/?	Sets or returns the number of cycles.	page 137
:DWELI/?	Sets or returns the dwell time.	page 138
:EXPectedtriggers?	Returns number of triggers (used to configure power meter).	page 138
:FLAG?	Returns whether waiting for trigger, or logging data available.	page 139
:LLOGging/?	Switches lambda logging on or off or queries the state of lambda logging.	page 140
:MODE/?	Sets or returns the sweep mode.	page 141
:PMAx?	Returns the highest permissible power for a wavelength sweep.	page 141
:REPeat/?	Sets or returns the repeat mode.	page 142
:SOFTtrigger	Sends a soft trigger.	page 143
:SPEEd/?	Sets or returns the speed for continuous sweeping.	page 143
:STARt/?	Sets or returns the start point of the sweep.	page 144
:STOP/?	Sets or returns the end point of the sweep.	page 144
[:STATe]/?	Stops, starts, pauses or continues a wavelength sweep or returns the the state of a sweep.	page 145
[:SOURce[n]][:CHANnel[m]] :WAVelength :SWEep :STEP		
:NEXT	Performs the next sweep step.	page 146
:PREVious	Performs the previous sweep step again.	page 146
[:WIDTh]/?	Sets or returns the width of the sweep step.	page 146

Table 4 Specific Command Summary (continued)

Command	Description	Page
:SPECial		
:REBoot	Reboots the mainframe and all modules.	page 84
:STATus[n]		
:PRESet	Presets all Enable Registers.	page 69
:STATus:OPERation		
[:EVENT]?	Returns the Operational Status Event Summary Register (OESR).	page 68
[:EVENT]:LEVel1?	Returns the Operational Status Event Summary Register for slots 15 - 17 of the Agilent 8166A/B Lightwave Multichannel System.	page 66
:CONDition?	Returns the Operational Status Condition Summary Register.	page 68
:CONDition:LEVel1?	Returns the Operational Status Condition Summary Register for slots 15 - 17 of the Agilent 8166A/B Lightwave Multichannel System.	page 67
:ENABle/?	Sets or queries the Operational Status Enable Summary Mask.	page 69
:ENABle:LEVel1/?	Sets or queries the Operational Status Enable Summary Mask for slots 15 - 17 of the Agilent 8166A/B Lightwave Multichannel System.	page 67
:STATusn:OPERation		
[:EVENT]?	Returns the Operational Slot Status Event Register for slot <i>n</i> .	page 68
:CONDition?	Returns the Operational Slot Status Condition Register for slot <i>n</i> .	page 68
:ENABle/?	Sets or queries the Operation Slot Status Enable Mask for slot <i>n</i> .	page 69
:STATus:QUEStionable		
[:EVENT]?	Returns the Questionable Status Event Summary Register.	page 74
[:EVENT]:LEVel1?	Returns the Questionable Status Event Summary Register for slots 15 - 17 of the Agilent 8166A/B Lightwave Multichannel System.	page 72
:CONDition?	Returns the Questionable Status Condition Summary Register.	page 74
:CONDition:LEVel1?	Returns the Questionable Status Condition Summary Register for slots 15 - 17 of the Agilent 8166A/B Lightwave Multichannel System.	page 73
:ENABle/?	Sets or queries the Questionable Status Enable Summary Mask.	page 75
:ENABle:LEVel1/?	Sets or queries the Questionable Status Enable Summary Mask for slots 15 - 17 of the Agilent 8166A/B Lightwave Multichannel System.	page 73

Table 4 Specific Command Summary (continued)

Command	Description	Page
:STATus:n:QUEStionable		
:[EVENT]?	Returns the Questionable Slot Status Event Register for slot <i>n</i> .	page 74
:CONDition?	Returns the Questionable Slot Status Condition Register for slot <i>n</i> .	page 74
:ENABle/?	Sets or queries the Questionable Slot Status Enable Mask for slot <i>n</i> .	page 75
:SYSTem		
:DATE/?	Sets or returns the instrument's internal date.	page 76
:ERRor?	Returns the contents of the instrument's error queue.	page 76
:HELP:HEADers?	Returns a list of GPIB commands.	page 77
:PRESet	Sets all parameters to their default values.	page 77
:TIME/?	Sets or returns the instrument's internal time.	page 77
:VERSion?	Returns the instrument's SCPI version.	page 78
:SYSTem:COMMunicate:GPIB		
:[SELF]:ADDress/?	Sets or returns the GPIB address.	page 78
:TRIGger	Generates a hardware trigger.	page 172, page 179
:CONFIguration/?	Sets or returns trigger configuration.	page 177
:TRIGger:CONFIguration		
:EXTended/?	Sets or returns extended trigger configuration.	page 179
:FPEDal/?	Enables/disables the Input Trigger connector to be triggered using a Foot Pedal or returns whether the Input Trigger connector can be triggered using a Foot Pedal.	page 178
:TRIGger[n][CHANnel[m]]		
:INPut/?	Sets or returns the incoming trigger response .	page 173
:OFFset/?	Sets or returns the number of incoming triggers received before data logging begins	page 175
:INPut:REARm/?	Re-arms input trigger	page 174
:OUTPut/?	Sets or returns the outgoing trigger response.	page 176
:OUTPut:REARm/?	Re-arms output trigger	page 177

3

Instrument Setup and Status

This chapter gives descriptions of commands that you can use when setting up your instrument. The commands are split into the following separate subsystems:

- IEEE specific commands that were introduced in “*Common Commands*” on page 29.
- STATus subsystem commands that relate to the status model.
- SYSTem subsystem commands that control the serial interface and internal data.

IEEE-Common Commands	56
Status Reporting – The STATus Subsystem	64
Interface/Instrument Behaviour Settings – The SYSTem Subsystem	76

IEEE-Common Commands

“Common Commands” on page 29 gave a brief introduction to the IEEE-common commands which can be used with the instruments. This section gives fuller descriptions of each of these commands.

command:	*CLS
syntax:	*CLS
description:	<p>The CLear Status command *CLS clears the following:</p> <ul style="list-style-type: none"> • Error queue • Standard event status register (SESR) • Status byte register (STB) <p>After the *CLS command the instrument is left waiting for the next command. The instrument setting is unaltered by the command, although *OPC/*OPC? actions are cancelled.</p>
parameters:	none
response:	none
example:	*CLS

command:	*ESE																											
syntax:	*ESE<wsp><value> $0 \leq \text{value} \leq 255$																											
description:	<p>The standard Event Status Enable command (*ESE) sets bits in the Standard Event Status Enable Mask (SESEM) that enable the corresponding bits in the standard event status register (SESR).</p> <p>The register is cleared:</p> <ul style="list-style-type: none"> • at power-on, • by sending a value of zero. <p>The register is not changed by the *RST and *CLS commands.</p>																											
parameters:	<p>The bit value for the register (a 16-bit signed integer value):</p> <table border="1"> <thead> <tr> <th>Bit</th> <th>Mnemonic</th> <th>Decimal Value</th> </tr> </thead> <tbody> <tr> <td>7 (MSB)</td> <td>Power On</td> <td>128</td> </tr> <tr> <td>6</td> <td>Not Used</td> <td>0</td> </tr> <tr> <td>5</td> <td>Command Error</td> <td>32</td> </tr> <tr> <td>4</td> <td>Execution Error</td> <td>16</td> </tr> <tr> <td>3</td> <td>Device Dependent Error</td> <td>8</td> </tr> <tr> <td>2</td> <td>Query Error</td> <td>4</td> </tr> <tr> <td>1</td> <td>Not Used</td> <td>0</td> </tr> <tr> <td>0 (LSB)</td> <td>Operation Complete</td> <td>1</td> </tr> </tbody> </table>	Bit	Mnemonic	Decimal Value	7 (MSB)	Power On	128	6	Not Used	0	5	Command Error	32	4	Execution Error	16	3	Device Dependent Error	8	2	Query Error	4	1	Not Used	0	0 (LSB)	Operation Complete	1
Bit	Mnemonic	Decimal Value																										
7 (MSB)	Power On	128																										
6	Not Used	0																										
5	Command Error	32																										
4	Execution Error	16																										
3	Device Dependent Error	8																										
2	Query Error	4																										
1	Not Used	0																										
0 (LSB)	Operation Complete	1																										
response:	none																											
example:	*ESE 21																											

command:	*ESE?
syntax:	*ESE?
description:	The standard Event Status Enable query *ESE? returns the contents of the Standard Event Status Enable Mask (see *ESE for information on this register).
parameters:	none
response:	The bit value for the register (a <i>16-bit signed integer</i> value).
example:	*ESE? → 21<END>

command:	*ESR?																											
syntax:	*ESR?																											
description:	The standard Event Status Register query *ESR? returns the contents of the Standard Event Status Register. The register is cleared after being read.																											
parameters:	none																											
response:	The bit value for the register (a <i>16-bit signed integer</i> value):																											
	<table border="1"> <thead> <tr> <th>Bit</th> <th>Mnemonic</th> <th>Decimal Value</th> </tr> </thead> <tbody> <tr> <td>7 (MSB)</td> <td>Power On</td> <td>128</td> </tr> <tr> <td>6</td> <td>Not used</td> <td>0</td> </tr> <tr> <td>5</td> <td>Command Error</td> <td>32</td> </tr> <tr> <td>4</td> <td>Execution Error</td> <td>16</td> </tr> <tr> <td>3</td> <td>Device Dependent Error</td> <td>8</td> </tr> <tr> <td>2</td> <td>Query Error</td> <td>4</td> </tr> <tr> <td>1</td> <td>Not used</td> <td>0</td> </tr> <tr> <td>0 (LSB)</td> <td>Operation Complete</td> <td>1</td> </tr> </tbody> </table>	Bit	Mnemonic	Decimal Value	7 (MSB)	Power On	128	6	Not used	0	5	Command Error	32	4	Execution Error	16	3	Device Dependent Error	8	2	Query Error	4	1	Not used	0	0 (LSB)	Operation Complete	1
Bit	Mnemonic	Decimal Value																										
7 (MSB)	Power On	128																										
6	Not used	0																										
5	Command Error	32																										
4	Execution Error	16																										
3	Device Dependent Error	8																										
2	Query Error	4																										
1	Not used	0																										
0 (LSB)	Operation Complete	1																										
example:	*ESR? → 21<END>																											

command:	*IDN?								
syntax:	*IDN?								
description:	The IDeNtification query *IDN? gets the instrument identification over the interface.								
parameters:	none								
response:	The identification terminated by <END>: <i>For example.</i> <table style="margin-left: 40px; border: none;"> <tr> <td style="padding-right: 40px;">Agilent Technologies</td> <td>manufacturer</td> </tr> <tr> <td>mmmm</td> <td>instrument model number (for example 8164B)</td> </tr> <tr> <td>ssssssss</td> <td>serial number</td> </tr> <tr> <td>rrrrrrrr</td> <td>firmware revision level</td> </tr> </table>	Agilent Technologies	manufacturer	mmmm	instrument model number (for example 8164B)	ssssssss	serial number	rrrrrrrr	firmware revision level
Agilent Technologies	manufacturer								
mmmm	instrument model number (for example 8164B)								
ssssssss	serial number								
rrrrrrrr	firmware revision level								
example:	*IDN? → Agilent Technologies,mmmm,ssssssss,rrrrrrrr<END>								
NOTE	The Agilent 8163A, Agilent 8164A, and Agilent8166A will always return Agilent Technologies as the manufacturer. This will not be affected by the transition of these instruments to Agilent Technologies. This will allow programs that use this string to continue functioning. See “.:SLOT[n]:HEAD[n]:IDN?” on page 82 for information on module identity strings.								

command:	*OPC
syntax:	*OPC
description:	The instrument parses and executes all program message units in the input queue and sets the operation complete bit in the standard event status register (SESR). This command can be used to avoid filling the input queue before the previous commands have finished executing. Some module firmware includes commands that set a "StatNOPC" flag during execution to indicate that the module is busy. *OPC blocks the GPIB bus to all commands until every module hosted by the instrument is no longer busy. The following actions cancel the *OPC command (and put the instrument into Operation Complete, Command Idle State): <ul style="list-style-type: none"> • Power-on • the Device Clear Active State is asserted on the interface. • *CLS • *RST
parameters:	none
response:	none
example:	*OPC

command:	*OPC?
syntax:	*OPC?
description:	<p>The OPERATION Complete query *OPC? parses all program message units in the input queue, sets the operation complete bit in the Standard Event Status register, and places an ASCII '1' in the output queue, when the contents of the input queue have been processed.</p> <p>Some module firmware includes commands that set a "StatNOPC" flag during execution to indicate that the module is busy. If a module is executing a command which generates a "StatNOPC" flag, the GPIB bus is not blocked to a command to another module. A second command to a busy module is blocked until the module flag "StatOK" is set. Taking advantage of this feature, and using *OPC? in a loop to query until the instrument returns 1, can lead to useful gains in program execution efficiency.</p> <p>The following actions cancel the *OPC? query (and put the instrument into Operation Complete, Command Idle State):</p> <ul style="list-style-type: none"> • Power-on • the Device Clear Active State is asserted on the interface. • *CLS • *RST
parameters:	none
response:	<p>1<END> is returned if all modules are ready to execute a new operation.</p> <p>0<END> is returned if any module is busy.</p>
example:	*OPC? → 1<END>

command:	*OPT?
syntax:	*OPT?
description:	The OPTions query *OPT? returns the modules installed in your instrument.
parameters:	none
response:	<p>Returns the part number of all installed modules, separated by commas.</p> <p>Slots are listed starting with the lowest slot number, that is, slot 0 for the Agilent 8164A/B and Slot 1 for the Agilent 8163A/B and Agilent 8166A/B.</p> <p>If any slot is empty or not recognised, two spaces are inserted instead of the module's part number. See the example below, where slots 1 and 4 are empty.</p>
example:	*OPT? → 81682A , , 81533B, 81532A, <END>

command:	*RST
syntax:	*RST
description:	<p>The ReSeT command *RST sets the mainframe and all modules to the reset setting (standard setting) stored internally.</p> <p>Pending *OPC? actions are cancelled.</p> <p>The instrument is placed in the idle state awaiting a command. The *RST command clears the error queue.</p> <p>The *RST command is equivalent to the *CLS command AND the syst:preset command.</p> <p>The following are not changed:</p> <ul style="list-style-type: none"> • GPIB (interface) state • Instrument interface address • Output queue • Service request enable register (SRE) • Standard Event Status Enable Mask (SESEM)
parameters:	none
response:	none
example:	*RST

command:	*STB?																											
syntax:	*STB?																											
description:	The SStatus Byte query *STB? returns the contents of the Status Byte register.																											
parameters:	none																											
response:	<p>The bit value for the register (a <i>16-bit signed integer</i> value):</p> <table border="1"> <thead> <tr> <th>Bit</th> <th>Mnemonic</th> <th>Decimal Value</th> </tr> </thead> <tbody> <tr> <td>7 (MSB)</td> <td>Operation Status (OSB)</td> <td>128</td> </tr> <tr> <td>6</td> <td>Not used</td> <td>0</td> </tr> <tr> <td>5</td> <td>Event Status Bit (ESB)</td> <td>32</td> </tr> <tr> <td>4</td> <td>Message Available (MAV)</td> <td>16</td> </tr> <tr> <td>3</td> <td>Questionable Status (QSB)</td> <td>8</td> </tr> <tr> <td>2</td> <td>Not used</td> <td>0</td> </tr> <tr> <td>1</td> <td>Not used</td> <td>0</td> </tr> <tr> <td>0</td> <td>Not used</td> <td>0</td> </tr> </tbody> </table>	Bit	Mnemonic	Decimal Value	7 (MSB)	Operation Status (OSB)	128	6	Not used	0	5	Event Status Bit (ESB)	32	4	Message Available (MAV)	16	3	Questionable Status (QSB)	8	2	Not used	0	1	Not used	0	0	Not used	0
Bit	Mnemonic	Decimal Value																										
7 (MSB)	Operation Status (OSB)	128																										
6	Not used	0																										
5	Event Status Bit (ESB)	32																										
4	Message Available (MAV)	16																										
3	Questionable Status (QSB)	8																										
2	Not used	0																										
1	Not used	0																										
0	Not used	0																										
example:	*STB? → 128<END>																											

command:	*TST?																																																															
syntax:	*TST?																																																															
description:	The self-TeST query *TST? makes the instrument perform a self-test and place the results of the test in the output queue. If the self-test fails, the results are also put in the error queue. We recommend that you read self-test results from the error queue. No further commands are allowed while the test is running. After the self-test the instrument is returned to the setting that was active at the time the self-test query was processed. The self-test does not require operator interaction beyond sending the *TST? query.																																																															
parameters:	none																																																															
response:	The sum of the results for the individual tests (a <i>32-bit signed integer</i> value, where $0 \leq \text{value} \leq 4294967296$):																																																															
	<table border="1"> <thead> <tr> <th>Bits</th> <th>Mnemonic</th> <th>Decimal Value</th> </tr> </thead> <tbody> <tr> <td>31</td> <td>Selftest failed on Mainframe</td> <td>A negative value</td> </tr> <tr> <td>18 - 30</td> <td>Not used</td> <td>0</td> </tr> <tr> <td>17</td> <td>Selftest failed on Slot 17</td> <td>131072</td> </tr> <tr> <td>16</td> <td>Selftest failed on Slot 16</td> <td>65536</td> </tr> <tr> <td>15</td> <td>Selftest failed on Slot 15</td> <td>32768</td> </tr> <tr> <td>14</td> <td>Selftest failed on Slot 14</td> <td>16384</td> </tr> <tr> <td>13</td> <td>Selftest failed on Slot 13</td> <td>8192</td> </tr> <tr> <td>12</td> <td>Selftest failed on Slot 12</td> <td>4096</td> </tr> <tr> <td>11</td> <td>Selftest failed on Slot 11</td> <td>2048</td> </tr> <tr> <td>10</td> <td>Selftest failed on Slot 10</td> <td>1024</td> </tr> <tr> <td>9</td> <td>Selftest failed on Slot 9</td> <td>512</td> </tr> <tr> <td>8</td> <td>Selftest failed on Slot 8</td> <td>256</td> </tr> <tr> <td>7</td> <td>Selftest failed on Slot 7</td> <td>128</td> </tr> <tr> <td>6</td> <td>Selftest failed on Slot 6</td> <td>64</td> </tr> <tr> <td>5</td> <td>Selftest failed on Slot 5</td> <td>32</td> </tr> <tr> <td>4</td> <td>Selftest failed on Slot 4</td> <td>16</td> </tr> <tr> <td>3</td> <td>Selftest failed on Slot 3</td> <td>8</td> </tr> <tr> <td>2</td> <td>Selftest failed on Slot 2</td> <td>4</td> </tr> <tr> <td>1</td> <td>Selftest failed on Slot 1</td> <td>2</td> </tr> <tr> <td>0</td> <td>Selftest failed on Slot 0</td> <td>1</td> </tr> </tbody> </table> <p>If 16 is returned, the module in slot 4 has failed. If 18 is returned, the modules in slots 1 and 4 have failed. A value of zero indicates no errors.</p>	Bits	Mnemonic	Decimal Value	31	Selftest failed on Mainframe	A negative value	18 - 30	Not used	0	17	Selftest failed on Slot 17	131072	16	Selftest failed on Slot 16	65536	15	Selftest failed on Slot 15	32768	14	Selftest failed on Slot 14	16384	13	Selftest failed on Slot 13	8192	12	Selftest failed on Slot 12	4096	11	Selftest failed on Slot 11	2048	10	Selftest failed on Slot 10	1024	9	Selftest failed on Slot 9	512	8	Selftest failed on Slot 8	256	7	Selftest failed on Slot 7	128	6	Selftest failed on Slot 6	64	5	Selftest failed on Slot 5	32	4	Selftest failed on Slot 4	16	3	Selftest failed on Slot 3	8	2	Selftest failed on Slot 2	4	1	Selftest failed on Slot 1	2	0	Selftest failed on Slot 0	1
Bits	Mnemonic	Decimal Value																																																														
31	Selftest failed on Mainframe	A negative value																																																														
18 - 30	Not used	0																																																														
17	Selftest failed on Slot 17	131072																																																														
16	Selftest failed on Slot 16	65536																																																														
15	Selftest failed on Slot 15	32768																																																														
14	Selftest failed on Slot 14	16384																																																														
13	Selftest failed on Slot 13	8192																																																														
12	Selftest failed on Slot 12	4096																																																														
11	Selftest failed on Slot 11	2048																																																														
10	Selftest failed on Slot 10	1024																																																														
9	Selftest failed on Slot 9	512																																																														
8	Selftest failed on Slot 8	256																																																														
7	Selftest failed on Slot 7	128																																																														
6	Selftest failed on Slot 6	64																																																														
5	Selftest failed on Slot 5	32																																																														
4	Selftest failed on Slot 4	16																																																														
3	Selftest failed on Slot 3	8																																																														
2	Selftest failed on Slot 2	4																																																														
1	Selftest failed on Slot 1	2																																																														
0	Selftest failed on Slot 0	1																																																														
example:	*TST? → 0<END>																																																															

command:	*WAI
syntax:	*WAI
description:	The WAI command prevents the instrument from executing any further commands until the current command has finished executing. Some module firmware includes commands that set a "StatNOPC" flag during execution to indicate that the module is busy. *WAI blocks the GPIB bus to all commands until every module hosted by the instrument is no longer busy. All pending operations, are completed during the wait period.
parameters:	none
response:	none
example:	*WAI

Status Reporting – The STATUS Subsystem

The Status subsystem allows you to return and set details from the Status Model. For more details, see “*The Status Model*” on page 33.

command:	:STATus:OPERation[:EVENT][[:LEVel0]?				
syntax:	:STATus:OPERation[:EVENT][[:LEVel0]?				
description:	Returns the Operational Status Event Summary Register (OSESr).				
parameters:	none				
response:	The sum of the results for the slots (a 16-bit signed integer value, where $0 \leq \text{value} \leq 32767$):				
	Bits	Mnemonics		Decimal Value	
		Agilent 8163A/B	Agilent 8164A/B	Agilent 8166A/B	
	15	Not used	Not used	Not used	0
	14	Not used	Not used	Slot 14 Summary	16384
	13	Not used	Not used	Slot 13 Summary	8192
	12	Not used	Not used	Slot 12 Summary	4096
	11	Not used	Not used	Slot 11 Summary	2048
	10	Not used	Not used	Slot 10 Summary	1024
	9	Not used	Not used	Slot 9 Summary	512
	8	Not used	Not used	Slot 8 Summary	256
	7	Not used	Not used	Slot 7 Summary	128
	6	Not used	Not used	Slot 6 Summary	64
	5	Not used	Not used	Slot 5 Summary	32
	4	Not used	Slot 4 Summary	Slot 4 Summary	16
	3	Not used	Slot 3 Summary	Slot 3 Summary	8
	2	Slot 2 Summary	Slot 2 Summary	Slot 2 Summary	4
	1	Slot 1 Summary	Slot 1 Summary	Slot 1 Summary	2
	0	Not used	Slot 0 Summary	Level 1 Summary	1
example:	stat:oper? → +0<END>				

command:	:STATus:OPERation:CONDition[:LEVel0]?				
syntax:	:STATus:OPERation:CONDition[:LEVel0]?				
description:	Reads the Operational Status Condition Summary Register.				
parameters:	none				
response:	The sum of the results for the individual slots (a <i>16-bit signed integer</i> value, where $0 \leq \text{value} \leq 32767$):				
	Bits	Mnemonics			Decimal Value
		Agilent 8163A/B	Agilent 8164A/B	Agilent 8166A/B	
	15	Not used	Not used	Not used	0
	14	Not used	Not used	Slot 14 Summary	16384
	13	Not used	Not used	Slot 13 Summary	8192
	12	Not used	Not used	Slot 12 Summary	4096
	11	Not used	Not used	Slot 11 Summary	2048
	10	Not used	Not used	Slot 10 Summary	1024
	9	Not used	Not used	Slot 9 Summary	512
	8	Not used	Not used	Slot 8 Summary	256
	7	Not used	Not used	Slot 7 Summary	128
	6	Not used	Not used	Slot 6 Summary	64
	5	Not used	Not used	Slot 5 Summary	32
	4	Not used	Slot 4 Summary	Slot 4 Summary	16
	3	Not used	Slot 3 Summary	Slot 3 Summary	8
	2	Slot 2 Summary	Slot 2 Summary	Slot 2 Summary	4
	1	Slot 1 Summary	Slot 1 Summary	Slot 1 Summary	2
	0	Not used	Slot 0 Summary	Level 1 Summary	1
example:	stat:oper:cond? → +0<END>				

command:	:STATus:OPERation:ENABLE[:LEVel0]
syntax:	:STATus:OPERation:ENABLE[:LEVel0]<wsp><value>
description:	Sets the bits in the Operational Status Enable Summary Mask (OSESMS) that enable the contents of the OSESR to affect the Status Byte (STB). Setting a bit in this register to 1 enables the corresponding bit in the OSESR to affect bit 7 of the Status Byte.
parameters:	The bit value for the OSESMS as a <i>16-bit signed integer</i> value (0 .. +32767) The default value is 0.
response:	none
example:	stat:oper:enab 128

command:	:STATus:OPERation:ENABLE[:LEVel0]?
syntax:	:STATus:OPERation:ENABLE[:LEVel0]?
description:	Returns the OSESMS for the OSESR
parameters:	none
response:	The bit value for the operation enable mask as a <i>16-bit signed integer</i> value (0 .. +32767)
example:	stat:oper:enab? → +128<END>

command:	:STATus:OPERation[:EVENT]:LEVel1?																					
syntax:	:STATus:OPERation[:EVENT]:LEVel1?																					
description:	Returns the Operational Status Event Summary Register (OSESER) for slots 15 to 17 of the Agilent 8166A/B Lightwave Multichannel System.																					
parameters:	none																					
response:	The sum of the results for the slots (a <i>16-bit signed integer</i> value, where $0 \leq \text{value} \leq 32767$): <table border="1"> <thead> <tr> <th>Bits</th> <th>Mnemonics</th> <th>Decimal Value</th> </tr> </thead> <tbody> <tr> <td colspan="3" style="text-align: center;">Agilent 8166A/B</td> </tr> <tr> <td>15-4</td> <td>Not used</td> <td>0</td> </tr> <tr> <td>3</td> <td>Slot 17 Summary</td> <td>8</td> </tr> <tr> <td>2</td> <td>Slot 16 Summary</td> <td>4</td> </tr> <tr> <td>1</td> <td>Slot 15 Summary</td> <td>2</td> </tr> <tr> <td>0</td> <td>Not used</td> <td>0</td> </tr> </tbody> </table>	Bits	Mnemonics	Decimal Value	Agilent 8166A/B			15-4	Not used	0	3	Slot 17 Summary	8	2	Slot 16 Summary	4	1	Slot 15 Summary	2	0	Not used	0
Bits	Mnemonics	Decimal Value																				
Agilent 8166A/B																						
15-4	Not used	0																				
3	Slot 17 Summary	8																				
2	Slot 16 Summary	4																				
1	Slot 15 Summary	2																				
0	Not used	0																				
example:	stat:oper:level1? → +0<END>																					

command:	:STATus:OPERation:CONDition:LEVel1?																					
syntax:	:STATus:OPERation:CONDition:LEVel1?																					
description:	Returns the Operational Status Condition Summary Register for slots 15 to 17 of the Agilent 8166B Lightwave Multichannel System.																					
parameters:	none																					
response:	The sum of the results for slots 15 to 17 (a <i>16-bit signed integer</i> value, where $0 \leq \text{value} \leq 32767$):																					
	<table border="1"> <thead> <tr> <th>Bits</th> <th>Mnemonics</th> <th>Decimal Value</th> </tr> </thead> <tbody> <tr> <td colspan="3" style="text-align:center">Agilent 8166A/B</td> </tr> <tr> <td>15-4</td> <td>Not used</td> <td>0</td> </tr> <tr> <td>3</td> <td>Slot 17 Summary</td> <td>8</td> </tr> <tr> <td>2</td> <td>Slot 16 Summary</td> <td>4</td> </tr> <tr> <td>1</td> <td>Slot 15 Summary</td> <td>2</td> </tr> <tr> <td>0</td> <td>Not used</td> <td>0</td> </tr> </tbody> </table>	Bits	Mnemonics	Decimal Value	Agilent 8166A/B			15-4	Not used	0	3	Slot 17 Summary	8	2	Slot 16 Summary	4	1	Slot 15 Summary	2	0	Not used	0
Bits	Mnemonics	Decimal Value																				
Agilent 8166A/B																						
15-4	Not used	0																				
3	Slot 17 Summary	8																				
2	Slot 16 Summary	4																				
1	Slot 15 Summary	2																				
0	Not used	0																				
example:	stat:oper:cond:level1? → +0<END>																					

command:	:STATus:OPERation:ENABLE:LEVel1
syntax:	:STATus:OPERation:ENABLE:LEVel1<wsp><value>
description:	<p>Sets the bits in the Operational Status Enable Summary Mask (OSES M) that enable the contents of the OSES R for slots 15 - 17 of the Agilent 8166A/B Lightwave Measurement System to affect the Status Byte (STB).</p> <p>Setting a bit in this register to 1 enables the corresponding bit in the OSES R for slots 15 - 17 of the Agilent 8166A/B Lightwave Measurement System to affect bit 7 of the Status Byte.</p>
parameters:	<p>The bit value for the OSES M as a <i>16-bit signed integer</i> value (0 .. +32767)</p> <p>The default value is 0.</p>
response:	none
example:	stat:oper:enab:level1 128

command:	:STATus:OPERation:ENABLE:LEVel1?
syntax:	:STATus:OPERation:ENABLE:LEVel1?
description:	Returns the OSES M for the OSES R for slots 15 - 17 of the Agilent 8166A/B Lightwave Measurement System
parameters:	none
response:	The bit value for the operation enable mask as a <i>16-bit signed integer</i> value (0 .. +32767)
example:	stat:oper:enab:level1? → +128<END>

command:	:STATus n :OPERation[:EVENT]?		
syntax:	:STATus n :OPERation[:EVENT]?		
description:	Returns the Operational Slot Status Event Register (OSSER) of slot n .		
parameters:	none		
response:	The results for the individual slot events (a 16-bit signed integer value, where $0 \leq \text{value} \leq 32767$):		
	Bit	Mnemonic	Decimal Value
	8-15	Not used	0
	7	Slot n : offset (λ) type bit 2	128
	6	Slot n : offset (λ) type bit 1	64
	5	Slot n : offset (λ) has been enabled	32
	4	Slot n : shutter has been opened	16
	3	Slot n : Zeroing ongoing	8
	2	Not used	0
	1	Slot n : Coherence Control has been switched on	2
	0	Slot n : Laser has been switched on	1
example:	stat1:oper? → +0<END>		

command:	:STATus n :OPERation:CONDition?		
syntax:	:STATus n :OPERation:CONDition?		
description:	Returns the Operational Slot Status Condition Register of slot n .		
parameters:	none		
response:	The results for the individual slot events (a 16-bit signed integer value, where $0 \leq \text{value} \leq 32767$):		
	Bit	Mnemonic	Decimal Value
	8-15	Not used	0
	7	Slot n : offset (λ) type bit 2	128
	6	Slot n : offset (λ) type bit 1	64
	5	Slot n : offset (λ) enabled	32
	4	Slot n : shutter open	16
	3	Slot n : Zeroing ongoing	8
	2	Not used	0
	1	Slot n : Coherence Control is switched on	2
	0	Slot n : Laser is switched on	1
example:	stat1:oper:cond? → +0<END>		
	NOTE: Only attenuator bits 5 to 7 are used to show whether the offset feature is used and which algorithm is used to calculate the wavelength dependent offset.		
	Bit 5 states if the feature is enabled or disabled. Bits 6 and 7 are decoded as shown below to say whether the attenuator uses saved, interpolated, or extrapolated values.		

Type	Bit 5	Bit 6	Bit 7	Decimal Value
none	0	0	0	0
exact value	1	0	0	32
extrapolate below	1	1	0	96
extrapolate above	1	0	1	160
interpolated	1	1	1	224

command:	:STATUSn:OPERation:ENABLE
syntax:	:STATUSn:OPERation:ENABLE<wsp><value>
description:	Sets the bits in the Operation Slot Status Enable Mask (OSSEM) for slot <i>n</i> that enable the contents of the Operation Slot Status Event Register (OSSER) for slot <i>n</i> to affect the OSESER. Setting a bit in this register to 1 enables the corresponding bit in the OSSER for slot <i>n</i> to affect bit <i>n</i> of the OSESER.
parameters:	The bit value for the OSSEM as a <i>16-bit signed integer</i> value (0 .. +32767)
response:	none
example:	stat:oper:enab 128

command:	:STATUSn:OPERation:ENABLE?
syntax:	:STATUSn:OPERation:ENABLE?
description:	Returns the OSSEM of slot <i>n</i>
parameters:	none
response:	The bit value for the OSSEM as a <i>16-bit signed integer</i> value (0 .. +32767)
example:	stat:oper:enab? → +128<END>

command:	:STATUS:PRESet
syntax:	:STATUS:PRESet
description:	Presets all bits in all the enable masks for both the OPERation and QUEStionable status systems to 0, that is, OSSEM, QSSEM, OSESM, and QSESM.
parameters:	none
response:	none
example:	stat:pres

command:	:STATus:QUEStionable[:EVENT][:LEVel0]?				
syntax:	:STATus:QUEStionable[:EVENT][:LEVel0]?				
description:	Returns the Questionable Status Event Summary Register (QSESR).				
parameters:	none				
response:	The sum of the results for the QSESR as a <i>16-bit signed integer</i> value (0 .. +32767)				
	Bits	Mnemonics			Decimal Value
		Agilent 8163A/B	Agilent 8164A/B	Agilent 8166A/B	
	15	Not used	Not used	Not used	0
	14	Not used	Not used	Slot 14 Summary	16384
	13	Not used	Not used	Slot 13 Summary	8192
	12	Not used	Not used	Slot 12 Summary	4096
	11	Not used	Not used	Slot 11 Summary	2048
	10	Not used	Not used	Slot 10 Summary	1024
	9	Not used	Not used	Slot 9 Summary	512
	8	Not used	Not used	Slot 8 Summary	256
	7	Not used	Not used	Slot 7 Summary	128
	6	Not used	Not used	Slot 6 Summary	64
	5	Not used	Not used	Slot 5 Summary	32
	4	Not used	Slot 4 Summary	Slot 4 Summary	16
	3	Not used	Slot 3 Summary	Slot 3 Summary	8
	2	Slot 2 Summary	Slot 2 Summary	Slot 2 Summary	4
	1	Slot 1 Summary	Slot 1 Summary	Slot 1 Summary	2
	0	Not used	Slot 0 Summary	Level 1 Summary	1
example:	stat:ques? → +0<END>				

command:	:STATus:QUEStionable:CONDition[:LEVel0]?				
syntax:	:STATus:QUEStionable:CONDition[:LEVel0]?				
description:	Returns the Questionable Status Condition Summary Register.				
parameters:	none				
response:	The sum of the results for the Questionable Status Condition Summary Register as a <i>16-bit signed integer</i> value (0 .. +32767)				
	Bits	Mnemonics			Decimal Value
		Agilent 8163A/B	Agilent 8164A/B	Agilent 8166A/B	
	15	Not used	Not used	Not used	0
	14	Not used	Not used	Slot 14 Summary	16384
	13	Not used	Not used	Slot 13 Summary	8192
	12	Not used	Not used	Slot 12 Summary	4096
	11	Not used	Not used	Slot 11 Summary	2048
	10	Not used	Not used	Slot 10 Summary	1024
	9	Not used	Not used	Slot 9 Summary	512
	8	Not used	Not used	Slot 8 Summary	256
	7	Not used	Not used	Slot 7 Summary	128
	6	Not used	Not used	Slot 6 Summary	64
	5	Not used	Not used	Slot 5 Summary	32
	4	Not used	Slot 4 Summary	Slot 4 Summary	16
	3	Not used	Slot 3 Summary	Slot 3 Summary	8
	2	Slot 2 Summary	Slot 2 Summary	Slot 2 Summary	4
	1	Slot 1 Summary	Slot 1 Summary	Slot 1 Summary	2
	0	Not used	Slot 0 Summary	Level 1 Summary	1
example:	stat:ques:cond? → +0<END>				

command:	:STATus:QUEStionable:ENABle[:LEVel0]
syntax:	:STATus:QUEStionable:ENABle[:LEVel0]<wsp><value>
description:	Sets the bits in the Questionable Status Enable Summary Mask (QSESM) that enable the contents of the QSESR to affect the Status Byte (STB). Setting a bit in this register to 1 enables the corresponding bit in the QSESR to affect bit 3 of the Status Byte.
parameters:	The bit value for the questionable enable mask as a <i>16-bit signed integer</i> value (0 .. +32767) The default value is 0.
response:	none
example:	stat:ques:enab 128

command:	:STATus:QUEStionable:ENABle[:LEVel0]?
syntax:	:STATus:QUEStionable:ENABle[:LEVel0]?
description:	Returns the QSESM for the event register
parameters:	none
response:	The bit value for the QSEM as a <i>16-bit signed integer</i> value (0 .. +32767)
example:	stat:ques:enab? → +128<END>

command:	:STATus:QUEStionable[:EVENT]:LEVel1?																					
syntax:	:STATus:QUEStionable[:EVENT]:LEVel1?																					
description:	Returns the Questionable Status Event Summary Register (QSESR) for slots 15 to 17 of the Agilent 8166A/B Lightwave Multichannel System.																					
parameters:	none																					
response:	The sum of the results for the slots (a <i>16-bit signed integer</i> value, where $0 \leq \text{value} \leq 32767$):																					
	<table border="1"> <thead> <tr> <th>Bits</th> <th>Mnemonics</th> <th>Decimal Value</th> </tr> </thead> <tbody> <tr> <td colspan="3" style="text-align: center;">Agilent 8166A/B</td> </tr> <tr> <td>15-4</td> <td>Not used</td> <td>0</td> </tr> <tr> <td>3</td> <td>Slot 17 Summary</td> <td>8</td> </tr> <tr> <td>2</td> <td>Slot 16 Summary</td> <td>4</td> </tr> <tr> <td>1</td> <td>Slot 15 Summary</td> <td>2</td> </tr> <tr> <td>0</td> <td>Not used</td> <td>0</td> </tr> </tbody> </table>	Bits	Mnemonics	Decimal Value	Agilent 8166A/B			15-4	Not used	0	3	Slot 17 Summary	8	2	Slot 16 Summary	4	1	Slot 15 Summary	2	0	Not used	0
Bits	Mnemonics	Decimal Value																				
Agilent 8166A/B																						
15-4	Not used	0																				
3	Slot 17 Summary	8																				
2	Slot 16 Summary	4																				
1	Slot 15 Summary	2																				
0	Not used	0																				
example:	stat:ques:level1? → +0<END>																					

command:	:STATUS:QUESTIONABLE:CONDITION:LEVEL1?																					
syntax:	:STATUS:QUESTIONABLE:CONDITION:LEVEL1?																					
description:	Returns the Questionable Status Condition Summary Register for slots 15 to 17 of the Agilent 8166A/B Lightwave Multichannel System.																					
parameters:	none																					
response:	The sum of the results for the slots (a <i>16-bit signed integer</i> value, where $0 \leq \text{value} \leq 32767$):																					
	<table border="1"> <thead> <tr> <th>Bits</th> <th>Mnemonics</th> <th>Decimal Value</th> </tr> </thead> <tbody> <tr> <td colspan="3" style="text-align: center;">Agilent 8166A/B</td> </tr> <tr> <td>15-4</td> <td>Not used</td> <td>0</td> </tr> <tr> <td>3</td> <td>Slot 17 Summary</td> <td>8</td> </tr> <tr> <td>2</td> <td>Slot 16 Summary</td> <td>4</td> </tr> <tr> <td>1</td> <td>Slot 15 Summary</td> <td>2</td> </tr> <tr> <td>0</td> <td>Not used</td> <td>0</td> </tr> </tbody> </table>	Bits	Mnemonics	Decimal Value	Agilent 8166A/B			15-4	Not used	0	3	Slot 17 Summary	8	2	Slot 16 Summary	4	1	Slot 15 Summary	2	0	Not used	0
Bits	Mnemonics	Decimal Value																				
Agilent 8166A/B																						
15-4	Not used	0																				
3	Slot 17 Summary	8																				
2	Slot 16 Summary	4																				
1	Slot 15 Summary	2																				
0	Not used	0																				
example:	stat:ques:cond:level1? → +0<END>																					

command:	:STATUS:QUESTIONABLE:ENABLE:LEVEL1
syntax:	:STATUS:QUESTIONABLE:ENABLE:LEVEL1<wsp><value>
description:	<p>Sets the bits in the Questionable Status Enable Summary Mask (QSESM) that enable the contents of the QSESR for slots 15 - 17 of the Agilent 8166A/B Lightwave Measurement System to affect the Status Byte (STB).</p> <p>Setting a bit in this register to 1 enables the corresponding bit in the QSESR for slots 15 - 17 of the Agilent 8166A/B Lightwave Measurement System to affect bit 7 of the Status Byte.</p>
parameters:	<p>The bit value for the QSESM as a <i>16-bit signed integer</i> value (0 .. +32767)</p> <p>The default value is 0.</p>
response:	none
example:	stat:oper:enab:level1 128

command:	:STATUS:QUESTIONABLE:ENABLE:LEVEL1?
syntax:	:STATUS:QUESTIONABLE:ENABLE:LEVEL1?
description:	Returns the QSESM for the QSESR for slots 15 - 17 of the Agilent 8166A/B Lightwave Measurement System
parameters:	none
response:	The bit value for the QSESM as a <i>16-bit signed integer</i> value (0 .. +32767)
example:	stat:oper:enab:level1? → +128<END>

command:	:STATUSn:QUESTIONABLE[:EVENT]?		
syntax:	:STATUSn:QUESTIONABLE[:EVENT]?		
description:	Returns the questionable status of slot <i>n</i> - the Questionable Slot Status Event Register (QSS-ER).		
parameters:	none		
response:	The results for the individual slot events (a <i>16-bit signed integer</i> value, where $0 \leq \text{value} \leq 32767$):		
	Bit	Mnemonic	Decimal Value
	11-15	Not Used	0
	10	Slot <i>n</i> : Lambda zeroing has been recommended	1024
	9	Slot <i>n</i> : Beam Path Protection on (shutter off)	512
	8	Slot <i>n</i> : Coherence control is uncalibrated	256
	7	Slot <i>n</i> : Duty cycle has been out of range	128
	6	Slot <i>n</i> : ARA has been recommended	64
	5	Slot <i>n</i> : Module has been out of specification	32
	4	Slot <i>n</i> : Module has settled unsuccessfully	16
	3	Slot <i>n</i> : Laser protection has been on	8
	2	Slot <i>n</i> : Temperature has been out of range	4
	1	Slot <i>n</i> : A Zeroing operation has failed	2
	0	Slot <i>n</i> : Excessive Value has occurred	1
	Every <i>n</i> th bit is the summary of slot <i>n</i> .		
example:	stat1:oper? → +0<END>		

command:	:STATUSn:QUESTIONABLE:CONDITION?		
syntax:	:STATUSn:QUESTIONABLE:CONDITION?		
description:	Returns the Questionable Slot Status Condition Register for slot <i>n</i> .		
parameters:	none		
response:	The results for the individual slot events (a <i>16-bit signed integer</i> value, where $0 \leq \text{value} \leq 32767$):		
	Bit	Mnemonic	Decimal Value
	11 - 15	Not Used	
	10	Slot <i>n</i> : Lambda zeroing is recommended	1024
	9	Slot <i>n</i> : Beam Path Protection on (shutter off)	512
	8	Slot <i>n</i> : Coherence control is uncalibrated	256
	7	Slot <i>n</i> : Duty cycle is out of range	128
	6	Slot <i>n</i> : ARA recommended	64
	5	Slot <i>n</i> : Module is out of specification	32
	4	Slot <i>n</i> : Module has not settled	16
	3	Slot <i>n</i> : Laser protection on	8
	2	Slot <i>n</i> : Temperature out of range	4
	1	Slot <i>n</i> : Zeroing failed	2
	0	Slot <i>n</i> : Excessive Value	1
	Every <i>n</i> th bit is the summary of slot <i>n</i> .		
example:	stat1:ques:cond? → +0<END>		

command:	:STATUSn:QUESTIONable:ENABLE
syntax:	:STATUS n :QUESTIONable:ENABLE<wsp><value>
description:	<p>Sets the bits in the Questionable Slot Status Enable Mask (QSSEM) for slot n that enable the contents of the Questionable Slot Status Register (QSSR) for slot n to affect the QSESR.</p> <p>Setting a bit in this register to 1 enables the corresponding bit in the QSSER for slot n to affect bit n of the QSESR.</p>
parameters:	The bit value for the QSSEM as a <i>16-bit signed integer</i> value (0 .. +32767)
response:	none
example:	stat:ques:enab 128

command:	:STATUSn:QUESTIONable:ENABLE?
syntax:	:STATUS n :QUESTIONable:ENABLE?
description:	Returns the QSSEM for slot n
parameters:	none
response:	The bit value for the QSSEM as a <i>16-bit signed integer</i> value (0 .. +32767)
example:	stat:ques:enab? → +128<END>

Interface/Instrument Behaviour Settings – The SYSTem Subsystem

The SYSTem subsystem lets you control the instrument's serial interface. You can also control some internal data (like date, time, and so on).

command:	:SYSTem:DATE
syntax:	:SYSTem:DATE<wsp><year>,<month>,<day>
description:	Sets the instrument's internal date.
parameters:	<ul style="list-style-type: none"> • the first value is the year (four digits), • the second value is the month, and • the third value is the day.
response:	none
example:	syst:date 1999, 1, 12

command:	:SYSTem:DATE?
syntax:	:SYSTem:DATE?
description:	Returns the instrument's internal date.
parameters:	none
response:	The date in the format year, month, day (<i>16-bit signed integer values</i>)
example:	syst:date? → +1999,+1,+12<END>

command:	:SYSTem:ERRor?
syntax:	:SYSTem:ERRor?
description:	<p>Returns the next error from the error queue (see <i>"The Error Queue" on page 22</i>).</p> <p>Each error has the error code and a <i>short</i> description of the error, separated by a comma, for example 0, "No error".</p> <p>Error codes are numbers in the range -32768 and +32767.</p> <p>Negative error numbers are defined by the SCPI standard. Positive error numbers are device dependent.</p>
parameters:	none
response:	The number of the latest error, and its meaning.
example:	syst:err? → -113,"Undefined header"<END>

command:	:SYSTem:HELP:HEADers?
syntax:	:SYSTem:HELP:HEADers?
description:	Returns a list of GPIB commands.
parameters:	none
response:	Returns a list of GPIB commands
example:	syst:help:head? → <i>Returns a list of all GPIB commands</i>

command:	:SYSTem:PRESet
syntax:	:SYSTem:PRESet
description:	<p>Sets the mainframe and all installed modules to their standard settings. This command has the same function as the Preset hardkey.</p> <p>The following are not affected by this command:</p> <ul style="list-style-type: none"> • the GPIB (interface) state, • the backlight and contrast of the display, • the interface address, • the output and error queues, • the Service Request Enable register (SRE), • the Status Byte (STB), • the Standard Event Status Enable Mask (SESEM), and • the Standard Event Status Register (SESR).
parameters:	none
response:	none
example:	SYST:PRES

command:	:SYSTem:TIME
syntax:	:SYSTem:TIME<wsp><hour>,<minute>,<second>
description:	Sets the instrument's internal time.
parameters:	<ul style="list-style-type: none"> • the first value is the hour (0 .. 23), • the second value is the minute, and • the third value is the seconds.
response:	none
example:	syst:time 20,15,30

command:	:SYSTem:TIME?
syntax:	:SYSTem:TIME?
description:	Returns the instrument's internal time.
parameters:	none
response:	The time in the format hour, minute, second. Hours are counted 0..23 (<i>16-bit signed integer values</i>).
example:	syst:time? → +20,+15,+30<END>

command:	:SYSTem:VERSion?
syntax:	:SYSTem:VERSion?
description:	Returns the SCPI revision to which the instrument complies.
parameters:	none
response:	The revision year and number.
example:	syst:vers? → 1995.0<END>

command:	:SYSTem:COMMunicate:GPIB[:SELF]:ADDRess
syntax:	:SYSTem:COMMunicate:GPIB[:SELF]:ADDRess<wsp><GPIB Address>
description:	Sets the GPIB address.
parameters:	The GPIB Address Values allowed 0-30 21 is often reserved by the GPIB Controller.
response:	none
example:	SYST:COMM:GPIB:ADDR 20

command:	:SYSTem:COMMunicate:GPIB[:SELF]:ADDRess?
syntax:	:SYSTem:COMMunicate:GPIB[:SELF]:ADDRess?
description:	Returns the GPIB address.
parameters:	none
response:	The GPIB Address
example:	SYST:COMM:GPIB:ADDR? → +20<END>

4

Measurement Operations & Settings

Root Layer Command	80
Measurement Functions – The SENSE subsystem	85
Agilent 81635A and Agilent 81619A - Master and Slave Channels	85
Signal Generation – The SOURCE subsystem	113
Signal Conditioning	148
The INPUT and OUTPUT commands	148
The table of wavelength-dependent offsets	159
Compatibility of the 81560A/1A/6A/7A modular attenuator family to the 8156A attenuator	165
Signal Routing	169
Triggering - The TRIGGER subsystem	171
Extended Trigger Configuration	179

This chapter gives descriptions of commands that you can use when you are setting up or performing measurements. The commands are split up into the following subsystems:

- Root layer commands that take power measurements, configures triggering, and return information about the mainframe and its slots
- SENSE subsystem commands that control Power Sensors, Optical Head Interface Modules, and Return Loss Modules.
- SOURCE subsystem commands that control Laser Source modules, DFB source modules, Tunable Laser modules, and Return Loss Modules with internal laser sources.
- Signal Conditioning commands that control Attenuator modules.
- TRIGGER subsystem commands that control triggering.

Root Layer Command

command:	:LOCK
syntax:	:LOCK<wsp><boolean>, <value>
description:	Switches the lock off and on. High power lasers cannot be switched on, if you switch the lock on. High power lasers are switched off immediately when you switch the lock on.
parameters:	A boolean value: 0 or OFF: switch lock off 1 or ON: switch lock on <value> is the four-figure lock password.
response:	none
example:	lock 1,1234 - 1234 is the default password

command:	:LOCK?
syntax:	:LOCK?
description:	Queries the current state of the lock.
parameters:	none
response:	A <i>boolean</i> value: 0: lock is switched off 1: lock is switched on
example:	lock? → 1<END>

The commands in the Slot subsystem allow you to query the following:

- a particular slot, for example, using slot1:empt?,
- or, an Optical Head attached to an Optical Head Interface Module, for example, an Optical Head Interface Module in slot1 with an Optical Head attached to channel 2, using slot1:head2:empt?.

command:	:SLOT[n]:EMPTy?	
syntax:	:SLOT[n]:EMPTy?	
description:	Queries whether the module slot is empty.	
parameters:	none	
response:	A <i>boolean</i> value:	0: there is a module in the slot 1: the module slot is empty
examples:	slot1:empt? → 0<END>	There is a module in slot1
affects:	Independent of module type	

command:	:SLOT[n]:IDN?	
syntax:	:SLOT[n]:IDN?	
description:	Returns information about the module.	
parameters:	none	
response:	HEWLETT-PACKARD:	manufacturer
	<i>mmmm</i> :	instrument model number (for example 81533B)
	<i>sssssss</i> :	serial number
	<i>rrrrrrrr</i> :	date of firmware revision
example:	slot1:idn? → HEWLETT-PACKARD, 81533B,3411G06054,07-Aug-98<END>	
NOTE	<ul style="list-style-type: none"> • The Agilent 81640A/80A/82A/89A Tunable Laser modules will always return Agilent Technologies as the manufacturer. • All other Agilent 8163A Series modules return Agilent Technologies as the manufacturer. • The HP 8153A Series modules will always return Agilent Technologies as the manufacturer. 	
	See “*IDN?” on page 59 for information on mainframe identity strings.	
affects:	Independent of module type	

command:	:SLOT[n]:OPTions?	
syntax:	:SLOT[n]:OPTions?	
description:	Returns information about a module’s options.	
parameters:	none	
response:	A string.	
example:	slot1:opt? → NO CONNECTOR OPTION, NO INSTRUMENT OPTIONS<END>	
affects:	Independent of module type	

command:	:SLOT[n]:TST?
syntax:	:SLOT[n]:TST?
description:	Returns the latest selftest results for a module.
NOTE	This command does not perform a selftest. Use selfTeST command, *TST? on page 59, to perform a selftest.
parameters:	none
response:	Returns an error code and a short description of the error.
example:	slot:tst? → +0,"self test OK"<END>
affects:	Independent of module type

command:	:SLOT[n]:HEAD[n]:EMPTY?				
syntax:	:SLOT[n]:HEAD[n]:EMPTY?				
description:	Queries whether an optical head is connected.				
parameters:	none				
response:	A <i>boolean</i> value: <table style="margin-left: 20px;"> <tr> <td>0:</td> <td>there is a module in the slot</td> </tr> <tr> <td>1:</td> <td>the module slot is empty</td> </tr> </table>	0:	there is a module in the slot	1:	the module slot is empty
0:	there is a module in the slot				
1:	the module slot is empty				
examples:	slot1:head:empt? → 0<END> <table style="margin-left: 20px;"> <tr> <td>An optical head is connected to the optical head interface module in slot 1</td> </tr> </table>	An optical head is connected to the optical head interface module in slot 1			
An optical head is connected to the optical head interface module in slot 1					
NOTE	<ul style="list-style-type: none"> The HP 8153A Series Optical Heads will always return Agilent Technologies as the manufacturer. All other Agilent 8163A Series Optical Heads return Agilent Technologies as the manufacturer. <p>See <i>"*IDN?"</i> on page 59 for information on mainframe identity strings.</p>				
affects:	Optical heads				

command:	:SLOT[n]:HEAD[n]:IDN?								
syntax:	:SLOT[n]:HEAD[n]:IDN?								
description:	Returns information about the optical head.								
parameters:	none								
response:	<table style="margin-left: 20px;"> <tr> <td>HEWLETT-PACKARD:</td> <td>manufacturer</td> </tr> <tr> <td><i>mmmm</i>:</td> <td>instrument model number (for example 81520A)</td> </tr> <tr> <td><i>sssssss</i>:</td> <td>serial number</td> </tr> <tr> <td><i>rrrrrrrr</i>:</td> <td>date of firmware revision</td> </tr> </table>	HEWLETT-PACKARD:	manufacturer	<i>mmmm</i> :	instrument model number (for example 81520A)	<i>sssssss</i> :	serial number	<i>rrrrrrrr</i> :	date of firmware revision
HEWLETT-PACKARD:	manufacturer								
<i>mmmm</i> :	instrument model number (for example 81520A)								
<i>sssssss</i> :	serial number								
<i>rrrrrrrr</i> :	date of firmware revision								
example:	slot1:head:idn? → HEWLETT-PACKARD, 81520A,3411G06054,07-Aug-98<END>								
affects:	Optical heads								

command:	:SLOT[<i>n</i>]:HEAD[<i>m</i>]:OPTions?
syntax:	:SLOT[<i>n</i>]:HEAD[<i>m</i>]:OPTions?
description:	Returns information about an optical head's options.
parameters:	none
response:	A string.
example:	slot1:head:opt? → NO CONNECTOR OPTION, NO INSTRUMENT OPTIONS<END>
affects:	Optical heads

command:	:SLOT[<i>n</i>]:HEAD[<i>m</i>]:TST?
syntax:	:SLOT[<i>n</i>]:HEAD[<i>m</i>]:TST?
description:	Returns the latest selftest results for an optical head.
NOTE	This command does not perform a selftest. Use selfTeST command, " <i>*TST?</i> " on page 62, to perform a selftest.
parameters:	none
response:	Returns an error code and a short description of the error.
example:	slot:head:tst? → +0,"self test OK"<END>
affects:	Optical heads

command:	:SLOT[<i>n</i>]:HEAD[<i>m</i>]:WAVelength:RESPonse?
syntax:	:SLOT[<i>n</i>]:HEAD[<i>m</i>]:WAVelength:RESPonse?
description:	Returns the wavelength response from a wavelength calibrated module in binary format.
response:	Wavelength Response table as a <i>binary block</i> .
response format:	One 8 byte long wavelength calibration value pair consisting of a 4 byte long float for wavelength and a 4 byte long float for the scalar calibration factor.
	For more information on binary block formats see " <i>Data Types</i> " on page 26
example:	slot1:head1:wav:resp? → #536570.....
affects:	Attenuator with power control, all powermeters, return loss modules

command:	:SLOT[<i>n</i>]:HEAD[<i>m</i>]:WAVelength:RESPonse:CSV?
syntax:	:SLOT[<i>n</i>]:HEAD[<i>m</i>]:WAVelength:RESPonse:CSV?
description:	Returns the wavelength response from the attenuator module in CSV format.
response:	Wavelength Response table as a <i>string</i>
response format:	The string is a comma separated value (CSV) list and can be written to a file and be processed with a spreadsheet program. List format: $\lambda_1, c_1 \backslash n$ $\lambda_2, c_2 \backslash n$ $\lambda_n, c_n \backslash n$ "," separates wavelength and response factor "\n" = ASCII code 10 separate value pairs
example:	slot1:head1:wav:resp:csv? → 1200e-6,2.019\n 1210e-6,1.956\n...
affects:	Attenuator with power control, all powermeters, return loss modules

command:	:SLOT[<i>n</i>]:HEAD[<i>m</i>]:WAVelength:RESPonse:SIZE?
syntax:	:SLOT[<i>n</i>]:HEAD[<i>m</i>]:WAVelength:RESPonse:SIZE?
description:	Returns the number of elements in the wavelength response table.
response:	Number of elements in the wavelength table as an <i>integer</i> value
example:	slot2:head1:wav:resp:size? → 50<END>
affects:	Attenuator with power control, all powermeters, return loss modules

command:	:SPECial:REBoot
syntax:	:SPECial:REBoot
description:	Reboots the mainframe and all modules.
parameters:	none
response:	none
example:	spec:reb

Measurement Functions – The SENSE Subsystem

The SENSE subsystem lets you control measurement parameters for a Power Sensor, an Optical Head Interface module, or a return loss module.

Agilent 81635A and Agilent 81619A - Master and Slave Channels

For the Agilent 81635A Dual Power Sensor and Agilent 81619A Dual Optical Head Interface module, channel 1 is the master channel and channel 2 is the slave channel. The master and slave channels share the same software and hardware triggering system. For some commands, setting parameters for the master channel sets the parameters for the slave channel. In these cases, you may only set parameters for the slave channel by setting master channel parameters.

The commands listed in Table 5 can only be configured using the master channel.

Table 5 Commands that can only be configured using the master channel

Command	Page
:INITiate[n]:[CHANnel[m]][:IMMEDIATE]	page 88
:INITiate[n]:[CHANnel[m]]:CONTinuous/?	page 89
:READ[n]:[CHANnel[m]][:SCALar]:POWer[:DC]?	page 90
:SENSe[n]:[CHANnel[m]]:CORRection:COLLect:ZERO	page 92
:SENSe[n]:[CHANnel[m]]:FUNcTion:PARAmeter:LOGGing/?	page 94
:SENSe[n]:[CHANnel[m]]:FUNcTion:PARAmeter:MINMax/?	page 95
:SENSe[n]:[CHANnel[m]]:FUNcTion:PARAmeter:STABility/?	page 96
:SENSe[n]:[CHANnel[m]]:FUNcTion:STATe/?	page 100
:SENSe[n]:[CHANnel[m]]:POWer:ATIME/?	page 101
:SENSe[n]:[CHANnel[m]]:POWer:RANGe:AUTO/?	page 104
:TRIGger[n]:[CHANnel[m]]:INPut/?	page 173
:TRIGger[n]:[CHANnel[m]]:INPut:REARm/?	page 174
:TRIGger[n]:[CHANnel[m]]:OUTPut/?	page 176
:TRIGger[n]:[CHANnel[m]]:OUTPut:REARm/?	page 177

The commands listed in Table 6 are independent for both master and slave channels.

Table 6 Commands that are independent for both master and slave channels

Command	Page
:FETCh[n]:CHANnel[m]:SCAlar:POWer[:DC]?	page 87
:ROUte[n]:CHANnel[m]/?	page 169
:ROUte[n]:CHANnel[m]:CONFig?	page 170
:ROUte[n]:CHANnel[m]:CONFig:ROUte?	page 170
:SENSe[n]:CHANnel[m]:CORRection[:LOSS][:INPut] [:MAGNI-tude]/?	page 92
:SENSe[n]:CHANnel[m]:CORRection:COLLect:ZERO?	page 93
:SENSe[n]:CHANnel[m]:CORRection:COLLect:ZERO:ALL	page 93
:SENSe[n]:CHANnel[m]:FUNction:RESult?	page 97
:SENSe[n]:CHANnel[m]:POWer:RANGe[:UPPer]/?	page 102
:SENSe[n]:CHANnel[m]:POWer:REFerence/?	page 105
:SENSe[n]:CHANnel[m]:POWer:REFerence:DISPlay	page 106
:SENSe[n]:CHANnel[m]:POWer:REFerence:STATe/?	page 106
:SENSe[n]:CHANnel[m]:POWer:REFerence:STATe:RATIo/?	page 107
:SENSe[n]:CHANnel[m]:POWer:UNIT/?	page 108
:SENSe[n]:CHANnel[m]:POWer:WAVelength/?	page 108

command:	:FETCh[n]:[CHANnel[m]][:SCAlar]:POWer[:DC]?
syntax:	:FETCh[n]:[CHANnel[m]][:SCAlar]:POWer[:DC]?
description:	<p>Reads the current power meter value, or for a return loss module returns current power value at return loss diode (back reflection path). It does not provide its own triggering and so must be used with either continuous software triggering (see “:INITiate[n]:[CHANnel[m]]:CONTinuous?” on page 89) or a directly preceding immediate software trigger (see “:INITiate[n]:[CHANnel[m]][:IMMEDIATE]” on page 88).</p> <p>It returns the value the previous software trigger measured. Any subsequent FETCh command will return the same value, if there is no subsequent software trigger.</p>
parameters:	none
response:	The current value as a float value in dBm,W or dB.
NOTE	<p>If the reference state is absolute, units are dBm or W. If the reference state is relative, units are dB.</p>
example:	fec1:pow? → +6.73370400E-04<END>
affects:	All power meters, return loss modules, and attenuators with power sensors
dual sensors:	Master and slave channels are independent.

command:	:FETCh[n]:[CHANnel[m]][:SCAlar]:RETurnloss?
syntax:	:FETCh[n]:[CHANnel[m]][:SCAlar]:RETurnloss?
description:	<p>Reads the current return loss value. It does not provide its own triggering and so must be used with either continuous software triggering (see “:INITiate[n]:[CHANnel[m]]:CONTinuous?” on page 89) or a directly preceding immediate software trigger (see “:INITiate[n]:[CHANnel[m]][:IMMEDIATE]” on page 88).</p> <p>It returns the return loss value the previous software trigger measured. Any subsequent FETCh command will return the same value, if there is no subsequent software trigger.</p>
parameters:	none
response:	The current value as a float value in dB.
example:	fec1:ret? → +6.73370400E-00<END>
affects:	All return loss modules

command:	:FETCh[n]:[CHANnel[m]][:SCAlar]:MONitor?
syntax:	:FETCh[n]:[CHANnel[m]][:SCAlar]:MONitor?
description:	<p>Reads current power value at a return loss module's monitor diode (forward path). It does not provide its own triggering and so must be used with either continuous software triggering (see “:INITiate[n]:[CHANnel[m]]:CONTinuous?” on page 89) or a directly preceding immediate software trigger (see “:INITiate[n]:[CHANnel[m]][:IMMediate]” on page 88).</p> <p>It returns the monitor value the previous software trigger measured. Any subsequent FETCH command will return the same value, if there is no subsequent software trigger.</p>
parameters:	none
response:	The current value as a float value in W or dBm.
example:	fetc1:mon? → +6.73370400E-00<END>
affects:	All return loss modules

command:	:INITiate[n]:[CHANnel[m]][:IMMediate]
syntax:	:INITiate[n]:[CHANnel[m]][:IMMediate]
description:	Initiates the software trigger system and completes one full trigger cycle, that is, one measurement is made.
parameters:	none
response:	none
example:	init
affects:	All power meters, return loss modules.
dual sensors:	Can only be sent to master channel, slave channel is also affected.

command:	:INITiate[n]:[CHANnel[m]]:CONTinuous
syntax:	:INITiate[n]:[CHANnel[m]]:CONTinuous<wsp><boolean>
description:	Sets the software trigger system to continuous measurement mode.
parameters:	<p>A <i>boolean</i> value: 0 or OFF: do not measure continuously 1 or ON: measure continuously</p>
response:	none
example:	init2:cont 1
affects:	All power meters, return loss modules.
dual sensors:	Can only be sent to master channel, slave channel is also affected.

command:	:INITiate[n]:[CHANnel[m]]:CONTInuous?
syntax:	:INITiate[n]:[CHANnel[m]]:CONTInuous?
description:	Queries whether the software trigger system operates continuously or not
parameters:	none
response:	A <i>boolean</i> value: 0 or OFF: measurement is not continuous 1 or ON: measurement is continuous
example:	init2:cont? → 1<END>
affects:	All power meters, return loss modules.
dual sensors:	Can only be sent to master channel, slave channel parameters are identical.

command:	:READ[n]:[CHANnel[m]][SCALar]:POWer:ALL?
syntax:	:READ[n]:[CHANnel[m]]:POWer[:DC]:ALL?
description:	Reads all available power meter channels. It provides its own software triggering and does not need a triggering command.
NOTE	The power meters must be running for this command to be effective.
parameters:	none
response:	4-byte Intel <i>float</i> values in a binary block in Intel byte order. The values are ordered by slot and channel order. See “ <i>Data Types</i> ” on page 26 for more information on Binary Blocks.
NOTE	Data values are always in Watt.
example:	read1:pow:all? → interpreted as +1.33555600E-006 +1.34789100E-006 +1.37456900E-006<END>
affects:	All power meters (v3.0x firmware or later).
dual sensors:	Master channels receive a read command, see: “:READ[n]:[CHANnel[m]][SCALar]:POWer[:DC]?” on page 90 Slave channels receive a fetch command, see: “:FETCH[n]:[CHANnel[m]][SCALar]:POWer[:DC]?” on page 87.

command:	:READ[n]:CHANnel[m]:POWer:ALL:CONFig?
syntax:	:READ[n]:[CHANnel[m]]:POWer[:DC]:ALL:CONFig?
description:	Returns the slot and channel numbers for all available power meter channels. Use this command to match returned power values to the appropriate slot and channel number.
parameters:	none
response:	A binary block (Intel byte order) consisting of 2-byte unsigned integer value pairs (so each pair has 4 bytes). The first member of the pair represents the the slot number, the second member of the pair represents the channel number.
example:	read1:pow:all:conf? → interpreted as 1 1 1 2 12 1<END> This 12-byte block means that there are three powermeters present: Slot 1, Channel 1 Slot 1, Channel 2 Slot 12, Channel 1
affects:	All power meters (v3.0x firmware or later).
dual sensors:	

command:	:READ[n]:CHANnel[m]][:SCALar]:POWer[:DC]?
syntax:	:READ[n]:[CHANnel[m]][:SCALar]:POWer[:DC]?
description:	Reads the current power meter value, or for a return loss module the power value at the return loss diode (back reflection path). It provides its own software triggering and does not need a triggering command. If the software trigger system operates continuously (see “:INITiate[n]:[CHANnel[m]]:CONTinuous?” on page 89), this command is identical to “:FETCh[n]:[CHANnel[m]][:SCALar]:POWer[:DC]?” on page 87. If the software trigger system does not operate continuously, this command is identical to generating a software trigger (“:INITiate[n]:[CHANnel[m]][:IMMEDIATE]” on page 88) and then reading the power meter value.
NOTE	The power meter must be running for this command to be effective.
parameters:	none
response:	The current power meter reading as a <i>float</i> value in dBm, W or dB.
NOTE	If the reference state is absolute, units are dBm or W. If the reference state is relative, units are dB.
example:	read1:pow? → +1.33555600E-006<END>
affects:	All power meters and return loss modules and attenuator with power control
dual sensors:	Can only be sent to master channel, slave channel is also triggered. To read a simultaneous result from the slave channel, send “:FETCh[n]:[CHANnel[m]][:SCALar]:POWer[:DC]?” on page 87 directly after this command.

command:	:READ[n]:CHANnel[m]:SCALar:RETurnloss?
syntax:	:READ[n]:CHANnel[m]:SCALar:RETurnloss?
description:	<p>Reads the current return loss value. It provides its own software triggering and does not need a triggering command.</p> <p>If the software trigger system operates continuously (see “:INITiate[n]:CHANnel[m]:CONTinuous?” on page 89), this command is identical to “:FETCh[n]:CHANnel[m]:SCALar:RETurnloss?” on page 87.</p> <p>If the software trigger system does not operate continuously, this command is identical to generating a software trigger (“:INITiate[n]:CHANnel[m]:IMMEDIATE” on page 88) and then reading the power meter value.</p>
NOTE	The return loss module must be running for this command to be effective.
parameters:	none
response:	The current power meter reading as a <i>float</i> value in dB.
example:	read1:ret? → +1.33555600E-000<END>
affects:	All return loss modules

command:	:READ[n]:CHANnel[m]:SCALar:MONitor?
syntax:	:READ[n]:CHANnel[m]:SCALar:MONitor?
description:	<p>Reads the power value at the monitor diode (forward path). It provides its own software triggering and does not need a triggering command.</p> <p>If the software trigger system operates continuously (see “:INITiate[n]:CHANnel[m]:CONTinuous?” on page 89), this command is identical to “:FETCh[n]:CHANnel[m]:SCALar:MONitor?” on page 88.</p> <p>If the software trigger system does not operate continuously, this command is identical to generating a software trigger (“:INITiate[n]:CHANnel[m]:IMMEDIATE” on page 88) and then reading the power meter value.</p>
NOTE	The return loss module must be running for this command to be effective.
parameters:	none
response:	The current power meter reading as a <i>float</i> value in W or dBm
example:	read1:mon? → +1.33555600E-000<END>
affects:	All return loss modules

command:	:SENSe[n]:[CHANnel[m]]:CORRection[:LOSS][:INPut][:MAGNitude]
syntax:	:SENSe[n]:[CHANnel[m]]:CORRection[:LOSS][:INPut][:MAGNitude]<wsp> <value>[DB MDB]
description:	Enters a calibration value for a module.
parameters:	The calibration factor as a <i>float</i> value If no unit type is specified, decibels (dB) is implied.
response:	none
example:	sens1:corr 10DB
affects:	All power meters
dual sensors:	Master and slave channels are independent.

command:	:SENSe[n]:[CHANnel[m]]:CORRection[:LOSS][:INPut][:MAGNitude]?
syntax:	:SENSe[n]:[CHANnel[m]]:CORRection[:LOSS][:INPut][:MAGNitude]?
description:	Returns the calibration factor for a module.
parameters:	none
response:	The calibration factor as a <i>float</i> value. Units are in dB, although no units are returned in the response message.
example:	sens1:corr? → +1.00000000E+000<END>
affects:	All power meters
dual sensors:	Master and slave channels are independent.

command:	:SENSe[n]:[CHANnel[m]]:CORRection:COLLect:ZERO
syntax:	:SENSe[n]:[CHANnel[m]]:CORRection:COLLect:ZERO
description:	Zeros the electrical offsets for a power meter or return loss module.
parameters:	none
response:	none
example:	sens1:corr:coll:zero
affects:	All power meters and return loss modules
dual sensors:	Can only be sent to master channel, slave channel is also zeroed.

command:	:SENSE[n]:[CHANnel[m]]:CORRection:COLLect:ZERO?
syntax:	:SENSE[n]:[CHANnel[m]]:CORRection:COLLect:ZERO?
description:	Returns the status of the most recent zero command.
parameters:	none
response:	0: zero succeeded without errors. any other number: remote zeroing failed (the number is the error code returned from the operation).
example:	sens1:corr:coll:zero? → 0<END>
affects:	All power meters and return loss modules
dual sensors:	Master and slave channels are independent.

command:	:SENSE[n]:[CHANnel[m]]:CORRection:COLLect:ZERO:ALL
syntax:	SENSE[n]:[CHANnel[m]]:CORRection:COLLect:ZERO:ALL
description:	Zeros the electrical offsets for all installed power meter and return loss modules.
parameters:	none
response:	none
example:	sens:chan:corr:coll:zero:all
affects:	All power meters and return loss modules
dual sensors:	Command is independent of channel.

NOTE

Setting parameters for the logging function sets some parameters, including hidden parameters, for the stability and MinMax functions and vice versa. You must use the :SENSE[n]:[CHANnel[m]]:FUNCTION:PARAMeter:LOGGing command to set parameters before you start a logging function using the :SENSE[n]:[CHANnel[m]]:FUNCTION:STATe command.

command:	:SENSe[n][:CHANnel[m]]:FUNction:PARAmeter:LOGGing
syntax:	:SENSe[n][:CHANnel[m]]:FUNction:PARAmeter:LOGGing<wsp><data points>, <averaging time>[NS US MS S]
description:	Sets the number of data points and the averaging time for the logging data acquisition function.
parameters:	<p>Data Points: Data Points is the number of samples that are recorded before the logging mode is completed. Data Points is an integer value.</p> <p>Averaging time: Averaging time is a time value in seconds. There is no time delay between averaging time periods. Use <i>“:SENSe[n][:CHANnel[m]]:FUNction:PARAmeter:STABility?”</i> on page 97 if you want to use delayed measurement.</p>
<p>The diagram shows a horizontal axis labeled 't' representing time. A vertical arrow points upwards from the axis, labeled 'Measurement Running'. Below the axis, a series of nine numbered boxes (1 through 9) represent data points. A double-headed arrow above boxes 3 and 4 is labeled 'Averaging Time', indicating the duration over which data points are averaged.</p>	
NOTE	If you specify no units for the averaging time value in your command, seconds are used as the default.
NOTE	See <i>“:SENSe[n][:CHANnel[m]]:FUNction:STATe”</i> on page 100 for information on starting/stopping a data acquisition function.
NOTE	See <i>“:SENSe[n][:CHANnel[m]]:FUNction:RESult?”</i> on page 97 for information on accessing the results of a data acquisition function.
NOTE	See <i>“Triggering and Power Measurements”</i> on page 171 for information on how triggering affects data acquisition functions.
response:	none
example:	sens1:func:par:logg 64,1ms
affects:	All power meters and return loss modules
dual sensors:	Can only be sent to master channel, slave channel is also affected.

command:	:SENSe[n][:CHANnel[m]]:FUNction:PARAmeter:LOGGing?
syntax:	:SENSe[n][:CHANnel[m]]:FUNction:PARAmeter:LOGGing?
description:	Returns the number of data points and the averaging time for the logging data acquisition function.
parameters:	none
response:	Returns the number of data points as an integer value and the averaging time, t_{avg} , as a float value in seconds.
example:	sens1:func:par:logg? → +64,+1.00000000E-001<END>
affects:	All power meters and return loss modules
dual sensors:	Can only be sent to master channel, slave channel parameters are identical.

NOTE

Setting parameters for the MinMax function sets some parameters, including hidden parameters, for the stability and logging functions and vice versa. You must use the `:SENSE[n][:CHANnel[m]]:FUNCTION:PARAmeter:MINMax` command to set parameters before you start a MinMax function using the `:SENSE[n][:CHANnel[m]]:FUNCTION:STATe` command.

command:	:SENSE[n][:CHANnel[m]]:FUNCTION:PARAmeter:MINMax
syntax:	:SENSE[n][:CHANnel[m]]:FUNCTION:PARAmeter:MINMax<wsp> CONTinuous WINDow REFResh,<data points>
description:	Sets the MinMax mode and the number of data points for the MinMax data acquisition function.
parameters:	CONTinuous: continuous MinMax mode WINDow: window MinMax mode REFResh: refresh MinMax mode Data Points is the number of samples that are recorded in the memory buffer used by the WINDow and REFResh modes. Data Points is an integer value. See Chapter 3 of the Agilent 8163A/B Lightwave Multimeter, Agilent 8164A/B Lightwave Measurement System, & Agilent 8166A/B Lightwave Multichannel System User's Guide, for more information on MinMax mode.
NOTE	See “:SENSE[n][:CHANnel[m]]:FUNCTION:STATe” on page 100 for information on starting/stopping a data acquisition function.
NOTE	See “:SENSE[n][:CHANnel[m]]:FUNCTION:RESult?” on page 97 for information on accessing the results of a data acquisition function.
NOTE	See “Triggering and Power Measurements” on page 171 for information on how triggering affects data acquisition functions.
response:	none
example:	sens1:func:par:minm WIND,10
affects:	All power meters and return loss modules
dual sensors:	Can only be sent to master channel, slave channel is also affected.

command:	:SENSE[n][:CHANnel[m]]:FUNCTION:PARAmeter:MINMax?
syntax:	:SENSE[n][:CHANnel[m]]:FUNCTION:PARAmeter:MINMax?
description:	Returns the MinMax mode and the number of data points for the MinMax data acquisition function.
parameters:	none
response:	CONT: continuous MinMax mode WIND: window MinMax mode REFR: refresh MinMax mode The number of data points is returned as an integer value.

example:	sens1:func:par:minm? → WIND,+10<END>
affects:	All power meters and return loss modules
dual sensors:	Can only be sent to master channel, slave channel parameters are identical.

NOTE

Setting parameters for the stability function sets some parameters, including hidden parameters, for the logging and MinMax functions and vice versa. You must use the :SENSE[n][:CHANnel[m]]:FUNctio:n:PARameter:STABility command to set parameters before you start a stability function using the :SENSE[n][:CHANnel[m]]:FUNctio:n:STATe command.

command:	:SENSE[n][:CHANnel[m]]:FUNctio:n:PARameter:STABility
syntax:	:SENSE[n][:CHANnel[m]]:FUNctio:n:PARameter:STABility<wsp> <total time>[NS US MS S],<period time>[NS US MS S],<averaging time>[NS US MS S]
description:	Sets the total time, period time, and averaging time for the stability data acquisition function.
parameters:	Total time: The total time from the start of stability mode until it is completed. Period time: A new measurement is started after the completion of every period time. Averaging time: A measurement is averaged over the averaging time.

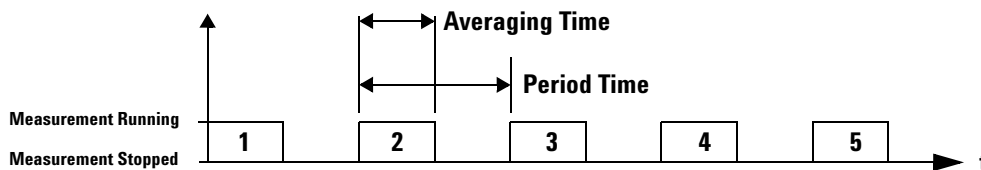

NOTE	The total time should be longer than the period time. The period time should be longer than the averaging time. The number of data points is equal to the total time divided by the period time. Total time, period time, and averaging time are time values in seconds. If you specify no units in your command, seconds are used as the default.
NOTE	See “:SENSE[n][:CHANnel[m]]:FUNctio:n:STATe” on page 100 for information on starting/stopping a data acquisition function.
NOTE	See “:SENSE[n][:CHANnel[m]]:FUNctio:n:RESult?” on page 97 for information on accessing the results of a data acquisition function.
NOTE	See “Triggering and Power Measurements” on page 171 for information on how triggering affects data acquisition functions.
response:	none
example:	sens1:func:par:stab 1s,0.1s,0.1s
affects:	All power meters and return loss modules
dual sensors:	Can only be sent to master channel, slave channel is also affected.

command:	:SENSe[n][:CHANnel[m]]:FUNction:PARAmeter:STABility?
syntax:	:SENSe[n][:CHANnel[m]]:FUNction:PARAmeter:STABility?
description:	Returns the total time, period time, and averaging time for the stability data acquisition function.
parameters:	none
response:	Total time, delay time, and averaging time are float values in seconds.
example:	sens1:func:par:stab? → +1.00000000E+000, +1.00000000E-001,+1.00000000E-001<END>
affects:	All power meters and return loss modules
dual sensors:	Can only be sent to master channel, slave channel parameters are identical.

command:	:SENSe[n][:CHANnel[m]]:FUNction:RESult?
syntax:	:SENSe[n][:CHANnel[m]]:FUNction:RESult?
description:	Returns the data array of the last data acquisition function.
parameters:	none
response:	The last data acquisition function's data array as a binary block. For Logging and Stability Data Acquisition functions, one measurement value is a 4-byte-long float in Intel byte order. For the MinMax Data Acquisition function, the query returns the minimum, maximum and current power values. See "Data Types" on page 26 for more information on Binary Blocks.
	NOTE See "How to Log Results" on page 207 for information on logging using VISA calls. There are some tips about how to use float format specifiers to convert the binary blocks into float values.
	NOTE If you use LabView or Agilent VEE, we recommend using the Agilent 816x VXIplug&play Instrument Driver to perform the Logging and Stability Data Acquisition functions.
example:	sens1:func:res? → returns a data array for Logging and Stability Data Acquisition functions sens1:func:res? → #255 Min: 7.24079E-04, Max: 7.24252E-04, Act: 7.24155E-04 returns the minimum, maximum and current power values for the MinMax Data Acquisition function
affects:	All power meters and return loss modules
dual sensors:	Master and slave channels are independent.
	NOTE Return Loss modules: For Logging and Stability Data Acquisition functions, the data array contains power values. For the MinMax Data Acquisition function, the data array contains return loss values.

command:	:SENSE[n][:CHANnel[m]]:FUNCTION:RESult:BLOCK?
syntax:	:SENSE[n][:CHANnel[m]]:FUNCTION:RESult:BLOCK?<wsp><offset>,<# of data points>
description:	Returns a specific binary block (Intel byte order) from the data array for the last data acquisition function.
parameters:	<offset> A zero based offset; the number of data points to ignore. <i># data points</i> The number of data points (not bytes!) to return.
response:	The last stability or logging data acquisition function's data array as a binary block. This function is not available for min-max measurements. One measurement value is a 4-byte-long float in Intel byte order. See "Data Types" on page 26 for more information on Binary Blocks.
example:	sens1:func:res:bloc? #5, 2 → interpreted as 7.24079E-04,7.24252E-04<end>
affects:	All power meters and return loss modules .
dual sensors:	Master and slave channels are independent.
NOTE	Return Loss modules: For Logging and Stability Data Acquisition functions, the data array contains power values.

command:	:SENSE[n][:CHANnel[m]]:FUNCTION:RESult:MAXBlocksize?
syntax:	:SENSE[n][:CHANnel[m]]:FUNCTION:RESult:MAXBlocksize?<wsp><offset><# of data points>
description:	Returns the maximum block size for a single GPIB transfer for power meter data acquisition functions. If your application requires more data points please use SENSE[n][:CHANnel[m]]:FUNCTION:RESult:BLOCK? instead of SENSE[n][:CHANnel[m]]:FUNCTION:RESult?
parameters:	none
response:	An integer value, number of data points. See "Data Types" on page 26 for more information on Binary Blocks.
example:	
affects:	All power meters and return loss modules.
dual sensors:	Master and slave channels are independent.

command:	:SENSe[n][:CHANnel[m]]:FUNction:RESult:MONitor?
syntax:	:SENSe[n][:CHANnel[m]]:FUNction:RESult:MONitor?
description:	Returns the monitor diode data array for the last data acquisition function.
parameters:	none
response:	The last data acquisition function's data array as a binary block. For Logging and Stability Data Acquisition functions, one measurement value is a 4-byte-long float in Intel byte order. For the MinMax Data Acquisition function, the query returns the minimum, maximum and current power values. See <i>"Data Types"</i> on page 26 for more information on Binary Blocks.
NOTE	See <i>"How to Log Results"</i> on page 207 for information on logging using VISA calls. There are some tips about how to use float format specifiers to convert the binary blocks into float values.
NOTE	If you use LabView or Agilent VEE, we recommend using the Agilent 816x VXiplug&play Instrument Driver to perform the Logging and Stability Data Acquisition functions.
example:	sens1:func:res:mon? → returns a data array for Logging and Stability Data Acquisition functions sens1:func:res? → #255 Min: 7.24079E-04, Max: 7.24252E-04, Act: 7.24155E-04 returns the minimum, maximum and current power values for the MinMax Data Acquisition function
affects:	All return loss modules
dual sensors:	Master and slave channels are independent.
NOTE	Return Loss modules: For Logging and Stability Data Acquisition functions, the data array contains power values for the monitor diode. For the MinMax Data Acquisition function, the data array contains return loss values for the monitor diode.

command:	:SENSe[n][:CHANnel[m]]:FUNctioN:STATe
syntax:	:SENSe[n][:CHANnel[m]]:FUNctioN:STATe<wsp> LOGGing STABility MINMax,STOP START
description:	Enables/Disables the logging, MinMax, or stability data acquisition function mode.
parameters:	LOGGing: Logging data acquisition function STABility: Stability data acquisition function MINMax: MinMax data acquisition function STOP: Stop data acquisition function START: Start data acquisition function
NOTE	When you enable a logging data acquisition function for a Agilent 8163A/B Series Power Meter with averaging time of less than 100 ms with input hardware triggering disabled, all GPIB commands will be ignored for the duration of the function. See “:SENSe[n][:CHANnel[m]]:FUNctioN:PARAmeter:LOGGing” on page 94 for more information on the logging data acquisition function.
NOTE	Stop any function before you try to set up a new function. Some parameters cannot be set until you stop the function.
response:	none
example:	sens1:func:stat logg,star
affects:	All power meters and return loss modules
dual sensors:	Can only be sent to master channel, slave channel is also affected.

command:	:SENSe[n][:CHANnel[m]]:FUNctioN:STATe?
syntax:	:SENSe[n][:CHANnel[m]]:FUNctioN:STATe?
description:	Returns the function mode and the status of the data acquisition function.
parameters:	none
response:	NONE No function mode selected LOGGING_STABILITY Logging or stability data acquisition function MINMAX MinMax data acquisition function PROGRESS Data acquisition function is in progress COMPLETE Data acquisition function is complete
example:	sens1:func:stat? → LOGGING_STABILITY,COMPLETE<END>
affects:	All power meters and return loss modules
dual sensors:	Can only be sent to master channel, slave channel parameters are identical.

command:	:SENSe[n][:CHANnel[m]]:FUNctio:THReshold
syntax:	:SENSe[n][:CHANnel[m]]:FUNctio:THReshold<wsp><mode>,<threshold value>[PW NW UW MW Watt DBM]
description:	Sets the start mode and the threshold value.
parameters:	<p>ABOVe: Function starts when power is above the threshold value.</p> <p>BELow: Function starts when power is below the threshold value.</p> <p>IMMediately: Function starts immediately.</p> <p>Threshold Value: A float value in Watts or dBm.</p>
response:	none
example:	sens1:func:thr IMM,20nw<END>
affects:	All HP 8153A Lightwave Multimeter series power meters and the HP 81534A Return Loss module
NOTE	Does NOT affect Agilent 8161x series return loss modules

command:	:SENSe[n][:CHANnel[m]]:FUNctio:THReshold?
syntax:	:SENSe[n][:CHANnel[m]]:FUNctio:THReshold?
description:	Returns the start mode and the threshold value.
parameters:	none
response:	<p>ABOV: Function starts when power is above the threshold value.</p> <p>BEL: Function starts when power is below the threshold value.</p> <p>IMM: Function starts immediately.</p> <p>Threshold Value: A float value in Watts or dBm.</p>
example:	sens1:func:thr? → IMM,+2.00000000E-008<END>
affects:	All HP 8153A Lightwave Multimeter series power meters and the HP 81534A Return Loss module
NOTE	Does NOT affect Agilent 8161x series return loss modules

command:	:SENSe[n][:CHANnel[m]]:POWer:ATIME
syntax:	:SENSe[n][:CHANnel[m]]:POWer:ATIME<wsp><averaging time>[NS US MS S]
description:	Sets the averaging time for the module.
parameters:	<p>The averaging time as a float value in seconds.</p> <p>If you specify no units in your command, seconds are used as the default.</p>
response:	none
example:	sens1:pow:atim 1s
affects:	All power meters and return loss modules
dual sensors:	Can only be sent to master channel, slave channel is also affected.

command:	:SENSE[n]:[CHANnel[m]]:POWER:ATIME?
syntax:	:SENSE[n]:[CHANnel[m]]:POWER:ATIME?
description:	Returns the averaging time for the module.
parameters:	none
response:	The averaging time as a <i>float</i> value in seconds.
example:	sens1:pow:atim? → +1.0000000E+000<END>
affects:	All power meters and return loss modules
dual sensors:	Can only be sent to master channel, slave channel parameters are identical.

command:	:SENSE[n]:[CHANnel[m]]:POWER:RANGe[:UPPer]																																				
syntax:	:SENSE[n]:[CHANnel[m]]:POWER:RANGe[:UPPer]<wsp><value>[DBM]																																				
description:	<p>Sets the power range for the module. For a return loss module, sets the power range of the return loss diode.</p> <p>The range changes at 10 dBm intervals. The corresponding ranges for linear measurements (measurements in Watts) is given below:</p> <table border="1"> <thead> <tr> <th>Range</th> <th>Upper Linear Power Limit</th> <th>Range</th> <th>Upper Linear Power Limit</th> </tr> </thead> <tbody> <tr> <td>+30 dBm</td> <td>1999.9 mW</td> <td>-50 dBm</td> <td>19.999 nW</td> </tr> <tr> <td>+20 dBm</td> <td>199.99 mW</td> <td>-60 dBm</td> <td>1999.9 pW</td> </tr> <tr> <td>+10 dBm</td> <td>19.999 mW</td> <td>-70 dBm</td> <td>199.99 pW</td> </tr> <tr> <td>0 dBm</td> <td>1999.9 μW</td> <td>-80 dBm</td> <td>19.999 pW</td> </tr> <tr> <td>-10 dBm</td> <td>199.99 μW</td> <td>-90 dBm</td> <td>1.999 pW</td> </tr> <tr> <td>-20 dBm</td> <td>19.999 μW</td> <td>-100 dBm</td> <td>0.199 pW</td> </tr> <tr> <td>-30 dBm</td> <td>1999.9 nW</td> <td>-110 dBm</td> <td>0.019 pW</td> </tr> <tr> <td>-40 dBm</td> <td>199.99 nW</td> <td></td> <td></td> </tr> </tbody> </table>	Range	Upper Linear Power Limit	Range	Upper Linear Power Limit	+30 dBm	1999.9 mW	-50 dBm	19.999 nW	+20 dBm	199.99 mW	-60 dBm	1999.9 pW	+10 dBm	19.999 mW	-70 dBm	199.99 pW	0 dBm	1999.9 μW	-80 dBm	19.999 pW	-10 dBm	199.99 μW	-90 dBm	1.999 pW	-20 dBm	19.999 μW	-100 dBm	0.199 pW	-30 dBm	1999.9 nW	-110 dBm	0.019 pW	-40 dBm	199.99 nW		
Range	Upper Linear Power Limit	Range	Upper Linear Power Limit																																		
+30 dBm	1999.9 mW	-50 dBm	19.999 nW																																		
+20 dBm	199.99 mW	-60 dBm	1999.9 pW																																		
+10 dBm	19.999 mW	-70 dBm	199.99 pW																																		
0 dBm	1999.9 μW	-80 dBm	19.999 pW																																		
-10 dBm	199.99 μW	-90 dBm	1.999 pW																																		
-20 dBm	19.999 μW	-100 dBm	0.199 pW																																		
-30 dBm	1999.9 nW	-110 dBm	0.019 pW																																		
-40 dBm	199.99 nW																																				
parameters:	The range as a float value in dBm. The number is rounded to the closest multiple of 10, because the range changes at 10 dBm intervals. Units are in dBm.																																				
response:	none																																				
example:	sens1:pow:rang -20DBM																																				
affects:	All power meters and return loss modules.																																				
dual sensors:	Master and slave channels are independent.																																				

command:	:SENSe[n]:[CHANnel[m]]:POWer:RANGe[:UPPer]?
syntax:	:SENSe[n]:[CHANnel[m]]:POWer:RANGe[:UPPer]?
description:	Returns the range setting for the module. For a return loss module, returns the power range of the return loss diode.
parameters:	none
response:	The range setting as a <i>float</i> value in dBm ($-110 \leq \text{value} \leq +30$).
example:	sens1:pow:rang? → -2.00000000E+001<END>
affects:	All power meters and return loss modules.
dual sensors:	Master and slave channels are independent.

command:	:SENSe[n]:[CHANnel[m]]:POWer:RANGe:MONitor[:UPPer]																																				
syntax:	:SENSe[n]:[CHANnel[m]]:POWer:RANGe:MONitor[:UPPer]<wsp><value>[DBM]																																				
description:	Sets the power range for a return loss module's monitor diode. The range changes at 10 dBm intervals. The corresponding ranges for linear measurements (measurements in Watts) is given below:																																				
	<table border="1"> <thead> <tr> <th>Range</th> <th>Upper Linear Power Limit</th> <th>Range</th> <th>Upper Linear Power Limit</th> </tr> </thead> <tbody> <tr> <td>+30 dBm</td> <td>1999.9 mW</td> <td>-50 dBm</td> <td>19.999 nW</td> </tr> <tr> <td>+20 dBm</td> <td>199.99 mW</td> <td>-60 dBm</td> <td>1999.9 pW</td> </tr> <tr> <td>+10 dBm</td> <td>19.999 mW</td> <td>-70 dBm</td> <td>199.99 pW</td> </tr> <tr> <td>0 dBm</td> <td>1999.9 μW</td> <td>-80 dBm</td> <td>19.999 pW</td> </tr> <tr> <td>-10 dBm</td> <td>199.99 μW</td> <td>-90 dBm</td> <td>1.999 pW</td> </tr> <tr> <td>-20 dBm</td> <td>19.999 μW</td> <td>-100 dBm</td> <td>0.199 pW</td> </tr> <tr> <td>-30 dBm</td> <td>1999.9 nW</td> <td>-110 dBm</td> <td>0.019 pW</td> </tr> <tr> <td>-40 dBm</td> <td>199.99 nW</td> <td></td> <td></td> </tr> </tbody> </table>	Range	Upper Linear Power Limit	Range	Upper Linear Power Limit	+30 dBm	1999.9 mW	-50 dBm	19.999 nW	+20 dBm	199.99 mW	-60 dBm	1999.9 pW	+10 dBm	19.999 mW	-70 dBm	199.99 pW	0 dBm	1999.9 μW	-80 dBm	19.999 pW	-10 dBm	199.99 μW	-90 dBm	1.999 pW	-20 dBm	19.999 μW	-100 dBm	0.199 pW	-30 dBm	1999.9 nW	-110 dBm	0.019 pW	-40 dBm	199.99 nW		
Range	Upper Linear Power Limit	Range	Upper Linear Power Limit																																		
+30 dBm	1999.9 mW	-50 dBm	19.999 nW																																		
+20 dBm	199.99 mW	-60 dBm	1999.9 pW																																		
+10 dBm	19.999 mW	-70 dBm	199.99 pW																																		
0 dBm	1999.9 μW	-80 dBm	19.999 pW																																		
-10 dBm	199.99 μW	-90 dBm	1.999 pW																																		
-20 dBm	19.999 μW	-100 dBm	0.199 pW																																		
-30 dBm	1999.9 nW	-110 dBm	0.019 pW																																		
-40 dBm	199.99 nW																																				
parameters:	The range as a float value in dBm. The number is rounded to the closest multiple of 10, because the range changes at 10 dBm intervals. Units are in dBm.																																				
response:	none																																				
example:	sens1:pow:rang:mon -20DBM																																				
affects:	All return loss modules.																																				
dual sensors:	Master and slave channels are independent.																																				

command:	:SENSe[n]:[CHANnel[m]]:POWer:RANGe:MONitor[:UPPer]?
syntax:	:SENSe[n]:[CHANnel[m]]:POWer:RANGe[:UPPer]?
description:	Sets the power range for a return loss module's monitor diode.
parameters:	none
response:	The range setting as a <i>float</i> value in dBm ($-110 \leq \text{value} \leq +30$).
example:	sens1:pow:rang? → -2.0000000E+001<END>
affects:	All return loss modules.
dual sensors:	Master and slave channels are independent.

command:	:SENSe[n]:[CHANnel[m]]:POWer:RANGe:AUTO
syntax:	SENSe[n]:[CHANnel[m]]:POWer:RANGe:AUTO <wsp><boolean>
description:	Enables or disables automatic power ranging for the module. If automatic power ranging is enabled, ranging is automatically determined by the instrument. Otherwise, it must be set by the sensn:pow:rang command.
parameters:	A <i>boolean</i> value: 0 or OFF: automatic ranging disabled 1 or ON: automatic ranging enabled
response:	none
example:	sens1:pow:rang:auto 1
affects:	All power meters and return loss modules
NOTE	For return loss modules, affects return loss diode and monitor diode simultaneously.
dual sensors:	Can only be sent to master channel, slave channel is also affected.

command:	:SENSe[n]:[CHANnel[m]]:POWer:RANGe:AUTO?
syntax:	:SENSe[n]:[CHANnel[m]]:POWer:RANGe:AUTO?
description:	Returns whether automatic power ranging is being used by the module.
parameters:	none
response:	A <i>boolean</i> value: 0: automatic ranging is not being used. 1: automatic ranging is being used.
example:	sens1:pow:rang:auto? → 1<END>
affects:	All power meters and return loss modules
dual sensors:	Can only be sent to master channel, slave channel parameters are identical.

command:	:SENSe[n]:[CHANnel[m]]:POWer:REFerence
syntax:	:SENSe[n]:[CHANnel[m]]:POWer:REFerence<wsp> TOMODule TOREF,<value>PW NW UW MW Watt DBM DB MDB
description:	Sets the sensor reference value.
parameters:	TOMODule: Sets the reference value in dB used if you choose measurement relative to another channel TOREF: Sets the reference value in Watts or dBm if you choose measurement relative to a constant reference value The reference as a float value.
NOTE	You must append a unit type <ul style="list-style-type: none"> • dB if you use TOMODule or • Watts or dBm if you use TOREF.
NOTE	The two reference values are completely independent. When you change the reference mode using the command <i>“:SENSe[n]:[CHANnel[m]]:POWer:REFerence:STATe:RATio”</i> on page 107, the instrument uses the last reference value entered for the selected reference mode.
response:	none
example:	sens1:pow:ref tomod,-40DB
affects:	All power meters
dual sensors:	Master and slave channels are independent.

command:	:SENSe[n]:[CHANnel[m]]:POWer:REFerence?
syntax:	:SENSe[n]:[CHANnel[m]]:POWer:REFerence?<wsp>TOMODule TOREF
description:	Returns the sensor reference value.
parameters:	TOMODule: Returns the reference value in dB used if you choose measurement relative to another channel TOREF: Returns the reference value in Watts or dBm if you choose measurement relative to a constant reference value The reference as a float value.
response:	The reference as a float value.
example:	sens1:pow:ref? toref → +1.00000000E-006<END>
affects:	All power meters
dual sensors:	Master and slave channels are independent.

command:	:SENSE[n]:[CHANnel[m]]:POWer:REFerence:DISPlay
syntax:	:SENSE[n]:[CHANnel[m]]:POWer:REFerence:DISPlay
description:	Takes the input power level value as the reference value.
parameters:	none
response:	none
example:	sens1:pow:ref:disp
affects:	All power meters
dual sensors:	Master and slave channels are independent.

command:	:SENSE[n]:[CHANnel[m]]:POWer:REFerence:STATe
syntax:	:SENSE[n]:[CHANnel[m]]POWer:REFerence:STATe<wsp><boolean>
description:	Sets the measurement units to relative or absolute units.
parameters:	A <i>boolean</i> value: 0 or OFF: absolute 1 or ON: relative
response:	none
example:	sens1:pow:ref:stat 1
affects:	All power meters
dual sensors:	Master and slave channels are independent.

command:	:SENSE[n]:[CHANnel[m]]:POWer:REFerence:STATe?
syntax:	:SENSE[n]:[CHANnel[m]]POWer:REFerence:STATe?
description:	Inquires whether the current measurement units are relative (dB) or absolute (Watts or dBm).
parameters:	none
response:	A <i>boolean</i> value: 0: absolute 1: relative
example:	sens1:pow:ref:stat? → 1<END>
affects:	All power meters
dual sensors:	Master and slave channels are independent.

command:	:SENSe[n]:[CHANnel[m]]:POWer:REFerence:STATe:RATio	
syntax:	:SENSe[n]:[CHANnel[m]]POWer:REFerence:STATe:RATio<wsp> <slot number> 255 TOREF,<channel number>	
description:	Selects the reference for the module.	
parameters:	slot number:	an integer value representing the slot number you want to reference
	255 or TOREF:	results are displayed relative to an absolute reference
	channel number:	an integer value representing the channel number you want to reference
	NOTE	If you want to reference another power sensor channel, use an integer value corresponding to the slot for the first parameter and an integer value corresponding to the channel for the second value. If you want to use an absolute reference, use TOREF as the first parameter and any integer value as the second parameter.
response:	none	
examples:	sens1:pow:ref:stat:rat 2,1	References channel 2.1
	sens1:pow:ref:stat:rat TOREF,1	References an absolute reference
affects:	All power meters	
dual sensors:	Master and slave channels are independent.	

command:	:SENSe[n]:[CHANnel[m]]:POWer:REFerence:STATe:RATio?	
syntax:	:SENSe[n]:[CHANnel[m]]POWer:REFerence:STATe:RATio?	
description:	Returns the reference setting for the module.	
parameters:	none	
response:	results are displayed relative to an absolute reference or to the current power reading from another channel.	
examples:	sens1:pow:ref:stat:rat? → +255,+0<END>	results are displayed relative to an absolute reference
	sens1:pow:ref:stat:rat? → +2,+1<END>	results are displayed relative to channel 2.1
affects:	All power meters	
dual sensors:	Master and slave channels are independent.	

command:	:SENSe[n]:[CHANnel[m]]:POWer:UNIT
syntax:	:SENSe[n]:[CHANnel[m]]:POWer:UNIT<wsp>DBM 0 Watt 1
description:	Sets the sensor power unit
parameters:	An <i>integer</i> value: 0: dBm 1: Watt or DBM or Watt
response:	none
example:	sens1:pow:unit 1
affects:	All power meters
dual sensors:	Master and slave channels are independent.

command:	:SENSe[n]:[CHANnel[m]]:POWer:UNIT?
syntax:	:SENSe[n]:[CHANnel[m]]:POWer:UNIT?
description:	Inquires the current sensor power unit
parameters:	none
response:	An <i>integer</i> value: 0: Current power units are dBm. 1: Current power units are Watts.
example:	sens1:pow:unit? → +1<END>
affects:	All power meters
dual sensors:	Master and slave channels are independent.

command:	:SENSe[n]:[CHANnel[m]]:POWer:WAVelength
syntax:	:SENSe[n]:[CHANnel[m]]:POWer:WAVelength<wsp><value> MIN MAX DEF [PM NM UM MM M]
description:	Sets the sensor wavelength.
parameters:	The wavelength as a <i>float</i> value in meters. Also allowed are: MIN: minimum programmable value MAX: maximum programmable value DEF: This is not the preset (*RST) default value but is half the sum of, the minimum programmable value and the maximum programmable value
response:	none
example:	sens1:pow:wav 1550nm
affects:	All power meters
dual sensors:	Master and slave channels are independent.

command:	:SENSe[n]:[CHANnel[m]]:POWer:WAVelength?
syntax:	:SENSe[n]:[CHANnel[m]]:POWer:WAVelength?[<wsp>MIN MAX DEF]
description:	Inquires the current sensor wavelength.
parameters:	none Also allowed are: MIN: minimum programmable value MAX: maximum programmable value DEF: This is not the preset (*RST) default value but is half the sum of, the minimum programmable value and the maximum programmable value
response:	The wavelength as a <i>float</i> value in meters.
example	sens1:pow:wav? → +1.55000000E-006<END>
affects:	All power meters
dual sensors:	Master and slave channels are independent.

command:	:SENSe[n]:[CHANnel[m]]:RETurnloss:CALibration:FACTory
syntax:	:SENSe[n]:[CHANnel[m]]:RETurnloss:CALibration:FACTory
description:	For all sources, overwrites the current calibration values with the factory-set calibration settings. See “:SENSe[n]:[CHANnel[m]]:RETurnloss:CALibration:COLlect:TERMination” on page 110 and “:SENSe[n]:[CHANnel[m]]:RETurnloss:CORRection:REFlectance[!]?” on page 112 for information on calibrating your return loss module.
parameters:	none
response:	none
example	sens1:ret:cal:fact
affects:	All return loss modules

command:	:SENSe[n]:[CHANnel[m]]:RETurnloss:CALibration:COLlect:REFlectance
syntax:	:SENSe[n]:[CHANnel[m]]:RETurnloss:CALibration:COLlect:REFlectance
description:	For the currently selected source, start the calibration and save the calibration values for a defined reflectance reference measurement. See “:SENSe[n]:[CHANnel[m]]:RETurnloss:CORRection:REFlectance[!]?” on page 112 for information on setting the return loss value of your reference reflector.
parameters:	none
response:	none
example	sens1:ret:cal:coll:refl
affects:	All return loss modules

command:	:SENSe[n]:[CHANnel[m]]:RETurnloss:CALibration:COLlect:TERMination
syntax:	:SENSe[n]:[CHANnel[m]]:RETurnloss:CALibration:COLlect:TERMination
description:	For the currently selected source, start the calibration and save the calibration values for a defined termination reference measurement. See “:SENSe[n]:[CHANnel[m]]:RETurnloss:CORRection:REFlectance[!]” on page 112 for information on setting the return loss value of your reference reflector.
parameters:	none
response:	none
example	sens1:ret:cal:coll:term
affects:	All return loss modules

command:	:SENSe[n]:[CHANnel[m]]:RETurnloss:CALibration:TERMination?
syntax:	:SENSe[n]:[CHANnel[m]]:RETurnloss:CALibration:TERMination?
description:	Queries the T-value (termination calibration value) for the return loss module
parameters:	none
response:	Termination calibration value as a float in dB
example	sens1:ret:cal:term? → +6.5000E+001
affects:	All return loss modules

command:	:SENSe[n]:[CHANnel[m]]:RETurnloss:CALibration:VALues?
syntax:	:SENSe[n]:[CHANnel[m]]:RETurnloss:CALibration:VALues?
description:	Returns the the current calibration values 1. monitor diode reference power 2. return loss diode reference power 3. monitor diode parasitics power 4. return loss diode parasitics power.
parameters:	Returns power values in W
response:	none
example	sens1:ret:cal:val
affects:	All return loss modules

command:	:SENSe[n]:[CHANnel[m]]:RETUrnloss:CORRection:FPDelta[l]
syntax:	:SENSe[n]:[CHANnel[m]]:RETUrnloss:CORRection:FPDelta[l]<wsp><value>[dB]
description:	Sets the front panel delta, that is, the loss correction value, for example, due to the front panel connector. Twice this value is added to the measured Return Loss.
NOTE	Use [l] to set the front panel delta for an external source or the upper or lower wavelength laser source of a dual return loss module. An external laser source is denoted by 0. 0 is the default value of [l]. A lower wavelength source is denoted by 1. An upper wavelength source is denoted by 2.
parameters:	Sets the front panel delta as a float value in dB
response:	none
example	sens1:ret:cal:corr:fpd 0.08DB
affects:	All return loss modules

command:	:SENSe[n]:[CHANnel[m]]:RETUrnloss:CORRection:FPDelta[l]?
syntax:	:SENSe[n]:[CHANnel[m]]:RETUrnloss:CORRection:FPDelta[l]?
description:	Returns the front panel delta, that is, the loss correction value, for example, due to the front panel connector. Twice this value is added to the measured Return Loss.
NOTE	Use [l] to query the front panel delta for an external source or the upper or lower wavelength laser source of a dual return loss module. An external laser source is denoted by 0. 0 is the default value. A lower wavelength source is denoted by 1. An upper wavelength source is denoted by 2.
parameters:	Returns the front panel delta as a float value in dB
response:	none
example	sens1:ret:cal:corr:fpd? → +8.00000000E-002<END>
affects:	All return loss modules

command:	:SENSe[n]:[CHANnel[m]]:RETurnloss:CORRection:REFLectance[l]
syntax:	:SENSe[n]:[CHANnel[m]]:RETurnloss:CORRection:REFLectance[l]<wsp><value>[dB]
description:	Sets the Return Loss Reference, the return loss value of your reference reflector. For example, the Agilent 81000BR reference reflector provides an accurate and stable 0.18 dB reference.
NOTE	Use [l] to set the return loss value of your reference reflector for an external source or the upper or lower wavelength laser source of a dual return loss module. An external laser source is denoted by 0. 0 is the default value of [l]. A lower wavelength source is denoted by 1. An upper wavelength source is denoted by 2.
parameters:	Sets the Return Loss Reference as a float value in dB
response:	none
example	sens1:ret:cal:corr:refl 0.18DB
affects:	All return loss modules

command:	:SENSe[n]:[CHANnel[m]]:RETurnloss:CORRection:REFLectance[l]?
syntax:	:SENSe[n]:[CHANnel[m]]:RETurnloss:CORRection:REFLectance[l]?
description:	Returns the Return Loss Reference, the return loss value of your reference reflector. For example, the Agilent 81000BR reference reflector provides an accurate and stable 0.18 dB reference.
NOTE	Use [l] to query the return loss value of your reference reflector for an external source or the upper or lower wavelength laser source of a dual return loss module. An external laser source is denoted by 0. 0 is the default value of [l]. A lower wavelength source is denoted by 1. An upper wavelength source is denoted by 2.
parameters:	none
response:	Returns the Return Loss Reference as a float value in dB
example	sens1:ret:cal:corr:refl? → +1.80000000E-001<END>
affects:	All return loss modules

Signal Generation – The SOURce Subsystem

The SOURce subsystem allows you to control a laser source module, DFB source module, tunable laser module, or a return loss module that has an internal source.

command:	:OUTPut[<i>n</i>][:CHANnel[<i>m</i>]:CONNection
syntax:	OUTPut[<i>n</i>][:CHANnel[<i>m</i>]:CONNection<wsp>MOD VPP
description:	Sets the analog output parameter.
parameters:	MOD: The modulation frequency modulates the analog output. VPP: Output Voltage is proportional to optical power.
response:	none
example:	outp0:conn mod
affects:	All tunable laser modules with BNC ouput connector

command:	:OUTPut[<i>n</i>][:CHANnel[<i>m</i>]:CONNection?
syntax:	OUTPut[<i>n</i>][:CHANnel[<i>m</i>]:CONNection?
description:	Returns the analog output parameter.
parameters:	none
response:	MOD: The modulation frequency modulates the analog output. VPP: Output Voltage is proportional to optical power.
example:	outp0:conn? → MOD<END>
affects:	All tunable laser modules with BNC ouput connector

command:	:OUTPut[<i>n</i>][:CHANnel[<i>m</i>]:PATH
syntax:	:OUTPut[<i>n</i>][:CHANnel[<i>m</i>]:PATH<wsp><path>
description:	Sets the regulated path.
parameters:	HIGHpower: The High Power output is regulated. LOWsSe: The Low SSE output is regulated. BHRegulated: <u>B</u> oth outputs are active but only the <u>H</u> igh Power output is <u>R</u> egulated. BLRegulated: <u>B</u> oth outputs are active but only the <u>L</u> ow SSE output is <u>R</u> egulated.
response:	none
example:	output0:path high
affects:	Tunable laser modules with two outputs.

command:	:OUTPut[n][:CHANnel[m]:PATH?
syntax:	:OUTPut[n][:CHANnel[m]:PATH?
description:	Returns the regulated path.
parameters:	none
response:	HIGH: The High Power output is regulated. LOWS: The Low SSE output is regulated. BHR: <u>B</u> oth outputs are active but only the <u>H</u> igh Power output is <u>R</u> egulated. BLR: <u>B</u> oth outputs are active but only the <u>L</u> ow SSE output is <u>R</u> egulated.
example:	output0:path? → HIGH<END>
affects:	Tunable laser modules with two outputs.

command:	:OUTPut[n][:CHANnel[m][:STATe]
syntax:	:OUTPut[n][:CHANnel[m][:STATe]<wsp>OFF ON 0 1
description:	Switches the laser current off and on. The laser emits light only when the current is on. Set the state to OFF or 0 to switch the laser current off. Set the state to ON or 1 to switch the laser current on. The default is for the laser current to be off.
NOTE	For attenuator output see page 156
parameters:	0 or OFF: switch laser current off 1 or ON: switch laser current on
response:	none
example:	outp 1
affects:	All laser sources, DFB sources, tunable laser modules and return loss modules with an internal source

command:	:OUTPut[n][:CHANnel[m][:STATe]?
syntax:	:OUTPut[n][:CHANnel[m][:STATe]?
description:	Queries the current state of the laser current.
NOTE	For attenuator output see page 156
parameters:	none
response:	A <i>boolean</i> value: 0 – laser current off 1 – laser current on
example:	outp? → 1<END>
affects:	All laser sources, DFB sources, tunable laser modules and return loss modules with an internal source

command:	[[:SOURce[n]][:CHANnel[m]]:AM[:INTernal]:FREQuency[<i>l</i>]
syntax:	[[:SOURce[n]][:CHANnel[m]]:AM[:INTernal]:FREQuency[<i>l</i>]<wsp><frequency> [THZ GHZ MHZ KHZ HZ]
description:	Sets the frequency of the amplitude modulation of the laser output.
parameters:	The frequency as a <i>float</i> value in Hz. Also allowed are: MIN: minimum programmable value MAX: maximum programmable value DEF: This is not the preset (*RST) default value but is half the sum of, the minimum programmable value and the maximum programmable value The default units are HZ, although KHZ, MHZ, GHZ, and THZ can also be specified. The resolution of the frequency is always 1 Hz.
NOTE	Use [<i>l</i>] to set the modulation frequency of the upper or lower wavelength laser source of a dual-wavelength laser source or a return loss module with an internal dual-wavelength laser source. The default value of [<i>l</i>] is 1, the lower wavelength source. The upper wavelength source is denoted by 2.
response:	none
example:	sour2:am:freq 270hz
affects:	All laser sources, DFB sources, and tunable laser modules

command:	[[:SOURce[n]][:CHANnel[m]]:AM[:INTernal]:FREQuency[<i>l</i>]?
syntax:	[[:SOURce[n]][:CHANnel[m]]:AM[:INTernal]:FREQuency[<i>l</i>]? [MIN DEF MAX]
description:	Returns the frequency of the amplitude modulation as a <i>float</i> value in Hertz.
parameters:	MIN: minimum modulation frequency MAX: maximum modulation frequency DEF: This is not the preset (*RST) default value but is half the sum of, the minimum modulation frequency and the maximum modulation frequency.
NOTE	Use [<i>l</i>] to query the modulation frequency of the upper or lower wavelength laser source of a dual-wavelength laser source or a return loss module with an internal dual-wavelength laser source. The default value of [<i>l</i>] is 1, the lower wavelength source. The upper wavelength source is denoted by 2.
response:	modulation frequency relevant to the current value or specified parameter (if MIN, MAX, or DEF is chosen as a parameter).
example:	sour2:am:freq? min → +2.00000000E+002<END>
affects:	All laser sources, DFB sources, and tunable laser modules

command:	<code>[[:SOURce[n]][:CHANnel[m]]:AM:SOURce[l]</code>
syntax:	<code>[[:SOURce[n]][:CHANnel[m]]:AM:SOURce[l]<wsp> INT INT1 INT2 COHC AEXT EXT DEXT WVLL BACK 0 1 2 3 5 6</code>
description:	Selects the type or source of the modulation of the laser output.
parameters:	0, INT1, or INTernal: internal digital modulation 1, COHCtrl, or INT2: coherence control 2, AEXTernal, or EXT: external analog modulation 3 or DEXTernal: external digital modulation 5 or WVLLocking: wavelength locking 6 or BACKplane: external digital modulation using Input Trigger Connector
NOTE	Use [l] to set the modulation source of the upper or lower wavelength laser source of a dual-wavelength laser source or a return loss module with an internal dual-wavelength laser source. The default value of [l] is 1, the lower wavelength source. The upper wavelength source is denoted by 2.
response:	none
example:	<code>sour2:am:sour int</code>
affects:	All laser sources, DFB sources, and tunable laser modules can use internal digital modulation; as can return loss modules containing an internal source. DFB source and tunable laser modules can use coherence control. Other modulation modes are only available with tunable laser modules.

command:	<code>[[:SOURce[n]][:CHANnel[m]]:AM:SOURce[l]?</code>
syntax:	<code>[[:SOURce[n]][:CHANnel[m]]:AM:SOURce[l]?</code>
description:	Returns the type or source of the modulation of the laser output.
parameters:	none
NOTE	Use [l] to query the modulation source of the upper or lower wavelength laser source of a dual-wavelength laser source or a return loss module with an internal dual-wavelength laser source. The default value of [l] is 1, the lower wavelength source. The upper wavelength source is denoted by 2.
response:	0: internal digital modulation 1: coherence control 2: external analog modulation 3: external digital modulation 5: wavelength locking 6: external digital modulation using Input Trigger Connector
example:	<code>sour2:am:sour? → +0<END></code>
affects:	All laser sources, DFB sources, and tunable laser modules can use internal digital modulation; as can return loss modules containing an internal source. DFB source and tunable laser modules can use coherence control. All other modulation modes are only available with tunable laser modules.

command:	[[:SOURce[n]][:CHANnel[m]]:AM:STATe[<i>I</i>]
syntax:	[[:SOURce[n]][:CHANnel[m]]:AM:STATe[<i>I</i>]<wsp> OFF ON 0 1
description:	Enables and disables amplitude modulation of the laser output.
parameters:	A <i>boolean</i> value: OFF or 0: amplitude modulation disabled (default) ON or 1: amplitude modulation enabled.
NOTE	Use [<i>I</i>] to enable/disable amplitude modulation for the upper or lower wavelength laser source of a dual-wavelength laser source or a return loss module with an internal dual-wavelength laser source. The default value of [<i>I</i>] is 1, the lower wavelength source. The upper wavelength source is denoted by 2.
NOTE	When the internal modulation is selected, the Modulation Output on the front panel outputs a version of the modulating signal that has the same frequency and phase as the modulating signal, but has a fixed, TTL-level amplitude. You can use this to synchronize your external measuring equipment to your instrument. To allow for your possible synchronization requirements, there are two ways in which the signal can be output. Either the signal is combined with the laser-ready signal, so that the output is kept low when there is no optical signal being output (for example, while the laser is settling after a change of wavelength). Or the modulation signal is output all the time. This is set by the :SOURCE:MODOUT command (see “[[:SOURce[n]][:CHANnel[m]]:MODout” on page 121).
NOTE	When you enable lambda logging, see “[[:SOURce[n]][:CHANnel[m]]:WAVelength:SWEEp:LLOGging” on page 140, and modulation simultaneously, a sweep cannot be started, see “[[:SOURce[n]][:CHANnel[m]]:WAVelength:SWEEp:[STATe]” on page 145.
response:	none
example:	sour2:am:stat 0
affects:	All laser sources, DFB sources, tunable laser modules, and return loss modules containing an internal source.

command:	[[:SOURce[n]][:CHANnel[m]]:AM:STATe[<i>I</i>]?
syntax:	[[:SOURce[n]][:CHANnel[m]]:AM:STATe[<i>I</i>]?
description:	Returns the current state of amplitude modulation.
NOTE	Use [<i>I</i>] to query the current state of modulation of the upper or lower wavelength laser source of a dual-wavelength laser source or a return loss module with an internal dual-wavelength laser source. The default value of [<i>I</i>] is 1, the lower wavelength source. The upper wavelength source is denoted by 2.
parameters:	none
response:	A <i>boolean</i> value: 0: modulation is disabled 1: modulation is enabled
example:	sour2:am:stat? → 0<END>
affects:	All laser sources, DFB sources, tunable laser modules, and return loss modules containing an internal source.

command:	[[:SOURce[n]][:CHANnel[m]]:AM:COHCtrl:COHLevel[l]
syntax:	[[:SOURce[n]][:CHANnel[m]]:AM:COHCtrl:COHLevel[l]<wsp><value>[MIN MAX DEF]
description:	Sets the level of coherence, when using coherence control, on an arbitrary scale from 1 to 99.98%. A 100% coherence level corresponds to maximum coherence length and minimum linewidth. The coherence level required for a specific linewidth and coherence length can vary between modules.
parameters:	The excursion level as a percentage of its maximum value. Also allowed: MIN: minimum programmable value (0%) MAX: maximum programmable value (100%) DEF: default preset (*RST) value.
response:	none
example:	source2:am:cohc 50
affects:	DFB sources and Agilent 81980A, 81940A, 81989A, 81949A

command:	[[:SOURce[n]][:CHANnel[m]]:AM:COHCtrl:COHLevel[l]?
syntax:	[[:SOURce[n]][:CHANnel[m]]:AM:COHCtrl:COHLevel[l]<wsp><value>?[MIN MAX DEF]
description:	Queries the current level of coherence, when using Coherence Control. Coherence is expressed on an arbitrary scale from 1 to 99.98%. A 100% coherence level corresponds to maximum coherence length and minimum linewidth.
parameters:	Optional MIN: returns the minimum programmable value (0%) MAX: returns the maximum programmable value (100%) DEF: returns the default preset (*RST) value.
response:	Returns the currently set excursion level as a percentage between 0 and 99.98
example:	source2:am:cohc? → 50<END>
affects:	DFB sources and Agilent 81980A, 81940A, 81989A, 81949A

command:	[[:SOURce[n]][:CHANnel[m]]:FM:SOURce[l]
syntax:	[[:SOURce[n]][:CHANnel[m]]:FM:SOURce[l]<wsp>SBSCtrl 0
description:	Selects the type of the frequency modulation of the laser output. Currently, only parameter strings that select SBS Control are valid. Enable frequency modulation before issuing this command. Refer to “[[:SOURce[n]][:CHANnel[m]]:FM:STAtel[l]” on page 119.
parameters:	0, SBSCtrl Simulated Brillouin Scattering NOTE SBSCtrl (Simulated Brillouin Scattering) Control modulation suppresses SBS effects within high-power measurement setups.
response:	none
example:	sour2:fm:sour SBSC
affects:	Agilent 81980A, 81940A, 81989A, 81949A compact tunable lasers.

command:	[[:SOURce[n]][:CHANnel[m]]:FM:SOURce[/?]
syntax:	[[:SOURce[n]][:CHANnel[m]]:FM:SOURce[/?]
description:	Queries the type of frequency modulation currently set. Currently, only SBS Control is available.
parameters:	none
response:	0 SBS Control
example:	sour2:fm:sour? → +0<END>
affects:	Agilent 81980A, 81940A, 81989A, 81949A compact tunable lasers.

command:	[[:SOURce[n]][:CHANnel[m]]:FM:STATe[/?]
syntax:	[[:SOURce[n]][:CHANnel[m]]:FM:STATe[/?]<wsp>OFF ON 0 1
description:	Enables and disables frequency modulation of the laser output.
parameters:	A <i>boolean</i> value: OFF or 0: disable frequency modulation ON or 1: enable frequency modulation.
response:	none
example:	sour2:fm:state 1
affects:	Agilent 81980A, 81940A, 81989A, 81949A compact tunable lasers.

command:	[[:SOURce[n]][:CHANnel[m]]:FM:STATe[/?]
syntax:	[[:SOURce[n]][:CHANnel[m]]:FM:STATe[/?]
description:	Queries the current state of frequency modulation of the laser output.
parameters:	none
response:	A <i>boolean</i> value: 0: frequency modulation is disabled 1: frequency modulation is enabled.
example:	sour2:fm:state? → +1<END>
affects:	Agilent 81980A, 81940A, 81989A, 81949A compact tunable lasers.

command:	[[:SOURce[n]][:CHANnel[m]]:FM:SBSCtrl:FREQuency[<i>f</i>]
syntax:	[[:SOURce[n]][:CHANnel[m]]:FM:SBSCtrl:FREQuency[<i>f</i>]<wsp><frequency> [MHZ KHZ HZ MIN MAX DEF]
description:	Sets the frequency of the SBS Control modulation. Enable frequency modulation before issuing this command. Refer to “[:SOURce[n]][:CHANnel[m]]:FM:SOURce[<i>f</i>]” on page 118 and “[:SOURce[n]][:CHANnel[m]]:FM:STATe[<i>f</i>]” on page 119.
parameters:	The modulation frequency as a <i>float</i> value. The default units are HZ, although KHZ, MHZ, GHZ and THZ can also be specified. Also allowed are: MIN: minimum programmable value MAX: maximum programmable value DEF: default preset (*RST) value.
response:	none
example:	sour2:fm:sbsc:freq 4000Hz
affects:	Agilent 81980A, 81940A, 81989A, 81949A compact tunable lasers.

command:	[[:SOURce[n]][:CHANnel[m]]:FM:SBSCtrl:FREQuency[<i>f</i>?]
syntax:	[[:SOURce[n]][:CHANnel[m]]:FM:SBSCtrl:FREQuency[<i>f</i> ?<wsp>[MIN MAX DEF]
description:	Queries the currently set frequency of the SBS Control modulation.
parameters:	Optional MIN: returns the minimum programmable value MAX: returns the maximum programmable value DEF: returns the default preset (*RST) value.
response:	The modulation frequency in Hz as a <i>float</i> value
example:	sour2:fm:freq? → +4.00000E+03<END>
affects:	Agilent 81980A, 81940A, 81989A, 81949A compact tunable lasers.

command:	[[:SOURce[n]][:CHANnel[m]]:FM:SBSCtrl:LEVel[<i>f</i>]
syntax:	[[:SOURce[n]][:CHANnel[m]]:FM:SBSCtrl:LEVel[<i>f</i>]<wsp>[MIN MAX DEF]
description:	Sets the excursion of the SBS Control frequency modulation to a percentage of its maximum value.
parameters:	The excursion level as a percentage of its maximum value. Also allowed: MIN: minimum programmable value (0%) MAX: maximum programmable value (100%) DEF: default preset (*RST) value.
response:	none
example:	sour2:fm:sbsc:lev 80
affects:	Agilent 81980A, 81940A, 81989A, 81949A compact tunable lasers.

command:	[[:SOURce[n]][:CHANnel[m]]:FM:SBSCtrl:Level[l]?]
syntax:	[[:SOURce[n]][:CHANnel[m]]:FM:SBSCtrl:LEVel[l]?<wsp>[MIN MAX DEF]
description:	Queries the currently set excursion level of the SBS Control frequency modulation.
parameters:	Optional MIN: returns the minimum programmable value (0%) MAX: returns the maximum programmable value (100%) DEF: returns the default preset (*RST) value.
response:	Returns the currently set excursion level as a percentage of its maximum value.
example:	sour2:fm:sbsc:lev? → +8.000E+01<END>
affects:	Agilent 81980A, 81940A, 81989A, 81949A compact tunable lasers.

command:	[[:SOURce[n]][:CHANnel[m]]:MODout]
syntax:	[[:SOURce[n]][:CHANnel[m]]:MODout<wsp>FRQ FRQRDY 0 1]
description:	Sets the modulation output mode of the BNC connector on the front panel of tunable laser modules.
parameters:	FRQ or 0: modulation signal is output all the time FRQRDY or 1: modulation is combined with the laser-ready signal. In this case, the output is kept low when no optical signal is output (for example, while the laser is settling after a change of wavelength).
response:	none
example:	sour0:mod 0
affects:	All tunable laser sources with BNC output connector.

command:	[[:SOURce[n]][:CHANnel[m]]:MODout?]
syntax:	[[:SOURce[n]][:CHANnel[m]]:MODout?]
description:	Queries the modulation output mode of the BNC connector on the front panel of tunable laser modules.
parameters:	none
response:	0: modulation signal is output all the time 1: modulation is combined with the laser-ready signal. In this case, the output is kept low when no optical signal is output (for example, while the laser is settling after a change of wavelength).
example:	sour0:mod? → 0<END>
affects:	All tunable laser sources with BNC output connector.

command:	[[:SOURce[n]][:CHANnel[m]]:POWer:ATTenuation[<i>I</i>]
syntax:	[[:SOURce[n]][:CHANnel[m]]:POWer:ATTenuation[<i>I</i>]<wsp><value>[DB MDB]
description:	Sets the level of attenuation.
parameters:	Any value in the specified range (see the specifications in the appropriate <i>User's Guide</i>). Also allowed (for tunable laser modules only) are: MIN: minimum programmable value MAX: maximum programmable value DEF: This is not the preset (*RST) default value but is half the sum of, the minimum programmable value and the maximum programmable value
NOTE	Use [<i>I</i>] to set the attenuation level of the upper or lower wavelength laser source of a dual-wavelength laser source or of a return loss module with an internal dual-wavelength laser source. The default value of [<i>I</i>] is 1, the lower wavelength source. The upper wavelength source is denoted by 2.
NOTE	Tunable laser modules with in-built optical attenuators need to be in Manual Attenuation Mode (see "[[:SOURce[n]][:CHANnel[m]]:POWer:ATTenuation[<i>I</i>]:AUTO" on page 123) for this value to have an affect. The output power is a combination of this value and the laser output power (see "[[:SOURce[n]][:CHANnel[m]]:POWer[:LEVel][:IMMEDIATE][:AMPLitude[<i>I</i>]]" on page 124).
NOTE	In this respect, this command does not conform to the SCPI standard. The SCPI standard requires that entering an explicit value for the attenuation switches the attenuation mode OFF. The default units are dB .
response:	none
example:	sour0:pow:att 22.32db
affects:	All tunable laser modules with an built-in optical attenuator, and all laser source modules.

command:	[[:SOURce[n]][:CHANnel[m]]:POWer:ATTenuation[<i>I</i>]?
syntax:	[[:SOURce[n]][:CHANnel[m]]:POWer:ATTenuation[<i>I</i>]?[MIN DEF MAX]
description:	Queries the attenuation level. When using a tunable laser module with a built-in optical attenuator, the value returned applies only to the attenuation mode (see "[[:SOURce[n]][:CHANnel[m]]:POWer:ATTenuation[<i>I</i>]:AUTO" on page 123).
NOTE	Use [<i>I</i>] to query the attenuation level of the upper or lower wavelength laser source of a dual-wavelength laser source or of a return loss module with an internal dual-wavelength laser source. The default value of [<i>I</i>] is 1, the lower wavelength source. The upper wavelength source is denoted by 2.
parameters:	Also allowed (for tunable laser modules only) are: MIN: minimum amplitude level MAX: maximum amplitude level DEF: This is not the preset (*RST) default value but is half the sum of, the minimum amplitude level and the maximum amplitude level
response:	attenuation level relevant to the current value or specified parameter (if MIN, MAX, or DEF are chosen as a parameter).
example:	sour0:pow:att? def → +3.1000000+E001<END>
affects:	All tunable laser modules with an in-built optical attenuator, and all laser source modules.

command:	[[:SOURce[n]][:CHANnel[m]]:POWer:ATTenuation[/]:AUTO
syntax:	[[:SOURce[n]][:CHANnel[m]]:POWer:ATTenuation[/]:AUTO<wsp>OFF ON 0 1
description:	Selects Automatic or Manual Attenuation Mode. In Automatic Attenuation Mode, you specify the output power. In Manual Attenuation Mode, you must specify both the laser output power, and the attenuation level.
parameters:	OFF or 0: Attenuation Mode ON or 1: Power Mode
response:	none
example:	sour0:pow:att:auto 1
affects:	All tunable laser sources with a built-in optical attenuator.

command:	[[:SOURce[n]][:CHANnel[m]]:POWer:ATTenuation[/]:AUTO?
syntax:	[[:SOURce[n]][:CHANnel[m]]:POWer:ATTenuation[/]:AUTO?
description:	Queries whether the instrument is in Automatic or Manual Attenuation Mode.
parameters:	none
response:	0: Manual Attenuation Mode 1: Automatic Attenuation Mode
example:	sour0:pow:att:auto? → 1<END>
affects:	All tunable laser modules with a built-in optical attenuator.

command:	[[:SOURce[n]][:CHANnel[m]]:POWer:ATTenuation[/]:DARK
syntax:	[[:SOURce[n]][:CHANnel[m]]:POWer:ATTenuation[/]:DARK<wsp>OFF ON 0 1
description:	Sets or unsets the attenuator to 'dark' position. Dark position blocks all light from the laser. You can use this as an alternative to disabling the laser, the advantage of doing this is that you avoid the laser rise time. This command is available in Attenuation Mode Only.
parameters:	OFF or 0: Unsets dark position ON or 1: Sets dark position
response:	none
example:	sour0:pow:att:dark 1
affects:	All tunable laser modules with a built-in optical attenuator.

command:	[[:SOURce[n]][:CHANnel[m]]:POWer:ATTenuation[l]:DARK?
syntax:	[[:SOURce[n]][:CHANnel[m]]:POWer:ATTenuation[l]:DARK?
description:	Queries whether the attenuator is set to 'dark' position (where all light is blocked by the laser).
parameters:	none
response:	0: dark position not set 1: dark position set
example:	sour0:pow:att:dark? → 1<END>
affects:	All tunable laser modules with a built-in optical attenuator.

command:	[[:SOURce[n]][:CHANnel[m]]:POWer:LEVel[:IMMEDIATE][:AMPLitude[l]]
syntax:	[[:SOURce[n]][:CHANnel[m]]:POWer:LEVel[:IMMEDIATE][:AMPLitude[l]]<wsp><value> [PW NW UW MW Watt DBM]
description:	Sets the power of the laser output.
NOTE	If an optical attenuator is installed, the power value returned is dependent on whether you are using power or attenuation mode (see "[[:SOURce[n]][:CHANnel[m]]:POWer:ATTenuation[l]:AUTO" on page 123). If you are using power mode, the value returned is the output power. If you are using attenuation mode, the value returned is the laser output power, and you must also use the attenuation value to calculate the output power (see "[[:SOURce[n]][:CHANnel[m]]:POWer:ATTenuation[l]" on page 122).
NOTE	The values for the output power that you set in the Power Mode, and the laser output power that you set in the Attenuation Mode, are stored and used independently. The instrument may not be able to output a signal with the maximum programmable power, it will output a signal with the maximum power. Use the "[[:SOURce[n]][:CHANnel[m]]:POWer:LEVel[:IMMEDIATE][:AMPLitude[l]]?" on page 125 to query the power being output. The default units are DBM or W, depending on the unit selected using the following command: "[[:SOURce[n]][:CHANnel[m]]:POWer:UNIT" on page 127.
parameters:	Any value in the specified range (see the appropriate <i>User's Guide</i>). Also allowed are: MIN: minimum programmable value MAX: maximum programmable value DEF: This is not the preset (*RST) default value, but is the maximum programmable level
NOTE	Use [l] to set the amplitude level of the output power of the upper or lower wavelength laser source of a dual-wavelength laser source or a return loss module with an internal dual-wavelength laser source. The default value of [l] is 1, the lower wavelength source. The upper wavelength source is denoted by 2.
response:	none
example:	sour2:pow 23uW
affects:	All tunable laser and DFB source modules

command:	<code>[[:SOURce[n]][:CHANnel[m]]:POWer[:LEVel][:IMMediate]][:AMPLitude[<i>l</i>]]?</code>
syntax:	<code>[[:SOURce[n]][:CHANnel[m]]:POWer[:LEVel][:IMMediate]][:AMPLitude[<i>l</i>]]?<wsp> [MIN DEF MAX]</code>
description:	Returns the amplitude level of the output power. The value returned is the actual amplitude that is output, which may be different from the value set for the output. If these two figures are not the same, it is indicated in the :STATus:OPERation register.
NOTE	If an optical attenuator is installed, the power value returned is dependent on whether you are using power or attenuation mode (see “[:SOURce[n]][:CHANnel[m]]:POWer:ATTenuation[<i>l</i>]:AUTO” on page 123). If you are using power mode, the value returned is the output power. If you are using attenuation mode, the value returned is the laser output power, and you must also use the attenuation value to calculate the output power (see “[:SOURce[n]][:CHANnel[m]]:POWer:ATTenuation[<i>l</i>]” on page 122). The values for the output power that you set in the Power Mode, and the laser output power that you set in the Attenuation Mode, are stored and used independently.
parameters:	Also allowed MIN: minimum amplitude level (for tunable laser modules only) are: MAX: maximum amplitude level DEF: This is not the preset (*RST) default value but is half the sum of, the minimum amplitude level and the maximum amplitude level
NOTE	Use [<i>l</i>] to query the amplitude level of the output power of the upper or lower wavelength laser source of a dual-wavelength laser source or a return loss module with an internal dual-wavelength laser source. The default value of [<i>l</i>] is 1, the lower wavelength source. The upper wavelength source is denoted by 2.
response:	Amplitude level relevant to the current value or specified parameter (if MIN, MAX, or DEF are chosen as a parameter).
example:	<code>sour2:pow? → +8.00000000E-004<END></code>
affects:	All laser sources, DFB sources, and tunable laser modules and return loss modules with an internal source

command:	<code>[[:SOURce[n]][:CHANnel[m]]:POWer[:LEVel]:RISetime[<i>l</i>]</code>
syntax:	<code>[[:SOURce[n]][:CHANnel[m]]:POWer[:LEVel]:RISetime[<i>l</i>]<wsp><value>[NS US MS S]</code>
description:	Sets the laser rise time of the chosen source.
parameters:	Any value in the specified range (see the appropriate <i>User's Guide</i>). Also allowed are: <ul style="list-style-type: none"> MIN: minimum programmable value MAX: maximum programmable value DEF: This is not the preset (*RST) default value but is half the sum of, the minimum programmable level and the maximum programmable level
NOTE	Use [<i>l</i>] to set the risetime of the upper or lower wavelength laser source of a dual-wavelength laser source or a return loss module with an internal dual-wavelength laser source. The default value of [<i>l</i>] is 1, the lower wavelength source. The upper wavelength source is denoted by 2.
response:	none
example:	<code>sour2:pow:ris 10ns</code>
affects:	All laser sources, DFB sources, and tunable laser modules and return loss modules with an internal source

command:	<code>[[:SOURce[n]][:CHANnel[m]]:POWer[:LEVel]:RISetime[<i>l</i>?]</code>
syntax:	<code>[[:SOURce[n]][:CHANnel[m]]:POWer[:LEVel]:RISetime[<i>l</i>?<wsp>[MIN DEF MAX]</code>
description:	Returns the laser rise time of the chosen source.
parameters:	Also allowed are: <ul style="list-style-type: none"> MIN: minimum programmable value MAX: maximum programmable value DEF: This is not the preset (*RST) default value but is half the sum of, the minimum programmable level and the maximum programmable level
NOTE	Use [<i>l</i>] to query the risetime of the upper or lower wavelength laser source of a dual-wavelength laser source or a return loss module with an internal dual-wavelength laser source. The default value of [<i>l</i>] is 1, the lower wavelength source. The upper wavelength source is denoted by 2.
response:	The rise time as a float value in seconds.
example:	<code>sour2:pow:ris? → +1.00000000E-009<END></code>
affects:	All laser sources, DFB sources, and tunable laser modules and return loss modules with an internal source

command:	[[:SOURce[n]][:CHANnel[m]]:POWer:STATe
syntax:	[[:SOURce[n]][:CHANnel[m]]:POWer:STATe<wsp><boolean>
description:	Switches the laser of the chosen source on or off.
parameters:	A <i>boolean</i> value: 0: Laser Off 1: Laser On
response:	none
example:	sour2:pow:stat 1
affects:	All laser source, DFB source, and tunable laser modules and return loss modules with an internal source

command:	[[:SOURce[n]][:CHANnel[m]]:POWer:STATe?
syntax:	[[:SOURce[n]][:CHANnel[m]]:POWer:STATe?
description:	Queries the laser state of the chosen source.
parameters:	none
response:	A <i>boolean</i> value: 0: Laser Off 1: Laser On
example:	sour2:pow:stat? → 1<END>
affects:	All laser source, DFB source, and tunable laser modules and return loss modules with an internal source

command:	[[:SOURce[n]][:CHANnel[m]]:POWer:UNIT
syntax:	[[:SOURce[n]][:CHANnel[m]]:POWer:UNIT<wsp>DBM 0 Watt 1
description:	Sets the power units
parameters:	0 or DBM: dBm (default) 1 or W: Watts
response:	none
example:	sour2:pow:unit w
affects:	All tunable laser and DFB source modules

command:	[[:SOURce[n]][:CHANnel[m]]:POWer:UNIT?
syntax:	[[:SOURce[n]][:CHANnel[m]]:POWer:UNIT?
description:	Return the current power units
parameters:	0: dBm 1: Watts
response:	none
example:	sour2:pow:unit? → +0<END>
affects:	All tunable laser and DFB source modules

command:	[:SOURce[n]][:CHANnel[m]]:POWer:WAVelength
syntax:	[:SOURce[n]][:CHANnel[m]]:POWer:WAVelength[<wsp> EXTernal LOWer UPPer BOTH 0 1 2 3]
NOTE	For compatibility reasons, WAVelength may be replaced with WAVE.
description:	Sets the wavelength source for a dual-wavelength laser source.
parameters:	EXTernal: or 0 External LOWer: or 1 The lower wavelength source UPPer: or 2 The upper wavelength source BOTH: or 3 Both wavelength sources
response:	none
example:	sour2:pow:wav upp
affects:	All dual-wavelength laser source modules and return loss modules with two internal sources

command:	[:SOURce[n]][:CHANnel[m]]:POWer:WAVelength?
syntax:	[:SOURce[n]][:CHANnel[m]]:POWer:WAVelength?
NOTE	For compatibility reasons, WAVelength may be replaced with WAVE.
description:	Returns the wavelength source for a dual-wavelength laser source.
parameters:	none
response:	LOW The lower wavelength source UPP The upper wavelength source BOTH Both wavelength sources
example:	sour2:pow:wav? → LOW<END>
affects:	All dual-wavelength laser source modules and return loss modules with two internal sources

command:	[[:SOURce[n]][:CHANnel[m]]:READout:DATA?
syntax:	[[:SOURce[n]][:CHANnel[m]]:READout:DATA?
description:	Returns the data as a binary stream from either a lambda logging operation or the maximum power the laser can produce at each wavelength.
parameters:	<p>LLOGging: Returns a binary stream that contains each wavelength step of the lambda logging operation, see “[:SOURce[n]][:CHANnel[m]]:WAVelength:SWEEp:LLOGging” on page 140. Each binary block is an 8-byte long double in Intel byte order.</p> <p>PMAX: Returns a binary stream that contains the maximum power the laser can produce at each wavelength. Each binary block is a 8-byte long double (the wavelength value) followed by a 4-byte long float (the power value). The stream is in Intel byte order.</p>
response:	A binary stream in Intel byte order.
example:	sour2:read:data? llog → <i>the data as a binary stream</i>
affects:	All tunable laser and DFB source modules

command:	[[:SOURce[n]][:CHANnel[m]]:READout:DATA:BLOCK?
syntax:	[[:SOURce[n]][:CHANnel[m]]:READout:DATA:BLOCK?<wsp>LLOGging PMAX,<offset>,<# of data points>
description:	Returns a specified binary block from either a lambda logging operation, or maximum power at wavelength characteristic.
parameters:	<p>LLOGging: Returns the data block from lambda logging. The binary block is an 8-byte long double in Intel byte order.</p> <p>PMAX: Returns the data block from the power curve characteristic. Each binary block is a 8-byte long double (the wavelength value) followed by a 4-byte long float (the power value). The stream is in Intel byte order.</p> <p><offset> A zero based offset that specifies the index of the first value within the block to be transferred.</p> <p><# of data points> The number of points (not bytes!) in the transferred block.</p>
response:	A binary stream in Intel byte order.
example:	sour0:read:data:block? llog,100,20000 → <i>the data as a binary stream</i>
affects:	All tunable laser and DFB source modules

command:	[[:SOURce[n]][:CHANnel[m]]:READout:DATA:MAXBlocksize?
syntax:	[[:SOURce[n]][:CHANnel[m]]:READout:DATA:MAXBlocksize?
description:	Returns the maximum block size for a single GPIB transfer for lambda logging functions. If your application requires more data points please use SOURce[n]][:CHANnel[m]]:READout:DATA:BLOCK? instead of SOURce[n]][:CHANnel[m]]:READout:DATA?
parameters:	none
response:	The maximum number of data points (not bytes!) in the transferred block, as an <i>integer</i> value.
example:	sour0:read:data:maxb? → 120<END>
affects:	All tunable laser and DFB source modules

command:	[[:SOURce[n]][:CHANnel[m]]:READout:POINts?
syntax:	[[:SOURce[n]][:CHANnel[m]]:READout:POINts?<wsp>LLOGging PMAX
description:	Returns the number of datapoints that the [:SOURce[n]][:CHANnel[m]]:READout:DATA? command will return.
parameters:	<p>LLOGging: Returns the number of wavelength steps for a lambda logging operation, see “[:SOURce[n]][:CHANnel[m]]:WAVelength:SWEEp:LLOGging” on page 140.</p> <p>PMAX: Returns the number of datapoints (each datapoint contains a value for wavelength and power) the [:SOURce[n]][:CHANnel[m]]:READout:DATA? PMAX command will return, number of datapoints depends on the calibration data for your module.</p>
response:	The number of datapoints as an <i>integer</i> value.
example:	sour2:read:poin? pmax → 120<END>
affects:	All tunable laser and DFB source modules

command:	[[:SOURce[n]][:CHANnel[m]]:WAVelength[:CW[l]]:FIXED[l]]
syntax:	[[:SOURce[n]][:CHANnel[m]]:WAVelength[:CW[l]]:FIXED[l]<wsp><value> [PM NM UM MM M]
description:	Sets the absolute wavelength of the output.
parameters:	<p>Any wavelength in the specified range (see the specifications in the appropriate <i>User’s Guide</i>).</p> <p>The programmable range is larger than the range specified in the <i>User’s Guide</i>. The programmable range is set individually for each instrument when it is calibrated during production.</p> <p>Also allowed are: MIN: minimum wavelength value MAX: maximum wavelength value DEF: This is not the preset (*RST) default value but is half the sum of, the minimum wavelength value and the maximum wavelength value</p>
NOTE	Use [l] to set the upper or lower wavelength laser source of a dual-wavelength laser source. The default value of [l] is 1, the lower wavelength source. The upper wavelength source is denoted by 2.
response:	none
example:	sour2:wav 1550NM
affects:	All tunable laser and DFB source modules

command:	[:SOURce[n]][:CHANnel[m]]:WAVelength[:CW[l] :FIXED[l]]?	
syntax:	[:SOURce[n]][:CHANnel[m]]:WAVelength[:CW[l] :FIXED[l]]? [<wsp>[MIN DEF MAX]]	
description:	Returns the wavelength value in meters.	
parameters:	none	
	Also allowed, for tunable laser modules only, are	MIN: minimum wavelength MAX: maximum wavelength DEF: This is not the preset (*RST) default value but is half the sum of, the minimum wavelength value and the maximum wavelength value
	NOTE	Use [l] to query the upper or lower wavelength laser source of a dual-wavelength laser source. The default value of [l] is 1, the lower wavelength source. The upper wavelength source is denoted by 2.
response:	The wavelength as a <i>float</i> value in meters.	
example:	sour0:wav? → +1.5672030E-006<END>	Returns the current wavelength value for a tunable laser module.
	sour0:wav? min → +1.5500000E-006<END>	Returns minimum wavelength for a tunable laser module.
	sour2:wav:fixed2? → +1.61544494E-006<END>	Returns the wavelength value of the upper wavelength source of a dual-wavelength laser source.
affects:	All laser source, DFB source, and tunable laser modules and return loss modules with an internal source	

command:	[:SOURce[n]][:CHANnel[m]]:WAVelength:CORRection:ARA	
syntax:	[:SOURce[n]][:CHANnel[m]]:WAVelength:CORRection:ARA	
description:	Realigns the laser cavity.	
parameters:	none	
response:	none	
example:	sour0:wav:corr:ara	
affects:	All tunable laser modules except Agilent 81649A and Agilent 81689A/B	

command:	[[:SOURce[n]][:CHANnel[m]]:WAVelength:CORRection:ARA:ALL
syntax:	[[:SOURce[n]][:CHANnel[m]]:WAVelength:CORRection:ARA:ALL
description:	Realigns the laser cavity of every tunable laser source in a mainframe.
parameters:	none
response:	none
example:	sour0:wav:corr:ara:all
affects:	All tunable laser modules except Agilent 81649A and Agilent 81689A/B

command:	[[:SOURce[n]][:CHANnel[m]]:WAVelength:CORRection:AUTocalib
syntax:	[[:SOURce[n]][:CHANnel[m]]:WAVelength:CORRection:AUTocalib<wsp>ON (1) OFF (0)
description:	Sets the Auto Calibration feature On or OFF. Switching it OFF enables the TLS to operate for a long period without interruption from the "auto lambda zeroing" or settling. When Auto Calibration is disabled, it is possible to operate the TLS at a temperature that differs more than 4.4 K from the last Lambda Zeroing temperature. In this case, the accuracy and wavelength performance of the TLS can become less optimal due to temperature variation. The relevant accuracy class is indicated on the user interface when Auto Calibration is off.
parameters:	a boolean value: 1 or ON: enable Autocalibration 0 or OFF: disable Autocalibration
response:	none
example:	sour0:wav:corr:aut 0
affects:	All tunable laser modules except Agilent 81649A, 81689A/B and Agilent 81980A, 81940A, 81989A, 81949A.

command:	[[:SOURce[n]][:CHANnel[m]]:WAVelength:CORRection:AUTocalib?
syntax:	[[:SOURce[n]][:CHANnel[m]]:WAVelength:CORRection:AUTocalib?
description:	Returns whether Autocalibration is enabled or disabled
parameters:	none
response:	0 Autocalibration disabled 1 Autocalibration enabled
example:	sour0:wav:corr:aut? → 1
affects:	All tunable laser modules except Agilent 81649A, 81689A/B and Agilent 81980A, 81940A, 81989A, 81949A.

command:	[[:SOURce[n]][:CHANnel[m]]:WAVelength:CORRection:ZERO
syntax:	[[:SOURce[n]][:CHANnel[m]]:WAVelength:CORRection:ZERO
description:	Executes a wavelength zero.
parameters:	none
response:	none
example:	sour2:wav:corr:zero
affects:	All tunable laser modules except Agilent 81649A and Agilent 81689A/B

command:	[[:SOURce[n]][:CHANnel[m]]:WAVelength:CORRection:ZERO:ALL
syntax:	[[:SOURce[n]][:CHANnel[m]]:WAVelength:CORRection:ZERO:ALL
description:	Executes a wavelength zero on every tunable laser source in a mainframe.
parameters:	none
response:	none
example:	sour2:wav:corr:zero:all
affects:	All tunable laser modules except Agilent 81649A and Agilent 81689A/B

command:	[[:SOURce[n]][:CHANnel[m]]:WAVelength:CORRection:ZERO:TEMPerature:ACTual?
syntax:	[[:SOURce[n]][:CHANnel[m]]:WAVelength:CORRection:ZERO:TEMPerature:ACTual?
description:	Reports the current lambda zero temperature.
parameters:	none
response:	float value; temperature in °C
example:	sour0:wav:corr:zero:temp:act?
affects:	All tunable laser modules except Agilent 81649A, Agilent 81689A/B and 819xxA/B

command:	[[:SOURce[n]][:CHANnel[m]]:WAVelength:CORRection:ZERO:TEMPerature:DIFFerence?
syntax:	[[:SOURce[n]][:CHANnel[m]]:WAVelength:CORRection:ZERO:TEMPerature:DIFFerence?
description:	Reports the temperature difference required to trigger an auto lambda zero.
parameters:	none
response:	float value; temperature in °C
example:	sour0:wav:corr:zero:temp:diff?
affects:	All tunable laser modules except Agilent 81649A, Agilent 81689A/B and 819xxA/B

command:	[[:SOURce[n]][:CHANnel[m]]:WAVelength:CORRection:ZERO:TEMPerature:LASTzero?
syntax:	[[:SOURce[n]][:CHANnel[m]]:WAVelength:CORRection:ZERO:TEMPerature:LASTzero?
description:	Reports the temperature at which the last auto lamda zero took place.
parameters:	none
response:	float value; temperature in °C
example:	sour0:wav:corr:zero:temp:last?
affects:	All tunable laser modules except Agilent 81649A, Agilent 81689A/B and 819xxA/B

command:	[[:SOURce[n]][:CHANnel[m]]:WAVelength:CORRection:ZERO:AUTO
syntax:	[[:SOURce[n]][:CHANnel[m]]:WAVelength:CORRection:ZERO:AUTO
description:	Forces an auto lamda zero. This is quicker but a little less accurate than the equilavent manual process because some checks are omitted:
parameters:	none
response:	none
example:	sour0:wav:corr:zero:auto
affects:	All tunable laser modules except Agilent 81649A, Agilent 81689A/B and 819xxA/B

command:	[[:SOURce[n]][:CHANnel[m]]:WAVelength:FREQUency[l]
syntax:	[[:SOURce[n]][:CHANnel[m]]:WAVelength:FREQUency[l]<wsp><value> [THZ GHZ MHZ KHZ HZ]
description:	Sets the frequency difference used to calculate a relative wavelength. The output wavelength is made up of the reference wavelength and this frequency difference. The default units for frequency are Hertz. The output wavelength (λ) is set from the base wavelength (λ_0) and the frequency offset (df). The formula for calculating the output wavelength is: $\lambda = \frac{(c)}{((\lambda_0 df) + c)} \lambda_0$ <p>where c is the speed of light in a vacuum ($2.990 \times 10^8 \text{ ms}^{-1}$)</p> <p>NOTE Use [l] to set the frequency of the upper or lower wavelength laser source of a dual-wavelength laser source or a return loss module with an internal dual-wavelength laser source. The default value of [l] is 1, the lower wavelength source. The upper wavelength source is denoted by 2.</p>
parameters:	The frequency difference is a float value in Hz.
response:	none
example:	sour0:wav:freq -10THZ
affects:	All tunable laser sources

command:	[[:SOURce[n]][:CHANnel[m]]:WAVelength:FREQuency[1]?
syntax:	[[:SOURce[n]][:CHANnel[m]]:WAVelength:FREQuency[1]?
description:	Returns the frequency difference used to calculate a relative wavelength.
NOTE	Use [1] to query the frequency of the upper or lower wavelength laser source of a dual-wavelength laser source or a return loss module with an internal dual-wavelength laser source. The default value of [1] is 1, the lower wavelength source. The upper wavelength source is denoted by 2.
parameters:	none
response:	Returns the frequency difference as a float value in Hz.
example:	wav:freq? → -1.00000000E+013<END>
affects:	All tunable laser sources

command:	[[:SOURce[n]][:CHANnel[m]]:WAVelength:REFerence[1]?
syntax:	[[:SOURce[n]][:CHANnel[m]]:WAVelength:REFerence[1]?
description:	Returns the reference wavelength (λ_0).
parameters:	none
response:	The wavelength as a <i>float</i> value in meters.
example:	sour2:wav:ref? → +1.5500000E-006<END>
affects:	All tunable laser and DFB modules

command:	[[:SOURce[n]][:CHANnel[m]]:WAVelength:REFerence:DISPlay
syntax:	[[:SOURce[n]][:CHANnel[m]]:WAVelength:REFerence:DISPlay
description:	Sets the reference wavelength to the value of the output wavelength ($\lambda \rightarrow \lambda_0$), that is, sets the frequency offset (df) to zero.
parameters:	none
response:	none
example:	sour2:wav:ref:disp
affects:	All tunable laser and DFB modules

command:	[[:SOURce[n]][:CHANnel[m]]:WAVelength:SWEep:CHECKparams?																								
syntax:	[[:SOURce[n]][:CHANnel[m]]:WAVelength:SWEep:CHECKparams?																								
description:	Returns whether the currently set sweep parameters (sweep mode, sweep start, stop, width, etc.) are consistent. If there is a sweep configuration problem, the laser source is not able to pass a wavelength sweep.																								
parameters:	none																								
response:	A <i>string</i> with a detailed description of a configuration problem, or "OK" if the sweep is configured correctly. The responses shown below are all the possible configuration problem strings:																								
	<table border="1"> <thead> <tr> <th>Message</th> <th>Description</th> </tr> </thead> <tbody> <tr> <td>368,LambdaStop <=LambdaStart</td> <td>start wavelength must be smaller than stop wavelength</td> </tr> <tr> <td>369,sweepTime < min</td> <td>the total time of the sweep is too small</td> </tr> <tr> <td>370,sweepTime > max</td> <td>the total time of the sweep is too large</td> </tr> <tr> <td>371,triggerFreq > max</td> <td>the trigger frequency (calculated from sweep speed divided by sweep step) is too large</td> </tr> <tr> <td>372,step < min</td> <td>step size too small</td> </tr> <tr> <td>373,triggerNum > max</td> <td>the number of triggers exceeds the allowed limit</td> </tr> <tr> <td>374,LambdaLogging = On AND Modulation = On AND ModulationSource! = CoherenceControl</td> <td>The only allowed modulation source with the lambda logging function is coherence control.</td> </tr> <tr> <td>375,LambdaLogging = On AND TriggerOut! = StepFinished</td> <td>lambda logging only works "Step Finished" output trigger configuration</td> </tr> <tr> <td>376,Lambda logging in stepped mode</td> <td>lambda logging can only be done in continuous sweep mode</td> </tr> <tr> <td>377,step not multiple of <x></td> <td>the step size must be a multiple of the smallest possible step size</td> </tr> <tr> <td>378, triggerFreq < min</td> <td>the number of triggers exceeds the allowed limit</td> </tr> </tbody> </table>	Message	Description	368,LambdaStop <=LambdaStart	start wavelength must be smaller than stop wavelength	369,sweepTime < min	the total time of the sweep is too small	370,sweepTime > max	the total time of the sweep is too large	371,triggerFreq > max	the trigger frequency (calculated from sweep speed divided by sweep step) is too large	372,step < min	step size too small	373,triggerNum > max	the number of triggers exceeds the allowed limit	374,LambdaLogging = On AND Modulation = On AND ModulationSource! = CoherenceControl	The only allowed modulation source with the lambda logging function is coherence control.	375,LambdaLogging = On AND TriggerOut! = StepFinished	lambda logging only works "Step Finished" output trigger configuration	376,Lambda logging in stepped mode	lambda logging can only be done in continuous sweep mode	377,step not multiple of <x>	the step size must be a multiple of the smallest possible step size	378, triggerFreq < min	the number of triggers exceeds the allowed limit
Message	Description																								
368,LambdaStop <=LambdaStart	start wavelength must be smaller than stop wavelength																								
369,sweepTime < min	the total time of the sweep is too small																								
370,sweepTime > max	the total time of the sweep is too large																								
371,triggerFreq > max	the trigger frequency (calculated from sweep speed divided by sweep step) is too large																								
372,step < min	step size too small																								
373,triggerNum > max	the number of triggers exceeds the allowed limit																								
374,LambdaLogging = On AND Modulation = On AND ModulationSource! = CoherenceControl	The only allowed modulation source with the lambda logging function is coherence control.																								
375,LambdaLogging = On AND TriggerOut! = StepFinished	lambda logging only works "Step Finished" output trigger configuration																								
376,Lambda logging in stepped mode	lambda logging can only be done in continuous sweep mode																								
377,step not multiple of <x>	the step size must be a multiple of the smallest possible step size																								
378, triggerFreq < min	the number of triggers exceeds the allowed limit																								
example:	sour0:wav:swe:chec? → "triggerNum > max"																								
affects:	All tunable laser modules except Agilent 81649A and Agilent 81689A/B																								

command:	[[:SOURce[n]][:CHANnel[m]]:WAVelength:SWEep:CYCLes
syntax:	[[:SOURce[n]][:CHANnel[m]]:WAVelength:SWEep:CYCLes<wsp><value> MIN MAX DEF 0
description:	Sets the number of cycles.
NOTE	Cannot be set while a sweep is running.
parameters:	The number of cycles is an integer value. Also allowed are: MIN: minimum programmable value MAX: maximum programmable value DEF: This is not the preset (*RST) default value but is half the sum of, the minimum programmable value and the maximum programmable value 0: cycles continuously.
response:	none
example:	wav:swe:cycl 3
affects:	All tunable laser modules

command:	[[:SOURce[n]][:CHANnel[m]]:WAVelength:SWEep:CYCLes?
syntax:	[[:SOURce[n]][:CHANnel[m]]:WAVelength:SWEep:CYCLes? [[<wsp>MIN MAX DEF]
description:	Returns the number of cycles.
parameters:	none Also allowed are: MIN: minimum programmable value MAX: maximum programmable value DEF: This is not the preset (*RST) default value but is half the sum of, the minimum programmable value and the maximum programmable value
response:	The number of cycles as an integer value.
example:	wav:swe:cycl? → +3<END>
affects:	All tunable laser modules

command:	[[:SOURce[n]][:CHANnel[m]]:WAVelength:SWEep:DWELI
syntax:	[[:SOURce[n]][:CHANnel[m]]:WAVelength:SWEep:DWELI<wsp> <value> MIN MAX DEF[NS US MS S]
description:	Sets the dwell time. Can only be used when sweep is stepped.
NOTE	Cannot be set while a sweep is running.
parameters:	The dwell time as a <i>float</i> value. If you specify no units in your command, seconds are used as the default. Also allowed are: MIN: minimum programmable value MAX: maximum programmable value DEF: This is not the preset (*RST) default value but is half the sum of, the minimum programmable value and the maximum programmable value
response:	none
example:	wav:swe:dwel 500ms
affects:	All tunable laser modules

command:	[[:SOURce[n]][:CHANnel[m]]:WAVelength:SWEep:DWELI?
syntax:	[[:SOURce[n]][:CHANnel[m]]:WAVelength:SWEep:DWELI?[<wsp>MIN MAX DEF]
description:	Returns the dwell time. Can only be used when sweep is stepped.
parameters:	none Also allowed are: MIN: minimum programmable value MAX: maximum programmable value DEF: This is not the preset (*RST) default value but is half the sum of, the minimum programmable value and the maximum programmable value
response:	The dwell time in seconds.
example:	wav:swe:dwel? → +5.00000000E-001<END>
affects:	All tunable laser modules

command:	[[:SOURce[n]][:CHANnel[m]]:WAVelength:SWEep:EXPEctedtriggers?
syntax:	[[:SOURce[n]][:CHANnel[m]]:WAVelength:SWEep:EXPEctedtriggers?
description:	Returns the number of triggers. A tunable laser wavelength sweep causes a number of triggers, this number is required to configure a triggering data acquisition function on a power meter. The number returned by this function can be used to configure a Power Meter for co-ordinated measurements with a tunable laser source (see command “:SENSe[n]:CHANnel[m]:FUNctio:n:PARAMeter:LOGGing” on page 94).
parameters:	none
response:	the number of expected triggers as an unsigned integer value.
example:	sour0:wav:swe:exp? → 12001
affects:	All tunable laser modules except Agilent 81649A and Agilent 81689A/B

command:	[:SOURce[n]][:CHANnel[m]]:WAVelength:SWEep:FLAG?	
syntax:	[:SOURce[n]][:CHANnel[m]]:WAVelength:SWEep:FLAG?	
description:	<p>The sweep flag is used to find out when logging data is available and when the next sweep cycle may be triggered.</p> <p>It may also be used as a sweep cycle counter, where: $\text{flag}/2 = \text{number of sweep cycles}$</p> <p>The flag is:</p> <ul style="list-style-type: none"> - only used in continuous sweep - set to 0 at start/end of sweep - incremented when the sweep is waiting for a trigger - incremented when logging data is available - an odd number when, waiting for a trigger - an even number when, logging data may be read <p>If the trigger input isn't configured to start a sweep cycle the flag is increased by two when the logging data is available</p> <p>If no logging data is calculated, because the user doesn't want lambda logging, the flag is incremented at the end of the sweep cycle regardless</p>	
	Sweep state	Flag
	start	0
	sweep waiting for trigger	1
	trigger → first cycle start moving back do some post-processing logging data available	2
	sweep waiting for next trigger	3
	
	sweep stopped or finished	0
parameters:	none	
response:	the current sweep flag value as an unsigned integer value	
example:	sour0:wav:swe:flag? → 30	
affects:	All tunable laser modules except Agilent 81649A and Agilent 81689A/B	

command:	[:SOURce[n]] [:CHANnel[m]] :WAVelength:SWEEp:LLOGging
syntax:	[:SOURce[n]] [:CHANnel[m]] :WAVelength:SWEEp:LLOGging<wsp>OFF ON 0 1
description:	Switches lambda logging on or off. Lambda logging is a feature that records the exact wavelength of a tunable laser module when a trigger is generated during a continuous sweep. You can read this data using the [:SOURce[n]] [:CHANnel[m]] :READout:DATA? command.
NOTE	The following settings are the prerequisites for Lambda Logging: Set “[:SOURce[n]][:CHANnel[m]]:WAVelength:SWEEp:MODE” on page 141 to CONTInuous. Set “:TRIGger[n]:CHANnel[m]:OUTPut” on page 176 to STFinished (step finished). Set “[:SOURce[n]][:CHANnel[m]]:WAVelength:SWEEp:CYCLes” on page 137 to 1. Set “[:SOURce[n]][:CHANnel[m]]:AM:STATe[]” on page 117 to OFF. If any of the above prerequisites are not met, then when the sweep is started the status "Sweep parameters inconsistent" will be returned and Lambda Logging will automatically be turned off.
NOTE	Lambda logging is disabled at the end of a sweep.
NOTE	Generally, a continuous sweep can only be started if: the trigger frequency, derived from the sweep speed and sweep step, is <= 40kHz the number of triggers, calculated from the sweep span and sweep span, is <=100001 the start wavelength is less than the stop wavelength. In addition, a continuous sweep with lambda logging requires: the trigger output to be set to step finished modulation set to coherence control or off.
parameters:	0 or OFF: switch lambda logging off 1 or ON: switch lambda logging on
response:	none
example:	wav:swe:llog 1
affects:	All tunable laser modules except Agilent 81649A and Agilent 81689A/B

command:	[:SOURce[n]] [:CHANnel[m]] :WAVelength:SWEEp:LLOGging?
syntax:	[:SOURce[n]] [:CHANnel[m]] :WAVelength:SWEEp:LLOGging?
description:	Returns the state of lambda logging.
parameters:	none
response:	A <i>boolean</i> value: 0 – lambda logging is switched off 1 – lambda logging is switched on
example:	wav:swe:llog? → 1<END>
affects:	All tunable laser modules except Agilent 81649A and Agilent 81689A/B

command:	[[:SOURce[n]][:CHANnel[m]]:WAVelength:SWEep:MODE						
syntax:	[[:SOURce[n]][:CHANnel[m]]:WAVelength:SWEep:MODE<wsp><mode>						
description:	Sets the sweep mode.						
	NOTE Cannot be set while a sweep is running.						
parameters:	<table> <tr> <td>STEPped:</td> <td>Stepped sweep mode</td> </tr> <tr> <td>MANual:</td> <td>Manual sweep mode</td> </tr> <tr> <td>CONTinuous:</td> <td>Continuous sweep mode</td> </tr> </table>	STEPped:	Stepped sweep mode	MANual:	Manual sweep mode	CONTinuous:	Continuous sweep mode
STEPped:	Stepped sweep mode						
MANual:	Manual sweep mode						
CONTinuous:	Continuous sweep mode						
response:	none						
example:	wav:swe:mode STEP						
affects:	All tunable laser modules except Agilent 81649A, Agilent 81689A/B and 819x9A						

command:	[[:SOURce[n]][:CHANnel[m]]:WAVelength:SWEep:MODE?						
syntax:	[[:SOURce[n]][:CHANnel[m]]:WAVelength:SWEep:MODE?						
description:	Returns the sweep mode.						
parameters:	none						
response:	<table> <tr> <td>STEP:</td> <td>Stepped sweep mode</td> </tr> <tr> <td>MAN:</td> <td>Manual sweep mode</td> </tr> <tr> <td>CONT:</td> <td>Continuous sweep mode</td> </tr> </table>	STEP:	Stepped sweep mode	MAN:	Manual sweep mode	CONT:	Continuous sweep mode
STEP:	Stepped sweep mode						
MAN:	Manual sweep mode						
CONT:	Continuous sweep mode						
example:	wav:swe:mode? → STEP<END>						
affects:	All tunable laser modules						

command:	[[:SOURce[n]][:CHANnel[m]]:WAVelength:SWEep:PMAX?				
syntax:	[[:SOURce[n]][:CHANnel[m]]:WAVelength:SWEep:PMAX?<wsp><start wavelength>, <stop wavelength>				
description:	Returns the power to the highest permissible power for the selected wavelength sweep.				
parameters:	<table> <tr> <td>start wavelength:</td> <td>The wavelength at which the sweep starts as a float value.</td> </tr> <tr> <td>stop wavelength:</td> <td>The wavelength at which the sweep starts as a float value.</td> </tr> </table>	start wavelength:	The wavelength at which the sweep starts as a float value.	stop wavelength:	The wavelength at which the sweep starts as a float value.
start wavelength:	The wavelength at which the sweep starts as a float value.				
stop wavelength:	The wavelength at which the sweep starts as a float value.				
response:	The highest permissible power for the selected wavelength sweep as a float value.				
example:	wav:swe:pmax? 1540nm,1550nm → +3.5500000E-004<END>				
affects:	All tunable laser modules				

command:	[[:SOURce[n]][:CHANnel[m]]:WAVelength:SWEep:REPeat
syntax:	[[:SOURce[n]][:CHANnel[m]]:WAVelength:SWEep:REPeat<wsp><mode>
description:	Sets the repeat mode. Applies in stopped-sweep and manual-sweep modes.
parameters:	<p>ONEWay: Every stepped or continuous sweep cycle starts at the start wavelength of the sweep and ends at the stop wavelength of the sweep</p> <p>TWOWay: Every odd stepped sweep cycle starts at the start wavelength of the sweep, and every even stepped sweep cycle starts at the stop wavelength of the sweep.</p> <p>Set the start and stop wavelength of the sweep using <i>“[:SOURce[n]][:CHANnel[m]]:WAVelength:SWEep:START” on page 144 and “[:SOURce[n]][:CHANnel[m]]:WAVelength:SWEep:STOP” on page 144 respectively.</i></p>
response:	none
example:	wav:swe:rep twow
affects:	All tunable laser modules

command:	[[:SOURce[n]][:CHANnel[m]]:WAVelength:SWEep:REPeat?
syntax:	[[:SOURce[n]][:CHANnel[m]]:WAVelength:SWEep:REPeat?
description:	Returns the repeat mode.
parameters:	none
response:	<p>ONEWay: Every stepped or continuous sweep cycle starts at the start wavelength of the sweep and ends at the stop wavelength of the sweep</p> <p>TWOWay: Every odd stepped sweep cycle starts at the start wavelength of the sweep, and every even stepped sweep cycle starts at the stop wavelength of the sweep.</p> <p>Set the start and stop wavelength of the sweep using <i>“[:SOURce[n]][:CHANnel[m]]:WAVelength:SWEep:START” on page 144 and “[:SOURce[n]][:CHANnel[m]]:WAVelength:SWEep:STOP” on page 144 respectively.</i></p>
example:	wav:swe:rep? → ONEW<END>
affects:	All tunable laser modules

command:	[:SOURce[n]][:CHANnel[m]]:WAVelength:SWEEp:SOFTtrigger
syntax:	[:SOURce[n]][:CHANnel[m]]:WAVelength:SWEEp:SOFTtrigger
description:	Softtrigger does the same as a normal (hardware) trigger at the backplane, but it doesn't cause a PM to take a measurement because it is only a (software) message sent to the tunable laser source. It only works in continuous sweep. Usage: - Trigger input configuration: Start Sweep - Start Sweep - SoftTrigger
parameters:	none
response:	none
example:	sour0:wav:sweep:soft
affects:	All tunable laser modules except Agilent 81649A and Agilent 81689A/B

command:	[:SOURce[n]][:CHANnel[m]]:WAVelength:SWEEp:SPEEd
syntax:	[:SOURce[n]][:CHANnel[m]]:WAVelength:SWEEp:SPEEd<wsp><speed> [NM/S UM/S MM/S M/S]
description:	Sets the speed for continuous sweeping. NOTE Cannot be set while a sweep is running.
parameters:	Speed as a float value in meters per second (m/s).
response:	none
example:	wav:swe:spe 10nm/s
affects:	All tunable laser modules except Agilent 81649A and Agilent 81689A/B

command:	[:SOURce[n]][:CHANnel[m]]:WAVelength:SWEEp:SPEEd?
syntax:	[:SOURce[n]][:CHANnel[m]]:WAVelength:SWEEp:SPEEd?[<wsp>MIN MAX]
description:	Returns the speed for continuous sweeping.
parameters:	optional MIN Returns the minimum sweep speed available. MAX Returns the maximum sweep speed available.
response:	Speed as a float value in meters per second (m/s).
example:	wav:swe:spe? → +5.00000000E-008<END>
affects:	All tunable laser modules except Agilent 81649A and Agilent 81689A/B

command:	[[:SOURce[n]][:CHANnel[m]]:WAVelength:SWEep:START
syntax:	[[:SOURce[n]][:CHANnel[m]]:WAVelength:SWEep:START<wsp><start value> [PM NM UM MM M]
description:	Sets the starting point of the sweep.
NOTE	Cannot be set while a sweep is running.
parameters:	The wavelength at which the sweep starts as a float value. If you specify no units in your command, meters are used as the default.
response:	none
example:	wav:swe:star 1500nm
affects:	All tunable laser modules

command:	[[:SOURce[n]][:CHANnel[m]]:WAVelength:SWEep:START?
syntax:	[[:SOURce[n]][:CHANnel[m]]:WAVelength:SWEep:START?[<wsp>MIN MAX]
description:	Returns the starting point of the sweep.
parameters:	optional MIN Returns the minimum start wavelength available. This value is wavelength dependent. MAX Returns the maximum start wavelength available. This value is wavelength dependent.
response:	The wavelength at which the sweep starts as a float value in meters.
example:	wav:swe:star? → +1.50000000E-006<END>
affects:	All tunable laser modules

command:	[[:SOURce[n]][:CHANnel[m]]:WAVelength:SWEep:STOP
syntax:	[[:SOURce[n]][:CHANnel[m]]:WAVelength:SWEep:STOP<wsp><stop value> [PM NM UM MM M]
description:	Sets the end point of the sweep.
NOTE	Cannot be set while a sweep is running.
parameters:	The wavelength at which the sweep ends as a float value in meters. If you specify no units in your command, meters are used as the default.
response:	none
example:	wav:swe:stop 1550nm
affects:	All tunable laser modules

command:	[[:SOURce[n]][:CHANnel[m]]:WAVelength:SWEep:STOP?
syntax:	[[:SOURce[n]][:CHANnel[m]]:WAVelength:SWEep:STOP?[<wsp>MIN MAX]
description:	Returns the end point of the sweep.
parameters:	optional MIN Returns the minimum start wavelength available. This value is wavelength dependent. MAX Returns the maximum start wavelength available. This value is wavelength dependent.
response:	The wavelength at which the sweep ends as a float value in meters.
example:	wav:swe:stop? → +1.55000000E-006<END>
affects:	All tunable laser modules

command:	[[:SOURce[n]][:CHANnel[m]]:WAVelength:SWEep:[STATe]
syntax:	[[:SOURce[n]][:CHANnel[m]]:WAVelength:SWEep:[STATe]<wsp> STOP 0 START 1 PAUSE 2 CONTINUE 3
description:	Stops, starts, pauses or continues a wavelength sweep.
parameters:	0 or STOP: Stop the sweep. 1 or START: Start a sweep, run sweep. 2 or PAUSE: Pause the sweep. (doesn't apply for continuous sweep) 3 or CONTINUE: Continue a sweep. (doesn't apply for continuous sweep)
NOTE	If you enable lambda logging (see " <i>[[:SOURce[n]][:CHANnel[m]]:WAVelength:SWEep:LLOGging</i> " on page 140) and modulation (see " <i>[[:SOURce[n]][:CHANnel[m]]:AM:STATe[!]</i> " on page 117) simultaneously, a sweep cannot be started.
NOTE	Generally, a continuous sweep can only be started if: the trigger frequency, derived from the sweep speed and sweep step, is <= 40kHz the number of triggers, calculated from the sweep span and sweep span, is <=100001 the start wavelength is less than the stop wavelength. In addition, a continuous sweep with lambda logging requires: the trigger output to be set to step finished modulation set to coherence control or off.
response:	none
example:	wav:swe STOP
affects:	All tunable laser modules

command:	[[:SOURce[n]][:CHANnel[m]]:WAVelength:SWEep:STATe]?
syntax:	[[:SOURce[n]][:CHANnel[m]]:WAVelength:SWEep:STATe]?
description:	Returns the state of a sweep.
parameters:	none
response:	+0: Sweep is not running +1: Sweep is running
example:	wav:swe? → +0<END>
affects:	All tunable laser modules

command:	[[:SOURce[n]][:CHANnel[m]]:WAVelength:SWEep:STEP:NEXt]
syntax:	[[:SOURce[n]][:CHANnel[m]]:WAVelength:SWEep:STEP:NEXt]
description:	Performs the next sweep step in stepped sweep if it is paused or in manual sweep.
parameters:	none
response:	none
example:	wav:swe:step:next
affects:	All tunable laser modules

command:	[[:SOURce[n]][:CHANnel[m]]:WAVelength:SWEep:STEP:PREVious]
syntax:	[[:SOURce[n]][:CHANnel[m]]:WAVelength:SWEep:STEP:PREVious]
description:	Performs one sweep step backwards in stepped sweep if it is paused or in manual sweep.
parameters:	none
response:	none
example:	wav:swe:step:prev
affects:	All tunable laser modules

command:	[[:SOURce[n]][:CHANnel[m]]:WAVelength:SWEep:STEP:[WIDTh]
syntax:	[[:SOURce[n]][:CHANnel[m]]:WAVelength:SWEep:STEP:[WIDTh]<wsp> <value>[PM NM UM MM M]
description:	Sets the width of the sweep step. In continuous sweep mode, the end of a step is used for triggering.
parameters:	The width of the sweep step as a <i>float</i> value. If you specify no units in your command, meters are used as the default.
response:	none
example:	wav:swe:step 5nm
affects:	All tunable laser modules

command:	[[:SOURce[n]][:CHANnel[m]]:WAVelength:SWEep:STEP:[WIDTh]?
syntax:	[[:SOURce[n]][:CHANnel[m]]:WAVelength:SWEep:STEP:[WIDTh]?[<wsp>MIN MAX]
description:	Returns the width of the sweep step
parameters:	optional MIN Returns the minimum step width available. MAX Returns the maximum step width available.
response:	The sweep step as a float value in meters.
example:	wav:swe:step? → +5.00000000E-009<END>
affects:	All tunable laser modules

Signal Conditioning

The commands in this section allow you to control Agilent 8156x, and 8157x Attenuator modules

The INPut and OUTput commands

command:	:INPut[<i>n</i>][:CHANnel[<i>m</i>]:ATTenuation
syntax:	:INPut[<i>n</i>][:CHANnel[<i>m</i>]:ATTenuation<wsp><value>[dB] MIN DEF MAX
description:	<p>Sets the attenuation factor (α) for the instrument. The attenuation factor is used, together with an offset factor (α_{Offset}) to set the filter attenuation (α_{filter}).</p> $\alpha_{(\text{new})} \text{ (dB)} = \alpha_{\text{filter}(\text{new})} \text{ (dB)} + \alpha_{\text{Offset}} \text{ (dB)}$ <p>Set the attenuation factor by sending a value (the default units are dB), or by sending MIN, DEF, or MAX.</p>
parameters:	<p><value>[dB] The attenuation in dB.</p> <p>MIN DEF The values where $\alpha_{\text{filter}} = 0\text{dB}$</p> <p>MAX The value where α_{filter} is at its greatest.</p>
response:	none
example:	INP1:ATT 14dB
affects:	All attenuator modules

command:	:INPut[<i>n</i>][:CHANnel[<i>m</i>]:ATTenuation?
syntax:	:INPut[<i>n</i>][:CHANnel[<i>m</i>]:ATTenuation?<wsp> MIN DEF MAX
description:	<p>Returns the current attenuation factor (α), in dB.</p> $\alpha \text{ (dB)} = \alpha_{\text{filter}} \text{ (dB)} + \alpha_{\text{Offset}} \text{ (dB)}$
parameters:	MIN DEF MAX Returns the minimum, default, or maximum value of the attenuation factor possible.
response:	4 byte Intel floating point; attenuation in dB.
example:	INP1:ATT? → 14<END>
affects:	All attenuator modules

command:	:INPut[n][:CHANnel[m]]:OFFSet
syntax:	:INPut[n][:CHANnel[m]]:OFFSet<wsp><value>[dB] MIN DEF MAX
description:	<p>Sets the offset factor (α_{Offset}) for the instrument. This factor does not affect the filter attenuation (α_{filter}). It is used to offset the attenuation factor values. This offset factor is used, with the attenuation factor, to set the attenuation of the filter. In this way it is possible to compensate for external losses.</p> $\alpha_{(\text{new})} (\text{dB}) = \alpha_{\text{filter}} (\text{dB}) + \alpha_{\text{Offset}(\text{new})} (\text{dB})$ <p>Set the offset factor by sending a value (the default units are dB), or by sending MIN, DEF, or MAX.</p>
parameters:	<p><value>[dB] The offset factor (α_{Offset}) in dB.</p> <p>MIN Sets the minimum value for $\alpha_{\text{Offset}} = -200\text{dB}$.</p> <p>DEF Sets the default value for $\alpha_{\text{Offset}} = 0\text{dB}$.</p> <p>MAX Sets the maximum value for $\alpha_{\text{Offset}} = +200\text{dB}$.</p>
response:	none
example:	INP1:OFFS 2dB
affects:	All attenuator modules

command:	:INPut[n][:CHANnel[m]]:OFFSet?
syntax:	:INPut[n][:CHANnel[m]]:OFFSet?<wsp>MIN DEF MAX
description:	Returns the current value of the offset factor (α_{Offset}), in dB.
parameters:	MIN DEF MAX Returns the minimum, default, or maximum value of the offset factor.
response:	4 byte Intel floating point; offset in dB.
example:	INP1:OFFS? → 2<END>
affects:	All attenuator modules

command:	:INPut[n][:CHANnel[m]]:OFFSet:DISPlay
syntax:	:INPut[n][:CHANnel[m]]:OFFSet:DISPlay
description:	<p>Sets the offset factor (α_{Offset}) such that the attenuation factor is zero.</p> $\alpha_{\text{Offset}(\text{new})} (\text{dB}) = \alpha_{\text{Offset}(\text{old})} (\text{dB}) - \alpha_{(\text{old})} (\text{dB}) = -\alpha_{\text{filter}} (\text{dB})$
parameters:	none
response:	none
example:	INP1:OFFS:DISP
affects:	All attenuator modules

command:	:INPut[<i>n</i>][:CHANnel[<i>m</i>]]:OFFSet:POWermeter
syntax:	:INPut[<i>n</i>][:CHANnel[<i>m</i>]]:OFFSet:POWermeter<wsp><slot>,<channel>
description:	Sets the offset factor (α_{Offset}) to the difference between a power value measured by another powermeter (hosted by the same mainframe) (P_{ext}) and the power value measured by the attenuator module's monitor diode (P_{att}). $\alpha_{\text{Offset}} \text{ (dB)} = P_{\text{att}} \text{ (dBm)} - P_{\text{ext}} \text{ (dBm)}$
parameters:	<slot> Slot number of the external powermeter. <channel> Channel number of the external powermeter.
response:	none
example:	INP1:OFFS:POW 4,2
affects:	Attenuator modules with power control.

command:	:INPut[<i>n</i>][:CHANnel[<i>m</i>]]:ATTenuation:SPEed
syntax:	:INPut[<i>n</i>][:CHANnel[<i>m</i>]]:ATTenuation:SPEed<wsp><value> MIN MAX DEF
description:	Sets the filter transition speed; the speed at which the module moves from one attenuation to another (in dB/s).
parameters:	<value> The filter transition speed in dB/s. MIN MAX DEF Sets the filter transition speed to the module limits, or the module default.
response:	none
example:	INP1:ATT:SPE 2
affects:	All attenuator modules.

command:	:INPut[<i>n</i>][:CHANnel[<i>m</i>]]:ATTenuation:SPEed?
syntax:	:INPut[<i>n</i>][:CHANnel[<i>m</i>]]:ATTenuation:SPEed?<wsp> MIN MAX DEF
description:	Without the optional parameter, queries the transition speed of the filter.
parameters:	MIN MAX DEF Queries the transition speed limits, or the module default.
response:	4 byte Intel floating point; transition speed in dB/s.
example:	INP1:ATT:SPE? → 2<END>
affects:	All attenuator modules.

command:	:INPut[n][:CHANnel[m]]:WAVelength
syntax:	:INPut[n][:CHANnel[m]]:WAVelength<wsp><value>[PM NM UM MM M] MIN MAX DEF
description:	Sets the attenuator module's operating wavelength. This value is used to compensate for the wavelength dependence of the filter, and to calculate a wavelength dependent offset from the user offset table (if enabled).
parameters:	<value> The wavelength in meters (if you do not specify a unit). MIN MAX DEF Sets the wavelength to the module limits, or the module default.
response:	none
example:	INP1:WAV +1.55000000E-006
affects:	All attenuator modules.

command:	:INPut[n][:CHANnel[m]]:WAVelength?
syntax:	:INPut[n][:CHANnel[m]]:WAVelength?<wsp>MIN MAX DEF
description:	Without the optional parameter, queries the operating wavelength of the attenuator.
parameters:	MIN MAX DEF Queries the operating wavelength limits, or the module default.
response:	4 byte Intel floating point; wavelength in m.
example:	INP1:WAV → +1.55000000E-006<END>
affects:	All attenuator modules.

command:	:OUTPutn[:CHANnel[m]]:APMode
syntax:	:OUTPutn[:CHANnel[m]]:APMode<wsp><OFF(0) ON(1)>
description:	The use of this command is optional and has no effect on operation. Included for compatibility with Agilent 8156A mainframe.
parameters:	OFF or 0 ON or 1
response:	none
example:	OUTP1:APMode OFF
affects:	All attenuator modules.

command:	:OUTPut<i>n</i>[:CHANnel<i>m</i>]:APMode?
syntax:	:OUTPut <i>n</i> [:CHANnel <i>m</i>]:APMode?
description:	Queries whether the user has amended the power value or the attenuation value. This use of this command is optional. Included for compatibility with Agilent 8156A mainframe.
parameters:	none
response:	<i>boolean</i> 0 User has amended the attenuation value. 1 User has amended the power value.
example:	OUTP1:APMode? → 0<END>
affects:	All attenuator modules.

command:	:OUTPut<i>n</i>[:CHANnel<i>m</i>]:POWer
syntax:	:OUTPut <i>n</i> [:CHANnel <i>m</i>]:POWer<wsp><value>[PW NW UW MW W DBM] MIN MAX DEF
description:	Sets the output power value (P). If your attenuator module does not include the power control feature, the new filter attenuation ($\alpha_{\text{filter (new)}}$) is calculated from the reference power (P_{ref}): $P_{\text{set(new)}} (\text{dBm}) = P_{\text{ref}} (\text{dBm}) - \alpha_{\text{filter (new)}} (\text{dB}) - P_{\text{offset}} (\text{dB})$ If your attenuator module includes the power control feature, the filter attenuation is changed until the set power (measured by the module's internal power meter) has been reached. $P_{\text{set(new)}} (\text{dBm}) = P_{\text{att(new)}} (\text{dBm}) - P_{\text{offset}} (\text{dB})$ If the set power cannot be achieved ExP (indicating 'Excessive Power') is displayed, and the appropriate GPIB status bit is set. The status of these bits can be queried using ":STATus:QUEStionable:CONDition[:LEVel0]?" on page 71
parameters:	<value> Desired output power (if unit not specified current unit is used). MIN MAX DEF Sets the output power to the module limits, or the module default.
response:	none
example:	OUTP1:POW 12
affects:	All attenuator modules.

command:	:OUTPut<i>n</i>[:CHANnel<i>m</i>]:POWer?
syntax:	:OUTPut <i>n</i> [:CHANnel <i>m</i>]:POWer<wsp>MIN MAX DEF
description:	Without the optional parameter, queries the output power value.
parameters:	MIN MAX DEF Queries the output power module limits, or the module default.
response:	4 byte Intel floating point; output power in current power unit.
example:	OUTP1:POW? → 12<END>
affects:	All attenuator modules.

command:	:OUTPutn[:CHANnel[m]]:POWer:REference
syntax:	:OUTPutn[:CHANnel[m]]:POWer:REference<wsp><value>[PW NW UW MW W DBM] MIN MAX DEF
description:	Sets the reference power (P_{ref}). The reference power is used to calculate the filter attenuation (α_{filter}) from the output power (P). A change to the reference power does not affect the filter attenuation. $P_{set(new)}(dBm) = P_{ref(new)}(dBm) - \alpha_{filter}(dB) - P_{Offset}(dB)$
parameters:	<value> Desired reference power (if unit not specified current unit is used). MIN MAX DEF Sets the reference power to the module limits, or the module default.
response:	none
example:	OUTP1:POW:REF 6dBm
affects:	Attenuator modules without power control.

command:	:OUTPutn[:CHANnel[m]]:POWer:REference?
syntax:	:OUTPutn[:CHANnel[m]]:POWer:REference?<wsp>MIN MAX DEF
description:	Without the optional parameter, queries the reference power value.
parameters:	MIN MAX DEF Queries the reference power limits, or the module default.
response:	4 byte Intel floating point; reference power in current power unit.
example:	OUTP1:POW:REF? → 6<END>
affects:	Attenuator modules without power control.

command:	:OUTPutn[:CHANnel[m]]:POWer:REference:POWermeter
syntax:	:OUTPutn[:CHANnel[m]]:POWer:REference:POWer<wsp><slot>,<channel>
description:	Copies the power value (P_{ext}) from an external powermeter module (hosted by the same mainframe) to the attenuator module's reference power parameter (P_{ref}): $P_{ref}(dBm) = P_{ext}(dBm) + \alpha_{filter}(dB)$
parameters:	<slot> Slot number of the powermeter. <channel> Channel number of the powermeter.
response:	none
example:	OUTP1:POW:REF:POW 4,2
affects:	Attenuator modules without power control.

command:	:OUTPutn[:CHANnel[m]]:POWer:OFFSet
syntax:	:OUTPutn[:CHANnel[m]]:POWer:OFFSet<wsp><value>[DB] MIN MAX DEF
description:	Sets a power offset (P_{offset}). This factor is used to offset the power value. It does not affect the filter, nor does it change the power output at the attenuator module. $P_{\text{set(new)}} (\text{dBm}) = P_{\text{att}} (\text{dBm}) - P_{\text{offset(new)}} (\text{dB})$ <p>If the wavelength offset table is enabled, the corresponding λ offset is added to this offset.</p>
parameters:	<value> The power offset required, in dB MIN MAX DEF Queries the module limits, or the default.
response:	none
example:	OUTP1:POW:OFFS 2
affects:	Attenuator modules with power control.

command:	:OUTPutn[:CHANnel[m]]:POWer:OFFSet?
syntax:	:OUTPutn[:CHANnel[m]]:POWer:OFFSet? <wsp>MIN MAX DEF
description:	Without the optional parameter, queries the power offset value.
parameters:	MIN MAX REF Queries the power offset limits, or the module default.
response:	4 byte Intel floating point; power offset in current power units.
example:	OUTP1:POW:OFFS? → 2<END>
affects:	Attenuator modules with power control.

command:	:OUTPutn[:CHANnel[m]]:POWer:OFFSet:POWermeter
syntax:	:OUTPutn[:CHANnel[m]]:POWer:OFFSet:POWermeter<wsp><slot>,<channel>
description:	Calculates the power offset by subtracting the power value measured by another powermeter (hosted by the same mainframe) from the power value measured by the attenuator's integrated powermeter, and stores it as P_{offset} . $P_{\text{offset(new)}} (\text{dBm}) = P_{\text{att}} (\text{dBm}) - P_{\text{ext}} (\text{dBm}) + P_{\text{offset}(\lambda)} (\text{dB})$
parameters:	<slot> Slot number of the external powermeter. <channel> Channel number of the external powermeter.
response:	none
example:	OUTP1:POW:OFFS:POW 4,4
affects:	Attenuator modules with power control.

command:	:OUTPutn[:CHANnel[m]]:POWer:CONTRol
syntax:	:OUTPutn[:CHANnel[m]]:POWer:CONTRol<wsp>OFF(0) ON(1)
description:	Sets whether the power control mode is on or off. If power control is enabled, the attenuator automatically compensates for changes to input power.
parameters:	OFF or 0 Output power follows changes to input power. ON or 1 The filter position automatically adjusts to compensate for changes to input power, so maintaining the output power set by the user.
response:	none
example:	OUTP1:POW:CONTR ON
affects:	Attenuator modules with power control.

command:	:OUTPutn[:CHANnel[m]]:POWer:CONTRol?
syntax:	:OUTPutn[:CHANnel[m]]:POWer:CONTRol?
description:	Queries whether the power control mode is on or off.
parameters:	none
response:	<i>boolean</i> 0 The power control mode is off 1 The power control mode is on.
example:	OUTP1:POW:CONTR? → 0<END>
affects:	Attenuator modules with power control.

command:	:OUTPutn[:CHANnel[m]]:POWer:UNit
syntax:	:OUTPutn[:CHANnel[m]]:POWer:UNit<wsp>DBM(0) WATT(1)
description:	Sets whether the power unit used is dBm or Watts. This setting affects P_{set} , P_{ref} (if available), and P_{act}
parameters:	DBM (or 0) Sets the power unit to dBm WATT (or 1) Sets the power unit to W
response:	none
example:	OUTP1:POW:UN DBM
affects:	All attenuator modules.

command:	:OUTPutn[:CHANnel[m]]:POWer:UNit?
syntax:	:OUTPutn[:CHANnel[m]]:POWer:UNit?
description:	Queries whether the power unit is dBm or W
parameters:	none
response:	<i>boolean</i> 0 The power unit is dBm 1 The power unit is W.
example:	OUTP1:POW:UN? → 0<END>
affects:	All attenuator modules.

command:	:OUTPutn[:CHANnel[m]]:[STATe]
syntax:	:OUTPutn[:CHANnel[m]]:[STATe]<wsp>OFF(0) ON(1)
description:	Sets the state of the shutter.
parameters:	OFF or 0 Shutter closed. ON or 1 Shutter open.
response:	none
example:	OUTP1:STAT OFF
affects:	All attenuator modules.

command:	:OUTPutn[:CHANnel[m]]:[STATe]?
syntax:	:OUTPutn[:CHANnel[m]]:[STATe]?
description:	Queries the state of the shutter.
parameters:	none
response:	<i>boolean</i> 0 The shutter is open. 1 The shutter is closed.
example:	OUTP1:STAT? → 0<END>
affects:	All attenuator modules.

command:	:OUTPutn[:CHANnel[m]]:STATe:APOWeron
syntax:	:OUTPutn[:CHANnel[m]]:STATe:APOWeron<wsp>OFF(0) ON(1)
description:	Sets the state of the shutter when the mainframe is turned on.
parameters:	OFF or 0 Shutter closed after mainframe power on. ON or 1 Shutter open after mainframe power on.
response:	none
example:	OUTP1:APOW OFF
affects:	All attenuator modules.

command:	:OUTPutn[:CHANnel[m]]:STATe:APOWeron?
syntax:	:OUTPutn[:CHANnel[m]]:STATe:APOWeron?
description:	Queries the state of the shutter at power on.
parameters:	none
response:	<i>boolean</i> 0 The shutter is open after mainframe power on. 1 The shutter is closed after mainframe power on.
example:	OUTP1:APOW? → 0<END>
affects:	All attenuator modules.

command:	:OUTPutn[:CHANnel[m]]:ATIMe
syntax:	:OUTPutn[:CHANnel[m]]:ATIMe<wsp><value>[NS US MS S]
description:	Sets the powermeter averaging time, which can, if the attenuator's power control feature is activated, affect how the attenuator compensates for changes to input power.
parameters:	<value> The averaging time (in seconds if no unit specified).
response:	none
example:	OUTP1:ATIM 1s
affects:	Attenuator modules with power control.

command:	:OUTPutn[:CHANnel[m]]:ATIMe?
syntax:	:OUTPutn[:CHANnel[m]]:ATIMe?
description:	Queries the powermeter averaging time.
parameters:	none
response:	<i>4 byte Intel floating point; the averaging time in seconds</i>
example:	OUTP1:ATIM? → 1<END>
affects:	Attenuator modules with power control.

command:	:OUTPutn[:CHANnel[m]]:CORRection:COLLection:ZERO
syntax:	:OUTPutn[:CHANnel[m]]:CORRection:COLLection:ZERO
description:	Zeros the electrical offsets of the attenuator's integrated powermeter.
parameters:	none
response:	none
example:	OUTP1:CORR:COLL:ZERO
affects:	Attenuator modules with power control.

command:	:OUTPut<i>n</i>:CHANnel[<i>m</i>]:CORRection:COLLection:ZERO:ALL
syntax:	:OUTPut <i>n</i> :CHANnel[<i>m</i>]:CORRection:COLLection:ZERO:ALL
description:	Zero all available powermeter channels in the mainframe.
parameters:	none
response:	none
example:	OUTP1:CORR:COLL:ZERO:ALL
affects:	Powermeter modules; attenuator modules with power control, and return loss modules.

command:	:OUTPut<i>n</i>:CHANnel[<i>m</i>]:CORRection:COLLection:ZERO?
syntax:	:OUTPut <i>n</i> :CHANnel[<i>m</i>]:CORRection:COLLection:ZERO?
description:	Queries the status of the last :OUTPut <i>n</i> :CHANnel[<i>m</i>]:CORRection:COLLection:ZERO operation.
parameters:	none
response:	integer 0 = OK, otherwise not OK.
example:	OUTP:CORR:COLL:ZERO? → 0<END>
affects:	Attenuator modules with power control.

The table of wavelength-dependent offsets

When enabled, the attenuator uses its λ offset table to compensate for wavelength dependent losses in the test set-up. This table contains, for each wavelength specified, the additional power offset to be applied.

- If the attenuator module is set to a wavelength corresponding to an entry in its λ offset table, the stored offset is added to the global power offset.
- If the attenuator module is set to a wavelength between entries in its λ offset table, linear interpolation is used to calculate the appropriate offset to add to the global power offset.
- If the attenuator module is set to a wavelength beyond the range of the entries in its λ offset table, the offset stored for the nearest wavelength is added to the global power offset.
- Whether an exact, interpolated, or extrapolated offset value is applied, the algorithm applied can be queried using “:STATusn:OPERation:CONDition?” on page 68

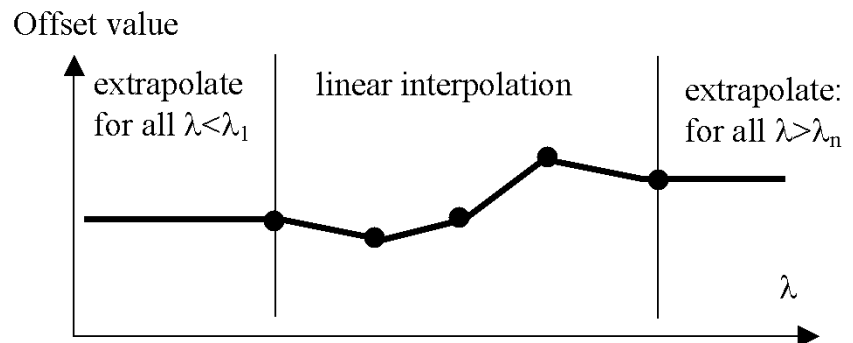

Figure 6 Extrapolation and interpolation of attenuator module λ offset table

command:	:CONFigure[n][:CHANnel[m]]:OFFSet:WAVelength:STATe
syntax:	:CONFigure[n][:CHANnel[m]]:OFFSet:WAVelength:STATe<wsp>OFF(0) ON(1)
description:	Specifies whether the attenuator uses its λ offset table to compensate for wavelength dependent losses in the the test set-up. This table contains, for each wavelength specified, the additional power offset to be applied. This command does not affect the module's internal enviromental temperature and optical wavelength compensation, which remain active.
parameters:	OFF or 0 The offset table is not used to compensate for wavelength dependent losses. ON or 1 The attenuator adds the appropriate value from its λ offset table to the global power offset.
response:	none
example:	CONF1:OFFS:WAV:STAT ON
affects:	All attenuator modules.

command:	:CONFigure[n][:CHANnel[m]]:OFFSet:WAVelength:STATe?
syntax:	:CONFigure[n][:CHANnel[m]]:OFFSet:WAVelength:STATe?
description:	Queries whether the attenuator uses power values from its λ offset table .
parameters:	none
response:	<i>boolean</i> 0 The offset table is not used. 1 The attenuator uses its λ offset table.
example:	CONF1:OFFS:WAV:STAT? → 0<END>
affects:	All attenuator modules.

command:	:CONFigure[n][:CHANnel[m]]:OFFSet:WAVelength:VALue
syntax:	:CONFigure[n][:CHANnel[m]]:OFFSet:WAVelength:VALue<wsp><lambda>[PM NM UM MM M],<offset[DB]> TOREF
description:	Adds a value pair (wavelength; offset) to the offset table, or overwrites an existing value pair. The offset table entries are ordered from shortest to longest wavelength.
parameters:	<lambda> The wavelength for the offset table entry, in m <offset> The power offset to be applied at <lambda>. To query the current power value measured by attenuator with power control see page 87 (Fetch) and page 90 (Read). TOREF Calculates the difference between the power measured by an external powermeter (hosted in the same mainframe) and the power measured by the attenuator module's integrated powermeter, and stores it as the offset. $P_{\text{Offset}}(\lambda)(\text{dB}) = P_{\text{att}}(\text{dBm}) - P_{\text{ext}}(\text{dBm})$ See: ":CONFigure[n][:CHANnel[m]]:OFFSet:WAVelength:REFeRence" on page 161 (Attenuator modules with power control only).
response:	none
example:	CONF1:OFFS:WAV:VAL +1.55000000E-006,TOREF
affects:	All attenuator modules (TOREF applicable to attenuator modules with power control only).

command:	:CONFigure[n][:CHANnel[m]]:OFFSet:WAVelength:REFeRence
syntax:	:CONFigure[n][:CHANnel[m]]:OFFSet:WAVelength:REFeRence<wsp><slot>,<channel>
description:	Specifies the slot and channel of the external powermeter (hosted in the same mainframe as the attenuator module) used by TOREF. See: ":CONFigure[n][:CHANnel[m]]:OFFSet:WAVelength:VALue" on page 161
parameters:	<slot> Slot number of the powermeter. <channel> Channel number of the powermeter.
response:	none
example:	CONF1:OFFS:WAV:REF 4,2
affects:	Attenuator modules with power control.

command:	:CONFigure[n][:CHANnel[m]]:OFFSet:WAVelength:REFerence?
syntax:	:CONFigure[n][:CHANnel[m]]:OFFSet:WAVelength:REFerence?
description:	Queries the currently selected slot and channel of the external powermeter (hosted in the same mainframe as the attenuator module) used by TOREF. See: “:CONFigure[n][:CHANnel[m]]:OFFSet:WAVelength:VALue” on page 161
parameters:	none
response:	the slot and channel of the external powermeter as <i>integer</i> values.
example:	CONF1:OFFS:WAV:REF? → +2,+1<END>
affects:	Attenuator modules with power control.

command:	:CONFigure[n][:CHANnel[m]]:OFFSet:WAVelength:VALue:WAVelength?
syntax:	:CONFigure[n][:CHANnel[m]]:OFFSet:WAVelength:VALue:WAVelength?<wsp><index>
description:	Queries a wavelength value from its position, or index, in the offset table. Offset table entries are ordered from shortest to longest wavelength. The first index number = 1.
parameters:	<index> The position of the wavelength value in the offset table.
response:	<i>4 byte Intel floating point; the wavelength in meters</i>
example:	CONF1:OFFS:WAV:VAL:WAV? 1 → +1.55000000E-006<END>
affects:	All attenuator modules.

command:	:CONFigure[n][:CHANnel[m]]:OFFSet:WAVelength:VALue:OFFSet?
syntax:	:CONFigure[n][:CHANnel[m]]:OFFSet:WAVelength:VALue:OFFSet?<wsp><index wavelength [PM NM UM MM M],>
description:	Queries an offset value from the position, or index, of the associated wavelength in the offset table. Offset table entries are ordered from shortest to longest wavelength. The first index number =1. Or: Queries the offset applied for a particular wavelength.
parameters:	<index> The position of the value pair (wavelength; offset) in the offset table. <wavelength> The wavelength for the offset table entry, in m
response:	<i>4 byte Intel floating point; the offset</i>
example:	CONF1:OFFS:WAV:VAL:OFFS? 1 → 2
affects:	All attenuator modules.

command:	:CONFigure[n][:CHANnel[m]]:OFFSet:WAVelength:VALue:PAIR?
syntax:	:CONFigure[n][:CHANnel[m]]:OFFSet:WAVelength:VALue:PAIR?<wsp><index wavelength[PM NM UM MM M],>
description:	Queries an offset value pair (wavelength:offset) from the position, or index, of the associated wavelength in the offset table. Offset table entries are ordered from shortest to longest wavelength. Or: Queries the offset value pair (wavelength:offset) applied for the specified wavelength.
parameters:	<index> The position of the wavelength; offset value pair in the offset table. <wavelength> The wavelength for the offset table entry, in m
response:	<i>char\$ in SCPI block format (Intel byte order); wavelength:offset</i>
example:	CONF1:OFFS:WAV:VAL:PAIR? 1 → "+1.55000000E-006:2"
affects:	All attenuator modules.

command:	:CONFigure[n][:CHANnel[m]]:OFFSet:WAVelength:VALue:DELeTe
syntax:	:CONFigure[n][:CHANnel[m]]:OFFSet:WAVelength:VALue:DELeTe<wsp><index wavelength[PM NM UM MM M],>
description:	Deletes an offset value pair (wavelength:offset) from the position, or index, of the associated wavelength in the offset table. Offset table entries are ordered from shortest to longest wavelength. Or: Deletes the offset value pair (wavelength:offset) associated with the specified wavelength.
NOTE	Deleting a value pair decrements the index value of every subsequent value pair by 1. When using this command, you may prefer to work from large to small index values.
parameters:	<index> The position of the wavelength:offset value pair in the offset table. <wavelength> The wavelength for the offset table entry, in m
response:	<i>none</i>
example:	CONF1:OFFS:WAV:VAL:DEL 1
affects:	All attenuator modules.

command:	:CONFigure[n][:CHANnel[m]]:OFFSet:WAVelength:VALue:DELeTe:ALL
syntax:	:CONFigure[n][:CHANnel[m]]:OFFSet:WAVelength:VALue:DELeTe:ALL
CAUTION	<i>This command clears the offset table!</i>
description:	Deletes every value pair (wavelength:offset) from the offset table.
parameters:	<i>none</i>
response:	<i>none</i>
example:	CONF1:OFFS:WAV:VAL:DEL:ALL
affects:	All attenuator modules.

command:	:CONFigure[n][:CHANnel[m]]:OFFSet:WAVelength:TABLE?
syntax:	:CONFigure[n][:CHANnel[m]]:OFFSet:WAVelength:TABLE?
description:	Queries the complete the offset table.
parameters:	none
response:	<i>SCPI binary block format format (Intel byte order); wavelength:offset pairs in ascending order.</i> Each value pair is transferred as 12 bytes; 8 bytes represent the wavelength, 4 bytes represent the offset.
example:	CONF1:OFFS:WAV:TAB? → binary block interpreted as, for example: 1.55e-6 12 1.7e-6 3.4
affects:	All attenuator modules.

command:	:CONFigure[n][:CHANnel[m]]:OFFSet:WAVelength:TABLE:SIZE?
syntax:	:CONFigure[n][:CHANnel[m]]:OFFSet:WAVelength:TABLE:SIZE?<wsp>MAX MIN
description:	Without optional parameter, queries the size of the offset table.
parameters:	MAX Queries the maximum size of the offset table. (available flash memory → 1000 entries) MIN Queries the minimum size of the offset table. (should → 0)
response:	<i>4 byte unsigned integer; offset table size.</i>
example:	CONF1:OFFS:WAV:TAB:SIZE? → 50
affects:	All attenuator modules.

Compatibility of the 81560A/1A/6A/7A modular attenuator family to the 8156A attenuator

The 81560A/1A/6A/7A modular attenuator family is intended to be SCPI compatible with the 8156A attenuator but, because the modular attenuator family is part of a platform concept, there are some compatibility limitations. This section describes the differences between the SCPI syntax and the command semantic and how to deal with them.

NOTE

The page numbers in brackets refer to pages in the Agilent Technologies 8156A Attenuator Operating and Programming Guide, Second Edition, May 2000 with part number 08156-91011:E0500.

Slot Numbers

INPUT and OUPUT SCPI commands (page 106-114) are used to access the functionality of the 8156A Attenuator. The 816xA/B mainframes are able to host a number of modules, so a slot identifier is needed. This slot identifier was not required by the 8156A attenuator. Simply substitute INPutn for INPut, and OUTPutn for OUTPut, where n is the slot number of your attenuator module.

Example1: Setting the attenuation

```
8156A:INP:ATT 10 dB
```

```
8156x:INP2:ATT 10 dB
```

(when the attenuator is hosted in Slot 2)

Example2: Setting the output power

```
8156A:OUTP:POW 10 dBm
```

```
8156x:OUTP2:POW 10 dBm
```

(when the attenuator is hosted in Slot 2)

If you forget to enter the slot number, one of the following error messages is placed in the SCPI error queue:

```
-303,"Module slot empty or slot / channel invalid"
```

```
-301,"Module doesn't support this command (StatCmdUnknown)"
```

TIP: Query the SCPI error queue using SYST:ERR?

TIP: You can use INPut commands without a slot number if the 81560A/1A/6A/7A module is hosted by Slot 1. An INPut command is applied to Slot 1 by default.

Command Semantic

All the INPut and OUTPut commands applicable to the 8156A attenuator are also supported by the 81560A/1A/6A/7A modular attenuator family. In addition, the 81560A/1A/6A/7A modular attenuator family supports new commands to access its new features. To support these new features, and improve the usability of the instrument, the meaning (the semantic) of some existing commands has changed. This section lists all commands already available to the 8156A attenuator, notes whether the semantic of the command has changed, and where applicable, suggests how to handle the change.

Table 7 Comparison of command semantics between 8156A attenuator and 8156xA modular attenuator family.

Command	Comment
INPut:ATTenuation	No change.
INPut:ATTenuation?	No change.
INPut:LCMode	No longer supported. Use the wavelength dependent offset command.
INPut:LCMode?	No longer supported. Use the wavelength dependent offset command.
INPut:OFFSet	No change.
INPut:OFFSet?	No change.
INPut:OFFSet:DISPlay	No change.
INPut:WAVelength	No change.
OUTPut:APMode	<p>The 8156A uses this command to calculate a base power level while the instrument switches to another mode. This behavior is replaced by a mechanism that is easier to use.</p> <p>To calculate a power level at the device under test, formerly known as <i>through</i> power, the 81560A and 81561A attenuator modules use a reference power. This reference power can be modified either via the user interface or by using the SCPI command OUTPut:POWer:REFErence. The power is calculated from the attenuation and the reference power using this formula:</p> $P_{\text{set}} \text{ (dBm)} = P_{\text{ref}} \text{ (dBm)} - \alpha \text{ (dB)}$ <p>The 81566A and 81567A attenuator modules do not need a base power level because they are able to measure the output power directly.</p> <p>Despite these new features, the 8156x modular attenuator family supports this command, but only to address compatibility issues. The command only sets an internal flag, which can be read using OUTPut:APMode?. You are free to choose between adjusting the output power or adjusting the attenuation factor.</p>

Table 7 Comparison of command semantics between 8156A attenuator and 8156xA modular attenuator family.

Command	Comment
OUTPut:APMode?	It is now possible to adjust both power and attenuation without changing the mode, so this command is supported only to address compatibility issues. This query returns whether power (1) or attenuation (0) was changed last. All other actions have no effect on this internal flag.
OUTPut:POWer	Except that the base power level is determined in another way (see OUTPut:AP-Mode), there is no change to the semantic of this command.
OUTPut:POWer?	No change.
OUTPut:STATe	No change.
OUTPut:STATe?	No change.
OUTPut:STATe:APOWeron	No change.
OUTPut:STATe:APOWeron?	No change.

Display and System Commands

The commands to adjust the instrument display (page 104ff) and query the error queue (page 122) also work with the 816xA/B platform:

DISPlay:BRIGhtness

DISPlay:ENABle

SYSTem:ERRor?

IEEE Commands

Every SCPI compatible measurement instrument implements a subset of the IEEE SCPI command set. The 8156A attenuator and the 81560A/1A/6A/7A attenuator family use almost the same subset. The following IEEE commands are available when using the 8156A but not available when using the 81560A/1A/6A/7A modules (page 93ff):

*RCLRecover parameter setup

*SAVSave parameter setup

*SRE and *SRE?Status request register

Status Commands

The instrument status model can be controlled, and its current state queried, using commands from the SCPI STATus subtree. All the STATus commands available for the 8156A attenuator are supported by the 81560A/1A/6A/7A modular attenuator family except:

STATus:OPERation:PTRansition

STATus:OPERation:NTRansition

STATus:QUEStionable:PTRansition

STATus:QUEStionable:NTRansition

There are new status bits available to query the current modular attenuator state.

User Calibration Data

The user calibration mode of the 8156A overrides the attenuator's built-in wavelength calibration table, so allowing user defined wavelength compensation. Since the 81560A/1A/6A/7A modular attenuator family features an improved factory calibration process, so this user calibration feature (page 123) is not supported.

The 81560A/1A/6A/7A modular attenuator family includes a user configurable offset function. If you enable this feature, the module's internal wavelength compensation remains active and you are able to compensate for additional external wavelength-dependent losses within the measurement setup by creating a wavelength/offset table. For additional information, refer to our Application Note "Variable Optical Attenuator in BER Test Applications", part number 5988-3159EN.

Signal Routing

The commands in this section allow you to control Agilent 8159x Optical Switch modules

command:	:ROUTE[n][:CHANnel[m]]
syntax:	:ROUTE[n][:CHANnel[m]]<wsp><channel_list>
description:	Sets the channel route between two ports.
NOTE	When you use switches with dependent connections (e.g. the 2x2 switch), it is possible that one route configuration automatically changes another connection!
parameters:	n: the slot number of the switch module m: the switch channel within the selected switch module. e.g. for dual 1 x 2 module m = 1 for switch 1; m = 2 for switch 2 channel_list the route between left and right ports. channel_list format: [A....Z],[1.....n]
response:	If an invalid route is selected the following error message is returned - "StatParamError"
example:	route3:chan1 A,2 (module in slot 3,channel 1, connect port A with port 2)
affects:	All switch modules

command:	:ROUTE[n][:CHANnel[m]]?
syntax:	:ROUTE[n][:CHANnel[m]]<wsp><channel_list>
description:	Queries the current channel route of the switch for a specific module and switch channel.
parameters:	n: the slot number of the switch module m: the switch channel within the selected switch module. Default value is 1.
response:	[A....Z],[1.....n];[A....Z],[1.....n] as a text string. "," separates input and output ports of a specific connection. ";" separates parallel connections (as used in 2x2 switch).
example:	route3:chan1? → A,1 simple 1xN switch route2:chan1? → A,2;B,1 (2x2 crossover switch in crossover config).
affects:	All switch modules

command:	:ROUTe[n][:CHANnel[m]]:CONFig?
syntax:	:ROUTe[n][:CHANnel[m]]:CONFig?
description:	Queries the switch configuration of the instrument. For each channel, the minimum and maximum channel number of each port is given.
	NOTE
parameters:	none
response:	<j>,<k>;<l>,<m> as text string where: <j> is the first port character on the left <k> is the last port character on the left <l> is the minimum port number on the right <m> is the maximum port number on the right
example:	rou2:conf? → A,B;1,2 (2 left and 2 right ports)
affects:	All switch modules

command:	:ROUTe[n][:CHANnel[m]]:CONFig:ROUTe?
syntax:	:ROUTe[n][:CHANnel[m]]:CONFig:ROUTe?
description:	Queries the allowed switch routes of an instrument.
	NOTE
parameters:	none
response:	[A.....Z],[1.....n];[A.....Z],[1.....n].[A.....Z],[1.....n] as a text string. "," separates input and output ports of a single connection. ";" separates parallel connections "." separates possible switch states
example:	rou2:conf:rout? → A,1;B,2.A,2;B,1 2x2 x-over switcch: state 1: When A to 1 then B to 2nd connection (straight) state 2: When A to 2 then B to 1st connection (cross-over)
affects:	All switch modules

Triggering - The TRIGger Subsystem

The TRIGger Subsystem allows you to configure how the instrument reacts to incoming or outgoing triggers.

Table 8 Triggering and Power Measurements

Hardware Triggering	Trigger Rearming	Software Triggering		Data Acquisition Functions	
		init:imm	init:cont	sens:func:stat	
trig:inp	trig:inp:rearm			MINMax	LOGGing STABility
IGNore	-	One power measurement is performed.	Automatically performs power measurements.		Automatically performs power measurements until the function is finished.
SMEasure	ON	Every hardware trigger starts a new power measurement.			Every hardware trigger starts a new power measurement until the function is finished.
CMEasure	ON				
SMEasure	OFF	The first hardware trigger starts a new power measurement. Further hardware triggers are ignored until you send trig:inp:rearm again.			Every hardware trigger starts a new power measurement until the function is finished.
CMEasure	OFF				
					The first hardware trigger starts the function. Subsequent power measurements are automatically performed until the function is finished.

Table 9 Generating Output Triggers from Power Measurements

Hardware Triggering	Trigger Rearming	Software Triggering		Data Acquisition Functions	
		init:imm	init:cont	sens:func:stat	
trig:outp	trig:outp:rearm			MINMax	LOGGing STABility
DISabled	-	An output trigger will never be generated.			
AVGover	ON	An output trigger is generated for every new power measurement when the averaging time period finishes.			
MEASure	ON	An output trigger is generated for every new power measurement when the averaging time period begins.			
AVGover	OFF	An output trigger is generated when the averaging time period of the first power measurement finishes. A further hardware output trigger cannot be generated until you send trig:outp:rearm.		An output trigger is generated for every new power measurement when the averaging time period finishes. Applies for all subsequent data acquisition functions.	
MEASure	OFF	An output trigger is generated when the averaging time period of the first power measurement begins. A further hardware output trigger cannot be generated until you send trig:outp:rearm.		An output trigger is generated for every new power measurement when the averaging time period begins. Applies for all subsequent data acquisition functions.	

command:	:TRIGger
syntax:	:TRIGger<wsp>NODEA 1 NODEB 2
description:	Generates a hardware trigger.
parameters:	1 or NODEA: Is identical to a trigger at the Input Trigger Connector. 2 or NODEB: Generates trigger at the Output Trigger Connector.
NOTE	A hardware trigger cannot be effective in the DISabled triggering mode but can be effective in DEFault, PASSthrough or LOOPback triggering modes, see <i>":TRIGger:CONFIguration"</i> on page 177 for information on triggering modes.
NOTE	<i>":TRIGger"</i> on page 179 describes the :TRIGger command for advanced users using <i>":TRIGger:CONFIguration:EXTended"</i> on page 179.
response:	none
example:	trig 1

command:	:TRIGger[n][:CHANnel[m]]:INPut
syntax:	:TRIGger[n][:CHANnel[m]]:INPut<wsp><trigger response>
description:	Sets the incoming trigger response and arms the module.
parameters:	<p>IGNore: Ignore incoming trigger.</p> <p>SMEasure: Start a single measurement. If a measurement function is active, see “:SENSe[n][:CHANnel[m]]:FUNction:STATe” on page 100, one sample is performed and the result is stored in the data array, see “:SENSe[n][:CHANnel[m]]:FUNction:RESult?” on page 97.</p> <p>CMEasure: Start a complete measurement. If a measurement function is active, see “:SENSe[n][:CHANnel[m]]:FUNction:STATe” on page 100, a complete measurement function is performed.</p> <p>NEXTstep: Perform next step of a stepped sweep.</p> <p>SWStart: Start a sweep cycle.</p>
NOTE	<p>You must prearm a wavelength sweep or a measurement function before an action can be triggered:</p> <p>First, set the incoming trigger response.</p> <p>Then:</p> <ul style="list-style-type: none"> • prearm a wavelength sweep using “[:SOURce[n]][:CHANnel[m]]:WAVelength:SWEEp:[STATe]” on page 145. The wavelength of the tunable laser module is set to the start wavelength of the sweep. • or prearm a measurement function using “:SENSe[n][:CHANnel[m]]:FUNction:STATe” on page 100. <p>NOTE: If a trigger signal arrives at the Input Trigger Connector at the same time that the :SENSe[n][:CHANnel[m]]:FUNction:STATe command is executed, the first measurement value is invalid. You should always discard the first measurement value in this case.</p> <p>The module performs the appropriate action when it is triggered.</p>
response:	none
example:	trig1:inp ign
affects:	All Agilent 8163A/B series power meter modules, Agilent 8161x series return loss modules, and attenuators with power control.
NOTE	If you use the Agilent 816x VXIplug&play Instrument Driver, you can trigger power measurements using HP 8153A Series power meters.
dual sensors:	Can only be sent to master channel, slave channel is also affected.

command:	:TRIGger[n][:CHANnel[m]]:INPut?
syntax:	:TRIGger[n][:CHANnel[m]]:INPut?
description:	Returns the incoming trigger response.
parameters:	none
response:	<p>IGNore: Ignore incoming trigger.</p> <p>SMEasure: Start a single measurement. If a measurement function is active, see “:SENSe[n][:CHANnel[m]]:FUNction:STATe” on page 100, one sample is performed and the result is stored in the data array, see “:SENSe[n][:CHANnel[m]]:FUNction:RESult?” on page 97.</p> <p>CMEasure: Start a complete measurement. If a measurement function is active, see “:SENSe[n][:CHANnel[m]]:FUNction:STATe” on page 100, a complete measurement function is performed.</p> <p>NEXTstep: Perform next step of a stepped sweep.</p> <p>SWStart: Start a sweep.</p>
example:	trig1:inp? → ign<END>
affects:	All tunable laser modules, power meters, and return loss modules, and attenuators with power control.
dual sensors:	Can only be sent to master channel, slave channel parameters are identical.

command:	:TRIGger[n][:CHANnel[m]]:INPut:REARm
syntax:	:TRIGger[n][:CHANnel[m]]:INPut:REARm<wsp>OFF ON 0 1
description:	Sets the arming response of a channel to an incoming trigger.
NOTE	See Table Table 8 , for information on how this command affects triggering power measurements.
parameters:	A <i>boolean</i> value: OFF or 0: trigger rearming disabled ON or 1: trigger rearming enabled (default)
NOTE	If you return to Local control, all modules return to the default setting.
response:	none
example:	trig1:inp:rearm 0
affects:	All Agilent 8163A/B series power meter modules, and Agilent 8161x series return loss modules.
dual sensors:	Can only be sent to master channel, slave channel is also affected.

command:	:TRIGger[n][:CHANnel[m]]:INPut:REARm?
syntax:	:TRIGger[n][:CHANnel[m]]:INPut:REARm?
description:	Returns the arming response of a channel to an incoming trigger.
parameters:	none
response:	A <i>boolean</i> value: 0: trigger rearming disabled 1: trigger rearming enabled (default)
example:	trig1:inp:rearm? → 0<END>
affects:	All Agilent 8163A/B series power meter modules, and Agilent 8161x series return loss modules.
dual sensors:	Can only be sent to master channel, slave channel parameters are identical.

command:	:TRIGger[n][:CHANnel[m]]:OFFSet
syntax:	:TRIGger[n][:CHANnel[m]]:OFFSet <value>
description:	Sets the number of incoming triggers received before data logging begins.
parameters:	<value> - an integer value. (maximum possible value is 1e+9)
response:	none
example:	trig1:offs 5
affects:	All Agilent 81636B and 81637B series power meter modules.

command:	:TRIGger[n][:CHANnel[m]]:OFFSet?
syntax:	:TRIGger[n][:CHANnel[m]]:OFFSet?
description:	Returns the number of incoming triggers received before data logging begins.
parameters:	none
response:	an integer value.
example:	trig1:offs? → 5<END>
affects:	All Agilent 81636B and 81637B series power meter modules.

command:	:TRIGger[<i>n</i>][:CHANnel[<i>m</i>]:]OUTPut
syntax:	:TRIGger[<i>n</i>][:CHANnel[<i>m</i>]:]OUTPut
description:	Specifies when an output trigger is generated and arms the module.
parameters:	<p>DISabled: Never.</p> <p>AVGover: When averaging time period finishes.</p> <p>MEASure: When averaging time period begins.</p> <p>MODulation: For every leading edge of a digitally-modulated (TTL) signal</p> <p>STFinished: When a sweep step finishes.</p> <p>SWFinished: When sweep cycle finishes.</p> <p>SWSTarted: When a sweep cycle starts.</p>
response:	none
example:	trig1:outp dis
affects:	All tunable laser modules, Agilent 8163A/B series power meters, and Agilent 8161x series return loss modules.
dual sensors:	Can only be sent to master channel, slave channel is also affected.
NOTE	In continuous mode, wav:swe:step:[widt] is used for triggering, see page 146.

command:	:TRIGger[<i>n</i>][:CHANnel[<i>m</i>]:]OUTPut?
syntax:	:TRIGger[<i>n</i>][:CHANnel[<i>m</i>]:]OUTPut?
description:	Returns the condition that causes an output trigger.
parameters:	none
response:	<p>DISabled: Never.</p> <p>AVGover: When averaging time period finishes.</p> <p>MEASure: When averaging time period begins.</p> <p>MODulation: For every leading edge of a digitally-modulated (TTL) signal</p> <p>STFinished: When a sweep step finishes.</p> <p>SWFinished: When sweep cycle finishes.</p> <p>SWSTarted: When a sweep cycle starts.</p>
example:	trig1:outp? → dis<END>
affects:	All tunable laser modules, Agilent 8163A/B series power meters, and Agilent 8161x series return loss modules.
dual sensors:	Can only be sent to master channel, slave channel parameters are identical.

command:	:TRIGger[n][:CHANnel[m]]:OUTPut:REARm
syntax:	:TRIGger[n][:CHANnel[m]]:OUTPut:REARm<wsp>OFF ON 0 1
description:	Sets the arming response of a channel to an outgoing trigger.
NOTE	See Table Table 9 , for information on how this command affects the generation of output triggers using power measurements.
parameters:	A <i>boolean</i> value: OFF or 0: trigger rearming disabled ON or 1: trigger rearming enabled (default)
NOTE	If you return to Local control, all modules return to the default setting.
response:	none
example:	trig1:outp:rearm 1
affects:	All Agilent 8163A/B series power meters, and Agilent 8161x series return loss modules.
dual sensors:	Can only be sent to master channel, slave channel is also affected.

command:	:TRIGger[n][:CHANnel[m]]:OUTPut:REARm?
syntax:	:TRIGger[n][:CHANnel[m]]:OUTPut:REARm?
description:	Returns the arming response of a channel to an outgoing trigger.
parameters:	none
response:	A <i>boolean</i> value: 0: trigger rearming disabled (default) 1: trigger rearming enabled.
example:	trig1:outp:rearm? → 0<END>
affects:	All Agilent 8163A/B series power meters, and Agilent 8161x series return loss modules.
dual sensors:	Can only be sent to master channel, slave channel parameters are identical.

command:	:TRIGger:CONFIguration
syntax:	:TRIGger:CONFIguration<wsp><triggering mode>
description:	Sets the hardware trigger configuration with regard to Output and Input Trigger Connectors.
parameters:	0 or DISabled: Trigger connectors are disabled. 1 or DEFault: The Input Trigger Connector is activated, the incoming trigger response for each slot “:TRIGger[n][:CHANnel[m]]:INPut” on page 173 determines how each slot responds to an incoming trigger, all slot events (see “:TRIGger[n][:CHANnel[m]]:OUTPut” on page 176) can trigger the Output Trigger Connector. 2 or PASSthrough: The same as DEFault but a trigger at the Input Trigger Connector generates a trigger at the Output Trigger Connector automatically. 3 or LOOPback: The same as DEFault but a trigger at the Output Trigger Connector generates a trigger at the Input Trigger Connector automatically.
response:	none
example:	trig:conf dis

command:	:TRIGger:CONFIguration?
syntax:	:TRIGger:CONFIguration?
description:	Returns the hardware trigger configuration.
parameters:	none
response:	<p>DIS: Trigger connectors are disabled.</p> <p>DEF: The Input Trigger Connector is activated, the incoming trigger response for each slot “:TRIGger[n]:CHANnel[m]:INPut” on page 173 determines how each slot responds to an incoming trigger, all slot events (see “:TRIGger[n]:CHANnel[m]:OUTPut” on page 176) can trigger the Output Trigger Connector.</p> <p>PASS: The same as DEFault but a trigger at the Input Trigger Connector generates a trigger at the Output Trigger Connector automatically.</p> <p>LOOP: The same as DEFault but a trigger at the Output Trigger Connector generates a trigger at the Input Trigger Connector automatically.</p> <p>CUSTOM: A custom configuration is active using either the command “:TRIGger:CONFIguration:EXTended” on page 179 or the Agilent 816x VXiplug&play Instrument Driver. See “The Agilent 816x VXiplug&play Instrument Driver” on page 213.</p>
example:	trig:conf? → DEF<END>

command:	:TRIGger:CONFIguration:FPEDal
syntax:	:TRIGger:CONFIguration:FPEDal<wsp>OFF ON 0 1
description:	Enables or disables the Input Trigger connector to be triggered using a Foot Pedal.
parameters:	A <i>boolean</i> value: OFF or 0: foot pedal disabled (default) ON or 1: foot pedal enabled
response:	none
example:	trig:conf? → DEF<END>

command:	:TRIGger:CONFIguration:FPEDal?
syntax:	:TRIGger:CONFIguration:FPEDal?
description:	Returns whether the Input Trigger connector can be triggered using a Foot Pedal.
parameters:	none
response:	A <i>boolean</i> value: 0: foot pedal disabled 1: foot pedal enabled
example:	trig:conf? → DEF<END>

Extended Trigger Configuration

This section includes information for advanced users about how to customize your use of the trigger system.

You can configure the outputs and inputs from two nodes, Node A and Node B. See Figure 7 on page 180 for more information on Node A and Node B. You can configure these nodes to be triggered by certain events and for these nodes to trigger particular actions.

command:	:TRIGger
syntax:	:TRIGger<wsp>NODEA 1 NODEB 2
description:	Generates a hardware trigger.
parameters:	1 or NODEA: Generates trigger at Node A. 2 or NODEB: Generates trigger at Node B.
	Use <i>“:TRIGger:CONFIguration:EXTended”</i> on page 179 to configure Node A and Node B.
NOTE	<i>“:TRIGger”</i> on page 172 describes the :TRIGger command for basic users.
response:	none
example:	trig 1

command:	:TRIGger:CONFIguration:EXTended
syntax:	:TRIGger:CONFIguration:EXTended<wsp><Node A Input Config.>, <Node B Input Config.>,<Output Matrix Config.>
description:	Sets the extended hardware trigger configuration.
parameters:	Node A Input Configuration: A 32-bit unsigned integer , see below. Node B Input Configuration: A 32-bit unsigned integer , see below. Output Matrix Configuration: A 32-bit unsigned integer , see below.
response:	none
example:	trig:conf:ext 0,0,0

command:	:TRIGger:CONFIguration:EXTended?
syntax:	:TRIGger:CONFIguration:EXTended?
description:	Returns the extended hardware trigger configuration.
parameters:	none
response:	Node A Input Configuration: A 32-bit unsigned integer , see below. Node B Input Configuration: A 32-bit unsigned integer , see below. Output Matrix Configuration: A 32-bit unsigned integer , see below.
example:	trig:conf:ext? → +0,+0,+0<END>

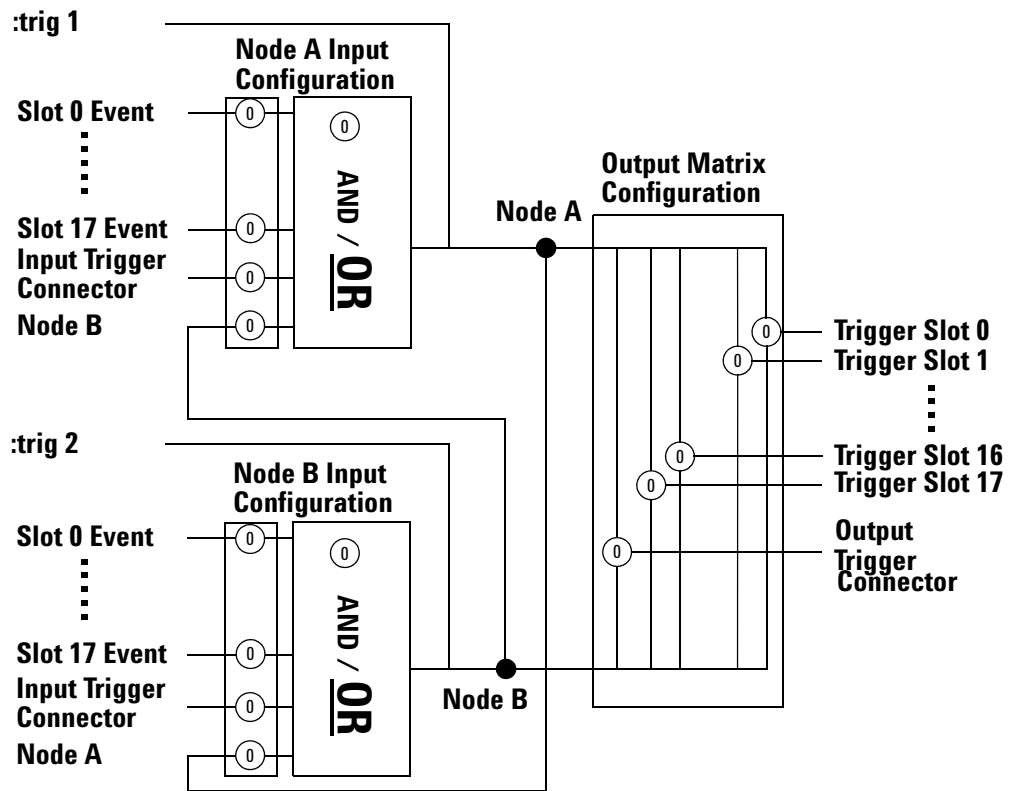

Bits set in Node A/B Input Configuration determine the conditions that can cause a trigger at Node A/B.

Bits set in Output Matrix Configuration determine whether Node A OR Node B triggers particular module slots or generates an output trigger at the Output Trigger Connector.

“:TRIGger[n][:CHANnel[m]]:OUTPut” explains how slot events can generate triggers.

“:TRIGger[n][:CHANnel[m]]:INPut” explains how a slot responds to an incoming trigger.

“:TRIGger” generates a trigger at Node A or Node B directly.

Figure 7 Extended Trigger Configuration

Node A Input Configuration This 32-bit unsigned integer determines how inputs to Node A are generated.		
Bit	Mnemonic	Hexadecimal
31	Logic: 0 for OR, 1 for AND	#H80000000
30	Input Trigger Connector: 0 - Inactive, 1 - Trigger at Input Trigger Connector can trigger Node A	#H40000000
29	Node B: 0 - Inactive, 1 - Trigger at Node B can trigger Node A	#H20000000
18-28	Not used.	0
17	Slot 17: 0 - Inactive, 1 - Event at slot 17 can trigger Node A	#H20000
16	Slot 16: 0 - Inactive, 1 - Event at slot 16 can trigger Node A	#H10000
⋮	⋮	
2	Slot 2: 0 - Inactive, 1 - Event at slot 2 can trigger Node A	#H4
1	Slot 1: 0 - Inactive, 1 - Event at slot 1 can trigger Node A	#H2
0	Slot 0: 0 - Inactive, 1 - Event at slot 0 can trigger Node A ":TRIGger[n]:CHANnel[m]:OUTPut" on page 176 explains how slot events can generate triggers.	#H1

Node B Input Configuration This 32-bit unsigned integer determines how inputs to Node B are generated.		
Bit	Mnemonic	Hexadecimal
31	Logic: 0 for OR, 1 for AND	#H80000000
30	Input Trigger Connector: 0 - Inactive, 1 - Trigger at Input Trigger Connector can trigger Node B	#H40000000
29	Node A: 0 - Inactive, 1 - Trigger at Node A can trigger Node B	#H20000000
18-28	Not used.	0
17	Slot 17: 0 - Inactive, 1 - Event at slot 17 can trigger Node B	#H20000
16	Slot 16: 0 - Inactive, 1 - Event at slot 16 can trigger Node B	#H10000
⋮	⋮	
2	Slot 2: 0 - Inactive, 1 - Event at slot 2 can trigger Node B	#H4
1	Slot 1: 0 - Inactive, 1 - Event at slot 1 can trigger Node B	#H2
0	Slot 0: 0 - Inactive, 1 - Event at slot 0 can trigger Node B ":TRIGger[n]:CHANnel[m]:OUTPut" on page 176 explains how slot events can generate triggers.	#H1

Output Matrix Configuration		
This 32-bit unsigned integer lets you choose Node A OR Node B to trigger each of the following: <ul style="list-style-type: none"> • the Output Trigger Connector or • individual module slots. 		
Bit	Mnemonic	Hexadecimal
31	Not used	0
30	Output Trigger Connector: 0 - a trigger at Node A is switched to the Output Trigger Connector, 1 - a trigger at Node B is switched to the Output Trigger Connector	#H40000000
18-29	Not used	
17	Slot 17: 0 - Node A triggers slot 17, 1 - Node B triggers slot 17	0
16	Slot 16: 0 - Node A triggers slot 16, 1 - Node B triggers slot 16	#H20000
⋮	⋮	#H10000
2	Slot 2: 0 - Node A triggers slot 2, 1 - Node B triggers slot 2	
1	Slot 1: 0 - Node A triggers slot 1, 1 - Node B triggers slot 1	#H4
0	Slot 0: 0 - Node A triggers slot 0, 1 - Node B triggers slot 0 “:TRIGger[n][:CHANnel[m]];INPut” on page 173 explains how a slot responds to an incoming trigger.	#H2 #H1

Extended Trigger Configuration Example

The short example below demonstrates how to use extended triggering configuration to make tunable laser source modules sweep simultaneously. Setup your mainframe with two Agilent 81689A modules in slots 1 and 2. The example below presumes you set up identical stepped sweeps for both modules, for example, by pressing *PRESET*.

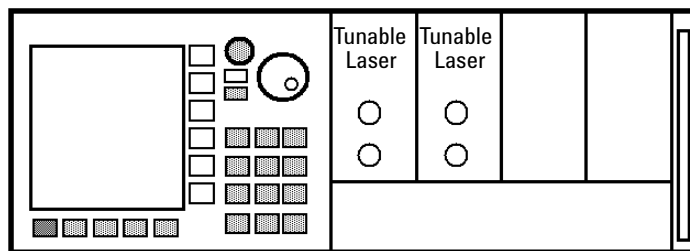

Figure 8 Setup for Extended Trigger Configuration Example

```
trig:conf:ext #H2,#H0,#H0
trig2:outp dis
trig2:inp next
sour2:wav:swe star
trig1:outp stf
trig1:inp ign
sour1:wav:swe star
```

trig:conf:ext #H2,#H0,#H0 is described by Figure 4-1 and sets one bit:

- for Node A Input Configuration:
 - Bit 1 - an event at slot 1 can trigger Node A. As trig1:outp stf is set, Node A can be triggered if a sweep step finishes for a tunable laser module installed in slot 1.

The following explanation explains the sequence with which actions are triggered.

- 1** sour2:wav:swe star arms the sweep for for the tunable laser module in slot 2. Because trig2:inp next is set, the module waits for a trigger until it performs the first step of the sweep.
- 2** sour1:wav:swe star commands the tunable laser module in slot 1 to start sweeping. Because trig1:inp ign is set, the module performs a sweep as normal.
- 3** When the module in slot 1 finishes a step, because trig1:outp stf is set, Node A is triggered.
- 4** Node A triggers all modules because the Output Matrix Configuration is set to zero. Node A triggers the tunable laser module in slot 2 to perform a sweep step because trig2:inp next is set.
- 5** The sequence starts again at step 3 and continues until the sweep ends.



5

Mass Storage, Display, and Print Functions

This chapter gives descriptions of commands that you can use when you want to change the instrument's display.

[Display Operations – The DISPlay Subsystem 186](#)

Display Operations – The DISPlay Subsystem

The DISPlay subsystem lets you control what you see on the instrument's display.

command:	:DISPlay:CONTRast
syntax:	:DISPlay:CONTRast<wsp><value>
description:	Controls the contrast of the display.
parameters:	An integer value in the range 0 to 100
response:	none
example:	disp:cont 50
affects:	Agilent 8163B Lightwave Multimeter and 8166B Lightwave Multichannel System

command:	:DISPlay:CONTRast?
syntax:	:DISPlay:CONTRast?
description:	Queries the contrast of the display.
parameters:	none
response:	An integer value in the range 0 to 100
example:	disp:cont? → +50<END>
affects:	Agilent 8163B Lightwave Multimeter and 8166B Lightwave Multichannel System

command:	:DISPlay:BRIGhtness
syntax:	:DISPlay:BRIGhtness<wsp><value>
description:	Controls the brightness of the display.
parameters:	An integer value in the range 0 to 100
response:	none
example:	disp:brig 75
affects:	Agilent 8163B Lightwave Multimeter and 8166B Lightwave Multichannel System - 8164A Lightwave Measurement System: only checks if the value equals 0. (0 -> display off, other values: display on)

command:	:DISPlay:BRIGhtness?
syntax:	:DISPlay:BRIGhtness?
description:	Queries the brightness of the display.
parameters:	none
response:	An integer value in the range 0 to 100
example:	disp:brig? → +75<END>
affects:	Agilent 8163B Lightwave Multimeter and 8166B Lightwave Multichannel System - 8164A Lightwave Measurement System: only checks if the value equals 0. (0 -> display off, other values: display on)

command:	:DISPlay:ENABLE
syntax:	:DISPlay:ENABLE<wsp>ON OFF 1 0
description:	Enables or disables the display. The display is cleared, and an appropriate message displayed. This setting may improve sweep performance.
parameters:	A <i>boolean</i> value: OFF or boolean 0 – switch off the display ON or boolean 1 – switch on the display
NOTE	If you press [LOCAL] softkey, the display is enabled automatically.
response:	none
example:	disp:enab 1

command:	:DISPlay:ENABLE?
syntax:	:DISPlay:ENABLE?
description:	Queries the state of the display.
parameters:	none
response:	A <i>boolean</i> value: 0 – the display is turned off 1 – the display is turned on
example:	disp:enab? → 1<END>

command:	:DISPlay:LOCKout
syntax:	:DISPlay:LOCKout<wsp>ON OFF 1 0
description:	Enables or Disables local operation.
parameters:	A <i>boolean</i> value: OFF or boolean 0 – local operation is disabled ON or boolean 1 – local operation is enabled.
response:	none
example:	disp:lock 1<END>

command:	:DISPlay:LOCKout?
syntax:	:DISPlay:LOCKout?
description:	Queries whether local operation is locked out.
parameters:	none
response:	A <i>boolean</i> value: 0 – local operation is disabled 1 – local operation is enabled.
example:	disp:lock → 1<END>

6

VISA Programming Examples

How to Use VISA Calls	190
How to Set up a Fixed Laser Source	192
How to Measure Power using FETCH and READ	195
How to Co-ordinate Two Modules	199
How Power Varies with Wavelength	203
How to Log Results	207

These programming examples are implemented using MS Developer Studio. Regardless of the programming environment you use, keep the following in mind:

- The resultant application is a "console application"
- Make sure the header files `visa.h` and `visatype.h` are included.
- Make sure the library path includes `visa32.lib`
- Ensure that the `PATH` environment variable allows loading `visa32.dll`.

The programming examples do not cover the full command set for the instruments. They are intended only as an introduction, how to program the instrument using VISA library calls.

The VISA calls used, are explained in detail in the VISA User's Guide.

NOTE

Never use VISA calls and the Agilent 816x VXI *plug&play* Instrument Driver in the same program.

TIP: Additional programming examples are provided on the Support Disk CD-ROM 08164-90BC4

How to Use VISA Calls

The following example demonstrates how to communicate using VISA calls. Also, the use of instrument identification commands is demonstrated.

```

#include <stdio.h>
#include <stdlib.h>
#include <visa.h>

/* This function checks and displays errors, using the error query of
the instrument;
Call this function after every command to make sure your commands
are correct */

void checkError(ViSession session, ViStatus err_status )
{
    ViStatus error;
    ViChar errMsg[256];
    /* queries what kind of error occurred */
    error = viQueryf(session,"%s\n","%t","SYST:ERR?",errMsg);
    /*if this command times out, a system error is probable;
    check the GPIB bus communication */
    if (error == VI_ERROR_TMO)
    {
        printf("System Error!\n") ;
        exit(1);
    }
    else
    {
        /* display the error number and the error message */
        if(errMsg[0] != '+')
            printf("error:%ld --> %s\n", err_status,errMsg) ;
    }
}

void main (void)
{
    ViStatus      errStatus;    /*return error code from visa call */
    ViSession     defaultRM;   /*default visa resource manager variable*/
    ViSession     vi;         /*current session handle */
    ViChar        replyBuf[256]; /*buffer holding answers from the
instrument*/
    ViChar        c;

```

```

/* Initialize visa resource manger */
    errStatus = viOpenDefaultRM (&defaultRM);
if(errStatus < VI_SUCCESS)
    { printf("Failed to open VISA Resource manager\n");
      exit(errStatus);
    }

/* Open session to GPIB device at address 20; the VI_NULL
parameters 3,4
are mandatory and not used for VISA 1.0*/
errStatus = viOpen (defaultRM, "GPIB::20::INSTR",
VI_NULL,VI_NULL,&vi);
if(errStatus < VI_SUCCESS)
    { printf("Failed to open instrument\n");
      exit(errStatus);
    }

/* set timeout to 20 sec; this should work for all commands except
for zeroing or READ commands with averaging times greater than the
timeout */
errStatus = viSetAttribute(vi,VI_ATTR_TMO_VALUE,20000);
checkError(vi,errStatus);

/* get the identification string of the instrument mainframe*/
errStatus = viQueryf(vi,"%s\n","%t","IDN?",replyBuf);
if(errStatus < VI_SUCCESS)
    { checkError(vi,errStatus); }
else printf("%s",replyBuf);

/* identify the installed modules */
errStatus = viQueryf(vi,"%s\n","%t","OPT?",replyBuf);
if(errStatus < VI_SUCCESS)
    { checkError(vi,errStatus); }
else printf("%s",replyBuf);

/* get information about the available options of a slot */
errStatus = viQueryf(vi,"%s","%t","SLOT1:OPT?\n",replyBuf);
if(errStatus < VI_SUCCESS)
    { checkError(vi,errStatus); }
else printf("%s",replyBuf);

/*loop, until a key is pressed */
while(!scanf("%c",&c));
/*close the session */
viClose(vi);
}

```

How to Set up a Fixed Laser Source

This example sets up a fixed laser source.

Install a Laser Source in Slot 2, before executing this example.

```
#include <stdio.h>
#include <stdlib.h>
#include <visa.h>

/* function prototypes for this examples */

/* function for simple error handling explained in example 1 */
void checkError(ViSession session, ViStatus err_status );

void main (void)
{
    ViStatus    errStatus;    /* returned error code from visa call */
    ViSession   defaultRM;   /* default visa resource manager
variable*/
    ViSession   vi;         /* current session handle */
    ViChar      c;          /* used in the keyboard wait loop */
    ViReal32    wavelength; /* wavelength of the laser source */

    /* initialize the visa library (see example 1) */
    errStatus = viOpenDefaultRM (&defaultRM);
    if(errStatus < VI_SUCCESS)
    {
        printf("Failed to open VISA Resource manager\n");
        exit(errStatus);
    }

    /* Open session to GPIB device at address 20;*/
    errStatus = viOpen (defaultRM, "GPIB::20::INSTR",
VI_NULL,VI_NULL,&vi);
    if(errStatus < VI_SUCCESS)
    {
        printf("Failed to open instrument\n");
        exit(errStatus);
    }

    /*set timeout to 20 sec; this should work for all commands except
zeroing */
```



```

errStatus = viSetAttribute(vi,VI_ATTR_TMO_VALUE,20000);
if (errStatus < VI_SUCCESS) checkError(vi,errStatus);

/* first get the wavelength of the laser source; to address the
second channel of a dual laser source use "CHAN2" instead of
"CHAN1"*/
errStatus =
viQueryf(vi,"%s","%f","SOURCE2:CHAN1:WAV?\n",&wavelength);
if (errStatus < VI_SUCCESS) checkError(vi,errStatus);
else
{ printf("Source Wavelength:%g\n",wavelength); }

/* to receive the maximum power the attenuation must be set to
zero */
errStatus = viPrintf(vi,"SOURCE2:CHAN1:ATT 0\n");
if (errStatus < VI_SUCCESS) checkError(vi,errStatus);

/* turn off amplitude modulation */
errStatus = viPrintf(vi,"SOURCE2:CHAN1:AM:STATE 0\n");
if (errStatus < VI_SUCCESS) checkError(vi,errStatus);

/* turn the laser on */
errStatus = viPrintf(vi,"SOURCE2:CHAN1:POW:STATE 1\n");
if (errStatus < VI_SUCCESS) checkError(vi,errStatus);

/* loop, until a key is pressed */

while(!scanf("%c",&c));

/* turn the laser off */
errStatus = viPrintf(vi,"SOURCE2:CHAN1:POW:STATE 0\n");
if (errStatus < VI_SUCCESS) checkError(vi,errStatus);

/* close the session */
viClose(vi);
}

void checkError(ViSession session, ViStatus err_status )
{
ViStatus error;
ViChar errMsg[256];
error = viQueryf(session,"SYST:ERR?\n","%t",errMsg);
if (error == VI_ERROR_TMO)
{
printf("System Error!\n") ;
exit(1);
}
else

```

```
{
    /* only errors should be displayed */
    if(errMsg[0] != '+')
        printf("error:%ld --> %s\n", err_status,errMsg) ;
}
```

How to Measure Power using FETCh and READ

The example shows the difference between a "FETCh" and a "READ" command.

Install a power meter in Slot 1, before executing this example.

```
#include <stdio.h>
#include <stdlib.h>
#include <string.h>
#include <visa.h>

/* function prototypes for this examples */

/* function for a simple error handling explained in example 1 */
void checkError(ViSession session, ViStatus err_status );

void main (void)
{
    ViStatus      errStatus;      /* returned error code from visa call */
    ViSession     defaultRM;      /* default visa resource manager
variable */
    ViSession     vi;             /* current session handle */
    ViChar        replyBuf[256]; /* buffer holding answers of the
instrument*/
    ViChar        compBuf[256]; /* buffer used for comparsion */
    ViChar        c;              /* used in the keyboard wait loop */
    ViReal64      averagingTime; /* averaging time */
    ViInt32       i;              /* loop counter */

    errStatus = viOpenDefaultRM (&defaultRM);
    if(errStatus < VI_SUCCESS)
    {
        printf("Failed to open VISA Resource manager\n");
        exit(errStatus);
    }

    errStatus = viOpen (defaultRM, "GPIB::20::INSTR",
VI_NULL,VI_NULL,&vi);
    if(errStatus < VI_SUCCESS)
    {
        printf("Failed to open instrument\n");
        exit(errStatus);
    }
}
```

```

    }
    /*set timeout to 20 sec; this should work for all commands
    except zeroing */
    errStatus = viSetAttribute(vi,VI_ATTR_TMO_VALUE,20000);
    if (errStatus < VI_SUCCESS) checkError(vi,errStatus);

    /* make sure that the reference is not used */
    errStatus = viPrintf(vi,"SENS1:CHAN1:POW:REF:STATE 0\n");
    if (errStatus < VI_SUCCESS) checkError(vi,errStatus);

    /* clear the error queue */
    errStatus = viPrintf(vi,"CLS\n");
    if (errStatus < VI_SUCCESS) checkError(vi,errStatus);

    /* turn auto range on */
    errStatus = viPrintf(vi,"SENS1:CHAN1:POW:RANGE:AUTO 1\n");
    if (errStatus < VI_SUCCESS) checkError(vi,errStatus);

    /* change the power unit to watt */
    errStatus = viPrintf(vi,"SENS1:CHAN1:POW:UNIT W\n");
    if (errStatus < VI_SUCCESS) checkError(vi,errStatus);

    /*set the averaging time for measuring to 0.5s*/
    averagingTime = 0.5;

    errStatus = viPrintf(vi,"SENS1:CHAN1:POW:ATIME
    %f\n",averagingTime);
    if (errStatus < VI_SUCCESS) checkError(vi,errStatus);

    /* turn continous measuring off */
    errStatus = viPrintf(vi,"INIT1:CHAN1:CONT 0\n");
    if (errStatus < VI_SUCCESS) checkError(vi,errStatus);

    /* trigger a measurement */
    errStatus = viPrintf(vi,"INIT1:CHAN1:IMM\n");
    if (errStatus < VI_SUCCESS) checkError(vi,errStatus);

    /* read 10 values and display the result; */
    for (i = 0; i < 10; i++)
    {
        /* Now because an averaged value is available, the value will be
        fetched */
        errStatus =
        viQueryf(vi,"%s","%s","FETCH1:CHAN1:POW?\n",replyBuf);
        if (errStatus < VI_SUCCESS) checkError(vi,errStatus);
        /* two consecutive values are compared; if they are equal it will be
        marked; because no evaluation is triggered, all values will be the same
        */
        if(i)

```

```

        { if(!strcmp(compBuf,replyBuf))
          { printf("Same:%s\n",replyBuf); }
          else printf("New:%s\n",replyBuf);
          }
        else printf("First:%s\n",replyBuf);
        strcpy(compBuf,replyBuf);
    }
    /* now the read command is used in the same manner to
    demonstrate the difference between fetch and read */

    /* read also 10 values, compare them and display the result; */
    for (i = 0; i < 10; i++)
    {
        /* In comparison to the "FETCH" command, the "READ"
        command implies triggering a measurement. Make sure the
        timeout set is greater than the adjusted averaging time, so that the
        READ command will not time out; */

        /* send the read command */
        errStatus = viQueryf(vi,"READ1:CHAN1:POW?\n","%t",replyBuf);
        checkError(vi,errStatus);

        if(i)
        {
            if(!strcmp(compBuf,replyBuf)) printf("Same:%s",replyBuf);
            else printf("New :%s",replyBuf);
        }
        else printf("\nFirst:%s",replyBuf);
        /*copy new value to compare buffer*/
        strcpy(compBuf,replyBuf);
    }
    /* loop, until a key is pressed */
    while(!scanf("%c",&c));

    checkError(vi,errStatus);
    /* close the session */
    viClose(vi);
}

void checkError(ViSession session, ViStatus err_status )
{ ViStatus error;
  ViChar errMsg[256];
  error = viQueryf(session,"SYST:ERR?\n","%t",errMsg);
  if (error == VI_ERROR_TMO)
  {
      printf("System Error!\n") ;
      exit(1);
  }
}

```

```
else
{
/* only errors should be displayed */
if(errMsg[0] != '+')
printf("error:%ld --> %s\n", err_status,errMsg) ;
}
}
```

How to Co-ordinate Two Modules

This example shows the interaction of two modules in the same frame.

Install a Power Sensor in Slot 1 and a Laser Source in Slot 2 and connect the Laser Source output to the Power Sensor input, before executing this example.

```

#include <stdio.h>
#include <stdlib.h>
#include <string.h>
#include <visa.h>

/* function prototypes for this examples */

/* function for a simple error handling explained in example 1 */
void checkError(ViSession session, ViStatus err_status );

void main (void)
{
    ViStatus    errStatus;    /* returned error code from visa call */
    ViSession   defaultRM;    /* default visa resource manager variable */
    ViSession   vi;          /* current session handle */
    ViChar      replyBuf[256]; /* buffer holding answers of the
instrument */
    ViChar      c;           /* used in the keyboard wait loop */
    ViInt32     i;           /* loop counter */
    ViInt32     cmdDone;     /* return value for OPC command */

    /* First get initialized the visa library (see example 1) */
    errStatus = viOpenDefaultRM (&defaultRM);
    if(errStatus < VI_SUCCESS)
    {
        printf("Failed to open VISA Resource manager\n");
        exit(errStatus);
    }

    /* Open session to GPIB device at address 20; */

```

```
errStatus = viOpen (defaultRM, "GPIB::20::INSTR",
VI_NULL,VI_NULL,&vi);
if(errStatus < VI_SUCCESS)
{
    printf("Failed to open instrument\n");
    exit(errStatus);
}

/* set timeout to 20 sec; this should work for all commands except
zeroing */
errStatus = viSetAttribute(vi,VI_ATTR_TMO_VALUE,20000);
if (errStatus < VI_SUCCESS) checkError(vi,errStatus);

/* clear error queue */
errStatus = viPrintf(vi,"CLS\n");
checkError(vi,errStatus);

/* read the wavelength from the laser source */
errStatus = viQueryf(vi,"SOURCE2:CHAN1:WAV?\n","%s",replyBuf);
checkError(vi,errStatus);

/* feed the source wavelength into the power meter making
sure to measure the maximum power of the source */
errStatus = viPrintf(vi,"SENS1:CHAN1:POW:WAV %s\n",replyBuf);
checkError(vi,errStatus);

/* turn auto range on */
errStatus = viPrintf(vi,"SENS1:CHAN1:POW:RANGE:AUTO 1\n");
checkError(vi,errStatus);

/* change the power unit of the power meter to dBm */
errStatus = viPrintf(vi,"SENS1:CHAN1:POW:UNIT 0\n");
checkError(vi,errStatus);

/*set the averaging time for measuring to 20 ms,
therefore no timeout needs to implemented */
errStatus = viPrintf(vi,"SENS1:CHAN1:POW:ATIME 0.02\n");
checkError(vi,errStatus);

/* set the attenuation to zero for maximum power */
errStatus = viPrintf(vi,"SOURCE2:CHAN1:POW:ATT 0.0\n");
checkError(vi,errStatus);

/* set the reference mode to the internal one,
which is now the last displayed value */
```



```

errStatus = viPrintf(vi,"SENS1:CHAN1:POW:REF:STATE:RATIO
TOREF,0\n");
checkError(vi,errStatus);

/* set reference measurement state to absolute units */
errStatus = viPrintf(vi,"SENS1:CHAN1:POW:REF:STAT 1\n");
checkError(vi,errStatus);

/* turn laser on */
errStatus = viPrintf(vi,"SOURCE2:CHAN1:POW:STATE 1\n");
checkError(vi,errStatus);
/*ask for command completion */
do
{
errStatus = viQueryf(vi,"*OPC?\n", "%d",&cmdDone);
checkError(vi,errStatus);
} while (!cmdDone);

/* set the power meter reference to the displayed value (display to
reference) */
errStatus = viPrintf(vi,"SENS1:CHAN1:POW:REF:DISP\n");
checkError(vi,errStatus);

/*
read 30 values and display the result; after ten measurements
the source output will be halved by making use of the
attenuation;
after an other ten measurements the source output will be
halved
a second time;
because of the display to reference command and using the
reference, the value printed should be more or less equal to the
adjusted source attenuation */

for (i = 1; i <= 30; i++)
{
errStatus = viQueryf(vi,"READ1:CHAN1:POW?\n", "%s",replyBuf);
checkError(vi,errStatus);
if(errStatus ==VI_SUCCESS)printf("power
#%02d:%s\n",i,replyBuf);
if(i == 10)
{
/* reduce the output power for 3.0 dB */
errStatus = viPrintf(vi,"SOURCE2:CHAN1:POW:ATT 3.0\n");
checkError(vi,errStatus);
}
if(i == 20)

```

```

        {
            /* reduce the output power for 6.0 dB */
            errStatus = viPrintf(vi,"SOURCE2:CHAN1:POW:ATT 6.0\n");
            checkError(vi,errStatus);
        }

    }

    /* loop, until a key is pressed */
    while(!scanf("%c",&c));

    /* turn the laser off */
    errStatus = viPrintf(vi,"SOURCE2:CHAN1:POW:STATE 0\n");
    if (errStatus < VI_SUCCESS) checkError(vi,errStatus);

    /*close the session */
    viClose(vi);

}

void checkError(ViSession session, ViStatus err_status )
{
    ViStatus error;
    ViChar errMsg[256];
    error = viQueryf(session,"SYST:ERR?\n","%t",errMsg);
    if (error == VI_ERROR_TMO)
    {
        printf("System Error!\n") ;
        exit(1);
    }
    else
    {
        /* only errors should be displayed */
        if(errMsg[0] != '+')
            printf("error:%ld --> %s\n", err_status,errMsg) ;
    }
}

```

How Power Varies with Wavelength

This example shows how the measured power depends on wavelength.

Install a Power Sensor in Slot 1 and a Tunable Laser Source in Slot 2 and connect the Tunable Laser Source output to the Power Sensor input, before executing this example.

```

#include <stdio.h>
#include <stdlib.h>
#include <string.h>
#include <visa.h>

/* function prototypes for this examples*/

/* function for a simple error handling explained in example 1 */
void checkError(ViSession session, ViStatus err_status );

void main (void)
{
    ViStatus    errStatus;    /* returned error code from visa call */
    ViSession   defaultRM;    /* default visa resource manager
variable*/
    ViSession   vi;          /* current session handle */
    ViChar      replyBuf[256]; /*buffer holding answers of the
instrument */
    ViChar      c;           /* used in the keyboard wait loop */
    ViReal64    wavelength;  /* used to hold the wavelength of the
tunable laser source */
    ViReal64    wavelength_max; /*used to hold the maximum
wavelength of the tunable laser source*/
    ViInt32     i;           /* loop counter */
    ViInt32     cmdDone;     /* return value for OPC command */

    errStatus = viOpenDefaultRM (&defaultRM);
    if(errStatus < VI_SUCCESS)
    {
        printf("Failed to open VISA Resource manager\n");
        exit(errStatus);
    }
}

```

```
errStatus = viOpen (defaultRM, "GPIB::20::INSTR",
VI_NULL,VI_NULL,&vi);
if(errStatus < VI_SUCCESS)
{
    printf("Failed to open instrument\n");
    exit(errStatus);
}

/*set timeout to 20 sec; this should work for all commands
except zeroing */
errStatus = viSetAttribute(vi,VI_ATTR_TMO_VALUE,20000);
checkError(vi,errStatus);

errStatus = viPrintf(vi,"*CLS\n");
checkError(vi,errStatus);

/* read the minimum wavelength from the tunable laser source*/
errStatus = viQueryf(vi,"SOURCE2:WAV? MIN\n","%s",replyBuf);
checkError(vi,errStatus);

/* save this wavelength */
wavelength = atof(replyBuf);

/* set the minimum wavelength as initial wavelength in the tunable
laser source */
errStatus = viPrintf(vi,"SOURCE2:WAV %s\n",replyBuf);
checkError(vi,errStatus);

/* set the power meter to same wavelength like the tunable laser
source */
errStatus = viPrintf(vi,"SENS1:CHAN1:POW:WAV %s\n",replyBuf);
checkError(vi,errStatus);

/* read the maximum wavelength from the tunable laser source */
errStatus = viQueryf(vi,"SOURCE2:WAV? MAX\n","%s",replyBuf);
checkError(vi,errStatus);

/*save this wavelength */
wavelength_max = atof(replyBuf);

/* change the power unit of the power meter to dbm */
errStatus = viPrintf(vi,"SENS1:CHAN1:POW:UNIT DBM\n");
checkError(vi,errStatus);
```

```

/* read the default power from the tunable laser source */
errStatus = viQueryf(vi,"SOURCE2:POW? DEF\n","%s",replyBuf);
checkError(vi,errStatus);

/* set the default power */
errStatus = viPrintf(vi,"SOURCE2:POW %s\n",replyBuf);
checkError(vi,errStatus);

/* turn auto range on*/
errStatus = viPrintf(vi,"SENS1:CHAN1:POW:RANGE:AUTO 1\n");
checkError(vi,errStatus);

/*set the averaging time for measuring to 20ms*/
errStatus = viPrintf(vi,"SENS1:CHAN1:POW:ATIME 0.02\n");
checkError(vi,errStatus);

/* turn laser on */
errStatus = viPrintf(vi,"SOURCE2:POW:STATE 1\n");
checkError(vi,errStatus);

/* increase the wavelength of the tunable laser source 10 nm
   until the maximum is reached.
   read the results from the power meter and display it */

for(i=1;1;i++)
{
    /*query the power */
    errStatus = viQueryf(vi,"READ1:CHAN1:POW?\n","%s",replyBuf);
    checkError(vi,errStatus);

    /* display the power read from power meter and wavelength */
    printf("#%02d power:%s
wavelength:%g\n",i,replyBuf,wavelength);

    /* increase the wavelength */
    wavelength += 10.0e-9;
    if(wavelength > wavelength_max) break;
    /*set the new wavelength*/
    errStatus = viPrintf(vi,"SOURCE2:WAV %g\n",wavelength);

    /*
    poll the instrument for completion of this command
    because adjusting a new wavelength takes some time

```

```

    */
    do
    {
        errStatus = viQueryf(vi,"*OPC?\n", "%d",&cmdDone);
        checkError(vi,errStatus);
    } while (!cmdDone);

}

/* loop, until a key is pressed */
while(!scanf("%c",&c));

/* turn laser off */
errStatus = viPrintf(vi,"SOURCE2:CHAN1:POW:STATE 0\n");
checkError(vi,errStatus);

/* close the session */
viClose(vi);

}

void checkError(ViSession session, ViStatus err_status )
{
    ViStatus error;
    ViChar errMsg[256];
    error = viQueryf(session,"SYST:ERR?\n", "%t",errMsg);
    if (error == VI_ERROR_TMO) printf("System Error!\n") ;
    else
    {
        /* only errors should be displayed */
        if(errMsg[0] != '+')
            printf("error:%ld --> %s\n", err_status,errMsg) ;
    }
}

```

How to Log Results

This example demonstrates how to use logging functions.

Install a Power Sensor in Slot 1, before executing this example.

```

#include <stdio.h>
#include <stdlib.h>
#include <string.h>
#include <visa.h>

#define MAX_LOG_VALUES 4000 /* max number of values the
instrument is able to log */
#define HEADER_SIZE 7 /* includes 6 bytes header and 1 CR */

/* function prototypes for this examples*/

/* function for a simple error handling explained in example 1 */
void checkError(ViStatus session, ViStatus err_status );

/* initialize the visa interface */
ViStatus InitVisa ( ViSession *iHandle);

/*globals*/
static unsigned char logBuffer[MAX_LOG_VALUES * sizeof(ViReal64) +
HEADER_SIZE];
/*array for the float results */
static ViReal32 logResults[MAX_LOG_VALUES];

void main (void)
{
    ViStatus errStatus; /* returned error code from visa call */
    ViSession vi; /* current session handle */
    ViChar replyBuf[256]; /* buffer holding answers from the
instrument */
    ViChar c; /* used in the keyboard wait loop */
    ViInt32 slot; /* slot number where the power meter is
plugged */
    ViInt32 chan; /* channel to be logged */
    ViInt32 i; /* loop counter */
    ViInt32 noOfValues; /* number of values to be logged*/
    ViReal64 averagingTime; /* aveaging time used in a logging cycle
*/
    ViPChar replySubStr; /* pointer to a substring of the
instruments reply */

```

```

    ViInt32    noOfDigits;    /*number of digits, specifying the amount
data
to be read */
    ViUInt32    retCnt;        /* returns the number of bytes read
calling viRead */

    errStatus = InitVisa(&vi);

    if(errStatus < VI_SUCCESS)
    {
        exit(errStatus);
    }

    /* clear instrument error queue */
    errStatus = viPrintf(vi,"CLS\n");
    checkError(vi,errStatus);

    /* turn auto range on */
    errStatus = viPrintf(vi,"SENS1:CHAN1:POW:RANGE:AUTO 1\n");
    checkError(vi,errStatus);

    /* send the command sequence for continuous logging */
    slot = 1;
    chan = 1;
    noOfValues = 100;    /* log 100 values */
    averagingTime = 0.02; /* set averaging time to 20ms */
    viPrintf(vi,"SENS%1d:CHAN%1d:FUNC:PAR:LOGG %d,%f\n",
        slot,
        chan,
        noOfValues,
        averagingTime);
        checkError(vi,errStatus);

    /* start logging */
    viPrintf(vi,"SENS%1d:CHAN%1d:FUNC:STAT
LOGG,START\n",slot,chan);
        checkError(vi,errStatus);

    /* to display the results, logging should be completed */
    /* the instrument has to be polled about the progress of the logging
*/
    do
    {
        errStatus =
viQueryf(vi,"SENS%1d:CHAN%1d:FUNC:STATE?\n","%t",slot,chan,replyBuf
);

        /* if an error occurs break the loop */
        if (errStatus < VI_SUCCESS)
        {
            checkError(vi,errStatus);

```



```

        break;
    }

    /* find the substring "COMPLETE" in the reply of the instrument
    */

    replySubStr = replyBuf;
    while(*replySubStr)
    {
        if(!strncmp(replySubStr,"COMPLETE",strlen("COMPLETE")))
            break;
        replySubStr ++;
    }
    }while (*replySubStr); /*substring "COMPLETE" not found */
    /*continue polling */

    /* The instrument returns the logging result in the following format:
    #xyyyffff...; the first digits after the hash denotes the number of ascii
    digits following (y) ; y specifies the number of binary data following;
    "ffff" represent the 32Bit floats as log result. */
    /* get the result */
    errStatus =
    viPrintf(vi,"SENS%1d:CHAN%1d:FUNC:RES?\n",slot,chan);
    /* only query an error, if there is one, else the query will be
    interrupted ! */
    if(errStatus < VI_SUCCESS)checkError(vi,errStatus);

    /* read the binary data */
    errStatus = viRead(vi, logBuffer, MAX_LOG_VALUES *
    sizeof(ViReal32) + HEADER_SIZE, &retCnt);
    checkError(vi,errStatus);

    if(logBuffer[0] != '#')
    {
        printf("invalid format returned from logging\n");
        exit(1);
    }
    else
    {
        noOfDigits = logBuffer[1] - '0';
        memcpy( logResults, &logBuffer[2 + noOfDigits ],
        MAX_LOG_VALUES * sizeof(ViReal32));
    }

    /* stop logging */
    viPrintf(vi,"SENS%1d:CHAN%1d:FUNC:STAT
    LOGG,STOP\n",slot,chan);
    checkError(vi,errStatus);

```

```

    /* display the values using %g, a float format specifier, you may
    also use %e or %f */
    for ( i = 0; i < noOfValues; i++)
        printf("\t\t%g\n",logResults[i]);

    /* loop, until a key is pressed */
    while(!scanf("%c",&c));

    /* close the session */
    viClose(vi);

}

void checkError(ViStatus session, ViStatus err_status )
{
    ViStatus error;
    ViChar errMsg[256];
    error = viQueryf(session,"SYST:ERR?\n","%t",errMsg);
    if (error == VI_ERROR_TMO)
    {
        printf("System Error!\n") ;
        exit(1);
    }
    else
    {
        /* only errors should be displayed */
        if(errMsg[0] != '+')
        {
            printf("error:%ld --> %s\n", err_status,errMsg) ;
            if
                ((!strncmp(errMsg,
                "-303,\"Module slot empty or slot / channel invalid\"",
                strlen("-303,\"Module slot empty or slot / channel invalid\"")))
                ||
                (!strncmp(errMsg,
                "-301,\"Module doesn't support this command
(StatCmdUnknown)\\"",
                strlen(
                "-301,\"Module doesn't support this command
(StatCmdUnknown)\\"))))
            {
                printf("No power meter in slot 1 so exiting\n\n");
                exit(1);
            }
        }
    }
}

ViStatus InitVisa ( ViSession *iHandle)

```

```
{
    ViStatus    errStatus;    /* returned error code from visa call */
    ViSession   defaultRM;    /* default visa resource manager variable
*/

    /* First get initialized the visa library (see example 1) */
    errStatus = viOpenDefaultRM (&defaultRM);
    if (errStatus < VI_SUCCESS)
        printf("Failed to open VISA Resource manager\n");

    /* Open session to GPIB device at address 20; */
    errStatus = viOpen (defaultRM, "GPIB::20::INSTR",
                       VI_NULL,VI_NULL,iHandle);
    if (errStatus < VI_SUCCESS)
        printf("Failed to open instrument\n");

    return errStatus;
}
```

7

The Agilent 816x *VXIplug&play* Instrument Driver

This chapter gives you extra information about installing and getting started with the Agilent 816x *VXIplug&play* instrument driver.

There are details about opening and closing an instrument session, data types and constants used, error handling, and the programming environments supported.

Installing the Agilent 816x Instrument Driver	214
Using Visual Programming Environments	218
Getting Started with Agilent VEE	218
Getting Started with LabView	221
Getting Started with LabWindows	224
Features of the Agilent 816x Instrument Driver	225
Directory Structure	226
Opening an Instrument Session	227
Closing an Instrument Session	228
VISA Data Types and Selected Constant Definitions	229
Error Handling	230
Introduction to Programming	232
Example Programs	232
VISA-Specific Information	232
Development Environments	232
Online Information	234
Lambda Scan Applications	235
How to Perform a Lambda Scan Application	237
How to Perform a Multi-Frame Lambda Scan Application	239

Installing the Agilent 816x Instrument Driver

The Agilent 816x VXi*plug&play* Instrument Driver comes as a self-extracting archive with an installation wizard. The installation wizard extracts all the files to preset destinations, asking you appropriate questions as it does so.

You install the driver by running the executable hp816x.exe.

1 Run hp816x.exe,

The welcome screen for the InstallShield Wizard used to install the Agilent 816x VXi*plug&play* Instrument Driver is displayed.

2 Press Next> to continue.

Specify the folder to which files will be saved.

3 Press Next> to continue.

Files are copied and extracted.

If necessary, a dialog requests your permission to overwrite existing files.

The version number of the instrument driver is displayed.

You may now elect to skip installation at this PC. Copy the extracted disk images to floppy, and use them to install the instrument driver at another PC.

4 Press OK> to continue.

If you are not an administrator, you see a VXi*plug&play* window, and a message telling you that if you proceed with the installation, some information will NOT be visible to all users. This means that any program menu options will only be available to the user that performed the installation. If you are the administrator all program menu options will be visible for all users.

If you see the message in Figure 9 , press Yes to install the driver or press No and contact your administrator.

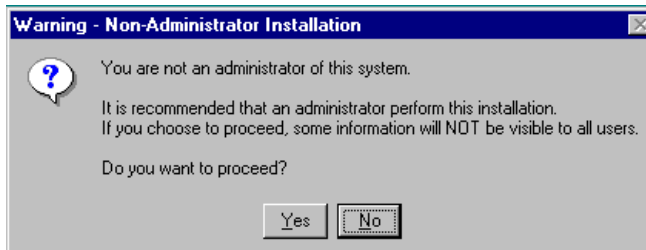

Figure 9 Non-Administrator Installation Pop-Up Box

NOTE

If Agilent 816x VXI*plug&play* Instrument Driver is already installed on your system, you see a message asking you if you want to uninstall the old version.

Press Yes, if required, then wait until you see a message telling you that the uninstall has been successful. You may be asked for permission to remove shared files.

Then press OK to continue.

- 5 You see a message, as shown in Figure 10 , advising you to close the programs that you have running.

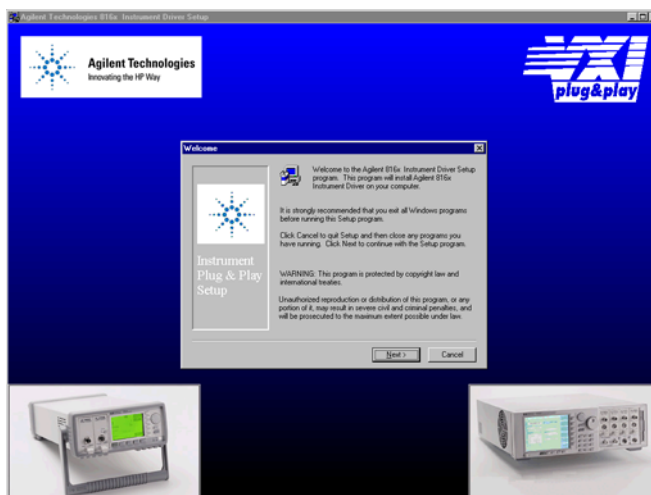

Figure 10 Welcome Screen

- 6 Close these programs and press Next> to continue. Then, you see a message informing you if VISA is installed on your PC.

NOTE

If you do not have VISA installed, press **Cancel** to temporarily exit this installation procedure; install VISA on your PC, then run hp816x.exe again.

If you have VISA installed, press Next> to continue. You see a window that requests you to choose your Setup.

- 7 You can choose a Typical, Compact, or Custom Setup. Choose a setup option and press Next> to continue.

NOTE

If you choose the Custom Setup, you may choose the options you want to install from the screen in Figure 11 . These options are:

- VxiPnP Driver, you may choose to install the Agilent 816x VXIplug&play instrument driver.
- Examples, you may choose to install Visual Basic, Visual C, LabView, Agilent VEE and VISA programming examples.
- Help Files, you may choose to install the help file.

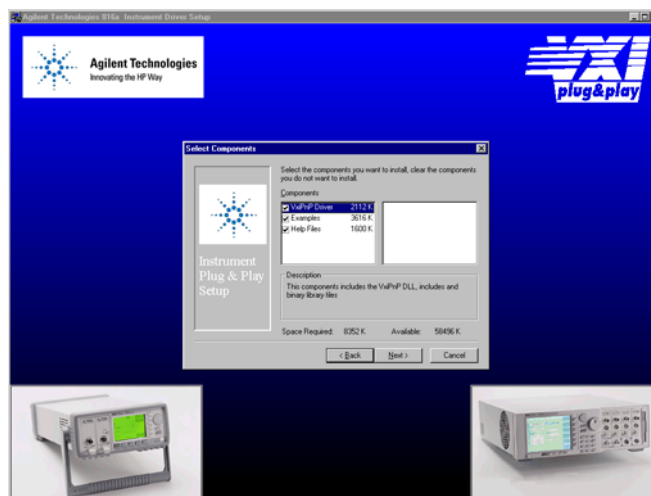

Figure 11 Customizing Your Setup

Select the components you want to install.

8 Press **N**ext> to continue.

Specify the program folder required; the default choice is VXIPNP.

9 Press **N**ext> to continue.

Review the settings that you have specified.

If you want to review or change any settings press **B**ack>

10 Press **N**ext> to continue.

The instrument driver is installed.

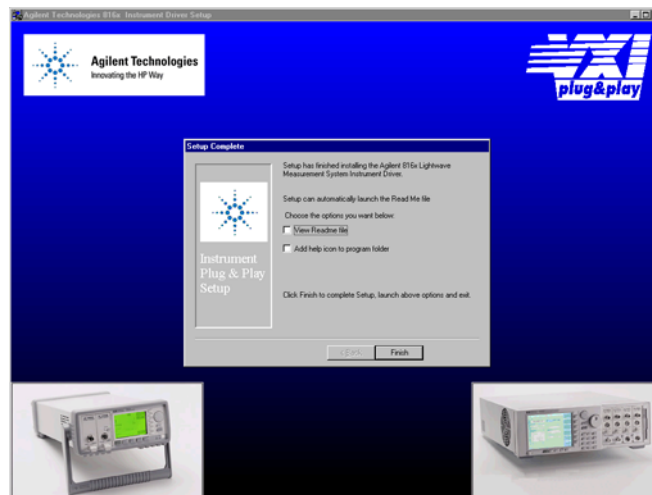

Figure 12 Program Folder Item Options

You may elect to:

- Automatically launch the Readme file, which provides the instrument driver's version history
- Include a help icon in your program folder, which launches on-line documentation for the instrument driver

11 Press **F**inish to complete installation

If you elected to automatically launch the Readme file, it is displayed.

A webpage explaining how to get started with the Agilent 816x

VXIplug&play Instrument Driver using Agilent VEE or LabView appears.

Using Visual Programming Environments

Getting Started with Agilent VEE

Agilent Technologies Visual Engineering Environment (Agilent VEE) is a visual programming language optimized for instrument control applications. To develop programs in Agilent VEE, you connect graphical 'objects' instead of writing lines of code. These programs resemble easy-to-understand block diagrams with lines.

Agilent VEE allows you to leverage your investment in textual languages by integrating with languages such as C, C++, Visual Basic, FORTRAN, Pascal, and Agilent BASIC.

Agilent VEE controls GPIB, VXI, Serial, PC Plug-in, and LAN instruments directly over the interfaces or by using instrument drivers.

Agilent VEE supports *VXIplug&play* drivers in the WIN, WIN95, WINNT, and Agilent-UX frameworks. In addition, versions 3.2 and above of Agilent VEE support the graphical Function Panel interface, providing a function tree of the hierarchy of the driver.

NOTE

This appendix assumes that you are using Windows 95. If you are using Windows NT, please replace every reference to win95 with winnt. Windows 95 and Windows NT are registered trademarks of Microsoft corporation.

Agilent VEE automatically calls the *initialize* and *close* functions to perform automatic error checking.

GPIB Interfacing in Agilent VEE

Agilent VEE supports interfacing with an instrument from a GPIB card. Before you can do this, you must do the following:

- 1 Select Instrument Manager from the I/O menu.

- 2 Double-click on the Add button to bring up the Device Configuration screen, see Figure 13 .

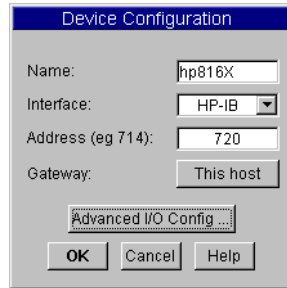

Figure 13 Device Configuration

- 3 Enter the following information:

- **Name:** enter hp816X.
- **Interface:** GPIB
- **Address:** Enter the GPIB address of your GPIB interface board (the default is 7). Append the GPIB address of your instrument (the default is 20).

NOTE

To find out or change the instrument's GPIB address, press the *Config* hardkey on the instrument's front panel and choose GPIB address. The instrument's GPIB address appears, you may edit it if you wish.

- **Gateway:** This host.

- 4 Press Advanced I/O Config ..., the Advanced Device Configuration box pops up. Select the Plug&play Driver tab, the box in Figure 14 appears.

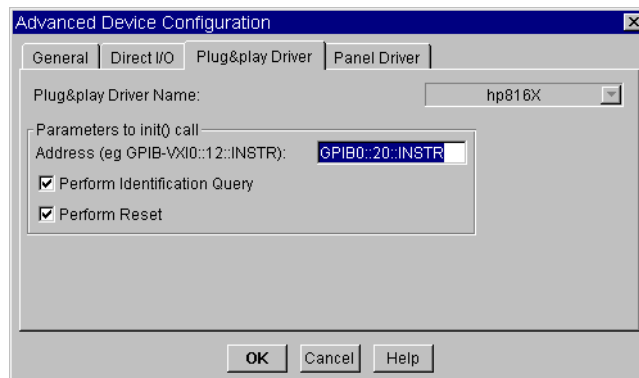

Figure 14 Advanced Device Configuration - Plug&play Driver

- 5 Select hp816X from the Plug&play Driver Name drop-down list.

NOTE

If you do not see this driver in the list, the driver has not installed properly.

If you do not see this driver in the list, the driver has not installed properly.

- 6 Enter the Parameters to the init() call by entering GPIB::xx::INSTR where xx is your instrument's GPIB address.

NOTE

20 is the default GPIB address for your instrument.

- 7 Select whether to Perform Reset or to Perform Identification Query whenever Agilent VEE opens the instrument for interaction.
- 8 Confirm the selections pressing the OK button.
- 9 Return to the Instrument Manager screen and press the Save Config to save the configuration.

Getting Started with LabView

The 32-bit Agilent 816x driver can be used with LabView 5.0 and above. LabView 5.0 is a 32-bit version of LabView which runs on Windows 95 and Windows NT.

After installing the Agilent 816x instrument driver, the driver must be converted for use with LabView.

- 1 To convert the driver follow these steps:
 - a If you are updating from a previously installed driver, perform the following three steps:
 - b Locate the LabView program folder. By default, this is <drive>:\Program Files\National Instruments\LabView.
 - c This folder contains a subfolder named instr.lib.
- 2 Run LabView.
- 3 On the first window that appears, click on the Solution Wizards button.
- 4 The LabView Solution Wizard window appears, click on the Launch Wizard... button.
- 5 The Welcome to Instrument Wizard! window appears, click on the Next > button.
- 6 The Search for Instruments... window appears, click on the Next > button. Check that the options are the same as displayed in the figure below:



Figure 15 Search for GPIB Instruments

- 7 Click on the Next > button.
- 8 The Identify Found Instruments... window appears, click on the Next > button.
- 9 The Update VXI Plug and Play Drivers window appears, select HP816X, and click on the Convert button.
- 10 The *Manage Instrument Drivers* window appears, click on the Finish button.
- 11 The first window appears again, click on the New VI button.
- 12 Select File and then select Convert CVI FP file.
- 13 The Select a CVI Function Panel file window appears, locate the hp816x.fp file, which is normally installed into the path <drive>:\VXI\PNP\winXX\hp816x, where XX stands for NT, or 95.
- 14 Press Open.
- 15 The CVI Function Panel Converter window appears.
- 16 Click on Browse... and browse to the following Destination Directory:
 \LabView\instr.lib\hp816x\hp816x.lib
- 17 Press Save.
- 18 Press Options..., the FP Conversion Options window appears. Check that the options are the same as displayed in the figure below:.

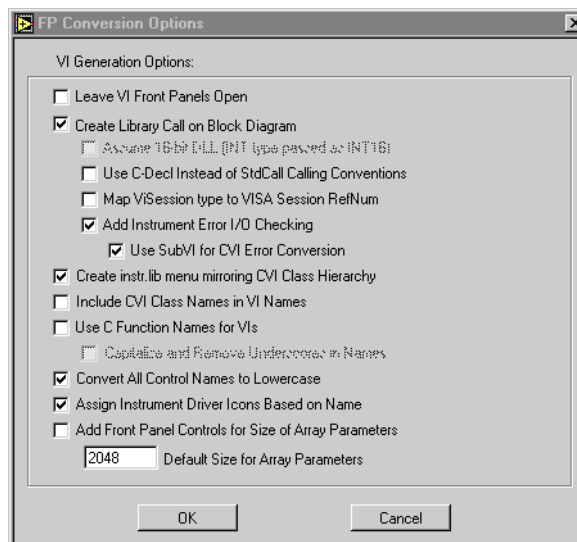

Figure 16 FP Conversion Options Box

NOTE

You must check the Add Front Panel Controls for Size of Array Parameters box. There will be a front panel control created for each VI that requires you to assign the array size.

19 Press OK. The CVI Function Panel Converter window appears.

20 Press OK.

21 The Select a library window appears. Browse to <drive>:\vxiinp\winXX\Bin, where XX stands for NT, or 95, select hp816x_32.dll and click on Open.

22 The CVI Conversion Status window is displayed until the conversion is completed.

NOTE

You must use the 32-bit version of the Agilent 816x VXIplug&play Instrument Driver with LabView 5.0.

NOTE

LabView is a trademark of National Instruments Corporation.

Getting Started with LabWindows

The 32-bit Agilent 816x *VXIplug&play* Instrument Driver can be used with LabWindows 4.0 and above. LabWindows 4.0 is a 32-bit version of LabWindows which runs on Windows 95 and Windows NT.

To access the functions of the Agilent 816x *VXIplug&play* Instrument Driver from within LabWindows, select INSTRUMENT from the main menu, and then select the LOAD... submenu item.

In the file selection dialog box which appears, select hp816x.fp and click on the OK button. LabWindows loads the function panel and instrument driver.

The driver now appears as a selection on the Instrument menu, and can be treated like any LabWindows driver.

NOTE

LabWindows is a trademark of National Instruments Corporation.

Features of the Agilent 816x Instrument Driver

The Agilent 816x VXI*plug&play* instrument driver conforms to all aspects of the VXI*plug&play* driver standard which apply to conventional rack and stack instruments.

The following features are available:

- The Agilent 816x VXI*plug&play* Instrument Driver conforms with the VXI*plug&play* standard.
- There is one exception as the Agilent 816x driver does not have a soft front panel or a knowledge-based file.
- The Agilent 816x VXI*plug&play* Instrument Driver is built on top of VISA, and uses the services provided.
- VISA supports GPIB and VXI protocols. The driver can be used with any GPIB card for which the manufacturer has provided a VISA DLL.
- The Agilent 816x VXI*plug&play* Instrument Driver includes a Function Panel (.fp) file.
- The .fp file allows the driver to be used with visual programming environments such as Agilent VEE, LabWindows, and LabView.
- The Agilent 816x VXI*plug&play* Instrument Driver includes a comprehensive on-line help file which complements the instrument manual.
- The help file contains application programming examples, a cross-reference between instrument commands and driver functions, and detailed documentation of each function with examples.
- The Agilent 816x VXI*plug&play* Instrument Driver includes a Visual Basic (.BAS) file which contains the function calls in Visual Basic syntax, and allows the driver functions to be called from Visual Basic.

You should only use Visual Basic with this driver if you are familiar with C/C++ function declarations. You must take particular care when working with C/C++ pointers.

Directory Structure

The setup program which installs the Agilent 816x instrument driver creates the VXIPNP directory if it does not already exist. The structures for the Windows NT and Windows 95 vxipnp subdirectory tree are shown in Figure 17 .

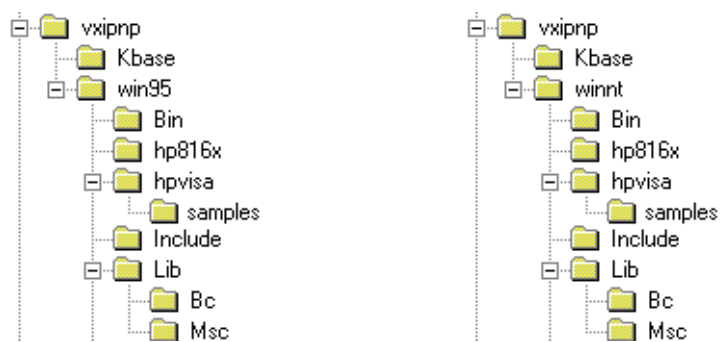

Figure 17 Windows 95 and Windows NT VXIPNP Directory Structure

In the directory example, hp816x is a directory containing the instrument driver. There would be a directory for each instrument driver.

Opening an Instrument Session

To control an instrument from a program, you must open a communication path between the computer/controller and the instrument. This path is known as an instrument session, and is opened with the function

```
ViStatus hp816x_init( ViRsrc InstrDesc, ViBoolean id_query, ViBoolean reset,
ViPSession instrumentHandle );
```

Instruments are assigned a handle when the instrument session is opened. The handle, which is a pointer to the instrument, is the first parameter passed in all subsequent calls to driver functions.

The parameters of the function `hp816x_init` include:

- **ViRsrc InstrDesc:** the address of the instrument
- **ViBoolean id_query:** a Boolean flag which indicates if in-system verification should be performed.
Passing `VI_TRUE` (1) will perform an in-system verification; passing `VI_FALSE` (0) will not.
If you set `id_query` to false, you can use the generic functions of the instrument driver with other instruments.
- **ViBoolean reset:** a Boolean flag which indicates if the instrument should be reset when it is opened.
Passing `VI_TRUE` (1) will perform a reset when the session is opened; passing `VI_FALSE` (0) will not perform a reset,
- **ViPSession instrumentHandle:** a pointer to an instrument session.
`InstrumentHandle` is the handle which addresses the instrument, and is the first parameter passed in all driver functions.

Successful completion of this function returns `VI_SUCCESS`

Closing an Instrument Session

Sessions (instrumentHandle) opened with the hp816x_init() function are closed with the function:

```
hp816x_close( ViSession instrumentHandle);
```

When no further communication with an instrument is required, the session must be explicitly closed (hp816x_close() function).

VISA does not remove sessions unless they are explicitly closed. Closing the instrument session frees all data structures and system resources allocated to that session.

VISA Data Types and Selected Constant Definitions

The driver functions use VISA data types. VISA data types are identified by the Vi prefix in the data type name (for example, ViInt16, ViUInt16, ViChar).

The file visatype.h contains a complete listing of the VISA data types, function call casts and some of the common constants.

NOTE

You can find a partial list of the type definitions and constant definitions for the visatype.h in the Agilent 816x VXIplug&play Instrument Driver Online Help.

Error Handling

Events and errors within a instrument control program can be detected by polling (querying) the instrument. Polling is used in application development environments (ADEs) that do not support asynchronous activities where callbacks can be used.

Programs can set up and use polling as shown below.

- 1 Declare a variable to contain the function completion code.

```
ViStatus errStatus;
```

Every driver function returns the completion code ViStatus.

If the function executes with no I/O errors, driver errors, or instrument errors, ViStatus is 0 (VI_SUCCESS).

If an error occurs, ViStatus is a negative error code.

Warnings are positive error codes, and indicate the operation succeeded but special conditions exist.

- 2 Enable automatic instrument error checking following each function call.

```
hp816x_errorQueryDetect  
(instrumentHandle, VI_TRUE);
```

When enabled, the driver queries the instrument for an error condition before returning from the function.

If an error occurred, errStatus (Step 1) will contain a code indicating that an error was detected (hp816x_INSTR_ERROR_DETECTED).

- 3 Check for an error (or event) after each function.

```
errStatus = hp816x_cmd(instrumentHandle, "SENS1:POW:RANG");  
check(instrumentHandle, errStatus);
```

After the function executes, errStatus contains the completion code.

The completion code and instrument ID are passed to an error checking routine. In the above statement, the routine is called 'check'.

- 4 Create a routine to respond to the error or event. This example queries whether an error has occurred, checks if the error is an instrument error and then checks if the error is a driver error.

```

void check (ViSession instrumentHandle, ViStatus errStatus)
{
    /* variables for error code and message */
    ViInt32 inst_err;
    ViChar err_message[256];

    /* VI_SUCCESS is 0 and is defined in VISATYPE.h */
    if(VI_SUCCESS > errStatus)
    {
        /* hp816x_INSTR_ERROR_DETECTED defined in hp816x.h */
        if(hp816x_INSTR_ERROR_DETECTED == errStatus)

            {
                /* query the instrument for the error */
                hp816x_error_query(instrumentHandle, &inst_err, err_message);

                /* display the error */
                printf("Instrument Error : %ld, %s\n", inst_err, err_message);
            }
        else /* driver error */
        {
            /* get the driver error message */
            hp816x_error_message(instrumentHandle, errStatus,
err_message);

            /* display the error */
            printf("Driver Error : %ld, %s\n", errStatus, err_message);

        }
        /* optionally reset the instrument, close the instrument handle
*/
        hp816x_reset(instrumentHandle);
        hp816x_close(instrumentHandle);
        exit(1);
    }
    return;
}

```

Introduction to Programming

Example Programs

See the Online Help and “*VISA Programming Examples*” on page 189.

VISA-Specific Information

The following information is useful if you are using the driver with a version of VISA.

Instrument Addresses

When you are using Agilent VXi*plug&play* instrument drivers, you should enter the instrument addresses using only upper case letters. This is to ensure maximum portability.

For example, use GPIB0::22 rather than gpib0::22.

Callbacks

Callbacks are not supported by this driver.

Development Environments

These sections contains suggestions as to how you can use hp816x_32.dll within various application development environments.

Microsoft Visual C++ 4.0 (or higher) and Borland C++ 4.5 (or higher)

Please refer to your Microsoft Visual C++ or Borland C++ manuals for information on linking and calling DLLs.

Microsoft Visual Basic 4.0 (or higher)

Please refer to your Microsoft Visual Basic manual for information on calling DLLs.

The BASIC include file is hp816x.bas. You can find this file in the directory ~\vxipnp\win95\include, where ~ is the directory in the VXIPNP variable.

By default, ~ is equivalent to C:\. This means that the file is in C:\vxipnp\win95\include.

You may also need to include the file visa.bas. visa.bas is provided with your VISA DLL.

Agilent VEE 5.01 (or higher)

Your copy of Agilent VEE for Windows contains a document titled *Using VXIplug&play drivers with Agilent VEE for Windows*. This document contains the detailed information you need for Agilent VEE applications.

LabWindows CVI/ (R) 4.0 (or higher)

The Agilent 816x VXIplug&play Instrument Driver is supplied as a Dynamic Link Library (.DLL) file.

There are several advantages to using the .DLL form of the driver, including those listed below:

- transportability across different computer platforms,
- a higher level of support for the compiled driver from Agilent Technologies,
- a faster load time for your project.

LabWindows/CVI (R) will attempt by default to load the source version of the instrument driver. To load the DLL, you must include the file hp816x.fp in your project. hp816x.fp can be found in the directory vxipnp\win95\hp816x.

Do not include hp816x.C in your project.

You must provide an include file for hp816x.H. You do this by ensuring that the directory ~\vxipnp\win95\include is added to the include paths (CVI Project Option menu).

~ is the directory in the VXIPNP variable. By default, ~ is equivalent to C:\. This means that the file is in C:\vxipnp\win95\include.

Online Information

The latest copy of this driver can be downloaded via:

<http://www.agilent.com/comms/comp-test>

If you do not have web access, use the version of hp816x.exe on your OCT Support CD, or contact your Agilent Technologies supplier.

Lambda Scan Applications

These functions combine multiple SCPI commands into a single, functional operation. They are designed to allow quick and easy access to common instrument command sequences.

These application functions allow you to perform one of the following applications:

- A Lambda Scan - a Lambda Logging operation where an Agilent 8164A/B Lightwave Measurement System with a back-loadable Tunable Laser module and up to four Power Meters installed, performs a wavelength sweep where the Tunable Laser module and Power Meters are coordinated with each other.
- A Multi Frame Lambda Scan - a Lambda Logging operation where an Agilent 8164A/B Lightwave Measurement System with a back-loadable Tunable Laser module performs a wavelength sweep and the Tunable Laser module is coordinated with Power Meters that are installed in the mainframe and in other mainframes. These mainframes must be connected to the GPIB bus and have their Input Trigger Connector connected to the Output Trigger Connector of the Agilent 8164A/B Lightwave Measurement System mainframe.

The following two functions apply to both Lambda Scan and Multi Frame Lambda Scan applications:

- The Set Lambda Scan Wavelength (`hp816x_set_LambdaScan_wavelength`) function allows you to use a different wavelength than 1550 nm during a Lambda Scan operation. All Power Meters taking part in the Lambda Scan operation will be set to the chosen wavelength.
- The Enable High Sweep Speed (`hp816x_enableHighSweepSpeed`) function enables/disables the highest available sweep speed (40 nanometers per second) for Lambda Scan operations. The Lambda Scan operation chooses the highest possible sweep speed for the chosen step size.
 - If you choose Enable, the highest sweep speed possible will be used. This may lead to less accurate measurements.
 - If you choose Disable, the highest sweep speed will not be used.

Equally Spaced Datapoints

A linear interpolation is performed on all wavelength and power data for the Lambda Scan Application and is optional for the Multi Frame Lambda Scan Application.

The advantage of spacing all measurements equally is that presenting results through use of a spreadsheet is greatly simplified. The operation returns one wavelength array and a power array for each power meter channel.

The disadvantage of using equally spaced datapoints is that the linear interpolation is analogous to the use of a low pass filter. Figure 18 shows the original curve as measured directly by a Power Meter and the interpolated curve.

Interpolation will always tend to produce a smoother curve by rounding off any peaks in the curve.

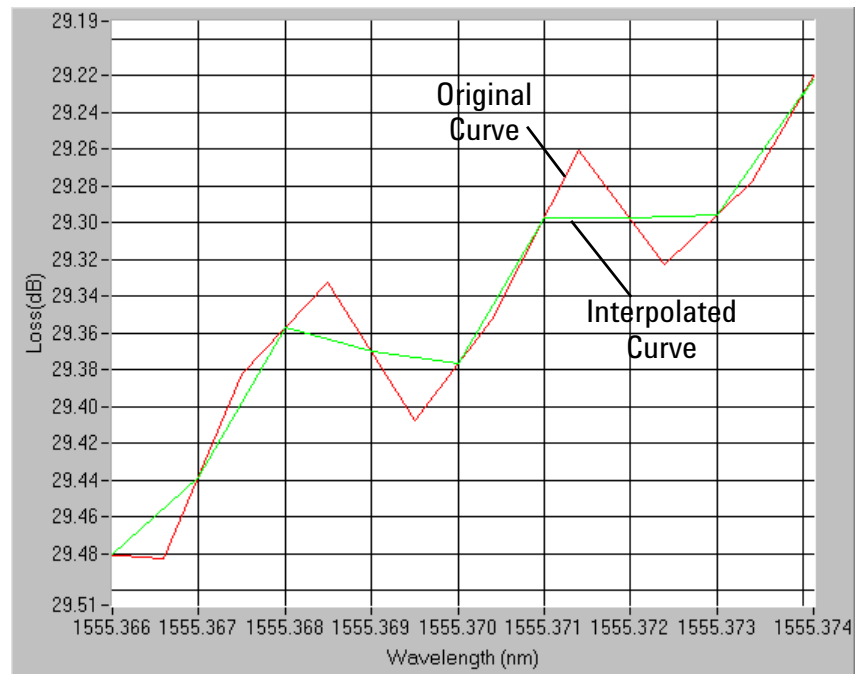

Figure 18 Equally Spaced Datapoints

How to Perform a Lambda Scan Application

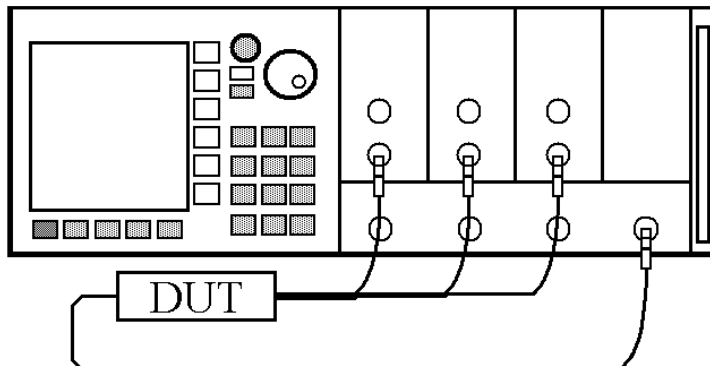

Figure 19 Lambda Scan Operation Setup

The Prepare Lambda Scan Function

The Prepare Lambda Scan (`hp816x_prepareLambdaScan`) function prepares a Lambda Scan operation.

The Prepare Lambda Scan (`hp816x_prepareLambdaScan`) function must be called before a Lambda Scan operation is executed. Use the return values of this function (Number of Datapoints and Number of Power Arrays) to allocate arrays for the Execute Lambda Scan (`hp816x_executeLambdaScan`) function.

To obtain a higher precision, the Tunable Laser Source is set 1 nm before the Start Wavelength, this means, you have to choose a Start Wavelength 1 nm greater than the minimum possible wavelength. Also, the wavelength sweep is actually started 90 pm before the Start Wavelength and ends 90 pm after the Stop Wavelength, this means, you have to choose a Stop Wavelength 90 pm less than the maximum possible wavelength.

Triggers coordinate the Tunable Laser module with all Power Meters. The function sets for the lowest possible averaging time available for the installed Power Meters and, then, sets the highest possible sweep speed for the selected Tunable Laser module sweep.

If one of the following circumstances occurs, the "parameter mismatch" error will be returned:

- 1 If one Power Meter is out of the specification at 1550 nm, the error "powermeter wavelength does not span 1550nm" will be returned. For example, the HP 81530A Power Sensor and the HP 81520A Optical Head are out of specification at 1550 nm. Remove the Power Meter that is out of specification at 1550 nm from the mainframe.

- 2 If the Step Size is too small and results in a trigger frequency that is too high for the installed Power Meters, the error "could not calculate a sweep speed!" will be returned. Increase the Step Size.
- 3 If the chosen wavelength range is too large and Step Size is too small, the error "too many datapoints to log!" will be returned. In this case, reduce the wavelength range and/or increase the Step Size.

The Get Lambda Scan Parameters Function

The Get Lambda Scan Parameters

(hp816x_getLambdaScanParameters_Q) function returns all parameters that the Prepare Lambda Scan (hp816x_prepareLambdaScan) function adjusts or automatically calculates.

The Execute Lambda Scan Function

The Execute Lambda Scan (hp816x_executeLambdaScan) function runs and returns the results of a Lambda Scan operation.

That is, it executes an operation where a Agilent 8164A/B Lightwave Measurement System with a back-loadable Tunable Laser module and up to four Power Sensors installed, performs a wavelength sweep where the Tunable Laser module and Power Sensors are coordinated with each other.

The Prepare Lambda Scan (hp816x_prepareLambdaScan) function must be called before a Lambda Scan operation is executed. Use the return values of this function (Number of Datapoints and Number of Power Arrays) to allocate arrays for the Execute Lambda Scan (hp816x_executeLambdaScan) function.

Equally Spaced Datapoints is enabled as part of this function and cannot be disabled. Use Multi Frame Lambda Scan if you need to have inequally spaced datapoints. See "*Equally Spaced Datapoints*" on page 236 for more details.

How to Perform a Multi-Frame Lambda Scan Application

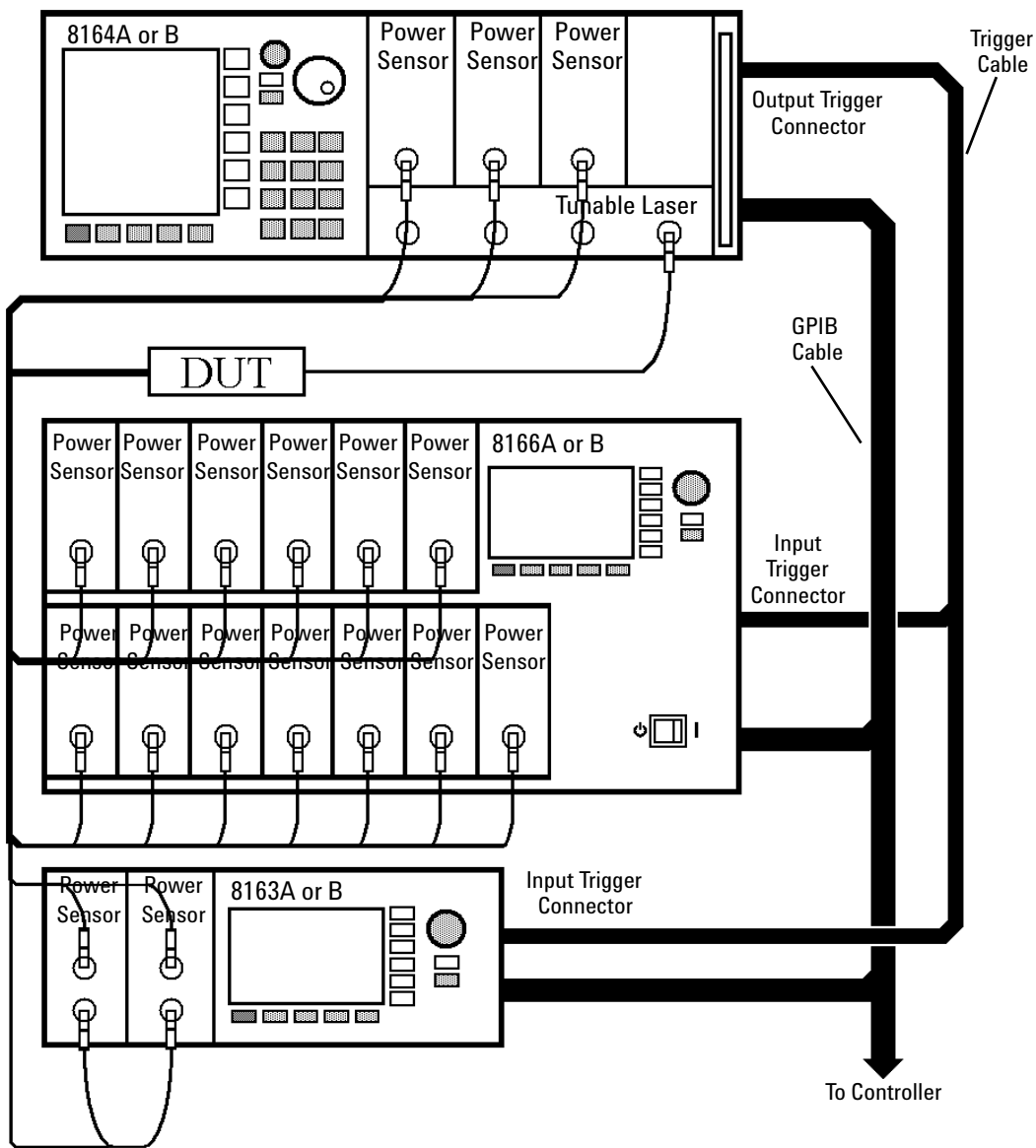

Figure 20 Multi Frame Lambda Scan Operation Setup

The Equally Spaced Datapoints Function

The Equally Spaced Datapoints (`hp816x_returnEquidistantData`) function allows you to select whether the results will be equally spaced by performing a linear interpolation on the wavelength point and power measurement data, see *“Equally Spaced Datapoints” on page 236* for more details.

This function is used because Lambda Scan functions make use of Lambda Logging to log the exact wavelength that measurements were triggered at. This results in Lambda Array wavelength points that are not equally spaced.

NOTE

Lambda Logging is not available if your Tunable Laser module firmware revision is lower than 2.0.

Equally Spaced Datapoints is enabled as a default.

The Register Mainframe Function

Use the Register Mainframe (`hp816x_registerMainframe`) function to register your mainframe as a participant in a Multi Frame Lambda Scan operation. The mainframe must be connected to the GPIB bus and have their Input Trigger Connector connected to the Output Trigger Connector of the Agilent 8164A/B Lightwave Measurement System mainframe that the Tunable Laser module is installed in.

The Unregister Mainframe Function

Use the Unregister Mainframe function (`hp816x_unregisterMainframe`) to remove a mainframe from a Multi Frame Lambda Scan operation and clear the driver's internal data structures.

If you use LabView 5.0 the following items should be noted:

- All multi frame functions are not re-entrant, if the driver is running and initialized more than once, results may be unpredictable.
- To avoid wrong results, call the Unregister Mainframe function prior to the Initialize function (`hp816x_init`). This is especially necessary during program debugging, if the Close function (`hp816x_close`) is not called.

The Prepare Multi Frame Lambda Scan Function

The Prepare Multi Frame Lambda Scan (`hp816x_prepareMfLambdaScan`) function prepares a Lambda Scan operation for multiple Mainframes.

That is, it prepares an operation where a Agilent 8164A/B Lightwave Measurement System with a back-loadable Tunable Laser module and up to 100 Power Meter Channels located in different Mainframes are installed. The function performs a wavelength sweep where the Tunable Laser module and Power Sensors are co-ordinated with each other.

The Prepare Multi Frame Lambda Scan (`hp816x_prepareMfLambdaScan`) function must be called before a Multi Frame Lambda Scan is executed. Use the return values of this function (Number of Datapoints and Number of Power Arrays) to allocate arrays for the Execute Multi Frame Lambda Scan (`hp816x_executeMfLambdaScan`) function.

The function scans all mainframes to find back-loadable Tunable Laser Sources. The function scans each mainframe in the order that they were originally registered by the Register Mainframe function (`hp816x_registerMainframe`). The first back-loadable Tunable Laser Source found will perform the sweep operation.

To obtain a higher precision, the Tunable Laser Source is set 1 nm before the Start Wavelength, this means, you have to choose a Start Wavelength 1 nm greater than the minimum possible wavelength. Also, the wavelength sweep is actually started 90 pm before the Start Wavelength and ends 90 pm after the Stop Wavelength, this means, you have to choose a Stop Wavelength 90 pm less than the maximum possible wavelength.

Triggers coordinate the Tunable Laser module with all Power Meters. The function sets for the lowest possible averaging time available for the installed Power Meters and, then, sets the highest possible sweep speed for the selected Tunable Laser module sweep. All mainframes must be connected to the GPIB bus and have their Input Trigger Connector connected to the Output Trigger Connector of the Agilent 8164A/B Lightwave Measurement System mainframe that the Tunable Laser module is installed in.

If one of the following circumstances occurs, the "parameter mismatch" error will be returned:

- 1 If one Power Meter is out of the specification at 1550 nm, the error "powermeter wavelength does not span 1550nm" will be returned. For example, the HP 81530A Power Sensor and the HP 81520A Optical Head are out of specification at 1550 nm. Remove the Power Meter that is out of specification at 1550 nm from the mainframe.

- 2 If the Step Size is too small and results in a trigger frequency that is too high for the installed Power Meters, the error "could not calculate a sweep speed!" will be returned. Increase the Step Size.
- 3 If the chosen wavelength range is too large and Step Size is too small, the error "too many datapoints to log!" will be returned. In this case, reduce the wavelength range and/or increase the Step Size.

The Get MF Lambda Scan Parameters Function

The Get MF Lambda Scan Parameters (hp816x_getMFLambdaScanParameters_Q) function returns all parameters that the Prepare Multi Frame Lambda Scan (hp816x_prepareMfLambdaScan) function adjusts or automatically calculates.

The Execute Multi Frame Lambda Scan Function

The Execute Multi Frame Lambda Scan (hp816x_executeMfLambdaScan) function runs a Lambda Scan operation and returns an array that contains the wavelength values at which power measurements are made.

That is, it executes an operation where a Agilent 8164A/B Lightwave Measurement System with a back-loadable Tunable Laser module and up to 100 Power Sensors installed, performs a wavelength sweep where the Tunable Laser module and Power Sensors are coordinated with each other.

Use the values returned from the Prepare Multi Frame Lambda Scan (hp816x_prepareMfLambdaScan) function to set the parameters of the Execute Multi Frame Lambda Scan (hp816x_executeMfLambdaScan) function.

The Get Lambda Scan Result Function

The Get Lambda Scan Result (hp816x_getLambdaScanResult) function returns for a given Power Meter channel a power value array and a wavelength value array.

These arrays contain the results of the last Multi Frame Lambda Scan operation.

The Get Number of PWM Channels Function

The Get Number of PWM Channels (hp816x_getNoOfRegPWMChannels_Q) function returns the number of Power Meter channels in a test setup.

Only Power Meters whose mainframe was registered using the Register Mainframe (hp816x_registerMainframe) function are counted.

The Get Channel Location Function

The Get Channel Location function (hp816x_getChannelLocation_Q) returns the location of the chosen Power Meter channel as used in a Multi Frame Lambda Scan operation.

The maximum number of channels that may be specified is 1000.

8

GPIB Command Compatibility List

This chapter gives information about adapting programs developed for use with HP 8153A Lightwave Multimeter or HP 8167B/8D/8E/8F Tunable Laser Source.

Compatibility Issues.....	246
GPIB Bus Compatibility.....	246
Status Model.....	247
Preset Defaults.....	248
Removed Command.....	249
Obsolete Commands.....	250
Changed Parameter Syntax and Semantics.....	251
Changed Query Result Values.....	252
Timing Behavior.....	253
Error Handling.....	254
Command Order.....	255
Instrument Status Settings.....	256

Compatibility Issues

For each table entry in this chapter, it is noted whether the compatibility change affects either:

- the HP 8153A Lightwave Multimeter - 8153,
- the HP 8167B/8D/8E/8F Tunable Laser Source - 8167/8, or
- both of these instruments - Both.

GPIB Bus Compatibility

These commands are incompatible.

Table 10 Incompatible GPIB Bus Commands

Command	Change	Affects
LLO - local lockout		Both
DCL - device clear		Both
GET - group execute trigger		Both

Status Model

The status model is completely incompatible with the HP 8153A and HP 8167/8.

Preset Defaults

The preset defaults are different.

Removed Command

Table 11 contains details of commands that have been removed without replacement.

Table 11 Removed Commands

Command	Change	Affects
*SRE/?	No support for this command/query.	Both
*TRG	No support for triggered commands.	8153
ABORt	This command is not supported; in every case, the bus is blocked during command execution.	8153
STATus:OPERation: NTRansition/?	These status model features are not supported.	8153
STATus:OPERation: PTRansition/?		
STATus:QUEStionable: NTRansition/?		
STATus:QUEStionable: PTRansition/?		
SYSTem:BEEPer:STATe/?	Beeper access is not supplied.	8153
*SAV *RCL	User interface or GPIB settings cannot be stored or recalled.	8167/8
BDATA? DOSMODE/?	Memory card access is not provided.	8167/8
TRACe:CATalog? TRACE:DATA? TRACE:POINts?	The TRACe tree is not supported; the CC_UNCAL curve does not exist.	8167/8
WAVEACT	Alignment to external wavemeter is not supported.	8167/8
misc 200	Risetime control is not supported yet.	8167/8

Obsolete Commands

Table 12 contains details of commands that have been directly replaced.

Table 12 Obsolete Commands

Old Command	New Command	Affects
DISPlay:STATe/?	DISPlay:ENABle/?	8153
PROGram command tree	SENSe:FUNcTion command tree. Some commands from the PROGram command tree have not been replaced. The HP 8153A application interface on the GPIB is not supported. Stability/Logging and Min/Max are available via a new interface.	8153
Return Loss Module Commands	The commands for the return loss modules will be completely different than those for the HP 8153A.	8153

Changed Parameter Syntax and Semantics

Table 13 details commands whose parameter syntax or semantics have changed.

Table 13 Commands with Different Parameters or Syntax

Command	Change	Affects
SOUR:AM:FREQ/?	This command does not accept the value CW, instead use SOUR:AM:STAT ON OFF to switch from and to CW mode. The commands accepts floating point values.	8153
DISP:BRIG	This command now supports integers between 1 and 100, instead of float values between 1 and 0.	8153
SENS:CORR:COLL:ZERO?	This command returns the last zero state, instead of the last remote zero state.	8153
SENS:POW:REF	Accepts TOMODule and TOREF for the first parameter, instead of accepting TOA TOB as the HP 8153A does. The numbers 0 1 2 cannot be used, only the strings above.	8153
SENS:POW:REF:STAT:RAT	Accepts TOREF,0 or values for slot,channel, instead of accepting TOA TOB as the HP 8153A does. The numbers have a different meaning.	8153
SYST:DATE	SYST:DATE from HP 8167/8 is not supported, but SYST:DATE from HP 8153 is supported.	8167/8

Changed Query Result Values

Table 14 details queries that respond with different return codes than the old instruments.

Table 14 Queries with Different Result Values

Command	Change	Affects
*IDN?	Returns new instrument and module identifiers.	Both
*OPT?	Returns new module options.	Both
*TST	Selftest result codes are completely new. 0 still means passed.	Both
	A head adapter is not overwritten with the head when it is inserted.	8153
SENS:POW:UNIT?	Returns W DBM not a number.	8153
SOUR:POW:WAV?	Returns LOW UPP BOTH EXT and not the wavelength; use SOUR:WAV? to query the wavelength. SOUR:WAV:FIXED1? returns the wavelength of the first laser and SOUR:WAV:FIXED2? returns the wavelength of the second laser. For the HP 8153A, SOUR:POW:WAV? returned the wavelength of the active laser.	8153
SYSTem:ERRor?	Same functionality but different numbers and errors are returned for instrument specific errors.	8153
SOURce:AM:SOURce?	Returns different enum values than the HP 8167/8.	8167/8

Timing Behavior

Table 15 details the ways in which timing behavior is different.

Table 15 Timing Behavior Changes

Change	Affects
<p>Command execution may be different.</p> <p>In all mainframes and modules firmware revisions before 3.x GPIB will block during command execution, except when executing functions, such as logging and sweep, that don't tolerate blocking. This is identical to the behavior of the 8167/8. A side effect of this is that *OPC? always returns 1.</p> <p>In later firmware revisions GPIB only blocks if a command can't be processed because of a pending command. While a command is pending *OPC? returns 0 now. This is the behaviour of the 8153.</p> <p>When continuous triggering and averaging times are greater than 1 second, the read-out values reset after the averaging time is over; there is no sliding behavior.</p>	<p>Both</p> <p>Both</p> <p>8153</p>

Error Handling

Most error commands and error texts for all instruments are new.

The HP 8153A timed out for every error. Errors are handled differently by the Agilent 8163A/B and 8164A/B; instead of timing out for every error, special values are returned for erroneous queries. Table 16 and Table 17 detail the new errors

The error queue is written to as before.

Table 16 Error Handling Changes

Expected Return Value	Returned Value	Affects
FLOAT(32/64)	FLT/DBL_MAX	8153
(U)INT(16/32)	(U)INT(16/32)_MAX	8153
Block	" "	8153
Boolean Value	0	8153
Enum	Time out	8153

Table 17 Specific Errors

Command	Change	Affects
FETCh:POWer? - without using a preceding trigger	Returns the last valid value instead of timing out. No error is generated.	8153

Command Order

It is not yet known if there are any changes in the command order behavior.

Instrument Status Settings

The trigger configuration automatically overrides other instrument setting and control capabilities. This applies to both the HP 8153A and HP 8167/8.



9

Error Codes

This chapter gives information about error codes used with the Agilent 8163A/B Lightwave Multimeter, the Agilent 8164A/B Lightwave Measurement System, and the Agilent 8166A/B Lightwave Multichannel System.

[GPIB Error Strings258](#)

GPIB Error Strings

Error strings in the range -100 to -183 are defined by the SCPI standard, downloadable from: <http://www.scpiconsortium.org/scpistandard.htm>

String descriptions taken from this standard (VERSION 1999.0 May, 1999), whether in whole or in part, are enclosed by [].

Table 18 Overview for Supported Strings

New/Old/Standard	Error	
	Number	String
Note:	Error strings in the range -100 to -183 are defined by the SCPI standard, downloadable from: http://www.scpiconsortium.org/scpistandard.htm String descriptions taken from this standard (VERSION 1999.0 May, 1999), whether in whole or in part, are enclosed by [] in this table.	
-100 to -199 Command Errors		
Standard	-100	"Command Error" [This is the generic syntax error used when a more specific error cannot be detected. This code indicates only that a Command Error as defined in <i>IEEE 488.2, 11.5.1.1.4</i> has occurred.]
Standard	-101	"Invalid character" [A syntactic element contains a character which is invalid for that type; for example, a header containing an ampersand, SETUP&. This error might be used in place of error -114 and perhaps some others.]
Standard	-102	"Syntax error" [An unrecognized command or data type was encountered; for example, a string was received when the device does not accept strings.]
Standard	-103	"Invalid separator" [The parser was expecting a separator and encountered an illegal character; for example, the semicolon was omitted after a program message unit]
Standard	-104	"Data type error" [The parser recognized a data element different than one allowed; for example, numeric or string data was expected but block data was encountered.]
Standard	-105	"GET not allowed" [A Group Execute Trigger was received within a program message (see <i>IEEE488.2, 7.7</i>).]
Standard	-108	"Parameter not allowed" [More parameters were received than expected for the header]

Table 18 Overview for Supported Strings

New/Old/Standard	Error	
	Number	String
Standard	-109	"Missing parameter" [Fewer parameters were recieved than required for the header]
Standard	-112	"Program mnemonic too long" [The header contains more than twelve characters (see <i>IEEE 488.2</i> , 7.6.1.4.1).]
Standard	-113	"Undefined header" [The header is syntactically correct, but it is undefined for this specific device ; for example, *XYZ is not defined for any device.]
Standard	-120	"Numeric data error" [This error, as well as errors -121 through -129, are generated when parsing a data element which appears to be numeric, including the nondecimal numeric types. This error message is used if the device cannot detect a more specific error.]
Standard	-121	"Invalid character in number" [An invalid character for the data type being parsed was encountered; for example, an alpha in a decimal numeric]
Standard	-123	"Exponent too large" [The magnitude of the exponent was larger than 32000 (see <i>IEEE 488.2</i> , 7.7.2.4.1).]
Standard	-124	"Too many digits" [The mantissa of a decimal numeric data element contained more than 255 digits excluding leading zeros (see <i>IEEE 488.2</i> , 7.7.2.4.1).]
Standard	-128	"Numeric data not allowed" [A legal numeric data element was received, but the device does not accept one in this position for the header.]
Standard	-131	"Invalid suffix" [The suffix does not follow the syntax described in <i>IEEE 488.2</i> , 7.7.3.2, or the suffix is inappropriate for this device .]
Standard	-134	"Suffix too long" [The suffix contained more than 12 characters (see <i>IEEE 488.2</i> , 7.7.3.4).]
Standard	-138	"Suffix not allowed" [A suffix was encountered after a numeric element which does not allow suffixes.]
Standard	-141	"Invalid character data" [Either the character data element contains an invalid character or the particular element received is not valid for the header.]
Standard	-148	"Character data not allowed" [A legal character data element was encountered where prohibited by the device .]

Table 18 Overview for Supported Strings

New/Old/Standard	Error	
	Number	String
Standard	-150	<p>"String data error"</p> <p>[This error, as well as errors -151 through -159, are generated when parsing a string data element. This error message is used when the device cannot detect a more specific error.]</p>
Standard	-151	<p>"Invalid string data"</p> <p>[A string data element was expected, but was invalid for some reason (see <i>IEEE 488.2, 7.7.5.2</i>); for example, an END message was received before the terminal quote character.]</p>
Standard	-158	<p>"String data not allowed"</p> <p>[A string data element was encountered but was not allowed by the device at this point in parsing.]</p>
Standard	-161	<p>"Invalid block data"</p> <p>[A block data element was expected, but was invalid for some reason (see <i>IEEE 488.2, 7.7.6.2</i>); for example, an END message was received before the length was satisfied.]</p>
Standard	-168	<p>"Block data not allowed"</p> <p>[A legal block data element was encountered but was not allowed by the device at this point in parsing.]</p>
Standard	-170	<p>"Expression error"</p> <p>[This error, as well as errors -171 through -179, are generated when parsing an expression data element. This particular error message is used when the device cannot detect a more specific error.]</p>
Standard	-171	<p>"Invalid expression"</p> <p>[The expression data element was invalid (see <i>IEEE 488.2, 7.7.7.2</i>); for example, unmatched parentheses or an illegal character.]</p>
Standard	-178	<p>"Expression data not allowed"</p> <p>[A legal expression data was encountered but was not allowed by the device at this point in parsing.]</p>
Standard	-181	<p>"Invalid outside macro definition"</p> <p>[Indicates that a macro parameter placeholder (\$<number>) was encountered outside of a macro definition.]</p>
Standard	-183	<p>"Invalid inside macro definition"</p> <p>[Indicates that the program message unit sequence, sent with a *DDT or *DMC command, is syntactically invalid (see <i>IEEE 488.2, 10.7.6.3</i>).]</p>

Table 18 Overview for Supported Strings

New/Old/Standard	Error	
	Number	String
New	-185	<p>"Subop out of range"</p> <p><i>Description:</i></p> <p>Suboperations are parameters that are passed to refine the destination of a command. They are used to address slots, channels, laser selections and GPIB/SCPI register levels. This error is generated if the parameter is not valid in the current context or system configuration.</p> <p><i>Example:</i></p> <p>This error occurs if the user queries the status of a summary register and passes an invalid status level (also see "Status for 816x" on page 28 programmer's guide).</p> <p><i>Note:</i></p> <p>Incorrect slots and channels addresses are handled by error code -301</p>
-200 to -299 Execution Errors		
Standard	-200	<p>"Execution error (StatExecError)"</p> <p><i>Description:</i></p> <p>This error occurs when the current function, instrument or module state (or status) prevents the execution of a command. This is a generic error which can for a number of reasons.</p> <p><i>Example:</i></p> <p>When a powermeter has finished a logging application and data is available, the user is not able to reconfigure the logging application parameters. First, the user must stop the logging application.</p>
New	-201	<p>"Please be patient - GPIB currently locked out"</p> <p><i>Description:</i></p> <p>Some operations block the complete system. Since no sensible measurements are possible while this is true, the GPIB is locked out.</p> <p><i>Example:</i></p> <p>When ARA, Lambda zeroing or zeroing is executing on a TLS module, the GPIB is not accessible.</p>
New	-205	<p>"Powermeter not running (StatMeterNotRunning)"</p> <p><i>Description:</i></p> <p>Some command and actions may stop the data acquisition unit of a powermeter. If a command fetches data, there may be no measurement values and this error is generated. Please check module state and repeat operation.</p>

Table 18 Overview for Supported Strings

New/Old/Standard	Error	
	Number	String
Old	-211	<p>"Trigger ignored"</p> <p><i>Description:</i></p> <p>A trigger has been detected but ignored because of timing constraints. (For Example: average time to large).</p>
Old	-212	<p>"Arm ignored"</p> <p><i>Description:</i></p> <p>The user can set the automatic re-arming option for input and output trigger events (see "Triggering - The TRIGger Subsystem" on page 171). When this error occurs, the device ignores the setting because the current module status does not allow the change of trigger settings.</p>
Old	-213	<p>"Init ignored"</p> <p><i>Description:</i></p> <p>The INIT:IMM command (page 88) initiates a trigger and completes a full measurement cycle. The continuous measurement must be DISABLED. This error code is generated if the powermeter is still in cont. measurement mode.</p>
Old	-220	<p>"Parameter error (StatParmError)"</p> <p><i>Description:</i></p> <p>The user has passed a parameter that cannot be changed in this way. The device cannot detect one of the following more specific errors:</p>
Old	-220	<p>-220, "Parameter error (StatParmOutOfRange)"</p> <p><i>Description:</i></p> <p>The user has passed a parameter that exceeds the valid range for this parameter.</p>
Old	-220	<p>"Parameter error (StatParmIllegalVal)"</p> <p><i>Description:</i></p> <p>The user has passed a parameter that does not match a value in a list of possible values.</p>

Table 18 Overview for Supported Strings

New/Old/Standard	Error	
	Number	String
Old	-221	<p>"Settings conflict (StatParmInconsistent)"</p> <p><i>Description:</i></p> <p>The user has passed a parameter that conflicts with other already configured parameters.</p> <p><i>Example:</i></p> <p>There are constraints for TLS sweep parameters: this error is generated when lambda step size exceeds the difference between start and stop wavelength.</p> <p>If error -221 is returned after you try to start a wavelength sweep, one of the following cases of sweep parameter inconsistency has occurred:</p> <p>Continuous Sweep mode AND I Start is less than I Stop.</p> <p>Continuous Sweep mode AND Sweep Time is too short. Adjust Sweep Speed, I Start, or I Stop.</p> <p>Continuous Sweep mode AND Sweep Time is too long. Adjust Sweep Speed, I Start, or I Stop.</p> <p>Continuous Sweep mode AND Trigger Frequency is too high. Adjust Step Size. Trigger Frequency is the Sweep Speed divided by the Step Size.</p> <p>Stepped Sweep mode AND Lambda Logging Enabled.</p> <p>Continuous Sweep mode AND Lambda Logging Enabled AND Output trigger mode not set to STFinished (Step finished).</p> <p>Continuous Sweep mode AND Lambda Logging is Enabled AND Modulation Source is not set to OFF.</p> <p>Continuous Sweep mode AND Lambda Logging is Enabled AND Sweep Cycles is not set to 1.</p> <p>Continuous Sweep mode AND Coherence Control is Enabled.</p>
Standard	-222	<p>"Data out of range (StatParmTooLarge)"</p> <p><i>Description:</i></p> <p>The user has passed a continuous parameter that is too large.</p> <p><i>Example:</i></p> <p>Wavelength 1800nm when maximum wavelength is 1700nm.</p>
Standard	-222	<p>"Data out of range (StatParmTooSmall)"</p> <p><i>Description:</i></p> <p>The user has passed a continuous parameter that is too small.</p> <p><i>Example:</i></p> <p>Wavelength 700nm when minimum wavelength is 800nm.</p>

Table 18 Overview for Supported Strings

New/Old/Standard	Error	
	Number	String
Standard	-223	<p>"Too much data"</p> <p><i>Description:</i></p> <p>A function returns more data or the user requests more data than the application is able to handle.</p> <p><i>Example:</i></p> <p>A tunable laser source produces more data when lambda values of a sweep are stored than the 816x instrument is able to handle. Use the new SENSE:FUNC:RES:BLOCK? command to split the data acquisition into multiple parts.</p>
Standard	-224	<p>"Illegal parameter value"</p> <p>[Used where exact value, from a list of possibles, was expected.]</p>
New	-225	<p>"Out of memory"</p> <p><i>Description:</i></p> <p>The request application or function cannot be executed because the instrument runs out of memory.</p>
Old	-231	<p>"Data questionable (StatValNYetAcc)"</p> <p><i>Description:</i></p> <p>The data that is returned is not accurate or reliable. The user should repeat the operation. The reason for this error is unspecific.</p> <p><i>Example:</i></p> <p>A powermeter configured a long average time has not completed its current measurement cycle when the user queries the current power.</p>
Old	-231	<p>"Data questionable (StatRangeTooLow)"</p> <p><i>Description:</i></p> <p>As -231 (StatValNYetAcc) but for a more specific reason: The powermeter readout data is not reliable because the currently set (manual) range does not correspond with the input power.</p>
Old	-261	<p>"Math error in expression (StatUnitCalculationError)"</p> <p><i>Description:</i></p> <p>This may occur when the user attempts to transform data in a way that is currently not possible.</p> <p><i>Example:</i></p> <p>When a powermeter is measuring very small power values in dBm (such as noise power), negative power values in Watt may also be present (such as when the powermeter calibration wavelength does not correspond to the wavelength of input signal). The instrument cannot transform negative Watt values to dBm because the logarithm of a negative value is not defined.</p>

Table 18 Overview for Supported Strings

New/Old/Standard	Error	
	Number	String
Standard	-272	<p>"Macro execution error"</p> <p>[Indicates that a syntactically legal macro program data sequence could not be executed due to some error in the macro definition (see <i>IEEE 488.2</i>, 10.7.6.3.)]</p>
Standard	-273	<p>"Illegal macro label"</p> <p>[Indicates that the macro label defined in the *DMC command was a legal string syntax, but could not be accepted by the device (see <i>IEEE 488.2</i>, 10.7.3 and 10.7.6.2); for example, the label was too long, the same as a common command header, or contained invalid header syntax.]</p>
Standard	-276	<p>"Macro recursion error"</p> <p>[Indicates that a syntactically legal macro program data sequence could not be executed because the device found it to be recursive (see <i>IEEE 488.2</i>, 10.7.6.6.)]</p>
Standard	-277	<p>"Macro redefinition not allowed"</p> <p>[Indicates that a syntactically legal macro label in the *DMC command could not be executed because the macro label was already defined (see <i>IEEE 488.2</i>, 10.7.6.4.)]</p>
Standard	-278	<p>"Macro header not found"</p> <p>[Indicates that a syntactically legal macro label in the *GMC? query could not be executed because the header was not previously defined.]</p>
Old	-284	<p>"Function currently running (StatModuleBusy)"</p> <p><i>Description:</i></p> <p>This error is generated when a function is currently running on a module so that it cannot process another commands.</p> <p><i>Example:</i></p> <p>When a powermeter is running a logging application, you are not able to configure the logging application parameters (also see -200).</p>
Old	-286	<p>"No function currently running"</p> <p><i>Description:</i></p> <p>This error is generated when a user tries to execute a command which requires a particular set of data that is not available.</p> <p><i>Example:</i></p> <p>Application data is necessary to execute SENSE:FUNC:RES?. If no suitable function has completed, there is no data and this error is generated. (also see -200).</p>

Table 18 Overview for Supported Strings

New/Old/Standard	Error	
	Number	String
New	-290	<p>"Application currently running - no GPIB support"</p> <p><i>Description:</i></p> <p>The instrument has built-in applications that have no GPIB support (such as Logging,Stability,PACT).</p> <p><i>Example</i></p> <p>When an application is running error -290 will be returned if any command other than one the following is sent:</p> <p>*WAI</p> <p>*OPC?</p> <p>:SPECial:REBoot</p> <p>:SYSTem:ERRor?</p> <p>:SYSTem:VERSion?</p>
-300 to -399 or between 1 and 32767 Device-Specific Errors (Module)		
Old	-300	<p>"Internal error (StatVals Lost)"</p> <p>"Internal error (StatInternalError)"</p> <p><i>Description</i></p> <p>These are generic device-dependent errors used when the instrument cannot detect more specific errors.</p>
New	-301	<p>"Module doesn't support this command (StatCmdUnknown)"</p> <p><i>Description:</i></p> <p>The addressed module does not support the SCPI command.</p> <p><i>Example:</i></p> <p>When a command from the SENSE SCPI tree is sent to a fixed or tunable laser source.</p>
New	-302	<p>"Internal timeout error (StatTimedOut)"</p> <p><i>Description:</i></p> <p>A command has not returned in the expected time.</p>
New	-303	<p>"Module slot empty or slot / channel invalid"</p> <p><i>Description:</i></p> <p>The user has send a command to an empty slot.</p>
New	-304	<p>"Command was aborted (StatAborted)"</p> <p><i>Description:</i></p> <p>The command has been interrupted by another event.</p>

Table 18 Overview for Supported Strings

New/Old/Standard	Error	
	Number	String
New	-305	"Internal messaging error (StatCmdError)" "Internal messaging error (StatCmdNotAllowed)" "Internal messaging error (StatWrongLength)" "Internal messaging error (StatWrongReceiver)" "Internal messaging error (StatBufAllocError)" "Internal messaging error (StatDPRamFull)"; } "Internal messaging error (StatSemError)" <i>Description:</i> An error has occurred in the instrument communication system. Please report this error with a description of the circumstances that generated the error and the configuration of the system.
New	-306	"Channel doesn't support this command (StatCmdUnknownForSlave)" <i>Description:</i> Slave channels have limited functionality. The module supports this command, but the command must be sent to the master channel.
New	-307	"Channel without head connection (StatHeadless)" <i>Description:</i> The channel supports this command, but it cannot be executed because the optical measurement head is not plugged into the interface module.
Standard	-310	"System error" [Indicates that some error, termed "system error" by the device, has occurred. This code is device-dependent.]
Standard	-321	"Out of memory" [An internal operation needed more memory than was available.]
New	-322	"Flash programming error (StatFlashEraseFailed)" "Flash programming error (StatFlashWriteFailed)" "Flash programming error (StatFlashDataCntError)" "Flash programming error (StatFlashDPAIgoFailed)" <i>Description:</i> An error has occurred in a module. Please report this error with a description of the circumstances that generated the error and the configuration of the system.

Table 18 Overview for Supported Strings

New/Old/Standard	Error	
	Number	String
New	-323	"Flash programming error (StatUserCalTable Empty)" It is not possible to activate the offset (I) functionality when the offset table is empty "Flash programming error (StatUserCalTable Full)" The offset (I) table is full and no more ? can be stored "Flash programming error (StatUserCalActive)" It is not possible to program the offset (I) table when the offset (I) feature is activated. Deactivate first.
Old	-330	"Self-test failed" <i>Description:</i> You have started the self test, but the module has detected an error while executing it
New	-340	"Printing error (StatPrintError)" <i>Description:</i> An unspecified problem occurred while communicating with the printer.
New	-341	"Printing error - paper out (StatPaperOut)" <i>Description:</i> The instrument cannot print because there is no paper in the connected printer.
New	-342	"Printing error - offline (StatOffline)" <i>Description:</i> The instrument cannot print because the connected printer is offline.
Standard	-350	"Queue overflow" [A specific code entered into the queue in lieu of the code that caused the error. This code indicates that there is no room in the queue and an error occurred but was not recorded.]
-400 to -499 Query Errors		
Standard	-400	"Query error" [This is the generic query error for devices that cannot detect more specific errors. This code indicates only that a Query Error as defined in <i>IEEE 488.2</i> , 11.5.1.1.7 and 6.3 has occurred.]
Standard	-410	"Query INTERRUPTED" [Indicates that a condition causing an INTERRUPTED Query error occurred (see <i>IEEE 488.2</i> , 6.3.2.3); for example, a query followed by DAB or GET before a response was completely sent.]

Table 18 Overview for Supported Strings

New/Old/Standard	Error	
	Number	String
Standard	-420	<p>“Query UNTERMINATED”</p> <p>[Indicates that a condition causing an UNTERMINATED Query error occurred (see <i>IEEE 488.2</i>, 6.3.2.2); for example, the device was addressed to talk and an incomplete program message was received.]</p>
Standard	-430	<p>“Query DEADLOCKED”</p> <p>[Indicates that a condition causing an DEADLOCKED Query error occurred (see <i>IEEE 488.2</i>, 6.3.1.7); for example, both input buffer and output buffer are full and the device cannot continue.]</p>
Standard	-440	<p>“Query UNTERMINATED after indef resp”</p> <p>[Indicates that a query was received in the same program message after an query requesting an indefinite response was executed (see <i>IEEE 488.2</i>, 6.5.7.5).]</p>

Table 19 Overview for Unsupported Strings

New/Old/Standard	Error	
	Number	String
Old	all positive errors	
Old	-110	"Command header error"
Old	-111	"Header separator error"
Old	-114	"Header suffix out of range"
Old	-130	"Suffix error"
Old	-140	"Character data error"
Old	-144	"Character data too long"
Old	-160	"Block data error"
Old	-201	"Invalid while in local"
Old	-202	"Settings lost due to ???"
Old	-210	"Trigger error"
Old	-214	"Trigger deadlock"
Old	-215	"Arm deadlock"
Old	-230	"Data corrupt or stale"
Old	-240	"Hardware error"
Old	-241	"Hardware missing"
Old	-260	"Expression error"
Old	-280	"Program error"
Old	-281	"Cannot create program"
Old	-282	"Illegal program name"
Old	-283	"Illegal variable name"
Old	-285	"Program syntax error"
Old	-286	"Program runtime error"
Old	-311	"Memory error" [checksum or parity]
Old	-312	"Protect user data memory lost"
Old	-313	"Calibration memory lost"
Old	-314	"Save/Recall Memory lost"
Old	-315	"Configuration memory lost"

Index

B

Binary block 26
Brightness 186, 187

C

Channel Numbers 26
Command summary 44
Common commands 29
Compatibility 246
Continuous measurement 88, 89
Contrast 186
Coordination of modules
 example 199

D

Data Types 26
Date 76
Display
 brightness 186, 187
 LCD 187
 Lockout 187
display contrast 186
Display Operations 186
DISPlay Subsystem 186

E

Error handling 230
Error strings
 GPIB 258
Event register
 operation enable 66, 67, 69, 73
 questionable enable 72, 75
Event Status Enable 58
Event Status Register 58

F

FETCh subsystem 87
Fixed Laser Source
 Set up example 192

G

GPIB Interface 16

H

Agilent VEE 218

I

Identification 59
IEEE-Common Commands 56
INITiate subsystem 88
Input queue 20
Installed options 60
Instrument addresses 232
Instrument Behaviour Settings 76
Instrument driver 225
Instrument driver installation 214
Interface
 behaviour settings 76

L

LabView 221
LabWindows 224
Lambda scan
 execute function 238
 get parameters function 238
 get result function 242
 mult-frame 241
 prepare function 237
Lambda scans 235
Laser
 state 127
 switch on 127
Laser Selection Numbers 27
LCD 187
Local control 18
LOCK subsystem 80

M

Measurement
 start 88
Measurement Functions 85
Message queues 19

O

Operation Complete 60
Operation enable 66, 67, 69, 73
Options 60
Output queue 21
OUTPut subsystem 113, 148

P

Power measurement

 example of FETCh and READ usage 195

Power Meter
 continuous measurement 88
 start measurement 88

Power meter
 configure all 90
 continuous measurement 89
 current value 90
 read all 89

Power variation with wavelength 203

Q

Questionable enable 72, 75

R

READ subsystem 91
Register
 Operational Slot Status 38
 Questionable slot status 38
 Standard Event Status 37
 Status byte 37
 Status summary 38
register mainframe 240
Reset 61
Return Loss
 current monitor value 91
 current value 91
Root layer commands 80

S

SCPI revision 78
Self-test 62
SENSe subsystem 92
Signal conditioning 148
Signal conditioning 148
Signal generation 113
Slot Numbers 26
SLOT subsystem 81
SOURce subsystem 113
SPECial subsystem 84
Specific Command Summary 44
Start
 laser 127
 measurement 88
 power meter measurement 88
Status Byte 61
Status Command Summary 40
Status Information 31

Status Reporting 64
STATus subsystem 64
Stop
 laser 127
Subsystem
 DISPlay 186
 FETCh 87
 INITiate 88
 LOCK 80
 OUTPut 113, 148
 READ 91
 SENSe 92
 SLOT 81
 SOURce 113
 SPECial 84
 STATus 64
 SYSTem 76
 TRIGger 171
SYSTem subsystem 76

T

Test 62
Time 78
Trace Data Access 78
TRIGger Subsystem 171

U

Units 25
unregister mainframe 240

V

Visa calls
 How to use 190
VISA data types 229
Visual programming environment 218
Vxipnp directory 226

W

Wait 63
Wavelength dependent offset table 159

www.agilent.com

© Agilent Technologies, Deutschland
GmbH 2002-2005

Fifth edition, January 2005



08164-90B64

