



**Advanced Test Equipment Rentals**  
**www.atecorp.com 800-404-ATEC (2832)**

---

# Agilent Technologies

---

**Advisor VQT Undercradle**

**J4630A**

**Setup Guide**



**Agilent Technologies**

**Copyright**

© Agilent Technologies 2001  
All rights reserved.

**Notice**

The information contained in this document is subject to change without notice.

AGILENT TECHNOLOGIES MAKES NO WARRANTY OF ANY KIND WITH REGARD TO THIS MATERIAL, INCLUDING, BUT NOT LIMITED TO, THE IMPLIED WARRANTIES OF MERCHANTABILITY AND FITNESS FOR A PARTICULAR PURPOSE.

Agilent Technologies shall not be liable for errors contained herein or for incidental or consequential damages in connection with the furnishing, performance, or use of this material.

**Warranty**

A copy of the specific warranty terms applicable to your product and replacement parts can be obtained from your local Sales and Service Office.

**Microsoft®**

is a U.S. registered trademark of Microsoft Corp.

**Windows® and  
MS Windows®**

are U.S. registered trademarks of Microsoft Corp.

**(c) OPTICOM  
Dipl.-Ing. M. Keyhl GmbH  
Erlangen, Germany, 1999**

Perceptual Speech Quality Measurement (PSQM) technology licenced and approved by OPTICOM, and developed (by permission under license) by KPN Research, the Netherlands.  
For more information: <http://www.opticom.de>

**Psytechnics Limited**

Software included in this product is protected by copyright and by European, US and other patents and is provided under license from Psytechnics Limited.

**Printing history**

New editions of this guide are issued to reflect extensive changes made to the software. Revisions may be issued, between editions, to correct errors in the manual. There may not be a new edition issued in conjunction with every software release. The software release, at the date of printing, is noted in the following table.

<b>Part Number</b>	<b>Printing Date</b>	<b>Software Version</b>
5971-2906	July, 2001	4.1

**Product support**

Call your local Agilent Technologies representative, or:

Tel: 1-800-698-0061

Fax: 303-754-4802

or call your local Agilent Sales and Service Office

Agilent Technologies  
5070 Centennial Boulevard  
Colorado Springs, Colorado  
80919-2497

Web: <http://www.agilent.com/comms/onenetworks>

Printed in the U.S.A.

ATTENTION. USE OF THE SOFTWARE IS SUBJECT TO THE AGILENT TECHNOLOGIES SOFTWARE LICENSE TERMS SET FORTH BELOW. USING THE SOFTWARE INDICATES YOUR ACCEPTANCE OF THESE LICENSE TERMS. IF YOU DO NOT ACCEPT THESE LICENSE TERMS, YOU MAY RETURN THE SOFTWARE FOR A FULL REFUND. IF THE SOFTWARE IS BUNDLED WITH ANOTHER PRODUCT, YOU MAY RETURN THE ENTIRE UNUSED PRODUCT FOR A FULL REFUND.

## AGILENT TECHNOLOGIES SOFTWARE LICENSE TERMS

The following License Terms govern your use of the accompanying Software unless you have a separate signed agreement with Agilent Technologies.

License Grant. Agilent Technologies grants you a license to Use one copy of the Software, with the following exception(s):

1. The VQT-Client may be installed on multiple machines; however, each installation requires the purchase of a separate license key.
2. The VQT Literature may be installed on multiple machines.
3. The Adobe Acrobat Reader Installation Kit may be installed on multiple machines.

"Use" means storing, loading, installing, executing or displaying the Software. You may not modify the Software or disable any licensing or control features of the Software. If the Software is licensed for "concurrent use", you may not allow more than the maximum number of authorized users to Use the Software concurrently.

Ownership. The Software is owned and copyrighted by Agilent Technologies or its third party suppliers. Your license confers no title to, or ownership in, the Software and is not a sale of any rights in the Software. Agilent Technologies's third party suppliers may protect their rights in the event of any violation of these License Terms.

Copies and Adaptations. You may only make copies or adaptations of the Software for archival purposes or when copying or adaptation is an essential step in the authorized Use of the Software. You must reproduce all copyright notices in the original Software on all copies or adaptations. You may not copy the Software onto any public network.

No Disassembly or Decryption. You may not disassemble or decompile the Software unless Agilent's prior written consent is obtained. In some jurisdictions, Agilent's consent may not be required for limited disassembly or decompilation. Upon request, you will provide Agilent Technologies with reasonably detailed information regarding any disassembly or decompilation. You may not decrypt the Software unless decryption is a necessary part of the operation of the Software.

Transfer. Your license will automatically terminate upon any transfer of the Software. Upon transfer, you must deliver the Software, including any copies and related documentation, to the transferee. The transferee must accept these License Terms as a condition to the transfer.

Termination. Agilent Technologies may terminate your license upon notice for failure to comply with any of these License Terms. Upon termination, you must immediately destroy the Software, together with all copies, adaptations and merged portions in any form.

Export Requirements. You may not export or re-export the Software or any copy or adaptation in violation of any applicable laws or regulations.

U.S. Government Restricted Rights. The Software and any accompanying documentation have been developed entirely at private expense. They are delivered and licensed as "commercial computer software" as defined in DFARS 252.227-7013 (Oct 1988), DFARS 252.211-7015 (May 1991) or DFARS 252.227-7014 (Jun 1995), as a "commercial item" as defined in FAR 2.101(a), or as "Restricted computer software" as defined in FAR 52.227-19 (Jun 1987)(or any equivalent agency regulation or contract clause), whichever is applicable. You have only those rights provided for such Software and any accompanying documentation by the applicable FAR or DFARS clause or the Agilent standard software agreement for the product involved.

Microsoft Products. Microsoft Products are licensed to you under the Microsoft End User License Agreement (EULA) contained in the Microsoft documentation. Microsoft Products are covered under the Agilent Technologies warranty Statement supplied with the Agilent Products. The warranties in the Microsoft Documentation will not apply.



## Certification

**Agilent Technologies certifies that this product met its published specifications at the time of shipment from the factory. Agilent Technologies further certifies that its calibration measurements are traceable to the United States National Institute of Standards and Technology (formerly National Bureau of Standards), to the extent allowed by that organization's calibration facility, and to the calibration facilities of other International Standards Organization members.**

## Restricted Rights Legend

If Software is for use in the performance of a U.S. Government prime contract or subcontract, Software is delivered and licensed as iCommercial computer softwarei as defined in DFAR 252.227-7014 (June 1995), or as a icommercial itemi as defined in FAR 2.101(a) or as iRestricted computer softwarei as defined in FAR 52.227-19 (June 1987) or any equivalent agency regulation or contract clause. Use, duplication or disclosure of Software is subject to Agilent Technologies' standard commercial license terms, and non-DOD Departments and Agencies of the U.S. Government will receive no greater than Restricted Rights as defined in FAR 52.227-19(c)(1-2) (June 1987). U.S. Government users will receive no greater than Limited Rights as defined in FAR 52.227-14 (June 1987) or DFAR 252.227-7015 (b)(2) (November 1995), as applicable in any technical data.

Before you use this instrument, read the "General Safety Precautions" and "Additional Safety Information" sections. Failure to comply with the precautions or with specific warnings in this book violates safety standards of design, manufacture, and intended use of this instrument. Agilent Technologies assumes no liability for the customer's failure to comply with these requirements.

## General Safety Precautions

The following warnings and operating information are shown in English followed by the French translation.

**WARNING** This product is a Safety Class I instrument with a protective earth terminal.

**WARNING** For protection from electric shock hazard, power cord ground must not be defeated.

### Operating Restrictions

The following general safety precautions must be observed during all phases of operation, service, and repair of this instrument. Failure to comply with these precautions with specific warnings in this manual violate safety standards of design, manufacture, and intended use of this instrument.

### Grounding

To minimize shock hazard, the instrument chassis and cabinet must be connected to an electrical ground. The instrument is equipped with a three-conductor AC power cable compatible with an approved three-contact electrical outlet. The power jack and mating plug of the power cord must meet International Electrotechnical Commission (IEC) safety standards.

### Environment

Do not operate the instrument in the presence of flammable gases or fumes. Operation of any electrical instrument in such an environment constitutes a definite safety hazard.

### Service and Adjustment

Dangerous voltages exist within this instrument. Service and adjustment of this instrument is to be performed only by trained service personnel.

Do not replace components with the power cable connected. Dangerous voltages may be present even when the power cable is disconnected.

Do not perform internal servicing or adjustment unless another person, capable of rendering first aid and resuscitation is present.

## Hazardous Material

Should the LCD be damaged the liquid crystal material can leak. Avoid all contact with this material, especially swallowing. Use soap and water to thoroughly wash all skin and clothing contaminated with the liquid crystal material.

## Unauthorized Service

The installation of substitute parts or the installation of any instrument modification not authorized by Agilent Technologies is specifically forbidden. The performance of such unauthorized service can negate the instrument warranty or any maintenance agreements.

Return the instrument to an Agilent Sales and Service Office for authorized service and repair.

**MISE EN GARDE** Cet appareil répond aux normes de la «Classe de sécurité I» et est muni d'un fil de mise à la terre pour votre protection.

**MISE EN GARDE** Pour prévenir les risques de choc électrique, la broche de mise à la terre du cordon d'alimentation ne doit pas être désactivée.

## Restrictions d'utilisation

L'utilisateur se doit d'observer les mesures de précaution énumérées ci-dessous pour toutes les phases d'utilisation, de service et de réparation de cet appareil. Le fait de ne pas s'y conformer équivaut à ne pas respecter les mises en gardes spécifiques contenues dans ce manuel et constitue une violation des normes de sécurité relatives à la conception, la fabrication et l'utilisation prévue de cet appareil. La société Agilent n'assume aucune responsabilité envers un client qui manquerait de se conformer à ces exigences.

## Mise à la terre

Afin de minimiser les risques de choc électrique, le châssis et le cabinet de l'appareil doivent être mis à la terre. L'appareil est équipé d'un cordon d'alimentation muni d'une fiche homologuée à trois lames, compatible c.a. La prise murale et la

prise femelle de la rallonge électrique doivent respecter les normes de sécurité de la «Commission électrotechnique internationale» (IEC).

#### Environnement

Ne faites pas fonctionner cet appareil en présence de gaz inflammables ou de vapeurs dangereuses. L'utilisation de n'importe quel appareil électrique dans ces conditions constitue un risque élevé pour votre sécurité.

#### Service et ajustement

Des «tensions dangereuses» résident dans cet appareil. Par conséquent, le service et l'ajustement doivent être effectués uniquement par une personne qualifiée.

Ne remplacez pas de composants lorsque le cordon d'alimentation est sous tension. Il pourrait y avoir présence de «tensions dangereuses» même lorsque l'appareil est déconnecté.

Ne faites pas de service interne ou d'ajustement sauf en présence d'une autre personne, capable de prodiguer les premiers soins et de pratiquer la réanimation.

#### Matière dangereuse

Si l'affichage LCD est endommagé, la matière constituant les cristaux liquides peut se répandre. Éviter tout contact avec cette matière, et en particulier ne pas l'avaler. Utiliser de l'eau et du savon pour nettoyer soigneusement la peau et les vêtements qui auraient été contaminés par la matière constituant les cristaux liquides.

#### Service non autorisé

L'installation de pièces étrangères, ou toute modification apportée à l'appareil sans le consentement de Agilent est formellement interdit. Le fait de procéder à de tels modifications sans autorisation pourrait entraîner l'annulation de la garantie de l'appareil ou de tout contrat de service.

Pour un service et des réparations autorisées, retournez l'appareil à un point de vente et service Agilent.

## Additional Safety Information

#### Electric Shock Hazard

Do not remove the system covers. To avoid electric shock, use only the supplied power cords and connect only to properly grounded (3-pin) wall outlets.

#### Explosion Hazard

Do not operate in the presence of flammable gases.

#### Fire Hazard

For continued protection against fire hazard replace only with fuse of same type and rating.

#### Cleaning

To clean the product, use a damp cloth moistened with a mild solution of soap and water. *Do not* use harsh chemicals. *Do not* let water get into the product.

#### Product Damage

Do not use this product when the product shows visible damage, fails to perform, has been stored in unfavorable conditions, or has been subject to severe transport stresses.

Whenever this product has become damaged or wet, make the product inoperative and secure it against any unintended operation. Contact your nearest Agilent Sales office for assistance.



Instruction book symbol - the product will be marked with this symbol when it is necessary for the user to refer to the instruction book in order to protect against damage.



A product marked with this symbol indicates it is a laser product. When necessary, this symbol will be included in the instruction book for the user to refer to in order to protect against personal injury and/or correct product handling.



Indicates potential for electrical shock.

#### WARNING

An operating procedure, practice, etc., that if not correctly followed could result in personal injury or loss of life.

#### CAUTION

An operating procedure, practice, etc., that if not strictly observed, could result in damage to, or destruction of, equipment or software.

This is an Installation Category II product.

This is a Pollution Degree 2 product.

This product is designed for indoor use only.

#### FCC Part 68 Disclaimer

This equipment must not be connected to the telephone network unless it is connected through protective circuitry that is registered pursuant to Part 68 of the Federal Communications Commission rules.

**Introduction**

Information Map ..... 1-4  
Advisor VQT Undercradle Platform..... 1-5  
    Agilent Advisor and VQT Undercradle..... 1-5  
    FXO and E&M Acquisition Hardware ..... 1-5  
    VQT Application ..... 1-6  
Overview of the Agilent VQT Test System..... 1-7  
    VQT System Components..... 1-7  
    How the VQT Tests Voice Quality..... 1-8  
    VQT System Testing Scenarios ..... 1-10  
    Additional Notes on the Operational Modes..... 1-14

**Getting Started**

Setup Process Overview..... 2-3  
Planning VQT Testing Strategy ..... 2-6  
Setting Up the Advisor and VQT Undercradle ..... 2-7  
    Setting Up a New Advisor and VQT Undercradle ..... 2-7  
    Upgrading An Existing Advisor with VQT Undercradle ..... 2-8  
Configuring for Remote/Distributed Testing ..... 2-9  
    IP Network Configuration ..... 2-9  
    IP Network Physical Connection..... 2-10  
    Configuring the Portable Analyzer as a Server ..... 2-10  
    Setting Up the Controlling PC (Agilent Advisor)..... 2-12  
Connecting the VQT Undercradle ..... 2-15  
    FXO and E&M Connections ..... 2-16  
    Ground Connections ..... 2-19  
    Test Environment Examples ..... 2-22  
Starting the VQT Application and Using the Server Setup Tool.... 2-23

**Specifications/Operating Conditions**

FXO/E&M Card Specifications ..... A-2  
    FXO Ports ..... A-2  
    E&M Ports..... A-2  
Operating Conditions ..... A-3

**Declaration of Conformity**

**Software Recovery**

Re-install the Application ..... C-2

---

## Contents



---

# 1

- Information Map, page 1-4
- Advisor VQT Undercradle Platform, page 1-5
- Overview of the Agilent VQT Test System, page 1-7

---

## Introduction

---

# Introduction

Agilent Technologies Advisor VQT Undercradle (J4630A), when used with the Agilent Advisor protocol analyzer, is a portable device that can be locally or remotely controlled to perform voice quality measurements over FXO, E&M, T1, or E1 interfaces. The VQT Advisor's VQT Undercradle is designed to help evaluate voice quality on voice-over-packet and traditional telephony systems.

The VQT Undercradle can be used to perform single-server voice quality testing where measurements are run between its own ports or channels. It can also be used as part of a larger remote/distributed test environment where voice quality measurements are run between multiple VQT devices.

This Setup Guide describes how to set up the Agilent Advisor with the VQT Undercradle to perform both single-server and multiple-server voice quality measurements.

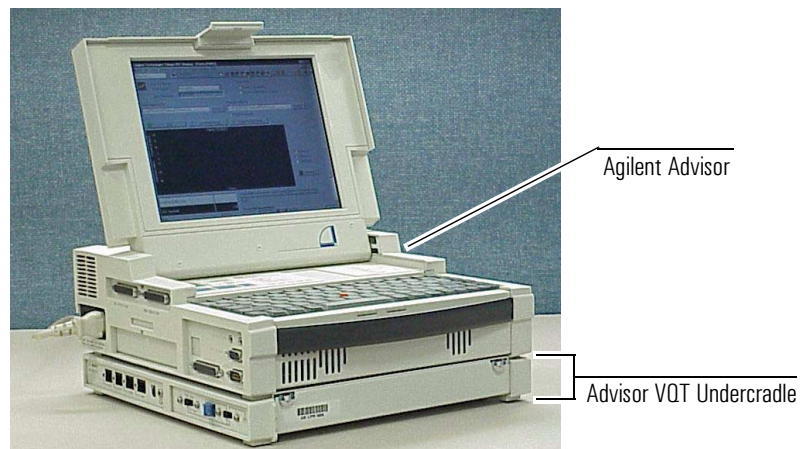

The VQT Undercradle gives you the analysis options for voice-over-packet environments that traditional tests do not.

With the Advisor's VQT Undercradle you can:

- Test voice-over-packet network components such as routers, gateways, PBXs, and switches.
- Directly compare voice-over-packet quality with existing “toll quality” networks.

- Test voice-over-packet systems to gather end-to-end voice quality information.
- Augment other traditional telephony test suites such as TIMS.
- Access, manage, and run VQT tests from a remote location to test voice quality end-to-end across widely deployed voice networks.

The VQT Undercradle provides a broad range of analysis options. You can:

- Measure fundamental voice quality metrics such as clarity and delay.
- Measure echo and evaluate the performance of echo cancellers and measure signal loss across voice circuits.
- Evaluate voice-over-packet operations such as voice activity detection and DTMF tone detection.
- Utilize audio test tools such as tone and noise generation and wave file playback and record.
- Execute simple or complex automated test sequences.

The VQT Undercradle's remote/distributed capabilities provide:

- A client/server architecture for centralized control across most TCP/IP networks.
- Flexible implementation options — You can perform remote/distributed testing or stand-alone testing all with the same equipment.
- Multiple hardware platforms.

The remaining sections of this chapter describe the features of the Advisor VQT Undercradle and voice quality testing concepts in general. To learn how to get started with the VQT Undercradle, go to chapter 2. To get detailed operating instructions for the VQT application, use the VQT's online Help or refer to the *Agilent VQT Getting Started Guide*.

---

## Information Map

This section lists the books and Help that describe Agilent Technologies' VQT test solution. The overall operation of individual VQT servers and the measurements that run on them is described in the documents in the following list:

- Agilent Advisor VQT Undercradle — *VQT Undercradle Setup Guide* (this document) — Refer to chapter 2 to get started quickly.
- VQT Portable Analyzer — *VQT Portable Analyzer Setup Guide*
- VQT Network Server — *VQT Network Sever Setup Guide*
- VQT Software — *Agilent VQT Getting Started Guide* or VQT application's Help

To get started with your new VQT Undercradle, start with the book you are reading now to setup, install, and configure your tester for operation. Then go to the *Agilent VQT Getting Started Guide* or the VQT application's Help for detailed information about running VQT measurements and tools.

---

**Note**

The VQT Software was previously known as the Telegra VQT Application.

---

---

## Advisor VQT Undercradle Platform

The Agilent Technologies Advisor with VQT Undercradle is a rugged, portable, and powerful PC running Windows 98. Standard features include two PCMCIA card slots, floppy drive, and speakers.

The VQT Undercradle is normally controlled through the use of the Advisor's keyboard and monitor. However, the Advisor can be remotely controlled across an IP network by another VQT device or appropriately connected and configured desktop/laptop PC. These connection and configuration options are described in chapter 2.

To perform voice quality measurements, the VQT Undercradle uses one of two test interfaces and is controlled via the VQT application running on the Advisor. These components are described next.

### **Agilent Advisor and VQT Undercradle**

The Agilent Advisor is a world class protocol analyzer that provides WAN, LAN, and ATM analysis for a broad range of physical interfaces and networking protocols. It can be equipped with various interface modules and undercradles, of which the VQT Undercradle is one.

The VQT Undercradle is designed to work in conjunction with the Advisor WAN platform, J2300D, or with the Advisor LAN platform, J3446D. Operating conditions for the VQT Undercradle can be found in Appendix A. Technical information for the Agilent Advisor can be found in its Mainframe Features Guide.

### **FXO and E&M Acquisition Hardware**

This custom analog signal acquisition card is housed in the VQT Undercradle and is the digital signal processing (DSP) engine for the VQT. This card interfaces directly with FXO and E&M devices and systems allowing high accuracy and high resolution measurements. It provides measurement results to the VQT application which displays them in multiple formats. The acquisition hardware's custom design provides flexibility and high performance.

The VQT Undercradle is equipped with several electrical grounding options that increase the reliability of its operation and ensure compliance with domestic and international telecommunication and safety standards. Refer to Ground Connections, page 2-19, for additional information.

### **VQT Application**

The VQT Application is a highly intuitive and easy to use software package installed on the Agilent Advisor and potentially on a desktop/laptop PC if remote control is required. This software leads you through the necessary steps to test voice quality (using the TaskList Navigator), calculates and displays measurement results in both graphical and spreadsheet formats, and provides usage and interpretive information in a multi-mode embedded Help system. In addition, the application can be customized for your unique testing situations with user configurable TaskLists and persistent configuration settings.

Refer to the *Agilent VQT Getting Started Guide* or use the Help for more information on the VQT application.

---

## Overview of the Agilent VQT Test System

The last section described the Agilent Advisor and VQT Undercradle platform. This section provides an overview of the Agilent VQT Test System and the role the VQT Undercradle plays. Refer to the *Agilent VQT Getting Started Guide* or the VQT's online Help for a general description of voice quality testing concepts. Refer to the following sections for more information:

- VQT System Components, page 1-7
- How the VQT Tests Voice Quality, page 1-8
- VQT System Testing Scenarios, page 1-10
- Additional Notes on the Operational Modes, page 1-14

---

## VQT System Components

Fundamentally, the VQT system is broken down into two main components:

- VQT Test Platforms  
The VQT system consists of several hardware platforms of which the Advisor and its VQT Undercradle is one. Each hardware platform contains one or more sets of test interface ports / acquisition cards (described as the “acquisition hardware” in the last section) and analysis software. Depending on the type, these platforms can be locally controlled using their own keyboards and monitors, or remotely controlled using another PC. Other Agilent VQT test platforms include the VQT Network Server and the VQT Portable Analyzer. Both the Portable Analyzer and the Advisor can also be used to remotely control other VQT test devices (including the VQT Network Server).

- VQT Application  
The VQT application is a highly intuitive and easy to use software package that is installed on one of the VQT's test platforms (a VQT Portable Analyzer or the Advisor) or a desktop/laptop PC. Depending on where it is installed and the testing you plan to perform, this application can be run as one or more "clients", each controlling a "VQT server", or as a "server" being controlled by a "client" (the VQT system architecture is described later). This software enables you to manage and secure VQT servers and provides an individual "client window" to run each server when performing remote/distributed testing. In addition, the application can be customized for your unique testing situations with user configurable server scenarios, customizable TaskLists, and persistent configuration settings.

---

## How the VQT Tests Voice Quality

To test voice quality and measure other voice circuit characteristics, the VQT system does two things:

- It places and/or answers one or more telephone calls to establish voice connections. This voice connection (and the transmission media and equipment of which it is comprised) becomes the circuit/system under test. Think of the VQT system as telephones or other telephony devices positioned at the ends of voice circuits.
- Once the VQT system has established at least one telephone call, it transmits audio test signals on to the call and measures how those signals are affected by travel through the circuit/system under test. The VQT can send test signals in either direction on the established circuit regardless of how that circuit was established.

For the VQT system to measure voice quality, it must control one or both ends of a voice circuit (depending on the type of measurement that is run) and be able to actively transmit specific test signals onto that circuit. In many cases, to perform the necessary analysis, the VQT must also be able to receive test signals once they have passed through the circuit under test.

The Advisor and VQT Undercradle (like other VQT devices) can place and answer calls to enable voice quality measurements.



**FXO and E&M  
Environments**

The following diagram illustrates how the VQT Undercradle can play the role of two telephones in an end-to-end test environment.

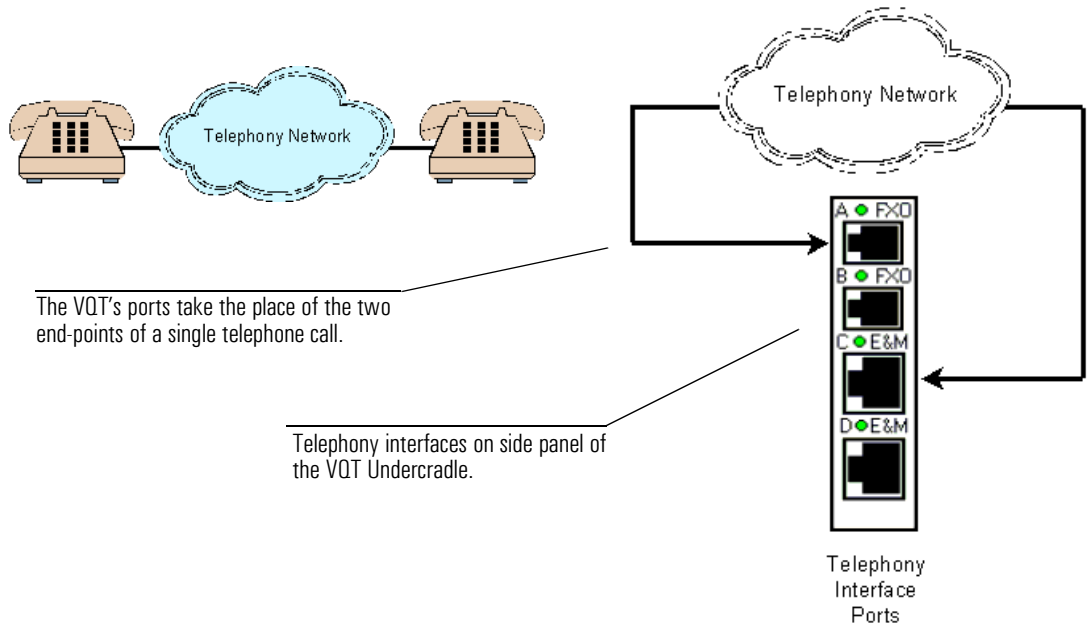

This illustration shows the VQT controlling both ends of a telephone call using the same, single VQT Undercradle. However, the VQT can also be used in “call-only” and “answer-only” modes where one Advisor VQT Undercradle calls another (or other VQT device). Refer to the *Agilent VQT Getting Started Guide* or the VQT’s Help for more information about these test options.

---

## VQT System Testing Scenarios

The VQT system uses a client/server architectural model that supports a number of testing options. You can run voice quality measurements using a single VQT test device (such as the Advisor), or you can implement a collection of locally controlled or remotely controlled test devices that can run measurements between each other. The following illustration shows various examples.

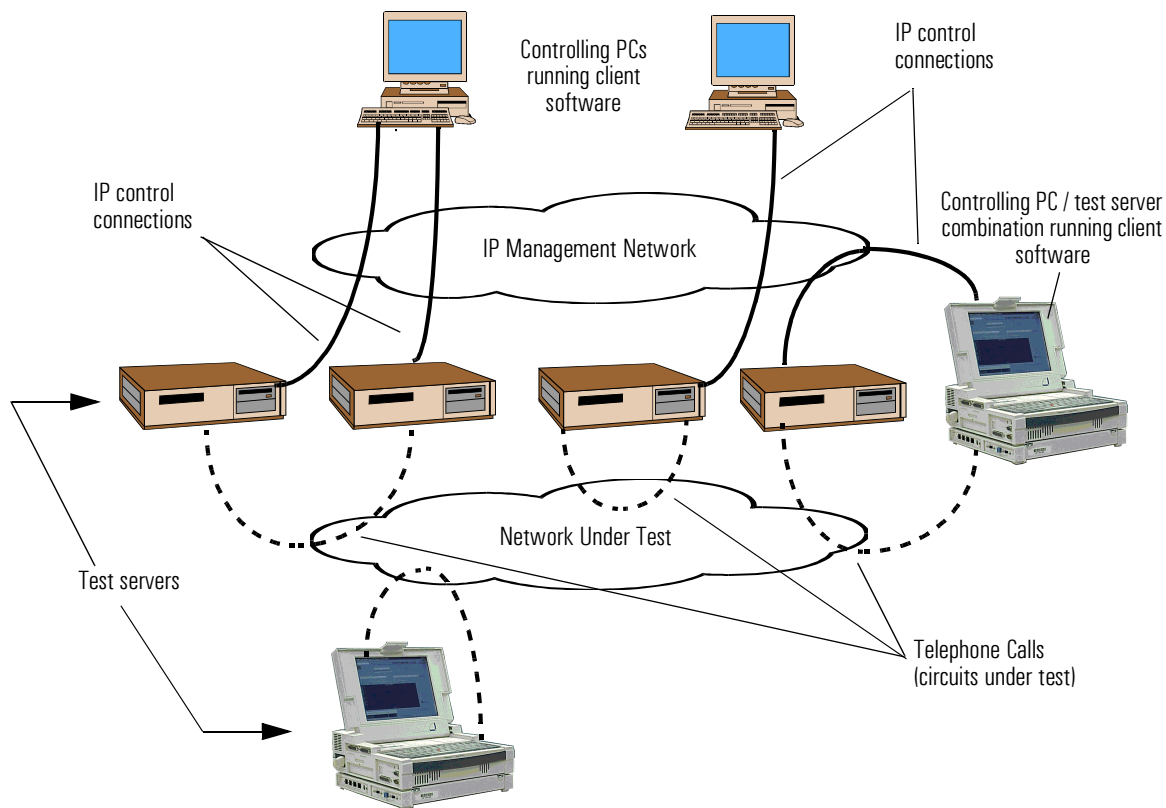

As shown above, the VQT system consists of “controlling PCs” (running “client” software) that operate “test servers”. The controlling PC and the test server can be the same device, and the test server can be one of several Agilent VQT devices including the VQT Portable Analyzer.

The controlling PC communicates with one or more test servers via an IP management network. Voice quality tests are run between ports or channels on the test servers. As the diagram shows, there is a distinction between the IP management network and the network under test, although they could be the same network depending on how they are deployed.

VQT test equipment such as the VQT Portable Analyzer and the Agilent Advisor can be controlling PCs as can a desktop/laptop PC. The VQT Network Server cannot serve as a controlling PC. In addition, the VQT Portable Analyzer and the Agilent Advisor (with a VQT undercradle) can perform as test servers (i.e. be controlled by VQT software running on the controlling PC). The above architecture illustrates three basic modes of operation which are described in more detail next.

- **Locally Controlled, Single-Server Testing**  
Refers to the VQT Portable Analyzer or Agilent Advisor (with a VQT undercradle) operated from its keyboard and monitor. This common mode of operation (shown below) is often used when portable testing is required. This mode also offers the largest selection of voice quality measurements.

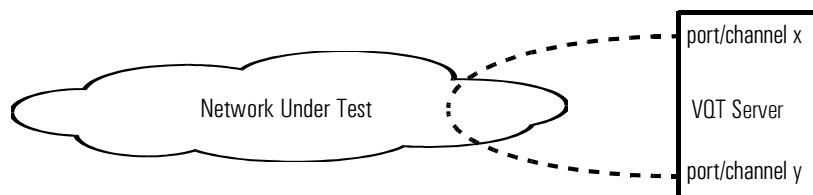

Introduction  
Overview of the Agilent VQT Test System

- Remotely Controlled, Single-Server Testing  
Refers to the case where a single VQT device is controlled by another PC to establish end-to-end connections for testing. The main difference between this mode and the one described previously is that the VQT server is being controlled via an IP connection by a PC running VQT software. Remember, this “controlling PC” can be another VQT Portable Analyzer, an Agilent Advisor, or a desktop/laptop PC.

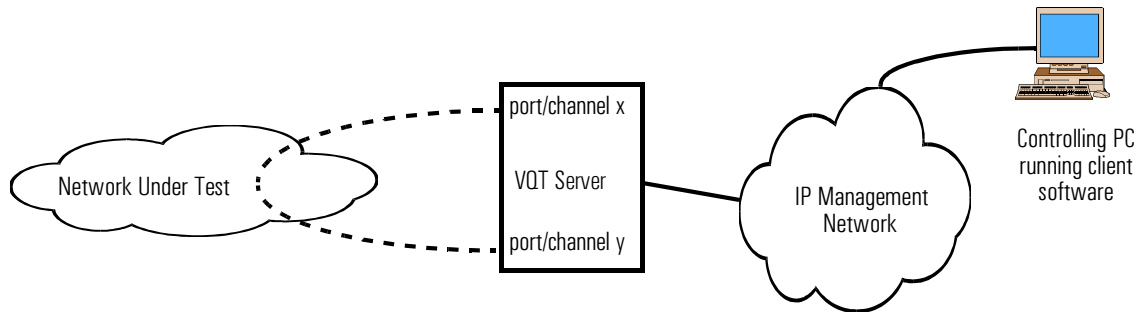

- Locally and/or Remotely Controlled, Multiple-Server Testing  
Refers to the case where two VQT devices place calls to each other to establish the circuit(s) under test. These calls are typically placed between ports/channels on one VQT and ports/channels on another, allowing end-to-end or round-trip measurements across voice circuits that terminate in different locations. Because VQT Portable Analyzers and Agilent Advisors can be run either as test servers or as controlling PCs (running VQT software), various configurations of local and remote control are possible (as shown below). This operational mode allows truly “distributed” measurements in which test signals are sent end-to-end for analysis.

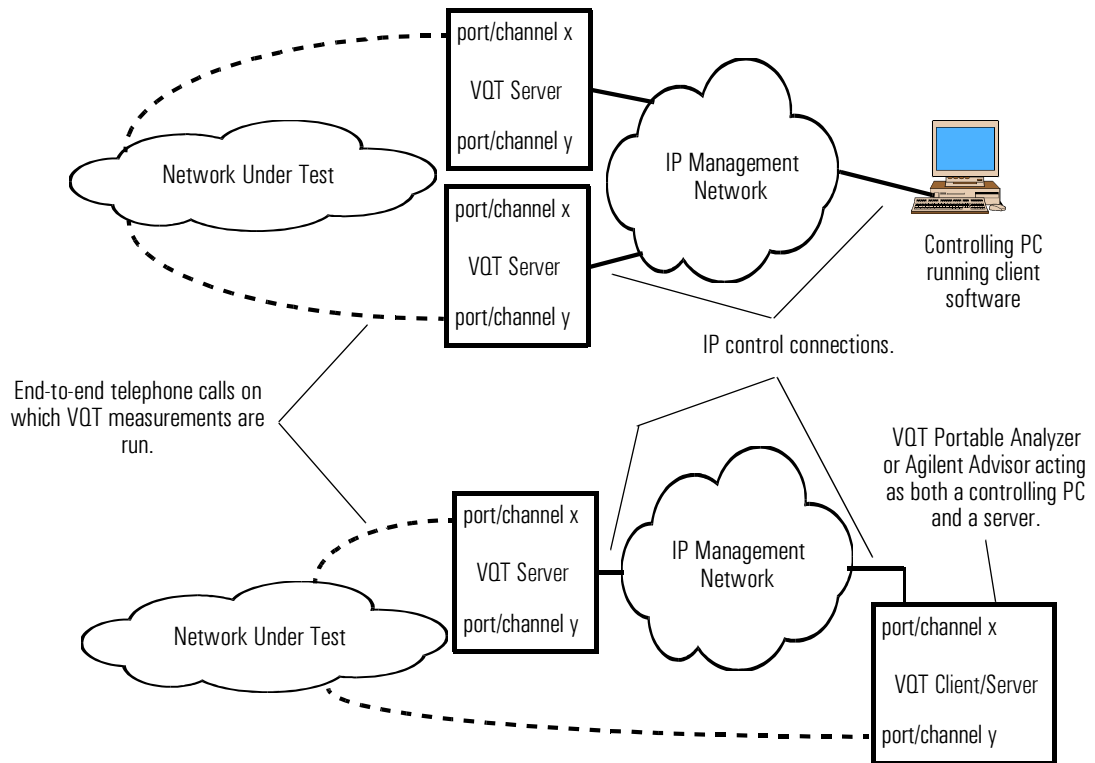

## Additional Notes on the Operational Modes

- VQT Portable Analyzers and Agilent Advisors can be used in the “local, single-server mode” by default. However, remote control of a VQT server requires a client license that is purchased separately.
- When controlling a VQT server from a PC, all interaction with the server is via the PC's user interface.
- Server software and VQT software cannot operate independently when running in a remote/distributed environment.
- Whether a VQT Portable Analyzer or an Agilent Advisor work as a controlling PC or as a dedicated server depends on configuration settings and a client license.
- Two controlling PCs cannot control a single server at the same time. However, a single controlling PC can have up to four client windows open and running simultaneously.
- A VQT Network Server cannot serve as a controlling PC.

---

## 2

- Setup Process Overview, page 2-3
- Planning VQT Testing Strategy, page 2-6
- Setting Up the Advisor and VQT Undercradle, page 2-7
- Configuring for Remote/Distributed Testing, page 2-9
- Connecting the VQT Undercradle, page 2-15
- Starting the VQT Application and Using the Server Setup Tool, page 2-23

---

## Getting Started

---

# Getting Started

This chapter describes how to setup and configure the Agilent Advisor and VQT Undercradle to perform voice quality measurements. Testing strategies are also described in this chapter to help you decide how and where to use the VQT Undercradle. Once you become more familiar with this powerful voice quality test tool, you can deviate from the procedures outlined here to suit your own test needs.

Please refer to the *Agilent VQT Getting Started Guide* or to the VQT's online Help for information on running voice quality measurements and interpreting their results.

---

**Note**

---

Some aspects of the Advisor's setup and configuration are not covered in detail in this Setup Guide. When necessary, please refer to the Agilent Advisor Mainframe Features Guide for specific information.



---

## Setup Process Overview

The Agilent Advisor with VQT Undercradle basic setup process is summarized in the next several pages. Each of the five basic steps shown here is described in more detail in the remaining pages of this chapter.

① Determine your network testing strategy.

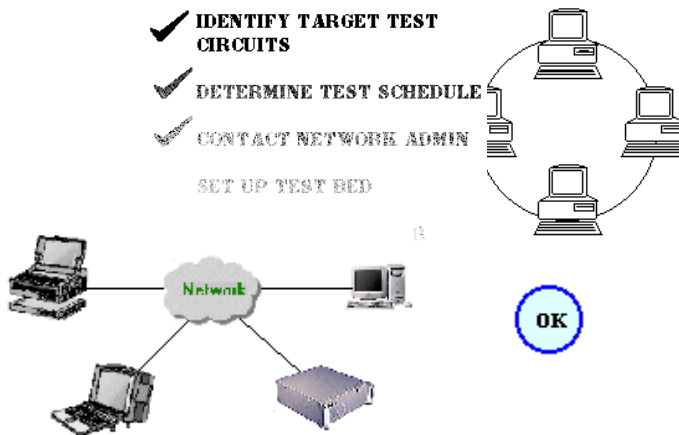

Getting Started  
Setup Process Overview

- ② Physically set up the Advisor and VQT Undercradle.

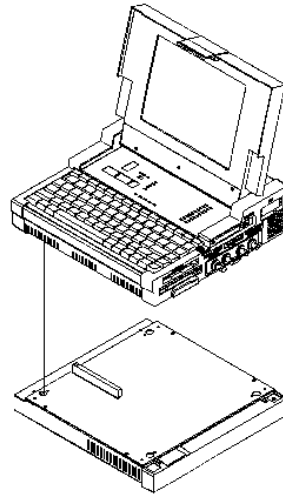

- ③ Configure the Advisor and Undercradle for remote/distributed testing (if necessary).

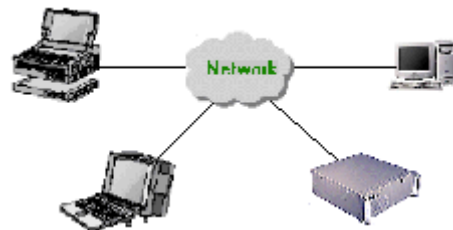
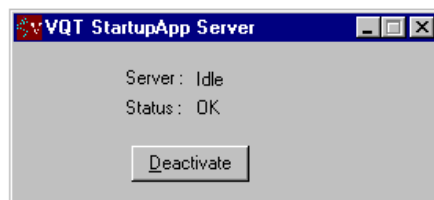
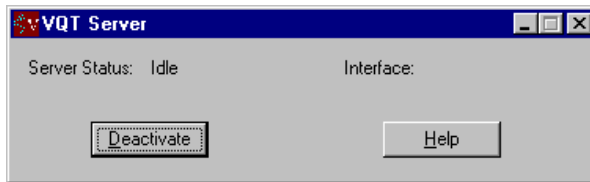

- ④ Connect the VQT Undercradle to the network/system under test.

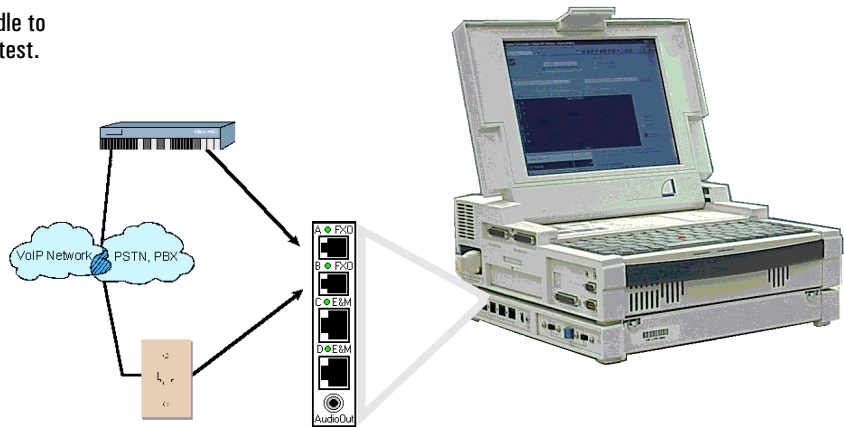

- ⑤ Start the VQT application on the controlling PC or Advisor.

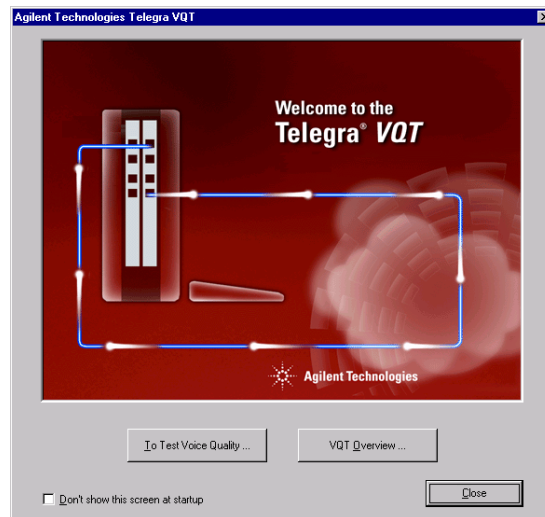

The remaining sections of this chapter describe each of the previous steps in detail.

## Planning VQT Testing Strategy

While you may have planned your testing as part of the purchasing process, it is a good idea to spend some time thinking about how to deploy your Advisor with VQT Undercradle. Consider the following:

- **Testing Roles of VQT Equipment**  
As discussed in Chapter 1, the Agilent Advisor (with VQT Undercradle) is often used as a standalone voice quality tester. It can also play the “client” or “server” role in a remote/distributed testing scenario. Existing networked computers can also play the “client” role if you plan to use desktop or laptop computers to control VQT equipment. The role each device will play determines how you set up your equipment (physical location and connections, software configuration, voice network management processes, etc.) both initially and later as testing needs and roles change.
- **IP Management Network vs. Network Under Test**  
Remember the distinction between the IP management network and the network/system under test. For remotely controlled VQT test equipment, or VQT equipment that will be used as “controlling PCs”, TCP/IP network connections need to be physically near the connections you make to the network under test. It is also possible that the management network and the network under test could be the same network. In addition, it may be necessary to work with network administrators when configuring and connecting VQT equipment to the IP network — You might need to obtain various permissions and IP addresses, and react to other network conditions.
- **Logistical Concerns**  
When performing remote/distributed testing, VQT devices will likely be installed in widely dispersed locations. Because of this, you need to coordinate the installation and configuration of each component. For existing VQT equipment, software (and perhaps hardware) upgrades might need to be performed. For all involved equipment, IP connectivity will need to be configured and arranged, and server security often need to be coordinated. Once the initial setup has been performed, IP and network under test connections need to be verified. Keep in mind, too, that subsequent changes to configurations and software may have to be done on location — This should be allowed for in your network test planning.

---

## Setting Up the Advisor and VQT Undercradle

This section describes how to set up your new Agilent Advisor and VQT Undercradle or how to upgrade your existing one for locally controlled, single server testing. If you plan to use the Advisor in a remote/distributed environment, please also read “Configuring for Remote/Distributed Testing” later in this chapter.

---

### Setting Up a New Advisor and VQT Undercradle

#### Setting Up the Advisor and Undercradle

If you purchased the Agilent Advisor with the VQT Undercradle, the Advisor is shipped with the VQT application software installed on the hard drive. Refer to “First-Time Startup for Agilent Advisor” later in this section.

If you previously purchased the Agilent Advisor and are now adding a VQT Undercradle to your system, refer to the instructions in the Software Installation Guide supplied with the Advisor software CD to install the application software. Then use the Mainframe Features Guide for instructions on how to connect the Undercradle to your Advisor. (Be sure the Internet Advisor power switch is set to Off before removing or installing Undercradles.) After the hardware installation is completed, refer to Starting the VQT Application section later in this chapter

The analog signal acquisition ports are located on the left side of the chassis.



Ground Connections

---

**Note**

The VQT's audio volume is controlled by adjusting the CD Audio level in the Windows Volume Control dialog box (double-click the 'speaker' icon in the status bar).

---

**First-time Startup for the Agilent Advisor and VQT Undercradle**

The first time you turn on the Advisor with the software shipped from Agilent Technologies, you are required to enter some basic information and configuration. Simply respond to the prompts as they are displayed. Note the following:

- When asked for your name and organization, type in the name of the primary user and the organization for which he/she works. Note, however, that this information is not used in later configuration or set up tasks - it is strictly for record keeping purposes.
- A Certificate of Authenticity box prompts you for an authenticity number. Enter the Microsoft Windows authenticity product ID# provided with the mainframe.

---

**Upgrading An Existing Advisor with VQT Undercradle**

Upgrading an existing Agilent Advisor for voice quality testing consists of installing the latest software and/or installing the VQT undercradle. In the case of the Advisor upgrade, you need to install the software prior to installing the undercradle.

- **Installing Software**  
Depending on when you purchase your VQT upgrade, VQT software can be installed either from the Agilent Advisor 11.9 (or higher) CD or the VQT 4.1 (or higher) CD]. Please refer to your Agilent Advisor installation instructions to install this software. Note: During the installation, you can select various options (see previous illustration). Make sure all options are selected. Later in the process, you will be required to enter your Client License Key to enable the VQT's remote / distributed capabilities if you intend to use your Advisor as a 'controlling PC'.
- **Installing Hardware**  
Please refer to your Agilent Advisor Mainframe Features Manual or the VQT Undercradle Getting Started Guide for instructions on installing an undercradle.

---

## Configuring for Remote/Distributed Testing

If you plan to control your Agilent Advisor from its own keyboard and monitor to perform “single-server” testing (see chapter 1 for more information), you can proceed on to the “Connecting the VQT Portable Analyzer” section for physical connection information. If, however, you plan to either use the Advisor as a “controlling PC” or remotely control it using another PC or other VQT device, you need to configure the Advisor for IP network connectivity and for the role it will play. These configuration tasks are covered in this section.

---

**Note**

Before you set up the Advisor (or desktop/laptop PC) for IP management network connectivity, please contact your IP network administrator. You will need to have specific information (IP addresses, subnet masks, default gateways, etc.) that may be used during the configuration process.

---

---

## IP Network Configuration

The Agilent Advisor provides IP network connectivity through the use of its PCMCIA card slots. You will need to purchase a PCMCIA network interface card either from Agilent or from another NIC vendor.

If you purchased your Agilent Advisor with the NIC card already installed, Windows 98 will detect the NIC card drivers automatically. You may still need to configure Windows 98 networking.

If you purchased a NIC card from another vendor, please refer to the Installation Instructions and installation media supplied with the product.

## IP Network Physical Connection

Once you have configured the Advisor, you will need to connect it to the IP network. There are two types of IP/Ethernet physical connections that you can use if you plan to operate the Advisor in a remote/distributed environment:

- Connect the Advisor's NIC to an IP network LAN drop, hub, router, or switch using a 10/100 RJ-45 Ethernet cable. You may want to contact your network administrator prior to making this connection to ensure you have the appropriate permissions and LAN connections are enabled.
- Connect the Advisor's NIC to a VQT Network Server's NIC directly using a 10/100 RJ-45 Ethernet *cross-over* cable. This connection allows you to control a rackmountable Network Server directly (see Note below).

In either of the above cases, the IP connection must have the following characteristics:

10/100 Ethernet.

Uses a standard Windows TCP/IP protocol stack.

You will have to configure the controlling PC (including the Advisor if it plays this role) slightly differently depending on how you physically connect it. This is covered in the "Setting Up the Controlling PC" section later in this chapter.

---

## Configuring the Portable Analyzer as a Server

If you intend to install the Agilent Advisor with VQT Undercradle in a network POP (points of presence), remotely located test bed or lab, or at a customer site to be remotely controlled as a dedicated server, you will need to configure it accordingly.

Configuring VQT equipment for this type of operation consists of starting "VQT server processes" that will respond to controlling PC commands when those commands are received.

To start VQT server processes on the Agilent Advisor, simply double-click the Startup VQT Servers icon in the Windows 98 desktop. The two dialog boxes shown in the following illustration will be displayed.



Shows whether a user is connected to the server. In this illustration, a user is not connected.

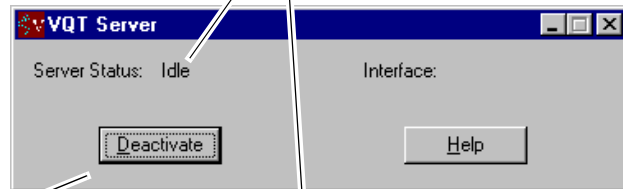

You can close server processes by clicking these buttons

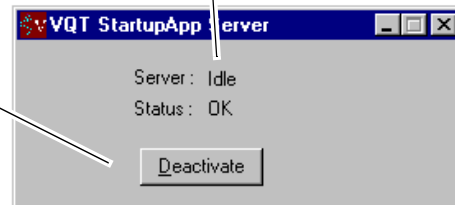

To stop these processes, click the Deactivate button in each of the two small dialog boxes.

---

**Note**

The Windows 98 operating system on the Advisor does not support automatic server processes startup.

---

## Setting Up the Controlling PC (Agilent Advisor)

You can use a desktop/laptop PC or an Agilent Advisor to remotely control the VQT Network Server, another Agilent Advisor (with VQT Undercradle), or a VQT Portable Analyzer. Typically, you control these devices across an IP network. This section describes how to set up the controlling PC whether it is a VQT device or your own PC.

To set up a controlling PC, you need to install the VQT application, enter your Client License Key, and verify that the PC is installed on the IP management network. Each of these steps are described on the following pages.

Your computer (if it is not an Agilent Advisor) needs to meet the following requirements to be used as a VQT controlling PC:

### Minimum Requirements for Controlling PC

Operating System: Windows 98 SE, Windows NT 4.0 SP5, Windows 2000  
CPU: Pentium III, 200 MHz  
Memory: 64 Mbytes  
Hard Disk Drive: 100 Mbytes available  
Screen Resolution: 800x600  
Microsoft's TCP/IP stack  
Microsoft Internet Explorer 4.0 (or higher)

### Recommended Configuration

Operating System: Windows 98 SE, Windows NT 4.0 SP5, Windows 2000  
CPU: Pentium III, 500 MHz  
Memory: 128 Mbytes  
Hard Disk Drive: 100 Mbytes available  
Screen Resolution: 1024x768  
Microsoft's TCP/IP stack  
Microsoft Internet Explorer 4.0 (or higher)

- Install the VQT software  
To install the VQT application on the controlling PC:
  - (1) Place the VQT 4.1 or higher CD into the your CD ROM drive.
  - (2) Click the Start button in the Windows desktop, and then click the Run button.
  - (3) Type `d:\setup.exe` and click OK.

During the installation, you can select various options (see the following illustration). Make sure all options are selected except the VQT server option.

---

**Note**

---

If you are using an Agilent Advisor as a controlling PC, a previous section of this chapter already described how to install the software. However, please note the applicable configuration information presented next.

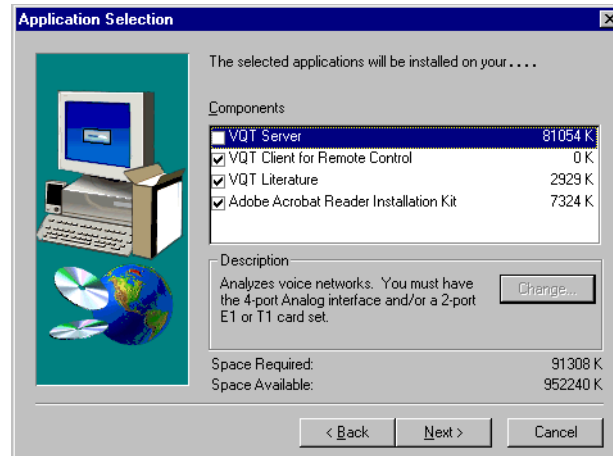

- Enter the Client License Key  
After you start the VQT software, you will need to enter your Client License Key. The license key is included in your VQT literature pack and can be entered using a File menu option once you start the VQT software.
- Enter additional Client License Keys  
If you are going to use more than one controlling PC, you will need to enter an additional Client License Key for each additional controlling PC. The license key is included in your VQT literature pack.
- Configure the PC for IP Network Connectivity  
Contact your network administrator to make sure your PC is connected to the IP management network and running a TCP/IP protocol stack. It is beyond the scope of this Setup Guide to provide comprehensive instructions on how to enable and connect your desktop or laptop PC for IP network connectivity. Contact your network administrator if your PC is not already networked.

**Getting Started**  
**Configuring for Remote/Distributed Testing**

- **Configuring the PC If Directly Connected to the Network Server**  
When you connect the controlling PC directly to the Network Server using an Ethernet cross-over cable, communication between the two devices is not arbitrated by a domain name server (normally present on an IP network). To deal with this problem, you will have to edit (or create) a file on the controlling PC. To do this:  
(1) Search for a “hosts” file (no extension) on the controlling PC. If there is one, you have completed this procedure and you can run the VQT application. Otherwise...  
(2) Find the hosts.sam file (.sam extension) on the controlling PC and make a copy of it to the same directory using the file name “hosts” (no extension). Edit the new “hosts” file in a text editor to update the IP and default router addresses to exactly match those used for the new VQT Network Server.

You should now be able to start the VQT application and control appropriately connected VQT test equipment.

---

## Connecting the VQT Undercradle

Connecting the VQT to the device, system, or network to be tested is relatively simple once you remember the VQT's basic test assumption: Voice quality is tested end-to-end from the perspective of the human talker and listener. In most cases, VQT servers replace telephone equipment at each end of the connection so that you can place a call or calls from a VQT port or channel through a telephony network (VoIP, PSTN, and so on) to another VQT port or channel.

This section includes the following connection information:

- FXO and E&M Connections, page 2-16
- Ground Connections, page 2-19
- Test Environment Examples, page 2-22

All of the VQT Undercradle's connections are made on its side panel.

### FXO and E&M Connections

The following diagrams illustrate how the VQT plays the role of two telephones in an end-to-end test environment for an analog (FXO/E&M) connection. While this diagram shows telephony end points being replaced by ports on a single VQT server, these end points could also be individual Agilent Advisors, VQT Network Servers, or VQT Portable Analyzers.

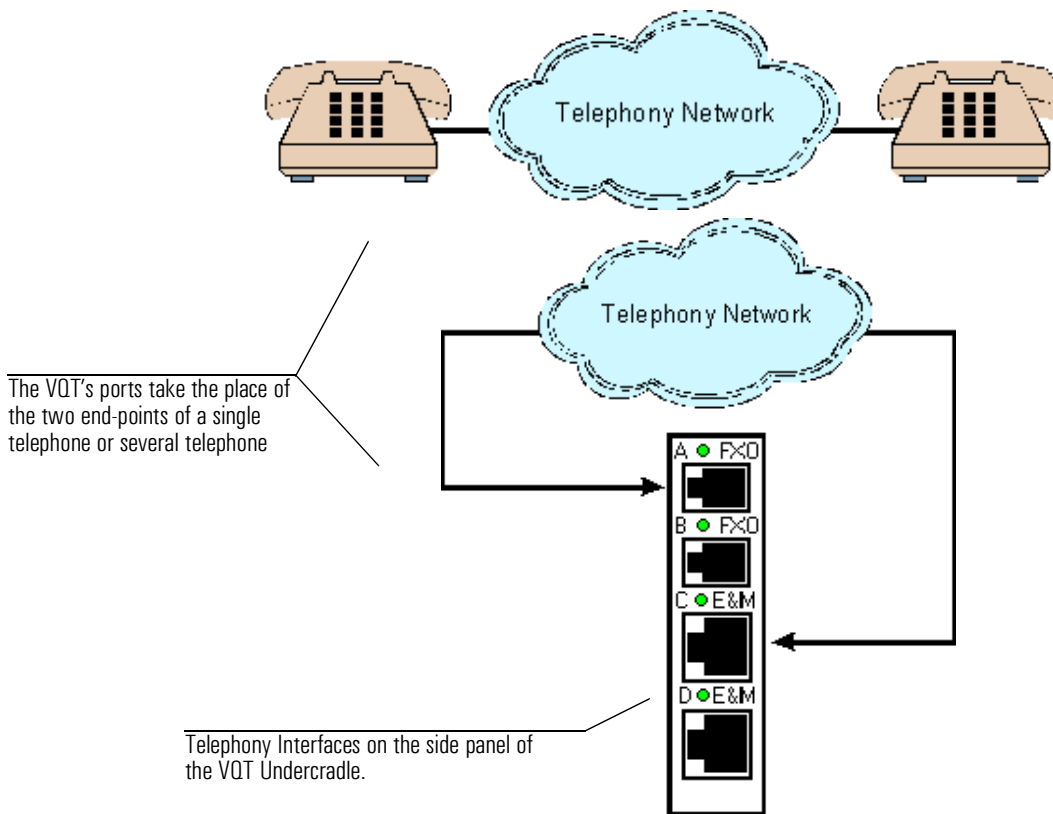

---

**Note** This equipment must not be connected to the telephone network unless it is connected through protective circuitry that is registered pursuant to Part 68 of the Federal Communications Commission rules.

---

### FXO Connection Diagram

The diagram below shows an end-to-end connection between FXO ports A / B of the VQT Undercradle and telephony/network device(s) that support the FXS interface. You need to use one custom Agilent Technologies RJ-11 cable to ensure the VQT communicates properly with the telephone network. You can use an additional “off-the-shelf” RJ-11 cable and coupler to extend the cable length for “Loop Start” operation. However, because of the way off-the-shelf cables can be wired, you must use one and only one Agilent custom RJ-11 cable for each port connection for “Ground Start” operation. See the VQT software’s Help for FXO wiring and pinouts and for more information about FXO connections in general.

The VQT Undercradle provides for end-to-end testing regardless of the port used. In other words, you can place calls from an FXO port to an E&M port if the situation requires it.

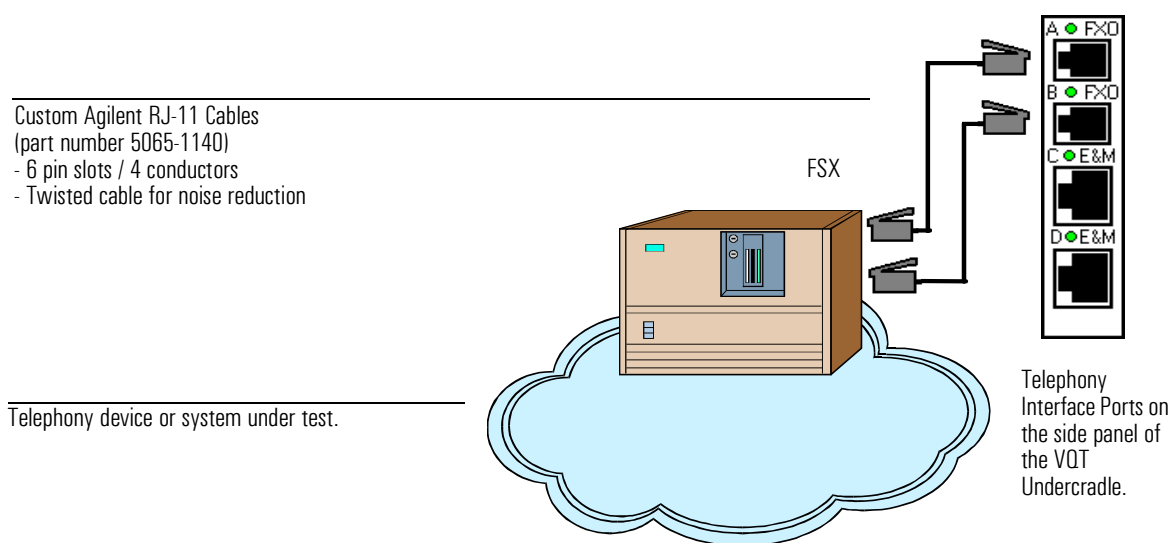

#### Note

For FXO/E&M interfaces, the electrical state of the VQT’s ports affect telephony network operation. Therefore, it is a good idea to know the electrical and protocol characteristics of the network you connect to, and make sure the Port Setup parameters match these characteristics.

**Getting Started**  
**Connecting the VQT Undercradle**

E&M Connection Diagram

E&M connections can be as simple as plugging the RJ-45 connector into the E&M port on the device/system under test, or as complex as connecting individual wires to punch-down blocks. The illustration below shows a common end-to-end E&M connection. Depending on the standards document to which you refer, there are several terms that can be used to describe the side of the E&M link to which the VQT Undercradle is connected. As shown, the VQT Undercradle is thought of as being on the “PBX”, “Trunk Circuit”, or “Customer Installation” side of the link. See the VQT software’s Help for descriptions of pinouts and wiring for Agilent's E&M cables and connectors.

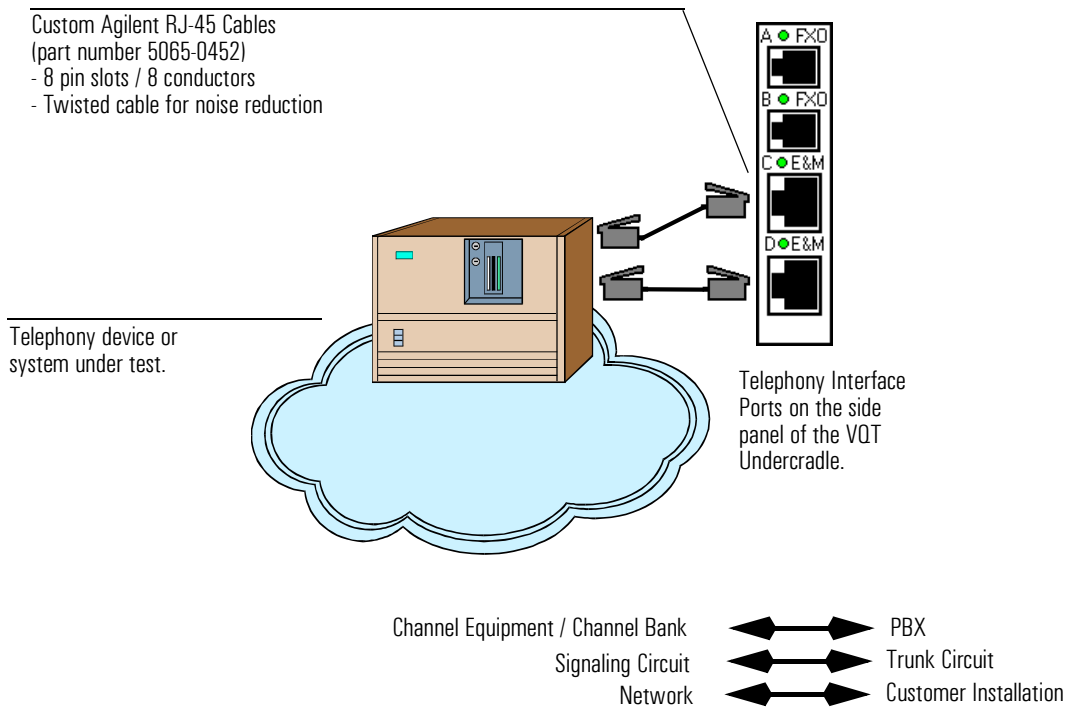

**Note** For FXO/E&M interfaces, the electrical state of the VQT’s ports affect telephony network operation. Therefore, it is a good idea to know the electrical and protocol characteristics of the network you connect to, and make sure the Port Setup parameters match these characteristics.



## Ground Connections

The VQT Undercradle is equipped with several electrical grounding options that increase the reliability of its operation and ensure compliance with domestic and international telecommunication and safety standards. Refer to the procedures on the following pages to utilize these grounding options via the switch and terminal block faceplate on the side of the VQT Undercradle.

Switch 1	Switch 2	Function
LEFT	LEFT	Earth Ground: The VQT Undercradle is Telecommunications Network Voltage (TNV) grounded via the terminal block connector. Attach one end of the ground cable (Part number J3953-61604) to the terminal block and the other end to a reliable earth ground.
LEFT	RIGHT	Chassis Ground: The VQT Undercradle is TNV grounded via the ground wire in the power cable (no extra cable connection is needed).
RIGHT	LEFT	TNV Ground (Internally isolated).
RIGHT	RIGHT	TNV Ground (Internally isolated).

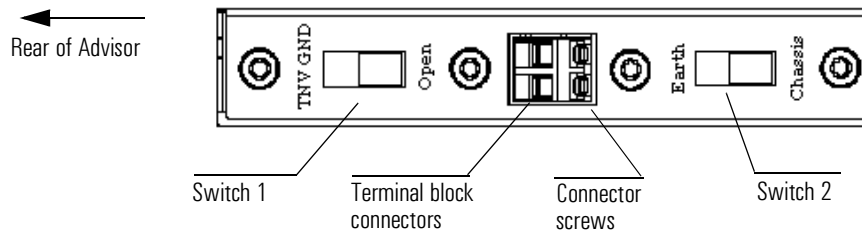

**Note** Port Setup configuration and ground configurations are related. See the online Help for more information. Grounding is required only in analog test situations.

**Getting Started**  
**Connecting the VQT Undercradle**

To ground the VQT Undercradle to “true earth ground”, perform the following:

- 1 Attach the supplied cable (J3953-61604) to one of the terminal block connectors.
- 2 Tighten the connector screw to hold it in place.
- 3 Connect the other end of the cable to “earth ground” (usually provided by a metallic rod or pipe driven into the earth.)
- 4 Set the switches as shown in the table above.

To ground the VQT Undercradle via the ground wire in the power cable (Chassis Ground), set the switches as shown in the table above. The VQT is shipped with this configuration as the default connection because, in most cases, the “Chassis Ground” provides adequate grounding and reliable operation.

As mentioned previously, in most test situations, the “chassis ground” setting is adequate. In some situations, such as Scandinavian countries that use IT power systems or if equipment is a large distance from the grounding source, the “Earth Ground” setting is required. “TNV Ground” (internally isolated) should be used for FXO loop start operations. It is possible for the equipment to be functional under a specific configuration, but not conform to safety standards.

Refer to the table below to determine the correct switch settings for your situation.

<b>Switch Modes</b>	<b>FXO Loop Start Only</b>	<b>FXO Ground Start Only</b>	<b>E&amp;M Only</b>	<b>FXO Loop Start /FXO Ground Start</b>	<b>FXO Loop Start/E&amp;M</b>	<b>FXO Ground Start/E&amp;M</b>
Earth Ground	Functional: Yes Safety: No	F: Yes S: Yes	F: Yes S: Yes	F: Yes S: Yes	F: Yes S: Yes	F: Yes S: Yes
Chassis Ground	Functional: Yes Safety: No	F: Depends on ground quality S: Not all countries	F: Depends on ground quality S: Not all countries	F: Depends on ground quality S: Not all countries	F: Depends on ground quality S: Not all countries	F: Depends on ground quality S: Not all countries
TNV Ground (Internally isolated)	Functional: Yes Safety: Yes	F: No	F: No	F: No	F: No	F: No

---

**Note**

The Chassis Ground switch mode might be too noisy and a differential voltage from “Earth Ground” might interfere with the test signal. To alleviate this condition run a wire to “Earth Ground”.

---

### Test Environment Examples

The VQT can be used in a wide range of test situations. Two examples of the system under test are shown below. Refer to the VQT Help for more examples.

#### Single Device Testing

Call is placed from one VQT port to another through a single telephony device. This connection scenario is used to test the performance of the device in isolation (i.e. no effects from traffic load, system noise, etc.). Often, several devices are linked together via an "ideal" network to test interoperability.

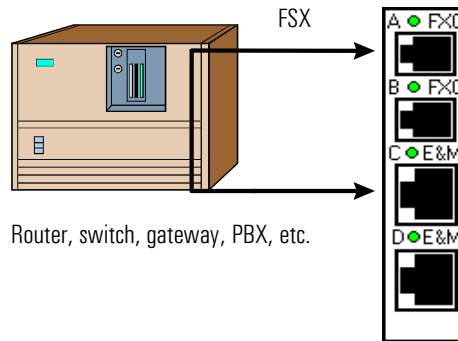

#### Integrated VoIP/PSTN Testing

Call is placed from one VQT port to the other through an integrated system. This could be an operational network or a test bed in a development lab. This connection scenario is often used to test multi-vendor interoperability, troubleshoot problems, and evaluate voice quality in a dynamic traffic load environment.

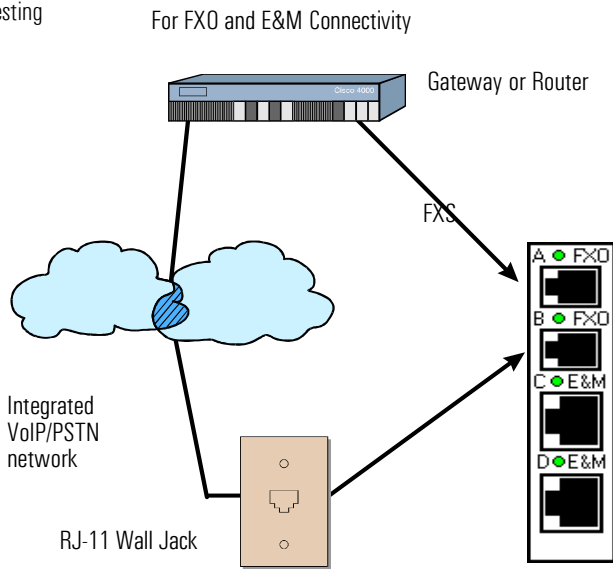

**Note**

The previous examples show a single VQT Undercradle controlling both ends of a telephone call. In a remote/distributed test environment, an individual VQT Undercradle (or VQT Network Server or Portable Analyzer) can control each end. Refer to the VQT's online Help for more information.

---

## Starting the VQT Application and Using the Server Setup Tool

After you have set up and configured the Agilent Advisor and VQT Undercradle (and the controlling PC if you are planning to remotely control the Advisor), you are ready to run VQT measurements using the VQT application. To start and run the VQT application:

- 1 Start the VQT application on the Advisor or controlling PC by clicking the VQT icon or Start menu option.



The Welcome window is displayed in which you can get more information about using the VQT application or about voice quality testing in general.

Once you are finished viewing this information, you can click the Close button to proceed.

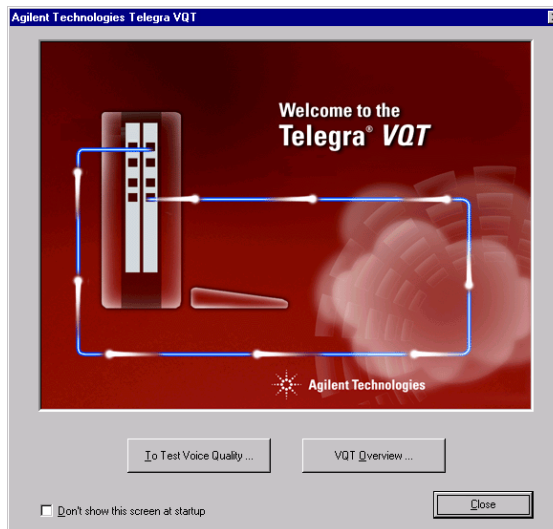

## Getting Started Starting the VQT Application and Using the Server Setup Tool

- ② After the Welcome window is closed, the first screen you see is the Server Setup tool.

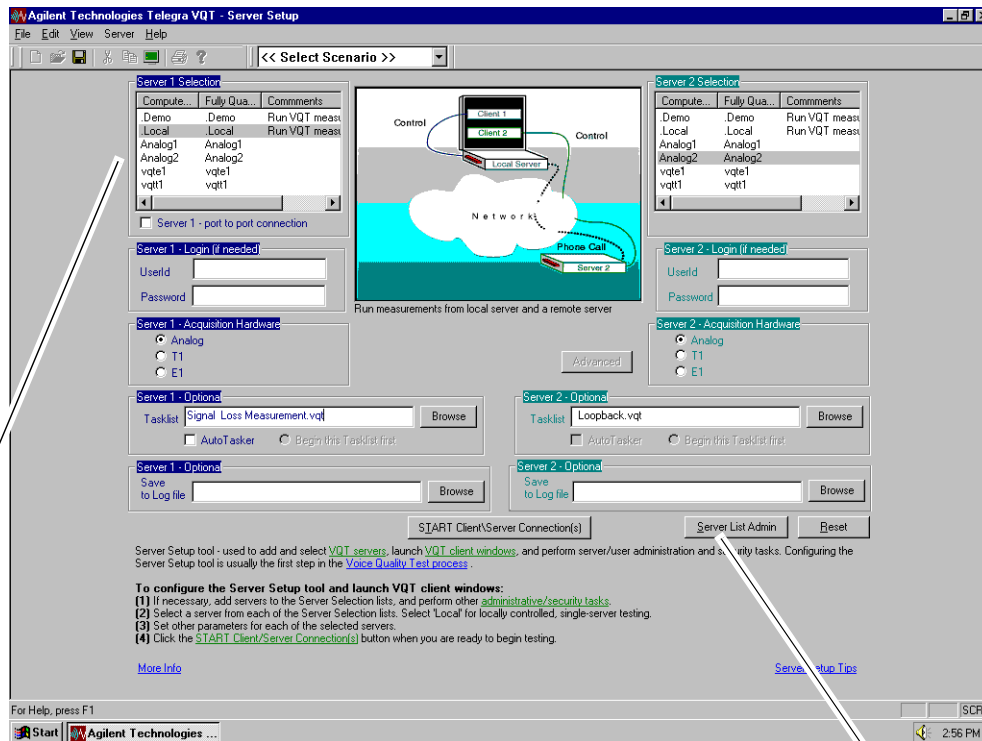

If you plan to perform locally controlled, single server testing, click "Local" in the Server Lists, click the Start Client/Server Connections button, and begin testing.

If you plan to perform remote/distributed testing, you need to add servers to the server list located at the top of the Server Setup tool. To do this, click the Server List Admin button. This opens the Server List dialog box shown on the next page.

To remotely control any VQT device, you will need to enter your client license key. To do this, use the File menu.

- ③ In the Server List dialog box, you build a list of servers (including the Advisor if you plan to remotely control it), and control server security and configuration.

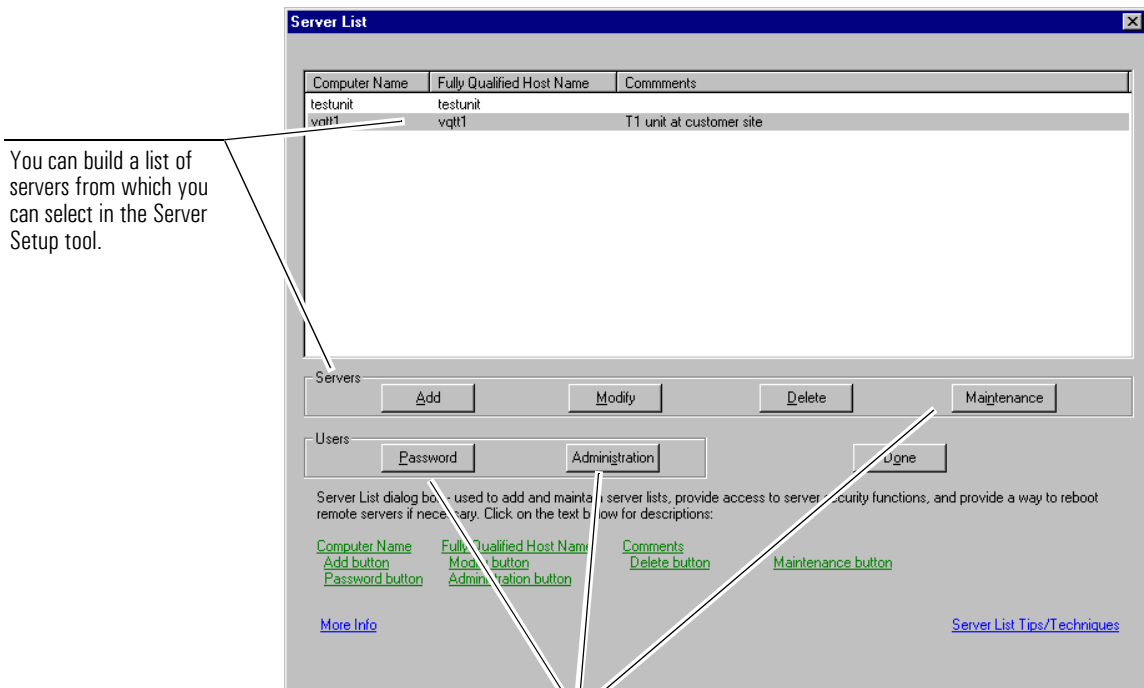

You can build a list of servers from which you can select in the Server Setup tool.

You can access the tools necessary to set up and maintain server security and other important remote control configuration settings.

Getting Started  
Starting the VQT Application and Using the Server Setup Tool

- ④ After you have closed the Server List dialog box, you can select the Advisor (locally or remotely) or other added servers and begin voice quality testing.

Select the newly added server(s) in the Server Lists.

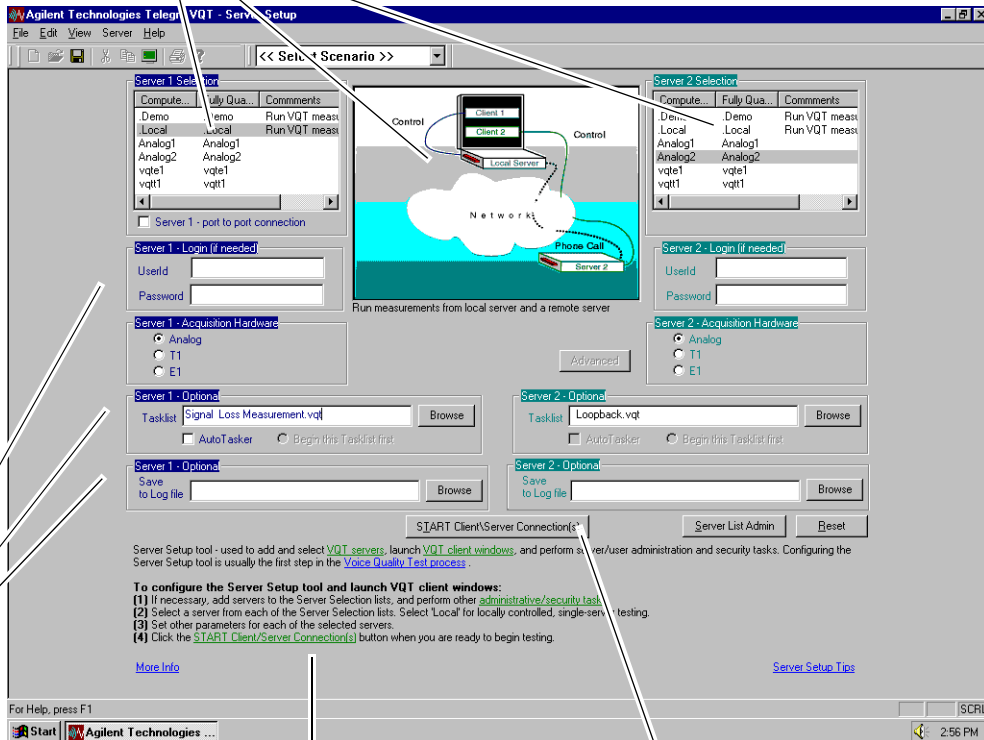

Choose the acquisition hardware to be used on the selected servers. You can also select the TaskLists and log files to use once client windows are opened.

Multi-mode embedded Help leads you through setup tasks.

Click the Start Client/Server Connection button to open client windows and begin testing.

**Note**

This Setup Guide focused on setup, configuration, and network connection for the VQT Portable Analyzer. Refer to the *Agilent VQT Getting Started Guide* or to Help for more information on using the VQT application.



---

**A**

---

**Specifications/Operating Conditions**

---

# Specifications/Operating Conditions

---

---

## FXO/E&M Card Specifications

### **FXO Ports**

Guaranteed accuracy of transmission or reception of a sine wave is plus or minus 1 dBm across the following conditions:

300 Hz to 3200 Hz

-3 dBm to -50 dBm

USA 600 ohms impedance, USA 900 ohms impedance.

Typical accuracy is plus or minus 0.3 dBm from 500 Hz to 3000 Hz.

### **E&M Ports**

Guaranteed accuracy of transmission or reception of a sine wave is plus or minus 1 dBm across the following conditions:

300 Hz to 3200 Hz

-3 dBm to -45 dBm

Standard 600 ohms impedance, Standard 900 ohms impedance.

Typical accuracy is plus or minus 0.3 dBm from 500 Hz to 3000 Hz.

### **FCC Part 68 Disclaimer**

This equipment must not be connected to the telephone network unless it is connected through protective circuitry that is registered pursuant to Part 68 of the Federal Communications Commission rules.

---

## Operating Conditions

<b>Temperature</b>	Operating	+5°C to +40°C (+41°F to +104°F)
	Non-operating	-25°C to +60°C (-13°F to +140°F)
<b>Humidity</b>	Operating	20% to 80% relative humidity, non-condensing
	Non-Operating	5% to 90% relative humidity, < 40°C, non-condensing 5% to 80% relative humidity, > 40°C, non-condensing
<b>Altitude</b>	Operating	4570 meters (15,000 feet)
	Non-Operating	12,200 meters (40,000 ft)
<b>Power Requirements</b>	External:	115/230 V~, 50-60 Hz, 4/2 A

Specifications/Operating Conditions  
**Operating Conditions**

---

**B**

---

Declaration of Conformity

---

# Declaration of Conformity

<b>DECLARATION OF CONFORMITY</b> <small>According to ISO/IEC Guide 22 and CEN/CENELEC EN 45014</small>	
<b>Manufacturer's Name:</b>	Agilent Technologies, Inc.
<b>Manufacturer's Address:</b>	Network Systems Test Division (NSTD) Colorado Springs, CO 80919-2497 USA
Declares that the product:	
<b>Product Name:</b>	VQT undercradle for Agilent Advisor
<b>Model Number:</b>	J4630A
<b>Product Options:</b>	This declaration covers all options of the above product.
Conforms to the following product standards:	
EMC:	
<u>Standard</u>	<u>Limit</u>
CISPR 11:1990 / EN 55011-1991	Group 1, Class A
EN 50082-1:1992	
IEC 801-2:1991	4 kV CD, 8 kV AD
IEC 801-3:1984	3 V/m, 80 - 1000 MHz
IEC 801-4:1988	0.5 kV sig. lines, 1 kV power lines
Safety: IEC 1010-1:1990 + A1 + A2 / EN 61010:1993	
<b>Conformity / Supplementary Information:</b>	
The product herewith complies with the requirements of the Low Voltage Directive 73/23/EEC and the EMC Directive 89/336/EEC and carries the CE-marking accordingly.	
Colorado Springs, CO, USA	15 September, 2000
	 Hamish Gray, Quality Manager

---

**C**

---

**Software Recovery**

---

# Software Recovery

In some cases, it may be necessary to re-install the application onto the Agilent Advisor. For example, if important system files have been accidentally deleted or have become corrupted, the VQT Undercradle will not operate correctly and the only solution is to re-install the software. Make sure to use Agilent Advisor software, Version 11.5 or higher.

This appendix provides installation and configuration instructions to recover the VQT application. Please call your technical support representative if you have problems with this process.

## **Re-install the Application**

- 1 Attach a CD-ROM drive to the Agilent Advisor.
- 2 Insert the Application CD into the CD-ROM drive.
- 3 Click the Start button in the Windows desktop, and select Run.
- 4 In the Open box, type: `D:\setup.exe` and click the OK button. The drive letter may be something other than 'D'. Use Windows Explorer to determine the drive letter if necessary.
- 5 It is recommended that you accept all defaults in the dialogs that are displayed during the installation process.
- 6 When the installation process is complete, remove the CD from the drive and restart the computer.



---

# Index

10/100 Ethernet, 2-10

## A

acquisition hardware, 1-5, 1-7

FXO, 1-5

administrator, 2-9

Advisor

setting up, 2-7

upgrading, 2-8

Agilent Advisor, 1-7

as a server, 2-10

as controlling PC, 2-12

IP connectivity, 2-9

setting up, 2-7

upgrading, 2-8

Agilent VQT

How Does It Work?, 1-8

Overview of System, 1-7

software, 1-6

analog connections, 2-16

application, 1-6, 1-8

client, 1-10

architecture, 1-10

audio volume, 2-8, 2-19

## C

client, 1-10, 2-6

client license key, 1-14, 2-13

configuring IP connectivity, 2-9

connecting the VQT, 2-15

connections, 2-10, 2-16

E&M, 2-18

FXO/FXS, 2-17

ground, 1-6, 2-19

RJ-11, 2-17

RJ-45, 2-18

controlling PC, 1-10, 2-6, 2-12, 2-13

installing VQT software, 2-12

CPU, 2-12

## D

diagrams, 2-15

Distributed Testing, 2-12

Distributed Voice Quality Testing

VQT architecture, 1-10

VQT modes of operation, 1-11

DSP card, 1-5

## E

E&M, 1-5, 1-9, 2-16, 2-18

E1, 1-7

Ethernet, 2-10

examples

integrated VoIP/PSTN testing, 2-22

single device testing, 2-22

## F

FCC Part 68, A-3

finding more information, 1-4

FXO, 1-5, 1-9, 2-16, 2-17

FXO/E&M, 1-7

## G

getting more information, 1-4

Getting Started, 2-2, 2-3

ground connections, 1-6, 2-19

## H

hardware, 1-7

Help, 1-4

How to...

configure for IP connectivity, 2-13

set up server processes, 2-10

## I

installing software, 2-12

installing the undercradle, 2-7

installing the VQT application, C-2

integrated VoIP/PSTN testing, 2-22

interface ports, 1-5

interfaces, 1-7

IP connectivity, 2-9

IP management network, 1-10, 2-6, 2-13

IP network connectivity, 2-10

## K

key, 1-14, 2-13

## L

license key, 1-14, 2-13

local operation, 1-11

## M

memory, 2-12

minimum PC requirements, 2-12

minimum requirements, 2-12

---

# Index

modes of operation, 1-11  
multi-server testing, 1-13

## N

network configuration setup, 2-9  
network interface card (NIC), 2-10  
Network Server, 1-4, 1-7  
NIC, 2-10

## O

online Help, 1-4  
operating conditions, A-3  
Overview  
    how the VQT works, 1-8  
    VQT system, 1-7

## P

PC  
    installing software, 2-12  
Plan Network Testing, 2-6  
platform, 1-5, 1-7  
Portable Analyzer, 1-4, 1-7  
portable test chassis, 1-5  
ports, 1-5

## R

remote control, 1-12  
Remote/Distributed Testing, 2-6, 2-12, 2-13  
    VQT architecture, 1-10  
    VQT modes of operation, 1-11  
requirements, 2-12  
RJ-11 connections, 2-17  
RJ-45, 2-10  
RJ-45 connections, 2-18

## S

screen resolution, 2-12  
security, 2-25  
server, 1-10, 2-6, 2-10, 2-13  
server processes, 2-10  
Server Setup tool, 2-24  
servers  
    adding, 2-24  
    security, 2-25  
server-to-server testing, 1-13  
setting up, 2-7, 2-12  
    network operation, 2-9  
single device testing, 2-22

single-server testing, 1-11, 1-12  
software, 1-8  
    client, 1-10  
    installing, 2-12  
    starting, 2-23  
    upgrading, 2-12  
software recovery, C-2  
start up, 2-8  
starting the application, 2-23  
system architecture, 1-10

## T

T1, 1-7  
TCP/IP stack, 2-10  
terminal block faceplate, 2-19  
testing  
    integrated VoIP/PSTN, 2-22  
    single device, 2-22  
testing strategy, 2-6

## U

Undercradle, 1-5  
    installing, 2-7  
undercradle, 1-7  
upgrading existing Advisor, 2-8

## V

volume control, 2-8, 2-19  
VQT  
    How Does It Work?, 1-8  
    modes of operation, 1-11  
    overview of system, 1-7  
    software, 1-6  
    system architecture, 1-10  
    test platform, 1-5  
    undercradle, 1-7  
VQT Network Server, 1-4, 1-7  
VQT Portable Analyzer, 1-4, 1-7  
VQT server processes, 2-10  
VQT Undercradle  
    acquisition card and ports, 1-5  
    description, 1-5  
    setting up, 2-7  
VQT undercradle, 2-8

## W

wiring diagrams, 2-10, 2-15