



Advanced Test Equipment Corp.
www.atecorp.com 800-404-ATEC (2832)

SL1700A Series Scienlab Battery Test System

Pack Level – Up to 300 kW¹

SL1710A

SL1720A

SL1730A

SL1740A



¹ Datasheet is valid for systems with a serial number equal or greater than DE61B50000 and for the systems with the serial numbers DE61B00179, DE61B00180, and DE61B00187

Systems With an Output Power Range of 100 kW up to 300 kW

Highly efficient test of high-power components on a small footprint.

The Keysight's Scienlab Battery Test System – Pack Level with the new silicon carbide technology is a highly efficient system based on state-of-the-art technology and allows to realistically emulate the environment of the future battery pack application in order to test the high-power battery pack comprehensively and improve its functions and safety.

The test system is supplied with the advanced test and control software Scienlab Energy Storage Discover (ESD). It helps the user to draw conclusions about durability, range and efficiency, the communication, functioning, heating of the pack, and the interaction with other components such as the SL1010A Scienlab BMS Environment (BMS).

The possible switching frequency of silicon carbide transistors is more than a factor of ten greater than the switching frequency of IGBTs. This results in a significantly higher efficiency and, conversely, a lower cooling power requirement and lower energy consumption. This space-saving technology without the need for large cooling systems enables systems with small installation space.

- Smaller footprint compared to systems with similar power
- 1.5 MW power due to parallelization
- Up to 1500 V DC for high-voltage batteries
- Based on new high-voltage silicon carbide (HV-SiC) technology
- Highly efficient with a recovery capability of up to 96%
- Reduced energy consumption and cooling water
- Pre-charge function ¹

¹ Functionality to set the output voltage to the voltage level of the battery before a test starts, even while the battery contactors are open (open circuit). By doing so, the battery recognizes a counter voltage and is able to close the contactors in order to start the actual test.

Specifications

In the following, a distinction is made in the technical data between specifications and supplemental characteristics. Unless otherwise noted, specifications are warranted over the ambient temperature range of 5 to 40 °C after a 30-minute warm-up period.

	SL1710A	SL1720A	SL1730A		SL1740A		
Power stages	1	1	2		3		
Power options	100 kW	100 kW	200 kW		300 kW		
Current options ¹	300 A	300 A	300 A	600 A	300 A	600 A	900 A
Voltage options ²	50 to 1000 V 50 to 1200 V 50 to 1500 V						
Voltage	1000 V		1200 V		1500 V		
Voltage accuracy ³	±0.03% of measured value, ±150 mV (offset)						
Current accuracy	300 A		600 A		900 A		
Current accuracy ³	±0.03% of measured value, ±150 mA (offset)						

¹ Parallel connection of several systems possible to achieve higher currents. If two or more systems are connected in parallel, all output stages are supplied equally regardless of the actual current class of the individual systems. In this case, the cross-sections of the DC cables must be designed accordingly. Test up to 1.62 MW (3600 A) packs with a parallel connection of up to six systems e.g., by connecting the individual DC cables to a remote power terminal (RPT) or a power switch terminal (PST).

² Additional voltage range of 20 to 300 V with option [SL17X0A-F02](#).

³ Measurement and programming accuracy; measurement with Number of Power-Line-Cycles (NPLC) = 100; valid for 1 year.

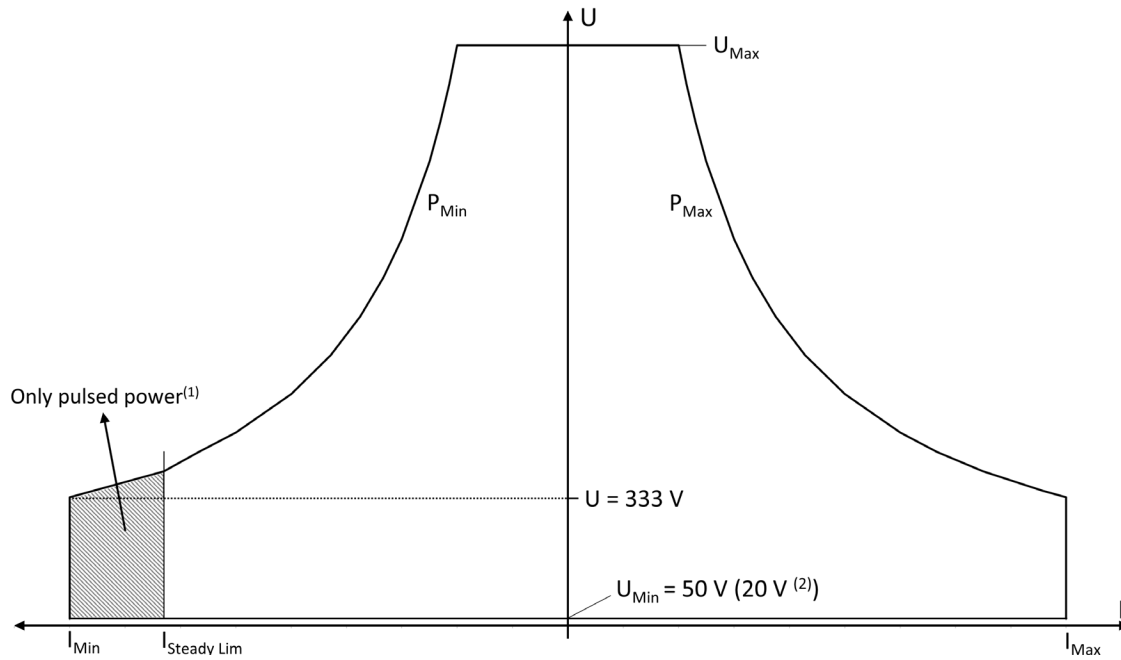

Figure 1. Output characteristics of the battery test systems.

All systems are power-limited and depending on the selected options the maximum voltage and current are varying. The limits are listed in Tables 1 and 2 below.

Table 1: Normal operation mode and limits

Systems	U_{Max}	I_{Max}	$I_{Steady Lim}$	I_{Min}	P_{Max}	P_{Min}
SL1710A	1000 V 1200 V 1500 V	300 A	-240 A	-300 A	100 kW	-100 kW
SL1720A		300 A	-240 A	-300 A	100 kW	-100 kW
SL1730A		300 A	-300 A	-300 A	200 kW	-200 kW
		600 A	-480 A	-600 A		
SL1740A		300 A	-300 A	-300 A	300 kW	-300 kW
	600 A 900 A	-600 A -720 A	-600 A -900 A			

¹ The area below the current limit $I_{Steady Lim}$ is only allowed to be used for a short amount of time. A recovery period is necessary before the system can be reused.

² Lower voltage limit is 50 V, Additional voltage range of 20 to 300 V with option [SL17X0A-F02](#).

Table 2: Pulsed power and allowed maximum durations

Voltage		20 V					
Current							
SL1710A/ SL1720A	-240 A	-250 A	-260 A	-270 A	-280 A	-290 A	-300 A
SL1730A	-480 A	-500 A	-520 A	-540 A	-560 A	-580 A	-600 A
SL1740A	-720 A	-750 A	-780 A	-810 A	-840 A	-870 A	-900 A
Max Duration¹	379 s	138 s	52 s	30 s	23 s	18 s	15 s

Voltage		330 V					
Current							
SL1710A/ SL1720A	-240 A	-250 A	-260 A	-270 A	-280 A	-290 A	-300 A
SL1730A	-480 A	-500 A	-520 A	-540 A	-560 A	-580 A	-600 A
SL1740A	-720 A	-750 A	-780 A	-810 A	-840 A	-870 A	-900 A
Max Duration¹	Unlimited	676 s	216 s	102 s	46 s	28 s	21 s

¹ Maximum allowed duration, after exceeding a recovery period of 20 s is required.

Supplemental Characteristics

Supplemental characteristics are not warranted but are descriptions of performance determined by design or type testing. Supplemental characteristics are typical unless otherwise noted and apply at the DUT in compliance with the specified load line length and the sense terminals connected to the output terminals (local sensing).

Voltage	1000 V	1200 V	1500 V
Typical accuracy ¹	<100 mV	<120 mV	<150 mV

Current	300 A	600 A	900 A
Typical accuracy ¹	<100 mA		
Ripple	<1.0 A _{eff}		
Rise and fall time ²	-300 → +300 A	-600 → +600 A	-900 → +900 A
	<1 ms @ 300 V DC measured from -90 → +90% ³		

Data acquisition

Resolution	Single-precision floating-point
Sample rate	Max. 1 kHz

¹ Typical accuracy under full scale.

² No switching times within power stage or channel at transition from positive to negative current and vice versa.

³ 2x 10 m load lines, 185 mm² cable-cross section.

System cabinet

	SL1710A	SL1720A	SL1730A	SL1740A
Weight	980 kg	1350 kg	1600 kg	1850 kg
Dimensions (H ¹ x W x D ²)	2.15 x 1.51 x 0.6 m	2.15 x 2.41 x 0.6 m		
Protection class	Class I, IP 54			
Heat dissipation	Max. 1 kW			
Ambient temperature	5 to 40 °C			
Relative humidity	max. 80 % (non-condensing) for temperatures up to 31 °C decreasing linearly to 50 % (non-condensing) at 40 °C			
Cabinet color	RAL 7035			

Note: A magnetic signal lamp with a height of 40 cm can be mounted variably at the cabinet and therefore does not necessarily have an influence on the system height.

Safety features

- Power contactors on the mains side ensure voltage-free operation
- Output contactors capable of disconnecting at full load current
- Emergency stop push button with redundant emergency stop chain
- Discharge of all internal high-voltage sources with regard to service
- Integration into Test Bench Software (ESD) and Test Bench Guard (TBG)
- Insulation resistance: $\geq 30 \text{ M}\Omega$
- Inherent safety against overheating, overpower, short-circuit
- Reverse polarity protection
- Signal light with magnetic mounting
 - Red: Error; Yellow: Active, Green: Ready

¹ Rollers increase the height by 4 cm.

² Depth incl. (emergency stop) push buttons

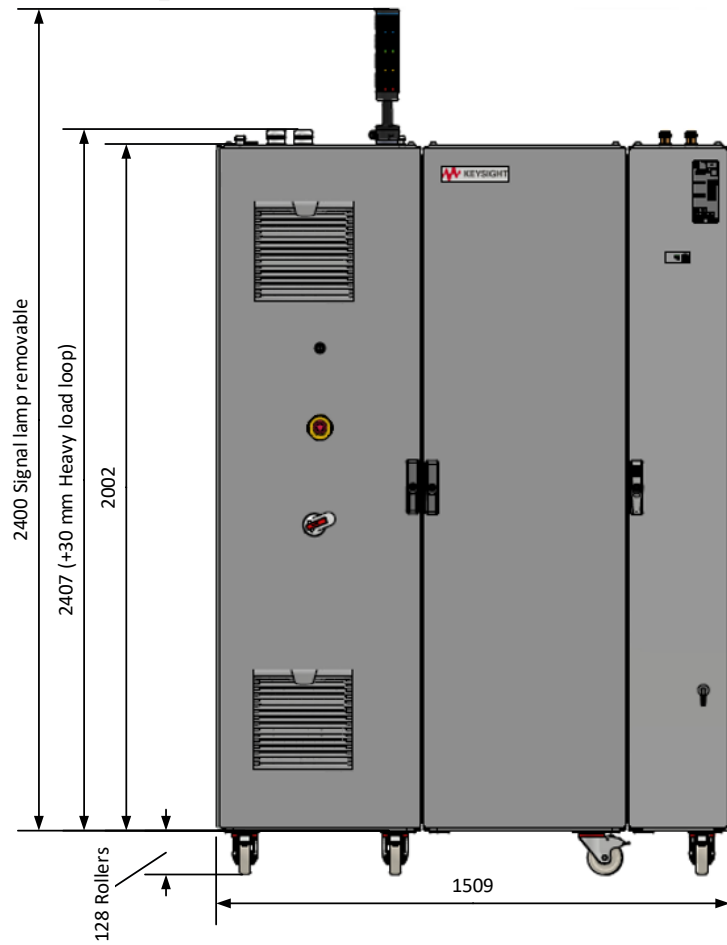

Figure 2. 100 kW System – front view incl. dimensions in mm.

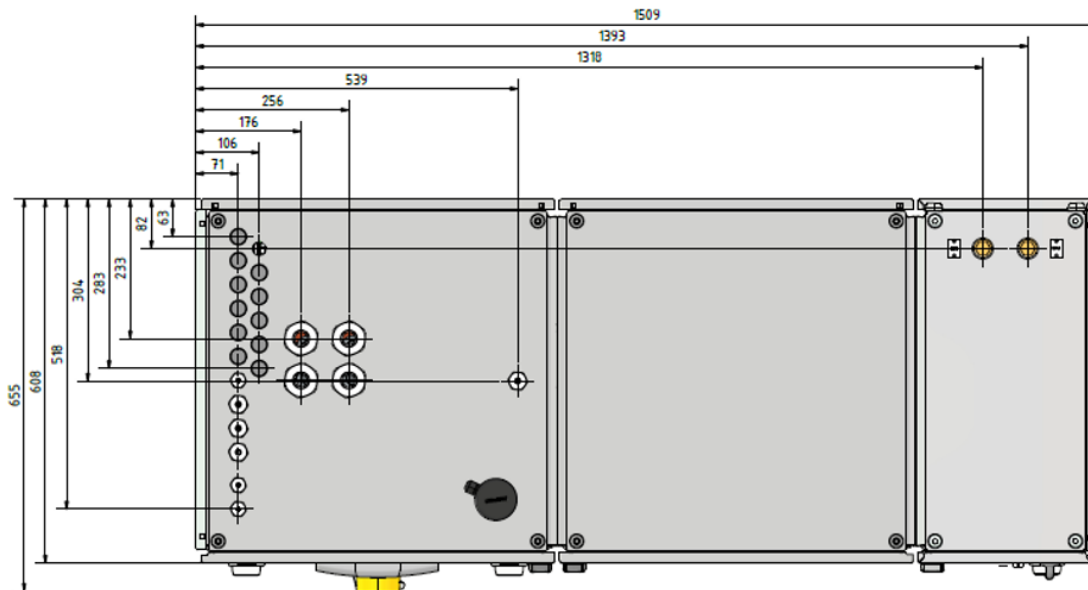

Figure 3. 100 kW System – top view incl. dimensions in mm.

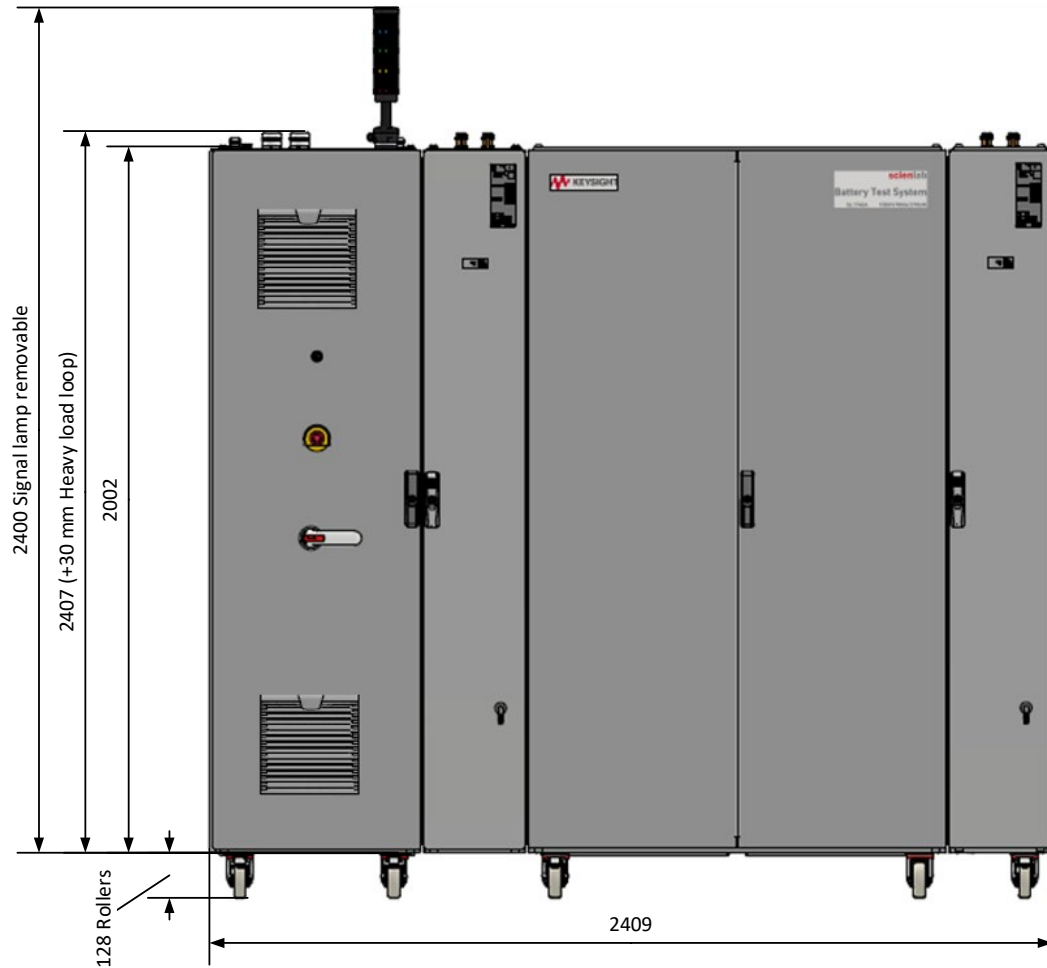

Figure 4. 300 kW System – front view incl. dimensions in mm.

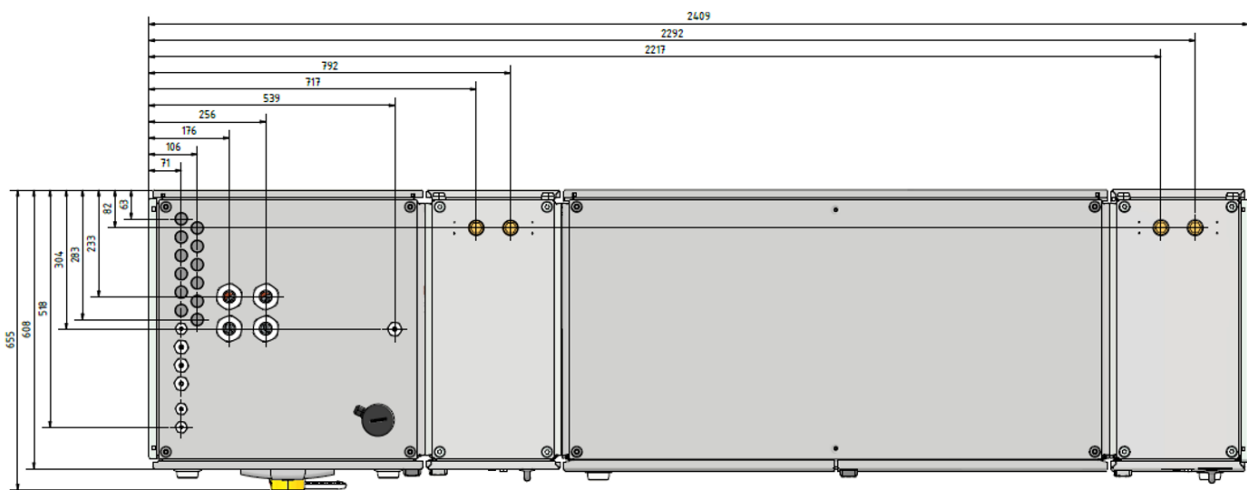

Figure 5. 300 kW System – top view incl. dimensions in mm.

System AC power and system cooling

System AC power

Efficiency	Up to 96%			
Mains supply	3 ~, Protective Earth, 380/400/440/480 V ($\pm 10\%$), 50/60 Hz			
Reactive power compensation	$\cos \phi > 0,99$ (under load) for $P > 0,5 * P_{max}$			
Input current In / Mains supply fuse provided on site¹	100 kW	200 kW	300 kW	
380 VAC	175 A / 200 A gG	340 A / 355 A gG	510 A / 630 A gG	
400 VAC	165 A / 200 A gG	325 A / 355 A gG	480 A / 500 A gG	
440 VAC	150 A / 160 A gG	300 A / 315 A gG	440 A / 500 A gG	
480 VAC	135 A / 160 A gG	270 A / 315 A gG	400 A / 400 A gG	
System cooling	SL1710A	SL1720A	SL1730A	SL1740A
Cooling type	Water/air heat exchanger			
Max. heat transfer @ ≥ 800 V	4 kW	4 kW	8 kW	12 kW
Cooling unit per system	1	2		
Cooling water temperature	Internal thread, inlet	$\frac{3}{4}$ ", 7 to 19 °C		
	Internal thread, outlet	$\frac{3}{4}$ ", max. 24 °C		
Max. flow rate per cooling unit	0.29 l/s	0.14 l/s	0.29 l/s	0.43 l/s
Inlet pressure	6 bar			
Pressure difference	>1 bar			

¹ Values recommendation for European Union (EU); consider country-specific standards.

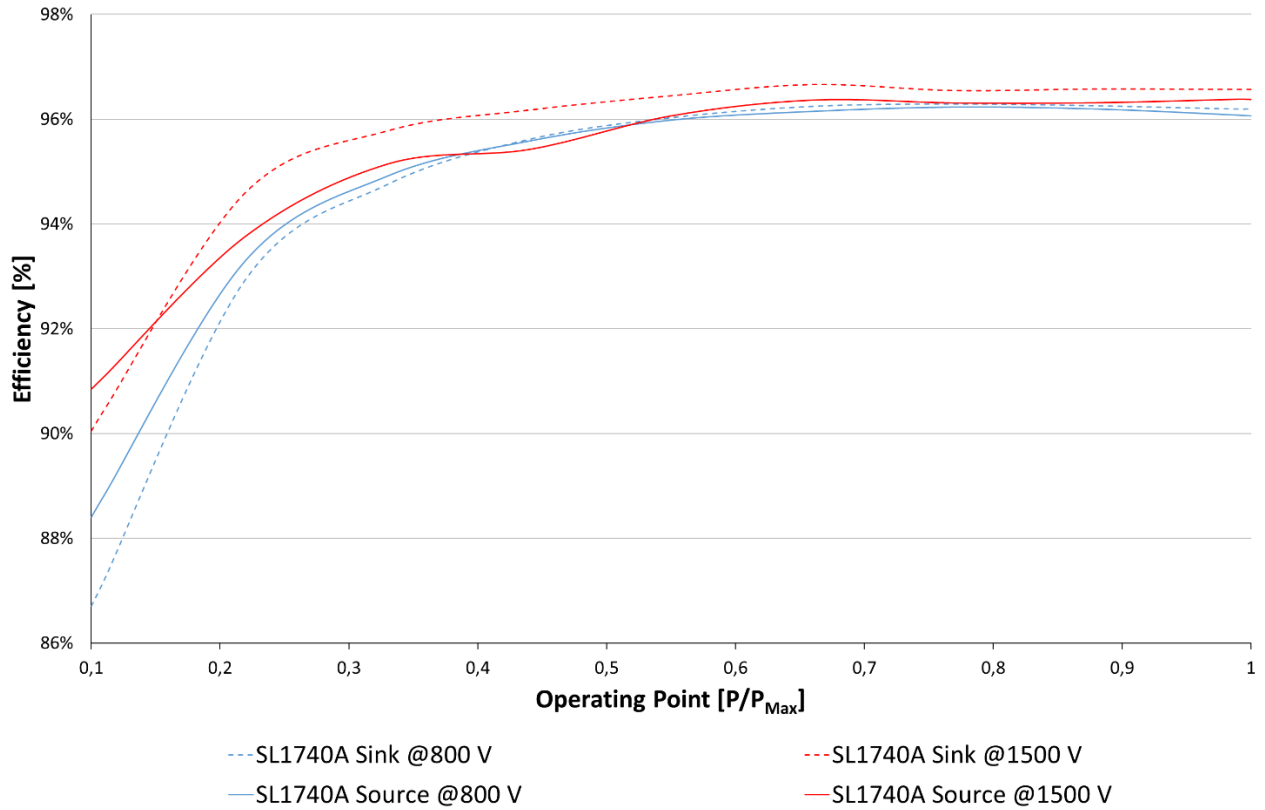

Figure 5. Efficiency curve SL1740A at 367 V, 800 V, and 1500 V.

Documentation

- Operating instructions in English
- CE Declaration of Conformity
- UL Declaration of Conformity
- KC Declaration of Conformity

System design and realization according to applicable safety and regulatory requirements (such as EU Directives). Special customer standards are not taken into account by default and require explicit agreement and quotation.

System Options

System type

SL17X0A-HOS Host system with Test Bench Control System

Battery Test System with an integrated industrial PC to control the overall test stand via the automation Software Energy Storage Discover.

SL17X0A-MBX Member system 1 to 5

Additional Battery Test System for increasing the power/current/channels of the battery test system group.

Additional features

SL17X0A-F01 Fine current range (200 A)

- Measuring range: ± 200 A
- Accuracy: $\pm 0.03\%$ of measured value, ± 40 mA (offset)

SL17X0A-F03 Fine current range (50 A)

- Measuring range: ± 50 A
- Accuracy: $\pm 0.03\%$ of measured value, ± 10 mA (offset)

SL17X0A-F02 Fine voltage range (20 to 300 V)

- Voltage Range: 20 to 300 V
- Accuracy: $\pm 0.03\%$ of measured value, ± 45 mV (offset)

Note: The available output power of the system will be halved when operating in the fine voltage range.

SL17X0A-DCE DC emulator option

Enhancement of the Battery Test System to be used as a DC emulator

Specifications	SL1710A/SL1720A	SL1730A	SL1740A
Voltage accuracy ¹	±0.03% of measured value, ±150 mV		
Supplemental Characteristics			
	SL1710A/SL1720A	SL1730A	SL1740A
Voltage ripple ²	Typical: 100 mV _{eff} @ 600 kHz bandwidth Maximum: 550 mV _{eff} @ 9.67 MHz bandwidth		
Output capacity	9.2 µF	18.3 µF	27.51 µF
Load stability	Typical: <40 V and <3 ms @ 300 V		Typical: <50 V and <5 ms @ 300 V
	Load jump: 0 → ±250 A < 1 ms	Load jump: 0 → ±500 A < 1 ms	Load jump: 0 → ±800 A < 1 ms
	Load capacitance: 400 µF	Load capacitance: 400 µF	Load capacitance: 400 µF
Sample rate	1 kHz		

¹ Measurement and programming accuracy; measurement with Number of Power-Line-Cycles (NPLC) = 100; valid for 1 year.

² Test condition: Load capacitance of 400µF is used.

Cabinet base option class

SL17X0A-C01 Base stand

Battery Tester is placed on top of the base stand.

SL17X0A-C02 Rollers

Battery Tester is placed on top of heavy-duty rollers and can be moved flexibly.

Additional cabinet options

SL17X0A-C03 Mirrored cabinet layout

To provide a higher flexibility for the lab design a mirrored cabinet layout is available. The modular hardware design enables due to front access and easy positioning of the systems side-by-side or back-to-back. Benefit from a faster, less expensive installation incl. less cables.



Figure 6. Mirrored design and standard design (from left to right), front view.



Figure 7. Mirrored design and standard design (from left to right), top view.

SL17X0A-C04 Halogen-free cables

Cabling inside the system cabinet with halogen-free material.

SL17X0A-C05 Cabinet interior lighting

Illumination of the output terminals in the control cabinet.

Safety functions

SL17X0A-T01 Insulation monitor

Insulation monitor Bender iso685 to supervise the isolation value of the connected DUTs.

SL17X0A-T02 Insulation monitor – key switch

Key switch for enable/disable the insulation monitor. The following operation modes are available:

0: Auto, 1: Off, 2: On

SL17X0A-T03 Test Bench Guard

Beckhoff Industrial PC and safety programmable logic controller (PLC) for operating a battery test stand in a safe and supervised condition. The individual safety matrix is the backbone of the system and defines the reaction of the safety measures in a certain situation. The safety matrix is always tailored to the customer's hazard and risk analysis.

SL17X0A-T04 Redundant current/voltage measurement

- Redundant DUT current and voltage measurement to maintain the safety of the test stand.
- Only available with Test Bench Guard.

Upgrade options

Power upgrades

Extension of the SL1720A or SL1730A system with an additional 90 kW or 100 kW/300 A power stage.

- SL1700AU-PB1 Power upgrade (SL1720A to SL1730A)
- SL1700AU-PB2 Power upgrade (SL1720A to SL1740A)
- SL1700AU-PB3 Power upgrade (SL1730A to SL1740A)

Voltage upgrades

Extension of the voltage range to 1200 V or 1500 V.

- SL1700AU-VB1 Voltage upgrade (1000 V to 1200 V)
- SL1700AU-VB2 Voltage upgrade (1000 V to 1500 V)
- SL1700AU-VB3 Voltage upgrade (1200 V to 1500 V)

Current upgrades

Increase the output current of a system. If the maximum achievable current is already reached (see table on page 3), further increase is only possible with additional hardware (power upgrade or an additional system connected in parallel).

- SL1700AU-CB1 Current upgrade (300 A to 600 A)
- SL1700AU-CB2 Current upgrade (300 A to 900 A)
- SL1700AU-CB3 Current upgrade (600 A to 900 A)

Project Management, Consulting and Installation Services

Service features depend on the facilities, customer expertise, and overall scope of the project. For that reason, it is not possible to give exact service efforts without knowing the customer's requirements and goals. Keysight offers the following services to secure a successful project execution and reduce ramp-up time for our customers.

PS-XPM-100-SL Project management services

Keysight recommends Project management services for each test bench project. By ordering the Project management services, an experienced project manager is dedicated to your project and acts as a direct communication interface from Keysight to the customer's project management team.

The project manager takes over the responsibility:

- To develop and manage the project plan.
- To track project progress and milestones.
- Communication project status regularly and ensure any unscheduled project events or project deviations are communicated and promptly discussed with the customer project team.
- To provide complete and accurate project documentation to the customer.

PS-XINS-100-SL Project installation services

These services provide installation expertise to manage, deliver and coordinate local facilities installation for the test bench. Specific installation efforts depend on the customer's individual facility, the locally available power and cooling and the test bench being delivered.

PS-XENG-100-SL Project engineering services

Project engineering services provide specialized engineering services during project development and implementation. The customer's project team will have access to engineering expertise to aid in various tasks specific to their project including but not limited to – safety matrix and test bench guard, facilities and lab layout, special power requirements, etc.

PS-XCOM-100-SL Project commissioning services

Project commissioning services for the test solution provide an experienced test bench engineer to validate and complete the test bench setup in readiness for the customer's initial usage. It includes validating specific hardware and software configurations per the project requirements and any specific consulting agreed to beforehand, given the test bench's customer-specific usage.

KeysightCare for Solutions

KeysightCare for Solutions services goes beyond basic warranty, providing a priority-one connection between our resources and your teams. Every support tier includes access to the Keysight Support Portal and Knowledge Center where you can find answers, manage service requests, and interact with Keysight experts familiar with the instruments and software you are using and the challenges you face. And all the packages offer onsite options for large systems which cannot be moved.

- Warranty Plus – Reduce risk and avoid project delays with technical support coverage.
- Assured – Increase supportability to match your application needs with a committed turnaround time.
- Enhanced – Keep your project schedules on track and receive priority support and even faster turnaround times for repairs and calibration to optimize your solution.

Service deliverables

	KeysightCare for Solutions Warranty Plus	KeysightCare for Solutions Assured	KeysightCare for Solutions Enhanced
	Onsite Upgrade R-55T-005- X ¹	Onsite Upgrade R-55U-005-X ¹	Onsite Upgrade R-55V-006-X ¹
Solution technical support (SW² & HW)			
Keysight Support Portal & Knowledge Center, 24x7	•	•	•
Remote technical support response time ³	2 business days	4 business hours	2 business hours
Onsite Technical Support ⁴		•	•
Solution hardware support			
Repair service coverage	Onsite	Onsite	Onsite
Onsite response time	No commitment	12 business days response time ⁶	5 business days response time ⁶
Solution calibration ⁷			Up to Keysight calibration + uncertainty + guard banding - Onsite
Calibration turnaround time			Scheduled
Application of service notes	Safety and recalls	Recommended - during service	Recommended - proactive
Preventative maintenance ⁵			•
Proactive firmware release notifications		•	•

¹ When ordering, update with the relevant (Solution Product Number (SPN) based on the length of service required (e.g. -1, -2, -3, or -5 for 1 year, 2 years, 3 years or 5 years).

² KeysightCare Software Agreement required for software support.

³ Remote Technical Support Response time is measured from the time you contact the KTAS team to have an initial meaningful response from the case owner.

⁴ Onsite technical support is provided or at the discretion of Keysight.

⁵ 3rd party products are excluded for assured and enhanced packages.

⁶ Response time is measured from the date the service request is received to the date Keysight arrives at your site.

⁷ Recommended re-calibration period is 12 months.

Find out more about KeysightCare Service and Support [here](#).

Extend the Capabilities of your Scienlab Battery Test System

Keysight provides battery test system software that starts with Scienlab Energy Storage Discover to control your individual battery test systems such as the SL1000A and extends to PathWave Lab Operations for Battery Test to manage and coordinate your entire battery testing laboratory with multiple systems used to test cells, modules, and battery packs.

SL1091A Scienlab Energy Storage Discover

Scienlab Energy Storage Discover (ESD) is the intuitive test-software environment for developing, performing, and analyzing tests for an individual test system.



Figure 8. Scienlab Energy Storage Discover controls individual test systems.

- Central controlling component for all Keysight Scienlab-brand energy storage test environments.
- Comprehensive overview, user-friendly operation, easy-to-learn.
- Powerful visualization of tests and results.
- ESD supports creating test programs even offline.
- Available simulation environment for offline test.
- Ethernet communication with the battery test system.
- Easy integration with external control and monitoring software via optional standardized remote interface.
- Holistic vehicle emulation from the perspective of battery cell, module and pack levels.
- Support for Windows 10. Single software license per workstation.
- Integration of external components into the test environment and process, such as environmental chambers, cooling and heating equipment, or optional Scienlab-brand Measurement and Control Modules.

Find out more about Scienlab Energy Storage Discover [here](#).

EP1150A PathWave Lab Operations for Battery Test

PathWave Lab Operations for Battery Test enables efficient planning and coordination of your entire battery test laboratory. It manages all resources, including test facilities, test systems, and your test objects or devices under test (DUTs). PathWave Lab Operations for Battery Test provides an integrated, web-based lab management platform that helps you modernize your test workflows, eliminating legacy paper-based processes, and increasing data integrity and traceability.

This powerful tool helps you to improve test throughput for all the cells and batteries you need to test, to fulfill the testing requirements for your projects on-schedule, and to optimize test asset utilization.

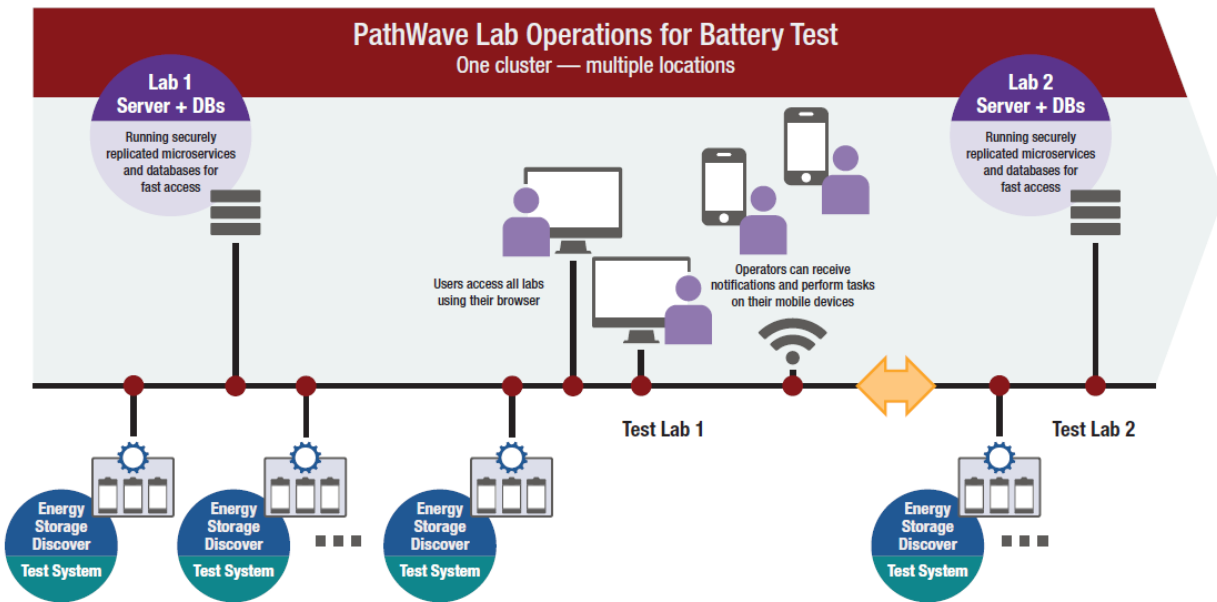

Figure 9. PathWave Lab Operations for Battery Test manages multiple test systems in a laboratory.

- Easily register and track test objects in your lab.
- Quickly analyze your data and statistics.
- Organize your test lab workflow, documents, lab orders, and tasks.
- Plan and optimize your test capacities and sequences.
- Share and control test plans, results, data, and other documents. Collaboration and discussion among lab staff become easy and productive.
- Remotely control your lab and its devices anywhere, anytime.
- Manage and route notifications to your preferred device or email service.
- Automated, networked, and scalable for any size of testing lab – up to thousands of channels.

Find out more about PathWave Lab Operations for Battery Test [here](#).

Meet the SL106XX Series Scienlab Measurement and Control Module

The Scienlab SL106XX Series covers a wide range of test, measurement, and control tasks. If required, you can combine your measurement task and scope.

They are ideal for carrying out challenging measurement tasks, even under difficult environmental conditions, for example, a climate chamber. The modules offer top quality, robustness, and easy and intuitive operation.

- Precise, reproducible, and time-synchronous measurement data recording
- Fully electrically isolated measurement channels up to 1000 V insulated between each channel
- Connection via open Ethernet interface; automatic detection of Scienlab Energy Storage Discover (ESD) software
- Easy to use in challenging test environment (-40 to +80 °C, IP20)
- Individual combination of different measurement module types

Find out more about the Scienlab Measurement and Control Modules [here](#).