

Digital Laser Doppler Vibrometer Nova-Series



OptoMET Laser Doppler Vibrometers (LDV) are very fast and easy-to-operate vibration measuring instruments. They are used for precise, non-contact, and non-reactive measurements of mechanical and acoustic parameters such as vibration displacement, velocity and acceleration.

Thanks to our innovative digital signal processing technology and the highest optical sensitivity, our instruments provide quick and simple vibration measurements of even the most challenging systems, including high vibration frequencies, large working distances, small vibration amplitudes, high linearity, and high accelerations or velocity.

HIGH-END UND BEST-PERFORMANCE

The „Nova-Series“ Laser Vibrometer operates with an invisible SWIR Laser (1550 nm), which has 10 times more output power than classical red HeNe-Laser, nevertheless it is as well eye-safe (Class I).

Due to this powerful infrared laser the „Nova-Series“ vibrometer are especially suited for measurements on difficult surfaces, long working distances or very high frequency applications. With the different objective lenses inclusive a collimating lens the working distance varies from 0 mm to >300 m.

Applications are found in automotive-, manufacturing-, aerospace industry, material research & testing and civil engineering.

Ideal for:

- Dark / rough surfaces
- Very high frequency vibrations
- Biological surfaces
- Moving or rotating objects
- High speed vibrations up to 24.5 m/s
- Long distance measurements

General data

Measured quantity	Velocity, displacement, acceleration
Frequency bandwidth	0 Hz - 10 MHz
Signal processing	Digital (OptoMET UltraDSP)
Source impedance	50 Ohm
Working distances	Variable working distance from 0 mm to >300 m
Laser wavelength	Measurement laser: 1550 nm, Targeting laser: 510-530 nm
Laser safety class	Measurement laser: output power: <10 mW, class 1 Targeting laser: output power: <1 mW, class 2
Optics	Auto- and manual focusing
User interface output	Color screen 3.5" + 20 segment LED bargraph
User interface input	Touch screen, knobs with push-button, key switch (power)
Operating temperature range	+5 to 40°C
Dimensions	Length x width x height (excluding handle and lens): 380 x 180 x 148 mm
Weight	8 kg + objective lens
Power supply	110 -240 V AC (50-60Hz) or 12 V DC
Analog output	- Up to 3 BNC analog outputs - Data rate: 160 MSamples/s @ 16-bit - Output voltage range: ± 2 V
Ethernet digital output	- Data rate: 1 GBit (53.3 MSamples/s @ 16-bit) - With a data acquisition- and analysis software - Remote control feature

Configuration

Specification	Nova-Basis	Nova-Sense	Nova-Remote-Sense	Nova-Speed	Nova-HF	Nova-Master
Frequency range	DC - 500 kHz	DC - 1 MHz	DC - 25 kHz	DC - 2.5 MHz	DC - 10 MHz	DC - 10 MHz
Velocity-decoder	D-VD-1N	D-VD-2N	D-VD-2N-R	D-VD-3N	D-VD-4N	D-VD-5N
Velocity measuring ranges	24.5 mm/s - 5 m/s	2.45 mm/s - 5 m/s	2.45 mm/s - 5 m/s	24.5 mm/s - 24.5 m/s	24.5 mm/s - 12 m/s	2.45 mm/s - 24.5 m/s
Number of velocity measuring ranges	8	11	11	11	9	14
Displacement-Decoder	D-DD-1N	D-DD-2N	D-DD-2N-R	D-DD-3N	D-DD-4N	D-DD-5N
Displacement measuring ranges	± 122.5 nm - ± 122.5 mm					
Number of Displacement measuring ranges	19					
Displacement high pass filter	25 Hz / 20 kHz	25 Hz / 20 kHz	0.16 Hz / 7 Hz / 50 Hz	25 Hz / 20 kHz	25 Hz / 20 kHz	25 Hz / 20 kHz
Acceleration-Decoder	D-AD-1N	D-AD-2N	D-AD-2N-R	D-AD-3N	D-AD-4N	D-AD-5N
Acceleration measuring ranges	392 g - 1.6 Mg	3.9 g - 3.2 Mg	3.9 g - 80000 g	392 g - 39.2 Mg	392 g - 76.8 Mg	3.9 g - 39.2 Mg
Number of Acceleration measuring ranges	8	11	11	11	9	14
Low pass filters	2.5, 5, 10, 20, 50, 100 kHz					
Trackingfilter	slow / fast					

Set-up

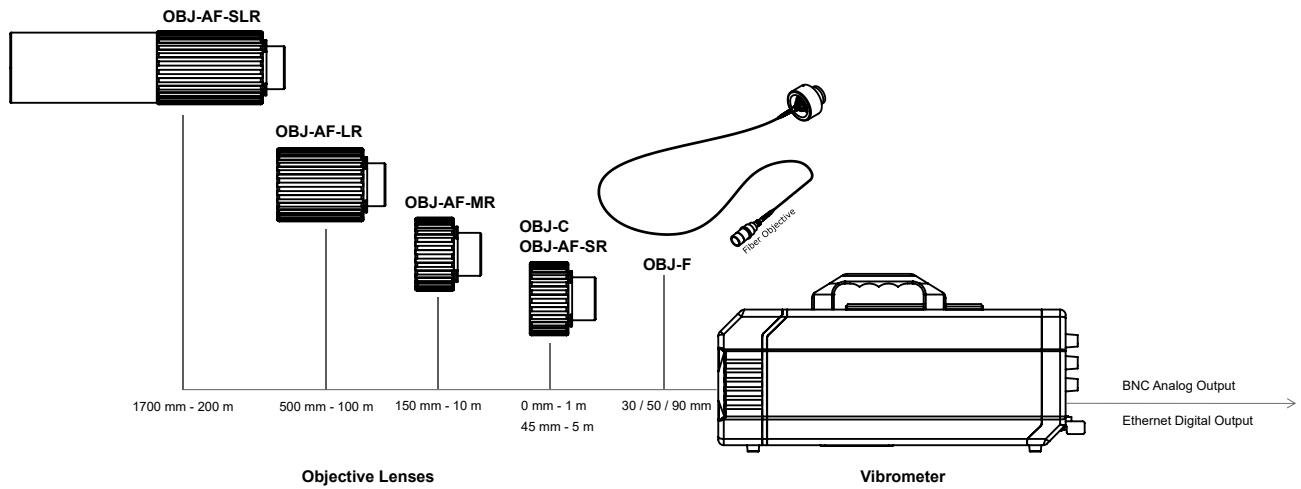

Objective lens

Spezifikationen	OBJ-C	OBJ-F	OBJ-SR	OBJ-MR	OBJ-LR	OBJ-SLR
	Collimated	Fiber objective Manual	Short-Range Manual / Autofocus	Mid-Range Manual / Autofocus	Long-Range Manual / Autofocus	Super-Long-Range Manual / Autofocus
Focal length (mm)	-	40 / 60 / 100	25	50	100	200
Min. stand-off distance (mm)	0	30 / 50 / 90	45	150	500	1700
Min. Spot size in μm	1400	11.6 / 17.6 / 35.8	50	60	130	170
Working distance	0 ... 1 m	30, 50, 90 mm	45 mm ... 5 m	150 mm ... 10 m	500 mm ... 100 m	1.7 m ... >300 m

Dimension of the Vibrometer

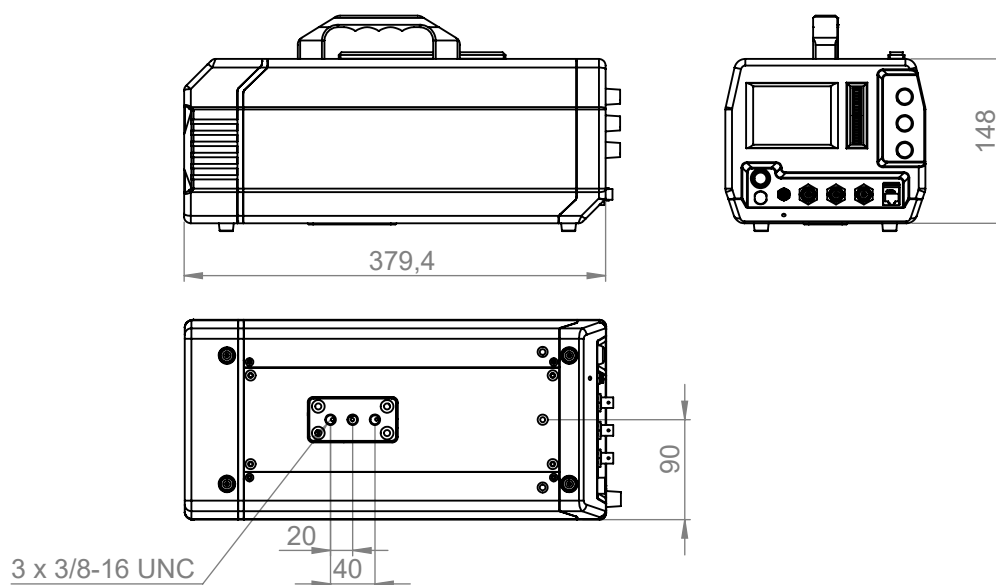

Indicator / operating

1	Touch screen LCD 3.5-Inch
2	Signal Level
3	Displacement measuring ranges
4	Velocity measuring ranges
5	Acceleration measuring ranges
6	Ethernet
7	Output acceleration
8	Output velocity
9	Output displacement
10	Power
11	Lock
12	Laser

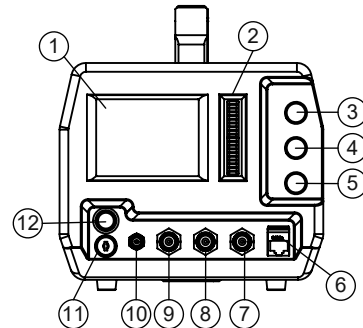

Laser product label

DO NOT STARE INTO BEAM Class 2 Laser Product

Laser CLASS 1: invisible, 1550 nm, output power: <10 mW

Laser CLASS 2: visible, green laser beam, 510-530 nm, output power: <1 mW

