



Advanced Test Equipment Corp.

www.atecorp.com 800-404-ATEC (2832)

NAVSEA ST700-AA-MMO-010/MODEL 3657

NAVSEA ST700-AA-MMO-010/MODEL 3657

TECHNICAL MANUAL

INSTALLATION, OPERATION, MAINTENANCE

KING NUTRONICS

PORTABLE CALIBRATION SYSTEM MODEL 3657, PART NUMBER 3657-1-1

KING NUTRONICS
Contract Number N00140-77-C-0482

NOTICE

This manual contains information proprietary to King Nutronics Corporation and use or reproduction of the information or illustrations contained herein is expressly prohibited without specific prior written approval of King Nutronics Corporation.

Each transmittal of this document outside of the Department of Defense must have approval of the Issuing Service

Published by direction of Commander, Naval Sea Systems Command

1 NOVEMBER 1978

Reproduction for non-military use of the information or illustrations contained in this publication is not permitted. The policy for military use reproduction is established for the Army in AR 380-5, for the Navy and Marine Corps in OPNAVINST 5510.1B, and for the Air Force in Air Force Regulation 205-1.

LIST OF EFFECTIVE PAGES

Insert latest changed pages; dispose of superseded pages in accordance with applicable regulations.

NOTE: On a changed page, the portion of the text affected by the latest change is indicated by a vertical line, or other change symbol, in the outer margin of the page. Changes to illustrations are indicated by miniature pointing hands. Changes to wiring diagrams are indicated by shaded areas.

Total number of pages in this manual is 80 consisting of the following:

Page No.	# Change No.
Title	0
A	0
Change Record	0
APR Page	0
Content Assurance Page	0
Blank	0
i - iii	0
1-0 - 1-4	0
2-1 - 2-14	0
3-1	0
3-2 Blank	0
4-1 - 4-2	0
5-1 - 5-7	0
5-8 Blank	0
6-1 - 6-11	0
6-12 Blank	0
7-1 - 7-22	0
8-1 - 8-5	0
8-6 Blank	0

Zero in this column indicates an original page.

RECORD OF CHANGES

CHANGE NO.	DATE	TITLE OR BRIEF DESCRIPTION	ENTERED BY

APPROVAL AND PROCUREMENT RECORD PAGE

APPROVAL DATA FOR: NAVSEA _____
 TITLE OF MANUAL:

APPROVAL AUTHORITY:

CONTRACT NUMBER	SHIP APPLICABILITY	QUANTITY OF MANUALS	QUANTITY OF EQUIPMENT	BUILDING YARD
N00140-77-C-0482	CV-67, -66, -64, -63, 62, 60 CVA-61 CG-26 Class CG-16 Class DDG-37 Class DDG-35, -36 DDG-31 Class DDG-2 Class DD-745 Class DD-931 Class FFG-1 Class FF-1052 Class FF-1040 Class FF-1037, -1038	2 per System	158 Systems	N A

REMARKS:

 CERTIFICATION: DATE _____

 MANUFACTURER'S SIGNATURE
 MANUFACTURER'S NAME AND
 ADDRESS
 FEDERAL CODE NUMBER (HOME
 OFFICE)

VALIDATION PERFORMANCE

Title of Publication

NAVSEA Number
or NAVELEX NUMBER

Contractor:

Sub-Contractor (if performing
validation):

Contract No(s) and Purchase Orders, if applicable

Chapter	Section	Paragraph	Date Validation Completed	Check here if

Name & Authority of Validating
Officer:

Signature of Validating Officer:

TABLE OF CONTENTS

Chapter	Page	Chapter	Page
LIST OF ILLUSTRATION	ii	6 CORRECTIVE MAINTENANCE	6-1
LIST OF TABLES	iii	6-1. Introduction	6-1
1 GENERAL INFORMATION	1-1	Section I – Adjustments and Alignments	
1-1. Introduction	1-1	6-3. General	6-1
1-3. Equipment Description and Relationship of Units	1-1	Section II – Repair	
1-14. Reference Data	1-2	6-5. General	6-1
1-16. Equipment, Accessories, and Documents Supplied	1-2	6-7. Vacuum Pump Case Assembly Removal and Disassembly	6-1
1-18. Equipment and Publications Required But Not Supplied	1-2	6-30. Hand Pump Case Assembly Removal and Disassembly	6-4
1-20. Field Changes and Factory Changes	1-2	6-37. Gauge Case Assembly Components Disassembly	6-5
2 OPERATION	2-1	6-42. Inspection	6-5
2-1. Introduction	2-1	6-47. Repair and Replacement	6-6
2-3. Controls, Indicators, and Operating Equipment	2-1	6-49. Cleaning	6-6
2-8. Vacuum Pump Case Assembly Operation	2-8	6-51. Gauge Case Assembly Components Reassembly	6-7
2-13. Head Pump Case Assembly Operation	2-11	6-55. Hand Pump Case Assembly Reassembly	6-8
3 FUNCTIONAL DESCRIPTION	3-1	6-60. Vacuum Pump Case Assembly Reassembly	6-8
3-1. Major Subassemblies	3-1	6-81. Adjustments	6-11
4 SCHEDULED MAINTENANCE	4-1	6-83. Installation	6-11
4-1. Introduction	4-1	6-85. Calibration	6-11
4-3. Scheduled Maintenance Action Index	4-1	6-87. Checkout	6-11
4-5. Preventive Maintenance Procedures	4-1	7 PARTS LIST	7-1
4-10. Scheduled Performance Tests	4-2	7-1. Introduction	7-1
5 TROUBLESHOOTING	5-1	7-3. List of Major Units	7-1
5-1. Introduction	5-1	7-5. Parts List	7-1
5-3. Troubleshooting	5-1	7-7. List of Manufacturers	7-1
		8 INSTALLATION	8-1
		8-1. Introduction	8-1
		8-3. Site Information	8-1
		8-5. Reference Publications	8-1
		8-7. Tools and Materials Needed for Installation	8-1
		8-9. Unpacking and Repacking	8-1
		8-11. Preparation of Foundation	8-1
		8-13. Input Requirements	8-1
		8-15. Installation Procedures	8-1
		8-17. Installation Checkout	8-1

LIST OF ILLUSTRATIONS

Number	Title	Page	Number	Title	Page
1-1	Portable Calibration System	1-0	7-2	Vacuum Pump Case Assembly, Part No. 3657-51-1 (2 sheets)	7-3
2-1	Vacuum and 15 Psig Gauge Case Assembly Indicators and Operating Equipment	2-0	7-3	Test Hose Assembly, Part No. 3460-104-1200	7-6
2-2	Vacuum Pump Case Assembly Controls, Indicators, and Operating Equipment	2-2	7-4	High-Pressure Quick-Disconnect Socket Assembly, Part No. 3460-7-1	7-7
2-3	30, 100, and 300 Psig Gauge Case Assembly and 1000, 3000, and 10,000 Psig Gauge Case Assembly Indicators and Operating Equipment	2-4	7-5	Metering Valve Assembly, Part No. 3112-27-1	7-8
2-4	Hand Pump Case Assembly Controls and Equipment (2 sheets)	2-6	7-6	Vernier Control Valve Assembly, Part No. 3534-9-1	7-9
2-5	Typical Low Pressure Gauge Calibration Set-Up	2-9	7-7	Hand Pump Case Assembly, Part No. 3657-45-1	7-10
2-6	Typical Vacuum Gauge Calibration Set-Up	2-10	7-8	High-Pressure Hose Assembly, Part No. 3657-59-0600 and 3657-59-1200	7-12
2-7	Filling Master Gauges	2-12	7-9	Adapter Kit, Part No. 3657-48-1	7-13
2-8	Typical High Pressure Gauge Calibration Set-Up	2-13	7-10	Hand Pump, Part No. 804-1-1	7-15
5-1	Vacuum Pump Fault Logic Diagram (2 sheets)	5-2	7-11	Gauge Case Assemblies, Part No. 3657-29-1 and 3657-29-3	7-17
5-2	Fluid Separator Fault Logic Diagram	5-4	7-12	Fluid Separator Assembly, Part No. 3460-54-1	7-19
5-3	High Pressure Hose and Test Hose Fault Logic Diagram	5-5	7-13	Gauge Case Assembly, Part No. 3657-28-1	7-20
5-4	Master Gauge Fault Logic Diagram	5-6	7-14	Relief Valve, Part No. 3460-150-15	7-22
5-5	Hand Pump Fault Logic Diagram	5-7	8-1	Unpacking Master Gauges	8-2
6-1	Inspection of High-Pressure Hose	6-6	8-2	Installation Drawing – Vacuum and 15 Psig Gauge Case and Vacuum Pump Case Assembly	8-3
6-2	Fluid Separator Torque Sequence	6-7	8-3	Installation Drawing – 30, 100, 300 Psig Gauge Case Assembly and 1000, 3000, 10,000 Psig Gauge Case Assembly	8-4
6-3	Packing and Retainer Installation	6-9	8-4	Installation Drawing – Hand Pump Case Assembly	8-5
7-1	Portable Calibration System, Model 3657, Part No. 3657-1-1	7-2			

LIST OF TABLES

Number	Title	Page	Number	Title	Page
1-1	Reference Data	1-2	2-3	30, 100, and 300 Psig Gauge Case Assembly and 1000, 3000, and 10,000 Psig Gauge Case Assembly Indicators and Operating Equipment	2-5
1-2	Equipment, Accessories, and Documents Supplied	1-5	2-4	Hand Pump Case Assembly Controls and Equipment	2-5
2-1	Vacuum and 15 Psig Gauge Case Assembly Indicators and Operating Equipment	2-1	4-1	Scheduled Maintenance Action Index	4-1
2-2	Vacuum Pump Case Assembly Controls, Indicators, and Operating Equipment	2-3	5-1	Troubleshooting Index	5-1

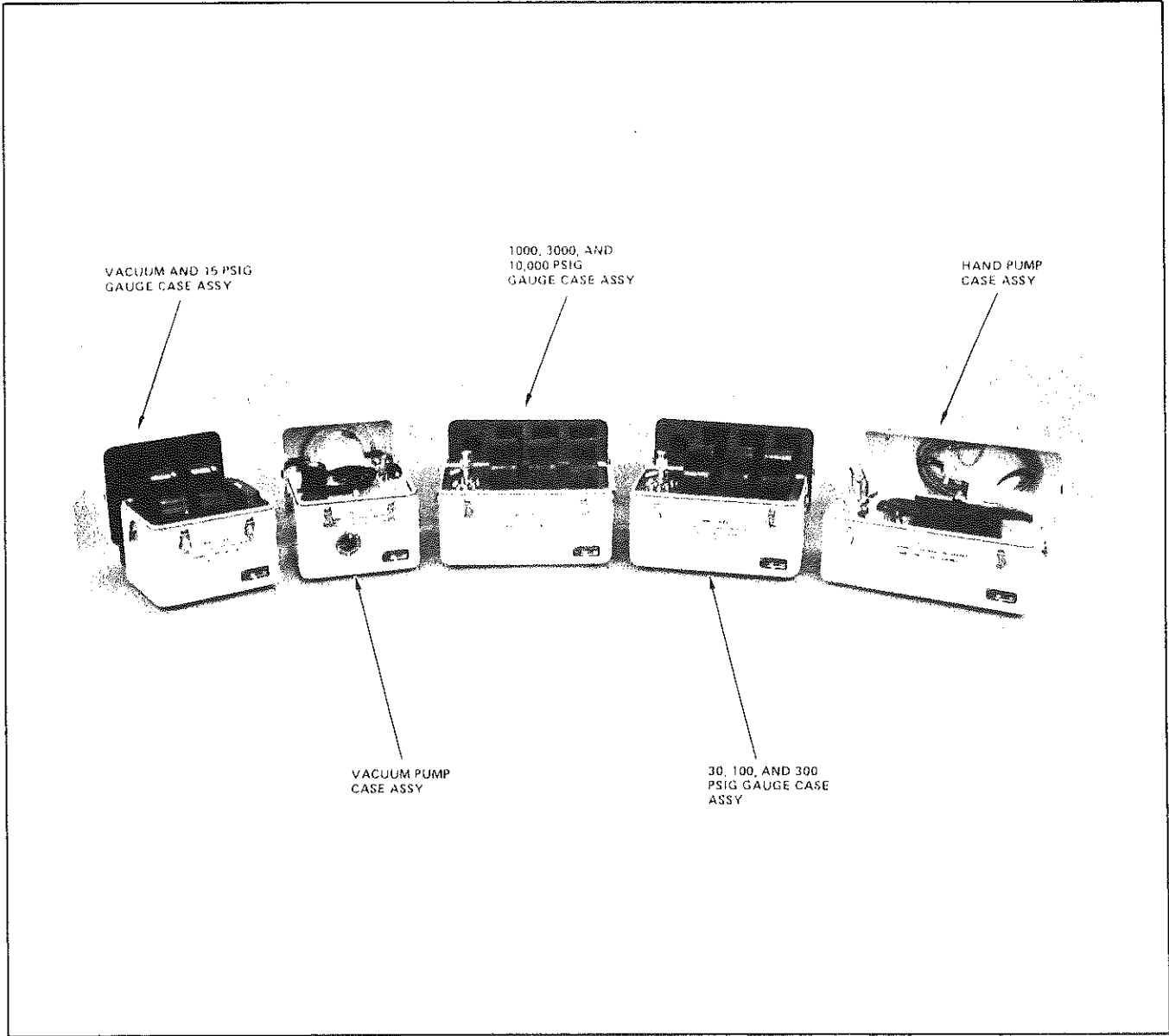

Figure 1-1. Portable Calibration System

CHAPTER 1

GENERAL INFORMATION

1-1. INTRODUCTION

1-2. This technical manual contains description, operation, installation, and maintenance instructions for Portable Calibration System, Model 3657, Part No. 3657-1-1, manufactured by King Nutronics Corporation, 6421 Independence Avenue, Woodland Hills, California 91367.

1-3. EQUIPMENT DESCRIPTION AND RELATIONSHIP OF UNITS

1-4. The portable calibration system consists of a vacuum and 15 psig gauge case assembly; a vacuum pump case assembly; a 1000, 3000, and 10,000 psig gauge case assembly; a 30, 100, and 300 psig gauge case assembly; and a hand pump case assembly (see figure 1-1). The portable calibration system is intended for use in the precision calibration of vacuum gauges, pressure gauges, transducers, and other pressure sensitive devices at pressures from 30 inches mercury vacuum to 10,000 psig. Accuracy of calibration is 0.1 percent of the range of the master gauge being used for calibration. The portable calibration system is designed to be transported and operated by one man.

1-5. **VACUUM AND 15 PSIG GAUGE CASE ASSEMBLY.** The vacuum and 15 psig gauge case assembly consists of a 0 to 15 psig master gauge, 0 to 30-inches Hg (vacuum) gauge, a filter, a packing kit assembly, and a case assembly. The gauge case is an aluminum carrying case lined with shock-absorbant material to protect the gauges. A stainless-steel probe is installed in the inlet port of each gauge. A dust cover is chained to each probe to prevent contamination or damage to the gauge when not in use. The equipment of the vacuum and 15 psig gauge case assembly is used in conjunction with vacuum pump case assembly.

1-6. **VACUUM PUMP CASE ASSEMBLY.** The vacuum pump case assembly consists of chassis assembly installed in an aluminum carrying case. Mounted on the chassis are baumanometer bulb assembly for generating pressures up to 15 psig, a compound gauge providing nominal indications of test pressure or vacuum level, a vernier control valve for precision control of test pressure or vacuum level, test ports for attaching a master gauge and gauge under calibration, and shutoff and metering valves. Within the chassis is an electric motor driven vacuum pump. A ten-foot test hose stored in the lid of the case allows test connections to be made at remote panel location. All components are housed within an aluminum carrying case. The vacuum pump case assembly is used in conjunction with the vacuum and 15

psig gage case assembly to calibrate vacuum and low pressure gauges and transducers. A relief valve is installed in the test circuit to prevent overpressuring the master and test gauges.

1-7. **PRESSURE GAUGE CASE ASSEMBLIES.** The two gauge cases each consist of three master gauges, a fluid separator, and a liquid charger housed in an aluminum carrying case lined with shock-absorbant material. In one case, master gauges are provided in 30, 100, and 300 psig maximum pressure ranges. In the second case, master gauges are provided in 1000, 3000, and 10,000 psig maximum pressure ranges. Each gauge is equipped with a stainless steel probe that mates with the quick-disconnect sockets used throughout the portable calibration system. A dust cover is installed on each probe to prevent contamination or damage when not in use.

1-8. The fluid separators are used for calibration of oil system gauges and act as a medium barrier between the water used in test system and the oil used in a hydraulic gauge under test. One fluid separator uses compressor oil and the second separator uses hydraulic oil. A probe is installed on the water side of the fluid separators to mate with the couplings of the hand pump manifold assembly or the test hose. A quick-disconnect socket is installed on the oil side of the fluid separator to mate with the adapter of the gauge to be calibrated.

1-9. The liquid chargers are plastic bottles used to charge the separators with compressor oil and hydraulic oil. The chargers are labeled for identification of fluid content.

1-10. **HAND PUMP CASE ASSEMBLY.** The hand pump case assembly contains the components necessary to provide test pressures for gauge calibration. All components are housed within an aluminum carrying case. The lid of the case contains a five-foot and a ten-foot high-pressure hose. The case contains a hand pump assembly, an adapter kit, and a copy of the technical manual.

1-11. The hand pump provides a source of hydraulic pressure for calibrating gauges used in gas, water, or hydraulic systems. A manifold assembly is installed in the outlet port of the hand pump and is equipped with two quick-disconnect sockets for mounting a reference gauge and the gauge to be calibrated. The manifold assembly contains a vernier control valve for precision control of the test pressure. A long drip pan is bolted to the hand pump assembly to catch the fluid leakage. The hand pump can be removed from the case, if desired, by removing four bolts.

1-12. The adapter kit contains an assortment of probe adapters used to adapt the gauge under calibration to the quick-disconnect sockets used in the portable calibration system.

1-13. The high-pressure hoses are used to permit remote calibration of a panel-mounted gauge. One hose is five feet in length and the other is ten feet in length. Each hose is equipped with a probe at one end and a quick-disconnect socket at the other.

1-14. REFERENCE DATA

1-15. Refer to table 1-1.

1-16. EQUIPMENT, ACCESSORIES, AND DOCUMENTS SUPPLIED

1-17. Refer to table 1-2.

1-18. EQUIPMENT AND PUBLICATIONS REQUIRED BUT NOT SUPPLIED

1-19. All required equipment and publications are supplied.

1-20. FIELD CHANGES AND FACTORY CHANGES

1-21. There are no field changes or factory changes that apply to this equipment.

Table 1-1. Reference Data

<p>Manufacturer King Nutronics Corporation 6421 Independence Avenue Woodland Hills, CA 91367</p> <p>General:</p> <p>Test Fluid Distilled water</p> <p>Environmental Design Criteria</p> <p>Operating Temperature +40 to +125°F</p> <p>Storage Temperature (dry) -20 to +160°F</p> <p>Relative Humidity Up to 100%</p> <p>Resistant to Effects of Rainfall and salt atmosphere</p> <p>Handling Shock Free fall drop of 36 inches on concrete (cases Closed)</p> <p>Lubricants Fluorolubes greases</p> <p>Hand Pump Case Assembly:</p> <p>Discharge Pressure 0 to 10,000 psig</p> <p>Reservoir Capacity 75 cubic inches</p> <p>Piston Displacement:</p> <p>High Volume 0.179 cubic inches per stroke</p> <p>Low Volume 0.023 cubic inches per stroke</p> <p>Manifold Ports Two high-pressure quick-disconnect sockets for gauges</p>	<p>High-Pressure Hose Assembly:</p> <p>Inside Diameter 0.037-inch capillary</p> <p>Standard Length 5 feet and 10 feet</p> <p>Rated Pressure 10,000 psig</p> <p>Proof Pressure 15,000 psig</p> <p>Burst Pressure 40,000 psig (minimum)</p> <p>Construction Stainless-steel capillary sheathed in wire braided Teflon</p> <p>End Configuration High-pressure quick-disconnect (probe one end; female other end)</p> <p>Case Dimensions:</p> <p>Weight 21.00 inches</p> <p>Height 12.50 inches</p> <p>Depth 8.00 inches</p> <p>Weight 31 lbs maximum</p> <p>Vacuum Pump Case Assembly:</p> <p>Discharge Pressure 30 in. Hg (vacuum) to 15 psig (pressure)</p> <p>Vacuum Source Electric vacuum pump</p> <p>Pressure Source Baumanometer</p>
--	--

Table 1-1. Reference Data (Continued)

<p>Vacuum Pump Case Assembly (cont):</p> <p>Test Hose Assembly:</p> <p> Inside Diameter 1/8 nominal</p> <p> Standard Length 10 feet</p> <p> Rated Pressure 100 psig</p> <p> Proof Pressure 200 psig</p> <p> Burst Pressure 400 psid</p> <p> Construction Poly-flow plastic</p> <p> End Configuration High-pressure quick-disconnect (probe one end; female other end)</p> <p>Vacuum Pump:</p> <p> Electrical Requirements 115-volts, 60 Hz, 4 amperes max (2.5 amperes nominal-running)</p> <p> Power 1/8 HP</p> <p> Vacuum (maximum) 29-in. Hg</p> <p> Capacity 0.9 cfm at zero-in. Hg</p> <p> Lubricating Oil Vacuum pump oil (70 ml capacity)</p> <p>Vernier Control Valve:</p> <p> Displacement 3.0 cubic-in.</p> <p> Maximum Turns 72</p> <p>Construction:</p> <p> Body Aluminum</p> <p> Piston Stainless-steel</p> <p> Stem Stainless-steel</p> <p>Case Dimensions:</p> <p> Width 12.50 inches</p> <p> Height 13.00 inches</p> <p> Depth 10.50 inches</p>	<p>Weight 34 lbs maximum</p> <p>Vacuum and 15 Psig Gauge Case Assemblies:</p> <p>Reference Gauges:</p> <p> Type Bourdon tube with tip bleeder</p> <p> Dial 7-inch diameter with 310° arc (mirrored with black numerals on white face)</p> <p> Accuracy 0.1% full scale</p> <p> Sensitivity 0.037% full scale maximum</p> <p>Standard Range:</p> <p> Vacuum Gauge 0 to 30 in. Hg (600 divisions)</p> <p> Pressure Gauge 0 to 15 psig (750 divisions) and 0 to 400 in. H₂O (200 divisions)</p> <p> Port High-pressure male quick-disconnect probe</p> <p>Case Dimensions</p> <p> Width 12.50 inches</p> <p> Height 13.00 inches</p> <p> Depth 10.50 inches</p> <p>Weight 17 lbs maximum</p> <p>30-100-300 and 1000-3000-10,000 Gauge Case Assemblies:</p> <p>Reference Gauges:</p> <p> Type Bourdon tube with tip bleeder</p> <p> Dial 7-inch diameter with 310° arc (mirrored with black numerals on white face)</p> <p> Accuracy 0.1% full scale</p> <p> Sensitivity 0.037% full scale maximum</p>
---	---

Table 1-1. Reference Data (Continued)

<p>30-100-300 and 1000-3000-10,000 Gauge Case Assemblies (cont):</p> <p>Reference Gauges (cont):</p> <p>Standard Range 0 to 30 psig (600 divisions) 0 to 100 psig (1000 divisions) 0 to 300 psig (600 divisions) 0 to 1000 psig (1000 divisions) 0 to 3000 psig (600 divisions) 0 to 10,000 psig (1000 divisions)</p> <p>Port High-pressure male quick-disconnect probe</p> <p>Fluid Separator:</p> <p>Rated Pressure 10,000 psig</p> <p>Proof Pressure 15,000 psig</p> <p>Burst Pressure 40,000 psig (minimum)</p> <p>Capacity 3.0 cubic inches</p>	<p>Port Configuration High-pressure quick- disconnect (female coupling one end; male probe other end)</p> <p>Standard Diaphragm Material Buna-N (30 shore)</p> <p>Pressure Error Less than 0.01 psig</p> <p>Dimensions:</p> <p>Diameter 3.375 inches</p> <p>Length (including quick-disconnect) 7.6 inches</p> <p>Weight 5 pounds (dry)</p> <p>Liquid Chargers (capacity) 4 fluid ounces</p> <p>Case Dimensions:</p> <p>Width 18.06 inches</p> <p>Height 13.00 inches</p> <p>Depth 10.00 inches</p> <p>Weight 27 lbs maximum</p>
--	--

Table 1-2. Equipment, Accessories, and Documents Supplied

QTY	ITEM NAME OR NOMENCLATURE	APL/RIC NUMBER	OVERALL DIMENSIONS (IN.)	WEIGHT AND VOLUME
1	Vacuum and 15 Psig Gauge Case Assy		12.50 W x 13.00 H x 10.50 D	17 lbs max 0.99 cu ft
1	Vacuum Pump Case Assy		12.50 W x 13.00 H x 10.50 D	34 lbs max 0.99 cu ft
1	1000, 3000, 10,000 Psig Gauge Case Assy		18.06 W x 13.00 H x 10.00 D	27 lbs max 1.36 cu ft
1	30, 100, 300 Psig Gauge Case Assy		18.06 W x 13.00 H x 10.00 D	27 lbs max 1.36 cu ft
1	Hand Pump Case Assy		21.00 W x 12.50 H x 8.00 D	31 lbs max 1.22 cu ft
1	Technical Manual – Description, Operation, Installation, and Maintenance Instructions, Portable Calibration System Model 3657, Part Number 3657-1-1		8-1/4 W x 10-3/4 H x 1/8 D	3-1/2 oz max 11.09 cu in.

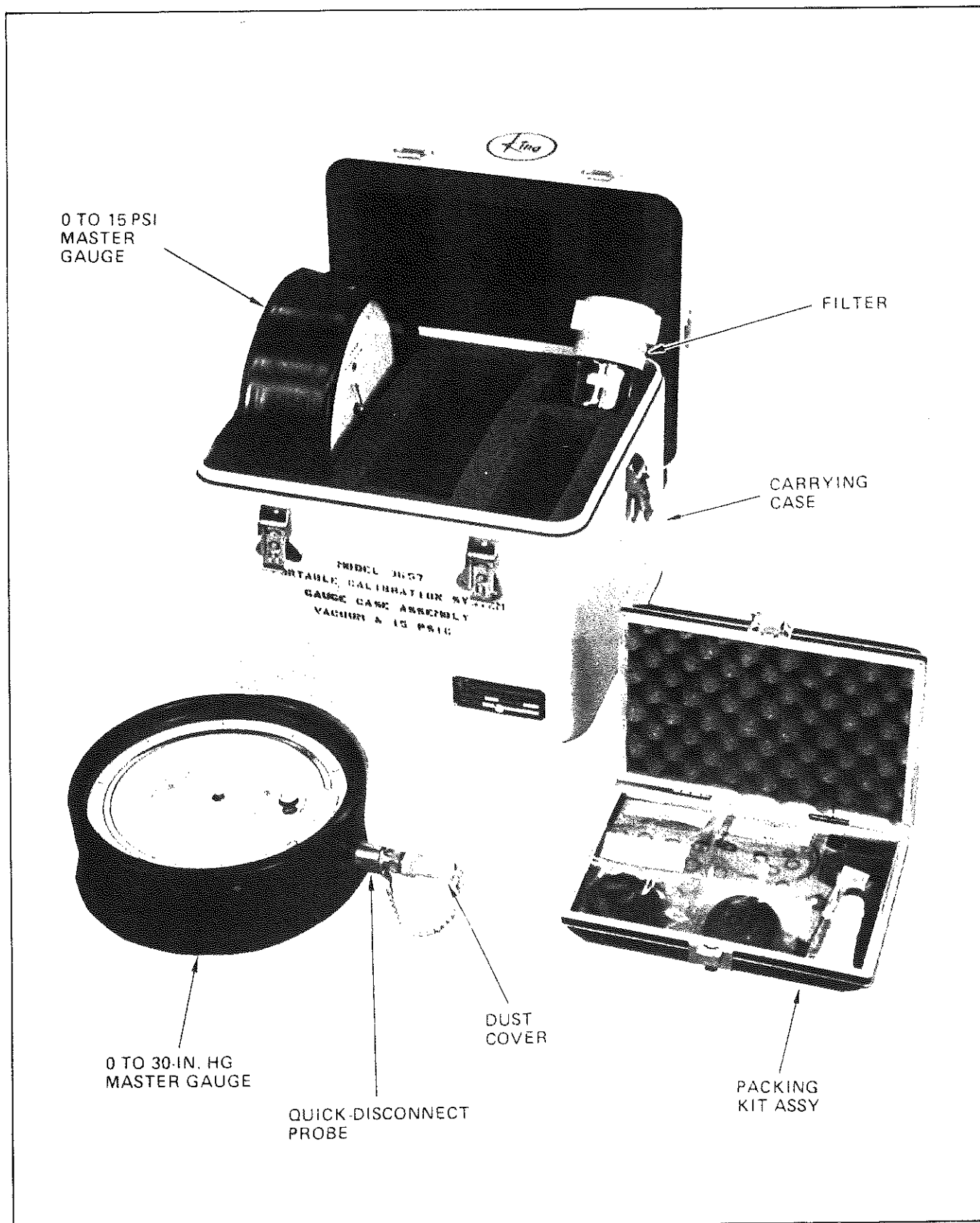

Figure 2-1. Vacuum and 15 Psig Gauge Case Assembly Indicators and Operating Equipment

CHAPTER 2 OPERATION

2-1. INTRODUCTION

2-2. This chapter contains the description of the operation procedure for the portable calibration system.

2-3. CONTROLS, INDICATORS, AND OPERATING EQUIPMENT

2-4. VACUUM AND 15 PSIG GAUGE CASE ASSEMBLY. Refer to table 2-1 and figure 2-1 for information covering the indicators and operating equipment of the vacuum and 15 psig gauge case assembly.

2-5. VACUUM PUMP CASE ASSEMBLY. Refer to table 2-2 and figure 2-2 for information covering the controls,

indicators, and operating equipment of the vacuum pump case assembly.

2-6. 30, 100, AND 300 PSIG GAUGE CASE ASSEMBLY AND 1000, 3000, AND 10,000 PSIG GAUGE CASE ASSEMBLY. Refer to table 2-3 and figure 2-3 for information covering the indicators and operating equipment of the 30, 100, and 300 psig gauge case assembly and the 1000, 3000 and 10,000 psig gauge case assembly.

2-7. HAND PUMP CASE ASSEMBLY. Refer to table 2-4 and figure 2-4 for information covering the controls and equipment of the hand pump case assembly.

Table 2-1. Vacuum and 15 Psig Gauge Case Assembly
Indicators and Operating Equipment

CONTROL, INDICATOR, OR EQUIPMENT	OPERATING FUNCTION
0 to 15 Psi Master Gauge	Reference gauge for calibrating pressure sensitive gauges, transducers, and other pressure sensitive devices in the pressure range from 0 to 15 psig. The gauge is calibrated from 0 to 15 psig with 750 divisions and from 0 to 400-inches of water with 200 divisions.
Filter	Used in vacuum line whenever it is possible that gauge under test may contain moisture. Prevents any moisture from entering vacuum test line or vacuum pump. Has no effect on accuracy of test circuit.
Packing Kit Assembly	Contains packings normally required in the use of portable calibration system. Also contained is a tube of approved lubricant.
Quick-Disconnect Probe	Allows master gauges to be quickly connected or disconnected from test circuit.
Dust Cover	Protects quick-disconnect probe when master gauge is not in use.
0 to 30-in. Hg Master Gauge	Reference gauge for calibrating vacuum levels on vacuum gauges and transducers. The gauge is calibrated from 0 to 30-inches of mercury with 600 divisions.

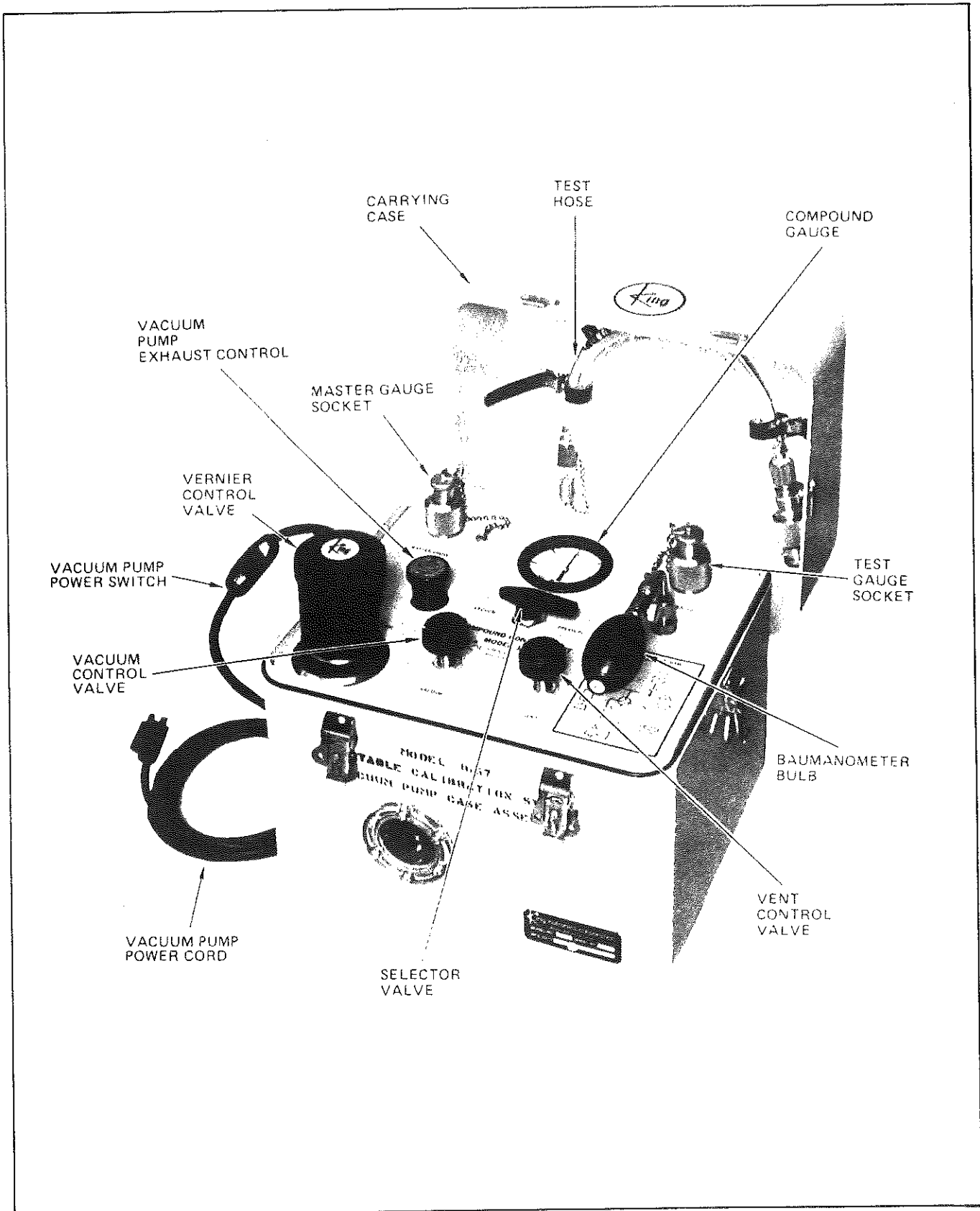

Figure 2-2. Vacuum Pump Case Assembly Controls, Indicators, and Operating Equipment

Table 2-2. Vacuum Pump Case Assembly
Controls, Indicators, and Operating Equipment

CONTROL, INDICATOR, OR EQUIPMENT	OPERATING FUNCTION
MASTER GAUGE Socket	Quick-disconnect socket for master gauge. Connect master gauge into socket during calibration or test operation.
Test Hose	Allows test circuit to be connected to a remote panel mounted gauge. Hose is 10 feet long. A quick-disconnect probe is on one end and a quick-disconnect socket on the other.
Compound Gage	Continuously monitors test circuit. Provides general indication of test pressure or vacuum level in test circuit. Indicates from 0 to 30 inches mercury vacuum and from 0 to 15 psi pressure.
TEST GAUGE Socket	Quick-disconnect socket for test gauge. Connect gauge under test into socket during calibration or test operation. If test gauge is a remote panel gauge, connect test hose to test gauge socket then to test gauge.
Baumanometer Bulb	Used to pump up pressure in test circuit.
VENT Control Valve	Vents test circuit when open. This is a soft seat valve. Use only gentle hand force to prevent damage to valve.
Selector Valve	Three position valve. In the VACUUM position the test circuit is connected to the vacuum pump. In the PRESSURE position the test circuit is connected to the baumanometer bulb. In the OFF position the test circuit is isolated from both the vacuum pump and baumanometer.
Vacuum Pump Power Cord	Connect to standard 115 V ac, 60 Hz power outlet to provide power for the vacuum pump.
Vacuum Pump Power Switch	Connect or disconnect power to vacuum pump.
VACUUM Control Valve	Meters vacuum from pump to test circuit. Operate vacuum pump and operate valve slightly until desired vacuum is in test circuit. This is a soft seat valve. Use only gentle hand force to prevent damage to valve.
VERNIER CONTROL Valve	Provides fine control of pressure level in test circuit. Clockwise rotation increases pressure or decreases vacuum (lower reading). Counter-clockwise rotation decreases pressure or increases vacuum (higher reading).
VACUUM PUMP EXHAUST Control	Open during vacuum pump operation to allow venting of vacuum pump. Close when transporting case assembly to prevent loss of vacuum pump oil.

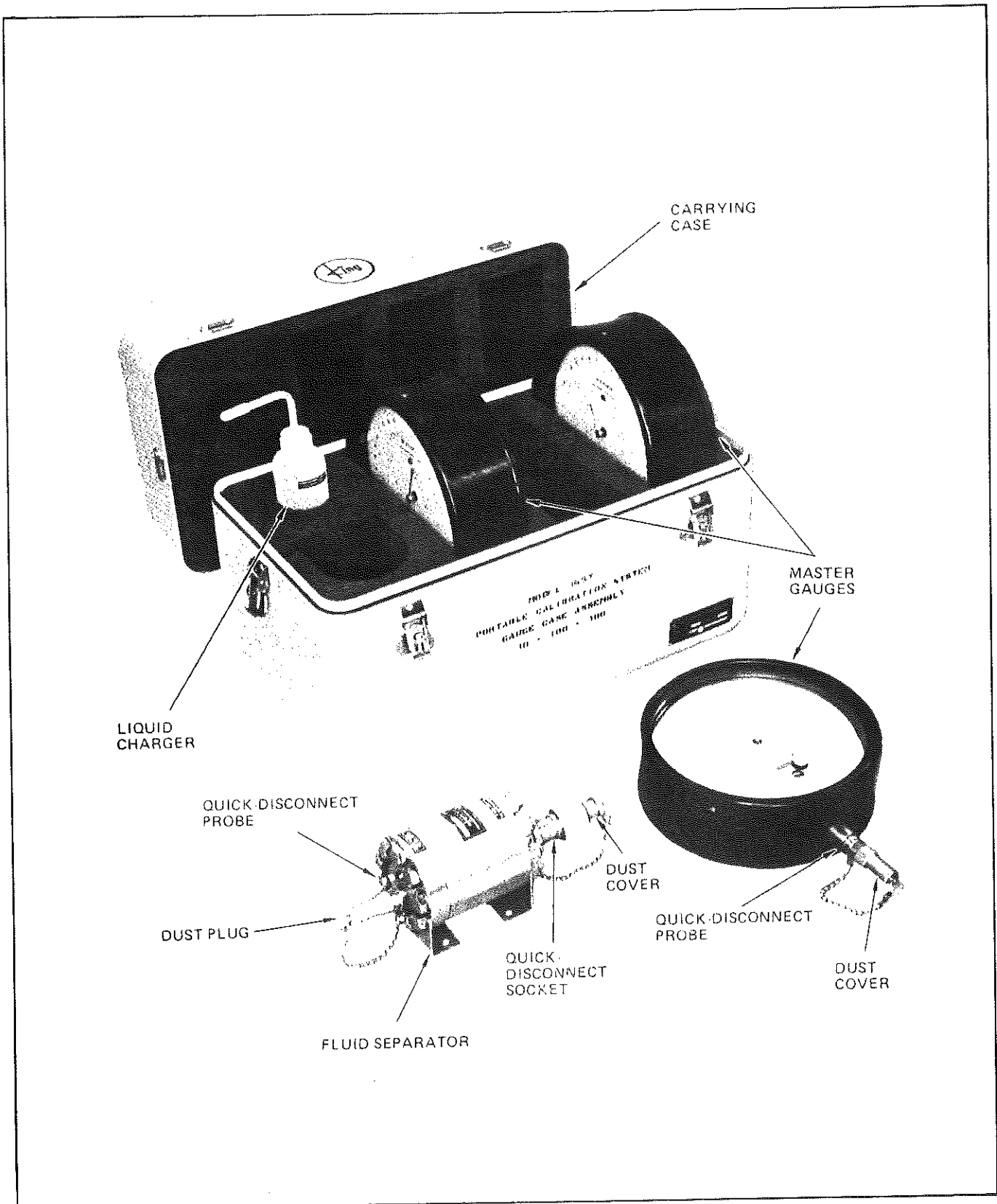

Figure 2-3. 30, 100, and 300 Psig Gauge Case Assembly and 1000, 3000, and 10,000 Psig Gauge Case Assembly Indicators and Operating Equipment

Table 2-3. 30, 100, and 300 Psig Gauge Case Assembly and 1000, 3000, and 10,000 Psig Gauge Case Assembly Indicators and Operating Equipment

CONTROL, INDICATOR, OR EQUIPMENT	OPERATING FUNCTION
Liquid Charger	Plastic bottle used to charge the fluid separator with operating fluid required to operate the gauge under test. One liquid charger is filled with hydraulic fluid and the other is filled with compressor oil.
Master Gauges	Reference gauges for calibrating pressure gauges, transducers and other pressure sensitive devices. One gauge is calibrated from 0 to 30 psig with 600 divisions. Another is calibrated from 0 to 100 psig with 1000 divisions. Another is calibrated from 0 to 300 psig with 600 divisions, another is calibrated from 0 to 1000 psig with 1000 divisions, another is calibrated from 0 to 3000 psig with 600 divisions, and another is calibrated from 0 to 10,000 psig with 1000 divisions.
Quick-Disconnect Probe and Socket	Allows master gauges and fluid separator to be quickly connected or disconnected from test circuit.
Dust Cover	Protects quick-disconnect probes and sockets when gauge or fluid separator are not in use.
Fluid Separator	Used when gauge under test cannot be connected directly to test circuit (contains distilled water). Thus if the gauge under test requires hydraulic fluid or compressor oil the appropriate fluid separator must be used.

Table 2-4. Hand Pump Case Assembly Controls and Equipment

CONTROL, INDICATOR, OR EQUIPMENT	OPERATING FUNCTION
High Pressure Hoses	Allows test circuit to be connected to a remote panel mounted gauge. One hose is 5 feet long and the second is 10 feet long. A quick-disconnect probe is on one end and a quick-disconnect socket on the other.
Adapter Kit	Provides adapters, tubes, and probes normally needed to connect gauges under test to test circuit.
Hand Pump	Used to pressurize test circuit. The pump can be operated in a high volume low pressure mode and in a low volume high pressure mode.
Vernier Control Valve	Provides fine control of pressure level in test circuit. Clockwise rotation increases pressure and counterclockwise rotation decreases pressure.

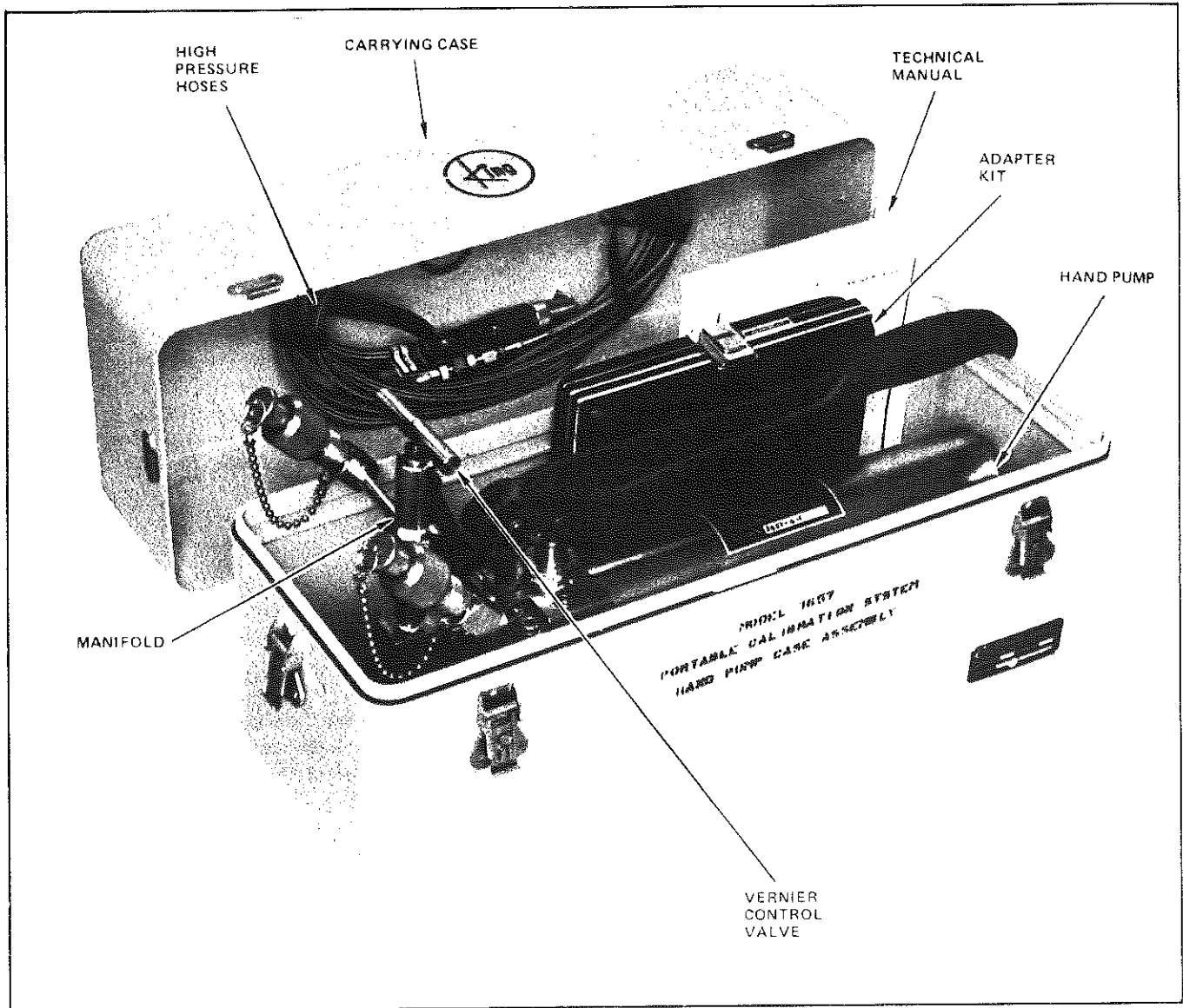

Figure 2-4. Hand Pump Case Assembly Controls and Equipment (Sheet 1 of 2)

Table 2-4. Hand Pump Case Assembly Controls and Equipment (Continued)

CONTROL, INDICATOR, OR EQUIPMENT	OPERATING FUNCTION
Manifold	Provides sockets for master gauge and gauge under test. The manifold is equipped with quick-disconnect sockets to receive the master gauge and test gauge.
Vent Valve	When open, allows pump chamber to vent into reservoir. Rotate valve counterclockwise to open. Rotate clockwise to close. Position of the vent valve handle can be adjusted by closing valve, pulling handle outward, and rotating handle to desired position.

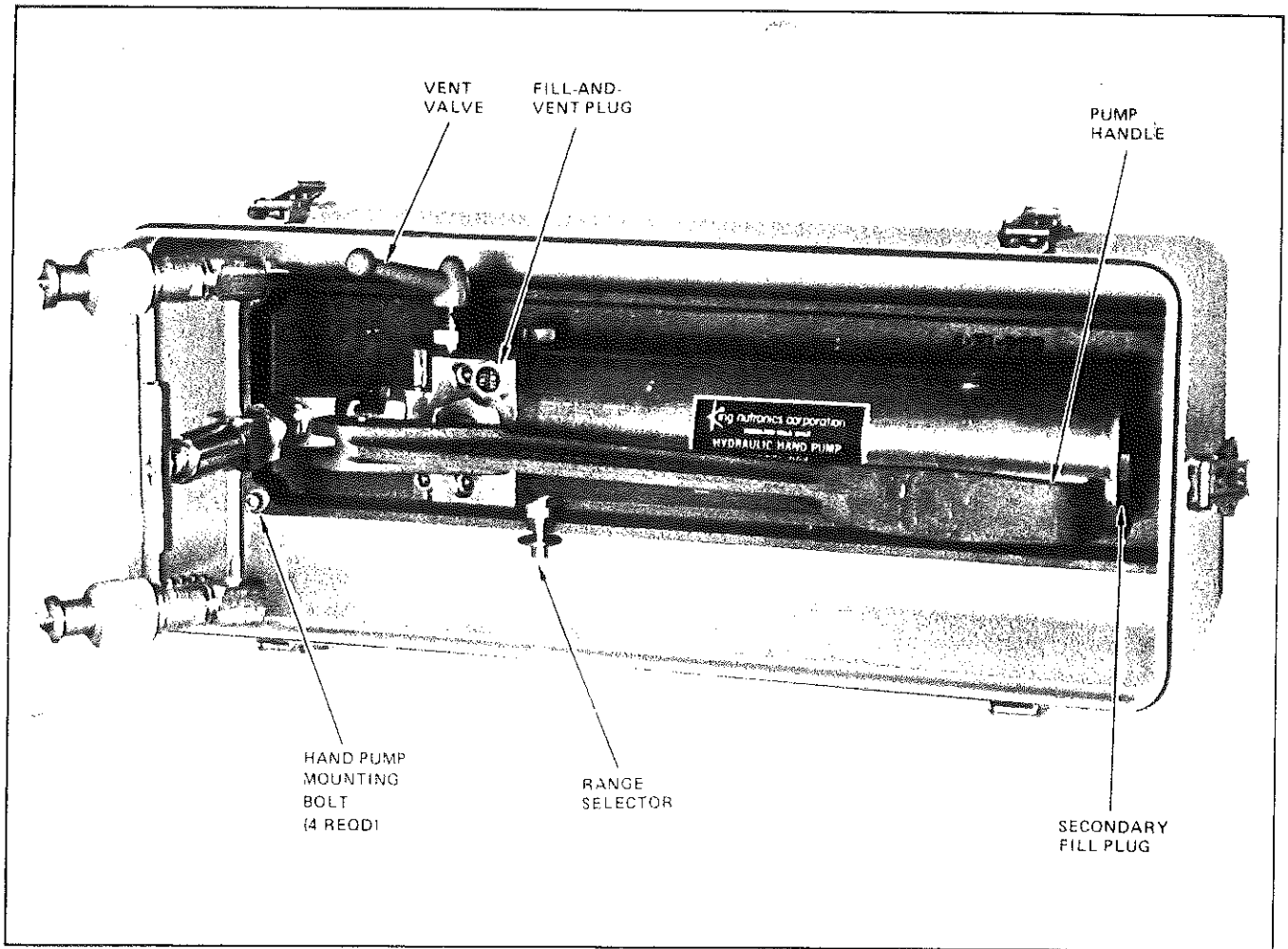

Figure 2-4. Hand Pump Case Assembly Controls and Equipment (Sheet 2 of 2)

Table 2-4. Hand Pump Case Assembly Controls and Equipment (Continued)

CONTROL, INDICATOR, OR EQUIPMENT	OPERATING FUNCTION
FILL and VENT Plug	Provides port for filling and venting pump chamber (must be open during pump operation).
Pump Handle	Operate pump handle to pump up pressure.
Secondary Fill Plug	Provides second fill port which may be more convenient than FILL and VENT port during priming. Pump must be removed from case to gain access.
Range Selector	Sets the pump to high-volume low-pressure when pulled out and sets the pump to low volume high-pressure when pushed in.
Hand Pump Mounting Bolts	Remove four bolts to remove hand pump from case.

2-8. VACUUM PUMP CASE ASSEMBLY OPERATION

2-9. PRE-OPERATING PROCEDURE. Perform the following pre-operating procedure as follows:

1. Unlatch six latches on vacuum pump case assembly and on vacuum and 15 psig gauge case assembly cases and remove case lids.
2. Select desired master gauge from vacuum and 15 psig gauge assembly case and connect to MASTER GAUGE quick-disconnect socket.
3. Set selector valve to OFF, close VACUUM and VENT valves, and set VERNIER CONTROL valve to approximate mid range. Verify that baumanometer bulb thumbscrew valve is closed.

2-10. PRESSURE CALIBRATION OPERATION. To perform calibration on a test gauge from 0 to 15 psig, perform the following operating procedures (see figure 2-5).

1. Perform pre-operating procedure as detailed in paragraph 2-9.
2. Connect test gauge to TEST GAUGE quick-disconnect socket. If test gauge is mounted on a remote panel location, use test hose. If required, use appropriate adapter, tube, and probe from the adapter kit located in the hand pump case assembly.

NOTE

Before proceeding with the calibration the Master Gauge and the Test Gauge should be exercised. If the gauges have identical ranges they can be done simultaneously, otherwise they should be done individually. Slowly pressurize the gauge to full scale indication then vent to zero. Repeat the process twice more. Upon completion ensure the master gauge indicates zero, adjust the "Zero Adjust" as necessary. Rotate the screw clockwise to move the pointer upscale and counterclockwise to move the pointer downscale.

3. Set selector valve to PRESSURE.
4. Manually operate baumanometer bulb until pressure is slightly less than the desired value.
5. Set selector valve to OFF.
6. Rotate VERNIER CONTROL valve clockwise until exact test point pressure is reached.

NOTE

Momentary pressure decay on increasing pressure and momentary pressure rise on decreasing pressure is due to thermal effect. Effect will stabilize rapidly.

7. For decreasing pressure tests, rotate VENT control valve slightly open until pressure is slightly greater than desired value, then rotate VENT control valve to fully closed.

8. Rotate VERNIER CONTROL valve counterclockwise until test point pressure is reached.

9. Repeat steps 7 and 8 as necessary to complete full range of tests.

2-11. VACUUM CALIBRATION OPERATION. To perform calibration on a test gauge from 0 to 30 inches mercury vacuum, perform the following operating procedures (see figure 2-6):

1. Perform pre-operating procedure as detailed in paragraph 2-9.
2. Open VACUUM PUMP EXHAUST control.
3. Connect test gauge to TEST GAUGE quick-disconnect socket. If test gauge is mounted on a remote panel location, use test hose. If required, use appropriate adapter, tube, and probe from the adapter kit located in the hand pump case assembly. If a possibility of moisture within the test gauge exists, install the filter from the vacuum and 15 psig gauge case assembly between the test gauge and TEST GAUGE socket or between the test gauge and test hose for remote panel calibrations.
4. Set selector valve to VACUUM.
5. Connect vacuum pump power cord to 115 V ac, 60 Hz.

NOTE

Before proceeding with the calibration exercise the gauges by operating the vacuum pump until the maximum vacuum level is obtained. Close the vacuum control valve and turn off pump. Check the system for leaks. Repeat gauge exercise twice more. When all vacuum has been relieved to zero check the master gauge to insure it indicates zero. Adjust as necessary to obtain zero indication.

6. Set the vacuum pump power switch to ON and open VACUUM control valve slightly to evacuate test circuit. Carefully manipulate the VACUUM control valve until vacuum is slightly less than the desired value. If more convenient, the exact vacuum level can be obtained by operating the VACUUM control valve.

NOTE

Opening the vacuum control valve too much during initial evacuation will cause a large amount of air to pass through the vacuum pump and oil will be forced out the pump exhaust port.

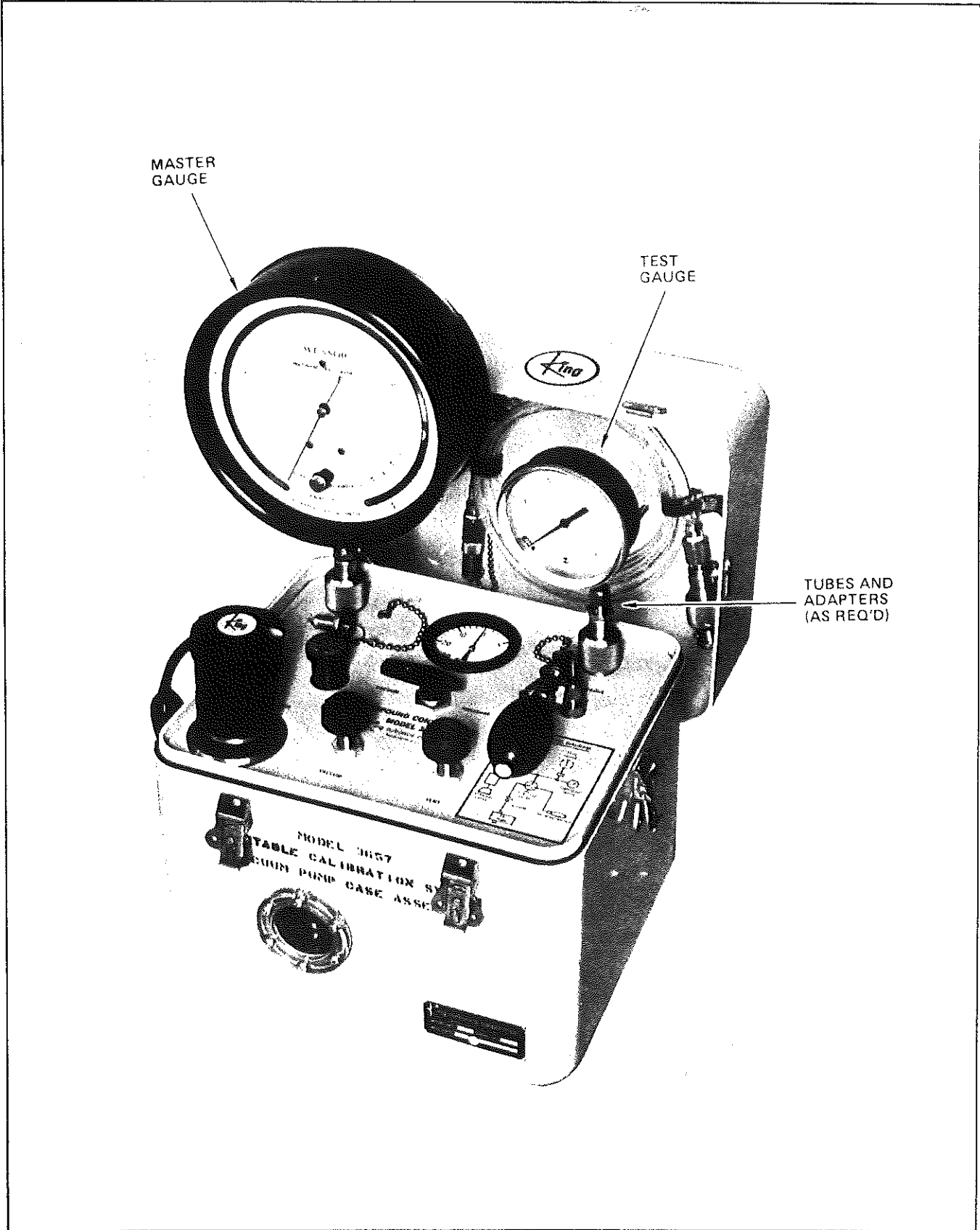

Figure 2-5. Typical Low Pressure Gauge Calibration Set-Up

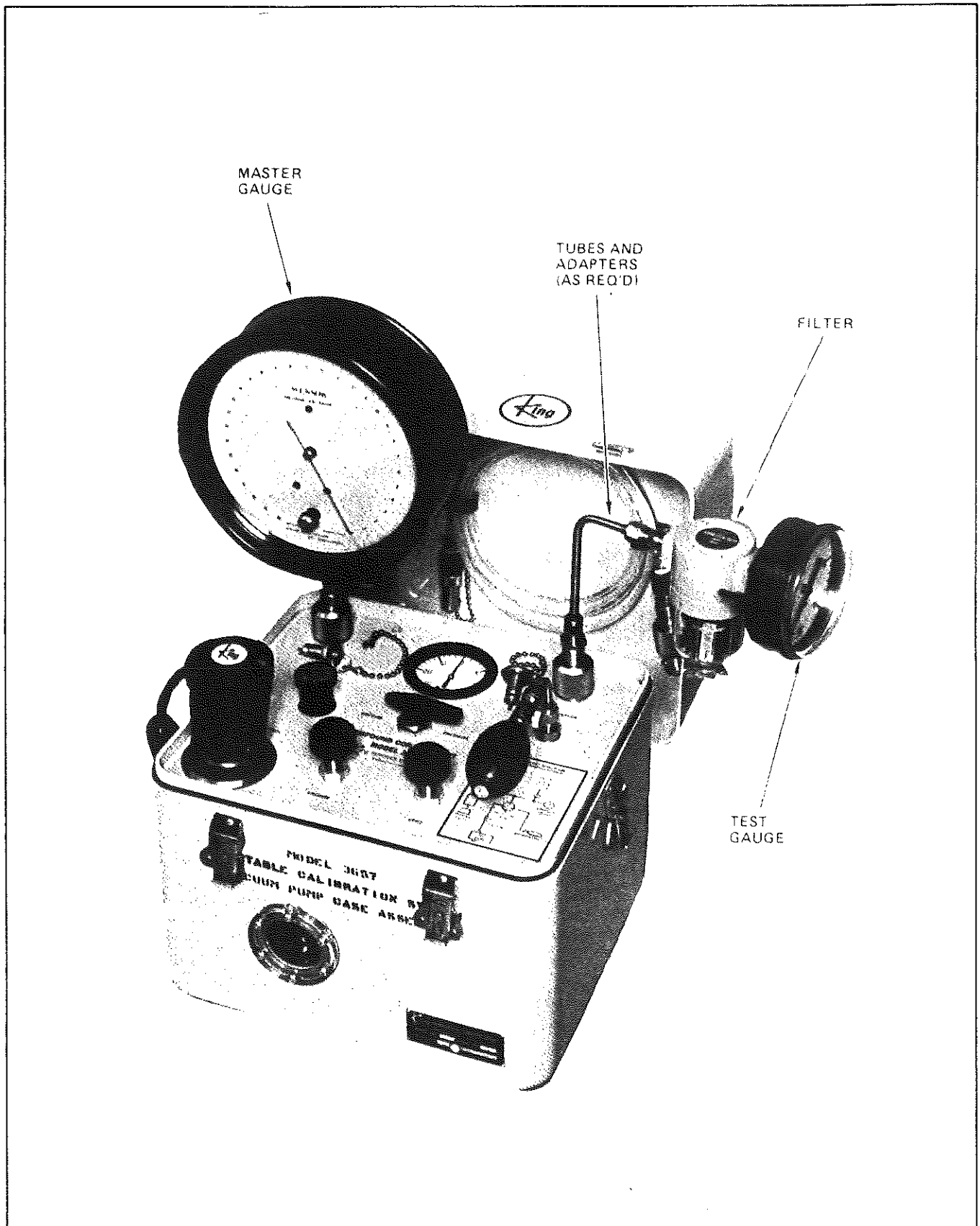

Figure 2-6. Typical Vacuum Gauge Calibration Set-Up

7. Rotate VERNIER CONTROL valve counterclockwise until exact test point vacuum level is obtained.

8. Repeat steps 7 and 8 as necessary to complete full range of tests.

9. For decreasing vacuum level tests, rotate VENT control valve slightly open until vacuum level is slightly greater than desired vacuum level, then rotate VENT control valve to fully closed.

10. Rotate VERNIER CONTROL valve clockwise until exact test point vacuum level is obtained.

11. Repeat steps 10 and 11 as necessary to complete full range of tests.

2-12. POST-OPERATING PROCEDURE. After completion of tests, perform the following post-operating procedures:

1. Open VENT valve until pressure/vacuum level in test circuit is zero.

2. Remove master gauge from test circuit. Install dust cover on master gauge probe and place master gauge into vacuum and 15 psig gauge case assembly.

3. Remove test gauge from test circuit. If test hose, adapter, tube, or probe has been used, remove from test circuit and replace in appropriate storage location.

4. Remove vacuum pump power cord from power and place on top of the vacuum pump case assembly panel.

5. Install dust covers in TEST GAUGE and MASTER GAUGE sockets.

6. Close VACUUM PUMP EXHAUST control.

7. Set selector valve to OFF.

8. If used, clean filter and return to vacuum and 15 psig gauge case assembly.

NOTE

Do not use solvents to clean filter bowl.

9. Place lids on case assemblies and latch in place.

2-13. HAND PUMP CASE ASSEMBLY OPERATION

2-14. PRE-OPERATING PROCEDURE. Perform the following pre-operating procedure as follows:

1. Unlatch six latches on hand pump case assembly and as appropriate for pressure range of test, the 30, 100, 300 psig gauge case assembly, and/or 1,000, 3,000, 10,000 psig gauge case assembly and remove case lids.

2. Before initial use of the hand pump, or if the pump runs dry, fill and prime the pump in accordance with paragraph 2-15.

3. Before initial use of the reference gauges, fill and bleed the Bourdon tubes of each gauge in accordance with paragraph 2-16.

4. To fill and bleed pump manifold assembly, install two probes from adapter kit into manifold quick-disconnect sockets. With hand pump range selector pulled out to high-volume low-pressure position, operate hand pump until distilled water runs out of probe. Remove probe and return them to the adapter kit.

5. Select desired master gauge from one of the gauge case assemblies and connect to master gauge quick-disconnect socket on the hand pump manifold.

2-15. FILLING AND PRIMING HAND PUMP. Before initial use of the hand pump, or if the pump runs dry, fill and prime the pump in accordance with the following instructions (see figure 2-4):



Do not operate hand pump without distilled water in the reservoir. If the pump is operated dry, permanent damage to piston seals will result.

1. Remove fill-and-vent plug. If desired for faster filling, the hand pump can be removed from the case by removing four mounting bolts. After removing hand pump from the case, stand hand pump on end and use secondary fill plug.

2. Fill pump reservoir with distilled water until water is at level of fill-and-vent plug port. If filling through secondary fill port, fill to approximately 1-1/2 inches from top. After filling, install fill-and-vent plug and leave open two turns.

3. Install 0 to 10,000 psig master gauge in one port of the hand pump manifold assembly.

4. Pull out range selector to high-volume, low-pressure position.

5. Open vent valve by placing vent valve handle fully toward reservoir end of pump.

6. Operate pump handle for approximately ten full strokes.

NOTE

When priming pump, always use full strokes of the pump handle. Never use partial or short strokes.

7. Close vent valve by rotating vent valve handle clockwise until tight.

8. Operate pump handle while observing pressure gauge to make certain that pump is operating in high-volume, low-pressure mode and that the pump is holding pressure.

9. When resistance is felt in the pumping action (approximately 400 psig) push in the range selector to low-volume, high pressure position. Operate the pump handle to increase pressure on the gauge.

10. If pressure indicated on gauge fails to increase, or increases slightly, repeat steps 4 through 9 to bleed entrapped air.

11. Open vent valve to relieve pressure in manifold.

12. Disconnect pressure gauge from pump manifold.

2-16. FILLING MASTER GAUGES. Before initial use of the master gauges, fill and bleed the Bourdon tubes of each gauge with distilled water in accordance with the following instructions (see figure 2-7):

1. Remove fill-and-vent plug from hand pump. If necessary, add distilled water to hand pump until water is at level of fill-and-vent plug port. After filling, install fill-and-vent plug and tighten plug then open two turns.

CAUTION

If pump requires a large amount of distilled water, indicating that the reservoir is dry, perform the filling and priming procedures described in paragraph 2-15. Pump will not build up, or hold, pressure until all air has been bled from low-volume, high-pressure area. Do not operate hand pump without water in the reservoir. If the pump is operated dry, permanent damage to piston seals will result.

2. Remove dust cover from master gauge quick-disconnect probe and install master gauge on hand pump manifold assembly.

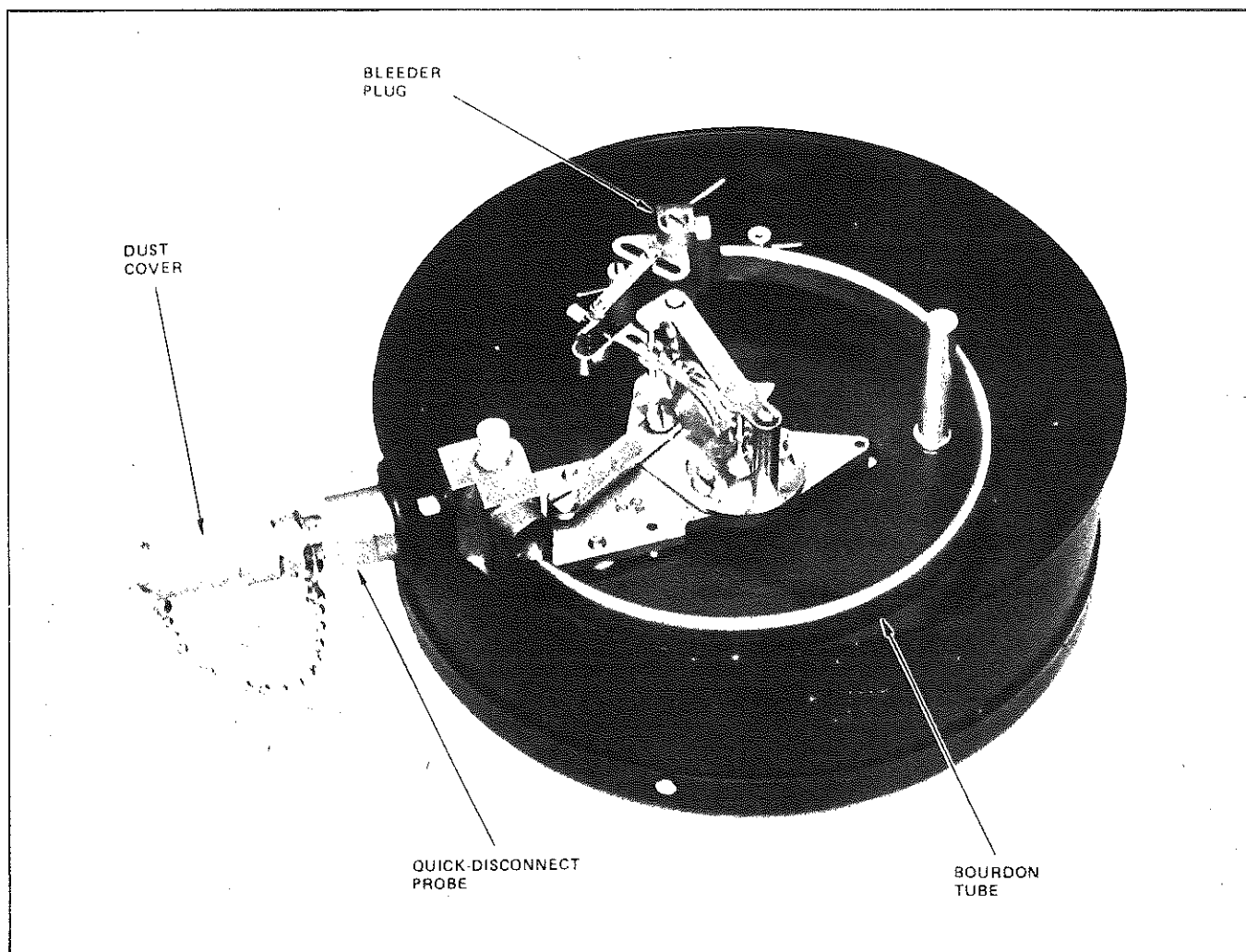

Figure 2-7. Filling Master Gauges

3. Remove master gauge back plate by unscrewing captive screw.
4. While holding the Bourdon tube with one hand, loosen the bleeder plug approximately one to two turns.
5. Pull out range selector of the hand pump to operate pump in high-volume, low-pressure mode.

CAUTION

To prevent damage to Bourdon tube, restrain tube with one hand while tightening bleeder plug. The bleeder plug has a packing seal and should not be overtightened.

6. Operate pump handle to establish a flow of distilled water through the master gauge Bourdon tube. When the stream of water emerging from the tube is free of all evidence of air bubbles, tighten the bleeder plug.

7. Install the gauge back plate and place the filled and bled master gauge in the gauge case assembly.

2-17. HIGH PRESSURE CALIBRATION OPERATION.
To perform calibration on a test gauge, perform the following procedures (see figure 2-8):

1. Perform pre-operating procedure as detailed in paragraph 2-14.

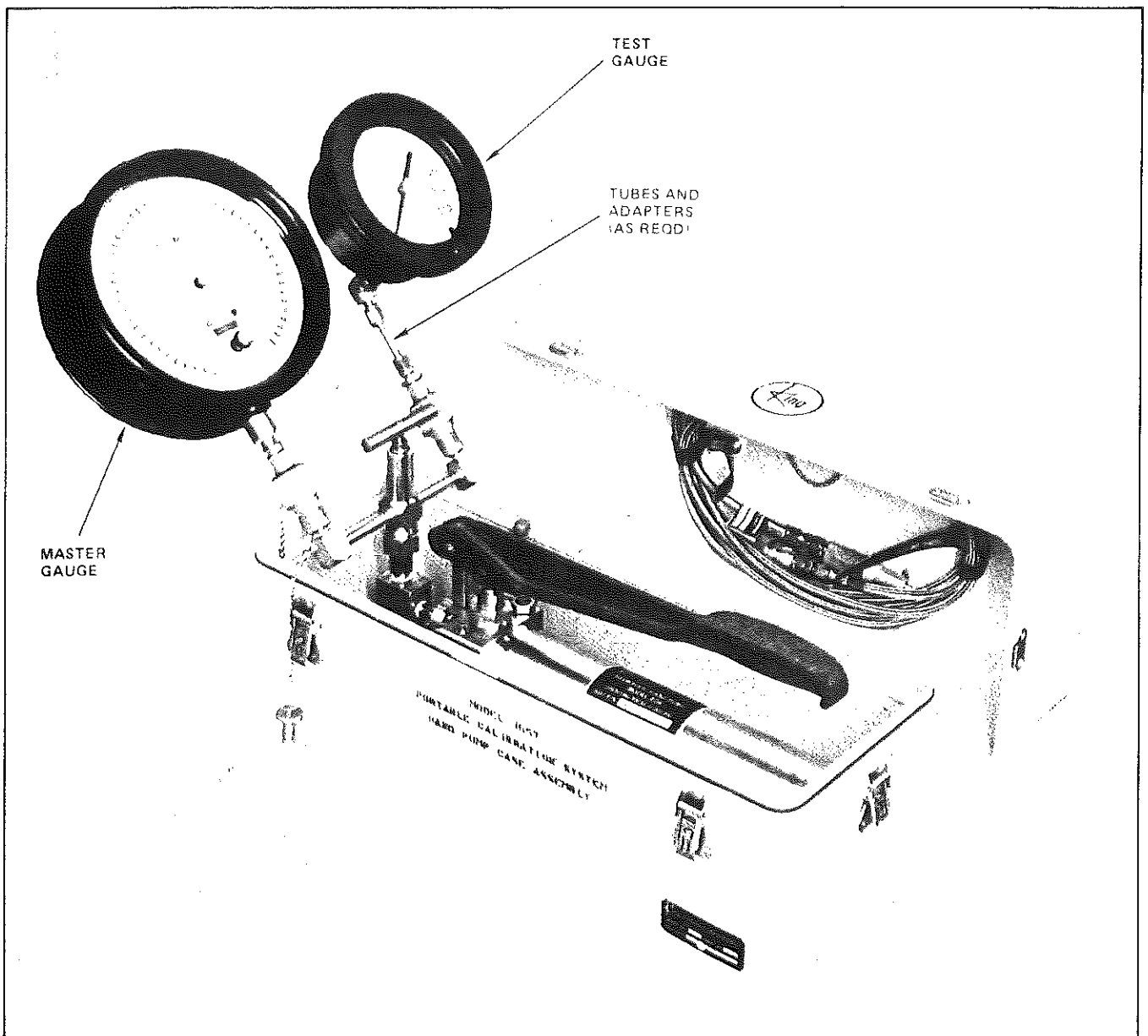

Figure 2-8. Typical High Pressure Gauge Calibration Set-Up

2. Unscrew FILL and VENT plug two turns to vent pump.



Failure to open FILL and VENT plug before operating pump may result in loss of priming. If this occurs, perform the filling and priming procedures detailed in paragraph 2-15.

3. Fill gauge under test with appropriate fluid (water, hydraulic fluid, or compressor oil). If hydraulic fluid or compressor oil is used, the appropriate fluid separator must be used. Install test gauge into other quick-disconnect socket on the manifold assembly. If required, use appropriate adapter, tube, and probe from the adapter kit. If a panel-mounted gauge is to be tested, connect high-pressure hose to manifold assembly and bleed air by pumping distilled water through hose. Connect hose to test gauge.

NOTE

If a hydraulic oil or compressor oil system gauge is to be calibrated, install fluid separator in the test circuit. Remove fill plug (6, figure 7-12) from gauge side of separator. Using the appropriate liquid charger, force diaphragm of separator to pump side by filling gauge side of separator with hydraulic oil or compressor oil. Keep spout of liquid charger firmly pressed in fill port to prevent spillage. After filling, install and tighten fill plug.

4. Pull out range selector to high-volume low-pressure position.

5. Rotate vent valve handle fully clockwise to close vent valve.

NOTE

Bleed air from test gauge and line downstream of pump discharge port by opening line at highest possible point.

The quick-disconnect couplings are automatically locked together when pressures are in excess of 250 psig. The couplings will automatically unlock after pressure falls below 150 psig, allowing the couplings to be separated manually.

6. Operate pump handle until pressure is indicated on test gauge. Continue using high-volume low-pressure range on hand pump as long as practical. Generally on measurements of less than 400 psig, the low-volume high-pressure range is not required.



Master gauges are not equipped with relief valves. Although master gauges can tolerate over pressure up to 150 percent without damage, excessive pressure may cause calibration shift and pressures in excess of limits may cause permanent damage.

7. If pressures in excess of 400 psig are required, push range selector in to low-volume high-pressure position, then continue to operate pump handle until desired pressure is obtained.

8. For exact settings, operate pump handle until test pressure is slightly below the desired value, and lightly tap gauge.

9. Rotate the vernier control valve clockwise until the exact test point pressure is reached.

10. Repeat steps 6 through 9 as necessary to complete full range of tests.

11. For decreasing pressure tests, rotate vent valve handle slowly counterclockwise until pressure is slightly greater than desired value. then rotate vent valve handle fully clockwise.

12. Rotate the vernier control valve counterclockwise until the exact test point pressure is reached, and lightly tap gauge.

13. Repeat steps 11 and 12 as necessary to complete full range of tests.

2-18. POST-OPERATING PROCEDURE. After completion of tests, perform the following post-operating procedures:

1. Rotate vent valve handle fully counterclockwise until pressure in test circuit is zero.

2. Remove master gauge from manifold quick-disconnect socket. Install dust cover on master gauge probe and place master gauge into gauge case assembly.

NOTE

The quick-disconnect couplings are automatically locked together when pressures are in excess of 250 psig. The couplings will automatically unlock after pressure falls below 150 psig, allowing the couplings to be separated manually.

3. Remove test gauge from test circuit. If a test hose, adapter, tube, or probe has been used, remove from test circuit and replace in appropriate storage location.

4. If used, clean fluid separator and return to storage location.

5. Install dust plugs in manifold assembly quick-disconnect sockets. Rotate vent valve handle fully counterclockwise to open valve and vent any pressure in pump. Tighten FILL and VENT plug.

6. Place lids on case assemblies and latch in place.

CHAPTER 3

FUNCTIONAL DESCRIPTION

3-1. MAJOR SUBASSEMBLIES

3-2. The portable calibration system consists of a vacuum and 15 psig gauge case assembly; a vacuum pump case assembly; a 30, 100, and 300 psig gauge case assembly; a 1000, 3000, and 10,000 psig gauge case assembly; and a hand pump case assembly (see figure 1-1).

3-3. MASTER GAUGES. The master gauges contained in the gauge case assemblies utilize a Bourdon tube to determine pressure. When pressure is applied to the interior of the Bourdon tube pressure is applied to the sides of the tube. Since the outer tube surface is slightly larger in length than the inner tube surface more force is exerted on the outer surface and the tube tends to straighten. The slight movement is transferred to the gauge dial by a series of gears and linkage. The Bourdon tube material provides temperature compensation and adjustments are provided to allow accurate calibration. Each gauge is equipped with a quick-disconnect probe which mates with the quick-disconnect sockets used throughout the portable calibration system.

3-4. FLUID SEPARATORS. Two fluid separators are provided with the portable calibration system. The separators are used for calibration of test gauges requiring hydraulic oil or compressor oil. The separators prevent mixing of the oil in the test gauge with the water in the hand pump. Each separator is identical except one contains hydraulic oil and the other contains compressor oil. The separators have two chambers separated by a rubber diaphragm. Oil is contained in the chamber on the test gauge side and distilled water on the hand pump side. The rubber diaphragm allows pressure to be transferred from the water to the oil without mixing the fluids. The test gauge side of the separator is equipped with a quick-disconnect socket and the hand pump side of the separator is equipped with quick-disconnect probe.

3-5. HAND PUMP. The hand pump is designed for use in applications requiring pressures up to 10,000 psig at comparative low fluid volumes. The hand pump consists of a manually operated pump bolted to a drip pan. The pump is a dual volume design based on the use of a double diameter piston and provides low pressure outputs at relatively high volume, or high pressure outputs at relative low volume. The mode of operation is determined by the position of a range selector valve installed in one side of the pump body. When the selector is pulled out, the full diameter of the piston is used to obtain large volume flows at low pressures. When the selector valve is pushed in, the smaller net piston diameter provides low volume flows at high pressures. A manually operated vent valve is installed in the pump body on the side opposite to the range selector. For convenience, the rotational position of the vent valve handle is adjustable without the use of tools.

3-6. VERNIER CONTROL VALVE ASSEMBLY. The vacuum pump case assembly and the hand pump utilize vernier control valves to obtain precise adjustment of static pressures in the test circuits. Although the configuration of each vernier control valve differ somewhat from one another, the operation is identical. A precision leadscrew is used to position an internal piston, which alters the total volume of the test circuit. Rotating the valve handle clockwise decreases the volume within the test circuit, thus increases the pressure. Rotating the valve handle counterclockwise increases the volume within the test circuit, thus decreases the pressure.

3-7. VACUUM PUMP. The vacuum pump is an electrically operated direct drive rotary pump. The pump consists of a rotating concentric rotor containing two metal vanes, mounted eccentrically in a stage ring. The rotor is mounted directed on the motor shaft. Like most vacuum pumps, fresh pump oil maintained at the proper level is required for proper operation and lubrication of the pump. An oil sight gauge is provided for checking oil level.

CHAPTER 4

SCHEDULED MAINTENANCE

4-1. INTRODUCTION

4-2. The scheduled maintenance instructions in this manual are cancelled when the Planned Maintenance System (PMS) is implemented for this equipment aboard your ship or station.

4-3. SCHEDULED MAINTENANCE ACTION INDEX

4-4. Table 4-1 is the scheduled maintenance action index for the portable calibration system.

Table 4-1. Scheduled Maintenance Action Index

PERIODICITY	MAINTENANCE ACTION	REFERENCE
Weekly	Clean equipment	Paragraph 4-6
Semimonthly	Visually check equipment	Paragraph 4-7
Monthly	Visually check pump oil	Paragraph 4-8
Semiannually	Flush vacuum pump oil	Paragraph 4-9

4-5. PREVENTIVE MAINTENANCE PROCEDURES

4-6. **CLEANING.** Perform cleaning of the portable calibration system as follows:

1. Clean external surfaces of case assemblies, gauges, hoses, panels, pump, liquid chargers, fluid separators, and adapter kit case with a clean cloth slightly dampened with clean water as required.

2. Clean all parts resisting cleaning with water with Freon 113, or equivalent.

3. Dry all parts thoroughly with compressed air at low pressure.

4-7. **VISUAL CHECKS.** Visually check the portable calibration system as follows:

1. Check security of mounting of all parts.

2. Check for visual evidence of damage.

3. Check contents of case assemblies, adapter kit, and packing kit assembly for completeness.

4. Check all probes for damage to tips.

5. Inspect hose assemblies for cut or cracked tubes and for security of quick-disconnect couplings.

6. Check master gauges for cracked or broken lenses or other evidence of damage.

7. Check electric cord of vacuum pump for cracked or deteriorated insulation, for bent or broken prongs, and for proper operation of on-off switch.

8. Check oil level of vacuum pump by observation through sight gauge in front of vacuum pump case assembly.

4-8. **VACUUM PUMP OIL LEVEL.** Check vacuum pump oil level as follows:

1. Operate pump for approximately five minutes to warm oil to normal operating level.

2. Turn off vacuum pump and wait for approximately one minute.

3. Using a flash light or lamp visually check oil level through sight gauge located in the front of the vacuum pump case assembly.

4. Oil level shall be visible in sight gauges. If necessary, add DuoSeal oil (or equivalent) to bring oil to proper level. Take care not to overfill oil. Oil can be added through spout (43, figure 7-2) by removing plug (41).

4-9. **VACUUM PUMP OIL FLUSHING.** Whenever vacuum pump oil is contaminated or every six months, flush the vacuum pump oil as follows:

1. Operate vacuum pump for approximately five minutes to warm oil to normal operating level. If oil is extremely contaminated do not operate.

2. Remove chassis assembly (2, figure 7-2) as described in paragraph 6-9.

3. Remove pump assembly (36 thru 53) from case assembly (54) as described in paragraph 6-27.

4. Remove drain plug from pump assembly and drain oil.

5. Install drain plug and add approximately two ounces of DuoSeal oil (or equivalent) through the spout. Operate vacuum pump for approximately one minute.

6. Remove drain plug from pump assembly and drain oil.

7. Repeat steps 5 and 6 as necessary until flushing oil shows no sign of contamination.

8. Install pump assembly into case assembly as described in paragraph 6-65.

9. Install chassis assembly as described in paragraph 6-80.

4-10. SCHEDULED PERFORMANCE TESTS

4-11. No scheduled performance tests are required of the portable calibration system.

CHAPTER 5

TROUBLESHOOTING

5-1. INTRODUCTION

5-2. Troubleshooting of the portable calibration system is accomplished while operating the equipment during normal service.

5-3. TROUBLESHOOTING

5-4. The cause of most troubles occurring with the portable calibration equipment will be obvious. Observe symptoms, refer to the fault logic diagrams, figure 5-1 through 5-5, as appropriate. Repair or replace defective components as required. Refer to table 5-1 for an index of possible troubles referenced to the appropriate fault logic diagrams.

Table 5-1. Troubleshooting Index

TROUBLE	REFERENCE
Vacuum pump fails to start.	Figure 5-1 (A)
Vacuum pump is noisy, inefficient, or fails to draw a vacuum, or hold a vacuum.	Figure 5-1 (B)
Vacuum pump shuts down during operation.	Figure 5-1 (C)
Fluid leaks between body and head on fluid separator.	Figure 5-2 (A)
Inadequate volume displacement with fluid separator.	Figure 5-2 (B)
External leakage on fluid separator.	Figure 5-2 (C)
No flow through high pressure hose or test hose.	Figure 5-3 (A)
External leakage on high pressure hose or test hose.	Figure 5-3 (B)
Master gauge will not zero.	Figure 5-4 (A)
Master gauge does not hold pressure.	Figure 5-4 (B)
Improper high-pressure, low-volume mode with hand pump.	Figure 5-5 (A)
External leakage on hand pump.	Figure 5-5 (B)
Gauge cannot be installed in hand pump manifold coupling.	Figure 5-5 (C)
Gauge cannot be removed from hand pump manifold coupling.	Figure 5-5 (D)

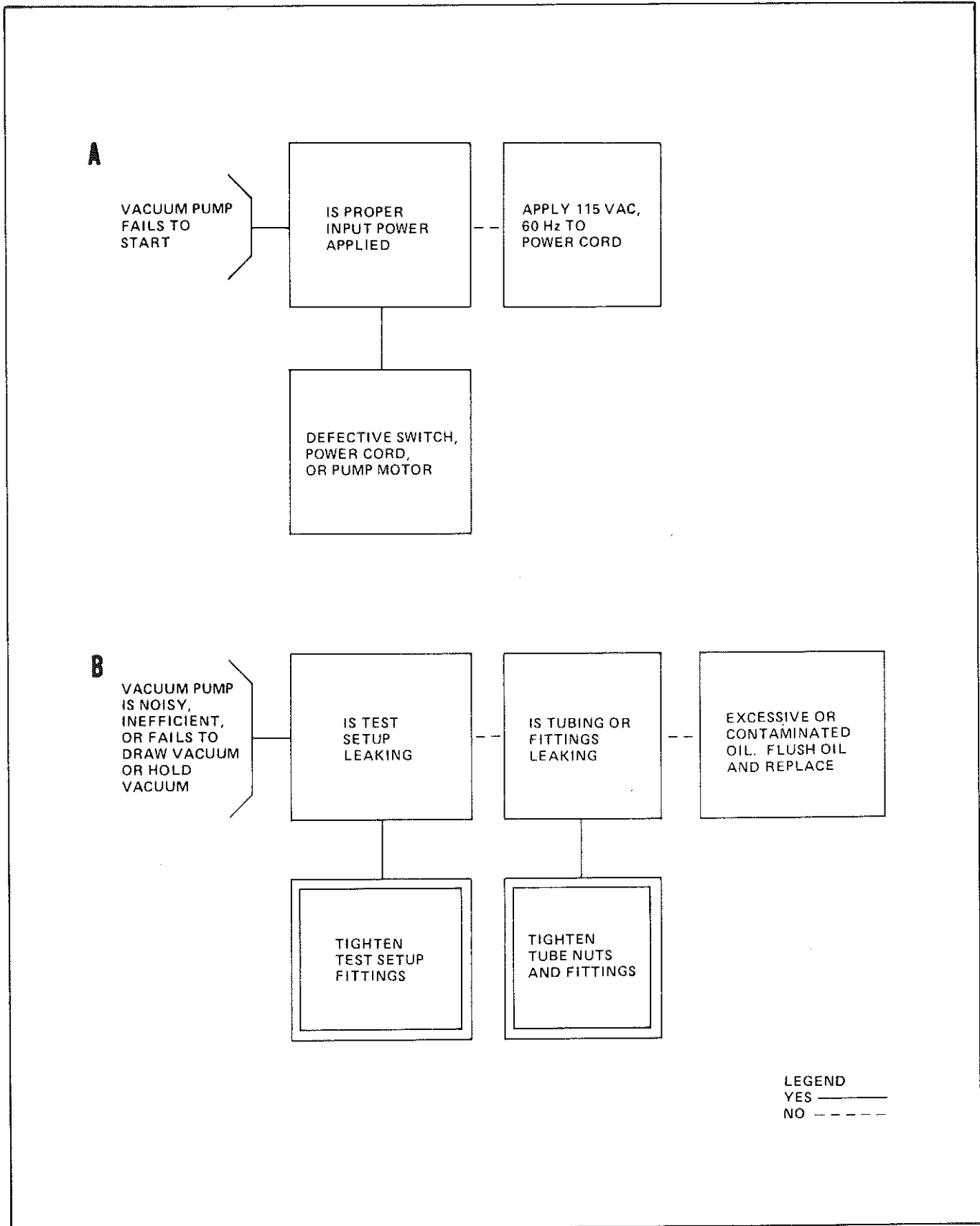

Figure 5-1. Vacuum Pump Case Fault Logic Diagram (Sheet 1 of 2)

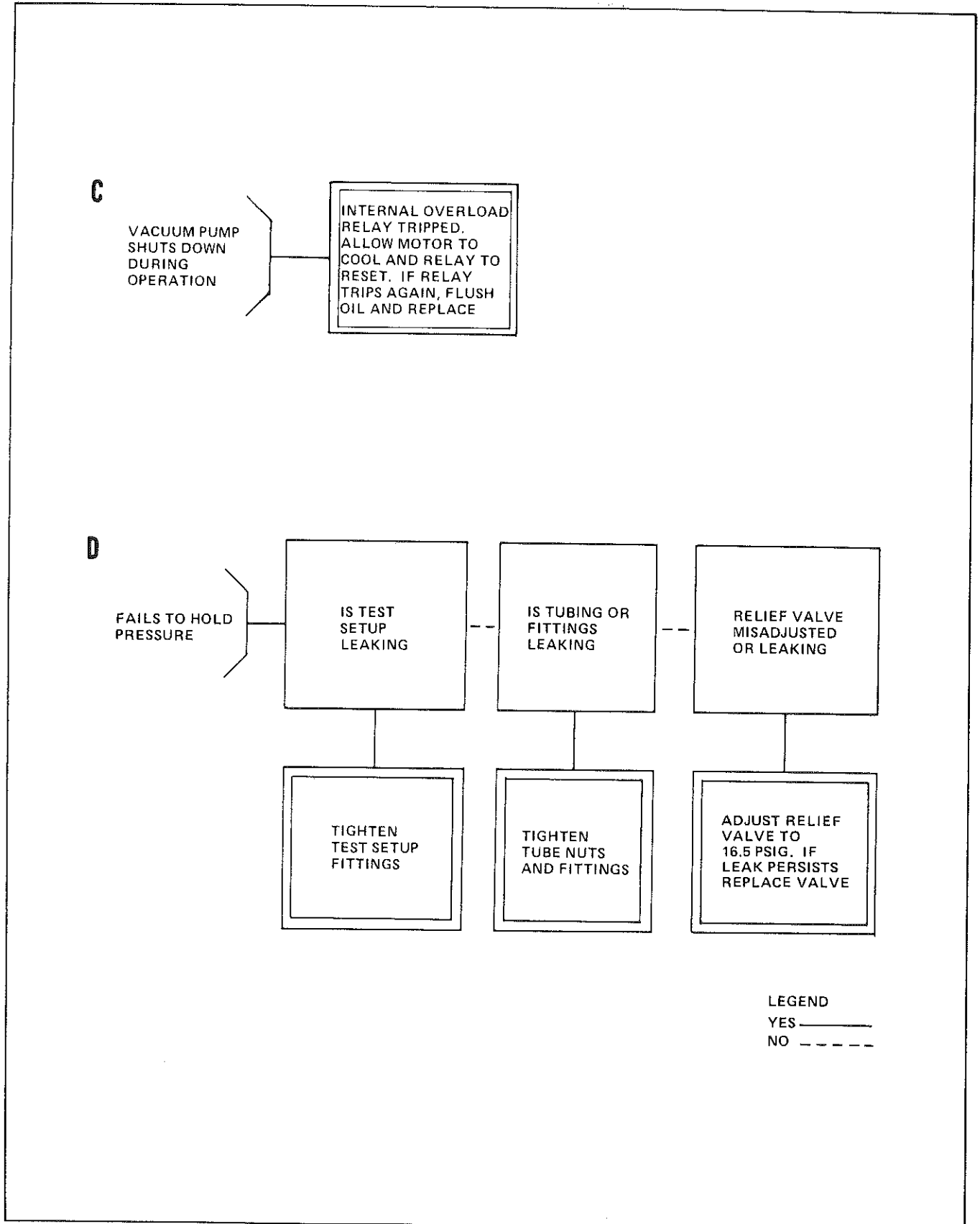

Figure 5-1. Vacuum Pump Case Fault Logic Diagram (Sheet 2 of 2)

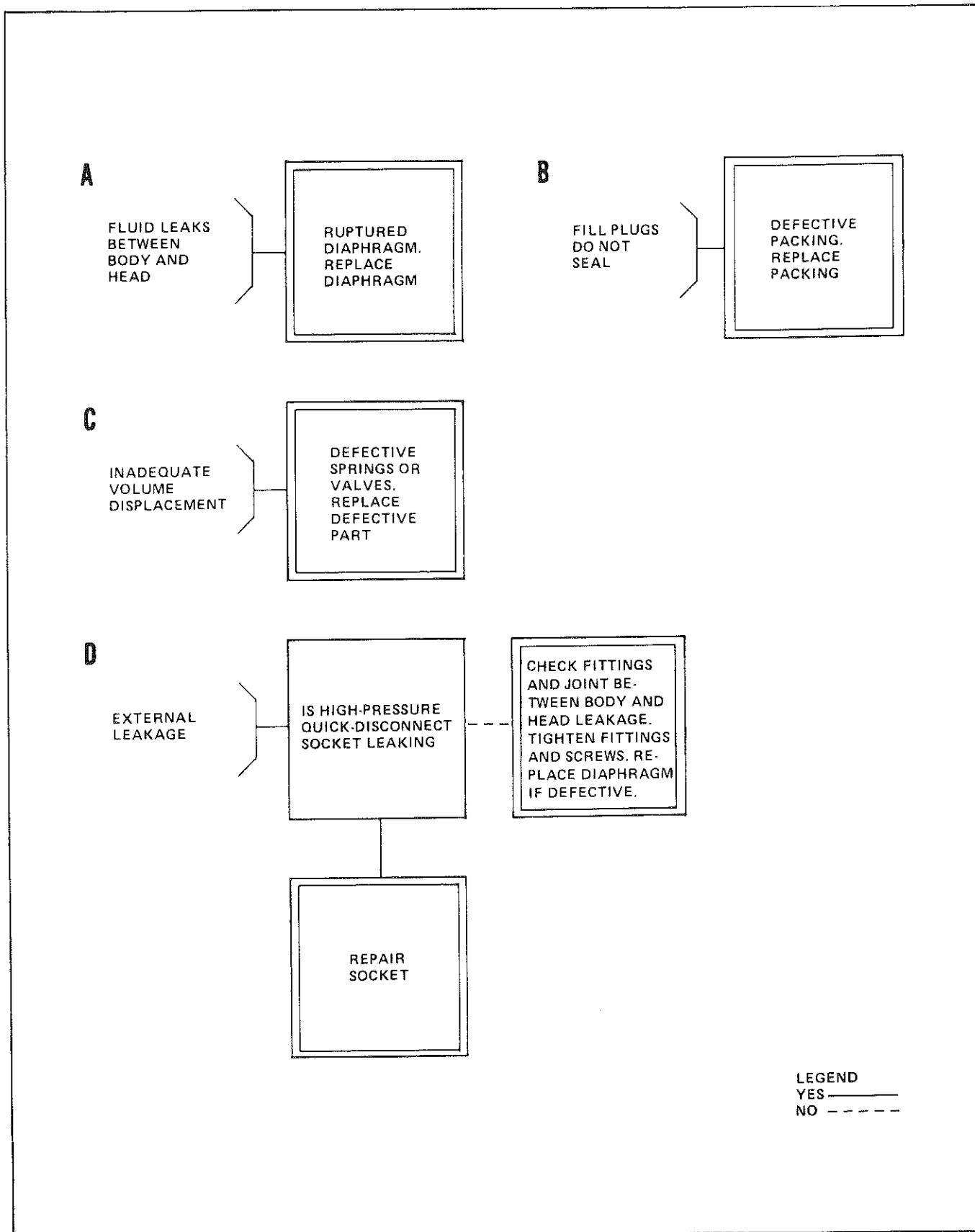

Figure 5-2. Fluid Separator Fault Logic Diagram

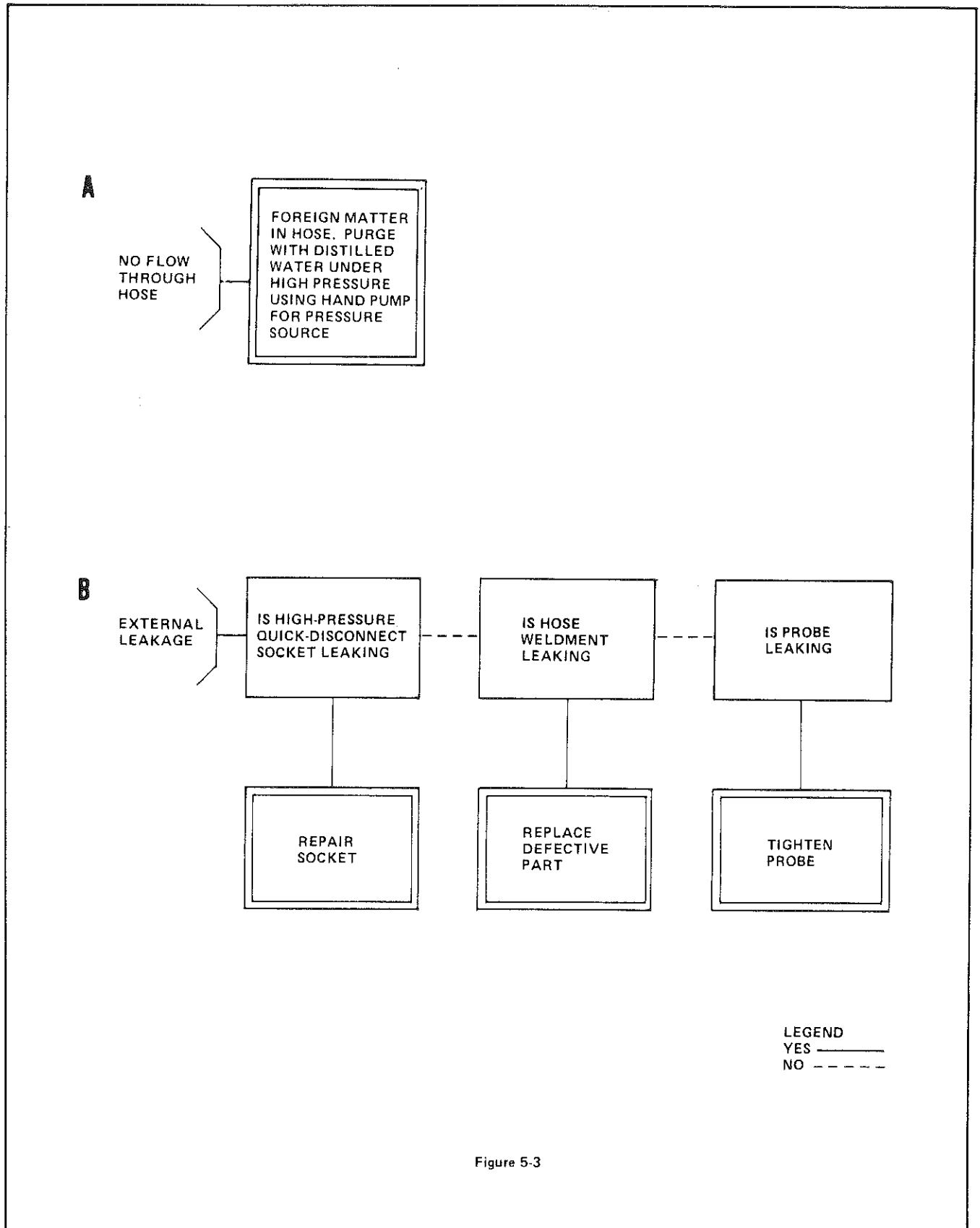

Figure 5-3

Figure 5-3. High Pressure Hose and Test Hose Fault Logic Diagram

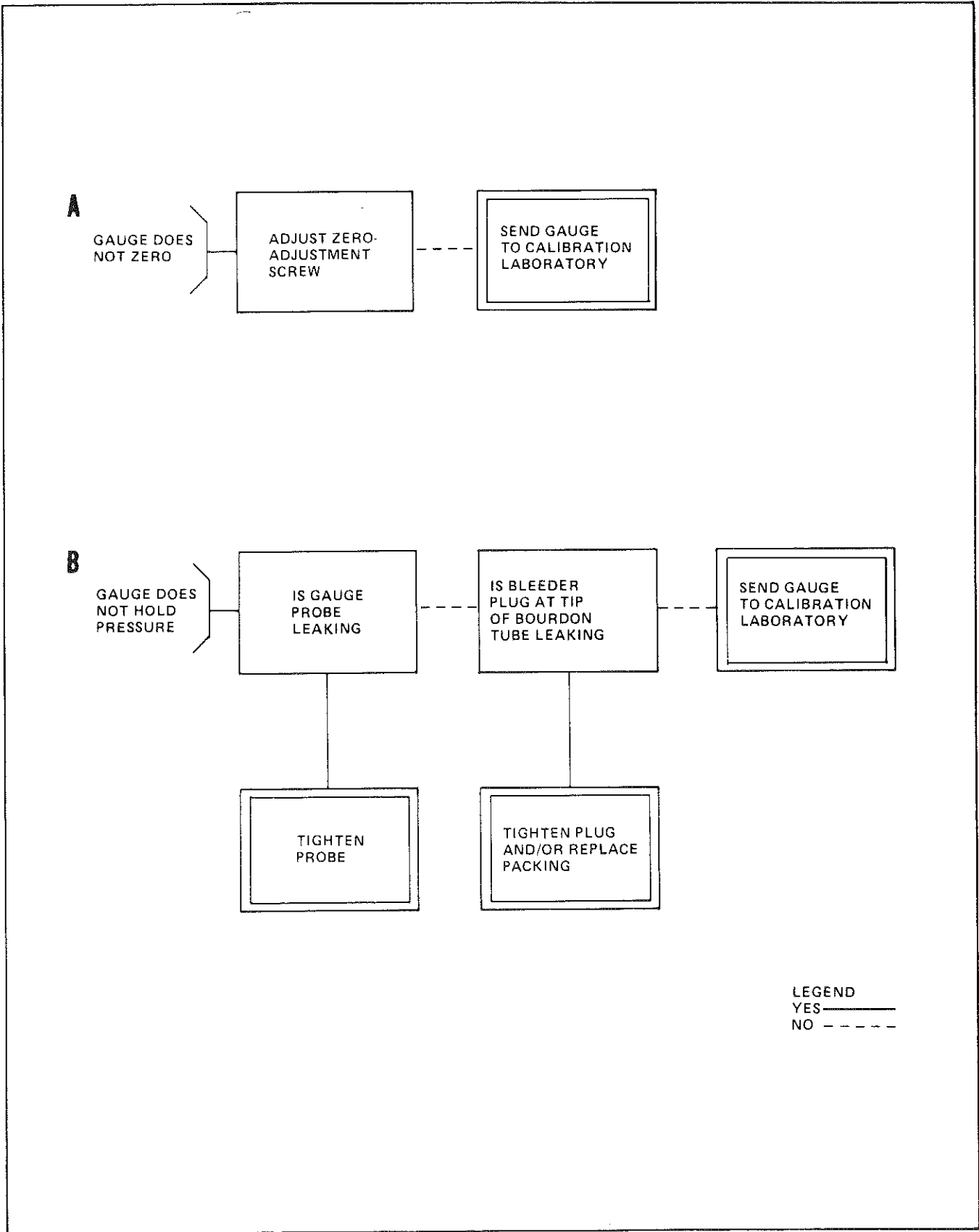

Figure 5-4. Master Gauge Fault Logic Diagram

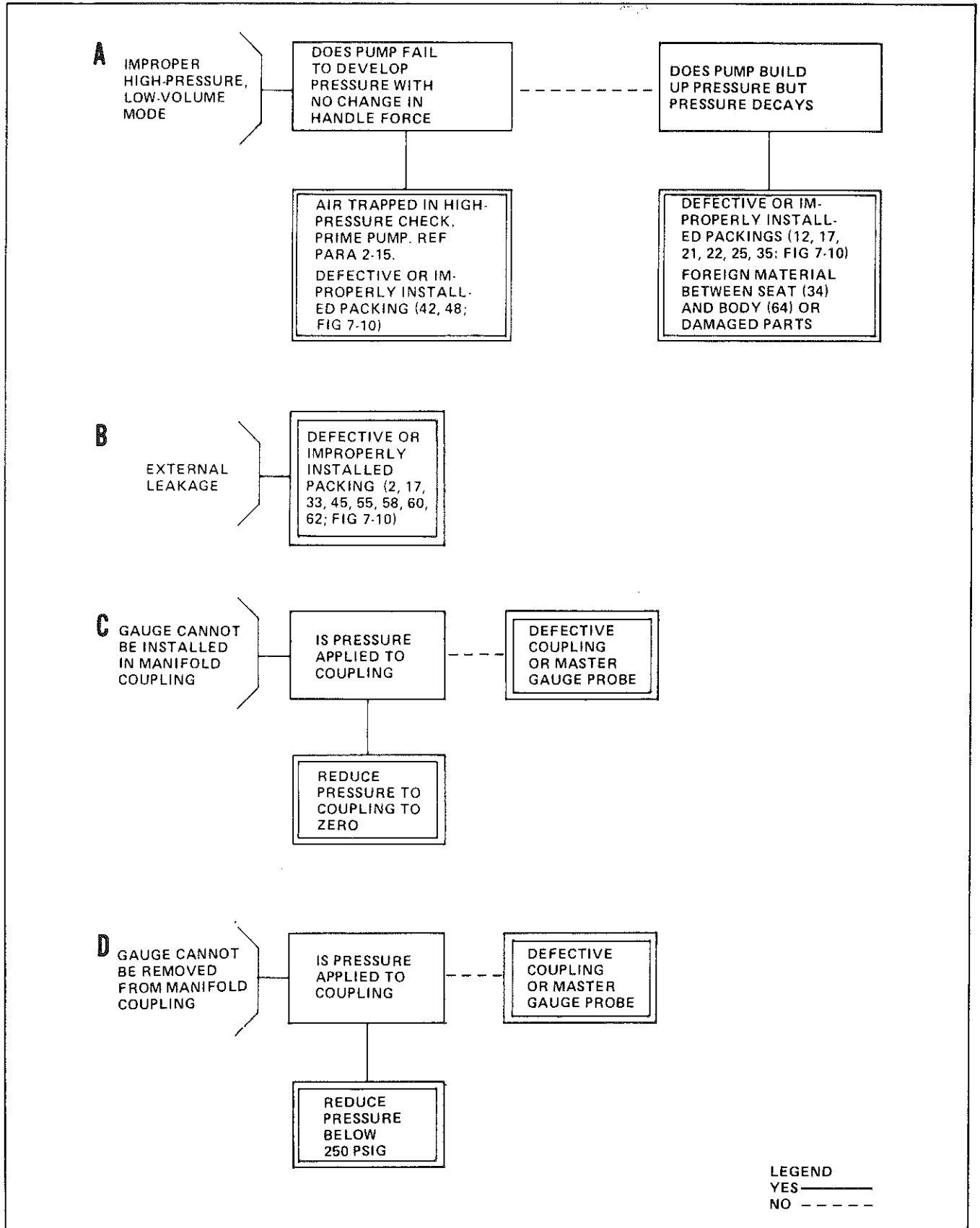

Figure 5-5. Hand Pump Fault Logic Diagram

CHAPTER 6

CORRECTIVE MAINTENANCE

6-1. INTRODUCTION

6-2. Section I of this chapter contains instructions of adjustments and alignments of the portable calibration system, if any. Section II of this chapter contains instructions for the removal and repair of defective replaceable parts.

SECTION I

ADJUSTMENTS AND ALIGNMENTS

6-3. GENERAL

6-4. No adjustments or alignment are applicable to the portable calibration system. If any part is malfunctioning, perform troubleshooting and repair or replace any defective or faulty component or subassembly in accordance with Chapter 5.

SECTION II

REPAIR

6-5. GENERAL

6-6. This section of this chapter provides removal and disassembly, inspection, repair or replacement, cleaning, and reassembly and installation instructions for the replaceable components and subassemblies of the portable calibration system. Refer to Chapter 5 for troubleshooting data for reference in localizing malfunctions; use applicable instructions in this section to return the component to a serviceable condition. Disassemble components and subassemblies only as far as necessary to gain access to the defective part; do not disassemble the equipment beyond the level required for a particular repair, inspection, or test.

6-7. VACUUM PUMP CASE ASSEMBLY REMOVAL AND DISASSEMBLY

6-8. The removal and disassembly instructions in the following paragraphs pertain to the components and subassemblies of the vacuum pump case assembly. Use only

those instructions applicable to the particular part replacement or repair to be accomplished. Maintain a cleanliness level adequate to prevent particles, dirt, and foreign matter from getting into parts of the vacuum pump case assembly while disassembled. Remove power from the vacuum pump, prior to any disassembly or repair, by disconnecting the power cord.

6-9. CHASSIS ASSEMBLY. Remove chassis assembly (2, figure 7-2) from case assembly (54) as follows:

1. Remove four screws (3) securing chassis assembly (2) to case assembly (54). Remove plug (41) from exhaust port (43).

2. Lift chassis assembly (2) up to clear top of case assembly (54), then tilt it forward and rest it on top of the case. Cut cable ties holding power cord (34) to tubing and push power cord through chassis access hole until on/off switch is against access hole. Disconnect plastic tubing from vacuum pump. Place chassis assembly on work surface.

6-10. TUBE ASSEMBLIES REMOVAL. Remove tube assemblies from chassis assembly (2) as follows:

1. Loosen nuts at each end of tube assembly securing tube assembly to fittings.
2. Remove nuts from fittings taking care not to damage fittings.
3. If tube assembly is to remain off fittings for more than a few moments, plug fitting to prevent dirt or contamination from entering system.

6-11. HIGH-PRESSURE QUICK-DISCONNECT SOCKET ASSEMBLY

6-12. Removal. Remove high-pressure quick-disconnect socket assembly (5) from chassis assembly (2) as follows:

1. Remove dust plug assembly (4) from socket. Do not remove plug from panel (33).
2. Remove tube assembly (12, 22) and tee (12A) as required.
3. Remove adapter (13, 14) and nut (15) securing socket to panel.
4. Remove socket from panel.

6-13. Disassembly. Disassemble high-pressure quick-disconnect socket assembly (5) as follows:

1. Place socket assembly on a firm, flat surface with threaded end down.
2. Push down sleeve (2, figure 7-4) to expose retaining ring (1). Remove retaining ring from groove in body (14) and slide off sleeve.
3. With washer (4) restrained against force of spring (5), carefully remove pins (3) to free washer and spring. Discard spring.
4. Remove pins (6) and disassemble parts (7 through 13) from body (14). Discard packings (11, 12).

6-14. COMPOUND GAUGE. Remove compound gauge (6, figure 7-2) from chassis assembly (2) as follows:

1. Remove tube assembly (16) from chassis assembly.
2. Remove nuts securing compound gauge (6) bracket then remove bracket. (Nuts and bracket are part of compound gauge).
3. Remove compound gauge from panel (33).

6-15. THREE-WAY SHUTOFF VALVE. Remove three-way shutoff valve (7) from chassis assembly (2) as follows:

1. Remove knob from valve assembly (2).
2. Remove tube assemblies (18, 19, 20) from elbows (21).
3. Remove panel nut securing valve assembly to panel (33) and remove valve assembly.
4. If valve assembly is to be replaced, remove elbows (21) from valve assembly prior to discarding valve.

6-16. BAUMANOMETER. Remove baumanometer (8) from chassis assembly (2) as follows:

1. Loosen nut on tube assembly (9) from baumanometer adapter.
2. Remove baumanometer from tube assembly (9).

6-17. METERING VALVES

6-18. Removal. Remove metering valve (10) from chassis assembly (2) as follows:

NOTE

Mark chassis panel to indicate direction of flow indication arrow on metering valve to facilitate re-installation.

1. Using a 3/32-inch allen wrench, loosen setscrew and remove handle (1, figure 7-5) from valve (10, figure 7-2).
2. Remove tube assembly (18, 26, 36) from elbow (24, 25, 27).
3. Remove nut (2, figure 7-5) securing valve (10, figure 7-2) to panel (33) and remove valve.

NOTE

Note direction of flow arrow on valve (10) for aid in reassembly.

4. If valve (10) is to be replaced, remove elbows (24, 25, 27) from valve before discarding valve.

6-19. Disassembly. Disassemble metering valves (10) as follows:

1. If installed, remove handle (1, figure 7-5) by loosening setscrew.
2. If installed, remove nut (2) from bonnet (3).

3. Unscrew counterclockwise and remove bonnet (3) from body (8).

4. Remove and discard packing (4) from bonnet.

5. Screw stem (5) clockwise through the bonnet and remove.

6. Remove and discard packing (6) from stem.

7. Remove and discard seat (7).

6-20. VERNIER VALVE ASSEMBLY

6-21. Removal. Remove vernier valve assembly (11, figure 7-2) from chassis assembly (2) as follows:

1. Remove tube assemblies (16, 22) from tee (23). Remove tube assemblies (19, 26) from tee (28).

2. If valve is to be replaced, remove items 23 and 28 through 31 from vernier valve.

3. Using a 3/32-inch allen wrench, loosen setscrews (1, figure 7-6) and remove knob (3) from stem (10).

4. Remove nut (4) and washer (5) from body (15).

5. Remove vernier valve (11, figure 7-2) from panel (33).

6-22. Disassembly. Disassemble vernier valve (11) as follows:

1. If installed, loosen setscrews (1, figure 7-6) and remove knob (3) from stem (10).

2. If installed, remove nut (4) and washer (5) from body (15).

3. Remove key assembly (6) and snap ring (7). Remove parts (8 through 14) by pulling stem (10) from body (15).

4. Remove retainer (8) and thrust bearing assembly (9) from stem (10).

NOTE

Stem (10) utilizes left hand threads and unscrews in a clockwise direction.

5. Unscrew clockwise and remove stem (10) from piston (14). Remove thrust bearing (11).

6-23. RELIEF VALVE

6-24. Removal. Remove relief valve (29, figure 7-2) from chassis assembly (2) by unscrewing valve from tee (30).

6-25. Disassembly. Disassemble relief valve (29) as follows:

1. Back off check nut (6, figure 7-14) from cap (1) and remove cap.

2. Remove spring (2), guide (3) from body (7). Remove and discard seal (4) from guide.

3. Remove poppet (5) from body (7).

4. Remove check nut (6) from body (7).

6-26. PUMP ASSEMBLY

6-27. Removal. Remove pump assembly (36 thru 53) from chassis assembly as follows:

1. Verify that power cord (34) is disconnected from power source.

2. Reinstall plug (41) in spool (43).

3. Turn case (54) on its side. Hold pump (53) and remove pump mounting screws (35).

4. Remove pump from case.

6-28. Disassembly. Disassemble pump assembly (36 thru 63) as follows:

1. If installed, remove plug (41) from spout (43).

2. Remove drain plug and operate pump for a short time to pump oil out of drain hole.

3. Remove spout (43) from pump (53). Remove and discard packing (42) and gasket (44).

4. If installed, remove elbow (37) from pump (53).

5. Remove relief valve (38) and adapter (39) from pump (53). Remove and discard gasket (40).

6. Remove screws (47), nuts (46), and washers (48) securing feet (45) to base plate (50) and remove feet.

7. Remove nuts (49) from base plate (50).

8. Remove screws (51) and washers (52) securing base plate (50) to pump (53) and remove base plate.

NOTE

Due to critical tolerances and surface finishes on internal pump parts, the pump should be returned to the factory for overhaul or repair.

6-29. TEST HOSE ASSEMBLY. Disassemble test hose assembly (1) as follows:

1. Remove dust plug assembly (1 and 2, figure 7-3) from socket assembly (3). Disassemble chain assembly (1) from plug (2).

2. Unscrew and remove socket assembly from adapter (4). Refer to paragraph 6-13 for disassembly of the high-pressure quick-disconnect socket assembly.

3. Remove dust cover assembly (5) from probe (6).
4. Remove probe (6) from adapter (7).
5. Remove adapters (4, 7) from nuts (8).

6-30. HAND PUMP CASE ASSEMBLY REMOVAL AND DISASSEMBLY

6-31. The removal and disassembly instructions in the following paragraphs pertain to the components and subassemblies of the hand pump case assembly. Use only those instructions applicable to the particular part replacement or repair to be accomplished. Maintain a cleanliness level adequate to prevent particles, dirt, and foreign matter from getting into parts of the hand pump case assembly while disassembled.

6-32. HOSE ASSEMBLIES. Disassemble high-pressure hose assemblies (1, 2; figure 7-7) as follows:

1. Remove dust plug assembly (1 and 2, figure 7-8) from socket assembly (3). Disassemble chain assembly (1) from plug (2).
2. Unscrew and remove socket assembly from hose (8). Refer to paragraph 6-13 for disassembly of the high-pressure quick-disconnect socket assembly.
3. Remove dust cover from probe (7) and disassemble chain assembly (4) and body (6). Remove and discard packing (5) from body.
4. Remove probe (7) from hose (8).

6-33. HAND PUMP ASSEMBLY

6-34. Removal. Remove four screws (5, figure 7-7) and washers (6) and remove hand pump assembly (7 thru 15) from case (16).

6-35. Disassembly. Disassemble the hand pump assembly as follows:

1. Remove the dust plug assemblies (7) from high-pressure quick-disconnect socket assemblies (8).
2. Remove socket assemblies. Refer to paragraph 6-13 for disassembly of the high-pressure quick-disconnect socket assembly.
3. Remove stem assembly (9) from body (10).
4. Remove body (10) from union nut (12). Remove and discard packing (11).
5. Remove nipple (13) from adapter (14).
6. Remove union nut (12) from nipple (13).

7. Remove adapter (14) from hand pump (15).

6-36. HAND PUMP. Disassemble the hand pump (15, figure 7-7) as follows:

1. Remove fill and vent plug (1, figure 7-10) from body (64). Remove and discard packing (2). Drain water from pump reservoir.
2. Remove retaining ring (3) securing upper pin (4) and remove pin from handle (8).
3. Remove retaining ring (3) securing lower pin (5) and remove pin from handle (8) and body (64). Remove link (6) and pin (7).
4. Remove handle assembly (7 and 8) with parts (9 through 16) attached. Loosen setscrew in pinion (9) with a 3/32-inch allen wrench.

NOTE

Count the number of threads showing above pinion for reference during reassembly.

5. Using a 1/8-inch diameter rod, unscrew piston assembly (10 through 16) from pinion (9). Using a 3/16-inch allen wrench, unscrew closure (10) from piston (16). Remove pinion from handle (8).
6. Insert a 6-32 screw into seat (11) and pull seat from piston (16). Remove ball (15) and spring (14) from piston. Remove and discard packings (12, 17) and retainers (13, 18).
7. Remove gland (19) from body (64).
8. Remove sleeve (20) from body. Remove and discard wiper (21), packing (22), and retainer (23) from sleeve.
9. Remove slide insert (24), packing (25), retainer (26), and bushing (27). Discard packing and retainer.
10. Remove pin (28) securing lever assembly (29) to stem (30) and remove lever assembly.
11. Remove housing (32) from body (64). Remove and discard packing (33).
12. Remove stem (30) from housing (32). Remove and discard packing (31).
13. Remove seat (34) and packing (35) from body (64). Discard packing (35).
14. Remove four bolts (36) and washers (37) securing flange (38) to body (64) and remove flange.
15. Remove nipple (39), packing (40), spring (41), valve (42) and packing (43) from body (64). Discard packings.

16. Remove plug (44) from body (64). Remove spring (46) and valve (47). Remove and discard packings (45, 48).

17. Remove screw (49) securing button (50) and remove button from guide (54).

18. Remove guide (54) from body (64). Remove ring (53) from guide. Remove and discard packing (55).

19. Remove plunger (51) from body (64). Remove and discard packing (52). Remove ball (56).

20. Remove plug (57) from shell (61). Remove and discard packing (58) from plug.

21. Remove shell (61) from body (64). Remove and discard packing (62).

22. Remove retainer nut (59) from shell (61). Remove and discard packing (60) from nut. Remove tie rod (63).

6-37. GAUGE CASE ASSEMBLY COMPONENTS DISASSEMBLY

6-38. The disassembly instructions in the following paragraphs pertain to the subassemblies of the gauge case assemblies. Use only those instructions applicable to the particular part replacement or repair to be accomplished. Maintain a cleanliness level adequate to prevent particles, dirt, and foreign matter from getting into parts of the disassembled subassemblies.

6-39. HIGH PRESSURE MASTER GAUGE ASSEMBLIES. Disassemble master gauge assemblies (2, 6, 10, 19, 23, 27; figure 7-11) as follows:

1. Remove dust cover (3, 7, 11, 20, 24, 28). Remove and discard packing from cover.

2. Remove probe (4, 8, 12, 21, 25, 29) from gauge (5, 9, 13, 22, 26, 30).

6-40. FLUID SEPARATOR. Disassemble fluid separator (14, 31) as follows:

1. Before disassembling fluid separator, remove fill plugs (6, figure 7-12) and drain water and oil into suitable containers. Remove and discard packings (7) from plugs.

2. Remove dust plug assembly (1) from socket assembly (2).

3. Remove socket assembly from adapter (3). Refer to paragraph 6-13 for disassembly of socket assembly. Remove adapter.

4. Remove dust cover (4) from probe (5).

5. Remove probe from head (12).

6. Remove nine nuts (8), fourteen washers (9), nine bolts (10), and two brackets (11) from body (24).

7. Separate head (12) from body (24). Separate valve retainer (13), valve (14), and spring (16) from head. Remove packing (15) from valve. Discard packing.

8. Remove diaphragm (17), valve (18), and spring (20) from body (24). Remove packing (19) from valve. Discard packing.

9. Do not remove label (21), or plates (22, 23) unless replacement is required.

6-41. LOW PRESSURE AND VACUUM MASTER GAUGE ASSEMBLIES. Disassemble master gauge assemblies (1, 5; figure 7-13) as follows:

1. Remove dust cover (2, 6). Remove and discard packing from dust cover.

2. Remove probe (3, 7) from gauge (4, 8).

6-42. INSPECTION

6-43. Perform the following inspections:

1. Visually check the security of all parts not removed.

2. Visually check all threaded parts for crossed or damaged threads.

3. Visually check that all parts are clean, free of cracks, corrosion, deterioration, or other damage.

4. Visually check packing grooves for surface defects that might cut packings during installation or cause sealing failures during operation.

6-44. VERNIER CONTROL VALVE. Check vernier control valve (11, figure 7-2) as follows:

1. Check thrust bearings (9, 11; figure 7-6) for evidence of wear and surface imperfections that may prevent smooth operation with stem (10).

2. Check piston (14) guide for evidence of wear and surface imperfections that may prevent smooth operation with key assembly (6) and body (15).

6-45. HIGH-PRESSURE HOSE ASSEMBLIES. Check high-pressure hose assemblies (1, 2; figure 7-7) as follows:

1. Check hoses for cut or cracked tubes.

2. Loosen cover fitting of hose assembly and inspect brazed joint between capillary tube and end fitting for evidence of damage. Inspect end of hose for kinks. (See figure 6-1.)

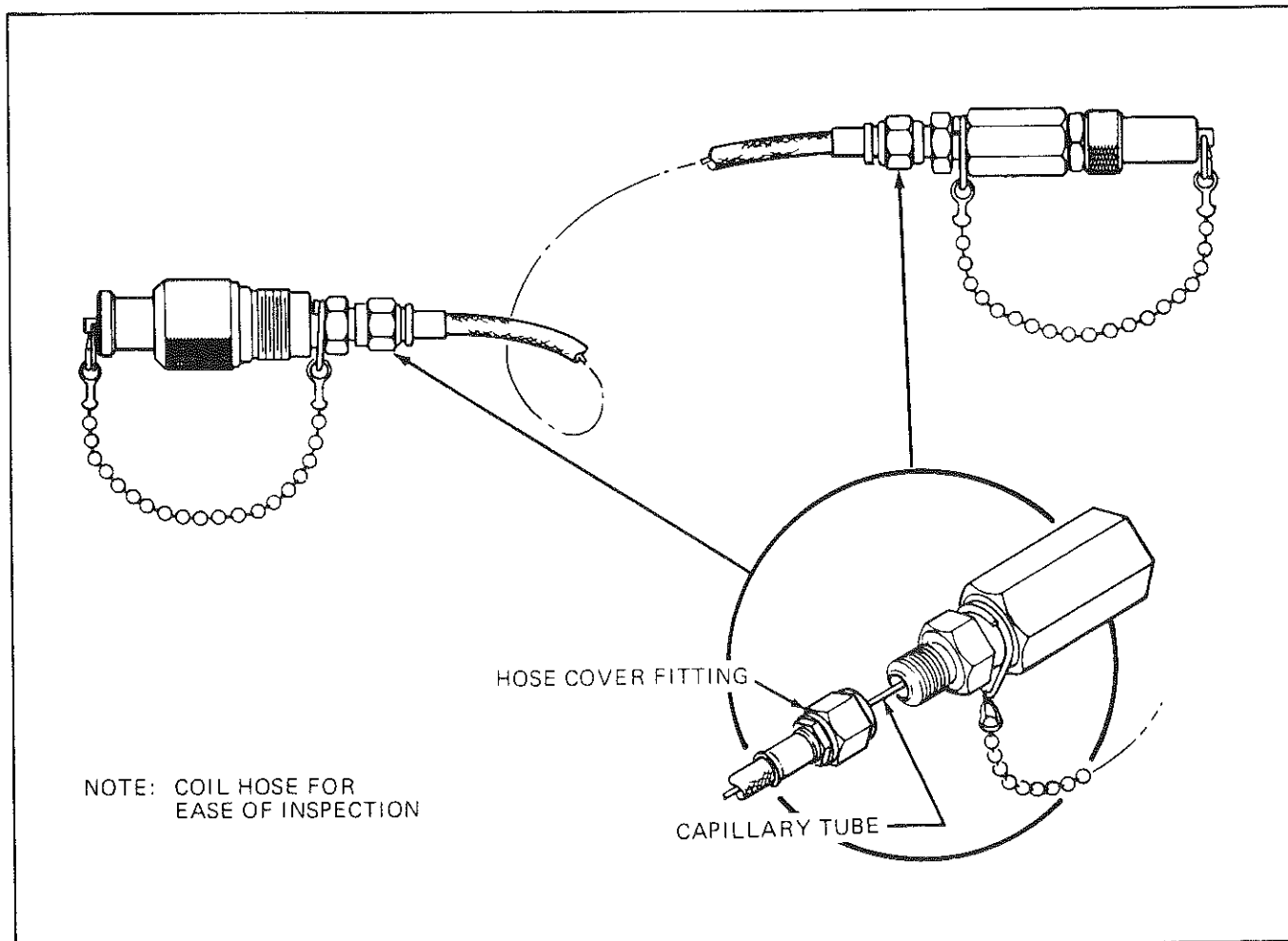

Figure 6-1. Inspection of High-Pressure Hose

6-46. HAND PUMP ASSEMBLY. Check hand pump assembly (7 through 15, figure 7-7) as follows:

1. Check seating and sealing surfaces of check valves (42, 47; figure 7-10) for any evidence of surface marks that might prevent an effective seal during operation.
2. Check bushing (27) and insert (24) for evidence of wear or markings.
3. Inspect guide (54) and plunger (51) for surface imperfections.

6-47. REPAIR AND REPLACEMENT

6-48. Repair shall be limited to the following operations:

1. Polish out minor nicks and scratches on metal parts with crocus cloth, Federal Specification P-C-458, for steel parts, and Number 600 to 800 grade aluminum-oxide abrasive cloth, Federal Specification P-C-451, for aluminum parts.

NOTE

After completion of polishing, reclean parts in accordance with paragraph 6-49.

2. Repair minor damage (less than one-half of one thread) to threaded parts by chasing with proper tap or die. Replace all damaged standard hardware such as screws and bolts.
3. Replace all soft seats, gaskets, and packings during each disassembly, regardless of condition.
4. Replace all other worn or damaged parts which cannot be reworked to meet inspection requirements.

6-49. CLEANING

6-50. Thoroughly clean all parts with precision cleaning fluid, Freon TF or Freon 113 (DuPont), or equivalent. Dry all parts thoroughly with clean, compressed air at low pressure.

6-51. GAUGE CASE ASSEMBLY COMPONENTS REASSEMBLY

6-52. LOW PRESSURE AND VACUUM MASTER GAUGE ASSEMBLIES. Reassemble master gauge assemblies (1, 5; figure 7-13) as follows:

1. Wrap male threads of probe (3, 7) with teflon tape, Military Specification MIL-T-27730.
2. Install ring on loose end of chain on dust cover (2, 6) on master gauge.
3. Install probe into master gauge (5, 8).
4. Lightly lubricate new dust cover packing with lubricant, Part No. 3460-80-1 (part of packing kit (9)), and install on dust cover.
5. Install dust cover on probe.

6-53. HIGH PRESSURE MASTER GAUGE ASSEMBLIES. Reassemble master gauge assemblies (2, 6, 10, 19, 23, 27; figure 7-11) as follows:

1. Wrap male threads of probe (4, 8, 12, 21, 25, 29) with teflon tape, Military Specification MIL-T-27730.
2. Install ring on loose end of chain on dust cover (3, 7, 11, 20, 24, 28) on master gauge.
3. Install probe into master gauge.
4. Lightly lubricate new dust cover packing with lubricant Part No. 3460-80-1 (part of packing kit (9, figure 7-13)) and install on dust cover.
5. Install dust cover on probe.

6-54. FLUID SEPARATOR. Reassemble fluid separator (14, 31) as follows:

1. Lightly lubricate new packings (7, 15, 19; figure 7-12) with lubricant Part No. 3460-80-1 (part of packing kit (9, figure 7-13)). Install packings (15, 19; figure 7-12) in external grooves of valves (14, 18). Install packing (7) in external groove of fill plug (6).

NOTE

Perform steps 2 through 6 with body (24) held upright (bore up).

2. Install spring (20) and valve (18) in port of body (24).
3. Insert new diaphragm (17) in bore of body. Make certain that diaphragm lip seats in body groove.

4. Insert spring (16) and valve (14) in port of head (12). Install valve retainer (13) to hold parts in place.

5. Place head (12) and assembled parts in position on body (24). Install brackets (11), bolts (10), washers (9), and nuts (8).

6. Tighten nuts (8) to a torque value of 50 foot-pounds in the sequence shown in figure 6-2.

7. Install adapter (3) into body (24).

8. Install ring on loose end of chain on dust cover (1) on adapter (3) and install socket assembly (2) on adapter.

9. Install probe (5) and dust cover (4) on head (12).

10. Using the appropriate liquid charger (1, 18; figure 7-11) fill the test gauge side with hydraulic oil or compressor oil. Force diaphragm of separator to pump side by filling with charger. Keep spout of liquid charger firmly pressed in fill port to prevent spillage. After filling, install and tighten plug (6, figure 7-12).

11. Fill pump side of fluid separator with distilled water and install plug (6).

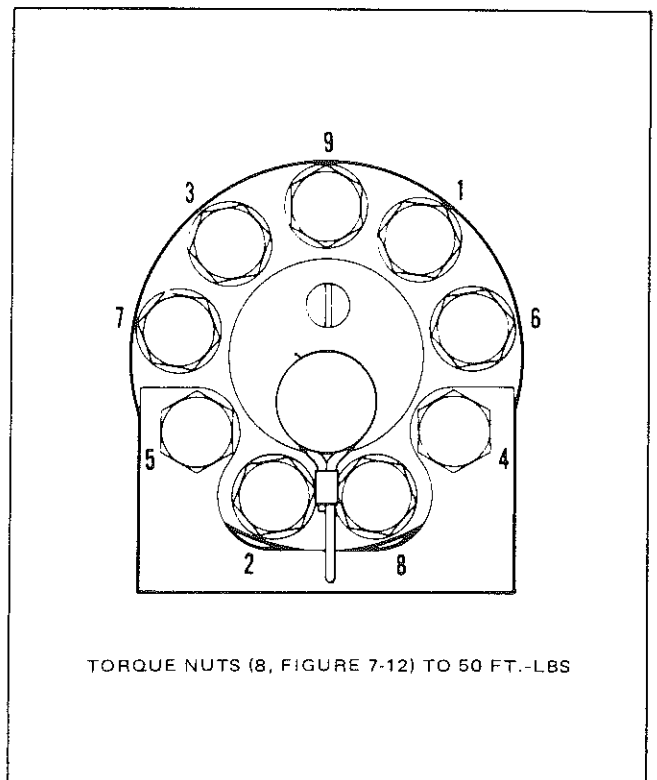

Figure 6-2. Fluid Separator Torque Sequence

6-55. HAND PUMP CASE ASSEMBLY REASSEMBLY

6-56. HAND PUMP. Assemble the hand pump (15, figure 7-7) as follows.

1. Apply a light coating of lubricant, Part No. 3460-80-1 (part of packing kit (9, figure 7-13)), to all packing to facilitate reassembly.

2. Install tie rod (63, figure 7-10) in shell (61). Install new packing (60) on retainer nut (59) and install nut on shell.

3. Install new packing (62) on body (64) and install shell (61) on body.

4. Install new packing (58) on plug (57) and install plug on shell (61).

5. Install new packing (55) on guide (54) and install new packing (52) on plunger (51). Install guide and plunger in body (64).

6. Coat ball (56) with lubricant, Part No. 3460-80-1 (part of packing kit (9, figure 7-13)) to aid in retaining ball while compression ring (53, figure 7-10) is being installed.

7. Insert ball (56) in one hole of guide (54). Slide compression ring (53) on guide until tab snaps into hole in guide opposite ball.

8. Install button (50) on guide (54) and secure with screw (49).

9. Install new packing (48) on valve (47) and new packing (45) on plug (44). Install valve, spring (46) and plug in body (64).

10. Install new packing (43) on valve (42) and new packing (40) on nipple (39). Install valve, spring (41), nipple in body (64). Install flange (38) and secure with screws (36) and washers (37).

11. Install new packing (35) on seat (34), new packing (33) on housing (32), and new packing (31) on valve stem (30). Install valve stem (30) in housing (32) and install seat (34) and housing (32) in body (64). Install lever assembly (29) on valve stem and secure with spring pin (28).



Packings and retainers associated with piston and related parts must be installed in exact locations shown in figure 6-3.

12. Install new packing (25) and retainer (26) on insert (24). Install bushing (27) and insert in body (64).

13. Install retainer (23) and new packings (21, 22) on sleeve (20). Install sleeve in body (64).

14. Install gland (19) in body (64).

15. Install new packing (12) and retainer (13) on seat (11). Install new packing (17) and retainer (18) on piston (16).

16. Insert a 6-32 screw into seat then insert spring (14), ball (15) and seat into piston. Remove 6-32 screw from seat. Install closure (10) into piston and tighten with a 3/16-inch allen wrench to tighten until bottomed. Use care to ensure proper seating of ball (15) on seat (11).

17. Install pinion (9) on handle (8). If removed, install spring pin (7) on handle. Screw piston assembly (10 thru 18) into pinion to expose same number of threads as noted during disassembly. This determines handle position. Tighten pinion setscrew.

18. Install link (6) and secure with pins (4, 5). Secure pins with retaining rings (3).

19. Fill and prime hand pump reservoir with distilled water in accordance with paragraph 2-15.

20. Install new packing (2) on plug (1) and install plug on body (64).

6-57. HAND PUMP ASSEMBLY

6-58. Reassembly. Reassemble the hand pump assembly as follows:

1. Install adapter (14, figure 7-7) on hand pump (15).

2. Install union nut (12) on nipple (13).

3. Wrap male threads of nipple (13) with teflon tape, Military Specification MIL-T-27730. Install nipple on adapter (14).

4. Install new packing (11) on body (10) and install body on union nut (12).

5. Install stem assembly (9) into body (10).

6-59. Installation. Install hand pump assembly (7 thru 15) in position in case (16) and secure with screws (5) and washers (6).

6-60. VACUUM PUMP CASE ASSEMBLY REASSEMBLY

6-61. TUBE ASSEMBLY INSTALLATION. Install tube assemblies into chassis assembly (2, figure 7-2) as follows:

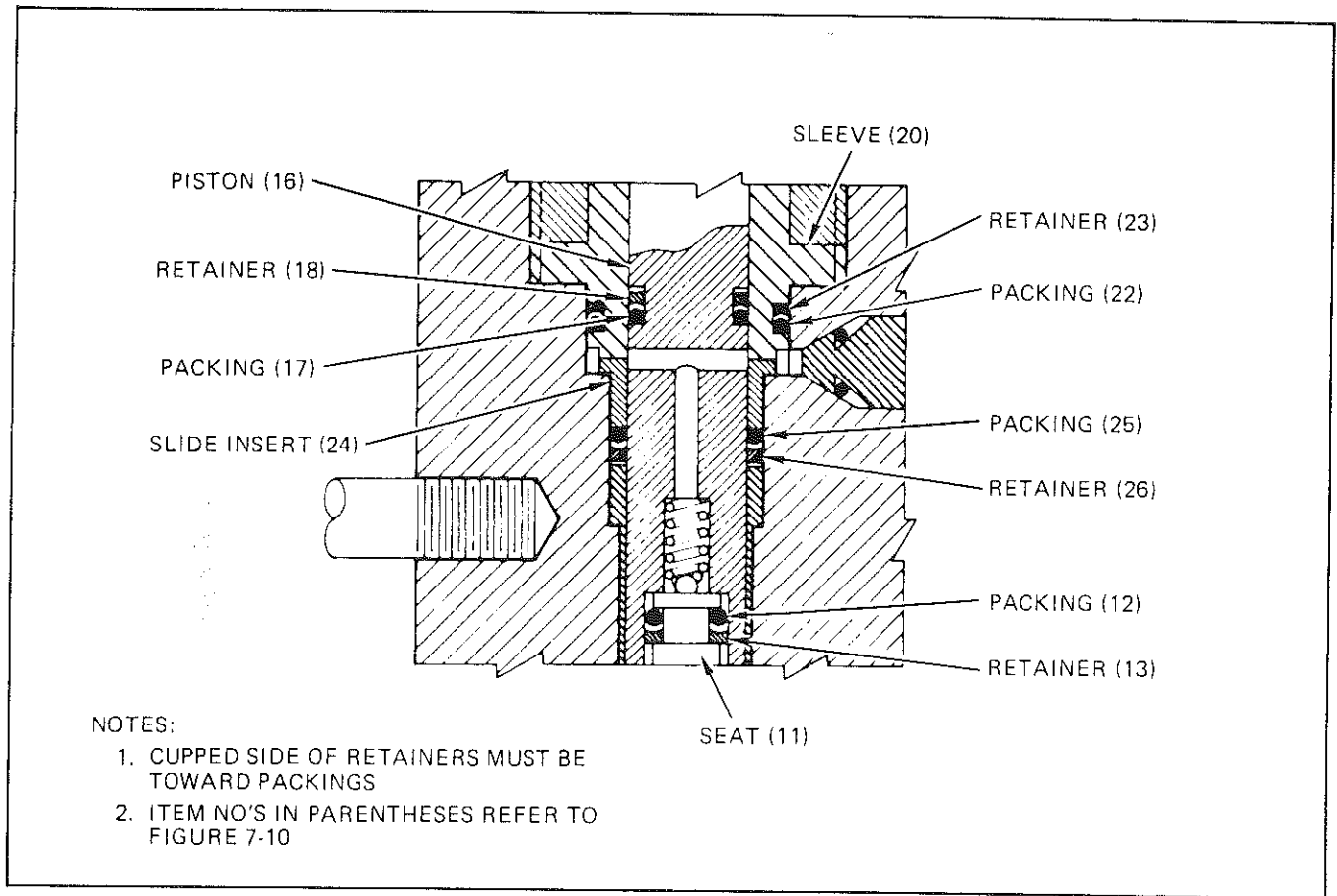

Figure 6-3. Packing and Retainer Installation

1. Remove any plugs temporarily installed to prevent contamination of tube assemblies.

2. Position tube assemblies in place.

3. Carefully hand tighten tube assembly nuts. Using one wrench to hold adapters in place and a second wrench on tube assembly nuts carefully tighten nuts. Do not use teflon tape on flared fittings.

6-62. TEST HOSE ASSEMBLY REASSEMBLY. Assemble test hose assembly (1) as follows:

1. Install guards (9) on tube (10) then install nuts (8).

2. Install adapters (4, 7) on nuts (8).

3. Position dust cover (5) ring on adapter (7) and install probe (6). Install dust cover over probe.

4. If disassembled, assemble chain (1) and plug (2). Install plug assembly ring on adapter (4) and install socket assembly (3) on adapter. Install plug assembly in socket assembly.

6-63. PUMP ASSEMBLY

6-64. Reassembly. Assemble vacuum pump assembly (36 thru 53) as follows:

1. Position base plate (50) in place on pump (53) and secure with screws (51) and washer (52).

2. Install nuts (49) on base plate (50).

3. Position feet (45) in place on base plate (50) and secure with screws (47), nuts (46), and washers (48).

4. Install new gasket (40) and adapter (39) on pump (53). Wrap male threads of relief valve (38) with teflon tape, Military Specification MIL-T-27730, and install relief valve on adapter.

5. Wrap male threads of elbow (37) mating with pump (53), with teflon tape, Military Specification MIL-T-27730, and install elbow on pump. Do not wrap flare fitting mating with tube (36) with teflon tape.

6. Install new gasket (44) and packing (42) on spout (43) and install spout on pump (53).

7. Do not install plug (41) at this time.

6-65. Installation. Install vacuum pump assembly (36 thru 53) as follows:

1. Position pump assembly (36 thru 53) in place on case assembly (54) and secure with bolts (35).
2. Install tube assembly (36) to elbows (25, 37).
3. Run power cord (34) through chassis assembly (2) and connect to pump (53).
4. Install chassis assembly (2) in accordance with paragraph 6-75.
5. Add DuoSeal oil (or equivalent) to vacuum pump assembly (36 thru 53) through spout (43) until oil is visible in sight gauge.
6. Install new gasket (42) on plug (41) and install plug on spout (43).

6-66. RELIEF VALVE INSTALLATION. Wrap male threads of relief valve (29) with teflon tape, Military Specification MIL-T-27730, and install in tee (30).

6-67. VERNIER VALVE ASSEMBLY

6-68. Reassembly. Assemble vernier valve (11) as follows:

NOTE

Lightly lubricate packings with lubricant, Part No. 3460-80-1 prior to assembly.

1. Install new packing (12, figure 7-6) and retainer (13) on piston (14).
2. Install thrust bearing (11) on stem (10).
3. Install thrust bearing assembly (9) and retainer (8) on stem (10). Thread stem into piston. Note that threads are left hand.
4. Install parts (8 thru 14) into body then install key assembly (6) and snap ring (7). Make sure key assembly engages groove in piston (14).
5. Do not install parts (1 thru 5) at this time.

6-69. Installation. Install vernier valve assembly (11, figure 7-2) as follows:

1. Position vernier valve assembly (11) in place on panel (33).
2. Install nut (4, figure 7-6) and washer (5) on body (15) securing vernier assembly (11, figure 7-2) to panel (33).

3. Wrap male threads of tees (23, 28) mating with vernier valve assembly (11) with teflon tape, Military Specification MIL-T-27730. Do not wrap flare fittings mating with tube assemblies (16, 19, 22, 26). Install tees on valve assembly.

4. Install tube assemblies (19, 26) on tee (28) and tube assemblies (16, 22) on tee (23).

5. Install knob (3, figure 7-6) on stem (10) and using a 3/32 in. allen wrench, secure with setscrew (1). Make sure setscrews engage flats on stem.

6-70. METERING VALVES

6-71. Reassembly. Assemble metering valves (10, figure 7-2) as follows:

1. Install new packing (6, figure 7-5) and new seat (7) on stem (5).

2. Install stem (5) in bonnet (3) by turning stem clockwise into bottom of bonnet. Screw stem all of the way into bonnet to prevent damage to seat (7) during installation of bonnet into body (8).

3. Install new packing (4) on bonnet (3) and install bonnet into body (8) by turning bonnet clockwise.

4. Do not install handle (1) and lock nut (2) at this time.

6-72. Installation. Install metering valves (10, figure 7-2) as follows:

1. Wrap male threads of elbows (25, 27; figure 7-2) mating with valves (10) with teflon tape, Military Specification MIL-T-27730. Do not wrap flare fittings mating with tube assemblies (18, 26, 36). Install tees on valves.

2. Position each metering valve (10) in place on panel (33). Insure that flow arrow is same position as noted during disassembly and secure with nut (2, figure 7-5).

3. Install handle (1) and secure with setscrew.

4. Install tube assemblies (18, 26, 36) on elbows (25, 27).

6-73. BAUMANOMETER. Install baumanometer (8) as follows:

1. Position baumanometer (8) in place.

2. Tighten nut on tube assembly (9) to secure baumanometer (8) to tube assembly.

6-74. **THREE-WAY SHUTOFF VALVE.** Install three-way shutoff valve (7) as follows:

1. Wrap male threads of elbows (21) mating with valve (7) with teflon tape, Military Specification MIL-T-27730, and install elbows on valve. Do not wrap flare fittings mating with tubes (18, 19, 20) with teflon tape.
2. Position valve (7) in place on panel (33) and secure with panel nut.
3. Install tubes (18, 19, 20) on elbows (21).
4. Install knob on valve (7).

6-75. **COMPOUND GAUGE.** Install compound gauge (6) as follows:

1. Install adapter (17) on compound gauge (6).
2. Position compound gauge (6) in position on panel (33).
3. Position compound gauge (6) bracket in position behind gauge and secure with nuts. (Nuts and bracket are part of compound gauge.)
4. Install tube assembly (16).

6-76. **HIGH-PRESSURE QUICK-DISCONNECT SOCKET ASSEMBLY**

6-77. **Reassembly.** Assemble high-pressure quick-disconnect socket assembly (5) as follows:

1. Install spring (8, figure 7-4). Install spool (9) on stem. Install new packings (11, 12) and retainers (10, 13).
2. Install assembled parts (7 thru 13) into body (14) and install pins (6).
3. Place socket assembly on a firm, flat surface with threaded end down.
4. Install spring (5) and washer (4) on body (14). Compress spring by pressing on washer and install pins (3).
5. Install sleeve (2) over body (14). Press sleeve down and install retaining ring (1).

6-78. **Installation.** Install high-pressure quick-disconnect socket assembly (5, figure 7-2) as follows:

1. Position socket assembly (5) in place on panel (33) and secure with nut (15).
2. Install adapter (13, 14). Wrap male threads of tee (12A) mating with adapter (13) with teflon tape, Military Specification MIL-T-27730, and install on adapter. Do not

wrap flare fittings mating with tube assemblies (12, 22) with teflon tape.

3. Install tube assemblies (12, 22).
4. Insert dust plug assembly (4) into socket (5).

6-79. **RELIEF VALVE REASSEMBLY.** Reassemble relief valve as follows:

1. Install check nut (6, figure 7-14) on body (7). Thread all the way down on body but leave loose.
2. Install poppet (5) into body (7).
3. Install new seat (4) and guide (3) and install guide into body (7).
4. Install spring (2) into body and install cap (1). Thread cap hand tight and tighten check nut against cap while holding cap to prevent turning.

6-80. **CHASSIS ASSEMBLY.** Install chassis assembly (2) as follows:

1. Lower chassis assembly (2) straight down into case assembly (54) taking care not to damage components attached to chassis assembly.
2. Position chassis assembly (2) in place and secure with screws (3).

6-81. ADJUSTMENTS

6-82. No adjustments are required of the portable calibration system.

6-83. INSTALLATION

6-84. Refer to Chapter 8.

6-85. CALIBRATION

6-86. Calibration of the master gauge assemblies shall be performed by gauge calibration laboratory traceable to a primary standard.

6-87. CHECKOUT

6-88. Checkout repaired equipment by setting up in a normal operating installation, then pump up pressure or vacuum, as applicable to the maximum value for the components under test. Allow approximately ten minutes for thermal stabilization, then observe system for a five-minute period. Pressure variation shall not exceed one percent.

CHAPTER 7

PARTS LIST

7-1. INTRODUCTION

7-2. This chapter covers a list of major units and provides an illustrated list of replaceable parts for the portable calibration system.

7-3. LIST OF MAJOR UNITS

7-4. The major units of the portable calibration system are listed in figure 7-1 and associated parts list.

7-5. PARTS LIST

7-6. This parts list contains a list of the parts that make up the assemblies, subassemblies, and detail parts of the portable calibration system, Part No. 3657-1-1. The parts list is keyed by index numbers to the associated illustrations (figures 7-1 through 7-13). If the part number is known refer to the parts list, find the part number in that list, and note the index number for that part; the part may then be visually found on the related illustration by means

of the index number. If the part is known, locate it on the illustration and note the index number assigned to that part. Using this index number the part number and other applicable data may be found in the related parts list.

7-7. LIST OF MANUFACTURERS

7-8. A five-digit code number following the description of the part indicates the identity of the manufacturer. If no code number appears, the part number is that of King Nutronics Corporation or standard part (AN, MS, etc.). The following manufacturer's codes, and their corresponding manufacturer's names and addresses are used in this manual.

CODE
NUMBER

MANUFACTURER'S
NAME AND ADDRESS

13859

King Nutronics Corporation
6421 Independence Avenue
Woodland Hills, CA 91364

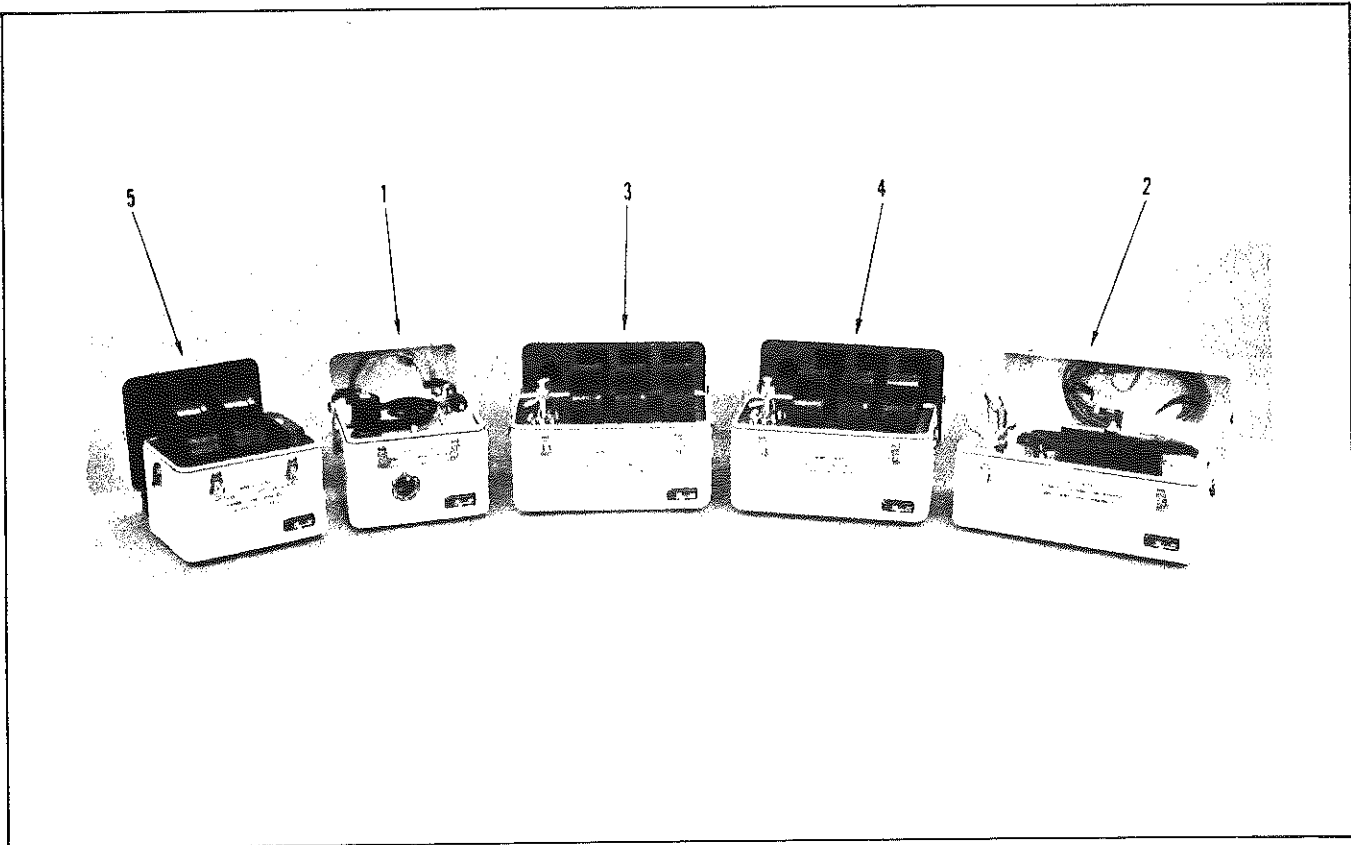

Figure 7-1. Portable Calibration System, Model 3657, Part No. 3657-1-1

FIGURE AND INDEX NUMBER	PART NUMBER	DESCRIPTION	NOTES
7-1-	3657-1-1	SYSTEM, PORTABLE CALIBRATION, MODEL 3657 (13859)	
-1	3657-51-1	. CASE ASSY, VACUUM PUMP SEE FIGURE 7-2 FOR DETAILS	
-2	3657-45-1	. CASE ASSY, HANDPUMP SEE FIGURE 7-7 FOR DETAILS	
-3	3657-29-3	. CASE ASSY, GAUGE (1000, 3000, AND 10,000 PSI RANGE MASTER GAUGES) SEE FIGURE 7-11 FOR DETAILS	
-4	3657-29-1	. CASE ASSY, GAUGE (30, 100, AND 300 PSI RANGE MASTER GAUGES) SEE FIGURE 7-11 FOR DETAILS	
-5	3657-28-1	. CASE ASSY, GAUGE (VACUUM AND 15 PSI RANGE MASTER GAUGES) SEE FIGURE 7-13 FOR DETAILS	

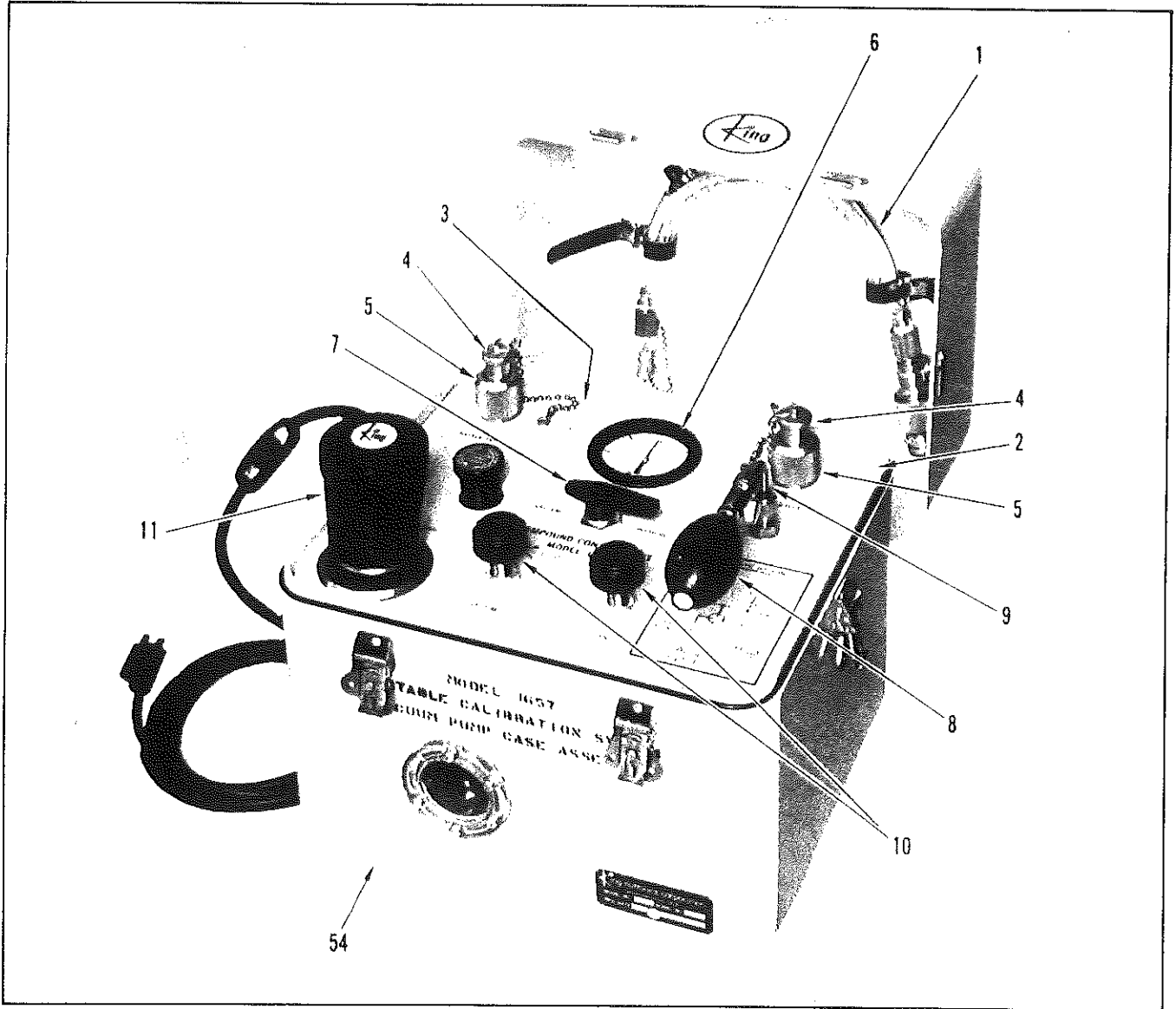

Figure 7-2. Vacuum Pump Case Assembly, Part No. 3657-51-1
(Sheet 1 of 2)

FIGURE AND INDEX NUMBER	PART NUMBER	DESCRIPTION	NOTES
7-2-	3657-51-1	CASE ASSY, VACUUM PUMP	
-1	3460-104-1200	HOSE ASSY, TEST	
-2	3657-46-1	SEE FIGURE 7-3 FOR DETAILS	
-3	AN507-1032R8	CHASSIS ASSY	
-4	3460-135-5	(ATTACHING PARTS)	
		SCREW	4 REQ
		...*...	
		PLUG ASSY, DUST	2 REQ

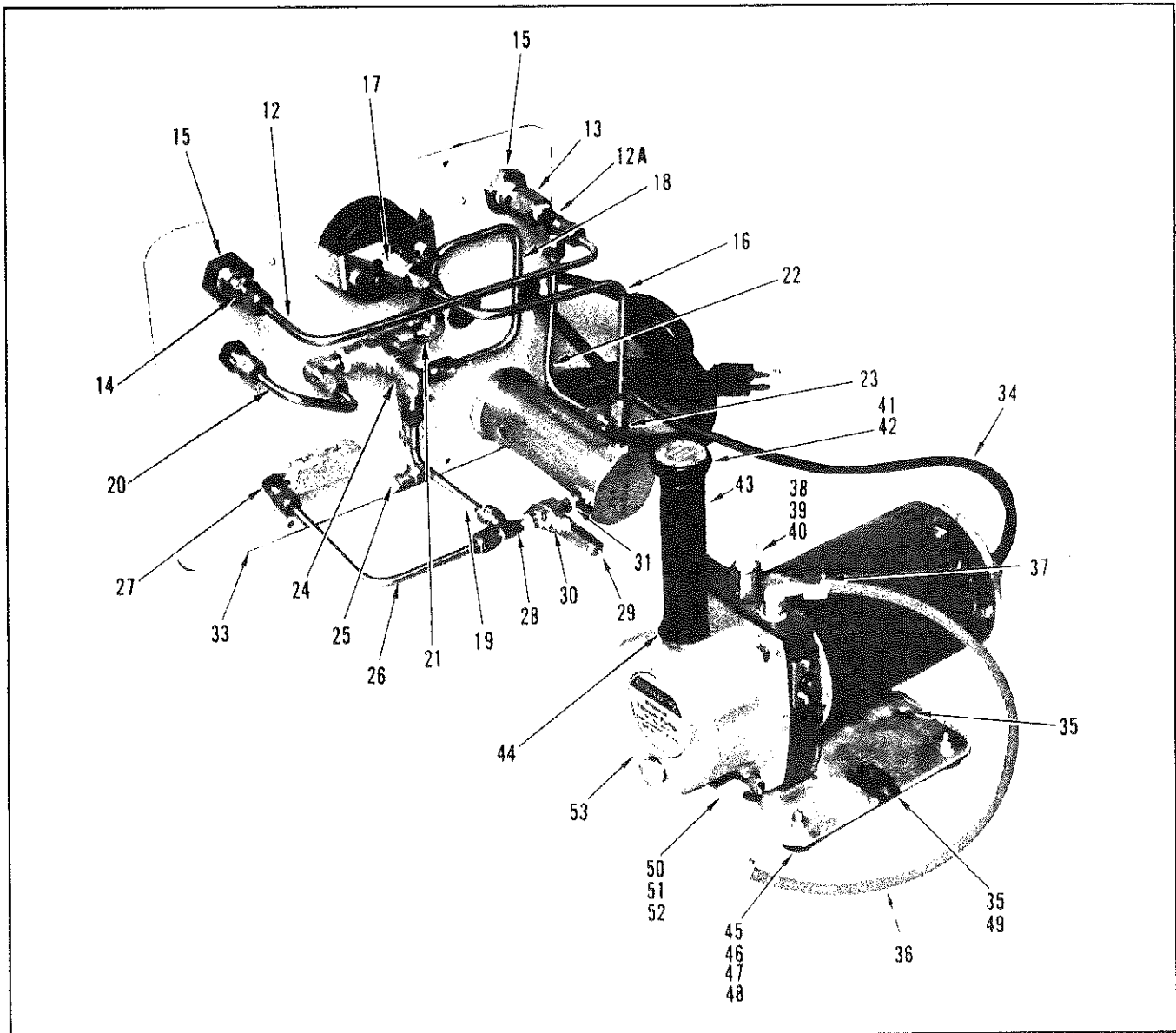

Figure 7-2. Vacuum Pump Case Assembly, Part No. 3657-51-1
(Sheet 2 of 2)

FIGURE AND INDEX NUMBER	PART NUMBER	DESCRIPTION	NOTES
7-2-5	3460-7-1	SOCKET ASSY, HIGH-PRESSURE QUICK-DISCONNECT SEE FIGURE 7-4 FOR DETAILS	2 REQ
-6	3657-46-17	GAUGE, COMPOUND, 0-30 IN. HG; 0-15 PSI RANGE	
-7	3657-46-19	VALVE, THREE-WAY SHUTOFF	
-8	3657-20-1	BAUMANOMETER	
-9	3657-46-15	TUBE ASSY	
-10	3112-27-1	VALVE, METERING SEE FIGURE 7-5 FOR DETAILS	2 REQ

FIGURE AND INDEX NUMBER	PART NUMBER	DESCRIPTION	NOTES
7-2-11	3534-9-1	VALVE ASSY, VERNIER CONTROL SEE FIGURE 7-6 FOR DETAILS	
-12	3657-46-7	TUBE ASSY	
-12A	AN826-4J	TEE	
-13	234-1	ADAPTER	
-14	244-4	ADAPTER	
-15	AN924-10J	NUT	2 REQ
-16	3657-46-11	TUBE ASSY	
-17	3112-33-13	ADAPTER	
-18	3657-46-13	TUBE ASSY	
-19	3657-46-5	TUBE ASSY	
-20	3657-46-3	TUBE ASSY	
-21	AN822-44J	ELBOW	3 REQ
-22	3657-46-9	TUBE ASSY	
-23	AN826-4J	TEE	
-24	AN822-4J	ELBOW	
-25	3657-46-21	ELBOW	
-26	3657-46-15	TUBE ASSY	
-27	AN822-4J	ELBOW	
-28	AN826-4J	TEE	
-29	3460-150-15	VALVE, RELIEF SEE FIGURE 7-14 FOR DETAILS	
-30	AN917-1J	TEE	
-31	AN911-1J	NIPPLE	
-32	3604-18-15	GROMMET	
-33	3657-32-1	PANEL	
-34	3657-53-1	CORD, INPUT POWER	
	3657-43-1	PUMP ASSY (ATTACHING PARTS)	
-35	AN60-5-10	BOLT	2 REQ
		---*---	
-36	3657-42-1	TUBE ASSY	
-37	3646-9-11	ELBOW	
-38	3657-43-5	VALVE, RELIEF	
-39	3657-41-1	ADAPTER	
-40	3657-50-1	GASKET	
-41	3657-40-3	PLUG	
-42	MS29512-8	PACKING	
-43	3657-40-1	SPOUT	
-44	3657-50-3	GASKET	
-45	3613-9-5	FOOT (ATTACHING PARTS)	4 REQ
-46	AN340C6	NUT	4 REQ
-47	AN515C6-10	SCREW	4 REQ
-48	AN936A6	WASHER ---*---	4 REQ
-49	3646-9-13	NUT, SPEED GRIP	2 REQ
-50	3657-34-1	PLATE, BASE (ATTACHING PARTS)	
-51	AN526-420R8	SCREW	2 REQ
-52	AN936A416	LOCKWASHER ---*---	2 REQ
-53	3657-43-3	PUMP	
-54	3657-47-1	CASE ASSY	

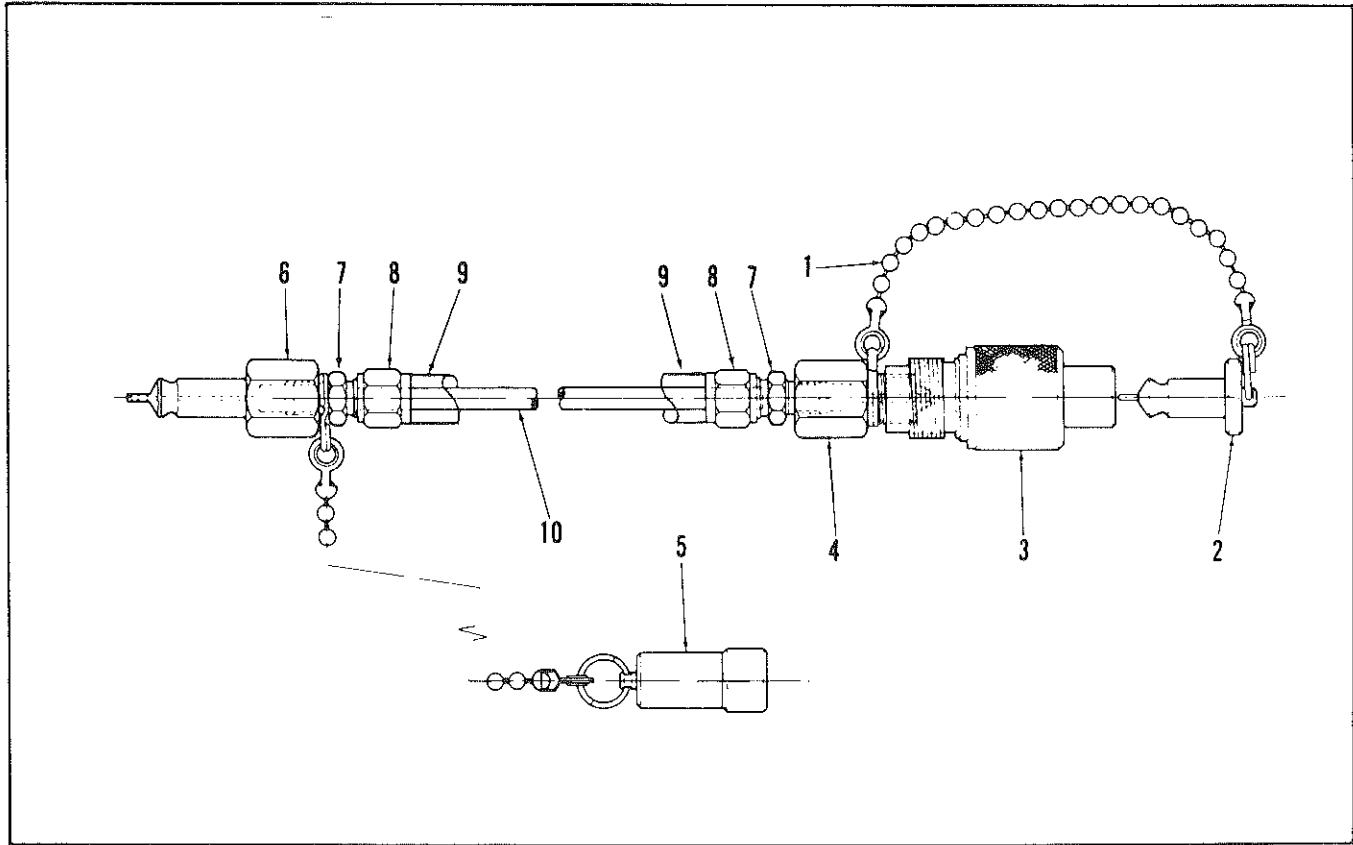

Figure 7-3. Test Hose Assembly, Part No. 3460-104-1200

FIGURE AND INDEX NUMBER	PART NUMBER	DESCRIPTION	NOTES
7-3-	3460-104-1200	HOSE ASSY, TEST	
		SEE FIGURE 7-2 FOR NHA	
	3460-135-5	. PLUG ASSY, DUST	
-1	3460-31-3	. . CHAIN ASSY	
-2	3460-20-3	. . PLUG	
-3	3460-7-1	. SOCKET ASSY, HIGH-PRESSURE QUICK-DISCONNECT	
		SEE FIGURE 7-4 FOR DETAILS	
-4	3460-34-13	. ADAPTER	
-5	3460-49-5	. COVER ASSY, DUST	
-6	3460-30-19	. PROBE	
-7	3460-104-5	. ADAPTER	2 REQ
-8	3514-30-25	. NUT	2 REQ
-9	3514-30-27	. GUARD	2 REQ
-10	3460-104-3-120	. TUBE	

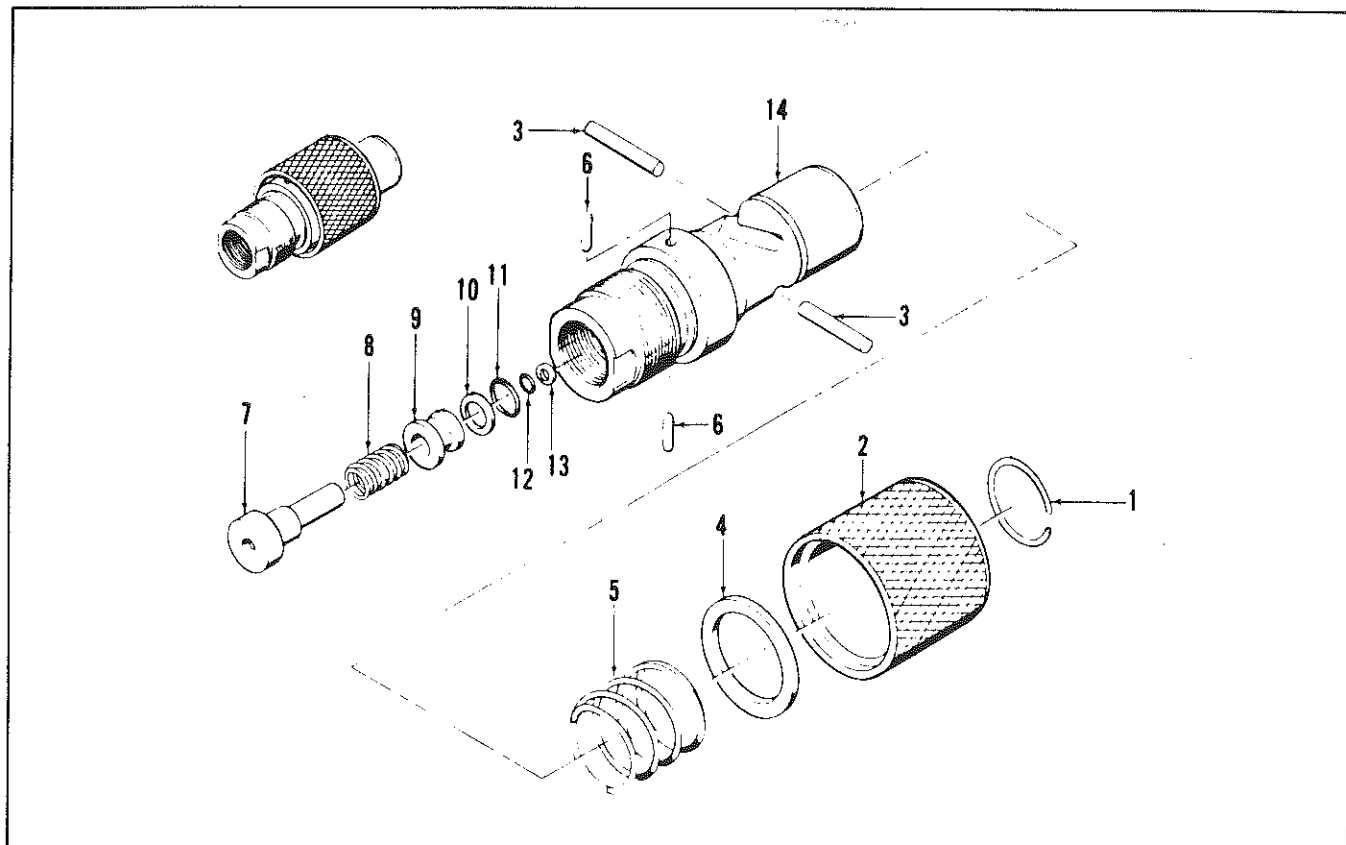

Figure 7-4. High-Pressure Quick-Disconnect Socket Assembly, Part No. 3460-7-1

FIGURE AND INDEX NUMBER	PART NUMBER	DESCRIPTION	NOTES
7-4-	3460-7-1	SOCKET ASSY, HIGH-PRESSURE QUICK-DISCONNECT	
		SEE FIGURES 7-2 AND 7-3 FOR NHA	
-1	3460-8-21	. RING, RETAINING	2 REQ
-2	3460-8-5	. SLEEVE	
-3	3460-8-7	. PIN	2 REQ
-4	3460-8-15	. WASHER	
-5	3460-8-19	. SPRING	
-6	3460-8-9	. PIN	
-7	3460-8-11	. STEM	
-8	3460-8-17	. SPRING	
-9	3460-8-13	. SPOOL	
-10	3460-37-1	. RETAINER, PACKING (NOT CUT)	
-11	*MS28775-008	. PACKING, PREFORMED	
-12	*MS28775-004	. PACKING, PREFORMED	
-13	3460-37-3	. RETAINER, PACKING (NOT CUT)	
-14	3460-8-3	. BODY	

*Parts contained in Packing Kit, Part No. 3657-49-1.

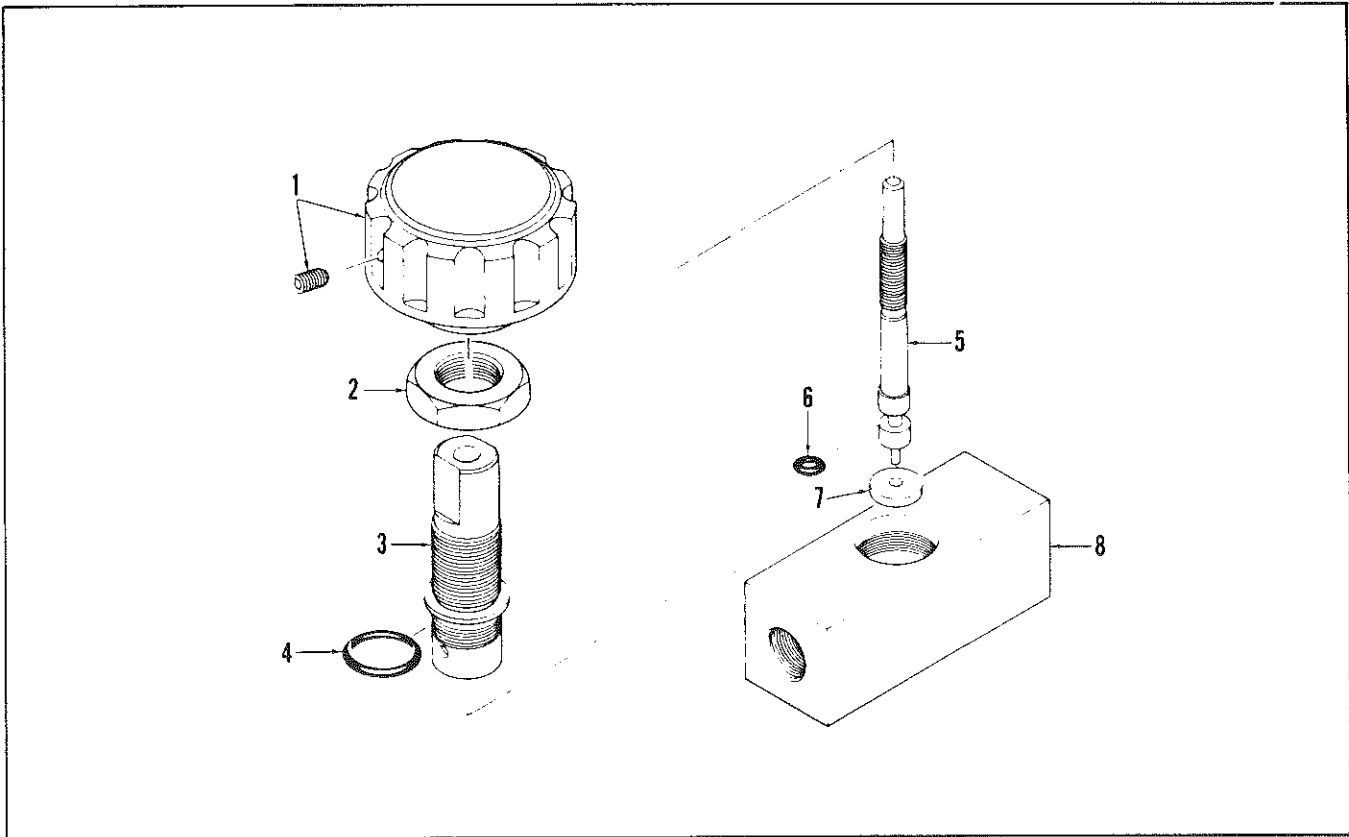

Figure 7-5. Metering Valve Assembly, Part No. 3112-27-1

FIGURE AND INDEX NUMBER	PART NUMBER	DESCRIPTION	NOTES
7-5-	3112-27-1	VALVE ASSY, CONTROL	
		SEE FIGURE 7-2 FOR NHA	
	3112-27-3 BONNET ASSY	
-1	3112-27-13 HANDLE (WITH SETSCREW)	
-2	3112-27-11 NUT, LOCK	
-3	3112-27-9 BONNET	
-4	*MS28775-013 PACKING, PREFORMED	
-5	3112-27-7 STEM	
-6	*MS28775-006 PACKING, PREFORMED	
-7	*3112-27-5 SEAT	
-8	3112-27-15 BODY	

*Parts contained in Packing Kit, Part No. 3657-49-1.

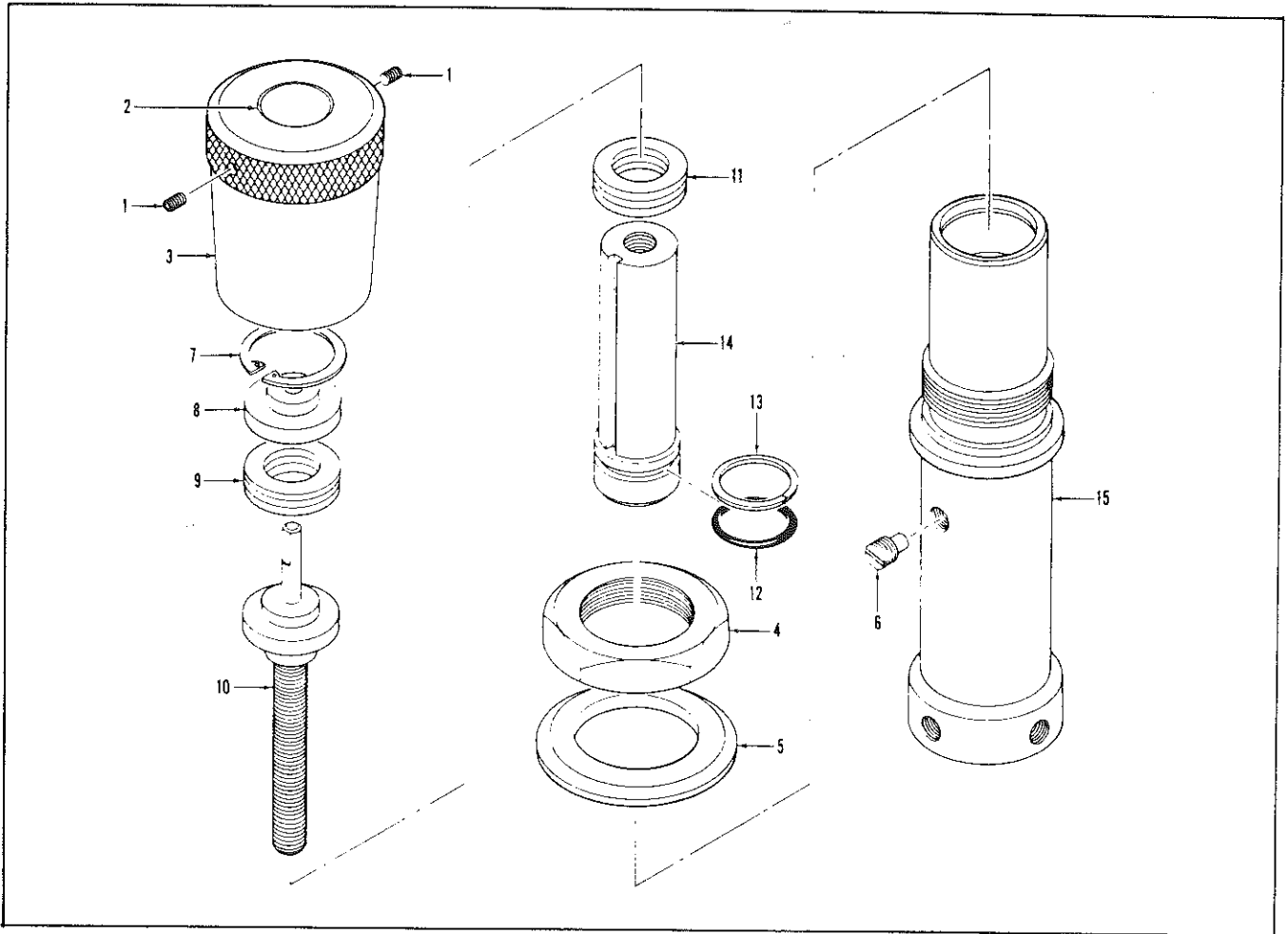

Figure 7-6. Vernier Control Valve Assembly, Part No. 3534-9-1

FIGURE AND INDEX NUMBER	PART NUMBER	DESCRIPTION	NOTES
7-6-	3534-9-1	VALVE ASSY, VERNIER	2 REQ
	3534-8-1	SEE FIGURE 7-2 FOR NHA	
-1	AN565A1-32 KNOB ASSY	
-2	3460-35-11 SETSCREW	
-3	3534-8-3 NAMEPLATE	
-4	3534-8-13 KNOB	
-5	3534-8-15 NUT	
-6	3534-8-17 WASHER	
-7	3534-9-5 KEY ASSY	
-8	3534-8-7 RING, SNAP	
-9	3534-9-3 RETAINER	
-10	3534-8-11 BEARING ASSY, THRUST	
-11	3534-9-3 STEM	
-12	*MS28775-120 BEARING ASSY, THRUST	
-13	*MS28774-120 PACKING, PREFORMED	
-14	3534-8-9 RETAINER, PACKING	
-15	3534-8-5 PISTON	
	 BODY	

*Parts contained in Packing Kit, Part No. 3657-49-1.

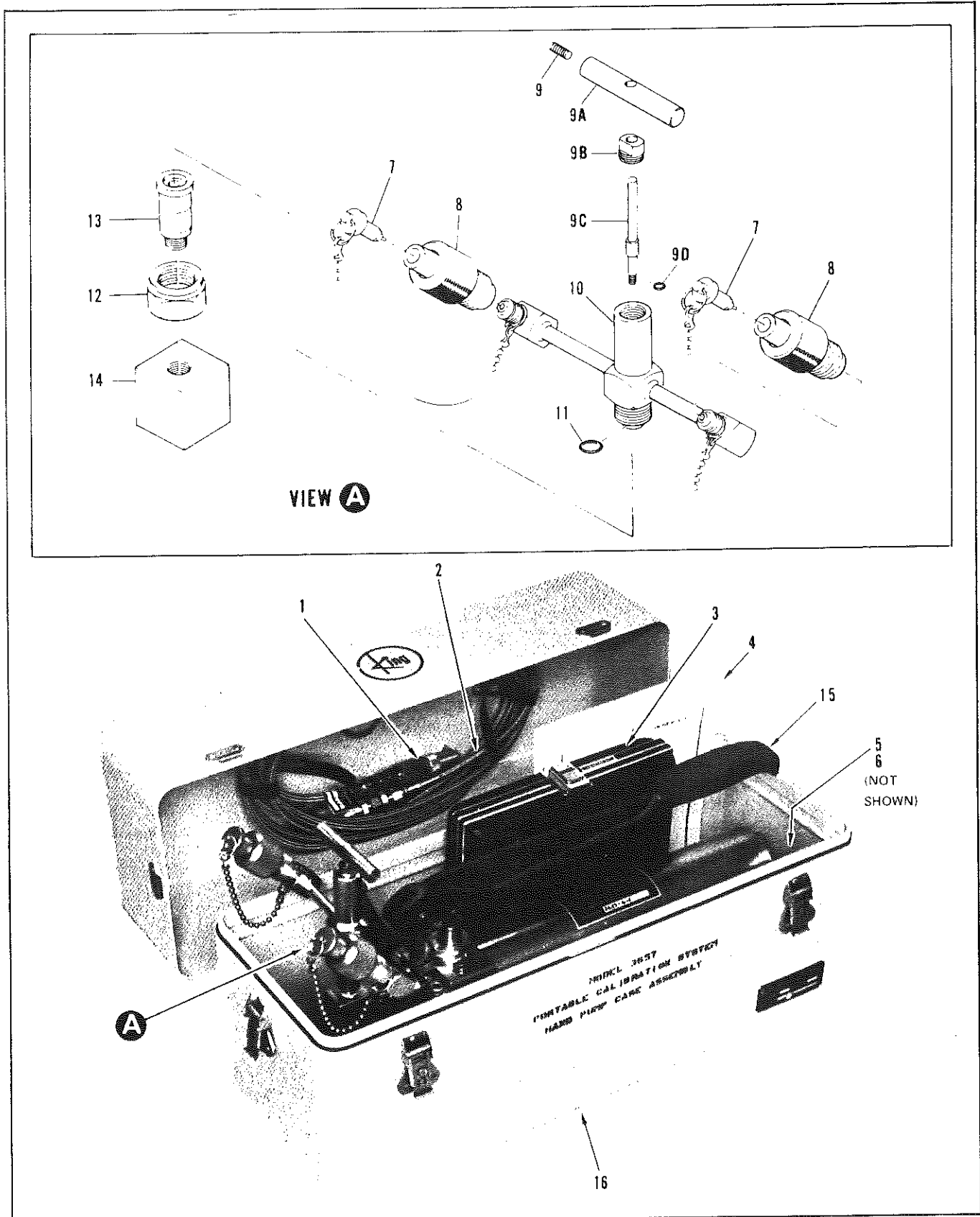

Figure 7-7. Hand Pump Case Assembly, Part No. 3657-45-1

FIGURE AND INDEX NUMBER	PART NUMBER	DESCRIPTION	NOTES
7-7-	3657-45-1	CASE ASSY, HAND PUMP	
		SEE FIGURE 7-1 FOR NHA	
-1	3657-59-0600	. HOSE ASSY, HIGH-PRESSURE, 5-FOOT	
		SEE FIGURE 7-8 FOR DETAILS	
-2	3657-59-1200	. HOSE ASSY, HIGH-PRESSURE, 10-FOOT	
		SEE FIGURE 7-8 FOR DETAILS	
-3	3657-48-1	. KIT, ADAPTER	
		SEE FIGURE 7-9 FOR DETAILS	
-4	3657-56-1	. HANDBOOK, OPERATION AND SERVICE	
		INSTRUCTIONS	
	3657-6-1	. HAND PUMP ASSY	
		(ATTACHING PARTS)	
-5	MS16995-55	. SCREW	4 REQ
-6	AN960C416	. WASHER	4 REQ
		---*---	
	3657-8-1 MANIFOLD ASSY	
-7	3460-135-1 PLUG ASSY, DUST	2 REQ
-8	3460-7-1 SOCKET ASSY, HIGH-PRESSURE	
		QUICK-DISCONNECT	2 REQ
		SEE FIGURE 7-4 FOR DETAILS	
	3514-24-3 STEM ASSY, VALVE	
-9	AN565DC428H8 SETSCREW	
-9A	3514-24-13 HANDLE	
-9B	3460-55-7 RETAINER	
-9C	3514-24-11 STEM	
-9D	MS28775-004 PACKING	
		(TEFLON)	
-10	3657-8-3 BODY, MANIFOLD	
-11	MS28775-012 PACKING	
-12	804-19-11 NUT, UNION	
-13	804-19-9 NIPPLE	
-14	804-19-7 ADAPTER	
-15	804-1-1 HAND PUMP	
		SEE FIGURE 7-10 FOR DETAILS	
-16	3657-33-1	. CASE ASSY	

FIGURE AND INDEX NUMBER	PART NUMBER	DESCRIPTION	NOTES
7-8-	3657-59-0600	HOSE ASSY, HIGH-PRESSURE, 5 FEET	A
		SEE FIGURE 7-7 FOR NHA	
	3657-59-1200	HOSE ASSY, HIGH-PRESSURE, 10 FEET	B
		SEE FIGURE 7-7 FOR NHA	
	3460-135-3	. DUST PLUG ASSY	
-1	3460-31-1 CHAIN ASSY	
-2	3460-20-3 PLUG	
-3	3460-7-1	. SOCKET ASSY, HIGH-PRESSURE QUICK-	
		DISCONNECT	
		SEE FIGURE 7-4 FOR DETAILS	

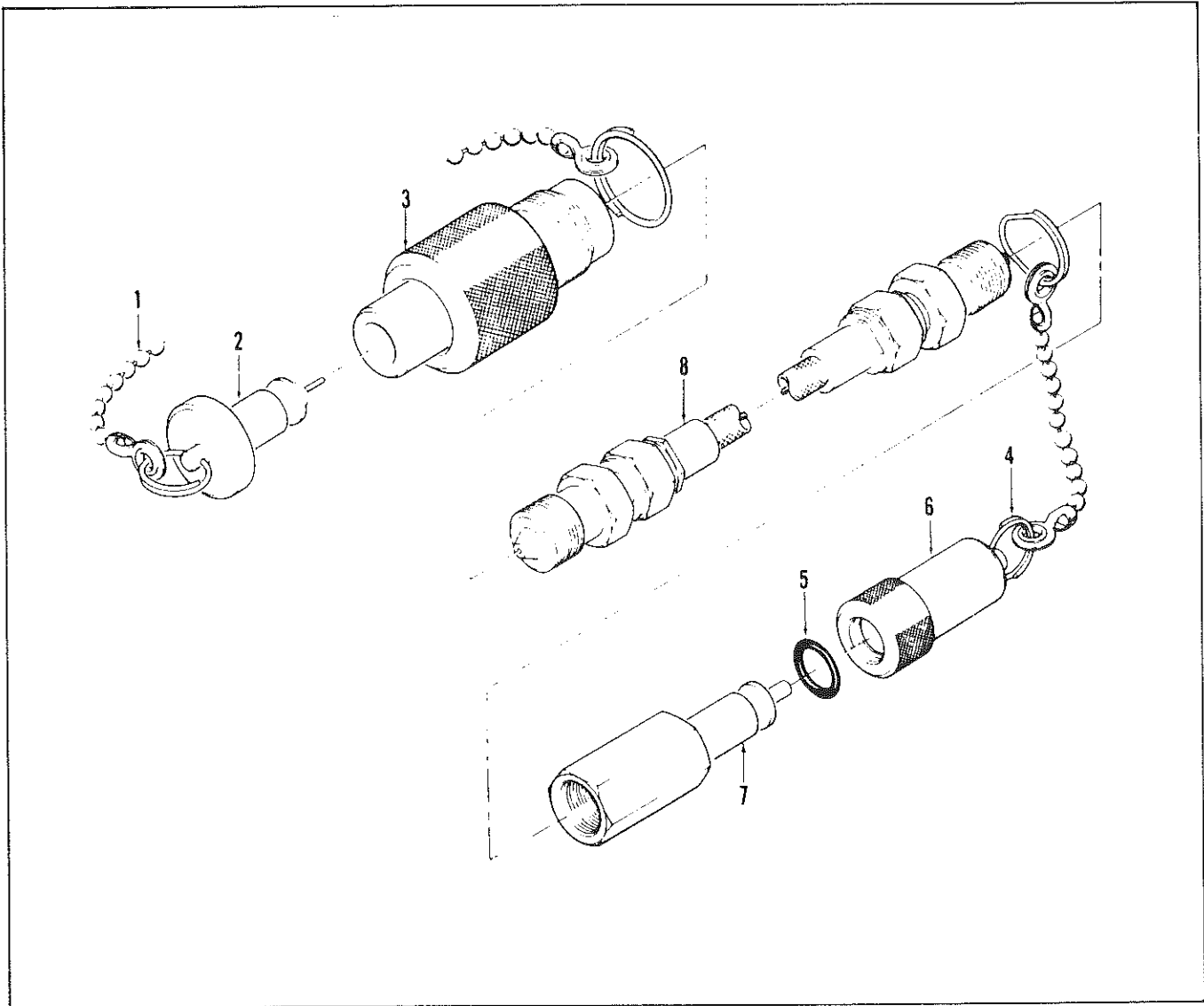

Figure 7-8. High-Pressure Hose Assembly, Part No. 3657-59-0600 and 3657-59-1200

FIGURE AND INDEX NUMBER	PART NUMBER	DESCRIPTION	NOTES
7-8-	3460-49-1	. COVER ASSY, DUST	
-4	3460-31-1	. . CHAIN ASSY	
-5	MS28775-013	. . PACKING, PREFORMED	
-6	3460-49-3	. . BODY	
-7	3460-30-3	. PROBE	
-8	3460-19-0600	. HOSE ASSY, 5 FEET	A
	3460-19-1200	. HOSE ASSY, 10 FEET	B

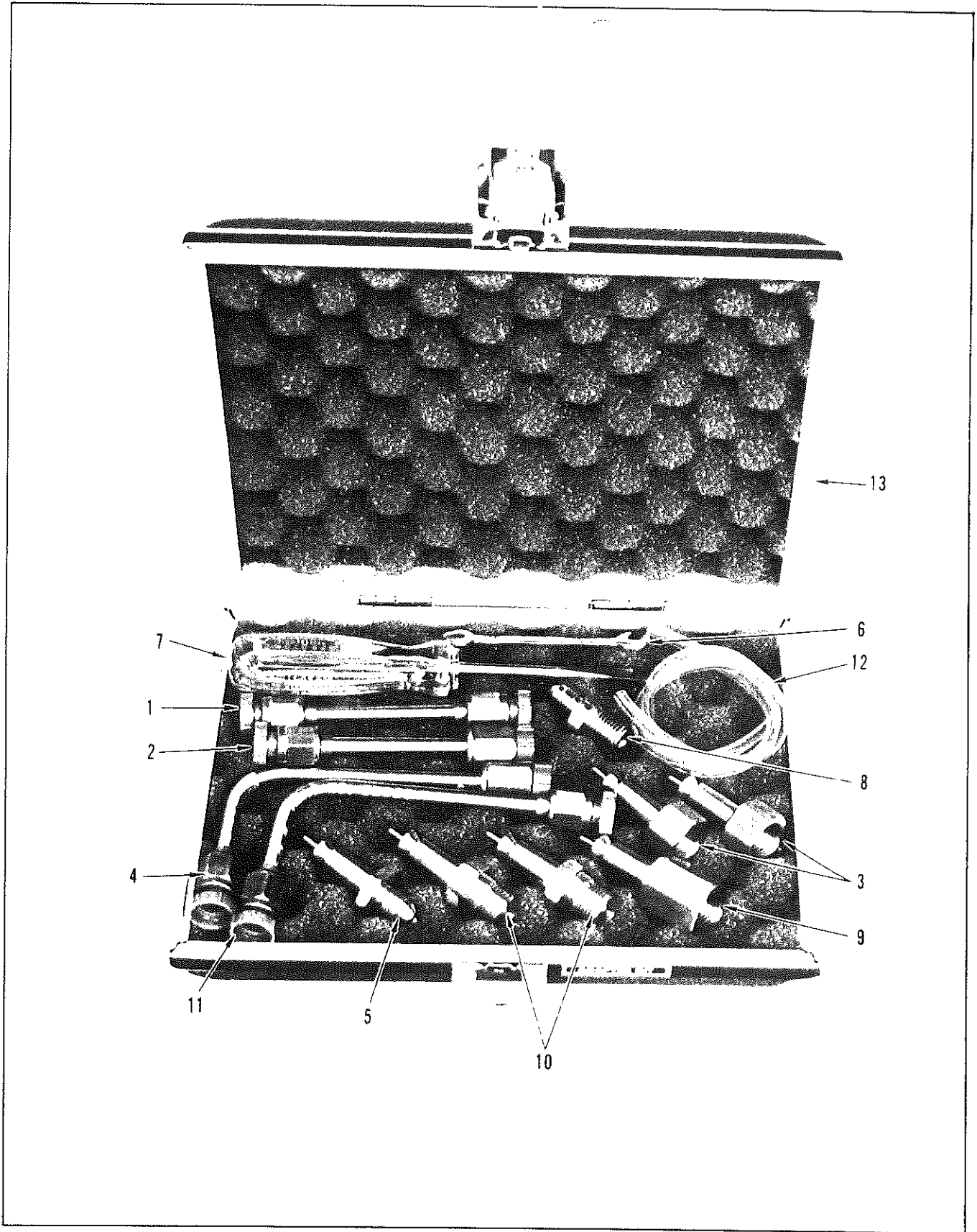

Figure 7-9. Adapter Kit, Part No. 3657-48-1

FIGURE AND INDEX NUMBER	PART NUMBER	DESCRIPTION	NOTES
7-9-	3657-48-1	KIT, ADAPTER	2 REQ
		SEE FIGURE 7-7 FOR NHA	
-1	3657-39-1	. TUBE ASSY	
-2	3657-39-3	. TUBE ASSY	
-3	3460-30-25	. PROBE	
-4	3657-39-7	. TUBE ASSY	
-5	3460-30-5	. PROBE, AND 10056-4 FITTING	
-6	3657-48-3	. WRENCH	
-7	3657-48-5	. SCREWDRIVER	
-8	AN816-4-4J	. ADAPTER	
-9	3460-30-19	. PROBE, FEMALE, 1/4-18NPT	
-10	3460-30-11	. PROBE, MALE, 1/4-18	
-11	3657-39-5	. TUBE ASSY	
-12	3657-48-7	. TUBE, BLEEDER	
-13	3460-174-1	. CASE, ADAPTER KIT	

FIGURE AND INDEX NUMBER	PART NUMBER	DESCRIPTION	NOTES
7-10-	804-1-1	HAND PUMP	2 REQ
		SEE FIGURE 7-7 FOR NHA	
	804-1-3	. HAND PUMP	
-1	804-16-17	. . PLUG, FILL AND VENT	
-2	*MS29512-4	. . PACKING	
-3	804-1-5	. . RING, RETAINING	
-4	804-16-11	. . PIN, UPPER	
-5	804-16-1	. . PIN, LOWER	
-6	804-16-3	. . LINK	
	804-13-1	. HANDLE ASSY	
-7	MS9048-104	. . . PIN, SPRING	
-8	804-13-3	. . . HANDLE	
-9	804-18-1	. . PINION	
	804-1-17	. . PISTON ASSY	
-10	804-18-11	. . . CLOSURE	
-11	804-18-13	. . . SEAT	
-12	*MS28775-008	. . . PACKING	
-13	*804-1-18	. . . RETAINER	
-14	804-21-3	. . . SPRING, RANGE	
-15	804-1-9	. . . BALL	
-16	804-18-15	. . . PISTON	
-17	*MS28775-012	. . . PACKING	
-18	*804-1-11	. . . RETAINER	
-19	804-18-9	. . GLAND	
-20	804-18-7	. . SLEEVE	
-21	*804-18-17	. . WIPER	
-22	*MS28775-017	. . . PACKING	
-23	*804-1-15	. . . RETAINER	
-24	804-18-5	. . INSERT, SLIDE	
-25	*MS28775-013	. . . PACKING	

*Parts contained in Packing Kit, Part No. 3657-49-1

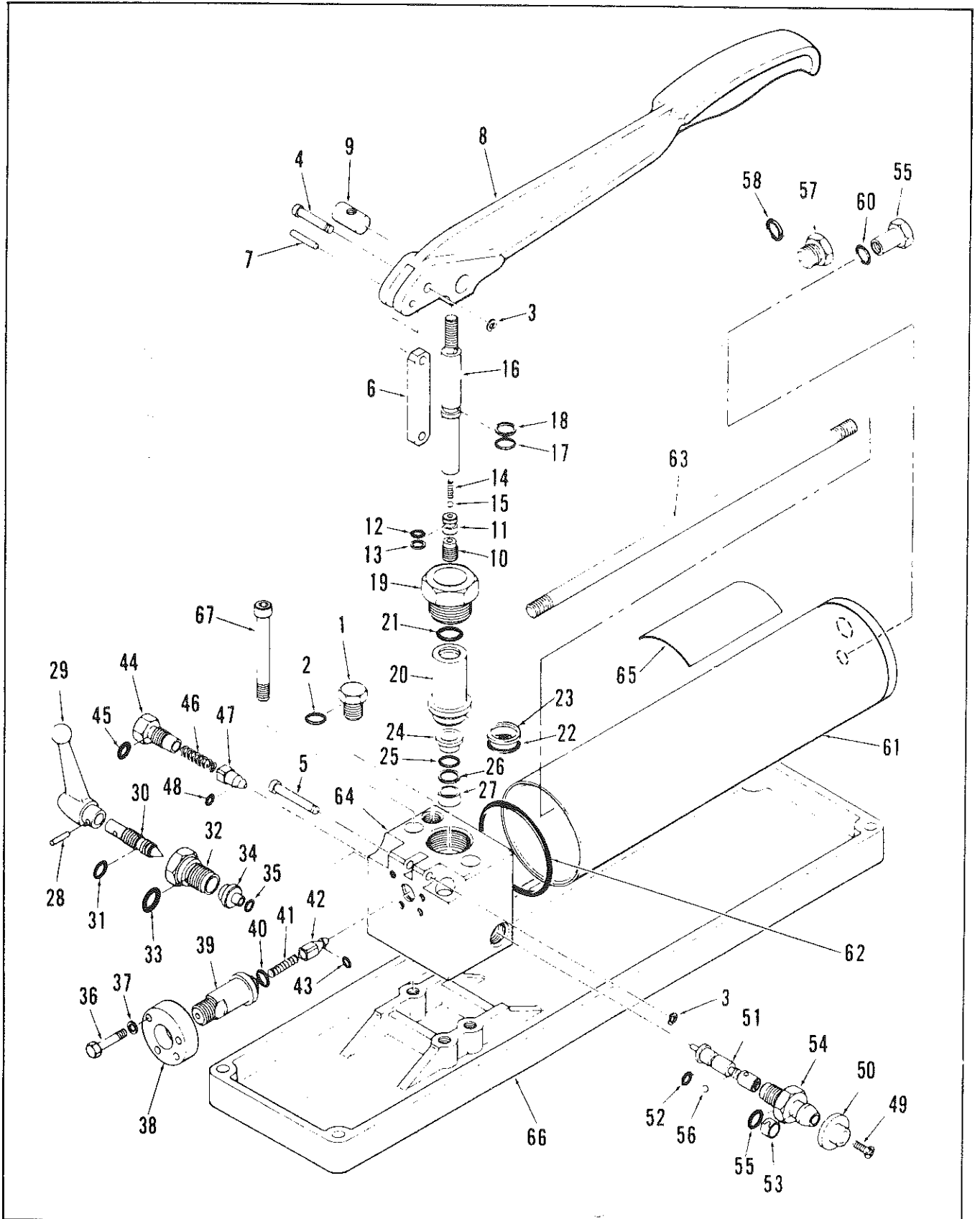

Figure 7-10. Hand Pump, Part No. 804-1-1

FIGURE AND INDEX NUMBER	PART NUMBER	DESCRIPTION	NOTES
7-10-26	*804-1-13	RETAINER	
-27	804-18-3	BUSHING	
-28	MS17152G	PIN, SPRING	
-29	804-20-1	LEVER ASSY	
-30	804-19-3	STEM, VALVE	
-31	*MS28775-011	PACKING	
-32	804-19-1	HOUSING	
-33	*MS28775-113	PACKING	
-34	804-19-5	SEAT	
-35	*MS28775-008	PACKING	
-36	NAS501-4-7A	BOLT	4 REQ
-37	AN960-416	WASHER	4 REQ
-38	804-17-3	FLANGE	
-39	804-17-7	NIPPLE	
-40	*MS28775-012	PACKING	
-41	804-21-1	SPRING, CHECK VALVE	
-42	804-17-5	VALVE, HIGH-PRESSURE CHECK	
-43	*MS28775-006	PACKING	
-44	804-15-9	PLUG	
-45	*MS29512-4	PACKING	
-46	804-21-1	SPRING	
-47	804-15-7	VALVE, LOW-PRESSURE CHECK	
-48	*MS28775-006	PACKING	
-49	AN507C10R6	SCREW	
-50	804-15-5	BUTTON	
-51	804-15-3	PLUNGER	
-52	*MS28775-009	PACKING	
-53	804-15-11	RING, COMPRESSION	
-54	804-15-1	GUIDE	
-55	*MS29512-6	PACKING	
-56	804-1-7	BALL	
-57	804-16-13	PLUG	
-58	*MS28775-014	PACKING	
-59	804-16-5	NUT, RETAINER	
-60	*MS28775-013	PACKING	
-61	804-14-1	SHELL	
-62	*MS28775-148	PACKING	
-63	804-16-9	ROD, TIE	
-64	804-11-1	BODY	
-65	804-23-1	NAMEPLATE	
-66	804-12-1	PAN, DRIP	
-67	COML	SCREW, CAP, STAINLESS STEEL, 5/16-18 THD BY 3-IN. LONG ---*---	3 REQ

*Parts contained in Packing Kit, Part No. 3657-49-1

FIGURE AND INDEX NUMBER	PART NUMBER	DESCRIPTION	NOTES
7-11-	3657-29-1	CASE ASSY, GAUGE (30, 100, AND 300 PSI RANGE MASTER GAUGES) SEE FIGURE 7-1 FOR NHA	
-1	3460-66-13	CHARGER, LIQUID (HYDRAULIC OIL)	
-2	3657-31-30	GAUGE ASSY, MASTER (0- TO 30-PSI RANGE)	

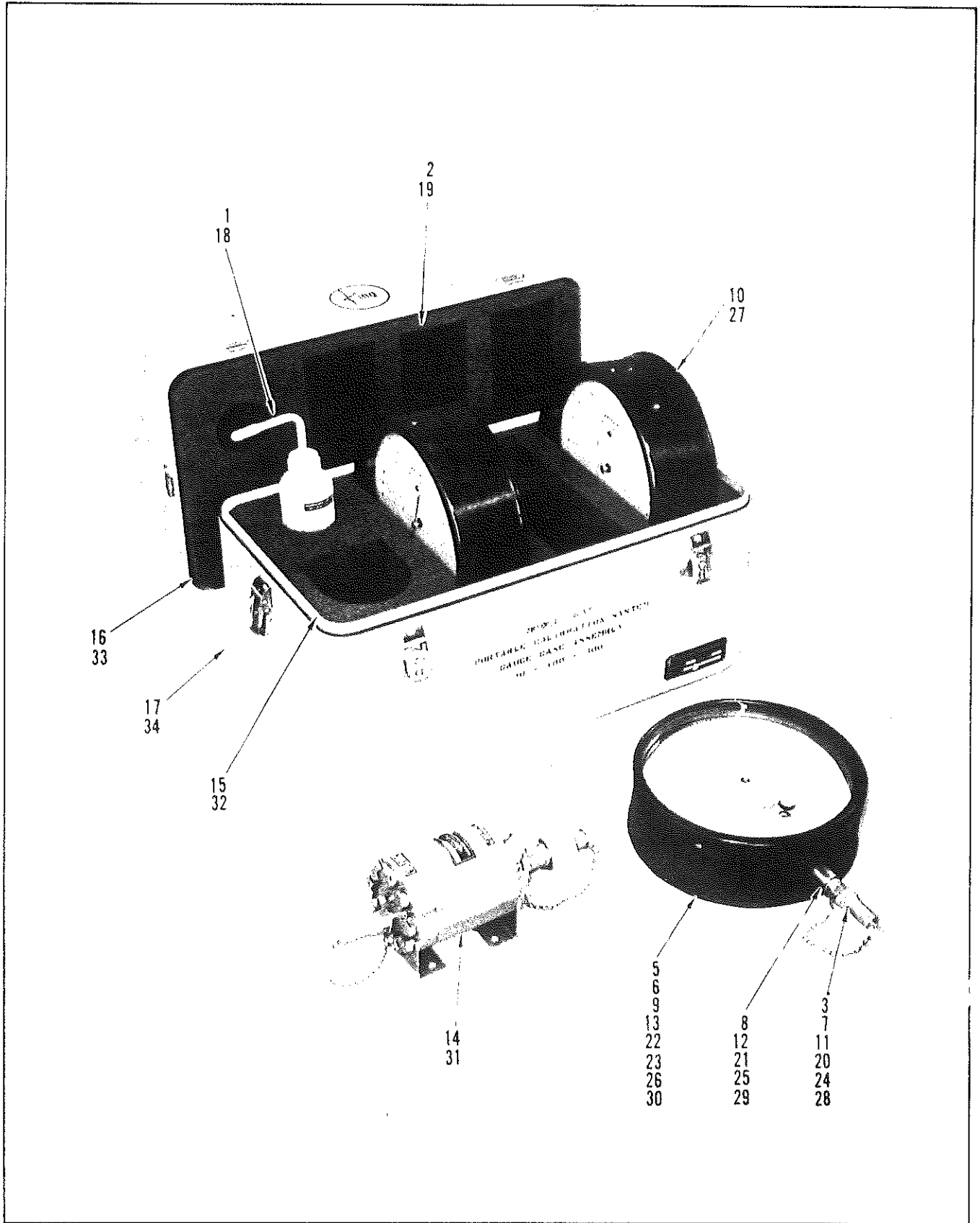

Figure 7-11. Gauge Case Assemblies, Part No. 3657-29-1 and 3657-29-3

FIGURE AND INDEX NUMBER	PART NUMBER	DESCRIPTION	NOTES
7-11-3	3460-49-1	. . COVER, DUST	
	*MS28775-013	. . . PACKING	
-4	3460-30-11	. . PROBE	
-5	3657-38-30	. . GAUGE	
-6	3657-31-100	. GAUGE ASSY, MASTER (0- TO 100-PSI RANGE) . .	
-7	3460-49-1	. . COVER, DUST	
	*MS28775-013	. . . PACKING	
-8	3460-30-11	. . PROBE	
-9	3657-38-100	. . GAUGE	
-10	3657-31-300	. GAUGE ASSY, MASTER (0- TO 300 PSI RANGE) . .	
-11	3460-49-1	. . COVER, DUST	
	*MS28775-013	. . . PACKING	
-12	3460-30-11	. . PROBE	
-13	3657-38-300	. . GAUGE	
-14	3460-54-1	. SEPARATOR ASSY, FLUID (HYDRAULIC OIL) . . . SEE FIGURE 7-12 FOR DETAILS	
	3657-25-1	. LINER SET	
-15	3657-25-3	. . LINER, BOTTOM	
-16	3657-25-5	. . LINER, TOP	
-17	3657-35-1	. CASE ASSY	
	3657-29-3	CASE ASSY, GAUGE (1000, 3000, AND 10,000 PSI RANGE MASTER GAUGES) SEE FIGURE 7-1 FOR NHA	
-18	3460-66-15	. CHARGER, LIQUID (COMPRESSOR OIL)	
-19	3657-31-1000	. GAUGE ASSY, MASTER (0- TO 1000-PSI RANGE) .	
-20	3460-49-1	. . COVER, DUST	
	*MS28775-013	. . . PACKING	
-21	3460-30-11	. . PROBE	
-22	3657-38-1000	. . GAUGE	
-23	3657-31-3000	. GAUGE ASSY, MASTER (0- TO 3000-PSI RANGE) .	
-24	3460-49-1	. . COVER, DUST	
	*MS28775-013	. . . PACKING	
-25	3460-30-11	. . PROBE	
-26	3460-38-3000	. . GAUGE	
-27	3657-31-10,000	. GAUGE ASSY, MASTER (0- TO 10,000-PSI RANGE)	
-28	3460-49-1	. . COVER, DUST	
	*MS28775-013	. . . PACKING	
-29	3460-30-11	. . PROBE	
-30	3657-38-10,000	. . GAUGE	
-31	3460-54-1	. SEPARATOR, FLUID (COMPRESSOR OIL) SEE FIGURE 7-12 FOR DETAILS	
	3657-25-1	. LINER SET	
-32	3657-25-3	. . LINER, BOTTOM	
-33	3657-25-5	. . LINER, TOP	
-34	3657-35-3	. CASE ASSY	

*Parts contained in Packing Kit, Part No. 3657-49-1

FIGURE AND INDEX NUMBER	PART NUMBER	DESCRIPTION	NOTES
7-12-	3460-54-1	SEPARATOR ASSY, FLUID SEE FIGURE 7-11 FOR NHA	
-1	3460-135-1	. PLUG ASSY, DUST	
-2	3460-7-1	. SOCKET ASSY, QUICK-DISCONNECT SEE FIGURE 7-4 FOR DETAILS	
-3	3460-34-21	. ADAPTER	

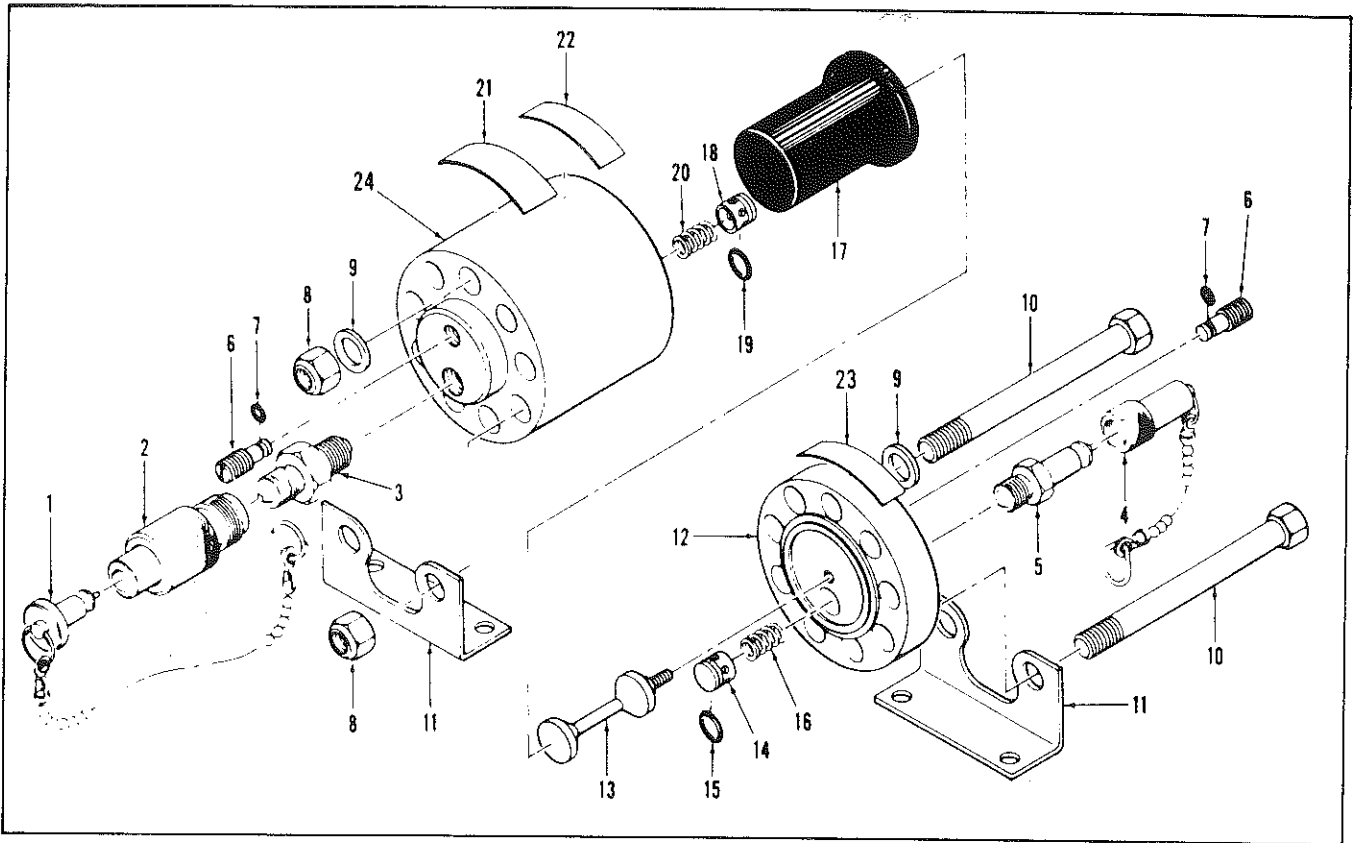

Figure 7-12. Fluid Separator Assembly, Part No. 3460-54-1

FIGURE AND INDEX NUMBER	PART NUMBER	DESCRIPTION	NOTES
7-12-4	3460-49-1	COVER ASSY, DUST	
		SEE FIGURE 7-8 FOR DETAILS	
-5	3460-30-1	PROBE	
	534-2	SEPARATOR ASSY	
-6	3478-3-11	PLUG, FILL	2 REQ
-7	*MS28775-004	PACKING, PREFORMED	2 REQ
-8	MS20365-720	NUT	9 REQ
-9	AN960-716	WASHER	14 REQ
-10	AN7-43A	BOLT	9 REQ
-11	3460-53-1	BRACKET	
-12	534-5	HEAD	
-13	534-7	RETAINER, VALVE	
-14	534-9	VALVE	
-15	*MS28775-012	PACKING, PREFORMED	
-16	534-14	SPRING	
-17	*534-13	DIAPHRAGM	
-18	534-9	VALVE	
-19	*MS28775-012	PACKING, PREFORMED	
-20	534-14	SPRING	
-21	534-11	LABEL	
-22	534-15	PLATE, IDENTIFICATION	
-23	534-17	PLATE, INSTRUCTION	
-24	534-3	BODY	

*Parts contained in Packing Kit, Part No. 3657-49-1

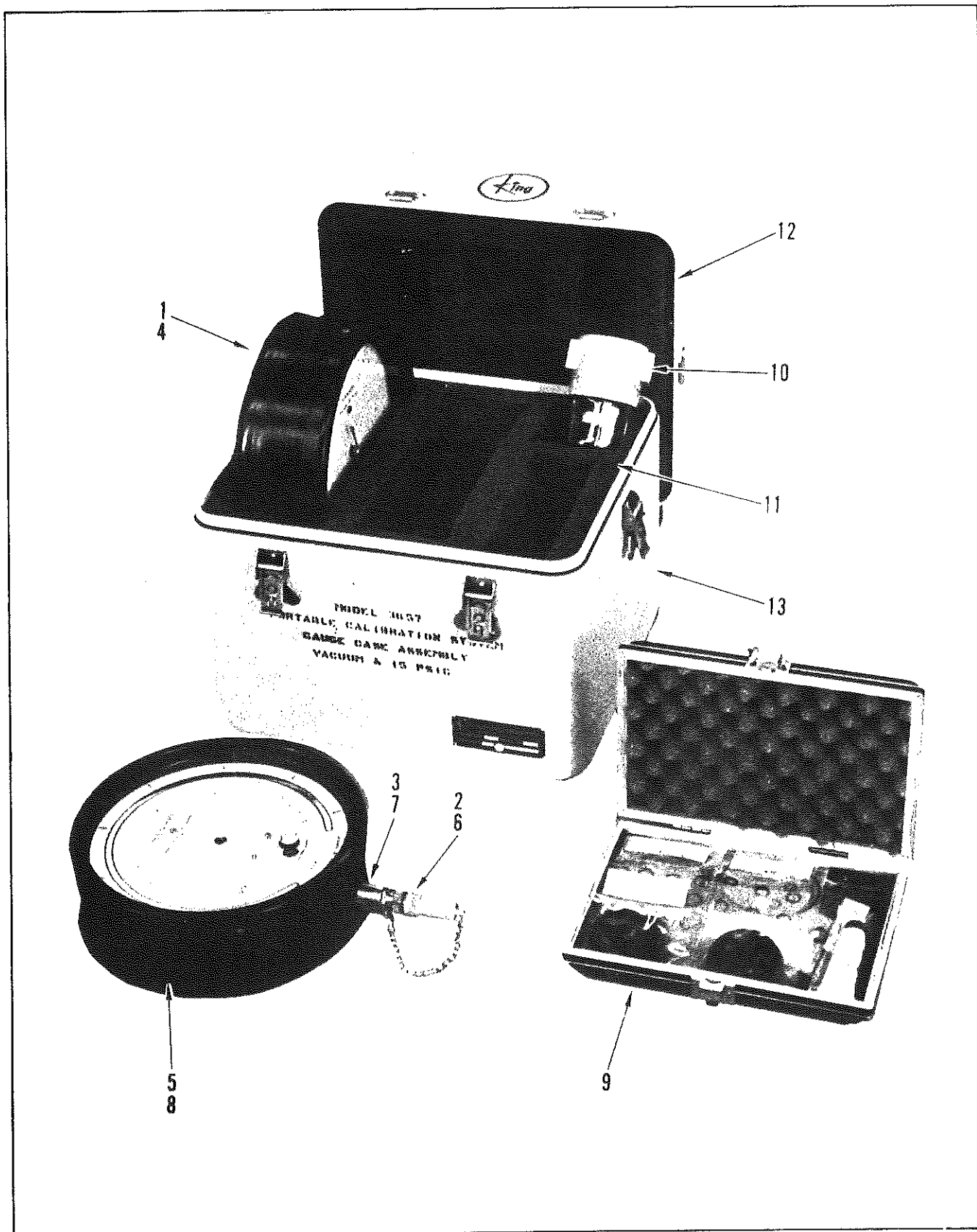

Figure 7-13. Gauge Case Assembly, Part No. 3657-28-1

FIGURE AND INDEX NUMBER	PART NUMBER	DESCRIPTION	NOTES
7-13-	3657-28-1	CASE ASSY, GAUGE (VACUUM AND 15 PSI RANGE MASTER GAUGES)	
		SEE FIGURE 7-1 FOR NHA	
-1	3657-30-15	. GAUGE ASSY, MASTER (0- TO 15 PSI RANGE) . . .	
-2	3460-49-1	. . COVER, DUST	
	*MS28775-013	. . . PACKING	
-3	3460-30-11	. . PROBE	
-4	3657-38-15	. . GAUGE	
-5	3657-30-30Hg	. GAUGE ASSY, MASTER (0- TO 30-IN. HG RANGE)	
-6	3460-49-1	. . COVER, DUST	
	*MS28775-013	. . . PACKING	
-7	3460-30-11	. . PROBE	
-8	3657-38-30Hg	. . GAUGE	
-9	3657-49-1	. KIT ASSY, PACKING	
	3657-49-9	. . KIT, SEAL (12 MS28775-003 PACKINGS)	
	3657-49-11	. . KIT, SEAL (24 MS28775-004 PACKINGS)	
	3657-49-13	. . KIT, SEAL (6 MS28775-004 PACKINGS)	
	3657-49-15	. . KIT, SEAL (6 MS28775-006 PACKINGS)	
	3657-49-17	. . KIT, SEAL (6 MS28775-007 PACKINGS)	
	3657-49-19	. . KIT, SEAL (12 MS28775-008 PACKINGS)	
	3657-49-21	. . KIT, SEAL (6 MS28775-009 PACKINGS)	
	3657-49-23	. . KIT, SEAL (6 MS28775-011 PACKINGS)	
	3657-49-25	. . KIT, SEAL (12 MS28775-012 PACKINGS)	
	3657-49-27	. . KIT, SEAL (24 MS28775-013 PACKINGS)	
	3657-49-29	. . KIT, SEAL (6 MS28775-014 PACKINGS)	
	3657-49-31	. . KIT, SEAL (6 MS28775-017 PACKINGS)	
	3657-49-33	. . KIT, SEAL (6 MS28775-113 PACKINGS)	
	3657-49-35	. . KIT, SEAL (6 MS28775-120 RETAINERS)	
	3657-49-37	. . KIT, SEAL (6 MS28775-120 PACKINGS)	
	3657-49-39	. . KIT, SEAL (6 MS28775-148 PACKINGS)	
	3657-49-41	. . KIT, SEAL (6 MS29512-4 PACKINGS)	
	3657-49-43	. . KIT, SEAL (6 MS29512-6 PACKINGS)	
	3657-49-45	. . KIT, SEAL (6 MS29512-8 PACKINGS)	
	3657-49-47	. . KIT, SEAL (6 534-13 DIAPHRAGMS)	
	3657-49-49	. . KIT, SEAL (6 804-1-11 PACKINGS)	
	3657-49-51	. . KIT, SEAL (6 804-1-13 RETAINERS)	
	3657-49-53	. . KIT, SEAL (6 804-1-15 RETAINERS)	
	3657-49-55	. . KIT, SEAL (6 804-1-18 RETAINERS)	
	3657-49-57	. . KIT, SEAL (6 804-18-17 WIPERS)	
	3657-49-59	. . KIT, SEAL (6 3460-37-1 RETAINERS)	
	3657-49-61	. . KIT, SEAL (6 3460-37-3 RETAINERS)	
	3657-49-63	. . KIT, SEAL (6 3112-27-5 SEATS)	
	3460-80-1	. . LUBRICANT	
	3460-174-1	. . BOX	
-10	3657-28-3	. . FILTER	
	3657-26-1	. . LINER SET	
-11	3657-26-3	. . LINER, BOTTOM	
-12	3657-26-5	. . LINER, TOP	
-13	3657-36-1	. . CASE ASSY	

*Parts contained in Packing Kit, Part No. 3657-49-1.

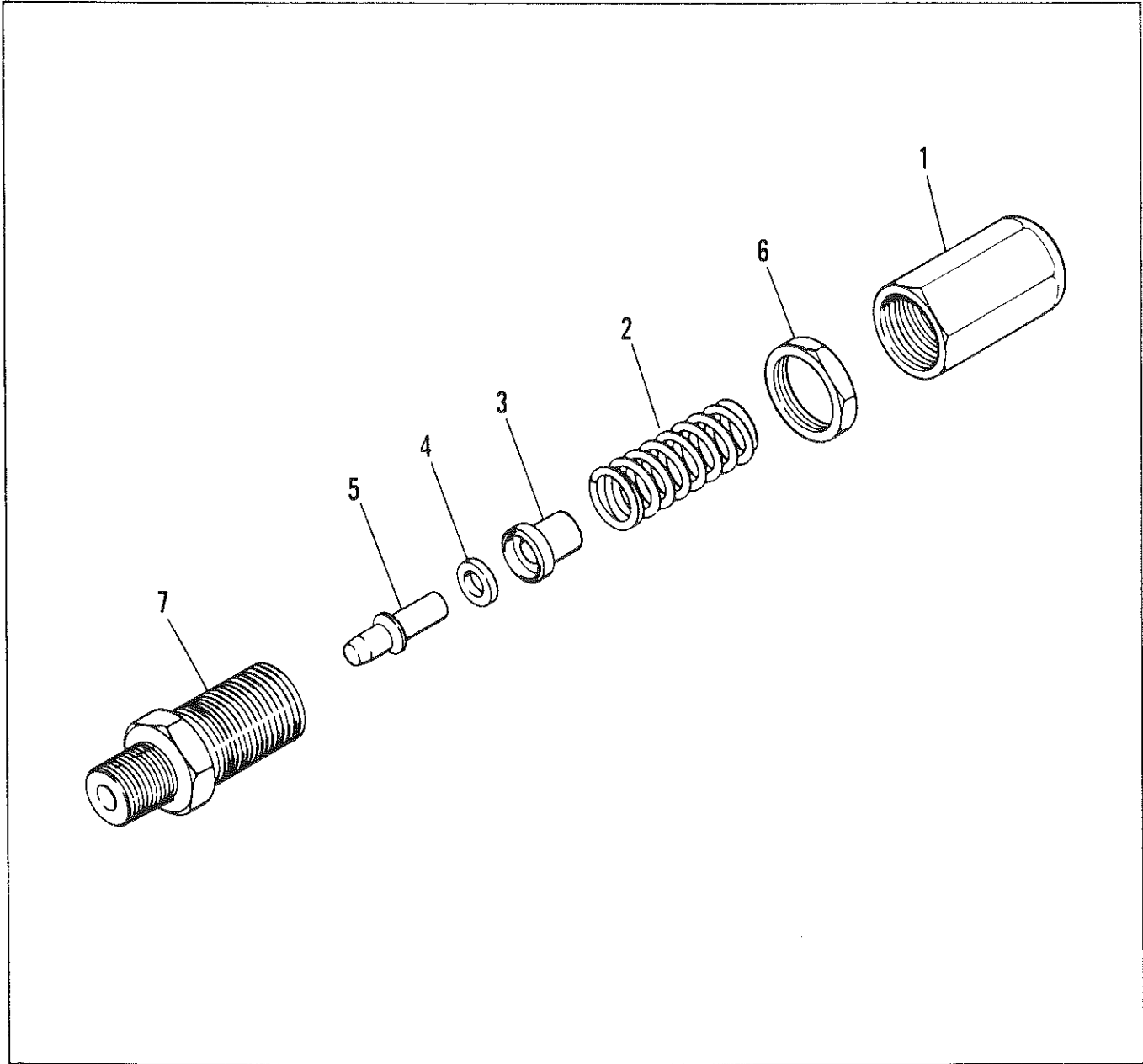

Figure 7-14. Relief Valve, Part No. 3460-150-15

FIGURE AND INDEX NUMBER	PART NUMBER	DESCRIPTION	NOTES
7-14-	3460-150-15	VALVE, RELIEF	
		SEE FIGURE 7-2 FOR NHA	
-1	3460-150-11	. CAP	
-2	3460-172-15	. SPRING	
-3	3460-150-3	. GUIDE	
-4	3460-150-19	. SEAL	
-5	3460-150-5	. POPPET	
-6	3460-150-13	. CHECK NUT	
-7	3460-150-9	. BODY	

CHAPTER 8

INSTALLATION

8-1. INTRODUCTION

8-2. The portable calibration system is a portable system with components housed in five case assemblies for storage and transportation.

8-3. SITE INFORMATION

8-4. No permanent site is required. Space for storage is required. During operation of the vacuum pump, 115 V ac, 60 Hz 4 amperes from a standard 3-wire grounded outlet is required. Refer to figures 8-2 through 8-4 for overall dimensions.

8-5. REFERENCE PUBLICATIONS

8-6. Refer to this manual for information relating to the portable calibration system.

8-7. TOOLS AND MATERIALS NEEDED FOR INSTALLATION

8-8. No special tools are required; no materials are required.

8-9. UNPACKING AND REPACKING

8-10. When unpacking the portable calibration system, visually inspect all components for evidence of damage incurred during shipment. Remove any foreign elements (dust, packing material, etc.) from the equipment using a clean, lint-free cloth. When repacking the portable calibration system place all equipment into the proper case assembly. Close and latch each case assembly then wrap and seal each case assembly in barrier material, MIL-B-121, Type I, Grade A, Class I, with two packets of dessicant

material, type MIL-D-3464, Class 1 enclosed. Enclose each case assembly in a container in accordance with good commercial practice with sufficient packing material to prevent damage during shipment.

8-11. Refer to figure 8-1 and use care when unpacking master gauges. Remove master gauge back plate by unscrewing captive screw. Carefully remove packing material taking care not to push on sector gear, linkage, or any movement parts. Carefully remove polyfoam packing, taking care not to shake or shock the movement assembly suddenly. Remove paper stop by deflecting bourdeon assembly slowly upward just enough to allow space to slowly pull paper stop out. Do not push on sector gear, linkage, or any movement parts.

8-12. PREPARATION OF FOUNDATION

8-13. Not applicable to the portable calibration system.

8-14. INPUT REQUIREMENTS

8-15. During operation of the vacuum pump, 115 V ac, 60 Hz, 4 amperes from a standard 3-wire grounded outlet is required. No other inputs are required to operate the portable calibration system.

8-16. INSTALLATION PROCEDURES

8-17. No permanent installation of the portable calibration system is required. Refer to Chapter 2 for temporary installation requirements during operation of the portable calibration system.

8-18. INSTALLATION CHECKOUT

8-19. Not applicable to the portable calibration system.

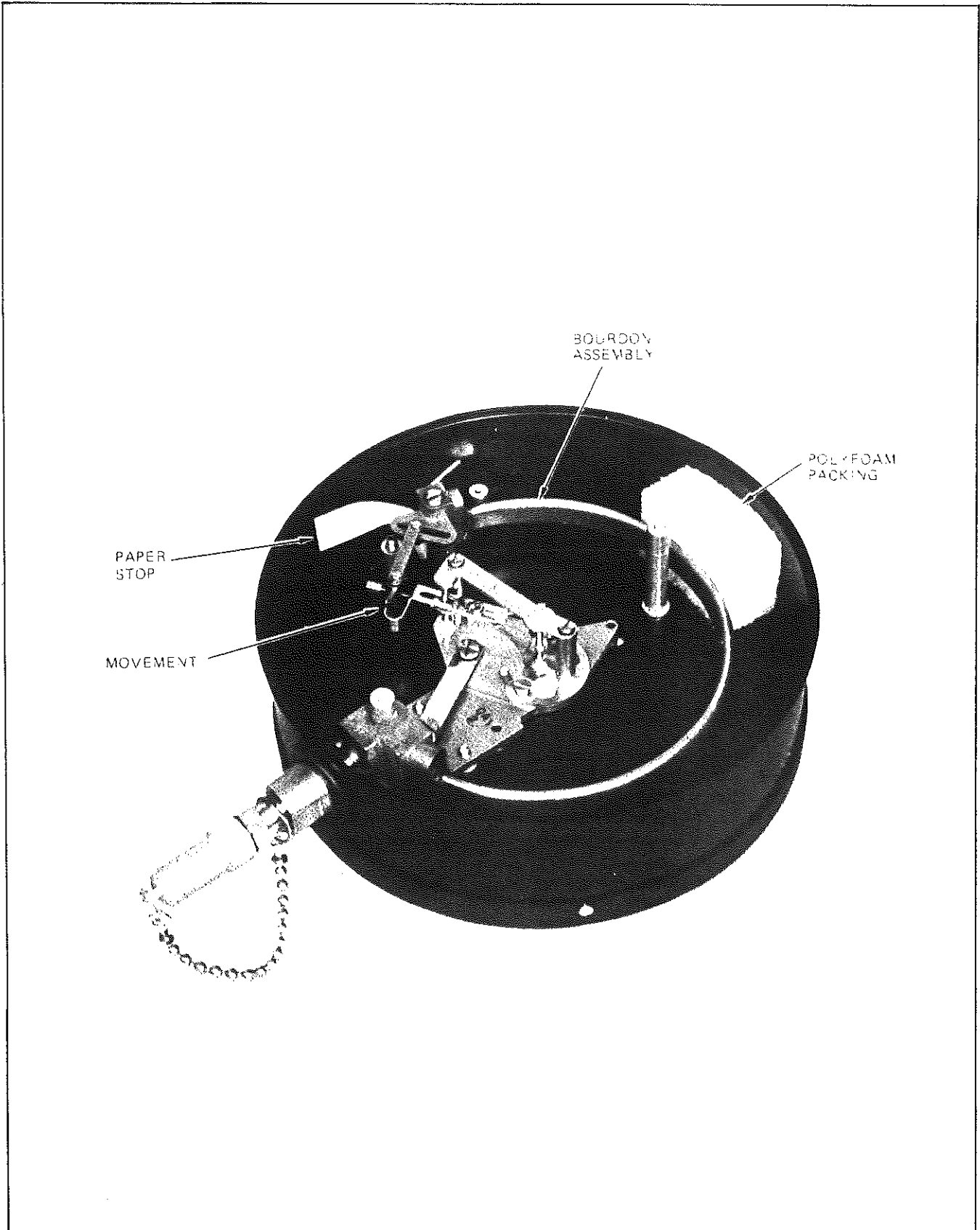
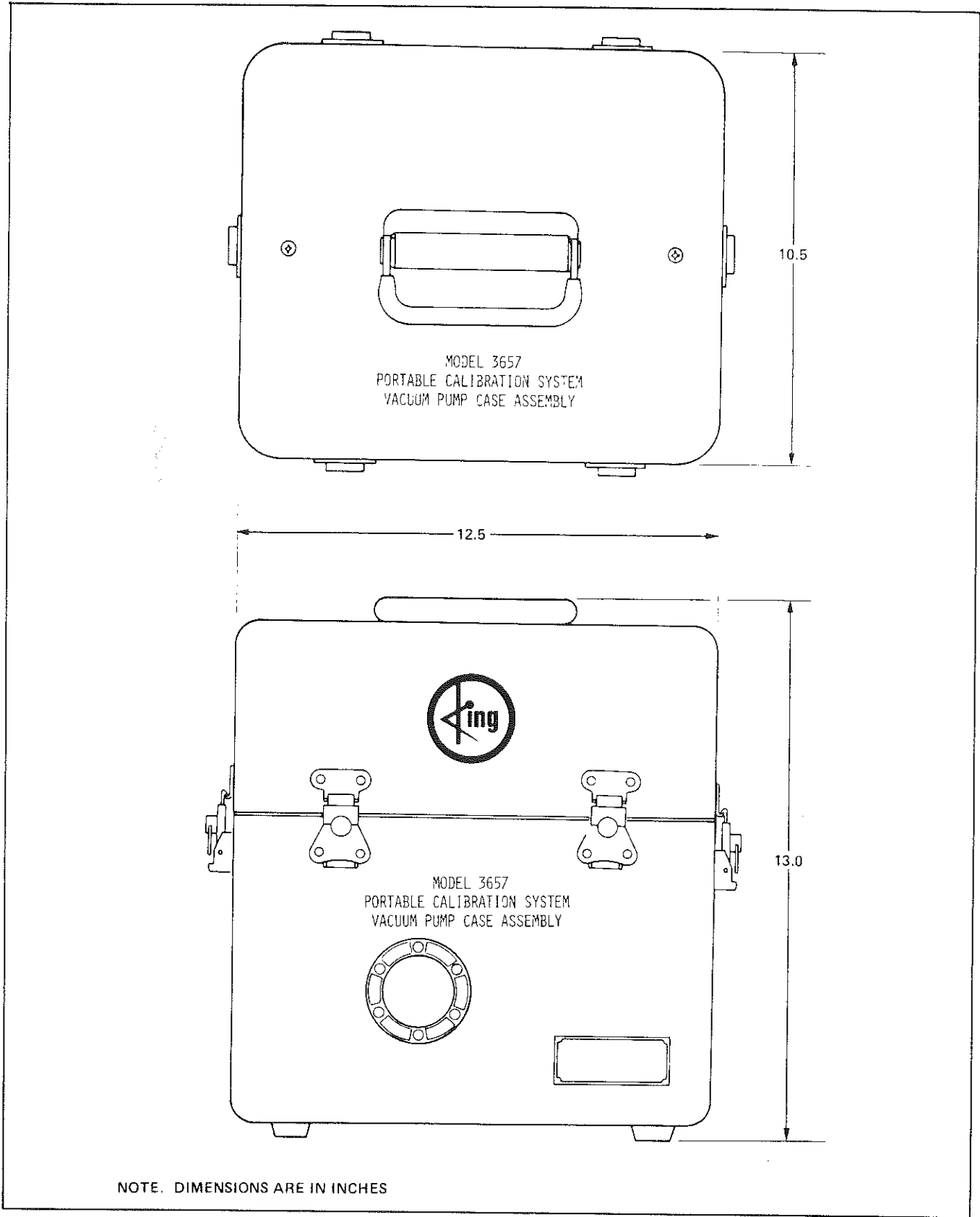

Figure 8-1. Unpacking Master Gauges



NOTE. DIMENSIONS ARE IN INCHES

Figure 8-2. Installation Drawing – Vacuum and 15 Psig Gauge Case and Vacuum Pump Case Assembly

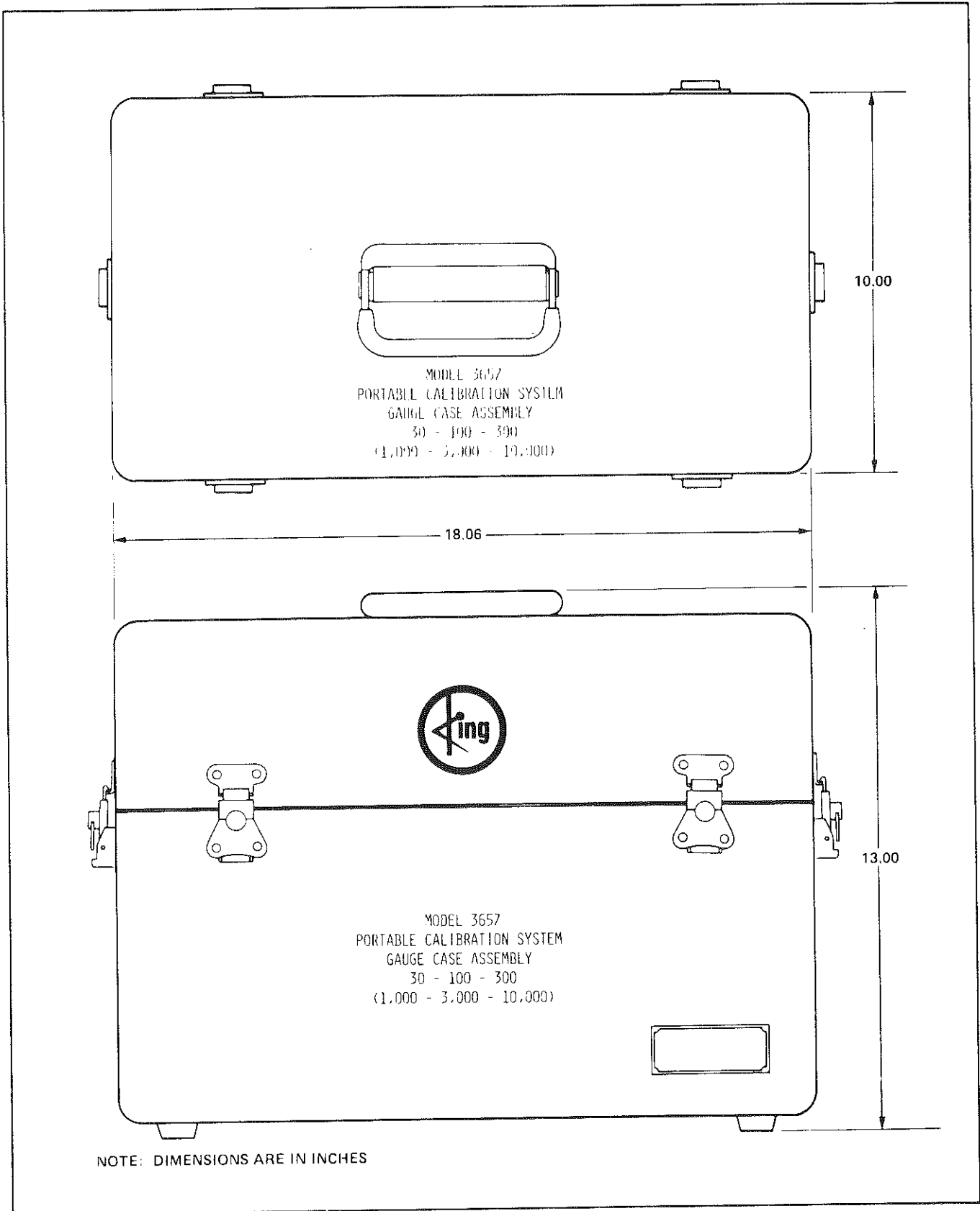

Figure 8-3. Installation Drawing — 30, 100, 300 Psig Gauge Case Assembly and 1000, 3000, 10,000 Psig Gauge Case Assembly

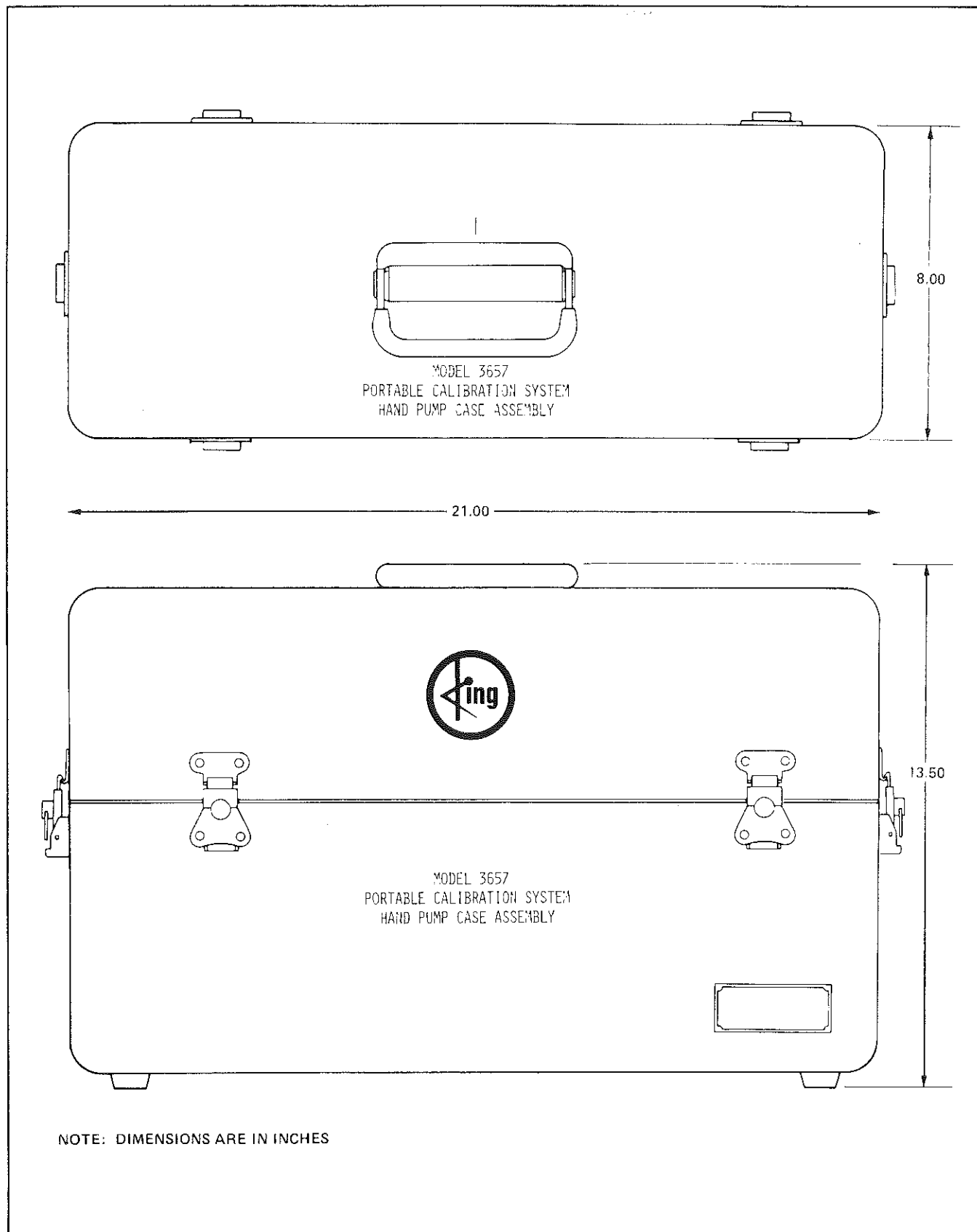

Figure 8-4. Installation Drawing — Hand Pump Case Assembly

FOLD

DEPARTMENT OF THE NAVY

NAVAL SHIP WEAPON SYSTEMS
ENGINEERING STATION
PORT HUENEME, CALIFORNIA 93043

OFFICIAL BUSINESS

PENALTY FOR PRIVATE USE, \$300

11ND-NSWSES-2700/11 (2-79)

POSTAGE AND FEES PAID
DEPARTMENT OF THE NAVY
DoD-316



COMMANDING OFFICER
NAVAL SHIP WEAPON SYSTEMS ENGINEERING STATION
NAVAL SEA DATA SUPPORT ACTIVITY
CODE 5700
PORT HUENEME, CA 93043

FOLD

NAVSEA (USER) TECHNICAL MANUAL DEFICIENCY/EVALUATION REPORT (TMDER)

(Use this report to indicate deficiencies, user remarks and recommendations relating to the publication.
Fold on dotted line, staple, and mail to NAVAL SEA DATA SUPPORT ACTIVITY.)

NAVSEA 5600/2 (6-76) (back) (Formerly NAVSHIPS 5600/2)

REPORT DATE:

1. NAVSEA NO.	2. VOLUME NO.	3. TITLE (NOMENCLATURE)			
4. (TM/CHG, REV. DATE)	MICROFILM/MICROFICHE				
5. CART/FICHE NO.		6. CART/FICHE DATE	7. FRAME NO.	8. OTHER I.D. NO.	
9. SYSTEM/EQUIPMENT		10. IDENTIFICATION (MK/MOD/AN)		11. PRIORITY	

12. USER EVALUATION

MANUAL IS: EXCELLENT GOOD FAIR POOR COMPLETE INCOMPLETE

RELATED REMARKS:

13. PROBLEM QUESTION SUGGESTION COMMENT: (Check One)

14. RECOMMENDED CHANGE TO PUBLICATION

PAGE NO.	PARA-GRAPH	LINE NO.	FIGURE NO.	TABLE NO.	RECOMMENDED CHANGES AND REASON (Use Blank Continuation Sheets as Required)

15. ORIGINATOR	16. RANK/RATE/TITLE
17. WORK CENTER	18. SUPERVISOR
19. SHIP HULL NO. AND/OR STATION ADDRESS	

20. NSDSA USE ONLY

a. CONTROL NO.	b. COG ISEA	DATE			f.	g.	h.	i.	j.	k. NSDSA PRIORITY	l. FINAL PRIORITY
		c. REC.	d. FWD	e. DUE							

FOLD

DEPARTMENT OF THE NAVY

NAVAL SHIP WEAPON SYSTEMS
ENGINEERING STATION
PORT HUENEME, CALIFORNIA 93043

OFFICIAL BUSINESS
PENALTY FOR PRIVATE USE, \$300
11ND-NWSSES-2700/11 (2-75)

POSTAGE AND FEES PAID
DEPARTMENT OF THE NAVY
DoD-316



COMMANDING OFFICER
NAVAL SHIP WEAPON SYSTEMS ENGINEERING STATION
NAVAL SEA DATA SUPPORT ACTIVITY
CODE 5700
PORT HUENEME, CA 93043

FOLD

FOLD

DEPARTMENT OF THE NAVY
NAVAL SHIP WEAPON SYSTEMS
ENGINEERING STATION
PORT HUENEME, CALIFORNIA 93043

OFFICIAL BUSINESS
PENALTY FOR PRIVATE USE, \$300
11ND-NWSES-2700/11 (2-78)

POSTAGE AND FEES PAID
DEPARTMENT OF THE NAVY
D&D-316



COMMANDING OFFICER
NAVAL SHIP WEAPON SYSTEMS ENGINEERING STATION
NAVAL SEA DATA SUPPORT ACTIVITY
CODE 5700
PORT HUENEME, CA 93043

FOLD